

# SECTION **MTC**

## MANUAL AIR CONDITIONER

A  
B  
C  
D  
E  
F  
G  
H  
I  
J  
K  
L  
M

### CONTENTS

<p><b>PRECAUTIONS ..... 4</b></p> <p>    Precautions for Supplemental Restraint System (SRS) "AIR BAG" and "SEAT BELT PRE-TENSIONER" ..... 4</p> <p>    Precautions for Working with HFC-134a (R-134a).... 4</p> <p>    Contaminated Refrigerant ..... 4</p> <p>    General Refrigerant Precautions ..... 5</p> <p>    Precautions for Leak Detection Dye ..... 5</p> <p>    A/C Identification Label ..... 6</p> <p>    Precautions for Refrigerant Connection ..... 6</p> <p>        FEATURES OF NEW TYPE REFRIGERANT CONNECTION ..... 6</p> <p>        O-RING AND REFRIGERANT CONNECTION..... 7</p> <p>    Precautions for Servicing Compressor ..... 9</p> <p>    Precautions for Service Equipment ..... 9</p> <p>        RECOVERY/RECYCLING EQUIPMENT ..... 9</p> <p>        ELECTRONIC LEAK DETECTOR ..... 9</p> <p>        VACUUM PUMP ..... 10</p> <p>        MANIFOLD GAUGE SET ..... 10</p> <p>        SERVICE HOSES ..... 10</p> <p>        SERVICE COUPLERS ..... 11</p> <p>        REFRIGERANT WEIGHT SCALE ..... 11</p> <p>        CHARGING CYLINDER ..... 11</p> <p>    Wiring Diagrams and Trouble Diagnosis ..... 11</p> <p><b>PREPARATION ..... 12</b></p> <p>    Special Service Tools ..... 12</p> <p>    HFC-134a (R-134a) Service Tools and Equipment.. 12</p> <p>    Commercial Service Tools ..... 15</p> <p><b>REFRIGERATION SYSTEM ..... 16</b></p> <p>    Refrigerant Cycle ..... 16</p> <p>        REFRIGERANT FLOW ..... 16</p> <p>    Refrigerant System Protection ..... 16</p> <p>        REFRIGERANT PRESSURE SENSOR ..... 16</p> <p>        PRESSURE RELIEF VALVE ..... 17</p> <p>    Component Layout ..... 18</p> <p>        REFRIGERATION SYSTEM ..... 18</p> <p><b>LUBRICANT ..... 20</b></p> <p>    Maintenance of Lubricant Quantity in Compressor.. 20</p> <p>        LUBRICANT ..... 20</p> <p>        CHECKING AND ADJUSTING ..... 20</p>	<p><b>AIR CONDITIONER CONTROL ..... 22</b></p> <p>    Description ..... 22</p> <p>    Operation ..... 22</p> <p>        AIR MIX DOOR CONTROL ..... 22</p> <p>        BLOWER SPEED CONTROL ..... 22</p> <p>        INTAKE DOORS CONTROL ..... 22</p> <p>        MODE DOOR CONTROL ..... 22</p> <p>        DEFROSTER DOOR CONTROL ..... 22</p> <p>        MAGNET CLUTCH CONTROL ..... 22</p> <p>        SELF-DIAGNOSTIC SYSTEM ..... 23</p> <p>    Description of Control System ..... 24</p> <p>    Control Operation ..... 24</p> <p>        TEMPERATURE CONTROL DIAL (TEMPERATURE CONTROL) ..... 25</p> <p>        RECIRCULATION ( ) SWITCH ..... 25</p> <p>        REAR WINDOW DEFOGGER SWITCH ..... 25</p> <p>        OFF SWITCH (BLOWER SPEED SET TO 0) .... 25</p> <p>        A/C SWITCH ..... 25</p> <p>        MODE CONTROL DIAL ..... 25</p> <p>        FRONT BLOWER CONTROL DIAL ..... 25</p> <p>    Discharge Air Flow ..... 25</p> <p>    System Description ..... 26</p> <p>        SWITCHES AND THEIR CONTROL FUNCTION.. 26</p> <p>    CAN Communication System Description ..... 27</p> <p><b>TROUBLE DIAGNOSIS ..... 28</b></p> <p>    CONSULT-II Function (HVAC) ..... 28</p> <p>        CONSULT-II BASIC OPERATION ..... 28</p> <p>        SELF-DIAGNOSIS ..... 29</p> <p>        DATA MONITOR ..... 29</p> <p>    CONSULT-II Function (BCM) ..... 31</p> <p>        CONSULT-II BASIC OPERATION ..... 31</p> <p>        DATA MONITOR ..... 32</p> <p>    How to Perform Trouble Diagnosis for Quick and Accurate Repair ..... 33</p> <p>        WORK FLOW ..... 33</p> <p>        SYMPTOM TABLE ..... 33</p> <p>    Component Parts and Harness Connector Location.. 34</p> <p>        ENGINE COMPARTMENT ..... 34</p> <p>        FRONT PASSENGER COMPARTMENT ..... 35</p> <p>    Schematic ..... 36</p>
---	---

MTC

Wiring Diagram — A/C — .....	37	INSPECTION FLOW .....	80
Front Air Control Terminals and Reference Value...	43	PERFORMANCE TEST DIAGNOSES .....	81
PIN CONNECTOR TERMINAL LAYOUT .....	43	PERFORMANCE CHART .....	83
TERMINALS AND REFERENCE VALUE FOR		TROUBLE DIAGNOSES FOR UNUSUAL PRES-	
FRONT AIR CONTROL .....	43	SURE .....	84
A/C System Self-diagnosis Function (With NAVI		Insufficient Heating .....	87
Only) .....	45	INSPECTION FLOW .....	87
DESCRIPTION .....	45	Noise .....	88
Operational Check .....	47	INSPECTION FLOW .....	88
CHECKING BLOWER .....	47	Self-diagnosis .....	89
CHECKING DISCHARGE AIR .....	47	INSPECTION FLOW .....	89
CHECKING RECIRCULATION .....	47	Water Valve Circuit .....	90
CHECKING TEMPERATURE DECREASE .....	48	COMPONENT DESCRIPTION .....	90
CHECKING TEMPERATURE INCREASE .....	48	DIAGNOSTIC PROCEDURE FOR WATER	
CHECK A/C SWITCH .....	48	VALVE .....	90
Power Supply and Ground Circuit for Front Air Con-		COMPONENT INSPECTION .....	92
trol .....	49	Intake Sensor Circuit .....	92
INSPECTION FLOW .....	49	COMPONENT DESCRIPTION .....	92
COMPONENT DESCRIPTION .....	50	DIAGNOSTIC PROCEDURE FOR INTAKE SEN-	
DIAGNOSTIC PROCEDURE FOR A/C SYSTEM..	50	SOR .....	92
Mode Door Motor Circuit .....	52	COMPONENT INSPECTION .....	94
INSPECTION FLOW .....	52	<b>CONTROL UNIT .....</b>	<b>95</b>
SYSTEM DESCRIPTION .....	53	Removal and Installation .....	95
COMPONENT DESCRIPTION .....	53	REMOVAL .....	95
DIAGNOSTIC PROCEDURE FOR MODE		INSTALLATION .....	95
DOOR MOTOR .....	53	<b>INTAKE SENSOR .....</b>	<b>96</b>
Air Mix Door Motor Circuit .....	56	Removal and Installation .....	96
INSPECTION FLOW .....	56	REMOVAL .....	96
SYSTEM DESCRIPTION .....	57	INSTALLATION .....	96
COMPONENT DESCRIPTION .....	57	<b>BLOWER MOTOR .....</b>	<b>97</b>
DIAGNOSTIC PROCEDURE FOR AIR MIX		Removal and Installation .....	97
DOOR MOTOR (FRONT) .....	58	REMOVAL .....	97
Intake Door Motor Circuit .....	60	INSTALLATION .....	97
INSPECTION FLOW .....	60	<b>IN-CABIN MICROFILTER .....</b>	<b>98</b>
SYSTEM DESCRIPTION .....	61	Removal and Installation .....	98
COMPONENT DESCRIPTION .....	61	FUNCTION .....	98
DIAGNOSTIC PROCEDURE FOR INTAKE		REPLACEMENT TIMING .....	98
DOOR MOTOR .....	62	REPLACEMENT PROCEDURE .....	98
Defroster Door Motor Circuit .....	63	<b>HEATER &amp; COOLING UNIT ASSEMBLY .....</b>	<b>100</b>
SYMPTOM: .....	63	Removal and Installation .....	100
INSPECTION FLOW .....	63	REMOVAL .....	100
SYSTEM DESCRIPTION .....	64	INSTALLATION .....	101
COMPONENT DESCRIPTION .....	64	<b>HEATER CORE .....</b>	<b>102</b>
DIAGNOSTIC PROCEDURE FOR		Removal and Installation .....	102
DEFROSTER DOOR MOTOR .....	64	REMOVAL .....	103
Front Blower Motor Circuit .....	67	INSTALLATION .....	103
INSPECTION FLOW .....	67	<b>DEFROSTER DOOR MOTOR .....</b>	<b>104</b>
SYSTEM DESCRIPTION .....	68	Removal and Installation .....	104
COMPONENT DESCRIPTION .....	68	REMOVAL .....	104
DIAGNOSTIC PROCEDURE FOR BLOWER		INSTALLATION .....	104
MOTOR .....	69	<b>INTAKE DOOR MOTOR .....</b>	<b>105</b>
COMPONENT INSPECTION .....	73	Removal and Installation .....	105
Magnet Clutch Circuit .....	74	REMOVAL .....	105
INSPECTION FLOW .....	74	INSTALLATION .....	105
SYSTEM DESCRIPTION .....	75	<b>MODE DOOR MOTOR .....</b>	<b>106</b>
DIAGNOSTIC PROCEDURE FOR MAGNET		Removal and Installation .....	106
CLUTCH .....	75	REMOVAL .....	106
COMPONENT INSPECTION .....	79	INSTALLATION .....	106
Insufficient Cooling .....	80		

<b>AIR MIX DOOR MOTOR</b> .....	<b>107</b>	INSTALLATION .....	119	
Removal and Installation .....	107	Removal and Installation for High-pressure Pipe .	120	A
REMOVAL .....	107	REMOVAL .....	120	
INSTALLATION .....	107	INSTALLATION .....	120	
<b>VARIABLE BLOWER CONTROL</b> .....	<b>108</b>	Removal and Installation for Low-pressure Pipe .	120	B
Removal and Installation .....	108	REMOVAL .....	120	
REMOVAL .....	108	INSTALLATION .....	120	
INSTALLATION .....	108	Removal and Installation for Refrigerant Pressure		
<b>DUCTS AND GRILLES</b> .....	<b>109</b>	Sensor .....	120	C
Removal and Installation .....	109	REMOVAL .....	120	
DEFROSTER NOZZLE .....	110	INSTALLATION .....	120	
RH AND LH SIDE DEMISTER DUCT .....	110	Removal and Installation for Condenser .....	120	D
RH AND LH VENTILATOR DUCT .....	110	REMOVAL .....	120	
CENTER VENTILATOR DUCT .....	111	INSTALLATION .....	121	
FLOOR DUCT .....	111	Removal and Installation for Evaporator .....	122	E
GRILLES .....	111	REMOVAL .....	122	
<b>REFRIGERANT LINES</b> .....	<b>112</b>	INSTALLATION .....	123	
HFC-134a (R-134a) Service Procedure .....	112	Removal and Installation for Expansion Valve .....	123	F
SETTING OF SERVICE TOOLS AND EQUIP-		REMOVAL .....	123	
MENT .....	112	INSTALLATION .....	123	
Components .....	114	Checking for Refrigerant Leaks .....	123	
Removal and Installation for Compressor .....	115	Checking System for Leaks Using the Fluorescent		G
REMOVAL .....	115	Dye Leak Detector .....	123	
INSTALLATION .....	116	Dye Injection .....	124	
Removal and Installation for Compressor Clutch ..	116	Electronic Refrigerant Leak Detector .....	124	H
REMOVAL .....	116	PRECAUTIONS FOR HANDLING LEAK		
INSPECTION .....	117	DETECTOR .....	124	
INSTALLATION .....	118	CHECKING PROCEDURE .....	125	I
BREAK-IN OPERATION .....	119	<b>SERVICE DATA AND SPECIFICATIONS (SDS) ...</b>	<b>127</b>	
Removal and Installation for Low-pressure Flexible		Service Data and Specifications (SDS) .....	127	
Hose .....	119	COMPRESSOR .....	127	MTC
REMOVAL .....	119	LUBRICANT .....	127	
INSTALLATION .....	119	REFRIGERANT .....	127	
Removal and Installation for High-pressure Flexible		ENGINE IDLING SPEED .....	127	
Hose .....	119	BELT TENSION .....	127	K
REMOVAL .....	119			

# PRECAUTIONS

## PRECAUTIONS

PF0:0001

### Precautions for Supplemental Restraint System (SRS) “AIR BAG” and “SEAT BELT PRE-TENSIONER”

EJS0031M

The Supplemental Restraint System such as “AIR BAG” and “SEAT BELT PRE-TENSIONER”, used along with a front seat belt, helps to reduce the risk or severity of injury to the driver and front passenger for certain types of collision. This system includes seat belt switch inputs and dual stage front air bag modules. The SRS system uses the seat belt switches to determine the front air bag deployment, and may only deploy one front air bag, depending on the severity of a collision and whether the front occupants are belted or unbelted. Information necessary to service the system safely is included in the SRS and SB section of this Service Manual.

#### **WARNING:**

- To avoid rendering the SRS inoperative, which could increase the risk of personal injury or death in the event of a collision which would result in air bag inflation, all maintenance must be performed by an authorized NISSAN/INFINITI dealer.
- Improper maintenance, including incorrect removal and installation of the SRS, can lead to personal injury caused by unintentional activation of the system. For removal of Spiral Cable and Air Bag Module, see the SRS section.
- Do not use electrical test equipment on any circuit related to the SRS unless instructed to in this Service Manual. SRS wiring harnesses can be identified by yellow and/or orange harnesses or harness connectors.

### Precautions for Working with HFC-134a (R-134a)

EJS0031N

#### **WARNING:**

- CFC-12 (R-12) refrigerant and HFC-134a (R-134a) refrigerant are not compatible. If the refrigerants are mixed compressor failure is likely to occur. Refer [MTC-4, "Contaminated Refrigerant"](#). To determine the purity of HFC-134a (R-134a) in the vehicle and recovery tank, use Refrigerant Recovery/Recycling Recharging equipment and Refrigerant Identifier.
- Use only specified lubricant for the HFC-134a (R-134a) A/C system and HFC-134a (R-134a) components. If lubricant other than that specified is used, compressor failure is likely to occur.
- The specified HFC-134a (R-134a) lubricant rapidly absorbs moisture from the atmosphere. The following handling precautions must be observed:
  - When removing refrigerant components from a vehicle, immediately cap (seal) the component to minimize the entry of moisture from the atmosphere.
  - When installing refrigerant components to a vehicle, do not remove the caps (unseal) until just before connecting the components. Connect all refrigerant loop components as quickly as possible to minimize the entry of moisture into system.
  - Only use the specified lubricant from a sealed container. Immediately reseal containers of lubricant. Without proper sealing, lubricant will become moisture saturated and should not be used.
  - Avoid breathing A/C refrigerant and lubricant vapor or mist. Exposure may irritate eyes, nose and throat. Remove HFC-134a (R-134a) from the A/C system using certified service equipment meeting requirements of SAE J2210 [HFC-134a (R-134a) recycling equipment], or J2209 [HFC-134a (R-134a) recovery equipment]. If accidental system discharge occurs, ventilate work area before resuming service. Additional health and safety information may be obtained from refrigerant and lubricant manufacturers.
  - Do not allow lubricant, NISSAN A/C System Lubricant Type S (DH-PS) or equivalent, to come in contact with styrofoam parts. Damage may result.

### Contaminated Refrigerant

EJS0031O

If a refrigerant other than pure HFC-134a (R-134a) is identified in a vehicle, your options are:

- Explain to the customer that environmental regulations prohibit the release of contaminated refrigerant into the atmosphere.
- Explain that recovery of the contaminated refrigerant could damage your service equipment and refrigerant supply.
- Suggest the customer return the vehicle to the location of previous service where the contamination may have occurred.

# PRECAUTIONS

- If you choose to perform the repair, recover the refrigerant using only **dedicated equipment and containers. Do not recover contaminated refrigerant into your existing service equipment.** If your facility does not have dedicated recovery equipment, you may contact a local refrigerant product retailer for available service. This refrigerant must be disposed of in accordance with all federal and local regulations. In addition, replacement of all refrigerant system components on the vehicle is recommended.
- If the vehicle is within the warranty period, the air conditioner warranty is void. Please contact NISSAN Customer Affairs for further assistance.

## General Refrigerant Precautions

EJS0031P

### WARNING:

- **Do not release refrigerant into the air. Use approved recovery/recycling equipment to capture the refrigerant every time an air conditioning system is discharged.**
- **Always wear eye and hand protection (goggles and gloves) when working with any refrigerant or air conditioning system.**
- **Do not store or heat refrigerant containers above 52°C (125°F).**
- **Do not heat a refrigerant container with an open flame; if container warming is required, place the bottom of the container in a warm pail of water.**
- **Do not intentionally drop, puncture, or incinerate refrigerant containers.**
- **Keep refrigerant away from open flames: poisonous gas will be produced if refrigerant burns.**
- **Refrigerant will displace oxygen, therefore be certain to work in well ventilated areas to prevent suffocation.**
- **Do not pressure test or leak test HFC-134a (R-134a) service equipment and/or vehicle air conditioning systems with compressed air during repair. Some mixtures of air and HFC-134a (R-134a) have been shown to be combustible at elevated pressures. These mixtures, if ignited, may cause injury or property damage. Additional health and safety information may be obtained from refrigerant manufacturers.**

## Precautions for Leak Detection Dye

EJS0031Q

- The A/C system contains a fluorescent leak detection dye used for locating refrigerant leaks. An ultraviolet (UV) lamp is required to illuminate the dye when inspecting for leaks.
- Always wear fluorescence enhancing UV safety goggles to protect your eyes and enhance the visibility of the fluorescent dye.
- The fluorescent dye leak detector is not a replacement for an electronic refrigerant leak detector. The fluorescent dye leak detector should be used in conjunction with an electronic refrigerant leak detector (J-41995).
- For your safety and the customer's satisfaction, read and follow all manufacturer's operating instructions and precautions prior to performing work.
- A compressor shaft seal should not be repaired because of dye seepage. The compressor shaft seal should only be repaired after confirming the leak with an electronic refrigerant leak detector (J-41995).
- Always remove any dye from the leak area after repairs are complete to avoid a misdiagnosis during a future service.
- Do not allow dye to come into contact with painted body panels or interior components. If dye is spilled, clean immediately with the approved dye cleaner. Fluorescent dye left on a surface for an extended period of time **cannot be removed**.
- Do not spray the fluorescent dye cleaning agent on hot surfaces (engine exhaust manifold, etc.).
- Do not use more than one refrigerant dye bottle (1/4 ounce / 7.4 cc) per A/C system.
- Leak detection dyes for HFC-134a (R-134a) and CFC-12 (R-12) A/C systems are different. Do not use HFC-134a (R-134a) leak detection dye in CFC-12 (R-12) A/C systems or CFC-12 (R-12) leak detection dye in HFC-134a (R-134a) A/C systems or A/C system damage may result.
- The fluorescent properties of the dye will remain for over three (3) years unless a compressor failure occurs.

A

B

C

D

E

F

G

H

I

MTC

K

L

M

# PRECAUTIONS

EJS0031R

## A/C Identification Label

Vehicles with factory installed fluorescent dye have this identification label on the underside of hood.

AIR CONDITIONER NISSAN			
		REFRIGERANT	COMPRESSOR LUBRICANT
TYPE (PART NO.)		HFC 134a (R134a)	NISSAN LUMINOUS OIL TYPE S (KLH00-PAGS0)
AMOUNT	W/OUT RR	0.70 ± 0.05 kg (1.54 ± 0.11 lbs)	200 ml. (6.8 oz.)
	W/RR	1.08 ± 0.05 kg (2.38 ± 0.11 lbs)	290 ml. (9.8 oz.)

**CAUTION**  
PRECAUTION

- REFRIGERANT UNDER HIGH PRESSURE.
- SYSTEM TO BE SERVICED BY QUALIFIED PERSONNEL.
- IMPROPER SERVICE METHODS MAY CAUSE PERSONAL INJURY.
- CONSULT SERVICE MANUAL.
- THIS AIR CONDITIONER SYSTEM COMPLIES WITH SAE J-639.

Nissan Motor Corporation in USA, Carson, CA  
27090 7S000

WJIA0672E

## Precautions for Refrigerant Connection

EJS0031S

A new type refrigerant connection has been introduced to all refrigerant lines except the following locations.

- Expansion valve to cooling unit
- Evaporator pipes to evaporator (inside cooling unit)
- Refrigerant pressure sensor

## FEATURES OF NEW TYPE REFRIGERANT CONNECTION

- The O-ring has been relocated. It has also been provided with a groove for proper installation. This reduces the possibility of the O-ring being caught in, or damaged by, the mating part. The sealing direction of the O-ring is now set vertically in relation to the contacting surface of the mating part to improve sealing characteristics.
- The reaction force of the O-ring will not occur in the direction that causes the joint to pull out, thereby facilitating piping connections.

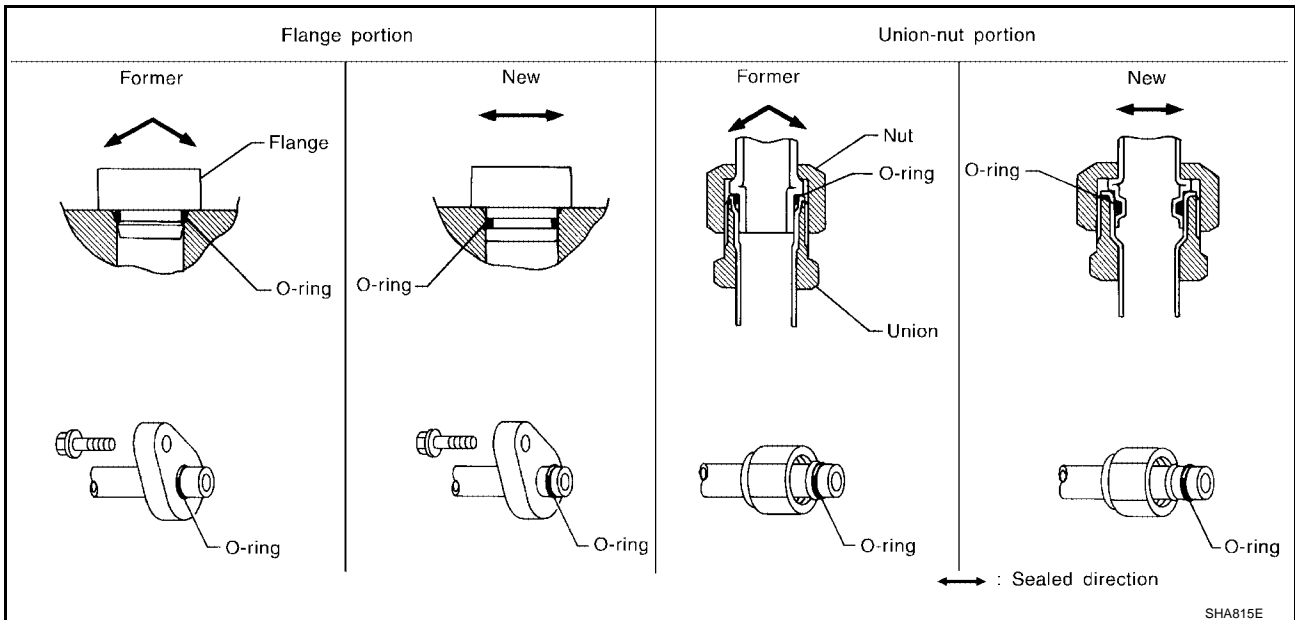

# PRECAUTIONS

## O-RING AND REFRIGERANT CONNECTION

### A/C Compressor and Condenser

SEC. 214 • 271 • 274 • 276

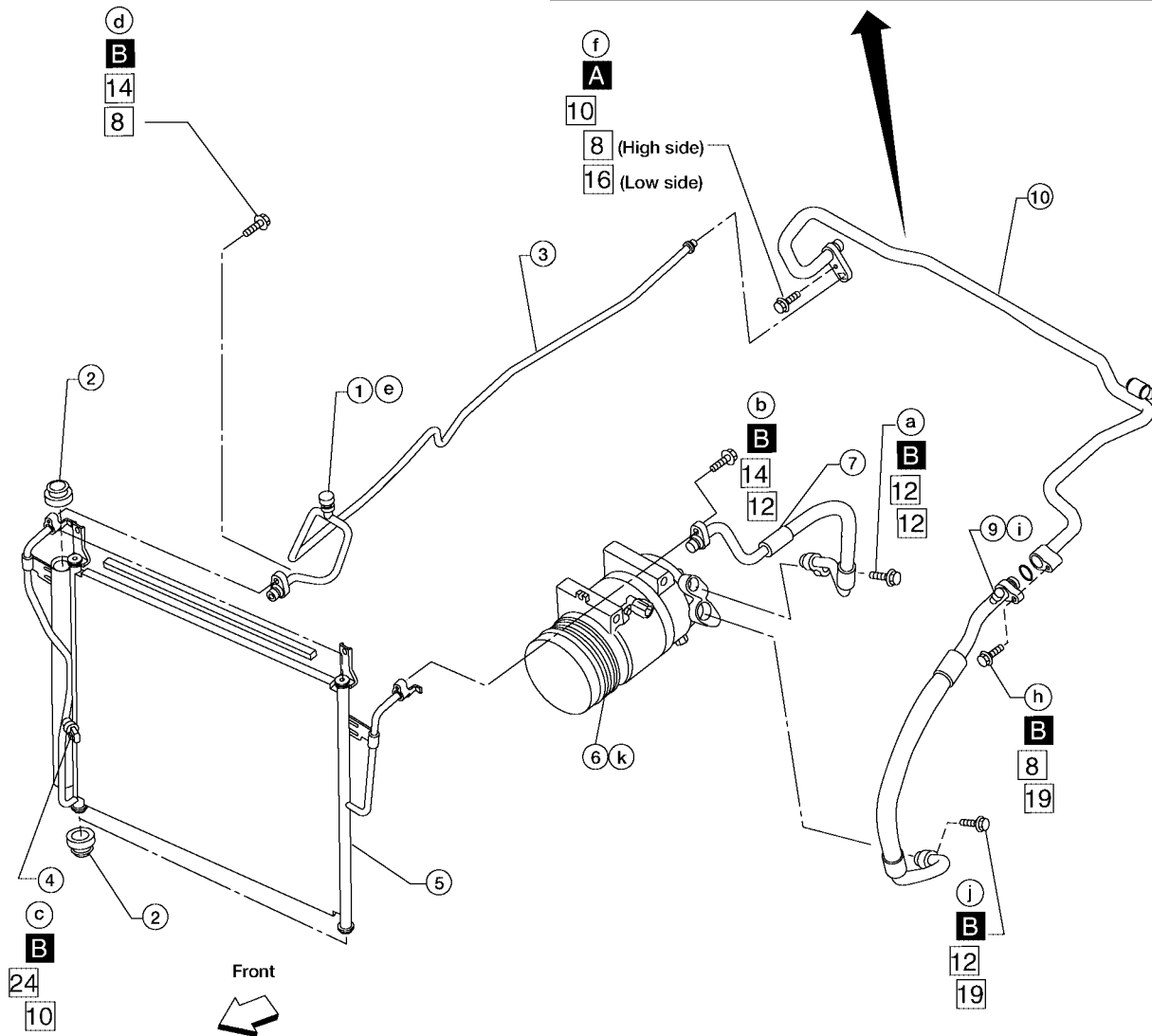
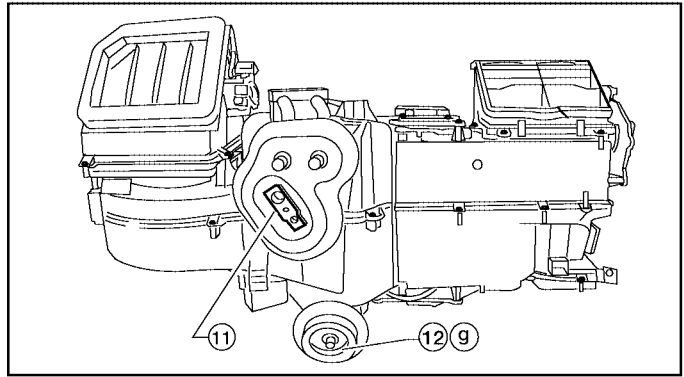

- : Refrigerant leak checking order (a-k)
- : Tightening torque
- : Wrench size
- : O-ring size
- ⊗ : N-m (kg-m, in-lb)
- A ⊗ : 3.4 (0.35 , 30)
- B ⊗ : 9.3 (0.95 , 82)

WJIA1020E

A  
B  
C  
D  
E  
F  
G  
H  
I  
MTC  
K  
L  
M

# PRECAUTIONS

- |                                |                               |                               |
|--------------------------------|-------------------------------|-------------------------------|
| 1. High-pressure service valve | 2. Grommet                    | 3. High-pressure pipe         |
| 4. Refrigerant pressure sensor | 5. Condenser                  | 6. Compressor shaft seal      |
| 7. High-pressure flexible hose | 8. Low-pressure flexible hose | 9. Low-pressure service valve |
| 10. Low-pressure pipe          | 11. Expansion valve           | 12. Drain hose                |

## CAUTION:

The new and former refrigerant connections use different O-ring configurations. Do not confuse O-rings since they are not interchangeable. If a wrong O-ring is installed, refrigerant will leak at or around the connection.

## O-Ring Part Numbers and Specifications

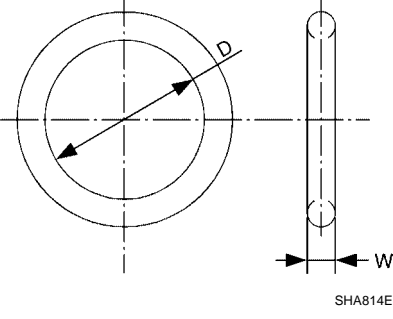
	Connec- tion type	O-ring size	Part number*	D mm (in)	W mm (in)
	New	8	92471 N8210	6.8 (0.268)	1.85 (0.0728)
	Former	10	J2476 89956	9.25 (0.3642)	1.78 (0.0701)
	New	12	92472 N8210	10.9 (0.429)	2.43 (0.0957)
	Former		92475 71L00	11.0 (0.433)	2.4 (0.094)
	New	16	92473 N8210	13.6 (0.535)	2.43 (0.0957)
	Former		92475 72L00	14.3 (0.563)	2.3 (0.091)
	New	19	92474 N8210	16.5 (0.650)	2.43 (0.0957)
	Former		92477 N8200	17.12 (0.6740)	1.78 (0.0701)
	New	24	92195 AH300	21.8 (0.858)	2.4 (0.094)

\*: Always check with the Parts Department for the latest parts information.

## WARNING:

Make sure all refrigerant is discharged into the recycling equipment and the pressure in the system is less than atmospheric pressure. Then gradually loosen the discharge side hose fitting and remove it.

## CAUTION:

When replacing or cleaning refrigerant cycle components, observe the following.

- When the compressor is removed, store it in the same position as it is when mounted on the car. Failure to do so will cause lubricant to enter the low pressure chamber.
- When connecting tubes, always use a torque wrench and a back-up wrench.
- After disconnecting tubes, immediately plug all openings to prevent entry of dirt and moisture.
- When installing an air conditioner in the vehicle, connect the pipes as the final stage of the operation. Do not remove the seal caps of pipes and other components until just before required for connection.
- Allow components stored in cool areas to warm to working area temperature before removing seal caps. This prevents condensation from forming inside A/C components.
- Thoroughly remove moisture from the refrigeration system before charging the refrigerant.
- Always replace used O-rings.
- When connecting tube, apply lubricant to circle of the O-rings shown in illustration. Be careful not to apply lubricant to threaded portion.  
Lubricant name: NISSAN A/C System Lubricant Type S (DH-PS)  
Part number: KLH00-PAGS0
- O-ring must be closely attached to dented portion of tube.
- When replacing the O-ring, be careful not to damage O-ring and tube.
- Connect tube until you hear it click, then tighten the nut or bolt by hand until snug. Make sure that the O-ring is installed to tube correctly.



# PRECAUTIONS

- After connecting line, conduct leak test and make sure that there is no leakage from connections. When the gas leaking point is found, disconnect that line and replace the O-ring. Then tighten connections of seal seat to the specified torque.

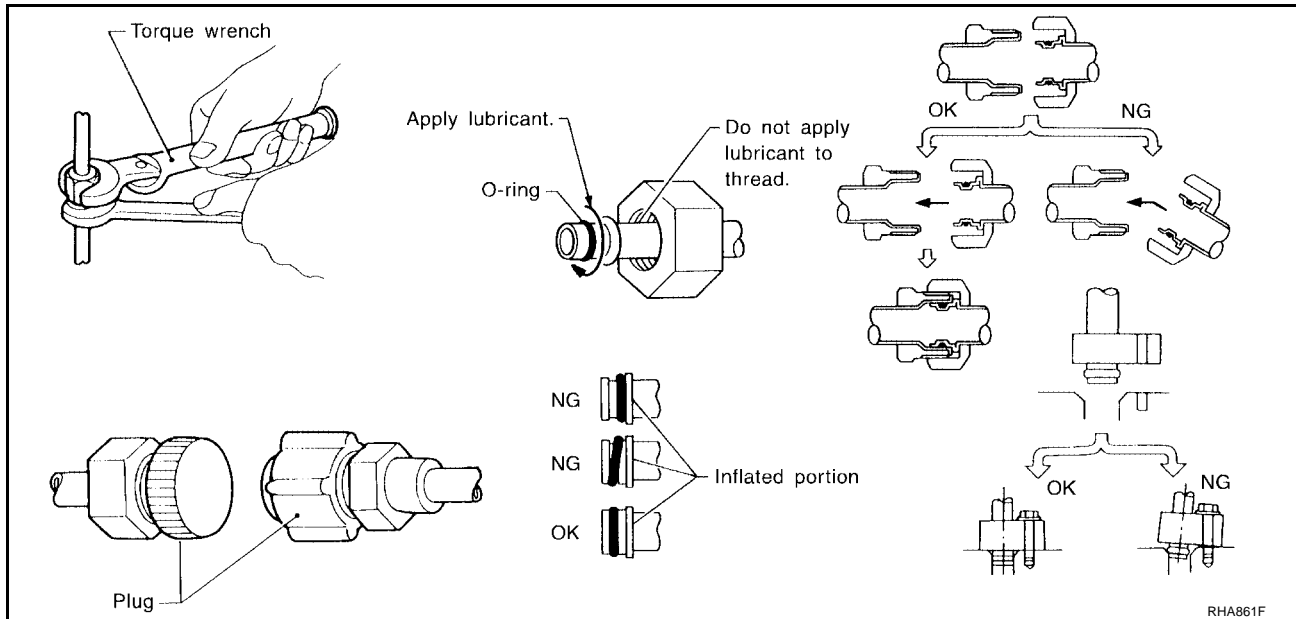

## Precautions for Servicing Compressor

EJS0031T

- Plug all openings to prevent moisture and foreign matter from entering.
- When the compressor is removed, store it in the same position as it is when mounted on the car.
- When replacing or repairing compressor, follow "Maintenance of Lubricant Quantity in Compressor" exactly. Refer to [MTC-20, "Maintenance of Lubricant Quantity in Compressor"](#).
- Keep friction surfaces between clutch and pulley clean. If the surface is contaminated with lubricant, wipe it off by using a clean waste cloth moistened with thinner.
- After compressor service operation, turn the compressor shaft by hand more than 5 turns in both directions. This will equally distribute lubricant inside the compressor. After the compressor is installed, let the engine idle and operate the compressor for 1 hour.
- After replacing the compressor magnet clutch, apply voltage to the new one and check for normal operation. Refer to [MTC-116, "Removal and Installation for Compressor Clutch"](#).

## Precautions for Service Equipment RECOVERY/RECYCLING EQUIPMENT

EJS0031U

Follow the manufacturer's instructions for machine operation and machine maintenance. Never introduce any refrigerant other than that specified into the machine.

## ELECTRONIC LEAK DETECTOR

Follow the manufacturer's instructions for tester operation and tester maintenance.

# PRECAUTIONS

## VACUUM PUMP

The lubricant contained inside the vacuum pump is not compatible with the specified lubricant for HFC-134a (R-134a) A/C systems. The vent side of the vacuum pump is exposed to atmospheric pressure so the vacuum pump lubricant may migrate out of the pump into the service hose. This is possible when the pump is switched off after evacuation (vacuuming) and hose is connected to it. To prevent this migration, use a manual valve situated near the hose-to-pump connection, as follows.

- Usually vacuum pumps have a manual isolator valve as part of the pump. Close this valve to isolate the service hose from the pump.
- For pumps without an isolator, use a hose equipped with a manual shut-off valve near the pump end. Close the valve to isolate the hose from the pump.
- If the hose has an automatic shut off valve, disconnect the hose from the pump: as long as the hose is connected, the valve is open and lubricating oil may migrate.

Some one-way valves open when vacuum is applied and close under a no vacuum condition. Such valves may restrict the pump's ability to pull a deep vacuum and are not recommended.

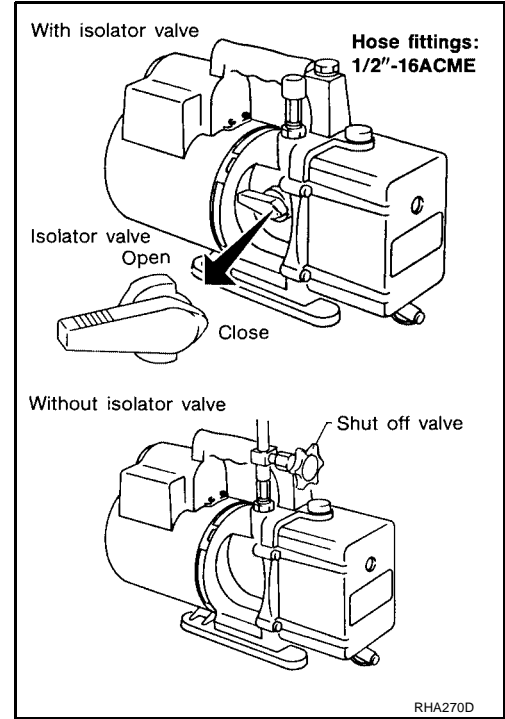

## MANIFOLD GAUGE SET

Be certain that the gauge face indicates HFC-134a (R-134a or 134a). Make sure the gauge set has 1/2"-16 ACME threaded connections for service hoses. Confirm the set has been used only with refrigerant HFC-134a (R-134a) along with specified lubricant.

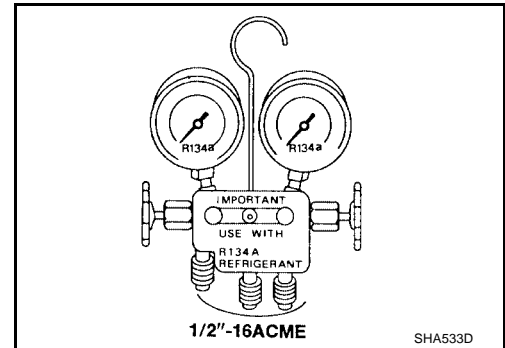

## SERVICE HOSES

Be certain that the service hoses display the markings described (colored hose with black stripe). All hoses must include positive shut-off devices (either manual or automatic) near the end of the hoses opposite the manifold gauge.

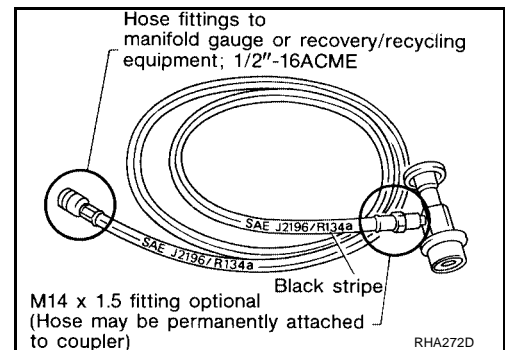

# PRECAUTIONS

## SERVICE COUPLERS

Never attempt to connect HFC-134a (R-134a) service couplers to a CFC-12 (R-12) A/C system. The HFC-134a (R-134a) couplers will not properly connect to the CFC-12 (R-12) system. If an improper connection is attempted, discharging and contamination may occur.

Shut-off valve rotation	A/C service valve
Clockwise	Open
Counterclockwise	Close

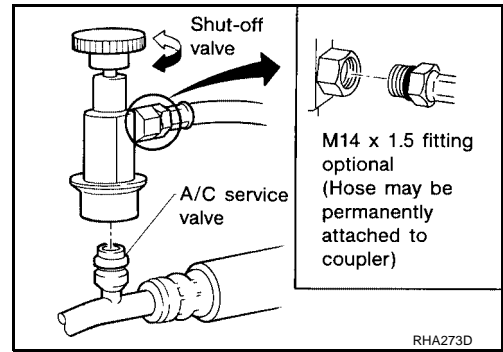

## REFRIGERANT WEIGHT SCALE

Verify that no refrigerant other than HFC134a (R-134a) and specified lubricants have been used with the scale. If the scale controls refrigerant flow electronically, the hose fitting must be 1/2"-16 ACME.

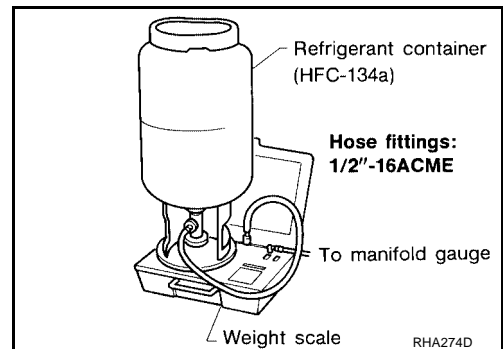

## CHARGING CYLINDER

Using a charging cylinder is not recommended. Refrigerant may be vented into air from cylinder's top valve when filling the cylinder with refrigerant. Also, the accuracy of the cylinder is generally less than that of an electronic scale or of quality recycle/recharge equipment.

## Wiring Diagrams and Trouble Diagnosis

EJS0031V

MTC

When you read wiring diagrams, refer to the following:

- [GI-14, "How to Read Wiring Diagrams"](#)
- [PG-4, "POWER SUPPLY ROUTING CIRCUIT"](#)

When you perform trouble diagnosis, refer to the following:

- [GI-9, "How to Follow Trouble Diagnoses"](#)
- [GI-27, "How to Perform Efficient Diagnosis for an Electrical Incident"](#)

# PREPARATION

## PREPARATION

PF0:0002

### Special Service Tools

EJS003RG

The actual shapes of Kent-Moore tools may differ from those of special service tools illustrated here.

Tool number (Kent-Moore No.) Tool name	Description
— (J-38873-A) Pulley installer	Installing pulley
KV99233130 (J-29884) Pulley puller	Removing pulley

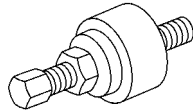

LHA171

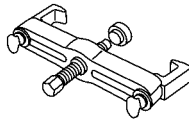

LHA172

## HFC-134a (R-134a) Service Tools and Equipment

EJS003RH

Never mix HFC-134a (R-134a) refrigerant and/or the specified lubricant with CFC-12 (R-12) refrigerant and/or the lubricant.

Separate and non-interchangeable service equipment must be used for handling each type of refrigerant/lubricant.

Refrigerant container fittings, service hose fittings and service equipment fittings (equipment which handles refrigerant and/or lubricant) are different between CFC-12 (R-12) and HFC-134a (R-134a). This is to avoid mixed use of the refrigerants/lubricant.

Adapters that convert one size fitting to another must never be used refrigerant/lubricant contamination will occur and compressor failure will result.

Tool number (Kent-Moore No.) Tool name	Description
HFC-134a (R-134a) ( — ) Refrigerant	Container color: Light blue Container marking: HFC-134a (R-134a) Fitting size: Thread size ● large container 1/2"-16 ACME
KLH00-PAGRO ( — ) NISSAN A/C System Lubricant Type S (DH-PS)	Type: Poly alkylene glycol oil (PAG), type S (DH-PS) Application: HFC-134a (R-134a) swash plate compressors (NISSAN only) Lubricity: 40 mℓ (1.4 US fl oz, 1.4 Imp fl oz)
— (J-43600) Recovery/Recycling Recharging equipment (ACR2000)	Refrigerant Recovery and Recycling and Recharging

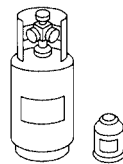

S-NT196





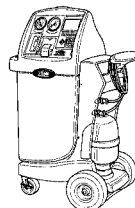

S-NT197



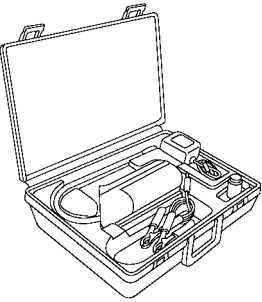
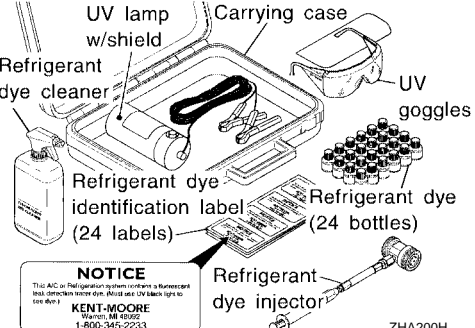
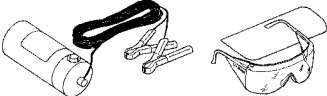

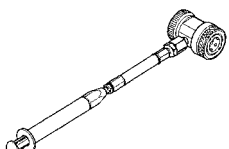
WJIA0293E

# PREPARATION

Tool number (Kent-Moore No.) Tool name	Description	
<p>— (J-41995) Electronic refrigerant leak detector</p>  <p style="text-align: right;">AHA281A</p>	<p>Power supply: ● DC 12V (battery terminal)</p>	A B C D
<p>— (J-43926) Refrigerant dye leak detection kit Kit includes: (J-42220) UV lamp and UV safety goggles (J-41459) Refrigerant dye injector (J-41447) qty. 24 HFC-134a (R-134a) refrigerant dye (J-43872) Refrigerant dye cleaner</p>  <p style="text-align: right;">ZHA200H</p>	<p>Power supply: ● DC 12V (battery terminal)</p>	E F G H
<p>— (J-42220) Fluorescent dye leak detector</p>  <p style="text-align: right;">SHA438F</p>	<p>Power supply: ● DC 12V (battery terminal)</p> <p>For checking refrigerant leak when fluorescent dye is installed in A/C system. Includes: UV lamp and UV safety goggles</p>	I <b>MTC</b>
<p>— (J-41447) HFC-134a (R-134a) Fluorescent leak detection dye (Box of 24, 1/4 ounce bottles)</p>  <p style="text-align: right;">SHA439F</p>	<p>Application: For HFC-134a (R-134a) PAG oil Container: 1/4 ounce (7.4cc) bottle (Includes self-adhesive dye identification labels for affixing to vehicle after charging system with dye.)</p>	K L
<p>— (J-41459) HFC-134a (R-134a) Dye injector Use with J-41447, 1/4 ounce bottle</p>  <p style="text-align: right;">SHA440F</p>	<p>For injecting 1/4 ounce of fluorescent leak detection dye into A/C system.</p>	M
<p>— (J-43872) Refrigerant dye cleaner</p>  <p style="text-align: right;">SHA441F</p>	<p>For cleaning dye spills.</p>	

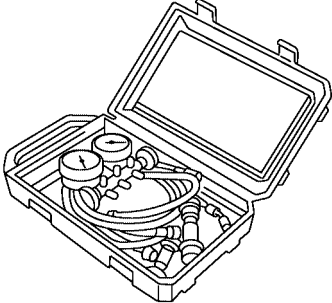
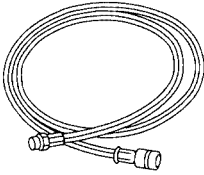
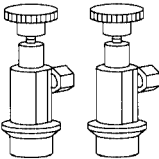

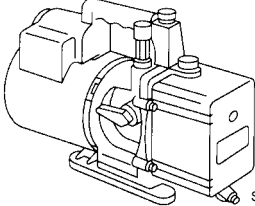
# PREPARATION

Tool number (Kent-Moore No.) Tool name	Description
<p>— (J-39183-C) Manifold gauge set (with hoses and couplers)</p>  <p style="text-align: right; font-size: small;">RJIA0196E</p>	<p>Identification:</p> <ul style="list-style-type: none"> <li>● The gauge face indicates R-134a. Fitting size-Thread size</li> <li>● 1/2"-16 ACME</li> </ul>
<p>Service hoses:</p> <ul style="list-style-type: none"> <li>● High side hose (J-39500-72B)</li> <li>● Low side hose (J-39500-72R)</li> <li>● Utility hose (J-39500-72Y)</li> </ul>  <p style="text-align: right; font-size: small;">S-NT201</p>	<p>Hose color:</p> <ul style="list-style-type: none"> <li>● Low side hose: Blue with black stripe</li> <li>● High side hose: Red with black stripe</li> <li>● Utility hose: Yellow with black stripe or green with black stripe</li> </ul> <p>Hose fitting to gauge:</p> <ul style="list-style-type: none"> <li>● 1/2"-16 ACME</li> </ul>
<p>Service couplers</p> <ul style="list-style-type: none"> <li>● High side coupler (J-39500-20A)</li> <li>● Low side coupler (J-39500-24A)</li> </ul>  <p style="text-align: right; font-size: small;">S-NT202</p>	<p>Hose fitting to service hose:</p> <ul style="list-style-type: none"> <li>● M14 x 1.5 fitting is optional or permanently attached.</li> </ul>
<p>— (J-39699) Refrigerant weight scale</p>  <p style="text-align: right; font-size: small;">S-NT200</p>	<p>For measuring of refrigerant Fitting size-Thread size</p> <ul style="list-style-type: none"> <li>● 1/2"-16 ACME</li> </ul>
<p>— (J-39649) Vacuum pump (Including the isolator valve)</p>  <p style="text-align: right; font-size: small;">S-NT203</p>	<p>Capacity:</p> <ul style="list-style-type: none"> <li>● Air displacement: 4 CFM</li> <li>● Micron rating: 20 microns</li> <li>● Oil capacity: 482 g (17 oz)</li> </ul> <p>Fitting size-Thread size</p> <ul style="list-style-type: none"> <li>● 1/2"-16 ACME</li> </ul>

# PREPARATION

## Commercial Service Tools

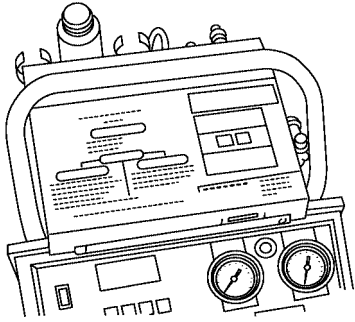
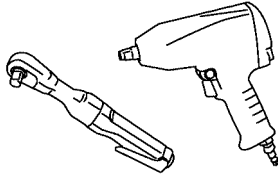
EJS003RI

Tool name	Description	A
<p>(J-41810-NI) Refrigerant identifier equipment (R-134a)</p>  <p style="text-align: right; font-size: small;">RJIA0197E</p>	<p>For checking refrigerant purity and system contamination</p>	B C D
<p>Power tool</p>  <p style="text-align: right; font-size: small;">PBIC0190E</p>	<p>Loosening bolts and nuts</p>	E F
<p>(J-44614) Clutch disc holding tool</p>  <p style="text-align: right; font-size: small;">WHA230</p>	<p>Clutch disc holding tool</p>	G H I

MTC

K  
L  
M

# REFRIGERATION SYSTEM

---

## REFRIGERATION SYSTEM

PPF:KA990

### Refrigerant Cycle REFRIGERANT FLOW

EJS0031Z

The refrigerant flows in the standard pattern, that is, through the compressor, the condenser with liquid tank, through the evaporator, and back to the compressor. The refrigerant evaporation through the evaporator coils are controlled by externally equalized expansion valve, located inside the evaporator case.

### Refrigerant System Protection REFRIGERANT PRESSURE SENSOR

EJS00320

The refrigerant system is protected against excessively high or low pressures by the refrigerant pressure sensor, located on the condenser. If the system pressure rises above or falls below the specifications, the refrigerant pressure sensor detects the pressure inside the refrigerant line and sends a voltage signal to the ECM. The ECM de-energizes the A/C relay to disengage the magnetic compressor clutch when pressure on the high pressure side detected by refrigerant pressure sensor is over about 2,746 kPa (28 kg/cm<sup>2</sup> , 398 psi), or below about 120 kPa (1.22 kg/cm<sup>2</sup> , 17.4 psi).



# REFRIGERATION SYSTEM

## PRESSURE RELIEF VALVE

The refrigerant system is also protected by a pressure relief valve, located in the rear head of the compressor. When the pressure of refrigerant in the system increases to an abnormal level [more than 2,990 kPa (30.5 kg/cm<sup>2</sup> , 433.6 psi)], the release port on the pressure relief valve automatically opens and releases refrigerant into the atmosphere.

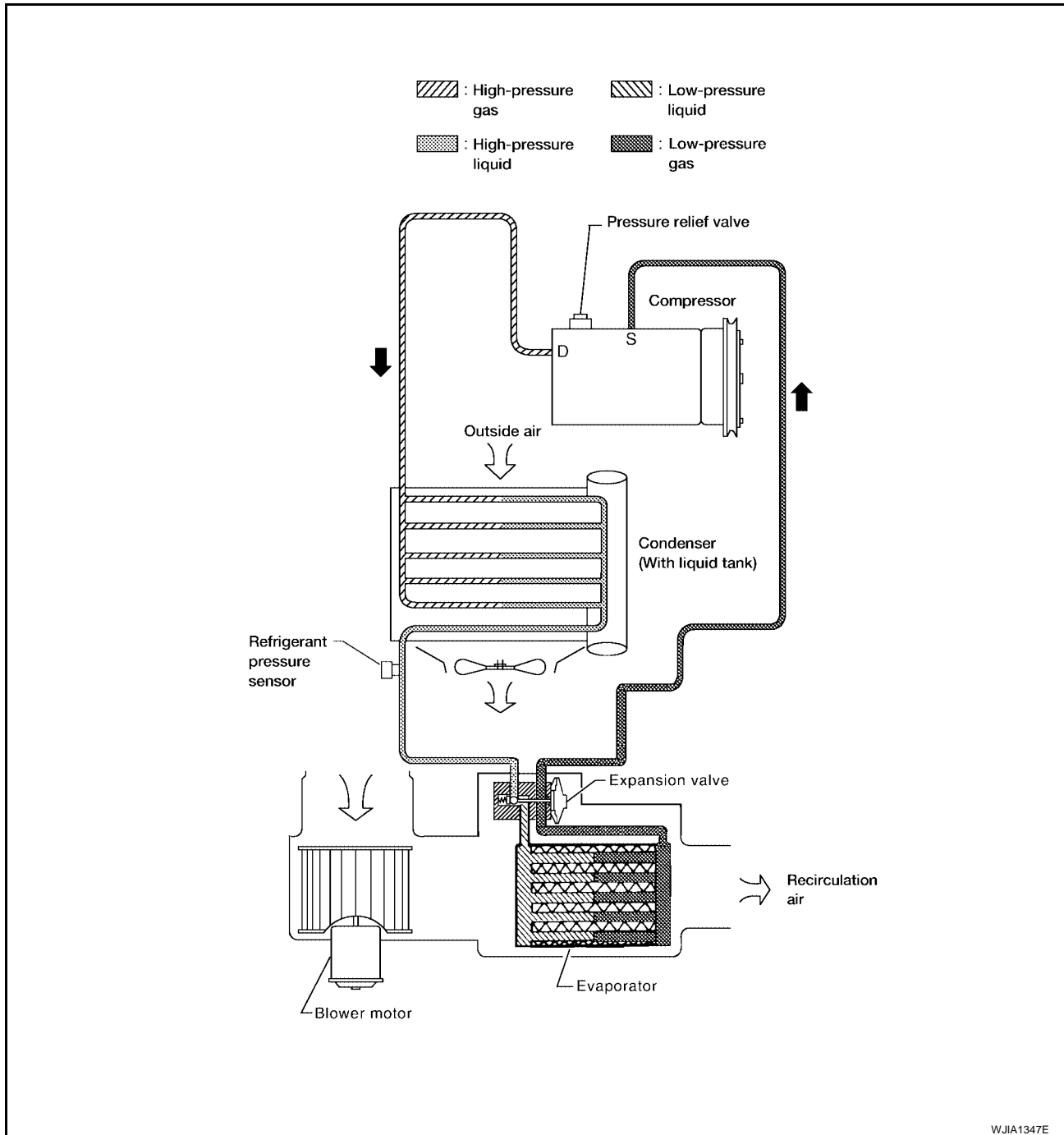

A  
B  
C  
D  
E  
F  
G  
H  
I  
MTC  
K  
L  
M

# REFRIGERATION SYSTEM

EJS00321

## Component Layout REFRIGERATION SYSTEM

SEC. 270 • 271

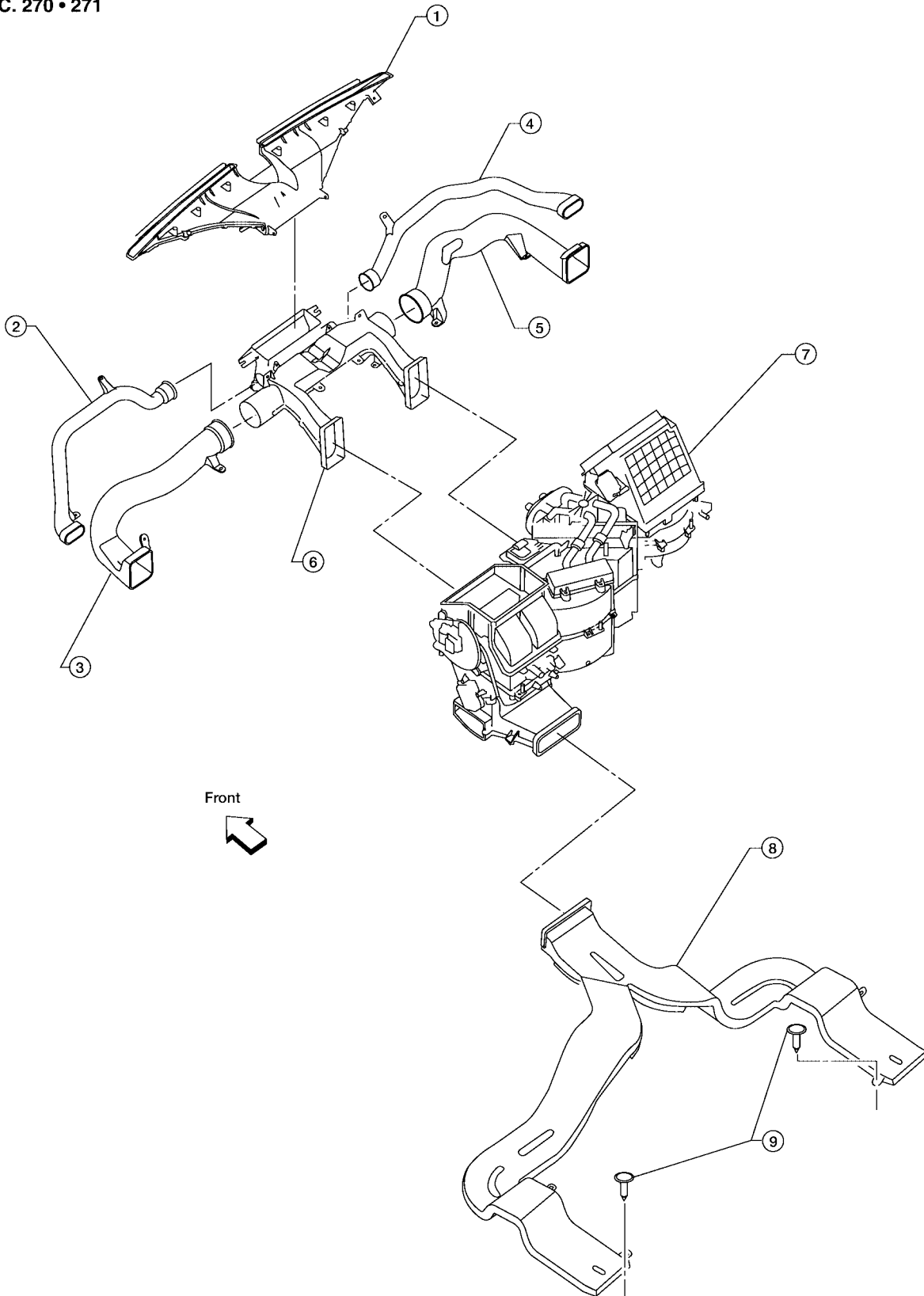

LJIA0141E

# REFRIGERATION SYSTEM

---

- |                                     |                          |                           |
|-------------------------------------|--------------------------|---------------------------|
| 1. Defroster nozzle                 | 2. LH side demister duct | 3. LH ventilator duct     |
| 4. RH side demister duct            | 5. RH ventilator duct    | 6. Center ventilator duct |
| 7. Heater and cooling unit assembly | 8. Floor duct            | 9. Clips                  |

A

B

C

D

E

F

G

H

I

MTC

K

L

M

## LUBRICANT

PFP:KLG00

### Maintenance of Lubricant Quantity in Compressor

EJS00322

The lubricant in the compressor circulates through the system with the refrigerant. Add lubricant to compressor when replacing any component or after a large refrigerant leakage has occurred. It is important to maintain the specified amount.

If lubricant quantity is not maintained properly, the following malfunctions may result:

- Lack of lubricant: May lead to a seized compressor
- Excessive lubricant: Inadequate cooling (thermal exchange interference)

## LUBRICANT

**Name: NISSAN A/C System Lubricant Type S (DH-PS)**

**Part number: KLH00-PAGS0**

### CHECKING AND ADJUSTING

#### CAUTION:

**If excessive lubricant leakage is noted, do not perform the lubricant return operation.**

Start the engine and set the following conditions:

#### test condition

- **Engine speed: Idling to 1,200 rpm**
- **A/C switch: On**
- **Blower speed: Max. position**
- **Temperature control: Optional [set so that intake air temperature is 25° to 30° C (77° to 86°F).]**
- **Intake position: Recirculation (  )**
- **Perform lubricant return operation for about ten minutes**

Adjust the lubricant quantity according to the following table.

### Lubricant Adjusting Procedure for Components Replacement Except Compressor

After replacing any of the following major components, add the correct amount of lubricant to the system.

#### Amount of lubricant to be added:

Part replaced	Lubricant to be added to system		Remarks
	Amount of lubricant m ℓ (US fl oz, Imp fl oz)		
Front evaporator	75 (2.5, 2.6)		—
Condenser	75 (2.5, 2.6)		—
Liquid tank	5 (0.2, 0.2)		Add if compressor is not replaced.
In case of refrigerant leak	30 (1.0, 1.1)		Large leak
	—		Small leak *1

\*1: If refrigerant leak is small, no addition of lubricant is needed.

### Lubricant Adjustment Procedure for Compressor Replacement

1. Before connecting recovery/recycling equipment to vehicle, check recovery/recycling equipment gauges. No refrigerant pressure should be displayed. If NG, recover refrigerant from equipment lines.
2. Connect recovery/recycling equipment to vehicle. Confirm refrigerant purity in supply tank using recovery/recycling equipment and refrigerant identifier. If NG, refer to [MTC-4, "Contaminated Refrigerant"](#) .
3. Confirm refrigerant purity in vehicle A/C system using recovery/recycling equipment and refrigerant identifier. If NG, refer to [MTC-4, "Contaminated Refrigerant"](#) .
4. Discharge refrigerant into the refrigerant recovery/recycling equipment. Measure lubricant discharged into the recovery/recycling equipment.
5. Drain the lubricant from the "old" (removed) compressor into a graduated container and recover the amount of lubricant drained.
6. Drain the lubricant from the "new" compressor into a separate, clean container.
7. Measure an amount of new lubricant installed equal to amount drained from "old" compressor. Add this lubricant to "new" compressor through the suction port opening.

# LUBRICANT

8. Measure an amount of new lubricant equal to the amount recovered during discharging. Add this lubricant to "new" compressor through the suction port opening.
9. If the liquid tank also needs to be replaced, add an additional 5 mℓ (0.2 US fl oz, 0.2 Imp fl oz) of lubricant at this time.  
**Do not add this 5 mℓ (0.2 US fl oz, 0.2 Imp fl oz) of lubricant if only replacing the compressor.**

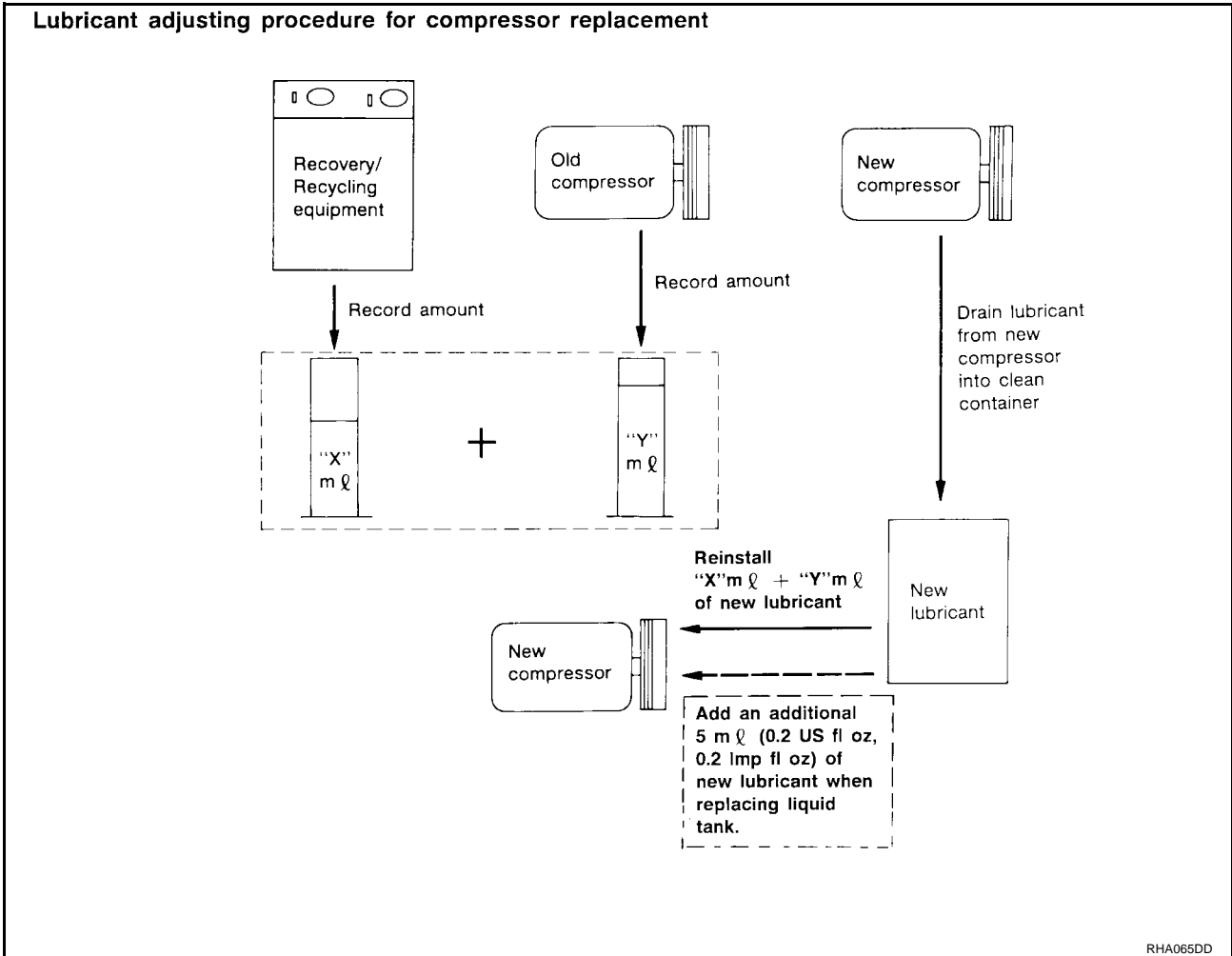

A  
B  
C  
D  
E  
F  
G  
H  
I  
K  
L  
M

MTC

# AIR CONDITIONER CONTROL

## AIR CONDITIONER CONTROL

PFP:27500

### Description

EJS003TN

The front air control provides regulation of the vehicle's interior temperature. The system is based on the position of the front air controls temperature switch selected by the driver. This is done by utilizing a microcomputer, also referred to as the front air control, which receives input signals from the following two sensors:

- Intake sensor
- PBR (Position Balanced Resistor).

The front air control uses these signals (including the set position of the temperature switch) to control:

- Outlet air volume
- Air temperature
- Air distribution

### Operation

EJS003TO

#### AIR MIX DOOR CONTROL

The air mix door is controlled so that in-vehicle temperature changed based on the position of the temperature switch.

#### BLOWER SPEED CONTROL

Blower speed is controlled based on front blower switch settings.

When blower switch is turned, the blower motor starts and increases air flow volume each time the blower switch is turned clockwise, and decreases air flow volume each time the blower switch is turned counterclockwise.

When engine coolant temperature is low, the blower motor operation is delayed to prevent cool air from flowing.

#### INTAKE DOORS CONTROL

The intake doors are controlled by the recirculation switch setting, and the mode (recirculation is not allowed in floor, floor/defrost or defrost modes) control dial setting.

#### MODE DOOR CONTROL

The mode door is controlled by the position of the mode control dial.

#### DEFROSTER DOOR CONTROL

The defroster door is controlled by turning the defroster dial to front defroster.

#### MAGNET CLUTCH CONTROL

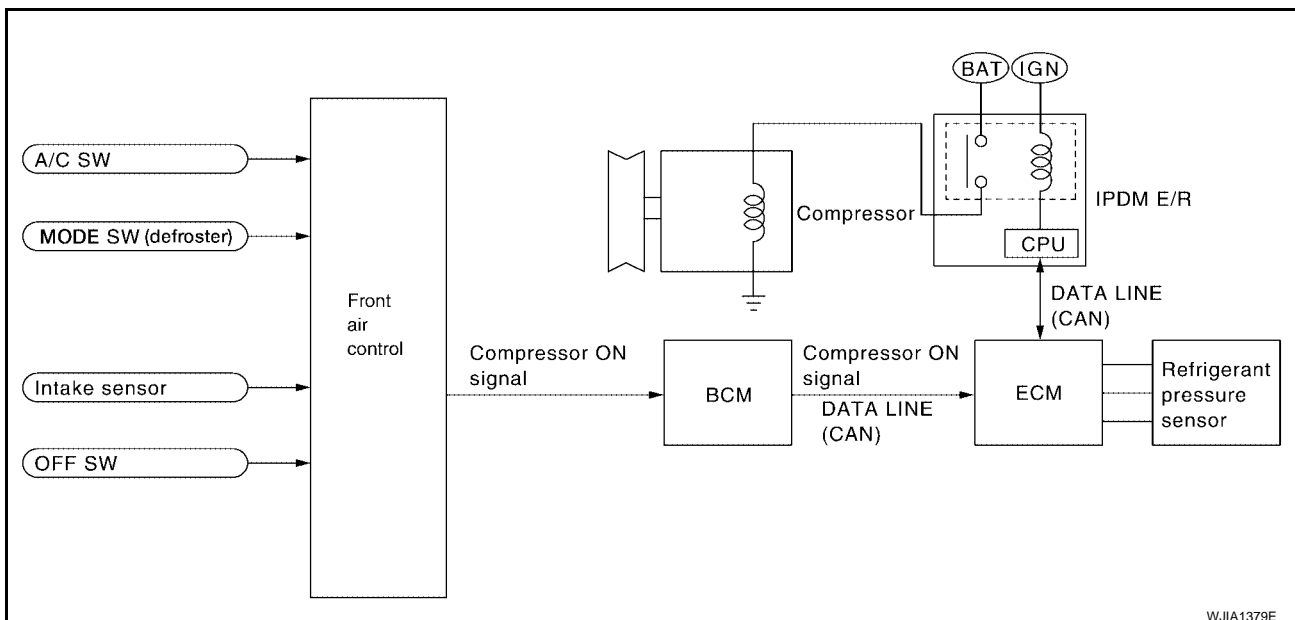

WJJA1379E

When A/C switch or DEF switch is pressed, front air control inputs compressor ON signal to BCM. BCM sends compressor ON signal to ECM, via CAN communication line.

# AIR CONDITIONER CONTROL

---

ECM judges whether compressor can be turned ON, based on each sensor status (refrigerant pressure sensor signal, throttle angle sensor, etc.). If it judges compressor can be turned ON, it sends compressor ON signal to IPDM E/R, via CAN communication line.

Upon receipt of compressor ON signal from ECM, IPDM E/R turns air conditioner relay ON to operate compressor.

## SELF-DIAGNOSTIC SYSTEM

The self-diagnostic system is built into the front air control to quickly locate the cause of symptoms. Refer to [MTC-45, "A/C System Self-diagnosis Function \(With NAVI Only\)"](#).

A

B

C

D

E

F

G

H

I

MTC

K

L

M

# AIR CONDITIONER CONTROL

EJS003TP

## Description of Control System

The control system consists of input sensors, switches, the front air control (microcomputer) and outputs. The relationship of these components is shown in the figure below:

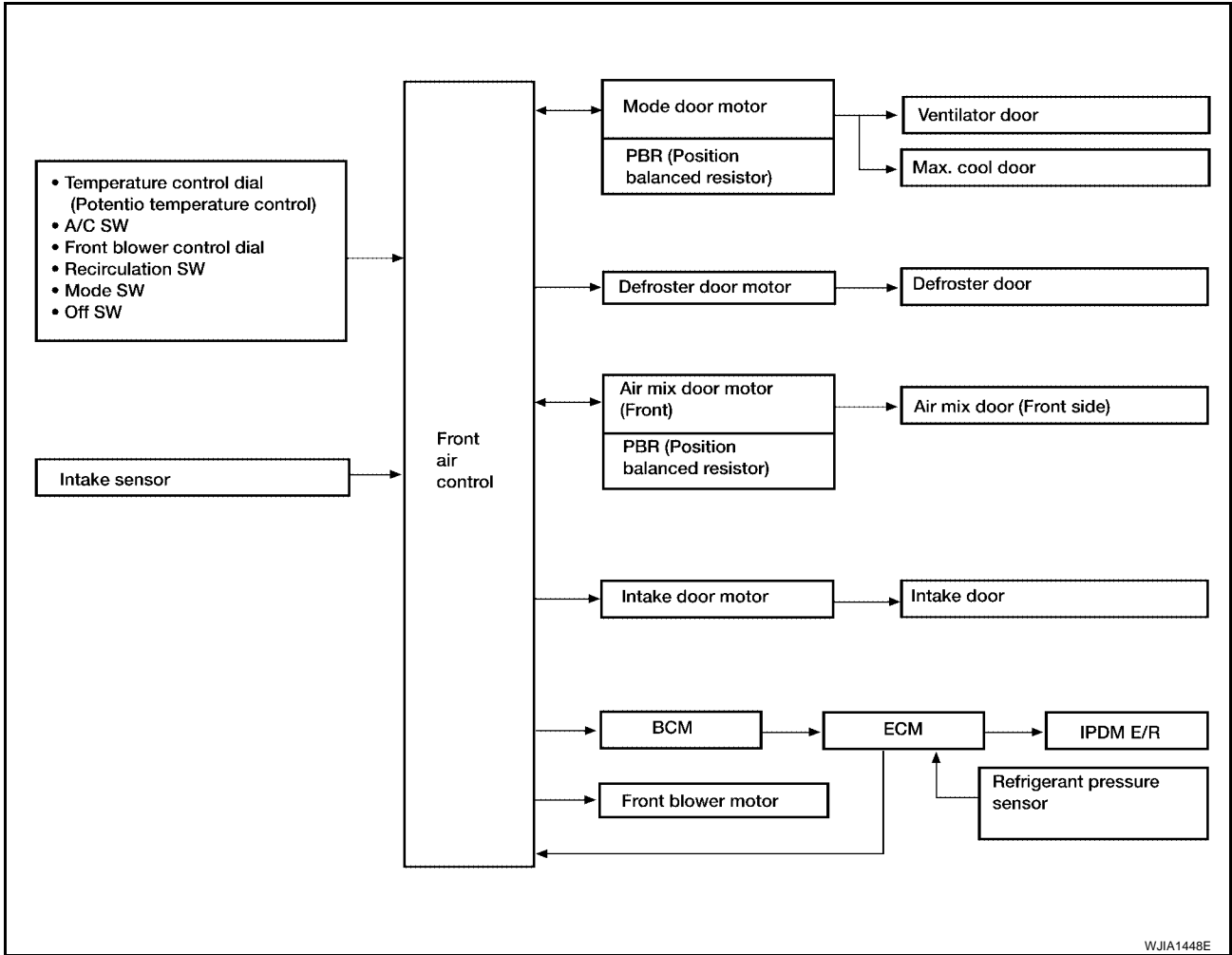

## Control Operation

EJS003TQ

### Front air control

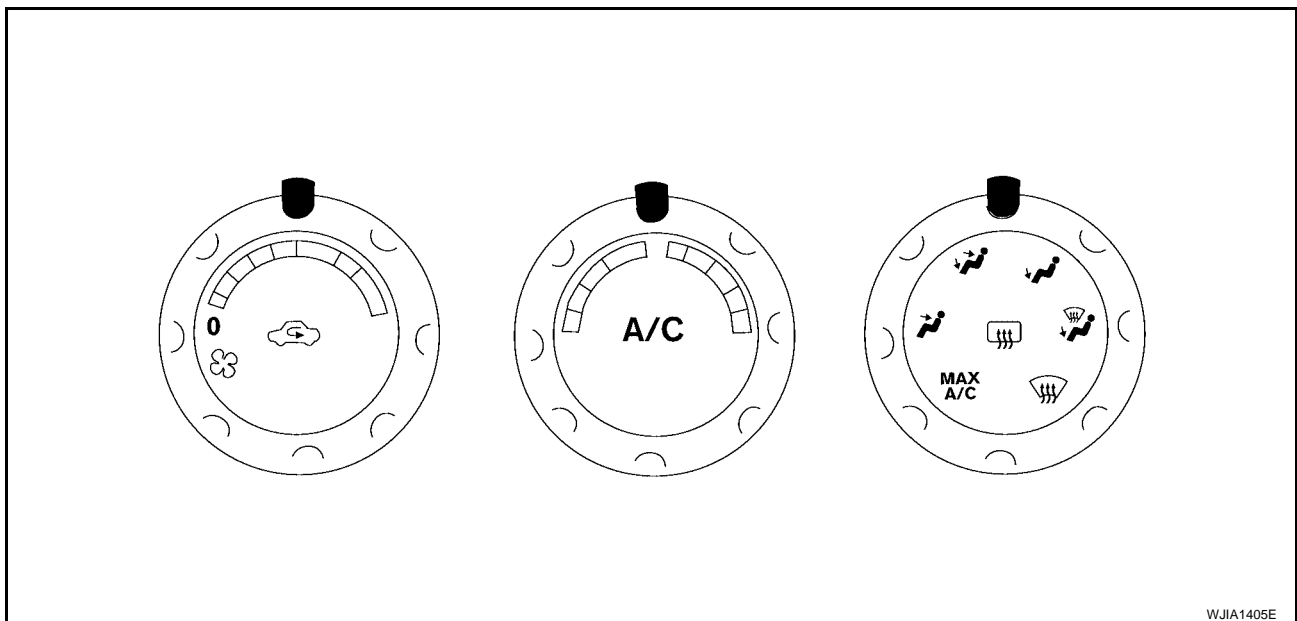



# AIR CONDITIONER CONTROL

## TEMPERATURE CONTROL DIAL (TEMPERATURE CONTROL)

Increases or decreases the set temperature.

### RECIRCULATION ( ) SWITCH

- When REC switch is ON, REC switch indicator turns ON, and air inlet is set to REC.
- When REC switch is turned OFF, or when compressor is turned from ON to OFF, REC switch is automatically turned OFF. REC mode can be re-entered by pressing REC switch again.
- REC switch is not operated when DEF switch is turned ON, at the D/F position, or in floor mode.

### REAR WINDOW DEFOGGER SWITCH

When switch is ON, rear window is defogged.

### OFF SWITCH (BLOWER SPEED SET TO 0)

The compressor and blower are OFF, the intake doors are set to the outside air position, and the air outlet doors are set to the foot position.

### A/C SWITCH

The compressor is ON or OFF.

### MODE CONTROL DIAL

Controls the air discharge outlets through control of the mode and defroster doors.

### FRONT BLOWER CONTROL DIAL



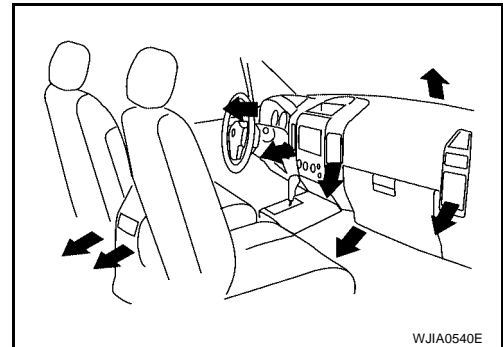

Manually control the blower speed. Fourteen speeds are available for manual control.

## Discharge Air Flow

EJS003TR



### Discharge air flow

Mode door position	Air outlet/distribution		
	Vent	Foot	Defroster
	100%	–	–
	50%	50%	–
	–	(100%)	–
	–	60%	40%
	–	–	100%

WJIA1297E

A  
B  
C  
D  
E  
F  
G  
H  
I

MTC

K  
L  
M

# AIR CONDITIONER CONTROL

EJS003TS

## System Description SWITCHES AND THEIR CONTROL FUNCTION

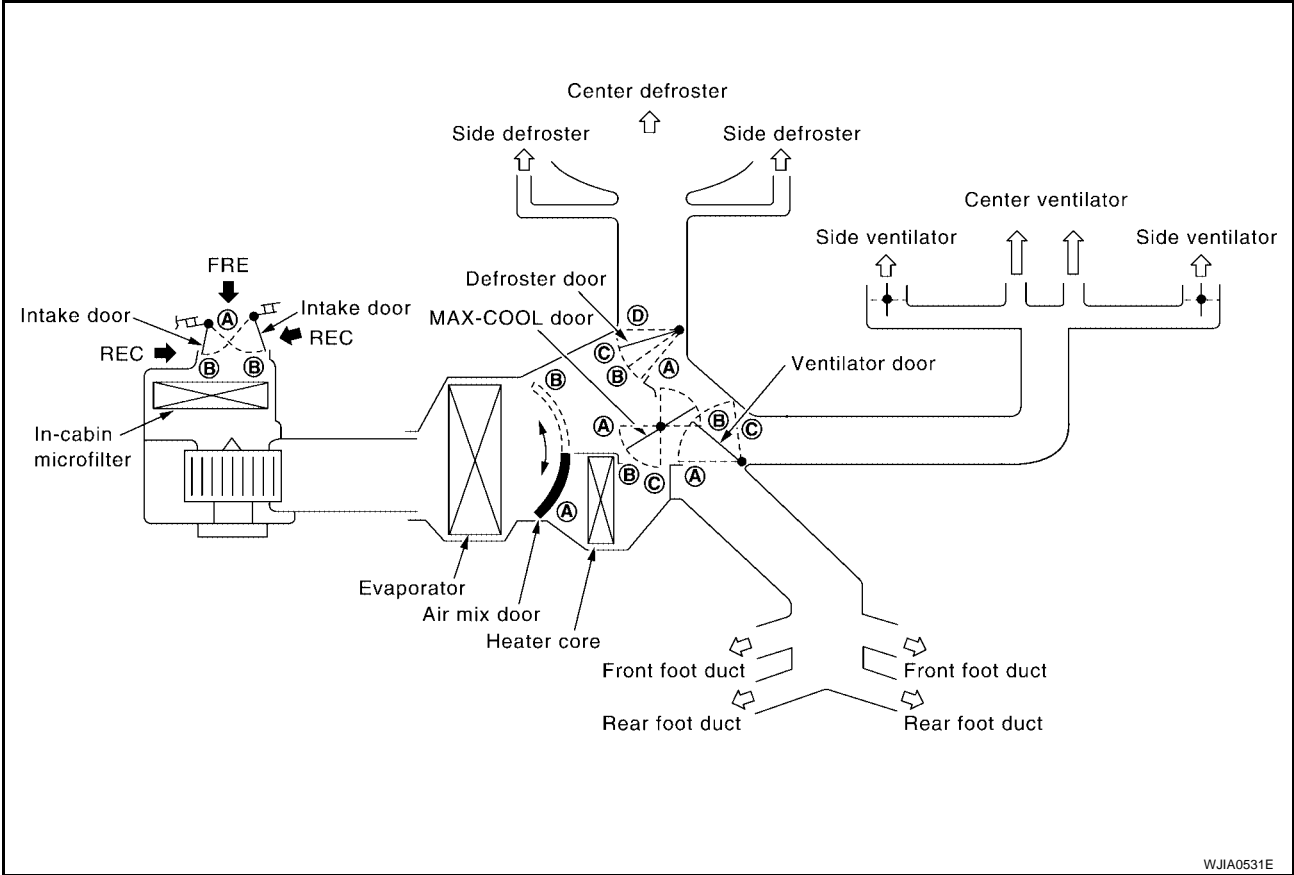

WJIA0531E

Position or switch	MODE SW				DEF SW		REC SW		Temperature switch			OFF SW
	VENT	B/L	FOOT	D/F	ON	OFF	ON	OFF				
Ventilator door	(A)	(B)	(C)	(C)	(C)		---	---	---	---	(C)	
MAX-COOL door	(A)	(B)	(B)	(B)	(C)		---	---	---	---	(B)	
Defroster door	(D)	(D)	(D <sub>or</sub> C)	(B)	(A)		---	---	---	---	(C)	
Intake door	---				(B)		(A)	(B)	---	---	(B)	
Air mix door	---				---		(A)	(B)	---	---	---	

WJIA1406E

# AIR CONDITIONER CONTROL

## CAN Communication System Description

EJS003TU

Refer to [LAN-7, "CAN COMMUNICATION"](#).

A

B

C

D

E

F

G

H

I

MTC

K

L

M

# TROUBLE DIAGNOSIS

## TROUBLE DIAGNOSIS

PF0:0004

### CONSULT-II Function (HVAC)

EJS003TV

CONSULT-II can display each diagnostic item using the diagnostic test modes shown following.

Diagnostic mode	Description
SELF-DIAG RESULTS	Displays front air control self-diagnosis results.
DATA MONITOR	Displays front air control input/output data in real time.
CAN DIAG SUPPORT MNTR	The result of transmit/receive diagnosis of CAN communication can be read.
ECU PART NUMBER	Front air control part number can be read.

### CONSULT-II BASIC OPERATION

#### CAUTION:

If CONSULT-II is used with no connection of CONSULT-II CONVERTER, malfunctions might be detected in self-diagnosis depending on control unit which carries out CAN communication.

1. With the ignition switch OFF, connect CONSULT-II and CONSULT-II CONVERTER to the data link connector, and turn the ignition switch ON.

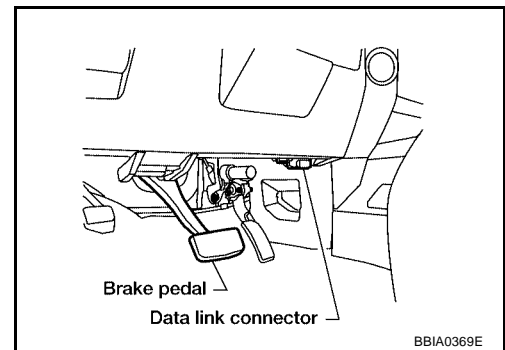

2. Touch "START (NISSAN BASED VHCL)".

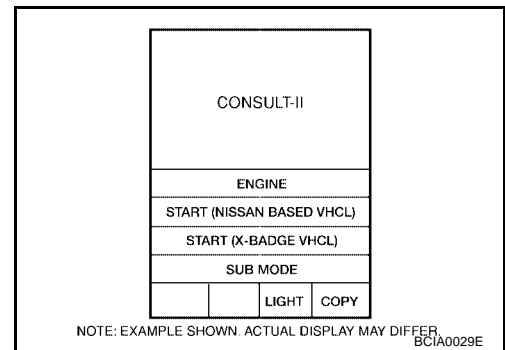

3. Touch "HVAC" on "SELECT SYSTEM" screen. If "HVAC" is not indicated, go to [GI-38, "CONSULT-II Data Link Connector \(DLC\) Circuit"](#).

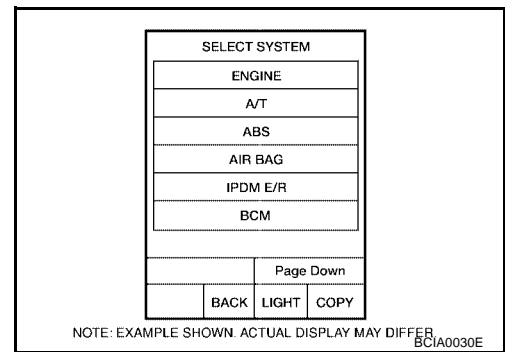

# TROUBLE DIAGNOSIS

## SELF-DIAGNOSIS

### Operation Procedure

1. Touch "SELF-DIAG RESULTS" on "SELECT DIAG MODE" screen to view all set DTC's.

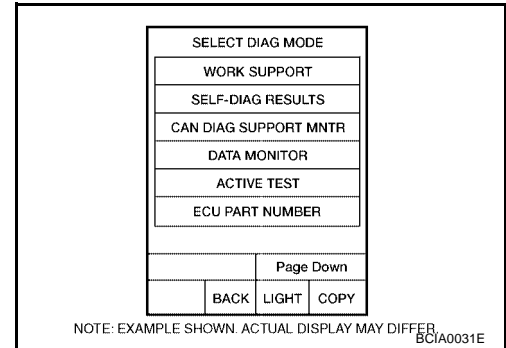

### Display Item List

DTC	Description	Reference page
B2573	Battery voltage out of range	<a href="#">SC-4, "BATTERY"</a>
B2575	BCM not responding to A/C request	<a href="#">MTC-75, "DIAGNOSTIC PROCEDURE FOR MAGNET CLUTCH"</a>
B2576	BCM not responding to rear defroster request	<a href="#">GW-95, "REAR WINDOW DEFOGGER"</a>
B2577	Air mix door motor (Front) circuit failure	<a href="#">MTC-58, "DIAGNOSTIC PROCEDURE FOR AIR MIX DOOR MOTOR (FRONT)"</a>
B2581	Intake sensor circuit short	<a href="#">MTC-60, "Intake Door Motor Circuit"</a>
B2582	Intake sensor circuit open	
B2583	Defroster door motor circuit failure	<a href="#">MTC-63, "Defroster Door Motor Circuit"</a>
U1000	CAN bus fault	<a href="#">LAN-7, "CAN COMMUNICATION"</a>
B2586	Intake door motor (front) circuit malfunction	<a href="#">MTC-60, "Intake Door Motor Circuit"</a>
B2587	Stuck button	<a href="#">MTC-95, "CONTROL UNIT"</a>
B2588	Mode door motor circuit failure	<a href="#">MTC-52, "Mode Door Motor Circuit"</a>

## DATA MONITOR

### Operation Procedure

1. Touch "DATA MONITOR" on "SELECT DIAG MODE" screen.

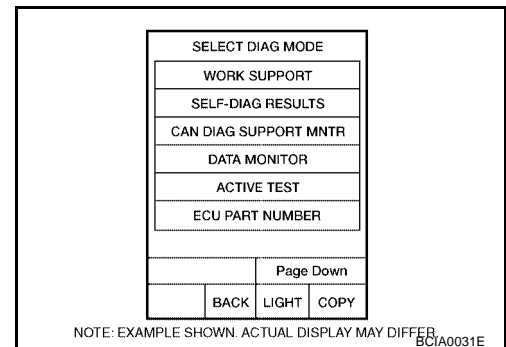

2. Touch either "MAIN SIGNALS" or "SELECTION FROM MENU" on "DATA MONITOR" screen.

All signals	Monitors all the items.
Selection from menu	Selects and monitors the individual item selected.

3. When "SELECTION FROM MENU" is selected, touch items to be monitored. When "MAIN SIGNALS" is selected, all the items will be monitored.
4. Touch "START".

## TROUBLE DIAGNOSIS

5. Touch "RECORD" while monitoring, then the status of the monitored item can be recorded. To stop recording, touch "STOP".

### Display Item List

Monitor item	Value	Contents
BATT VIA CAN	"V"	Displays battery voltage signal.
IGN VIA CAN	"ON/OFF"	Displays ignition switch signal.
EVAP TEMP SEN	"°C/°F"	Displays intake sensor signal.
RR TEMPSET FR	"V"	Displays air mix door (front) set point signal.
MODE FDBCK	"V"	Displays mode door motor feedback signal.
DVR MIX FDBCK	"V"	Displays air mix door motor (front) feedback signal.
DEF FDBCK	"V"	Displays defroster door motor feedback signal.
RECIRC	"ON/OFF"	Displays recirculation switch signal.
A/C	"ON/OFF"	Displays A/C switch signal.
RR DEFOG	"ON/OFF"	Displays rear defroster request signal.
MODE SELECT	" [ PNL ]" " [ MIX ]" " [ FLR ]" " [ DEFR ]" " [ MAX ]" " [ DENT ]"	Displays mode door motor position.

\*: DENT is displayed when MODE switch is between selections.

# TROUBLE DIAGNOSIS

## CONSULT-II Function (BCM)

EJS003TW

CONSULT-II can display each diagnostic item using the diagnostic test modes shown following.

BCM diagnostic test item	Diagnostic mode	Description
Inspection by part	WORK SUPPORT	Supports inspections and adjustments. Commands are transmitted to the BCM for setting the status suitable for required operation, input/output signals are received from the BCM and received data is displayed.
	DATA MONITOR	Displays BCM input/output data in real time.
	ACTIVE TEST	Operation of electrical loads can be checked by sending drive signal to them.
	SELF-DIAG RESULTS	Displays BCM self-diagnosis results.
	CAN DIAG SUPPORT MNTR	The result of transmit/receive diagnosis of CAN communication can be read.
	ECU PART NUMBER	BCM part number can be read.
	CONFIGURATION	Performs BCM configuration read/write functions.

## CONSULT-II BASIC OPERATION

### CAUTION:

If CONSULT-II is used with no connection of CONSULT-II CONVERTER, malfunctions might be detected in self-diagnosis depending on control unit which carries out CAN communication.

1. With the ignition switch OFF, connect CONSULT-II and CONSULT-II CONVERTER to the data link connector, and turn the ignition switch ON.

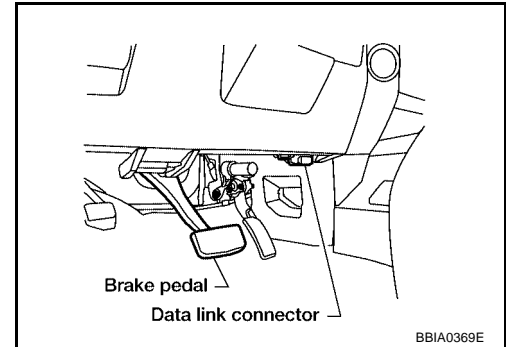

2. Touch "START (NISSAN BASED VHCL)".

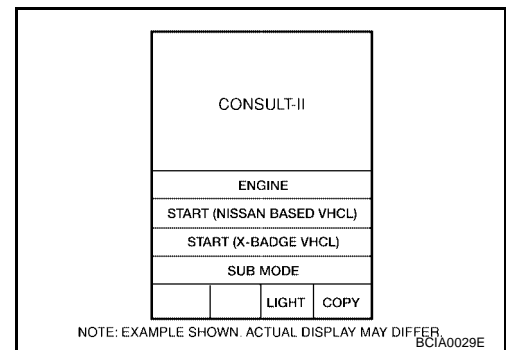

3. Touch "BCM" on "SELECT SYSTEM" screen. If "BCM" is not indicated, go to [GI-38, "CONSULT-II Data Link Connector \(DLC\) Circuit"](#).

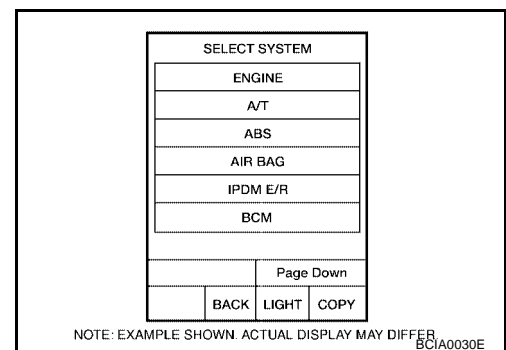

# TROUBLE DIAGNOSIS

## DATA MONITOR

### Operation Procedure

1. Touch "AIR CONDITIONER" on "SELECT TEST ITEM" screen.

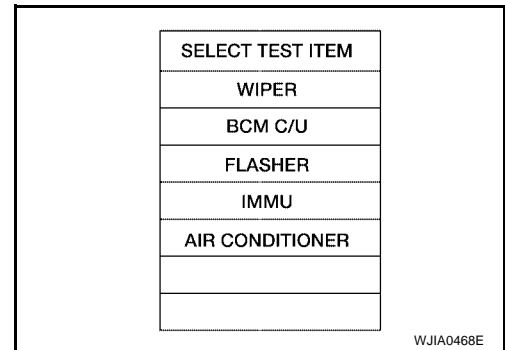

2. Touch "DATA MONITOR" on "SELECT DIAG MODE" screen.

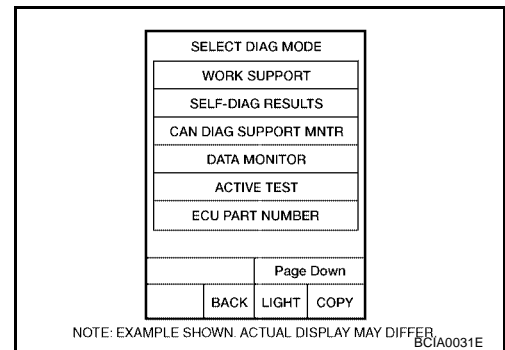

3. Touch either "ALL SIGNALS" or "SELECTION FROM MENU" on "DATA MONITOR" screen.

All Signals	Monitors all the items.
Selection from menu	Selects and monitors the individual item selected.

4. When "SELECTION FROM MENU" is selected, touch items to be monitored. When "ALL SIGNALS" is selected, all the items will be monitored.

5. Touch "START".

6. Touch "RECORD" while monitoring, then the status of the monitored item can be recorded. To stop recording, touch "STOP".

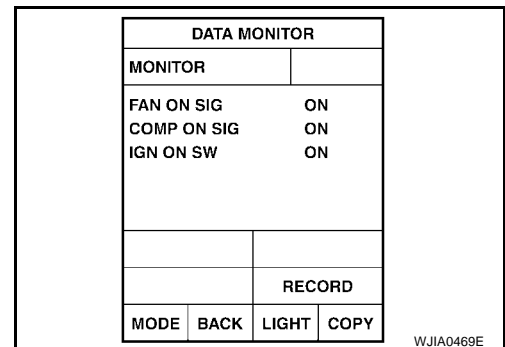

### Display Item List

Monitor item name "operation or unit"	Contents
IGN ON SW "ON/OFF"	Displays "IGN Position (ON)/(OFF), ACC Position (OFF)" status as judged from ignition switch signal.
COMP ON SIG "ON/OFF"	Displays "COMP (ON)/COMP (OFF)" status as judged from air conditioner switch signal.
FAN ON SIG "ON/OFF"	Displays "FAN (ON)/FAN (OFF)" status as judged from blower motor switch signal.



# TROUBLE DIAGNOSIS

## How to Perform Trouble Diagnosis for Quick and Accurate Repair WORK FLOW

EJS003TX

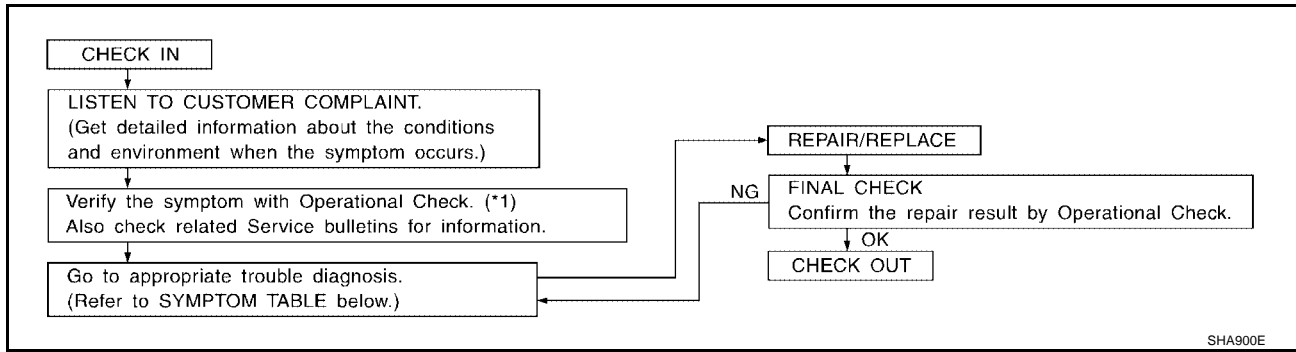

\*1 [MTC-47. "Operational Check"](#).

### SYMPTOM TABLE

Symptom	Reference Page	
A/C system does not come on.	Go to Trouble Diagnosis Procedure for A/C System.	<a href="#">MTC-49</a>
A/C system cannot be controlled.	Go to Self-diagnosis Function.	<a href="#">MTC-45</a>
Air outlet does not change.	Go to Trouble Diagnosis Procedure for Mode Door Motor.	<a href="#">MTC-52</a>
Mode door motor is malfunctioning.		
Discharge air temperature does not change.	Go to Trouble Diagnosis Procedure for Air Mix Door Motor.	<a href="#">MTC-56</a>
Air mix door motor is malfunctioning.		
Intake door does not change.	Go to Trouble Diagnosis Procedure for Intake Door Motor.	<a href="#">MTC-60</a>
Intake door motor is malfunctioning.		
Defroster door motor is malfunctioning.	Go to Trouble Diagnosis Procedure for Defroster Door Motor.	<a href="#">MTC-63</a>
Front blower motor operation is malfunctioning.	Go to Trouble Diagnosis Procedure for Front Blower Motor.	<a href="#">MTC-67</a>
Magnet clutch does not engage.	Go to Trouble Diagnosis Procedure for Magnet Clutch.	<a href="#">MTC-74</a>
Insufficient cooling	Go to Trouble Diagnosis Procedure for Insufficient Cooling.	<a href="#">MTC-80</a>
Insufficient heating	Go to Trouble Diagnosis Procedure for Insufficient Heating.	<a href="#">MTC-87</a>
Noise	Go to Trouble Diagnosis Procedure for Noise.	<a href="#">MTC-88</a>
Self-diagnosis cannot be performed.	Go to Trouble Diagnosis Procedure for Self-diagnosis.	<a href="#">MTC-89</a>

# TROUBLE DIAGNOSIS

## Component Parts and Harness Connector Location ENGINE COMPARTMENT

EJS003TY

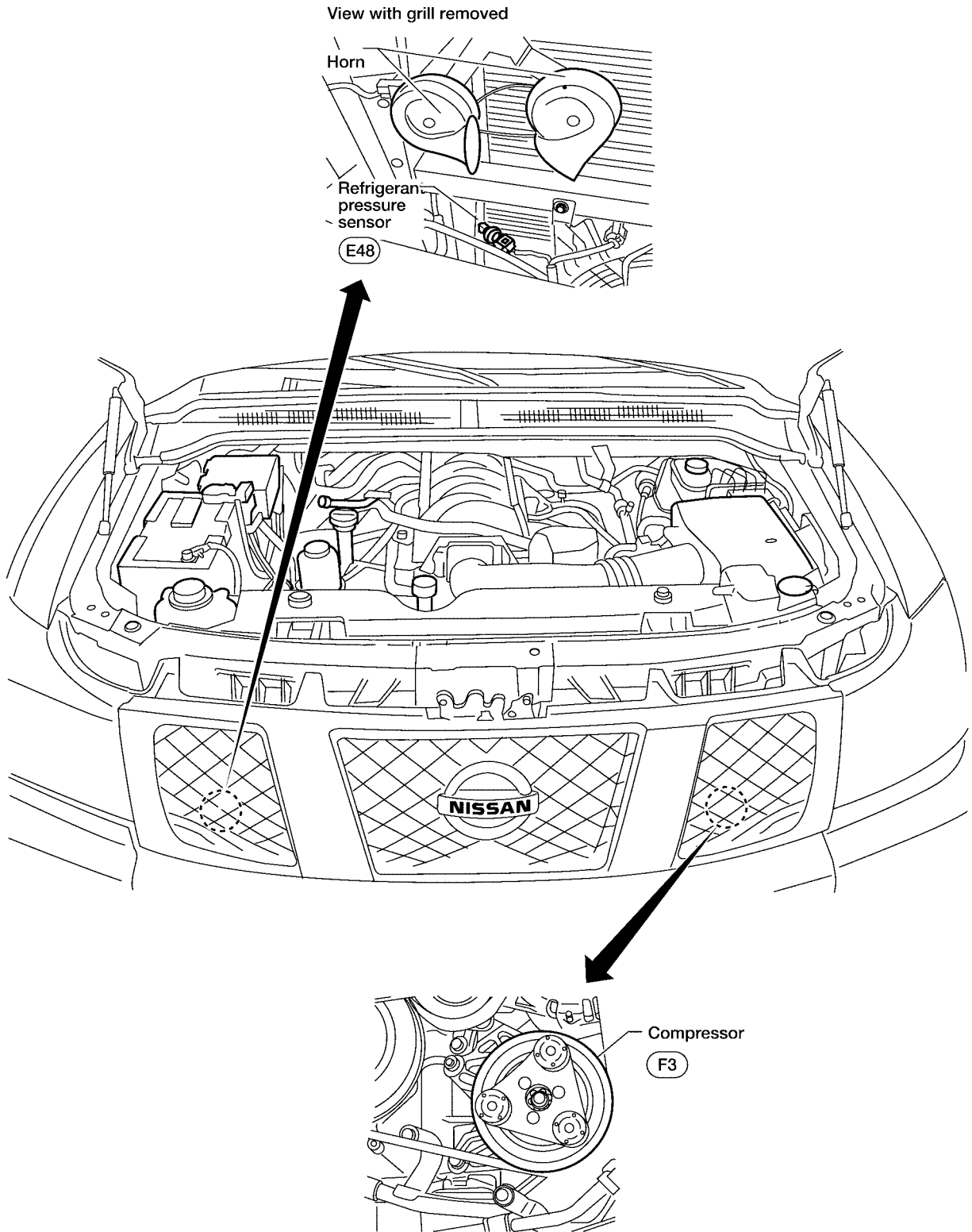

WJIA1407E

# TROUBLE DIAGNOSIS

## FRONT PASSENGER COMPARTMENT

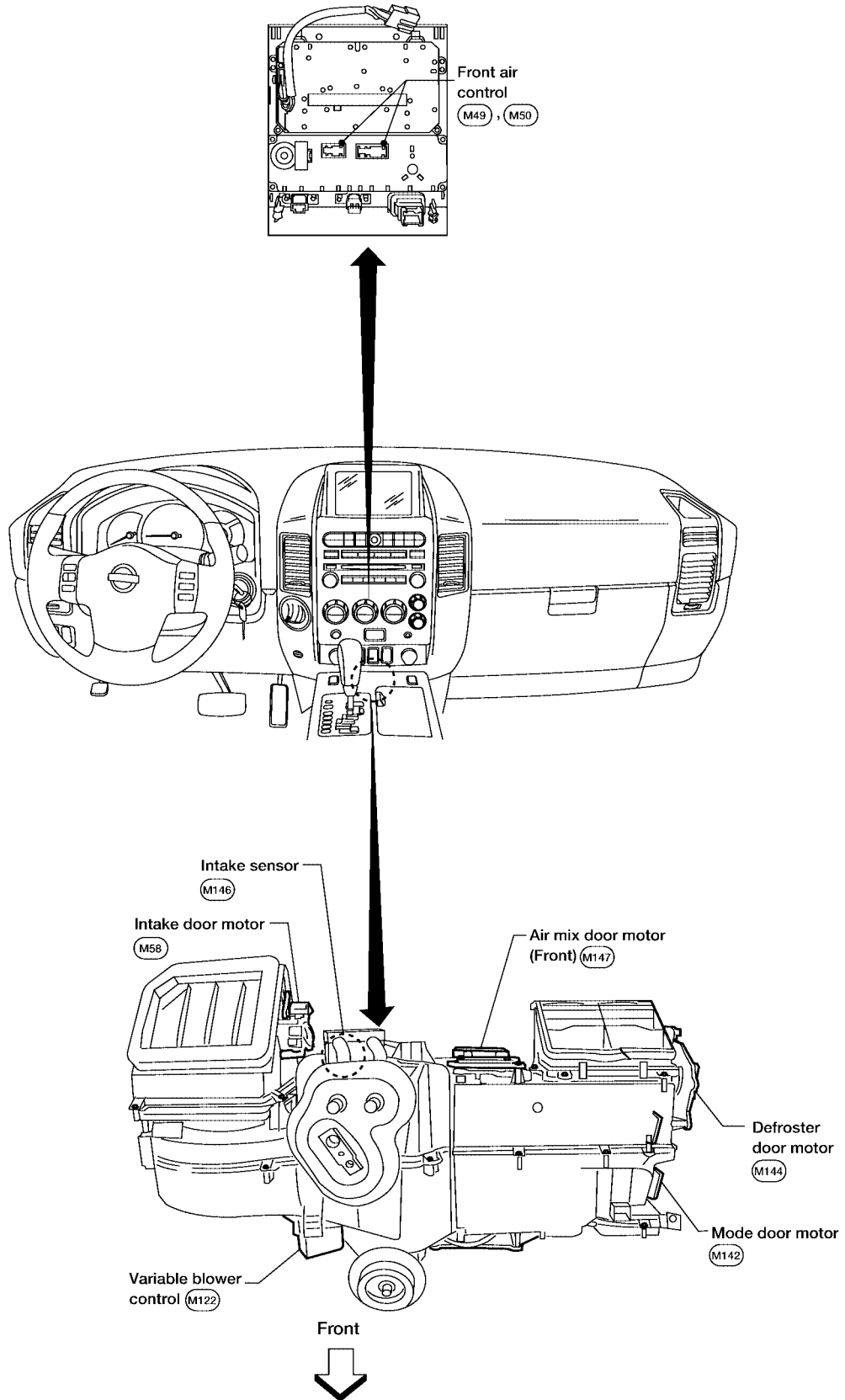

A

B

C

D

E

F

G

H

I

MTC

K

L

M

WJIA1449E

# TROUBLE DIAGNOSIS

## Schematic

EJS003TZ

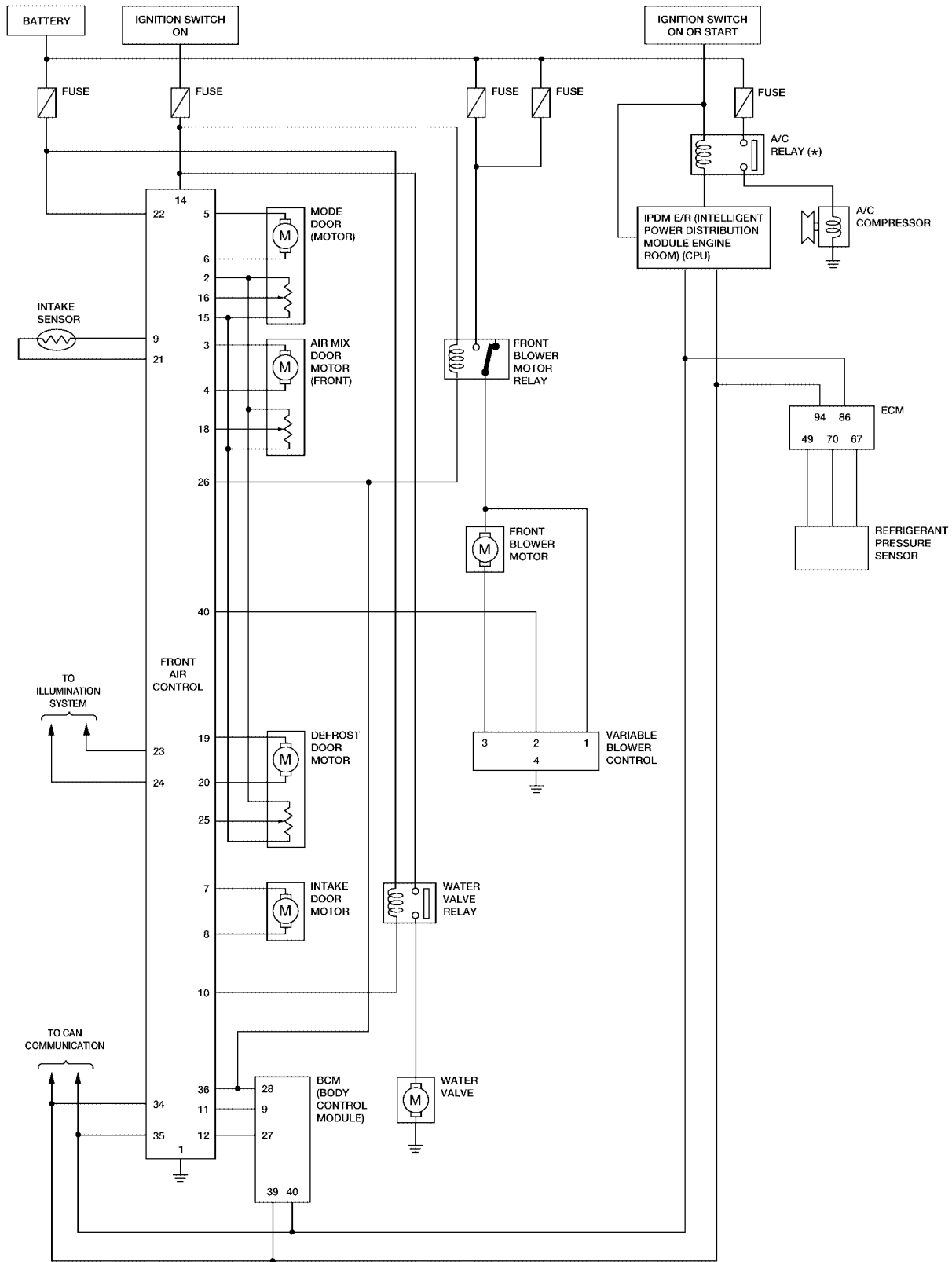

\*: THIS RELAY IS BUILT INTO THE IPDM E/R  
(INTELLIGENT POWER DISTRIBUTION MODULE ENGINE ROOM)

WJWA0217E

# TROUBLE DIAGNOSIS

## Wiring Diagram — A/C —

EJS003U0

MTC-A/C,M-01

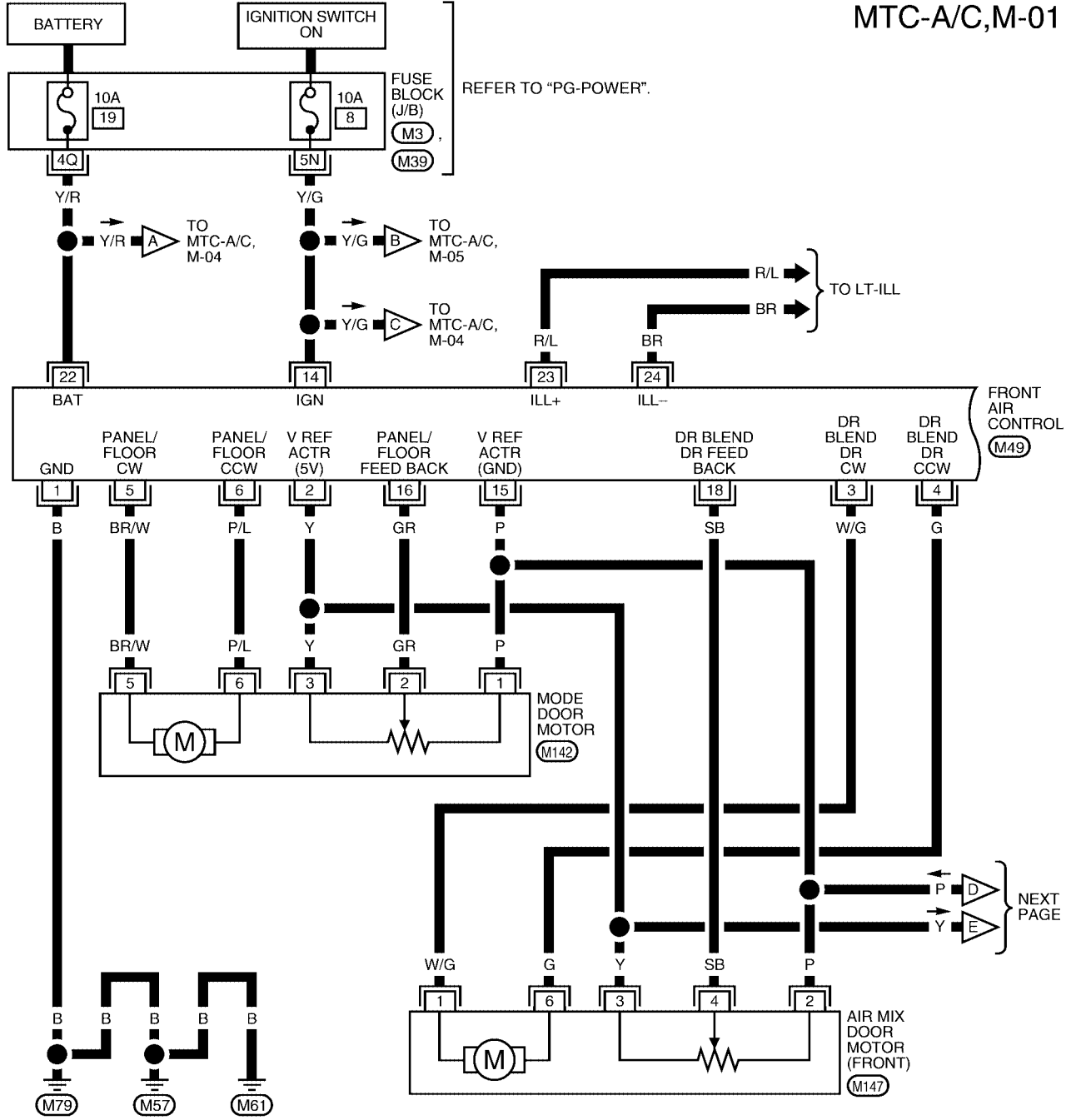

A  
B  
C  
D  
E  
F  
G  
H  
I  
J  
K  
L  
M

MTC

NEXT PAGE

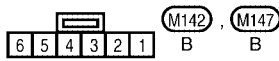
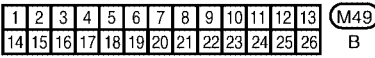
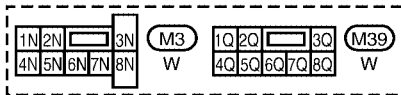

WJWA0218E

# TROUBLE DIAGNOSIS

MTC-A/C, M-02

▬ : DATA LINE

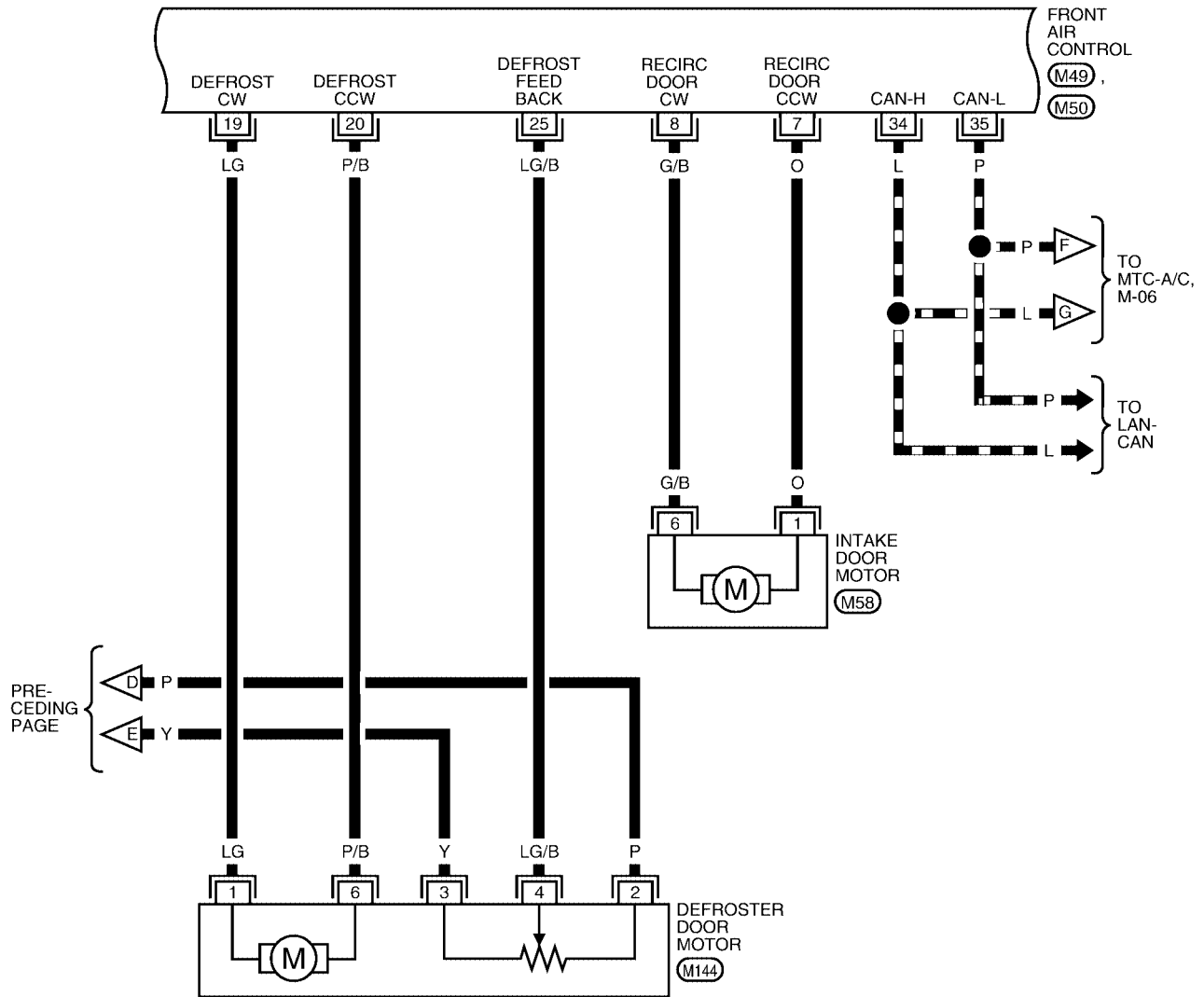

1	2	3	4	5	6	7	8	9	10	11	12	13	(M49)	27	28	29	30	31	32	33	34	35	(M50)
14	15	16	17	18	19	20	21	22	23	24	25	26	B	36	37	38	39	40	41	42	43	44	W

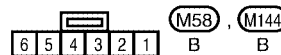

WJWA0219E

# TROUBLE DIAGNOSIS

MTC-A/C,M-03

A  
B  
C  
D  
E  
F  
G  
H  
I  
MTC  
K  
L  
M

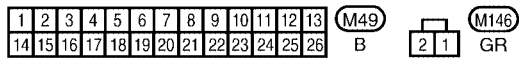
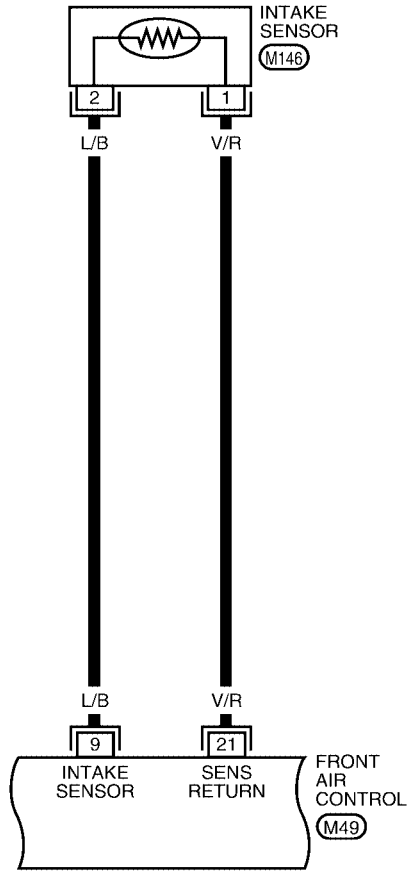

WJWA0220E

# TROUBLE DIAGNOSIS

MTC-A/C,M-04

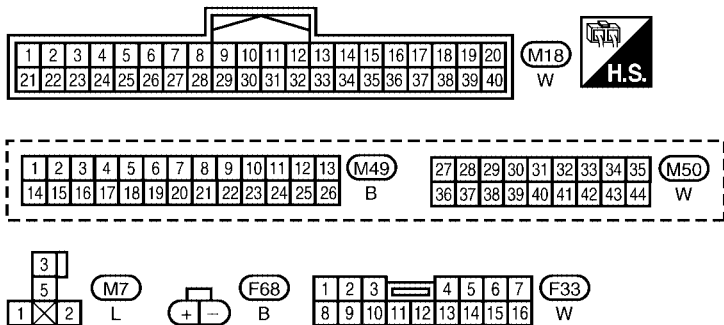
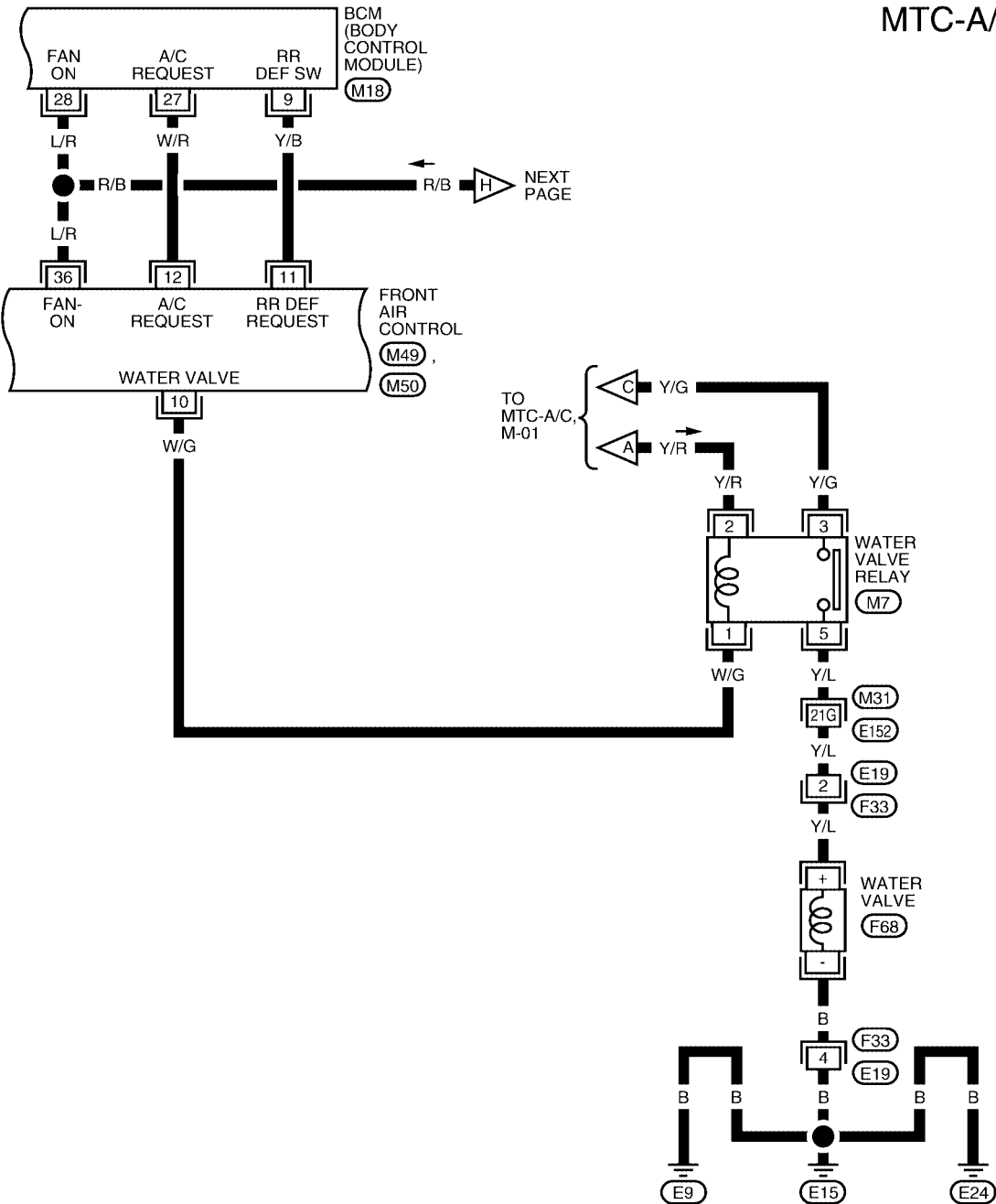

REFER TO THE FOLLOWING.  
 (M31) - SUPER MULTIPLE JUNCTION (SMJ)

WJWA0221E



# TROUBLE DIAGNOSIS

MTC-A/C, M-05

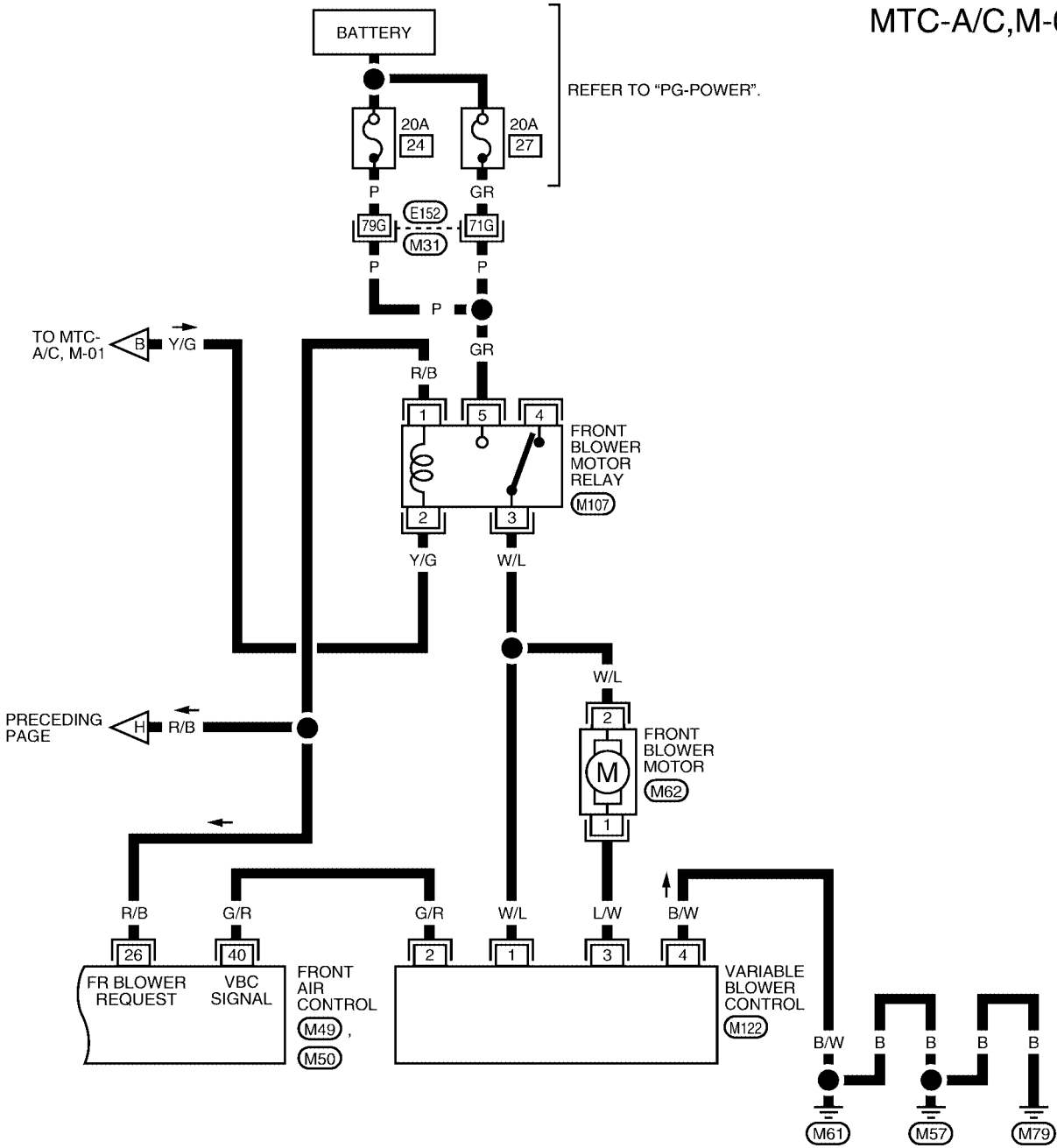

A  
B  
C  
D  
E  
F  
G  
H  
I  
MTC  
K  
L  
M

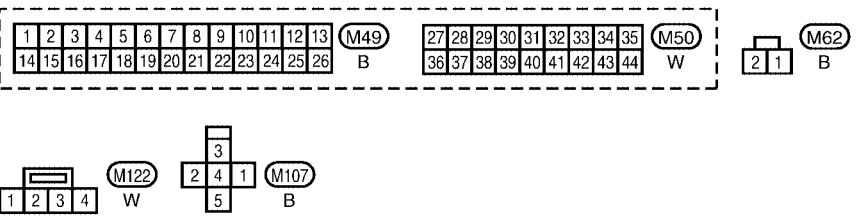

REFER TO THE FOLLOWING.  
M31 - SUPER MULTIPLE JUNCTION (SMJ)

WJWA0222E

# TROUBLE DIAGNOSIS

## MTC-A/C, M-06

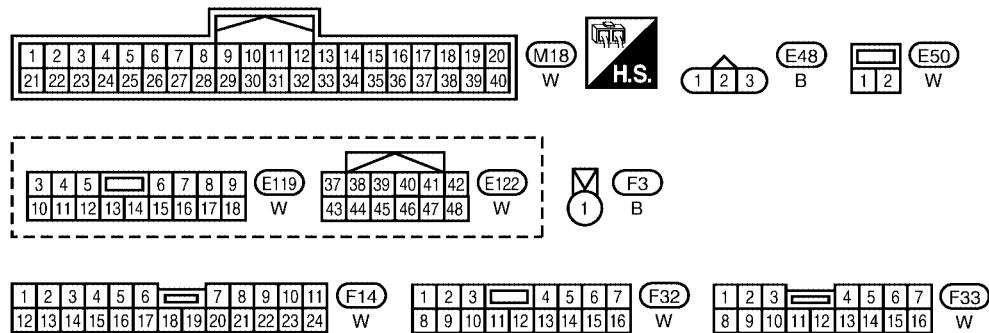
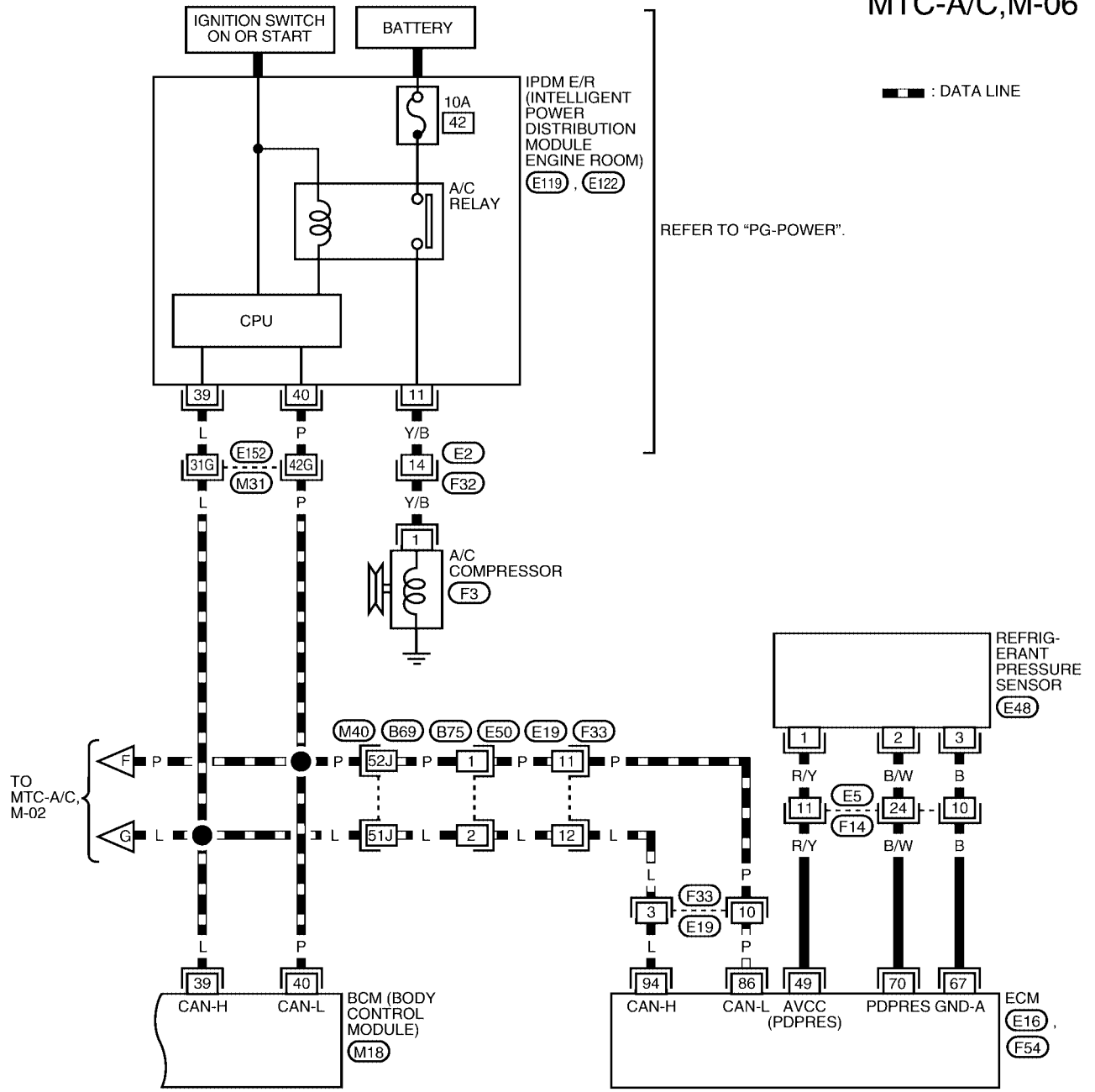

REFER TO THE FOLLOWING.  
 (E16), (F54) - ELECTRICAL UNITS  
 (M31), (M40) - SUPER MULTIPLE JUNCTION (SMJ)

WJWA0223E

# TROUBLE DIAGNOSIS

EJS003U1

## Front Air Control Terminals and Reference Value

Measure voltage between each terminal and ground by following Terminals and Reference Value for front air control.

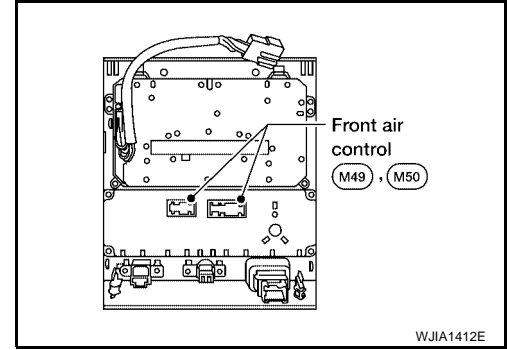

### PIN CONNECTOR TERMINAL LAYOUT

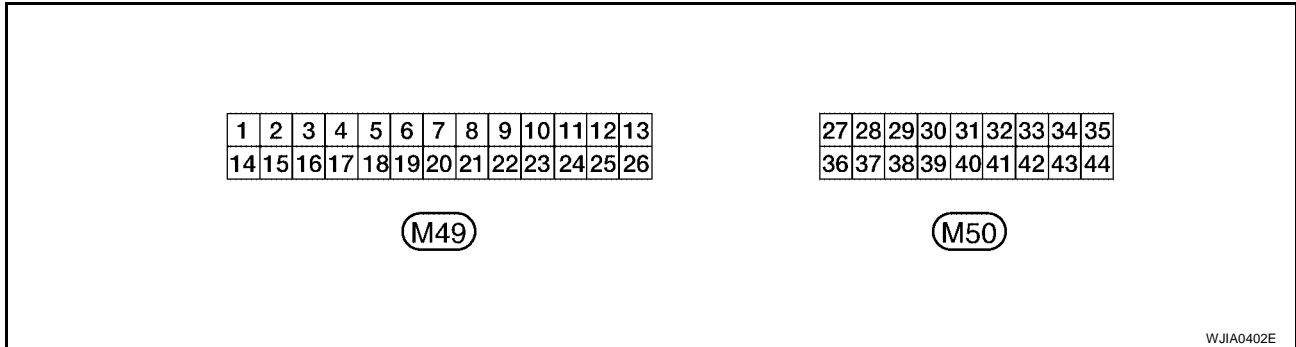

### TERMINALS AND REFERENCE VALUE FOR FRONT AIR CONTROL

Terminal No.	Wire color	Item	Ignition switch	Condition	Voltage (V) (Approx.)
1	B	Ground	-	-	0V
2	Y	Sensor power	ON	-	5V
3	W/G	Air mix door motor (Front) CW	ON	Clockwise rotation	Battery voltage
4	G	Air mix door motor (Front) CCW	ON	Counterclockwise rotation	Battery voltage
5	BR/W	Mode door motor CW	ON	Clockwise rotation	Battery voltage
6	P/L	Mode door motor CCW	ON	Counterclockwise rotation	Battery voltage
7	O	Intake door motor CCW	ON	Counterclockwise rotation	Battery voltage
8	G/B	Intake door motor CW	ON	Clockwise rotation	Battery voltage
9	L/B	Intake sensor	ON	-	0 - 5V
10	W/G	Water valve	ON	Water valve open	0V
			ON	Water valve closed	5V
11	Y/B	Rear defroster request	ON	-	Battery voltage
12	W/R	Compressor ON signal	ON	A/C switch OFF	5V
			ON	A/C switch ON	0V
14	Y/G	Power supply for IGN	ON	-	Battery voltage
15	P	Sensor ground	ON	-	0V
16	GR	Mode door motor feedback	ON	-	0 - 5V
18	SB	Air mix door motor (Front) feedback	ON	-	0 - 5V
19	LG	Defroster door motor CW	ON	Clockwise rotation	Battery voltage
20	P/B	Defroster door motor CCW	ON	Counterclockwise rotation	Battery voltage
21	V/R	Sensor return	ON	-	0 - 5V
22	Y/R	Power supply for BAT	-	-	Battery voltage
23	R/L	Illumination +	ON	Park lamps ON	Battery voltage

A  
B  
C  
D  
E  
F  
G  
H  
I  
M

MTC

# TROUBLE DIAGNOSIS

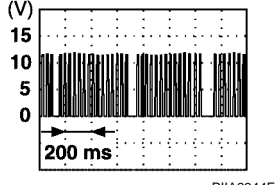
Terminal No.	Wire color	Item	Ignition switch	Condition	Voltage (V) (Approx.)
24	BR	Illumination -	-	Park lamps ON	
25	LG/B	Defroster door motor feedback	ON	-	0 - 5V
26	R/B	Front blower request	ON	Front blower motor OFF	Battery voltage
				Front blower motor ON	0V
34	L	CAN-H	ON	-	0 - 5V
35	P	CAN-L	ON	-	0 - 5V
36	L/R	Fan ON signal	ON	Fan switch OFF	5V
				Fan switch ON	0V
40	G/R	Variable Blower Control output	ON	-	0 - 5V

# TROUBLE DIAGNOSIS

EJS003U2

## A/C System Self-diagnosis Function (With NAVI Only) DESCRIPTION

The self-diagnostic system diagnoses sensors, door motors, blower motor, etc. Refer to applicable sections (items) for details. Fault codes (if any are present) will be displayed in the ambient temperature display area. Refer to [MTC-46, "SELF-DIAGNOSIS CODE CHART"](#).

Ignition must be on to run self test.  
Self test must be run at an ambient of at least 10 degrees C.

### Self Test Via Center Switch w/navi Unit (color display)

1. On the audio/navi switches, hold the "Pause/Mute" button and twist the audio "Power/Volume" knob until the Self Diagnostic screen shows on the display.
2. Scroll down and select "Confirmation/Adjustment" with the joystick.
3. Scroll over and select the "Auto Climate Control" with the joystick to start the self-test.
4. The fan bars will flash on the display during the self-test, and then the fault codes will display in the ambient temperature area. They will continue scrolling until diagnostic mode is exited.
5. Exit by pressing the "Previous" button on audio/navi switches until display returns to its normal operation screen. HVAC system will be off.

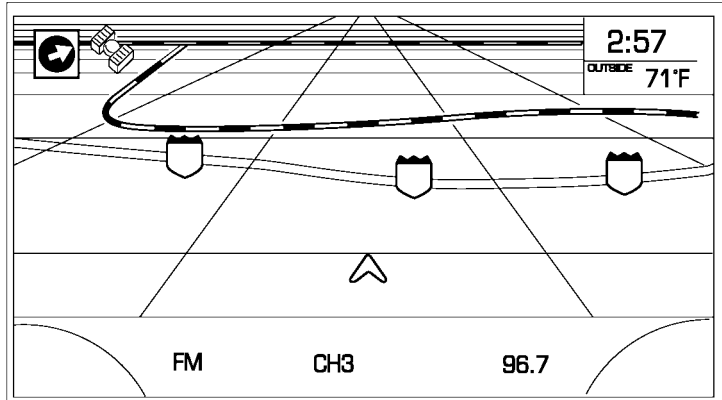

Display screen

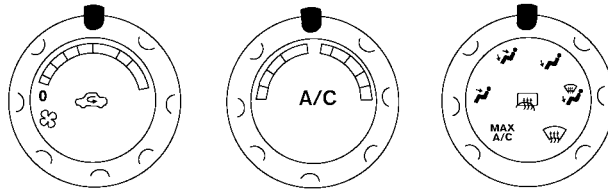

A  
B  
C  
D  
E  
F  
G  
H  
I  
K  
L  
M

MTC

WJIA1414E

# TROUBLE DIAGNOSIS

## SELF-DIAGNOSIS CODE CHART

Code No.		Reference page
03	Battery voltage out of range	<a href="#">SC-4, "BATTERY"</a>
20	BCM not responding to A/C request	<a href="#">MTC-75, "DIAGNOSTIC PROCEDURE FOR MAGNET CLUTCH"</a>
21	BCM not responding to rear defroster request	<a href="#">GW-95, "REAR WINDOW DEFOGGER"</a>
22	Air mix door motor (Front) circuit failure	<a href="#">MTC-56, "Air Mix Door Motor Circuit"</a>
56	Intake sensor circuit short	<a href="#">MTC-92, "Intake Sensor Circuit"</a>
57	Intake sensor circuit open	
62	Defroster door motor circuit failure	<a href="#">MTC-63, "Defroster Door Motor Circuit"</a>
80	CAN bus fault	<a href="#">LAN-7, "CAN COMMUNICATION"</a>
82	Intake door motor (front) circuit malfunction	<a href="#">MTC-62, "DIAGNOSTIC PROCEDURE FOR INTAKE DOOR MOTOR"</a>
90	Stuck button	<a href="#">MTC-95, "CONTROL UNIT"</a>
92	Mode door motor circuit failure	<a href="#">MTC-52, "Mode Door Motor Circuit"</a>

# TROUBLE DIAGNOSIS

EJS003U3

## Operational Check

The purpose of the operational check is to confirm that the system operates properly.

**Conditions : Engine running and at normal operating temperature**

### CHECKING BLOWER

1. Turn fan control switch clockwise. Blower should operate on low speed.
2. Turn the fan control switch again, and continue checking blower speed and fan symbol until all speeds are checked.
3. Leave blower on MAX speed.

If NG, go to [MTC-69, "DIAGNOSTIC PROCEDURE FOR BLOWER MOTOR"](#)

If OK, continue with next check.

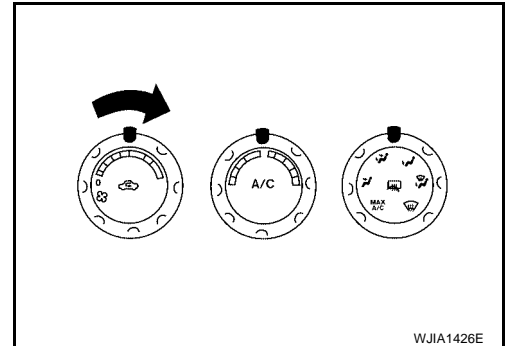

WJIA1426E

### CHECKING DISCHARGE AIR

1. Turn the mode switch to each mode position.

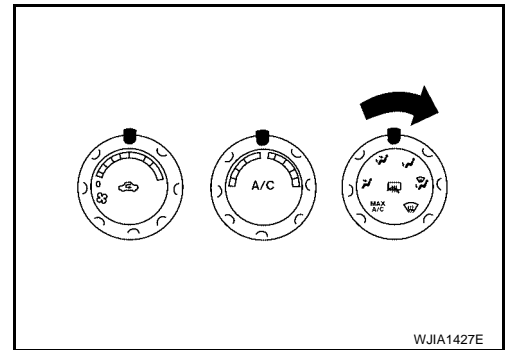

WJIA1427E

2. Confirm that discharge air comes out according to the air distribution table. Refer to [MTC-25, "Discharge Air Flow"](#).

Mode door position is checked in the next step.

If NG, go to trouble diagnosis procedure for [MTC-52, "Mode Door Motor Circuit"](#).

If OK, continue with next check.

#### NOTE:

Confirm that the compressor clutch is engaged (sound or visual inspection) and intake door position is at fresh when the DEF or D/F is selected.

**Discharge air flow**

Mode door position	Air outlet/distribution		
	Vent	Foot	Defroster
	100%	—	—
	50%	50%	—
	—	(100%)	—
	—	60%	40%
	—	—	100%

WJIA1297E

### CHECKING RECIRCULATION

1. Press recirculation ( ) switch one time. Recirculation indicator should illuminate.
2. Press recirculation ( ) switch one more time. Recirculation indicator should go off.
3. Listen for intake door position change (blower sound should change slightly).

If NG, go to trouble diagnosis procedure for [MTC-60, "Intake Door Motor Circuit"](#).

If OK, continue with next check.

#### NOTE:

Confirm that the compressor clutch is engaged (sound or visual inspection) and intake door position is at fresh when the DEF, D/F or floor is selected.

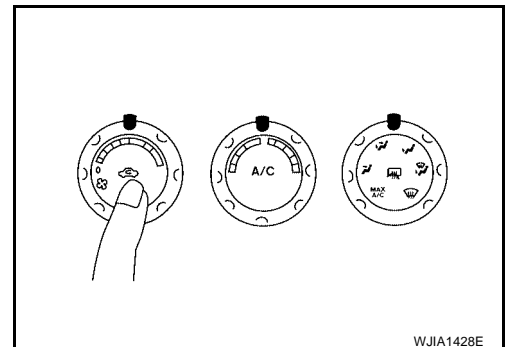

WJIA1428E

A  
B  
C  
D  
E  
F  
G  
H  
I  
MTC  
K  
L  
M

# TROUBLE DIAGNOSIS

## CHECKING TEMPERATURE DECREASE

1. Rotate temperature control dial counterclockwise.
2. Check for cold air at appropriate discharge air outlets.

If NG, listen for sound of air mix door motor operation. If OK, go to trouble diagnosis procedure for [MTC-80, "Insufficient Cooling"](#). If air mix door motor appears to be malfunctioning, go to [MTC-58, "DIAGNOSTIC PROCEDURE FOR AIR MIX DOOR MOTOR \(FRONT\)"](#). If OK, continue with next check.

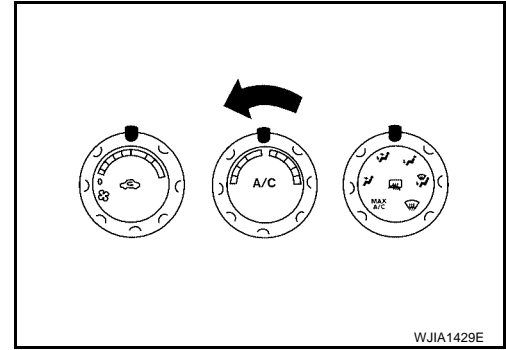

## CHECKING TEMPERATURE INCREASE

1. Rotate temperature control dial clockwise.
2. Check for hot air at appropriate discharge air outlets.

If NG, listen for sound of air mix door motor operation. If OK, go to trouble diagnosis procedure for [MTC-87, "Insufficient Heating"](#). If air mix door motor appears to be malfunctioning, go to [MTC-58, "DIAGNOSTIC PROCEDURE FOR AIR MIX DOOR MOTOR \(FRONT\)"](#). If OK, continue with next check.

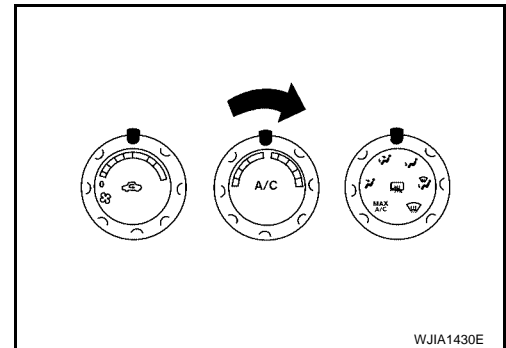

## CHECK A/C SWITCH

1. Press A/C switch with the fan switch ON.
2. A/C switch indicator will turn ON.
  - Confirm that the compressor clutch engages (sound or visual inspection).

### NOTE:

Confirm that the compressor clutch is engaged (sound or visual inspection).

If NG, go to trouble diagnosis procedure for [MTC-74, "Magnet Clutch Circuit"](#).

If OK, continue with next check.

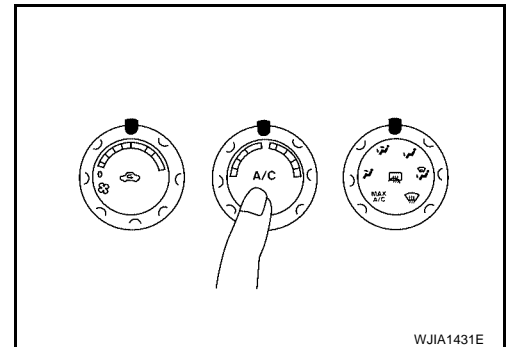



# TROUBLE DIAGNOSIS

EJS003U5

## Power Supply and Ground Circuit for Front Air Control

SYMPTOM: A/C system does not come on.

### INSPECTION FLOW

1. Confirm symptom by performing the following operational check.

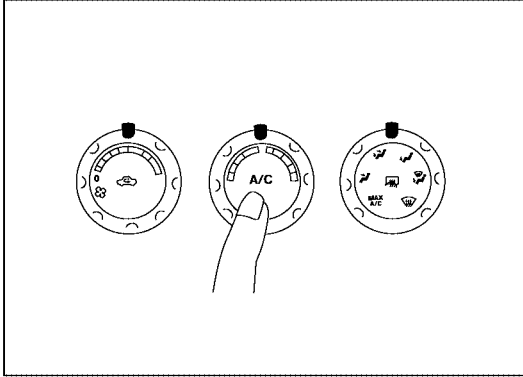

#### OPERATIONAL CHECK –

- Press A/C switch.
- Display should indicate A/C.  
Confirm that the compressor clutch engages (Sound or visual inspection).

**If OK (symptom cannot be duplicated), perform complete operational check (\*2).**  
**If NG (symptom is confirmed), continue with STEP-2 following.**

2. Check for any service bulletins.

3. Check Main Power Supply and Ground Circuit. (\*1)

4. Replace front air control.

\*1 [MTC-49. "Power Supply and Ground Circuit for Front Air Control"](#). \*2 [MTC-47. "Operational Check"](#)

WJJA1411E

MTC

# TROUBLE DIAGNOSIS

## COMPONENT DESCRIPTION

### Front Air Control

The front air control has a built-in microcomputer which processes information sent from various sensors needed for air conditioner operation. The air mix door motor, mode door motor, intake door motor, defroster door motor, blower motor and compressor are then controlled.

The front air control is unitized with control mechanisms. When the various switches and temperature dial are operated, data is input to the front air control.

Self-diagnostic functions are also built into the front air control to provide quick check of malfunctions in the air conditioner system.

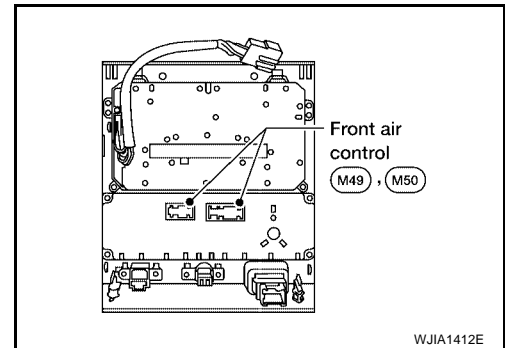

### Potential Temperature Control (PTC)

The PTC is built into the front air control. It can be set from cold to hot or any intermediate position by rotating the temperature dial.

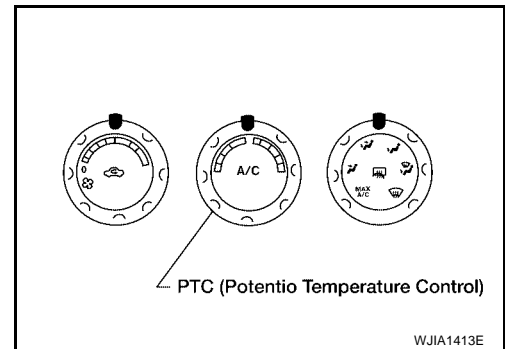

## DIAGNOSTIC PROCEDURE FOR A/C SYSTEM

SYMPTOM: A/C system does not come on.

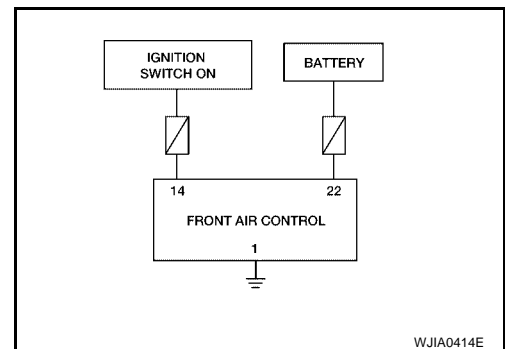

# TROUBLE DIAGNOSIS

## 1. CHECK POWER SUPPLY CIRCUITS FOR FRONT AIR CONTROL

1. Disconnect front air control connector.
2. Check voltage between front air control harness connector M49 terminals 14 (Y/G) and 22 (Y/R), and ground.

Terminals		Ignition switch position			
(+)		(-)	OFF	ACC	ON
Front air control connector	Terminal No. (Wire color)				
M49	14 (Y/G)	Ground	Approx. 0V	Approx. 0V	Battery voltage
M49	22 (Y/R)		Battery voltage	Battery voltage	Battery voltage

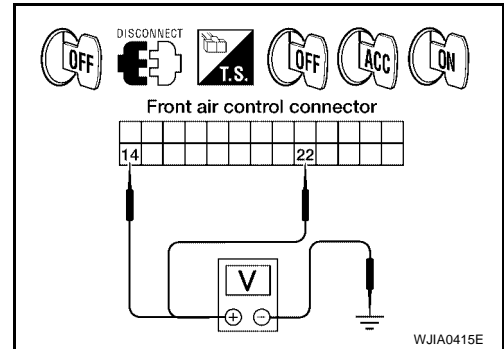

### OK or NG

OK >> GO TO 2.

NG >> Check 10A fuses [Nos. 8 and 19, located in the fuse block (J/B)]. Refer to [PG-77, "FUSE BLOCK-JUNCTION BOX\(J/B\)"](#).

- If fuses are OK, check harness for open circuit. Repair or replace as necessary.
- If fuses are NG, replace fuse and check harness for short circuit. Repair or replace as necessary.

## 2. CHECK GROUND CIRCUIT FOR FRONT AIR CONTROL

1. Turn ignition switch OFF.
2. Check continuity between front air control harness connector M49 terminal 1 (B) and ground.

**1 - Ground : Continuity should exist.**

### OK or NG

OK >> Replace front air control. Refer to [MTC-95, "CONTROL UNIT"](#).

NG >> Repair harness or connector.

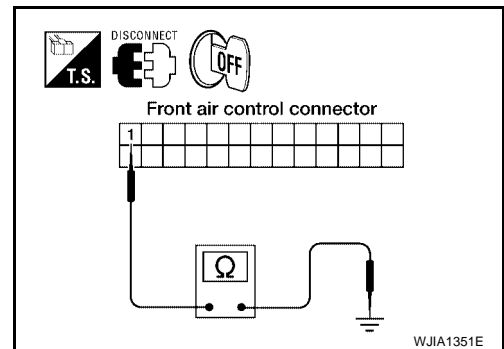

# TROUBLE DIAGNOSIS

EJS003U6

## Mode Door Motor Circuit

### SYMPTOM:

- Air outlet does not change.
- Mode door motor does not operate normally.

### INSPECTION FLOW

1. Confirm symptom by performing the following operational check.

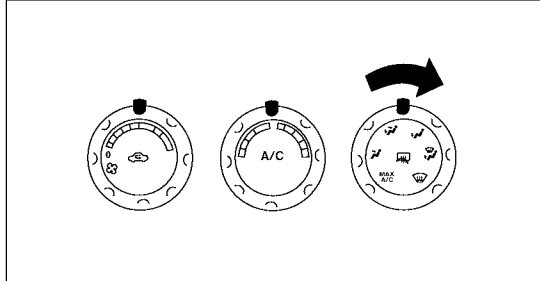

#### OPERATIONAL CHECK – Discharge air

a. Turn the mode dial four times and DEF position.

#### Discharge air flow

Mode door position	Air outlet/distribution		
	Vent	Foot	Defroster
	100%	–	–
	60%	40%	–
	–	100%	–
	–	60%	40%
	–	–	100%

b. Confirm that discharge air comes out according to the air distribution table at left.

Refer to "Discharge Air Flow" (\*1).

#### NOTE:

- If OK (symptom cannot be duplicated), perform complete operational check (\*2).
- If NG (symptom is confirmed), continue with STEP-2 following.
- Confirm that the compressor clutch is engaged (visual inspection) and intake door position is at FRESH when DEF or D/F is selected.

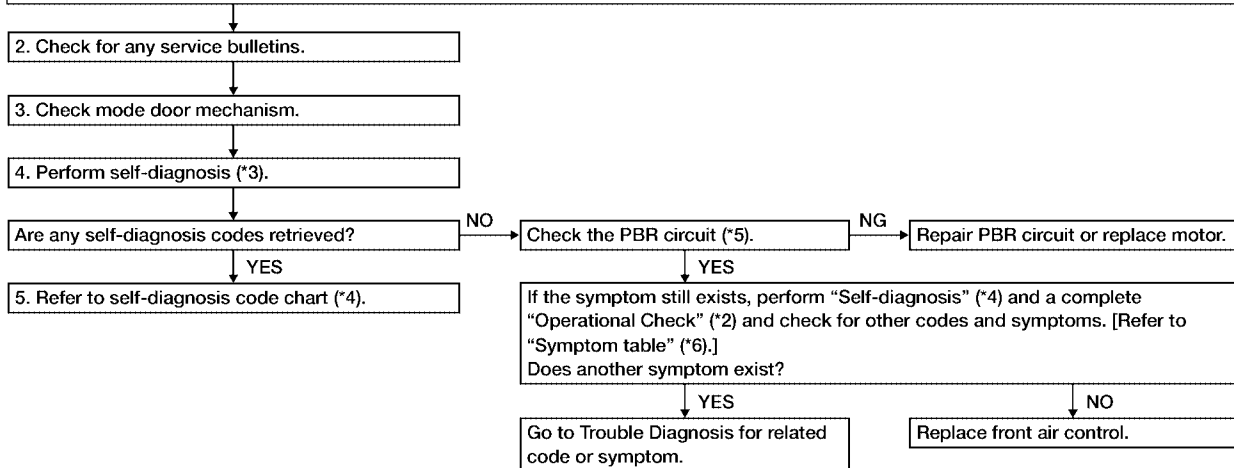

WJIA1425E

\*1 [MTC-25, "Discharge Air Flow"](#).

\*2 [MTC-47, "Operational Check"](#).

\*3 [MTC-45, "A/C System Self-diagnosis Function \(With NAVI Only\)"](#).

\*4 [MTC-46, "SELF-DIAGNOSIS CODE CHART"](#).

\*5 [MTC-53, "DIAGNOSTIC PROCEDURE FOR MODE DOOR MOTOR"](#).

\*6 [MTC-33, "SYMPTOM TABLE"](#).

# TROUBLE DIAGNOSIS

## SYSTEM DESCRIPTION

### Component Parts

Mode door control system components are:

- Front air control
- Mode door motor
- PBR (built into mode door motor)

### System Operation

The mode door position (vent, B/L, foot, and defrost) is set by the front air control by means of the mode door motor. When a mode door position is selected on the front air control, voltage is applied to one circuit of the mode door motor while ground is applied to the other circuit, causing the mode door motor to rotate. The direction of rotation is determined by which circuit has voltage applied to it, and which one has ground applied to it. The front air control monitors the mode door position by measuring the voltage signal on the PBR circuit.

## COMPONENT DESCRIPTION

### Mode Door Motor

The mode door motor is attached to the heater & cooling unit. It rotates so that air is discharged from the outlet as indicated by the front air control. Motor rotation is conveyed to a link which activates the mode door.

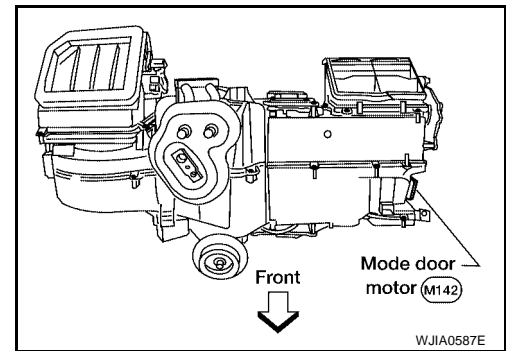

## DIAGNOSTIC PROCEDURE FOR MODE DOOR MOTOR

### 1. CHECK RESULT FROM FRONT AIR CONTROL SELF-DIAGNOSIS

Self-diagnosis code 92 or DTC B2588 is present. Refer to [MTC-45, "A/C System Self-diagnosis Function \(With NAVI Only\)"](#).

YES or NO

- YES >> GO TO 2.
- NO >> GO TO 3.

### 2. CHECK POWER SUPPLY AND GROUND CIRCUITS FOR MODE DOOR MOTOR

1. Turn ignition switch OFF.
2. Disconnect front air control connector and mode door motor connector.
3. Check continuity between front air control harness connector M49 terminal 5 (BR/W) and mode door motor harness connector M142 terminal 5 (BR/W) and between front air control harness connector M49 terminal 6 (P/L) and mode door motor harness connector M142 terminal 6 (P/L).

**5 - 5 : Continuity should exist.**

**6 - 6 : Continuity should exist.**

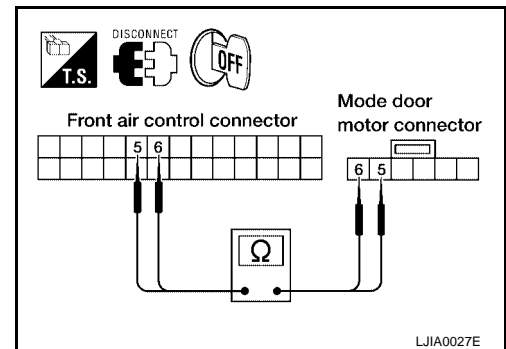

OK or NG

- OK >> Replace mode door motor. Refer to [MTC-106, "MODE DOOR MOTOR"](#).
- NG >> Repair or replace harness as necessary.

# TROUBLE DIAGNOSIS

## 3. CHECK PBR REFERENCE SIGNAL VOLTAGE

1. Disconnect the mode door motor connector.
2. Turn ignition switch ON.
3. Check voltage between mode door motor harness connector M142 terminal 3 (Y) and ground.

**3 - Ground : Approx. 5V**

OK or NG

- OK >> GO TO 5.  
NG >> GO TO 4.

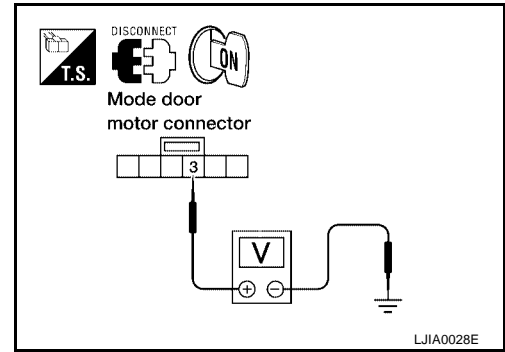

## 4. CHECK PBR REFERENCE VOLTAGE CIRCUIT BETWEEN MODE DOOR AND FRONT AIR CONTROL

1. Turn ignition switch OFF.
2. Disconnect the front air control connector.
3. Check continuity between mode door motor harness connector M142 terminal 3 (Y) and front air control harness connector M49 terminal 2 (Y).

**3 - 2 : Continuity should exist.**

OK or NG

- OK >> Replace front air control. Refer to [MTC-95, "CONTROL UNIT"](#).
- NG >> Repair or replace harness as necessary.

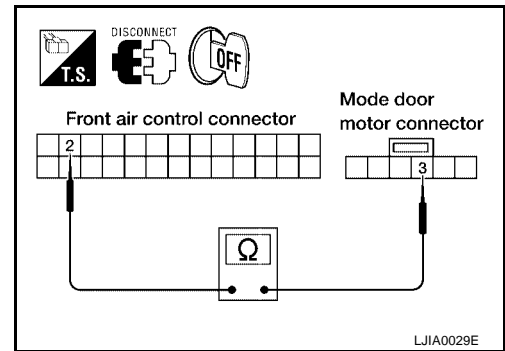

## 5. CHECK PBR GROUND REFERENCE CIRCUIT

1. Turn ignition switch OFF.
2. Disconnect the front air control connector.
3. Check continuity between mode door motor harness connector M142 terminal 1 (P) and front air control harness connector M49 terminal 15 (P).

**1 - 15 : Continuity should exist.**

OK or NG

- OK >> GO TO 6.  
NG >> Repair or replace harness as necessary.

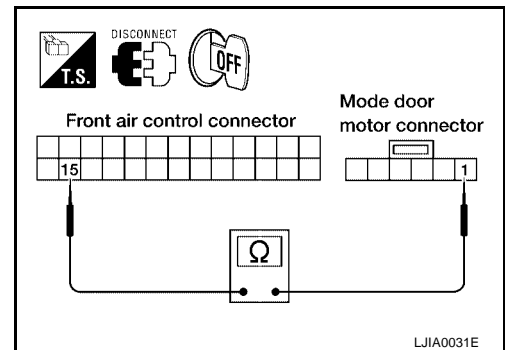

## 6. CHECK PBR FEEDBACK SIGNAL

1. Reconnect the front air control connector and mode door motor connector.
2. Turn ignition switch ON.
3. Check voltage between front air control harness connector M49 terminal 16 (GR) and ground.
4. Press mode switch through all modes.

**16 - Ground : Approx. 0 - 5V**

OK or NG

- OK >> Replace front air control. Refer to [MTC-95, "CONTROL UNIT"](#).
- NG >> GO TO 7.

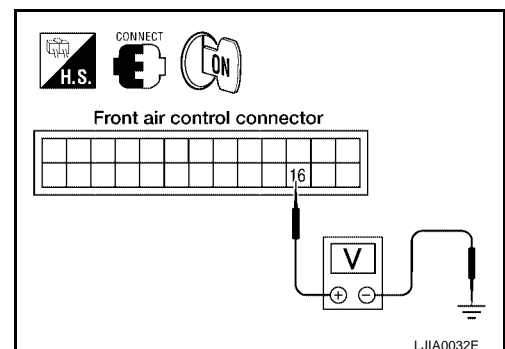

# TROUBLE DIAGNOSIS

## 7. CHECK PBR FEEDBACK CIRCUIT

1. Turn ignition switch OFF.
2. Disconnect the mode door motor connector and front air control harness connector.
3. Check continuity between mode door motor harness connector M142 terminal 2 (GR) and front air control harness connector M49 terminal 16 (GR).

**2 - 16**

**: Continuity should exist.**

OK or NG

OK >> Replace mode door motor. Refer to [MTC-106, "MODE DOOR MOTOR"](#).

NG >> Repair or replace harness as necessary.

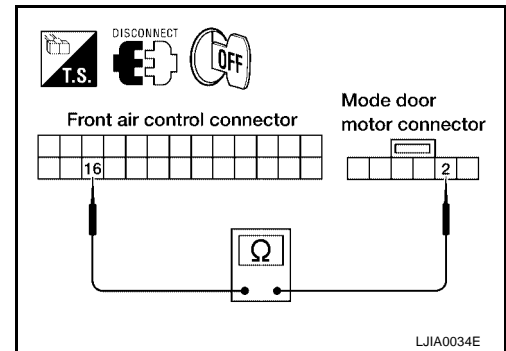

A

B

C

D

E

F

G

H

I

MTC

K

L

M

# TROUBLE DIAGNOSIS

EJS003U7

## Air Mix Door Motor Circuit

### SYMPTOM:

- Discharge air temperature does not change.
- Air mix door motor does not operate.

### INSPECTION FLOW

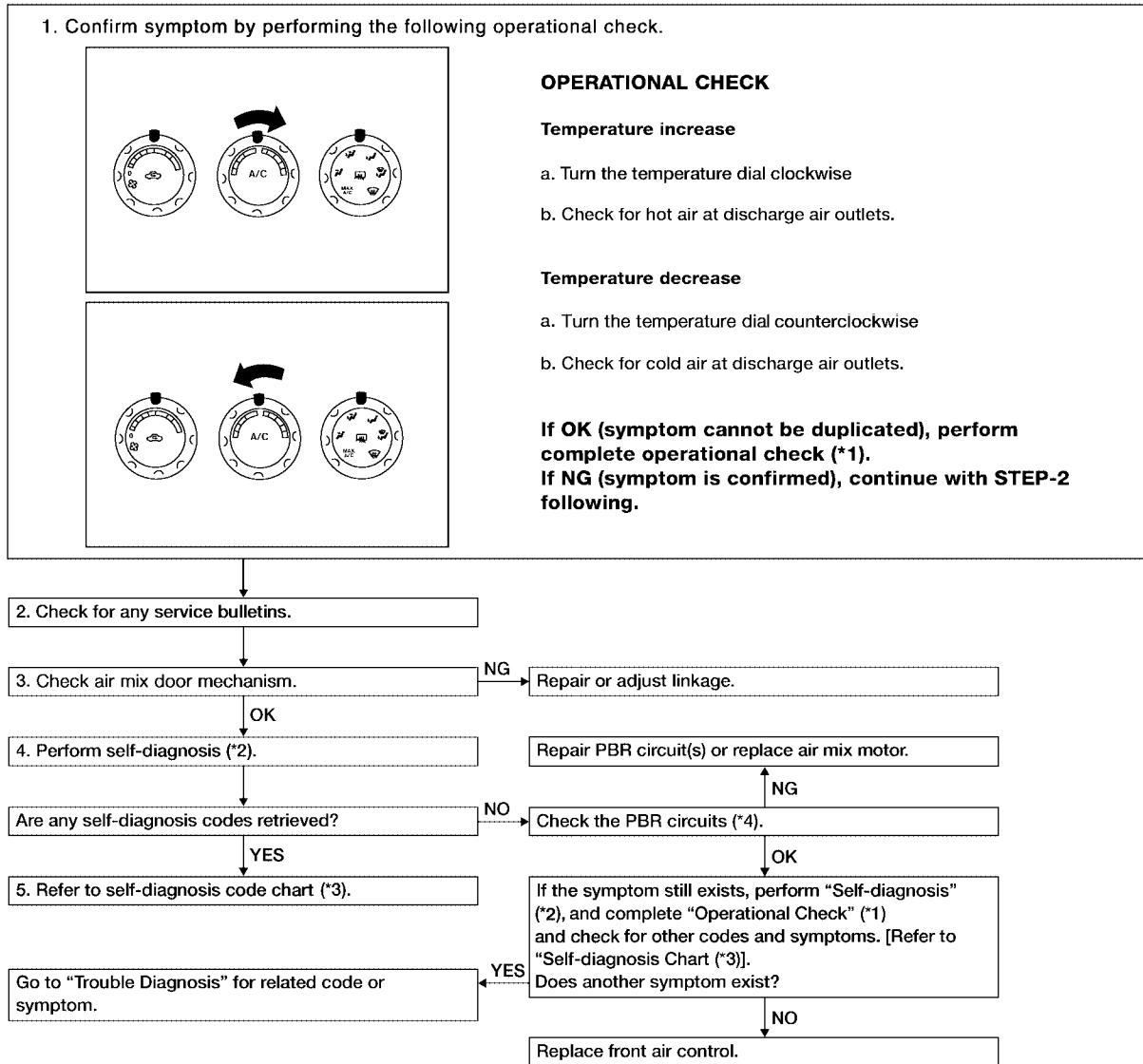

\*1 [MTC-47. "Operational Check".](#)

\*2 [MTC-45. "A/C System Self-diagnosis Function \(With NAVI Only\)".](#)

\*3 [MTC-46. "SELF-DIAGNOSIS CODE CHART".](#)

\*4 [MTC-58. "DIAGNOSTIC PROCEDURE FOR AIR MIX DOOR MOTOR \(FRONT\)".](#)

WJIA1432E



# TROUBLE DIAGNOSIS

## SYSTEM DESCRIPTION

### Component Parts

Air mix door control system components are:

- Front air control
- Air mix door motors (Front)
- PBR (built-into air mix motors)

### System Operation

The front air control receives data from the temperature selected by the driver. The front air control then applies a voltage to one circuit of the appropriate air mix door motor, while ground is applied to the other circuit, causing the appropriate air mix door motor to rotate. The direction of rotation is determined by which circuit has voltage applied to it, and which one has ground applied to it. The front air control monitors the air mix door positions by measuring the voltage signal on the PBR circuits of each door.

### Air Mix Door Control Specification

#### COMPONENT DESCRIPTION

#### Air Mix Door Motors

The front air mix door motor is attached to the front heater & cooling unit. This motor rotates so that the air mix door is opened or closed to a position set by the front air control. Motor rotation is then conveyed through a shaft and the air mix door position is then fed back to the front air control by the PBR built into the air mix door motors.

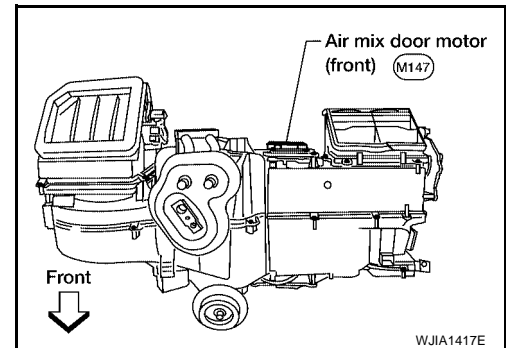
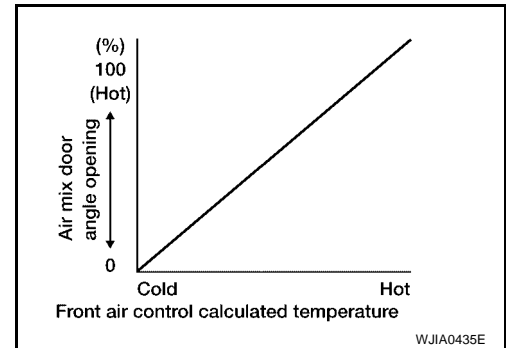

A  
B  
C  
D  
E  
F  
G  
H  
I  
MTC  
K  
L  
M

# TROUBLE DIAGNOSIS

## DIAGNOSTIC PROCEDURE FOR AIR MIX DOOR MOTOR (FRONT)

### 1. CHECK RESULT FROM FRONT AIR CONTROL SELF-DIAGNOSIS

Self-diagnosis code 22 or DTC B2577 is present. Refer to [MTC-45, "A/C System Self-diagnosis Function \(With NAVI Only\)"](#).

YES or NO

- YES >> GO TO 2.
- NO >> GO TO 3.

### 2. CHECK POWER SUPPLY CIRCUITS FOR AIR MIX DOOR MOTOR (FRONT)

1. Turn ignition switch OFF.
2. Disconnect front air control connector and air mix door motor (front) connector.
3. Check continuity between front air control harness connector M49 terminal 3 (W/G) and 4 (G) and air mix door motor (front) harness connector M147 terminal 1 (W/G) and 6 (G).

- 3 - 1 : Continuity should exist.**
- 4 - 6 : Continuity should exist.**

OK or NG

- OK >> Replace air mix door motor (front). Refer to [MTC-107, "AIR MIX DOOR MOTOR"](#).
- NG >> Repair or replace harness as necessary.

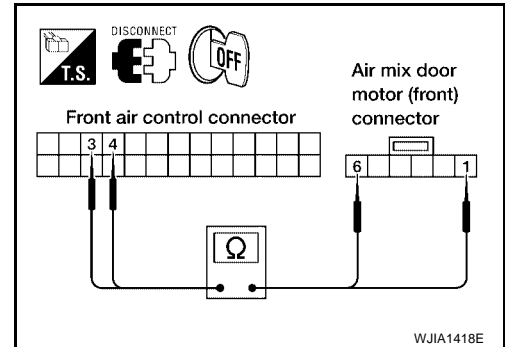

### 3. CHECK PBR REFERENCE SIGNAL VOLTAGE

1. Turn ignition switch OFF.
2. Disconnect the air mix door motor (front) connector.
3. Turn ignition switch ON.
4. Check voltage between air mix door motor (front) harness connector M147 terminal 3 (Y) and ground.

- 3 - Ground : Approx. 5V**

OK or NG

- OK >> GO TO 5.
- NG >> GO TO 4.

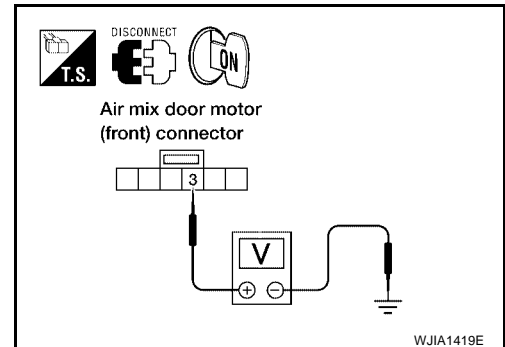

### 4. CHECK PBR REFERENCE VOLTAGE CIRCUIT BETWEEN AIR MIX DOOR MOTOR (FRONT) AND FRONT AIR CONTROL

1. Turn ignition switch OFF.
2. Disconnect the front air control connector.
3. Check continuity between air mix door motor (front) harness connector M147 terminal 3 (Y) and front air control harness connector M49 terminal 2 (Y).

- 3 - 2 : Continuity should exist.**

OK or NG

- OK >> Replace front air control. Refer to [MTC-95, "CONTROL UNIT"](#).
- NG >> Repair or replace harness as necessary.

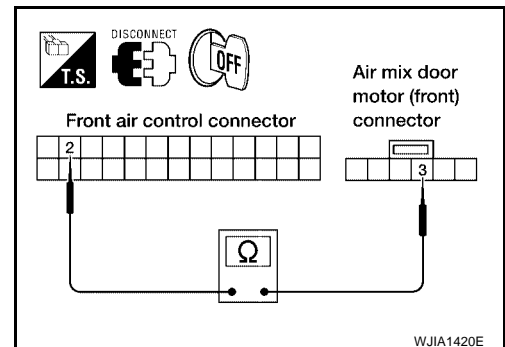

# TROUBLE DIAGNOSIS

## 5. CHECK PBR GROUND REFERENCE CIRCUIT

1. Turn ignition switch OFF.
2. Disconnect the front air control connector.
3. Check continuity between air mix door motor (front) harness connector M147 terminal 2 (P) and front air control harness connector M49 terminal 15 (P).

**2 - 15 : Continuity should exist.**

OK or NG

OK >> GO TO 6.

NG >> Repair or replace harness as necessary.

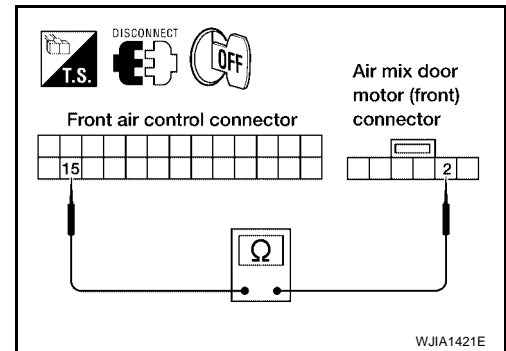

## 6. CHECK PBR FEEDBACK SIGNAL

1. Reconnect the front air control connector and air mix door motor (Front) connector.
2. Turn ignition switch ON.
3. Check voltage between front air control harness connector M49 terminal 18 (SB) and ground.
4. Rotate Front temperature control dial through complete range.

**18 - Ground : Approx. 0V - 5V**

OK or NG

OK >> Replace front air control. Refer to [MTC-95, "CONTROL UNIT"](#).

NG >> GO TO 7.

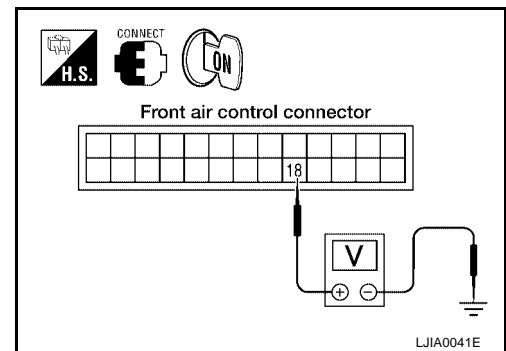

## 7. CHECK PBR FEEDBACK CIRCUIT

1. Turn ignition switch OFF.
2. Disconnect the air mix door motor (front) connector and front air control connector.
3. Check continuity between air mix door motor (front) harness connector M147 terminal 4 (SB) and front air control harness connector M49 terminal 18 (SB).

**4 - 18 Continuity should exist.**

OK or NG

OK >> Replace air mix door motor (Front). Refer to [MTC-107, "AIR MIX DOOR MOTOR"](#).

NG >> Repair or replace harness as necessary.

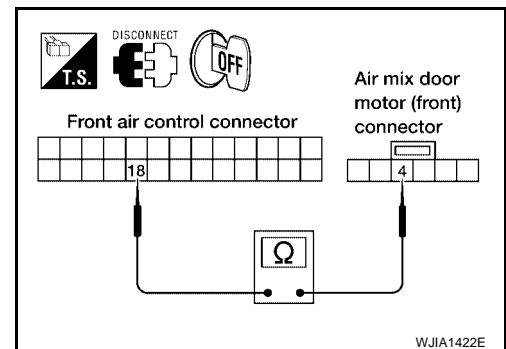

A  
B  
C  
D  
E  
F  
G  
H  
I  
K  
L  
M

MTC

# TROUBLE DIAGNOSIS

EJS003U8

## Intake Door Motor Circuit

### SYMPTOM:

- Intake door does not change.
- Intake door motor does not operate normally.

### INSPECTION FLOW

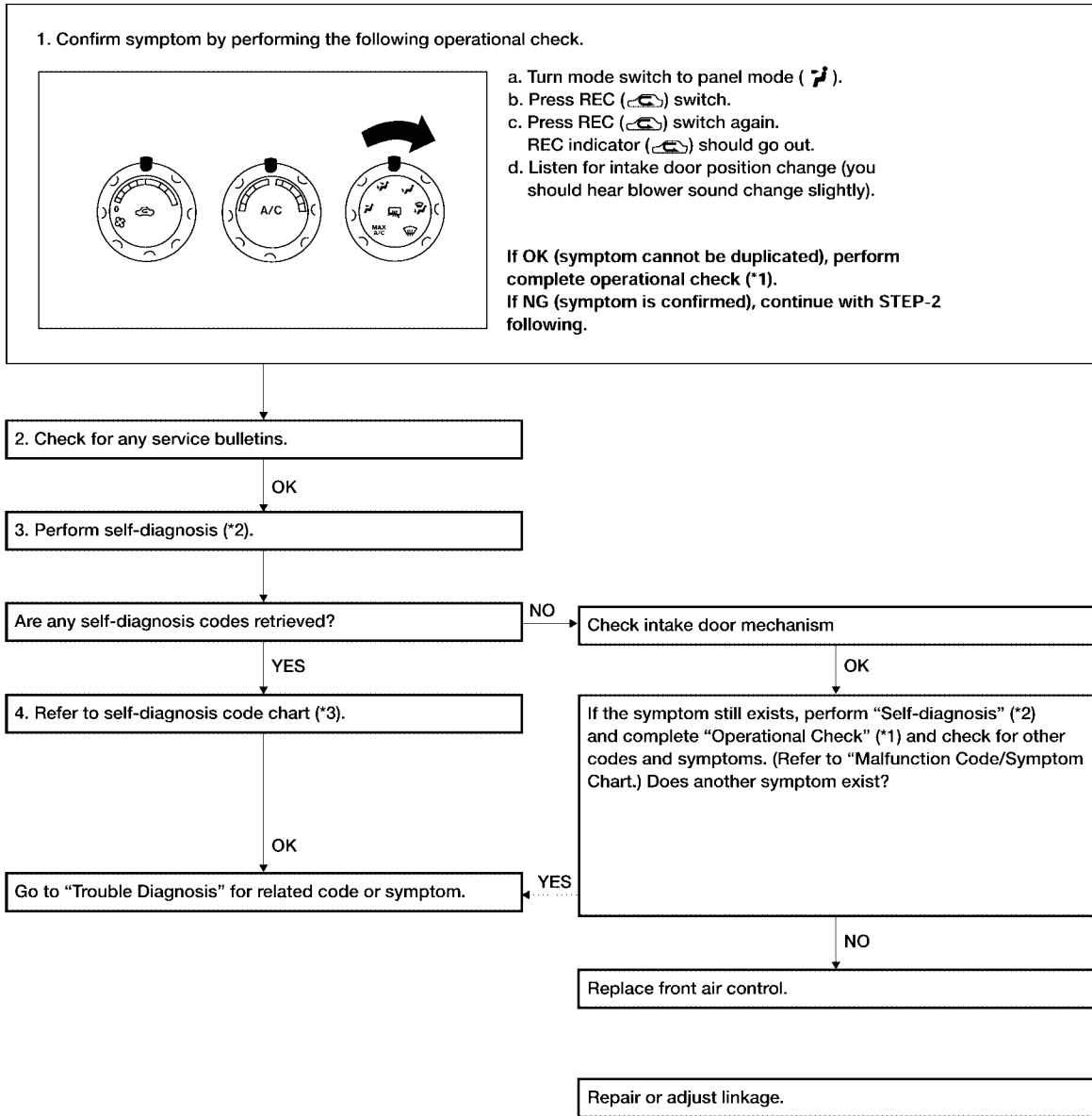

\*1 [MTC-47. "Operational Check"](#).

\*2 [MTC-45. "A/C System Self-diagnosis Function \(With NAVI Only\)"](#).

\*3 [MTC-46. "SELF-DIAGNOSIS CODE CHART"](#).

WJIA1433E

# TROUBLE DIAGNOSIS

## SYSTEM DESCRIPTION

### Component Parts

Intake door control system components are:

- Front air control
- Intake door motor

### System Operation

The intake door control determines the intake door positions based on the position of the recirculation switch. When the recirculation switch is depressed the intake door motor rotates closing off the fresh air inlet and recirculating the cabin air. If the recirculation switch is depressed again, the intake door motor rotates in the opposite direction, again allowing fresh air into the cabin.

### Intake Doors Control Specification

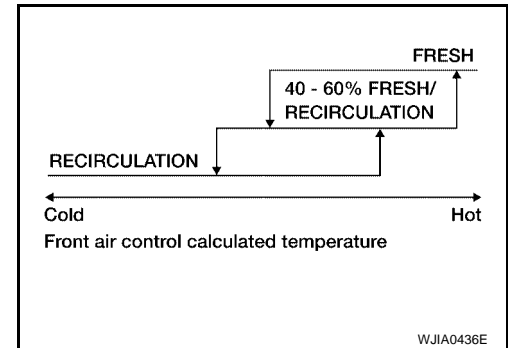

## COMPONENT DESCRIPTION

### Intake door motor

The intake door motor is attached to the intake unit. It rotates so that air is drawn from inlets set by the front air control. Motor rotation is conveyed to a lever which activates the intake door.

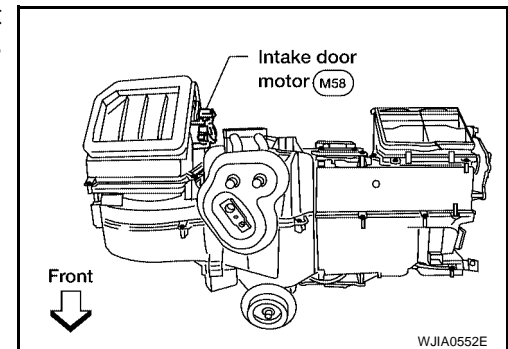

A  
B  
C  
D  
E  
F  
G  
H  
I  
MTC  
K  
L  
M

# TROUBLE DIAGNOSIS

## DIAGNOSTIC PROCEDURE FOR INTAKE DOOR MOTOR

### 1. CHECK RESULT FROM FRONT AIR CONTROL SELF-DIAGNOSIS

Self-diagnosis code 82 or DTC B2586 is present. Refer to [MTC-45, "A/C System Self-diagnosis Function \(With NAVI Only\)"](#) .

YES or NO

YES >> GO TO 2.

NO >> Replace front air control. Refer to [MTC-95, "CONTROL UNIT"](#) .

### 2. CHECK POWER SUPPLY CIRCUIT FOR INTAKE DOOR MOTOR

1. Turn ignition switch OFF.
2. Disconnect front air control connector and intake door motor connector.
3. Check continuity between front air control harness connector M49 terminal 7 (O) and intake door motor harness connector M58 terminal 1 (O) and between front air control harness connector M49 terminal 8 (G/B) and intake door motor harness connector M58 terminal 6 (G/B).

**7 - 1**

**Continuity should exist.**

**8 - 6**

**Continuity should exist.**

OK or NG

OK >> Replace intake door motor. Refer to [MTC-105, "INTAKE DOOR MOTOR"](#) .

NG >> Repair or replace harness as necessary.

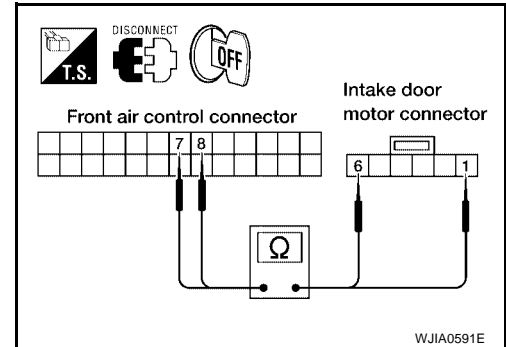

# TROUBLE DIAGNOSIS

EJS003U9

## Defroster Door Motor Circuit

### SYMPTOM:

- Defroster door does not change.
- Defroster door motor does not operate normally.

### INSPECTION FLOW

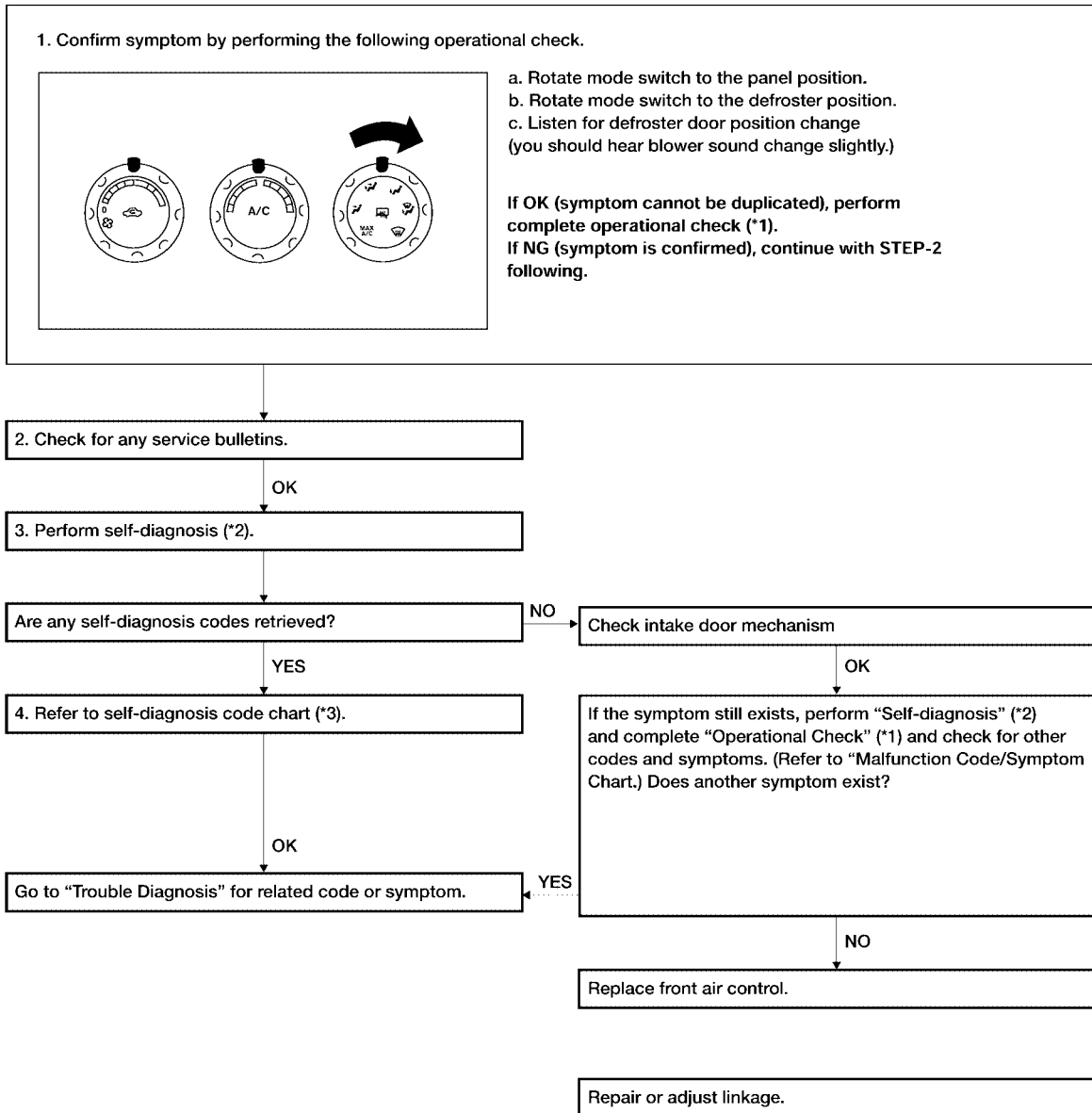

\*1 [MTC-47, "Operational Check"](#).

\*2 [MTC-45, "A/C System Self-diagnosis Function \(With NAVI Only\)"](#).

\*3 [MTC-46, "SELF-DIAGNOSIS CODE CHART"](#).

WJIA1423E

# TROUBLE DIAGNOSIS

## SYSTEM DESCRIPTION

### Component Parts

Defroster door control system components are:

- Front air control
- Defroster door motor

### System Operation

The front air control determines defroster door position based on the position of the mode switch. When the mode switch is in the defroster position, the defroster door motor rotates directing air to the defroster ducts. When any mode other than defroster is selected, the defroster motor rotates in the opposite direction closing off air flow to the defroster ducts.

## COMPONENT DESCRIPTION

### Defroster door motor

The defroster door motor is attached to the front heater & cooling unit. The front air control sends a voltage to rotate the defroster door directing the air flow either to the defroster ducts, or to the floor ducts, depending on which way the voltage and ground are applied to the motor leads. Motor rotation is conveyed to a lever which activates the defroster door.

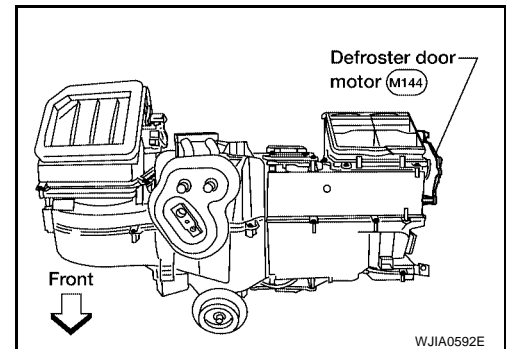

## DIAGNOSTIC PROCEDURE FOR DEFROSTER DOOR MOTOR

### 1. CHECK RESULT FROM FRONT AIR CONTROL SELF-DIAGNOSIS

Self-diagnosis code 62 or DTC B2583 is present. Refer to [MTC-45, "A/C System Self-diagnosis Function \(With NAVI Only\)"](#).

YES or NO

- YES >> GO TO 2.
- NO >> GO TO 3.

### 2. CHECK POWER SUPPLY CIRCUIT FOR DEFROSTER DOOR MOTOR

1. Turn ignition switch OFF.
2. Disconnect front air control connector and defroster door motor connector.
3. Check continuity between front air control harness connector M49 terminal 19 (LG) and defroster door motor connector M144 terminal 1 (LG) and between front air control harness connector M49 terminal 20 (P/B) and defroster door motor connector M144 terminal 6 (P/B).

- 19 - 1 : Continuity should exist.**
- 20 - 6 : Continuity should exist.**

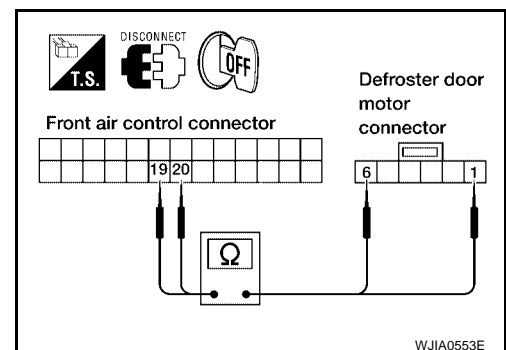

OK or NG

- OK >> Replace defroster door motor. Refer to [MTC-104, "DEFROSTER DOOR MOTOR"](#).
- NG >> Repair or replace harness as necessary.



# TROUBLE DIAGNOSIS

## 3. CHECK PBR REFERENCE SIGNAL VOLTAGE

1. Disconnect the defroster door motor harness connector.
2. Turn ignition switch ON.
3. Check voltage between defroster door motor harness connector M144 terminal 3 (Y) and ground.

**3 - Ground : Approx. 5V.**

OK or NG

- OK >> GO TO 5.  
NG >> GO TO 4.

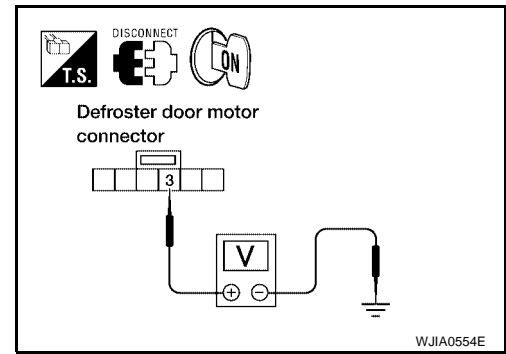

## 4. CHECK PBR REFERENCE VOLTAGE CIRCUIT BETWEEN DEFROSTER DOOR MOTOR AND FRONT AIR CONTROL

1. Turn ignition switch OFF.
2. Disconnect the front air control connector.
3. Check continuity between defroster door motor harness connector M144 terminal 3 (Y) and front air control harness connector M49 terminal 2 (Y).

**3 - 2 : Continuity should exist.**

OK or NG

- OK >> Replace front air control. Refer to [MTC-95, "CONTROL UNIT"](#).  
NG >> Repair or replace harness as necessary.

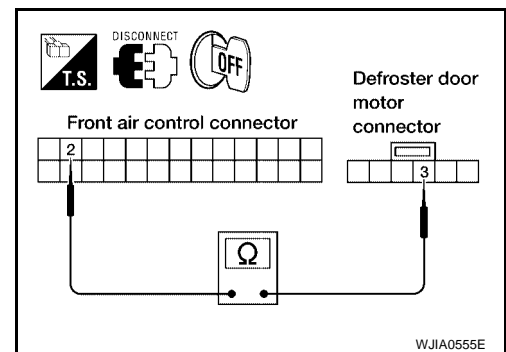

## 5. CHECK PBR GROUND REFERENCE CIRCUIT

1. Turn ignition switch OFF.
2. Disconnect the front air control connector.
3. Check continuity between defroster door motor harness connector M144 terminal 2 (P) and front air control harness connector M49 terminal 15 (P).

**2 - 15 : Continuity should exist.**

OK or NG

- OK >> GO TO 6.  
NG >> Repair or replace harness as necessary.

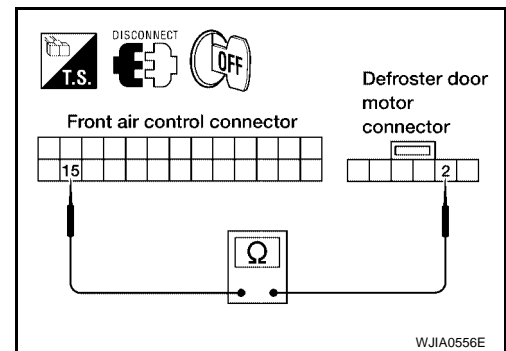

## 6. CHECK PBR FEEDBACK SIGNAL

1. Reconnect the front air control connector and defroster door motor connector.
2. Turn ignition switch ON.
3. Check voltage between front air control harness connector M49 terminal 25 (LG/B) and ground.
4. Change mode between floor, defroster, and panel.

**25 - Ground : Approx. 0 - 5V**

OK or NG

- OK >> Replace front air control. Refer to [MTC-95, "CONTROL UNIT"](#).  
NG >> GO TO 7.

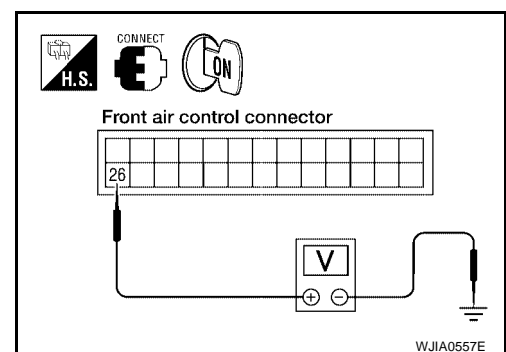

# TROUBLE DIAGNOSIS

## 7. CHECK PBR FEEDBACK CIRCUIT

1. Turn ignition switch OFF.
2. Disconnect the defroster door motor connector and front air control connector.
3. Check continuity between defroster door motor harness connector M144 terminal 4 (LG/B) and front air control harness connector M49 terminal 25 (LG/B).

**4 - 25**

**: Continuity should exist.**

OK or NG

OK >> Replace defroster door motor. Refer to [MTC-104](#), "[DEFROSTER DOOR MOTOR](#)".

NG >> Repair or replace harness as necessary.

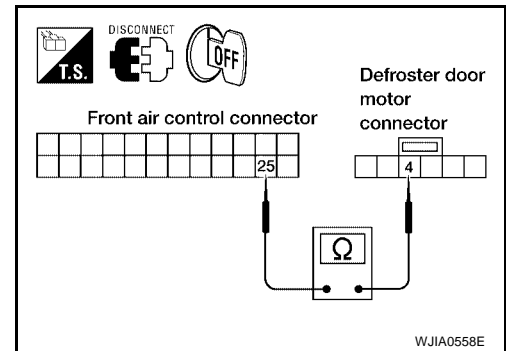

# TROUBLE DIAGNOSIS

EJS003UA

## Front Blower Motor Circuit

### SYMPTOM:

- Blower motor operation is malfunctioning.
- Blower motor operation is malfunctioning under cold starting conditions.

### INSPECTION FLOW

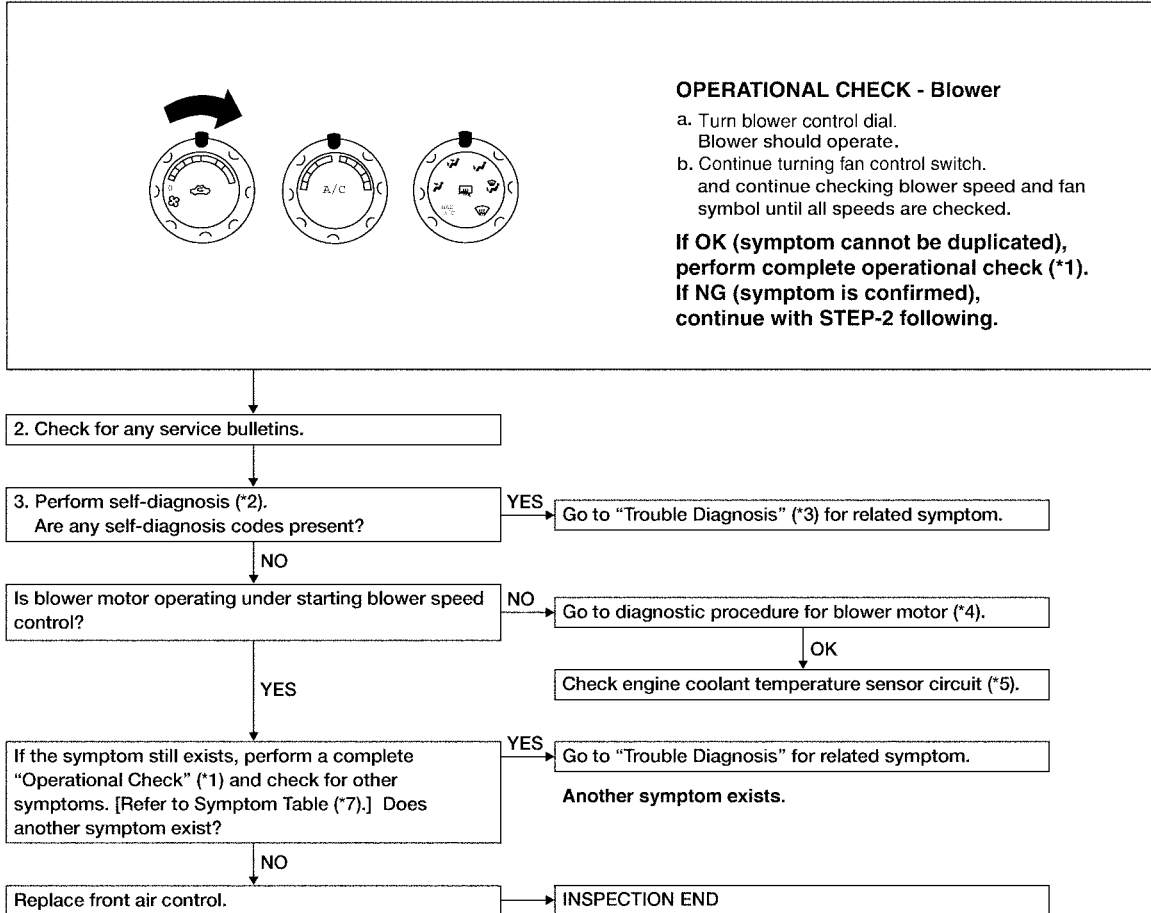

\*1 [.MTC-47. "Operational Check" .](#)

\*2 [MTC-45. "A/C System Self-diagnosis Function \(With NAVI Only\)".](#)

\*3 [MTC-46. "SELF-DIAGNOSIS CODE CHART".](#)

\*4 [MTC-69. "DIAGNOSTIC PROCEDURE FOR BLOWER MOTOR".](#)

\*5 [EC-192. "DTC P0117, P0118 ECT SENSOR" EC-205. "DTC P0125 ECT SENSOR"](#)

WJIA1451E

# TROUBLE DIAGNOSIS

## SYSTEM DESCRIPTION

### Component Parts

- Front air control
- Front blower switch
- Variable blower control
- Front blower motor
- Front blower motor relay

### System Operation

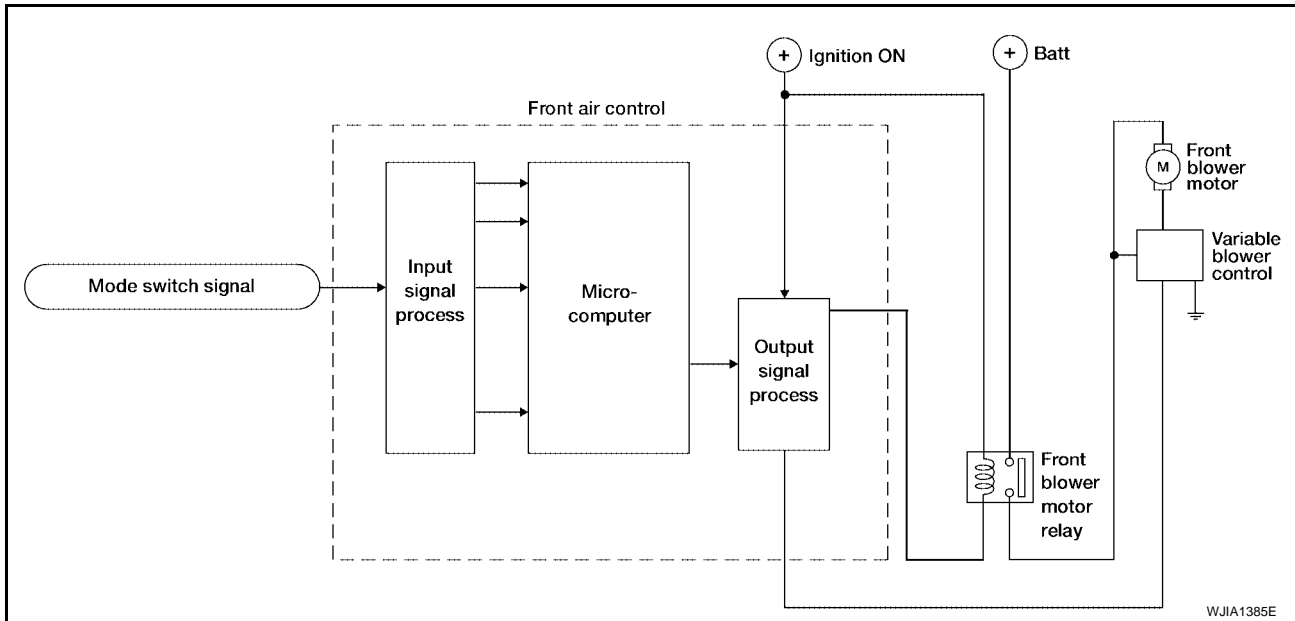

## COMPONENT DESCRIPTION

### Variable Blower Control

The variable blower control is located on the cooling unit. The variable blower control receives a gate voltage from the front air control to steplessly maintain the blower motor voltage in the 0 to 5 volt range (approx.).

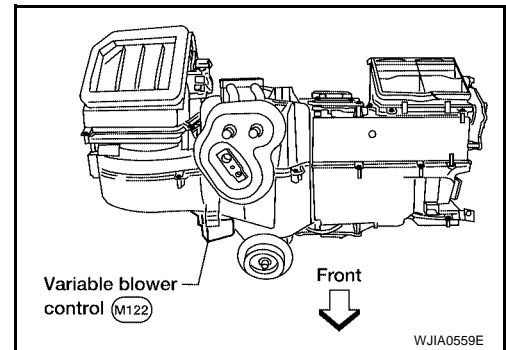

# TROUBLE DIAGNOSIS

## DIAGNOSTIC PROCEDURE FOR BLOWER MOTOR

SYMPTOM: Blower motor operation is malfunctioning under starting blower speed control.

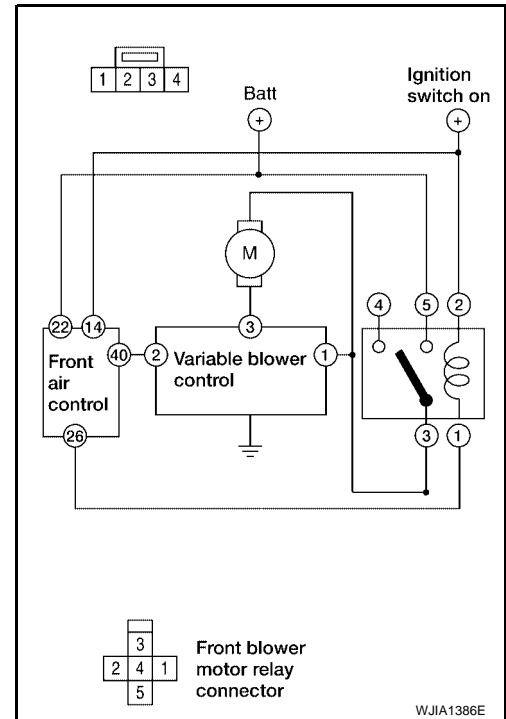

### 1. CHECK FUSES

Check 20A fuses [No. 24 and 27 (Located in the fuse and fusible link box)]. For fuse layout. Refer to [PG-78](#), "[FUZE AND FUSIBLE LINK BOX](#)".

**Fuses are good.**

OK or NG

- OK >> GO TO 2.
- NG >> GO TO 10.

### 2. CHECK FRONT BLOWER MOTOR POWER SUPPLY CIRCUIT

1. Turn ignition switch OFF.
2. Disconnect front blower motor connector.
3. Press the mode switch to select any mode except off.
4. Turn the front blower control dial to high.
5. Check voltage between front blower motor harness connector M62 terminal 2 (W/L) and ground.

**2 - Ground : Battery voltage.**

OK or NG

- OK >> GO TO 12.
- NG >> GO TO 3.

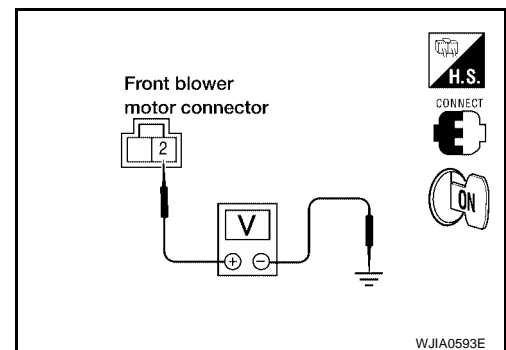

# TROUBLE DIAGNOSIS

## 3. CHECK FRONT BLOWER MOTOR RELAY (SWITCH SIDE) POWER SUPPLY CIRCUIT

1. Turn ignition switch OFF.
2. Disconnect front blower motor relay.
3. Turn ignition switch ON.
4. Check voltage between front blower motor relay harness connector M107 terminals 5 (GR) and ground.

**5 - Ground** : **Battery voltage.**

OK or NG

- OK >> GO TO 4.  
NG >> Repair harness or connector.

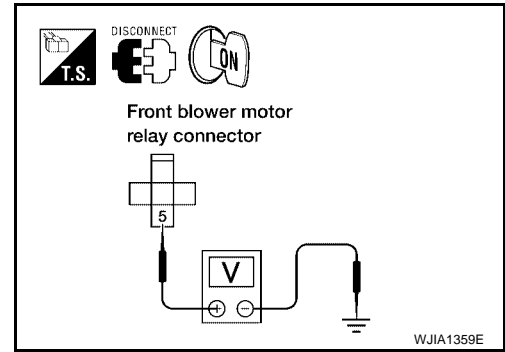

## 4. CHECK FRONT BLOWER MOTOR RELAY

Turn ignition switch OFF.

Refer to [MTC-73, "Front Blower Motor Relay"](#).

OK or NG

- OK >> GO TO 5.  
NG >> Replace front blower motor relay.

## 5. CHECK FRONT BLOWER MOTOR RELAY (SWITCH SIDE) CIRCUIT FOR OPEN

Check continuity between front blower motor relay harness connector M107 terminal 3 (W/L) and front blower motor harness connector M62 terminal 2 (W/L).

**3 - 2** : **Continuity should exist.**

OK or NG

- OK >> GO TO 6.  
NG >> Repair harness or connector.

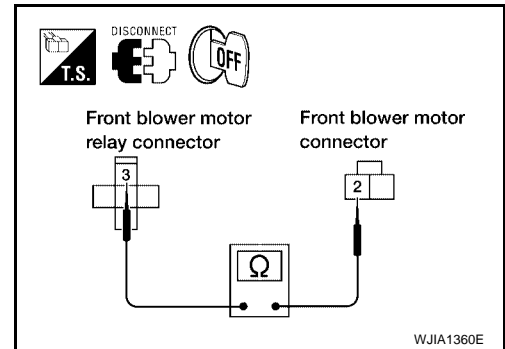

## 6. CHECK VARIABLE BLOWER CONTROL POWER SUPPLY CIRCUIT FOR OPEN

1. Disconnect variable blower control harness connector.
2. Check continuity between front blower motor relay harness connector M107 terminals 3 (W/L) and variable blower control harness connector M122 terminal 1 (W/L).

**3 - 1** : **Continuity should exist.**

OK or NG

- OK >> GO TO 7.  
NG >> Repair harness or connector.

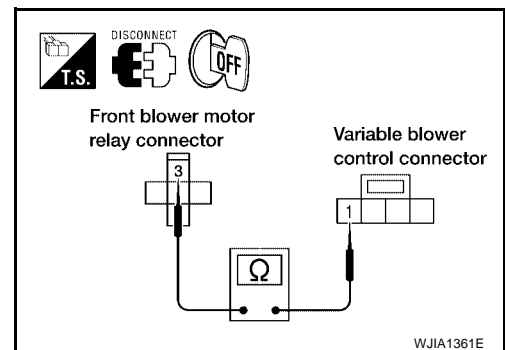

# TROUBLE DIAGNOSIS

## 7. CHECK VARIABLE BLOWER CONTROL SIGNAL CIRCUIT

1. Disconnect front air control connector.
2. Check continuity between front air control harness connector M49 terminal 40 (G/R) and variable blower control harness connector M122 terminal 2 (G/R).

**40 - 2 : Continuity should exist.**

OK or NG

- OK >> GO TO 8.  
NG >> Repair harness or connector.

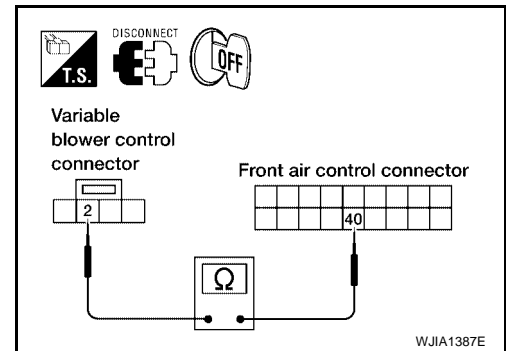

## 8. CHECK FRONT BLOWER MOTOR RELAY (COIL SIDE) POWER SUPPLY

1. Turn ignition switch ON.
2. Check voltage between front blower motor relay harness connector M107 terminal 2 (Y/G) and ground.

**2 - Ground : Battery voltage.**

OK or NG

- OK >> GO TO 9.  
NG >> Repair harness or connector.

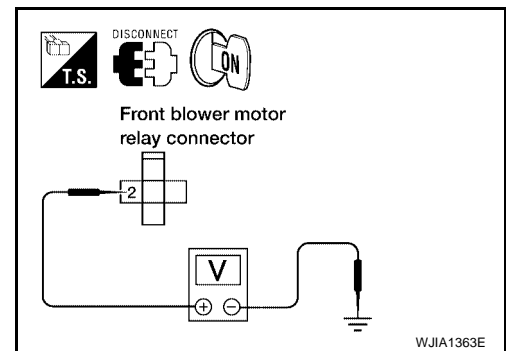

## 9. CHECK FRONT BLOWER MOTOR RELAY (COIL SIDE) GROUND CIRCUIT

1. Turn ignition switch OFF.
2. Check continuity between front blower motor relay connector M107 terminal 1 (R/B) and front air control harness connector M49 terminal 26 (R/B).

**1 - 26 : Continuity should exist.**

OK or NG

- OK >> Replace front air control. Refer to [MTC-95, "CONTROL UNIT"](#).
- NG >> Repair harness or connector.

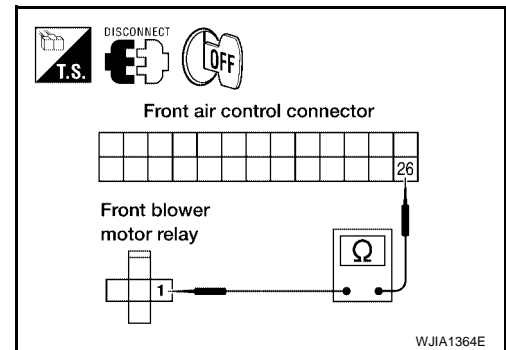

## 10. REPLACE FUSES

1. Replace fuses.
2. Activate the front blower motor.
3. Do fuses blow?

YES or NO

- YES >> GO TO 11.  
NO >> Inspection End.

A  
B  
C  
D  
E  
F  
G  
H  
I  
MTC  
K  
L  
M

# TROUBLE DIAGNOSIS

## 11. CHECK FRONT BLOWER MOTOR POWER SUPPLY CIRCUIT FOR SHORT

1. Turn ignition switch OFF.
2. Disconnect front blower motor connector and variable blower control connector.
3. Check continuity between variable blower control harness connector M122 terminal 1 (W/L) and ground.

**1 - Ground.** : **Continuity should not exist.**

OK or NG

OK >> GO TO 12.

NG >> Repair harness or connector.

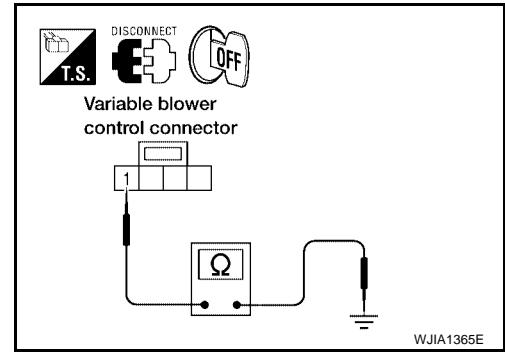

## 12. CHECK VARIABLE BLOWER CONTROL SIGNAL CIRCUIT

1. Disconnect front air control connector.
2. Check continuity between front air control harness connector M49 terminal 40 (G/R) and variable blower control harness connector M122 terminal 2 (G/R).

**40 - 2** : **Continuity should exist.**

OK or NG

OK >> GO TO 13.

NG >> Repair harness or connector.

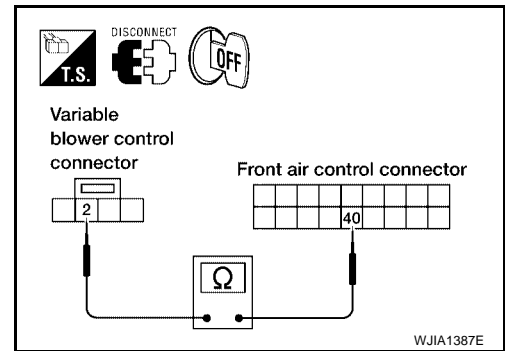

## 13. CHECK FRONT BLOWER MOTOR

Refer to [MTC-97, "BLOWER MOTOR"](#) .

OK or NG

OK >> GO TO 14.

NG >> Replace front blower motor. Refer to [MTC-97, "BLOWER MOTOR"](#) .

## 14. CHECK BLOWER MOTOR GROUND CIRCUIT

Check continuity between front blower motor harness connector M62 terminal 1 (L/W) and variable blower control harness connector M122 terminal 3 (L/W).

**1 - 3** : **Continuity should exist.**

OK or NG

OK >> GO TO 15.

NG >> Repair harness or connector.

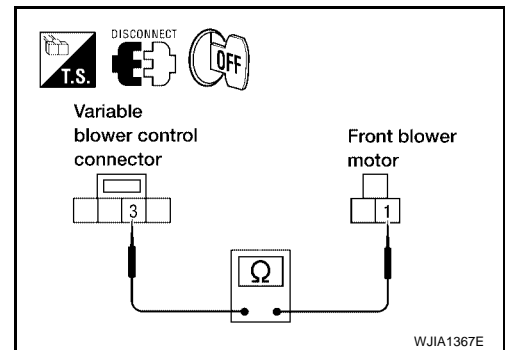



# TROUBLE DIAGNOSIS

## 15. CHECK VARIABLE BLOWER CONTROL GROUND CIRCUIT

Check continuity between variable blower control harness connector M122 terminal 4 (B/W) and ground.

**4 - ground : Continuity should exist.**

OK or NG

- OK >> Replace variable blower control. Refer to [MTC-108](#), "["VARIABLE BLOWER CONTROL"](#) .
- NG >> Repair harness or connector.

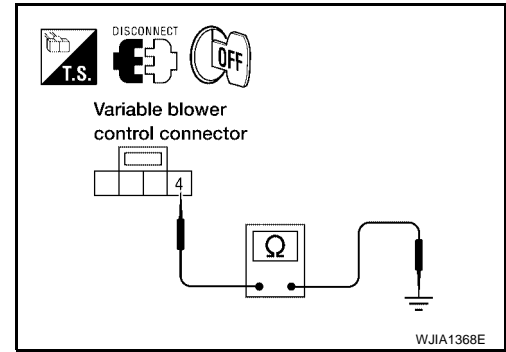

## COMPONENT INSPECTION

### Front Blower Motor Relay

Check continuity between terminals by supplying 12 volts and ground to coil side terminals of relay.

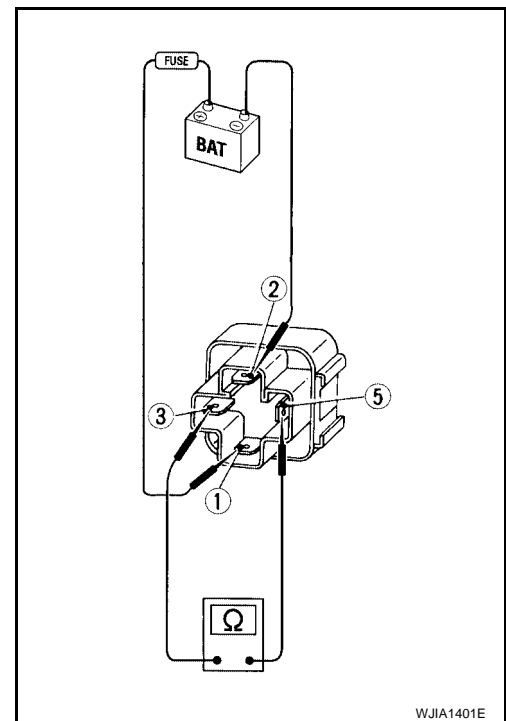

### Front Blower Motor

Confirm smooth rotation of the blower motor.

- Ensure that there are no foreign particles inside the blower unit.
- Apply 12 volts to terminal 1 and ground to terminal 2 and verify that the motor operates freely and quietly.

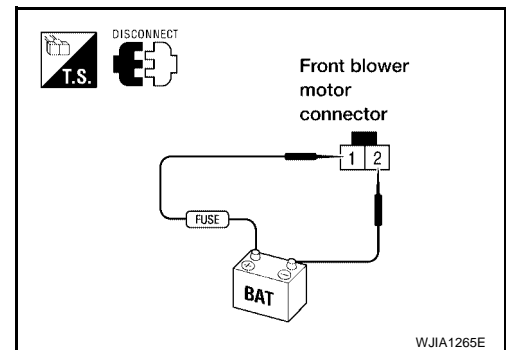

A  
B  
C  
D  
E  
F  
G  
H  
I  
MTC  
K  
L  
M

# TROUBLE DIAGNOSIS

EJS003UD

## Magnet Clutch Circuit

SYMPTOM: Magnet clutch does not engage.

### INSPECTION FLOW

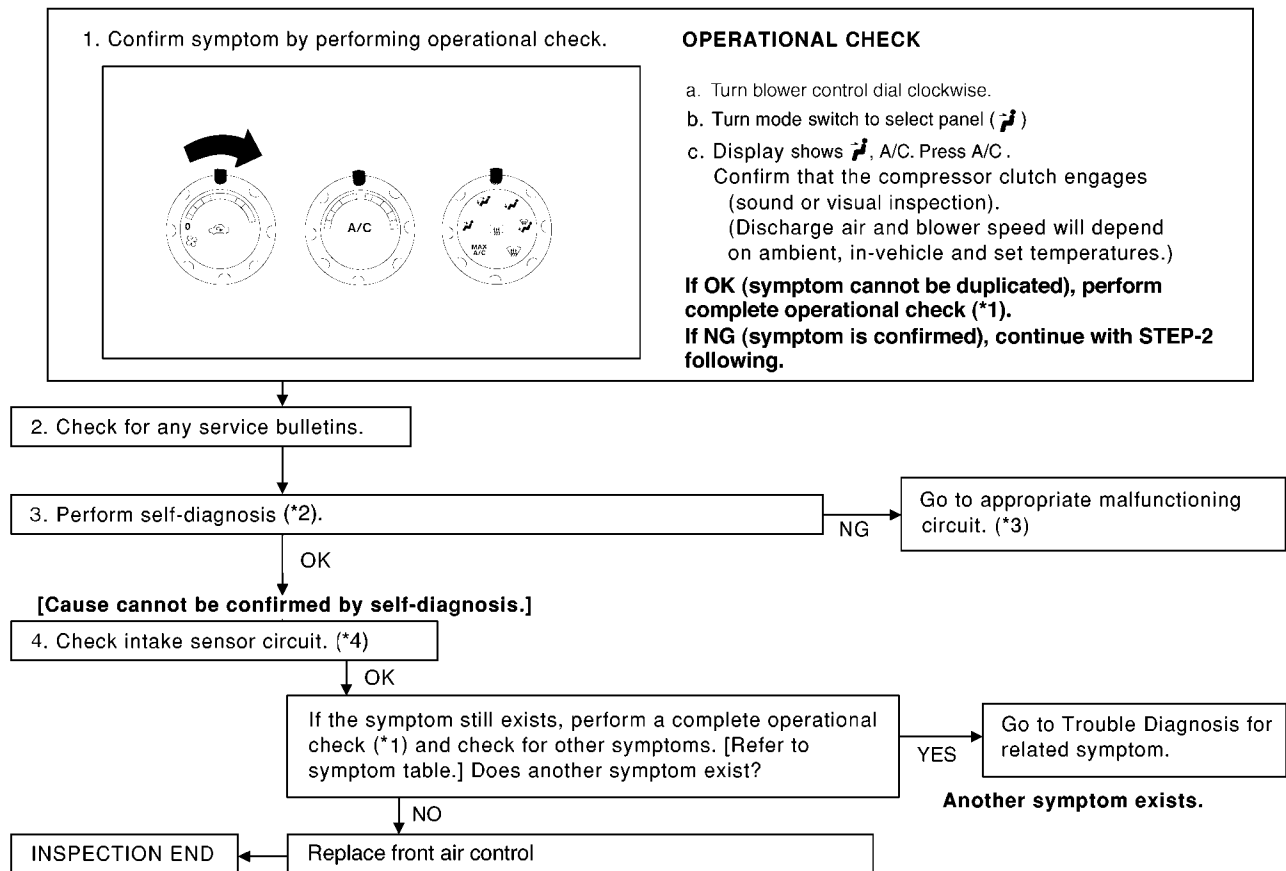

\*1 [MTC-47, "Operational Check"](#).

\*2 [MTC-45, "A/C System Self-diagnosis Function \(With NAVI Only\)"](#).

\*3 [MTC-46, "SELF-DIAGNOSIS CODE CHART"](#).

\*4 [MTC-92, "Intake Sensor Circuit"](#).

WJIA1435E

# TROUBLE DIAGNOSIS

## SYSTEM DESCRIPTION

The front air control controls compressor operation based on ambient and intake temperature and a signal from ECM.

### Low Temperature Protection Control

The front air control will turn the compressor ON or OFF as determined by a signal detected by the intake sensor.

When intake air temperature is higher than the preset value, the compressor turns ON. The compressor turns OFF when intake air temperature is lower than the preset value.

## DIAGNOSTIC PROCEDURE FOR MAGNET CLUTCH

SYMPTOM: Magnet clutch does not engage when A/C switch is ON.

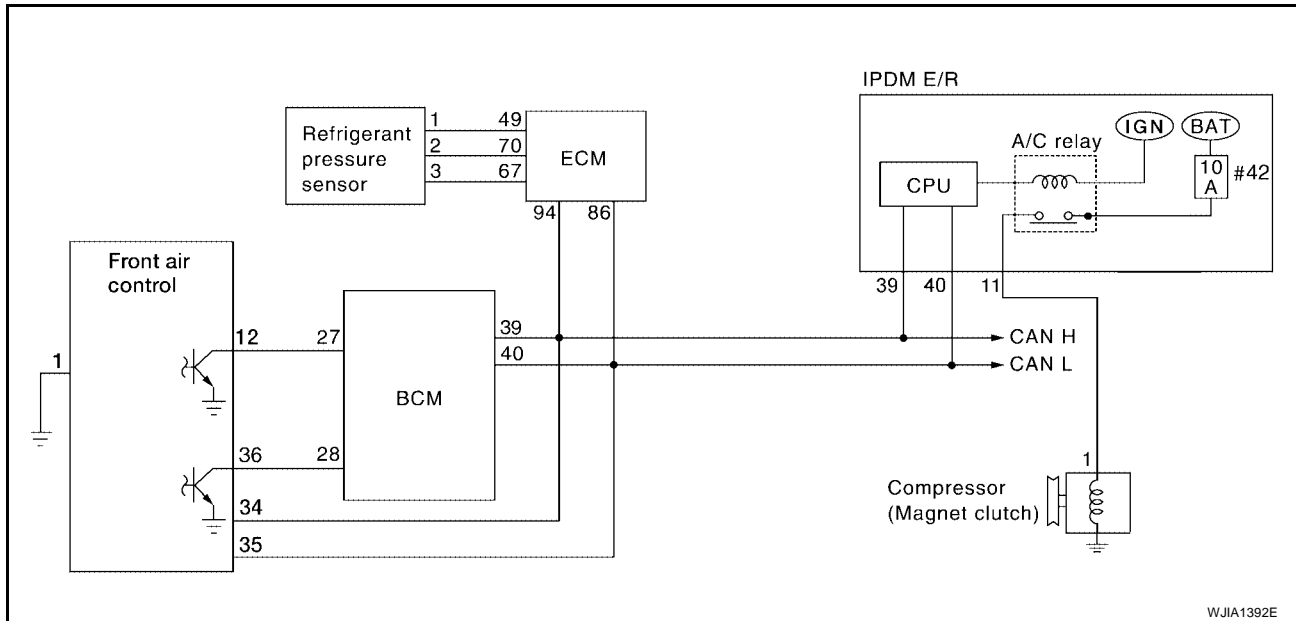

### 1. CHECK INTAKE SENSOR CIRCUITS

Check intake sensor. Refer to [MTC-45, "A/C System Self-diagnosis Function \(With NAVI Only\)"](#).

OK or NG

OK >> GO TO 2.

NG >> Malfunctioning intake sensor. Refer to [MTC-92, "Intake Sensor Circuit"](#).

### 2. PERFORM AUTO ACTIVE TEST

Refer to [PG-22, "Auto Active Test"](#).

Does magnet clutch operate?

YES or NO

YES >> ● WITH CONSULT-II  
GO TO 5.

● WITHOUT CONSULT-II  
GO TO 6.

NO >> Check 10A fuse (No. 42, located in IPDM E/R), and GO TO 3.

# TROUBLE DIAGNOSIS

## 3. CHECK CIRCUIT CONTINUITY BETWEEN IPDM E/R AND COMPRESSOR

1. Turn ignition switch OFF.
2. Disconnect IPDM E/R connector and A/C compressor (magnet clutch) connector.
3. Check continuity between IPDM E/R harness connector E119 terminal 11 (Y/B) and A/C compressor harness connector F3 terminal 1 (Y/B).

**11 - 1 : Continuity should exist.**

OK or NG

- OK >> GO TO 4.  
 NG >> Repair harness or connector.

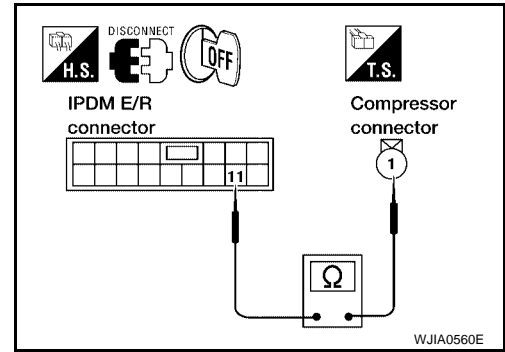

## 4. CHECK MAGNET CLUTCH CIRCUIT

Check for operation sound when applying battery voltage to terminal 1 of A/C compressor.

OK or NG

- OK >> Replace IPDM E/R. Refer to [PG-28, "Removal and Installation of IPDM E/R"](#) .  
 NG >> Replace magnet clutch. Refer to [MTC-116, "Removal and Installation for Compressor Clutch"](#) .

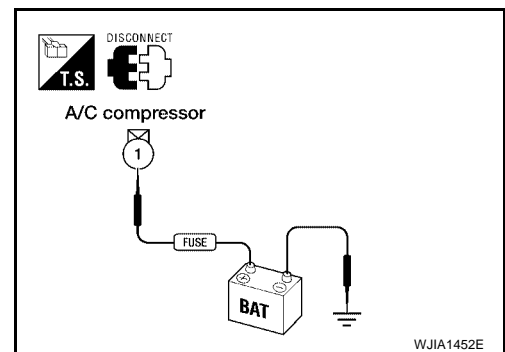

## 5. CHECK BCM INPUT (COMPRESSOR ON) SIGNAL

Check compressor ON/OFF signal. Refer to [MTC-31, "CONSULT-II Function \(BCM\)"](#) .

**A/C SW ON : COMP ON SIG ON**  
**A/C SW OFF : COMP ON SIG OFF**

OK or NG

- OK >> GO TO 8.  
 NG >> GO TO 6.

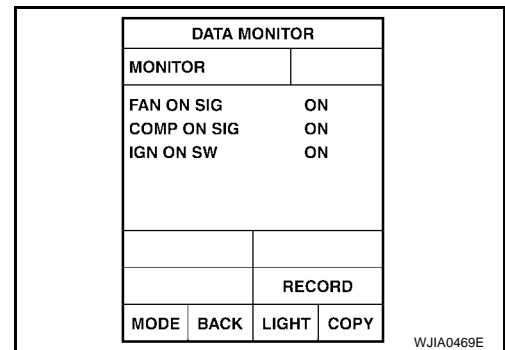

## 6. CHECK CIRCUIT CONTINUITY BETWEEN BCM AND FRONT AIR CONTROL

1. Turn ignition switch OFF.
2. Disconnect BCM connector and front air control connector.
3. Check continuity between BCM harness connector M18 terminal 27 (W/R) and front air control harness connector M49 terminal 12 (W/R).

**27 - 12 Continuity should exist.**

OK or NG

- OK >> GO TO 7.  
 NG >> Repair harness or connector.

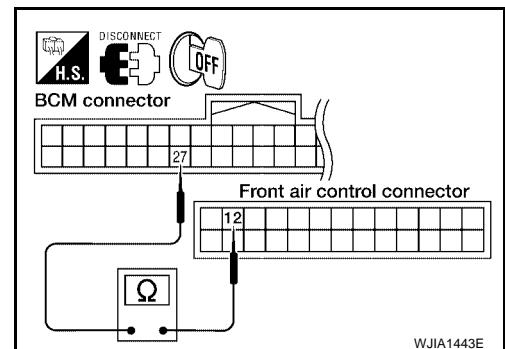

# TROUBLE DIAGNOSIS

## 7. CHECK VOLTAGE FOR FRONT AIR CONTROL (COMPRESSOR ON SIGNAL)

1. Reconnect BCM connector and front air control connector.
2. Turn ignition switch ON.
3. Check voltage between front air control harness connector M49 terminal 12 (W/R) and ground.

Terminals		(-)	Condition	Voltage
(+)				
Front air control connector	Terminal No. (Wire color)			
M49	12 (W/R)	Ground	A/C switch: ON	Approx. 0V
			A/C switch: OFF	Approx. 5V

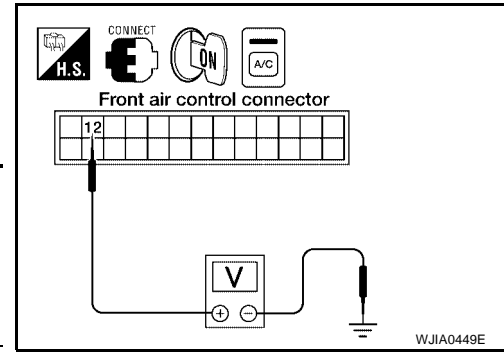

### OK or NG

OK >> GO TO 8.

NG-1 >> If the voltage is approx. 5V when A/C switch is ON, replace front air control. Refer to [MTC-95, "CONTROL UNIT"](#).

NG-2 >> If the voltage is approx. 0V when A/C switch is OFF, replace BCM. Refer to [BCS-19, "Removal and Installation of BCM"](#).

## 8. CHECK REFRIGERANT PRESSURE SENSOR

### Ⓜ WITH CONSULT-II

1. Start engine.
2. Check voltage of refrigerant pressure sensor. Refer to [MTC-28, "CONSULT-II Function \(HVAC\)"](#).

### ⓧ WITHOUT CONSULT-II

1. Start engine.
2. Check voltage between ECM harness connector F54 terminal 70 (B/W) and ground.

Terminals		(-)	Condition	Voltage
(+)				
ECM connector	Terminal No. (Wire color)			
F54	70 (B/W)	Ground	A/C switch: ON	Approx. 0.36 - 3.88V

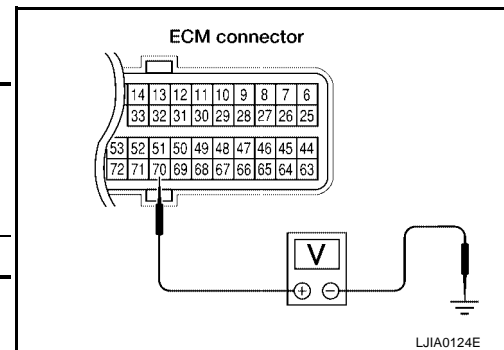

### OK or NG

OK >> ● Ⓜ WITH CONSULT-II  
GO TO 9.

- ⓧ WITHOUT CONSULT-II  
GO TO 10.

NG >> Refer to [EC-620, "REFRIGERANT PRESSURE SENSOR"](#).

# TROUBLE DIAGNOSIS

## 9. CHECK BCM INPUT (FAN ON) SIGNAL

Check FAN ON/OFF signal. Refer to [MTC-31, "CONSULT-II Function \(BCM\)"](#).

**FRONT BLOWER CONTROL : FAN ON SIG ON  
DIAL ON**

**FRONT BLOWER CONTROL : FAN ON SIG OFF  
DIAL OFF**

OK or NG

- OK >> GO TO 12.
- NG >> GO TO 10.

DATA MONITOR			
MONITOR			
FAN ON SIG	ON		
COMP ON SIG	ON		
IGN ON SW	ON		
		RECORD	
MODE	BACK	LIGHT	COPY

WJIA0469E

## 10. CHECK CIRCUIT CONTINUITY BETWEEN BCM AND FRONT AIR CONTROL

- Turn ignition switch OFF.
- Disconnect BCM connector and front air control connector.
- Check continuity between BCM harness connector M18 terminal 28 (L/R) and front air control harness connector M50 terminal 36 (L/R).

**28 - 36 Continuity should exist.**

OK or NG

- OK >> GO TO 11.
- NG >> Repair harness or connector.

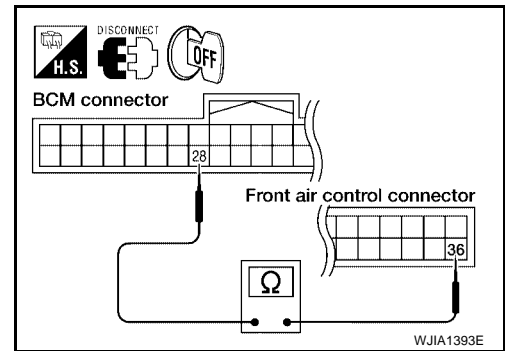

## 11. CHECK VOLTAGE FOR FRONT AIR CONTROL (FAN ON SIGNAL)

- Reconnect BCM connector and front air control connector.
- Turn ignition switch ON.
- Check voltage between front air control harness connector M49 terminal 36 (L/R) and ground.

Terminals		(-)	Condition	Voltage
(+)	Terminal No. (Wire color)			
Front air control connector				
M50	36 (L/R)	Ground	A/C switch: ON Blower motor operates	Approx. 0V
			A/C switch: OFF	Approx. 5V

OK or NG

- OK >> GO TO 12.
- NG-1 >> If the voltage is approx. 5V when blower motor is ON, replace front air control. Refer to [MTC-95, "CONTROL UNIT"](#).
- NG-2 >> If the voltage is approx. 0V when blower motor is OFF, replace BCM. Refer to [BCS-19, "Removal and Installation of BCM"](#).

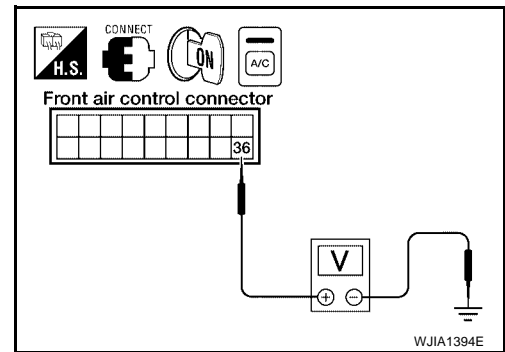

# TROUBLE DIAGNOSIS

## 12. CHECK CAN COMMUNICATION

Check CAN communication. Refer to [LAN-7, "CAN COMMUNICATION"](#) .

- BCM – ECM
- ECM – IPDM E/R
- ECM – Front air control

OK or NG

OK >> Inspection End.

NG >> Repair or replace malfunctioning part(s).

### COMPONENT INSPECTION

#### Refrigerant Pressure Sensor

The refrigerant pressure sensor is attached to the condenser.

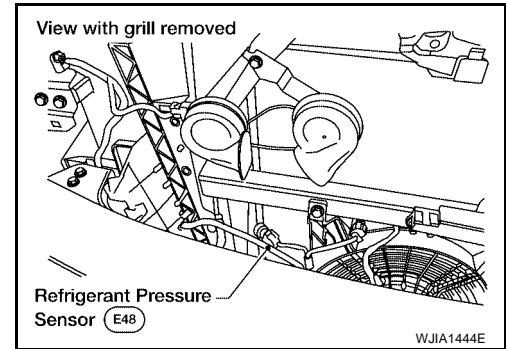

A

B

C

D

E

F

G

H

I

MTC

K

L

M

# TROUBLE DIAGNOSIS

EJS003UE

## Insufficient Cooling

SYMPTOM: Insufficient cooling

### INSPECTION FLOW

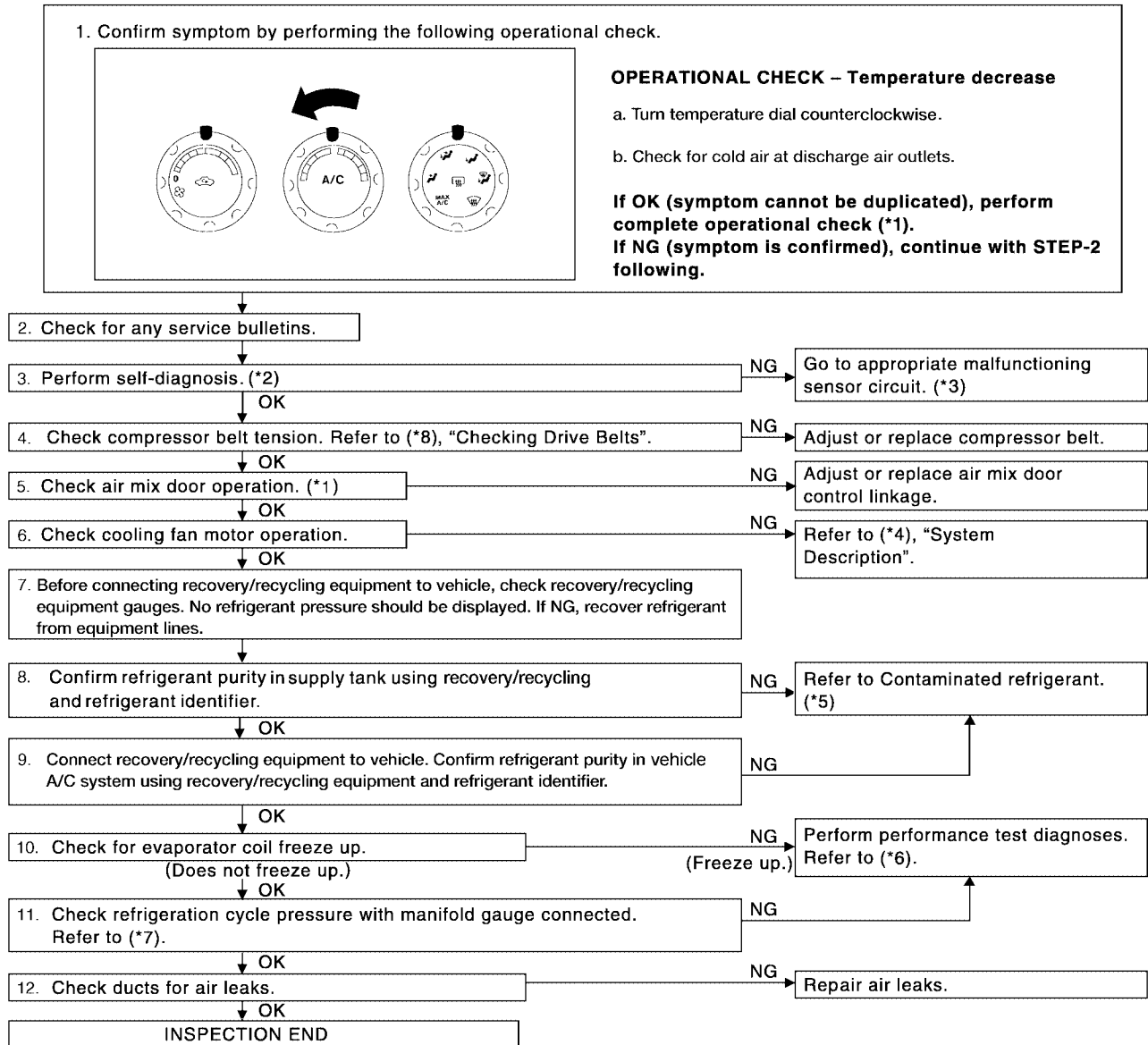

\*1 [.MTC-47, "Operational Check"](#) .

\*2 [MTC-45, "A/C System Self-diagnosis Function \(With NAVI Only\)"](#).

\*3 [MTC-46, "SELF-DIAGNOSIS CODE CHART"](#).

\*4 [EC-436, "DTC P1217 ENGINE OVER TEMPERATURE"](#) .

\*5 [MTC-4, "Contaminated Refrigerant"](#).

\*6 [.MTC-81, "PERFORMANCE TEST DIAGNOSES"](#)

\*7 [MTC-83, "Test Reading"](#)

\*8 [EM-12, "Checking Drive Belts"](#)

WJIA1436E



# TROUBLE DIAGNOSIS

## PERFORMANCE TEST DIAGNOSES

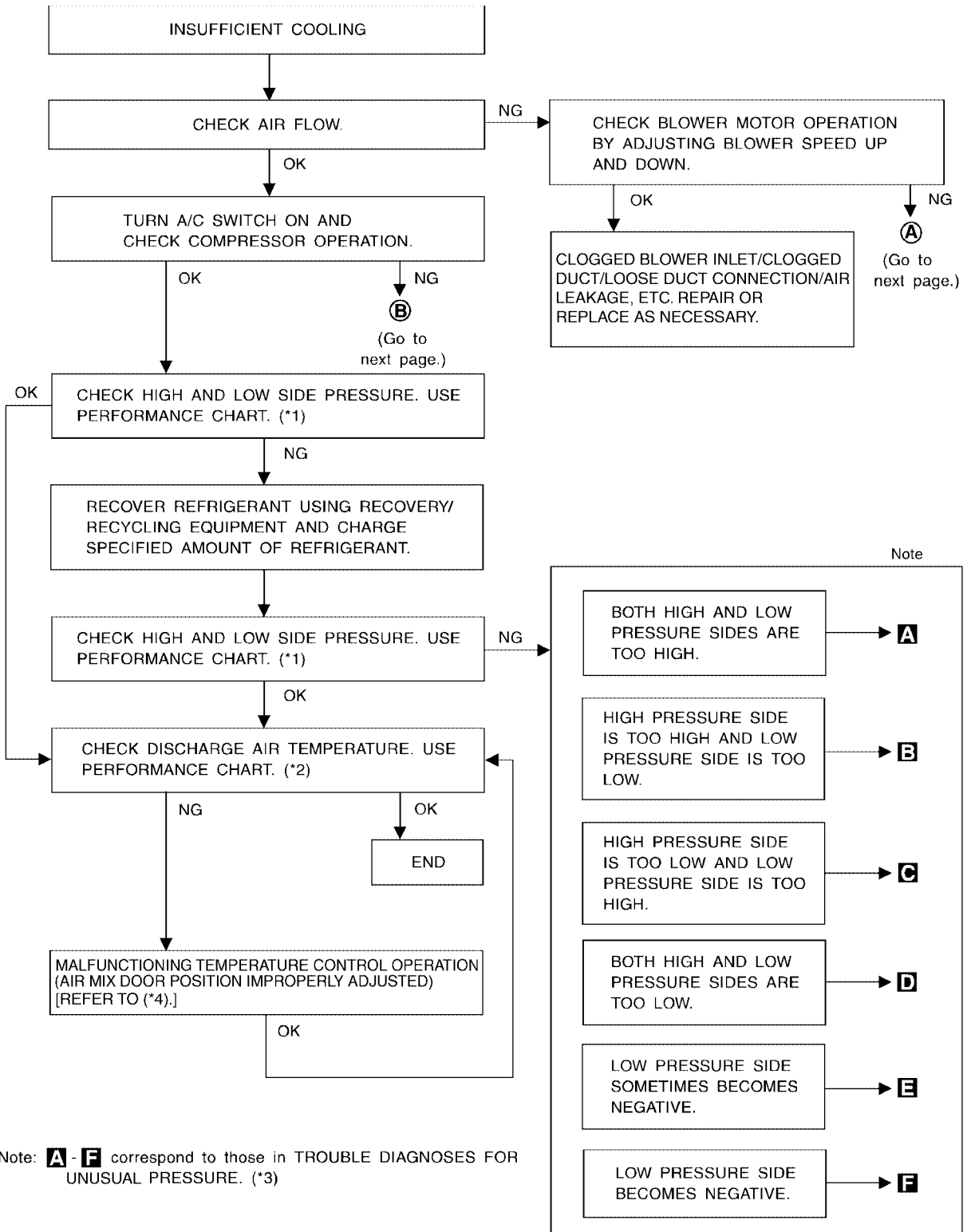

\*1 [MTC-83, "PERFORMANCE CHART"](#).

\*2 [MTC-83, "PERFORMANCE CHART"](#).

\*3 [MTC-84, "Trouble Diagnoses for Unusual Pressure"](#).

\*4 [MTC-56, "Air Mix Door Motor Circuit"](#).

WJIA0533E

# TROUBLE DIAGNOSIS

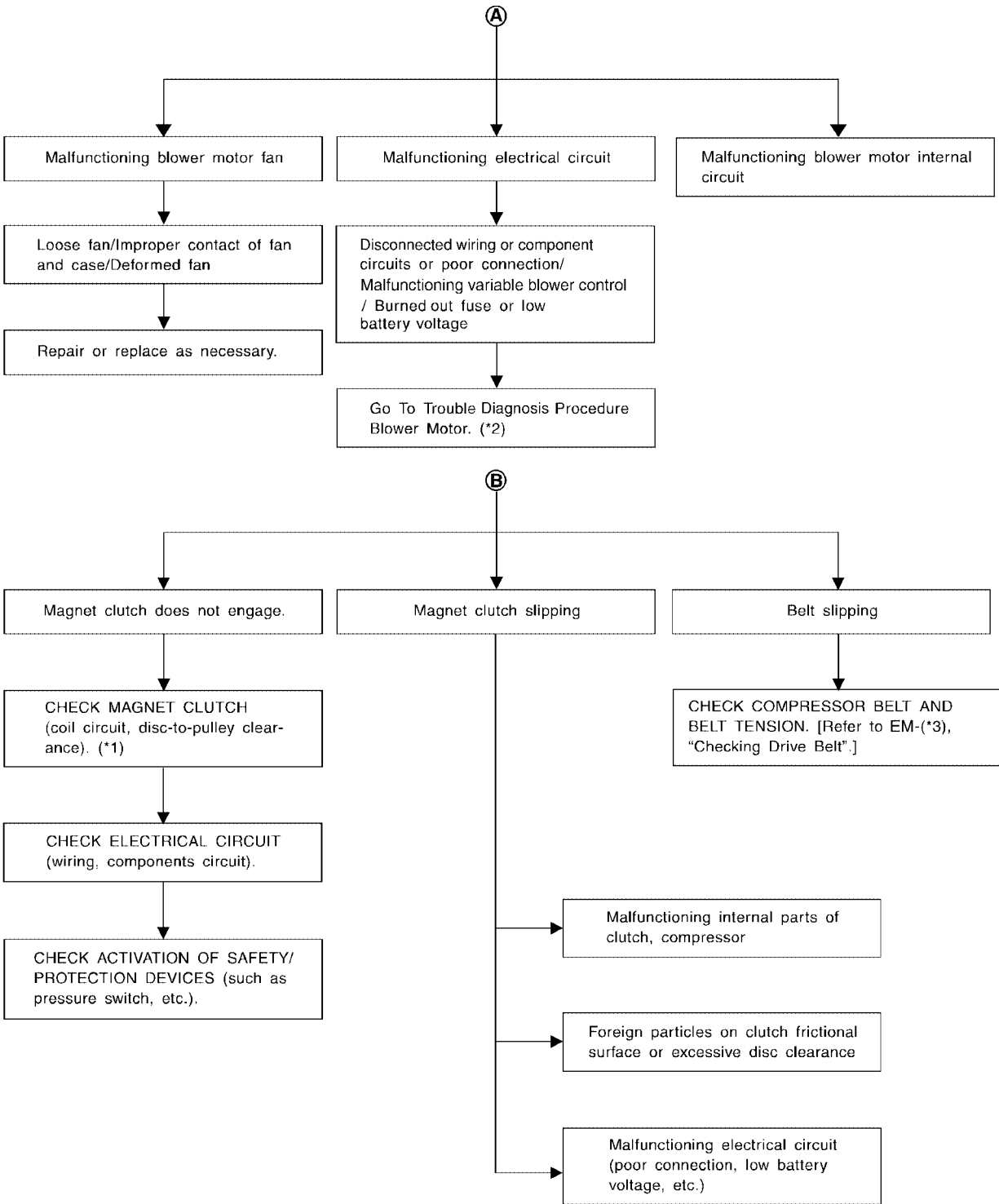

WJIA1371E

\*1 [MTC-116. "Removal and Installation for Compressor Clutch".](#)

\*2 [MTC-67. "Front Blower Motor Circuit".](#)



\*3 [EM-12. "Checking Drive Belts".](#)

# TROUBLE DIAGNOSIS

## PERFORMANCE CHART

### Test Condition

Testing must be performed as follows:

Vehicle location	Indoors or in the shade (in a well-ventilated place)
Doors	Closed
Door window	Open
Hood	Open
TEMP.	Max. COLD
Mode switch	 (Ventilation) set
Recirculation (REC) switch	 (Recirculation) set
 Blower speed	Max. speed set
Engine speed	Idle speed

Operate the air conditioning system for 10 minutes before taking measurements.

### Test Reading

#### Recirculating-to-discharge Air Temperature Table

Inside air (Recirculating air) at blower assembly inlet		Discharge air temperature at center ventilator °C (°F)
Relative humidity %	Air temperature °C (°F)	
50 - 60	20 (68)	5.3 - 6.5 (42 - 44)
	25 (77)	9.7 - 11.5 (49 - 53)
	30 (86)	13.8 - 16.3 (57 - 61)
	35 (95)	18.0 - 21.2 (64 - 70)
	40 (104)	22.2 - 25.7 (72 - 78)
60 - 70	20 (68)	6.5 - 7.7 (44 - 46)
	25 (77)	11.5 - 13.3 (53 - 56)
	30 (86)	16.3 - 18.8 (61 - 66)
	35 (95)	21.2 - 24.0 (70 - 75)
	40 (104)	25.7 - 29.2 (78 - 85)

#### Ambient Air Temperature-to-operating Pressure Table

Ambient air		High-pressure (Discharge side) kPa (kg/cm <sup>2</sup> , psi)	Low-pressure (Suction side) kPa (kg/cm <sup>2</sup> , psi)
Relative humidity %	Air temperature °C (°F)		
50 - 70	20 (68)	680 - 840 (6.94 - 8.57, 98.6 - 121.8)	160 - 198 (1.63 - 2.02, 23.2 - 28.7)
	25 (77)	800 - 985 (8.16 - 10.05, 116.0 - 142.8)	198 - 245 (2.02 - 2.50, 28.7 - 35.5)
	30 (86)	940 - 1,150 (9.59 - 11.73, 136.3 - 166.8)	225 - 278 (2.30 - 2.84, 32.6 - 40.3)
	35 (95)	1,160 - 1,410 (11.83 - 14.38, 168.2 - 204.5)	273 - 335 (2.78 - 3.42, 39.6 - 48.6)
	40 (104)	1,325 - 1,620 (13.52 - 16.52, 192.1 - 234.9)	325 - 398 (3.32 - 4.06, 47.1 - 57.7)

# TROUBLE DIAGNOSIS

## TROUBLE DIAGNOSES FOR UNUSUAL PRESSURE

Whenever system's high and/or low side pressure is unusual, diagnose using a manifold gauge. The marker above the gauge scale in the following tables indicates the standard (usual) pressure range. Since the standard (usual) pressure, however, differs from vehicle to vehicle, refer to above table (Ambient air temperature-to-operating pressure table).

### Both High- and Low-pressure Sides are Too High

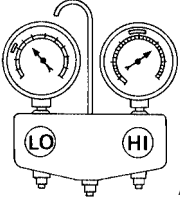
Gauge indication	Refrigerant cycle	Probable cause	Corrective action
<p>Both high- and low-pressure sides are too high.</p>  <p style="text-align: right; font-size: small;">AC359A</p>	Pressure is reduced soon after water is splashed on condenser.	Excessive refrigerant charge in refrigeration cycle	Reduce refrigerant until specified pressure is obtained.
	Air suction by cooling fan is insufficient.	Insufficient condenser cooling performance ↓ 1. Condenser fins are clogged. 2. Improper fan rotation of cooling fan	<ul style="list-style-type: none"> <li>● Clean condenser.</li> <li>● Check and repair cooling fan if necessary.</li> </ul>
	<ul style="list-style-type: none"> <li>● Low-pressure pipe is not cold.</li> <li>● When compressor is stopped high-pressure value quickly drops by approximately 196 kPa (2 kg/cm<sup>2</sup>, 28 psi). It then decreases gradually thereafter.</li> </ul>	Poor heat exchange in condenser (After compressor operation stops, high-pressure decreases too slowly.) ↓ Air in refrigeration cycle	Evacuate repeatedly and recharge system.
	Engine tends to overheat.	Engine cooling systems malfunction.	Check and repair engine cooling system.
	<ul style="list-style-type: none"> <li>● An area of the low-pressure pipe is colder than areas near the evaporator outlet.</li> <li>● Plates are sometimes covered with frost.</li> </ul>	<ul style="list-style-type: none"> <li>● Excessive liquid refrigerant on low-pressure side</li> <li>● Excessive refrigerant discharge flow</li> <li>● Expansion valve is open a little compared with the specification.</li> </ul> ↓ Improper expansion valve adjustment	Replace expansion valve.

### High-pressure Side is Too High and Low-pressure Side is Too Low

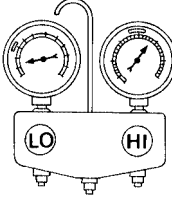
Gauge indication	Refrigerant cycle	Probable cause	Corrective action
<p>High-pressure side is too high and low-pressure side is too low.</p>  <p style="text-align: right; font-size: small;">AC360A</p>	Upper side of condenser and high-pressure side are hot, however, liquid tank is not so hot.	High-pressure tube or parts located between compressor and condenser are clogged or crushed.	<ul style="list-style-type: none"> <li>● Check and repair or replace malfunctioning parts.</li> <li>● Check lubricant for contamination.</li> </ul>

# TROUBLE DIAGNOSIS

## High-pressure Side is Too Low and Low-pressure Side is Too High

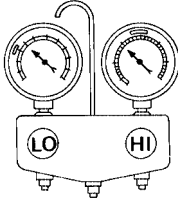
Gauge indication	Refrigerant cycle	Probable cause	Corrective action
High-pressure side is too low and low-pressure side is too high.  AC356A	High- and low-pressure sides become equal soon after compressor operation stops.	Compressor pressure operation is improper. ↓ Damaged inside compressor packings.	Replace compressor.
	No temperature difference between high- and low-pressure sides.	Compressor pressure operation is improper. ↓ Damaged inside compressor packings.	Replace compressor.

## Both High- and Low-pressure Sides are Too Low

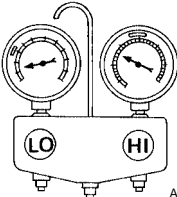
Gauge indication	Refrigerant cycle	Probable cause	Corrective action
Both high- and low-pressure sides are too low.  AC353A	<ul style="list-style-type: none"> <li>There is a big temperature difference between liquid tank outlet and inlet. Outlet temperature is extremely low.</li> <li>Liquid tank inlet and expansion valve are frosted.</li> </ul>	Liquid tank inside is slightly clogged.	<ul style="list-style-type: none"> <li>Replace liquid tank.</li> <li>Check lubricant for contamination.</li> </ul>
	<ul style="list-style-type: none"> <li>Temperature of expansion valve inlet is extremely low as compared with areas near liquid tank.</li> <li>Expansion valve inlet may be frosted.</li> <li>Temperature difference occurs somewhere in high-pressure side.</li> </ul>	High-pressure pipe located between liquid tank and expansion valve is clogged.	<ul style="list-style-type: none"> <li>Check and repair malfunctioning parts.</li> <li>Check lubricant for contamination.</li> </ul>
	Expansion valve and liquid tank are warm or only cool when touched.	Low refrigerant charge. ↓ Leaking fittings or components.	Check refrigerant system for leaks. Refer to <a href="#">MTC-123</a> , " <a href="#">Checking for Refrigerant Leaks</a> ".
	There is a big temperature difference between expansion valve inlet and outlet while the valve itself is frosted.	Expansion valve closes a little compared with the specification. ↓ 1. Improper expansion valve adjustment. 2. Malfunctioning expansion valve. 3. Outlet and inlet may be clogged.	<ul style="list-style-type: none"> <li>Remove foreign particles by using compressed air.</li> <li>Check lubricant for contamination.</li> </ul>
	An area of the low-pressure pipe is colder than areas near the evaporator outlet.	Low-pressure pipe is clogged or crushed.	<ul style="list-style-type: none"> <li>Check and repair malfunctioning parts.</li> <li>Check lubricant for contamination.</li> </ul>
	Air flow volume is too low.	Evaporator is frozen.	<ul style="list-style-type: none"> <li>Check intake sensor circuit. Refer to <a href="#">MTC-92</a>, "<a href="#">Intake Sensor Circuit</a>".</li> <li>Repair evaporator fins.</li> <li>Replace evaporator.</li> <li>Refer to <a href="#">MTC-67</a>, "<a href="#">Front Blower Motor Circuit</a>".</li> </ul>

# TROUBLE DIAGNOSIS

## Low-pressure Side Sometimes Becomes Negative

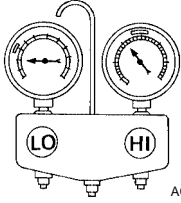
Gauge indication	Refrigerant cycle	Probable cause	Corrective action
<p>Low-pressure side sometimes becomes negative.</p>  <p style="text-align: right; font-size: small;">AC354A</p>	<ul style="list-style-type: none"> <li>● Air conditioning system does not function and does not cyclically cool the compartment air.</li> <li>● The system constantly functions for a certain period of time after compressor is stopped and restarted.</li> </ul>	<p>Refrigerant does not discharge cyclically.</p> <p>↓</p> <p>Moisture is frozen at expansion valve outlet and inlet.</p> <p>↓</p> <p>Water is mixed with refrigerant.</p>	<ul style="list-style-type: none"> <li>● Drain water from refrigerant or replace refrigerant.</li> <li>● Replace liquid tank.</li> </ul>

## Low-pressure Side Becomes Negative

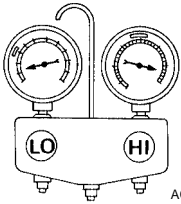
Gauge indication	Refrigerant cycle	Probable cause	Corrective action
<p>Low-pressure side becomes negative.</p>  <p style="text-align: right; font-size: small;">AC362A</p>	<p>Liquid tank or front/rear side of expansion valve's pipe is frosted or dewed.</p>	<p>High-pressure side is closed and refrigerant does not flow.</p> <p>↓</p> <p>Expansion valve or liquid tank is frosted.</p>	<p>Leave the system at rest until no frost is present. Start it again to check whether or not the malfunction is caused by water or foreign particles.</p> <ul style="list-style-type: none"> <li>● If water is the cause, initially cooling is okay. Then the water freezes causing a blockage. Drain water from refrigerant or replace refrigerant.</li> <li>● If due to foreign particles, remove expansion valve and remove the particles with dry and compressed air (not shop air).</li> <li>● If either of the above methods cannot correct the malfunction, replace expansion valve.</li> <li>● Replace liquid tank.</li> <li>● Check lubricant for contamination.</li> </ul>

# TROUBLE DIAGNOSIS

EJS003UF

## Insufficient Heating

SYMPTOM: Insufficient heating

### INSPECTION FLOW

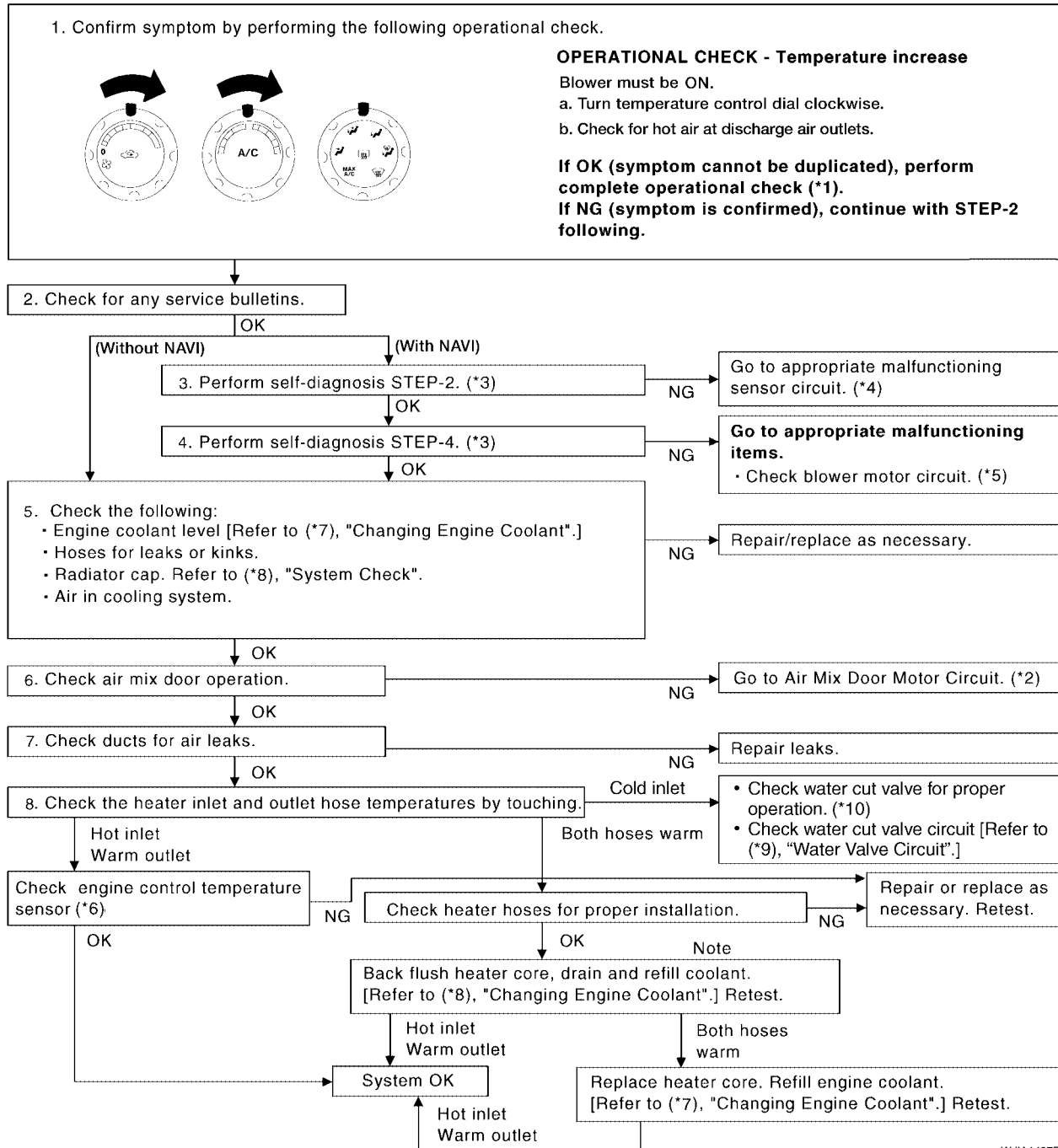

WJIA1437E

\*1 [.MTC-47, "Operational Check"](#)

\*2 [MTC-56, "Air Mix Door Motor Circuit"](#).

\*3 [MTC-45, "A/C System Self-diagnosis Function \(With NAVI Only\)"](#).

\*4 [MTC-46, "SELF-DIAGNOSIS CODE CHART"](#).

\*5 [MTC-67, "Front Blower Motor Circuit"](#).

\*6 [EC-192, "DTC P0117, P0118 ECT SENSOR"](#).

\*7 [CO-10, "Changing Engine Coolant"](#).

\*8 [CO-11, "REFILLING ENGINE COOLANT"](#).

\*9 [MTC-90, "Water Valve Circuit"](#)

\*10 [CO-6, "OVERHEATING CAUSE ANALYSIS"](#)

# TROUBLE DIAGNOSIS

EJS003UG

## Noise

SYMPTOM: Noise

### INSPECTION FLOW

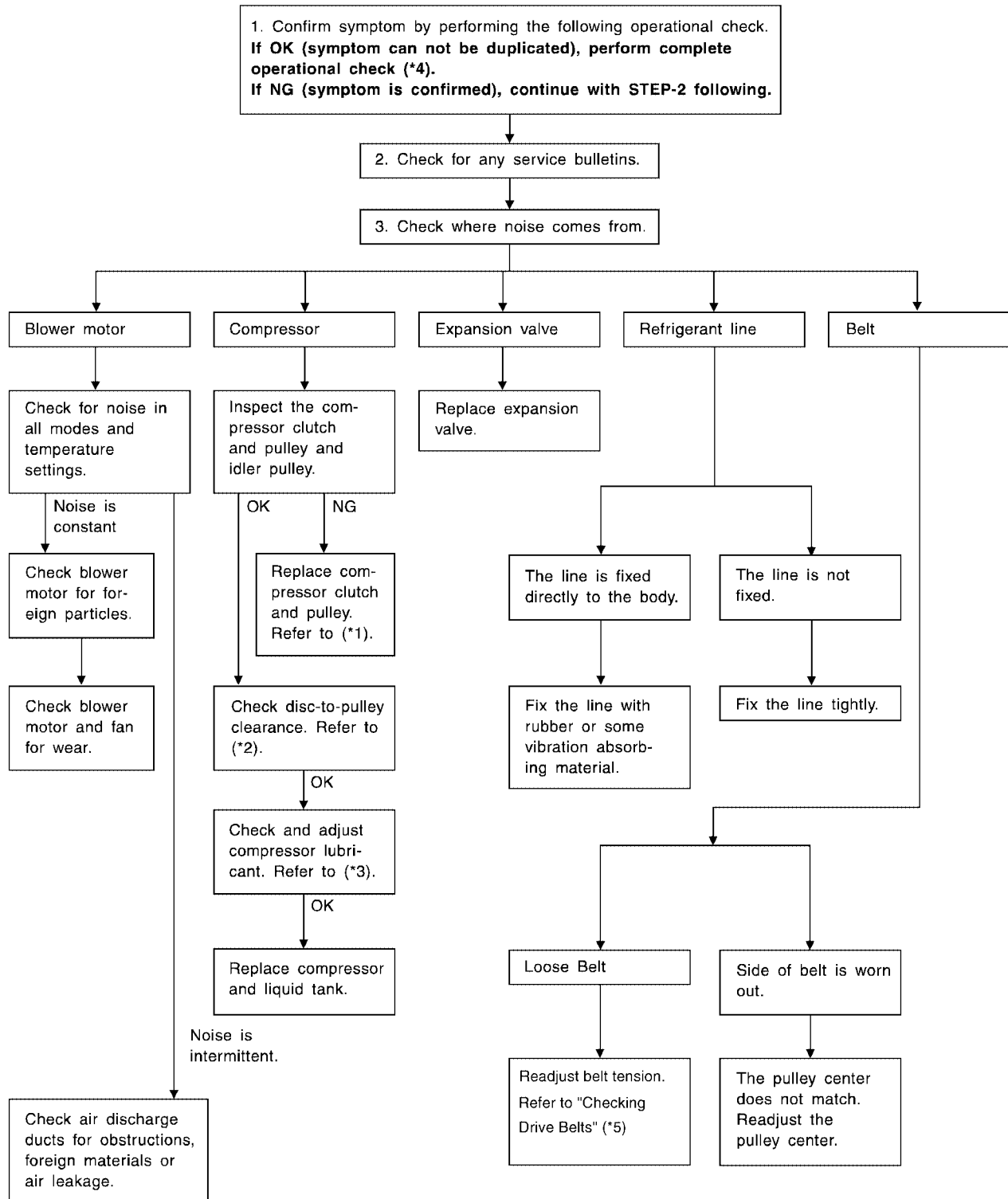

WJIA0473E

\*1 [MTC-116, "Removal and Installation for Compressor Clutch".](#)

\*2 [MTC-117, "Clutch Disc".](#)

\*3 [MTC-20, "Maintenance of Lubricant Quantity in Compressor".](#)

\*4 [MTC-47, "Operational Check".](#)

\*5 [EM-12, "Checking Drive Belts".](#)



# TROUBLE DIAGNOSIS

EJS003UH

## Self-diagnosis

SYMPTOM: Self-diagnosis cannot be performed.

### INSPECTION FLOW

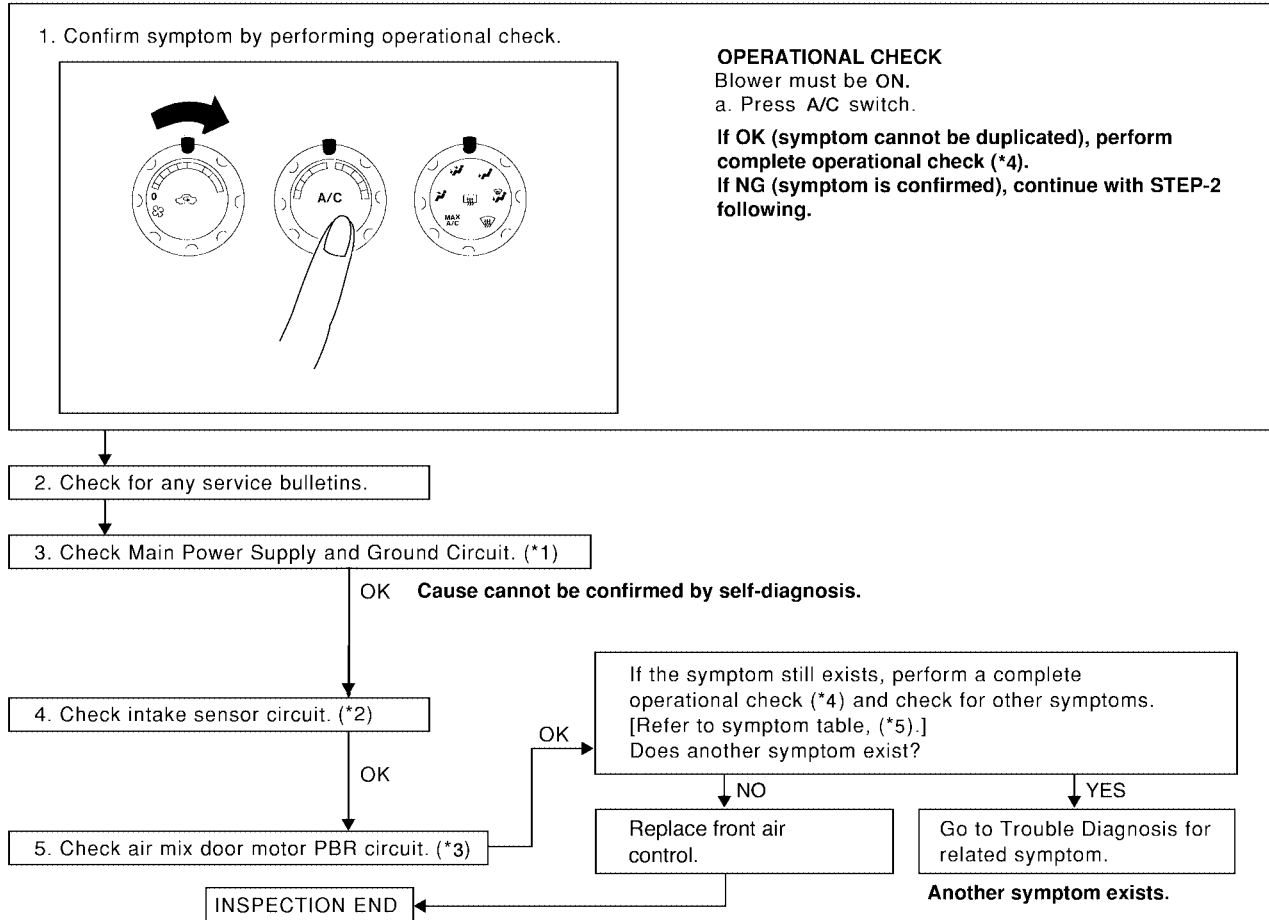

\*1 [MTC-49, "Power Supply and Ground Circuit for Front Air Control"](#).

\*2 [MTC-92, "Intake Sensor Circuit"](#).

\*3 [MTC-56, "Air Mix Door Motor Circuit"](#).

\*4 [MTC-47, "Operational Check"](#).

\*5 [MTC-33, "SYMPTOM TABLE"](#).

WJIA1438E

# TROUBLE DIAGNOSIS

EJS003UI

## Water Valve Circuit COMPONENT DESCRIPTION

### Water Valve

The water valve cuts the flow of engine coolant to the front heater cores to allow for maximum cooling during A/C operation. It is controlled by the front air control through the water valve relay.

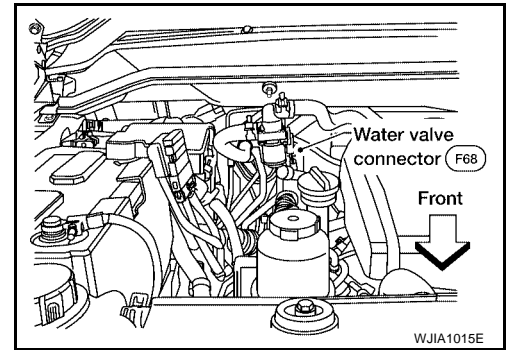

## DIAGNOSTIC PROCEDURE FOR WATER VALVE

### 1. CHECK WATER VALVE RELAY POWER INPUT CIRCUITS

1. Turn ignition switch OFF.
2. Disconnect water valve relay connector M7.
3. Check voltage between water valve relay harness connector terminals and ground.

Terminals		(-)	Ignition switch position	
(+) (Water valve relay connector)			OFF	ON
M7	2 (Y/R)	Ground	Battery voltage	Battery voltage
	3 (Y/G)		0V	Battery voltage

#### OK or NG

- OK >> GO TO 2.  
NG >> Repair harness or connector.

### 2. CHECK WATER VALVE CONTROL

1. Turn ignition switch ON.
2. Select MAX A/C with mode switch.
3. Check continuity between water valve relay harness connector M7 terminal 1 (W/G) and ground, as MAX A/C is switched OFF and ON.

Terminals		(-)	Condition	Continuity
(+) (Water valve relay connector)				
M7	1 (W/G)	Ground	MAX A/C: ON	Yes
			MAX A/C: OFF	No

#### OK or NG

- OK >> GO TO 4.  
NG >> GO TO 3.

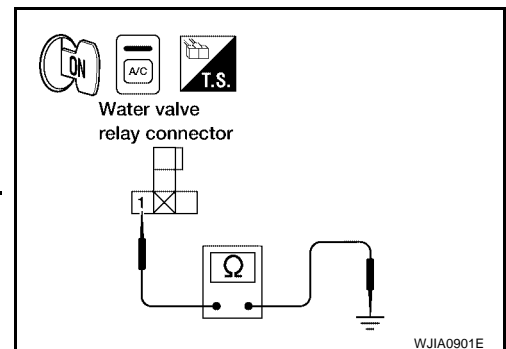
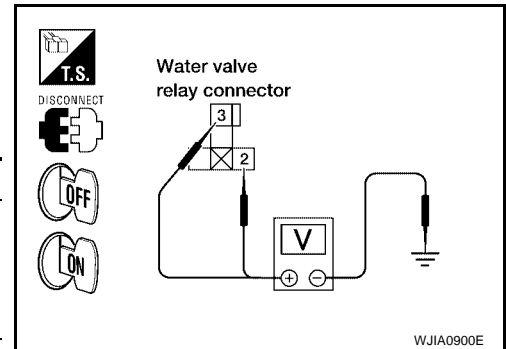

# TROUBLE DIAGNOSIS

## 3. CHECK WATER VALVE CONTROL OUTPUT CIRCUIT

1. Turn ignition switch OFF.
2. Disconnect front air control connector M49.
3. Check continuity between water valve relay harness connector M7 terminal 1 (W/G) and front air control harness connector M49 terminal 10 (W/G).

**1 - 10 : Continuity should exist.**

4. Check continuity between water valve relay harness connector M7 terminal 1 (W/G) and ground.

**1 - Ground : Continuity should not exist.**

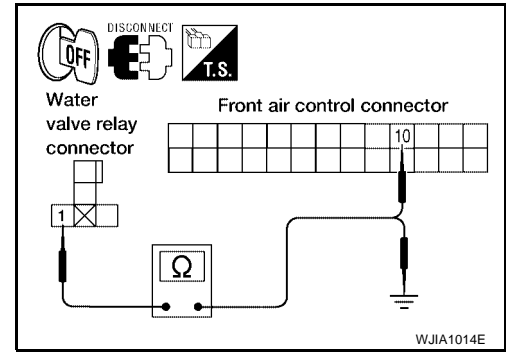

OK or NG

- OK >> Replace front air control. Refer to [MTC-95, "CONTROL UNIT"](#).
- NG >> Repair harness or connector.

## 4. CHECK WATER VALVE RELAY

Check water valve relay. Refer to [MTC-92, "Water Valve Relay"](#).

OK or NG

- OK >> GO TO 5.
- NG >> Replace water valve relay.

## 5. CHECK WATER VALVE GROUND CIRCUIT

1. Turn ignition switch OFF.
2. Disconnect water valve connector F68.
3. Check continuity between water valve harness connector F68 terminal - (B) and ground.

**(-) - Ground : Continuity should exist.**

OK or NG

- OK >> GO TO 6.
- NG >> Repair harness or connector.

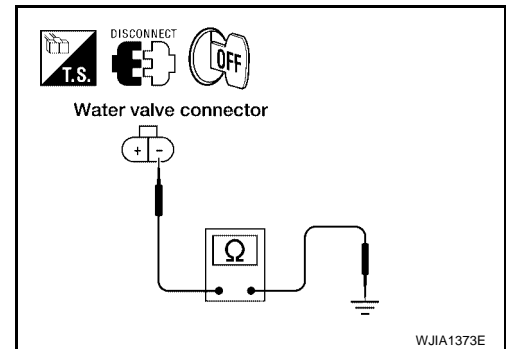

## 6. CHECK WATER VALVE POWER CIRCUIT

1. Check continuity between water valve relay connector M7 terminal 5 (Y/L) and water valve connector F68 terminal + (Y/L)

**5 - (+) : Continuity should exist.**

2. Check continuity between water valve relay harness connector M7 terminal 5 (Y/L) and ground.

**5 - Ground : Continuity should not exist.**

OK or NG

- OK >> Replace water valve.
- NG >> Repair harness or connector.

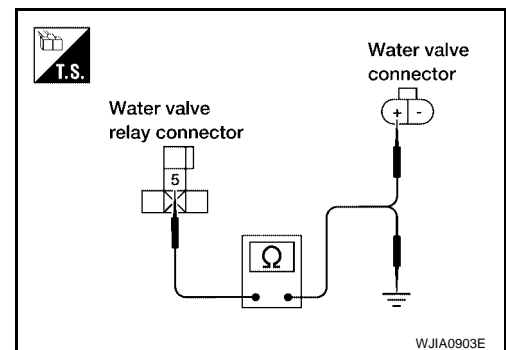

# TROUBLE DIAGNOSIS

## COMPONENT INSPECTION

### Water Valve Relay

Check continuity between terminals by supplying 12 volts and ground to coil side terminals of relay.

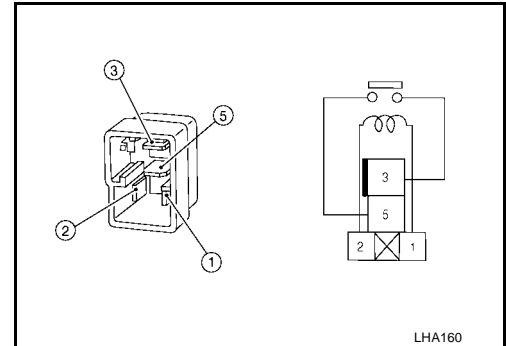

LHA160

EJS003UJ

## Intake Sensor Circuit COMPONENT DESCRIPTION

### Intake Sensor

The intake sensor is located on the heater & cooling unit. It converts temperature of air after it passes through the evaporator into a resistance value which is then input to the front air control.

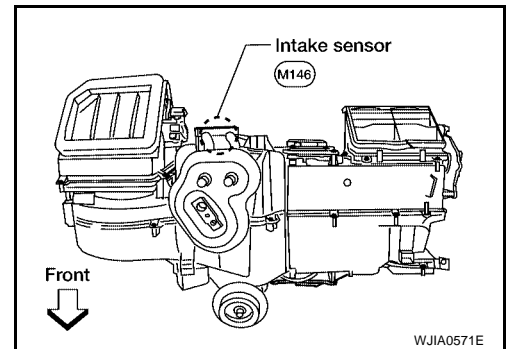

WJIA0571E

## DIAGNOSTIC PROCEDURE FOR INTAKE SENSOR

SYMPTOM: Intake sensor circuit is open or shorted. (56, 57 or DTC B2581, B2582 is indicated on front air control as a result of conducting Self-diagnosis).

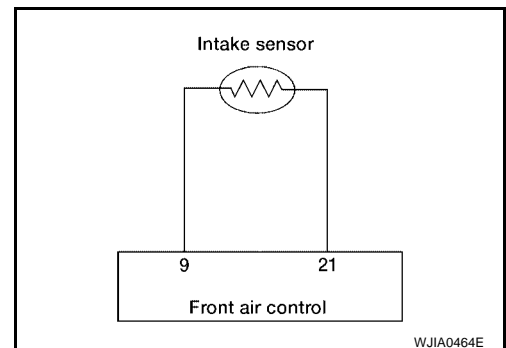

WJIA0464E

## 1. CHECK VOLTAGE BETWEEN INTAKE SENSOR AND GROUND

1. Disconnect intake sensor connector.
2. Turn ignition switch ON.
3. Check voltage between intake sensor harness connector M146 terminal 2 (L/B) and ground.

**2 - Ground**

**: Approx. 5V**

OK or NG

OK >> GO TO 2.

NG >> GO TO 4.

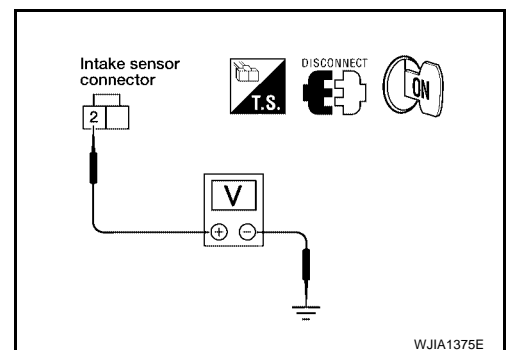

WJIA1375E

# TROUBLE DIAGNOSIS

## 2. CHECK CIRCUIT CONTINUITY BETWEEN INTAKE SENSOR AND FRONT AIR CONTROL

1. Turn ignition switch OFF.
2. Disconnect front air control connector.
3. Check continuity between intake sensor harness connector M146 terminal 1 (V/R) and front air control harness connector M49 terminal 21 (V/R).

**1 - 21** : Continuity should exist.

OK or NG

- OK >> GO TO 3.  
NG >> Repair harness or connector.

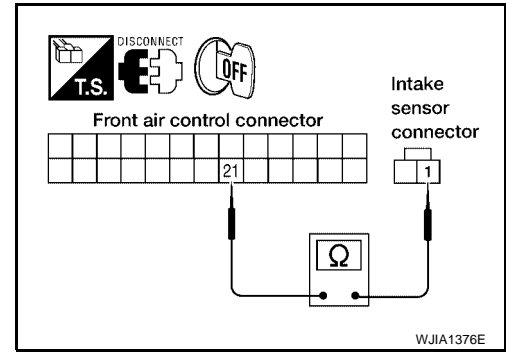

## 3. CHECK INTAKE SENSOR

Refer to [MTC-92, "Intake Sensor Circuit"](#) .

OK or NG

- OK >> 1. Replace front air control. Refer to [MTC-95, "CONTROL UNIT"](#) .  
2. Go to self-diagnosis [MTC-45, "A/C System Self-diagnosis Function \(With NAVI Only\)"](#) and perform self-diagnosis.
- NG >> 1. Replace intake sensor. Refer to [MTC-96, "INTAKE SENSOR"](#) .  
2. Go to self-diagnosis [MTC-45, "A/C System Self-diagnosis Function \(With NAVI Only\)"](#) and perform self-diagnosis.

## 4. CHECK CIRCUIT CONTINUITY BETWEEN INTAKE SENSOR AND FRONT AIR CONTROL

1. Turn ignition switch OFF.
2. Disconnect front air control connector.
3. Check continuity between intake sensor harness connector M146 terminal 2 (L/B) and front air control harness connector M49 terminal 9 (L/B).

**2 - 9** : Continuity should exist.

4. Check continuity between intake sensor harness connector M146 terminal 2 (L/B) and ground.

**2 - Ground** : Continuity should not exist.

OK or NG

- OK >> 1. Replace front air control. Refer to [MTC-95, "CONTROL UNIT"](#) .  
2. Go to self-diagnosis [MTC-45, "A/C System Self-diagnosis Function \(With NAVI Only\)"](#) and perform self-diagnosis.
- NG >> Repair harness or connector.

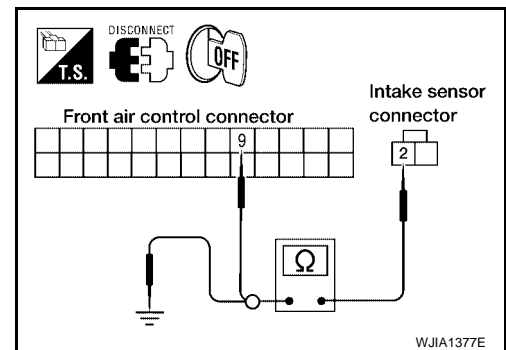

# TROUBLE DIAGNOSIS

## COMPONENT INSPECTION

### Intake Sensor

After disconnecting intake sensor connector, measure resistance between terminals 1 and 2 at sensor harness side, using the table below.

Temperature °C (°F)	Resistance kΩ
-15 (5)	209.0
-10 (14)	160.0
-5 (23)	123.0
0 (32)	95.8
5 (41)	74.9
10 (50)	58.9
15 (59)	46.7
20 (68)	37.3
25 (77)	30.0
30 (86)	24.2
35 (95)	19.7
40 (104)	16.1
45 (113)	13.2

If NG, replace intake sensor.

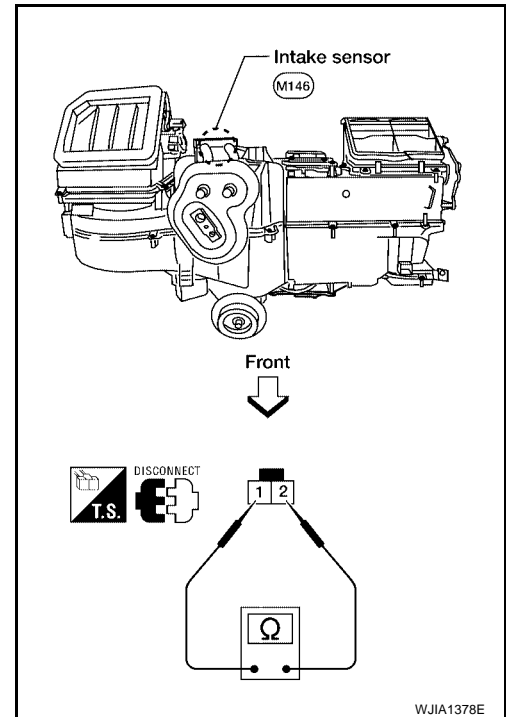

# CONTROL UNIT

## CONTROL UNIT

PFP:27500

EJS0032V

### Removal and Installation

#### REMOVAL

1. Remove the three control knobs from the front air control unit.
2. Remove the cluster lid C. Refer to [IP-10, "Removal and Installation"](#) .
3. Remove the four screws securing the front air control unit to the cluster lid C.
4. Disconnect the two electrical connectors.
5. Remove the front air control unit.

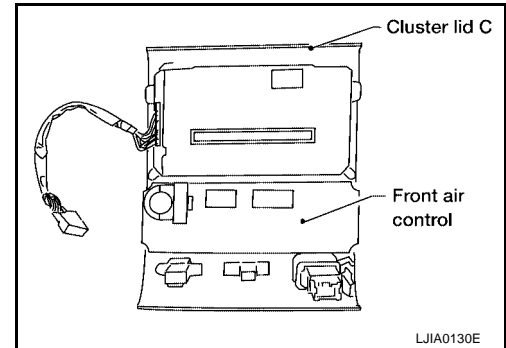

#### INSTALLATION

Installation is in the reverse order of removal.

A

B

C

D

E

F

G

H

I

MTC

K

L

M

# INTAKE SENSOR

## INTAKE SENSOR

PFPP:27723

### Removal and Installation

EJS0032W

#### REMOVAL

1. Remove the instrument panel. Refer to [IP-10, "Removal and Installation"](#).
2. Disconnect the intake sensor electrical connector.

#### NOTE:

The intake sensor is located on the top of the heater and cooling unit assembly next to the A/C evaporator cover.

3. Twist the intake sensor to remove the intake sensor from the heater and cooling unit assembly.

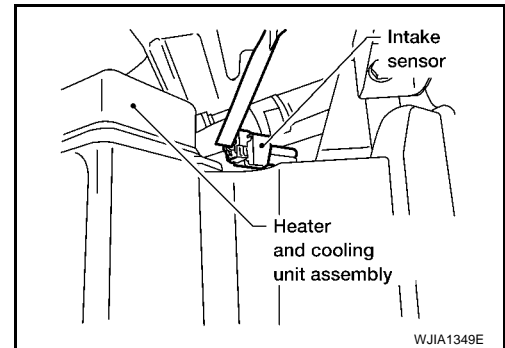

#### INSTALLATION

Installation is in the reverse order of removal.



# BLOWER MOTOR

PFP:27226

EJS0032X

## BLOWER MOTOR

### Removal and Installation

#### Blower Motor - Heater and Cooling Unit Assembly

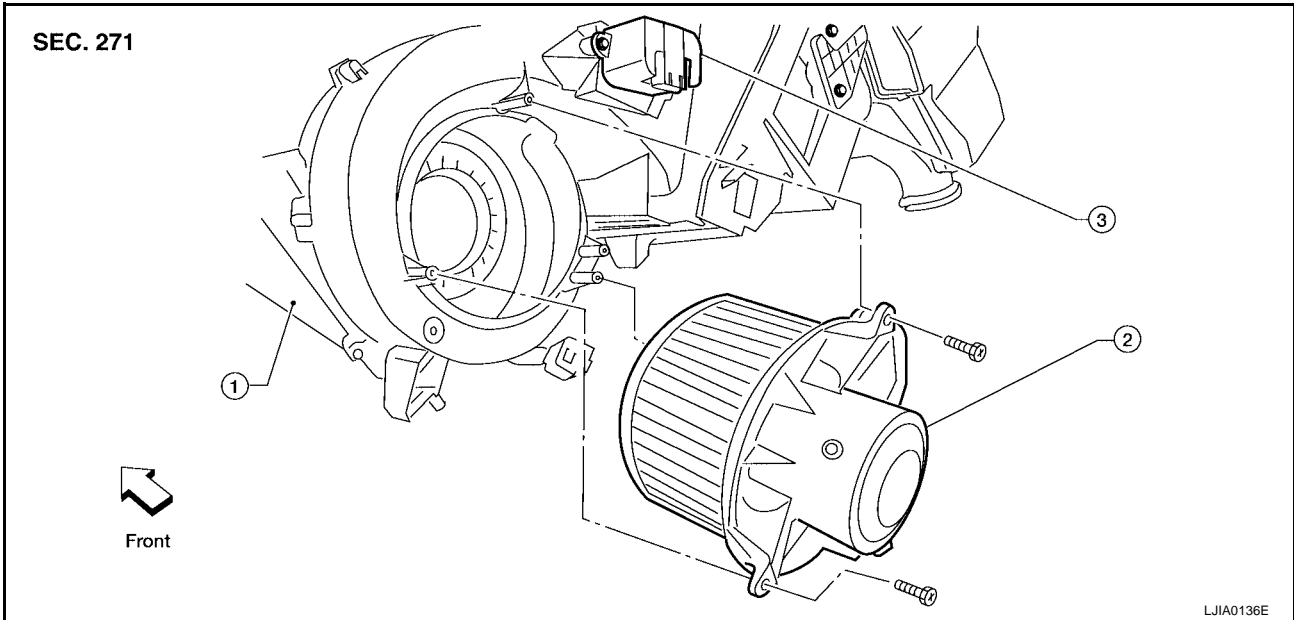

1. Heater and cooling unit assembly
2. Blower motor
3. Variable blower control

#### REMOVAL

1. Remove the glove box assembly. Refer to [IP-10, "Removal and Installation"](#).
2. Disconnect the blower motor electrical connector.
3. Remove the three screws and remove the blower motor.

#### INSTALLATION

Installation is in the reverse order of removal.

A  
B  
C  
D  
E  
F  
G  
H  
I  
K  
L  
M

MTC

# IN-CABIN MICROFILTER

## IN-CABIN MICROFILTER

PF2:27277

### Removal and Installation FUNCTION

EJS0032Y

The air inside the passenger compartment is filtered by the in-cabin microfilters when the heater or A/C controls are set on either the recirculation or fresh mode. The two in-cabin microfilters are located in the front heater and cooling unit assembly.

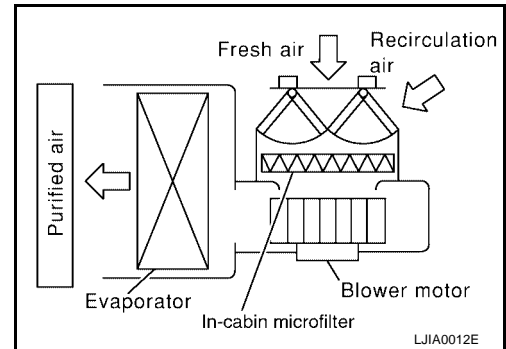

### REPLACEMENT TIMING

Replacement of the two in-cabin microfilters is recommended on a regular interval depending on the driving conditions. Refer to [MA-7, "PERIODIC MAINTENANCE"](#). It may also be necessary to replace the two in-cabin microfilters as part of a component replacement if the in-cabin microfilters are damaged.

### REPLACEMENT PROCEDURE

1. Remove the instrument lower cover RH.

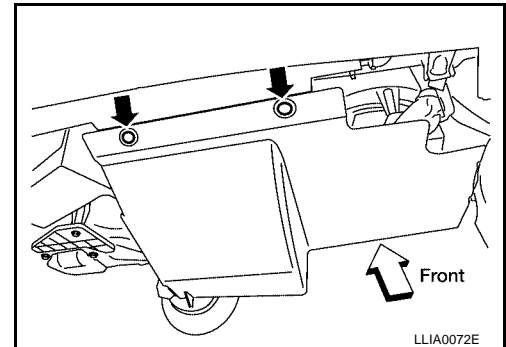

2. Remove the glove box assembly.
  - a. Remove the two lower glove box screws.

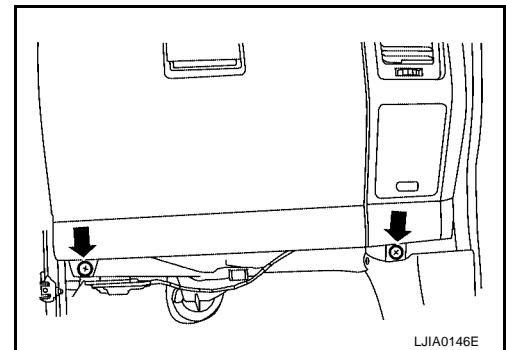

- b. Open the glove box, then remove the four upper glove box screws.

#### NOTE:

It is not necessary to remove the two glove box striker screws.

- c. Remove the glove box assembly from the instrument panel to access the in-cabin microfilter cover.

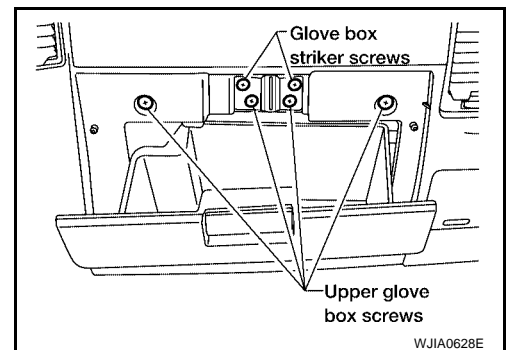

# IN-CABIN MICROFILTER

3. Remove the screw and remove the in-cabin microfilter cover.
4. Remove the in-cabin microfilters from the front heater and cooling unit assembly housing.

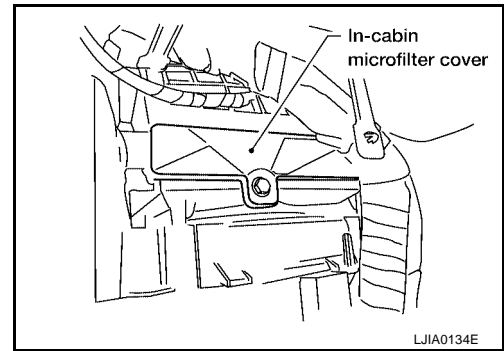

5. Insert the first new in-cabin microfilter into the front heater and cooling unit assembly housing and slide it over to the right. Insert the second new in-cabin microfilter into the front heater and cooling unit assembly housing.

**NOTE:**

The in-cabin microfilters are marked with air flow arrows. The end of the microfilter with the arrow should face the rear of the vehicle. The arrows should point downward.

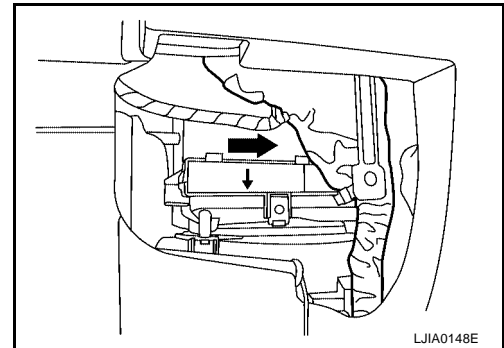

6. Install the in-cabin microfilter cover.

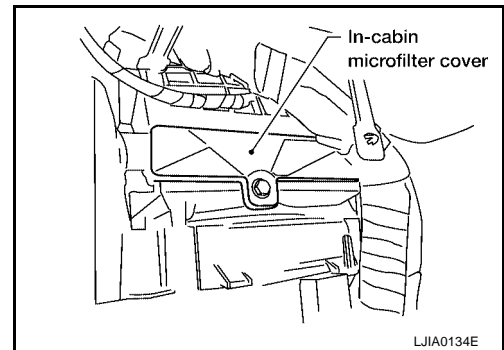

7. Install the glove box assembly in reverse order of removal.

**Lower glove box screws : 3.5 N·m (0.36 kg·m, 31 in·lb)**

**Upper glove box screws : 3.5 N·m (0.36 kg·m, 31 in·lb)**

8. Install the instrument lower cover RH.

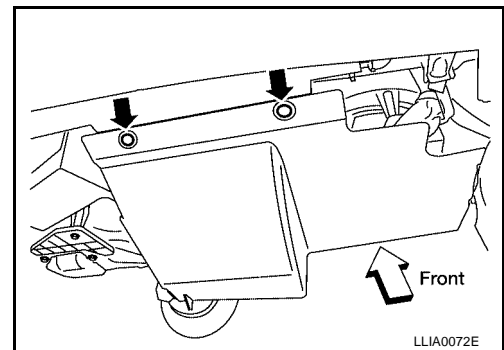

A  
B  
C  
D  
E  
F  
G  
H  
I  
MTC  
K  
L  
M

# HEATER & COOLING UNIT ASSEMBLY

PF2:27110

## HEATER & COOLING UNIT ASSEMBLY

### Removal and Installation

EJS0032Z

SEC. 271 • 276 • 278

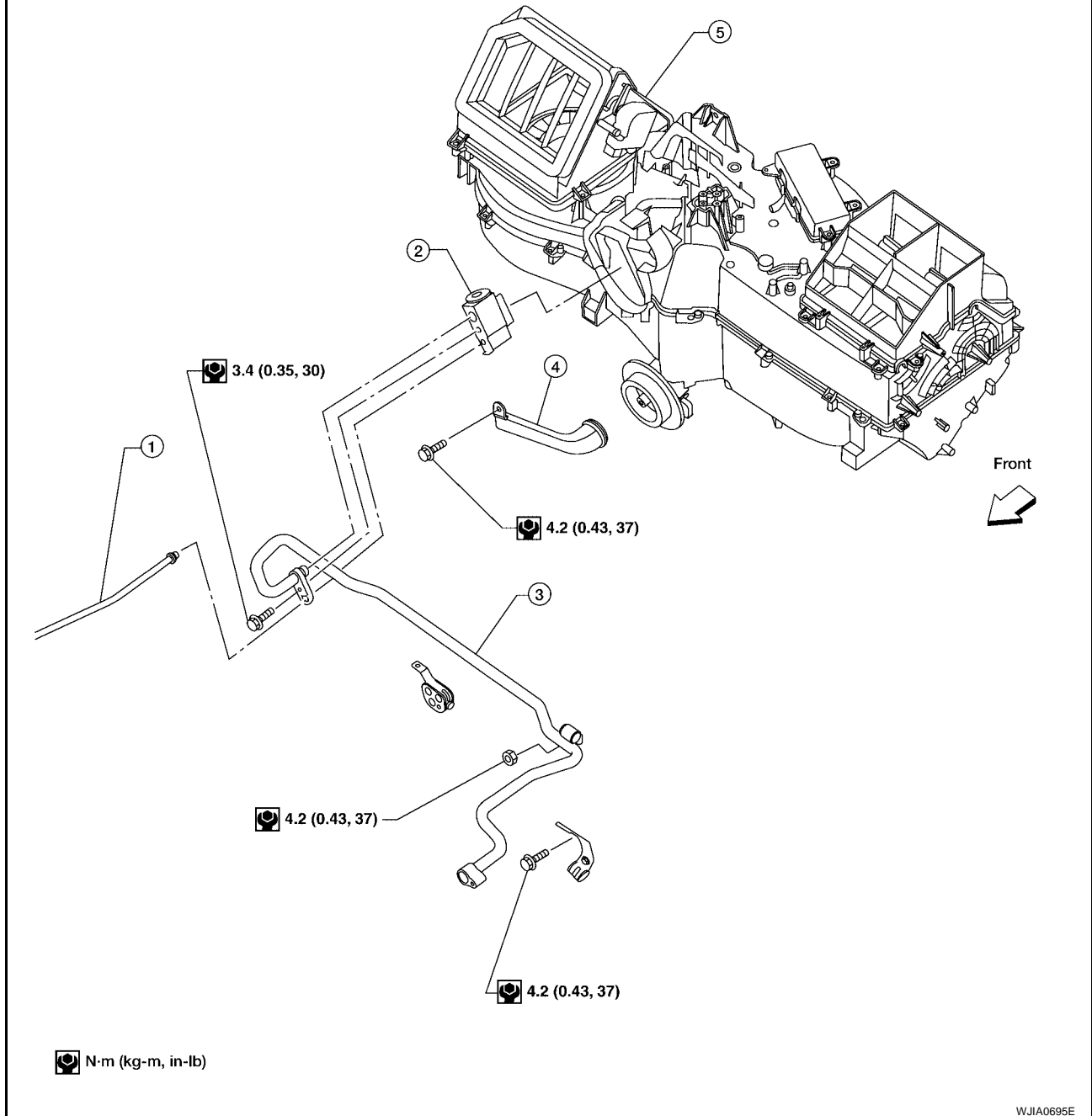

- |                           |                                     |                          |
|---------------------------|-------------------------------------|--------------------------|
| 1. High-pressure A/C pipe | 2. Expansion valve                  | 3. Low-pressure A/C pipe |
| 4. A/C drain hose         | 5. Heater and cooling unit assembly |                          |

### REMOVAL

1. Discharge the refrigerant from the A/C system. Refer to [MTC-112, "Discharging Refrigerant"](#).
2. Drain the coolant from the engine cooling system. Refer to [MA-13, "DRAINING ENGINE COOLANT"](#).
3. Remove the cowl top extension. Refer to [EI-21, "Removal and Installation"](#).
4. Remove the exhaust system. Refer to [EX-3, "Removal and Installation"](#).
5. Disconnect the heater hoses from the heater core.
6. Disconnect the high/low pressure pipes from the expansion valve.
7. Move the two front seats to the rearmost position on the seat track.

# HEATER & COOLING UNIT ASSEMBLY

- 
8. Remove the instrument panel and console panel. Refer to [IP-10, "Removal and Installation"](#) .
  9. Remove the steering column. Refer to [PS-9, "Removal and Installation"](#) .
  10. Disconnect the instrument panel wire harness at the RH and LH in-line connector brackets, and the fuse block (J/B) electrical connectors. Refer to [PG-38, "Harness Layout"](#) .
  11. Disconnect the steering member from each side of the vehicle body.
  12. Remove the heater and cooling unit assembly with it attached to the steering member, from the vehicle.

**CAUTION:**

**Use care not to damage the seats and interior trim panels when removing the heater and cooling unit assembly with it attached to the steering member.**

13. Remove the heater and cooling unit assembly from the steering member.

## INSTALLATION

Installation is in the reverse order of removal.

**CAUTION:**

- **Replace the O-ring of the low-pressure pipe and high-pressure pipe with a new one, and apply compressor oil to it when installing it.**
- **After charging the refrigerant, check for leaks.**

**NOTE:**

- Fill the engine cooling system with the specified coolant mixture. Refer to [MA-11, "Fluids and Lubricants"](#) .
- Recharge the A/C system. Refer to [MTC-112, "Evacuating System and Charging Refrigerant"](#) .

A

B

C

D

E

F

G

H

I

MTC

K

L

M

# HEATER CORE

## HEATER CORE

PF27140

### Removal and Installation

EJS00330

#### Heater and Cooling Unit Assembly

SEC. 271

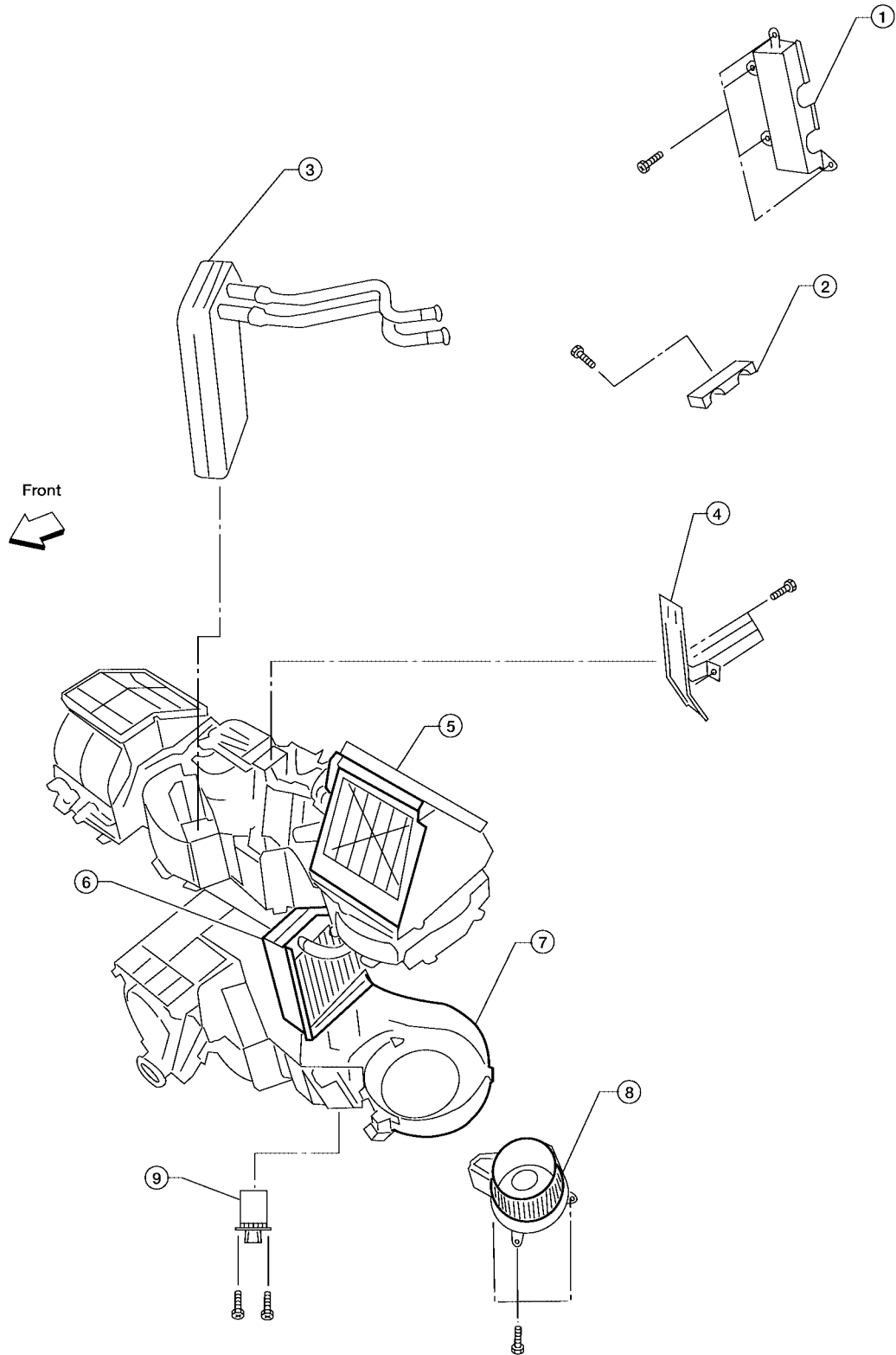

- |                                       |                                       |                            |
|---------------------------------------|---------------------------------------|----------------------------|
| 1. Heater core cover                  | 2. Heater core pipe bracket           | 3. Heater core             |
| 4. Upper bracket                      | 5. Upper heater and cooling unit case | 6. A/C evaporator          |
| 7. Lower heater and cooling unit case | 8. Blower motor                       | 9. Variable blower control |

LJJA0138E

# HEATER CORE

## REMOVAL

1. Remove the heater and cooling unit assembly. Refer to [MTC-100, "Removal and Installation"](#).
2. Remove the four screws and remove the upper bracket.
3. Remove the four screws and remove the heater core cover.
4. Remove the heater core pipe bracket.
5. Remove the heater core.

### NOTE:

If the in-cabin microfilters are contaminated from coolant leaking from the heater core, replace the in-cabin microfilters with new ones before installing the new heater core.

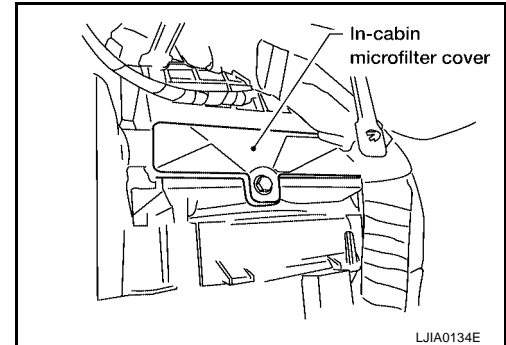

## INSTALLATION

Installation is in the reverse order of removal.

A

B

C

D

E

F

G

H

I

MTC

K

L

M

# DEFROSTER DOOR MOTOR

## DEFROSTER DOOR MOTOR

PF2:27733

### Removal and Installation

EJS00331

#### Defroster Door Motor - Heater and Cooling Unit Assembly

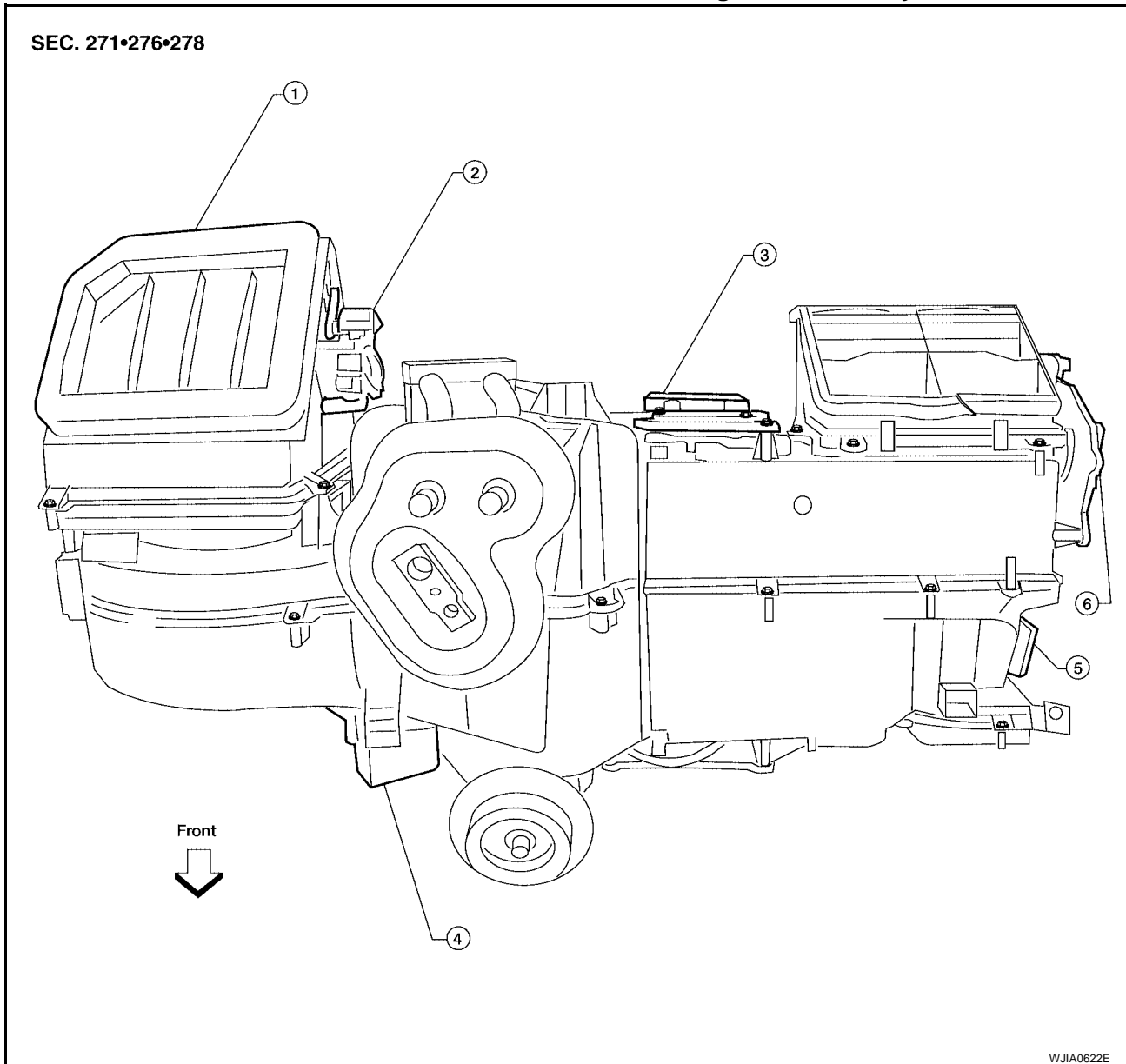

- |                                     |                      |                         |
|-------------------------------------|----------------------|-------------------------|
| 1. Heater and cooling unit assembly | 2. Intake door motor | 3. Air mix door motor   |
| 4. Variable blower control          | 5. Mode door motor   | 6. Defroster door motor |

### REMOVAL

1. Remove the heater and cooling unit assembly. Refer to [MTC-100, "Removal and Installation"](#).
2. Remove the steering member from the heater and cooling unit assembly.
3. Disconnect the defroster door motor electrical connector.
4. Remove the three screws and remove the defroster door motor.

### INSTALLATION

Installation is in the reverse order of removal.



# INTAKE DOOR MOTOR

PF2:27730

EJS00332

## INTAKE DOOR MOTOR Removal and Installation

### Intake Door Motor - Heater and Cooling Unit Assembly

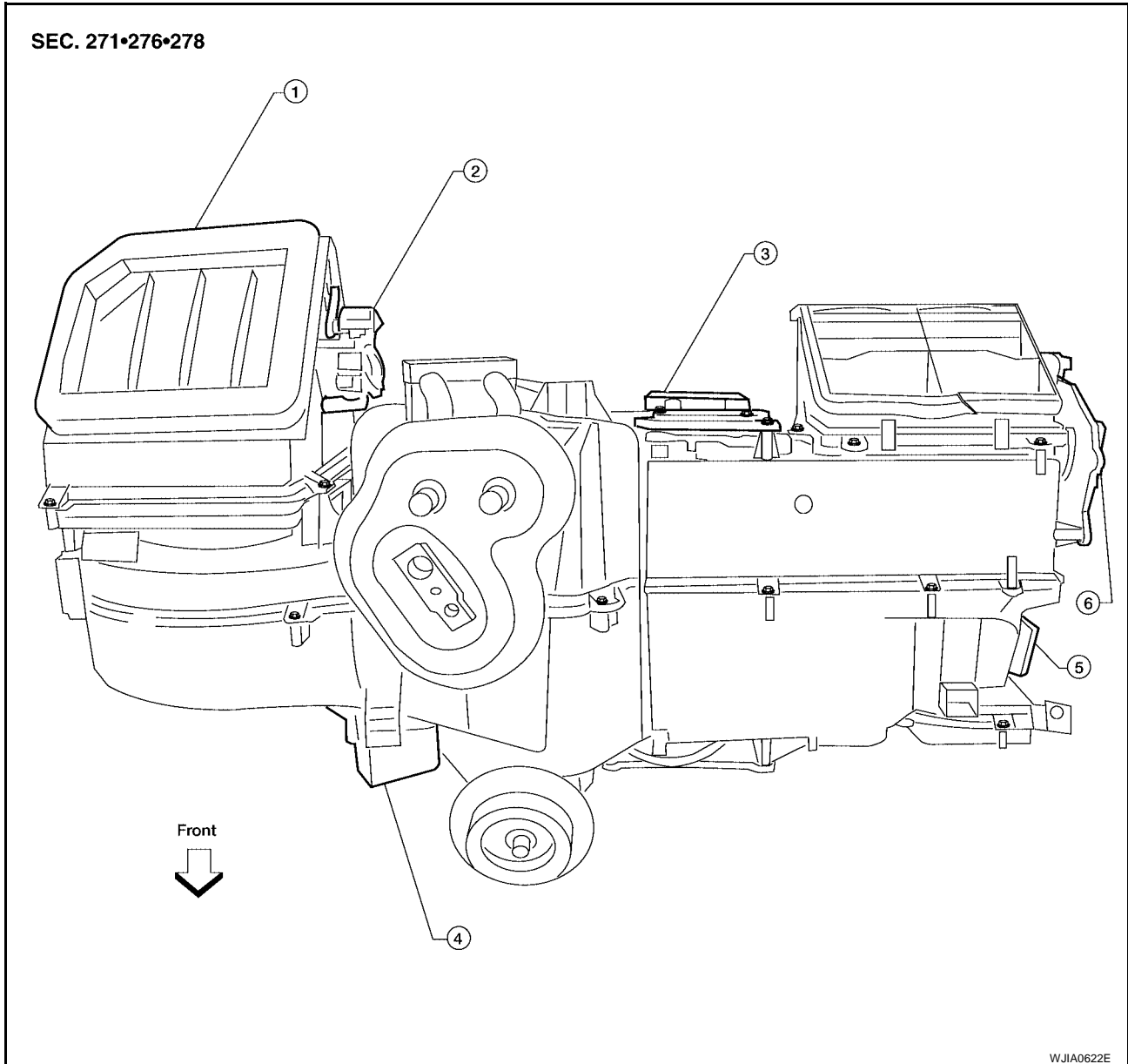

- |                                     |                      |                         |
|-------------------------------------|----------------------|-------------------------|
| 1. Heater and cooling unit assembly | 2. Intake door motor | 3. Air mix door motor   |
| 4. Variable blower control          | 5. Mode door motor   | 6. Defroster door motor |

#### REMOVAL

1. Remove the heater and cooling unit assembly. Refer to [MTC-100, "Removal and Installation"](#).
2. Remove the steering member from the heater and cooling unit assembly.
3. Disconnect the intake door motor electrical connector.
4. Remove the three screws and remove the intake door motor.

#### INSTALLATION

Installation is in the reverse order of removal.

# MODE DOOR MOTOR

## MODE DOOR MOTOR

PF2:27731

## Removal and Installation

EJS00333

### Mode Door Motor - Heater and Cooling Unit Assembly

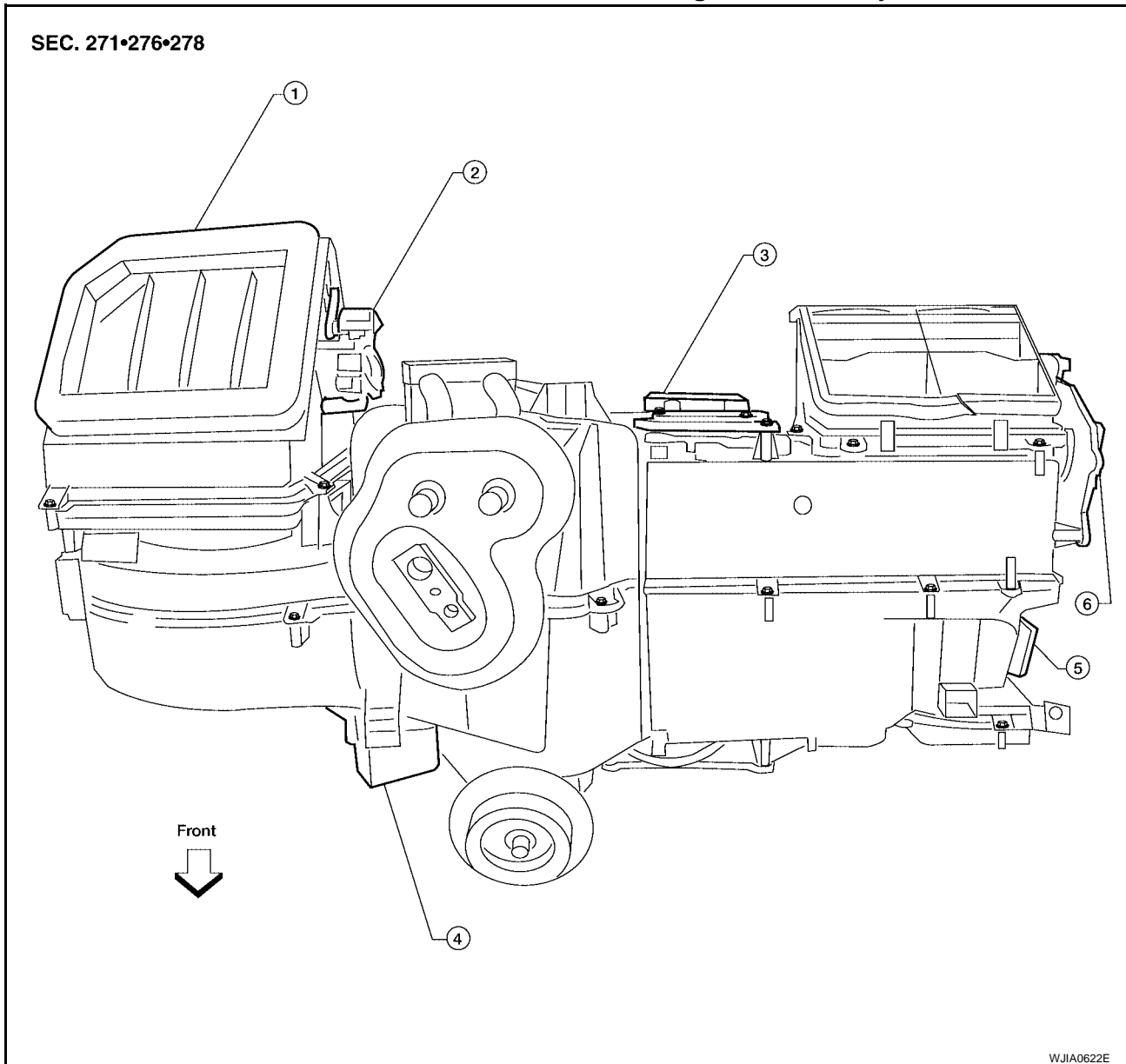

- |                                     |                      |                         |
|-------------------------------------|----------------------|-------------------------|
| 1. Heater and cooling unit assembly | 2. Intake door motor | 3. Air mix door motor   |
| 4. Variable blower control          | 5. Mode door motor   | 6. Defroster door motor |

### REMOVAL

1. Remove the heater and cooling unit assembly. Refer to [MTC-100, "Removal and Installation"](#).
2. Remove the steering member from the heater and cooling unit assembly.
3. Disconnect the mode door motor electrical connector.
4. Remove the two screws and remove the mode door motor.

### INSTALLATION

Installation is in the reverse order of removal.

# AIR MIX DOOR MOTOR

PF2:27732

EJS00334

## AIR MIX DOOR MOTOR Removal and Installation

### Air Mix Door Motor - Heater and Cooling Unit Assembly

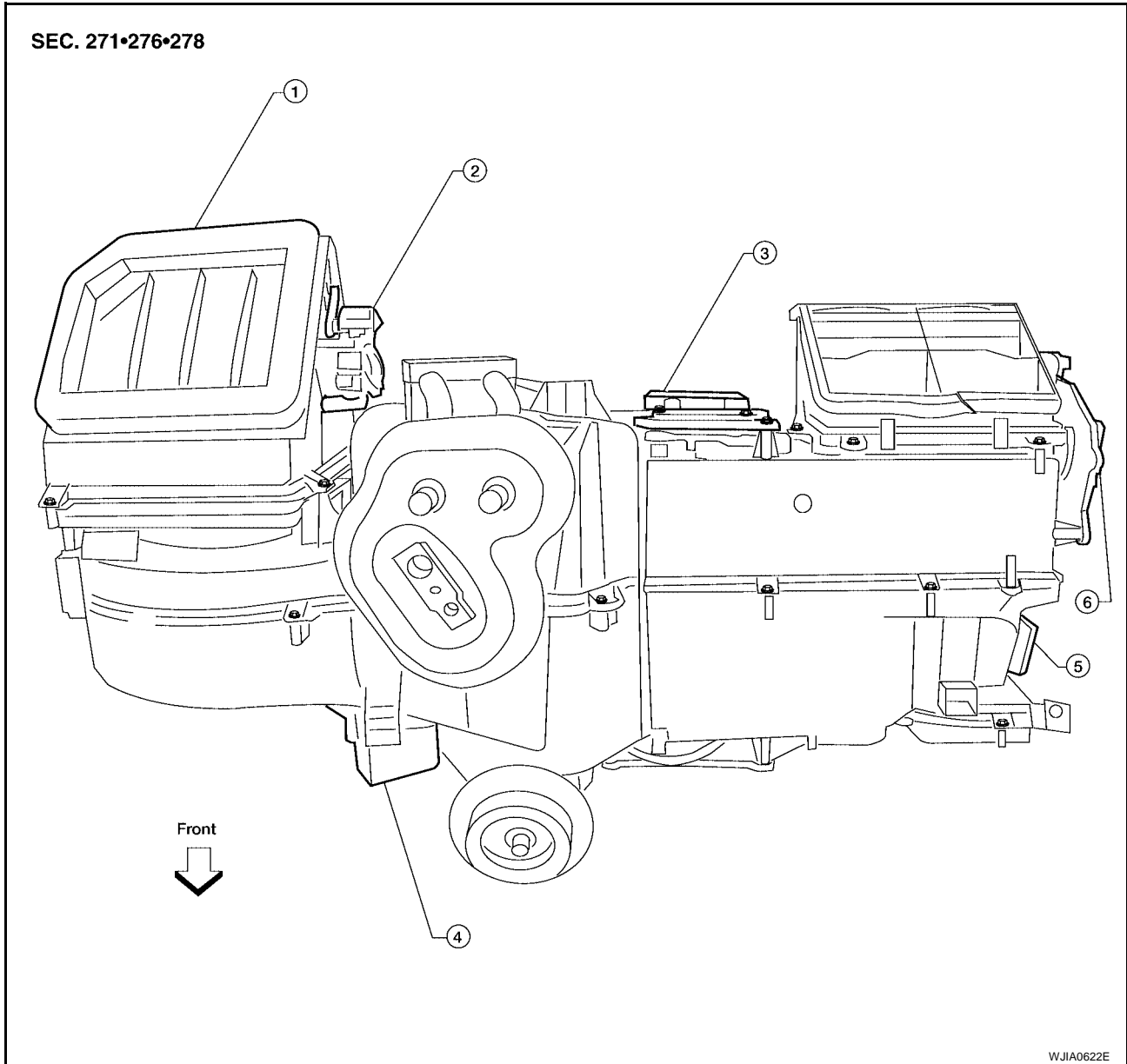

- |                                     |                      |                         |
|-------------------------------------|----------------------|-------------------------|
| 1. Heater and cooling unit assembly | 2. Intake door motor | 3. Air mix door motor   |
| 4. Variable blower control          | 5. Mode door motor   | 6. Defroster door motor |

#### REMOVAL

1. Remove the heater and cooling unit assembly. Refer to [MTC-100, "Removal and Installation"](#).
2. Remove the steering member from the heater and cooling unit assembly.
3. Disconnect the air mix door motor electrical connector.
4. Remove the three screws and remove the air mix door motor.

#### INSTALLATION

Installation is in the reverse order of removal.

A  
B  
C  
D  
E  
F  
G  
H  
I  
K  
L  
M

MTC

# VARIABLE BLOWER CONTROL

## VARIABLE BLOWER CONTROL

PF20:27200

### Removal and Installation

EJS00335

#### Variable Blower Control - Heater and Cooling Unit Assembly

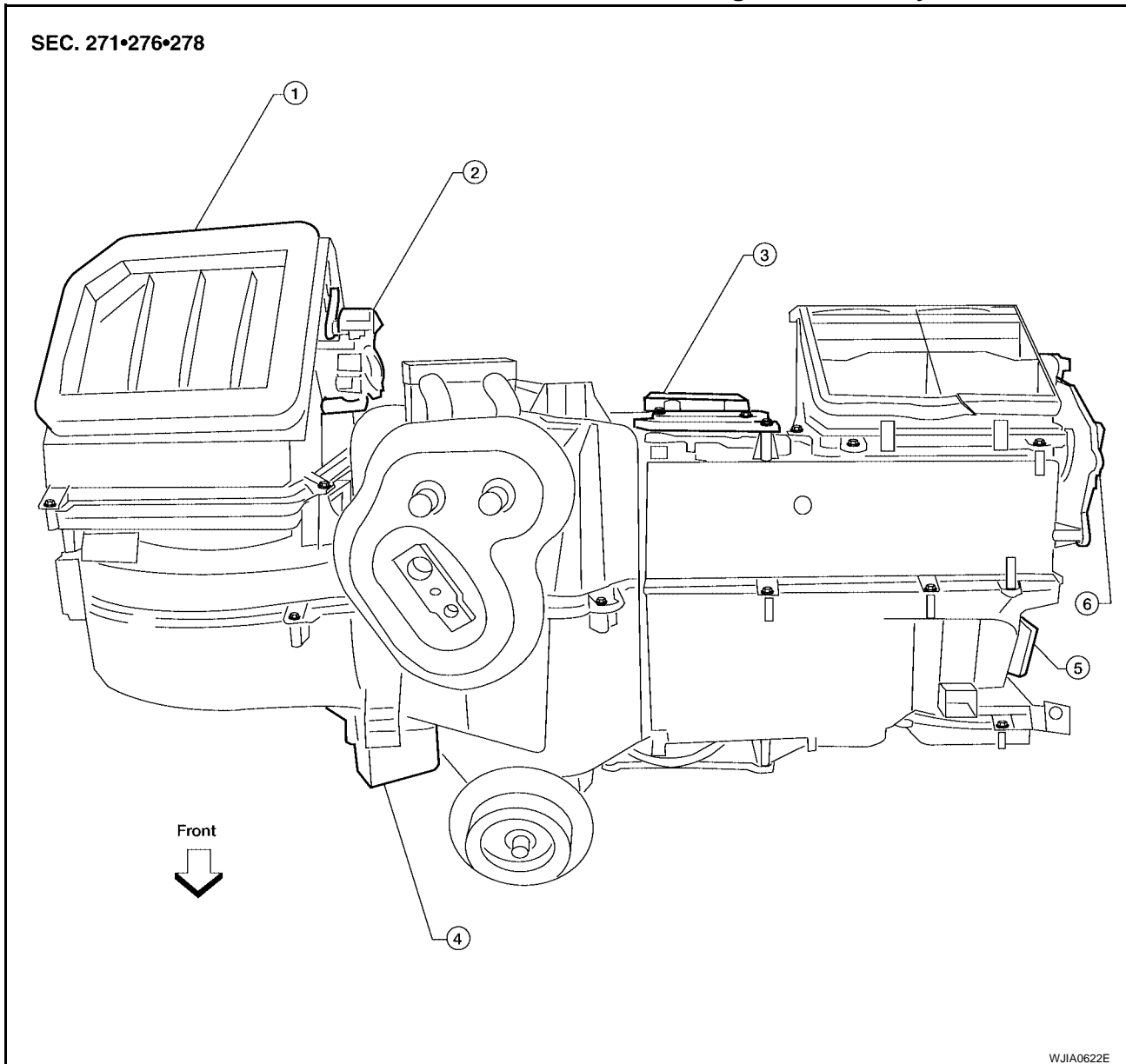

- |                                     |                      |                         |
|-------------------------------------|----------------------|-------------------------|
| 1. Heater and cooling unit assembly | 2. Intake door motor | 3. Air mix door motor   |
| 4. Variable blower control          | 5. Mode door motor   | 6. Defroster door motor |

### REMOVAL

1. Remove the heater and cooling unit assembly. Refer to [MTC-100, "Removal and Installation"](#).
2. Remove the steering member from the heater and cooling unit assembly.
3. Disconnect the blower motor resistor electrical connector.
4. Remove the two screws and remove the blower motor resistor.

### INSTALLATION

Installation is in the reverse order of removal.

# DUCTS AND GRILLES

## DUCTS AND GRILLES Removal and Installation

PF27860

EJS00336

### Ducts - Heater and Cooling Unit Assembly

SEC. 270 • 271

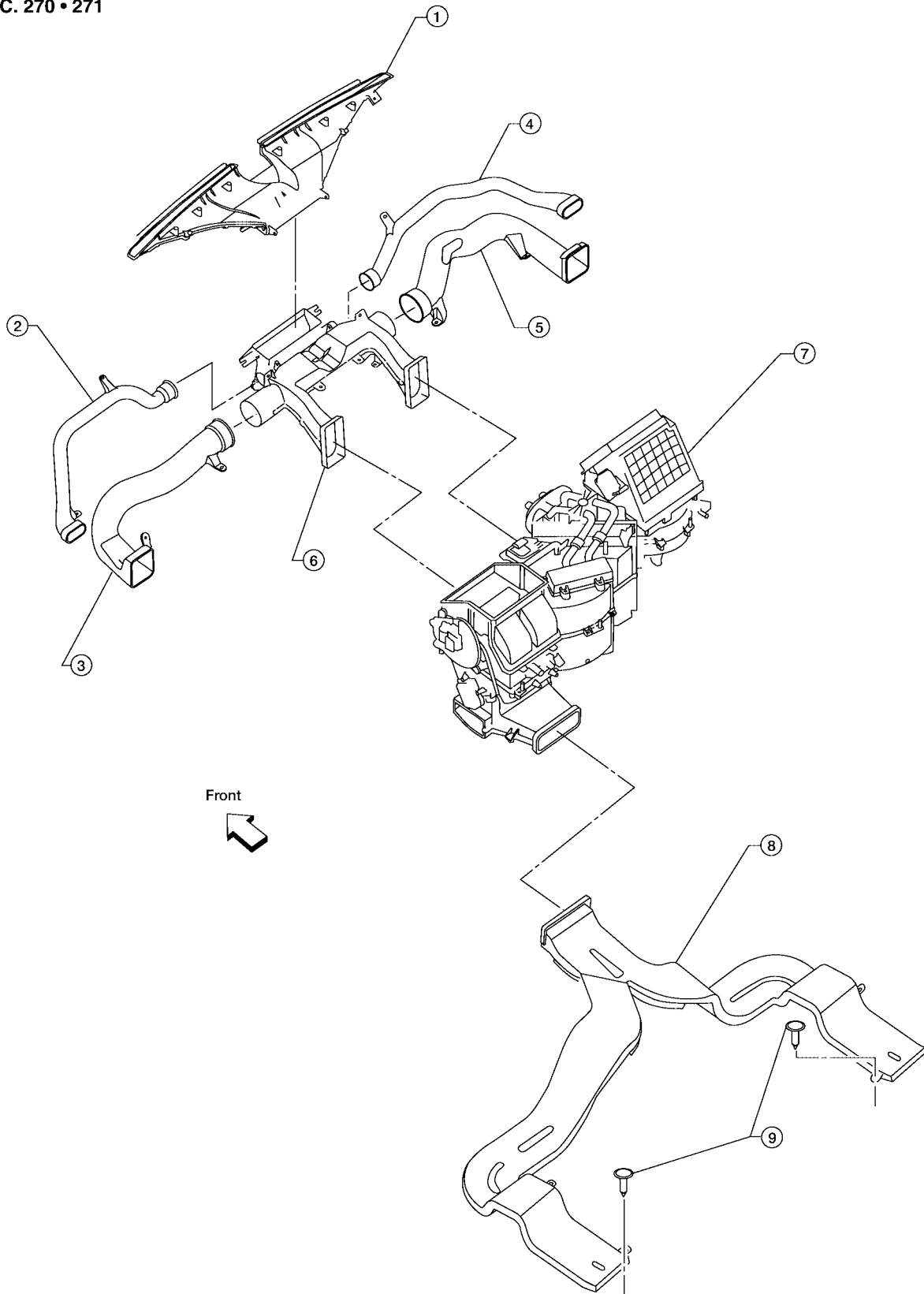

A  
B  
C  
D  
E  
F  
G  
H  
I  
K  
L  
M

MTC

# DUCTS AND GRILLES

- |                                     |                          |                           |
|-------------------------------------|--------------------------|---------------------------|
| 1. Defroster nozzle                 | 2. LH side demister duct | 3. LH ventilator duct     |
| 4. RH side demister duct            | 5. RH ventilator duct    | 6. Center ventilator duct |
| 7. Heater and cooling unit assembly | 8. Floor duct            | 9. Clips                  |

## Grilles

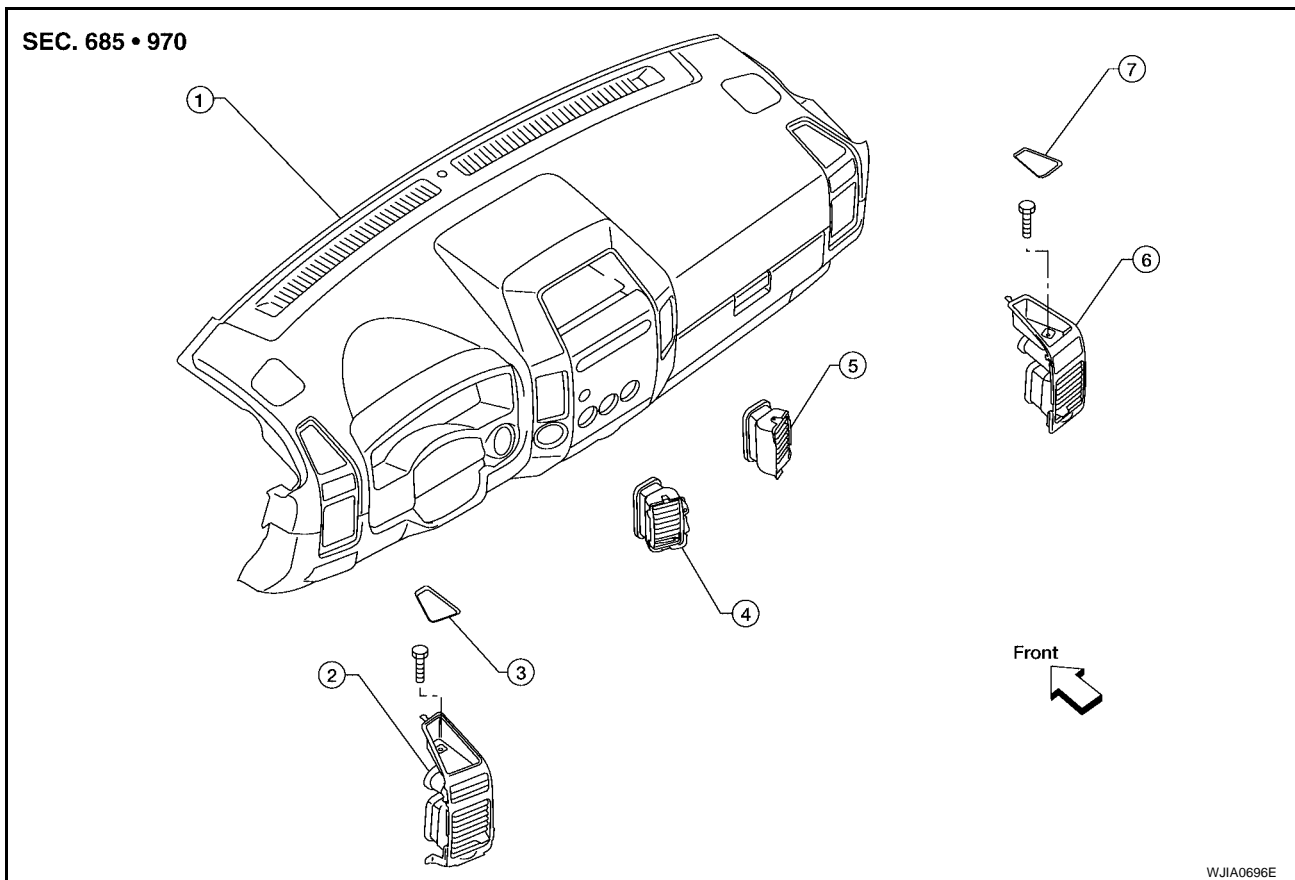

- |                                   |                                |                                   |
|-----------------------------------|--------------------------------|-----------------------------------|
| 1. Instrument panel               | 2. Side ventilator assembly LH | 3. Storage tray bottom cover (LH) |
| 4. Cluster lid D ventilator LH    | 5. Cluster lid D ventilator RH | 6. Side ventilator assembly RH    |
| 7. Storage tray bottom cover (RH) |                                |                                   |

## DEFROSTER NOZZLE

### Removal

1. Remove the instrument panel trim. Refer to [IP-10, "Removal and Installation"](#).
2. Remove the heater and cooling unit assembly. Refer to [MTC-100, "Removal and Installation"](#).
3. Remove the defroster nozzle.

### Installation

Installation is in the reverse order of removal.

## RH AND LH SIDE DEMISTER DUCT

### Removal

1. Remove the instrument panel trim. Refer to [IP-10, "Removal and Installation"](#).
2. Remove the heater and cooling unit assembly. Refer to [MTC-100, "Removal and Installation"](#).
3. Remove the RH or LH side demister duct.

### Installation

Installation is in the reverse order of removal.

## RH AND LH VENTILATOR DUCT

### Removal

1. Remove the instrument panel trim. Refer to [IP-10, "Removal and Installation"](#).
2. Remove the heater and cooling unit assembly. Refer to [MTC-100, "Removal and Installation"](#).

# DUCTS AND GRILLES

3. Remove the RH or LH ventilator duct.

## Installation

Installation is in the reverse order of removal.

## CENTER VENTILATOR DUCT

### Removal

1. Remove the instrument panel trim. Refer to [IP-10, "Removal and Installation"](#) .
2. Remove the heater and cooling unit assembly. Refer to [MTC-100, "Removal and Installation"](#) .
3. Remove the defroster nozzle.
4. Remove the RH and LH side demister ducts.
5. Remove the RH and LH ventilator ducts.
6. Remove the center ventilator duct.

### Installation

Installation is in the reverse order of removal.

## FLOOR DUCT

### Removal

1. Remove the floor carpet. Refer to [EI-41, "FLOOR TRIM"](#) .
2. Remove the two clips and remove the floor duct.

### Installation

Installation is in the reverse order of removal.

## GRILLES

### Removal

1. Remove the interior trim panel as necessary. Refer to [EI-36, "BODY SIDE TRIM"](#) or [EI-43, "HEADLINING"](#) .
2. Remove the ventilator grille from the interior trim panel.

### Installation

Installation is in the reverse order of removal.

A

B

C

D

E

F

G

H

I

MTC

K

L

M

# REFRIGERANT LINES

PPF:92600

EJS00337

## REFRIGERANT LINES

### HFC-134a (R-134a) Service Procedure SETTING OF SERVICE TOOLS AND EQUIPMENT Discharging Refrigerant

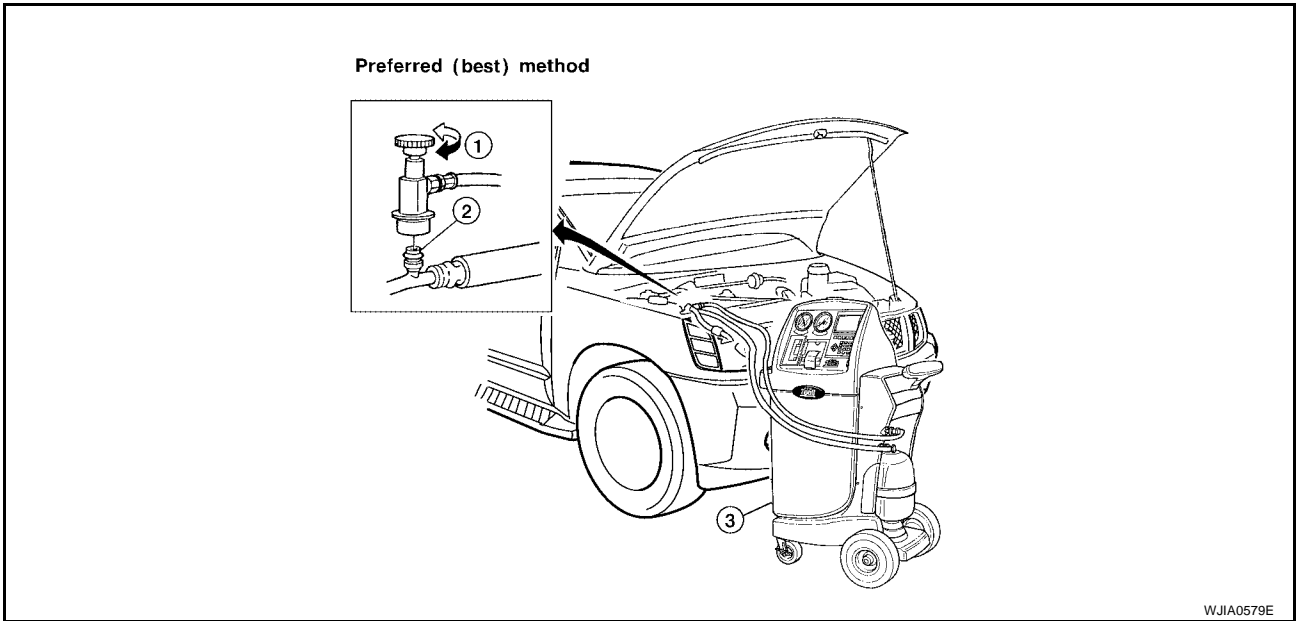

1. Shut-off valve
2. A/C service valve
3. Recovery/Recycling equipment ACR 2000 (J-43600) with refrigerant identifier

#### **WARNING:**

Avoid breathing A/C refrigerant and lubricant vapor or mist. Exposure may irritate eyes, nose and throat. Remove HFC-134a (R-134a) refrigerant from the A/C system using certified service equipment meeting requirements of SAE J2210 HFC-134a (R-134a) recycling equipment or SAE J2201 HFC-134a (R-134a) recovery equipment. If an accidental system discharge occurs, ventilate the work area before resuming service. Additional health and safety information may be obtained from the refrigerant and lubricant manufacturers.

### Evacuating System and Charging Refrigerant

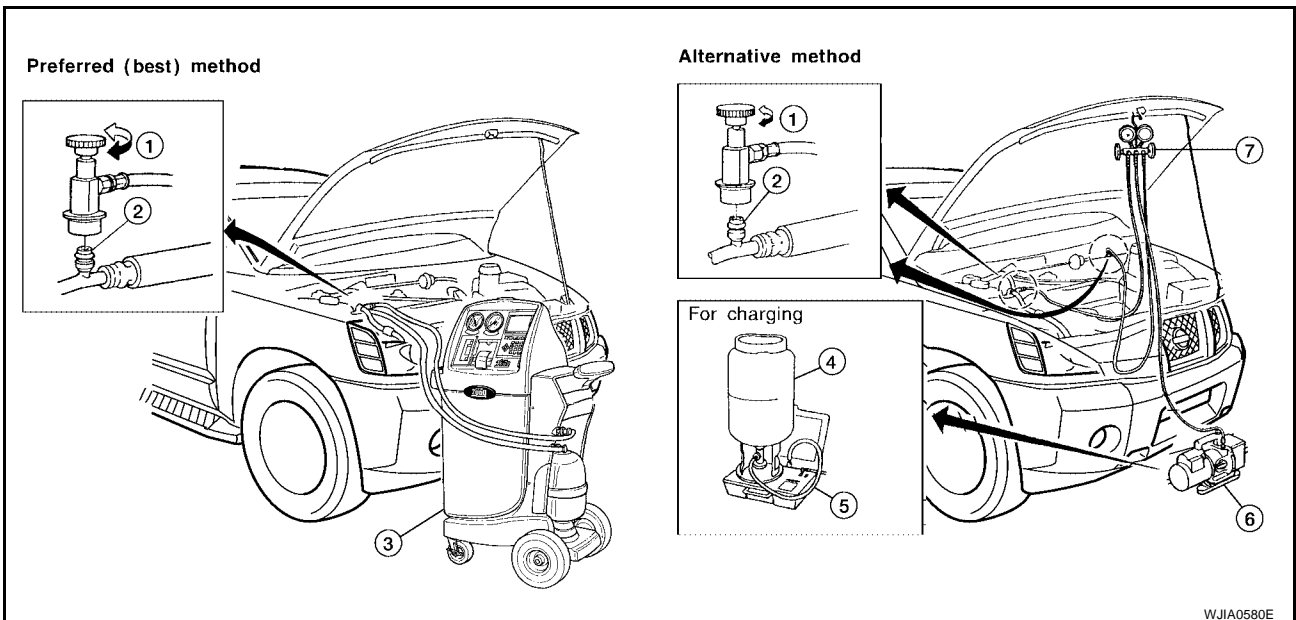

1. Shut-off valve
2. A/C service valve
3. Recovery/Recycling equipment ACR 2000 (J-43600) with refrigerant identifier



# REFRIGERANT LINES

4. Refrigerant container (HFC-134a) 5. Weight scale (J-39650) 6. Evacuating vacuum pump (J-39699)  
7. Manifold gauge set (J-39183)

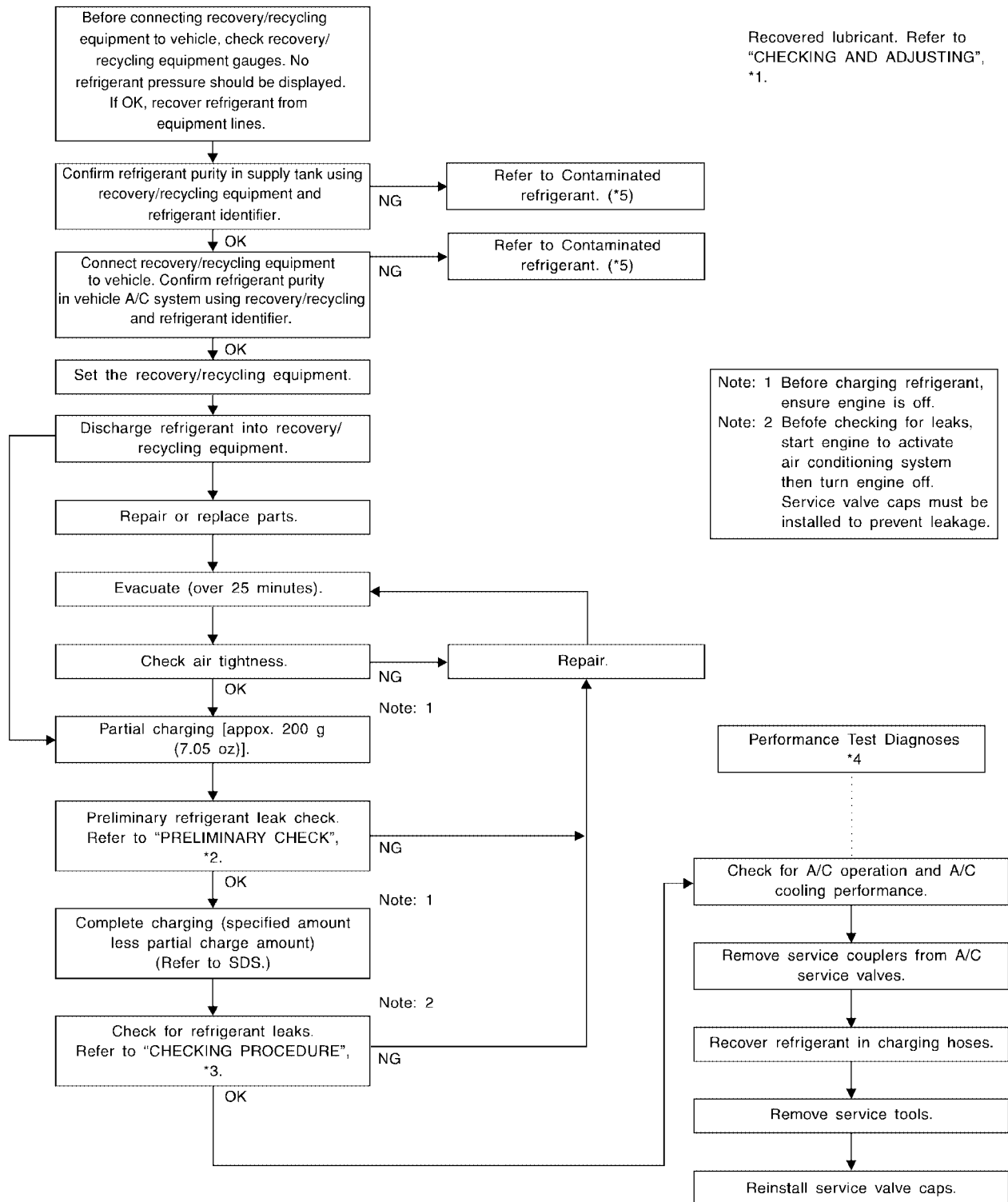

\*1 [MTC-20. "CHECKING AND ADJUSTING"](#)

\*2 [MTC-123. "Checking for Refrigerant Leaks"](#)

\*3 [MTC-123. "Checking for Refrigerant Leaks"](#)

\*4 [MTC-81. "PERFORMANCE TEST DIAGNOSES"](#)

\*5 [MTC-4. "Contaminated Refrigerant"](#)

WJIA0530E

# REFRIGERANT LINES

## Components

EJS00338

### A/C Compressor and Condenser

SEC. 214 • 271 • 274 • 276

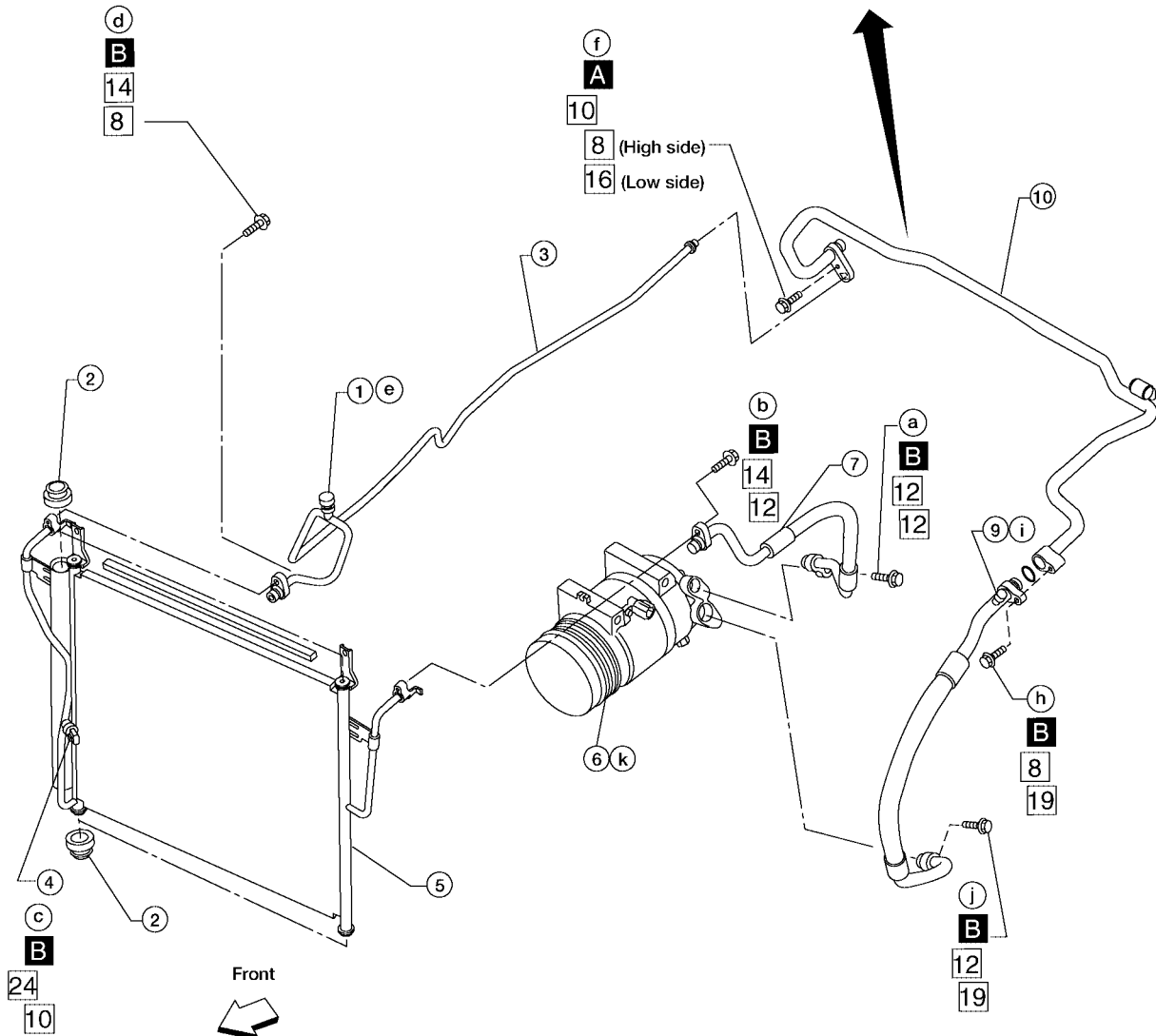
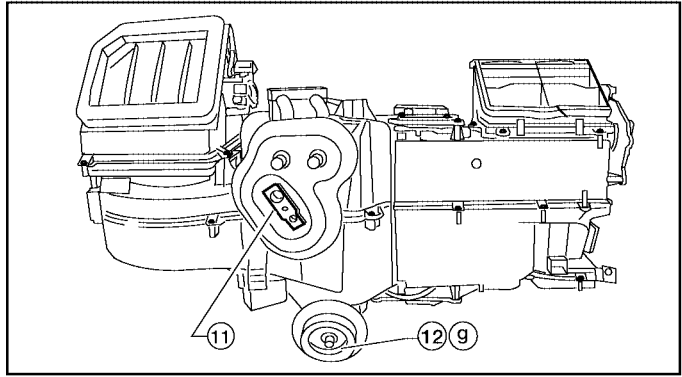

- : Refrigerant leak checking order (a-k)
- : Tightening torque
- □ : Wrench size
- : O-ring size
- ⊗ : N-m (kg-m, in-lb)
- A** ⊗ : 3.4 (0.35, 30)
- B** ⊗ : 9.3 (0.95, 82)

WJIA1020E

# REFRIGERANT LINES

- |                                |                               |                               |
|--------------------------------|-------------------------------|-------------------------------|
| 1. High-pressure service valve | 2. Grommet                    | 3. High-pressure pipe         |
| 4. Refrigerant pressure sensor | 5. Condenser                  | 6. Compressor shaft seal      |
| 7. High-pressure flexible hose | 8. Low-pressure flexible hose | 9. Low-pressure service valve |
| 10. Low-pressure pipe          | 11. Expansion valve           | 12. Drain hose                |

## NOTE:

Refer to [MTC-6, "Precautions for Refrigerant Connection"](#) .

## Removal and Installation for Compressor

EJS00339

### A/C Compressor Mounting

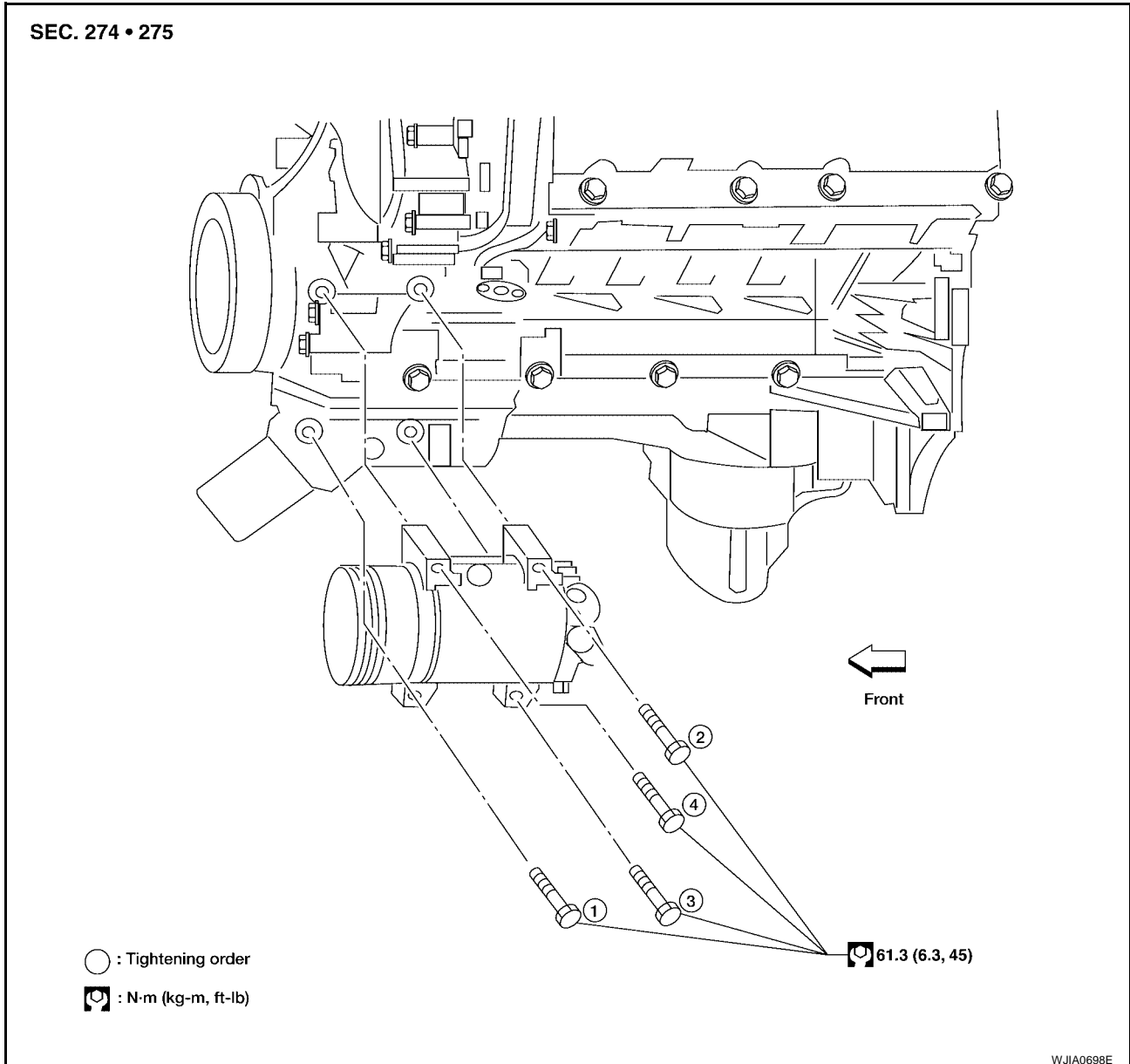

## REMOVAL

1. Discharge the refrigerant. Refer to [MTC-112, "HFC-134a \(R-134a\) Service Procedure"](#) .
2. Remove the front right wheel and tire assembly. Refer to [WT-6, "Rotation"](#) .
3. Remove the engine under cover and the splash shield using power tool.
4. Remove the engine air cleaner and air ducts. Refer to [EM-14, "AIR CLEANER AND AIR DUCT"](#) .
5. Remove the drive belt. Refer to [EM-12, "DRIVE BELTS"](#) .
6. Disconnect the compressor electrical connector.
7. Disconnect the high-pressure flexible hose and low-pressure flexible hose from the compressor.

# REFRIGERANT LINES

## CAUTION:

Cap or wrap the joint of the pipe with suitable material such as vinyl tape to avoid the entry of air.

8. Remove the compressor bolts and nut using power tools.

## INSTALLATION

Installation is in the reverse order of removal.

## CAUTION:

- Replace the O-ring of the low-pressure flexible hose and high-pressure flexible hose with a new one, apply compressor oil to the O-rings before installation.
- After recharging the A/C system with refrigerant, check for leaks.

## Removal and Installation for Compressor Clutch

EJS0033A

### Magnet Clutch Assembly

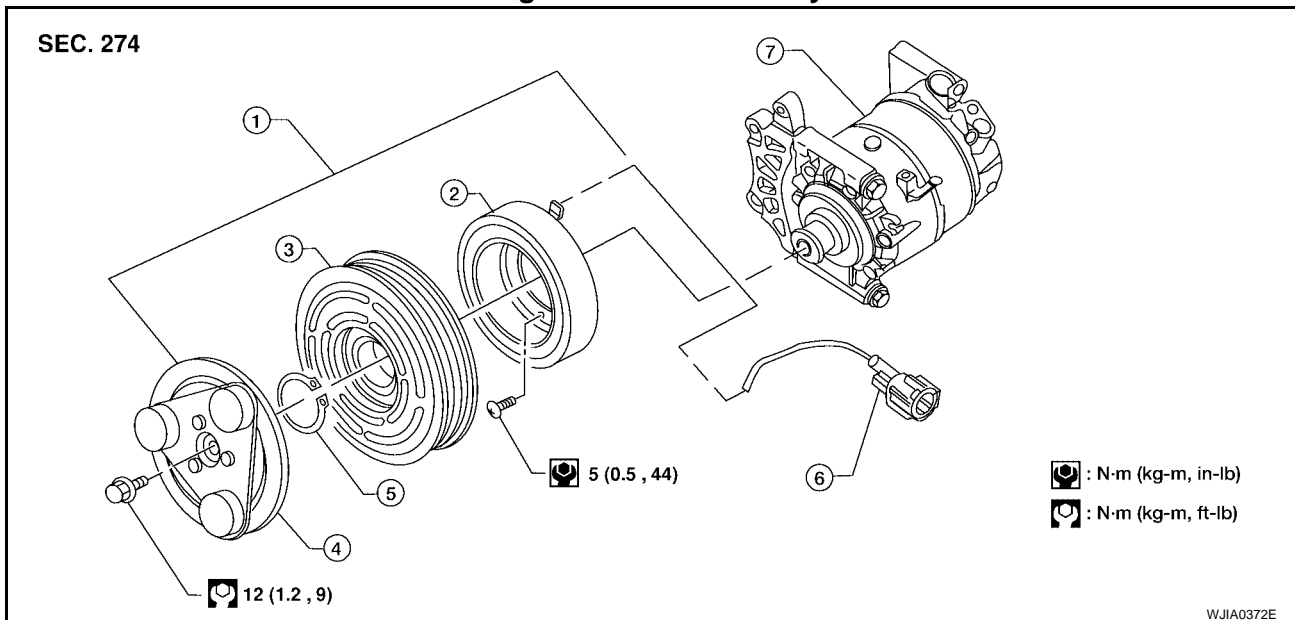

- |                           |                |                                 |
|---------------------------|----------------|---------------------------------|
| 1. Magnet clutch assembly | 2. Magnet coil | 3. Pulley                       |
| 4. Clutch disc            | 5. Snap ring   | 6. Thermal protector (built in) |
| 7. Compressor             |                |                                 |

## REMOVAL

1. Remove the compressor. Refer to [MTC-115, "Removal and Installation for Compressor"](#).
2. Remove the center bolt while holding the clutch disc stationary using Tool as shown.

**Tool number : J-44614**

3. Remove the clutch disc.

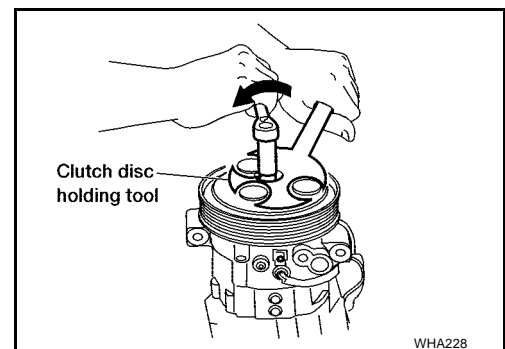

# REFRIGERANT LINES

4. Remove the snap ring using external snap ring pliers or suitable tool.

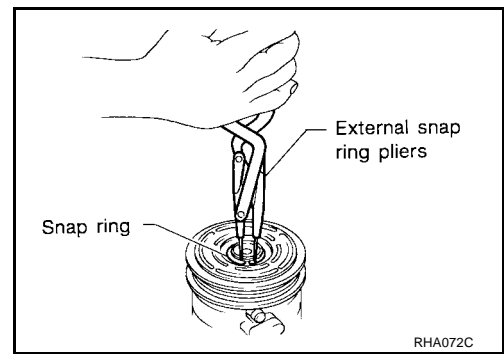

5. Remove the pulley using Tool with a small adapter. Position the small adapter on the end of the drive shaft and the center of the puller on the small adapter.

**Tool number : KV99233130 (J-29884)**

**CAUTION:**

**To prevent deformation of the pulley groove, the puller claws should be hooked under the pulley groove and not into the pulley groove.**

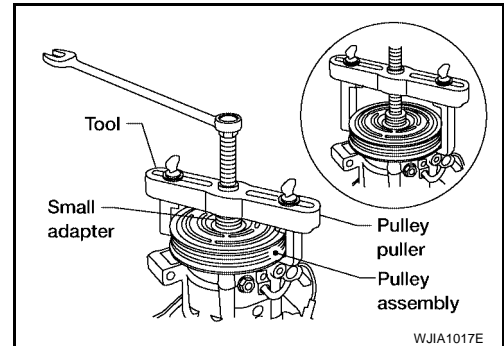

6. Remove the magnet coil harness clip using a screwdriver, remove the three magnet coil fixing screws and remove the magnet coil.

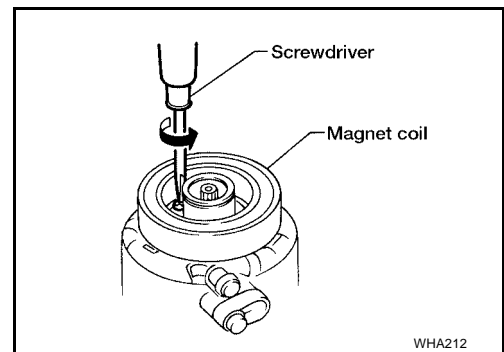

## INSPECTION

### Clutch Disc

If the contact surface shows signs of damage due to excessive heat, replace clutch disc and pulley.

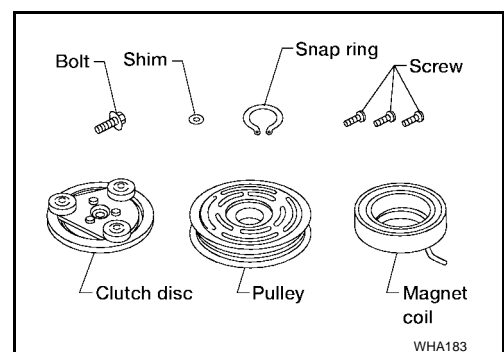

### Pulley

Check the appearance of the pulley assembly. If contact surface of pulley shows signs of excessive grooving, replace clutch disc and pulley. The contact surfaces of the pulley assembly should be cleaned with a suitable solvent before reinstallation.

### Coil

Check magnet coil for loose connections or any cracked insulation.

A  
B  
C  
D  
E  
F  
G  
H  
I  
MTC  
K  
L  
M

# REFRIGERANT LINES

## INSTALLATION

1. Install the magnet coil.

**CAUTION:**

Be sure to align the magnet coil pin with the hole in the compressor front head.

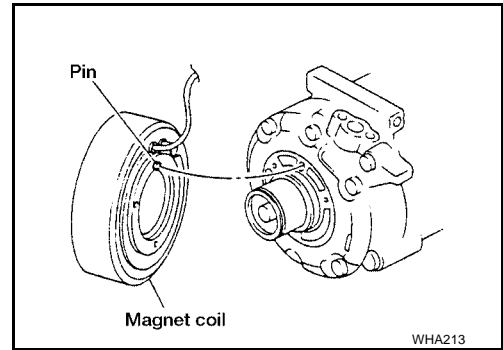

2. Install the magnet coil harness clip using a screwdriver.
3. Install the pulley assembly using Tool and a wrench, then install the snap ring using snap ring pliers.

**Tool number** : — (J-38873-A)

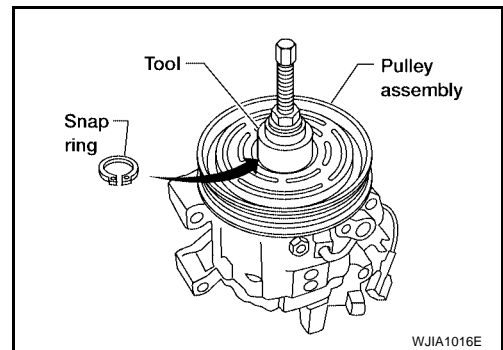

4. Install the clutch disc on the compressor shaft, together with the original shim(s). Press the clutch disc down by hand.

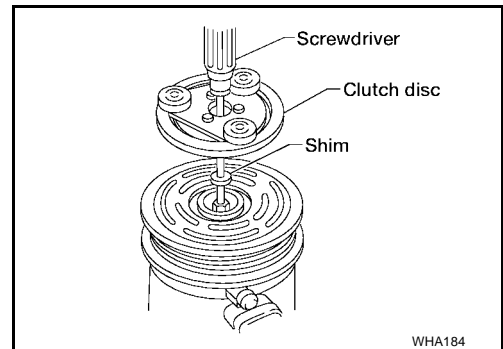

5. Install the clutch pulley bolt using Tool, to prevent the clutch disc from turning and tighten the bolt to specification.

**Tool number** : J-44614

**CAUTION:**

After tightening the clutch pulley bolt, check that the clutch pulley rotates smoothly.

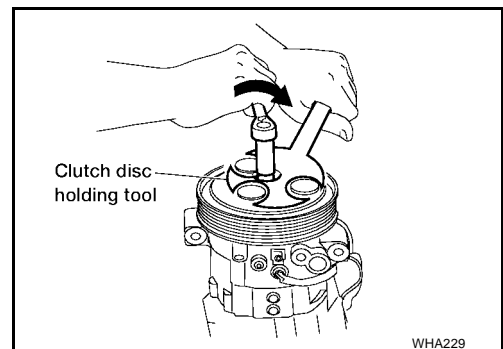

# REFRIGERANT LINES

6. Check the pulley clearance all the way around the clutch disc as shown.

**Clutch disc-to-pulley clearance : 0.3 - 0.6 mm  
(0.012 - 0.024 in)**

7. If the specified clearance is not obtained, replace the adjusting spacer to readjust.
8. Connect the compressor electrical connector.
9. Install the drive belt. Refer to [EM-12, "DRIVE BELTS"](#).
10. Install the engine under cover and the splash shield.

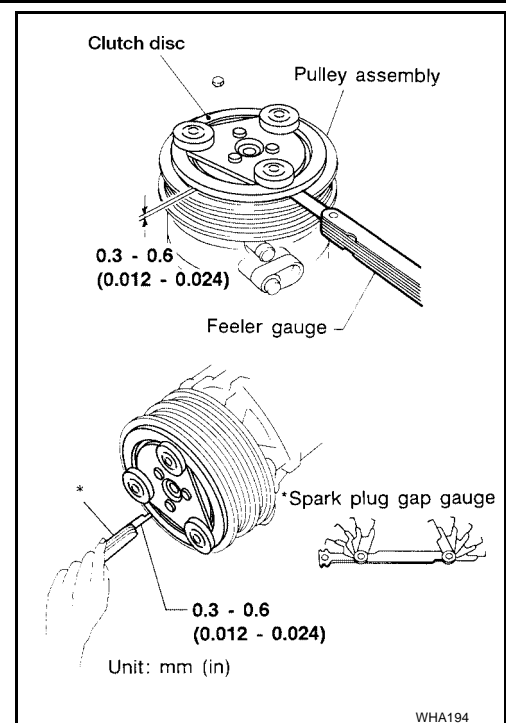

## BREAK-IN OPERATION

When replacing compressor clutch assembly, always conduct the break-in operation. This is done by engaging and disengaging the clutch about 30 times. Break-in operation raises the level of transmitted torque.

## Removal and Installation for Low-pressure Flexible Hose

EJS0033B

### REMOVAL

1. Remove the engine room cover using power tool.
2. Remove the engine air cleaner and air ducts. Refer to [EM-14, "AIR CLEANER AND AIR DUCT"](#)
3. Discharge the refrigerant. Refer to [MTC-112, "HFC-134a \(R-134a\) Service Procedure"](#).

#### **CAUTION:**

Cap or wrap the joint of the pipe with suitable material such as vinyl tape to avoid the entry of air.

4. Remove the low-pressure flexible hose.

### INSTALLATION

Installation is in the reverse order of removal.

#### **CAUTION:**

- Replace the O-ring of the low-pressure flexible hose with a new one, then apply compressor oil to it when installing it.
- After charging refrigerant, check for leaks.

## Removal and Installation for High-pressure Flexible Hose

EJS0033C

### REMOVAL

1. Remove the engine under cover using power tool.
2. Remove the engine air cleaner and air ducts. Refer to [EM-14, "AIR CLEANER AND AIR DUCT"](#)
3. Discharge the refrigerant. Refer to [MTC-112, "HFC-134a \(R-134a\) Service Procedure"](#).
4. Remove the high-pressure flexible hose.

#### **CAUTION:**

Cap or wrap the joint of the pipe with suitable material such as vinyl tape to avoid the entry of air.

### INSTALLATION

Installation is in the reverse order of removal.

#### **CAUTION:**

- Replace the O-ring of the high-pressure flexible hose with a new one, then apply compressor oil to it when installing it.

# REFRIGERANT LINES

- After charging refrigerant, check for leaks.

## Removal and Installation for High-pressure Pipe REMOVAL

EJS0033D

1. Disconnect the battery negative terminal.
2. Reposition the IPDM E/R aside.
3. Remove the front right wheel and tire assembly. Refer to [WT-6, "Rotation"](#) .
4. Position aside the front floor insulator.
5. Discharge the refrigerant. Refer to [MTC-112, "HFC-134a \(R-134a\) Service Procedure"](#) .
6. Remove the high-pressure pipe.

### CAUTION:

Cap or wrap the joint of the pipe with suitable material such as vinyl tape to avoid the entry of air.

## INSTALLATION

Installation is in the reverse order of removal.

### CAUTION:

- Replace the O-ring of the high-pressure pipe with a new one, then apply compressor oil to it when installing it.
- After charging refrigerant, check for leaks.

## Removal and Installation for Low-pressure Pipe REMOVAL

EJS0033E

1. Discharge the refrigerant. Refer to [MTC-112, "HFC-134a \(R-134a\) Service Procedure"](#) .
2. Remove the low-pressure pipe.

### CAUTION:

Cap or wrap the joint of the pipes with suitable material such as vinyl tape to avoid the entry of air.

## INSTALLATION

Installation is in the reverse order of removal.

### CAUTION:

- Replace the O-ring of the high/low-pressure pipe with a new one, then apply compressor oil to it when installing it.
- After charging refrigerant, check for leaks.

## Removal and Installation for Refrigerant Pressure Sensor REMOVAL

EJS0033F

1. Disconnect the refrigerant pressure sensor electrical connector.
2. Remove the refrigerant pressure sensor from the condenser.

### CAUTION:

Be careful not to damage the condenser fins.

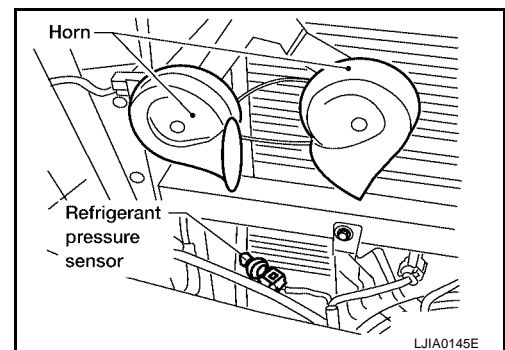

## INSTALLATION

Installation is in the reverse order of removal.

### CAUTION:

- Be careful not to damage the condenser fins.
- Apply compressor oil to the O-ring of the refrigerant pressure sensor when installing it.

## Removal and Installation for Condenser REMOVAL

EJS0033G

1. Discharge the refrigerant. Refer to [MTC-112, "HFC-134a \(R-134a\) Service Procedure"](#) .
2. Remove the radiator. Refer to [CO-12, "Removal and Installation"](#) .



# REFRIGERANT LINES

**CAUTION:**

**Be careful not to damage the core surface of the condenser and the radiator.**

3. Disconnect the high-pressure flexible hose and the high-pressure pipe from the condenser.

**CAUTION:**

**Cap or wrap the joint of the pipe with suitable material such as vinyl tape to avoid the entry of air.**

4. Disconnect the refrigerant pressure sensor connector.
  - Remove the refrigerant pressure sensor from the condenser as necessary.
5. Lift the condenser out of the mounting grommets to remove the condenser.

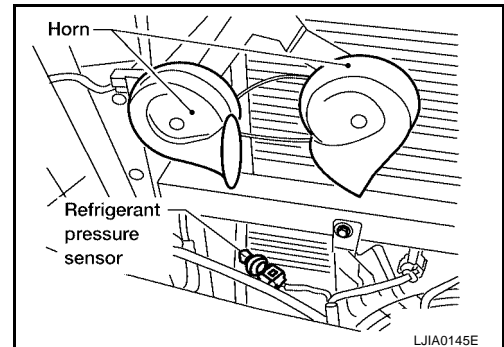

## INSTALLATION

Installation is in the reverse order of removal.

**CAUTION:**

- Replace the O-rings of the high-pressure pipe and the high-pressure flexible hose with new ones, then apply compressor oil to them after installing them.
- After charging refrigerant, check for leaks.
- Replace the grommets as necessary.

A

B

C

D

E

F

G

H

I

MTC

K

L

M

# REFRIGERANT LINES

## Removal and Installation for Evaporator

EJS0033H

### Heater and Cooling Unit Assembly

SEC. 271

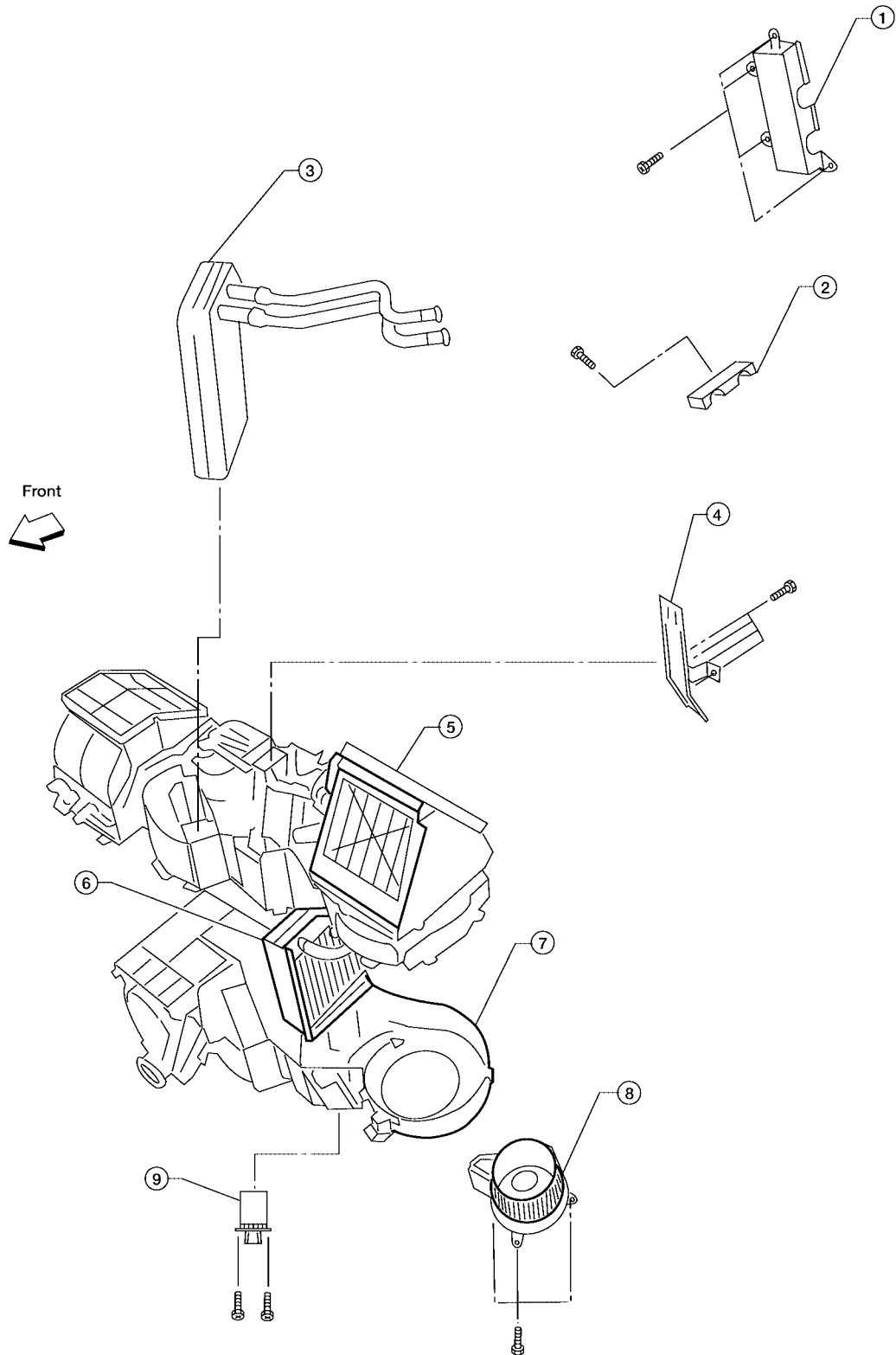

- |                                       |                                       |                            |
|---------------------------------------|---------------------------------------|----------------------------|
| 1. Heater core cover                  | 2. Heater core pipe bracket           | 3. Heater core             |
| 4. Upper bracket                      | 5. Upper heater and cooling unit case | 6. A/C evaporator          |
| 7. Lower heater and cooling unit case | 8. Blower motor                       | 9. Variable blower control |

LJIA0138E

### REMOVAL

1. Remove the heater core. Refer to [MTC-102, "Removal and Installation"](#).

# REFRIGERANT LINES

2. Remove the defroster mode door arm.
3. Separate the heater core and cooling unit case.
4. Remove the evaporator.

## INSTALLATION

Installation is in the reverse order of removal.

### CAUTION:

Replace the O-rings on the low-pressure flexible hose and the high-pressure pipe with new ones. Apply compressor oil to the O-rings before installing them.

## Removal and Installation for Expansion Valve

### REMOVAL

1. Discharge the refrigerant. Refer to [MTC-112, "HFC-134a \(R-134a\) Service Procedure"](#).
2. Remove the heater and cooling unit assembly. Refer to [MTC-100, "Removal and Installation"](#).
3. Remove the cooler grommet.
4. Remove the expansion valve.

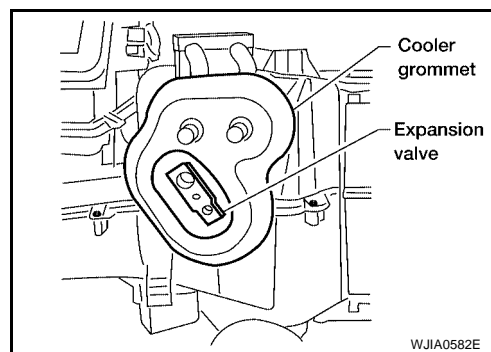

## INSTALLATION

Installation is in the reverse order of removal.

- Expansion valve bolts** : 4 N·m (0.41 kg·m, 35 in·lb)
- A/C refrigerant pipe to expansion valve bolt** : Refer to [MTC-114, "Components"](#).

### CAUTION:

- Replace the O-rings on the A/C refrigerant pipes with new ones, then apply compressor oil to them when installing them.
- After charging refrigerant, check for leaks.

## Checking for Refrigerant Leaks

Perform a visual inspection of all refrigeration parts, fittings, hoses and components for signs of A/C lubricant leakage, damage, and corrosion. Any A/C lubricant leakage may indicate an area of refrigerant leakage. Allow extra inspection time in these areas when using either an electronic refrigerant leak detector (J-41995) or fluorescent dye leak detector (J-42220).

If any dye is observed using a fluorescent dye leak detector (J-42220), confirm the leak using a electronic refrigerant leak detector (J-41995). It is possible that the dye is from a prior leak that was repaired and not properly cleaned.

When searching for leaks, do not stop when one leak is found but continue to check for additional leaks at all system components and connections.

When searching for refrigerant leaks using an electronic refrigerant leak detector (J-41995), move the probe along the suspected leak area at 25 - 50 mm (1 - 2 in) per second and no further than 6 mm (1/4 in) from the component.

### CAUTION:

Moving the electronic refrigerant leak detector probe slower and closer to the suspected leak area will improve the chances of finding a leak.

## Checking System for Leaks Using the Fluorescent Dye Leak Detector

1. Check the A/C system for leaks using the fluorescent dye leak detector and safety goggles (J-42220) in a low sunlight area (area without windows preferable). Illuminate all components, fittings and lines. The dye will appear as a bright green/yellow area at the point of leakage. Fluorescent dye observed at the evaporator drain opening indicates an evaporator core assembly leak (tubes, core or expansion valve).

# REFRIGERANT LINES

2. If the suspected area is difficult to see, use an adjustable mirror or wipe the area with a clean shop rag or cloth, then inspect the shop rag or cloth with the fluorescent dye leak detector (J-42220) for dye residue.
3. After the leak is repaired, remove any residual dye using refrigerant dye cleaner (J-43872) to prevent future misdiagnosis.
4. Perform a system performance check and then verify the leak repair using a electronic refrigerant leak detector (J-41995).

## NOTE:

- Other gases in the work area or substances on the A/C components, for example, anti-freeze, windshield washer fluid, solvents and lubricants, may falsely trigger the leak detector. Make sure the surfaces to be checked are clean.
- Clean with a dry cloth or blow off with shop air.
- Do not allow the sensor tip of the electronic refrigerant leak detector (J-41995) to contact with any substance. This can also cause false readings and may damage the detector.

## Dye Injection

EJS0033L

### NOTE:

This procedure is only necessary when recharging the system or when the compressor has seized and must be replaced.

1. Check the A/C system static (at rest) pressure. Pressure must be at least 345 kPa (3.52 kg-cm<sup>2</sup> , 50 psi).
2. Pour one bottle 7.4 cc (1/4 ounce) of the HFC-134a (R-134a) fluorescent leak detection dye (J-41447) into the HFC-134a (R-134a) dye injector (J-41459).

### CAUTION:

**If repairing the A/C system or replacing a component, pour the HFC-134a (R-134a) fluorescent leak detection dye (J-41447) directly into the open system connection and proceed with the service procedures.**

3. Connect the refrigerant dye injector (J-41459) to the low-pressure service valve.
4. Start the engine and switch the A/C system ON.
5. When the A/C system is operating (compressor running), inject one bottle 7.4 cc (1/4 ounce) of HFC-134a (R-134a) fluorescent leak detection dye (J-41447) through the low-pressure service valve using HFC-134a (R-134a) dye injector (J-41459). Refer to the manufacturer's operating instructions.
6. With the engine still running, disconnect the HFC-134a (R-134a) dye injector (J-41459) from the low-pressure service valve.
7. Operate the A/C system for a minimum of 20 minutes to mix the HFC-134a (R-134a) fluorescent leak detection dye (J-41447) with the A/C system oil. Depending on the leak size, operating conditions and location of the leak, it may take from minutes to days for the HFC-134a (R-134a) fluorescent leak detection dye to penetrate an A/C system leak and become visible.

## Electronic Refrigerant Leak Detector PRECAUTIONS FOR HANDLING LEAK DETECTOR

EJS0033M

### NOTE:

When performing a refrigerant leak check, use a electronic refrigerant leak detector (J-41995) or equivalent. Ensure that the electronic refrigerant leak detector (J-41995) is calibrated and set properly according to the manufacturer's operating instructions.

The electronic refrigerant leak detector (J-41995) is a delicate device. To use the leak detector properly, read the manufacturer's operating instructions and perform any specified maintenance.

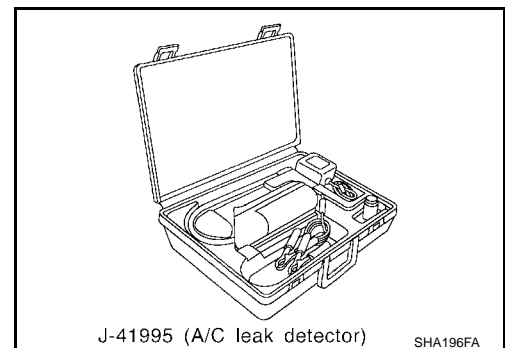

# REFRIGERANT LINES

1. Position the probe approximately 5 mm (3/16 in) away from the point to be checked as shown.

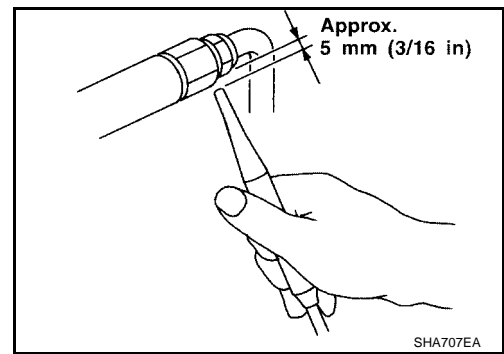

2. When checking for leaks, circle each fitting completely with the probe as shown.

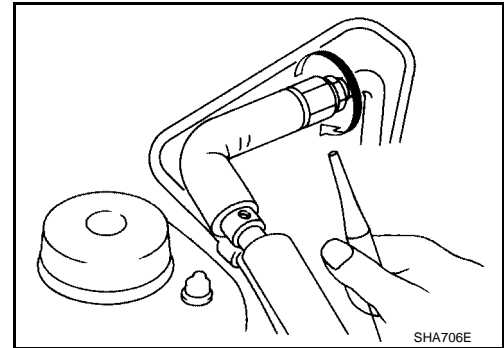

3. Move the probe along each component at a speed of approximately 25 - 50 mm (1 - 2 in)/second as shown.

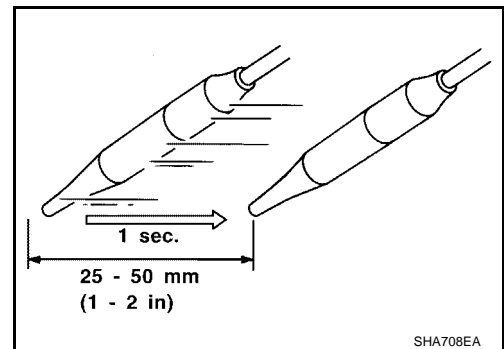

## CHECKING PROCEDURE

### NOTE:

To prevent inaccurate or false readings, make sure there is no refrigerant vapor, shop chemicals, or cigarette smoke in the vicinity of the vehicle. Perform the leak test in a calm area (low air/wind movement) so that the leaking refrigerant is not dispersed.

1. Turn the engine OFF.
2. Connect the manifold gauge set (J-39183-C) to the A/C service ports. Refer to [MTC-112, "SETTING OF SERVICE TOOLS AND EQUIPMENT"](#).
3. Check if the A/C refrigerant pressure is at least 345 kPa (3.52 kg/cm<sup>2</sup>, 50 psi) above a temperature of 16°C (61°F). If less than specification, recover/evacuate and recharge the system with the specified amount of refrigerant. Refer to [MTC-112, "HFC-134a \(R-134a\) Service Procedure"](#).

### NOTE:

At temperatures below 16°C (61°F), leaks may not be detected since the system may not reach 345 kPa (3.52 kg/cm<sup>2</sup>, 50 psi) pressure.

4. Perform the leak test from the high-pressure side (A/C compressor discharge "a" to evaporator inlet "f") to the low-pressure side (evaporator drain hose "g" to compressor shaft seal "k"). Refer to [MTC-114, "Components"](#). Clean the component to be checked and carefully move the electronic refrigerant leak detector probe completely around the following connections and components.

- Check the compressor shaft seal
- Check the high and low-pressure pipe and hose fittings, and relief valve
- Check the liquid tank

A  
B  
C  
D  
E  
F  
G  
H  
I  
MTC  
K  
L  
M

# REFRIGERANT LINES

- Check the refrigerant pressure sensor
- Check all around the service valves. Ensure service valve caps are secured on the service valves (to prevent leaks).

**NOTE:**

After removing manifold gauge set (J-39183-C) from the service valves, wipe any residue from the service valves to prevent any false readings by the electronic refrigerant leak detector (J-41995).

- Evaporator

With engine OFF, turn blower fan on "High" for at least 15 seconds to dissipate any refrigerant trace in the heater and cooling unit assembly. Wait a minimum of 10 minutes accumulation time (refer to the manufacturer's recommended procedure for actual wait time) before inserting the electronic refrigerant leak detector probe into the heater and cooling unit assembly drain hose.

**NOTE:**

Keep the probe inserted for at least 10 seconds. Use caution not to contaminate the probe tip with water or dirt that may be in the drain hose.

5. If a leak is detected, verify at least once by blowing compressed air into the area of the suspected leak, then repeat the leak check.
6. Do not stop when one leak is found. Continue to check for additional leaks at all system components and connections.
7. If no leaks are found, perform steps 8 - 11.
8. Start the engine.
9. Set the heater A/C controls as follows:

**NOTE:**

For the automatic system, turn OFF the automatic controls and set the heater A/C controls manually.

- a. A/C switch to ON
  - b. Air flow to VENT mode
  - c. Intake position to RECIRCULATION mode
  - d. Temperature to MAX cold
  - e. Blower speed to HIGH
10. Run the engine at 1,500 rpm for at least 2 minutes.
  11. Turn the engine OFF and perform the leak check again following steps 4 through 6 above.

Refrigerant leaks should be checked immediately after turning the engine OFF. Begin with the leak detector at the compressor. The pressure on the high pressure side will gradually drop after the refrigerant circulation stops and pressure on the low pressure side will gradually rise, as shown in the graph. Some leaks are more easily detected when the pressure is high.

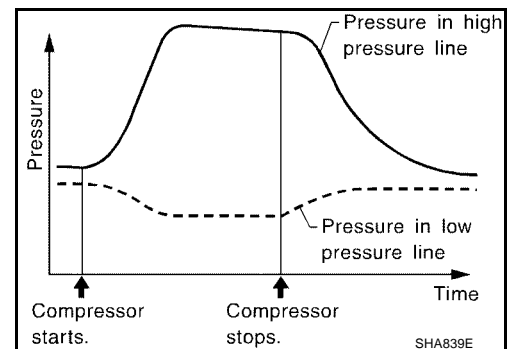

12. Before connecting the recovery/recycling recharging equipment to the vehicle, check the recovery/recycling recharging equipment gauges. No refrigerant pressure should be displayed. If pressure is displayed, recover the refrigerant from the equipment lines and then check the refrigerant purity.
13. Confirm refrigerant purity in supply tank using recovery/recycling recharging equipment and refrigerant identifier equipment (J-41810-NI).
14. Confirm the refrigerant purity in the vehicle's A/C system using recovery/recycling recharging equipment and refrigerant identifier equipment (J-41810-NI).
15. Discharge the A/C system using recovery/recycling recharging equipment. Repair the leaking fitting or component as necessary.
16. Evacuate and recharge the A/C system and perform the leak test to confirm that there are no refrigerant leaks.
17. Conduct the Operational Check to ensure system works properly. Refer to [MTC-47, "Operational Check"](#).

# SERVICE DATA AND SPECIFICATIONS (SDS)

## SERVICE DATA AND SPECIFICATIONS (SDS)

PFP:00030

### Service Data and Specifications (SDS) COMPRESSOR

EJS0033N

Make	ZEXEL VALEO CLIMATE CONTROL
Model	DKS-17D
Type	Swash plate
Displacement	175.5 cm <sup>3</sup> (10.7 in <sup>3</sup> ) / revolution
Cylinder bore × stroke	30.5 mm (1.20 in) x 24.0 mm (0.94 in)
Direction of rotation	Clockwise (viewed from drive end)
Drive belt	Poly V

### LUBRICANT

Make	ZEXEL VALEO CLIMATE CONTROL
Model	DKS-17D
Name	NISSAN A/C System Lubricant Type S (DH-PS)
Part number	KLH00-PAGS0
Capacity	200 mℓ (6.8 US fl oz, 7.0 Imp fl oz)

### REFRIGERANT

Type	HFC-134a (R-134a)
Capacity	0.70 ± 0.05 kg (1.54 ± 0.11 lb)

### ENGINE IDLING SPEED

Refer to [EC-76, "Idle Speed and Ignition Timing Check"](#) .

### BELT TENSION

Refer to [EM-12, "Tension Adjustment"](#) .

A

B

C

D

E

F

G

H

I

MTC

K

L

M

# SERVICE DATA AND SPECIFICATIONS (SDS)

---