

LT  
**SECTION**  
**LIGHTING SYSTEM**

A  
 B  
 C  
 D  
 E  
 F  
 G  
 H  
 I  
 J  
 LT  
 L  
 M

**CONTENTS**

<p><b>PRECAUTIONS</b> ..... 4</p> <p>    Precautions for Supplemental Restraint System (SRS) "AIR BAG" and "SEAT BELT PRE-TENSIONER" ..... 4</p> <p>    General precautions for service operations ..... 4</p> <p>    Wiring Diagrams and Trouble Diagnosis ..... 4</p> <p><b>HEADLAMP (FOR USA)</b> ..... 5</p> <p>    Component Parts and Harness Connector Location... 5</p> <p>    System Description ..... 5</p> <p>        OUTLINE ..... 5</p> <p>        BATTERY SAVER CONTROL ..... 6</p> <p>        AUTO LIGHT OPERATION ..... 7</p> <p>        VEHICLE SECURITY SYSTEM (PANIC ALARM)... 7</p> <p>    CAN Communication System Description ..... 7</p> <p>    Schematic ..... 8</p> <p>    Wiring Diagram — H/LAMP — ..... 9</p> <p>    Terminals and Reference Values for BCM ..... 13</p> <p>    Terminals and Reference Values for IPDM E/R .... 14</p> <p>    How to Proceed With Trouble Diagnosis ..... 14</p> <p>    Preliminary Check ..... 15</p> <p>        CHECK POWER SUPPLY AND GROUND CIRCUIT ..... 15</p> <p>    CONSULT-II Function (BCM) ..... 17</p> <p>        CONSULT-II OPERATION ..... 17</p> <p>        WORK SUPPORT ..... 18</p> <p>        DATA MONITOR ..... 18</p> <p>        ACTIVE TEST ..... 19</p> <p>        SELF-DIAGNOSTIC RESULTS ..... 19</p> <p>    CONSULT-II Function (IPDM E/R) ..... 20</p> <p>        CONSULT-II OPERATION ..... 20</p> <p>        DATA MONITOR ..... 21</p> <p>        ACTIVE TEST ..... 21</p> <p>    Headlamp HI Does Not Illuminate (Both Sides) .... 22</p> <p>    Headlamp HI Does Not Illuminate (One Side) ..... 24</p> <p>    High Beam Indicator Lamp Does Not Illuminate ... 25</p> <p>    Headlamp LO Does Not Illuminate (Both Sides) ... 25</p> <p>    Headlamp LO Does Not Illuminate (One Side) ..... 27</p> <p>    Headlamps Do Not Turn OFF ..... 28</p> <p>    Aiming Adjustment ..... 29</p> <p>        LOW BEAM AND HIGH BEAM ..... 29</p>	<p>    Bulb Replacement ..... 30</p> <p>        HEADLAMP (OUTER SIDE), FOR LOW BEAM.. 30</p> <p>        HEADLAMP (INNER SIDE), FOR HIGH BEAM.. 30</p> <p>        FRONT TURN SIGNAL/PARKING LAMP ..... 30</p> <p>        FRONT SIDE MARKER LAMP ..... 30</p> <p>    Removal and Installation ..... 31</p> <p>        REMOVAL ..... 31</p> <p>        INSTALLATION ..... 31</p> <p>    Disassembly and Assembly ..... 31</p> <p><b>HEADLAMP (FOR CANADA) - DAYTIME LIGHT SYSTEM -</b> ..... 32</p> <p>    Component Parts and Harness Connector Location.. 32</p> <p>    System Description ..... 33</p> <p>        OUTLINE ..... 33</p> <p>        DAYTIME LIGHT OPERATION ..... 33</p> <p>        COMBINATION SWITCH READING FUNCTION.. 33</p> <p>        AUTO LIGHT OPERATION ..... 33</p> <p>    CAN Communication System Description ..... 34</p> <p>    Schematic ..... 35</p> <p>    Wiring Diagram — DTRL — ..... 36</p> <p>    Terminals and Reference Values for BCM ..... 40</p> <p>    How to Proceed With Trouble Diagnosis ..... 41</p> <p>    Preliminary Check ..... 41</p> <p>        CHECK BCM CONFIGURATION ..... 41</p> <p>        INSPECTION FOR POWER SUPPLY AND GROUND CIRCUIT ..... 41</p> <p>        INSPECTION PARKING BRAKE SWITCH CIRCUIT ..... 42</p> <p>    CONSULT-II Functions ..... 43</p> <p>    Daytime Light Control Does Not Operate Properly (Normal Headlamps Operate Properly) ..... 43</p> <p>    Aiming Adjustment ..... 45</p> <p>    Bulb Replacement ..... 45</p> <p>    Removal and Installation ..... 45</p> <p>    Disassembly and Assembly ..... 45</p> <p><b>AUTO LIGHT SYSTEM</b> ..... 46</p> <p>    Component Parts and Harness Connector Location.. 46</p> <p>    System Description ..... 47</p> <p>        OUTLINE ..... 47</p> <p>        COMBINATION SWITCH READING FUNCTION.. 47</p>
--	---

EXTERIOR LAMP BATTERY SAVER CONTROL ..	47	COMBINATION SWITCH READING FUNCTION ..	77
DELAY TIMER FUNCTION .....	47	CAN Communication System Description .....	77
CAN Communication System Description .....	47	Wiring Diagram — TURN — .....	78
Major Components and Functions .....	47	Terminals and Reference Values for BCM .....	80
Schematic .....	48	How to Proceed With Trouble Diagnosis .....	81
Wiring Diagram — AUTO/L — .....	49	Preliminary Check .....	82
Terminals and Reference Values for BCM .....	52	CHECK POWER SUPPLY AND GROUND CIR-	
Terminals and Reference Values for IPDM E/R .....	53	CUIT .....	82
How to Proceed With Trouble Diagnosis .....	54	CONSULT-II Function (BCM) .....	83
Preliminary Check .....	54	CONSULT-II OPERATION .....	83
SETTING CHANGE FUNCTIONS .....	54	DATA MONITOR .....	84
CHECK BCM CONFIGURATION .....	54	ACTIVE TEST .....	84
CHECK POWER SUPPLY AND GROUND CIR-		Turn Signal Lamp Does Not Operate .....	85
CUIT .....	54	Rear Turn Signal Lamp Does Not Operate .....	86
CONSULT-II Function (BCM) .....	56	Hazard Warning Lamp Does Not Operate But Turn	
CONSULT-II OPERATION .....	56	Signal Lamps Operate .....	87
WORK SUPPORT .....	57	Turn Signal Indicator Lamp Does Not Operate .....	88
DATA MONITOR .....	57	Bulb Replacement (Front Turn Signal Lamp) .....	89
ACTIVE TEST .....	58	Bulb Replacement (Rear Turn Signal Lamp) .....	89
SELF-DIAGNOSTIC RESULTS .....	58	Removal and Installation of Front Turn Signal Lamp ..	89
CONSULT-II Function (IPDM E/R) .....	59	Removal and Installation of Rear Turn Signal Lamp ..	89
CONSULT-II OPERATION .....	59	<b>LIGHTING AND TURN SIGNAL SWITCH .....</b>	<b>90</b>
DATA MONITOR .....	60	Removal and Installation .....	90
ACTIVE TEST .....	60	REMOVAL .....	90
Trouble Diagnosis Chart by Symptom .....	61	INSTALLATION .....	90
Lighting Switch Inspection .....	61	<b>HAZARD SWITCH .....</b>	<b>91</b>
Optical Sensor System Inspection .....	62	Removal and Installation .....	91
Removal and Installation of Optical Sensor .....	63	REMOVAL .....	91
REMOVAL .....	63	INSTALLATION .....	91
INSTALLATION .....	63	<b>COMBINATION SWITCH .....</b>	<b>92</b>
<b>FRONT FOG LAMP .....</b>	<b>64</b>	Wiring Diagram — COMBSW — .....	92
Component Parts and Harness Connector Location ..	64	Combination Switch Reading Function .....	93
System Description .....	64	CONSULT-II Function (BCM) .....	93
OUTLINE .....	64	CONSULT-II OPERATION .....	93
COMBINATION SWITCH READING FUNCTION ..	65	DATA MONITOR .....	94
EXTERIOR LAMP BATTERY SAVER CONTROL ..	65	Combination Switch Inspection .....	95
CAN Communication System Description .....	65	Removal and Installation .....	97
Wiring Diagram — F/FOG — .....	66	Switch Circuit Inspection .....	97
Terminals and Reference Values for BCM .....	68	<b>STOP LAMP .....</b>	<b>98</b>
Terminals and Reference Values for IPDM E/R .....	69	System Description .....	98
How to Proceed With Trouble Diagnosis .....	69	Wiring Diagram — STOP/L — .....	99
Preliminary Check .....	70	High-Mounted Stop Lamp .....	101
CHECK BCM CONFIGURATION .....	70	BULB REPLACEMENT .....	101
CHECK POWER SUPPLY AND GROUND CIR-		REMOVAL AND INSTALLATION .....	101
CUIT .....	70	Stop Lamp .....	101
CONSULT-II Functions .....	71	BULB REPLACEMENT .....	101
Front Fog Lamps Do Not Illuminate (Both Sides) ...	71	REMOVAL AND INSTALLATION .....	101
Front Fog Lamp Does Not Illuminate (One Side) ...	72	<b>BACK-UP LAMP .....</b>	<b>102</b>
Aiming Adjustment .....	73	Wiring Diagram — BACK/L — .....	102
Bulb Replacement .....	74	Bulb Replacement .....	103
Removal and Installation .....	74	Removal and Installation .....	103
<b>TURN SIGNAL AND HAZARD WARNING LAMPS ..</b>	<b>75</b>	<b>PARKING, LICENSE PLATE AND TAIL LAMPS ...</b>	<b>104</b>
Component Parts and Harness Connector Location ..	75	Component Parts and Harness Connector Location ..	104
System Description .....	75	System Description .....	104
OUTLINE .....	75	OPERATION BY LIGHTING SWITCH .....	105
TURN SIGNAL OPERATION .....	75	COMBINATION SWITCH READING FUNCTION ..	105
HAZARD LAMP OPERATION .....	76	EXTERIOR LAMP BATTERY SAVER CONTROL ..	105
REMOTE KEYLESS ENTRY SYSTEM OPERA-		CAN Communication System Description .....	105
TION .....	76	Schematic .....	106

Wiring Diagram — TAIL/L — .....	107	INTERIOR LAMP BATTERY SAVER CONTROL	129	
Terminals and Reference Values for BCM .....	110	Schematic .....	131	A
Terminals and Reference Values for IPDM E/R ...	111	Wiring Diagram — INT/L — .....	134	
How to Proceed With Trouble Diagnosis .....	111	Terminals and Reference Values for BCM .....	142	
Preliminary Check .....	112	How to Proceed With Trouble Diagnosis .....	143	B
CHECK POWER SUPPLY AND GROUND CIR-		Preliminary Check .....	143	
CUIT .....	112	INSPECTION FOR POWER SUPPLY AND		
CONSULT-II Functions .....	113	GROUND CIRCUIT .....	143	C
Parking, License Plate and/or Tail Lamps Do Not		CONSULT-II Function (BCM) .....	144	
Illuminate .....	113	CONSULT-II OPERATION .....	144	
Parking, License Plate and Tail Lamps Do Not Turn		WORK SUPPORT .....	145	
OFF (After Approx. 10 Minutes) .....	116	DATA MONITOR .....	145	D
Front Parking Lamp .....	117	ACTIVE TEST .....	146	
BULB REPLACEMENT .....	117	Front Room/Map Lamp Assembly Control Does Not		
Tail Lamp .....	117	Operate .....	146	E
BULB REPLACEMENT .....	117	Personal Lamp 2nd Row Control Does Not Operate		
<b>REAR COMBINATION LAMP .....</b>	<b>118</b>	(Room/Map Lamps Operate) .....	148	
Bulb Replacement .....	118	All Step/Foot/Puddle Lamps Do Not Operate .....	149	F
Removal and Installation .....	118	All Interior Room Lamps Do Not Operate .....	150	
.....	118	<b>ILLUMINATION .....</b>	<b>151</b>	
<b>TRAILER TOW .....</b>	<b>119</b>	Component Parts and Harness Connector Location	151	G
Component Parts and Harness Connector Location	119	System Description .....	151	
System Description .....	119	ILLUMINATION OPERATION BY LIGHTING		
TRAILER TAIL LAMP OPERATION .....	120	SWITCH .....	152	
TRAILER TURN SIGNAL AND HAZARD LAMP		EXTERIOR LAMP BATTERY SAVER CONTROL	153	H
OPERATION .....	120	CAN Communication System Description .....	153	
TRAILER STOP LAMP OPERATION .....	120	Schematic .....	154	
TRAILER POWER SUPPLY OPERATION .....	120	Wiring Diagram — ILL — .....	157	I
Schematic .....	122	Removal and Installation of Illumination Control		
Wiring Diagram — T/TOW — .....	123	Switch .....	166	
<b>INTERIOR ROOM LAMP .....</b>	<b>126</b>	REMOVAL .....	166	J
Component Parts and Harness Connector Location	126	INSTALLATION .....	166	
System Description .....	127	<b>BULB SPECIFICATIONS .....</b>	<b>167</b>	
POWER SUPPLY AND GROUND .....	127	Headlamp .....	167	
SWITCH OPERATION .....	128	Exterior Lamp .....	167	LT
ROOM LAMP TIMER OPERATION .....	129	Interior Lamp/Illumination .....	167	

# PRECAUTIONS

## PRECAUTIONS

PFP:00011

### Precautions for Supplemental Restraint System (SRS) “AIR BAG” and “SEAT BELT PRE-TENSIONER”

EKS00A8S

The Supplemental Restraint System such as “AIR BAG” and “SEAT BELT PRE-TENSIONER”, used along with a front seat belt, helps to reduce the risk or severity of injury to the driver and front passenger for certain types of collision. This system includes seat belt switch inputs and dual stage front air bag modules. The SRS system uses the seat belt switches to determine the front air bag deployment, and may only deploy one front air bag, depending on the severity of a collision and whether the front occupants are belted or unbelted. Information necessary to service the system safely is included in the SRS and SB section of this Service Manual.

#### **WARNING:**

- To avoid rendering the SRS inoperative, which could increase the risk of personal injury or death in the event of a collision which would result in air bag inflation, all maintenance must be performed by an authorized NISSAN/INFINITI dealer.
- Improper maintenance, including incorrect removal and installation of the SRS, can lead to personal injury caused by unintentional activation of the system. For removal of Spiral Cable and Air Bag Module, see the SRS section.
- Do not use electrical test equipment on any circuit related to the SRS unless instructed to in this Service Manual. SRS wiring harnesses can be identified by yellow and/or orange harnesses or harness connectors.

### General precautions for service operations

EKS00A8T

- Never work with wet hands.
- Turn the lighting switch OFF before disconnecting and connecting the connector.
- When checking the headlamp on/off operation, check it on vehicle and with the power connected to the vehicle-side connector.
- Do not touch the headlamp bulb glass surface with bare hands or allow oil or grease to get on it. Do not touch the headlamp bulb just after the headlamp is turned off, because it is very hot.
- When the bulb has burned out, wrap it in a thick vinyl bag and discard. Do not break the bulb.
- Leaving the bulb removed from the headlamp housing for a long period of time can deteriorate the performance of the lens and reflector (dirt, clouding). Always prepare a new bulb and have it on hand when replacing the bulb.
- Do not use organic solvent (paint thinner or gasoline) to clean lamps and to remove old sealant.

### Wiring Diagrams and Trouble Diagnosis

EKS00A8U

When you read wiring diagrams, refer to the following:

- Refer to [GI-14, "How to Read Wiring Diagrams"](#) in GI section.
- Refer to [PG-4, "POWER SUPPLY ROUTING CIRCUIT"](#) for power distribution in PG section.

When you perform trouble diagnosis, refer to the following:

- Refer to [GI-11, "HOW TO FOLLOW TEST GROUPS IN TROUBLE DIAGNOSES"](#) in GI section.
- Refer to [GI-27, "How to Perform Efficient Diagnosis for an Electrical Incident"](#) in GI section.

# HEADLAMP (FOR USA)

PFP:26010

EKS00A8V

## HEADLAMP (FOR USA)

### Component Parts and Harness Connector Location

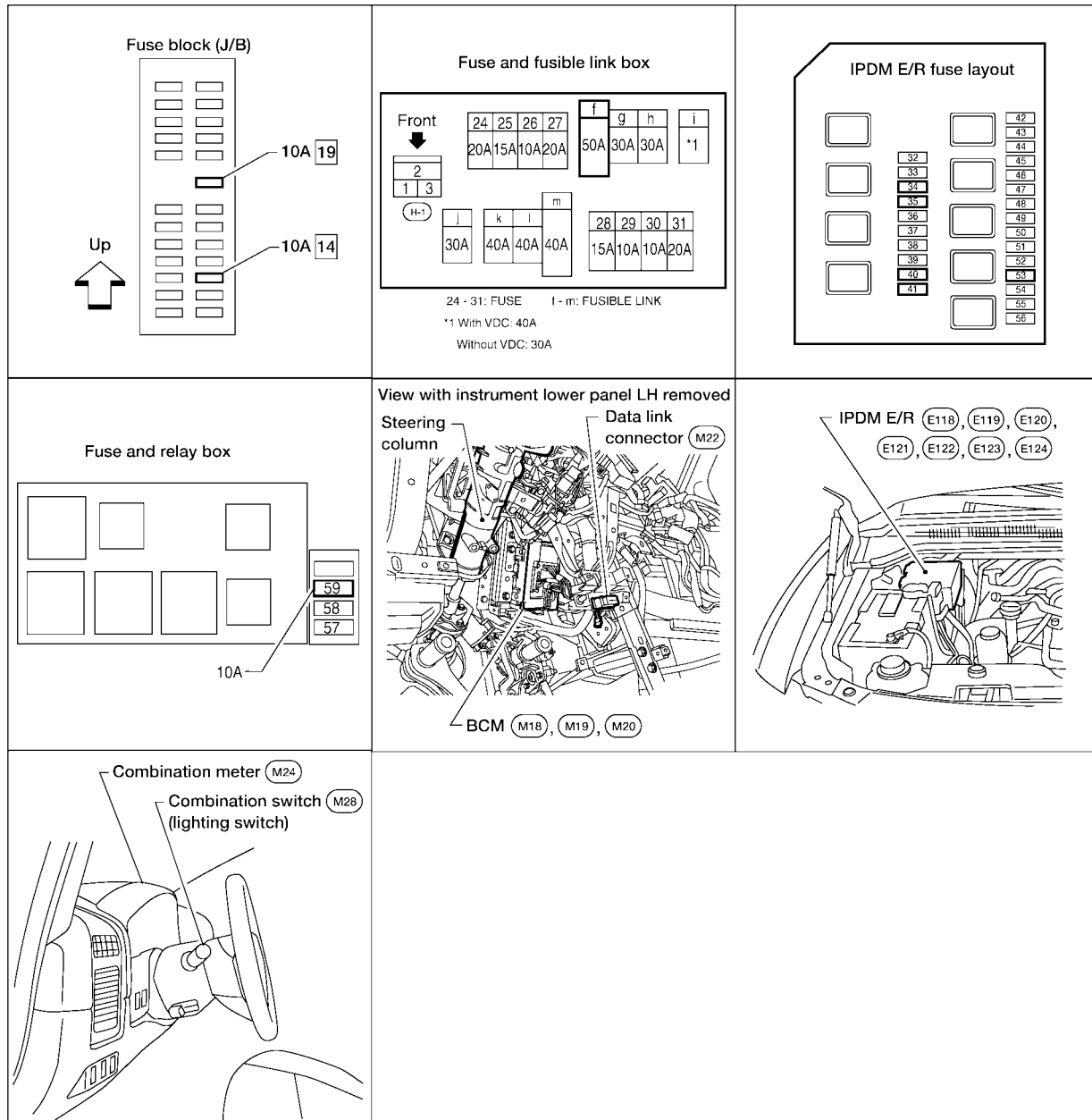

WKIA3579E

EKS00A8W

## System Description

Control of the headlamp system operation is dependent upon the position of the combination switch (lighting switch). When the lighting switch is placed in the 2ND position, the BCM (body control module) receives input requesting the headlamps (and tail lamps) illuminate. This input is communicated to the IPDM E/R (intelligent power distribution module engine room) across the CAN communication lines. The CPU (central processing unit) of the IPDM E/R controls the headlamp high and headlamp low relay coils. When energized, these relays direct power to the respective headlamps, which then illuminate.

## OUTLINE

Power is supplied at all times

- to ignition relay, located in the IPDM E/R, and

## HEADLAMP (FOR USA)

---

- to headlamp high relay, located in the IPDM E/R, and
- to headlamp low relay, located in the IPDM E/R, and
- through 20A fuse (No. 53, located in the IPDM E/R)
- to CPU of the IPDM E/R, and
- through 50A fusible link (letter f , located in the fuse and fusible link box)
- to BCM terminal 70.

With the ignition switch in the ON or START position, power is supplied

- to ignition relay, located in the IPDM E/R, and
- through 10A fuse (No. 59, located in the fuse and relay box)
- to BCM terminal 38.

Ground is supplied

- to BCM terminal 67
- through grounds M57, M61 and M79, and
- to IPDM E/R terminals 38 and 59
- through grounds E9, E15 and E24.

### Low Beam Operation

With the lighting switch in 2ND position, the BCM receives input requesting the headlamps to illuminate. This input is communicated to the IPDM E/R across the CAN communication lines. The CPU of the IPDM E/R controls the headlamp low relay coil. When energized, this relay directs power

- through 15A fuse (No. 41, located in the IPDM E/R)
- through IPDM E/R terminal 54
- to front combination lamp RH terminal 1, and
- through 15A fuse (No. 40, located in the IPDM E/R)
- through IPDM E/R terminal 52
- to front combination lamp LH terminal 1.

Ground is supplied

- to front combination lamp LH and RH terminal 4
- through grounds E9, E15 and E24.

With power and ground supplied, low beam headlamps illuminate.

### High Beam Operation/Flash-to-Pass Operation

With the lighting switch in 2ND position and placed in HIGH or PASS position, the BCM receives input requesting the headlamp high beams to illuminate. This input is communicated to the IPDM E/R across the CAN communication lines. The CPU of the combination meter controls the ON/OFF status of the HIGH BEAM indicator. The CPU of the IPDM E/R controls the headlamp high relay coil. When energized, this relay directs power

- through 10A fuse (No. 34, located in the IPDM E/R)
- through IPDM E/R terminal 56
- to front combination lamp RH terminal 2, and
- through 10A fuse (No. 35, located in the IPDM E/R)
- through IPDM E/R terminal 55
- to front combination lamp LH terminal 2.

Ground is supplied

- to front combination lamp LH and RH terminal 3
- through grounds E9, E15 and E24.

With power and ground supplied, the high beam headlamps illuminate.

### BATTERY SAVER CONTROL

When the combination switch (lighting switch) is in the 2ND position (ON), and the ignition switch is turned from ON or ACC to OFF, the battery saver control feature is activated.

Under this condition, the headlamps remain illuminated for 5 minutes, unless the combination switch (lighting switch) position is changed. If the combination switch (lighting switch) position is changed, then the headlamps are turned off.

# HEADLAMP (FOR USA)

---

## AUTO LIGHT OPERATION

Refer to [LT-47, "System Description"](#) for auto light operation.

A

## VEHICLE SECURITY SYSTEM (PANIC ALARM)

The vehicle security system (panic alarm) will flash the high beams if the system is triggered. Refer to [BL-57, "Panic Alarm Operation"](#).

B

## CAN Communication System Description

EKS00A8X

Refer to [LAN-7, "CAN COMMUNICATION"](#).

C

D

E

F

G

H

I

J

LT

L

M

# HEADLAMP (FOR USA)

## Schematic

EKS00A8Y

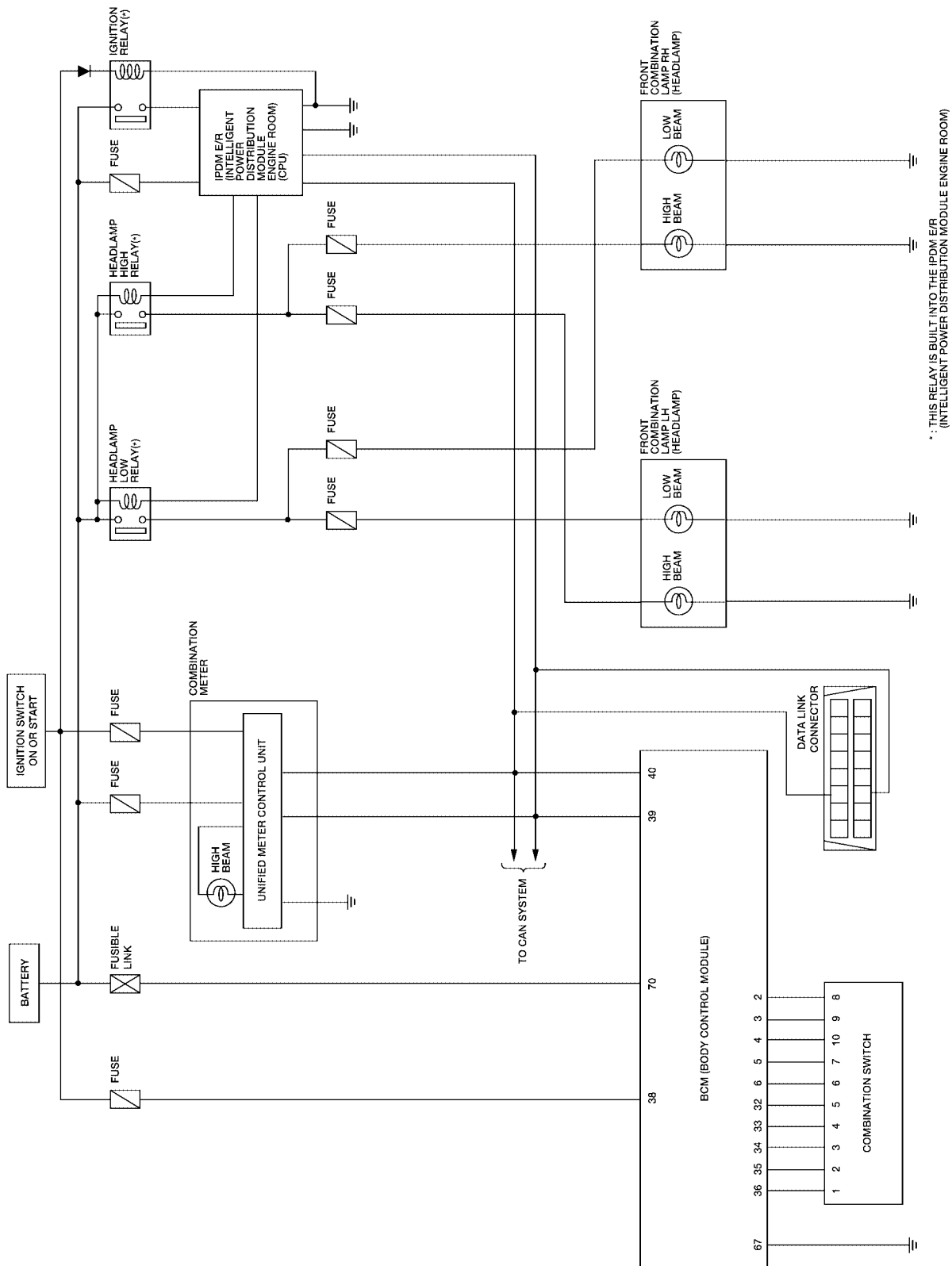

WKWA2393E



# HEADLAMP (FOR USA)

## Wiring Diagram — H/LAMP —

EKS00A8Z

LT-H/LAMP-01

— : DATA LINE

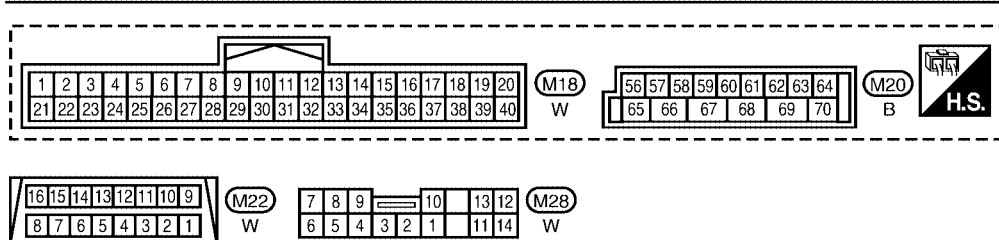
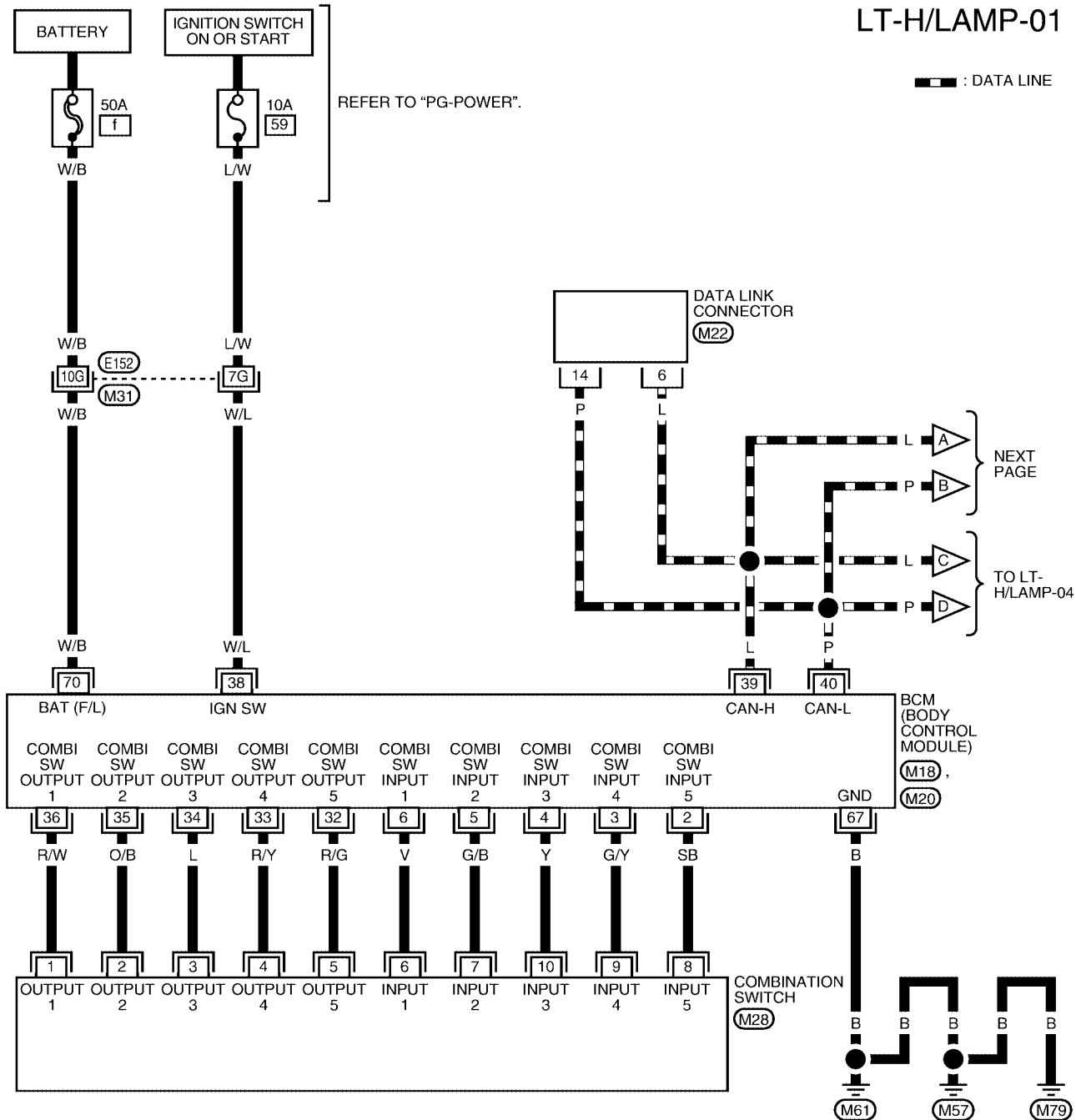

WKWA2394E

# HEADLAMP (FOR USA)

LT-H/LAMP-02

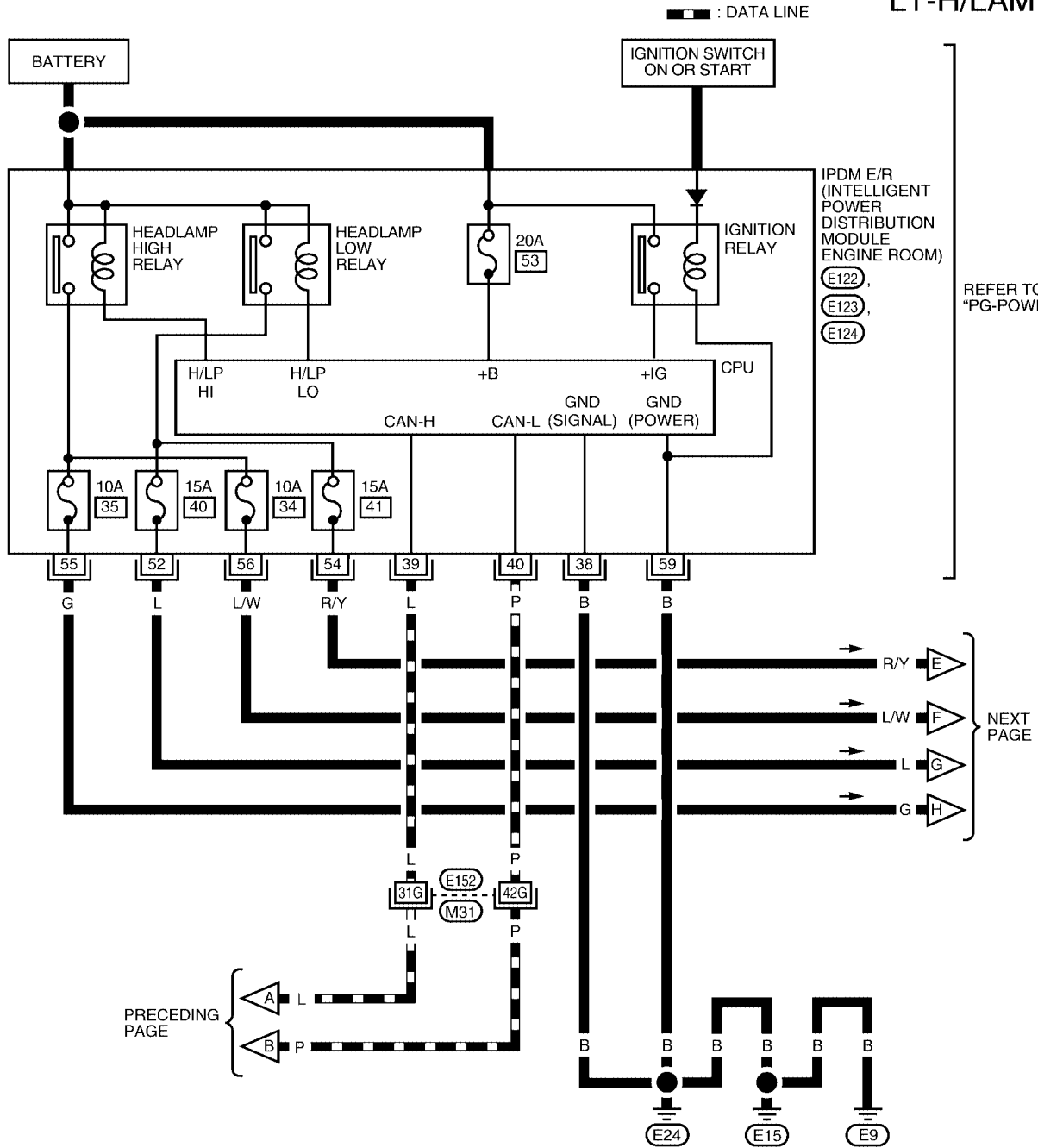

REFER TO "PG-POWER".

NEXT PAGE

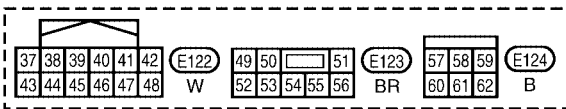

REFER TO THE FOLLOWING.  
 (M31) - SUPER MULTIPLE JUNCTION (SMJ)

WKWA2395E

# HEADLAMP (FOR USA)

LT-H/LAMP-03

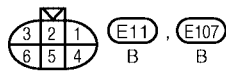
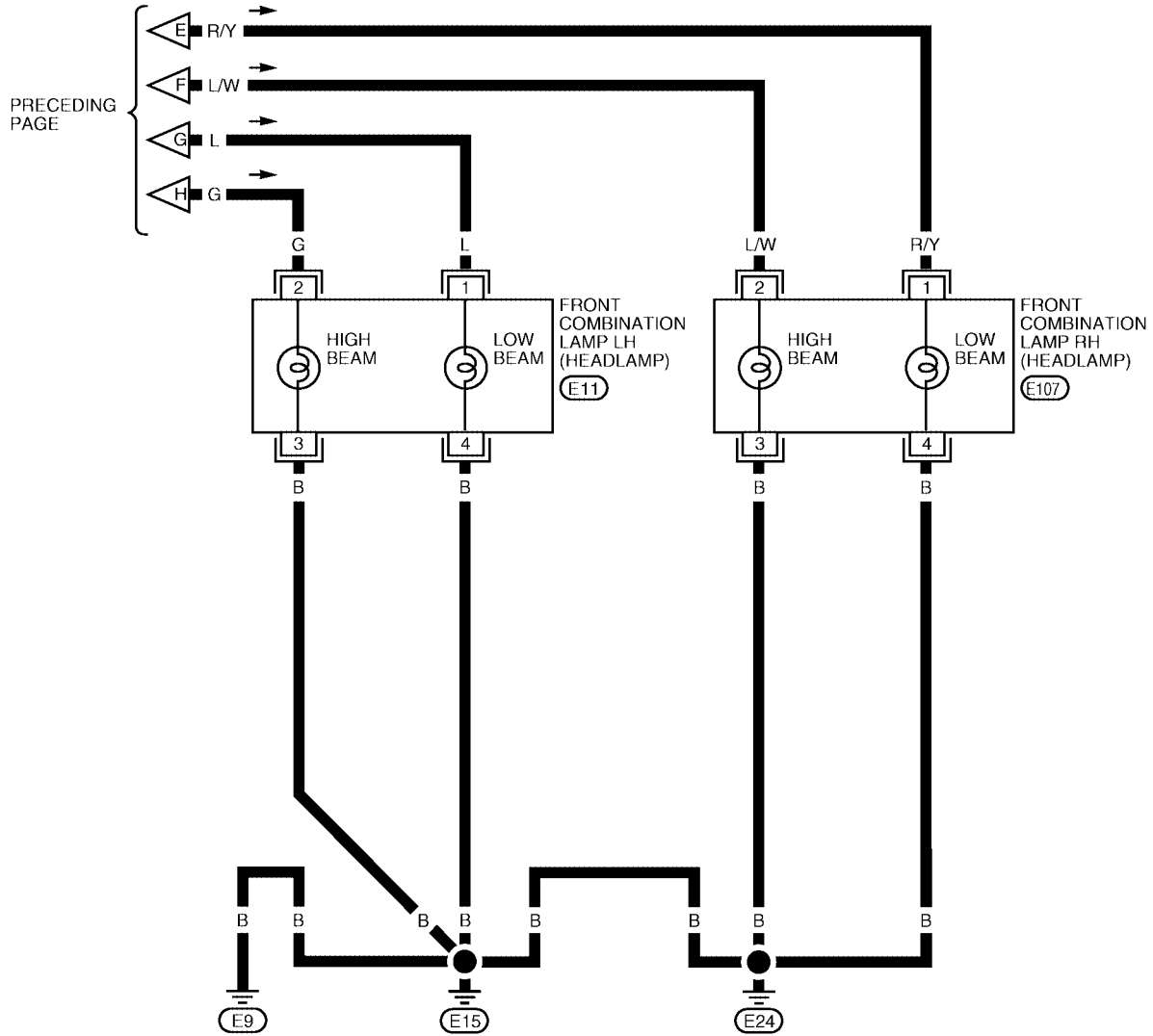

WKWA1475E

# HEADLAMP (FOR USA)

LT-H/LAMP-04

— : DATA LINE

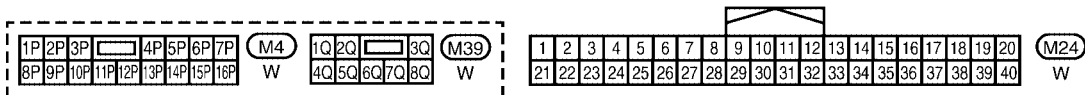
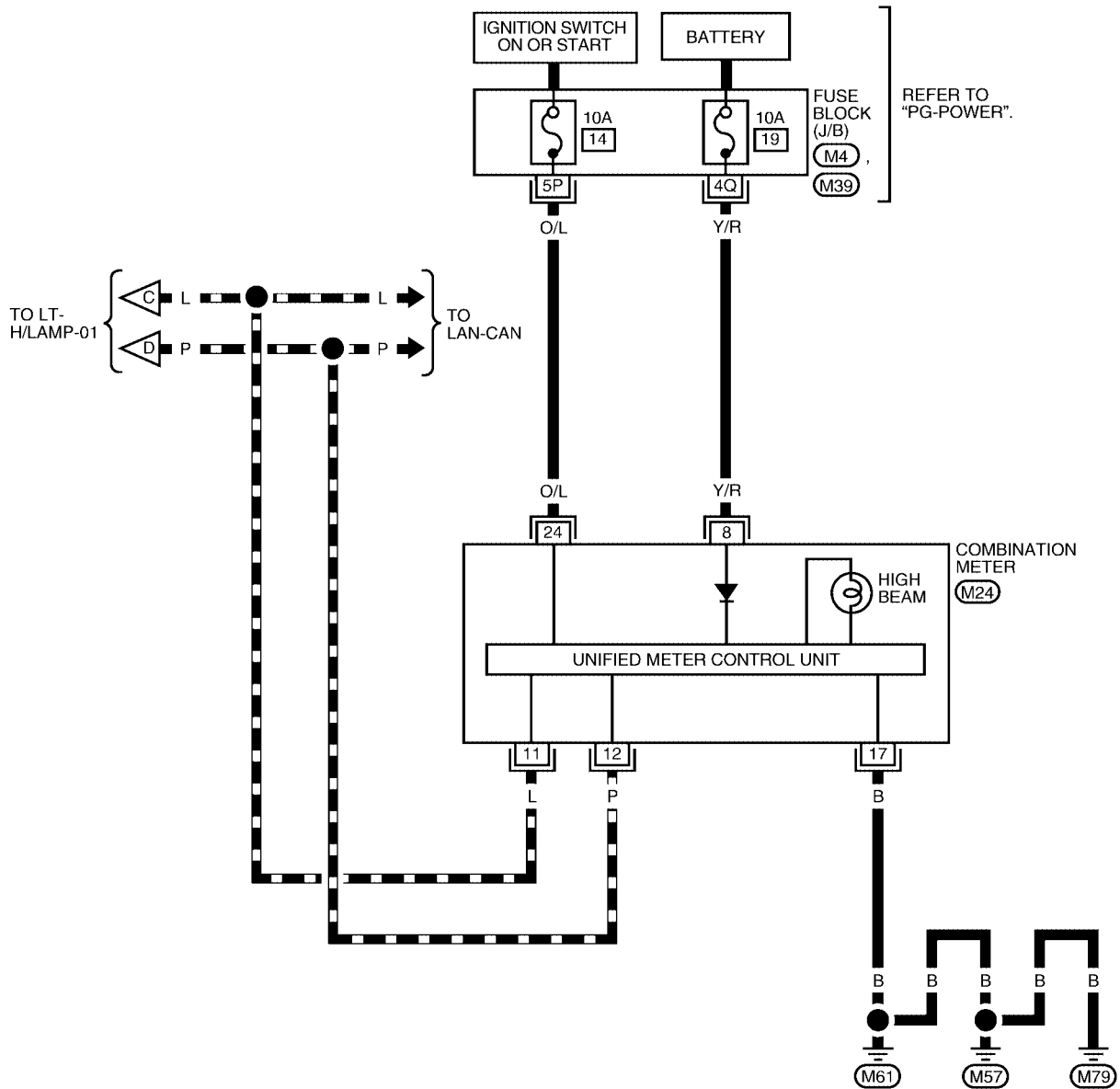

WKWA2396E

# HEADLAMP (FOR USA)

## Terminals and Reference Values for BCM

EKS00A90

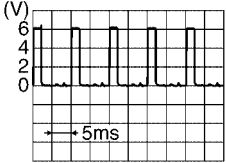
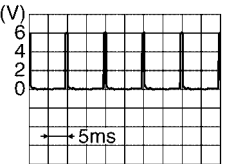
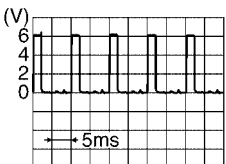
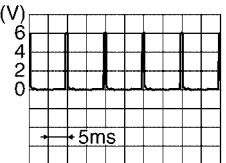
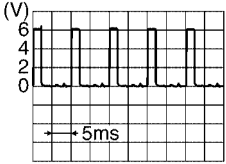
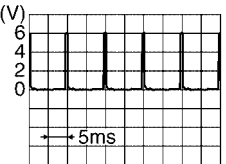
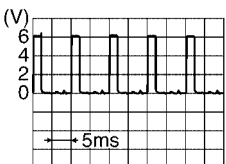
Terminal No.	Wire color	Signal name	Measuring condition		Reference value (Approx.)
			Ignition switch	Operation or condition	
2	SB	Combination switch input 5	ON	Lighting, turn, wiper OFF Wiper dial position 4	 <p style="text-align: right; font-size: small;">SKIA5291E</p>
3	G/Y	Combination switch input 4	ON	Lighting, turn, wiper OFF Wiper dial position 4	 <p style="text-align: right; font-size: small;">SKIA5292E</p>
4	Y	Combination switch input 3	ON	Lighting, turn, wiper OFF Wiper dial position 4	 <p style="text-align: right; font-size: small;">SKIA5291E</p>
5	G/B	Combination switch input 2	ON	Lighting, turn, wiper OFF Wiper dial position 4	 <p style="text-align: right; font-size: small;">SKIA5292E</p>
6	V	Combination switch input 1			
32	R/G	Combination switch output 5	ON	Lighting, turn, wiper OFF Wiper dial position 4	 <p style="text-align: right; font-size: small;">SKIA5291E</p>
33	R/Y	Combination switch output 4	ON	Lighting, turn, wiper OFF Wiper dial position 4	 <p style="text-align: right; font-size: small;">SKIA5292E</p>
34	L	Combination switch output 3	ON	Lighting, turn, wiper OFF Wiper dial position 4	 <p style="text-align: right; font-size: small;">SKIA5291E</p>

A  
B  
C  
D  
E  
F  
G  
H  
I  
J  
LT  
L  
M

# HEADLAMP (FOR USA)

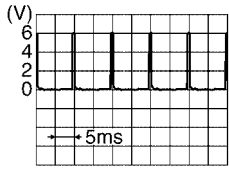
Terminal No.	Wire color	Signal name	Measuring condition		Reference value (Approx.)
			Ignition switch	Operation or condition	
35	O/B	Combination switch output 2	ON	Lighting, turn, wiper OFF Wiper dial position 4	
36	R/W	Combination switch output 1			
38	W/L	Ignition switch (ON)	ON	—	Battery voltage
39	L	CAN-H	—	—	—
40	P	CAN-L	—	—	—
67	B	Ground	ON	—	0V
70	W/B	Battery power supply (fusible link)	OFF	—	Battery voltage

## Terminals and Reference Values for IPDM E/R

EKS00A91

Terminal No.	Wire color	Signal name	Measuring condition		Reference value (Approx.)	
			Ignition switch	Operation or condition		
38	B	Ground	ON	—	0V	
39	L	CAN-H	—	—	—	
40	P	CAN-L	—	—	—	
52	L	Headlamp low (LH)	ON	Lighting switch 2ND position	OFF	0V
					ON	Battery voltage
54	R/Y	Headlamp low (RH)	ON	Lighting switch 2ND position	OFF	0V
					ON	Battery voltage
55	G	Headlamp high (LH)	ON	Lighting switch HIGH or PASS position	OFF	0V
					ON	Battery voltage
56	L/W	Headlamp high (RH)	ON	Lighting switch HIGH or PASS position	OFF	0V
					ON	Battery voltage
59	B	Ground	ON	—	0V	

## How to Proceed With Trouble Diagnosis

EKS00A92

1. Confirm the symptom or customer complaint.
2. Understand operation description and function description. Refer to [LT-5, "System Description"](#) .
3. Perform the Preliminary Check. Refer to [LT-15, "Preliminary Check"](#) .
4. Check symptom and repair or replace the cause of malfunction.
5. Does the headlamp operate normally? If YES: GO TO 6. If NO: GO TO 4.
6. Inspection End.

# HEADLAMP (FOR USA)

## Preliminary Check CHECK POWER SUPPLY AND GROUND CIRCUIT

EKS00A93

### 1. CHECK FUSES OR FUSIBLE LINK

Check for blown fuses or fusible link.

Unit	Power source	Fuse No.
BCM	Battery	f
	Ignition switch ON or START position	59
IPDM E/R	Battery	34
		35
		40
		41
		53

Refer to [LT-9, "Wiring Diagram — H/LAMP —"](#).

OK or NG

OK >> GO TO 2.

NG >> If fuse is blown, be sure to eliminate cause of malfunction before installing new fuse. Refer to [PG-4, "POWER SUPPLY ROUTING CIRCUIT"](#).

### 2. CHECK POWER SUPPLY CIRCUIT

1. Disconnect BCM connectors.
2. Check voltage between BCM harness connector and ground.

Terminals		(-)	Ignition switch position		
(+)			OFF	ACC	ON
Connector	Terminal (Wire color)	Ground	0V	0V	Battery voltage
M18	38 (W/L)		Battery voltage	Battery voltage	Battery voltage
M20	70 (W/B)				

OK or NG

OK >> GO TO 3.

NG >> Check harness for open between BCM and fuse.

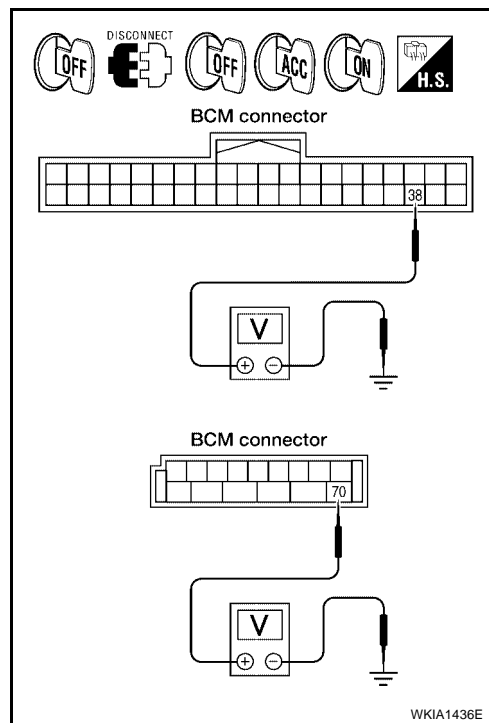

# HEADLAMP (FOR USA)

## 3. CHECK GROUND CIRCUIT

Check continuity between BCM harness connector and ground.

Terminals		Continuity
Connector	Terminal (Wire color)	
M20	67 (B)	Ground Yes

OK or NG

- OK >> Inspection End.
- NG >> Check ground circuit harness.

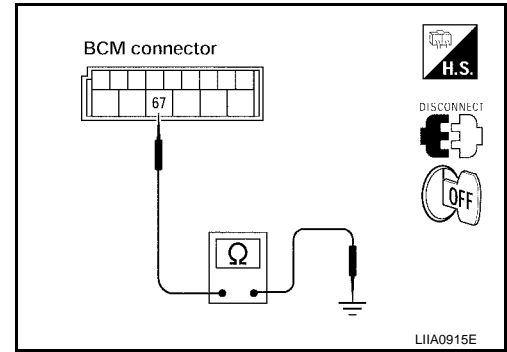



# HEADLAMP (FOR USA)

## CONSULT-II Function (BCM)

EKS00A94

CONSULT-II can display each diagnostic item using the diagnostic test modes shown following.

BCM diagnostic test item	Diagnostic mode	Description
Inspection by part	WORK SUPPORT	Supports inspections and adjustments. Commands are transmitted to the BCM for setting the status suitable for required operation, input/output signals are received from the BCM and received data is displayed.
	DATA MONITOR	Displays BCM input/output data in real time.
	ACTIVE TEST	Operation of electrical loads can be checked by sending drive signal to them.
	SELF-DIAG RESULTS	Displays BCM self-diagnosis results.
	CAN DIAG SUPPORT MNTR	The result of transmit/receive diagnosis of CAN communication can be read.
	ECU PART NUMBER	BCM part number can be read.
	CONFIGURATION	Performs BCM configuration read/write functions.

## CONSULT-II OPERATION

### CAUTION:

If CONSULT-II is used with no connection of CONSULT-II CONVERTER, malfunctions might be detected in self-diagnosis depending on control unit which carries out CAN communication.

1. With the ignition switch OFF, connect CONSULT-II and CONSULT-II CONVERTER to the data link connector, then turn ignition switch ON.

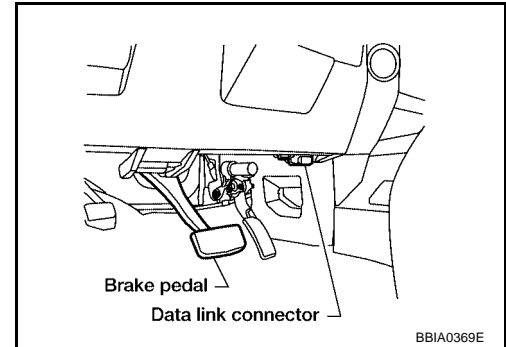

2. Touch "START (NISSAN BASED VHCL)".

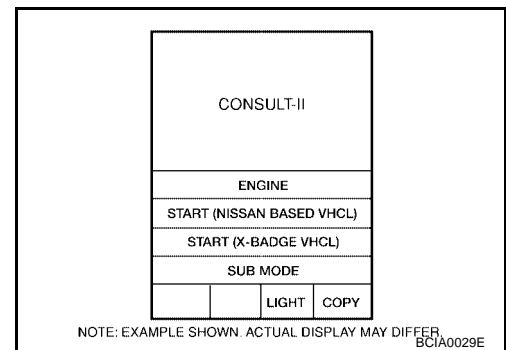

3. Touch "BCM" on "SELECT SYSTEM" screen. If "BCM" is not indicated, go to [GI-38, "CONSULT-II Data Link Connector \(DLC\) Circuit"](#).

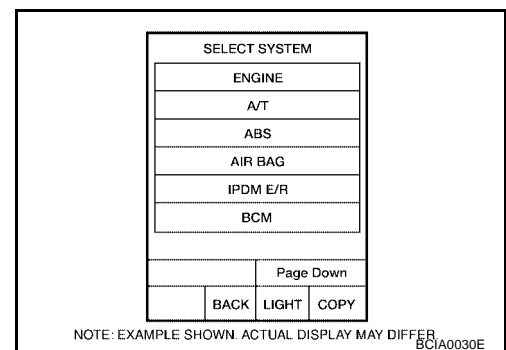

# HEADLAMP (FOR USA)

4. Touch "HEAD LAMP" on "SELECT TEST ITEM" screen.

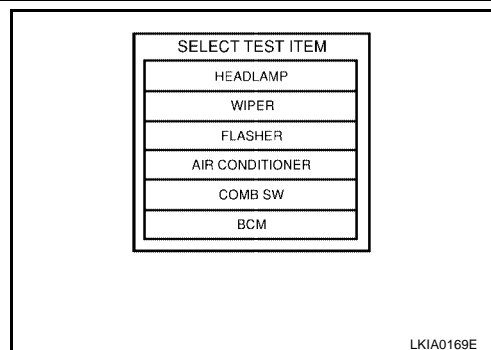

## WORK SUPPORT

### Operation Procedure

1. Touch "HEAD LAMP" on "SELECT TEST ITEM" screen.
2. Touch "WORK SUPPORT" on "SELECT DIAG MODE" screen.
3. Touch item on "SELECT WORK ITEM" screen.
4. Touch "START".
5. Touch "CHANGE SETT".
6. The setting will be changed and "CUSTOMIZING COMPLETED" will be displayed.
7. Touch "END".

### Display Item List

Item	Description	CONSULT-II	Factory setting
BATTERY SAVER SET	Exterior lamp battery saver control mode can be changed in this mode. Selects exterior lamp battery saver control mode between ON/OFF.	ON	×
		OFF	—

## DATA MONITOR

### Operation Procedure

1. Touch "HEAD LAMP" on "SELECT TEST ITEM" screen.
2. Touch "DATA MONITOR" on "SELECT DIAG MODE" screen.
3. Touch either "ALL SIGNALS" or "SELECTION FROM MENU" on the "SELECT MONITOR ITEM" screen.

All signals	Monitors all the signals.
Selection from menu	Selects and monitors individual signal.

4. Touch "START".
5. When "SELECTION FROM MENU" is selected, touch individual items to be monitored. When "ALL SIGNALS" is selected, all the items will be monitored.
6. Touch "RECORD" while monitoring, then the status of the monitored item can be recorded. To stop recording, touch "STOP".

### Display Item List

Monitor item	Contents
IGN ON SW "ON/OFF"	Displays "IGN position (ON)/OFF, ACC position (OFF)" judged from the ignition switch signal.
ACC ON SW "ON/OFF"	Displays "ACC (ON)/OFF, Ignition OFF (OFF)" status judged from ignition switch signal.
HI BEAM SW "ON/OFF"	Displays status (high beam switch: ON/Others: OFF) of high beam switch judged from lighting switch signal.
HEAD LAMP SW 1 "ON/OFF"	Displays status (headlamp switch 1: ON/Others: OFF) of headlamp switch 2 judged from lighting switch signal.
HEAD LAMP SW 2 "ON/OFF"	Displays status (headlamp switch 2: ON/Others: OFF) of headlamp switch 2 judged from lighting switch signal.
LIGHT SW 1ST "ON/OFF"	Displays status (lighting switch 1st position: ON/Others: OFF) of lighting switch judged from lighting switch signal.

## HEADLAMP (FOR USA)

Monitor item	Contents
AUTO LIGHT SW "ON/OFF"	Displays status of the lighting switch as judged from the lighting switch signal. (AUTO position: ON/Other than AUTO position: OFF)
PASSING SW "ON/OFF"	Displays status (flash-to-pass switch: ON/Others: OFF) of flash-to-pass switch judged from lighting switch signal.
FR FOG SW "ON/OFF"	Displays status (front fog lamp switch: ON/Others: OFF) of front fog lamp switch judged from lighting switch signal.
DOOR SW-DR "ON/OFF"	Displays status of the driver door as judged from the driver door switch signal. (Door is open: ON/Door is closed: OFF)
DOOR SW-AS "ON/OFF"	Displays status of the passenger door as judged from the passenger door switch signal. (Door is open: ON/Door is closed: OFF)
DOOR SW-RR "ON/OFF"	Displays status of the rear door as judged from the rear door switch (RH) signal. (Door is open: ON/Door is closed: OFF)
DOOR SW-RL "ON/OFF"	Displays status of the rear door as judged from the rear door switch (LH) signal. (Door is open: ON/Door is closed: OFF)
BACK DOOR SW "ON/OFF"	Not used.
TURN SIGNAL R "ON/OFF"	Displays status (Turn right: ON/Others: OFF) as judged from lighting switch signal.
TURN SIGNAL L "ON/OFF"	Displays status (Turn left: ON/Others: OFF) as judged from lighting switch signal.
CARGO LAMP SW "ON/OFF"	Displays status of cargo lamp switch.
OPTICAL SENSOR [0 - 5V]	Displays "ambient light (close to 5V when dark/close to 0V when light)" judged from optical sensor signal.

### ACTIVE TEST

#### Operation Procedure

1. Touch "HEAD LAMP" on "SELECT TEST ITEM" screen.
2. Touch "ACTIVE TEST" on "SELECT DIAG MODE" screen.
3. Touch item to be tested and check operation of the selected item.
4. During the operation check, touching "BACK" deactivates the operation.

#### Display Item List

Test item	Description
TAIL LAMP	Allows tail lamp relay to operate by switching ON-OFF.
HEAD LAMP	Allows headlamp relay (HI, LO) to operate by switching ON-OFF.
FR FOG LAMP	Allows fog lamp relay to operate by switching ON-OFF.
CARGO LAMP	Allows cargo lamp to operate by switching ON-OFF.
CORNERING LAMP	Not used.

### SELF-DIAGNOSTIC RESULTS

#### Operation Procedure

1. Touch "BCM" on "SELECT TEST ITEM" screen.
2. Touch "SELF-DIAG RESULTS" on "SELECT DIAG MODE" screen.
3. Self-diagnostic results are displayed.

#### Display Item List

Monitored item	CONSULT-II display	Description
CAN communication	CAN communication [U1000]	Malfunction is detected in CAN communication.
CAN communication system	CAN communication system 1 to 6 [U1000]	Malfunction is detected in CAN system.

# HEADLAMP (FOR USA)

EKS00A95

## CONSULT-II Function (IPDM E/R)

CONSULT-II can display each diagnostic item using the diagnostic test modes shown following.

IPDM E/R diagnostic mode	Description
SELF-DIAG RESULTS	Displays IPDM E/R self-diagnosis results.
DATA MONITOR	Displays IPDM E/R input/output data in real time.
CAN DIAG SUPPORT MNTR	The result of transmit/receive diagnosis of CAN communication can be read.
ACTIVE TEST	Operation of electrical loads can be checked by sending drive signal to them.

## CONSULT-II OPERATION

### CAUTION:

If CONSULT-II is used with no connection of CONSULT-II CONVERTER, malfunctions might be detected in self-diagnosis depending on control unit which carries out CAN communication.

1. With the ignition switch OFF, connect CONSULT-II and CONSULT-II CONVERTER to the data link connector, then turn the ignition switch ON.

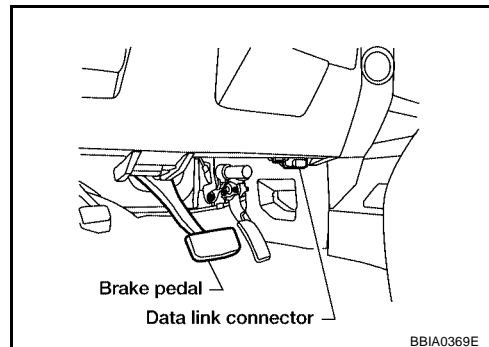

2. Touch "START (NISSAN BASED VHCL)".

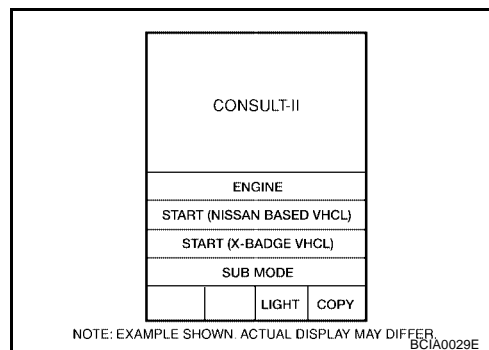

3. Touch "IPDM E/R" on "SELECT SYSTEM" screen. If "IPDM E/R" is not displayed, refer to [GI-38, "CONSULT-II Data Link Connector \(DLC\) Circuit"](#).

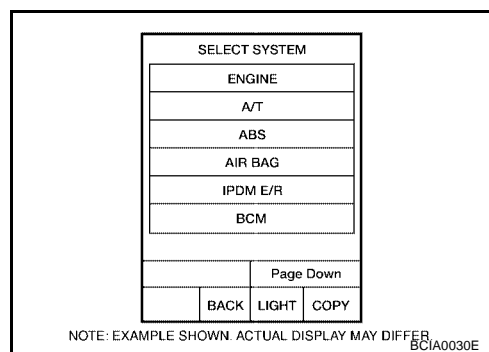

# HEADLAMP (FOR USA)

- Select the desired part to be diagnosed on the "SELECT DIAG MODE" screen.

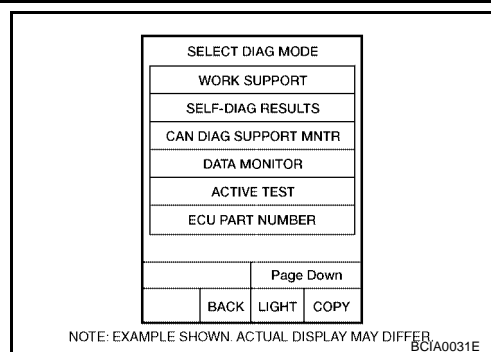

## DATA MONITOR

### Operation Procedure

- Touch "DATA MONITOR" on "SELECT DIAG MODE" screen.
- Touch "ALL SIGNALS", "MAIN SIGNALS" or "SELECTION FROM MENU" on the "SELECT MONITOR ITEM" screen.

ALL SIGNALS	All items will be monitored.
MAIN SIGNALS	Monitor the predetermined item.
SELECTION FROM MENU	Select any item for monitoring.

- Touch "START".
- Touch the required monitoring item on "SELECT ITEM MENU". In "ALL SIGNALS", all items are monitored. In "MAIN SIGNALS", predetermined items are monitored.
- Touch "RECORD" while monitoring to record the status of the item being monitored. To stop recording, touch "STOP".

### All Items, Main Items, Select Item Menu

Item name	CONSULT-II screen display	Display or unit	Monitor item selection			Description
			ALL SIGNALS	MAIN SIGNALS	SELECTION FROM MENU	
Parking, license plate and tail lamps request	TAIL&CLR REQ	ON/OFF	×	×	×	Signal status input from BCM
Headlamp low beam request	HL LO REQ	ON/OFF	×	×	×	Signal status input from BCM
Headlamp high beam request	HL HI REQ	ON/OFF	×	×	×	Signal status input from BCM
Daytime lights request	DTRL REQ	ON/OFF	×	–	×	Signal status input from BCM
Front fog lamps request	FR FOG REQ	ON/OFF	×	×	×	Signal status input from BCM

#### NOTE:

Perform monitoring of IPDM E/R data with the ignition switch ON. When the ignition switch is at ACC, the display may not be correct.

## ACTIVE TEST

### Operation Procedure

- Touch "ACTIVE TEST" on "SELECT DIAG MODE" screen.
- Touch "EXTERNAL LAMPS" on "SELECT TEST ITEM" screen.
- Touch item to be tested, and check operation.
- Touch "START".
- Touch "STOP" while testing to stop the operation.

# HEADLAMP (FOR USA)

Test item	CONSULT-II screen display	Description
Tail lamp relay output	TAIL LAMP	Allows tail lamp relay to operate by switching operation ON-OFF at your option.
Headlamp relay (HI, LO) output	LAMPS	Allows headlamp relay (HI, LO) to operate by switching operation (OFF, HI, LO) at your option (Head lamp high beam repeats ON-OFF every 1 second).
Front fog lamp relay (FOG) output		Allows fog lamp relay (FOG) to operate by switching operation ON-OFF at your option.
Cornering lamp relay (RH, LH) output	CORNERING LAMP	Allows cornering lamp relay (RH, LH) to operate by switching operation ON-OFF at your option.

## Headlamp HI Does Not Illuminate (Both Sides)

EKS00A96

### 1. CHECK COMBINATION SWITCH INPUT SIGNAL

Select "BCM" on CONSULT-II. With "HEAD LAMP" data monitor, make sure "HI BEAM SW" turns ON-OFF linked with operation of lighting switch.

**When lighting switch is in HIGH position : HI BEAM SW ON**

OK or NG

OK >> GO TO 2.

NG >> Check lighting switch. Refer to [LT-95, "Combination Switch Inspection"](#).

DATA MONITOR	
MONITOR	
HI BEAM SW	ON

SKIA4193E

### 2. HEADLAMP ACTIVE TEST

1. Select "IPDM E/R" on CONSULT-II, and select "ACTIVE TEST" on "SELECT DIAG MODE" screen.
2. Select "EXTERNAL LAMPS" on "SELECT TEST ITEM" screen.
3. Touch "HI" on "ACTIVE TEST" screen.
4. Make sure headlamp high beam operates.

**Headlamp high beam should operate.**

OK or NG

OK >> GO TO 3.

NG >> GO TO 4.

ACTIVE TEST			
EXTERNAL LAMPS		OFF	
		TAIL	
LO		HI	
FOG			
MODE	BACK	LIGHT	COPY

WKIA1438E

### 3. CHECK IPDM E/R

1. Select "IPDM E/R" on CONSULT-II, and select "DATA MONITOR" on "SELECT DIAG MODE" screen.
2. Make sure "HL LO REQ" and "HL HI REQ" turns ON when lighting switch is in HIGH position.

**When lighting switch is in HIGH position : HL LO REQ ON  
: HL HI REQ ON**

OK or NG

OK >> Replace IPDM E/R. Refer to [PG-28, "Removal and Installation of IPDM E/R"](#).

NG >> Replace BCM. Refer to [BCS-19, "Removal and Installation of BCM"](#).

DATA MONITOR			
MONITOR			
HL LO REQ	ON		
HL HI REQ	ON		
Page Down			
RECORD			
MODE	BACK	LIGHT	COPY

SKIA5775E

# HEADLAMP (FOR USA)

## 4. CHECK HEADLAMP INPUT SIGNAL

1. Turn ignition switch OFF.
2. Disconnect front combination lamp RH and LH connector.
3. Turn ignition switch ON.
4. Select "IPDM E/R" on CONSULT-II, and select "ACTIVE TEST" on "SELECT DIAG MODE" screen.
5. Select "EXTERNAL LAMPS" on "SELECT TEST ITEM" screen.
6. Touch "HI" on "ACTIVE TEST" screen.
7. When headlamp high beam is operating, check voltage between front combination lamp RH and LH harness connector and ground.

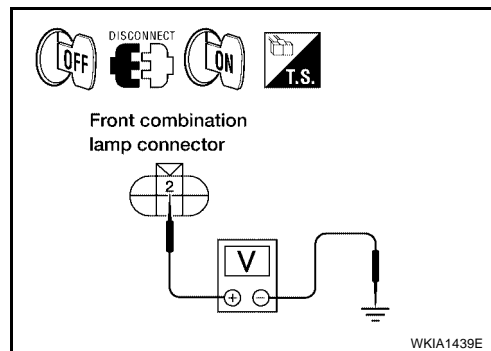

Terminals			Voltage
(+)		(-)	
Connector	Terminal (Wire color)		
RH	E107	2 (L/W)	Ground
LH	E11	2 (G)	
			Battery voltage

OK or NG

- OK >> GO TO 6.  
 NG >> GO TO 5.

## 5. CHECK HEADLAMP CIRCUIT

1. Turn ignition switch OFF.
2. Disconnect IPDM E/R connector.
3. Check continuity between IPDM E/R harness connector E123 terminal 56 (L/W) and front combination lamp RH harness connector E107 terminal 2 (L/W).

**56 (L/W) - 2 (L/W) : Continuity should exist.**

4. Check continuity between IPDM E/R harness connector E123 terminal 55 (G) and front combination lamp LH harness connector E11 terminal 2 (G).

**55 (G) - 2 (G) : Continuity should exist.**

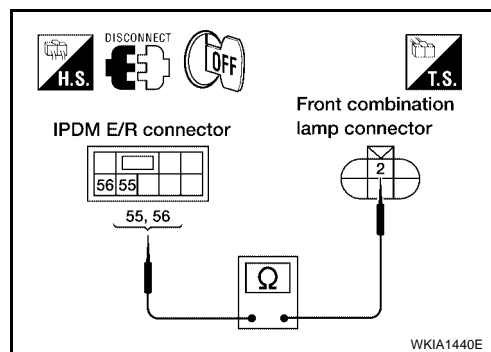

OK or NG

- OK >> Replace IPDM E/R. Refer to [PG-28, "Removal and Installation of IPDM E/R"](#) .  
 NG >> Repair harness or connector.

## 6. CHECK HEADLAMP GROUND

1. Check continuity between front combination lamp RH harness connector E107 terminal 3 (B) and ground.

**3 (B) - Ground : Continuity should exist.**

2. Check continuity between front combination lamp LH harness connector E11 terminal 3 (B) and ground.

**3 (B) - Ground : Continuity should exist.**

OK or NG

- OK >> Check front combination lamp connector for damage or poor connection. Repair as necessary.  
 NG >> Repair harness or connector.

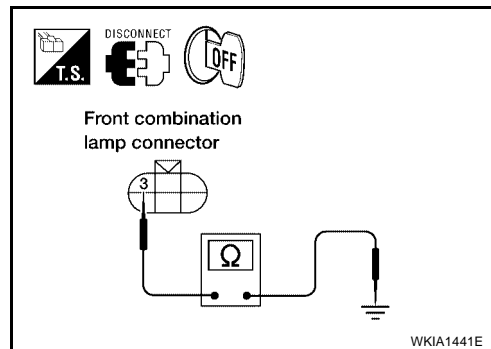

# HEADLAMP (FOR USA)

EKS00A97

## Headlamp HI Does Not Illuminate (One Side)

### 1. BULB INSPECTION

Inspect inoperative headlamp bulb.

OK or NG

OK >> GO TO 2.

NG >> Replace headlamp bulb. Refer to [LT-30, "HEADLAMP \(INNER SIDE\), FOR HIGH BEAM"](#) .

### 2. CHECK POWER TO HEADLAMP

1. Disconnect inoperative headlamp connector.
2. Turn the high beam headlamps ON.
3. Check voltage between inoperative headlamp terminal and ground.

Terminals			Voltage (Approx.)
(+)		(-)	
Connector	Terminal (Wire color)		
RH	E107	2 (L/W)	Ground
LH	E11	2 (G)	
			Battery voltage

OK or NG

OK >> GO TO 3.

NG >> GO TO 4.

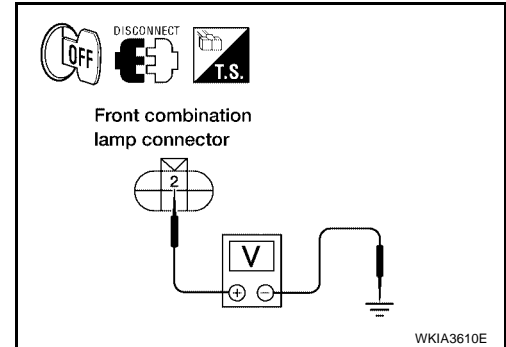

### 3. CHECK HEADLAMP GROUND

1. Turn the high beam headlamps OFF.
2. Check continuity between inoperative headlamp connector and ground.

Terminals			Continuity
Connector	Terminal (Wire color)		
RH	E107	3 (B)	Ground
LH	E11	3 (B)	
			Yes

OK or NG

OK >> Check headlamp connector for damage or poor connection. Repair as necessary.

NG >> Repair open circuit in harness between inoperative headlamp and ground.

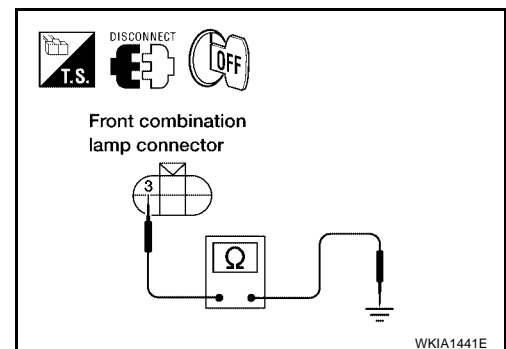



# HEADLAMP (FOR USA)

## 4. INSPECTION BETWEEN IPDM E/R AND HEADLAMPS

1. Disconnect IPDM E/R connector and inoperative headlamp connector.
2. Check continuity between harness connector terminals of IPDM E/R and harness connector terminals of inoperative headlamp.

Terminals					Continuity
IPDM E/R		Headlamp			
Connector	Terminal (wire color)	Connector	Terminal (wire color)		
E123	56 (L/W)	RH	E107	2 (L/W)	Yes
	55 (G)	LH	E11	2 (G)	

OK or NG

OK >> Replace IPDM E/R. Refer to [PG-28, "Removal and Installation of IPDM E/R"](#).

NG >> Check for short and open circuits in harness between IPDM E/R and headlamps. Repair as necessary.

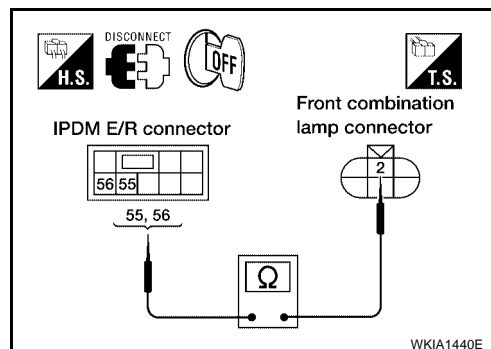

## High Beam Indicator Lamp Does Not Illuminate

EKS00A98

### 1. BULB INSPECTION

Inspect CAN communication system. Refer to [LAN-7, "CAN COMMUNICATION"](#).

OK or NG

OK >> Replace combination meter. Refer to [IP-13, "COMBINATION METER"](#).

NG >> Repair as necessary.

## Headlamp LO Does Not Illuminate (Both Sides)

EKS00A99

### 1. CHECK COMBINATION SWITCH INPUT SIGNAL

Select "BCM" on CONSULT-II. With "HEAD LAMP" data monitor, make sure "HEAD LAMP SW 1" and "HEAD LAMP SW 2" turns ON-OFF linked with operation of lighting switch.

**When lighting switch is in 2ND position :**  
**HEAD LAMP SW 1 ON**  
**HEAD LAMP SW 2 ON**

OK or NG

OK >> GO TO 2.

NG >> Check lighting switch. Refer to [LT-95, "Combination Switch Inspection"](#).

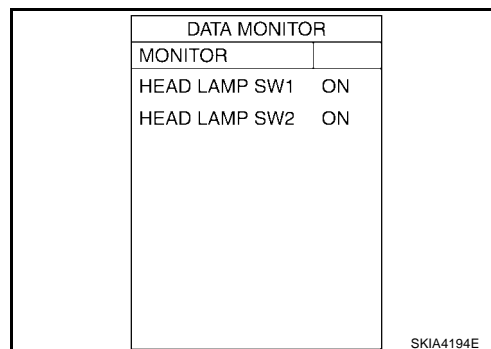

## 2. HEADLAMP ACTIVE TEST

1. Select "IPDM E/R" on CONSULT-II, and select "ACTIVE TEST" on "SELECT DIAG MODE" screen.
2. Select "EXTERNAL LAMPS" on "SELECT TEST ITEM" screen.
3. Touch "LO" on "ACTIVE TEST" screen.
4. Make sure headlamp low beam operates.

**Headlamp low beam should operate.**

OK or NG

OK >> GO TO 3.

NG >> GO TO 4.

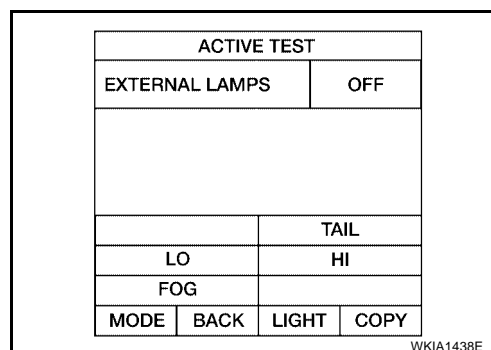

# HEADLAMP (FOR USA)

## 3. CHECK IPDM E/R

1. Select "IPDM E/R" on CONSULT-II, and select "DATA MONITOR" on "SELECT DIAG MODE" screen.
2. Make sure "HL LO REQ" turns ON when lighting switch is in 2ND position.

**When lighting switch is in 2ND position : HL LO REQ ON**

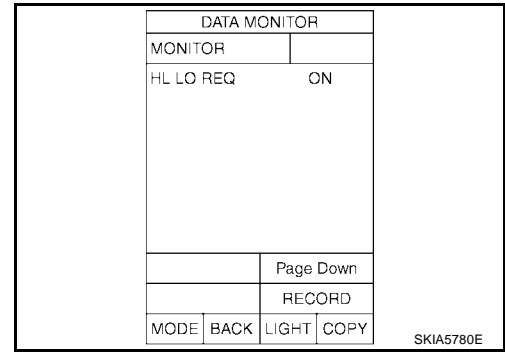

OK or NG

- OK >> Replace IPDM E/R. Refer to [PG-28, "Removal and Installation of IPDM E/R"](#).
- NG >> Replace BCM. Refer to [BCS-19, "Removal and Installation of BCM"](#).

## 4. CHECK HEADLAMP INPUT SIGNAL

1. Turn ignition switch OFF.
2. Disconnect front combination lamp RH and LH connectors.
3. Turn ignition switch ON.
4. Select "IPDM E/R" on CONSULT-II, and select "ACTIVE TEST" on "SELECT DIAG MODE" screen.
5. Select "EXTERNAL LAMPS" on "SELECT TEST ITEM" screen.
6. Touch "LO" on "ACTIVE TEST" screen.
7. When headlamp low beam is operating, check voltage between front combination lamp RH and LH harness connector and ground.

Terminals			Voltage
(+)		(-)	
Connector	Terminal (Wire color)		
RH	E107	1 (R/Y)	Ground
LH	E11	1 (L)	
			Battery voltage

OK or NG

- OK >> GO TO 6.
- NG >> GO TO 5.

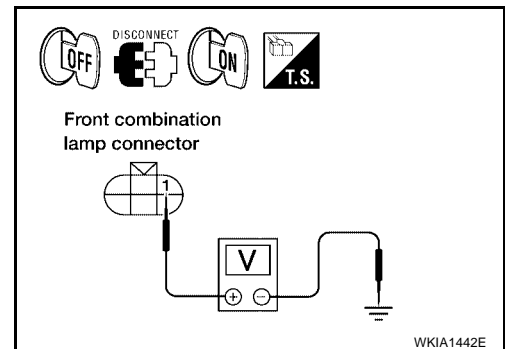

## 5. CHECK HEADLAMP CIRCUIT

1. Turn ignition switch OFF.
2. Disconnect IPDM E/R connector.
3. Check continuity between IPDM E/R harness connector E123 terminal 54 (R/Y) and front combination lamp RH harness connector E107 terminal 1 (R/Y).

**54 (R/Y) - 1 (R/Y) : Continuity should exist.**

4. Check continuity between IPDM E/R harness connector E123 terminal 52 (L) and front combination lamp LH harness connector E11 terminal 1 (L).

**52 (L) - 1 (L) : Continuity should exist.**

OK or NG

- OK >> Replace IPDM E/R. Refer to [PG-28, "Removal and Installation of IPDM E/R"](#).
- NG >> Repair harness or connector.

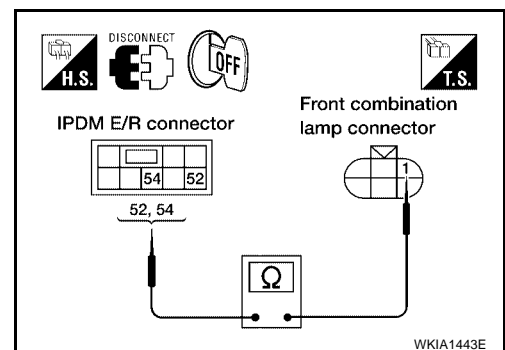

# HEADLAMP (FOR USA)

## 6. CHECK HEADLAMP GROUND

1. Turn ignition switch OFF.
2. Check continuity between front combination lamp RH harness connector E107 terminal 4 (B) and ground.

**4 (B) - Ground : Continuity should exist.**

3. Check continuity between front combination lamp LH harness connector E11 terminal 4 (B) and ground.

**4 (B) - Ground : Continuity should exist.**

OK or NG

OK >> Check front combination lamp connector for damage or poor connection. Repair as necessary.

NG >> Repair harness or connector.

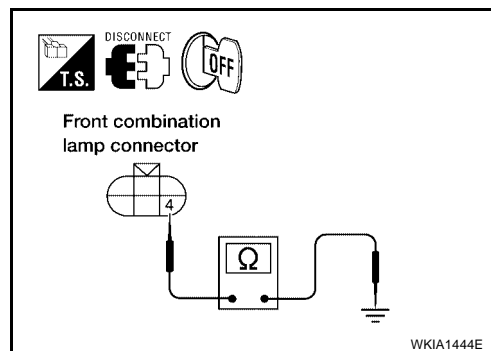

## Headlamp LO Does Not Illuminate (One Side)

EKS00A9A

### 1. BULB INSPECTION

Inspect inoperative headlamp bulb.

OK or NG

OK >> GO TO 2.

NG >> Replace headlamp bulb. Refer to [LT-30, "HEADLAMP \(OUTER SIDE\), FOR LOW BEAM"](#).

### 2. CHECK POWER TO HEADLAMP

1. Disconnect inoperative headlamp connector.
2. Turn the low beam headlamps ON.
3. Check voltage between inoperative headlamp connector terminal and ground.

Terminals			Voltage (Approx.)
(+)		(-)	
Connector	Terminal		
RH	E107	1 (R/Y)	Ground
LH	E11	1 (L)	
			Battery voltage

OK or NG

OK >> GO TO 3.

NG >> GO TO 4.

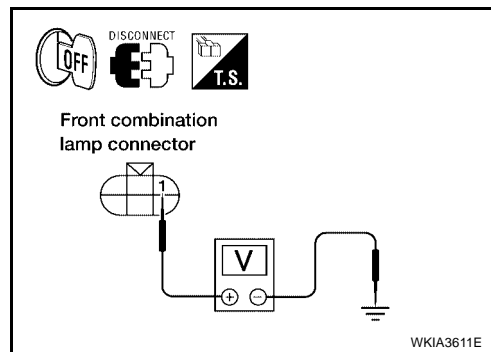

### 3. CHECK HEADLAMP GROUND

1. Turn the low beam headlamps OFF.
2. Check continuity between inoperative headlamp connector terminal and ground.

Terminals			Continuity
Connector	Terminal (Wire color)		
RH	E107	4 (B)	Ground
LH	E11	4 (B)	
			Yes

OK or NG

OK >> Check headlamp and IPDM E/R connector. Repair as necessary.

NG >> Repair open circuit in harness between inoperative headlamp and ground.

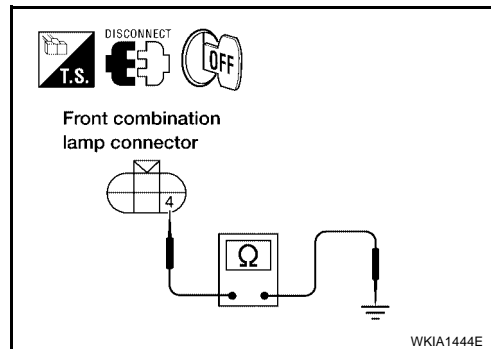

# HEADLAMP (FOR USA)

## 4. INSPECTION BETWEEN IPDM E/R AND HEADLAMPS

1. Disconnect IPDM E/R connector.
2. Check continuity between harness connector terminals of IPDM E/R and harness connector terminals of inoperative headlamp.

Terminals					Continuity
IPDM E/R		Front combination lamp			
Connector	Terminal (Wire color)	Connector	Terminal (Wire color)		
E123	54 (R/Y)	RH	E107	1 (R/Y)	Yes
	52 (L)	LH	E11	1 (L)	

OK or NG

OK >> Replace IPDM E/R. Refer to [PG-28, "Removal and Installation of IPDM E/R"](#).

NG >> Check for short circuits and open circuits in harness between IPDM E/R and headlamps. Repair as necessary.

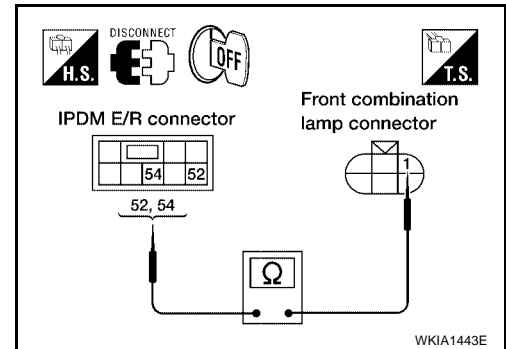

## Headlamps Do Not Turn OFF

EKS00A9B

### 1. CHECK COMBINATION SWITCH INPUT SIGNAL

Select "BCM" on CONSULT-II. With "HEAD LAMP" data monitor, make sure "HEAD LAMP SW 1" and "HEAD LAMP SW 2" turns ON-OFF linked with operation of lighting switch.

**When lighting switch is in OFF position** : HEAD LAMP SW 1 OFF  
: HEAD LAMP SW 2 OFF

OK or NG

OK >> Replace IPDM E/R. Refer to [PG-28, "Removal and Installation of IPDM E/R"](#).

NG >> GO TO 2.

DATA MONITOR	
MONITOR	
HEAD LAMP SW 1	OFF
HEAD LAMP SW 2	OFF

SKIA5200E

### 2. CHECK LIGHTING SWITCH

Check lighting switch. Refer to [LT-95, "Combination Switch Inspection"](#).

OK or NG

OK >> GO TO 3.

NG >> Replace switch. Refer to [LT-97, "Removal and Installation"](#).

### 3. CHECKING CAN COMMUNICATIONS BETWEEN BCM AND IPDM E/R

Select "BCM" on CONSULT-II and perform self-diagnosis for BCM.

Display of self-diagnosis results

NO DTC>>Replace IPDM E/R. Refer to [PG-28, "Removal and Installation of IPDM E/R"](#).

CAN COMM CIRCUIT>> Refer to [BCS-13, "CAN Communication Inspection Using CONSULT-II \(Self-Diagnosis\)"](#).

SELF-DIAG RESULTS			
DTC RESULTS		TIME	
CAN COMM CIRCUIT [U1000]		PAST	
ERASE		PRINT	
MODE	BACK	LIGHT	COPY

SKIA1039E

# HEADLAMP (FOR USA)

## Aiming Adjustment

EKS00A9C

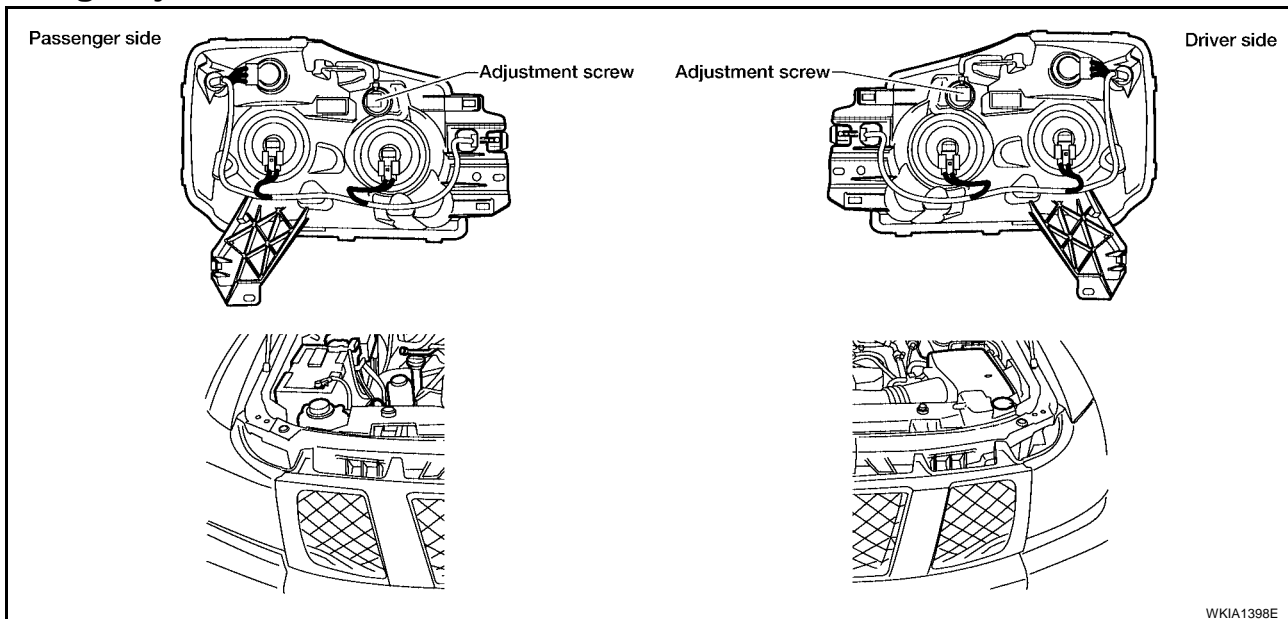

**For details, refer to the regulations in your state.**

Before performing aiming adjustment, check the following.

1. Ensure all tires are inflated to correct pressure.
2. Place vehicle and screen on level surface.
3. Ensure there is no load in vehicle other than the driver (or equivalent weight placed in driver's position). Coolant and engine oil filled to correct level, and fuel tank full.
4. Confirm spare tire, jack and tools are properly stowed.

### LOW BEAM AND HIGH BEAM

#### NOTE:

Aim each headlamp individually and ensure other headlamp beam pattern is blocked from screen.

1. Turn headlamp low beam on.
2. Use adjusting screw to perform aiming adjustment.

A  
B  
C  
D  
E  
F  
G

H  
I  
J

LT

L  
M

# HEADLAMP (FOR USA)

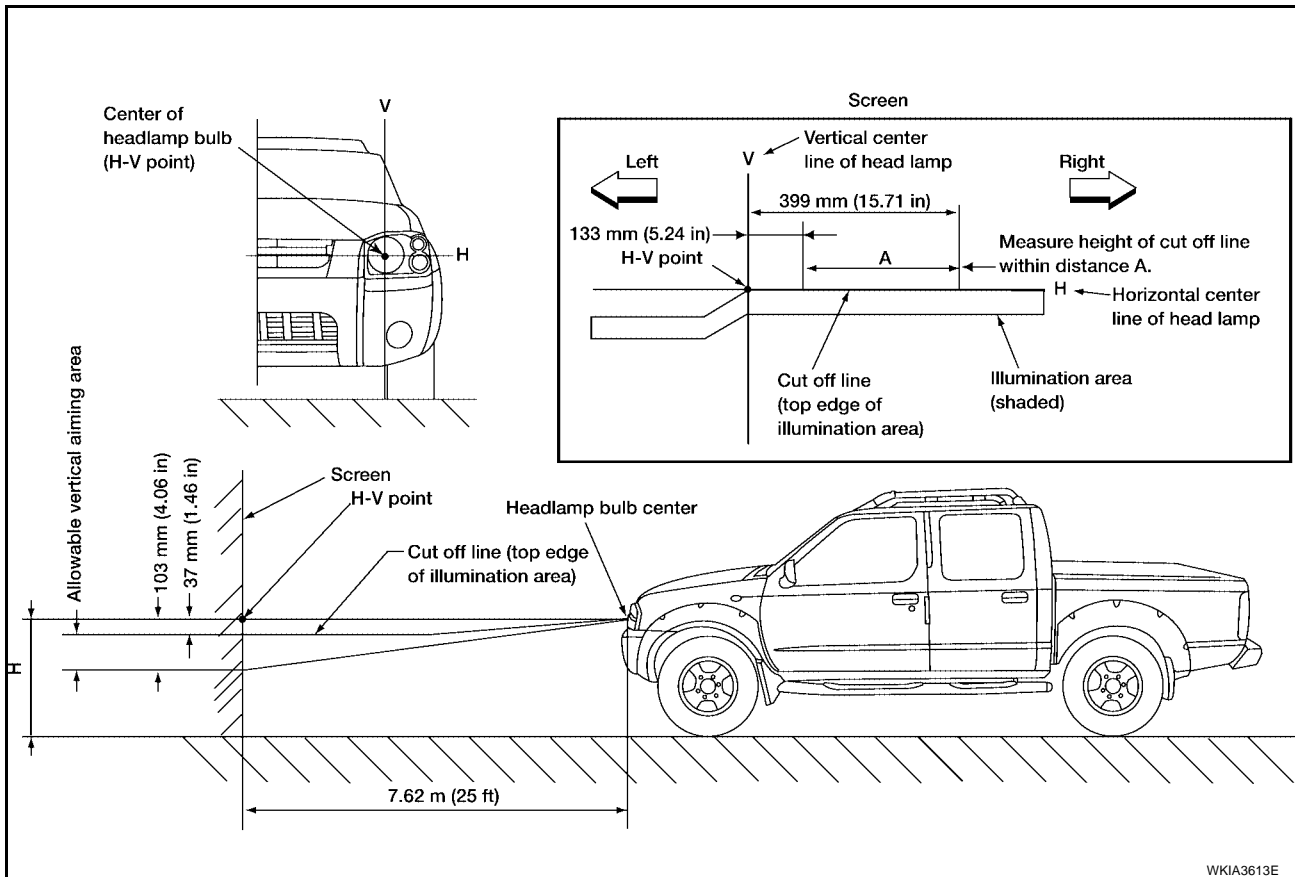

If the vehicle front body has been repaired and/or the headlamp assembly has been replaced, check aiming. Use the aiming chart shown in the figure.

- **Basic illuminating area for adjustment should be within the range shown on the aiming chart. Adjust headlamps accordingly.**

## Bulb Replacement HEADLAMP (OUTER SIDE), FOR LOW BEAM

EKS00A9D

### NOTE:

Reach through wheel opening for access.

1. Turn headlamp switch OFF.
2. Disconnect the electrical connector.
3. Turn the bulb counterclockwise to remove it.

Installation is in the reverse order of removal.

## HEADLAMP (INNER SIDE), FOR HIGH BEAM

1. Turn headlamp switch OFF.
2. Disconnect the electrical connector.
3. Turn the bulb counterclockwise to remove it.

Installation is in the reverse order of removal.

## FRONT TURN SIGNAL/PARKING LAMP

### NOTE:

Reach through wheel opening for access.

1. Turn the bulb socket counterclockwise to unlock it.
2. Pull the bulb to remove it from the socket.

Installation is in the reverse order of removal.

## FRONT SIDE MARKER LAMP

### NOTE:

Reach through wheel opening for access.

# HEADLAMP (FOR USA)

1. Turn the bulb socket counterclockwise to unlock it.
  2. Pull the bulb to remove it from the socket.
- Installation is in the reverse order of removal.

**CAUTION:**

After installing the bulb, be sure to install the bulb socket securely to ensure watertightness.

## Removal and Installation

### REMOVAL

1. Remove the grille. Refer to [EI-20, "Removal and Installation"](#).
2. Remove the front bumper filler panel.
3. Disconnect the connector.
4. Remove the 4 headlamp mounting bolts.

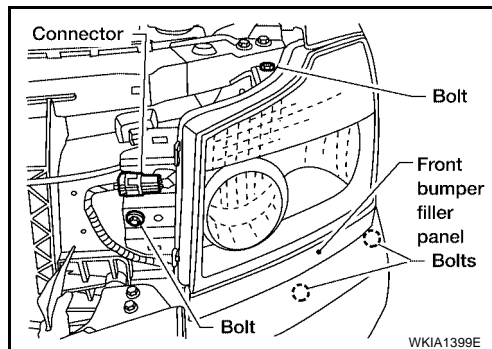

### INSTALLATION

Installation is in the reverse order of removal.

: 6.0 N-m (0.61 kg-m, 53 in-lb)

### Disassembly and Assembly

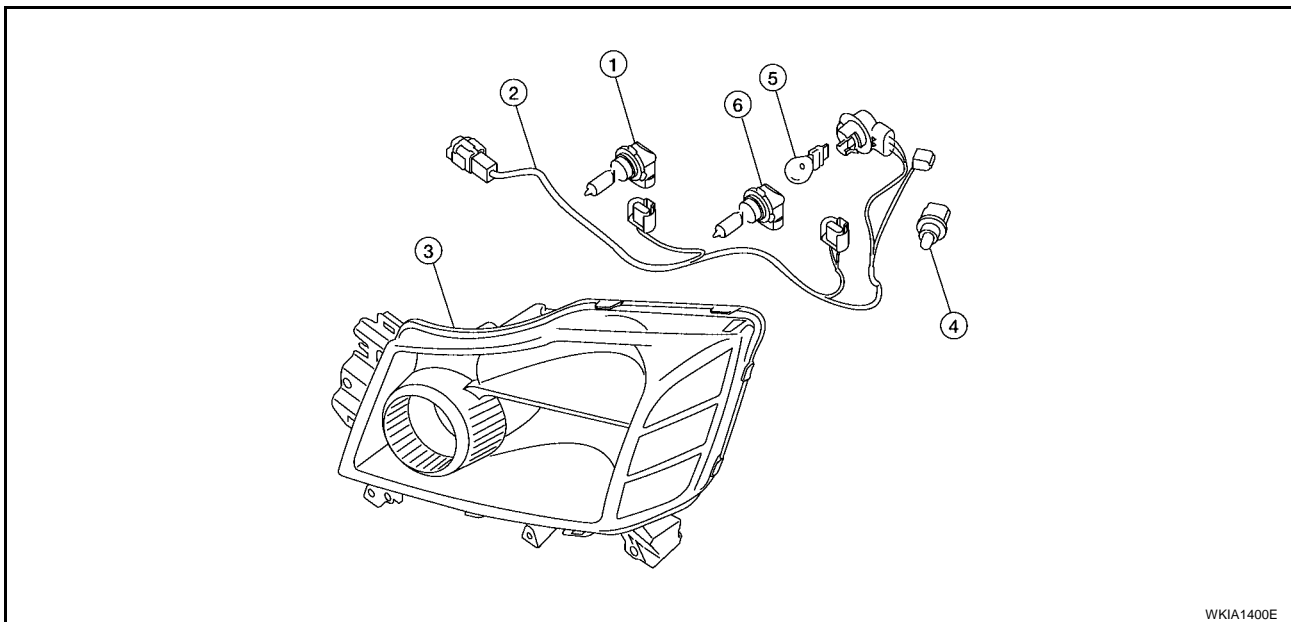

1. Headlamp bulb (High beam)
2. Wiring harness assembly
3. Headlamp assembly
4. Side marker lamp bulb
5. Parking/turn signal lamp bulb
6. Headlamp bulb (Low beam)

# HEADLAMP (FOR CANADA) - DAYTIME LIGHT SYSTEM -

## HEADLAMP (FOR CANADA) - DAYTIME LIGHT SYSTEM - Component Parts and Harness Connector Location

PF2:26010

EKS00A9G

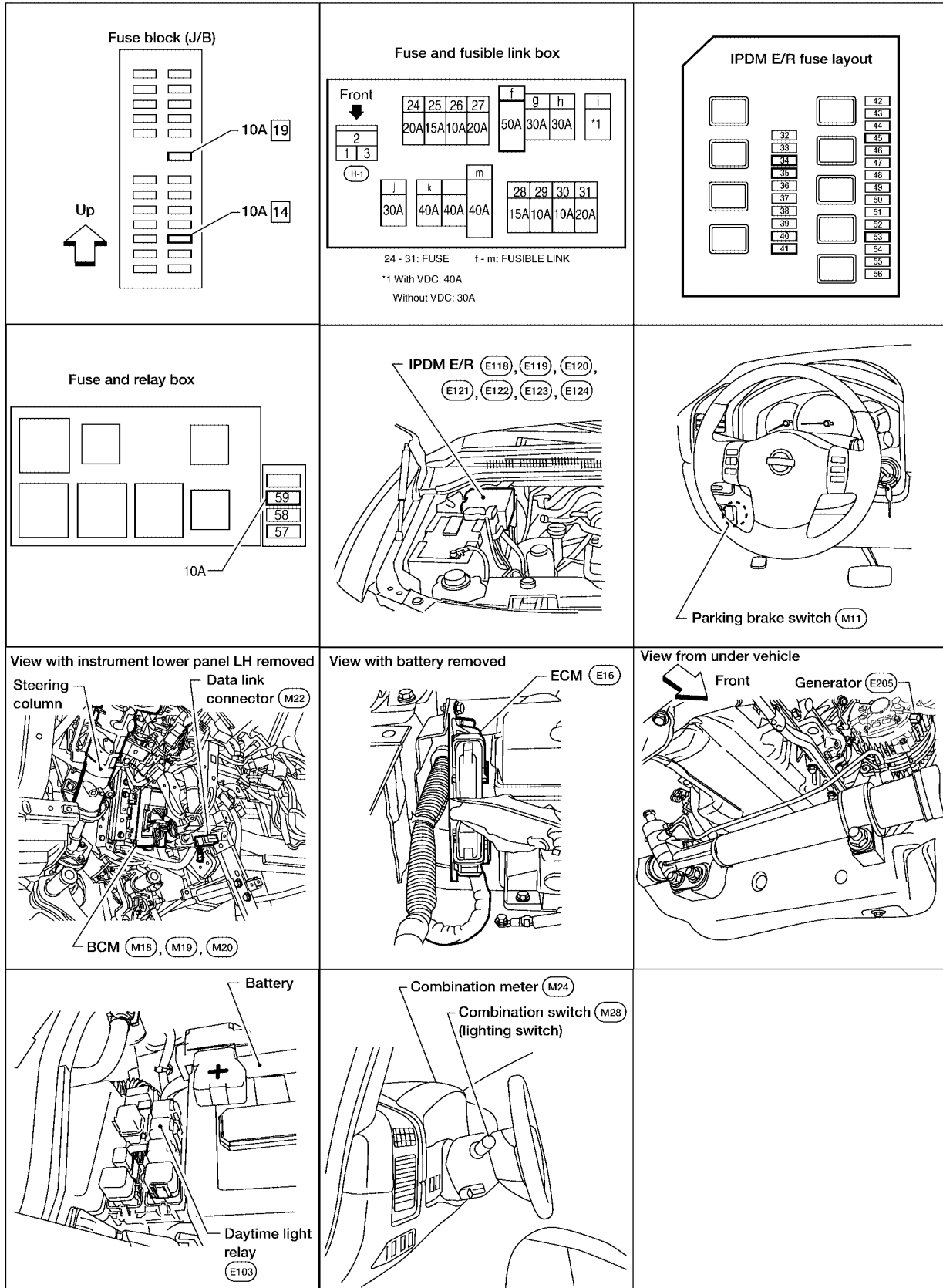

WKIA3580E



# HEADLAMP (FOR CANADA) - DAYTIME LIGHT SYSTEM -

EKS00A9H

## System Description

Daytime light system turns on daytime light lamps while driving. Daytime light lamps are not turned on if engine is activated with parking brake on. Take off parking brake to turn on daytime light lamps. The lamps turn off when lighting switch is in the 2ND position or AUTO position (Headlamp is "ON") and when lighting switch is in the PASSING position. (Daytime light lamps are not turned off only by parking brake itself.)

A parking brake signal and engine run or stop signal are sent to BCM (body control module) by CAN communication line.

## OUTLINE

Power is supplied at all times

- to ignition relay, located in the IPDM E/R (intelligent power distribution module engine room), and
- through 10A fuse [No. 19, located in the fuse block (J/B)]
- to combination meter terminal 8, and
- through 50A fusible link (letter f , located in the fuse and fusible link box)
- to BCM terminal 70, and
- through 20A fuse (No. 53, located in the IPDM E/R)
- to CPU of the IPDM E/R, and
- through 10A fuse (No. 45, located in the IPDM E/R)
- to daytime light relay terminals 2 and 5.

When the ignition switch is in ON or START position, power is supplied

- through 10A fuse [No. 14, located in the fuse block (J/B)]
- to combination meter terminal 24, and
- through 10A fuse (No. 59, located in the fuse and relay box)
- to BCM terminal 38.

Ground is supplied

- to BCM terminal 67 and
- to combination meter terminal 17
- through grounds M57, M61 and M79.

## DAYTIME LIGHT OPERATION

With the engine running, the lighting switch in the OFF or 1ST position and parking brake released, the IPDM E/R receives input requesting the daytime lights illuminate. This input is communicated across the CAN communication lines. The CPU (central processing unit) of the IPDM E/R controls the daytime light relay coil.

When energized, this relay directs power

- through daytime light relay terminal 3
- through front combination lamp LH terminal 3
- through front combination lamp LH terminal 2
- through IPDM E/R terminal 55
- through 10A fuse (No. 35, located in the IPDM E/R)
- through 10A fuse (No. 34, located in the IPDM E/R)
- through IPDM E/R terminal 56
- to front combination lamp RH terminal 2.

Ground is supplied

- to front combination lamp RH terminal 3
- through grounds E9, E15 and E24.

With power and ground supplied, the daytime lights illuminate. The high beam headlamps are now wired in series and illuminate at a reduced intensity.

## COMBINATION SWITCH READING FUNCTION

Refer to [BCS-3, "COMBINATION SWITCH READING FUNCTION"](#) .

## AUTO LIGHT OPERATION

For auto light operation, refer to [LT-47, "System Description"](#) in AUTO LIGHT SYSTEM.

A  
B  
C  
D  
E  
F  
G  
H  
I  
J  
LT  
L  
M

# HEADLAMP (FOR CANADA) - DAYTIME LIGHT SYSTEM -

---

## CAN Communication System Description

EKS00A9I

Refer to [LAN-7, "CAN COMMUNICATION"](#) .

# HEADLAMP (FOR CANADA) - DAYTIME LIGHT SYSTEM -

## Schematic

EKS00A9J

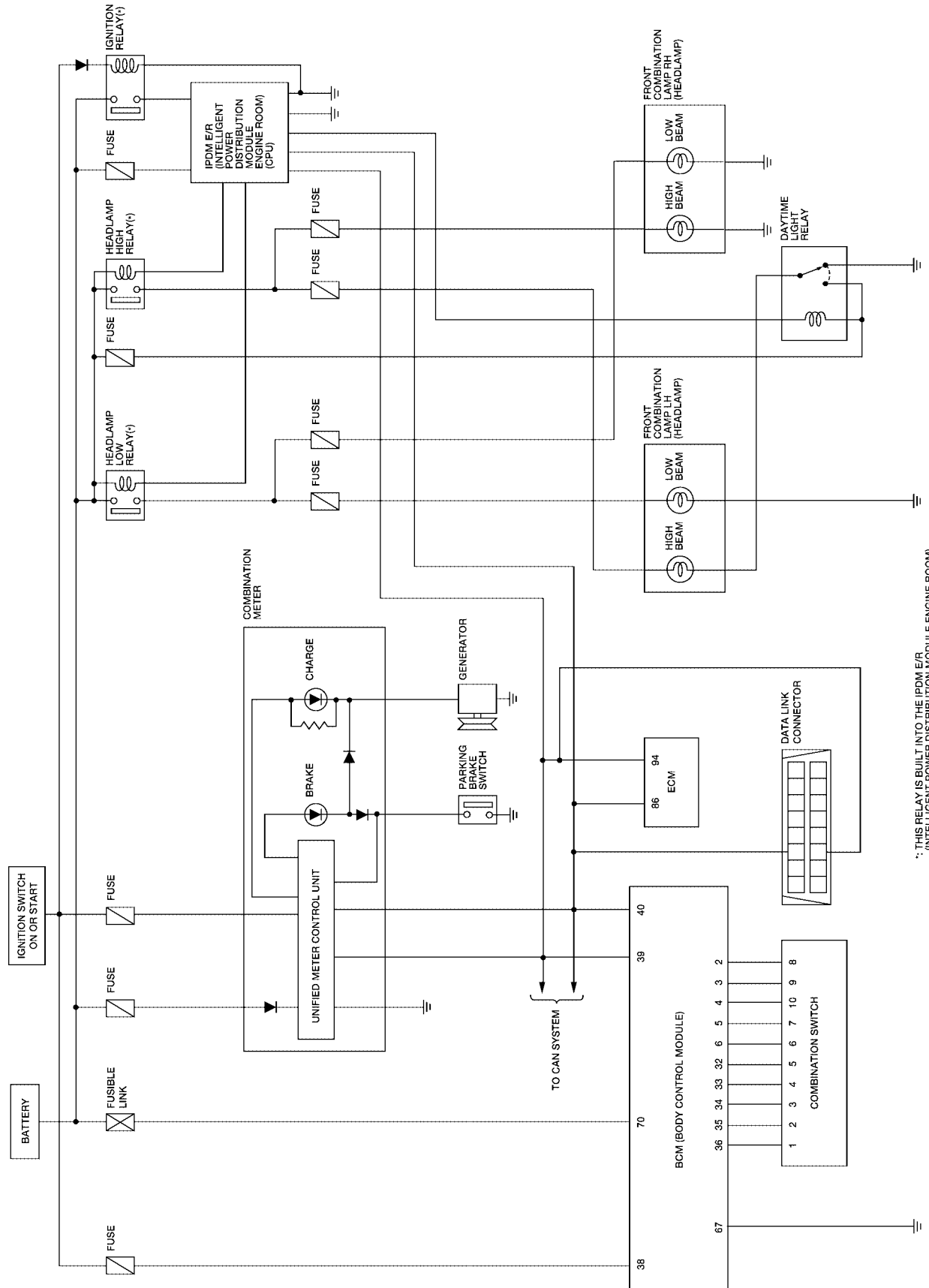

WKWA2397E

A  
B  
C  
D  
E  
F  
G  
H  
I  
J  
K  
L  
M

LT

# HEADLAMP (FOR CANADA) - DAYTIME LIGHT SYSTEM -

EKS00A9K

## Wiring Diagram — DTRL —

LT-DTRL-01

— : DATA LINE

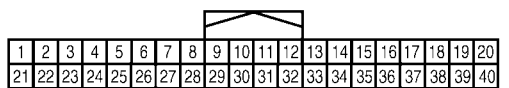
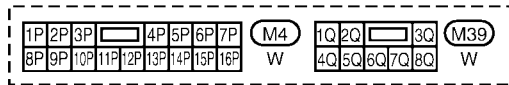
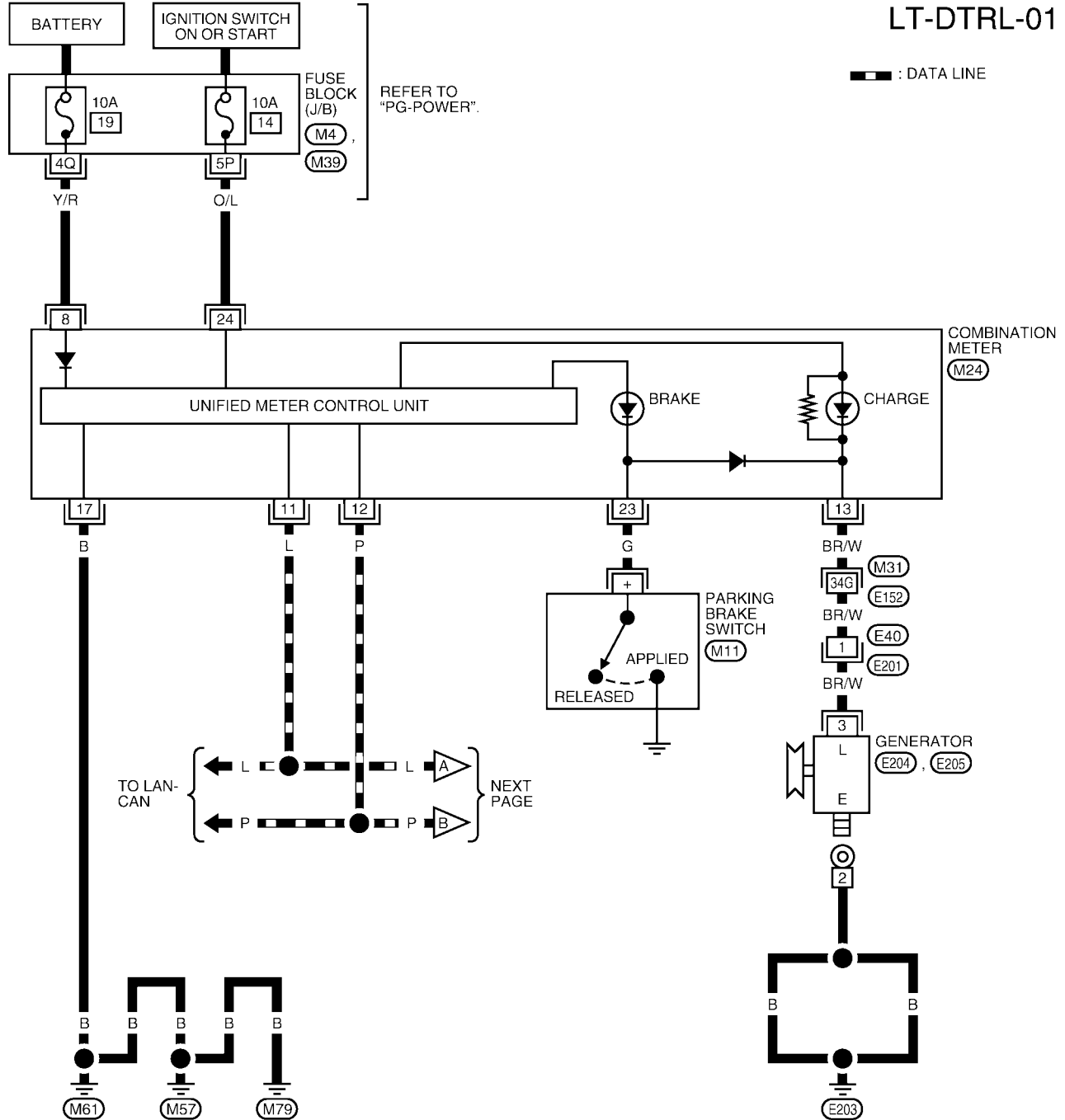

REFER TO THE FOLLOWING.  
 (M31) - SUPER MULTIPLE JUNCTION (SMJ)

WKWA2398E

# HEADLAMP (FOR CANADA) - DAYTIME LIGHT SYSTEM -

LT-DTRL-02

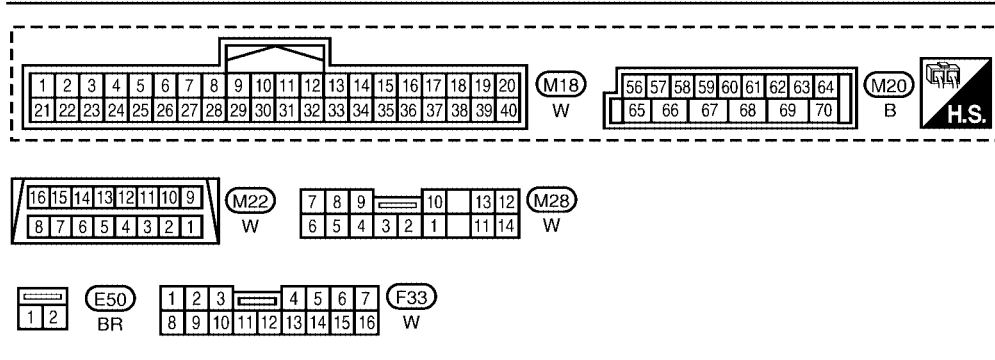
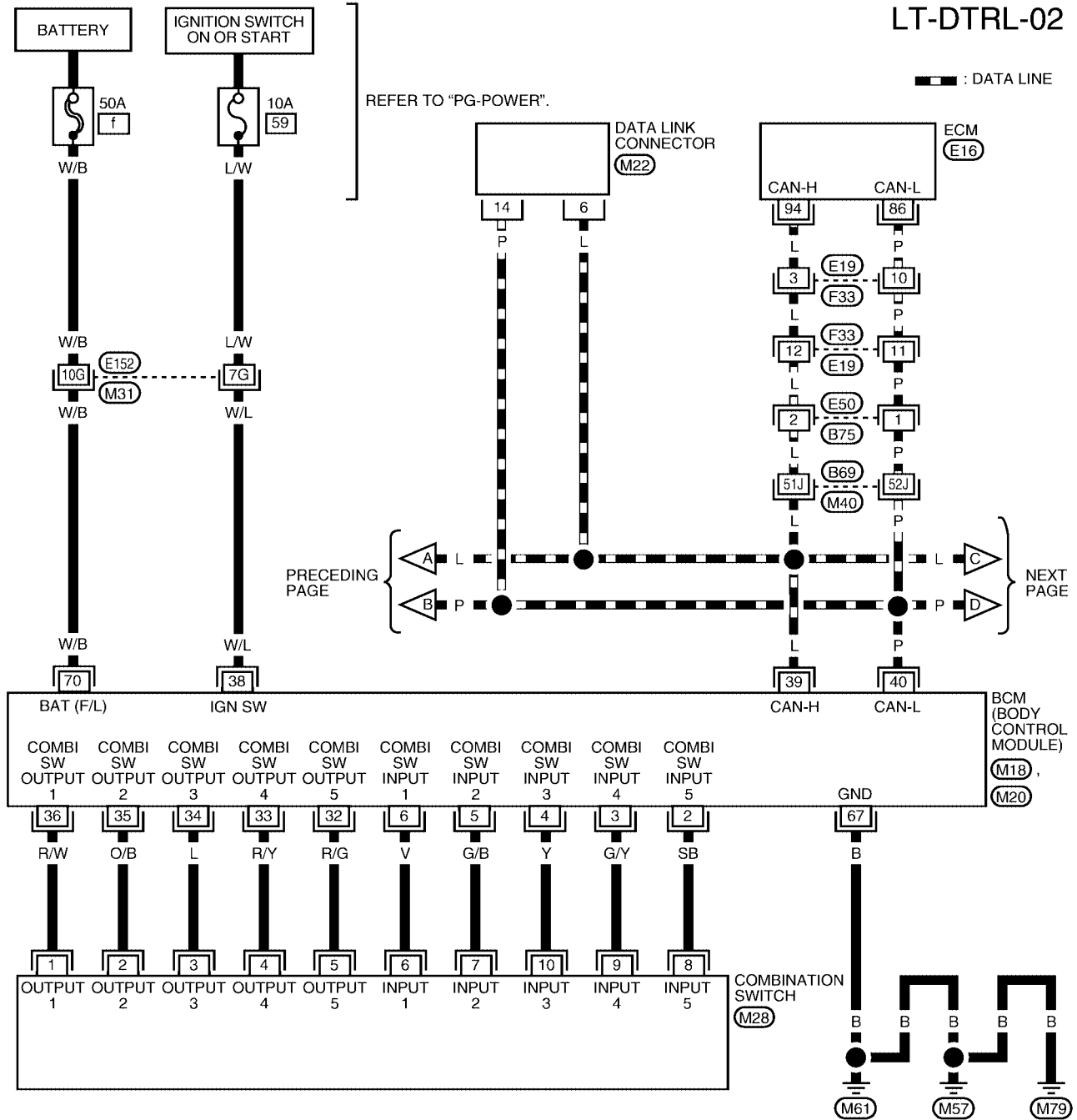

WKWA2442E

# HEADLAMP (FOR CANADA) - DAYTIME LIGHT SYSTEM -

LT-DTRL-03

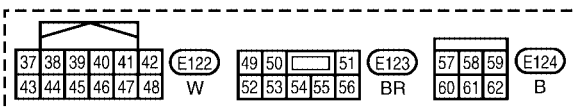
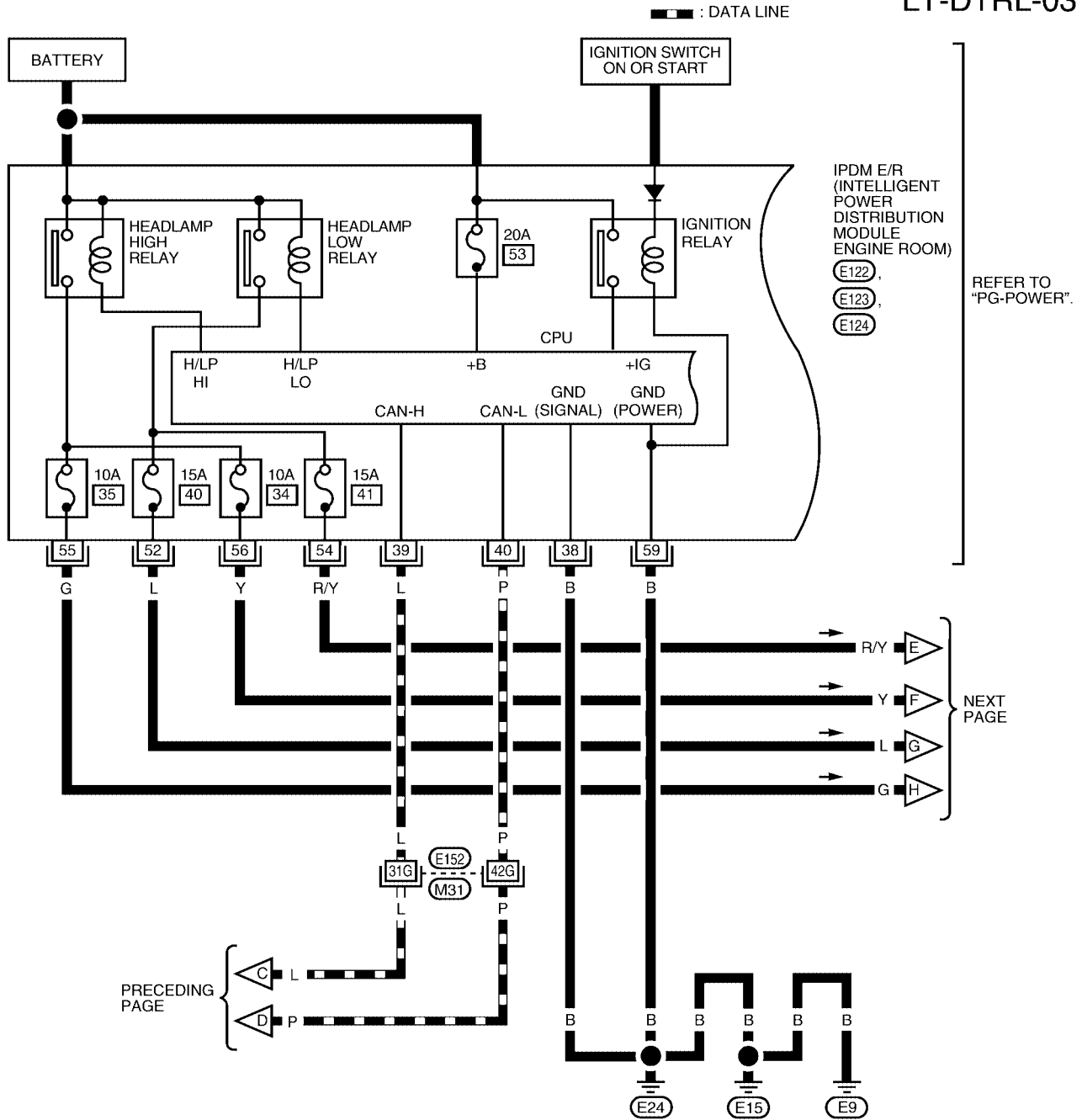

REFER TO THE FOLLOWING.  
 (M31) - SUPER MULTIPLE JUNCTION (SMJ)

WKWA2400E

# HEADLAMP (FOR CANADA) - DAYTIME LIGHT SYSTEM -

LT-DTRL-04

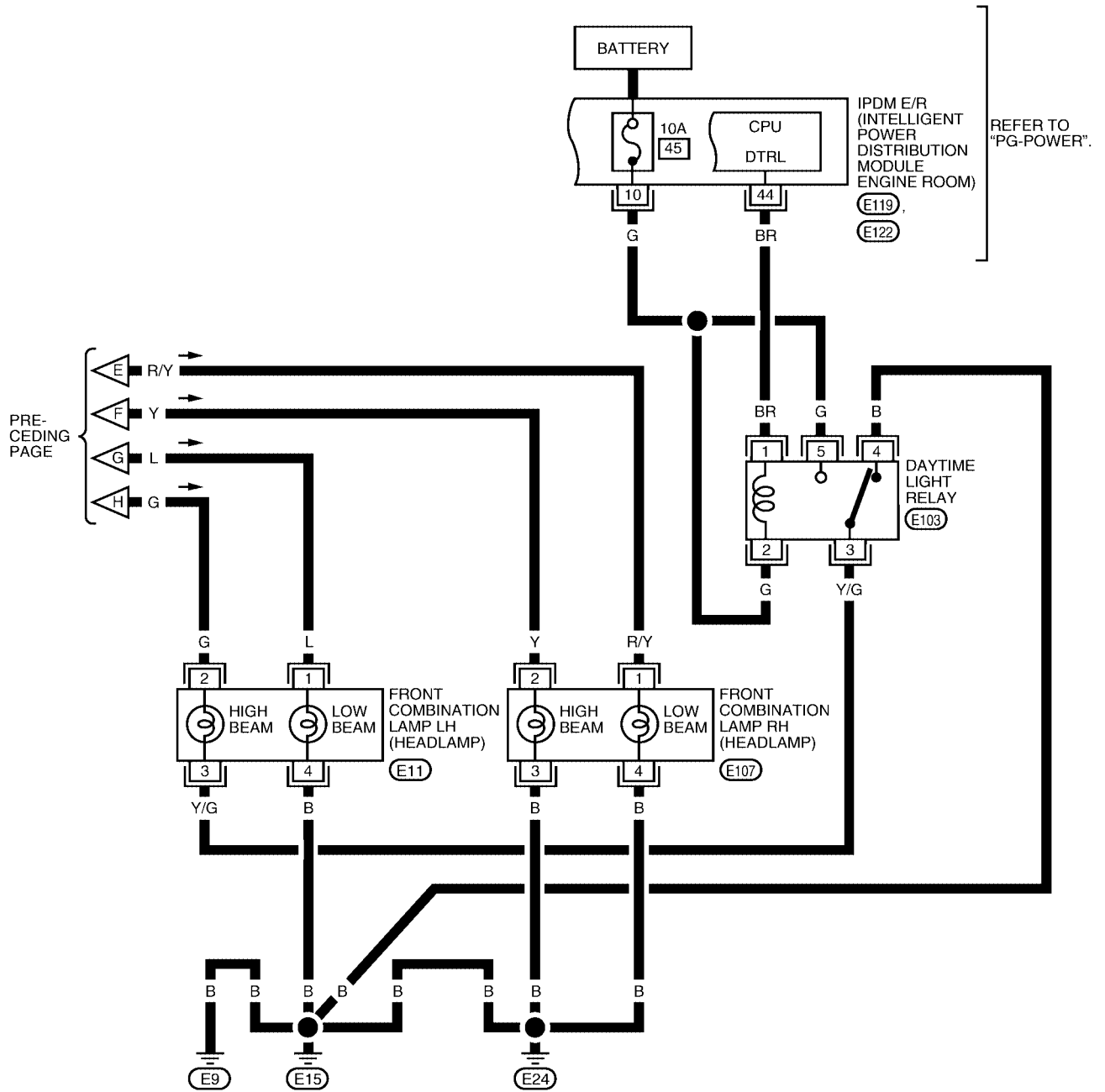

PRE-  
CEDING  
PAGE

REFER TO  
"PG-POWER".

A  
B  
C  
D  
E  
F  
G  
H  
I  
J  
LT  
L  
M

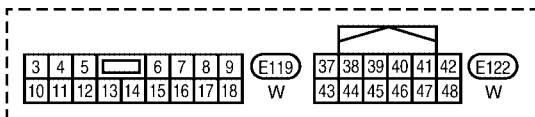
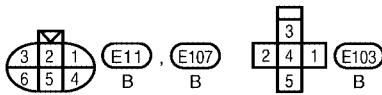





WKWA2401E

# HEADLAMP (FOR CANADA) - DAYTIME LIGHT SYSTEM -

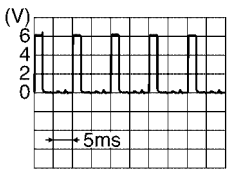
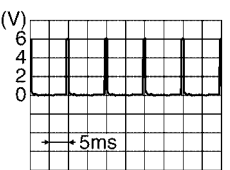
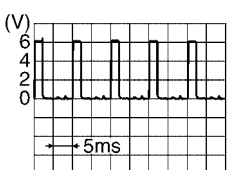
## Terminals and Reference Values for BCM

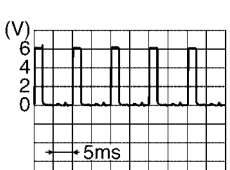
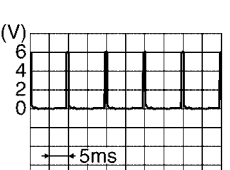
EKS00A9L

Terminal No.	Wire color	Signal name	Measuring condition		Reference value (Approx.)
			Ignition switch	Operation or condition	
2	SB	Combination switch input 5	ON	Lighting, turn, wiper OFF Wiper dial position 4	 <p style="text-align: right;">SKIA5291E</p>
3	G/Y	Combination switch input 4	ON	Lighting, turn, wiper OFF Wiper dial position 4	 <p style="text-align: right;">SKIA5292E</p>
4	Y	Combination switch input 3	ON	Lighting, turn, wiper OFF Wiper dial position 4	 <p style="text-align: right;">SKIA5291E</p>
5	G/B	Combination switch input 2	ON	Lighting, turn, wiper OFF Wiper dial position 4	 <p style="text-align: right;">SKIA5292E</p>
6	V	Combination switch input 1			
32	R/G	Combination switch output 5	ON	Lighting, turn, wiper OFF Wiper dial position 4	 <p style="text-align: right;">SKIA5291E</p>
33	R/Y	Combination switch output 4	ON	Lighting, turn, wiper OFF Wiper dial position 4	 <p style="text-align: right;">SKIA5292E</p>
34	L	Combination switch output 3	ON	Lighting, turn, wiper OFF Wiper dial position 4	 <p style="text-align: right;">SKIA5291E</p>

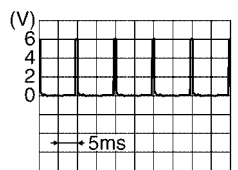

# HEADLAMP (FOR CANADA) - DAYTIME LIGHT SYSTEM -

Terminal No.	Wire color	Signal name	Measuring condition		Reference value (Approx.)
			Ignition switch	Operation or condition	
35	O/B	Combination switch output 2	ON	Lighting, turn, wiper OFF Wiper dial position 4	
36	R/W	Combination switch output 1			
38	W/L	Ignition switch (ON)	ON	—	Battery voltage
39	L	CAN-H	—	—	—
40	P	CAN-L	—	—	—
67	B	Ground	ON	—	0V
70	W/B	Battery power supply (fusible link)	OFF	—	Battery voltage

## How to Proceed With Trouble Diagnosis

EKS00A9M

1. Confirm the symptom or customer complaint.
2. Understand operation description and function description. Refer to [LT-33, "System Description"](#).
3. Perform the Preliminary Check. Refer to [LT-41, "Preliminary Check"](#).
4. Check symptom and repair or replace the cause of malfunction.
5. Does the headlamp operate normally? If YES: GO TO 6. If NO: GO TO 4.
6. Inspection End.

## Preliminary Check

EKS00A9N

### CHECK BCM CONFIGURATION

#### 1. CHECK BCM CONFIGURATION

Confirm BCM configuration for "DTRL" is set to "WITH". Refer to [BCS-13, "READ CONFIGURATION PROCEDURE"](#).

OK or NG

OK >> Continue preliminary check. Refer to [LT-41, "INSPECTION FOR POWER SUPPLY AND GROUND CIRCUIT"](#).

NG >> Change BCM configuration for "DTRL" to "WITH". Refer to [BCS-16, "WRITE CONFIGURATION PROCEDURE"](#).

### INSPECTION FOR POWER SUPPLY AND GROUND CIRCUIT

#### 1. CHECK FUSES AND FUSIBLE LINK

Check for blown fuses or fusible link.

Unit	Power source	Fuse No.
BCM	Battery	f
	Ignition switch ON or START position	59
Daytime light relay	Battery	45

Refer to [LT-36, "Wiring Diagram — DTRL —"](#).

OK or NG

OK >> GO TO 2.

NG >> If fuse is blown, be sure to eliminate cause of malfunction before installing new fuse. Refer to [PG-4, "POWER SUPPLY ROUTING CIRCUIT"](#).

# HEADLAMP (FOR CANADA) - DAYTIME LIGHT SYSTEM -

## 2. CHECK POWER SUPPLY CIRCUIT

1. Disconnect BCM connectors.
2. Check voltage between BCM harness connector and ground.

Terminals		Ignition switch position			
(+)		(-)	OFF	ACC	ON
Connector	Terminal (Wire color)		OFF	ACC	ON
M18	38 (W/L)	Ground	0V	0V	Battery voltage
M20	70 (W/B)		Battery voltage	Battery voltage	Battery voltage

OK or NG

OK >> GO TO 3.

NG >> Check harness for open or short between BCM and fuse.

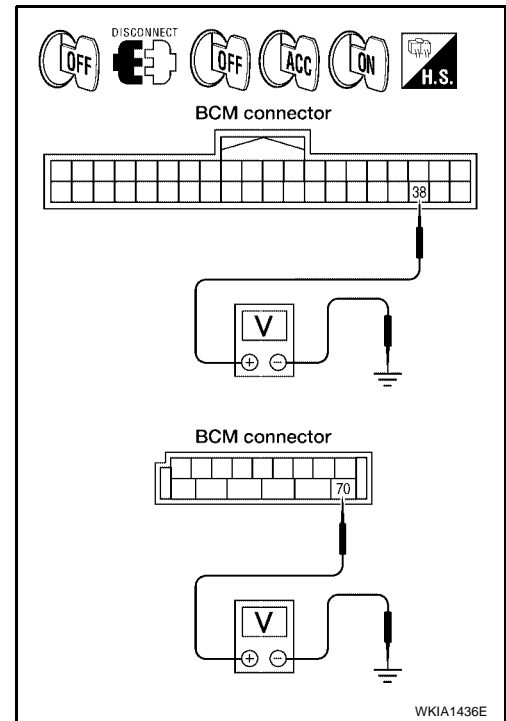

## 3. CHECK GROUND CIRCUIT

Check continuity between BCM harness connector and ground.

Terminals		Continuity
Connector	Terminal (Wire color)	
M20	67 (B)	Ground Yes

OK or NG

OK >> Inspection End.

NG >> Check ground circuit harness.

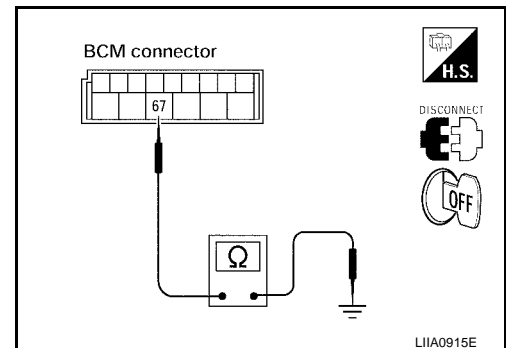

## INSPECTION PARKING BRAKE SWITCH CIRCUIT

### 1. CHECK BRAKE INDICATOR

1. Turn ignition switch ON.
2. Apply parking brake.
3. Release parking brake.

**Brake indicator in combination meter should illuminate when parking brake is applied and turn OFF when released.**

OK or NG

OK >> Inspection End.

NG >> GO TO 2.

# HEADLAMP (FOR CANADA) - DAYTIME LIGHT SYSTEM -

## 2. CHECK PARKING BRAKE SWITCH SIGNAL

1. Disconnect parking brake switch connector.
2. Turn ignition switch ON.
3. Check voltage between parking brake switch harness connector M11 terminal + (G) and ground.

**+ (G) - Ground : Battery voltage should exist.**

OK or NG

- OK >> Replace parking brake switch.  
NG >> GO TO 3.

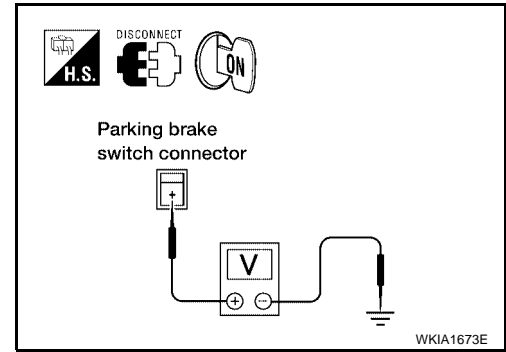

## 3. CHECK PARKING BRAKE SWITCH CIRCUIT

1. Turn ignition switch OFF.
2. Disconnect combination meter connector.
3. Check continuity between combination meter harness connector M24 terminal 23 (G) and parking brake switch harness connector M11 terminal + (G).

**+ (G) - 23 (G) : Continuity should exist.**

OK or NG

- OK >> Replace combination meter. Refer to [IP-13, "COMBINATION METER"](#).  
NG >> Repair harness or connector.

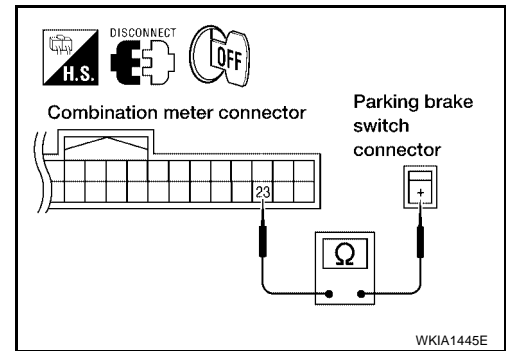

## CONSULT-II Functions

Refer to [LT-17, "CONSULT-II Function \(BCM\)"](#) in HEADLAMP (FOR USA).

Refer to [LT-20, "CONSULT-II Function \(IPDM E/R\)"](#) in HEADLAMP (FOR USA).

## Daytime Light Control Does Not Operate Properly (Normal Headlamps Operate Properly)

### 1. CHECK DAYTIME LIGHT RELAY POWER SUPPLY CIRCUIT

1. Remove daytime light relay.
2. Check voltage between daytime light relay harness connector E103 terminals 2 (G), 5 (G) and ground.

**2 (G), 5 (G) - Ground : Battery voltage should exist.**

OK or NG

- OK >> GO TO 2.  
NG >> Repair harness or connector.

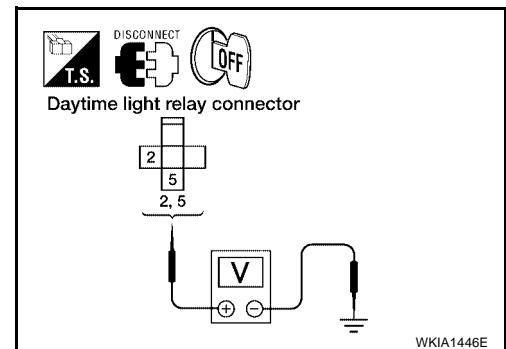

# HEADLAMP (FOR CANADA) - DAYTIME LIGHT SYSTEM -

## 2. CHECK DAYTIME LIGHT RELAY

1. Apply battery voltage to daytime light relay terminal 2 and ground terminal 1.
2. Check continuity between terminals 3 and 5.

**3 - 5 : Continuity should exist.**

OK or NG

- OK >> GO TO 3.  
 NG >> Replace daytime light relay.

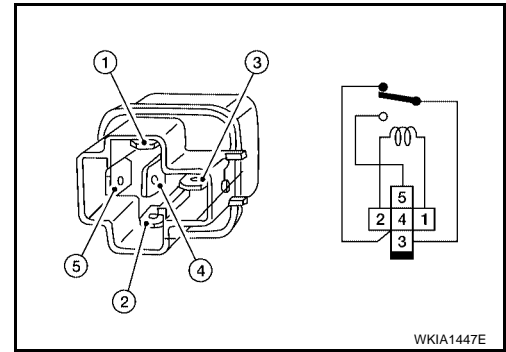

WKIA1447E

## 3. CHECK DAYTIME LIGHT RELAY CIRCUIT

1. Disconnect front combination lamp LH connector.
2. Check continuity between daytime light relay connector E103 terminal 3 (Y/G) and front combination lamp LH harness connector E11 terminal 3 (Y/G).

**3 (Y/G) - 3 (Y/G) : Continuity should exist.**

OK or NG

- OK >> GO TO 4.  
 NG >> Repair harness or connector.

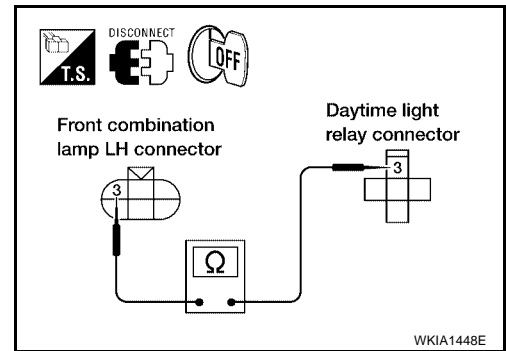

WKIA1448E

## 4. CHECK INPUT SIGNAL

1. Connect daytime light relay and front combination lamp LH connector.
2. Start engine and release parking brake. Headlamp switch OFF.
3. Select "IPDM E/R" on CONSULT-II. With data monitor, make sure "DTRL REQ" turns ON-OFF linked with operation of parking brake switch.

**Parking brake ON : DTRL REQ ON**  
**Parking brake OFF : DTRL REQ OFF**

OK or NG

- OK >> Replace IPDM E/R. Refer to [PG-28, "Removal and Installation of IPDM E/R"](#).  
 NG >> GO TO 5.

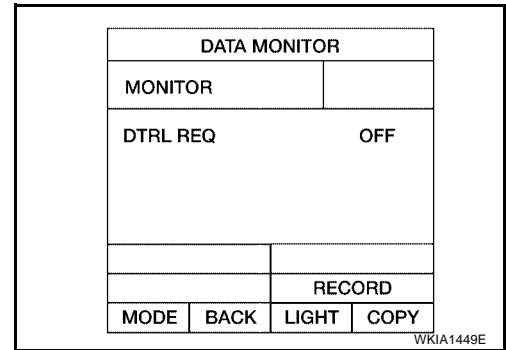

WKIA1449E

## 5. CHECKING CAN COMMUNICATIONS

Select "BCM" on CONSULT-II and perform self-diagnosis for BCM.

Displayed self-diagnosis results

NO DTC>>Replace BCM. Refer to [BCS-19, "Removal and Installation of BCM"](#).

CAN COMM CIRCUIT>> Check BCM CAN communication system. Refer to [BCS-13, "CAN Communication Inspection Using CONSULT-II \(Self-Diagnosis\)"](#).

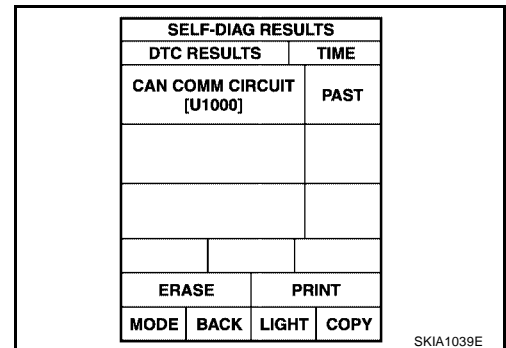

SKIA1039E

# HEADLAMP (FOR CANADA) - DAYTIME LIGHT SYSTEM -

---

## Aiming Adjustment

EKS00A9Q

Refer to [LT-29, "Aiming Adjustment"](#) .

A

## Bulb Replacement

EKS00A9R

Refer to [LT-31, "Disassembly and Assembly"](#) .

B

## Removal and Installation

EKS00A9S

Refer to [LT-31, "Removal and Installation"](#) .

C

## Disassembly and Assembly

EKS00A9T

Refer to [LT-31, "Disassembly and Assembly"](#) .

D

E

F

G

H

I

J

LT

L

M

# AUTO LIGHT SYSTEM

## AUTO LIGHT SYSTEM

PF2:28491

### Component Parts and Harness Connector Location

EKS00A9U

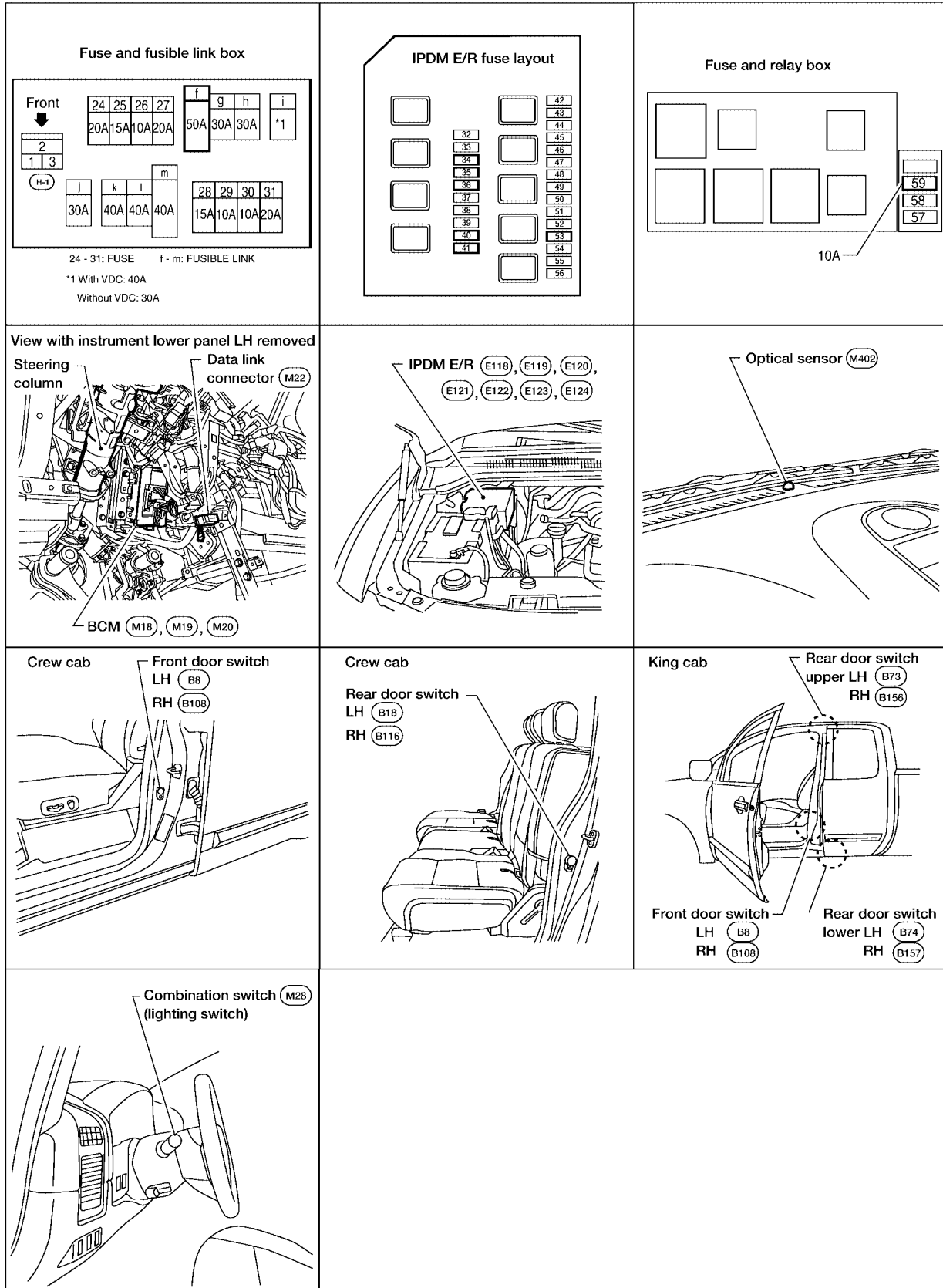

WKIA3581E

# AUTO LIGHT SYSTEM

## System Description

EKS00A9V

Automatically turns on/off the parking lamps and the headlamps in accordance with ambient light. Timing for when the lamps turn on/off can be selected using four modes.

### OUTLINE

The auto light control system uses an optical sensor that detects outside brightness.

When the lighting switch is in "AUTO" position, it automatically turns on/off the parking lamps and the headlamps in accordance with the ambient light. Sensitivity can be adjusted in four steps. For the details of the setting, refer to [LT-54, "SETTING CHANGE FUNCTIONS"](#).

Optical sensor ground is supplied

- to optical sensor terminal 3
- through BCM (body control module) terminal 18.

When ignition switch is turned to "ON" position and when outside brightness is darker than prescribed level, input is supplied

- to BCM terminal 58
- through optical sensor terminal 4.

The headlamps will then illuminate. For a description of headlamp operation, refer to [LT-5, "System Description"](#).

### COMBINATION SWITCH READING FUNCTION

Refer to [BCS-3, "COMBINATION SWITCH READING FUNCTION"](#).

### EXTERIOR LAMP BATTERY SAVER CONTROL

When the combination switch (lighting switch) is in the AUTO position, and the ignition switch is turned from ON or ACC to OFF, and one of the front doors is opened, the battery saver control feature is activated.

Under this condition, the headlamps remain illuminated for 5 minutes, then the headlamps are turned off.

Exterior lamp battery saver control mode can be changed by the function setting of CONSULT-II.

### DELAY TIMER FUNCTION

When the ignition switch is ON and auto light switch is ON, the BCM turns on/off the headlamps. In delay timer function, ignition is OFF, auto light sensor power source is OFF and the headlamps are not turned on/off by the BCM. On condition that:

- when the state of ignition switch ON or ACC is ON and output judgment by auto light function is headlamp ON changes to ignition switch and ACC are OFF and any door switch is ON, output judgment by BCM should be headlamp ON for 5 minutes by timer. After time out, output judgment by BCM should be headlamp OFF.
- when the state of any door switch is turned to ON from OFF while 45 second or 5 minute timer is counting, timer stops, and restarts counting for 5 minutes, then BCM judges output as headlamp ON. After time out, BCM judges output as headlamp OFF.
- when the state of front door switch (driver side), front door switch (passenger side), rear door switch LH, rear door switch RH or back door latch (door ajar switch) is ON turns to all door switches are OFF while 45 second or 5 minute timer is counting, timer stops, and restarts counting for 45 seconds, then BCM judges output as headlamp ON. After timer out, BCM judges output as headlamp OFF.
- when the state is ignition switch ON or ACC is ON or auto light switch OFF while timer is counting, timer stops counting and BCM turns on/off lamps according to headlamp function, front fog lamp function, auto light function and headlamp battery save function.

Delay timer control mode can be changed by the function setting of CONSULT-II.

## CAN Communication System Description

EKS00A9W

Refer to [LAN-7, "CAN COMMUNICATION"](#).

## Major Components and Functions

EKS00A9X

Components	Functions
BCM	● Turns on/off circuits of tail light and headlamp according to signals from light sensor, lighting switch (AUTO), driver door switch, passenger door switch, rear door switch, and ignition switch (ON, OFF).
Optical sensor	● Converts ambient light (lux) to voltage, and sends it to BCM. (Detects lightness of 50 to 1,300 lux)

# AUTO LIGHT SYSTEM

## Schematic

EKS00A9Y

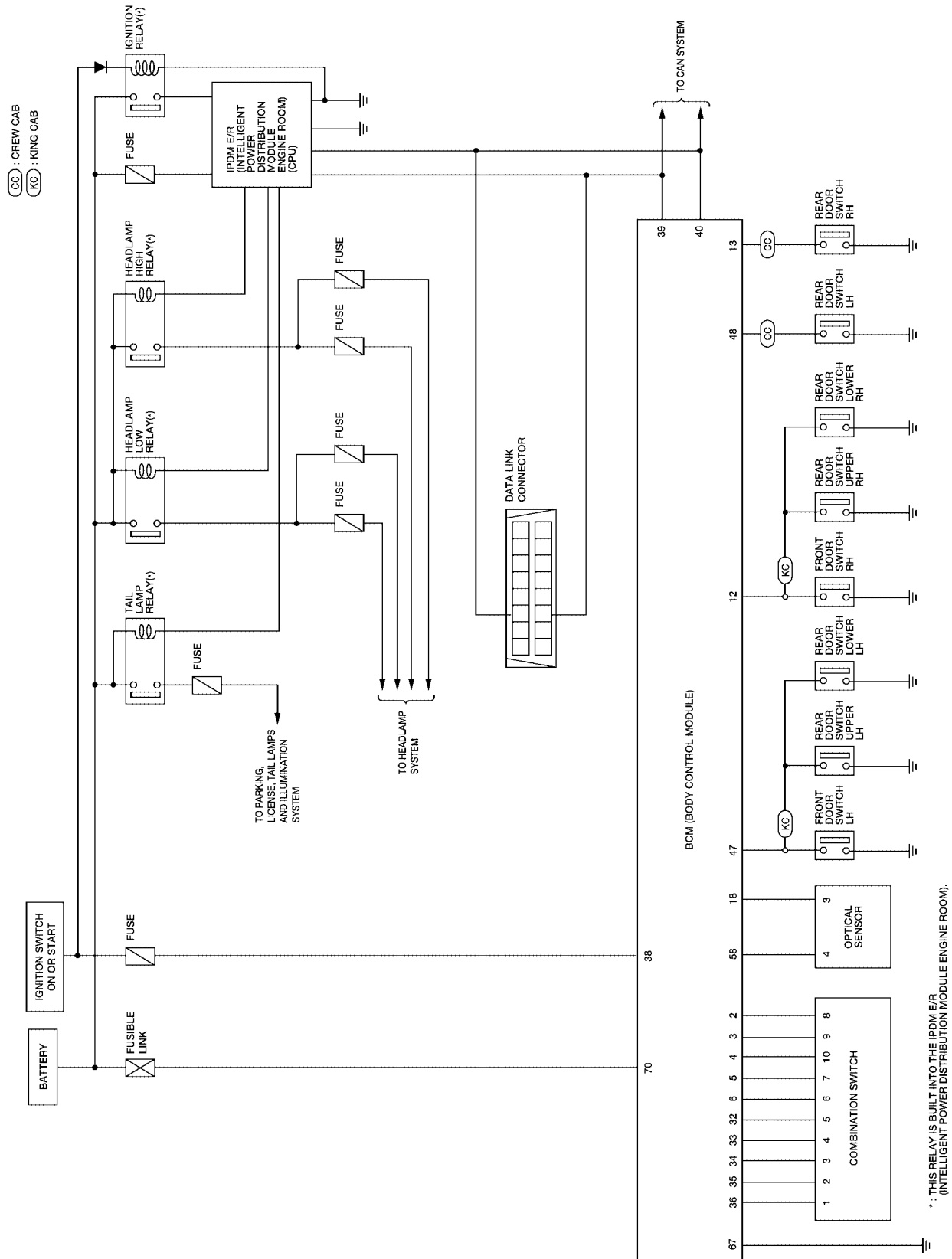

WKWA2443E



# AUTO LIGHT SYSTEM

## Wiring Diagram — AUTO/L —

EKS00A9Z

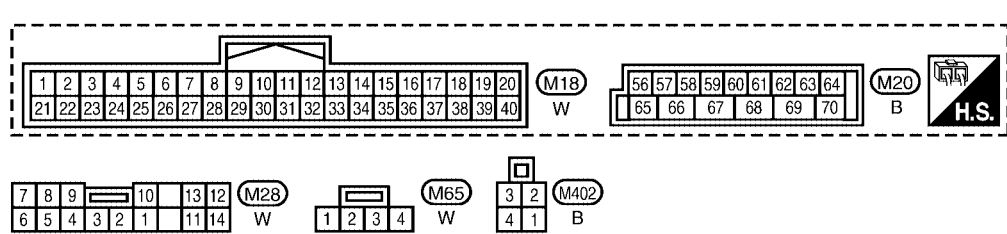
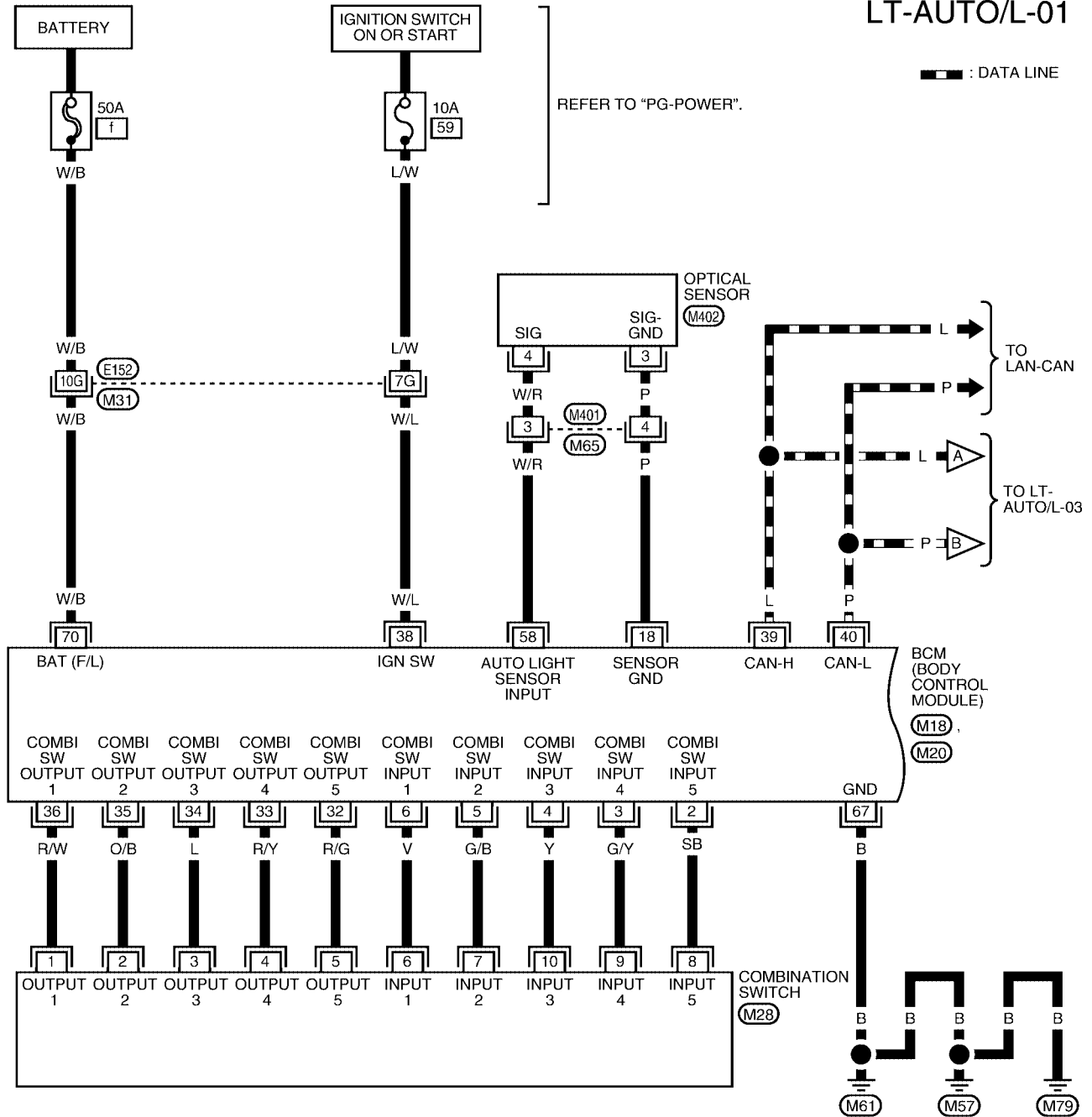

REFER TO THE FOLLOWING.  
**M31** - SUPER MULTIPLE JUNCTION (SMJ)

WKWA2444E

# AUTO LIGHT SYSTEM

LT-AUTO/L-02

CC : CREW CAB  
KC : KING CAB

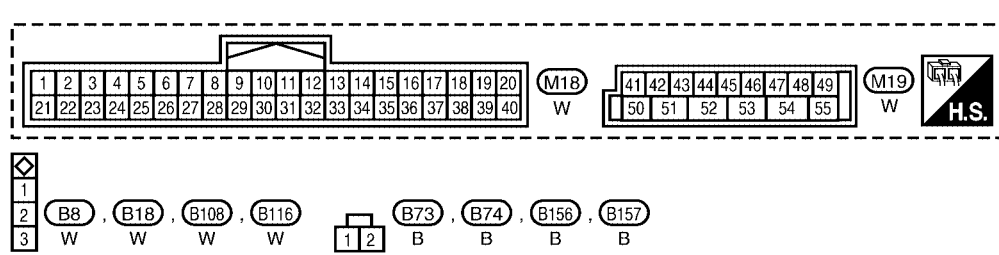
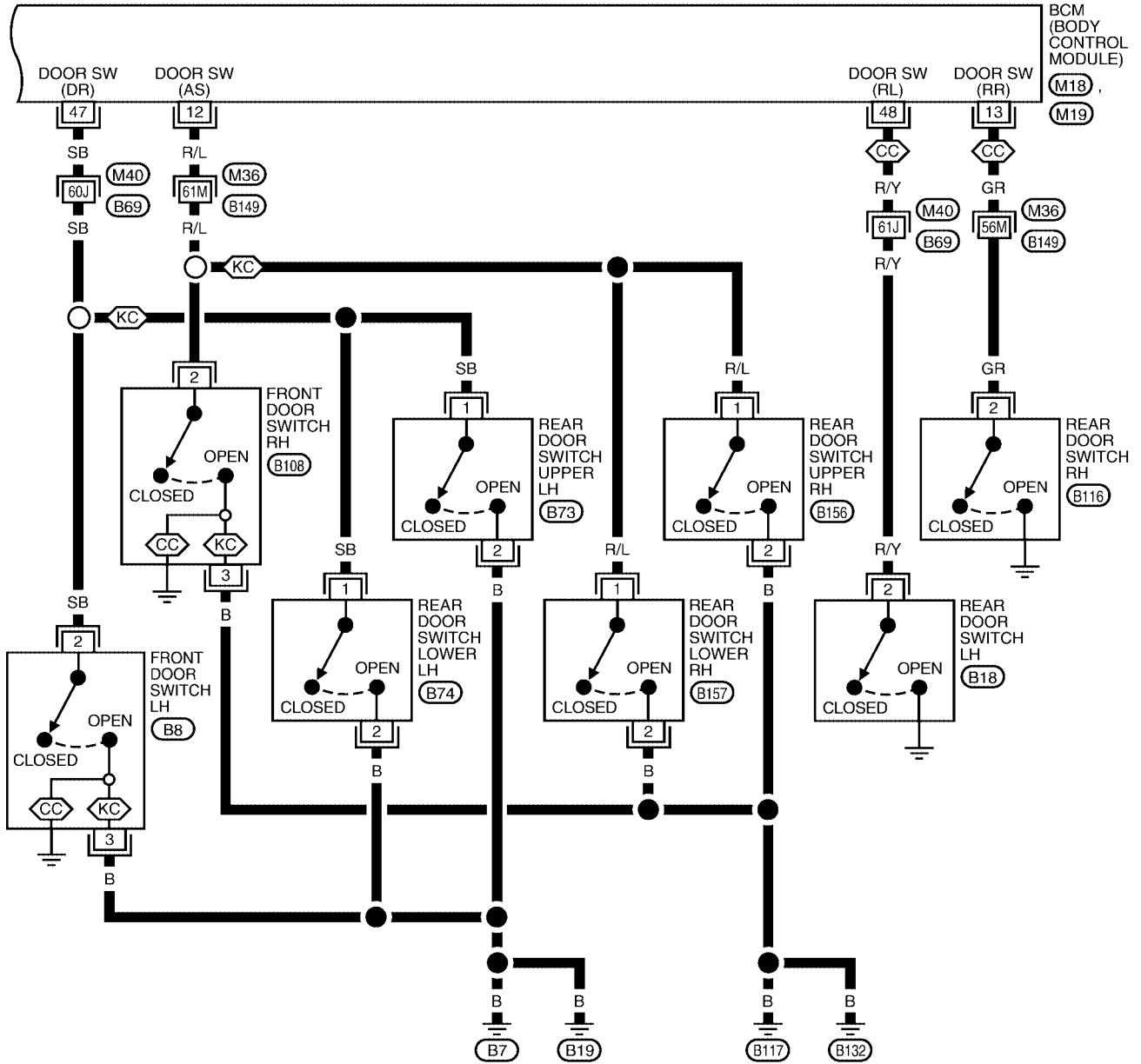

REFER TO THE FOLLOWING.  
M36, M40 - SUPER  
 MULTIPLE JUNCTION (SMJ)

LKWA0282E

# AUTO LIGHT SYSTEM

LT-AUTO/L-03

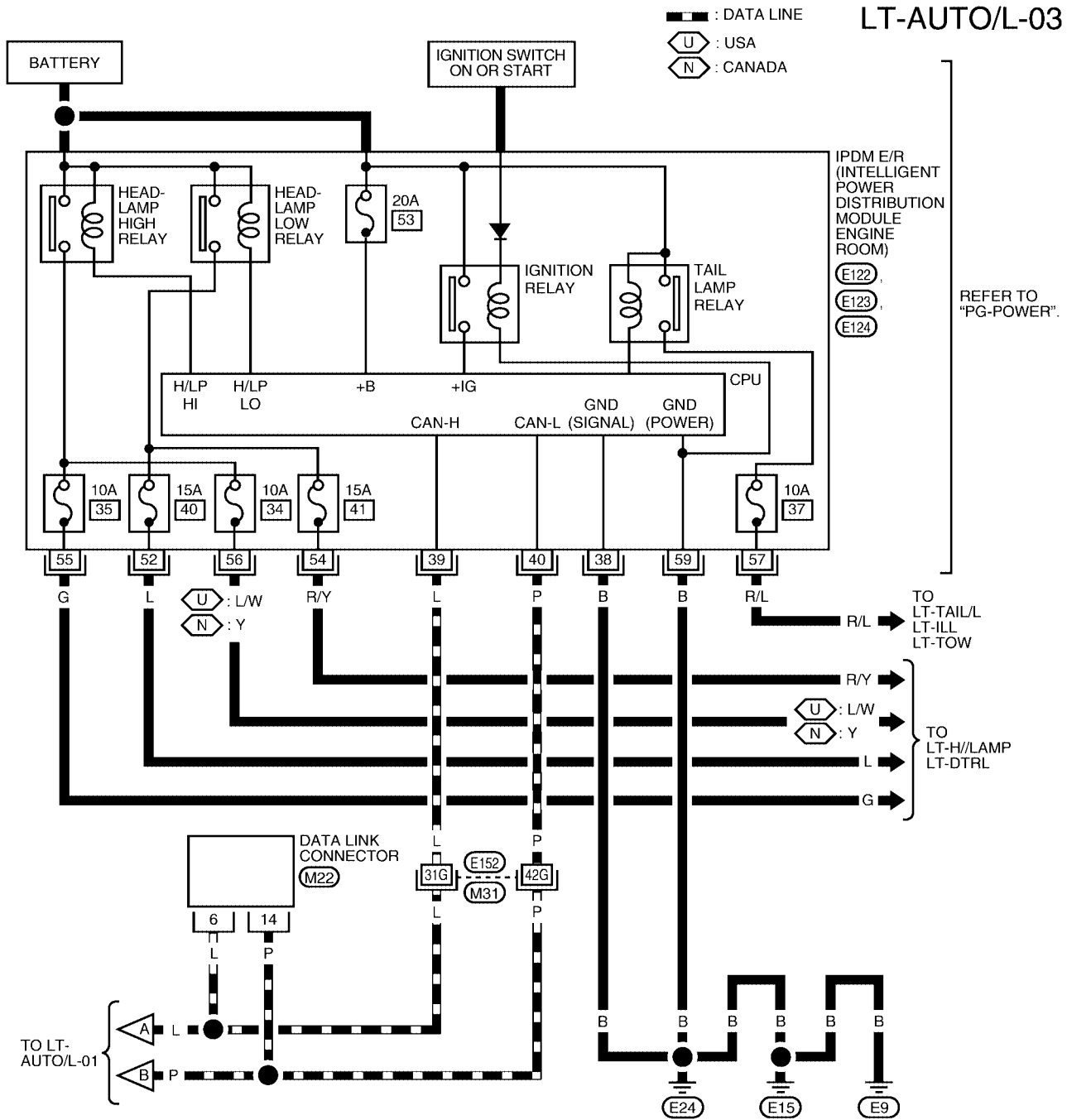

A  
B  
C  
D  
E  
F  
G  
H  
I  
J  
LT  
L  
M

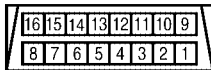

(M22) W

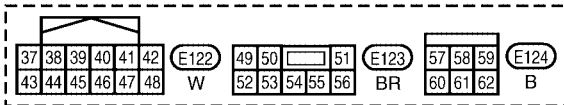

(E122) W





(E123) BR

(E124) B

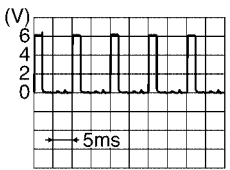
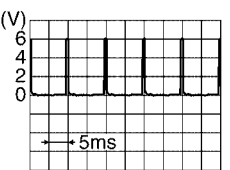
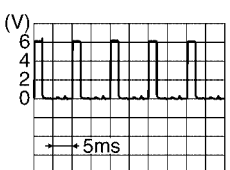

# AUTO LIGHT SYSTEM

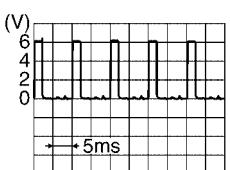
## Terminals and Reference Values for BCM

EKS00AA0

Terminal No.	Wire color	Signal name	Measuring condition		Reference value (Approx.)				
			Ignition switch	Operation or condition					
2	SB	Combination switch input 5	ON	Lighting, turn, wiper OFF Wiper dial position 4	 <p style="text-align: right;">SKIA5291E</p>				
3	G/Y	Combination switch input 4	ON	Lighting, turn, wiper OFF Wiper dial position 4	 <p style="text-align: right;">SKIA5292E</p>				
4	Y	Combination switch input 3	ON	Lighting, turn, wiper OFF Wiper dial position 4	 <p style="text-align: right;">SKIA5291E</p>				
5	G/B	Combination switch input 2	ON	Lighting, turn, wiper OFF Wiper dial position 4	 <p style="text-align: right;">SKIA5292E</p>				
6	V	Combination switch input 1							
12 <sup>1</sup>	R/L	Front door switch RH signal	OFF	Front door switch RH	<table border="1" style="width: 100%; border-collapse: collapse;"> <tr> <td style="width: 50%;">ON (open)</td> <td style="text-align: center;">0V</td> </tr> <tr> <td>OFF (closed)</td> <td style="text-align: center;">Battery voltage</td> </tr> </table>	ON (open)	0V	OFF (closed)	Battery voltage
ON (open)	0V								
OFF (closed)	Battery voltage								
12 <sup>2</sup>	R/L	Door switch RH signal	OFF	Door switch RH	<table border="1" style="width: 100%; border-collapse: collapse;"> <tr> <td style="width: 50%;">ON (open)</td> <td style="text-align: center;">0V</td> </tr> <tr> <td>OFF (closed)</td> <td style="text-align: center;">Battery voltage</td> </tr> </table>	ON (open)	0V	OFF (closed)	Battery voltage
ON (open)	0V								
OFF (closed)	Battery voltage								
13 <sup>1</sup>	GR	Rear door switch RH signal	OFF	Rear door switch RH	<table border="1" style="width: 100%; border-collapse: collapse;"> <tr> <td style="width: 50%;">ON (open)</td> <td style="text-align: center;">0V</td> </tr> <tr> <td>OFF (closed)</td> <td style="text-align: center;">Battery voltage</td> </tr> </table>	ON (open)	0V	OFF (closed)	Battery voltage
ON (open)	0V								
OFF (closed)	Battery voltage								
18	P	Sensor ground	ON	—	0V				
32	R/G	Combination switch output 5	ON	Lighting, turn, wiper OFF Wiper dial position 4	 <p style="text-align: right;">SKIA5291E</p>				
33	R/Y	Combination switch output 4	ON	Lighting, turn, wiper OFF Wiper dial position 4	 <p style="text-align: right;">SKIA5292E</p>				

# AUTO LIGHT SYSTEM

Terminal No.	Wire color	Signal name	Measuring condition		Reference value (Approx.)	
			Ignition switch	Operation or condition		
34	L	Combination switch output 3	ON	Lighting, turn, wiper OFF Wiper dial position 4	 SKIA5291E	
35	O/B	Combination switch output 2	ON	Lighting, turn, wiper OFF Wiper dial position 4	 SKIA5292E	
36	R/W	Combination switch output 1				
38	W/L	Ignition switch (ON)	ON	—	Battery voltage	
39	L	CAN-H	—	—	—	
40	P	CAN-L	—	—	—	
47 <sup>1</sup>	SB	Front door switch LH signal	OFF	Front door switch LH	ON (open)	0V
					OFF (closed)	Battery voltage
47 <sup>2</sup>	SB	Door switch LH signal	OFF	Door switch LH	ON (open)	0V
					OFF (closed)	Battery voltage
48 <sup>1</sup>	R/Y	Rear door switch LH signal	OFF	Rear door switch LH	ON (open)	0V
					OFF (closed)	Battery voltage
58	W/R	Optical sensor signal	ON	When optical sensor is illuminated	3.1V or more <sup>Note</sup>	
				When optical sensor is not illuminated	0.6V or less	
67	B	Ground	ON	—	0V	
70	W/B	Battery power supply	OFF	—	Battery voltage	

1 Crew cab

2 King cab

**NOTE:**

Optical sensor must be completely subjected to work lamp light. If the optical sensor is insufficiently illuminated, the measured value may not satisfy standard.

## Terminals and Reference Values for IPDM E/R

EKS00AA1

Terminal No.	Wire color	Signal name	Measuring condition		Reference value (Approx.)	
			Ignition switch	Operation or condition		
38	B	Ground	ON	—	0V	
39	L	CAN-H	—	—	—	
40	P	CAN-L	—	—	—	
52	L	Headlamp low (LH)	ON	Lighting switch 2ND position	OFF	0V
					ON	Battery voltage
54	R/Y	Headlamp low (RH)	ON	Lighting switch 2ND position	OFF	0V
					ON	Battery voltage

# AUTO LIGHT SYSTEM

Terminal No.	Wire color	Signal name	Measuring condition		Reference value (Approx.)
			Ignition switch	Operation or condition	
55	G	Headlamp high (LH)	ON	Lighting switch HIGH or PASS position	OFF 0V
				ON	Battery voltage
56	L/W <sup>1</sup> Y <sup>2</sup>	Headlamp high (RH)	ON	Lighting switch HIGH or PASS position	OFF 0V
				ON	Battery voltage
57	R/L	Parking, license, and tail lamp	ON	Lighting switch 1ST position	OFF 0V
				ON	Battery voltage
59	B	Ground	ON	—	0V

1 USA

2 Canada

## How to Proceed With Trouble Diagnosis

EKS00AA2

1. Confirm the symptom or customer complaint.
2. Understand operation description and function description. Refer to [LT-47, "System Description"](#).
3. Carry out the Preliminary Check. Refer to [LT-54, "Preliminary Check"](#).
4. Check symptom and repair or replace the cause of malfunction. Refer to [LT-61, "Trouble Diagnosis Chart by Symptom"](#).
5. Does the auto light system operate normally? If YES: GO TO 6. If NO: GO TO 4.
6. Inspection End.

## Preliminary Check

EKS00AA3

### SETTING CHANGE FUNCTIONS

- Sensitivity of auto light system can be adjusted using CONSULT-II. Refer to [LT-57, "WORK SUPPORT"](#).

### CHECK BCM CONFIGURATION

#### 1. CHECK BCM CONFIGURATION

Confirm BCM configuration for "AUTO LIGHT" is set to "WITH". Refer to [BCS-13, "READ CONFIGURATION PROCEDURE"](#).

#### OK or NG

- OK >> Continue preliminary check. Refer to [LT-54, "CHECK POWER SUPPLY AND GROUND CIRCUIT"](#).
- NG >> Change BCM configuration for "AUTO LIGHT" to "WITH". Refer to [BCS-16, "WRITE CONFIGURATION PROCEDURE"](#).

### CHECK POWER SUPPLY AND GROUND CIRCUIT

#### 1. CHECK FUSES OR FUSIBLE LINK

Check for blown fuses or fusible link.

Unit	Power source	Fuse No.
BCM	Battery	f
	Ignition switch ON or START position	59
IPDM E/R	Battery	34
		35
		40
		41
		53

# AUTO LIGHT SYSTEM

Refer to [LT-49, "Wiring Diagram — AUTO/L —"](#) .

**OK or NG**

OK >> GO TO 2.

NG >> If fuse is blown, be sure to eliminate cause of malfunction before installing new fuse. Refer to [PG-4, "POWER SUPPLY ROUTING CIRCUIT"](#) .

## 2. CHECK POWER SUPPLY CIRCUIT

1. Disconnect BCM connectors.
2. Check voltage between BCM harness connector and ground.

Terminals		(-)	Ignition switch position		
Connector	Terminal (Wire color)		OFF	ACC	ON
M18	38 (W/L)	Ground	0V	0V	Battery voltage
M20	70 (W/B)		Battery voltage	Battery voltage	Battery voltage

**OK or NG**

OK >> GO TO 3.

NG >> Check harness for open between BCM and fuse.

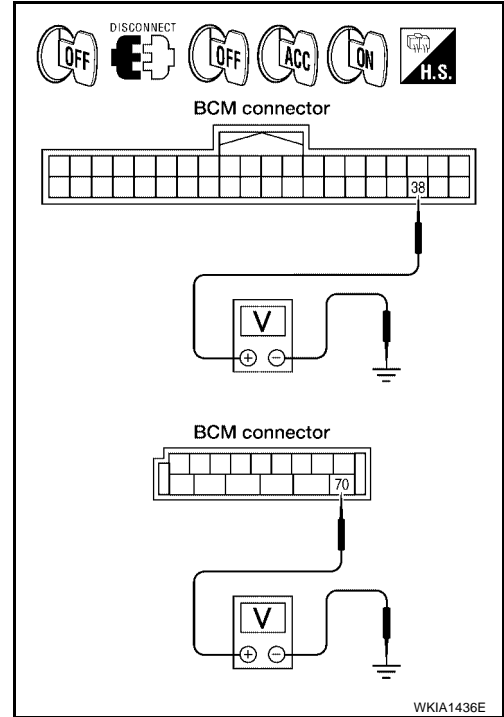

## 3. CHECK GROUND CIRCUIT

Check continuity between BCM harness connector and ground.

Terminals			Continuity
Connector	Terminal (Wire color)		
M20	67 (B)	Ground	Yes

**OK or NG**

OK >> Inspection End.

NG >> Check ground circuit harness.

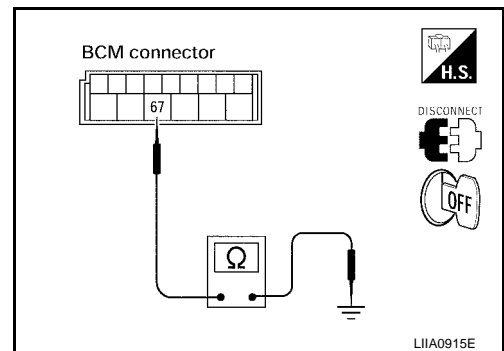

# AUTO LIGHT SYSTEM

## CONSULT-II Function (BCM)

EKS00AA4

CONSULT-II can display each diagnostic item using the diagnostic test modes shown following.

BCM diagnostic test item	Diagnostic mode	Description
Inspection by part	WORK SUPPORT	Supports inspections and adjustments. Commands are transmitted to the BCM for setting the status suitable for required operation, input/output signals are received from the BCM and received data is displayed.
	DATA MONITOR	Displays BCM input/output data in real time.
	ACTIVE TEST	Operation of electrical loads can be checked by sending drive signal to them.
	SELF-DIAG RESULTS	Displays BCM self-diagnosis results.
	CAN DIAG SUPPORT MNTR	The result of transmit/receive diagnosis of CAN communication can be read.
	ECU PART NUMBER	BCM part number can be read.
	CONFIGURATION	Performs BCM configuration read/write functions.

## CONSULT-II OPERATION

### CAUTION:

If CONSULT-II is used with no connection of CONSULT-II CONVERTER, malfunctions might be detected in self-diagnosis depending on control unit which carries out CAN communication.

1. With the ignition switch OFF, connect CONSULT-II and CONSULT-II CONVERTER to the data link connector, then turn ignition switch ON.

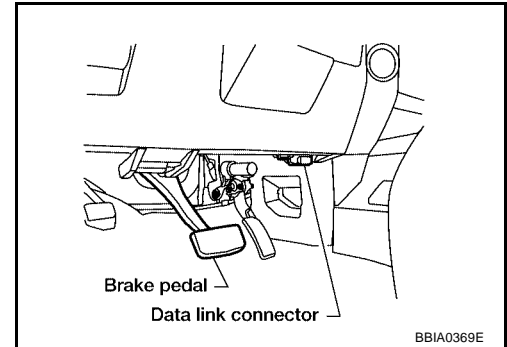

2. Touch "START (NISSAN BASED VHCL)".

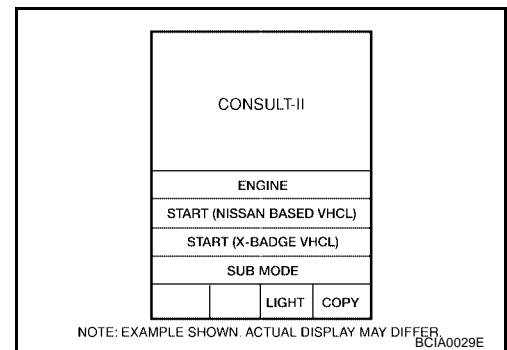

3. Touch "BCM" on "SELECT SYSTEM" screen.  
If "BCM" is not indicated, go to [GI-38, "CONSULT-II Data Link Connector \(DLC\) Circuit"](#).

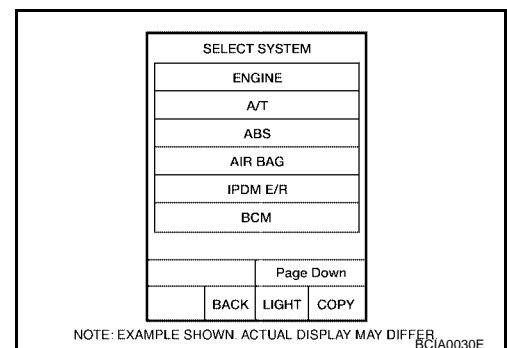



# AUTO LIGHT SYSTEM

4. Touch "HEAD LAMP" on "SELECT TEST ITEM" screen.

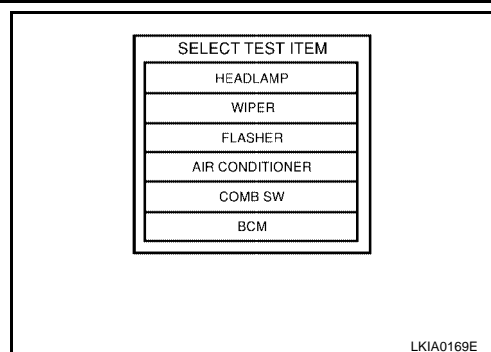

## WORK SUPPORT

### Operation Procedure

1. Touch "HEAD LAMP" on "SELECT TEST ITEM" screen.
2. Touch "WORK SUPPORT" on "SELECT DIAG MODE" screen.
3. Touch "CUSTOM A/LIGHT SETTING" or "ILL DELAY SET" on "SELECT WORK ITEM" screen.
4. Touch "START".
5. Touch "MODE 1-4" of setting to be changed (CUSTOM A/LIGHT SETTING). Touch "MODE 1-8" of setting to be changed (ILL DELAY SET).
6. Touch "CHANGE SETT".
7. The setting will be changed and "CUSTOMIZING COMPLETED" will be displayed.
8. Touch "END".

### Work Support Setting Item

- Sensitivity of auto light can be selected and set from four modes.

Work item	Description
CUSTOM A/LIGHT SETTING	Auto light sensitivity can be changed in this mode. Sensitivity can be adjusted in four modes. ● MODE 1 (Normal-default)/ MODE 2 (Desensitized)/MODE 3 (Sensitive)/MODE4 (Insensitive)
ILL DELAY SET	Auto light delay off timer period can be changed in this mode. Selects auto light delay off timer period among eight modes. ● MODE 1 (45 sec.)/MODE 2 (OFF)/MODE 3 (30 sec.)/MODE 4 (60 sec.)/MODE 5 (90 sec.)/MODE 6 (120 sec.)/MODE 7 (150 sec.)/MODE 8 (180 sec.)

## DATA MONITOR

### Operation Procedure

1. Touch "HEAD LAMP" on "SELECT TEST ITEM" screen.
2. Touch "DATA MONITOR" on "SELECT DIAG MODE" screen.
3. Touch either "ALL SIGNALS" or "SELECTION FROM MENU" on the "SELECT MONITOR ITEM" screen.

All signals	Monitors all the signals.
Selection from menu	Selects and monitors individual signal.

4. Touch "START".
5. When "SELECTION FROM MENU" is selected, touch individual items to be monitored. When "ALL SIGNALS" is selected, all the items will be monitored.
6. Touch "RECORD" while monitoring, then the status of the monitored item can be recorded. To stop recording, touch "STOP".

### Display Item List

Monitor item	Contents
IGN ON SW "ON/OFF"	Displays "IGN position (ON)/OFF, ACC position (OFF)" judged from the ignition switch signal.
ACC ON SW "ON/OFF"	Displays "ACC (ON)/OFF, Ignition OFF (OFF)" status judged from ignition switch signal.
HI BEAM SW "ON/OFF"	Displays status (high beam switch: ON/Others: OFF) of high beam switch judged from lighting switch signal.

# AUTO LIGHT SYSTEM

Monitor item	Contents
HEAD LAMP SW 1 "ON/OFF"	Displays status (headlamp switch 1: ON/Others: OFF) of headlamp switch 2 judged from lighting switch signal.
HEAD LAMP SW 2 "ON/OFF"	Displays status (headlamp switch 2: ON/Others: OFF) of headlamp switch 2 judged from lighting switch signal.
LIGHT SW 1ST "ON/OFF"	Displays status (lighting switch 1st position: ON/Others: OFF) of lighting switch judged from lighting switch signal.
AUTO LIGHT SW "ON/OFF"	Displays status of the lighting switch as judged from the lighting switch signal. (AUTO position: ON/Other than AUTO position: OFF)
PASSING SW "ON/OFF"	Displays status (flash-to-pass switch: ON/Others: OFF) of flash-to-pass switch judged from lighting switch signal.
FR FOG SW "ON/OFF"	Displays status (front fog lamp switch: ON/Others: OFF) of front fog lamp switch judged from lighting switch signal.
DOOR SW-DR "ON/OFF"	Displays status of the driver door as judged from the driver door switch signal. (Door is open: ON/Door is closed: OFF)
DOOR SW-AS "ON/OFF"	Displays status of the passenger door as judged from the passenger door switch signal. (Door is open: ON/Door is closed: OFF)
DOOR SW-RR "ON/OFF"	Displays status of the rear door as judged from the rear door switch (RH) signal. (Door is open: ON/Door is closed: OFF)
DOOR SW-RL "ON/OFF"	Displays status of the rear door as judged from the rear door switch (LH) signal. (Door is open: ON/Door is closed: OFF)
BACK DOOR SW "ON/OFF"	Not used.
TURN SIGNAL R "ON/OFF"	Displays status (Turn right: ON/Others: OFF) as judged from lighting switch signal.
TURN SIGNAL L "ON/OFF"	Displays status (Turn left: ON/Others: OFF) as judged from lighting switch signal.
CARGO LAMP SW "ON/OFF"	Displays status of cargo lamp.
OPTICAL SENSOR [0 - 5V]	Displays "ambient light (close to 5V when dark/close to 0V when light)" judged from optical sensor signal.

## ACTIVE TEST

### Operation Procedure

1. Touch "HEAD LAMP" on "SELECT TEST ITEM" screen.
2. Touch "ACTIVE TEST" on "SELECT DIAG MODE" screen.
3. Touch item to be tested and check operation of the selected item.
4. During the operation check, touching "BACK" deactivates the operation.

### Display Item List

Test item	Description
TAIL LAMP	Allows tail lamp relay to operate by switching ON-OFF.
HEAD LAMP	Allows headlamp relay (HI, LO) to operate by switching ON-OFF.
FR FOG LAMP	Allows fog lamp relay to operate by switching ON-OFF.
CARGO LAMP	Allows cargo lamp to operate by switching ON-OFF.

## SELF-DIAGNOSTIC RESULTS

### Operation Procedure

1. Touch "BCM" on "SELECT TEST ITEM" screen.
2. Touch "SELF-DIAG RESULTS" on "SELECT DIAG MODE" screen.
3. Self-diagnostic results are displayed.

### Display Item List

Monitored item	CONSULT-II display	Description
CAN communication	CAN communication [U1000]	Malfunction is detected in CAN communication.
CAN communication system	CAN communication system 1 to 6 [U1000]	Malfunction is detected in CAN system.

# AUTO LIGHT SYSTEM

## CONSULT-II Function (IPDM E/R)

EKS00AA5

CONSULT-II can display each diagnostic item using the diagnostic test modes shown following.

IPDM E/R diagnostic mode	Description
SELF-DIAG RESULTS	Displays IPDM E/R self-diagnosis results.
DATA MONITOR	Displays IPDM E/R input/output data in real time.
CAN DIAG SUPPORT MNTR	The result of transmit/receive diagnosis of CAN communication can be read.
ACTIVE TEST	Operation of electrical loads can be checked by sending drive signal to them.

### CONSULT-II OPERATION

**CAUTION:**

If CONSULT-II is used with no connection of CONSULT-II CONVERTER, malfunctions might be detected in self-diagnosis depending on control unit which carries out CAN communication.

1. With the ignition switch OFF, connect CONSULT-II and CONSULT-II CONVERTER to the data link connector, then turn the ignition switch ON.

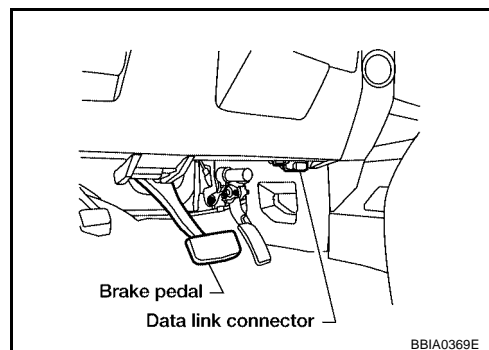

2. Touch "START (NISSAN BASED VHCL)".

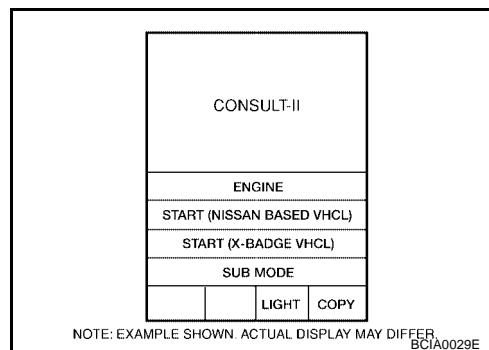

3. Touch "IPDM E/R" on "SELECT SYSTEM" screen. If "IPDM E/R" is not displayed, refer to [GI-38, "CONSULT-II Data Link Connector \(DLC\) Circuit"](#).

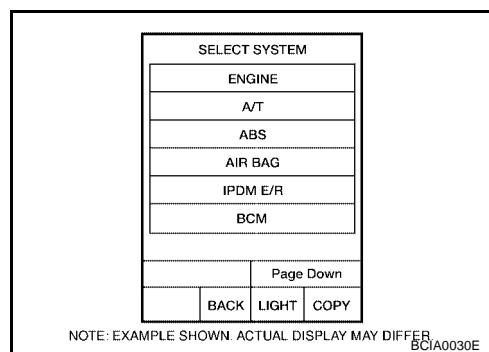

A  
B  
C  
D  
E  
F  
G  
H  
I  
J  
LT  
L  
M

# AUTO LIGHT SYSTEM

- Select the desired part to be diagnosed on the "SELECT DIAG MODE" screen.

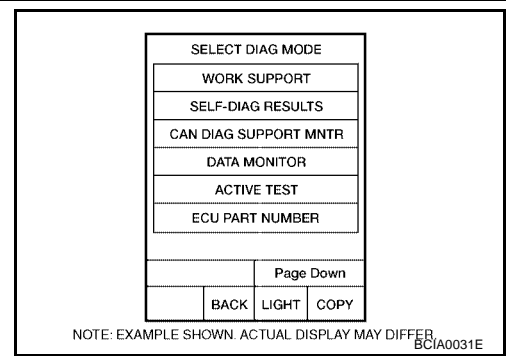

## DATA MONITOR

### Operation Procedure

- Touch "DATA MONITOR" on "SELECT DIAG MODE" screen.
- Touch "ALL SIGNALS", "MAIN SIGNALS" or "SELECTION FROM MENU" on the "SELECT MONITOR ITEM" screen.

ALL SIGNALS	All items will be monitored.
MAIN SIGNALS	Monitor the predetermined item.
SELECTION FROM MENU	Select any item for monitoring.

- Touch "START".
- Touch the required monitoring item on "SELECT ITEM MENU". In "ALL SIGNALS", all items are monitored. In "MAIN SIGNALS", predetermined items are monitored.
- Touch "RECORD" while monitoring to record the status of the item being monitored. To stop recording, touch "STOP".

### All Items, Main Items, Select Item Menu

Item name	CONSULT-II screen display	Display or unit	Monitor item selection			Description
			ALL SIGNALS	MAIN SIGNALS	SELECTION FROM MENU	
Parking, license plate and tail lamps request	TAIL&CLR REQ	ON/OFF	×	×	×	Signal status input from BCM
Headlamp low beam request	HL LO REQ	ON/OFF	×	×	×	Signal status input from BCM
Headlamp high beam request	HL HI REQ	ON/OFF	×	×	×	Signal status input from BCM
Front fog lamps request	FR FOG REQ	ON/OFF	×	×	×	Signal status input from BCM

#### NOTE:

Perform monitoring of IPDM E/R data with the ignition switch ON. When the ignition switch is at ACC, the display may not be correct.

## ACTIVE TEST

### Operation Procedure

- Touch "ACTIVE TEST" on "SELECT DIAG MODE" screen.
- Touch item to be tested, and check operation.
- Touch "START".
- Touch "STOP" while testing to stop the operation.

Test item	CONSULT-II screen display	Description
Tail lamp relay output	TAIL LAMP	Allows tail lamp relay to operate by switching operation ON-OFF at your option.

# AUTO LIGHT SYSTEM

Test item	CONSULT-II screen display	Description
Headlamp relay (HI, LO) output	LAMPS	Allows headlamp relay (HI, LO) to operate by switching operation (OFF, HI, LO) at your option (Headlamp high beam repeats ON-OFF every 1 second).
Front fog lamp relay output		Allows fog lamp relay to operate by switching operation ON-OFF at your option.

## Trouble Diagnosis Chart by Symptom

EKS00AA6

Trouble phenomenon	Malfunction system and reference
<ul style="list-style-type: none"> <li>● Parking lamps and headlamps will not illuminate when outside of the vehicle becomes dark. (Lighting switch 1st position and 2nd position operate normally.)</li> <li>● Parking lamps and headlamp will not go out when outside of the vehicle becomes light. (Lighting switch 1st position and 2nd position operate normally.)</li> <li>● Headlamps go out when outside of the vehicle becomes light, but parking lamps stay on.</li> </ul>	<ul style="list-style-type: none"> <li>● Refer to <a href="#">LT-57, "WORK SUPPORT"</a> .</li> <li>● Refer to <a href="#">LT-61, "Lighting Switch Inspection"</a> .</li> <li>● Refer to <a href="#">LT-62, "Optical Sensor System Inspection"</a> .</li> </ul> If above systems are normal, replace BCM. Refer to <a href="#">BCS-19, "Removal and Installation of BCM"</a> .
Parking lamps illuminate when outside of the vehicle becomes dark, but headlamps stay off. (Lighting switch 1st position and 2nd position operate normally.)	<ul style="list-style-type: none"> <li>● Refer to <a href="#">LT-57, "WORK SUPPORT"</a> .</li> <li>● Refer to <a href="#">LT-62, "Optical Sensor System Inspection"</a> .</li> </ul> If above systems are normal, replace BCM. Refer to <a href="#">BCS-19, "Removal and Installation of BCM"</a> .
Auto light adjustment system will not operate. (Lighting switch AUTO, 1st position and 2nd position operate normally.)	<ul style="list-style-type: none"> <li>● Refer to <a href="#">LT-62, "Optical Sensor System Inspection"</a> .</li> </ul> If above system is normal, replace BCM. Refer to <a href="#">BCS-19, "Removal and Installation of BCM"</a> .
Auto light adjustment system will not operate.	<ul style="list-style-type: none"> <li>● CAN communication line to BCM inspection. Refer to <a href="#">BCS-13, "CAN Communication Inspection Using CONSULT-II (Self-Diagnosis)"</a> .</li> </ul>
Shut off delay feature will not operate.	<ul style="list-style-type: none"> <li>● CAN communication line inspection between BCM and combination meter. Refer to <a href="#">BCS-13, "CAN Communication Inspection Using CONSULT-II (Self-Diagnosis)"</a> .</li> <li>● Refer to <a href="#">BL-35, "Door Switch Check (King Cab)"</a> .</li> </ul> If above system is normal, replace BCM. Refer to <a href="#">BCS-19, "Removal and Installation of BCM"</a> .

## Lighting Switch Inspection

EKS00AA7

### 1. CHECK LIGHTING SWITCH INPUT SIGNAL

Ⓔ With CONSULT-II

Select "BCM" on CONSULT-II. With "HEAD LAMP" data monitor, make sure "AUTO LIGHT SW" turns ON-OFF linked with operation of lighting switch.

**When lighting switch is in AUTO position : AUTO LIGHT SW ON**

ⓧ Without CONSULT-II

Refer to [LT-95, "Combination Switch Inspection"](#) .

OK or NG

OK >> Inspection End.

NG >> Check lighting switch. Refer to [LT-95, "Combination Switch Inspection"](#) .

DATA MONITOR	
MONITOR	
AUTO LIGHT SW	ON

SKIA4196E

# AUTO LIGHT SYSTEM

EKS00AA8

## Optical Sensor System Inspection

### 1. CHECK OPTICAL SENSOR INPUT SIGNAL

④ With CONSULT-II

Select "BCM" on CONSULT-II. With "OPTICAL SENSOR" data monitor, check difference in the voltage when the optical sensor is illuminated and not illuminated.

**Illuminated**

**OPTICAL SENSOR : 3.1V or more**

**Not illuminated**

**OPTICAL SENSOR : 0.6V or less**

#### NOTE:

Optical sensor must be completely subjected to work lamp light. If the optical sensor is insufficiently illuminated, the measured value may not satisfy the standard.

⊗ Without CONSULT-II

GO TO 2.

OK or NG

OK >> Inspection End.

NG >> GO TO 2.

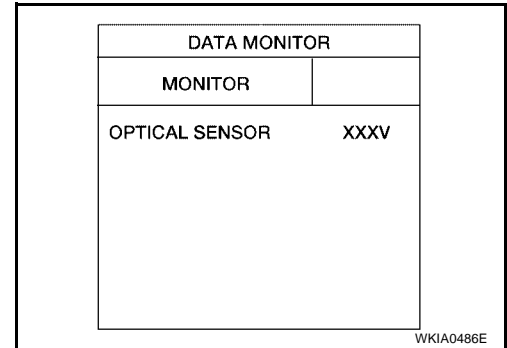

### 2. CHECK OPTICAL SENSOR SIGNAL GROUND CIRCUIT

1. Turn ignition switch OFF.
2. Disconnect BCM connectors and optical sensor connector.
3. Check continuity (open circuit) between BCM harness connector M18 terminal 18 (P) and optical sensor harness connector M402 terminal 3 (P).

**18 (P) - 3 (P) : Continuity should exist.**

4. Check continuity (short circuit) between BCM harness connector M18 terminal 18 (P) and ground.

**18 (P) - Ground : Continuity should not exist.**

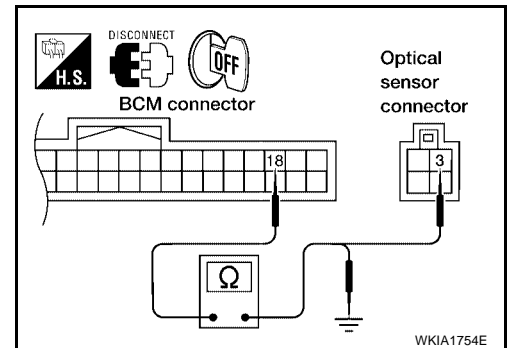

OK or NG

OK >> GO TO 3.

NG >> Repair harness or connector.

### 3. CHECK OPTICAL SENSOR SIGNAL CIRCUIT

1. Check continuity (open circuit) between BCM harness connector M20 terminal 58 (W/R) and optical sensor harness connector M402 terminal 4 (W/R).

**58 (W/R) - 4 (W/R) : Continuity should exist.**

2. Check continuity (short circuit) between BCM harness connector M20 terminal 58 (W/R) and ground.

**58 (W/R) - Ground : Continuity should not exist.**

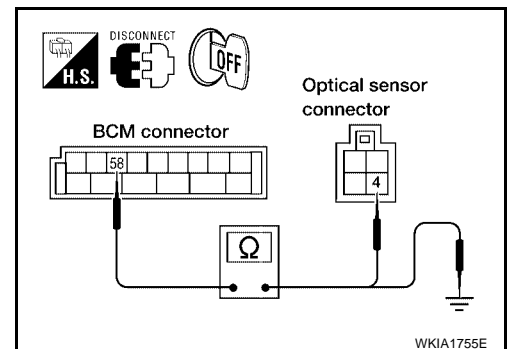

OK or NG

OK >> Replace optical sensor. Refer to [LT-63, "Removal and Installation of Optical Sensor"](#) . Recheck sensor output with CONSULT-II. If NG, replace BCM. Refer to [BCS-19, "Removal and Installation of BCM"](#) .

NG >> Repair harness or connector.

# AUTO LIGHT SYSTEM

## Removal and Installation of Optical Sensor

EKS00AA9

### REMOVAL

1. Remove defroster grille. Refer to [IP-10, "INSTRUMENT PANEL ASSEMBLY"](#) .
2. Disconnect the connector.
3. Turn the optical sensor counterclockwise to remove it from defroster grille.

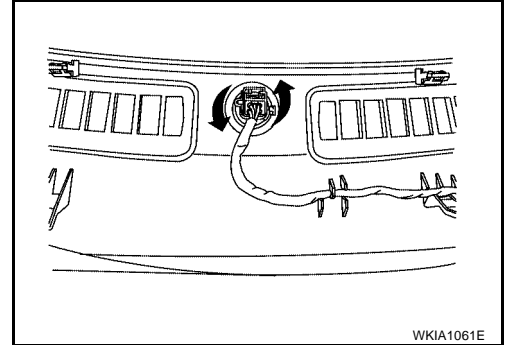

### INSTALLATION

Installation is in the reverse order of removal.

A  
B  
C  
D  
E  
F  
G  
H  
I  
J  
LT  
L  
M

# FRONT FOG LAMP

## FRONT FOG LAMP

PPF:26150

### Component Parts and Harness Connector Location

EKS00AAA

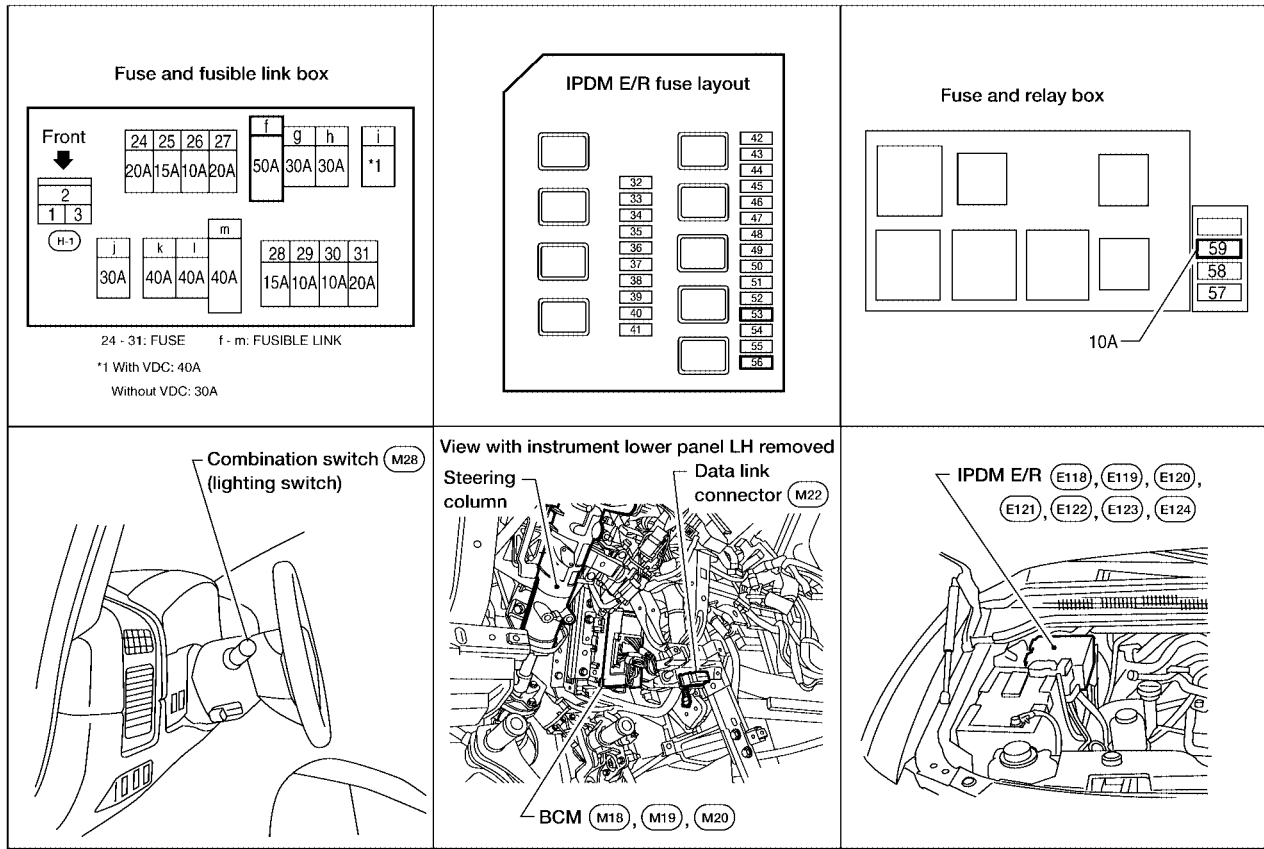

WKIA3582E

## System Description

EKS00AAB

Control of the fog lamps is dependent upon the position of the combination switch (lighting switch). The lighting switch must be in the 2ND position or AUTO position (LOW beam is ON) for front fog lamp operation. When the lighting switch is placed in the fog lamp position, the BCM (body control module) receives input signal requesting the fog lamps to illuminate. When the headlamps are illuminated, this input signal is communicated to the IPDM E/R (intelligent power distribution module engine room) across the CAN communication lines. The CPU (central processing unit) of the IPDM E/R controls the front fog lamp relay coil. When activated, this relay directs power to the front fog lamps.

## OUTLINE

Power is supplied at all times

- to ignition relay, located in the IPDM E/R, and
- to front fog lamp relay, located in the IPDM E/R, and
- through 20A fuse (No. 53, located in the IPDM E/R)
- to CPU in the IPDM E/R, and
- through 50A fusible link (letter f, located in the fuse and fusible link box)
- to BCM terminal 70.

When the ignition switch is in ON or START position, power is supplied

- to ignition relay, located in the IPDM E/R, and
- through 10A fuse (No. 59, located in the fuse and relay box)
- to BCM terminal 38.

Ground is supplied

- to BCM terminal 67
- through grounds M57, M61 and M79, and
- to IPDM E/R terminals 38 and 59



# FRONT FOG LAMP

- through grounds E9, E15 and E24.

## FOG LAMP OPERATION

The fog lamp switch is built into the combination switch. The lighting switch must be in the 2ND position or AUTO position (LOW beam is ON) and the fog lamp switch must be ON for fog lamp operation.

With the fog lamp switch in the ON position, the CPU of the IPDM E/R grounds the coil side of the fog lamp relay. The fog lamp relay then directs power

- through 20A fuse (No. 56, located in the IPDM E/R)
- through IPDM E/R terminal 50
- to front fog lamp LH terminal +, and
- through IPDM E/R terminal 51
- to front fog lamp RH terminal +.

Ground is supplied

- to front fog lamp LH and RH terminal –
- through grounds E9, E15 and E24.

With power and ground supplied, the front fog lamps illuminate.

## COMBINATION SWITCH READING FUNCTION

Refer to [LT-93, "Combination Switch Reading Function"](#) .

## EXTERIOR LAMP BATTERY SAVER CONTROL

When the combination switch (lighting switch) is in the 2ND position (ON), the fog lamp switch is ON, and the ignition switch is turned from ON or ACC to OFF, the battery saver control feature is activated.

Under this condition, the fog lamps (and headlamps) remain illuminated for 5 minutes, then the fog lamps (and headlamps) are turned off.

Exterior lamp battery saver control mode can be changed by the function setting of CONSULT-II.

## CAN Communication System Description

EKS00AAC

Refer to [LAN-7, "CAN COMMUNICATION"](#) .

A

B

C

D

E

F

G

H

I

J

LT

L

M

# FRONT FOG LAMP

## Wiring Diagram — F/FOG —

EKS00AAD

LT-F/FOG-01

— : DATA LINE

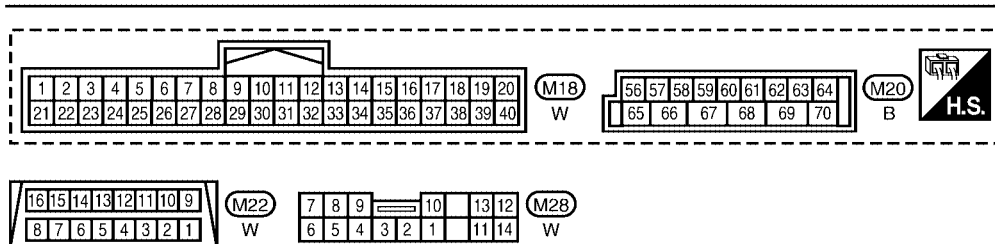
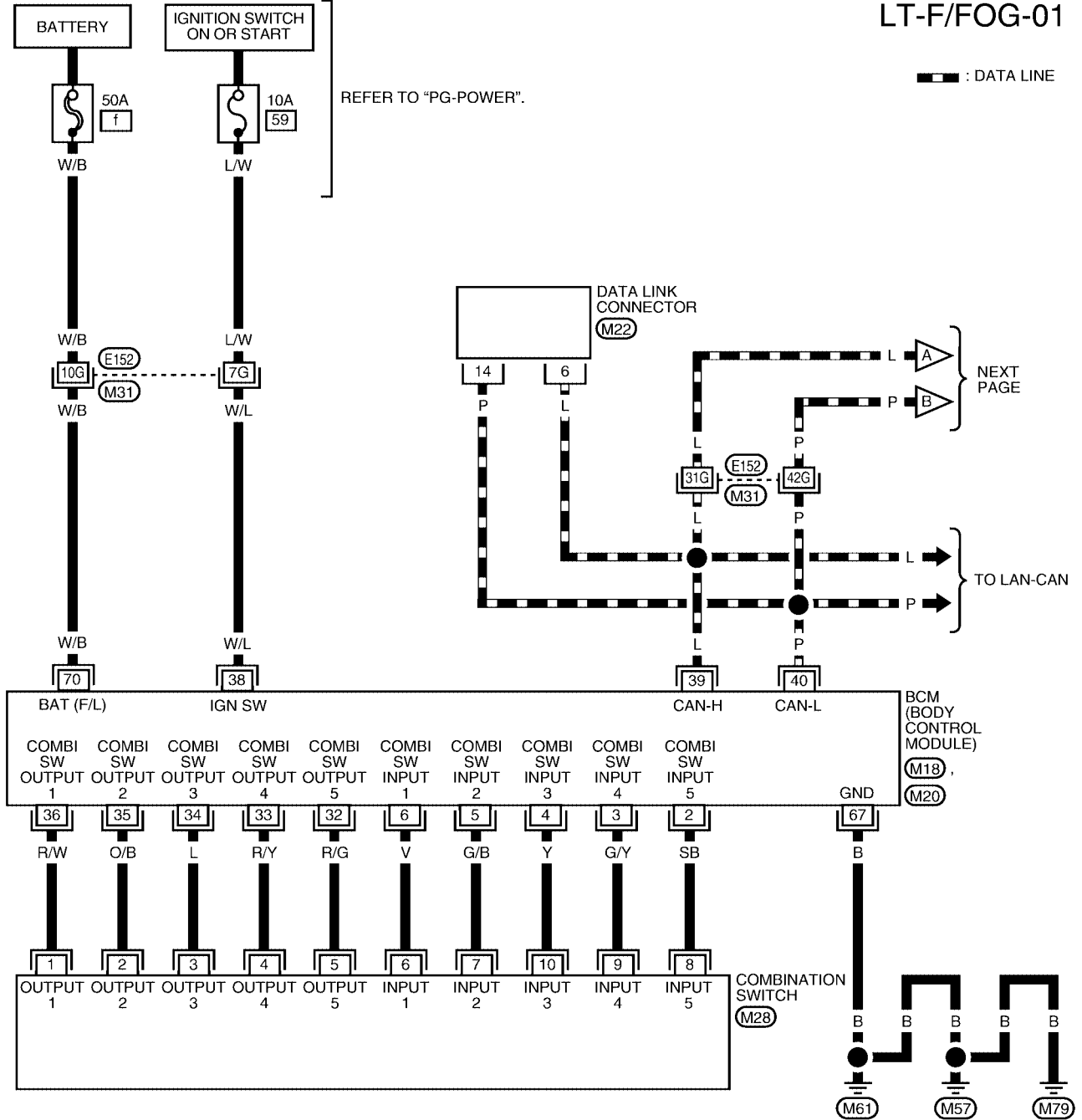

REFER TO THE FOLLOWING.

(M31) - SUPER MULTIPLE JUNCTION (SMJ)

WKWA2406E

# FRONT FOG LAMP

LT-F/FOG-02

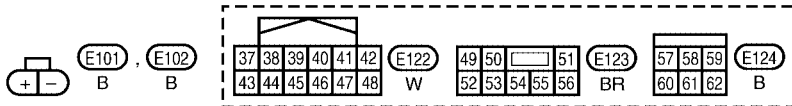
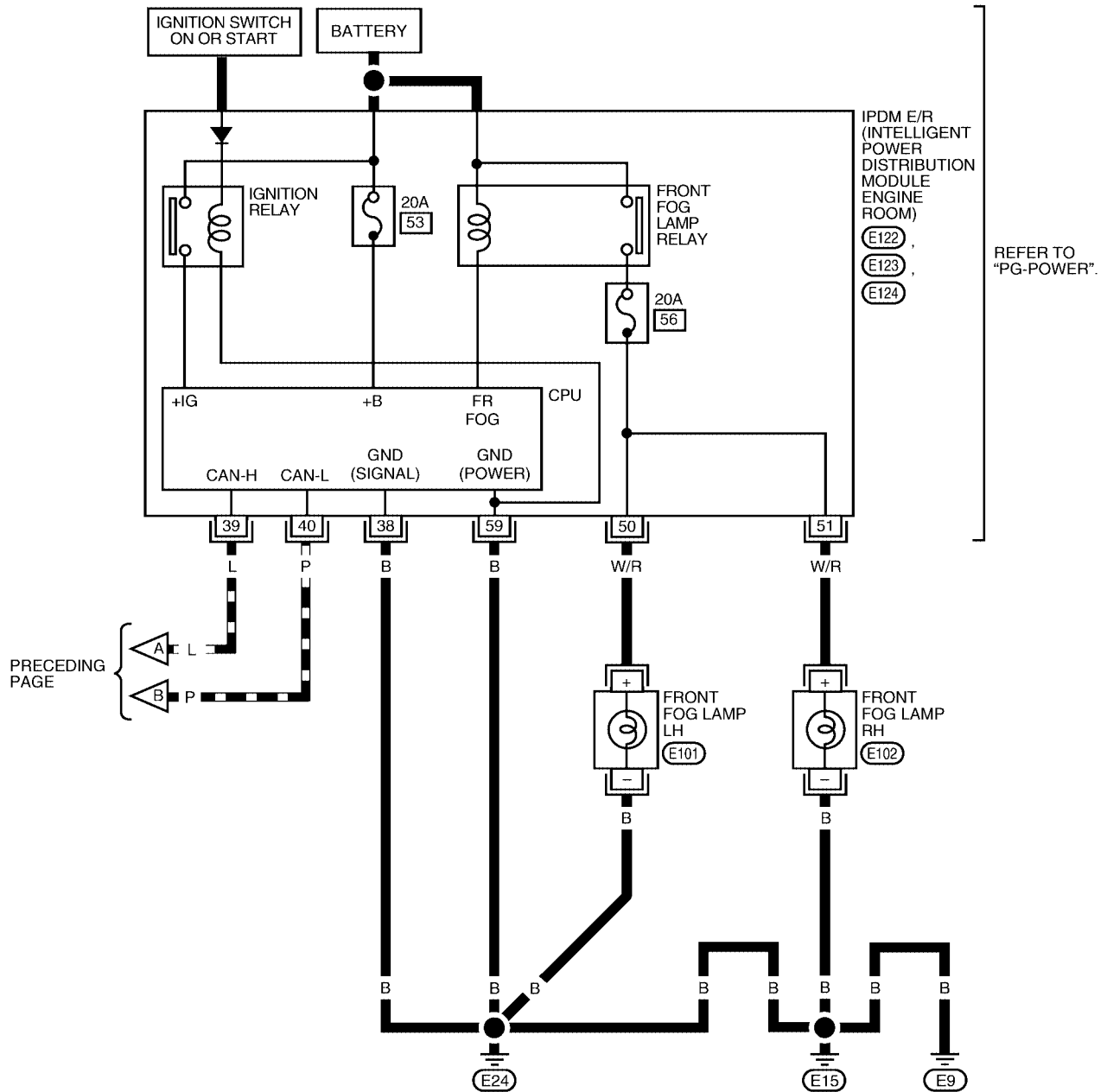





WKWA2407E

# FRONT FOG LAMP

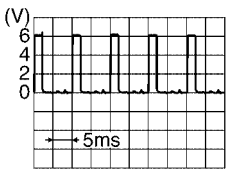
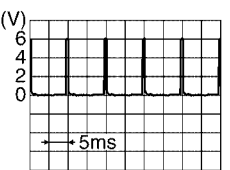
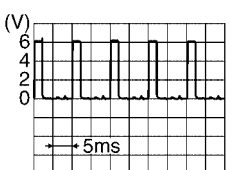
## Terminals and Reference Values for BCM

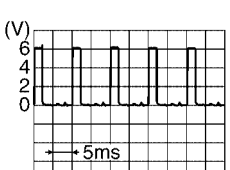
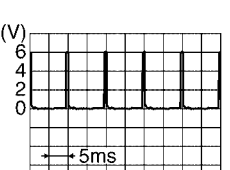
EKS00AAE

Terminal No.	Wire color	Signal name	Measuring condition		Reference value (Approx.)
			Ignition switch	Operation or condition	
2	SB	Combination switch input 5	ON	Lighting, turn, wiper OFF Wiper dial position 4	 <p style="text-align: right;">SKIA5291E</p>
3	G/Y	Combination switch input 4	ON	Lighting, turn, wiper OFF Wiper dial position 4	 <p style="text-align: right;">SKIA5292E</p>
4	Y	Combination switch input 3	ON	Lighting, turn, wiper OFF Wiper dial position 4	 <p style="text-align: right;">SKIA5291E</p>
5	G/B	Combination switch input 2	ON	Lighting, turn, wiper OFF Wiper dial position 4	 <p style="text-align: right;">SKIA5292E</p>
6	V	Combination switch input 1			
32	R/G	Combination switch output 5	ON	Lighting, turn, wiper OFF Wiper dial position 4	 <p style="text-align: right;">SKIA5291E</p>
33	R/Y	Combination switch output 4	ON	Lighting, turn, wiper OFF Wiper dial position 4	 <p style="text-align: right;">SKIA5292E</p>
34	L	Combination switch output 3	ON	Lighting, turn, wiper OFF Wiper dial position 4	 <p style="text-align: right;">SKIA5291E</p>

# FRONT FOG LAMP

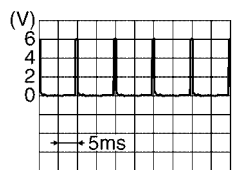
Terminal No.	Wire color	Signal name	Measuring condition		Reference value (Approx.)
			Ignition switch	Operation or condition	
35	O/B	Combination switch output 2	ON	Lighting, turn, wiper OFF Wiper dial position 4	
36	R/W	Combination switch output 1			
38	W/L	Ignition switch (ON)	ON	—	Battery voltage
39	L	CAN-H	—	—	—
40	P	CAN-L	—	—	—
67	B	Ground	ON	—	0V
70	W/B	Battery power supply (fusible link)	OFF	—	Battery voltage

## Terminals and Reference Values for IPDM E/R

EKS00AAF

Terminal No.	Wire color	Signal name	Measuring condition		Reference value (Approx.)	
			Ignition switch	Operation or condition		
38	B	Ground	ON	—	0V	
39	L	CAN-H	—	—	—	
40	P	CAN-L	—	—	—	
50	W/R	Front fog lamp (LH)	ON	Lighting switch must be in the 2ND position or AUTO position (LOW beam is ON) and the front fog lamp switch must be ON	OFF	0V
					ON	Battery voltage
51	W/R	Front fog lamp (RH)	ON	Lighting switch must be in the 2ND position or AUTO position (LOW beam is ON) and the front fog lamp switch must be ON	OFF	0V
					ON	Battery voltage
59	B	Ground	ON	—	0V	

## How to Proceed With Trouble Diagnosis

EKS00AAG

1. Confirm the symptom or customer complaint.
2. Understand operation description and function description. Refer to [LT-64, "System Description"](#) .
3. Perform the Preliminary Check. Refer to [LT-70, "Preliminary Check"](#) .
4. Check symptom and repair or replace the cause of malfunction.
5. Does the front fog lamp operate normally? If YES: GO TO 6. If NO: GO TO 4.
6. Inspection End.

# FRONT FOG LAMP

EKS00AAH

## Preliminary Check CHECK BCM CONFIGURATION

### 1. CHECK BCM CONFIGURATION

Confirm BCM configuration for "FR FOG LAMP" is set to "WITH". Refer to [BCS-13, "READ CONFIGURATION PROCEDURE"](#).

OK or NG

- OK >> Continue preliminary check. Refer to [LT-70, "CHECK POWER SUPPLY AND GROUND CIRCUIT"](#).
- NG >> Change BCM configuration for "FR FOG LAMP" to "WITH". Refer to [BCS-16, "WRITE CONFIGURATION PROCEDURE"](#).

## CHECK POWER SUPPLY AND GROUND CIRCUIT

### 1. CHECK FUSES OR FUSIBLE LINK

Check for blown fuses or fusible link.

Unit	Power source	Fuse No.
BCM	Battery	f
	Ignition switch ON or START position	59
IPDM E/R	Battery	53
	Battery (Fog lamps ON)	56

Refer to [LT-66, "Wiring Diagram — F/FOG —"](#).

OK or NG

- OK >> GO TO 2.
- NG >> If fuse is blown, be sure to eliminate cause of malfunction before installing new fuse. Refer to [PG-4, "POWER SUPPLY ROUTING CIRCUIT"](#).

### 2. CHECK POWER SUPPLY CIRCUIT

1. Disconnect BCM connectors.
2. Check voltage between BCM harness connector and ground.

Terminals		(-)	Ignition switch position		
(+)			OFF	ACC	ON
Connector	Terminal (Wire color)	Ground	0V	0V	Battery voltage
M18	38 (W/L)		Battery voltage	Battery voltage	Battery voltage
M20	70 (W/B)				

OK or NG

- OK >> GO TO 3.
- NG >> Check harness for open between BCM and fuse.

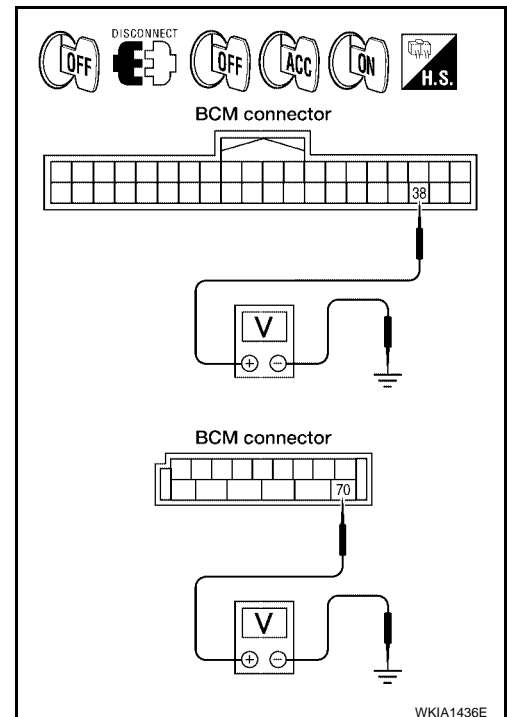

# FRONT FOG LAMP

## 3. CHECK GROUND CIRCUIT

Check continuity between BCM harness connector and ground.

Connector	Terminals		Continuity
	Terminal (Wire color)		
M20	67 (B)	Ground	Yes

OK or NG

- OK >> Inspection End.
- NG >> Check ground circuit harness.

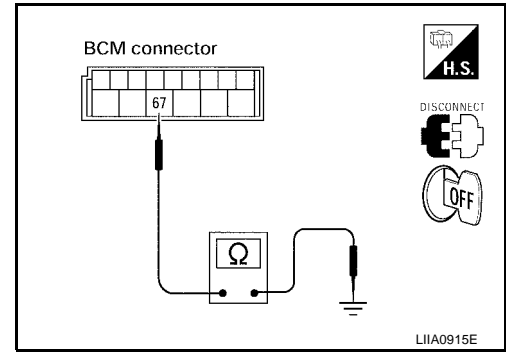

EKS00AAI

## CONSULT-II Functions

Refer to [LT-17, "CONSULT-II Function \(BCM\)"](#) in HEADLAMP (FOR USA).  
 Refer to [LT-20, "CONSULT-II Function \(IPDM E/R\)"](#) in HEADLAMP (FOR USA).

## Front Fog Lamps Do Not Illuminate (Both Sides)

EKS00AAJ

### 1. CHECK COMBINATION SWITCH INPUT SIGNAL

Select "BCM" on CONSULT-II. With "HEAD LAMP" data monitor, make sure "FR FOG SW" turns ON-OFF linked with operation of lighting switch.

**When lighting switch is in FOG position : FR FOG SW ON**

OK or NG

- OK >> GO TO 2.
- NG >> Check lighting switch. Refer to [LT-95, "Combination Switch Inspection"](#).

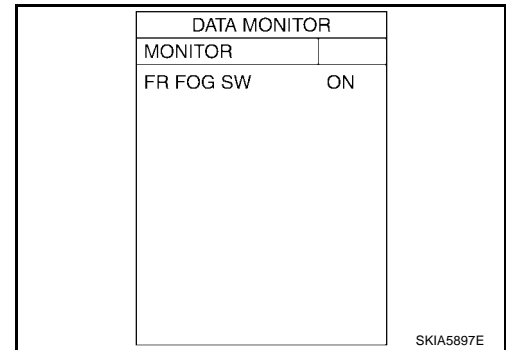

SKIA5897E

### 2. FOG LAMP ACTIVE TEST

- Select "IPDM E/R" on CONSULT-II, and select "ACTIVE TEST" on "SELECT DIAG MODE" screen.
- Select "EXTERNAL LAMPS" on "SELECT TEST ITEM" screen.
- Touch "FOG" on "ACTIVE TEST" screen.
- Make sure fog lamps operate.

**Fog lamps should operate.**

OK or NG

- OK >> GO TO 3.
- NG >> GO TO 4.

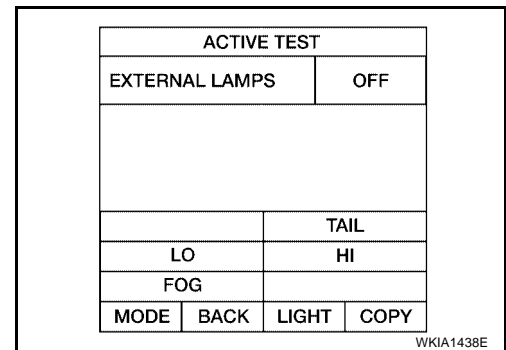

WKIA1438E

# FRONT FOG LAMP

## 3. CHECK IPDM E/R

1. Select "IPDM E/R" on CONSULT-II, and select "DATA MONITOR" on "SELECT DIAG MODE" screen.
2. Make sure "FR FOG REQ" turns ON when lighting switch is in FOG position.

**When lighting switch is in FOG position : FR FOG REQ ON**

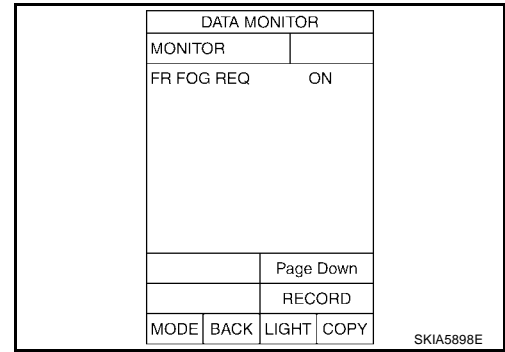

OK or NG

- OK >> Replace IPDM E/R. Refer to [PG-28, "Removal and Installation of IPDM E/R"](#).
- NG >> Replace BCM. Refer to [BCS-19, "Removal and Installation of BCM"](#).

## 4. IPDM E/R INSPECTION

Start auto active test. Refer to [PG-22, "Auto Active Test"](#). When front fog lamp relay is operating, check voltage between left/right front fog lamp connector terminals and ground.

Terminals			Voltage (Approx.)
Front fog lamp (+)		(-)	
Connector	Terminal (wire color)		
LH	E101	+ (W/R)	Ground
RH	E102	+ (W/R)	
			Battery voltage

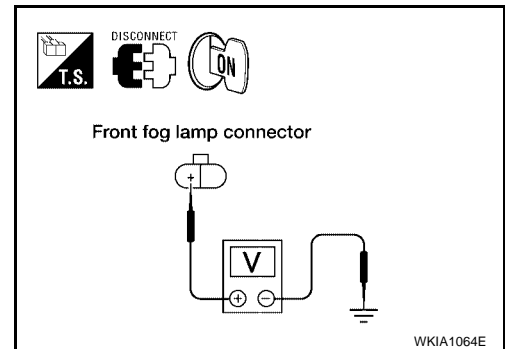

OK or NG

- OK >> Check front fog lamp bulbs and replace as necessary.
- NG >> Replace IPDM E/R. Refer to [PG-28, "Removal and Installation of IPDM E/R"](#).

## Front Fog Lamp Does Not Illuminate (One Side)

EKS00AAK

### 1. BULB INSPECTION

Inspect bulbs of lamps which do not illuminate. Refer to [LT-167, "Exterior Lamp"](#).

OK or NG

- OK >> GO TO 2.
- NG >> Replace lamp bulb. Refer to [LT-74, "Bulb Replacement"](#).

### 2. INSPECTION BETWEEN IPDM E/R AND FRONT FOG LAMPS

1. Disconnect IPDM E/R connector and inoperative front fog lamp connector.
2. Check continuity between harness connector terminals of IPDM E/R and harness connector terminal of front fog lamps.

Terminals				Continuity
IPDM E/R		Front fog lamp		
Connector	Terminal (wire color)	Connector	Terminal (wire color)	
E123	50 (W/R)	LH	E101	+ (W/R)
	51 (W/R)	RH	E102	+ (W/R)
				Yes

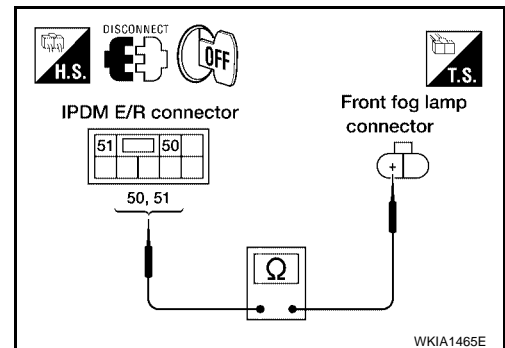

OK or NG

- OK >> Check ground circuit. If OK, replace IPDM E/R. Refer to [PG-28, "Removal and Installation of IPDM E/R"](#). If NG, repair harness or connector.
- NG >> Check for short circuits and open circuits in harness between IPDM E/R and front fog lamps.



# FRONT FOG LAMP

## Aiming Adjustment

EKS00AAL

The fog lamp is a semi-sealed beam type which uses a replaceable halogen bulb. Before performing aiming adjustment, make sure of the following.

- Keep all tires inflated to correct pressure.
- Place vehicle on level ground.
- See that vehicle is unloaded (except for full levels of coolant, engine oil and fuel, and spare tire, jack, and tools). Have the driver or equivalent weight placed in driver seat.

Adjust aiming in the vertical direction by turning the adjustment screw.

### NOTE:

Access adjustment screw from underneath front bumper. Use a T-3 (3 mm) Torx® bit or a 3 mm allen wrench to adjust. Turn screw clockwise to raise pattern and counterclockwise to lower pattern.

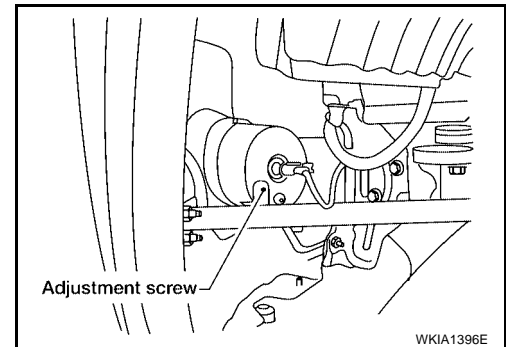

1. Set the distance between the screen and the center of the fog lamp lens as shown.
2. Turn front fog lamps ON.

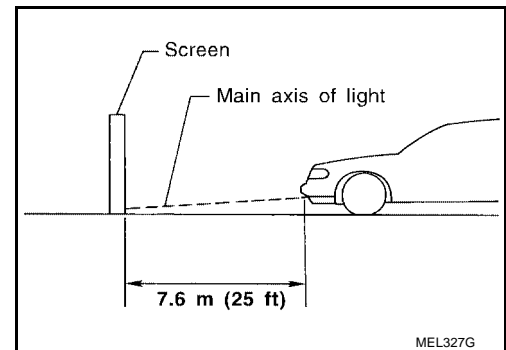

3. Adjust front fog lamps using adjusting screw so that the top edge of the high intensity zone is 100 mm (4 in) below the height of the fog lamp centers as shown.
- When performing adjustment, if necessary, cover the headlamps and opposite fog lamp.

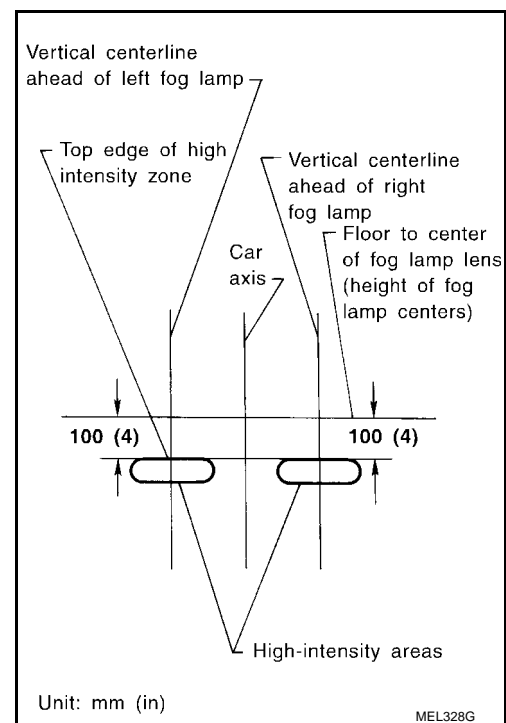

A  
B  
C  
D  
E  
F  
G  
H  
I  
J  
LT  
L  
M

# FRONT FOG LAMP

## Bulb Replacement

EKS00AAM

1. Disconnect electrical connector.
2. Turn the bulb counterclockwise to remove it.

### CAUTION:

- Do not touch the glass of bulb directly by hand. Keep grease and other oily substances away from it. Do not touch bulb by hand while it is lit or right after being turned off. Burning may result.
- Do not leave bulb out of fog lamp reflector for a long time because dust, moisture smoke, etc. may affect the performance of fog lamp. When replacing bulb, be sure to replace it with new one.

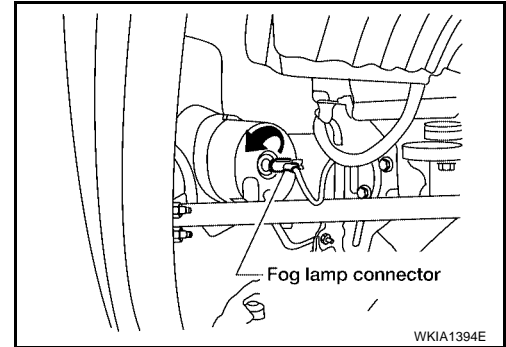

## Removal and Installation

EKS00AAN

The fog lamp is a semi-sealed beam type which uses a replaceable halogen bulb.

### CAUTION:

- Do not leave fog lamp assembly without bulb for a long period of time. Dust, moisture, smoke, etc. entering the fog lamp body may affect the performance. Remove the bulb from the headlamp assembly just before replacement bulb is installed.
  - Grasp only the plastic base when handling the bulb. Never touch the glass envelope. Touching the glass could significantly affect the bulb life and/or fog lamp performance.
1. Position the fender protector aside.
  2. Disconnect electrical connector.
  3. Remove nut and pull fog lamp out of front fascia.

Installation is in the reverse order of removal.

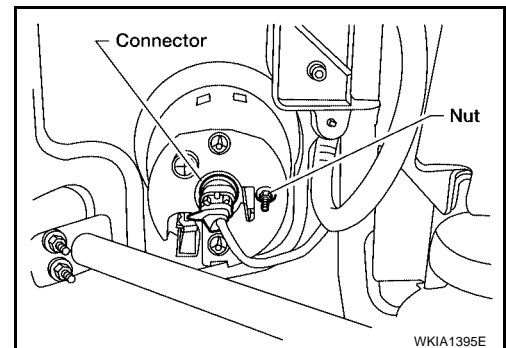

# TURN SIGNAL AND HAZARD WARNING LAMPS

PF2:26120

EKS00AAO

## TURN SIGNAL AND HAZARD WARNING LAMPS

### Component Parts and Harness Connector Location

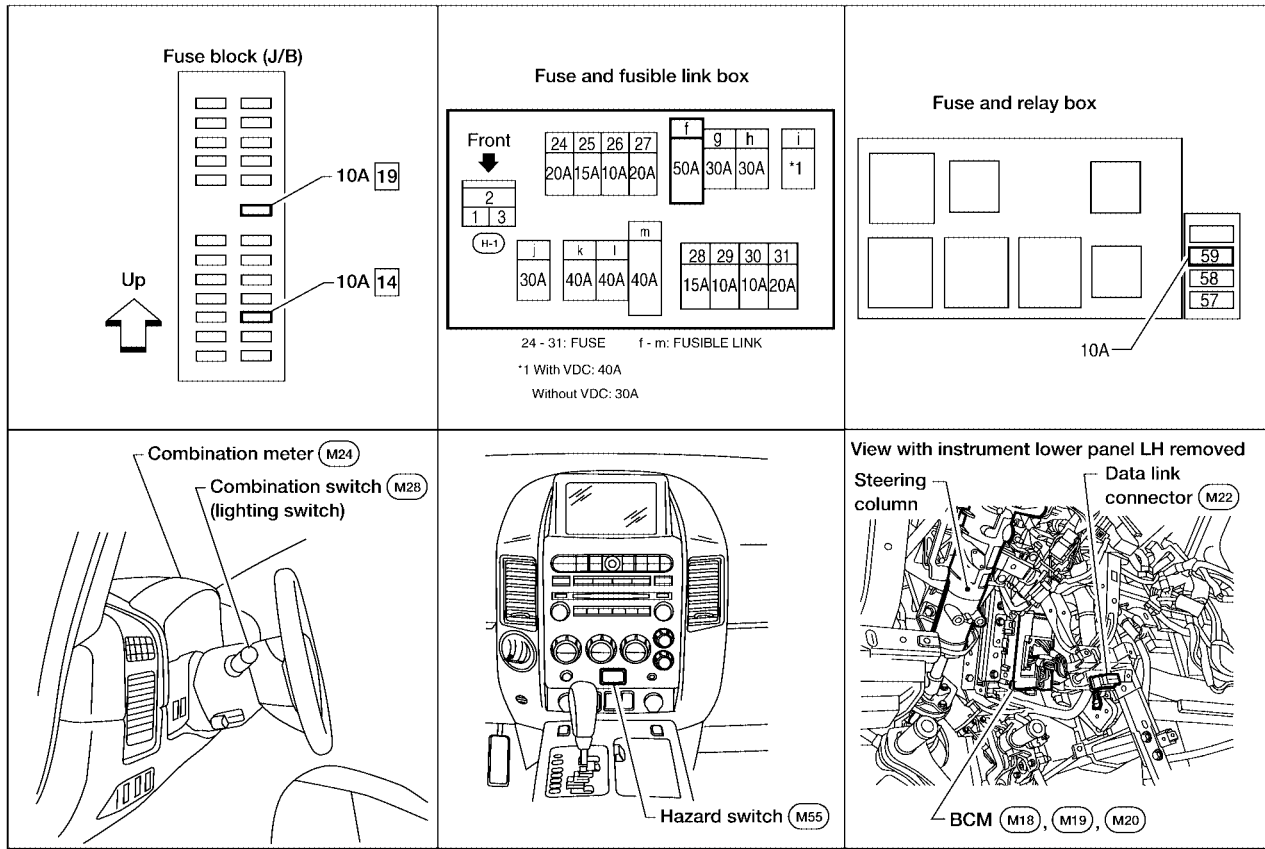

WKIA3583E

EKS00AAP

### System Description OUTLINE

Power is supplied at all times

- through 50A fusible link (letter f , located in the fuse and fusible link box)
- to BCM (body control module) terminal 70, and
- through 10A fuse [No. 19, located in the fuse block (J/B)]
- to combination meter terminal 8.

### TURN SIGNAL OPERATION

When the ignition switch is in the ON or START position, power is supplied

- through 10A fuse (No. 59, located in the fuse and relay box)
- to BCM terminal 38, and
- through 10A fuse [No. 14, located in the fuse block (J/B)]
- to combination meter terminal 24.

Ground is supplied

- to BCM terminal 67 and
- to combination meter terminal 17
- through grounds M57, M61 and M79.

### LH Turn

When the turn signal switch is moved to the left position, the BCM, interpreting it as turn signal is ON, outputs turn signal from BCM terminal 60.

The BCM supplies power

- through BCM terminal 60
- to front combination lamp LH terminal 5

A  
B  
C  
D  
E  
F  
G  
H  
I  
J

LT

L

M

## TURN SIGNAL AND HAZARD WARNING LAMPS

---

- through front combination lamp LH terminal 4
- to grounds E9, E15 and E24, and
- to rear combination lamp LH terminal 8
- through rear combination lamp LH terminal 1
- to grounds E9, E15 and E24.

BCM sends signal to combination meter through CAN communication lines, and turns on turn signal indicator lamp within combination meter.

### RH Turn

When the turn signal switch is moved to the right position, the BCM, interpreting it as turn signal is ON, outputs turn signal from BCM terminal 61.

The BCM supplies power

- through BCM terminal 61
- to front combination lamp RH terminal 5
- through front combination lamp RH terminal 4
- to grounds E9, E15 and E24, and
- to rear combination lamp RH terminal 8
- through rear combination lamp RH terminal 1
- to grounds E9, E15 and E24.

BCM sends signal to combination meter through CAN communication lines, and turns on turn signal indicator lamp within combination meter.

### HAZARD LAMP OPERATION

Power is supplied at all times

- through 50A fusible link (letter **f** , located in the fuse and fusible link box)
- to BCM terminal 70, and
- through 10A fuse [No. 19, located in the fuse block (J/B)]
- to combination meter terminal 8.

Ground is supplied

- to BCM terminal 67 and
- to combination meter terminal 17
- through grounds M57, M61 and M79.

When the hazard switch is depressed, ground is supplied

- to BCM terminal 29
- through hazard switch terminal 4
- through hazard switch terminal 6
- through grounds M57, M61 and M79.

When the hazard switch is depressed, the BCM, interpreting it as turn signal is ON, outputs turn signal from BCM terminals 60 and 61.

The BCM supplies power

- through BCM terminals 60 and 61
- to front combination lamp LH and RH terminal 5
- through front combination lamp LH and RH terminal 4
- to grounds E9, E15 and E24, and
- to rear combination lamp LH and RH terminal 8
- through rear combination lamp LH and RH terminal 1
- to grounds E9, E15 and E24.

BCM sends signal to combination meter through CAN communication lines, and turns on turn signal indicator lamps within combination meter.

### REMOTE KEYLESS ENTRY SYSTEM OPERATION

Power is supplied at all times

# TURN SIGNAL AND HAZARD WARNING LAMPS

- through 50A fusible link (letter f , located in the fuse and fusible link box)
- to BCM terminal 70, and
- through 10A fuse [No. 19, located in the fuse block (J/B)]
- to combination meter terminal 8.

Ground is supplied

- to BCM terminal 67 and
- to combination meter terminal 17
- through grounds M57, M61 and M79.

When the remote keyless entry system is triggered by input from the keyfob, the BCM, interpreting it as turn signal is ON, outputs turn signal from BCM terminals 60 and 61.

The BCM supplies power

- through BCM terminals 60 and 61
- to front combination lamp LH and RH terminal 5
- through front combination lamp LH and RH terminal 4
- to grounds E9, E15 and E24, and
- to rear combination lamp LH and RH terminal 8
- through rear combination lamp LH and RH terminal 1
- to grounds E9, E15 and E24.

BCM sends signal to combination meter through CAN communication lines, and turns on turn signal indicator lamps within combination meter.

With power and input supplied, the BCM controls the flashing of the hazard warning lamps when keyfob is used to activate the remote keyless entry system.

## COMBINATION SWITCH READING FUNCTION

Refer to [LT-93, "Combination Switch Reading Function"](#) .

## CAN Communication System Description

Refer to [LAN-7, "CAN COMMUNICATION"](#) .

A

B

C

D

E

F

G

H

I

J

LT

L

M

EKS00AAQ

# TURN SIGNAL AND HAZARD WARNING LAMPS

## Wiring Diagram — TURN —

EKS00AAR

LT-TURN-01

— : DATA LINE

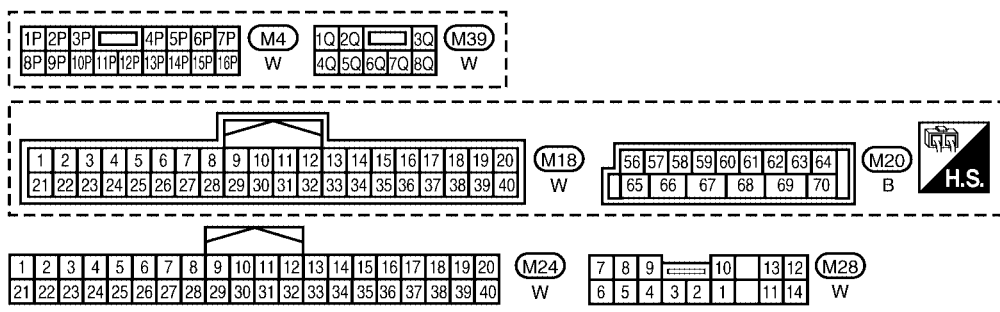
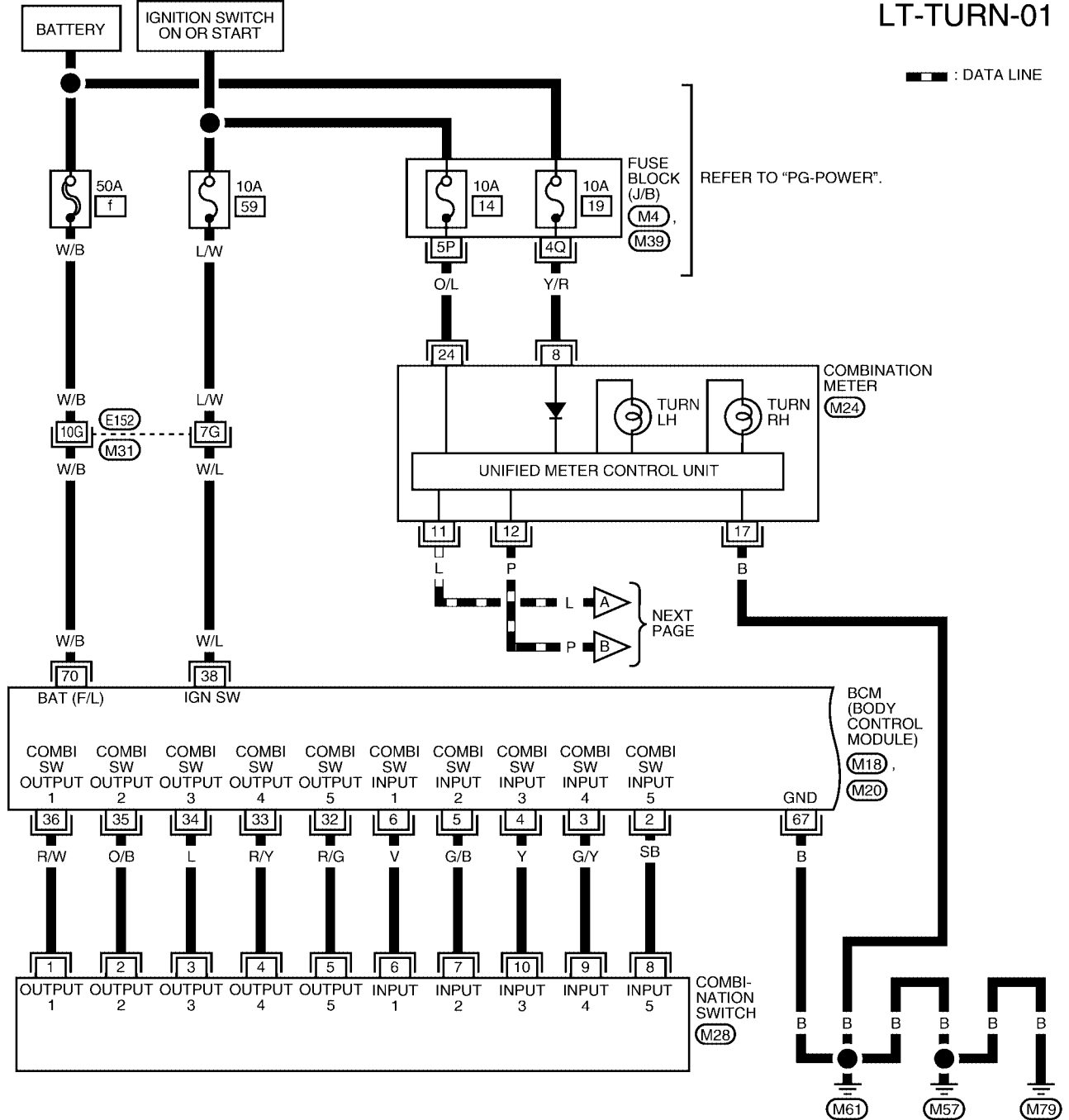

REFER TO THE FOLLOWING.  
(M31) - SUPER MULTIPLE JUNCTION (SMJ)

WKWA2408E

# TURN SIGNAL AND HAZARD WARNING LAMPS

LT-TURN-02

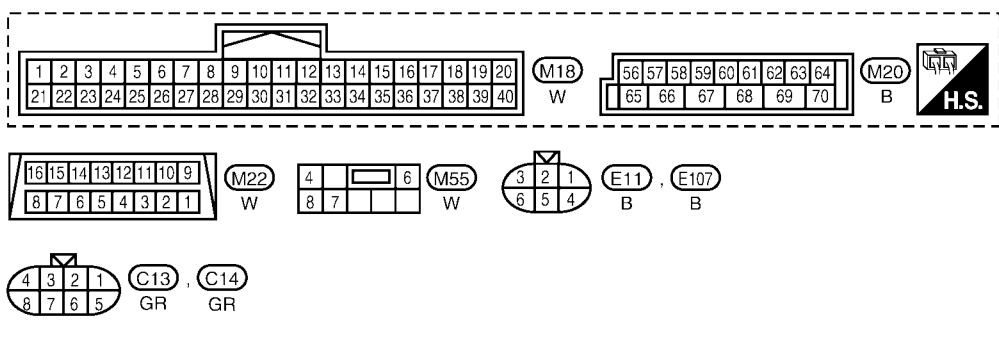
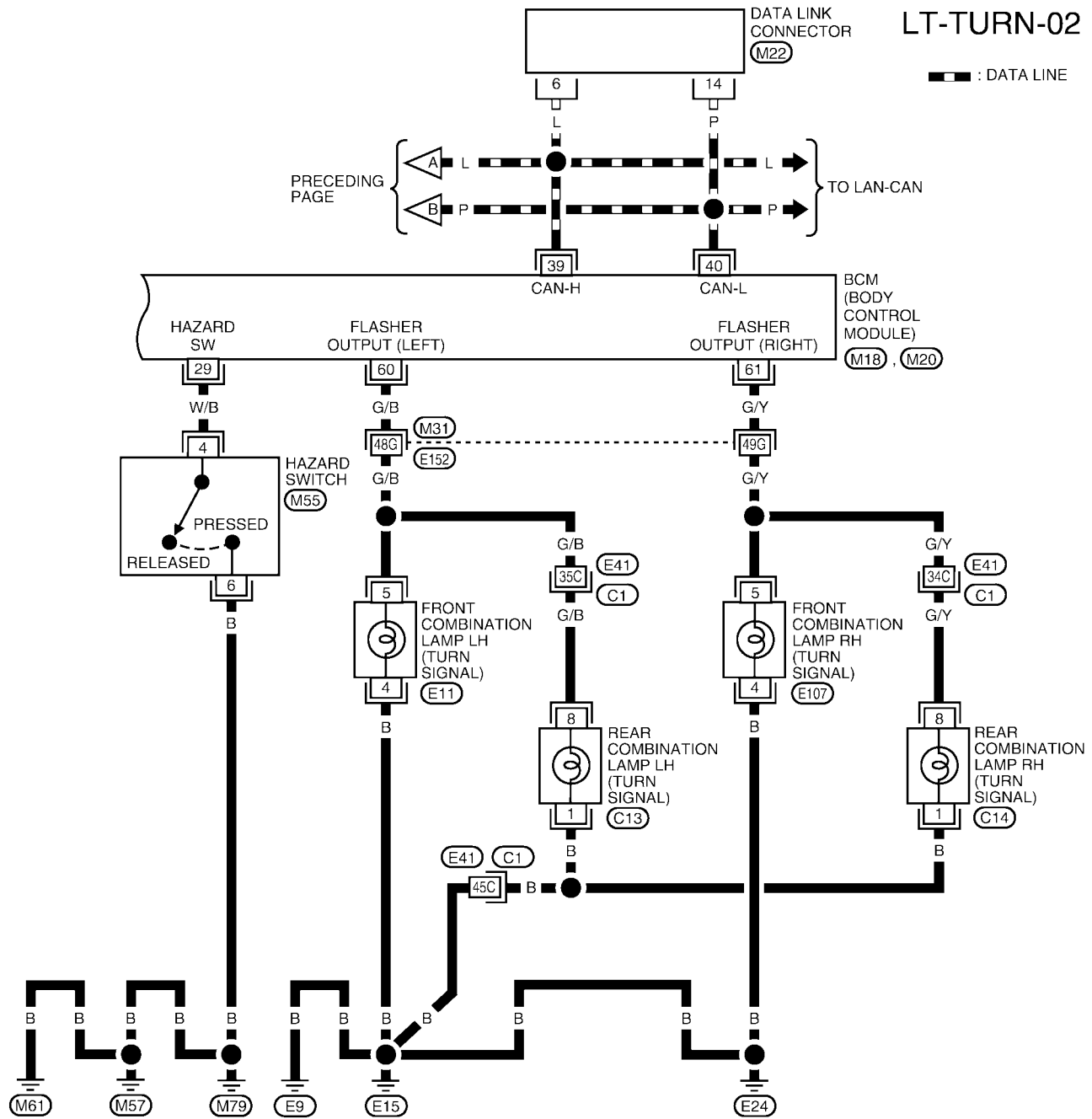





WKWA2446E

# TURN SIGNAL AND HAZARD WARNING LAMPS

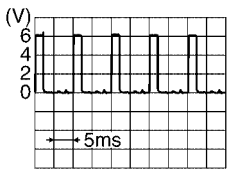
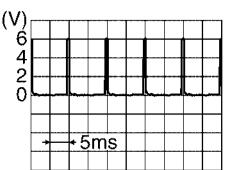
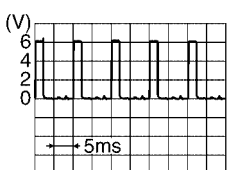
## Terminals and Reference Values for BCM

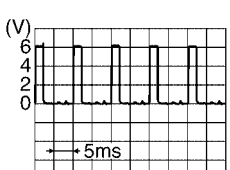
EKS00AAS

Terminal No.	Wire color	Signal name	Measuring condition		Reference value (Approx.)				
			Ignition switch	Operation or condition					
2	SB	Combination switch input 5	ON	Lighting, turn, wiper OFF Wiper dial position 4	 <p style="text-align: right;">SKIA5291E</p>				
3	G/Y	Combination switch input 4	ON	Lighting, turn, wiper OFF Wiper dial position 4	 <p style="text-align: right;">SKIA5292E</p>				
4	Y	Combination switch input 3	ON	Lighting, turn, wiper OFF Wiper dial position 4	 <p style="text-align: right;">SKIA5291E</p>				
5	G/B	Combination switch input 2	ON	Lighting, turn, wiper OFF Wiper dial position 4	 <p style="text-align: right;">SKIA5292E</p>				
6	V	Combination switch input 1							
29	W/B	Hazard switch signal	OFF	Hazard switch	<table border="1" style="width: 100%; border-collapse: collapse;"> <tr> <td style="width: 50%; text-align: center;">ON</td> <td style="text-align: center;">0V</td> </tr> <tr> <td style="width: 50%; text-align: center;">OFF</td> <td style="text-align: center;">5V</td> </tr> </table>	ON	0V	OFF	5V
ON	0V								
OFF	5V								
32	R/G	Combination switch output 5	ON	Lighting, turn, wiper OFF Wiper dial position 4	 <p style="text-align: right;">SKIA5291E</p>				
33	R/Y	Combination switch output 4	ON	Lighting, turn, wiper OFF Wiper dial position 4	 <p style="text-align: right;">SKIA5292E</p>				

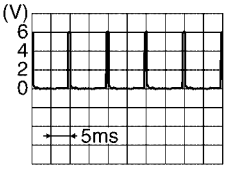
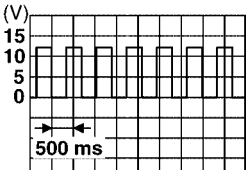
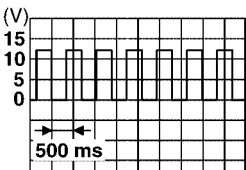

# TURN SIGNAL AND HAZARD WARNING LAMPS

Terminal No.	Wire color	Signal name	Measuring condition		Reference value (Approx.)
			Ignition switch	Operation or condition	
34	L	Combination switch output 3	ON	Lighting, turn, wiper OFF Wiper dial position 4	 SKIA5291E
35	O/B	Combination switch output 2	ON	Lighting, turn, wiper OFF Wiper dial position 4	 SKIA5292E
36	R/W	Combination switch output 1			
38	W/L	Ignition switch (ON)	ON	—	Battery voltage
39	L	CAN-H	—	—	—
40	P	CAN-L	—	—	—
60	G/B	Turn signal (left)	ON	Combination switch Turn left ON	 SKIA3009J
61	G/Y	Turn signal (right)	ON	Combination switch Turn right ON	 SKIA3009J
67	B	Ground	ON	—	0V
70	W/B	Battery power supply	OFF	—	Battery voltage

## How to Proceed With Trouble Diagnosis

EKS00AAT

1. Confirm the symptom or customer complaint.
2. Understand operation description and function description. Refer to [LT-75, "System Description"](#).
3. Perform preliminary check. Refer to [LT-82, "Preliminary Check"](#).
4. Check symptom and repair or replace the cause of malfunction.
5. Do turn signal and hazard warning lamps operate normally? If YES: GO TO 6. If NO: GO TO 4.
6. Inspection End.

# TURN SIGNAL AND HAZARD WARNING LAMPS

EKS00AAU

## Preliminary Check CHECK POWER SUPPLY AND GROUND CIRCUIT

### 1. CHECK FUSES OR FUSIBLE LINK

Check for blown fuses or fusible link.

Unit	Power source	Fuse No.
BCM	Battery	f
	Ignition switch ON or START position	59

Refer to [LT-78, "Wiring Diagram — TURN —"](#) .

OK or NG

OK >> GO TO 2.

NG >> If fuse is blown, be sure to eliminate cause of malfunction before installing new fuse. Refer to [PG-4, "POWER SUPPLY ROUTING CIRCUIT"](#) .

### 2. CHECK POWER SUPPLY CIRCUIT

1. Disconnect BCM connectors.
2. Check voltage between BCM harness connector and ground.

Terminals		(-)	Ignition switch position		
(+)			OFF	ACC	ON
Connector	Terminal (Wire color)	Ground	0V	0V	Battery voltage
M18	38 (W/L)		Battery voltage	Battery voltage	Battery voltage
M20	70 (W/B)				

OK or NG

OK >> GO TO 3.

NG >> Check harness for open between BCM and fuse.

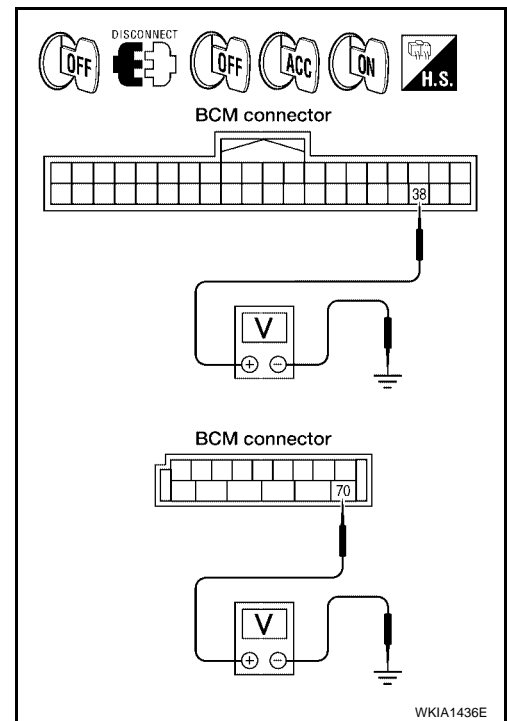

### 3. CHECK GROUND CIRCUIT

Check continuity between BCM harness connector and ground.

Terminals		Continuity
Connector	Terminal (Wire color)	
M20	67 (B)	Ground Yes

OK or NG

OK >> Inspection End.

NG >> Check ground circuit harness.

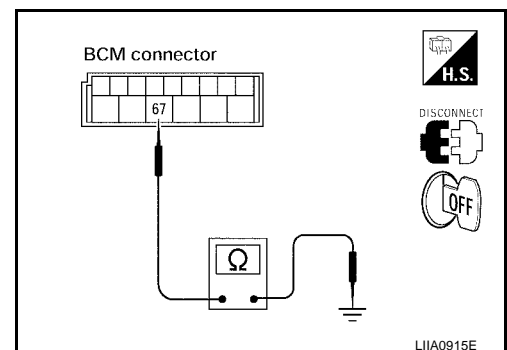

# TURN SIGNAL AND HAZARD WARNING LAMPS

## CONSULT-II Function (BCM)

EKS00AAV

CONSULT-II can display each diagnostic item using the diagnostic test modes shown following.

BCM diagnostic test item	Diagnostic mode	Description
Inspection by part	WORK SUPPORT	Supports inspections and adjustments. Commands are transmitted to the BCM for setting the status suitable for required operation, input/output signals are received from the BCM and received data is displayed.
	DATA MONITOR	Displays BCM input/output data in real time.
	ACTIVE TEST	Operation of electrical loads can be checked by sending drive signal to them.
	SELF-DIAG RESULTS	Displays BCM self-diagnosis results.
	CAN DIAG SUPPORT MNTR	The result of transmit/receive diagnosis of CAN communication can be read.
	ECU PART NUMBER	BCM part number can be read.
	CONFIGURATION	Performs BCM configuration read/write functions.

## CONSULT-II OPERATION

### CAUTION:

If CONSULT-II is used with no connection of CONSULT-II CONVERTER, malfunctions might be detected in self-diagnosis depending on control unit which carries out CAN communication.

1. With the ignition switch OFF, connect CONSULT-II and CONSULT-II CONVERTER to the data link connector, then turn ignition switch ON.

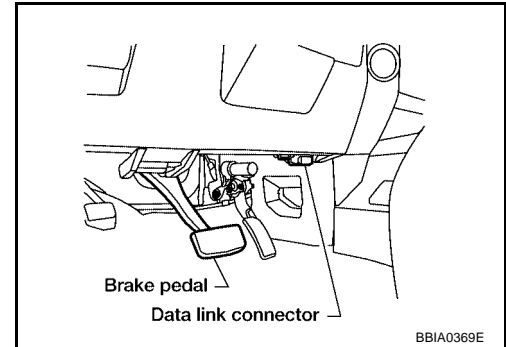

2. Touch "START (NISSAN BASED VHCL)".

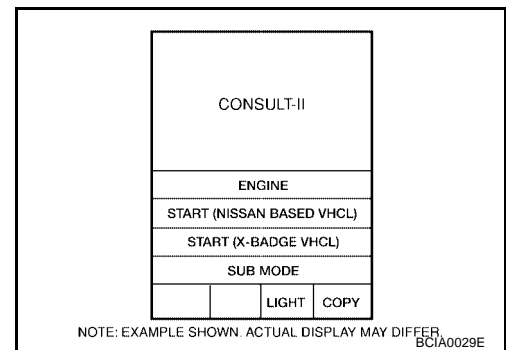

3. Touch "BCM" on "SELECT SYSTEM" screen. If "BCM" is not indicated, go to [GI-38, "CONSULT-II Data Link Connector \(DLC\) Circuit"](#).

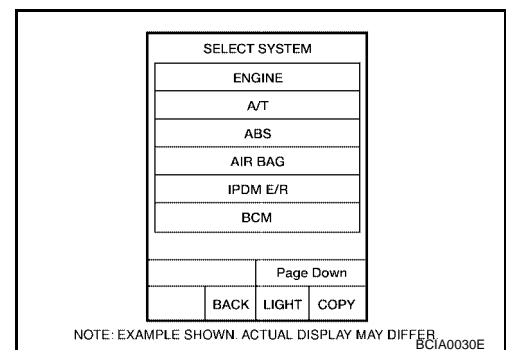

# TURN SIGNAL AND HAZARD WARNING LAMPS

4. Touch "FLASHER" on "SELECT TEST ITEM" screen.

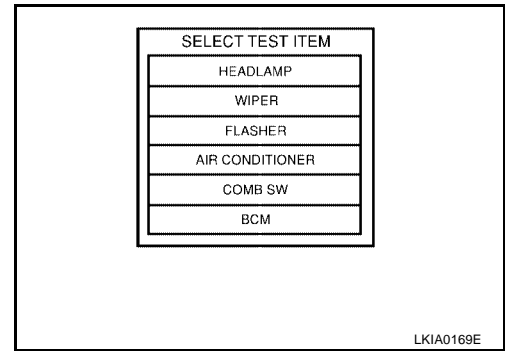

## DATA MONITOR

### Operation Procedure

1. Touch "FLASHER" on "SELECT TEST ITEM" screen.
2. Touch "DATA MONITOR" on "SELECT DIAG MODE" screen.
3. Touch either "ALL SIGNALS" or "SELECTION FROM MENU" on the "SELECT MONITOR ITEM" screen.

All signals	Monitors all the signals.
Selection from menu	Selects and monitors the individual signal.

4. Touch "START".
5. When "SELECTION FROM MENU" is selected, touch items to be monitored. When "ALL SIGNALS" is selected, all the items will be monitored.
6. Touch "RECORD" while monitoring, then the status of the monitored item can be recorded. To stop recording, touch "STOP".

### Display Item List

Monitor item	Contents
IGN ON SW "ON/OFF"	Displays "IGN position (ON)/OFF, ACC position (OFF)" judged from the ignition switch signal.
HAZARD SW "ON/OFF"	Displays "Hazard ON (ON)/Hazard OFF (OFF)" status, determined from hazard switch signal.
TURN SIGNAL R "ON/OFF"	Displays "Turn right (ON)/Other (OFF)" status, determined from lighting switch signal.
TURN SIGNAL L "ON/OFF"	Displays "Turn left (ON)/Other (OFF)" status, determined from lighting switch signal.
BRAKE SW "ON/OFF"	Displays status of stop lamp switch.

## ACTIVE TEST

### Operation Procedure

1. Touch "FLASHER" on "SELECT TEST ITEM" screen.
2. Touch "ACTIVE TEST" on "SELECT DIAG MODE" screen.
3. Touch item to be tested and check operation of the selected item.
4. During the operation check, touching "BACK" or "OFF" deactivates the operation.

### Display Item List

Test item	Description
FLASHER (RH)	Turn signal lamp (right) can be operated by any ON-OFF operations.
FLASHER (LH)	Turn signal lamp (left) can be operated by any ON-OFF operations.



# TURN SIGNAL AND HAZARD WARNING LAMPS

## 4. CHECK GROUND

1. Check continuity between front combination lamp LH harness connector E11 terminal 4 (B) and ground.

**4 (B) - Ground : Continuity should exist.**

2. Check continuity between front combination lamp RH harness connector E107 terminal 4 (B) and ground.

**4 (B) - Ground : Continuity should exist.**

OK or NG

- OK >> GO TO 5.  
NG >> Repair harness or connector.

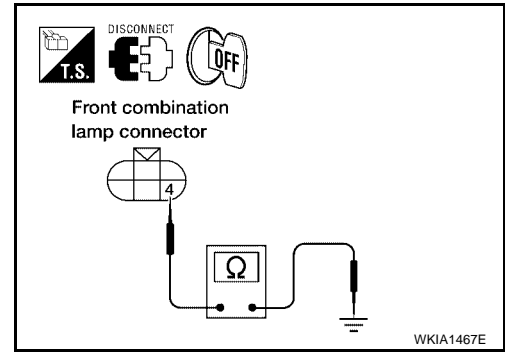

## 5. CHECK BULB

Check bulb standard of each turn signal lamp is correct. Refer to [LT-167, "Exterior Lamp"](#) .

OK or NG

- OK >> Replace BCM if turn signal lamps do not work after setting the connector again. Refer to [BCS-19, "Removal and Installation of BCM"](#) .  
NG >> Replace turn signal lamp bulb. Refer to [LT-30, "FRONT TURN SIGNAL/PARKING LAMP"](#) .

## Rear Turn Signal Lamp Does Not Operate

EKS00AAX

### 1. CHECK TAIL LAMPS AND STOP LAMPS

Check bulb standard of each turn signal lamp is correct. Refer to [LT-167, "Exterior Lamp"](#) .

OK or NG

- OK >> GO TO 2.  
NG >> Replace turn signal lamp bulb. Refer to [LT-118, "Bulb Replacement"](#) .

### 2. CHECK TURN SIGNAL LAMPS CIRCUIT

1. Disconnect BCM connector and rear combination lamp connector.

2. Check continuity between BCM harness connector M20 terminal 61 (G/Y) and rear combination lamp RH harness connector C14 terminal 8 (G/Y).

**61 (G/Y) - 8 (G/Y) : Continuity should exist.**

3. Check continuity between BCM harness connector M20 terminal 60 (G/B) and rear combination lamp LH harness connector C13 terminal 8 (G/B).

**60 (G/B) - 8 (G/B) : Continuity should exist.**

OK or NG

- OK >> GO TO 3.  
NG >> Repair harness or connector.

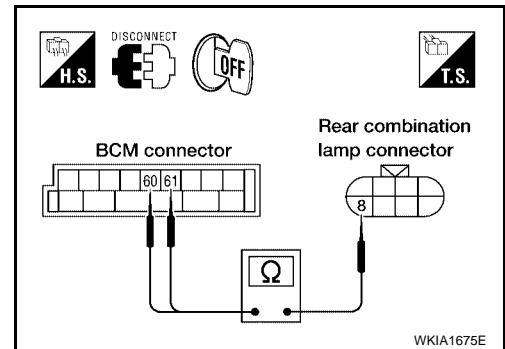

# TURN SIGNAL AND HAZARD WARNING LAMPS

## 3. CHECK GROUND CIRCUIT

Check continuity between rear combination lamp harness connector C13 LH and C14 RH terminal 1 (B) and ground.

**1 (B) - Ground : Continuity should exist.**

OK or NG

- OK >> Check rear combination lamp connector for proper connection. Repair as necessary.
- NG >> Repair harness or connector.

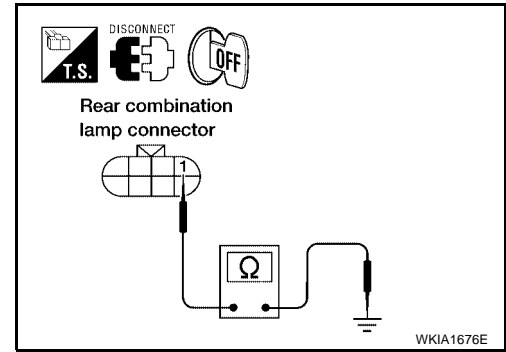

## Hazard Warning Lamp Does Not Operate But Turn Signal Lamps Operate

EKS00AAY

### 1. CHECK BULB

Make sure bulb standard of each turn signal lamp is correct. Refer to [LT-167, "Exterior Lamp"](#).

OK or NG

- OK >> GO TO 2.
- NG >> Replace turn signal lamp bulb. Refer to [LT-30, "FRONT TURN SIGNAL/PARKING LAMP"](#) for front turn signal bulb. Refer to [LT-118, "Bulb Replacement"](#) for rear turn signal bulb.

### 2. CHECK HAZARD SWITCH INPUT SIGNAL

Ⓜ With CONSULT-II

Select "BCM" on CONSULT-II. With "FLASHER" data monitor, make sure "HAZARD SW" turns ON-OFF linked with operation of hazard switch.

**When hazard switch is in ON position : HAZARD SW ON**

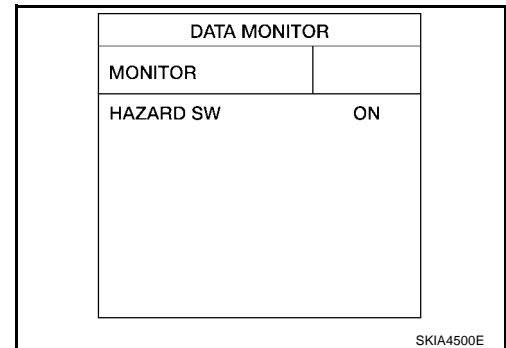

ⓧ Without CONSULT-II

Check voltage between BCM harness connector M18 terminal 29 (W/B) and ground.

Terminals		(-)	Condition	Voltage (Approx.)
(+)	Terminal (Wire color)			
Connector	Terminal (Wire color)			
M18	29 (W/B)	Ground	Hazard switch is ON	0V
			Hazard switch is OFF	5V

OK or NG

- OK >> Replace BCM. Refer to [BCS-19, "Removal and Installation of BCM"](#).
- NG >> GO TO 3.

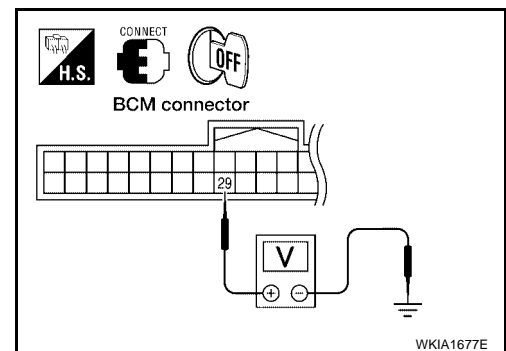

# TURN SIGNAL AND HAZARD WARNING LAMPS

## 3. CHECK HAZARD SWITCH CIRCUIT

1. Turn ignition switch OFF.
2. Disconnect BCM connector and hazard switch connector.
3. Check continuity between BCM harness connector M18 terminal 29 (W/B) and hazard switch harness connector M55 terminal 4 (W/B).

**29 (W/B) - 4 (W/B) : Continuity should exist.**

OK or NG

- OK >> GO TO 4.  
 NG >> Repair harness or connector.

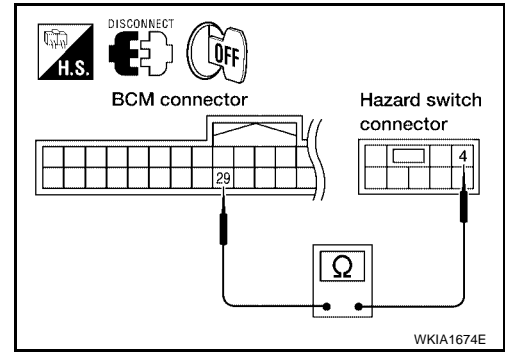

## 4. CHECK GROUND

Check continuity between hazard switch harness connector M55 terminal 6 (B) and ground.

**6 (B) - Ground : Continuity should exist.**

OK or NG

- OK >> GO TO 5.  
 NG >> Repair harness or connector.

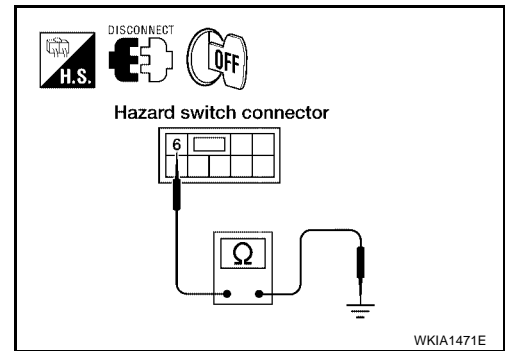

## 5. CHECK HAZARD SWITCH

1. Disconnect hazard switch connector.
2. Check continuity of hazard switch.

Terminal		Condition	Continuity
Hazard switch			
4	6	Hazard switch is ON	Yes
		Hazard switch is OFF	No

OK or NG

- OK >> Replace BCM if turn signal lamps does not work after setting the connector again. Refer to [BCS-19, "Removal and Installation of BCM"](#) .  
 NG >> Replace hazard switch. Refer to [LT-91, "Removal and Installation"](#) .

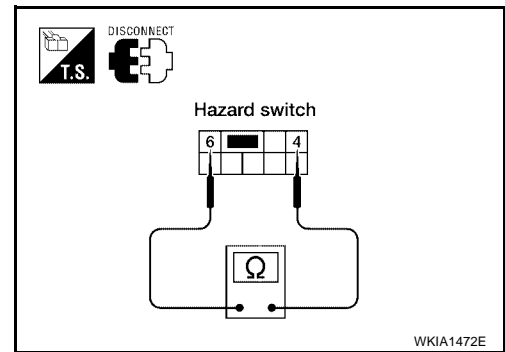

## Turn Signal Indicator Lamp Does Not Operate

EKS00AAZ

### 1. CHECK CAN COMMUNICATION SYSTEM

Check CAN communication. Refer to [LAN-7, "CAN COMMUNICATION"](#) .

OK or NG

- OK >> Replace combination meter. Refer to [IP-13, "COMBINATION METER"](#) .  
 NG >> Repair as necessary.



# TURN SIGNAL AND HAZARD WARNING LAMPS

---

## Bulb Replacement (Front Turn Signal Lamp)

EKS00AB0

Refer to [LT-30, "FRONT TURN SIGNAL/PARKING LAMP"](#) .

A

## Bulb Replacement (Rear Turn Signal Lamp)

EKS00AB1

Refer to [LT-118, "Bulb Replacement"](#) in REAR COMBINATION LAMP.

B

## Removal and Installation of Front Turn Signal Lamp

EKS00AB2

Refer to [LT-31, "Removal and Installation"](#) .

C

## Removal and Installation of Rear Turn Signal Lamp

EKS00AB3

Refer to [LT-118, "Removal and Installation"](#) in REAR COMBINATION LAMP.

D

E

F

G

H

I

J

**LT**

L

M

# LIGHTING AND TURN SIGNAL SWITCH

## LIGHTING AND TURN SIGNAL SWITCH

PF2:25540

### Removal and Installation

EKS00AB4

#### REMOVAL

1. Remove steering column cover.
2. While pressing tabs, pull lighting and turn signal switch toward driver door and disconnect from the base.

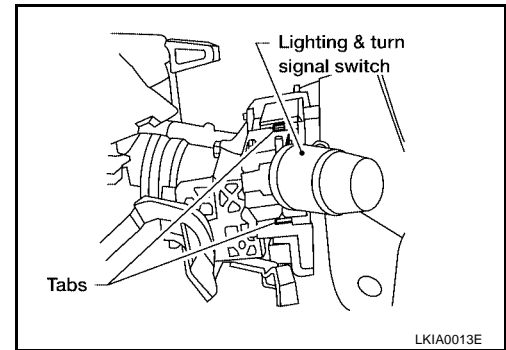

#### INSTALLATION

Installation is in the reverse order of removal.

# HAZARD SWITCH

## HAZARD SWITCH

PF2P:25290

### Removal and Installation

EKS00AB5

#### REMOVAL

1. Remove cluster lid C. Refer to [IP-12, "CLUSTER LID C"](#).
2. While pressing the tab, push out the hazard switch.

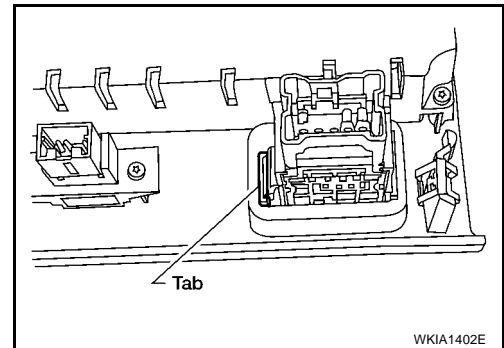

#### INSTALLATION

Installation is in the reverse order of removal.

A  
B  
C  
D  
E  
F  
G  
H  
I  
J  
LT  
L  
M

# COMBINATION SWITCH

PPF:25567

EKS00AB6

## COMBINATION SWITCH

### Wiring Diagram — COMBSW —

## LT-COMBSW-01

— : DATA LINE

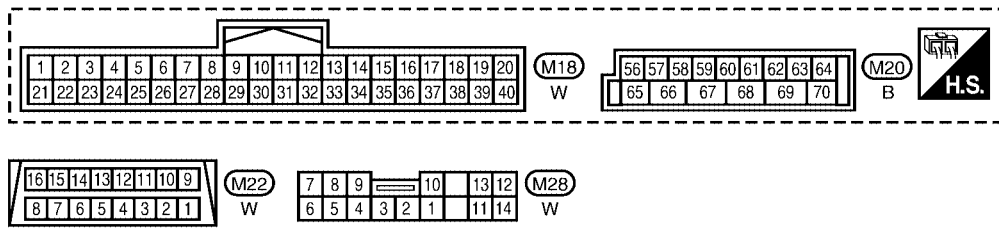
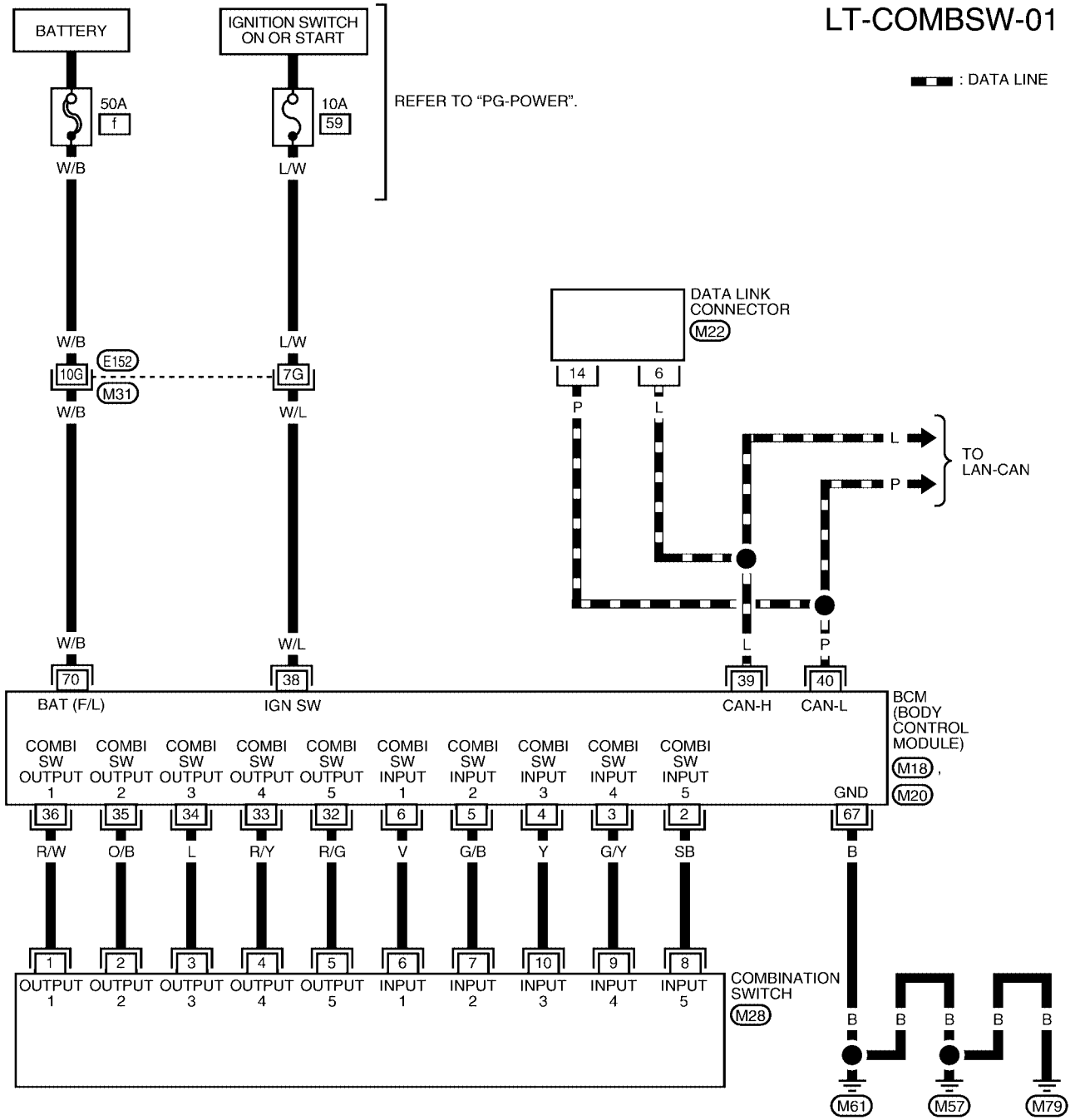

REFER TO THE FOLLOWING.  
 (M31) - SUPER MULTIPLE JUNCTION (SMJ)

WKWA2410E

# COMBINATION SWITCH

## Combination Switch Reading Function

EKS00AB7

For details, refer to [BCS-3, "COMBINATION SWITCH READING FUNCTION"](#).

## CONSULT-II Function (BCM)

EKS00AB8

CONSULT-II can display each diagnostic item using the diagnostic test modes shown following.

BCM diagnostic test item	Diagnostic mode	Description
Inspection by part	WORK SUPPORT	Supports inspections and adjustments. Commands are transmitted to the BCM for setting the status suitable for required operation, input/output signals are received from the BCM and received data is displayed.
	DATA MONITOR	Displays BCM input/output data in real time.
	ACTIVE TEST	Operation of electrical loads can be checked by sending drive signal to them.
	SELF-DIAG RESULTS	Displays BCM self-diagnosis results.
	CAN DIAG SUPPORT MNTR	The result of transmit/receive diagnosis of CAN communication can be read.
	ECU PART NUMBER	BCM part number can be read.
	CONFIGURATION	Performs BCM configuration read/write functions.

## CONSULT-II OPERATION

### CAUTION:

If CONSULT-II is used with no connection of CONSULT-II CONVERTER, malfunctions might be detected in self-diagnosis depending on control unit which carries out CAN communication.

1. With the ignition switch OFF, connect CONSULT-II and CONSULT-II CONVERTER to the data link connector, then turn ignition switch ON.

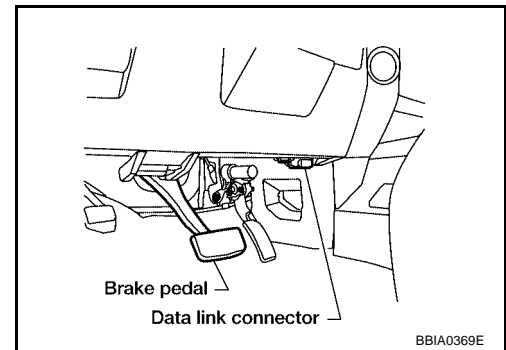

2. Touch "START (NISSAN BASED VHCL)".

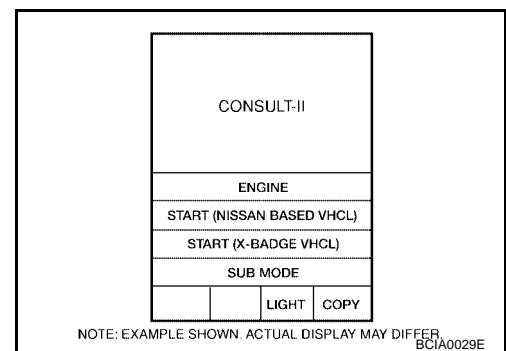

3. Touch "BCM" on "SELECT SYSTEM" screen. If "BCM" is not indicated, go to [GI-38, "CONSULT-II Data Link Connector \(DLC\) Circuit"](#).

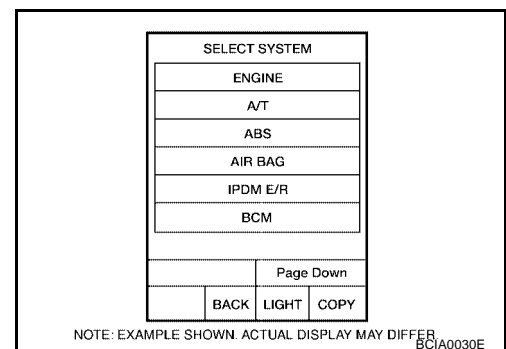

# COMBINATION SWITCH

4. Touch "COMB SW".

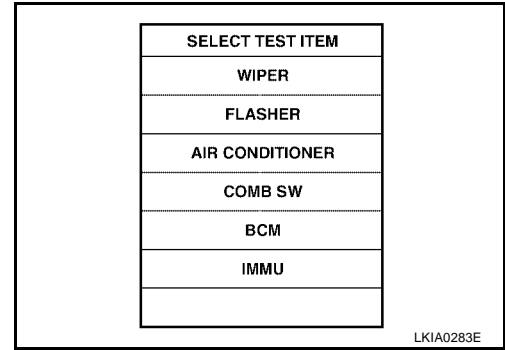

## DATA MONITOR

### Operation Procedure

1. Touch "COMB SW" on "SELECT TEST ITEM" screen.
2. Touch "DATA MONITOR" on "SELECT DIAG MODE" screen.
3. Touch either "ALL SIGNALS" or "SELECTION FROM MENU" on "SELECT MONITOR ITEM" screen.

ALL SIGNALS	Monitors all the signals.
SELECTION FROM MENU	Selects and monitors individual signal.

4. Touch "START".
5. When "SELECTION FROM MENU" is selected, touch items to be monitored. When "ALL SIGNALS" is selected, all the signals will be monitored.
6. Touch "RECORD" while monitoring, then the status of the monitored item can be recorded. To stop recording, touch "STOP".

### Display Item List

Monitor item name "OPERATION OR UNIT"	Contents
TURN SIGNAL R "ON/OFF"	Displays "Turn Right (ON)/Other (OFF)" status, determined from lighting switch signal.
TURN SIGNAL L "ON/OFF"	Displays "Turn Left (ON)/Other (OFF)" status, determined from lighting switch signal.
HI BEAM SW "ON/OFF"	Displays status (high beam switch: ON/Others: OFF) of high beam switch judged from lighting switch signal.
HEAD LAMP SW 1 "ON/OFF"	Displays "Headlamp switch 1 (ON)/Other (OFF)" status, determined from lighting switch signal.
HEAD LAMP SW 2 "ON/OFF"	Displays status (headlamp switch 2: ON/Others: OFF) of headlamp switch 2 judged from lighting switch signal.
LIGHT SW 1ST "ON/OFF"	Displays status (lighting switch 1st position: ON/Others: OFF) of lighting switch judged from lighting switch signal.
PASSING SW "ON/OFF"	Displays status (flash-to-pass switch: ON/Others: OFF) of flash-to-pass switch judged from lighting switch signal.
AUTO LIGHT SW "ON/OFF"	Displays "Auto light switch (ON)/Other (OFF)" status, determined from lighting switch signal.
FR FOG SW "ON/OFF"	Displays "Front fog lamp switch (ON)/Other (OFF)" status, determined from lighting switch signal.
FR WIPER HI "ON/OFF"	Displays "Front Wiper HI (ON)/Other (OFF)" status, determined from wiper switch signal.
FR WIPER LOW "ON/OFF"	Displays "Front Wiper LOW (ON)/Other (OFF)" status, determined from wiper switch signal.
FR WIPER INT "ON/OFF"	Displays "Front Wiper INT (ON)/Other (OFF)" status, determined from wiper switch signal.
FR WASHER SW "ON/OFF"	Displays "Front Washer Switch (ON)/Other (OFF)" status, determined from wiper switch signal.
INT VOLUME [1 - 7]	Displays intermittent operation knob setting (1 - 7), determined from wiper switch signal.

# COMBINATION SWITCH

EKS00AB9

## Combination Switch Inspection

### 1. SYSTEM CHECK

Referring to table below, check to which system the malfunctioning switch belongs.

System 1	System 2	System 3	System 4	System 5
—	FR WASHER	FR WIPER LO	TURN LH	TURN RH
FR WIPER HI	—	FR WIPER INT	PASSING	HEAD LAMP1
INT VOLUME 1	—	—	HEAD LAMP2	HI BEAM
—	INT VOLUME 3	AUTO LIGHT	—	TAIL LAMP
INT VOLUME 2	—	—	FR FOG	—

>> GO TO 2.

### 2. SYSTEM CHECK

 With CONSULT-II

#### CAUTION:

If CONSULT-II is used with no connection of CONSULT-II CONVERTER, malfunctions might be detected in self-diagnosis depending on control unit which carries out CAN communication.

1. Connect CONSULT-II, and select "COMB SW" on "SELECT TEST ITEM" screen.
2. Select "DATA MONITOR".
3. Select "START", and confirm that other switches in malfunctioning system operate normally.

Example: When auto light switch is malfunctioning, confirm that "FRONT WIPER LOW" and "FRONT WIPER INT" in System 3, to which the auto light switch belongs, turn ON-OFF normally.

DATA MONITOR	
MONITOR	
TURN SIGNAL R	OFF
TURN SIGNAL L	OFF
HIBEAM SW	OFF
HEAD LAMP SW1	OFF
HEAD LAMP SW2	OFF
LIGHT SW 1ST	OFF
PASSING SW	OFF
AUTO LIGHT SW	OFF
FR FOG SW	OFF
Page Down	
RECORD	
MODE	BACK
LIGHT	COPY

SKIA7075E

 Without CONSULT-II

Operate combination switch, and confirm that other switches in malfunctioning system operate normally.

Example: When auto light switch is malfunctioning, confirm that "FRONT WIPER LOW" and "FRONT WIPER INT" in System 3, to which the auto light switch belongs, operate normally.

#### Check results

Other switches in malfunctioning system operate normally.>>Replace lighting switch or wiper switch.

Other switches in malfunctioning system do not operate normally.>>GO TO 3.

# COMBINATION SWITCH

## 3. HARNESS INSPECTION

1. Disconnect BCM and combination switch connectors.
2. Check for continuity between BCM harness connector of the suspect system and the corresponding combination switch connector terminals.

Suspect system	Terminals				Continuity	
	BCM		Combination switch			
	Connector	Terminal (Wire color)	Connector	Terminal (Wire color)		
1	M18	Input 1	6 (V)	M28	6 (V)	Yes
		Output 1	36 (R/W)		1 (R/W)	
2		Input 2	5 (G/B)		7 (G/B)	
		Output 2	35 (O/B)		2 (O/B)	
3		Input 3	4 (Y)		10 (Y)	
		Output 3	34 (L)		3 (L)	
4		Input 4	3 (G/Y)		9 (G/Y)	
		Output 4	33 (R/Y)		4 (R/Y)	
5		Input 5	2 (SB)		8 (SB)	
		Output 5	32 (R/G)		5 (R/G)	

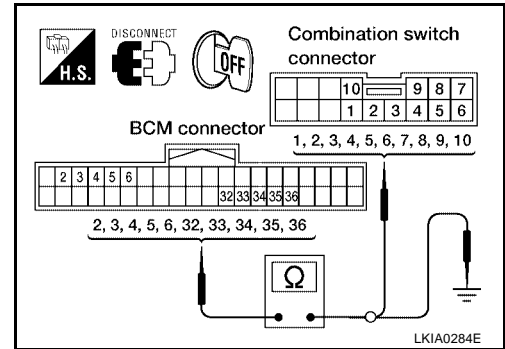

3. Check for continuity between each terminal of BCM harness connector in suspect malfunctioning system and ground.

Suspect system	Terminals				Continuity
	BCM				
	Connector	Terminal (Wire color)			
1	M18	Input 1	6 (V)	Ground	No
		Output 1	36 (R/W)		
2		Input 2	5 (G/B)		
		Output 2	35 (O/B)		
3		Input 3	4 (Y)		
		Output 3	34 (L)		
4		Input 4	3 (G/Y)		
		Output 4	33 (R/Y)		
5		Input 5	2 (SB)		
		Output 5	32 (R/G)		

**OK or NG**

OK >> GO TO 4.

NG >> Check harness between BCM and combination switch for open or short circuit.



# COMBINATION SWITCH

## 4. BCM OUTPUT TERMINAL INSPECTION

1. Turn lighting switch and wiper switch to OFF.
2. Set wiper dial to position 4.
3. Connect BCM and combination switch connectors, and check BCM output terminal voltage waveform of suspect malfunctioning system.

Suspect system	Terminals	
	Combination switch (+)	
	Connector	Terminal (Wire color)
1	M28	Output 1 1 (R/W)
2		Output 2 2 (O/B)
3		Output 3 3 (L)
4		Output 4 4 (R/Y)
5		Output 5 5 (R/G)

### OK or NG

- OK >> Open circuit in combination switch, GO TO 5.  
 NG >> Replace BCM. Refer to [BCS-19, "Removal and Installation of BCM"](#).

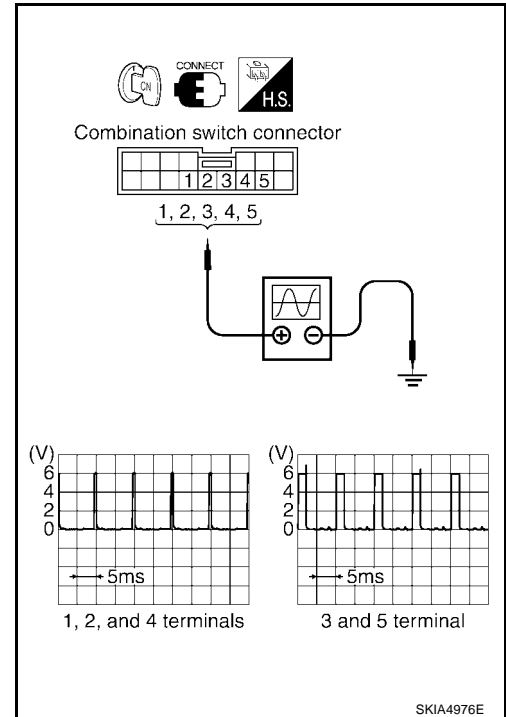

## 5. COMBINATION SWITCH INSPECTION

Referring to table below, perform combination switch inspection.

Procedure									
1	2		3	4		5	6		7
Replace lighting switch.	Confirm check results.	OK	INSPECTION END	Confirm check results.	OK	INSPECTION END	Confirm check results.	OK	INSPECTION END
		NG	Replace wiper switch.		NG	Replace switch base.		NG	Confirm symptom again.

>> Inspection End.

### Removal and Installation

For details, refer to [LT-90, "Removal and Installation"](#).

### Switch Circuit Inspection

For details, refer to [LT-95, "Combination Switch Inspection"](#).

# STOP LAMP

---

## STOP LAMP

PF2:26550

### System Description

EKS00ABC

Power is supplied at all times

- through 10A fuse [No. 20, located in fuse block (J/B)]
- to stop lamp switch terminal 1 and
- to stop lamp relay terminal 1 (with VDC).

When the brake pedal is pressed, the stop lamp switch is closed and power is supplied

- through stop lamp switch terminal 2
- to stop lamp relay terminal 3 (with VDC)
- through stop lamp relay terminal 4 (with VDC)
- to rear combination lamp LH and RH terminal 7, and
- to high-mounted stop lamp terminal 1.

Ground is supplied

- to rear combination lamp LH and RH terminal 5
- through grounds E9, E15 and E24, and
- to high-mounted stop lamp terminal 2
- through grounds B117 and B132.

With power and ground supplied, the stop lamps illuminate.

# STOP LAMP

## Wiring Diagram — STOP/L —

EKS00ABD

### LT-STOP/L-01

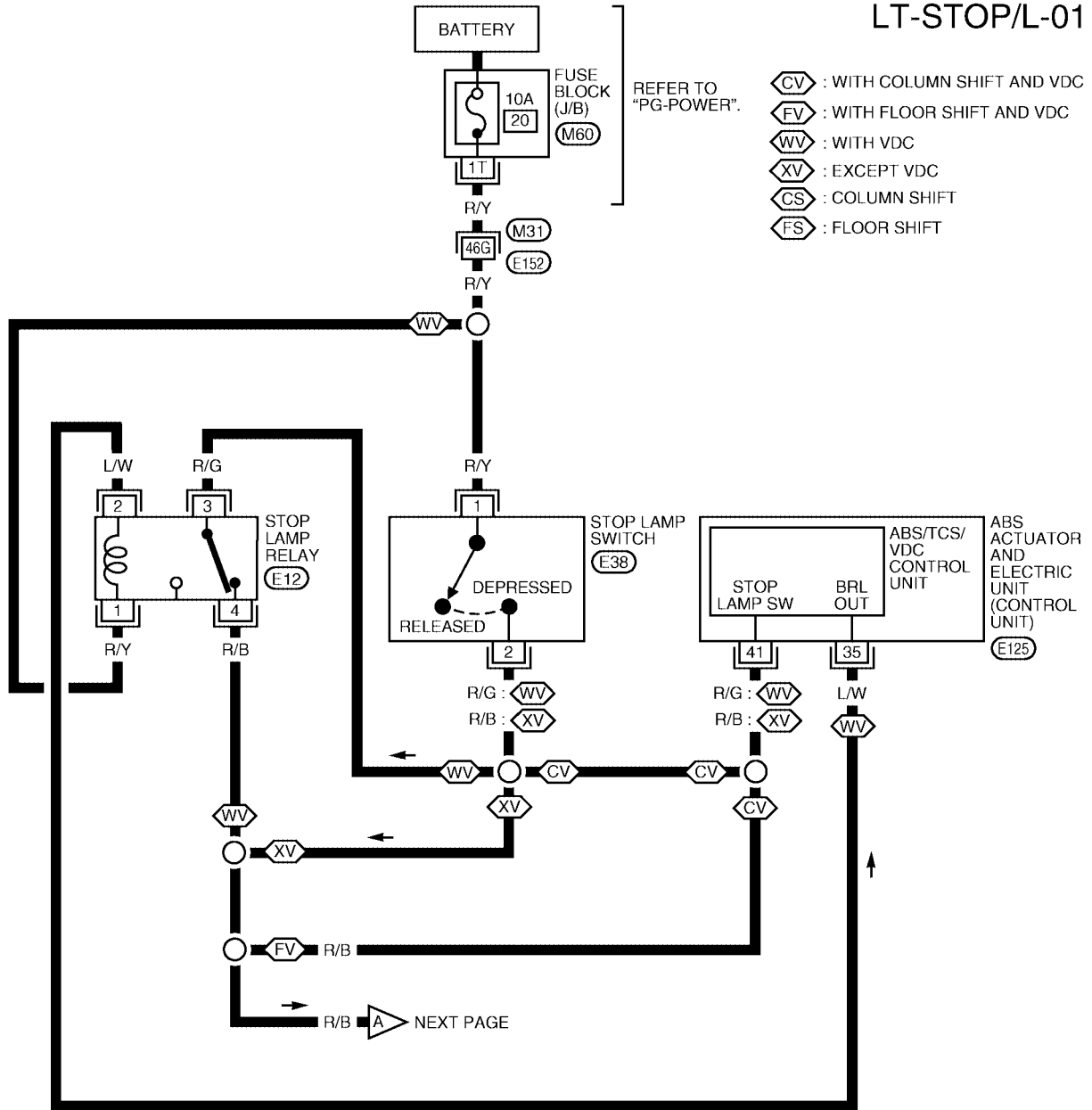

A  
B  
C  
D  
E  
F  
G  
H  
I  
J  
K  
L  
M

LT

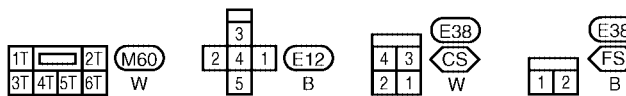

REFER TO THE FOLLOWING.

- (M31) - SUPER MULTIPLE JUNCTION (SMJ)
- (E125) - ELECTRICAL UNITS

WKWA1534E

# STOP LAMP

LT-STOP/L-02

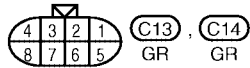
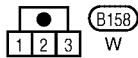
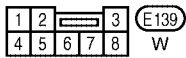
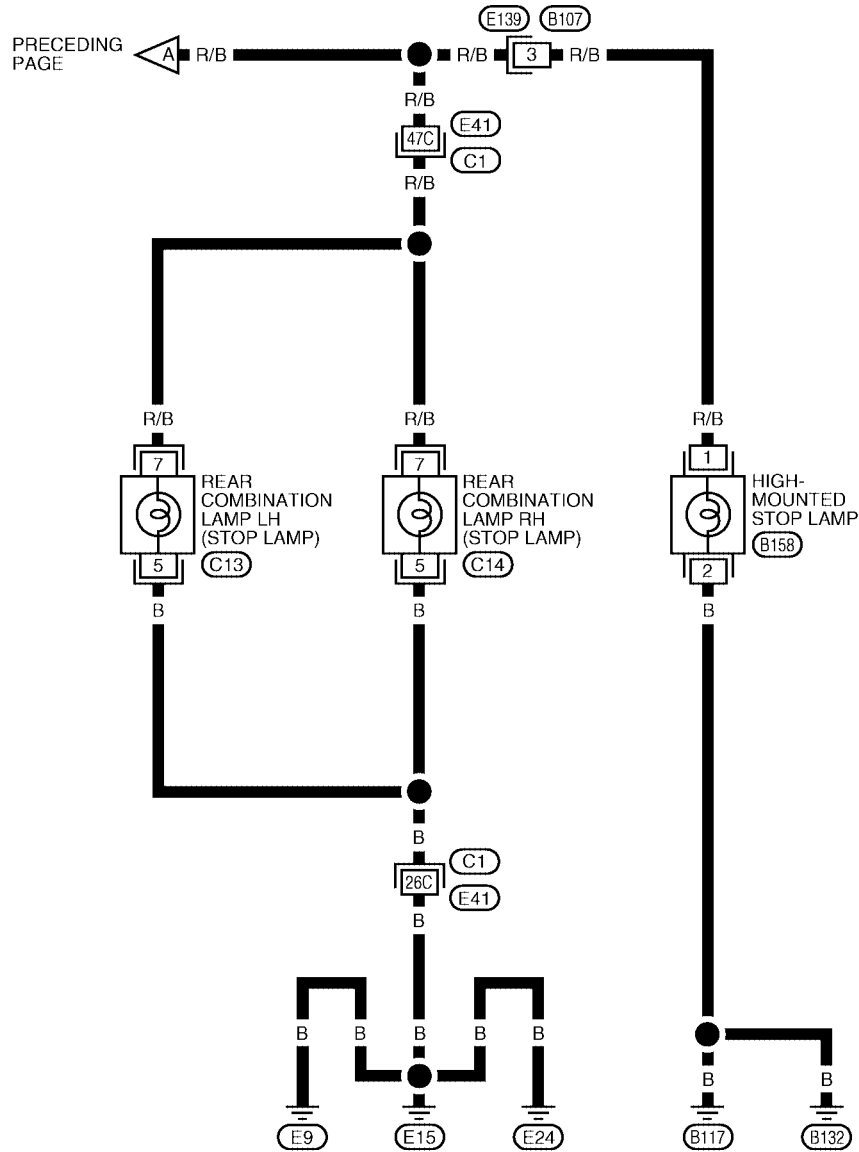

REFER TO THE FOLLOWING.  
**(C1)** - SUPER MULTIPLE JUNCTION (SMJ)

WKWA1510E

# STOP LAMP

## High-Mounted Stop Lamp BULB REPLACEMENT

EKS00ABE

1. Remove the high-mounted stop lamp. Refer to [LT-101, "REMOVAL AND INSTALLATION"](#) .
2. Turn bulb socket counter clockwise to remove it from lamp housing.
3. Pull bulb from socket.

## REMOVAL AND INSTALLATION

1. Remove access caps.
2. Disconnect the connector.
3. Remove 2 nuts and remove high-mounted stop lamp.

Installation is in the reverse order of removal.

**High-mounted stop lamp nuts: 3.38 N-m (0.34 kg-m, 30 in-lb)**

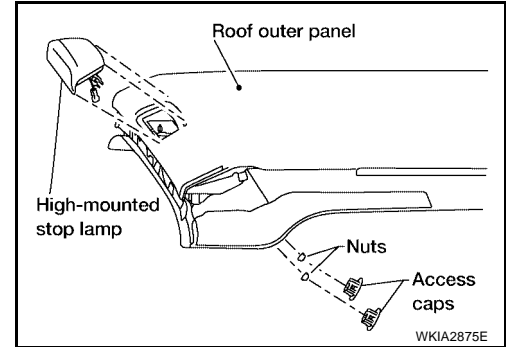

## Stop Lamp BULB REPLACEMENT

EKS00ABF

Refer to [LT-118, "Bulb Replacement"](#) in REAR COMBINATION LAMP.

## REMOVAL AND INSTALLATION

Refer to [LT-118, "Removal and Installation"](#) in REAR COMBINATION LAMP.

A

B

C

D

E

F

G

H

I

J

LT

L

M

# BACK-UP LAMP

PPF:26550

EKS00ABG

## BACK-UP LAMP

### Wiring Diagram — BACK/L —

## LT-BACK/L-01

: WITH NAVI

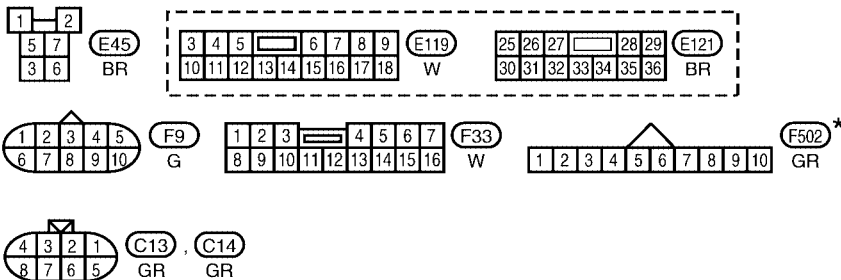
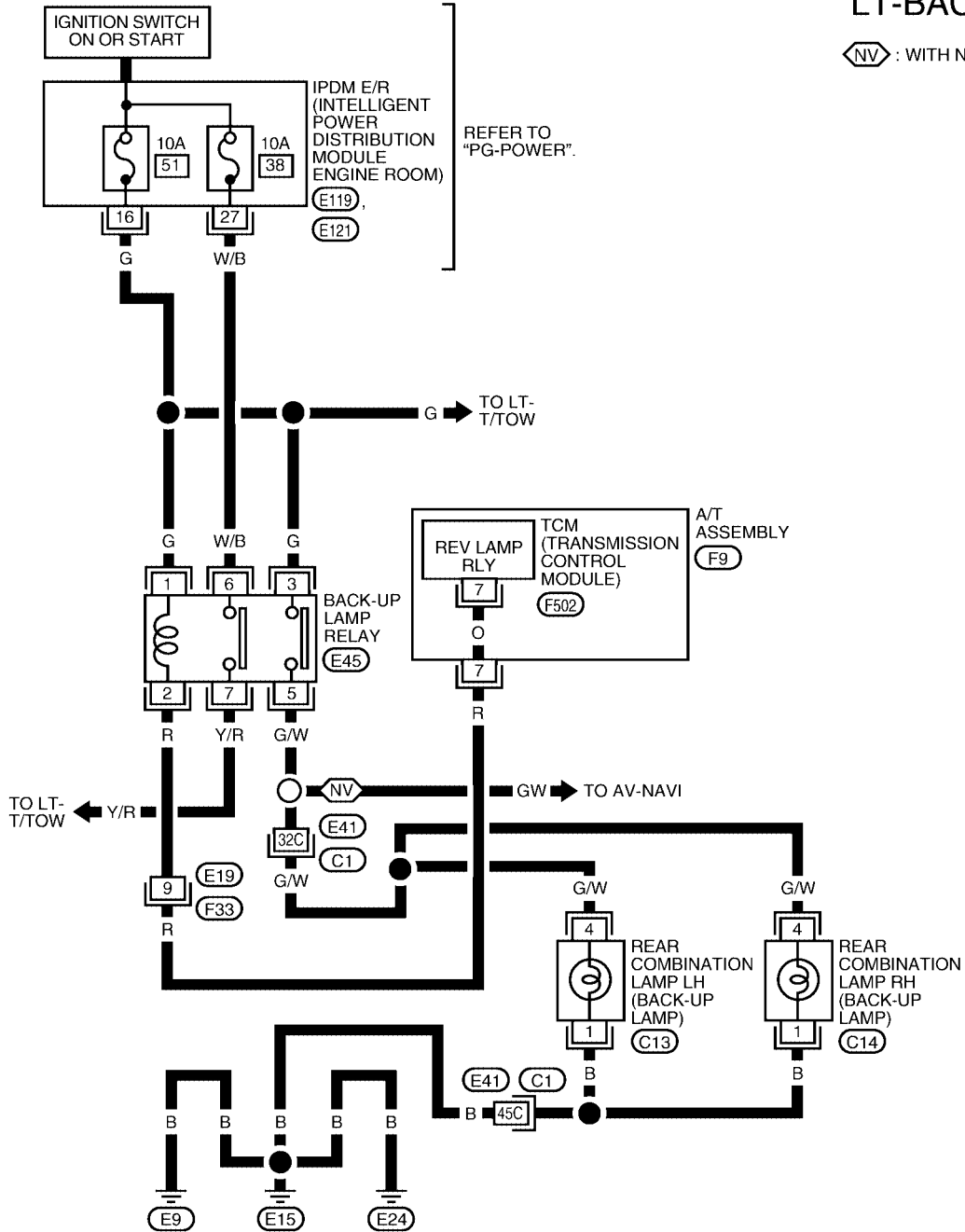

REFER TO THE FOLLOWING.

- SUPER MULTIPLE JUNCTION (SMJ)

\*: THIS CONNECTOR IS NOT SHOWN IN "HARNESS LAYOUT" OF PG SECTION.

WKWA2447E

# BACK-UP LAMP

---

## Bulb Replacement

EKS00ABH

Refer to [LT-118, "Bulb Replacement"](#) in REAR COMBINATION LAMP.

A

## Removal and Installation

EKS00ABI

Refer to [LT-118, "Removal and Installation"](#) in REAR COMBINATION LAMP.

B

C

D

E

F

G

H

I

J

**LT**

L

M

## PARKING, LICENSE PLATE AND TAIL LAMPS

PF2:26550

### Component Parts and Harness Connector Location

EKS00ABJ

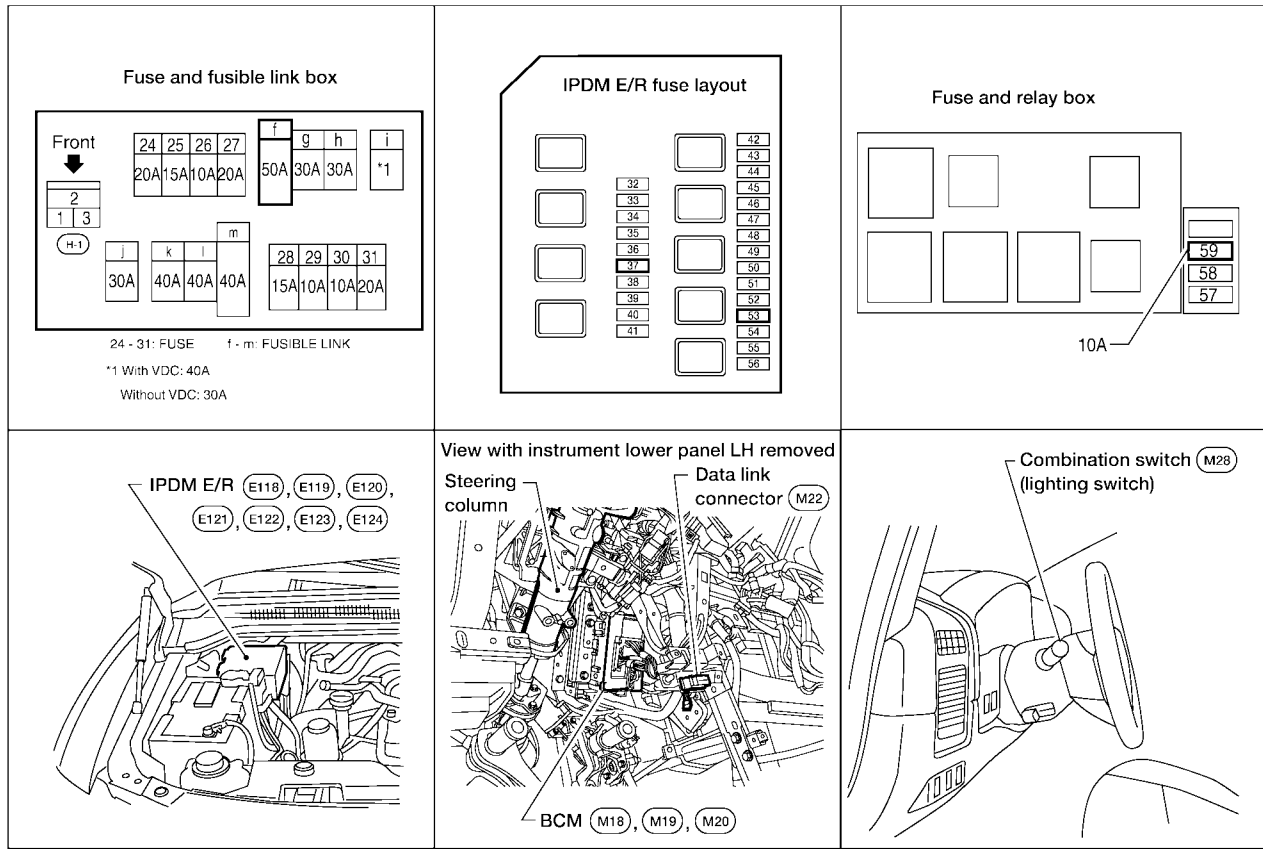

WKIA3584E

### System Description

EKS00ABK

Control of the parking, license plate, and tail lamp operation is dependent upon the position of the lighting switch (combination switch). When the lighting switch is placed in the 1ST position, the BCM (body control module) receives input signal requesting the parking, license plate, side marker and tail lamps to illuminate. This input signal is communicated to the IPDM E/R (intelligent power distribution module engine room) across the CAN communication lines. The CPU (central processing unit) of the IPDM E/R controls the tail lamp relay coil. This relay, when energized, directs power to the parking, license plate and tail lamps, which then illuminate.

Power is supplied at all times

- to tail lamp relay, located in the IPDM E/R, and
- through 20A fuse (No. 53, located in the IPDM E/R)
- to CPU in the IPDM E/R, and
- to ignition relay, located in the IPDM E/R, and
- through 50A fusible link (letter f , located in the fuse and fusible link box)
- to BCM terminal 70.

With the ignition switch in the ON or START position, power is supplied

- through 10A fuse (No. 59, located in the fuse and relay box)
- to BCM terminal 38, and
- to ignition relay, located in the IPDM E/R.

Ground is supplied

- to BCM terminal 67
- through grounds M57, M61 and M79, and
- to IPDM E/R terminals 38 and 59
- through grounds E9, E15 and E24.



# PARKING, LICENSE PLATE AND TAIL LAMPS

## OPERATION BY LIGHTING SWITCH

With the lighting switch in the 1ST or 2ND position (or if the auto light system is activated), the BCM receives input signal requesting the parking, license plate, side marker and tail lamps to illuminate. This input signal is communicated to the IPDM E/R across the CAN communication lines. The CPU in the IPDM E/R controls the tail lamp relay coil, which when energized, directs power

- through 10A fuse (No. 37, located in the IPDM E/R)
- through IPDM E/R terminal 57
- to front combination lamp LH and RH terminal 6
- to license plate lamps terminal + and
- to rear combination lamp LH and RH terminal 6.

Ground is supplied

- to front combination lamp LH and RH terminal 4
- to rear combination lamp LH and RH terminal 1 and
- to license plate lamps terminal –
- through grounds E9, E15 and E24.

With power and ground supplied, the parking, license plate and tail lamps illuminate.

## COMBINATION SWITCH READING FUNCTION

Refer to [BCS-3, "COMBINATION SWITCH READING FUNCTION"](#) .

## EXTERIOR LAMP BATTERY SAVER CONTROL

When the combination switch (lighting switch) is in the 1ST (or 2ND) position, and the ignition switch is turned from ON or ACC to OFF, the battery saver control feature is activated.

Under this condition, the parking, license and tail lamps remain illuminated for 5 minutes, then the parking, license plate and tail lamps are turned off.

Exterior lamp battery saver control mode can be changed by the function setting of CONSULT-II.

## CAN Communication System Description

Refer to [LAN-7, "CAN COMMUNICATION"](#) .

EKS00ABL

A

B

C

D

E

F

G

H

I

J

LT

L

M

# PARKING, LICENSE PLATE AND TAIL LAMPS

## Schematic

EKS00ABM

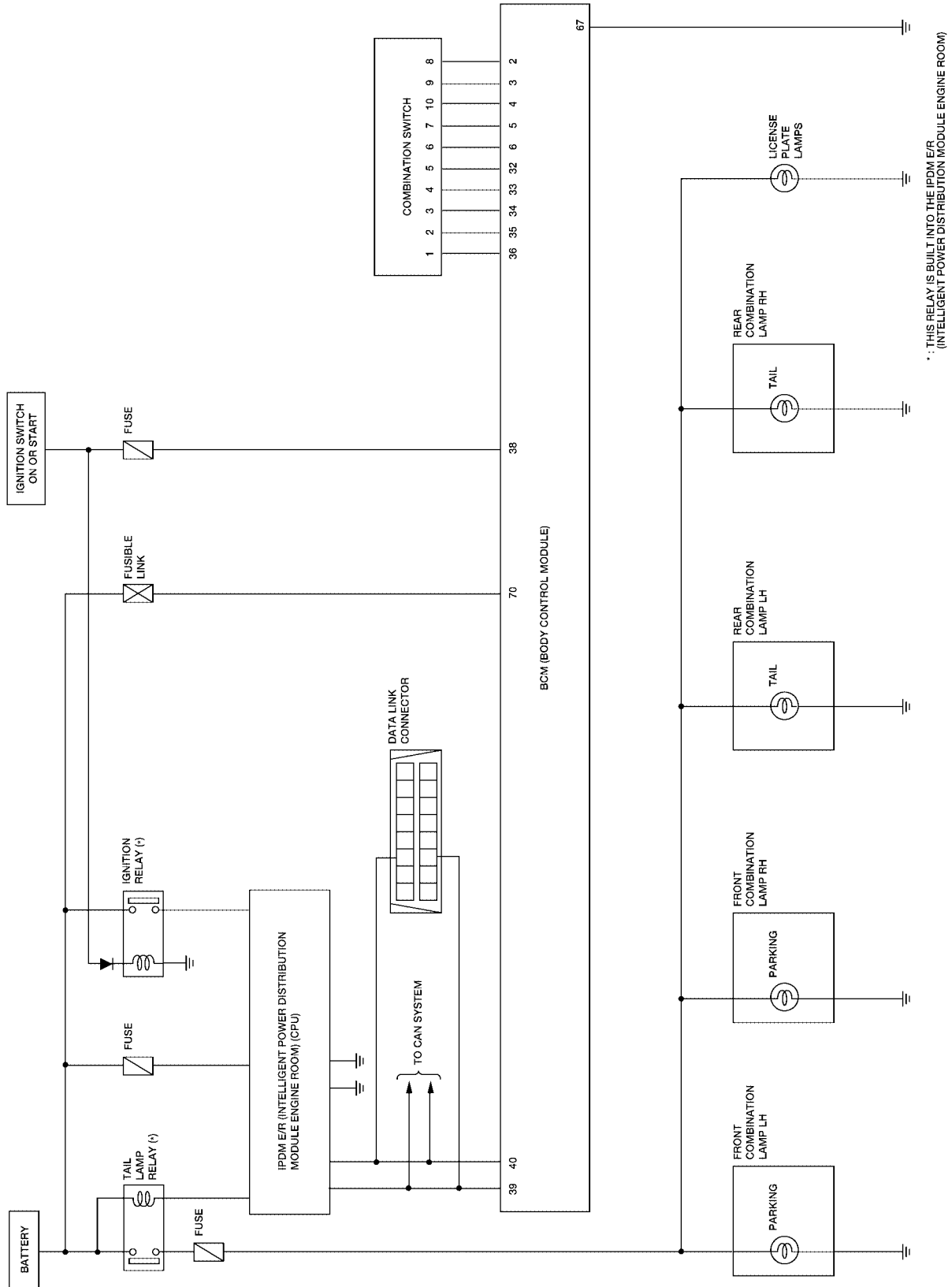

\*: THIS RELAY IS BUILT INTO THE IPDM E/R (INTELLIGENT POWER DISTRIBUTION MODULE ENGINE ROOM)

WKWA2413E

# PARKING, LICENSE PLATE AND TAIL LAMPS

## Wiring Diagram — TAIL/L —

EKS00ABN

### LT-TAIL/L-01

— : DATA LINE

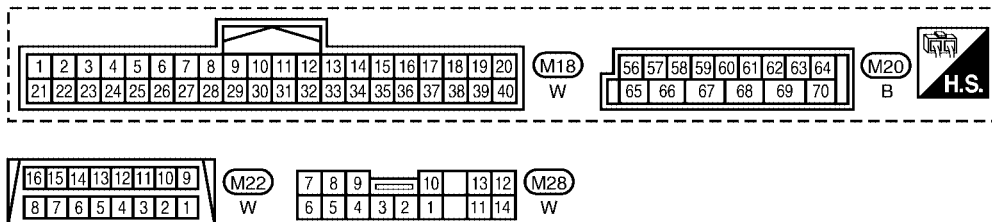
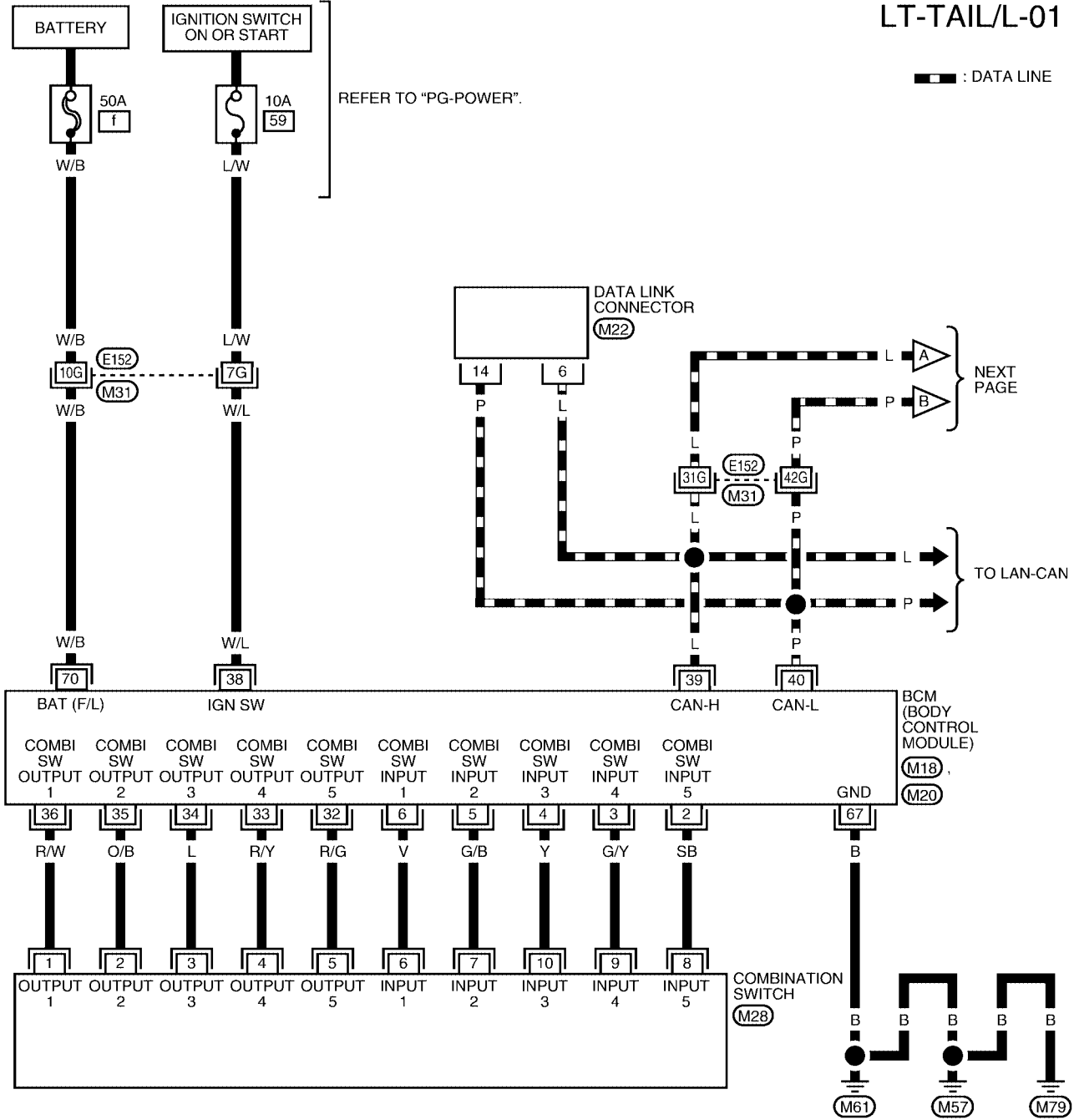

REFER TO THE FOLLOWING.  
 (M31) - SUPER MULTIPLE JUNCTION (SMJ)

WKWA2414E

# PARKING, LICENSE PLATE AND TAIL LAMPS

LT-TAIL/L-02

— : DATA LINE

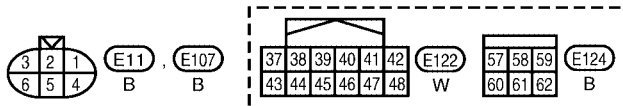
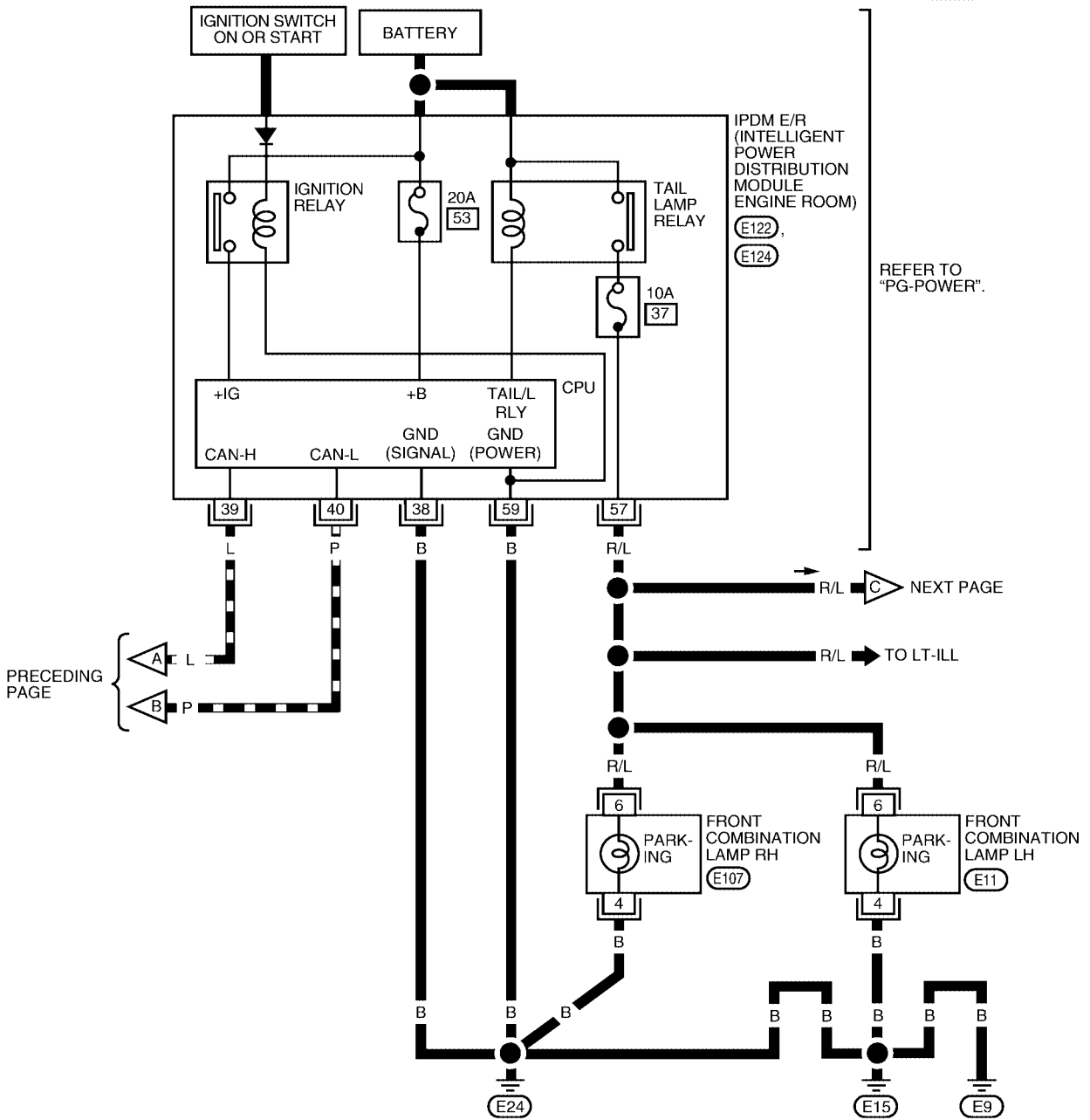

WKWA2415E

# PARKING, LICENSE PLATE AND TAIL LAMPS

LT-TAIL/L-03

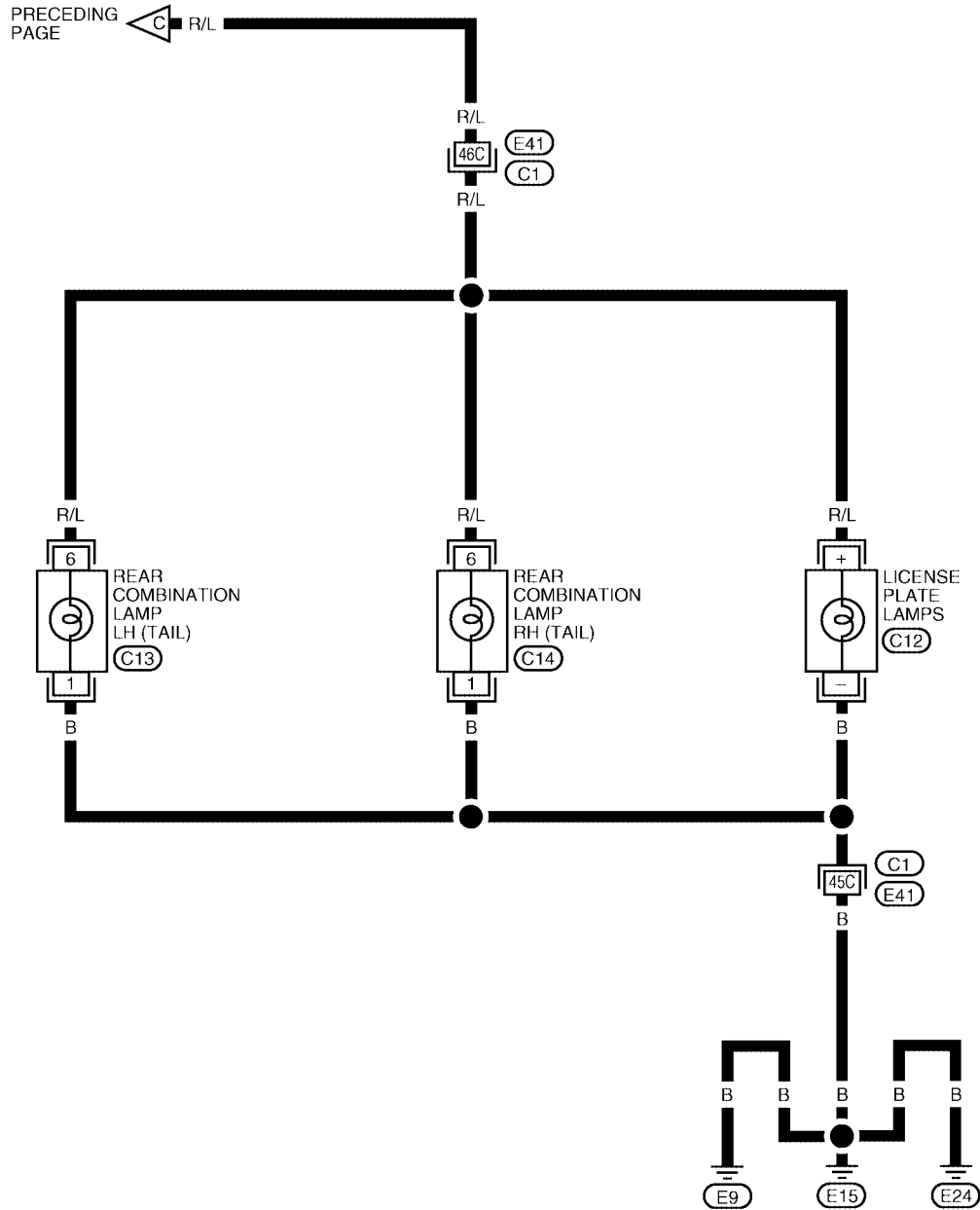

A  
B  
C  
D  
E  
F  
G  
H  
I  
J  
LT  
L  
M

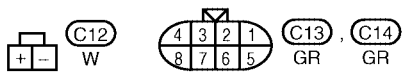





REFER TO THE FOLLOWING.  
 (C1) - SUPER MULTIPLE JUNCTION (SMJ)

WKWA1562E

# PARKING, LICENSE PLATE AND TAIL LAMPS

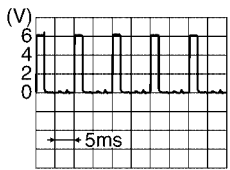
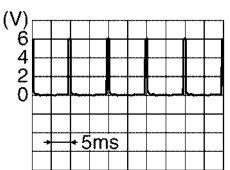
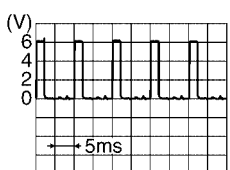
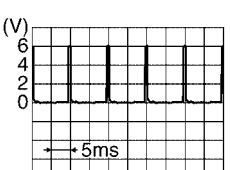
## Terminals and Reference Values for BCM

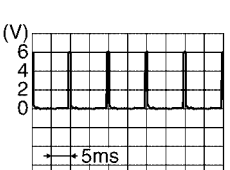
EKS00AB0

Terminal No.	Wire color	Signal name	Measuring condition		Reference value (Approx.)
			Ignition switch	Operation or condition	
2	SB	Combination switch input 5	ON	Lighting, turn, wiper OFF Wiper dial position 4	 <p style="text-align: right;">SKIA5291E</p>
3	G/Y	Combination switch input 4	ON	Lighting, turn, wiper OFF Wiper dial position 4	 <p style="text-align: right;">SKIA5292E</p>
4	Y	Combination switch input 3	ON	Lighting, turn, wiper OFF Wiper dial position 4	 <p style="text-align: right;">SKIA5291E</p>
5	G/B	Combination switch input 2	ON	Lighting, turn, wiper OFF Wiper dial position 4	 <p style="text-align: right;">SKIA5292E</p>
6	V	Combination switch input 1			
32	R/G	Combination switch output 5	ON	Lighting, turn, wiper OFF Wiper dial position 4	 <p style="text-align: right;">SKIA5291E</p>
33	R/Y	Combination switch output 4	ON	Lighting, turn, wiper OFF Wiper dial position 4	 <p style="text-align: right;">SKIA5292E</p>
34	L	Combination switch output 3	ON	Lighting, turn, wiper OFF Wiper dial position 4	 <p style="text-align: right;">SKIA5291E</p>

# PARKING, LICENSE PLATE AND TAIL LAMPS

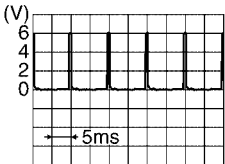
Terminal No.	Wire color	Signal name	Measuring condition		Reference value (Approx.)
			Ignition switch	Operation or condition	
35	O/B	Combination switch output 2	ON	Lighting, turn, wiper OFF Wiper dial position 4	
36	R/W	Combination switch output 1			
38	W/L	Ignition switch (ON)	ON	—	Battery voltage
39	L	CAN-H	—	—	—
40	P	CAN-L	—	—	—
67	B	Ground	ON	—	0V
70	W/B	Battery power supply (fusible link)	OFF	—	Battery voltage

## Terminals and Reference Values for IPDM E/R

EKS00ABP

Terminal No.	Wire color	Signal name	Measuring condition		Reference value (Approx.)	
			Ignition switch	Operation or condition		
38	B	Ground	ON	—	0V	
39	L	CAN-H	—	—	—	
40	P	CAN-L	—	—	—	
57	R/L	Parking, license, and tail lamp	ON	Lighting switch 1ST position	OFF	0V
					ON	Battery voltage
59	B	Ground	ON	—	0V	

## How to Proceed With Trouble Diagnosis

EKS00ABQ

1. Confirm the symptom or customer complaint.
2. Understand operation description and function description. Refer to [LT-104, "System Description"](#) .
3. Carry out the Preliminary Check. Refer to [LT-112, "Preliminary Check"](#) .
4. Check symptom and repair or replace the cause of malfunction.
5. Do the parking, license and tail lamps operate normally? If YES: GO TO 6. If NO: GO TO 4.
6. Inspection End.

# PARKING, LICENSE PLATE AND TAIL LAMPS

EKS00ABR

## Preliminary Check CHECK POWER SUPPLY AND GROUND CIRCUIT

### 1. CHECK FUSES OR FUSIBLE LINK

Check for blown fuses or fusible link.

Unit	Power source	Fuse No.
BCM	Battery	f
	Ignition switch ON or START position	59
IPDM E/R	Battery	53
	Battery (Tail lamps ON)	37

Refer to [LT-107, "Wiring Diagram — TAIL/L —"](#) .

OK or NG

OK >> GO TO 2.

NG >> If fuse is blown, be sure to eliminate cause of malfunction before installing new fuse. Refer to [PG-4, "POWER SUPPLY ROUTING CIRCUIT"](#) .

### 2. CHECK POWER SUPPLY CIRCUIT

1. Disconnect BCM connectors.
2. Check voltage between BCM harness connector and ground.

Terminals		Ignition switch position			
(+)	(-)		OFF	ACC	ON
Connector	Terminal (Wire color)				
M18	38 (W/L)	Ground	0V	0V	Battery voltage
M20	70 (W/B)	Ground	Battery voltage	Battery voltage	Battery voltage

OK or NG

OK >> GO TO 3.

NG >> Check harness for open between BCM and fuse.

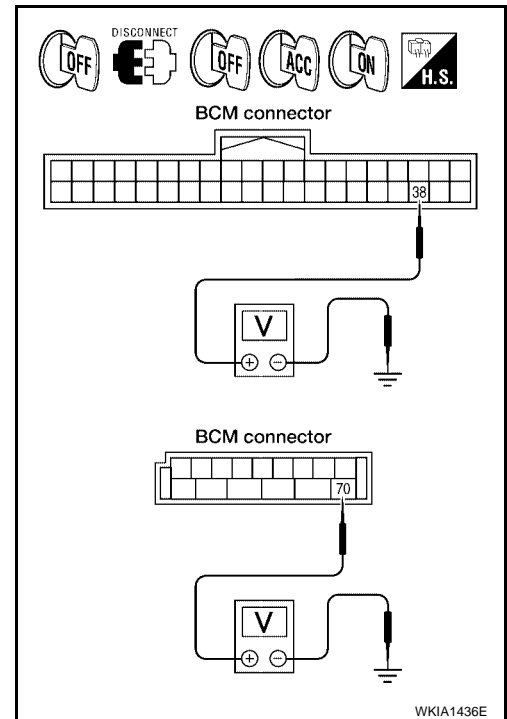

WKIA1436E

### 3. CHECK GROUND CIRCUIT

Check continuity between BCM harness connector and ground.

Terminals		Continuity
Connector	Terminal (Wire color)	
M20	67 (B)	Ground Yes

OK or NG

OK >> Inspection End.

NG >> Check ground circuit harness.

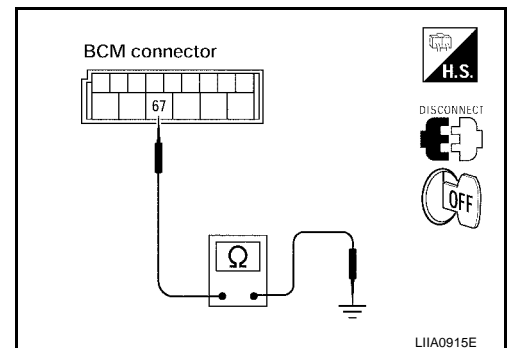

LIA0915E



# PARKING, LICENSE PLATE AND TAIL LAMPS

## CONSULT-II Functions

EKS00ABS

Refer to [LT-17, "CONSULT-II Function \(BCM\)"](#) and [LT-20, "CONSULT-II Function \(IPDM E/R\)"](#) in HEAD-LAMP (FOR USA).

## Parking, License Plate and/or Tail Lamps Do Not Illuminate

EKS00ABT

### 1. CHECK COMBINATION SWITCH INPUT SIGNAL

 With CONSULT-II  
Select "BCM" on CONSULT-II. With "HEAD LAMP" data monitor, make sure "LIGHT SW 1ST" turns ON-OFF linked with operation of lighting switch.

**When lighting switch is in : LIGHT SW 1ST ON  
1ST position**

 Without CONSULT-II  
Refer to [LT-95, "Combination Switch Inspection"](#).

OK or NG

OK >> GO TO 2.

NG >> Check lighting switch. Refer to [LT-95, "Combination Switch Inspection"](#).

DATA MONITOR	
MONITOR	
LIGHT SW 1ST	ON

SKIA5956E

### 2. ACTIVE TEST

-  With CONSULT-II
1. Select "IPDM E/R" on CONSULT-II, and select "ACTIVE TEST" on "SELECT DIAG MODE" screen.
  2. Select "EXTERNAL LAMPS" on "SELECT TEST ITEM" screen.
  3. Touch "TAIL" on "ACTIVE TEST" screen.
  4. Make sure parking, license plate and tail lamps operate.

**Parking, license plate and tail lamps should operate**

 Without CONSULT-II

1. Start auto active test. Refer to [PG-22, "Auto Active Test"](#).
2. Make sure parking, license plate and tail lamps operate.

**Parking, license plate and tail lamps should operate**

OK or NG

OK >> GO TO 3.

NG >> GO TO 4.

ACTIVE TEST			
EXTERNAL LAMPS		OFF	
		TAIL	
LO		HI	
FOG			
MODE	BACK	LIGHT	COPY

WKIA1438E

### 3. CHECK IPDM E/R

1. Select "IPDM E/R" on CONSULT-II, and select "DATA MONITOR" on "SELECT DIAG MODE" screen.
2. Make sure "TAIL & CLR REQ" turns ON when lighting switch is in 1ST position.

**When lighting switch is in : TAIL & CLR REQ ON  
1ST position**

OK or NG

OK >> Replace IPDM E/R. Refer to [PG-28, "Removal and Installation of IPDM E/R"](#).

NG >> Replace BCM. Refer to [BCS-19, "Removal and Installation of BCM"](#).

DATA MONITOR			
MONITOR			
TAIL&CLR REQ		ON	
		RECORD	
MODE	BACK	LIGHT	COPY

SKIA5958E

# PARKING, LICENSE PLATE AND TAIL LAMPS

## 4. CHECK INPUT SIGNAL

④ With CONSULT-II

1. Turn ignition switch OFF.
2. Disconnect front combination lamp, license plate lamp and rear combination lamp connectors.
3. Turn ignition switch ON.
4. Select "IPDM E/R" on CONSULT-II, and select "ACTIVE TEST" on "SELECT DIAG MODE" screen.
5. Select "TAIL LAMP" on "SELECT TEST ITEM" screen.
6. Touch "ON" on "ACTIVE TEST" screen.
7. When tail lamp is operating, check voltage between front combination lamp, license plate lamp, rear combination lamp harness connector and ground.

⊗ Without CONSULT-II

1. Turn ignition switch OFF.
2. Start auto active test. Refer to [PG-22, "Auto Active Test"](#).
3. When tail lamp is operating, check voltage between front combination lamp, license plate lamp, rear combination lamp harness connector and ground.

Terminals			Voltage	
Front combination lamp (+)		(-)		
Connector	Terminal (Wire color)			
RH	E107	6 (R/L)	Ground	Battery voltage
LH	E11			

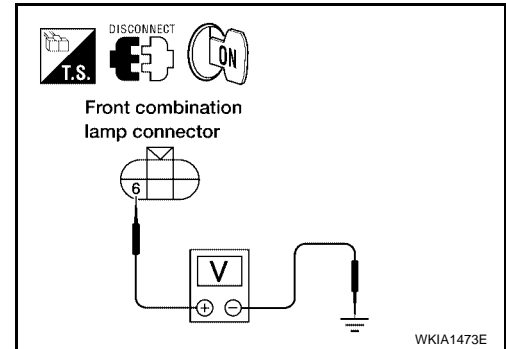

Terminals			Voltage
License plate lamps (+)		(-)	
Connector	Terminal (Wire color)		
C12	+ (R/L)	Ground	Battery voltage

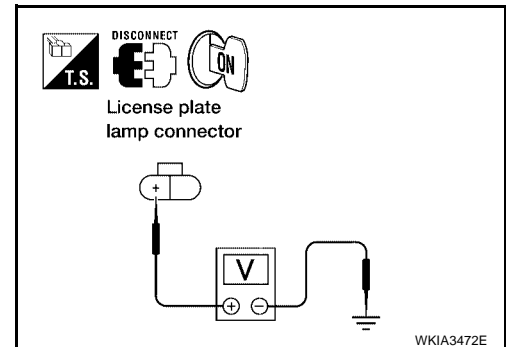

Terminals			Voltage	
Rear combination lamp (+)		(-)		
Connector	Terminal (Wire color)			
RH	C14	6 (R/L)	Ground	Battery voltage
LH	C13			

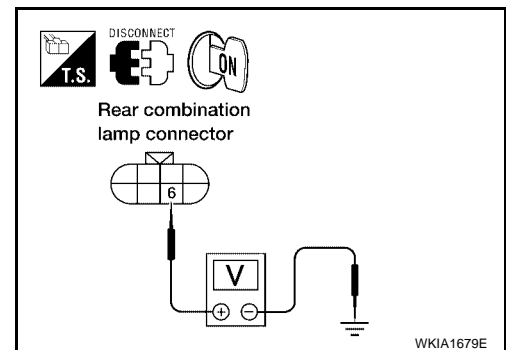

OK or NG

- OK >> GO TO 6.  
 NG >> GO TO 5.

# PARKING, LICENSE PLATE AND TAIL LAMPS

## 5. CHECK PARKING, LICENSE PLATE AND TAIL LAMP CIRCUIT

1. Turn ignition switch OFF.
2. Disconnect IPDM E/R connector.
3. Check continuity between IPDM E/R harness connector and front combination lamp harness connector.

Terminals					Continuity
IPDM E/R		Front combination lamp			
Connector	Terminal (Wire color)	Connector	Terminal (Wire color)		
E124	57 (R/L)	RH	E107	6 (R/L)	Yes
		LH	E11		

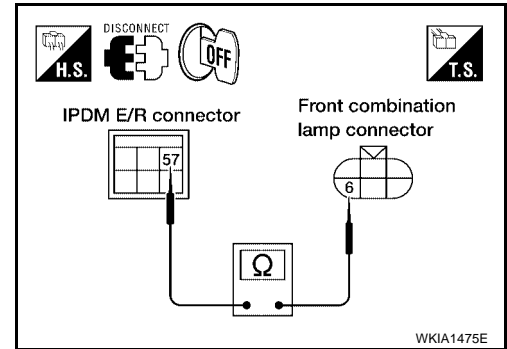

4. Check continuity between IPDM E/R harness connector and license plate lamps harness connector.

Terminals					Continuity
IPDM E/R		License plate lamps			
Connector	Terminal (Wire color)	Connector	Terminal (Wire color)		
E124	57 (R/L)	C12	+ (R/L)		Yes

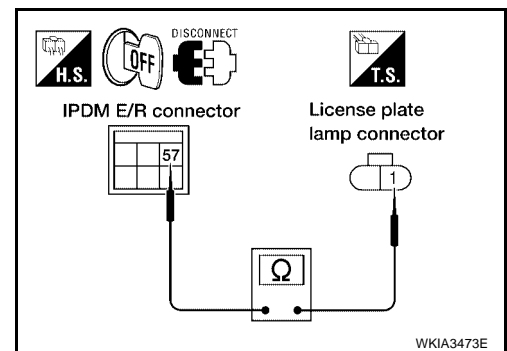

5. Check continuity between IPDM E/R harness connector and rear combination lamp harness connector.

Terminals					Continuity
IPDM E/R		Rear combination lamp			
Connector	Terminal (Wire color)	Connector	Terminal (Wire color)		
E124	57 (R/L)	RH	C14	6 (R/L)	Yes
		LH	C13		

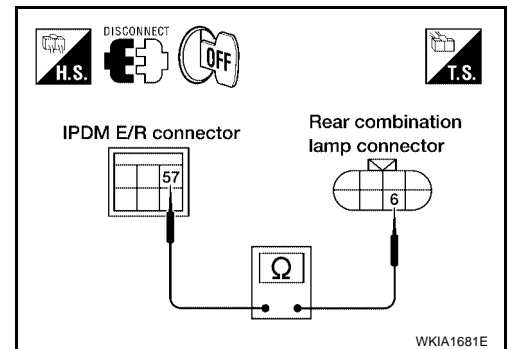

OK or NG

- OK >> Replace IPDM E/R. Refer to [PG-28, "Removal and Installation of IPDM E/R"](#).
- NG >> Repair harness or connector.

# PARKING, LICENSE PLATE AND TAIL LAMPS

## 6. CHECK GROUND

1. Check continuity between front combination lamp harness connector and ground.

Terminals				Continuity
Front combination lamp		Terminal (Wire color)	Ground	
Connector				
RH	E107	4 (B)	Ground	Yes
LH	E11			

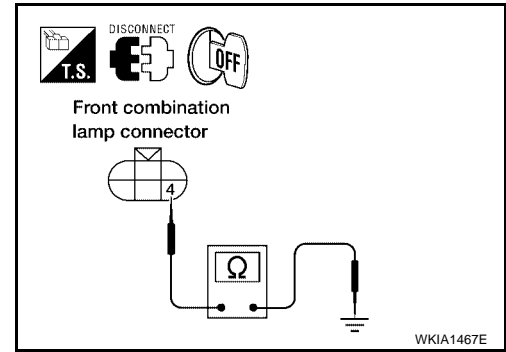

2. Check continuity between license plate lamps harness connector and ground.

Terminals				Continuity
License plate lamps		Terminal (Wire color)	Ground	
Connector				
C12		- (B)	Ground	Yes

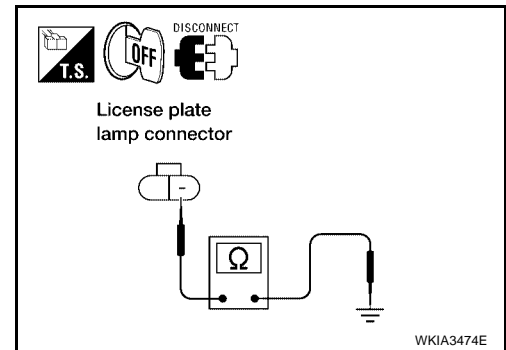

3. Check continuity between rear combination lamp harness connector and ground.

Terminals				Continuity
Rear combination lamp		Terminal (Wire color)	Ground	
Connector				
RH	C14	1 (B)	Ground	Yes
LH	C13			

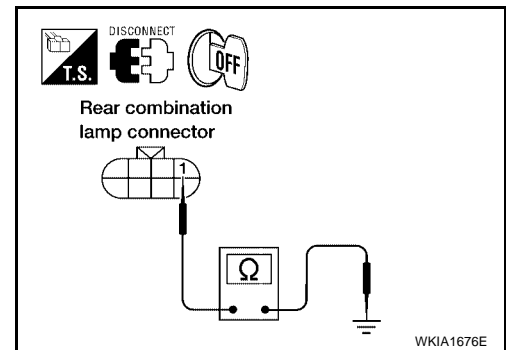

OK or NG

- OK >> Check bulbs.
- NG >> Repair harness or connector.

## Parking, License Plate and Tail Lamps Do Not Turn OFF (After Approx. 10 Minutes)

EKS00ABU

### 1. CHECK IPDM E/R

1. Turn ignition switch ON. Turn the combination switch (lighting switch) to the OFF position. Turn ignition switch OFF.
2. Verify that the parking, license plate, and tail lamps turn on and off after approximately 10 minutes.

OK or NG

- OK >> Ignition relay malfunction. Refer to [PG-17, "Function of Detecting Ignition Relay Malfunction"](#).
- NG >> Inspection End.

# PARKING, LICENSE PLATE AND TAIL LAMPS

---

## Front Parking Lamp BULB REPLACEMENT

EKS00ABV

For bulb replacement, refer to [LT-30, "FRONT TURN SIGNAL/PARKING LAMP"](#) .

## Tail Lamp BULB REPLACEMENT

EKS00ABW

For bulb replacement, refer to [LT-118, "Bulb Replacement"](#) .

A

B

C

D

E

F

G

H

I

J

LT

L

M

# REAR COMBINATION LAMP

## REAR COMBINATION LAMP

PF2:26554

### Bulb Replacement

EKS00ABX

1. Remove rear combination lamp mounting bolts.
2. Pull rear combination lamp to remove from the vehicle.
3. Turn bulb socket counterclockwise and unlock it.
4. Remove bulb.

Installation is in the reverse order of removal.

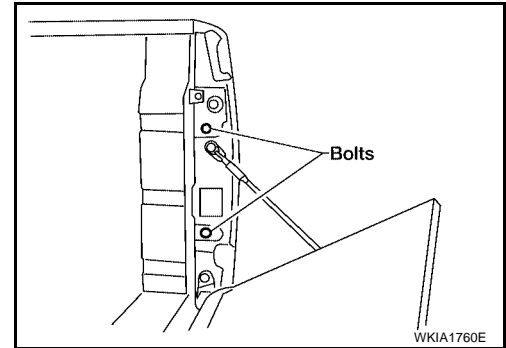

### Removal and Installation

EKS00ABY

1. Remove rear combination lamp mounting bolts.
2. Pull rear combination lamp to remove from the vehicle.
3. Disconnect rear combination lamp connector.

Installation is in the reverse order of removal.

**Rear combination lamp mounting bolts : 14.2 N-m (1.4 kg-m, 126 in-lb)**

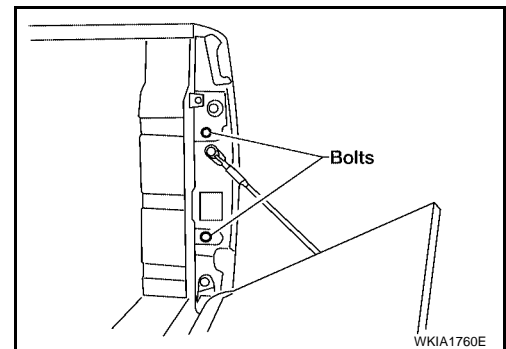

## TRAILER TOW

### Component Parts and Harness Connector Location

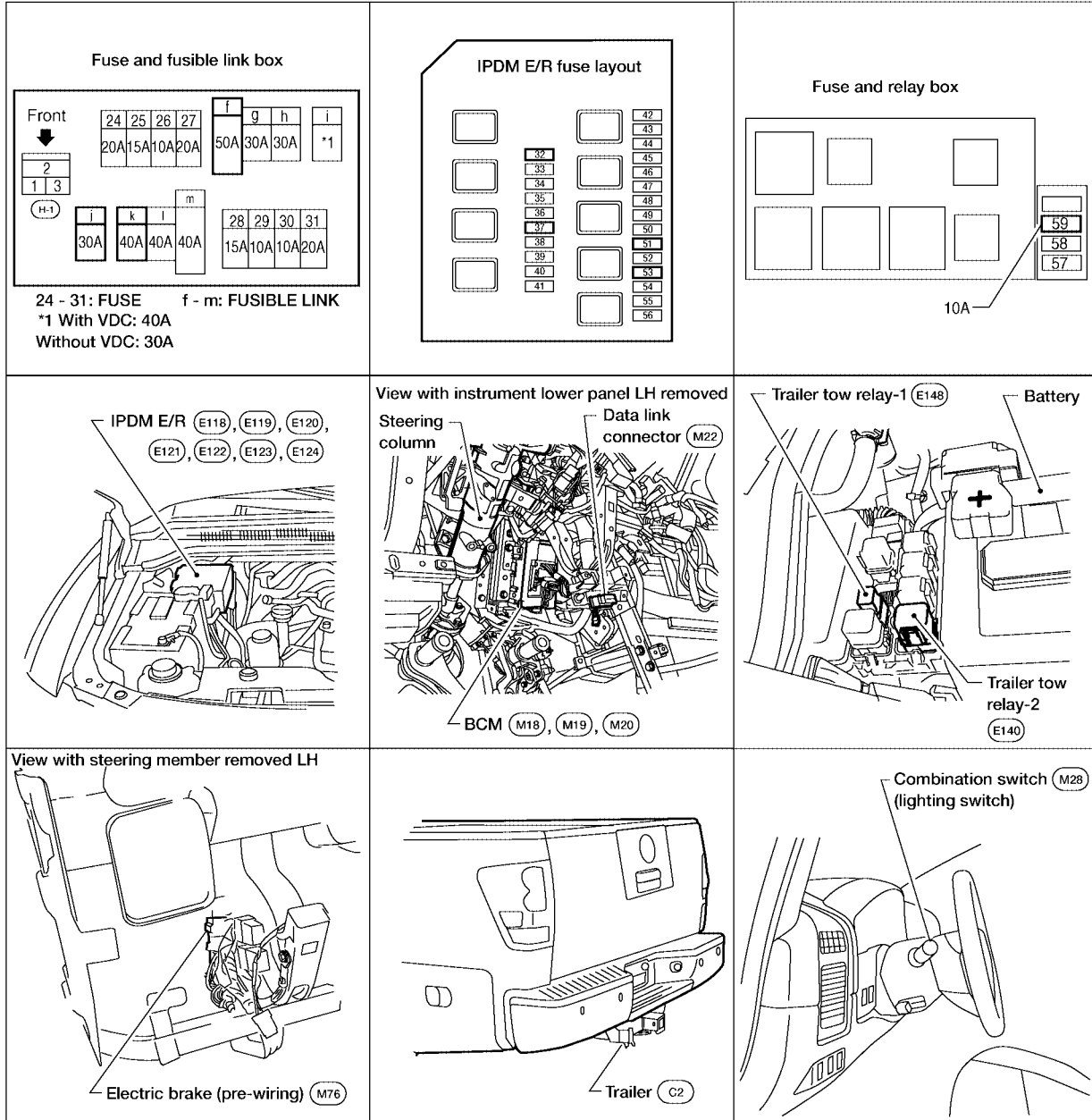

WKIA3585E

EKS00AC0

## System Description

Power is supplied at all times

- to ignition relay, located in the IPDM E/R (intelligent power distribution module engine room), and
- through 50A fusible link (letter f, located in the fuse and fusible link box)
- to BCM (body control module) terminal 70, and
- through 10A fuse (No. 32, located in the IPDM E/R)
- through IPDM E/R terminal 61
- to trailer tow relay 1 terminal 3, and
- through 20A fuse (No. 53, located in the IPDM E/R)
- to CPU in the IPDM E/R, and

A  
B  
C  
D  
E  
F  
G  
H  
I  
J  
LT  
L  
M

# TRAILER TOW

---

- to tail lamp relay, located in the IPDM E/R, and
- through 30A fusible link (letter **j** , located in the fuse and fusible link box)
- to trailer tow relay 2 terminals 3 and 6, and
- through 40A fusible link (letter **k** , located in the fuse and fusible link box)
- to electric brake (pre-wiring) terminal 5.

With the ignition switch in the ON or START position, power is supplied

- to ignition relay, located in the IPDM E/R, and
- through 10A fuse (No. 59, located in the fuse and relay box)
- to BCM terminal 38, and
- through 10A fuse (No. 51, located in the IPDM E/R)
- to trailer tow relay 2 terminal 1.

Ground is supplied

- to BCM terminal 67 and
- to electric brake (pre-wiring) terminal 1
- through grounds M57, M61 and M79, and
- to IPDM E/R terminals 38 and 59
- to trailer tow relay 1 terminal 2
- to trailer tow relay 2 terminal 2, and
- to trailer connector terminal 2
- through grounds E9, E15 and E24.

## TRAILER TAIL LAMP OPERATION

The trailer tail lamps are controlled by the trailer tow relay 1.

With the lighting switch in the parking and tail lamp ON (1ST) position, AUTO position (and the auto light system is activated) or headlamp ON (2ND) position, power is supplied

- through the tail lamp relay, located in the IPDM E/R
- through 10A fuse (No. 36, located in the IPDM E/R)
- to IPDM E/R terminal 49
- to trailer tow relay 1 terminal 1.

When energized, trailer tow relay 1 supplies tail lamp power to trailer connector terminal 6.

## TRAILER TURN SIGNAL AND HAZARD LAMP OPERATION

The trailer turn signal and hazard lamps are controlled by the BCM. If either turn signal or the hazard lamps are turned on, the BCM supplies voltage to the trailer lamps to make them flash.

Left turn signal and hazard lamp output is supplied

- through BCM terminal 52
- to trailer connector terminal 1.

Right turn signal and hazard lamp output is supplied

- through BCM terminal 51
- to trailer connector terminal 4.

## TRAILER STOP LAMP OPERATION

The trailer stop lamps are controlled by the electric brake. The electric brake receives stop lamp switch signal when the brake pedal is pressed.

When the brake pedal is pressed, power is supplied

- through electric brake (pre-wiring) terminal 3
- to trailer connector terminal 3.

## TRAILER POWER SUPPLY OPERATION

The trailer power supply is controlled by the trailer tow relay 2.

When the ignition switch is in the ON or START position, power is supplied

- through 10A fuse (No. 51, located in the IPDM E/R)
- through IPDM E/R terminal 16



## TRAILER TOW

---

- to trailer tow relay 2 terminal 1.
- When energized, the trailer tow relay 2 supplies power
- through trailer tow relay 2 terminals 5 and 7
  - to trailer connector terminal 5.

A

B

C

D

E

F

G

H

I

J

**LT**

L

M

# TRAILER TOW

## Schematic

EKS00AC1

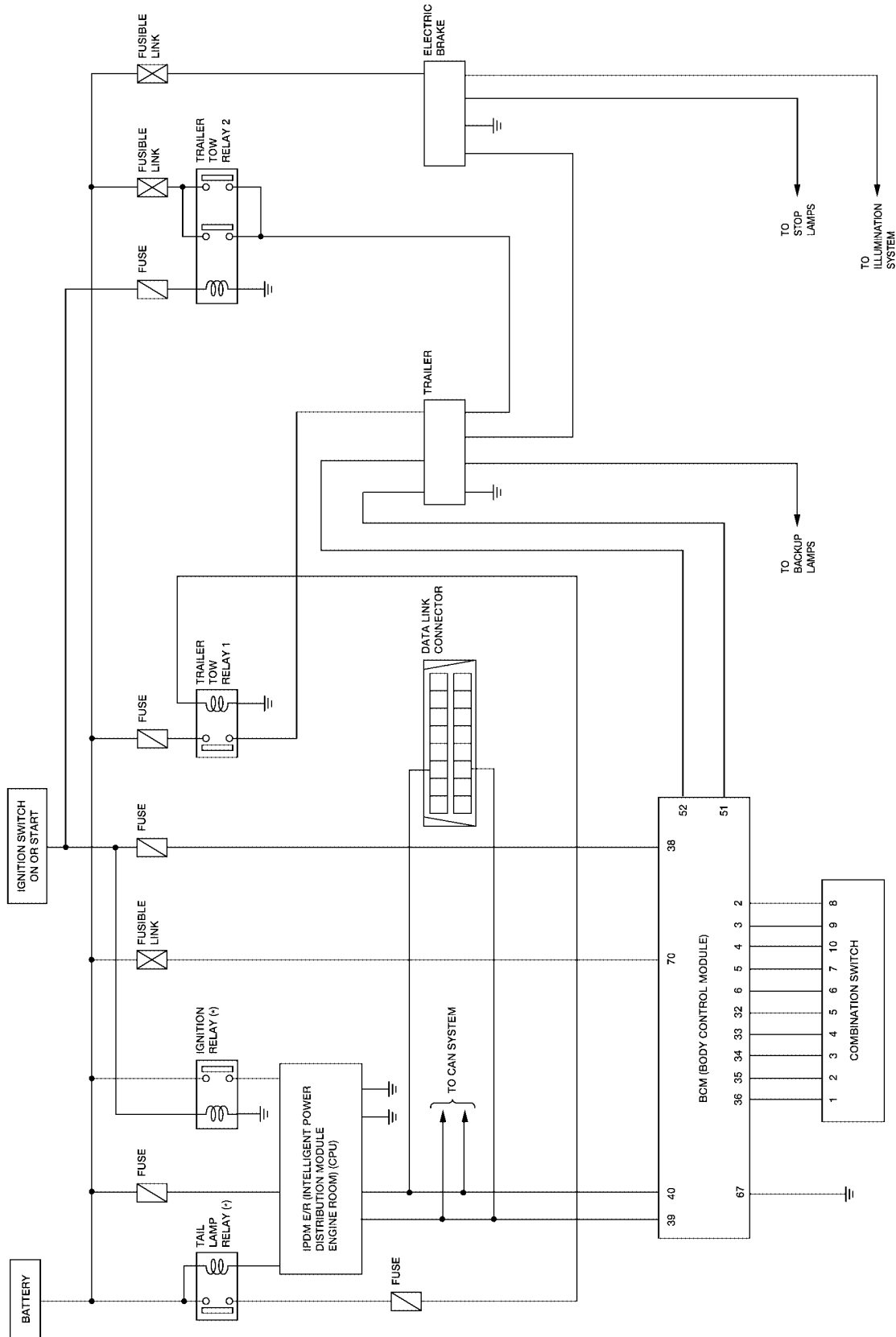

\*: THIS RELAY IS BUILT INTO THE IPDM E/R (INTELLIGENT POWER DISTRIBUTION MODULE ENGINE ROOM)

WKWA2417E

# TRAILER TOW

## Wiring Diagram — T/TOW —

EKS00AC2

### LT-T/TOW-01

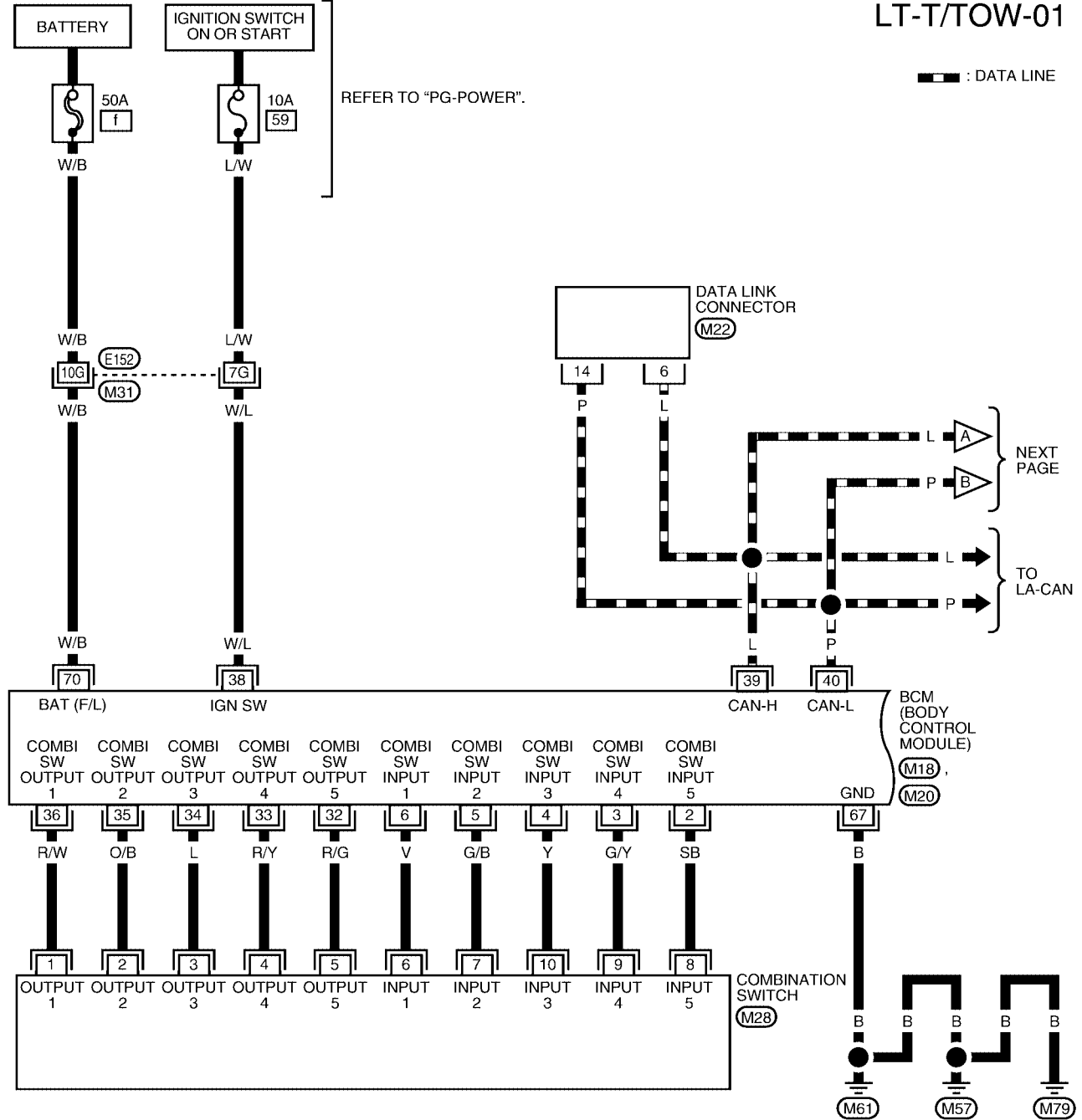

A  
B  
C  
D  
E  
F  
G  
H  
I  
J  
LT  
L  
M

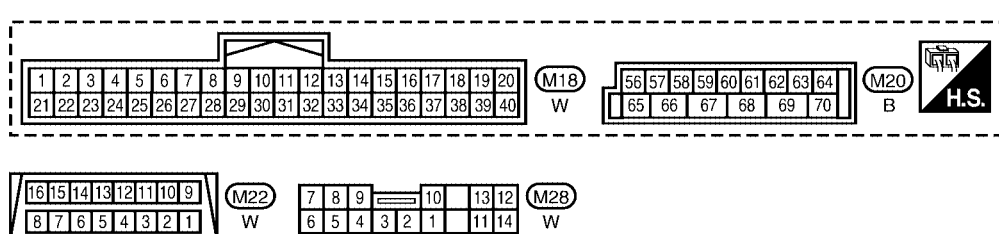

WKWA2418E

# TRAILER TOW

LT-T/TOW-02

— : DATA LINE

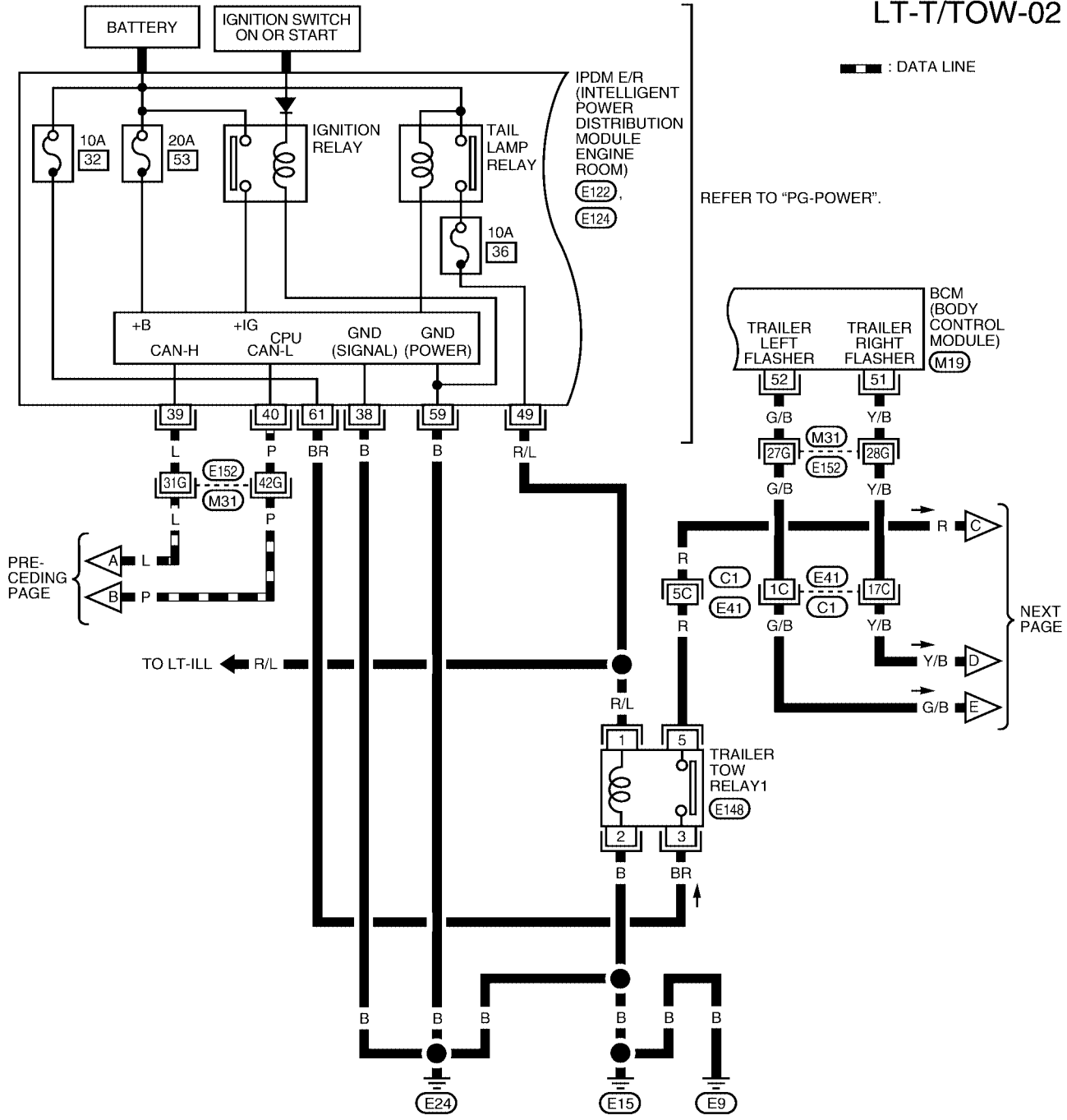

REFER TO "PG-POWER".

PRE-  
CEDING  
PAGE

NEXT  
PAGE

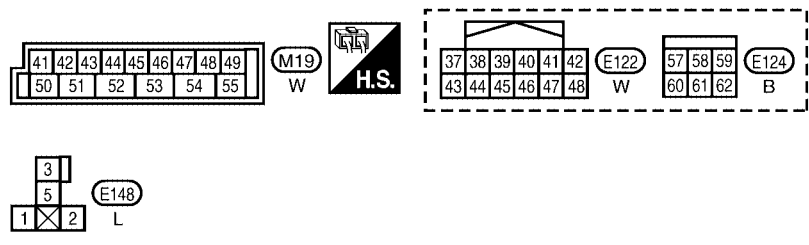

REFER TO THE FOLLOWING.  
 (M31), (C1) - SUPER  
 MULTIPLE JUNCTION (SMJ)

WKWA2419E

# TRAILER TOW

LT-T/TOW-03

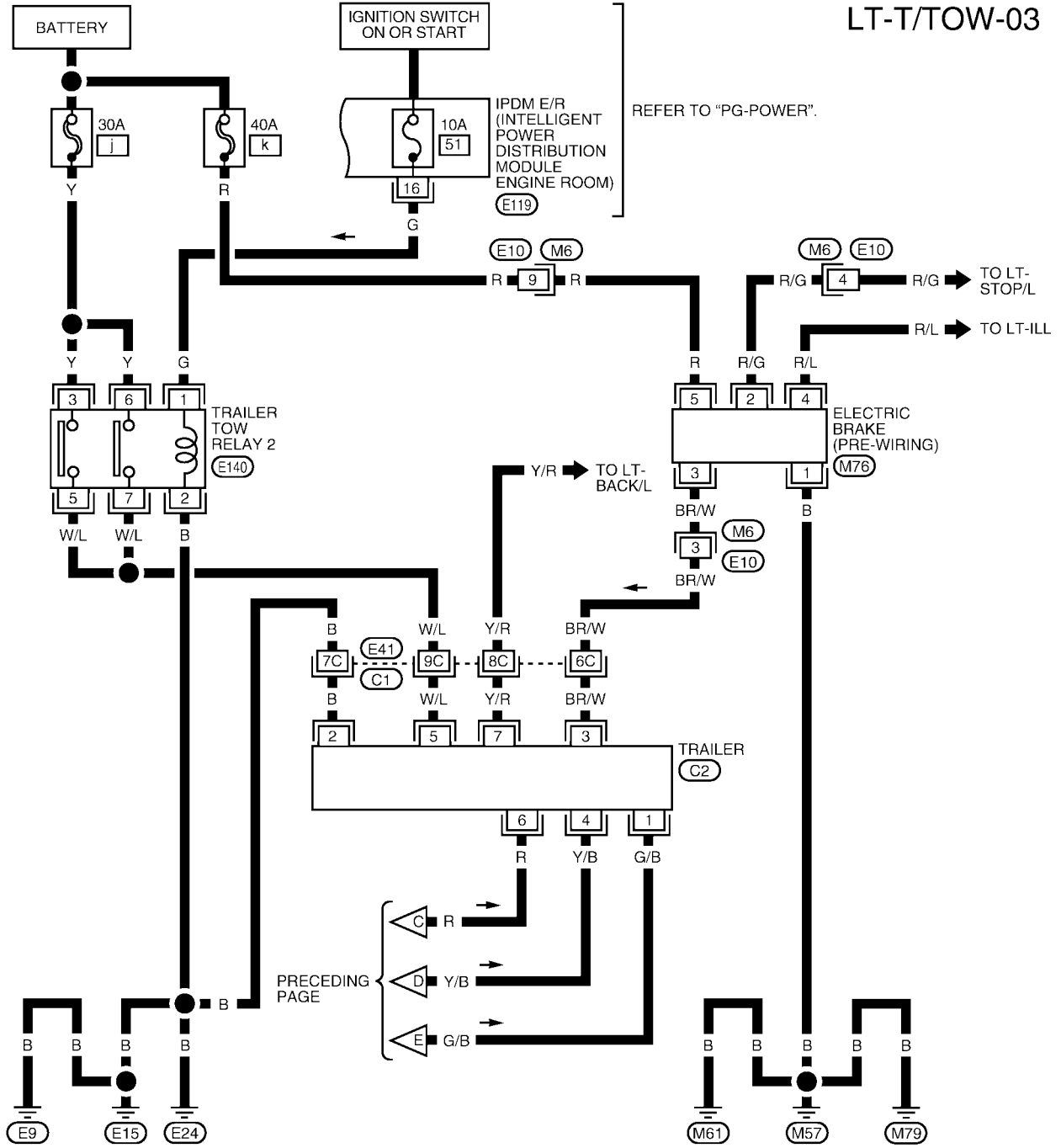

A  
B  
C  
D  
E  
F  
G  
H  
I  
J  
LT  
L  
M

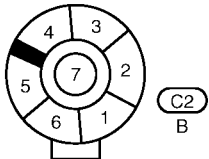
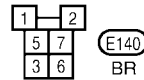
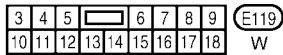

REFER TO THE FOLLOWING.  
 (C1) - SUPER MULTIPLE JUNCTION (SMJ)

---WKWA2420E---

# INTERIOR ROOM LAMP

## INTERIOR ROOM LAMP

FFP:26410

### Component Parts and Harness Connector Location

EKS00AC3

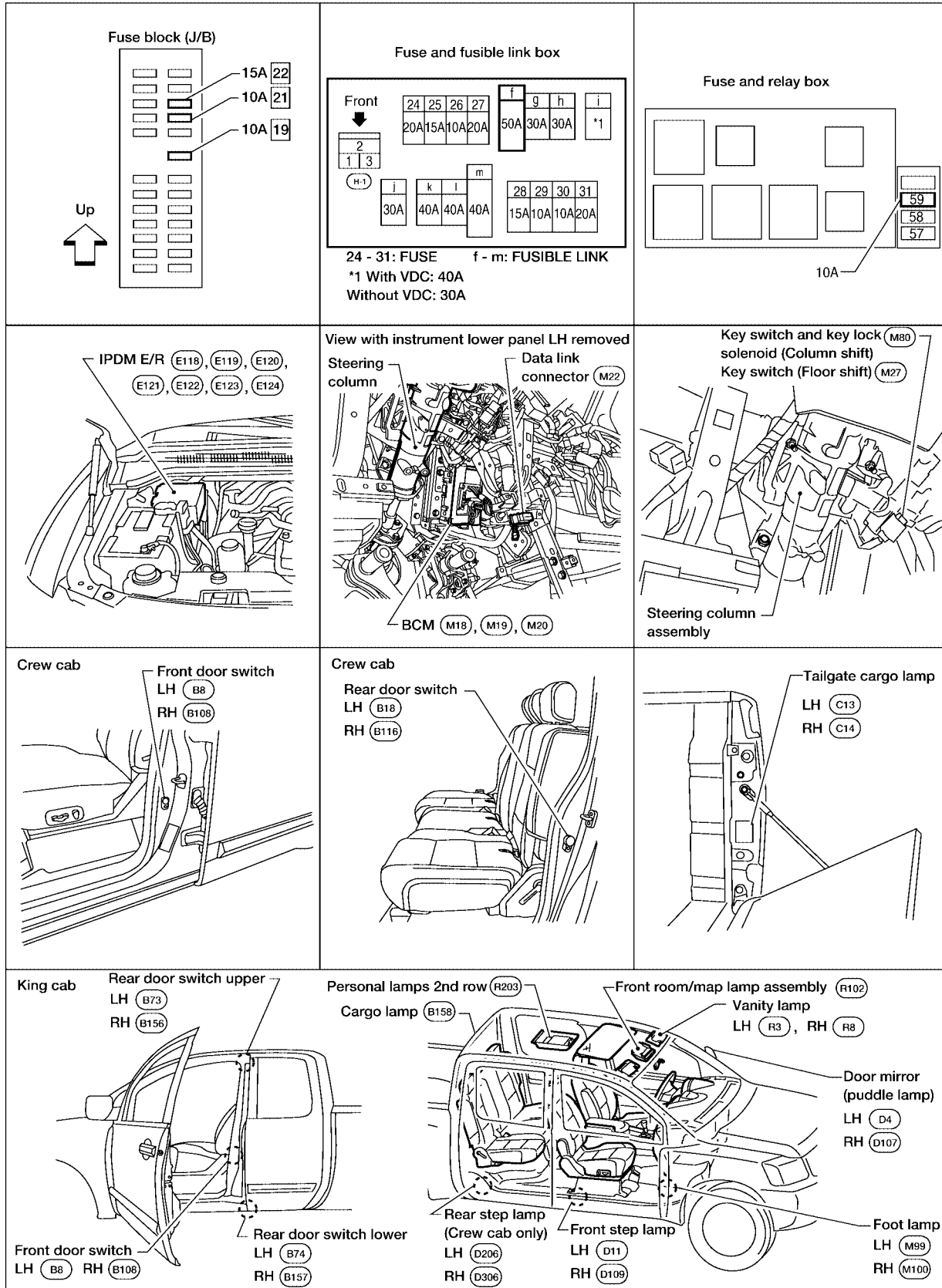

WKIA3586E

# INTERIOR ROOM LAMP

EKS00AC4

## System Description

When room lamp and personal lamp switch is in DOOR position, room lamp and personal lamp ON/OFF is controlled by timer according to signals from switches including key switch (with column shift) or key switch and key lock solenoid (with floor shift), front door switch LH side, unlock signal from keyfob, door lock and unlock switch, key cylinder lock and unlock switch, and ignition switch.

When room lamp and personal lamp turns ON, there is a gradual brightening over 1 second. When room lamp and personal lamp turns OFF, there is a gradual dimming over 1 second.

The room lamp and personal lamp timer is controlled by the BCM (body control module).

Room lamp and personal lamp timer control settings can be changed with CONSULT-II.

Step and foot lamp turns ON when front or rear doors are opened (door switch ON). Lamp turns OFF when front and rear doors are closed (all door switches OFF).

## POWER SUPPLY AND GROUND

Power is supplied at all times

- through 10A fuse [No. 19, located in the fuse block (J/B)]
- to key switch terminal 3, and
- through 15A fuse [No. 22, located in the fuse block (J/B)]
- to BCM terminal 57, and
- through 50A fusible link (letter f , located in the fuse and fusible link box)
- to BCM terminal 70, and
- through 10A fuse [No. 21, located in the fuse block (J/B)]
- to cargo lamp relay terminals 2 and 5.

When the key is inserted in key switch (with column shift) or key switch and key lock solenoid (with floor shift), power is supplied

- through the key switch (with column shift) or key switch and key lock solenoid (with floor shift) terminal 4
- to BCM terminal 37.

With the ignition switch in the ON or START position, power is supplied

- through 10A fuse (No. 59, located in the fuse and relay box)
- to BCM terminal 38.

Ground is supplied

- to BCM terminal 67
- through grounds M57, M61 and M79.

When the front door LH is opened, ground is supplied

- to BCM terminal 47
- through front door switch LH terminal 2
- through case ground of front door switch LH (crew cab) or
- through front door switch LH terminal 3 (king cab)
- through grounds B7 and B19.

When the front door RH is opened, ground is supplied

- to BCM terminal 12
- through front door switch RH terminal 2
- through case ground of front door switch RH (crew cab) or
- through front door switch RH terminal 3 (king cab)
- through grounds B117 and B132 (king cab).

When the rear door LH (crew cab) is opened, ground is supplied

- to BCM terminal 48
- through rear door switch LH terminal 2
- through case ground of rear door switch LH.

When the rear door LH (king cab) is opened, ground is supplied

- to BCM terminal 47
- through rear door switch upper LH and rear door switch lower LH terminal 1

A  
B  
C  
D  
E  
F  
G  
H  
I  
J  
L  
M

LT

# INTERIOR ROOM LAMP

---

- through rear door switch upper LH and rear door switch lower LH terminal 2
- through grounds B7 and B19.

When the rear door RH (crew cab) is opened, ground is supplied

- to BCM terminal 13
- through rear door switch RH terminal 2
- through case ground of rear door switch RH.

When the rear door RH (king cab) is opened, ground is supplied

- to BCM terminal 12
- through rear door switch upper RH and rear door switch lower RH terminal 1
- through rear door switch upper RH and rear door switch lower RH terminal 2
- through grounds B117 and B132.

When the front door LH or RH is unlocked by the door lock and unlock switch, BCM receives serial data

- to BCM terminal 22
- through main power window and door lock/unlock switch terminal 14 (crew cab) or 12 (king cab) and power window and door lock/unlock switch RH terminal 16
- through main power window and door lock/unlock switch terminal 17 (crew cab) or 15 (king cab)
- through grounds M57, M61 and M79.

When the front door LH is unlocked by the key, the BCM receives serial data

- to BCM terminal 22
- through main power window and door lock/unlock switch terminal 14 (crew cab) or 12 (king cab)
- through main power window and door lock/unlock switch terminal 6 (crew cab) or 7 (king cab)
- through front door lock assembly LH (key cylinder switch) terminal 6
- to front door lock assembly LH (key cylinder switch) terminal 5
- through grounds M57, M61 and M79.

When a signal, or combination of signals is received by the BCM, ground is supplied

- to door mirror LH and RH terminal 13 (with puddle lamps)
- to front room/map lamp assembly terminal 1 and
- to personal lamps 2nd row terminal 1 (with rear roof console)
- through front room/map lamp assembly terminal 2
- through BCM terminal 63.

With power and ground supplied, the lamps illuminate.

When the BCM receives cargo lamp switch input, ground is supplied to cargo lamp relay terminal 1, which energizes the cargo lamp relay. When this relay is energized, power is supplied

- through cargo lamp relay terminal 3
- to high-mount stop lamp (cargo lamp) terminal 3, and
- to rear combination lamp (tailgate cargo lamp) LH and RH terminal 3.

## SWITCH OPERATION

When any door switch is ON (door is opened), ground is supplied

- to front and rear (crew cab) step lamps LH and RH and foot lamp LH and RH (with foot lamps) terminal –
- through BCM terminal 62.

And power is supplied

- through BCM terminal 56
- to front and rear (crew cab) step lamps LH and RH terminal +
- to door mirror LH and RH terminal 12 (with puddle lamps)
- to front room/map lamp assembly terminal 6
- to vanity lamp LH and RH terminal 1 (with vanity lamps)
- to personal lamp 2nd row terminal 3 (with rear roof console)
- to room lamp terminal 2
- to foot lamp LH and RH terminal + (with foot lamps).



# INTERIOR ROOM LAMP

When front room/map lamp assembly switch is ON, ground is supplied

- to front room/map lamp assembly terminal 5
- through grounds M57, M61 and M79.

When vanity lamp (LH and RH) is ON, ground is supplied

- to vanity lamp (LH and RH) terminal 2
- through grounds M57, M61 and M79.

When cargo lamp switch is ON, ground is supplied

- to BCM terminal 31
- through cargo lamp switch terminal 1
- through cargo lamp switch terminal 3
- through grounds M57, M61 and M79.

## ROOM LAMP TIMER OPERATION

When lamp switch is in DOOR position, and when all conditions below are met, BCM performs timer control (maximum 30 seconds) for interior room lamp and map lamp ON/OFF.

Power is supplied

- through 10A fuse [No. 19, located in the fuse block (J/B)]
- to key switch (with column shift) or key switch and key lock solenoid (with floor shift) terminal 3.

Key is removed from key switch (with column shift) or key switch and key lock solenoid (with floor shift) (key switch OFF), power will not be supplied to BCM terminal 37.

Serial data is supplied

- to BCM terminal 22
- through main power window and door lock/unlock switch terminal 14 (crew cab) or 12 (king cab).

At the time that front door LH is opened, BCM detects that front door LH is unlocked. It determines that interior room lamp and map lamp timer operation conditions are met, and turns the interior room lamps ON for 30 seconds.

Key is in key switch (with column shift) or key switch and key lock solenoid (with floor shift) (key switch ON), power is supplied

- through key switch (with column shift) or key switch and key lock solenoid (with floor shift) terminal 4
- to BCM terminal 37.

When key is removed from key switch (with column shift) or key switch and key lock solenoid (with floor shift) (key switch OFF), power supply to BCM terminal 37 is terminated. BCM detects that key has been removed, determines that interior room lamp and map lamp timer conditions are met, and turns the interior room lamps ON for 30 seconds.

When front door LH opens → closes, and the key is not inserted in the key switch (with column shift) or key switch and key lock solenoid (with floor shift) (key switch OFF), BCM terminal 47 changes between 0V (door open) → 12V (door closed). The BCM determines that conditions for interior room lamp operation are met and turns the interior room lamp ON for 30 seconds.

Timer control is canceled under the following conditions.

- Front door LH is locked [when locked by keyfob, main power window and door lock/unlock switch or front door lock assembly LH (key cylinder switch)]
- Front door LH is opened (front door switch LH turns ON)
- Ignition switch ON.

## INTERIOR LAMP BATTERY SAVER CONTROL

If interior lamp is left ON, it will not be turned off even when door is closed.

BCM turns off interior lamp automatically to save battery 30 minutes after ignition switch is turned off.

BCM controls interior lamps listed below:

- Room lamp
- Vanity lamps
- Front room/map lamp assembly
- Personal lamp 2nd row
- Step lamps
- Puddle lamps

A  
B  
C  
D  
E  
F  
G  
H  
I  
J  
LT  
L  
M

## INTERIOR ROOM LAMP

---

- Foot lamps

After lamps turn OFF by the battery saver system, the lamps illuminate again when

- signal received from keyfob, or main power window and door lock/unlock switch or front door lock assembly LH (key cylinder switch) is locked or unlocked
- door is opened or closed
- key is removed from key switch (with column shift) or key switch and key lock solenoid (with floor shift) or inserted in key switch (with column shift) or key switch and key lock solenoid (with floor shift).

Interior lamp battery saver control period can be changed by the function setting of CONSULT-II.

# INTERIOR ROOM LAMP

## Schematic

EKS00AC5

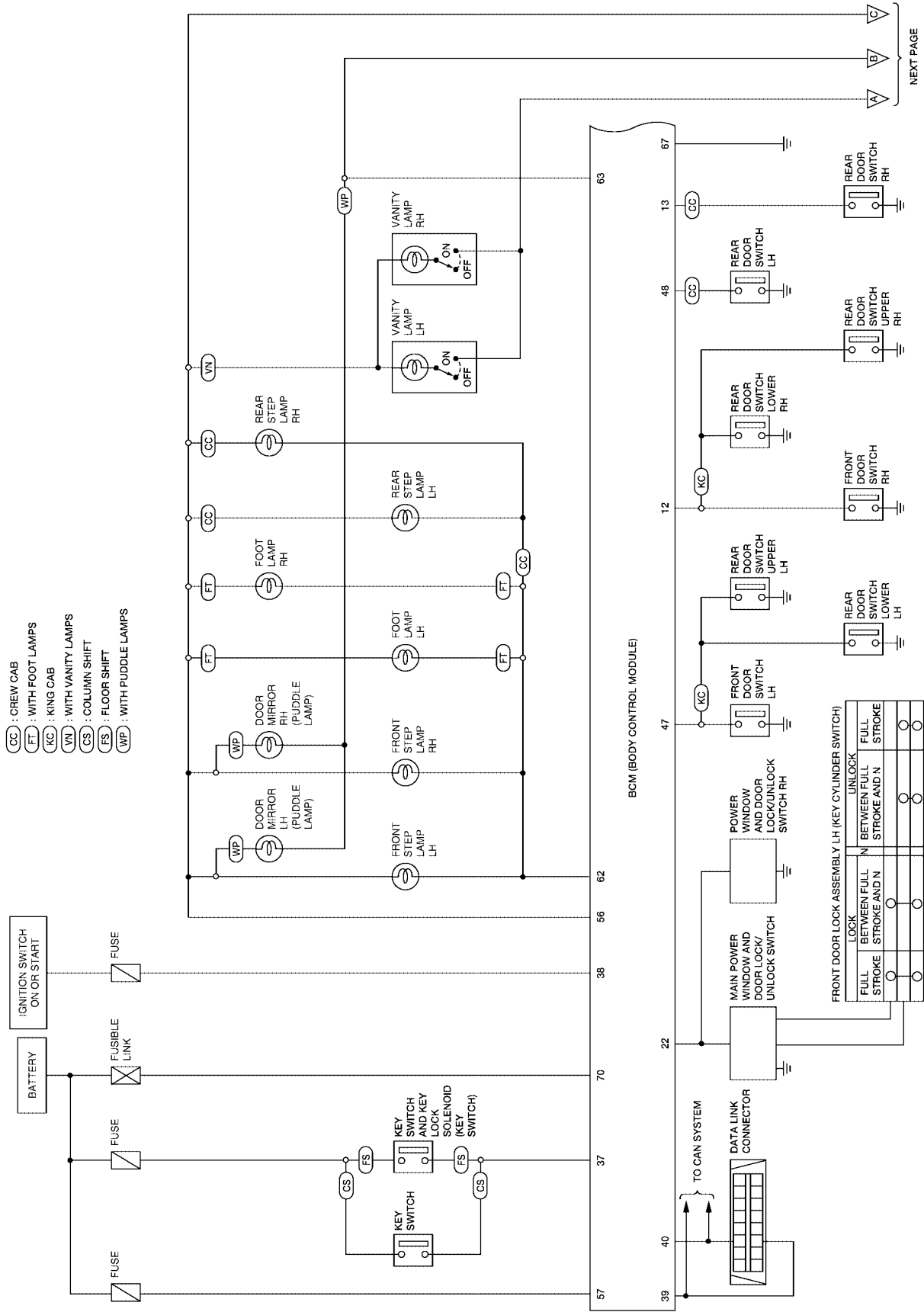

A  
B  
C  
D  
E  
F  
G  
H  
I  
J  
K  
L  
M

LT

# INTERIOR ROOM LAMP

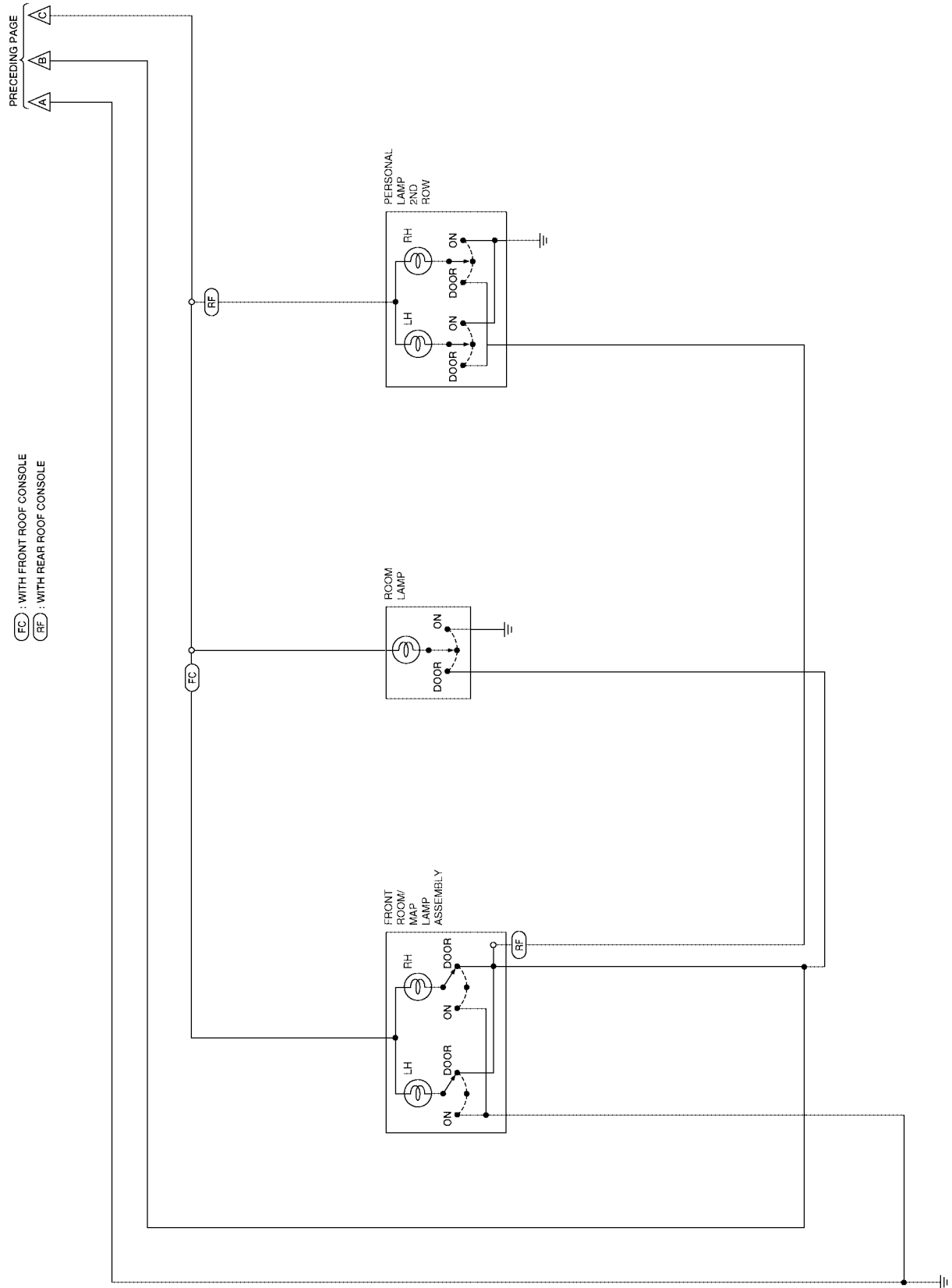

WKWA1563E

# INTERIOR ROOM LAMP

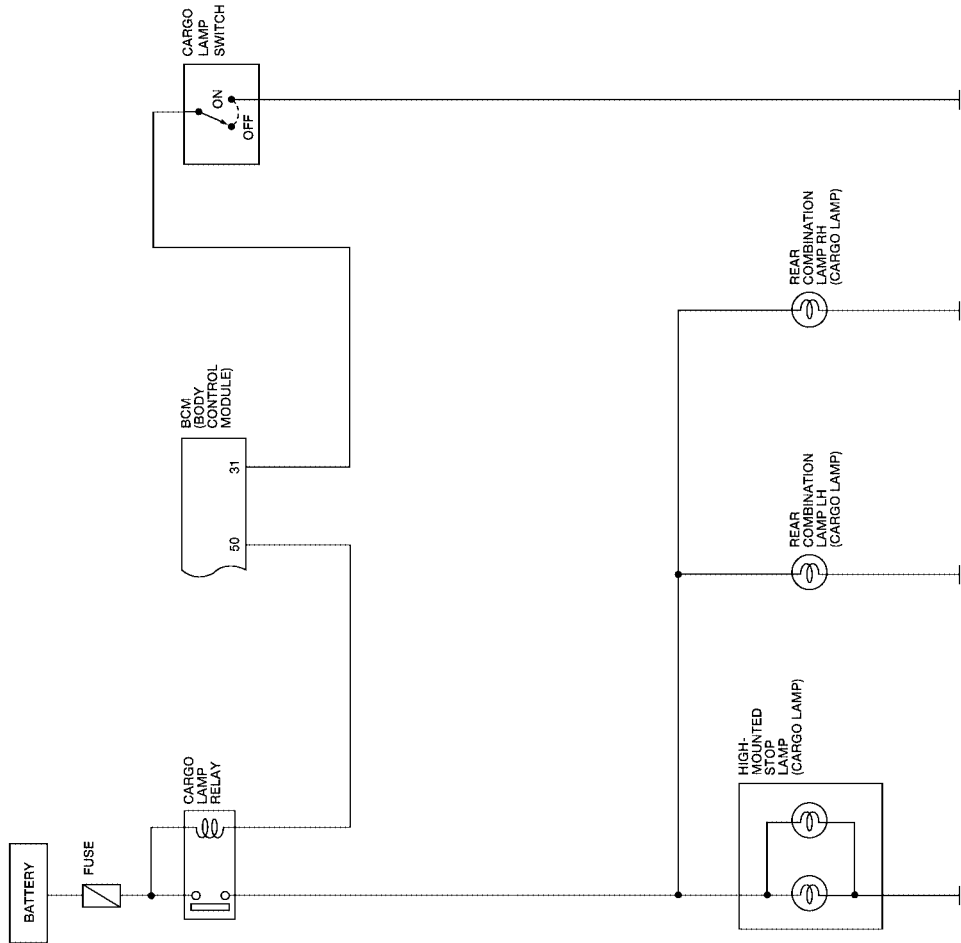

A

B

C

D

E

F

G

H

I

J

**LT**

L

M

LKWA0285E

# INTERIOR ROOM LAMP

## Wiring Diagram — INT/L —

EKS00AC6

LT-INT/L-01

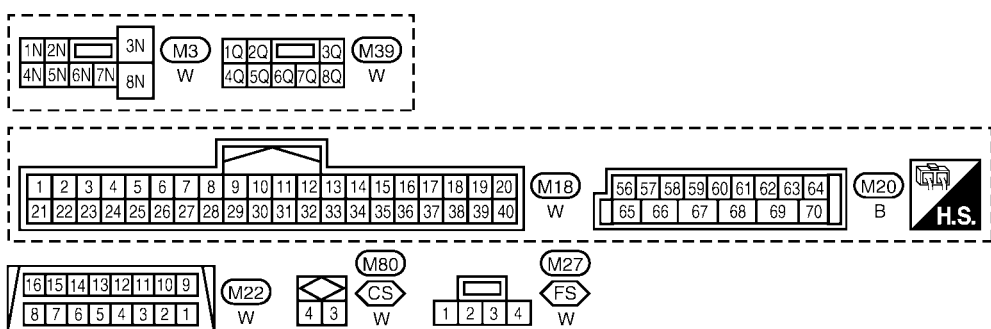
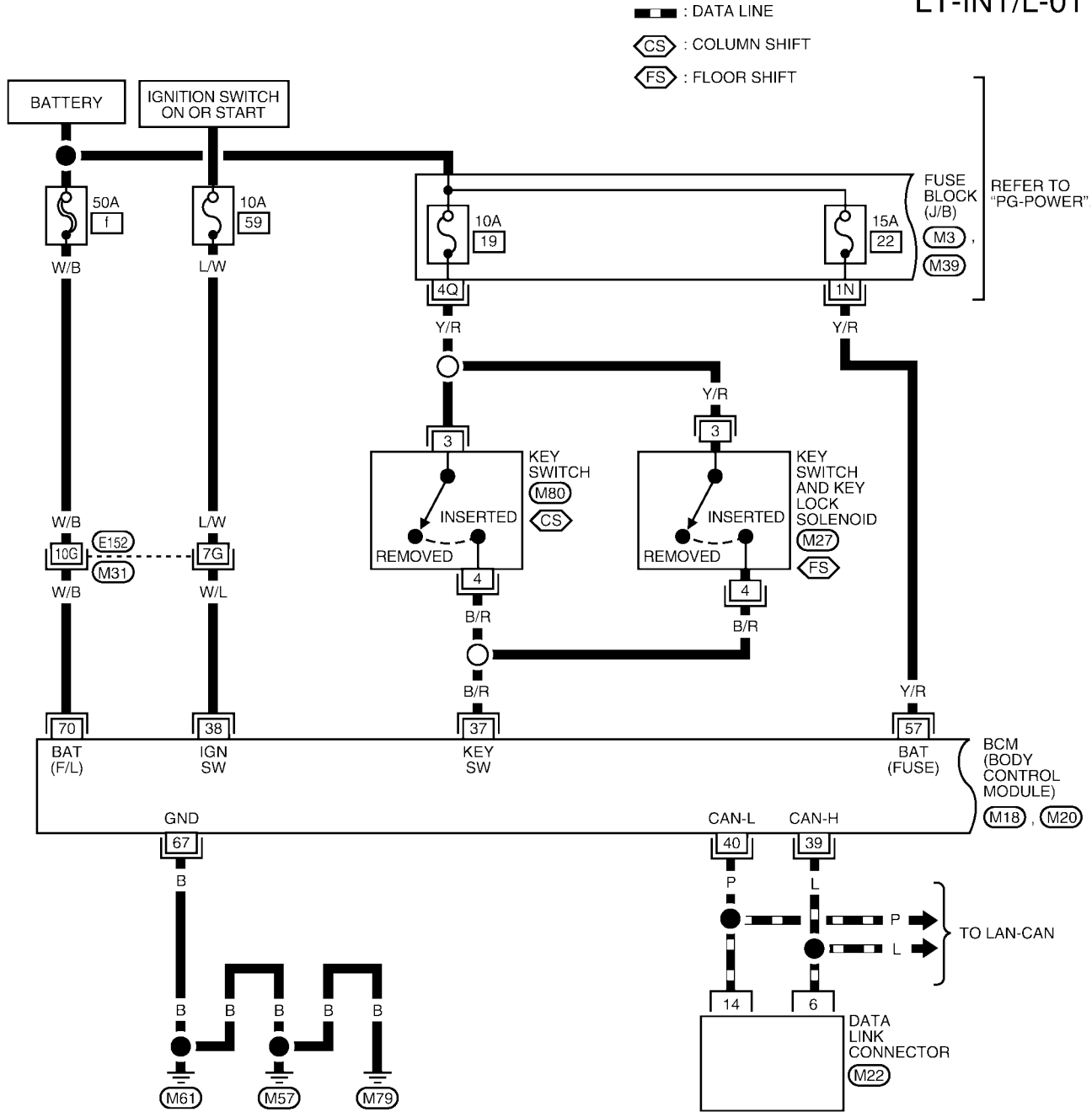

REFER TO THE FOLLOWING.  
 M31 - SUPER MULTIPLE JUNCTION (SMJ)

WKWA2448E

# INTERIOR ROOM LAMP

LT-INT/L-02

CC : CREW CAB  
KC : KING CAB

BCM  
(BODY CONTROL MODULE)

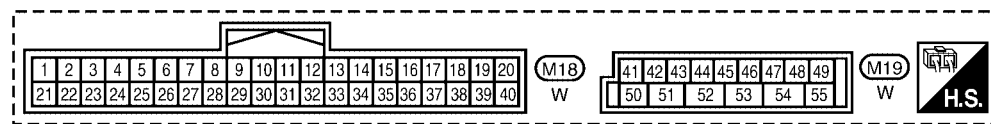
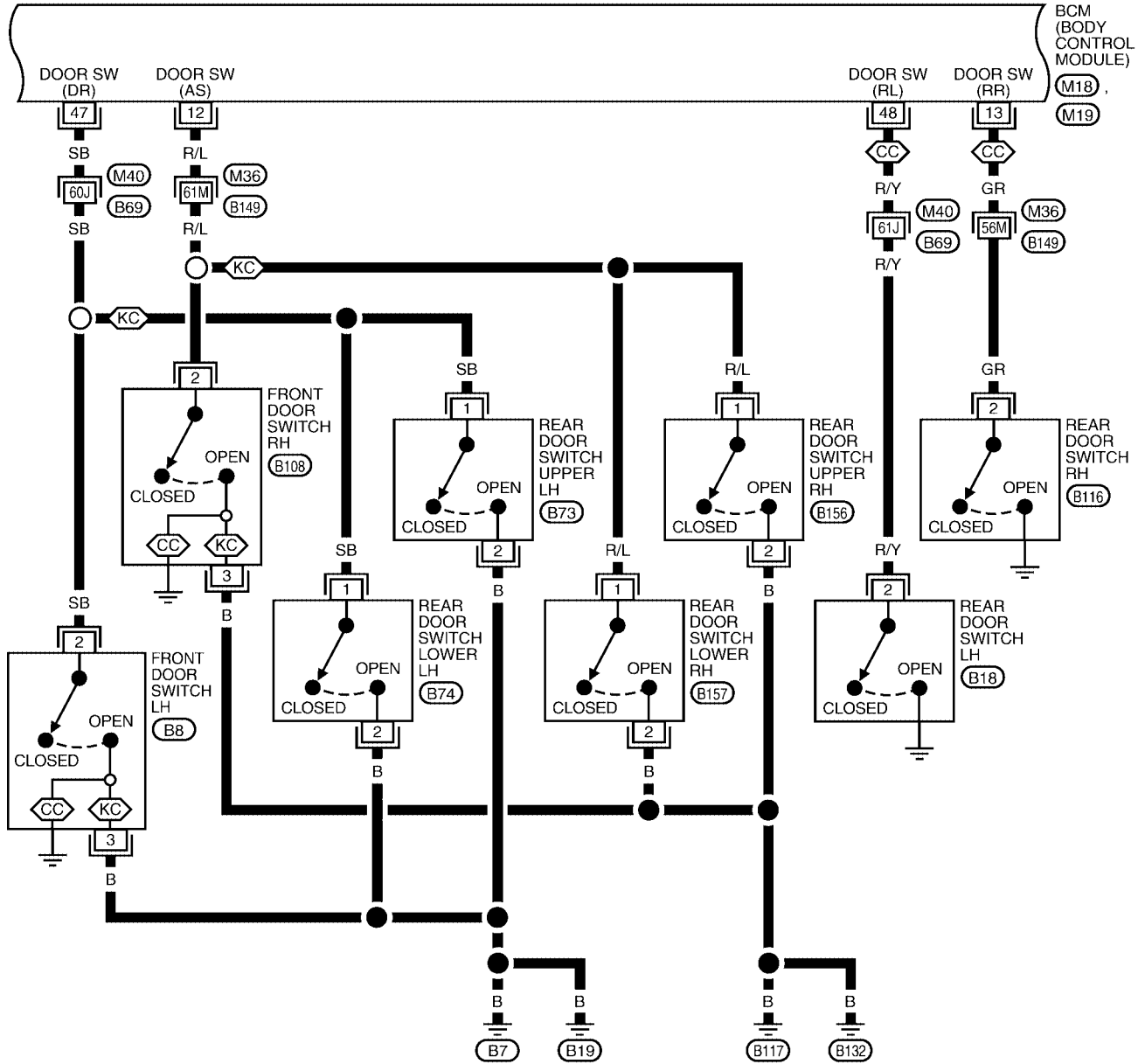

REFER TO THE FOLLOWING.  
(M36), (M40) - SUPER  
MULTIPLE JUNCTION (SMJ)

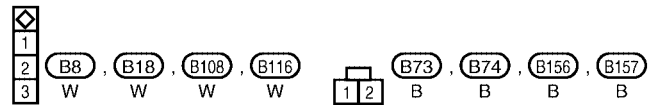

LKWA0286E

# INTERIOR ROOM LAMP

LT-INT/L-03

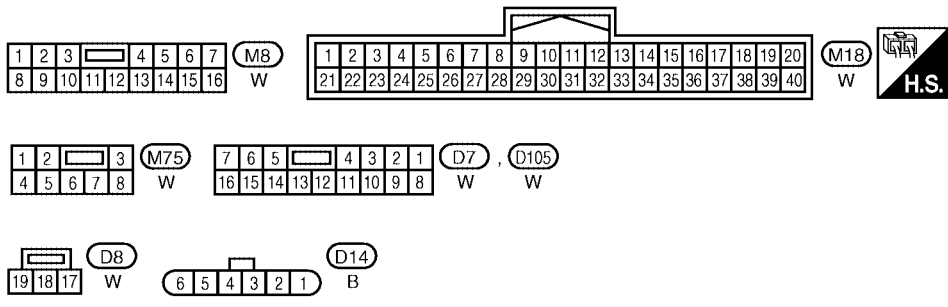
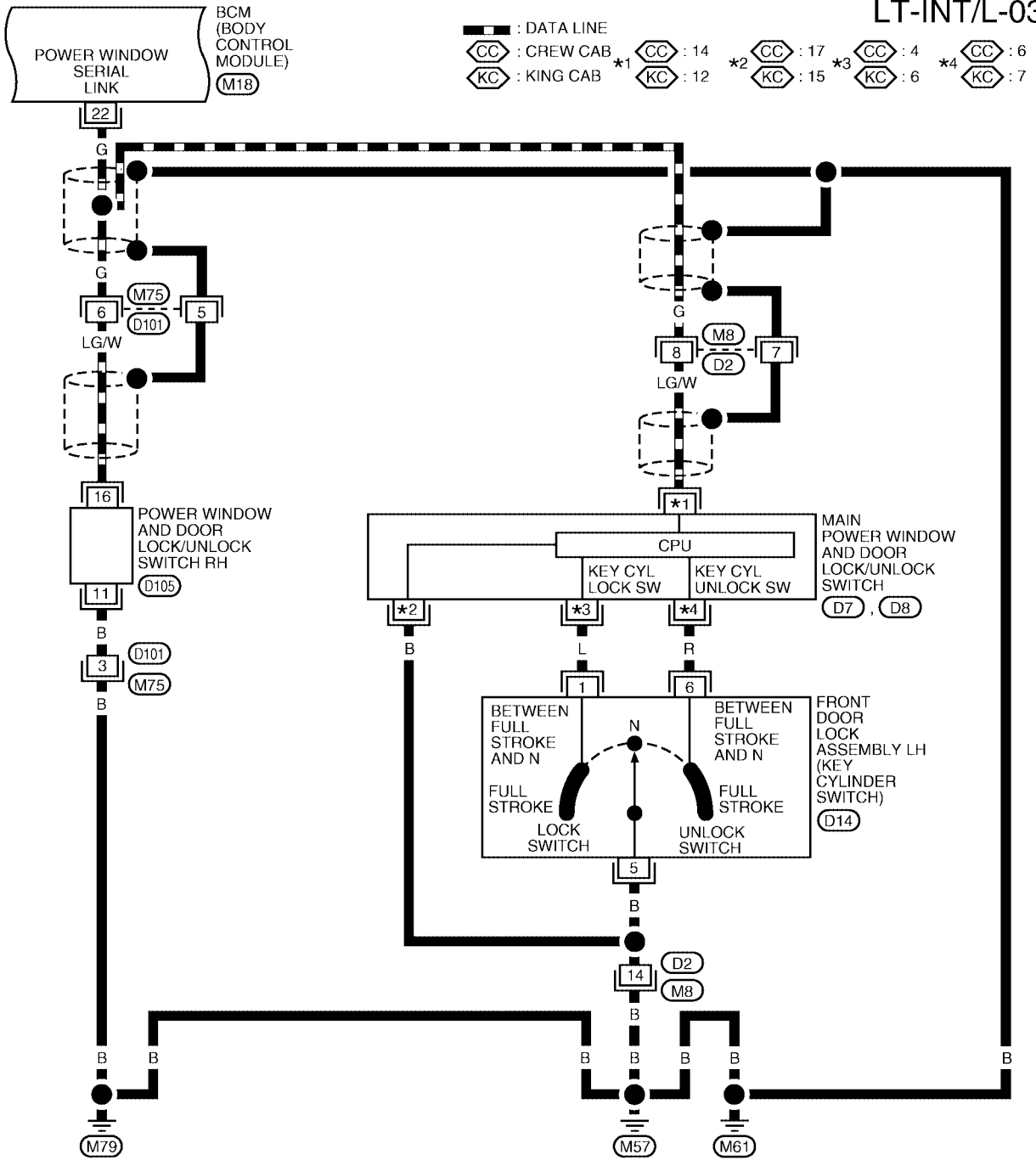

WKWA1505E



# INTERIOR ROOM LAMP

LT-INT/L-04

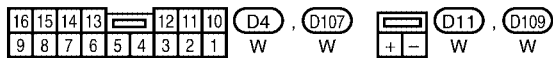
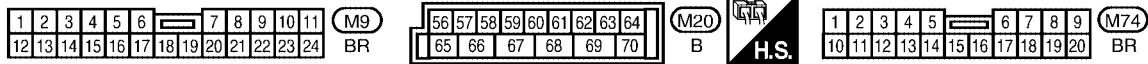
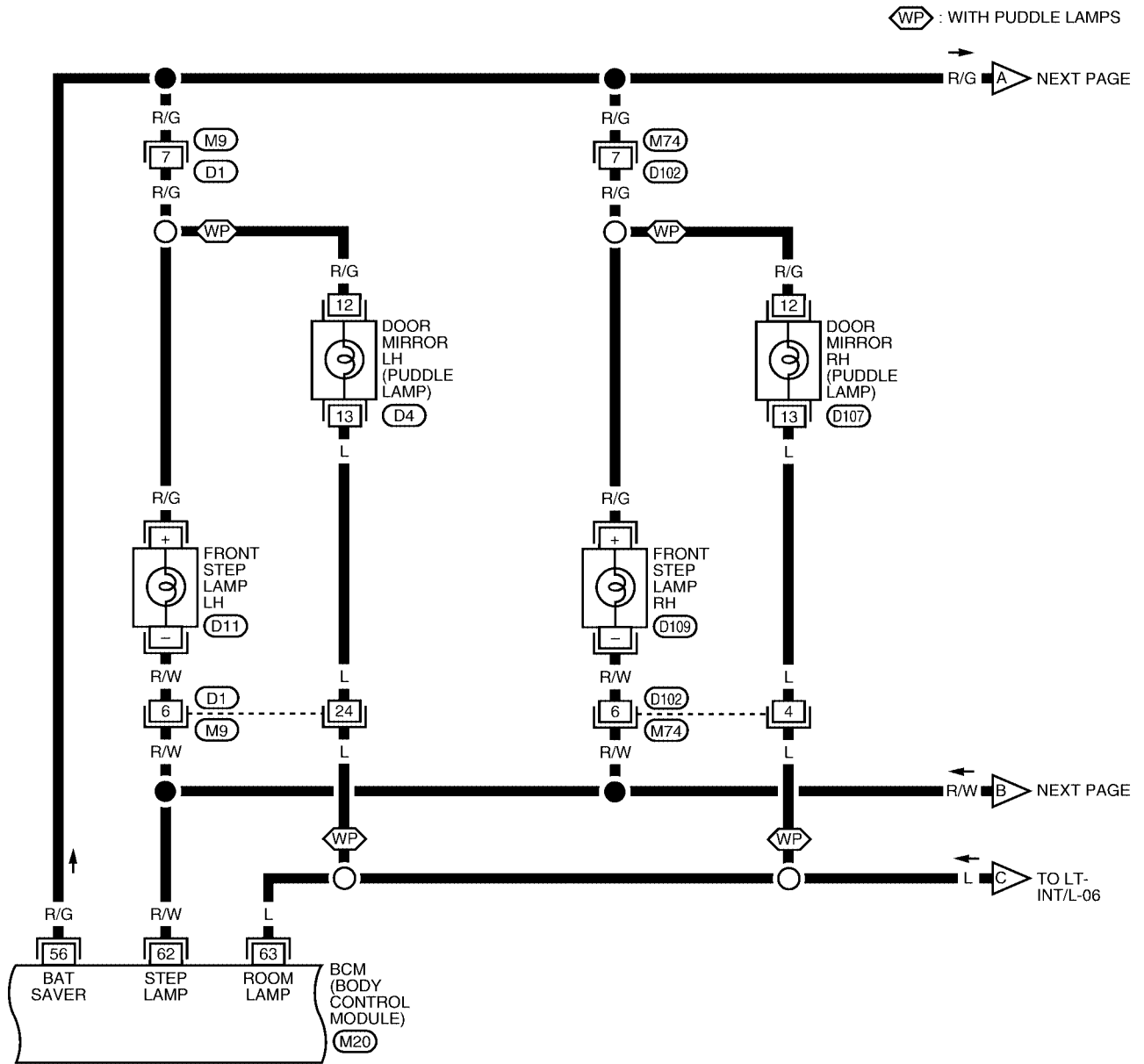

WKWA2449E

# INTERIOR ROOM LAMP

LT-INT/L-05

CC : CREW CAB  
 FT : WITH FOOT LAMPS

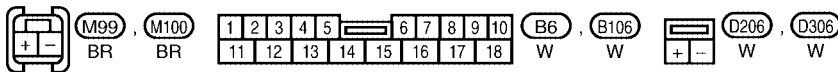
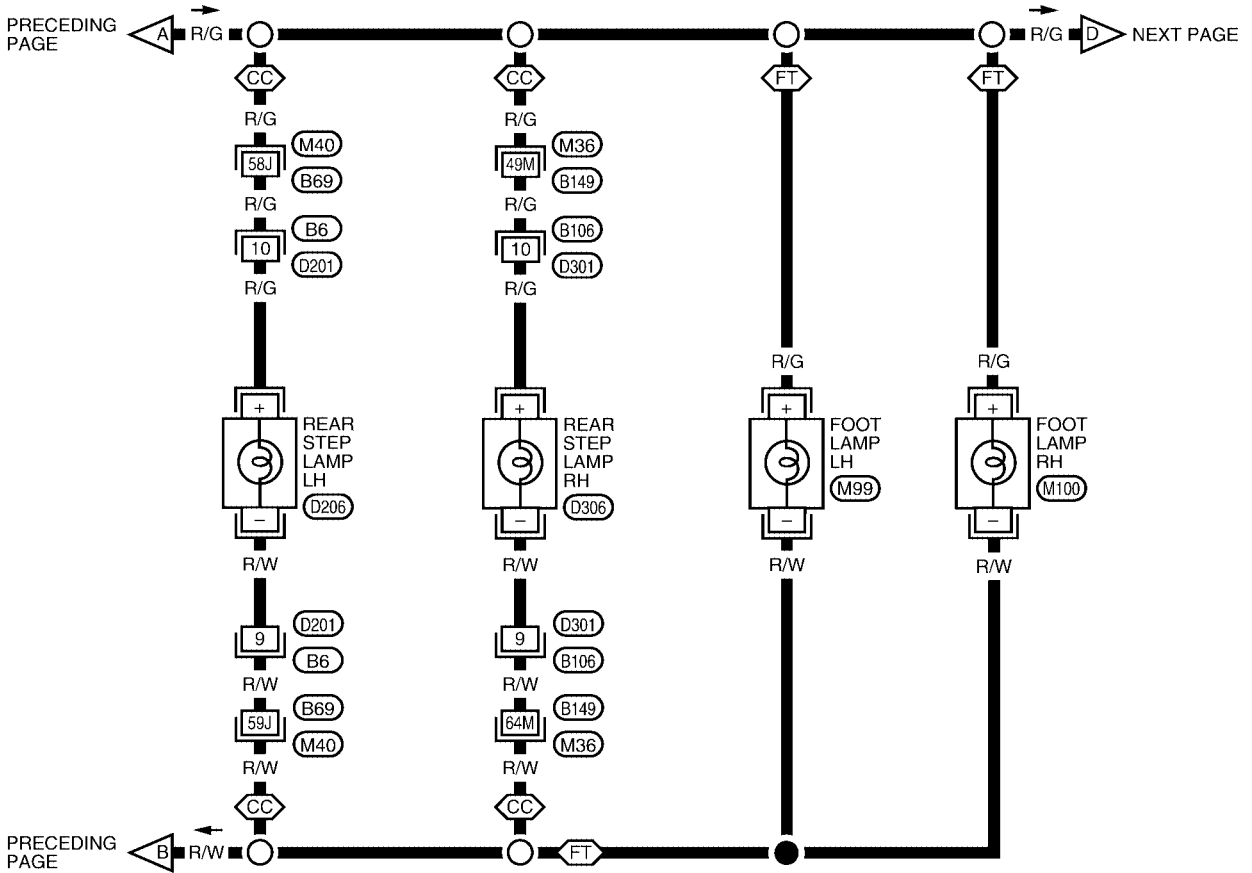



REFER TO THE FOLLOWING.  
 (M36), (M40) - SUPER  
 MULTIPLE JUNCTION (SMJ)

WKWA2450E

# INTERIOR ROOM LAMP

LT-INT/L-06

-  : WITH FRONT ROOF CONSOLE
-  : WITH REAR ROOF CONSOLE
-  : WITH VANITY LAMPS

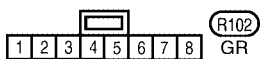
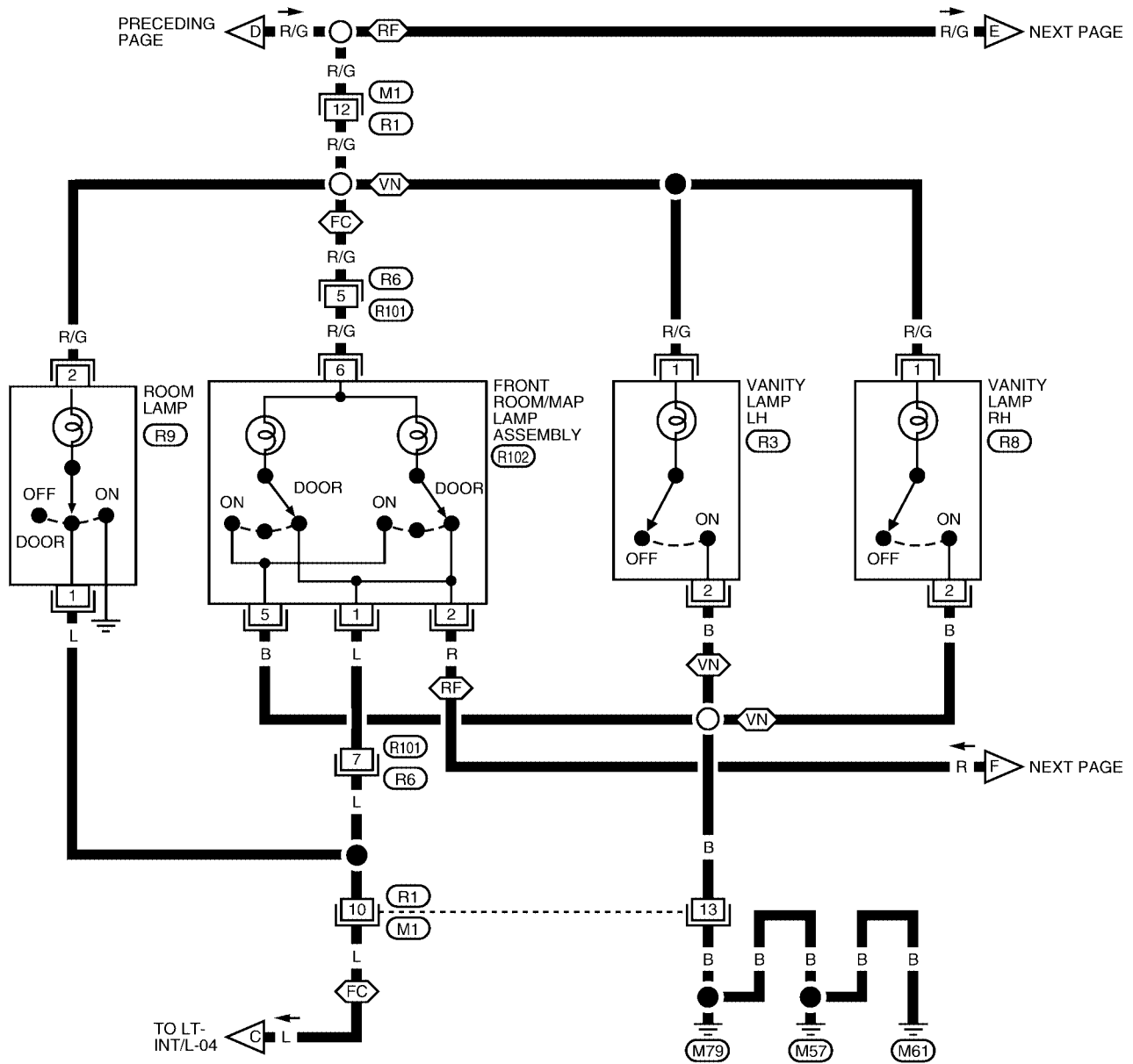

WKWA2451E

# INTERIOR ROOM LAMP

LT-INT/L-07

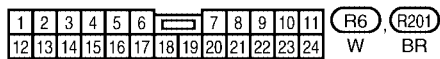
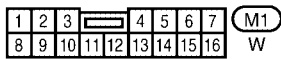
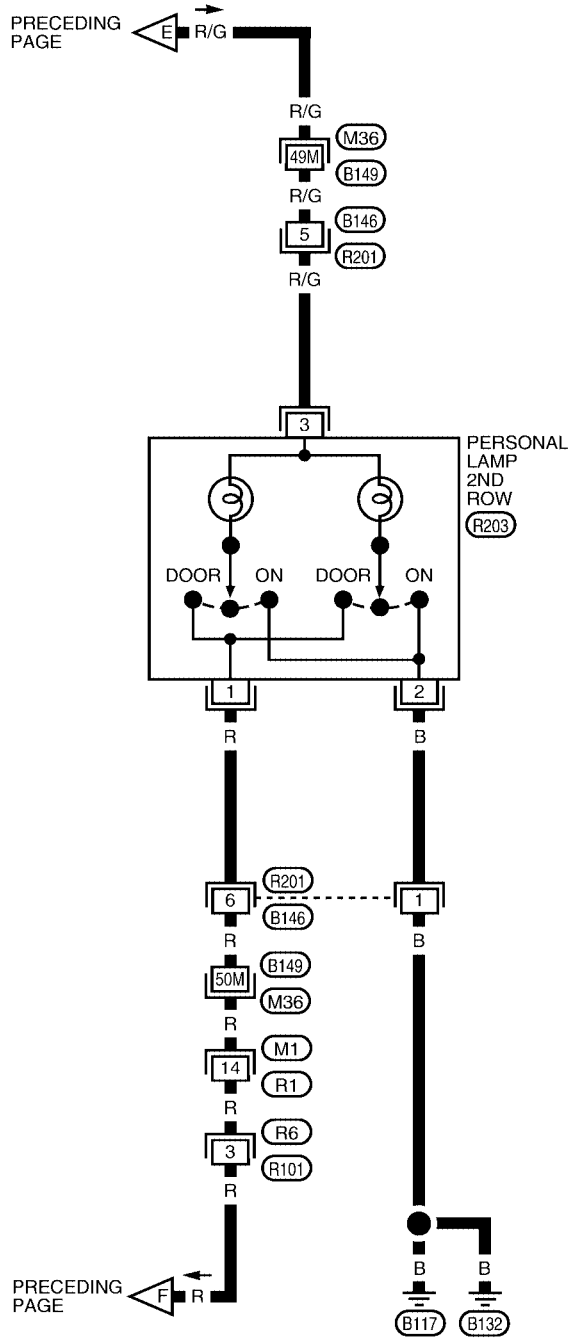

REFER TO THE FOLLOWING.  
 (M36) - SUPER MULTIPLE JUNCTION (SMJ)

WKWA2452E

# INTERIOR ROOM LAMP

LT-INT/L-08

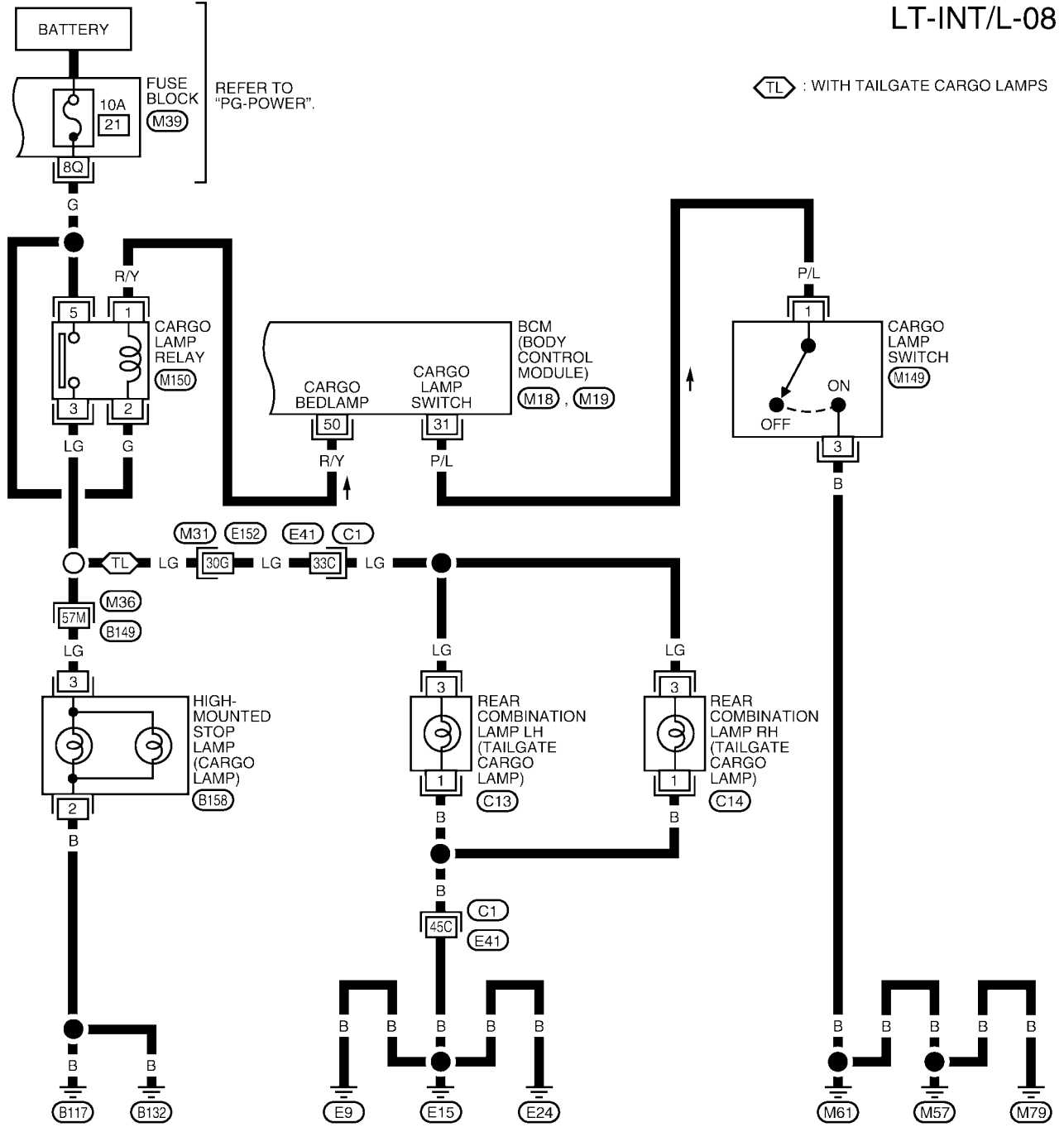

⬠ : WITH TAILGATE CARGO LAMPS

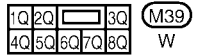

REFER TO THE FOLLOWING.  
M31, M36, C1 - SUPER MULTIPLE JUNCTION (SMJ)

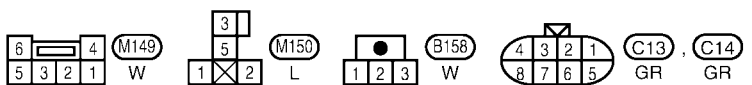
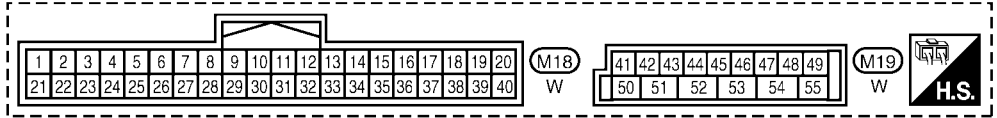

WKWA2471E

# INTERIOR ROOM LAMP

## Terminals and Reference Values for BCM

EKS00AC7

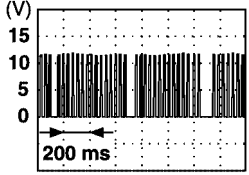
Terminal No.	Wire color	Signal name	Measuring condition			Reference value (Approx.)	
			Ignition switch	Operation or condition			
12 <sup>1</sup>	R/L	Front door switch RH signal	OFF	Front door switch RH	ON (open)	0V	
					OFF (closed)	Battery voltage	
12 <sup>2</sup>	R/L	Door switch RH signal	OFF	Door switch RH	ON (open)	0V	
					OFF (closed)	Battery voltage	
13 <sup>1</sup>	GR	Rear door switch RH signal	OFF	Rear door switch RH	ON (open)	0V	
					OFF (closed)	Battery voltage	
22	G	Power window switch serial link	—	—	 <p style="text-align: right; font-size: small;">PIA2344J</p>		
31	P/L	Cargo lamp switch signal	OFF	Cargo lamp switch ON.		0V	
				Cargo lamp switch OFF.		Battery voltage	
37	B/R	Key-in switch detection signal	OFF	Vehicle key is removed.		0V	
				Vehicle key is inserted.		Battery voltage	
38	W/L	Ignition power supply	ON	—	Battery voltage		
39	L	CAN-H	—	—	—		
40	P	CAN-L	—	—	—		
47 <sup>1</sup>	SB	Front door switch LH signal	OFF	Front door switch LH	ON (open)	0V	
					OFF (closed)	Battery voltage	
47 <sup>2</sup>	SB	Door switch LH signal	OFF	Door switch LH	ON (open)	0V	
					OFF (closed)	Battery voltage	
48 <sup>1</sup>	R/Y	Rear door switch LH signal	OFF	Rear door switch LH	ON (open)	0V	
					OFF (closed)	Battery voltage	
50	R/Y	Cargo bedlamp control	OFF	Cargo lamp switch ON		0V	
				Cargo lamp switch OFF		Battery voltage	
56	R/G	Battery saver output signal	OFF	30 minutes after ignition switch is turned to OFF		0V	
			ON	—	Battery voltage		
57	Y/R	Battery power supply	OFF	—	Battery voltage		
62	R/W	Step lamp signal	OFF	Any door is open (ON)		0V	
				All doors are closed (OFF)		Battery voltage	
63	L	Interior room/map lamp signal	OFF	Each interior lamp switch in DOOR position	Any door switch	ON (open)	0V
						OFF (closed)	Battery voltage
67	B	Ground	ON	—	0V		
70	W/B	Battery power supply	OFF	—	Battery voltage		

1 Crew cab  
2 King cab

# INTERIOR ROOM LAMP

EKS00AC8

## How to Proceed With Trouble Diagnosis

1. Confirm the symptom or customer complaint.
2. Understand operation description and function description. Refer to [LT-127, "System Description"](#).
3. Carry out the Preliminary Check. Refer to [LT-143, "Preliminary Check"](#).
4. Check symptom and repair or replace the cause of malfunction.
5. Does the interior room lamp operate normally? If YES: GO TO 6. If NO: GO TO 4.
6. Inspection End.

## Preliminary Check

EKS00AC9

### INSPECTION FOR POWER SUPPLY AND GROUND CIRCUIT

#### 1. CHECK FUSES OR FUSIBLE LINK

Check for blown BCM fuses or fusible link.

Unit	Power source	Fuse or fusible link No.
BCM	Battery	f
		22
	Ignition switch ON or START position	59

Refer to [LT-134, "Wiring Diagram — INT/L —"](#).

OK or NG

OK >> GO TO 2.

NG >> If fuse is blown, be sure to eliminate cause of malfunction before installing new fuse. Refer to [PG-4, "POWER SUPPLY ROUTING CIRCUIT"](#).

#### 2. CHECK POWER SUPPLY CIRCUIT

1. Disconnect BCM connectors.
2. Check voltage between BCM connector and ground.

Terminals		Ignition switch position	Ignition switch position	
(+)	(-)		OFF	ON
Connector	Terminal (Wire color)	Ground	OFF	ON
	M20		57 (Y/R)	Battery voltage
	70 (W/B)		Battery voltage	Battery voltage
M18	38 (W/L)		0V	Battery voltage

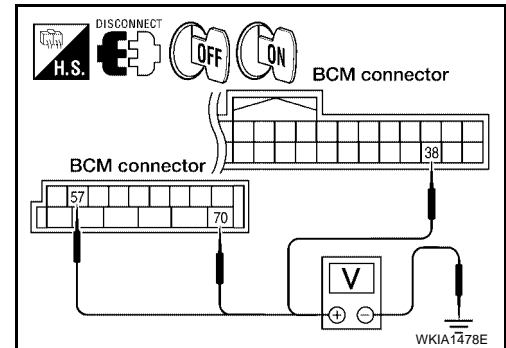

OK or NG

OK >> GO TO 3.

NG >> Check harness for open between BCM and fuse.

#### 3. CHECK GROUND CIRCUIT

Check continuity between BCM and ground.

Terminals		Continuity
Connector	Terminal (Wire color)	
M20	67 (B)	Ground Yes

OK or NG

OK >> Inspection End.

NG >> Check harness ground circuit.

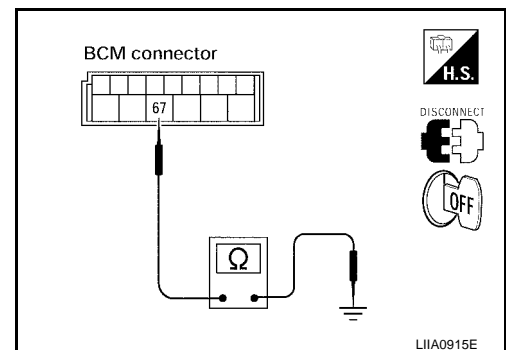

# INTERIOR ROOM LAMP

## CONSULT-II Function (BCM)

EKS00ACA

CONSULT-II can display each diagnostic item using the diagnostic test modes shown following.

BCM diagnostic test item	Diagnostic mode	Description
Inspection by part	WORK SUPPORT	Supports inspections and adjustments. Commands are transmitted to the BCM for setting the status suitable for required operation, input/output signals are received from the BCM and received data is displayed.
	DATA MONITOR	Displays BCM input/output data in real time.
	ACTIVE TEST	Operation of electrical loads can be checked by sending drive signal to them.
	SELF-DIAG RESULTS	Displays BCM self-diagnosis results.
	CAN DIAG SUPPORT MNTR	The result of transmit/receive diagnosis of CAN communication can be read.
	ECU PART NUMBER	BCM part number can be read.
	CONFIGURATION	Performs BCM configuration read/write functions.

## CONSULT-II OPERATION

### CAUTION:

If CONSULT-II is used with no connection of CONSULT-II CONVERTER, malfunctions might be detected in self-diagnosis depending on control unit which carries out CAN communication.

1. With the ignition switch OFF, connect CONSULT-II and CONSULT-II CONVERTER to the data link connector, then turn ignition switch ON.

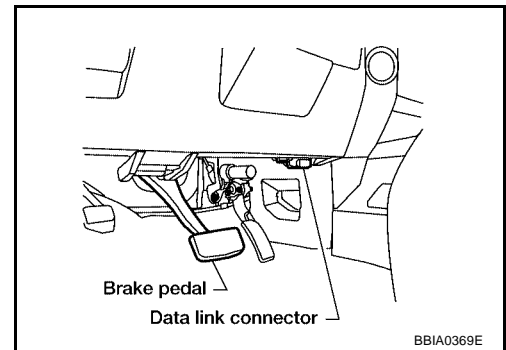

2. Touch "START (NISSAN BASED VHCL)".

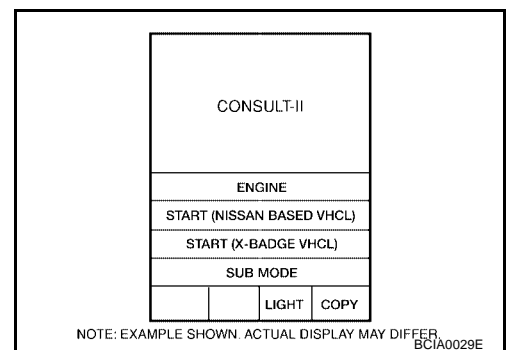

3. Touch "BCM" on "SELECT SYSTEM" screen.  
If "BCM" is not indicated, go to [GI-38, "CONSULT-II Data Link Connector \(DLC\) Circuit"](#).

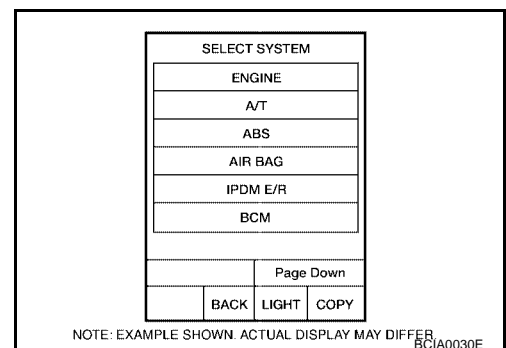



# INTERIOR ROOM LAMP

4. Touch "INT LAMP" on "SELECT SYSTEM" screen.

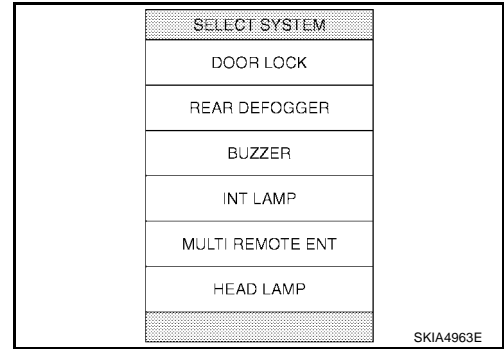

## WORK SUPPORT

### Operation Procedure

1. Touch "INT LAMP" on "SELECT SYSTEM" screen.
2. Touch "WORK SUPPORT" on "SELECT DIAG MODE" screen.
3. Touch "SET I/L D-UNLCK INTCON" on "SELECT WORK ITEM" screen.
4. Touch "START".
5. Touch "CHANGE SETT".
6. The setting will be changed and "CUSTOMIZING COMPLETED" will be displayed.
7. Touch "END".

### Display Item List

Item	Description	CONSULT-II
SET I/L D-UNLCK INTCON	The 30 seconds operating function of the interior room lamps can be selected when driver door is released (unlocked).	ON/OFF
ROOM LAMP ON TIME SET	The time in order to escalate illumination can be adjusted when the interior room lamps are turned on.	MODE 1 - 7
ROOM LAMP OFF TIME SET	The time in order to diminish illumination can be adjusted when the interior room lamps are turned off.	MODE 1 - 7

Reference between "MODE" and "TIME" for "TURN ON/OFF".

MODE	1	2	3	4	5	6	7
Time (sec.)	0.5	1	2	3	4	5	0

## DATA MONITOR

### Operation Procedure

1. Touch "INT LAMP" on "SELECT TEST ITEM" screen.
2. Touch "DATA MONITOR" on "SELECT DIAG MODE" screen.
3. Touch either "ALL SIGNALS" or "SELECTION FROM MENU" on "SELECT MONITOR ITEM" screen.

All signals	Monitors all the signals.
Selection from menu	Selects and monitors the individual signal.

4. Touch "START".
5. When "SELECTION FROM MENU" is selected, touch items to be monitored. When "ALL SIGNALS" is selected, all the items will be monitored.
6. Touch "RECORD" while monitoring, then the status of the monitored item can be recorded. To stop recording, touch "STOP".

### Display Item List

Monitor item	Contents
IGN ON SW "ON/OFF"	Displays "IGN position (ON)/OFF, ACC position (OFF)" judged from the ignition switch signal.
KEY ON SW "ON/OFF"	Displays "Key inserted (ON)/key removed (OFF)" status judged from the key switch signal.

# INTERIOR ROOM LAMP

Monitor item	Contents
DOOR SW-DR "ON/OFF"	Displays status of the driver door as judged from the driver door switch signal. (Door is open: ON/Door is closed: OFF)
DOOR SW-AS "ON/OFF"	Displays "Door open (ON)/Door closed (OFF)" status, determined from passenger door switch signal.
DOOR SW-RR "ON/OFF"	Displays "Door open (ON)/Door closed (OFF)" status, determined from rear door switch RH signal.
DOOR SW-RL "ON/OFF"	Displays "Door open (ON)/Door closed (OFF)" status, determined from rear door switch LH signal.
BACK DOOR SW "ON/OFF"	Not used.
KEY CYL LK-SW "ON/OFF"	Displays "Door locked (ON)" status, determined from key cylinder lock switch in driver door.
KEY CYL UN-SW "ON/OFF"	Displays "Door unlocked (OFF)" status, determined from key cylinder lock switch in driver door.
CDL LOCK SW "ON/OFF"	Displays "Door locked (ON)/Door unlocked (OFF)" status, determined from locking detection switch in driver door.
CDL UNLOCK SW "ON/OFF"	Displays "Door unlocked (OFF)" status, determined from locking detection switch in passenger door.
KEYLESS LOCK "ON/OFF"	Displays "Locked (ON)/Other (OFF)" status, determined from lock signal.
KEYLESS UNLOCK "ON/OFF"	Displays "Unlocked (ON)/Other (OFF)" status, determined from unlock signal.

## ACTIVE TEST

### Operation Procedure

1. Touch "INT LAMP" on "SELECT TEST ITEM" screen.
2. Touch "ACTIVE TEST" on "SELECT DIAG MODE" screen.
3. Touch item to be tested and check operation of the selected item.
4. During the operation check, touching "BACK" or "OFF" deactivates the operation.

### Display Item List

Test item	Description
INT LAMP	Interior room lamp can be operated by any ON-OFF operations.
IGN ILLUM <sup>NOTE</sup>	Ignition keyhole illumination can be operated by ON-OFF operation.

NOTE: This item is displayed but this model is not equipped.

## Front Room/Map Lamp Assembly Control Does Not Operate

EKS00ACB

### 1. CHECK EACH SWITCH

Select "BCM" on CONSULT-II. With "INT LAMP" data monitor, make sure switches listed in display item list turn ON-OFF linked with switch operation. Refer to [LT-145, "Display Item List"](#) for switches and their functions.

#### OK or NG

- OK >> GO TO 2.  
 NG >> Inspect malfunctioning switch system.

DATA MONITOR	
MONITOR	
IGN ON SW	ON
KEY ON SW	ON
DOOR SW-DR	ON
DOOR SW-AS	ON
DOOR SW-RR	OFF
DOOR SW-RL	OFF
BACK DOOR SW	OFF
KEY CYL LK-SW	OFF
KEY CYL UN-SW	OFF

SKIA5930E

# INTERIOR ROOM LAMP

## 2. ACTIVE TEST

1. Select "BCM" on CONSULT-II. Select "INT LAMP" active test.
2. When switch is in "DOOR" position, use active test to make sure interior room lamp operates.

**Room lamps should turn on.**

OK or NG

- OK >> Replace BCM. Refer to [BCS-19, "Removal and Installation of BCM"](#) .
- NG >> GO TO 3.

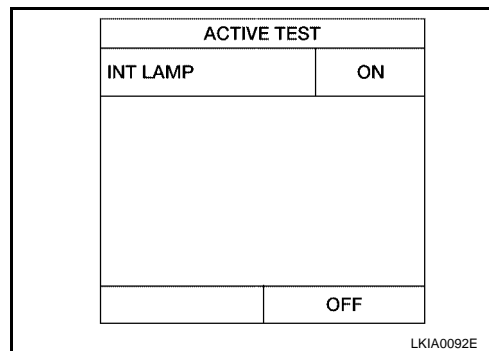

## 3. CHECK FRONT ROOM/MAP LAMP ASSEMBLY INPUT

1. Turn ignition switch OFF.
2. Check voltage between front room/map lamp assembly harness connector R102 terminal 6 (R/G) and ground.

**6 (R/G) - Ground : Battery voltage should exist.**

OK or NG

- OK >> GO TO 4.
- NG >> GO TO 5.

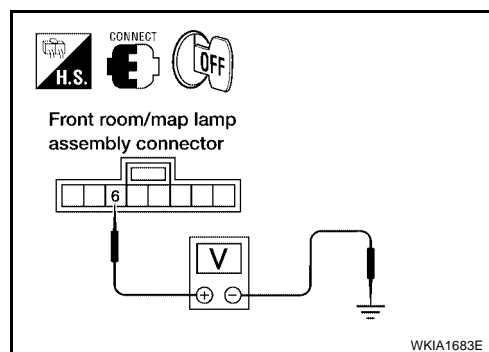

## 4. CHECK FRONT ROOM/MAP LAMP ASSEMBLY CIRCUIT

1. Disconnect BCM connector.
2. Check continuity between BCM harness connector M20 terminal 63 (L) and front room/map lamp assembly harness connector R102 terminal 1 (L).

**63 (L) - 1 (L) : Continuity should exist.**

OK or NG

- OK >> Replace front room/map lamp assembly.
- NG >> Repair harness or connector.

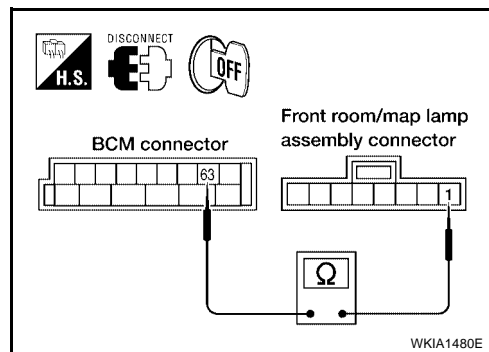

## 5. CHECK FRONT ROOM/MAP LAMP ASSEMBLY CIRCUIT

1. Disconnect BCM connector and interior room lamp connector.
2. Check continuity between BCM harness connector M20 terminal 56 (R/G) and front room/map lamp assembly harness connector R102 terminal 6 (R/G).

**56 (R/G) - 6 (R/G) : Continuity should exist.**

OK or NG

- OK >> Replace BCM if interior lamp does not work after setting the connector again. Refer to [BCS-19, "Removal and Installation of BCM"](#) .
- NG >> Repair harness or connector between BCM and room/map lamp.

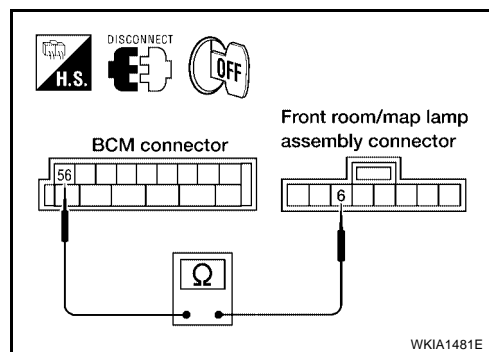

# INTERIOR ROOM LAMP

## Personal Lamp 2nd Row Control Does Not Operate (Room/Map Lamps Operate)

EKS00ACC

### 1. CHECK EACH DOOR SWITCH

Select "BCM" on CONSULT-II. With "INT LAMP" data monitor, make sure switches listed in display item list turn ON-OFF linked with switch operation. Refer to [LT-128, "SWITCH OPERATION"](#) for switches and their function.

OK or NG

- OK >> GO TO 2.
- NG >> Inspect malfunctioning door switch.

DATA MONITOR	
MONITOR	
IGN ON SW	ON
KEY ON SW	ON
DOOR SW-DR	ON
DOOR SW-AS	ON
DOOR SW-RR	OFF
DOOR SW-RL	OFF
BACK DOOR SW	OFF
KEY CYL LK-SW	OFF
KEY CYL UN-SW	OFF

SKIA5930E

### 2. CHECK PERSONAL LAMP 2ND ROW OUTPUT

1. Turn ignition switch OFF.
2. Confirm lamp switch is in the "DOOR" position.
3. Disconnect personal lamp 2nd row connector.
4. Open any door.
5. Check voltage between personal lamp 2nd row harness connector R203 terminal 3 (R/G) and ground.

**3 (R/G) - Ground : Battery voltage should exist.**

OK or NG

- OK >> GO TO 3.
- NG >> Repair harness or connector.

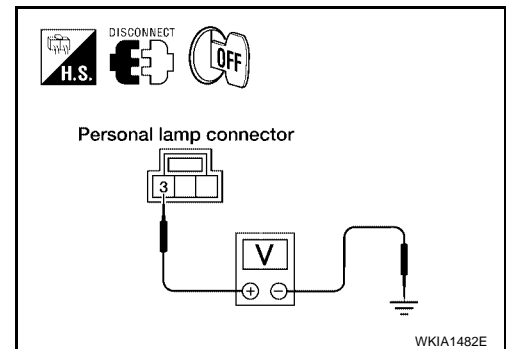

### 3. CHECK PERSONAL LAMP 2ND ROW CONTROL CIRCUIT

1. Disconnect front room/map lamp assembly connector.
2. Check continuity between front room/map lamp assembly harness connector R102 terminal 2 (R) and personal lamp 2nd row harness connector R203 terminal 1 (R).

**2 (R) - 1 (R) : Continuity should exist.**

OK or NG

- OK >> Replace personal lamp 2nd row.
- NG >> Repair harness or connector.

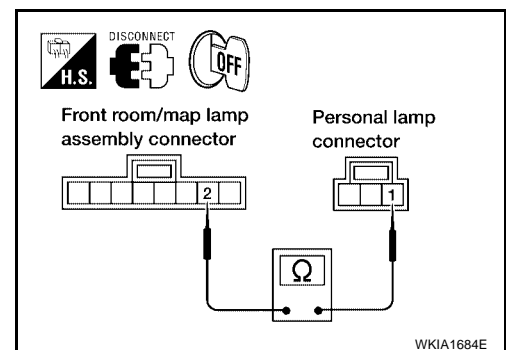

# INTERIOR ROOM LAMP

EKS00ACD

## All Step/Foot/Puddle Lamps Do Not Operate

### 1. CHECK EACH DOOR SWITCH

Select "BCM" on CONSULT-II. With "INT LAMP" data monitor, make sure switches listed in display item list turn ON-OFF linked with switch operation. Refer to [LT-145, "Display Item List"](#) for switches and their functions.

OK or NG

- OK >> GO TO 2.
- NG >> Inspect malfunctioning switch system.

DATA MONITOR	
MONITOR	
IGN ON SW	ON
KEY ON SW	ON
DOOR SW-DR	ON
DOOR SW-AS	ON
DOOR SW-RR	OFF
DOOR SW-RL	OFF
BACK DOOR SW	OFF
KEY CYL LK-SW	OFF
KEY CYL UN-SW	OFF

SKIA5930E

### 2. CHECK STEP LAMP POWER SUPPLY

1. Turn ignition switch OFF.
2. Check voltage between front step lamp LH harness connector D11 terminal + (R/G) and ground.

**+ (R/G) - Ground : Battery voltage should exist.**

OK or NG

- OK >> GO TO 3.
- NG >> GO TO 4.

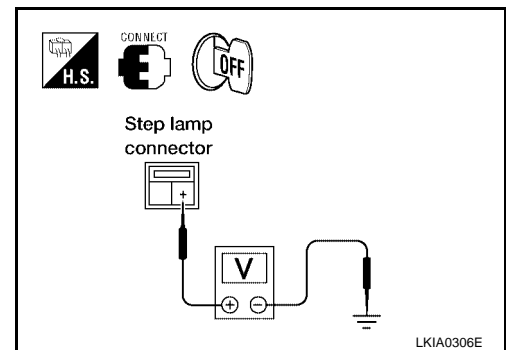

### 3. CHECK STEP LAMP CONTROL CIRCUIT

1. Disconnect BCM connector and front step lamp LH connector.
2. Check continuity between BCM harness connector M20 terminal 62 (R/W) and front step lamp LH harness connector D11 terminal - (R/W).

**- (R/W) - 62 (R/W) : Continuity should exist.**

OK or NG

- OK >> Replace BCM if step lamp does not work after setting the connector again. Refer to [BCS-19, "Removal and Installation of BCM"](#).
- NG >> Repair harness or connector.

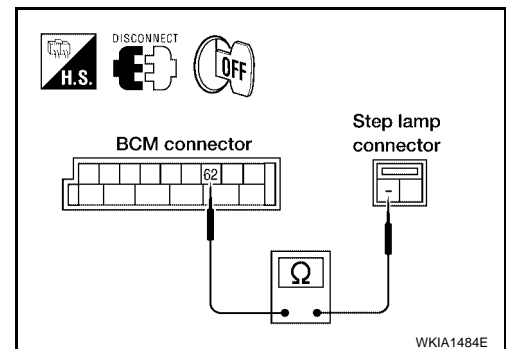

### 4. CHECK STEP LAMP CIRCUIT

1. Disconnect BCM connector and front step lamp LH connector.
2. Check continuity between BCM harness connector M20 terminal 56 (R/G) and front step lamp LH harness connector D11 terminal + (R/G).

**+ (R/G) - 56 (R/G) : Continuity should exist.**

OK or NG

- OK >> Replace BCM if step lamp does not work after setting the connector again. Refer to [BCS-19, "Removal and Installation of BCM"](#).
- NG >> Repair harness or connector.

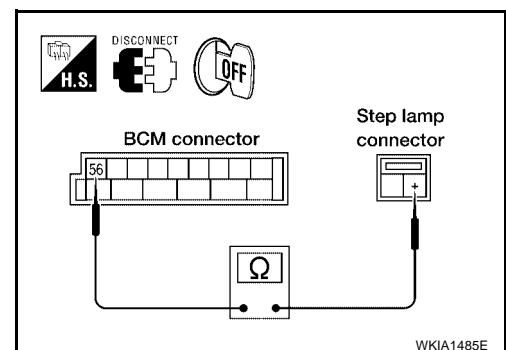

# INTERIOR ROOM LAMP

## All Interior Room Lamps Do Not Operate

EKS00ACE

### 1. CHECK POWER SUPPLY CIRCUIT

1. All interior room lamp switches are OFF.
2. Turn ignition switch ON.
3. Check voltage between BCM harness connector M20 terminal 56 (R/G) and ground.

**56 (R/G) - Ground : Battery voltage should exist.**

#### OK or NG

- OK >> Repair harness or connector. In a case of making a short circuit, be sure to disconnect battery negative cable after repairing harness, and then reconnect.
- NG >> Replace BCM. Refer to [BCS-19. "Removal and Installation of BCM"](#).

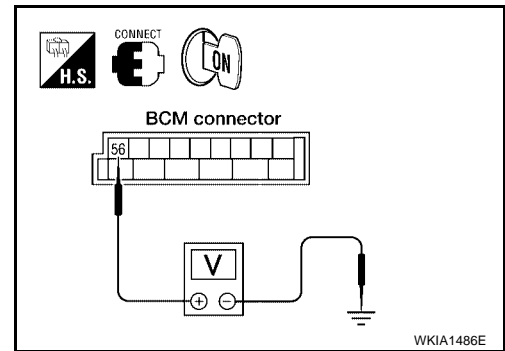

# ILLUMINATION

PFP:27545

## ILLUMINATION

### Component Parts and Harness Connector Location

EKS00ACF

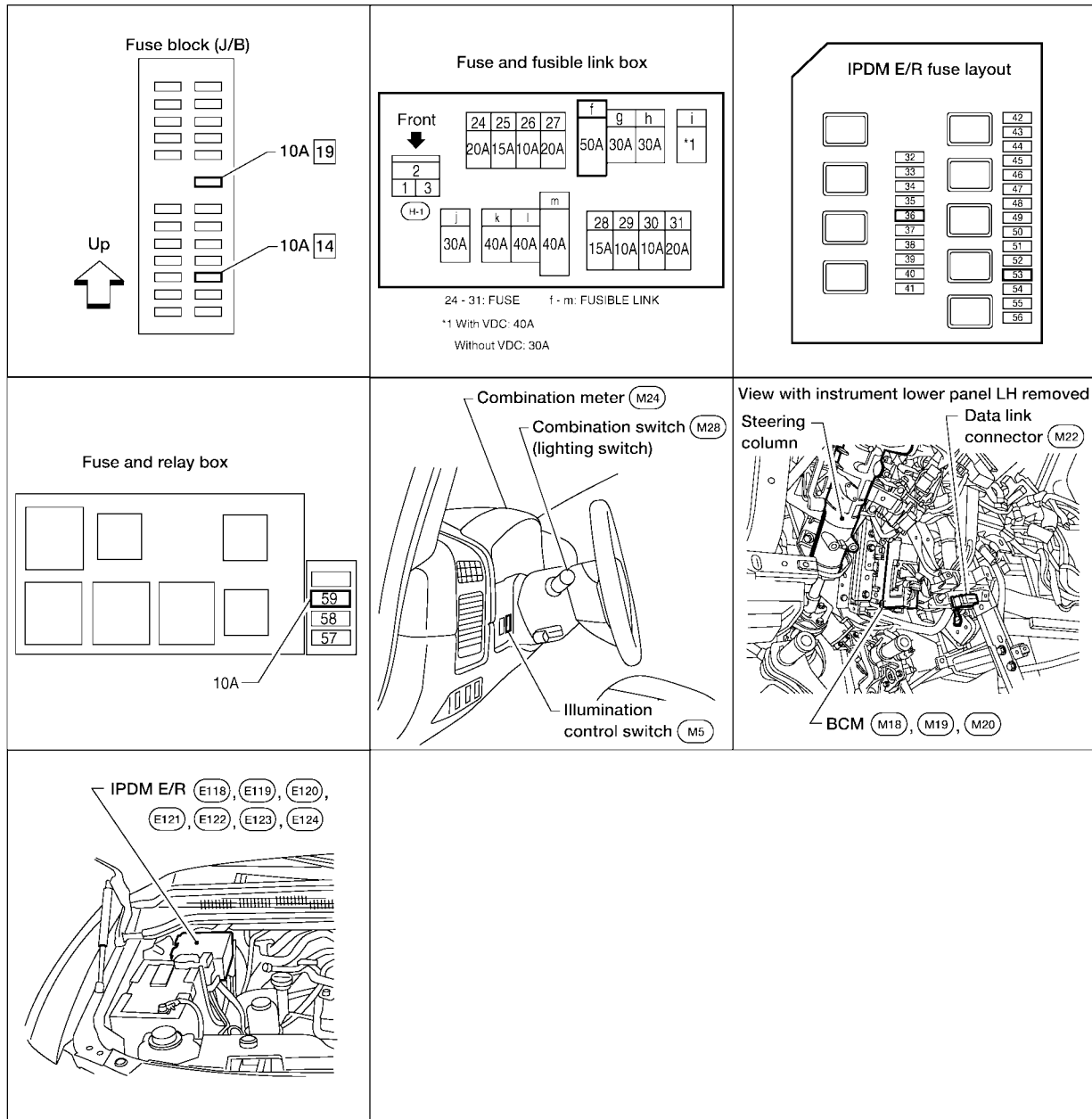

A  
B  
C  
D  
E  
F  
G  
H  
I  
J  
LT  
L  
M

WKIA3587E

## System Description

EKS00ACG

Control of the illumination lamps operation is dependent upon the position of the lighting switch (combination switch). When the lighting switch is placed in the 1ST or 2ND position (or if the auto light system is activated) the BCM (body control module) receives input signal requesting the illumination lamps to illuminate. This input signal is communicated to the IPDM E/R (intelligent power distribution module engine room) across the CAN communication lines. The CPU (central processing unit) of the IPDM E/R controls the tail lamp relay coil. This relay, when energized, directs power to the illumination lamps, which then illuminate.

Power is supplied at all times

- to tail lamp relay, located in the IPDM E/R, and
- through 50A fusible link (letter f, located in the fuse and fusible link box)
- to BCM terminal 70, and

# ILLUMINATION

---

- through 20A fuse (No. 53, located in the IPDM E/R)
- to CPU in the IPDM E/R, and
- through 10A fuse [No.19, located in fuse block (J/B)]
- to combination meter terminal 8, and
- to ignition relay, located in the IPDM E/R.

With the ignition switch in the ON or START position, power is supplied

- through 10A fuse (No. 59, located in the fuse and relay box)
- to BCM terminal 38, and
- to ignition relay, located in the IPDM E/R, and
- through 10A fuse [No. 14, located in the fuse block (J/B)]
- to combination meter terminal 24.

Ground is supplied

- to BCM terminal 67 and
- to combination meter terminal 17
- through grounds M57, M61, and M79, and
- to IPDM E/R terminals 38 and 59
- through grounds E9, E15 and E24.

## ILLUMINATION OPERATION BY LIGHTING SWITCH

With the lighting switch in the 1ST or 2ND position (or if the auto light system is activated), the BCM receives input signal requesting the illumination lamps to illuminate. This input signal is communicated to the IPDM E/R across the CAN communication lines. The CPU of the IPDM E/R controls the tail lamp relay coil, which, when energized, directs power

- through 10A fuse (No. 36, located in the IPDM E/R)
- through IPDM E/R terminal 49
- to illumination control switch terminal 1
- to VDC OFF switch terminal 3 (with VDC)
- to front room/map lamp assembly (console box illumination) terminal 7
- to AV switch terminal 3
- to hazard switch terminal 7
- to audio unit terminal 8
- to differential lock mode switch terminal 4 (with electronic locking rear differential)
- to rear sonar system OFF switch terminal 3 (with rear sonar system)
- to glove box lamp terminal + (with glove box lamp)
- to display control unit terminal 14 (with NAVI)
- to 4WD shift switch terminal 7 (with 4-wheel drive)
- to A/C control unit terminal 23
- to cargo lamp switch terminal 4
- to DVD player terminal 12 (with DVD entertainment system)
- to NAVI control unit terminal 25 (with NAVI)
- to pedal adjusting switch terminal 5
- to electric brake (pre-wiring) terminal 4
- to A/T device terminal 11 (with floor shift)
- to heated seat switch LH and RH terminal 5 (with heated seats)
- to tow mode switch terminal 3.

Illumination is controlled

- through illumination control switch terminal 2
- to VDC OFF switch terminal 4 (with VDC)
- to front room/map lamp assembly (console box illumination) terminal 8
- to AV switch terminal 4



# ILLUMINATION

- to hazard switch terminal 8
- to audio unit terminal 7
- to differential lock mode switch terminal 5 (with electronic locking rear differential)
- to rear sonar system OFF switch terminal 4 (with rear sonar system)
- to 4WD switch terminal 8 (with 4-wheel drive)
- to A/C control unit terminal 24
- to cargo lamp switch terminal 2
- to DVD player terminal 10 (with DVD entertainment system)
- to pedal adjusting switch terminal 6
- to A/T device terminal 12 (with floor shift)
- to heated seat switch LH and RH terminal 6 (with heated seats)
- to tow mode switch terminal 4
- to combination meter terminal 18.

Ground is supplied

- to illumination control switch terminal 3
- to glove box lamp terminal – (with glove box lamp)
- to display control unit terminal 3 (with NAVI) and
- to electric brake (pre-wiring) terminal 1
- through grounds M57, M61 and M79, and
- to NAVI control unit terminal 30 (with NAVI)
- through grounds B117 and B132.

With power and ground supplied, illumination lamps illuminate.

## EXTERIOR LAMP BATTERY SAVER CONTROL

When the combination switch (lighting switch) is in the 1ST or 2ND position (or if auto light system is activated), and the ignition switch is turned from ON or ACC to OFF, the battery saver control function is activated. Under this condition, the illumination lamps remain illuminated for 5 minutes, then the illumination lamps are turned off.

When the lighting switch is turned from OFF to 1ST or 2ND position (or if auto light system is activated) after illumination lamps are turned off by the battery saver control, the illumination lamps illuminate again.

Exterior lamp battery saver control mode can be changed by the function setting of CONSULT-II.

## CAN Communication System Description

Refer to [LAN-7, "CAN COMMUNICATION"](#).

A

B

C

D

E

F

G

H

I

J

LT

EKS00ACH

L

M

# ILLUMINATION

## Schematic

EKS00ACI

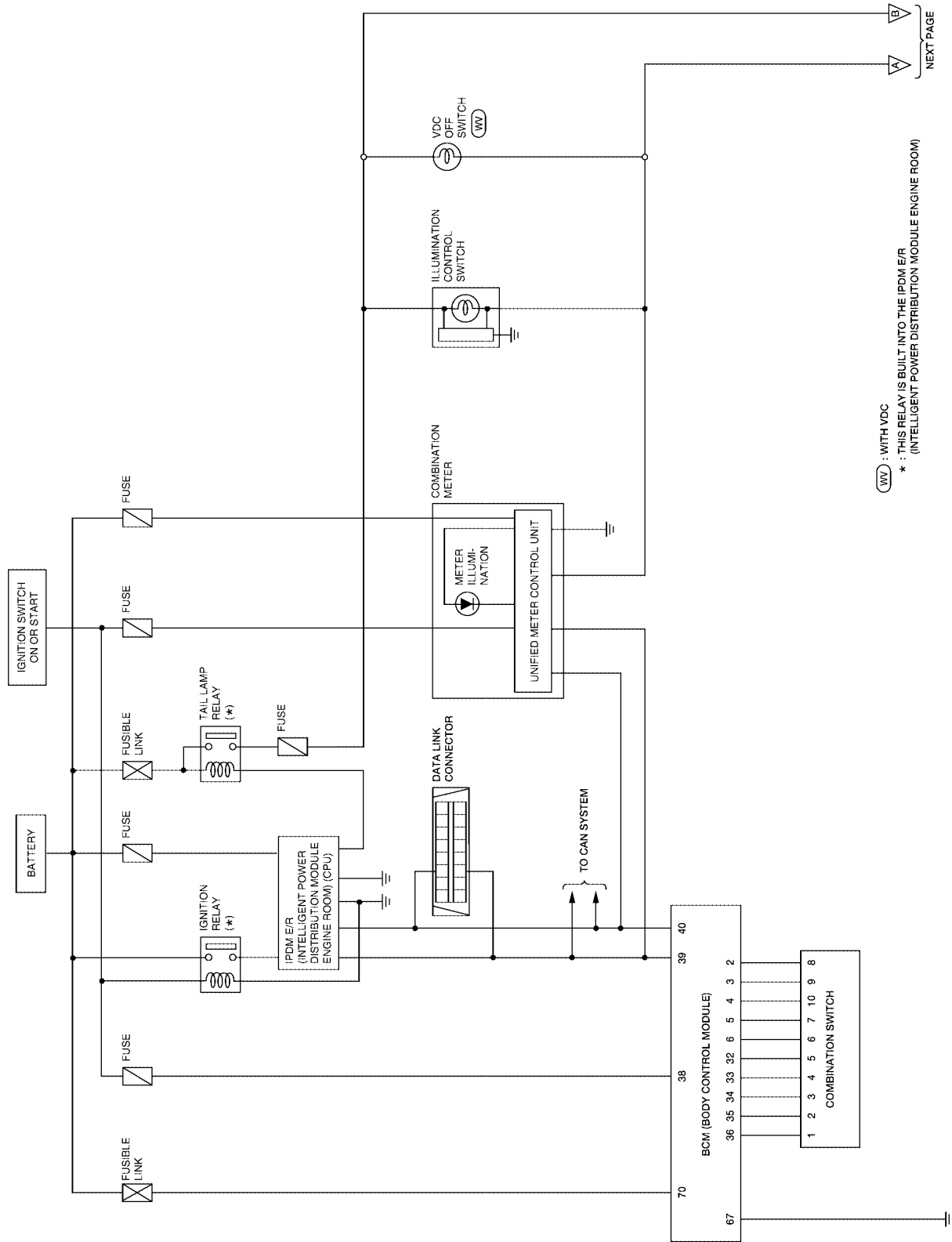

WKWA2453E

# ILLUMINATION

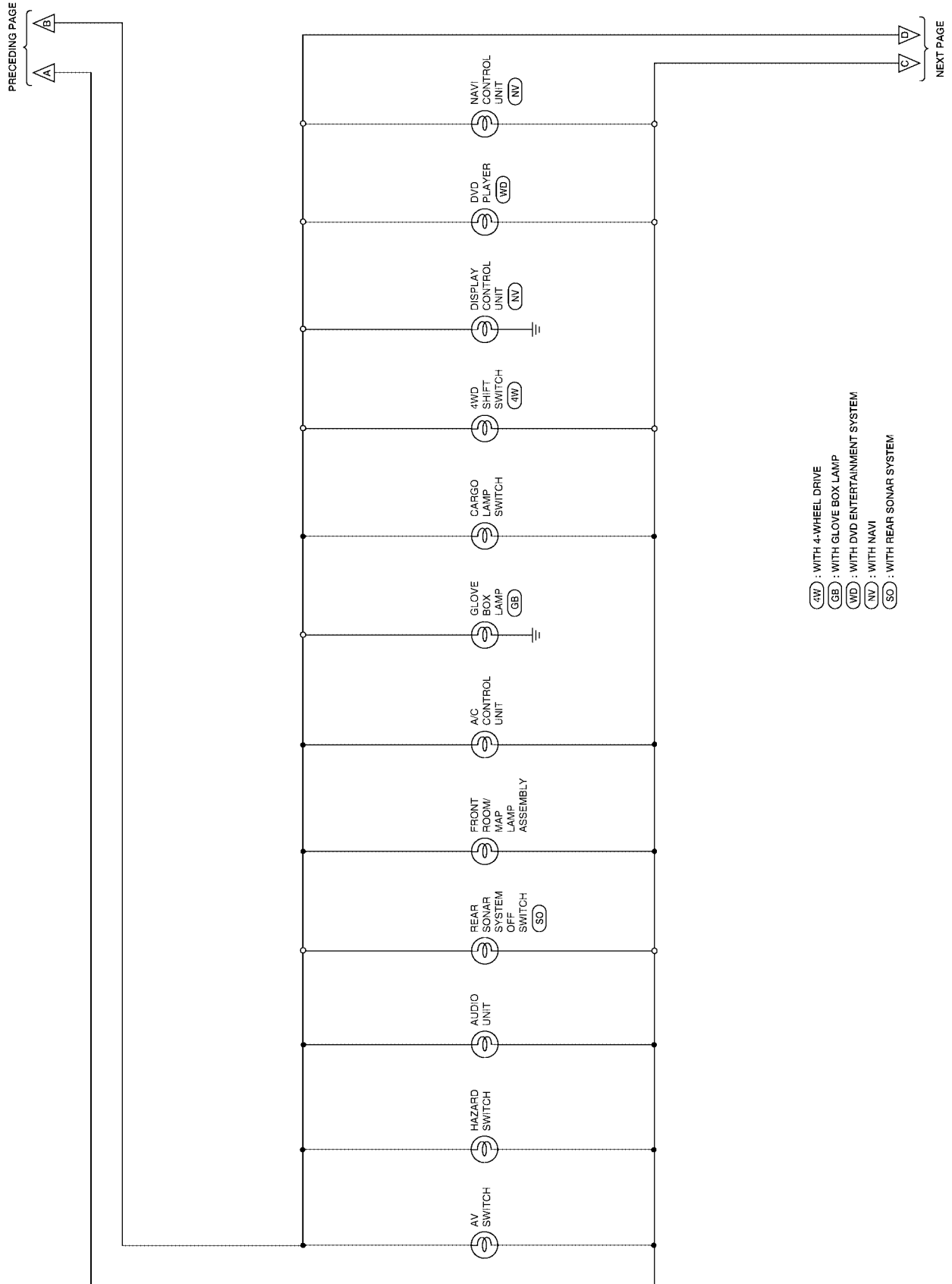

A  
B  
C  
D  
E  
F  
G  
H  
I  
J  
LT  
L  
M

# ILLUMINATION

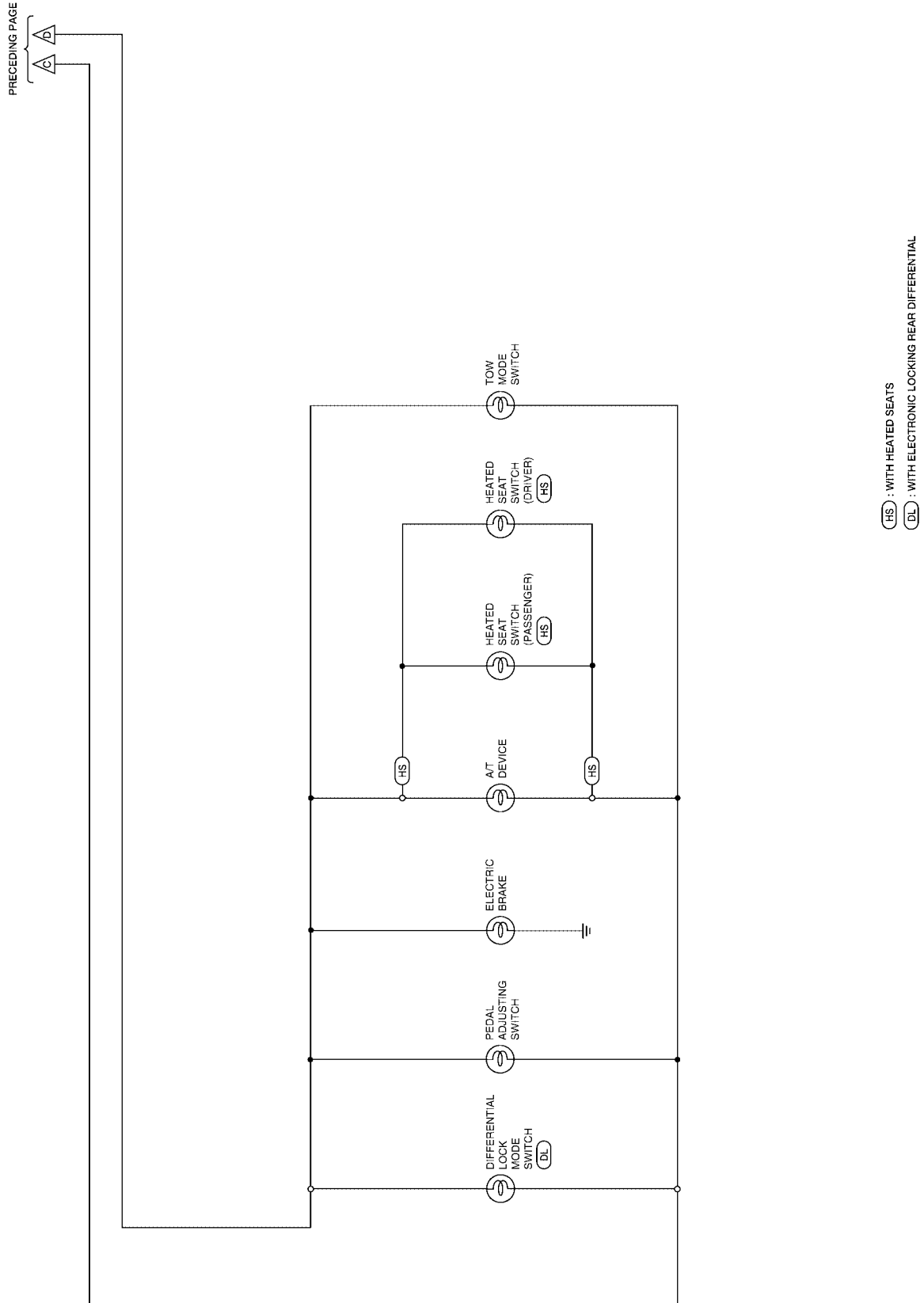

WKWA2473E

# ILLUMINATION

## Wiring Diagram — ILL —

EKS00ACJ

### LT-ILL-01

— : DATA LINE

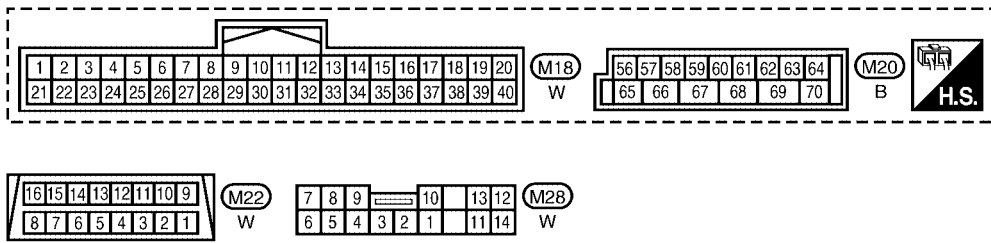
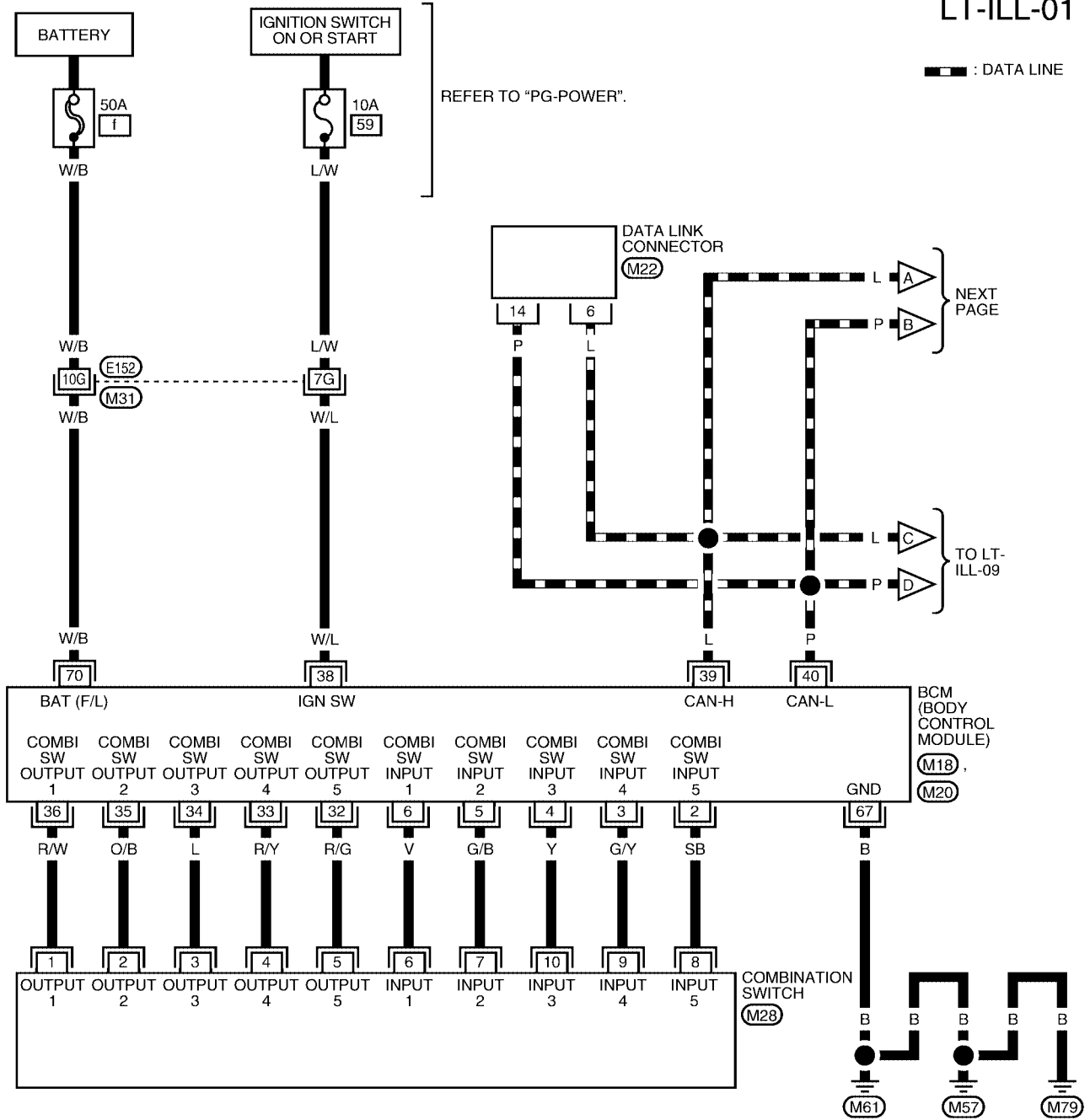

WKWA2427E

# ILLUMINATION

LT-ILL-02

▬ : DATA LINE

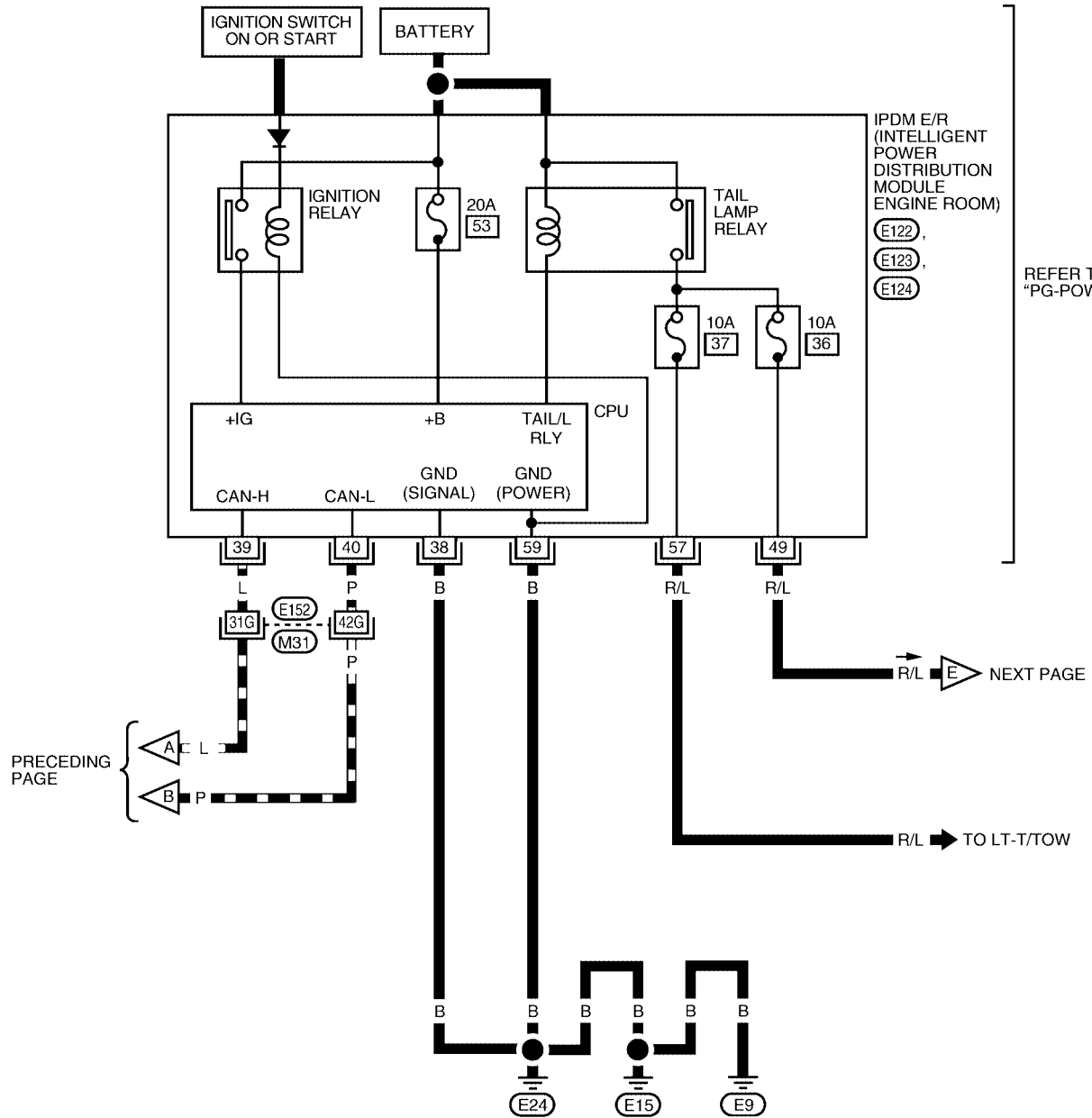

REFER TO "PG-POWER".

▶ NEXT PAGE

REFER TO THE FOLLOWING.  
**(M31)** - SUPER MULTIPLE JUNCTION (SMJ)

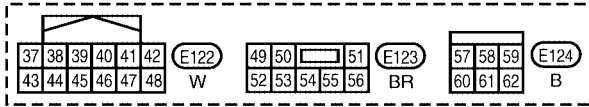

WKWA2454E

# ILLUMINATION

LT-ILL-03

PRECEDING PAGE

WV : WITH VDC

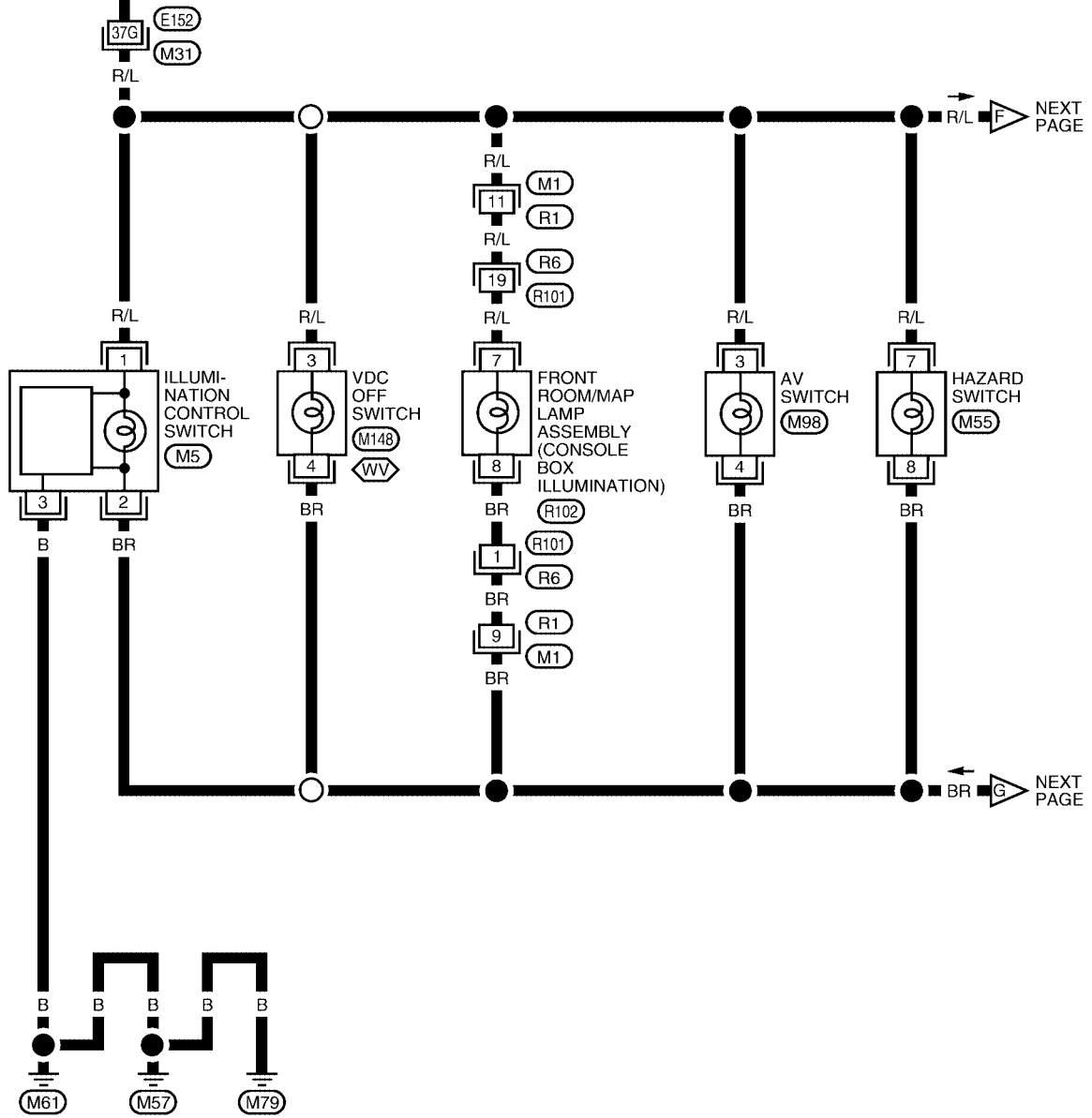

A  
B  
C  
D  
E  
F  
G  
H  
I  
J  
LT  
L  
M

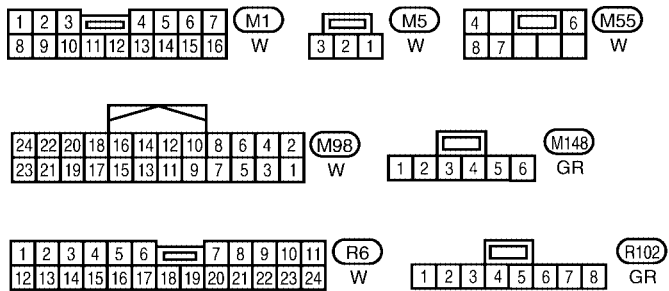



REFER TO THE FOLLOWING.  
 (M31) - SUPER MULTIPLE JUNCTION (SMJ)

WKWA2455E

# ILLUMINATION

LT-ILL-04

-  : WITH ELECTRONIC LOCKING REAR DIFFERENTIAL
-  : WITH GLOVE BOX LAMP
-  : WITH REAR SONAR SYSTEM

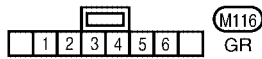
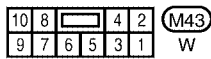
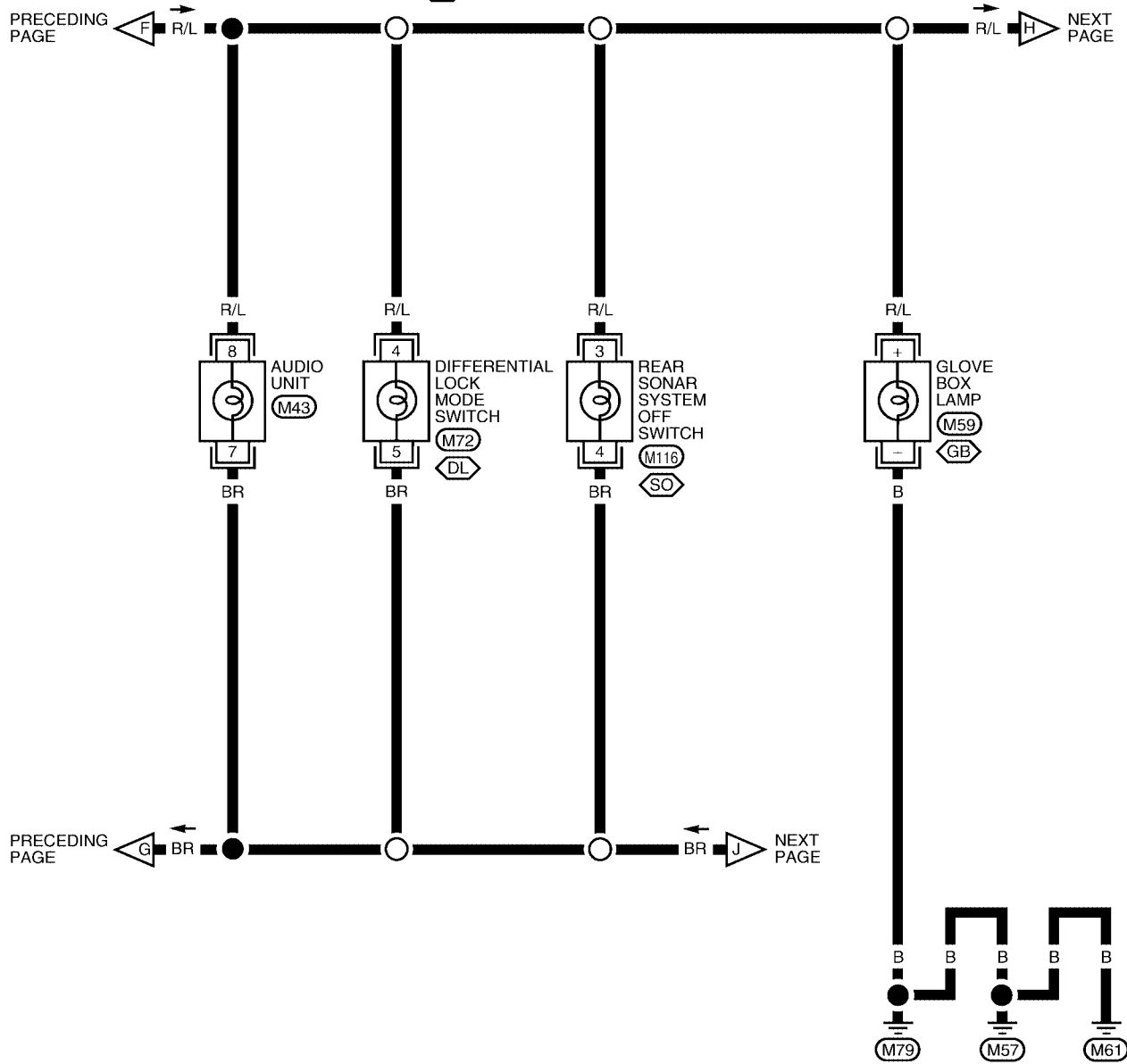



WKWA2456E



# ILLUMINATION

LT-ILL-05

 : WITH NAVI  
 : WITH 4-WHEEL DRIVE

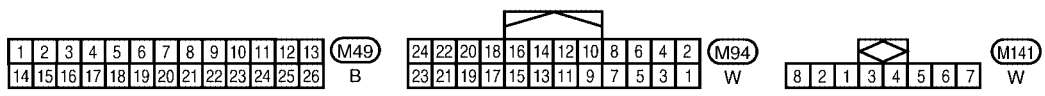
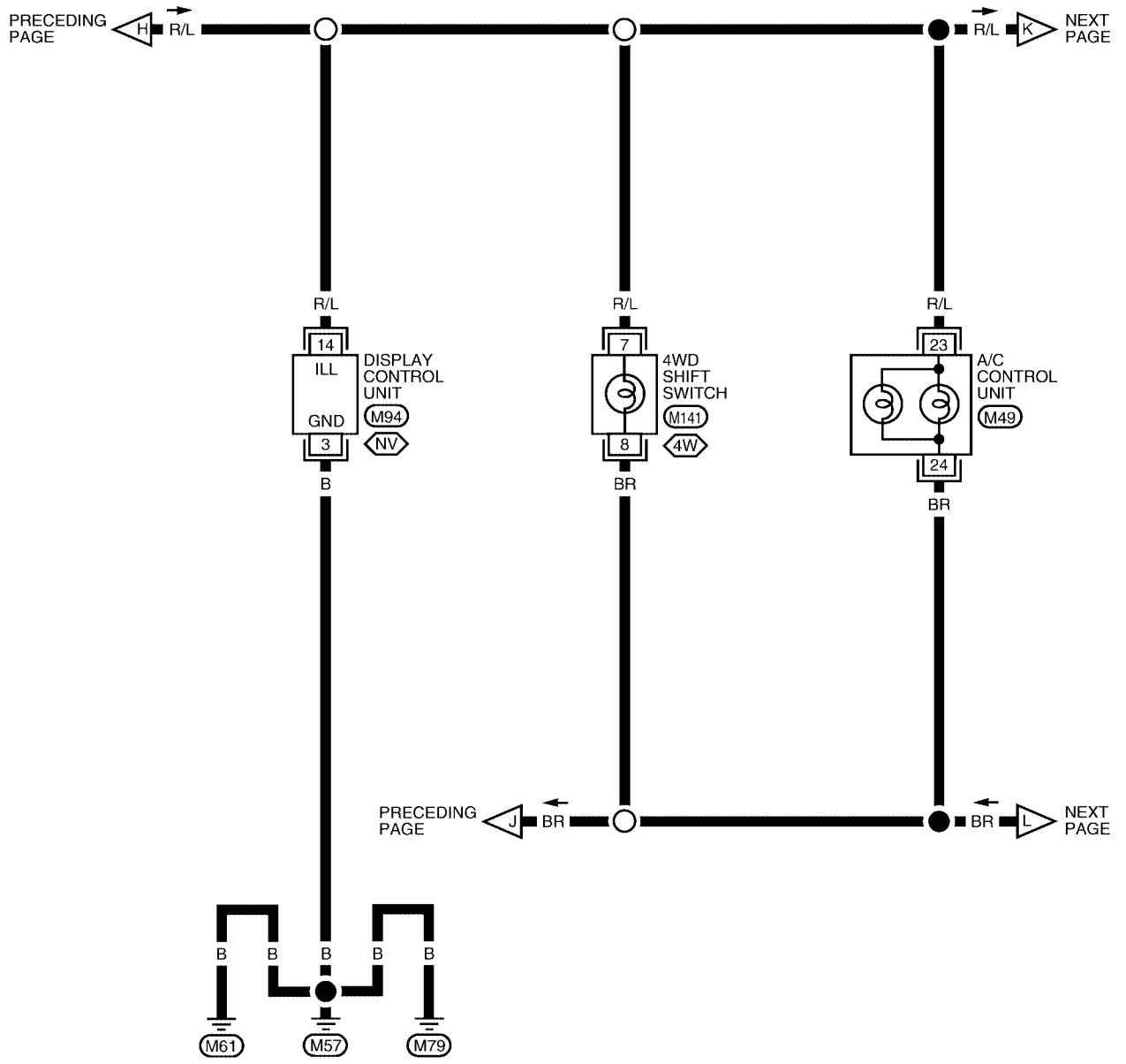

A  
B  
C  
D  
E  
F  
G  
H  
I  
J  
LT  
L  
M

WKWA2457E

# ILLUMINATION

LT-ILL-06

 : WITH NAVI

 : WITH DVD ENTERTAINMENT SYSTEM

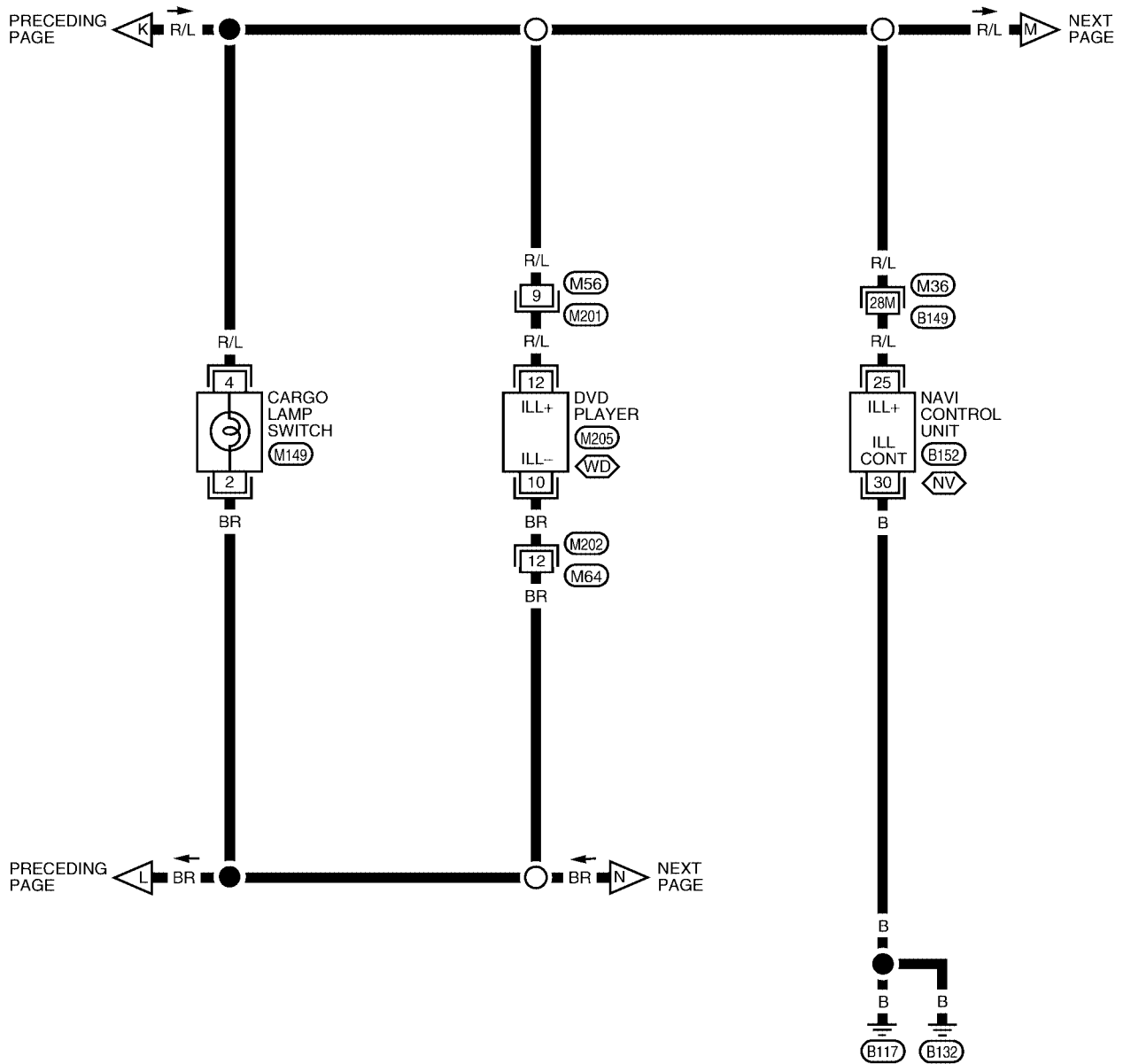

REFER TO THE FOLLOWING.  
 - SUPER MULTIPLE JUNCTION (SMJ)

WKWA2458E

# ILLUMINATION

LT-ILL-07

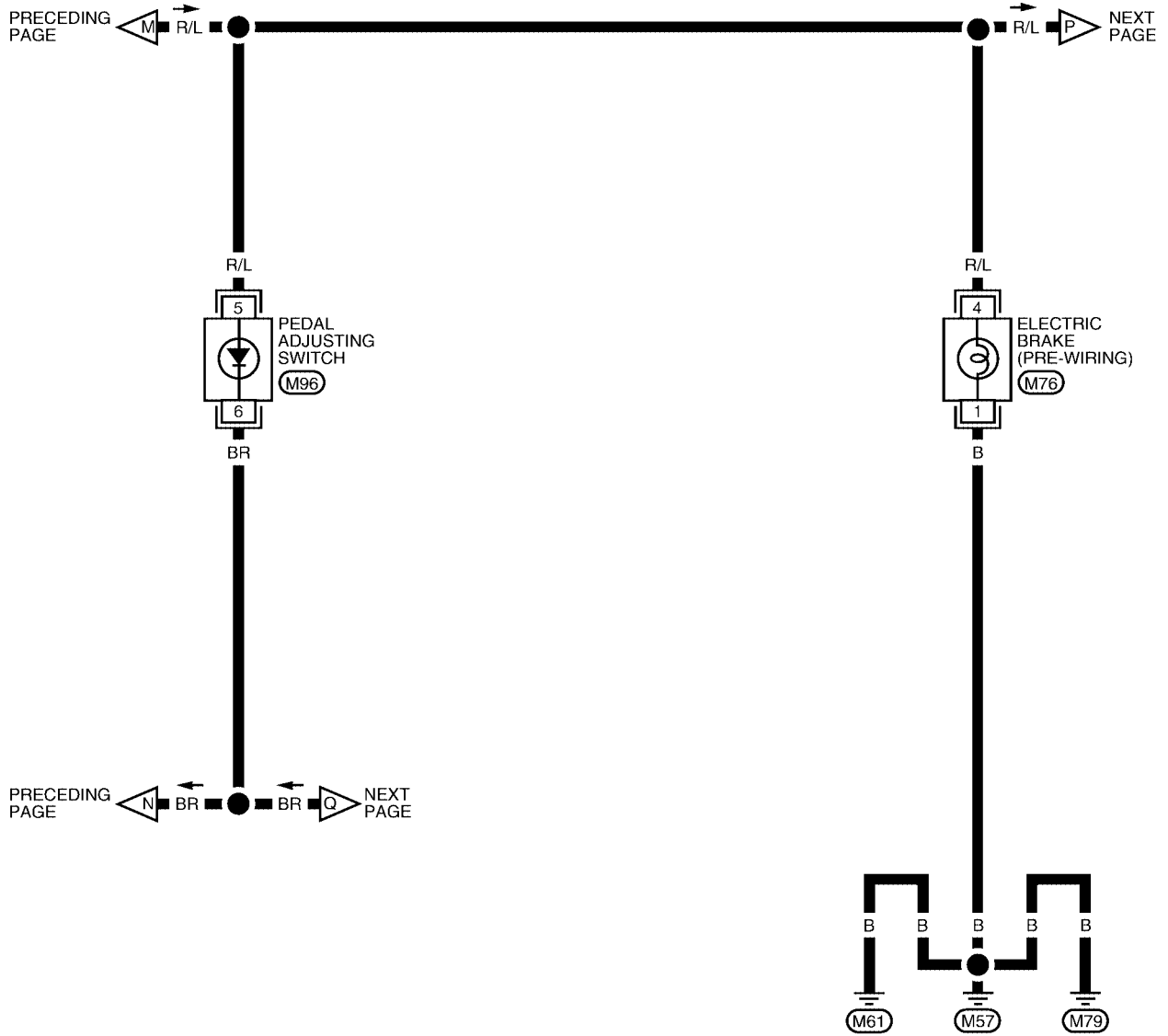

A  
B  
C  
D  
E  
F  
G  
H  
I  
J  
K  
L  
M

LT

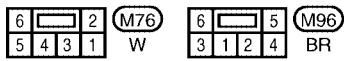

WKWA2459E

# ILLUMINATION

LT-ILL-08

⬡HS⬡ : WITH HEATED SEATS  
 ⬡FS⬡ : FLOOR SHIFT

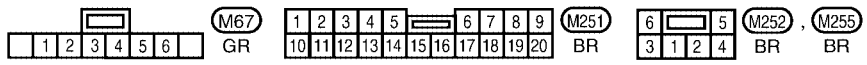
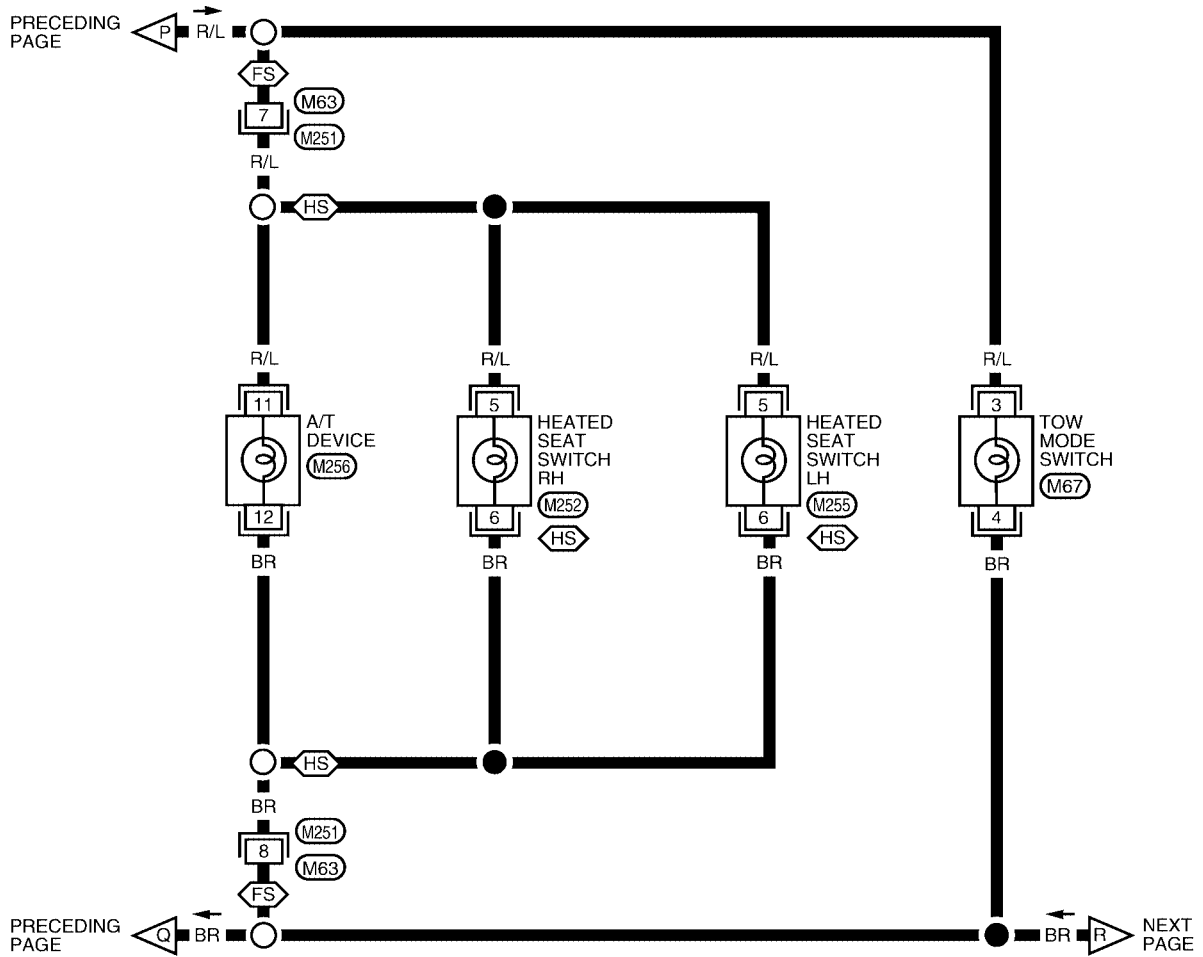

WKWA2460E

# ILLUMINATION

LT-ILL-09

— : DATA LINE

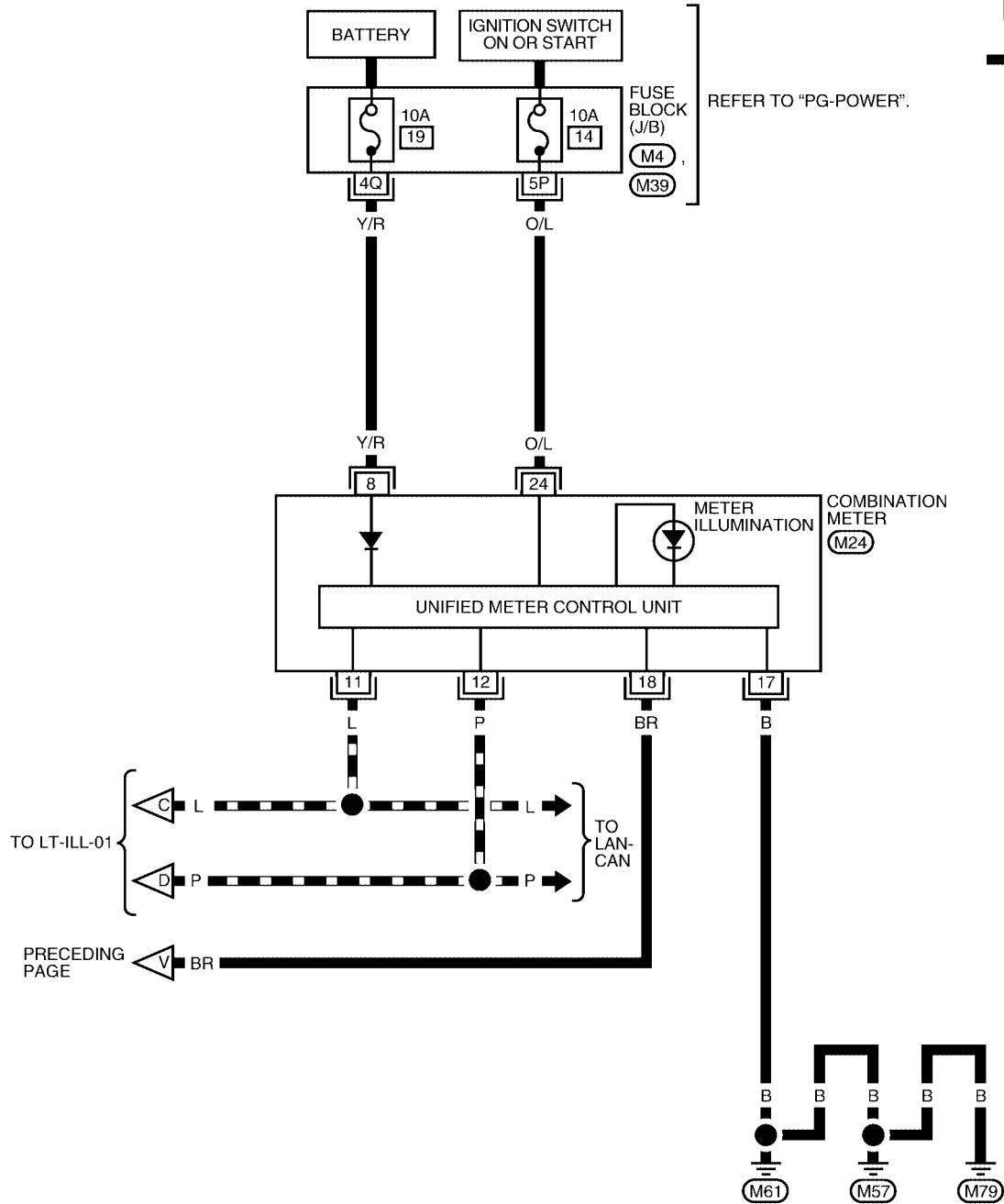

A  
B  
C  
D  
E  
F  
G  
H  
I  
J  
LT  
L  
M

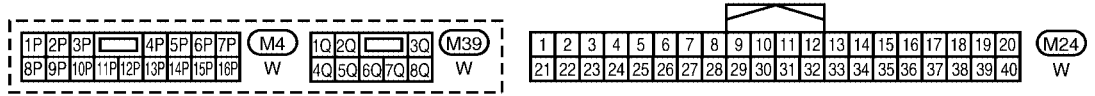

WKWA2435E

# ILLUMINATION

## Removal and Installation of Illumination Control Switch

EKS00ACK

### REMOVAL

1. Remove cluster lid A. Refer to [IP-13, "COMBINATION METER"](#).
2. Carefully pry tabs and remove illumination control switch from cluster lid A.

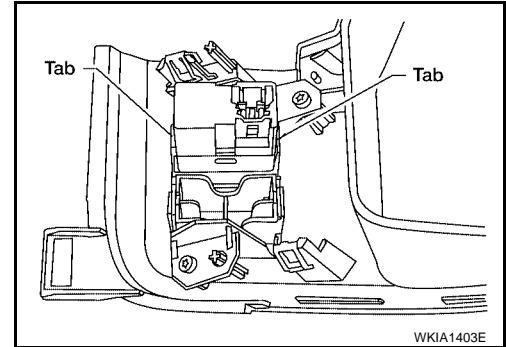

### INSTALLATION

Installation is in the reverse order of removal.

# BULB SPECIFICATIONS

## BULB SPECIFICATIONS

PF2:26297

### Headlamp

EKS00ACL

Item	Wattage (W)*
Low	51 (HB4)
High	60 (HB3)

\*: Always check with the Parts Department for the latest parts information.

### Exterior Lamp

EKS00ACM

Item	Wattage (W)*	
Front combination lamp	Turn signal lamp/parking lamp	27/8
	Side marker	3.8
Rear combination lamp	Stop/Tail lamp	27/7
	Turn signal lamp	27
	Back-up lamp	18
	Cargo lamp (tailgate)	16
Fog lamp	37.5	
License plate lamp	5	
High-mounted stop lamp	*	
Cargo lamp (in high-mounted stop lamp)	16	

\*: Always check with the Parts Department for the latest parts information.

### Interior Lamp/Illumination

EKS00ACN

Item	Wattage (W)*
Glove box lamp	3.4
Room/Map lamp	8
A/T device lamp	3
Foot lamp	3.4
Step lamp	3.8
Vanity lamp	1.32
Personal lamp	5
Puddle lamp	8

\*: Always check with the Parts Department for the latest parts information.

# BULB SPECIFICATIONS

---