

SECTION **AT**

AUTOMATIC TRANSMISSION

A
B
AT

CONTENTS

INDEX FOR DTC	5	How To Perform Trouble Diagnosis For Quick and	F
Alphabetical Index	5	Accurate Repair	45
DTC No. Index	6	A/T Electrical Parts Location	50
PRECAUTIONS	7	Circuit Diagram	51
Precautions for Supplemental Restraint System		Inspections Before Trouble Diagnosis	52
(SRS) "AIR BAG" and "SEAT BELT PRE-TEN-		Check Before Engine is Started	56
SIONER"	7	Check at Idle	56
Precautions for On Board Diagnostic (OBD) System		Cruise Test - Part 1	57
of A/T and Engine	7	Cruise Test - Part 2	59
Precautions	8	Cruise Test - Part 3	60
Service Notice or Precautions	9	Vehicle Speed When Shifting Gears	62
Wiring Diagrams and Trouble Diagnosis	9	Vehicle Speed When Performing and Releasing	
PREPARATION	10	Complete Lock-up	62
Special Service Tools	10	Vehicle Speed When Performing and Releasing	
Commercial Service Tools	11	Slip Lock-up	62
A/T FLUID	12	Symptom Chart	63
Changing A/T Fluid	12	TCM Input/Output Signal Reference Values	84
Checking A/T Fluid	12	CONSULT-II FUNCTION (A/T)	85
A/T Fluid Cooler Cleaning	12	DTC U1000 CAN COMMUNICATION LINE	97
A/T CONTROL SYSTEM	15	Description	97
Cross-Sectional View (2WD models)	15	On Board Diagnosis Logic	97
Cross-Sectional View (4WD models)	16	Possible Cause	97
Shift Mechanism	17	DTC Confirmation Procedure	97
TCM Function	30	Wiring Diagram — AT — CAN	98
CAN Communication	32	Diagnostic Procedure	99
Input/Output Signal of TCM	32	DTC P0615 START SIGNAL CIRCUIT	100
Line Pressure Control	33	Description	100
Shift Control	34	CONSULT-II Reference Value	100
Lock-Up Control	35	On Board Diagnosis Logic	100
Engine Brake Control	37	Possible Cause	100
Control Valve	37	DTC Confirmation Procedure	100
ON BOARD DIAGNOSTIC (OBD) SYSTEM	39	Wiring Diagram — AT — STSIG	101
Introduction	39	Diagnostic Procedure	102
OBD-II Function for A/T System	39	DTC P0700 TCM	104
One or Two Trip Detection Logic of OBD-II	39	Description	104
OBD-II Diagnostic Trouble Code (DTC)	39	On Board Diagnosis Logic	104
Malfunction Indicator Lamp (MIL)	42	Possible Cause	104
TROUBLE DIAGNOSIS	43	DTC Confirmation Procedure	104
DTC Inspection Priority Chart	43	Diagnostic Procedure	104
Fail-Safe	43	DTC P0705 PARK/NEUTRAL POSITION SWITCH	105

D
E
F
G
H
I
J
K
L
M

Description	105	DTC P1705 THROTTLE POSITION SENSOR	124
CONSULT-II Reference Value	105	Description	124
On Board Diagnosis Logic	105	CONSULT-II Reference Value	124
Possible Cause	105	On Board Diagnosis Logic	124
DTC Confirmation Procedure	105	Possible Cause	124
Wiring Diagram — AT — PNP/SW	106	DTC Confirmation Procedure	124
Diagnostic Procedure	107	Diagnostic Procedure	125
DTC P0720 VEHICLE SPEED SENSOR A/T (REVOLUTION SENSOR)	109	DTC P1710 A/T FLUID TEMPERATURE SENSOR CIRCUIT	127
Description	109	Description	127
CONSULT-II Reference Value	109	CONSULT-II Reference Value	127
On Board Diagnosis Logic	109	On Board Diagnosis Logic	127
Possible Cause	109	Possible Cause	127
DTC Confirmation Procedure	109	DTC Confirmation Procedure	127
Wiring Diagram — AT — VSSA/T	111	Wiring Diagram — AT — FTS	128
Diagnostic Procedure	112	Diagnostic Procedure	129
DTC P0725 ENGINE SPEED SIGNAL	114	Component Inspection	131
Description	114	DTC P1716 TURBINE REVOLUTION SENSOR ...	132
CONSULT-II Reference Value	114	Description	132
On Board Diagnosis Logic	114	CONSULT-II Reference Value	132
Possible Cause	114	On Board Diagnosis Logic	132
DTC Confirmation Procedure	114	Possible Cause	132
Diagnostic Procedure	114	DTC Confirmation Procedure	132
DTC P0740 TORQUE CONVERTER CLUTCH SOLENOID VALVE	116	Diagnostic Procedure	133
Description	116	DTC P1721 VEHICLE SPEED SENSOR MTR	134
CONSULT-II Reference Value	116	Description	134
On Board Diagnosis Logic	116	CONSULT-II Reference Value	134
Possible Cause	116	On Board Diagnosis Logic	134
DTC Confirmation Procedure	116	Possible Cause	134
Diagnostic Procedure	117	DTC Confirmation Procedure	134
DTC P0744 A/T TCC S/V FUNCTION (LOCK-UP)	118	Diagnostic Procedure	135
Description	118	DTC P1730 A/T INTERLOCK	136
CONSULT-II Reference Value	118	Description	136
On Board Diagnosis Logic	118	On Board Diagnosis Logic	136
Possible Cause	118	Possible Cause	136
DTC Confirmation Procedure	118	DTC Confirmation Procedure	136
Diagnostic Procedure	119	Judgement of A/T Interlock	136
DTC P0745 LINE PRESSURE SOLENOID VALVE	120	Diagnostic Procedure	137
Description	120	DTC P1731 A/T 1ST ENGINE BRAKING	139
CONSULT-II Reference Value	120	Description	139
On Board Diagnosis Logic	120	CONSULT-II Reference Value	139
Possible Cause	120	On Board Diagnosis Logic	139
DTC Confirmation Procedure	120	Possible Cause	139
Diagnostic Procedure	121	DTC Confirmation Procedure	139
DTC P1702 TRANSMISSION CONTROL MODULE (RAM)	122	Diagnostic Procedure	140
Description	122	DTC P1752 INPUT CLUTCH SOLENOID VALVE	141
On Board Diagnosis Logic	122	Description	141
Possible Cause	122	CONSULT-II Reference Value	141
DTC Confirmation Procedure	122	On Board Diagnosis Logic	141
Diagnostic Procedure	122	Possible Cause	141
DTC P1703 TRANSMISSION CONTROL MODULE (ROM)	123	DTC Confirmation Procedure	141
Description	123	Diagnostic Procedure	142
On Board Diagnosis Logic	123	DTC P1754 INPUT CLUTCH SOLENOID VALVE FUNCTION	143
Possible Cause	123	Description	143
DTC Confirmation Procedure	123	CONSULT-II Reference Value	143
Diagnostic Procedure	123	On Board Diagnosis Logic	143
		Possible Cause	143

DTC Confirmation Procedure	143	CONSULT-II Reference Value	159	
Diagnostic Procedure	144	On Board Diagnosis Logic	159	A
DTC P1757 FRONT BRAKE SOLENOID VALVE . 145		Possible Cause	159	
Description	145	DTC Confirmation Procedure	159	
CONSULT-II Reference Value	145	Diagnostic Procedure	160	B
On Board Diagnosis Logic	145	DTC P1815 MANUAL MODE SWITCH 161		
Possible Cause	145	Description	161	AT
DTC Confirmation Procedure	145	CONSULT-II Reference Value in Data Monitor Mode	161	
Diagnostic Procedure	146	On Board Diagnosis Logic	161	
DTC P1759 FRONT BRAKE SOLENOID VALVE		Possible Cause	161	
FUNCTION 147		DTC Confirmation Procedure	161	D
Description	147	Wiring Diagram — AT — MMSW	162	
CONSULT-II Reference Value	147	Diagnostic Procedure	163	E
On Board Diagnosis Logic	147	Component Inspection	164	
Possible Cause	147	Position Indicator Lamp	164	
DTC Confirmation Procedure	147	DTC P1841 ATF PRESSURE SWITCH 1 166		
Diagnostic Procedure	148	Description	166	F
DTC P1762 DIRECT CLUTCH SOLENOID VALVE 149		CONSULT-II Reference Value	166	
Description	149	On Board Diagnosis Logic	166	
CONSULT-II Reference Value	149	Possible Cause	166	G
On Board Diagnosis Logic	149	DTC Confirmation Procedure	166	
Possible Cause	149	Diagnostic Procedure	167	
DTC Confirmation Procedure	149	DTC P1843 ATF PRESSURE SWITCH 3 168		
Diagnostic Procedure	150	Description	168	H
DTC P1764 DIRECT CLUTCH SOLENOID VALVE		CONSULT-II Reference Value	168	
FUNCTION 151		On Board Diagnosis Logic	168	
Description	151	Possible Cause	168	I
CONSULT-II Reference Value	151	DTC Confirmation Procedure	168	
On Board Diagnosis Logic	151	Diagnostic Procedure	169	
Possible Cause	151	DTC P1845 ATF PRESSURE SWITCH 5 170		J
DTC Confirmation Procedure	151	Description	170	
Diagnostic Procedure	152	CONSULT-II Reference Value	170	
DTC P1767 HIGH AND LOW REVERSE CLUTCH		On Board Diagnosis Logic	170	
SOLENOID VALVE 153		Possible Cause	170	K
Description	153	DTC Confirmation Procedure	170	
CONSULT-II Reference Value	153	Diagnostic Procedure	171	
On Board Diagnosis Logic	153	DTC P1846 ATF PRESSURE SWITCH 6 172		L
Possible Cause	153	Description	172	
DTC Confirmation Procedure	153	CONSULT-II Reference Value	172	
Diagnostic Procedure	154	On Board Diagnosis Logic	172	
DTC P1769 HIGH AND LOW REVERSE CLUTCH		Possible Cause	172	M
SOLENOID VALVE FUNCTION 155		DTC Confirmation Procedure	172	
Description	155	Diagnostic Procedure	173	
CONSULT-II Reference Value	155	MAIN POWER SUPPLY AND GROUND CIRCUIT. 174		
On Board Diagnosis Logic	155	Wiring Diagram — AT — MAIN	174	
Possible Cause	155	Diagnostic Procedure	175	
DTC Confirmation Procedure	155	TOW MODE SWITCH 178		
Diagnostic Procedure	156	Description	178	
DTC P1772 LOW COAST BRAKE SOLENOID		Wiring Diagram — AT — TMSW	179	
VALVE 157		Diagnostic Procedure	180	
Description	157	CLOSED THROTTLE POSITION AND WIDE OPEN		
CONSULT-II Reference Value	157	THROTTLE POSITION CIRCUIT 181		
On Board Diagnosis Logic	157	CONSULT-II Reference Value	181	
Possible Cause	157	Diagnostic Procedure	181	
DTC Confirmation Procedure	157	BRAKE SIGNAL CIRCUIT 182		
Diagnostic Procedure	158	CONSULT-II Reference Value	182	
DTC P1774 LOW COAST BRAKE SOLENOID		Diagnostic Procedure	182	
VALVE FUNCTION 159		TROUBLE DIAGNOSIS FOR SYMPTOMS 183		
Description	159			

Wiring Diagram — AT — NONDTC	183	KEY INTERLOCK CABLE	248
AT CHECK Indicator Lamp does not come on	186	Components	248
Engine Cannot Be Started In “P” or “N” Position .	186	Removal	248
In “P” Position, Vehicle Moves When Pushed	187	Installation	249
In “N” Position, Vehicle Moves	188	ON-VEHICLE SERVICE	250
Large Shock (“N” to “D” Position)	189	Control Valve With TCM and A/T Fluid Temperature	
Vehicle Does Not Creep Backward In “R” Position	192	Sensor 2	250
Vehicle Does Not Creep Forward In “D” Position .	195	Rear Oil Seal	262
Vehicle Cannot Be Started From D1	197	AIR BREATHER HOSE	263
A/T Does Not Shift: D1 → D2	200	Removal and Installation	263
A/T Does Not Shift: D2 → D3	202	TRANSMISSION ASSEMBLY	265
A/T Does Not Shift: D3 → D4	204	Removal and Installation (4x2)	265
A/T Does Not Shift: D4 → D5	207	Removal and Installation (4x4)	268
A/T Does Not Perform Lock-up	209	OVERHAUL	271
A/T Does Not Hold Lock-up Condition	211	Components	271
Lock-up Is Not Released	213	Oil Channel	279
Engine Speed Does Not Return To Idle	214	Locations of Adjusting Shims, Needle Bearings,	
Cannot Be Changed to Manual Mode (Column Shift)	215	Thrust Washers and Snap Rings	281
		DISASSEMBLY	283
A/T Does Not Shift: 5th gear → 4th gear (Floor Shift		Disassembly	283
Models)	215	REPAIR FOR COMPONENT PARTS	300
A/T Does Not Shift: 5th gear → 4th gear (Column		Oil Pump	300
Shift Models)	218	Front Sun Gear, 3rd One-Way Clutch	302
A/T Does Not Shift: 4th gear → 3rd gear (Floor Shift		Front Carrier, Input Clutch, Rear Internal Gear	305
Models)	220	Mid Sun Gear, Rear Sun Gear, High and Low	
A/T Does Not Shift: 4th gear → 3rd gear (Column		Reverse Clutch Hub	310
Shift Models)	222	High and Low Reverse Clutch	315
A/T Does Not Shift: 3rd gear → 2nd gear (Floor Shift		Direct Clutch	317
Models)	224	ASSEMBLY	319
A/T Does Not Shift: 3rd gear → 2nd gear (Column		Assembly (1)	319
Shift Models)	226	Adjustment	332
A/T Does Not Shift: 2nd gear → 1st gear (Floor Shift		Assembly (2)	334
Models)	228	SERVICE DATA AND SPECIFICATIONS (SDS) ...	341
A/T Does Not Shift: 2nd gear → 1st gear (Column		General Specifications	341
Shift Models)	231	Vehicle Speed When Shifting Gears	341
Vehicle Does Not Decelerate By Engine Brake ...	233	Vehicle Speed When Performing and Releasing	
SHIFT CONTROL SYSTEM	236	Complete Lock-up	342
Control Device Removal and Installation	236	Vehicle Speed When Performing and Releasing	
Adjustment of A/T Position	238	Slip Lock-up	342
Checking of A/T Position	238	Stall Speed	342
A/T SHIFT LOCK SYSTEM	239	Line Pressure	342
Description	239	A/T Fluid Temperature Sensor	342
Shift Lock System Electrical Parts Location	239	Turbine Revolution Sensor	342
Wiring Diagram — A/T — SHIFT	241	Vehicle Speed Sensor A/T (Revolution Sensor) ..	342
Shift Lock Control Unit Reference Values	243	Reverse brake	343
DIAGNOSTIC PROCEDURE	244	Total End Play	343
Component Inspection	246		

INDEX FOR DTC

PFP:00024

ECS00AVO

INDEX FOR DTC

Alphabetical Index

NOTE:

If DTC U1000 is displayed with other DTC, first perform the trouble diagnosis for DTC U1000. Refer to [AT-97](#).

Items (CONSULT-II screen terms)	DTC		Reference page
	OBD-II	Except OBD-II	
	CONSULT-II GST (*1)	CONSULT-II only "A/T"	
A/T 1ST E/BRAKING	—	P1731	AT-139
ATF PRES SW 1/CIRC	—	P1841	AT-166
ATF PRES SW 3/CIRC	—	P1843	AT-168
ATF PRES SW 5/CIRC	—	P1845	AT-170
ATF PRES SW 6/CIRC	—	P1846	AT-172
A/T INTERLOCK	P1730	P1730	AT-136
A/T TCC S/V FNCTN	P0744	P0744	AT-118
ATF TEMP SEN/CIRC	P0710	P1710	AT-127
CAN COMM CIRCUIT	U1000	U1000	AT-97
D/C SOLENOID/CIRC	P1762	P1762	AT-149
D/C SOLENOID FNCTN	P1764 (*2)	P1764	AT-151
ENGINE SPEED SIG	—	P0725	AT-114
FR/B SOLENOID/CIRC	P1757	P1757	AT-145
FR/B SOLENOID FNCT	P1759	P1759	AT-147
HLR/C SOL/CIRC	P1767	P1767	AT-153
HLR/C SOL FNCTN	P1769 (*2)	P1769	AT-155
I/C SOLENOID/CIRC	P1752	P1752	AT-141
I/C SOLENOID FNCTN	P1754 (*2)	P1754	AT-143
L/PRESS SOL/CIRC	P0745	P0745	AT-120
LC/B SOLENOID/CIRC	P1772	P1772	AT-157
LC/B SOLENOID FNCT	P1774	P1774	AT-159
MANU MODE SW/CIR	—	P1815	AT-161
PNP SW/CIRC	P0705	P0705	AT-105
STARTER RELAY/CIRC	—	P0615	AT-100
TCC SOLENOID/CIRC	P0740	P0740	AT-116
TCM	P0700	P0700	AT-104
TCM-RAM	—	P1702	AT-122
TCM-ROM	—	P1703	AT-123
TP SEN/CIRC A/T	—	P1705	AT-124
TURBINE REV S/CIRC	P1716	P1716	AT-132
VEH SPD SE/CIR·MTR	—	P1721	AT-134
VEH SPD SEN/CIR AT	P0720	P0720	AT-109

*1: These numbers are prescribed by SAE J2012.

*2: These malfunctions cannot be displayed MIL if another malfunction is assigned to MIL.

INDEX FOR DTC

ECS00AVP

DTC No. Index

NOTE:

If DTC U1000 is displayed with other DTC, first perform the trouble diagnosis for DTC U1000. Refer to [AT-97](#).

DTC		Items (CONSULT-II screen terms)	Reference page
OBD-II	Except OBD-II		
CONSULT-II GST (*1)	CONSULT-II only "A/T"		
—	P0615	STARTER RELAY/CIRC	AT-100
P0700	P0700	TCM	AT-104
P0705	P0705	PNP SW/CIRC	AT-105
P0710	P1710	ATF TEMP SEN/CIRC	AT-127
P0720	P0720	VEH SPD SEN/CIR AT	AT-109
—	P0725	ENGINE SPEED SIG	AT-114
P0740	P0740	TCC SOLENOID/CIRC	AT-116
P0744	P0744	A/T TCC S/V FNCTN	AT-118
P0745	P0745	L/PRESS SOL/CIRC	AT-120
—	P1702	TCM-RAM	AT-122
—	P1703	TCM-ROM	AT-123
—	P1705	TP SEN/CIRC A/T	AT-124
P1716	P1716	TURBINE REV S/CIRC	AT-132
—	P1721	VEH SPD SE/CIR-MTR	AT-134
P1730	P1730	A/T INTERLOCK	AT-136
—	P1731	A/T 1ST E/BRAKING	AT-139
P1752	P1752	I/C SOLENOID/CIRC	AT-141
P1754 (*2)	P1754	I/C SOLENOID FNCTN	AT-143
P1757	P1757	FR/B SOLENOID/CIRC	AT-145
P1759 (*2)	P1759	FR/B SOLENOID FNCT	AT-147
P1762	P1762	D/C SOLENOID/CIRC	AT-149
P1764 (*2)	P1764	D/C SOLENOID FNCTN	AT-151
P1767	P1767	HLR/C SOL/CIRC	AT-153
P1769	P1769	HLR/C SOL FNCTN	AT-155
P1772	P1772	LC/B SOLENOID/CIRC	AT-157
P1774	P1774	LC/B SOLENOID FNCT	AT-159
—	P1815	MANU MODE SW/CIR	AT-161
—	P1841	ATF PRES SW 1/CIRC	AT-166
—	P1843	ATF PRES SW 3/CIRC	AT-168
—	P1845	ATF PRES SW 5/CIRC	AT-170
—	P1846	ATF PRES SW 6/CIRC	AT-172
U1000	U1000	CAN COMM CIRCUIT	AT-97

*1: These numbers are prescribed by SAE J2012.

*2: These malfunctions cannot be displayed MIL if another malfunction is assigned to MIL.

PRECAUTIONS

PRECAUTIONS

PF0:00001

Precautions for Supplemental Restraint System (SRS) “AIR BAG” and “SEAT BELT PRE-TENSIONER”

ECS00CLV

The Supplemental Restraint System such as “AIR BAG” and “SEAT BELT PRE-TENSIONER”, used along with a front seat belt, helps to reduce the risk or severity of injury to the driver and front passenger for certain types of collision. This system includes seat belt switch inputs and dual stage front air bag modules. The SRS system uses the seat belt switches to determine the front air bag deployment, and may only deploy one front air bag, depending on the severity of a collision and whether the front occupants are belted or unbelted. Information necessary to service the system safely is included in the SRS and SB section of this Service Manual.

WARNING:

- To avoid rendering the SRS inoperative, which could increase the risk of personal injury or death in the event of a collision which would result in air bag inflation, all maintenance must be performed by an authorized NISSAN/INFINITI dealer.
- Improper maintenance, including incorrect removal and installation of the SRS, can lead to personal injury caused by unintentional activation of the system. For removal of Spiral Cable and Air Bag Module, see the SRS section.
- Do not use electrical test equipment on any circuit related to the SRS unless instructed to in this Service Manual. SRS wiring harnesses can be identified by yellow and/or orange harnesses or harness connectors.

Precautions for On Board Diagnostic (OBD) System of A/T and Engine

ECS00AVR

The ECM has an on board diagnostic system. It will light up the malfunction indicator lamp (MIL) to warn the driver of a malfunction causing emission deterioration.

CAUTION:

- Be sure to turn the ignition switch “OFF” and disconnect the negative battery cable before any repair or inspection work. The open/short circuit of related switches, sensors, solenoid valves, etc. Will cause the MIL to light up.
- Be sure to connect and lock the connectors securely after work. A loose (unlocked) connector will cause the MIL to light up due to an open circuit. (Be sure the connector is free from water, grease, dirt, bent terminals, etc.)
- Be sure to route and secure the harnesses properly after work. Interference of the harness with a bracket, etc. May cause the MIL to light up due to a short circuit.
- Be sure to connect rubber tubes properly after work. A misconnected or disconnected rubber tube may cause the MIL to light up due to a malfunction of the EGR system or fuel injection system, etc.
- Be sure to erase the unnecessary malfunction information (repairs completed) from the TCM and ECM before returning the vehicle to the customer.

PRECAUTIONS

ECS00AVS

Precautions

NOTE:

If any malfunctions occur in the RE5R05A model transmission, replace the entire transmission assembly.

- Before connecting or disconnecting the TCM harness connector, turn ignition switch "OFF" and disconnect negative battery cable. Because battery voltage is applied to TCM even if ignition switch is turned "OFF".

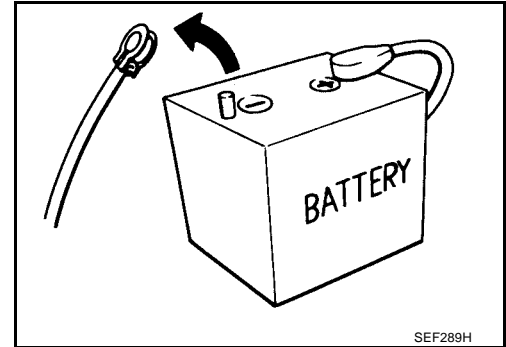

- After performing each TROUBLE DIAGNOSIS, perform "DTC (Diagnostic Trouble Code) CONFIRMATION PROCEDURE".
If the repair is completed the DTC should not be displayed in the "DTC CONFIRMATION PROCEDURE".

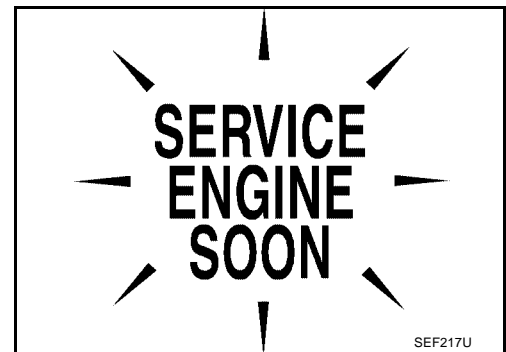

- Always use the specified brand of ATF. Refer to [MA-11, "RECOMMENDED FLUIDS AND LUBRICANTS"](#).
- Use paper rags not cloth rags during work.
- After replacing the ATF, dispose of the waste oil using the methods prescribed by law, ordinance, etc.
- Before proceeding with disassembly, thoroughly clean the outside of the transmission. It is important to prevent the internal parts from becoming contaminated by dirt or other foreign matter.
- Disassembly should be done in a clean work area.
- Use lint-free cloth or towels for wiping parts clean. Common shop rags can leave fibers that could interfere with the operation of the transmission.
- Place disassembled parts in order for easier and proper assembly.
- All parts should be carefully cleaned with a general purpose, non-flammable solvent before inspection or reassembly.
- Gaskets, seals and O-rings should be replaced any time the transmission is disassembled.
- It is very important to perform functional tests whenever they are indicated.
- The valve body contains precision parts and requires extreme care when parts are removed and serviced. Place disassembled valve body parts in order for easier and proper assembly. Care will also prevent springs and small parts from becoming scattered or lost.
- Properly installed valves, sleeves, plugs, etc. will slide along bores in valve body under their own weight.
- Before assembly, apply a coat of recommended ATF to all parts. Apply petroleum jelly to protect O-rings and seals, or hold bearings and washers in place during assembly. Do not use grease.
- Extreme care should be taken to avoid damage to O-rings, seals and gaskets when assembling.
- Clean or replace ATF cooler if excessive foreign material is found in oil pan or clogging strainer. Refer to [AT-12, "A/T Fluid Cooler Cleaning"](#).
- After overhaul, refill the transmission with new ATF.
- When the A/T drain plug is removed, only some of the fluid is drained. Old A/T fluid will remain in torque converter and ATF cooling system.
Always follow the procedures under "Changing A/T Fluid" in the AT section when changing A/T fluid. Refer to [MA-23, "Changing A/T Fluid"](#), [MA-21, "Checking A/T Fluid"](#).

PRECAUTIONS

Service Notice or Precautions

ECS00AVT

ATF COOLER SERVICE

- If A/T fluid contains fictional material (clutches, bands, etc.), or if an A/T is repaired, overhauled, or replaced, inspect and clean the A/T fluid cooler mounted in the radiator or replace the radiator. Flush cooler lines with cleaning solvent and compressed air after repair. For A/T fluid cooler cleaning procedure, refer to [AT-12, "A/T Fluid Cooler Cleaning"](#) . For radiator replacement, refer to [CO-12, "REMOVAL"](#) .

CHECKING AND CHANGING A/T FLUID

- Increase ATF oil temperature to 80°C (176°F) first, then check and adjust oil level at 65°C (149°F).

NOTE:

The A/T has both water cooling and air cooling systems. The air cooling system has a bypass valve. When ATF oil temperature is at or below 50°C (122°F), it does not flow through the air cooled system. If A/T oil level is adjusted without flow throughout the entire system, the level will be 10mm lower than required. Therefore, all piping should be filled with oil when adjusting level.

OBD-II SELF-DIAGNOSIS

- A/T self-diagnosis is performed by the TCM in combination with the ECM. Refer to the table on [AT-87, "SELF-DIAGNOSTIC RESULT MODE"](#) for the indicator used to display each self-diagnostic result.
- The self-diagnostic results indicated by the MIL are automatically stored in both the ECM and TCM memories.

Always perform the procedure on [AT-40, "HOW TO ERASE DTC"](#) to complete the repair and avoid unnecessary blinking of the MIL.

For details of OBD-II, refer to [AT-39, "ON BOARD DIAGNOSTIC \(OBD\) SYSTEM"](#) .

- **Certain systems and components, especially those related to OBD, may use the new style slide-locking type harness connector. For description and how to disconnect, refer to [PG-69, "HARNESS CONNECTOR"](#) .**

Wiring Diagrams and Trouble Diagnosis

ECS00AVU

When you read wiring diagrams, refer to the following:

- [GI-14, "How to Read Wiring Diagrams"](#).
- [PG-4, "POWER SUPPLY ROUTING CIRCUIT"](#) for power distribution circuit.

When you perform trouble diagnosis, refer to the following:

- [GI-9, "How to Follow Trouble Diagnoses"](#).
- [GI-27, "How to Perform Efficient Diagnosis for an Electrical Incident"](#).

PREPARATION

PFP:00002

ECS00AVV

PREPARATION

Special Service Tools

The actual shapes of Kent-Moore tools may differ from those of special service tools illustrated here.

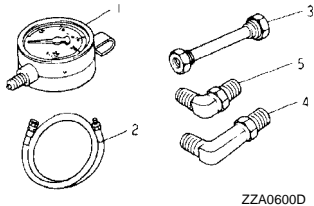
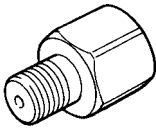
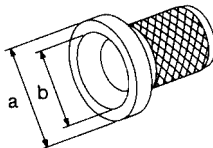
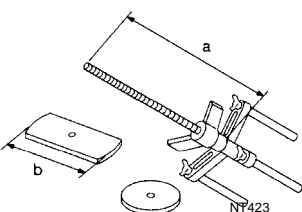
Tool number (Kent-Moore No.) Tool name	Description
ST2505S001 (J-34301-C) Oil pressure gauge set 1 ST25051001 (—) Oil pressure gauge 2 ST25052000 (—) Hose 3 ST25053000 (—) Joint pipe 4 ST25054000 (—) Adapter 5 ST25055000 (—) Adapter	 <p style="text-align: center;">ZZA0600D</p>
KV31103600 (J-45674) Joint pipe adapter (With ST25054000)	 <p style="text-align: center;">ZZA1227D</p>
ST33400001 (J-26082) Drift a: 60 mm (2.36 in) dia b: 47 mm (1.85 in) dia	 <p style="text-align: center;">NT086</p> <ul style="list-style-type: none"> ● Installing rear oil seal (2WD models) ● Installing oil pump housing oil seal
KV31102400 (J-34285 and J-34285-87) Clutch spring compressor a: 320 mm (12.60 in) b: 174 mm (6.85 in)	 <p style="text-align: center;">NT423</p>

PREPARATION

Tool number (Kent-Moore No.) Tool name	Description
ST25850000 (J-25721-A) Sliding hammer a: 179 mm (7.05 in) b: 70 mm (2.76 in) c: 40 mm (1.57 in) d: M12X1.75P	Remove oil pump assembly
— (J-47002) Transmission jack adapter kit 1. — (J-47002-2) Center bracket 2. — (J-47002-3) Adapter plate 3. — (J-47002-4) Adapter block	Assist in removal of transmission and transfer case as one assembly using only one transmission jack.

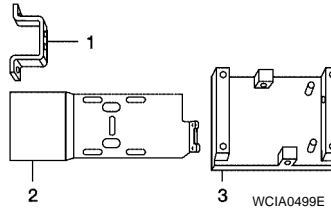
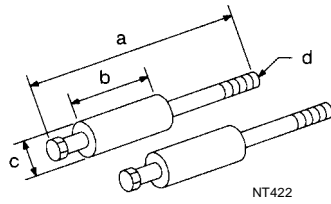

Commercial Service Tools

ECS00AVW

Tool name	Description
Power tool	Loosening bolts and nuts
Drift a: 22 mm (0.87 in)	Installing manual shaft seal
Drift a: 64 mm (2.52 in)	Installing rear oil seal (4WD models)

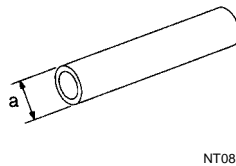
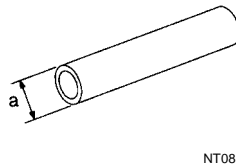
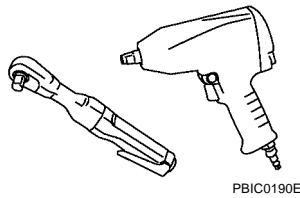

A/T FLUID

PFM:KLE40

Changing A/T Fluid

ECS00CCU

Refer to [MA-23, "Changing A/T Fluid"](#) .

Checking A/T Fluid

ECS00CCV

Refer to [MA-21, "Checking A/T Fluid"](#) .

A/T Fluid Cooler Cleaning

ECS00AVZ

Whenever an automatic transmission is repaired, overhauled, or replaced, the A/T fluid cooler mounted in the radiator must be inspected and cleaned.

Metal debris and friction material, if present, can become trapped in the A/T fluid cooler. This debris can contaminate the newly serviced A/T or, in severe cases, can block or restrict the flow of A/T fluid. In either case, malfunction of the newly serviced A/T may result.

Debris, if present, may build up as A/T fluid enters the cooler inlet. It will be necessary to back flush the cooler through the cooler outlet in order to flush out any built up debris.

A/T FLUID COOLER CLEANING PROCEDURE

1. Position an oil pan under the automatic transmission's inlet and outlet cooler hoses.
2. Identify the inlet and outlet fluid cooler hoses.
3. Disconnect the fluid cooler inlet and outlet rubber hoses from the steel cooler tubes or bypass valve.

NOTE:

Replace the cooler hoses if rubber material from the hose remains on the tube fitting.

4. Allow any A/T fluid that remains in the cooler hoses to drain into the oil pan.

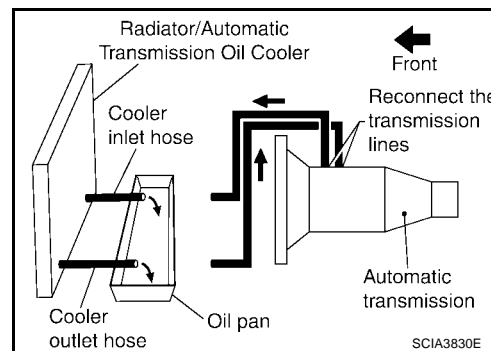

5. Insert the extension adapter hose of a can of Transmission Cooler Cleaner (Nissan P/N 999MP-AM006) into the cooler outlet hose.

CAUTION:

- Wear safety glasses and rubber gloves when spraying the Transmission Cooler Cleaner.
- Spray cooler cleaner only with adequate ventilation.
- Avoid contact with eyes and skin.
- Do not breath vapors or spray mist.

6. Hold the hose and can as high as possible and spray Transmission Cooler Cleaner in a continuous stream into the cooler outlet hose until fluid flows out of the cooler inlet hose for 5 seconds.
7. Insert the tip of an air gun into the end of the cooler outlet hose.
8. Wrap a shop rag around the air gun tip and of the cooler outlet hose.

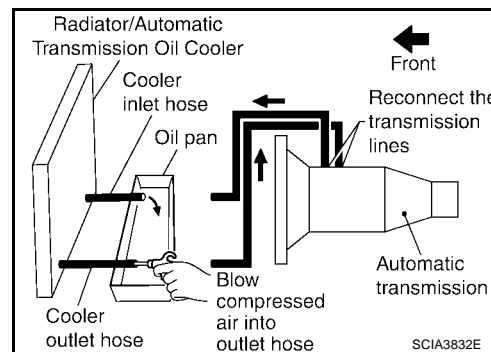
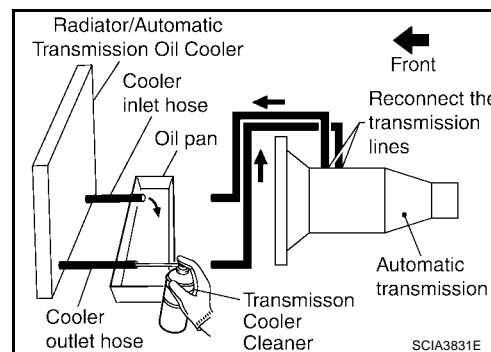

A/T FLUID

9. Blow compressed air regulated to 5 - 9 kg/cm² (70 - 130 psi) through the cooler outlet hose for 10 seconds to force out any remaining fluid.
10. Repeat steps 5 through 9 three additional times.
11. Position an oil pan under the banjo bolts that connect the fluid cooler steel lines to the transmission.
12. Remove the banjo bolts.
13. Flush each steel line from the cooler side back toward the transmission by spraying Transmission Cooler Cleaner in a continuous stream for 5 seconds.
14. Blow compressed air regulated to 5 - 9 kg/cm² (70 - 130 psi) through each steel line from the cooler side back toward the transmission for 10 seconds to force out any remaining fluid.
15. Ensure all debris is removed from the steel cooler lines.
16. Ensure all debris is removed from the banjo bolts and fittings.
17. Perform A/T fluid cooler inspection procedure. Refer to [AT-14, "A/T FLUID COOLER INSPECTION PROCEDURE"](#).

A/T FLUID COOLER DIAGNOSIS PROCEDURE

NOTE:

Insufficient cleaning of the cooler inlet hose exterior may lead to inaccurate debris identification.

1. Position an oil pan under the automatic transmission's inlet and outlet cooler hoses.
2. Clean the exterior and tip of the cooler inlet hose.
3. Insert the extension adapter hose of a can of Transmission Cooler Cleaner (Nissan P/N 999MP-AM006) into the cooler outlet hose.

CAUTION:

- Wear safety glasses and rubber gloves when spraying the Transmission Cooler Cleaner.
 - Spray cooler cleaner only with adequate ventilation.
 - Avoid contact with eyes and skin.
 - Do not breath vapors or spray mist.
4. Hold the hose and can as high as possible and spray Transmission Cooler Cleaner in a continuous stream into the cooler outlet hose until fluid flows out of the cooler inlet hose for 5 seconds.
 5. Tie a common white, basket-type coffee filter to the end of the cooler inlet hose.

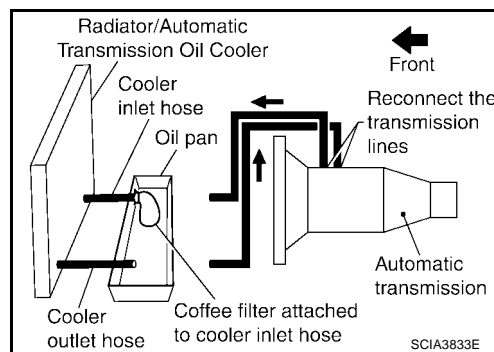
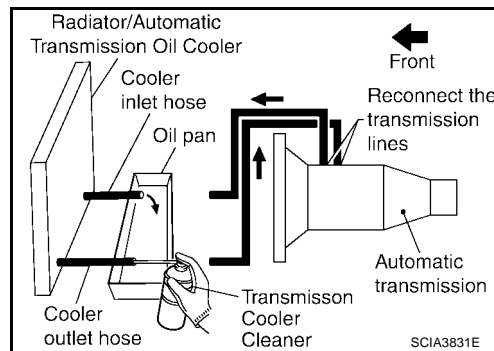

6. Insert the tip of an air gun into the end of the cooler outlet hose.
7. Wrap a shop rag around the air gun tip and end of cooler outlet hose.
8. Blow compressed air regulated to 5 - 9 kg/cm² (70 - 130 psi) through the cooler outlet hose to force any remaining A/T fluid into the coffee filter.
9. Remove the coffee filter from the end of the cooler inlet hose.
10. Perform A/T fluid cooler inspection procedure. [AT-14, "A/T FLUID COOLER INSPECTION PROCEDURE"](#).

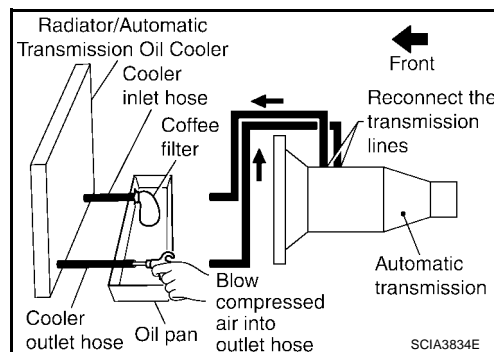

A/T FLUID

A/T FLUID COOLER INSPECTION PROCEDURE

1. Inspect the coffee filter for debris.
 - a. If small metal debris less than 1mm (0.040 in) in size or metal powder is found in the coffee filter, this is normal. If normal debris is found, the A/T fluid cooler/radiator can be re-used and the procedure is ended.

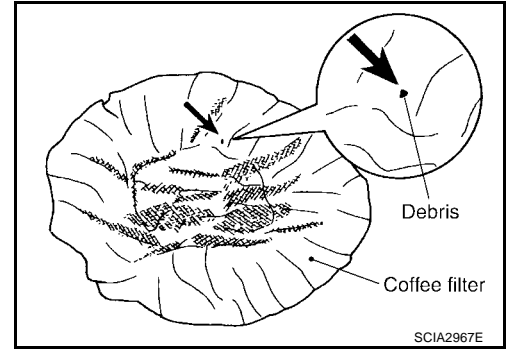

- b. If one or more pieces of debris are found that are over 1mm (0.040 in) in size and/or peeled clutch facing material is found in the coffee filter, the fluid cooler is not serviceable. The A/T fluid cooler/radiator must be replaced and the inspection procedure is ended. Refer to [CO-12, "RADIATOR"](#).

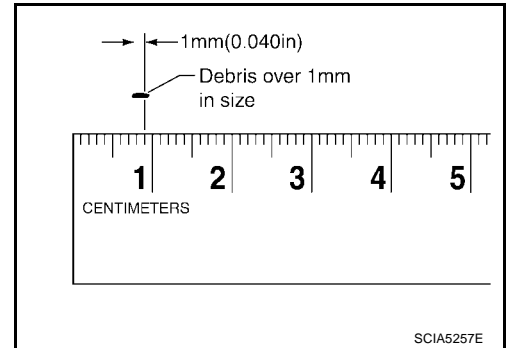

A/T FLUID COOLER FINAL INSPECTION

After performing all procedures, ensure that all remaining oil is cleaned from all components.

A/T CONTROL SYSTEM

PF3:31036

A/T CONTROL SYSTEM

Cross-Sectional View (2WD models)

ECS00AW0

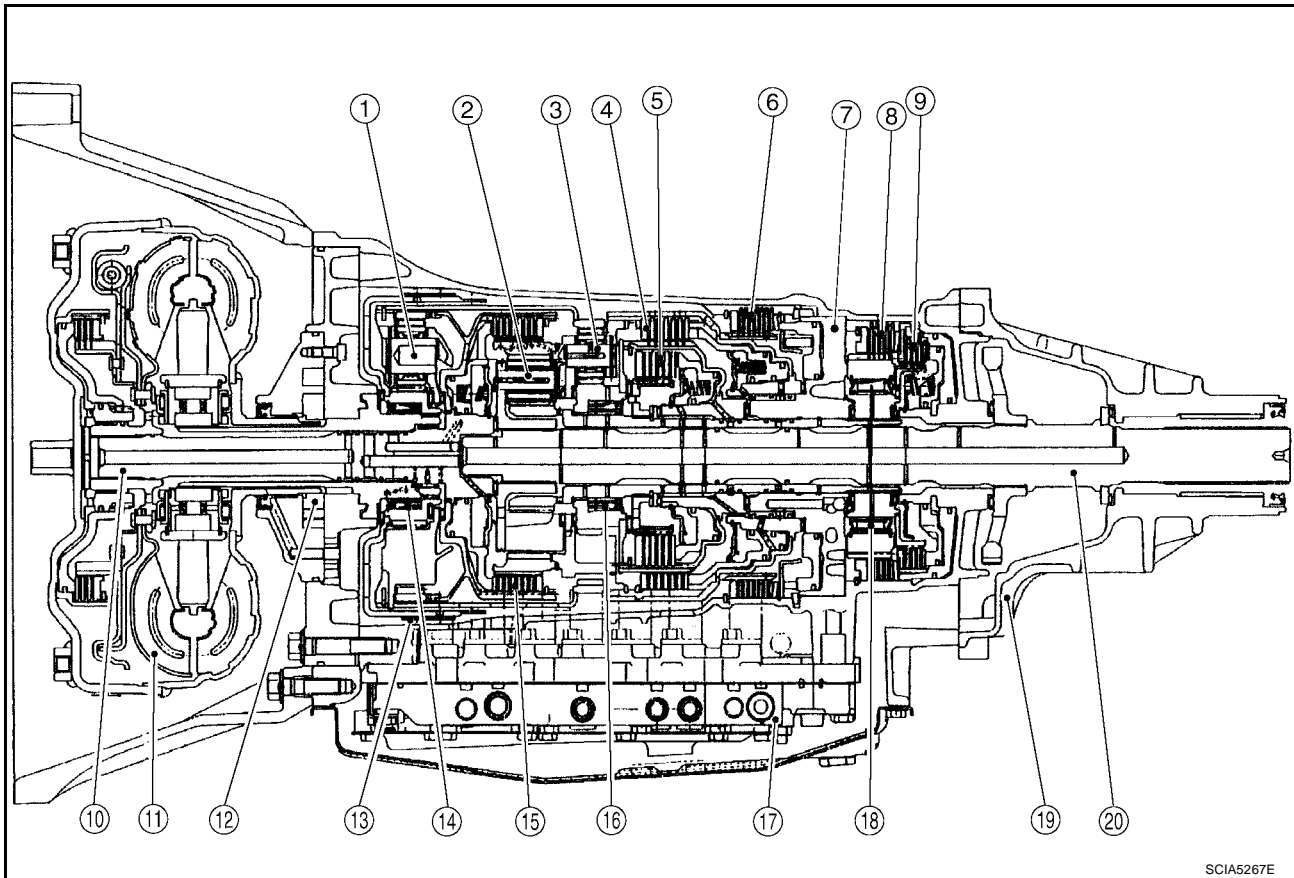

- | | | |
|-------------------------|------------------------------|----------------------------|
| 1. Front planetary gear | 2. Mid planetary gear | 3. Rear planetary gear |
| 4. Direct clutch | 5. High & low reverse clutch | 6. Reverse brake |
| 7. Drum support | 8. Forward brake | 9. Low coast brake |
| 10. Input shaft | 11. Torque converter | 12. Oil pump |
| 13. Front brake | 14. 3rd one-way clutch | 15. Input clutch |
| 16. 1st one-way clutch | 17. Control valve with TCM | 18. Forward one-way clutch |
| 19. Rear extension | 20. Output shaft | |

SCIA5267E

A

B

AT

D

E

F

G

H

I

J

K

L

M

A/T CONTROL SYSTEM

Cross-Sectional View (4WD models)

ECS00AW1

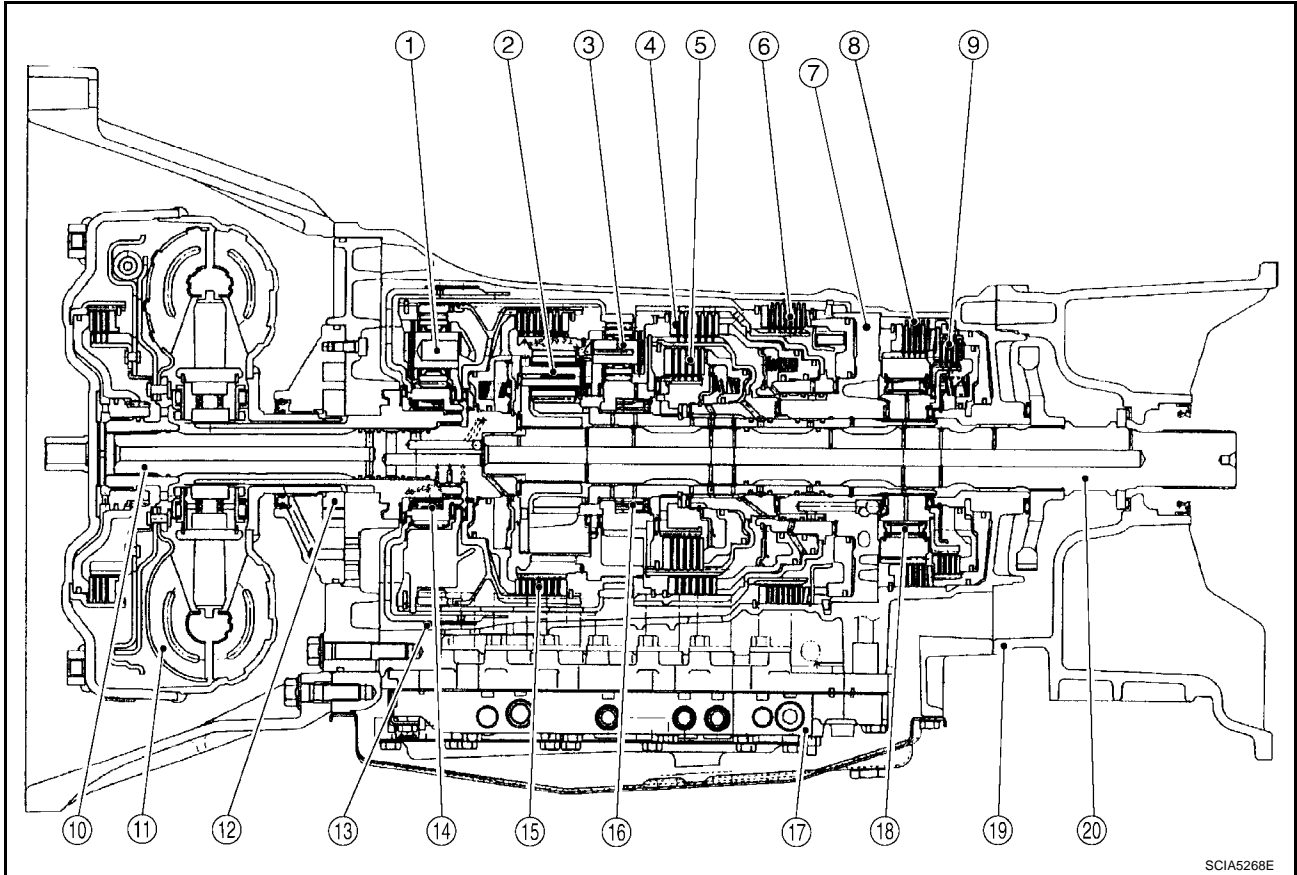

SCIA5268E

- | | | |
|-------------------------|------------------------------|----------------------------|
| 1. Front planetary gear | 2. Mid planetary gear | 3. Rear planetary gear |
| 4. Direct clutch | 5. High & low reverse clutch | 6. Reverse brake |
| 7. Drum support | 8. Forward brake | 9. Low coast brake |
| 10. Input shaft | 11. Torque converter | 12. Oil pump |
| 13. Front brake | 14. 3rd one-way clutch | 15. Input clutch |
| 16. 1st one-way clutch | 17. Control valve with TCM | 18. Forward one-way clutch |
| 19. Adapter case | 20. Output shaft | |

A/T CONTROL SYSTEM

ECS00AW2

Shift Mechanism

The automatic transmission uses compact dual planetary gear systems to improve power-transmission efficiency, simplify construction and reduce weight. It also employs an optimum shift control and super wide gear ratios. They improve starting performance and acceleration during medium and high-speed operation.

CONSTRUCTION

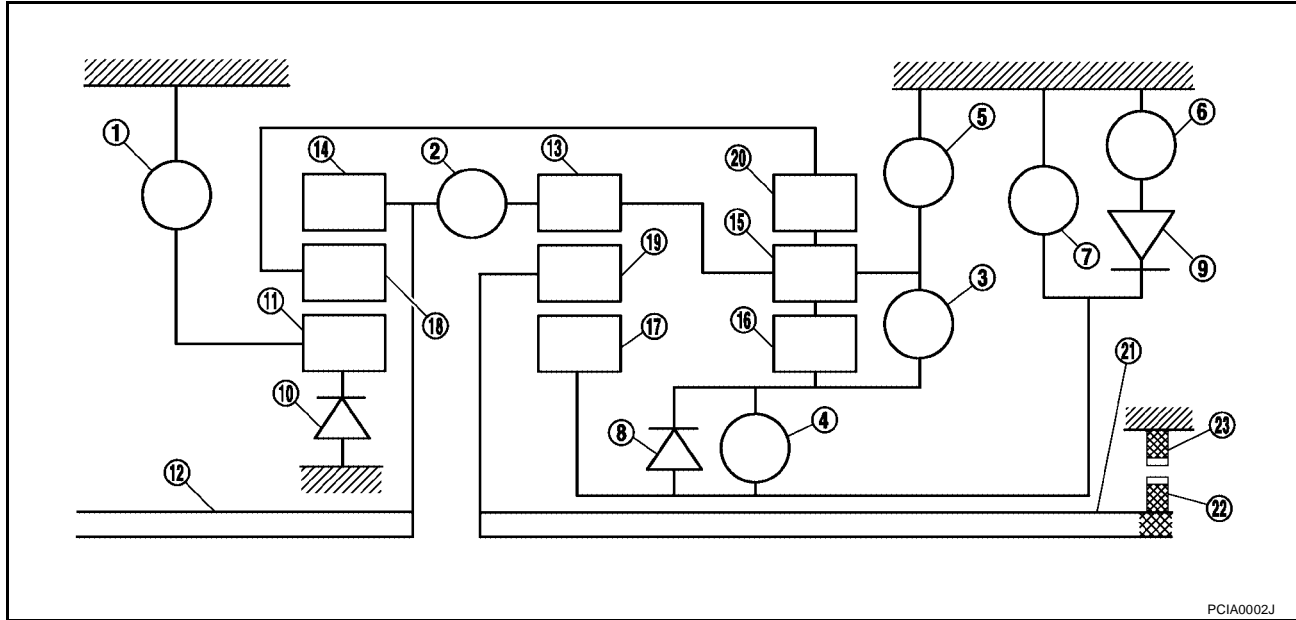

- | | | |
|--------------------------------|-------------------------|---------------------------|
| 1. Front brake | 2. Input clutch | 3. Direct clutch |
| 4. High and low reverse clutch | 5. Reverse brake | 6. Forward brake |
| 7. Low coast brake | 8. 1st one-way clutch | 9. Forward one-way clutch |
| 10. 3rd one-way clutch | 11. Front sun gear | 12. Input shaft |
| 13. Mid internal gear | 14. Front internal gear | 15. Rear carrier |
| 16. Rear sun gear | 17. Mid sun gear | 18. Front carrier |
| 19. Mid carrier | 20. Rear internal gear | 21. Output shaft |
| 22. Parking gear | 23. Parking pawl | |

FUNCTION OF CLUTCH AND BRAKE

Name of the Part	Abbreviation	Function
Front brake (1)	FR/B	Fastens the front sun gear (11).
Input clutch (2)	I/C	Connects the input shaft (12), the front internal gear (14) and the mid internal gear (13).
Direct clutch (3)	D/C	Connects the rear carrier (15) and the rear sun gear (16).
High and low reverse clutch (4)	HLR/C	Connects the mid sun gear (17) and the rear sun gear (16).
Reverse brake (5)	R/B	Fastens the rear carrier (15).
Forward brake (6)	F/B	Fastens the mid sun gear (17).
Low coast brake (7)	LC/B	Fastens the mid sun gear (17).
1st one-way clutch (8)	1st/O.C	Allows the rear sun gear (16) to turn freely forward relative to the mid sun gear (17) but fastens it for reverse rotation.
Forward one-way clutch (9)	F/O.C	Allows the mid sun gear (17) to turn freely in the forward direction but fastens it for reverse rotation.
3rd one-way clutch (10)	3rd/O.C	Allows the front sun gear (11) to turn freely in the forward direction but fastens it for reverse rotation.

A/T CONTROL SYSTEM

CLUTCH AND BAND CHART (FLOOR SHIFT MODELS)

Shift position		I/C	HLR/C	D/C	R/B	FR/B	LC/B	Fwd/B	1st OWC	Fwd OWC	3rd OWC	Remarks
P			△			△						PARK POSITION
R			○		○	○			☆		☆	REVERSE POSITION
N			△			△						NEUTRAL POSITION
D	1st		△*			△	△**	○	☆	☆	☆	Automatic shift 1⇔2⇔3⇔4⇔5
	2nd			○		△		○		☆	☆	
	3rd		○	○		○		△	★		☆	
	4th	○	○	○				△	★			
	5th	○	○			○		△	★		★	
4	1st		△*			△	△**	○	☆	☆	☆	Automatic shift 1⇔2⇔3⇔4
	2nd			○		△		○		☆	☆	
	3rd		○	○		○		△	★		☆	
	4th	○	○	○				△	★			
3	1st		△*			△	△**	○	☆	☆	☆	Automatic shift 1⇔2⇔3⇔4
	2nd			○		△		○		☆	☆	
	3rd		○	○		○		△	★		☆	
	4th	○	○	○				△	★			
2	1st		△*			△	△**	○	☆	☆	☆	Automatic shift 1⇔2⇔3⇔4
	2nd			○		○	○	○		☆	☆	
	3rd		○	○		○		△	★		☆	
	4th	○	○	○				△	★			
1	1st		○			○	○	○	☆	☆	☆	Locks (held stationary in 1st gear) 1⇔2⇔3⇔4
	2nd			○		○	○	○		☆	☆	
	3rd		○	○		○		△	★		☆	
	4th	○	○	○				△	★			

- ○—Operates
- ☆—Operates during “progressive” acceleration.
- ★—Operates and effects power transmission while coasting.
- △—Line pressure is applied but does not affect power transmission.
- △*—Operates under conditions shown in HLR/C Operating Condition
- △**—Operates under conditions shown in LC/B Operating Condition. Delay control is applied during D (4,3,2,1) ⇒N shift.

A/T CONTROL SYSTEM

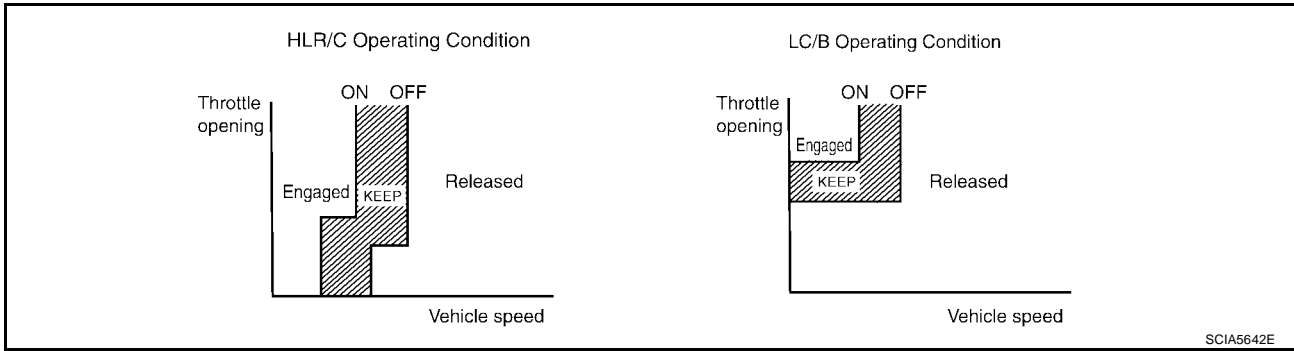

A

B

AT

D

E

F

G

H

I

J

K

L

M

A/T CONTROL SYSTEM

CLUTCH AND BAND CHART (COLUMN SHIFT MODELS)

Shift position		I/C	HLR/C	D/C	R/B	FR/B	LC/B	Fwd/B	1st OWC	Fwd OWC	3rd OWC	Remarks
P			△			△						PARK POSITION
R			○		○	○			☆		☆	REVERSE POSITION
N			△			△						NEUTRAL POSITION
D	1st		△*			△	△**	○	☆	☆	☆	Automatic shift 1⇔2⇔3⇔4⇔5
	2nd			○		△		○		☆	☆	
	3rd		○	○		○		△	★		☆	
	4th	○	○	○				△	★			
	5th	○	○			○		△	★		★	
M5	1st		△*			△	△**	○	☆	☆	☆	Automatic shift 1⇔2⇔3⇔4⇔5
	2nd			○		△		○		☆	☆	
	3rd		○	○		○		△	★		☆	
	4th	○	○	○				△	★			
	5th	○	○			○		△	★		★	
M4	1st		△*			△	△**	○	☆	☆	☆	Automatic shift 1⇔2⇔3⇔4
	2nd			○		△		○		☆	☆	
	3rd		○	○		○		△	★		☆	
	4th	○	○	○				△	★			
M3	1st		△*			△	△**	○	☆	☆	☆	Automatic shift 1⇔2⇔3
	2nd			○		△		○		☆	☆	
	3rd		○	○		○		△	★		☆	
M2	1st		△*			△	△**	○	☆	☆	☆	Automatic shift 1⇔2
	2nd			○		○	○	○		☆	☆	
M1	1st		○			○	○	○	☆	☆	☆	Locks (held stationary in 1st gear)
	2nd			○		○	○	○		☆	☆	

- ○—Operates
- ☆—Operates during “progressive” acceleration.
- ★—Operates and effects power transmission while coasting.
- △—Line pressure is applied but does not affect power transmission.
- △*—Operates under conditions shown in HLR/C Operating Condition
- △**—Operates under conditions shown in LC/B Operating Condition. Delay control is applied during D (4,3,2,1) ⇒N shift.

A/T CONTROL SYSTEM

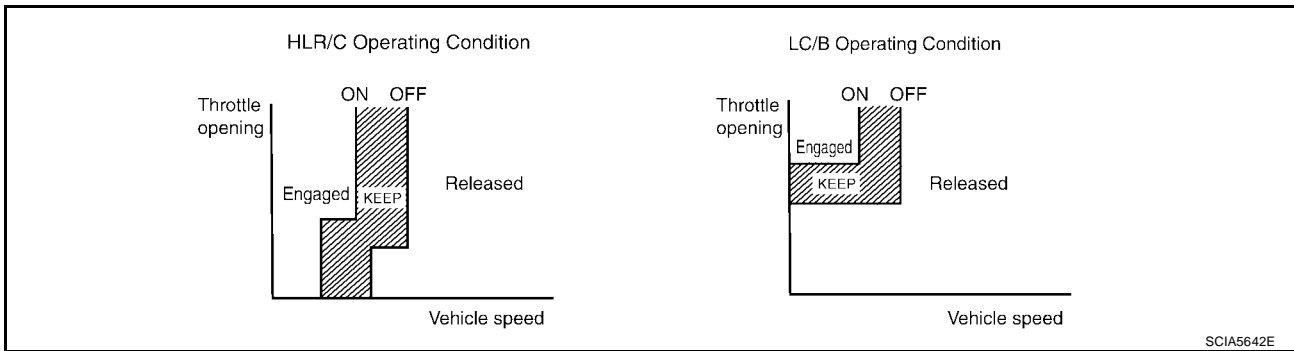

POWER TRANSMISSION

“N” position

Since both the forward brake and the reverse brake are released, torque from the input shaft drive is not transmitted to the output shaft.

“P” position

- The same as for the “N” position, both the forward brake and the reverse brake are released, so torque from the input shaft drive is not transmitted to the output shaft.
- The parking pawl linked with the select lever meshes with the parking gear and fastens the output shaft mechanically.

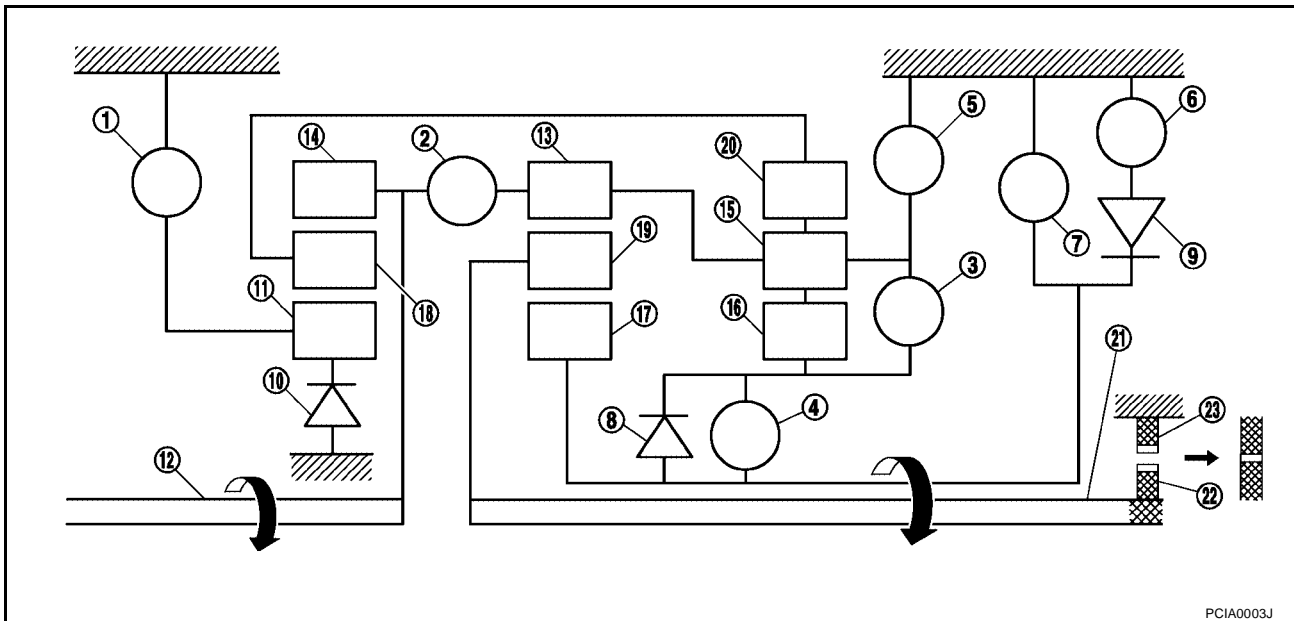

- | | | |
|--------------------------------|-------------------------|---------------------------|
| 1. Front brake | 2. Input clutch | 3. Direct clutch |
| 4. High and low reverse clutch | 5. Reverse brake | 6. Forward brake |
| 7. Low coast brake | 8. 1st one-way clutch | 9. Forward one-way clutch |
| 10. 3rd one-way clutch | 11. Front sun gear | 12. Input shaft |
| 13. Mid internal gear | 14. Front internal gear | 15. Rear carrier |
| 16. Rear sun gear | 17. Mid sun gear | 18. Front carrier |
| 19. Mid carrier | 20. Rear internal gear | 21. Output shaft |
| 22. Parking gear | 23. Parking pawl | |

A/T CONTROL SYSTEM

“D”, “M5”, “M4”, “M3”, “M2” positions (column shift), “D”, “4”, “3”, “2” positions (floor shift) 1st Gear

- The forward brake and the forward one-way clutch regulate reverse rotation of the mid sun gear.
- The 1st one-way clutch regulates reverse rotation of the rear sun gear.
- The 3rd one-way clutch regulates reverse rotation of the front sun gear.
- During deceleration, the mid sun gear turns forward, so the forward one-way clutch idles and the engine brake is not activated.

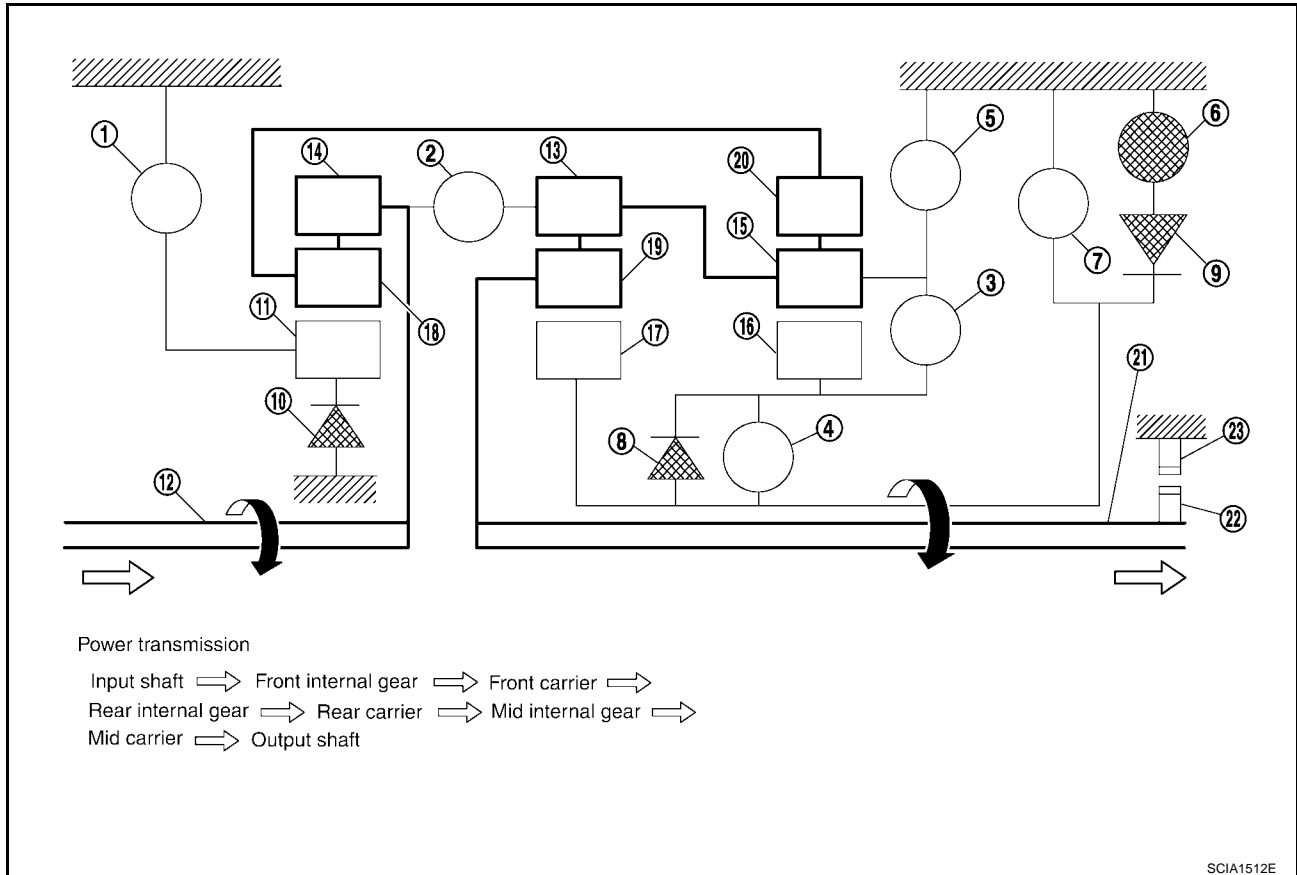

- | | | |
|--------------------------------|-------------------------|---------------------------|
| 1. Front brake | 2. Input clutch | 3. Direct clutch |
| 4. High and low reverse clutch | 5. Reverse brake | 6. Forward brake |
| 7. Low coast brake | 8. 1st one-way clutch | 9. Forward one-way clutch |
| 10. 3rd one-way clutch | 11. Front sun gear | 12. Input shaft |
| 13. Mid internal gear | 14. Front internal gear | 15. Rear carrier |
| 16. Rear sun gear | 17. Mid sun gear | 18. Front carrier |
| 19. Mid carrier | 20. Rear internal gear | 21. Output shaft |
| 22. Parking gear | 23. Parking pawl | |

A/T CONTROL SYSTEM

“M1” position (column shift), “1 ” position (floor shift) 1st Gear

- The front brake fastens the front sun gear.
- The forward brake and the forward one-way clutch regulate reverse rotation of the mid sun gear.
- High and low reverse clutch connects the rear sun gear and the mid sun gear.
- The low coast brake fastens the mid sun gear.
- During deceleration, the low coast brake regulates forward rotation of the mid sun gear and the engine brake functions.

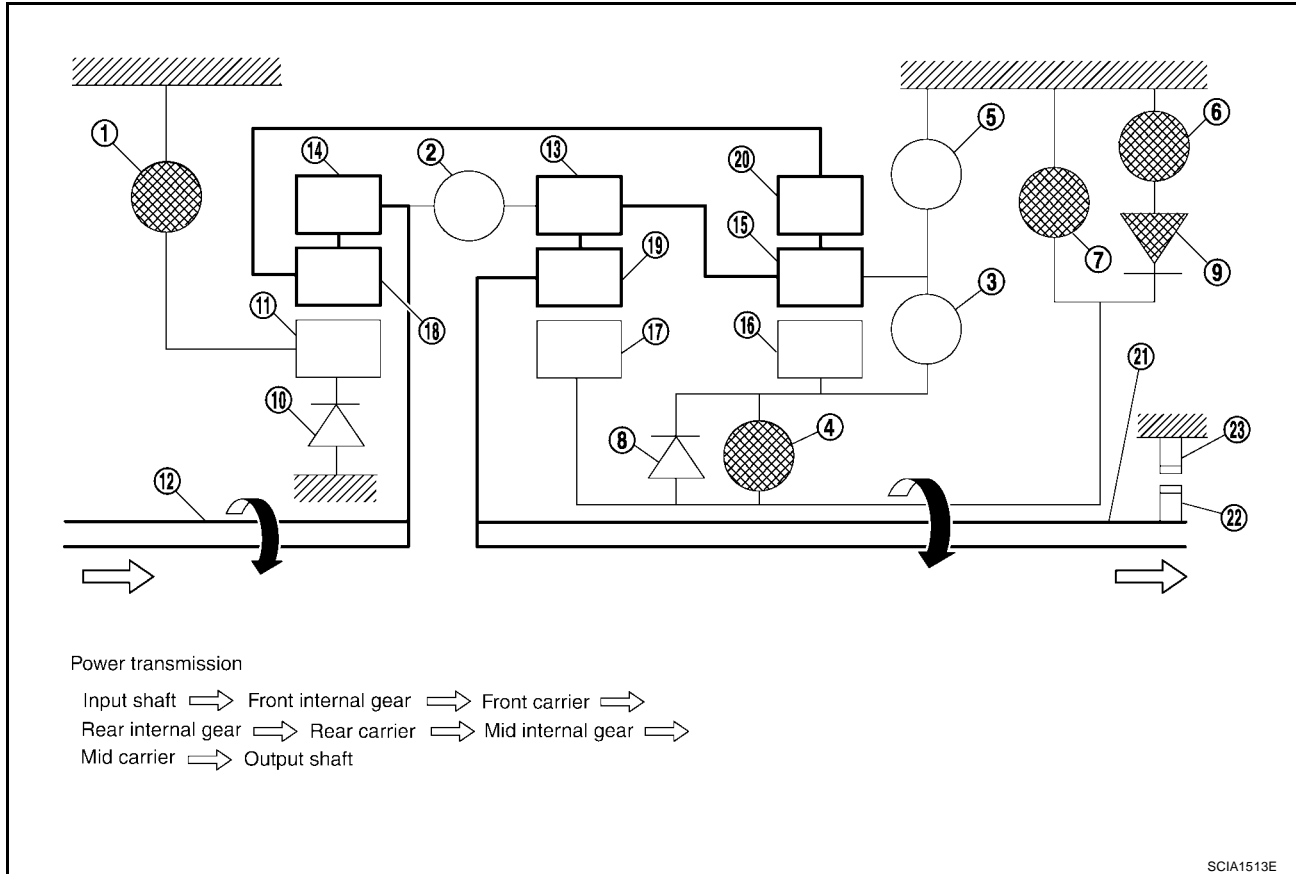

- | | | |
|--------------------------------|-------------------------|---------------------------|
| 1. Front brake | 2. Input clutch | 3. Direct clutch |
| 4. High and low reverse clutch | 5. Reverse brake | 6. Forward brake |
| 7. Low coast brake | 8. 1st one-way clutch | 9. Forward one-way clutch |
| 10. 3rd one-way clutch | 11. Front sun gear | 12. Input shaft |
| 13. Mid internal gear | 14. Front internal gear | 15. Rear carrier |
| 16. Rear sun gear | 17. Mid sun gear | 18. Front carrier |
| 19. Mid carrier | Rear internal gear | 21. Output shaft |
| 20. | 20. | |
| 22. Parking gear | 23. Parking pawl | |

A/T CONTROL SYSTEM

“D”, “M5”, “M4”, “M3” positions (column shift), “D”, “4”, “3” positions (floor shift) 2nd Gear

- The forward brake and the forward one-way clutch regulate reverse rotation of the mid sun gear.
- The 3rd one-way clutch regulates reverse rotation of the front sun gear.
- The direct clutch is coupled and the rear carrier and rear sun gear are connected.
- During deceleration, the mid sun gear turns forward, so the forward one-way clutch idles and engine brake is not activated.

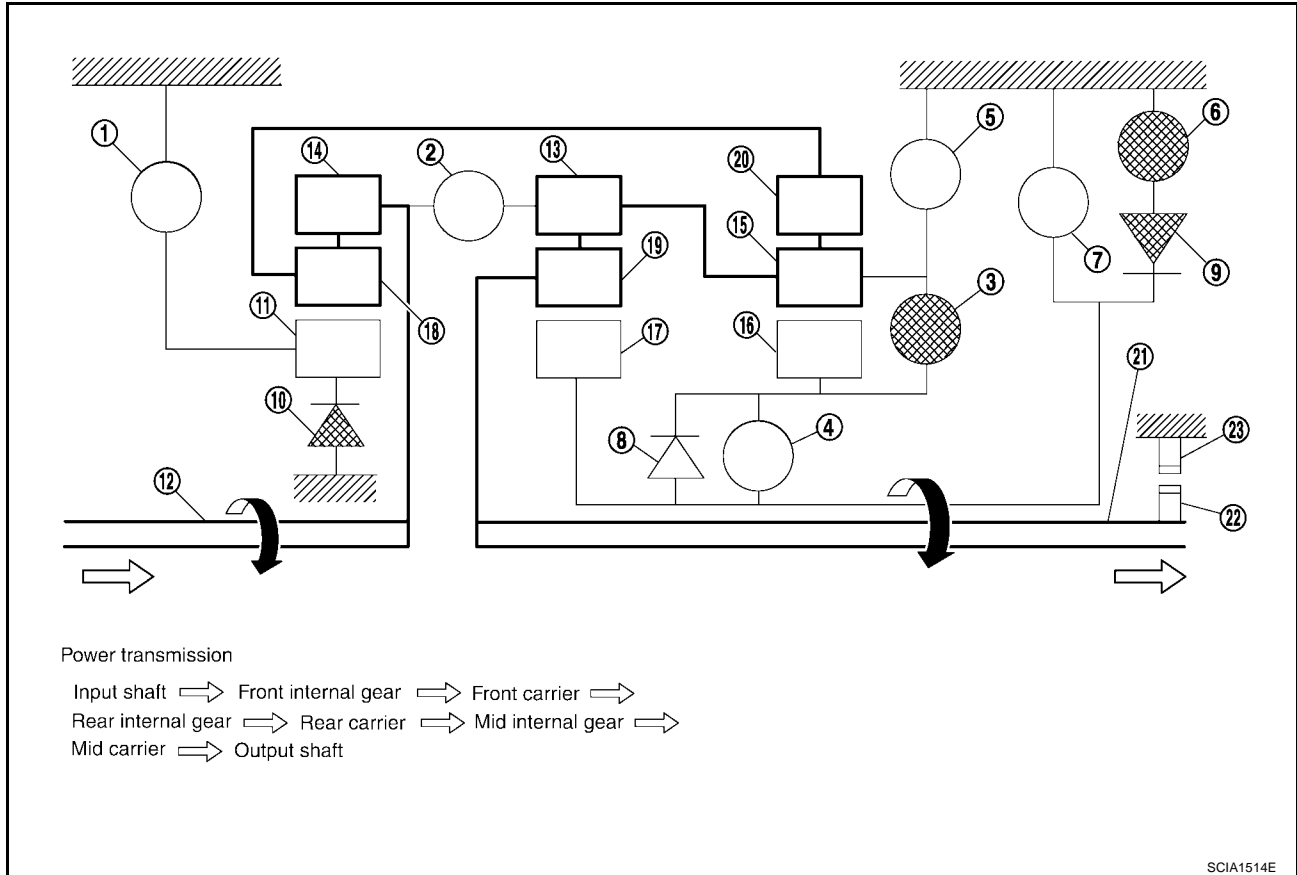

- | | | |
|--------------------------------|-------------------------|---------------------------|
| 1. Front brake | 2. Input clutch | 3. Direct clutch |
| 4. High and low reverse clutch | 5. Reverse brake | 6. Forward brake |
| 7. Low coast brake | 8. 1st one-way clutch | 9. Forward one-way clutch |
| 10. 3rd one-way clutch | 11. Front sun gear | 12. Input shaft |
| 13. Mid internal gear | 14. Front internal gear | 15. Rear carrier |
| 16. Rear sun gear | 17. Mid sun gear | 18. Front carrier |
| 19. Mid carrier | 20. Rear internal gear | 21. Output shaft |
| 22. Parking gear | 23. Parking pawl | |

A/T CONTROL SYSTEM

“M2”, “M1” positions (column shift), “2”, “1” positions (floor shift) 2nd Gear

- The front brake fastens the front sun gear.
- The forward brake and the forward one-way clutch regulate reverse rotation of the mid sun gear.
- The direct clutch is coupled, and the rear carrier and rear sun gear are connected.
- The low coast brake fastens the mid sun gear.
- During deceleration, the low coast brake regulates forward rotation of the mid sun gear and the engine brake functions.

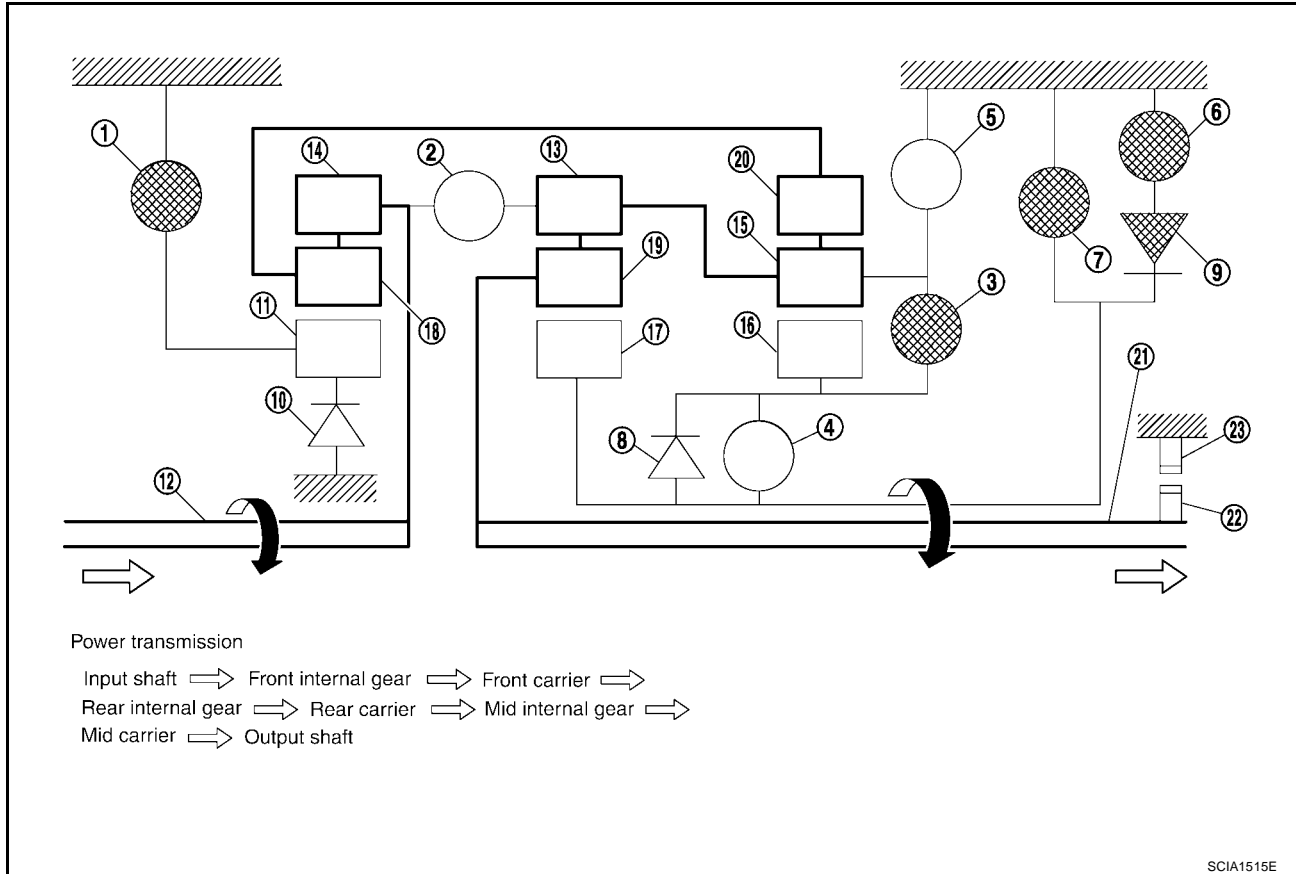

- | | | |
|--------------------------------|-------------------------|---------------------------|
| 1. Front brake | 2. Input clutch | 3. Direct clutch |
| 4. High and low reverse clutch | 5. Reverse brake | 6. Forward brake |
| 7. Low coast brake | 8. 1st one-way clutch | 9. Forward one-way clutch |
| 10. 3rd one-way clutch | 11. Front sun gear | 12. Input shaft |
| 13. Mid internal gear | 14. Front internal gear | 15. Rear carrier |
| 16. Rear sun gear | 17. Mid sun gear | 18. Front carrier |
| 19. Mid carrier | 20. Rear internal gear | 21. Output shaft |
| 22. Parking gear | 23. Parking pawl | |

A/T CONTROL SYSTEM

“D”, “M5”, “M4”, “M3” positions (column shift), “D”, “4”, “3” positions (floor shift) 3rd Gear

- The front brake fastens the front sun gear.
- The direct clutch is coupled, and the rear carrier and rear sun gear are connected.
- The high and low reverse clutch is coupled and the mid sun gear and rear sun gear are connected.

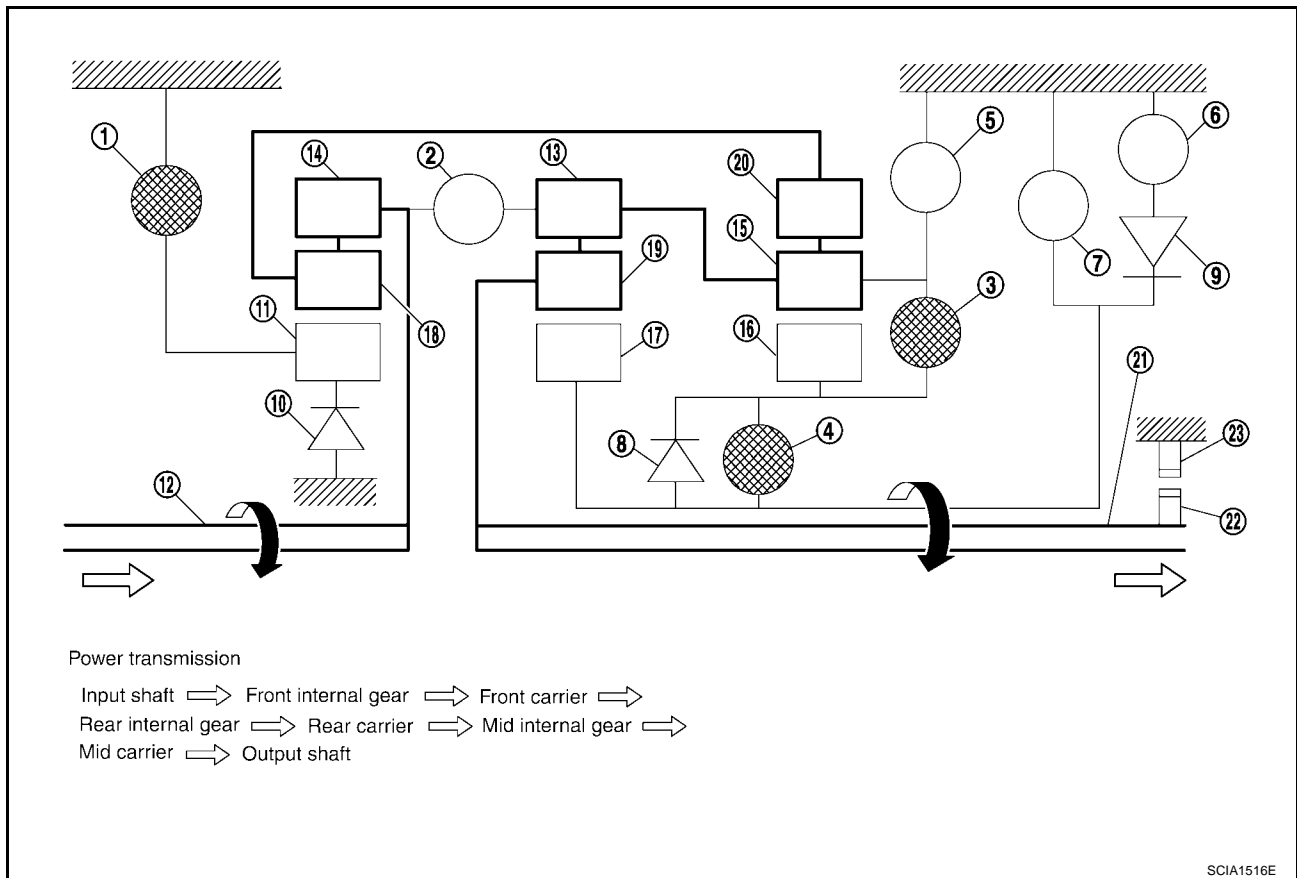

- | | | |
|--------------------------------|-------------------------|---------------------------|
| 1. Front brake | 2. Input clutch | 3. Direct clutch |
| 4. High and low reverse clutch | 5. Reverse brake | 6. Forward brake |
| 7. Low coast brake | 8. 1st one-way clutch | 9. Forward one-way clutch |
| 10. 3rd one-way clutch | 11. Front sun gear | 12. Input shaft |
| 13. Mid internal gear | 14. Front internal gear | 15. Rear carrier |
| 16. Rear sun gear | 17. Mid sun gear | 18. Front carrier |
| 19. Mid carrier | 20. Rear internal gear | 21. Output shaft |
| 22. Parking gear | 23. Parking pawl | |

A/T CONTROL SYSTEM

“D”, “M5”, “M4” positions (column shift), “D”, “4” positions (floor shift) 4th Gear

- The direct clutch is coupled, and the rear carrier and rear sun gear are connected.
- The high and low reverse clutch is coupled and the mid sun gear and rear sun gear are connected.
- The input clutch is coupled and the front internal gear and mid internal gear are connected.
- The drive power is conveyed to the front internal gear, mid internal gear, and rear carrier and the three planetary gears rotate forward as one unit.

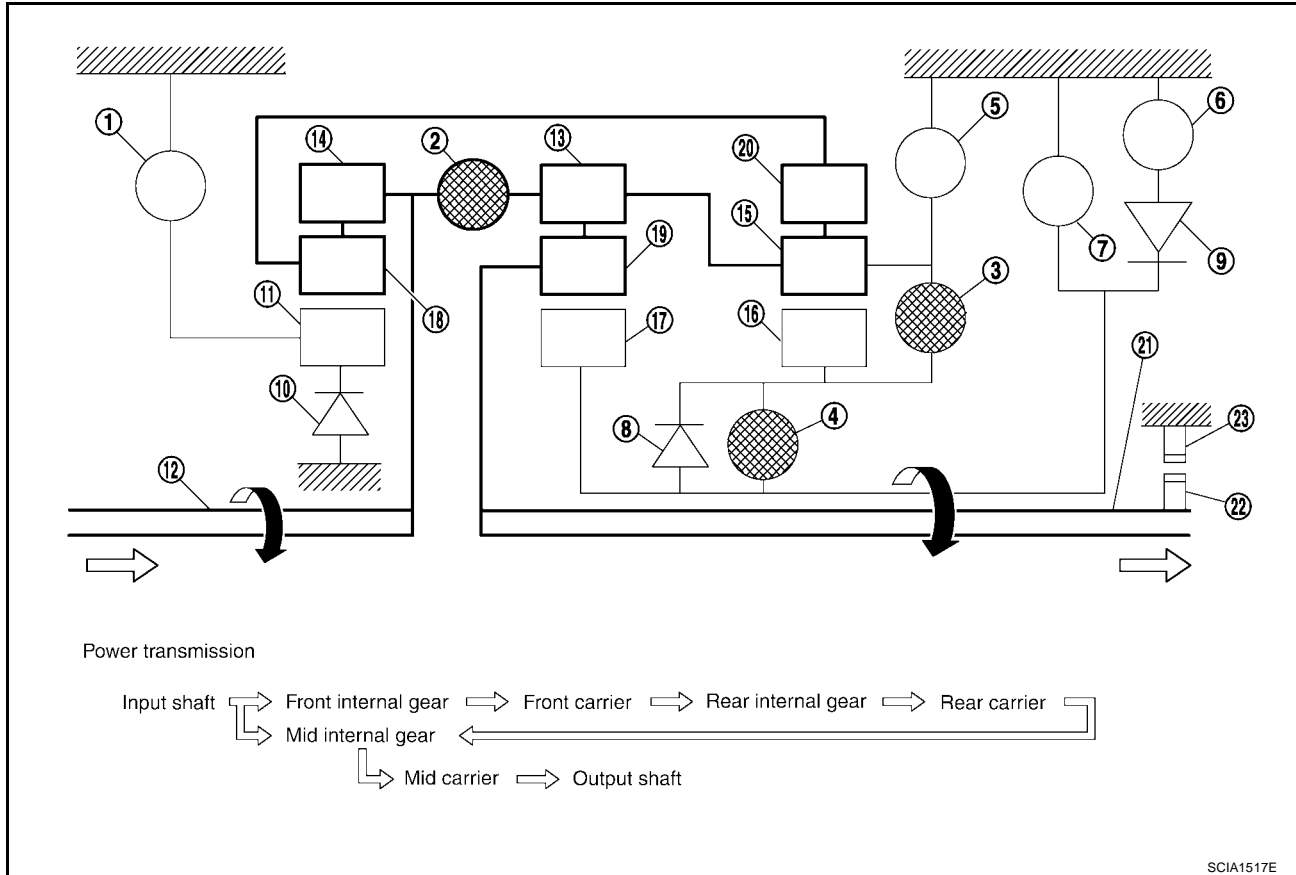

- | | | |
|--------------------------------|-------------------------|---------------------------|
| 1. Front brake | 2. Input clutch | 3. Direct clutch |
| 4. High and low reverse clutch | 5. Reverse brake | 6. Forward brake |
| 7. Low coast brake | 8. 1st one-way clutch | 9. Forward one-way clutch |
| 10. 3rd one-way clutch | 11. Front sun gear | 12. Input shaft |
| 13. Mid internal gear | 14. Front internal gear | 15. Rear carrier |
| 16. Rear sun gear | 17. Mid sun gear | 18. Front carrier |
| 19. Mid carrier | 20. Rear internal gear | 21. Output shaft |
| 22. Parking gear | 23. Parking pawl | |

SCIA1517E

A/T CONTROL SYSTEM

“D”, “M5” positions (column shift), “D” position (floor shift) 5th Gear

- The front brake fastens the front sun gear.
- The input clutch is coupled and the front internal gear and mid internal gear are connected.
- The high and low reverse clutch is coupled and the mid sun gear and rear sun gear are connected.

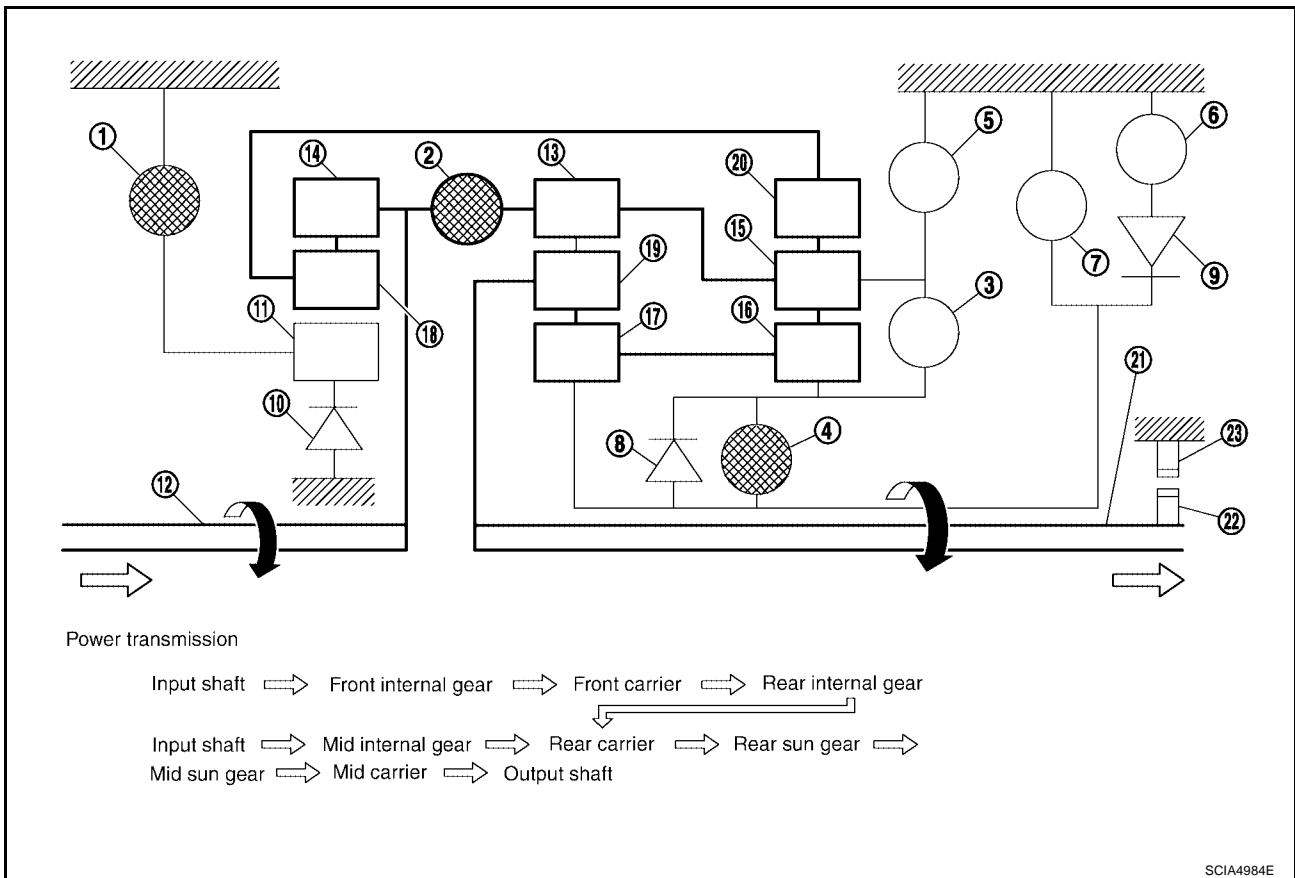

- | | | |
|--------------------------------|-------------------------|---------------------------|
| 1. Front brake | 2. Input clutch | 3. Direct clutch |
| 4. High and low reverse clutch | 5. Reverse brake | 6. Forward brake |
| 7. Low coast brake | 8. 1st one-way clutch | 9. Forward one-way clutch |
| 10. 3rd one-way clutch | 11. Front sun gear | 12. Input shaft |
| 13. Mid internal gear | 14. Front internal gear | 15. Rear carrier |
| 16. Rear sun gear | 17. Mid sun gear | 18. Front carrier |
| 19. Mid carrier | 20. Rear internal gear | 21. Output shaft |
| 22. Parking gear | 23. Parking pawl | |

A/T CONTROL SYSTEM

"R" position

- The front brake fastens the front sun gear.
- The high and low reverse clutch is coupled, and the mid sun gear and rear sun gear are connected.
- The reverse brake fastens the rear carrier.

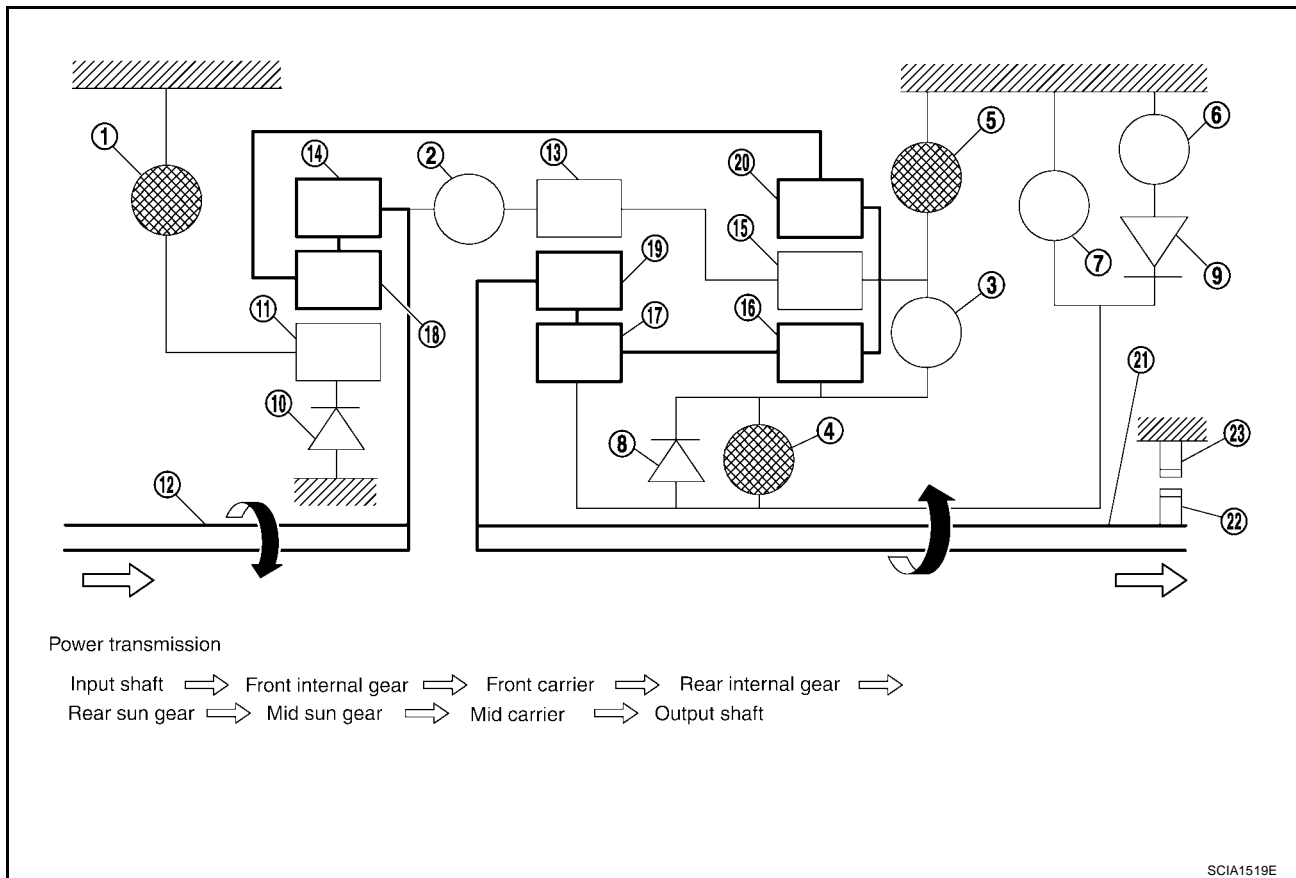

- | | | |
|--------------------------------|-------------------------|---------------------------|
| 1. Front brake | 2. Input clutch | 3. Direct clutch |
| 4. High and low reverse clutch | 5. Reverse brake | 6. Forward brake |
| 7. Low coast brake | 8. 1st one-way clutch | 9. Forward one-way clutch |
| 10. 3rd one-way clutch | 11. Front sun gear | 12. Input shaft |
| 13. Mid internal gear | 14. Front internal gear | 15. Rear carrier |
| 16. Rear sun gear | 17. Mid sun gear | 18. Front carrier |
| 19. Mid carrier | 20. Rear internal gear | 21. Output shaft |
| 22. Parking gear | 23. Parking pawl | |

A/T CONTROL SYSTEM

ECS00AW3

TCM Function

The function of the TCM is to:

- Receive input signals sent from various switches and sensors.
- Determine required line pressure, shifting point, lock-up operation, and engine brake operation.
- Send required output signals to the respective solenoids.

CONTROL SYSTEM OUTLINE (FLOOR SHIFT)

The automatic transmission senses vehicle operating conditions through various sensors or signals. It always controls the optimum shift position and reduces shifting and lock-up shocks.

SENSORS (or SIGNALS)		TCM		ACTUATORS
PNP switch Accelerator pedal position sensor Closed throttle position signal Wide open throttle position signal Engine speed signal A/T fluid temperature sensor Revolution sensor Vehicle speed signal Stop lamp switch signal Turbine revolution sensor 1st position switch signal 4th position switch signal ATF pressure switch Tow mode switch signal	⇒	Shift control Line pressure control Lock-up control Engine brake control Timing control Fail-safe control Self-diagnosis CONSULT-II communication line Duet-EA control CAN system	⇒	Input clutch solenoid valve Direct clutch solenoid valve Front brake solenoid valve High and low reverse clutch solenoid valve Low coast brake solenoid valve Torque converter clutch solenoid valve Line pressure solenoid valve A/T CHECK indicator lamp Starter relay Back-up lamp relay

CONTROL SYSTEM DIAGRAM

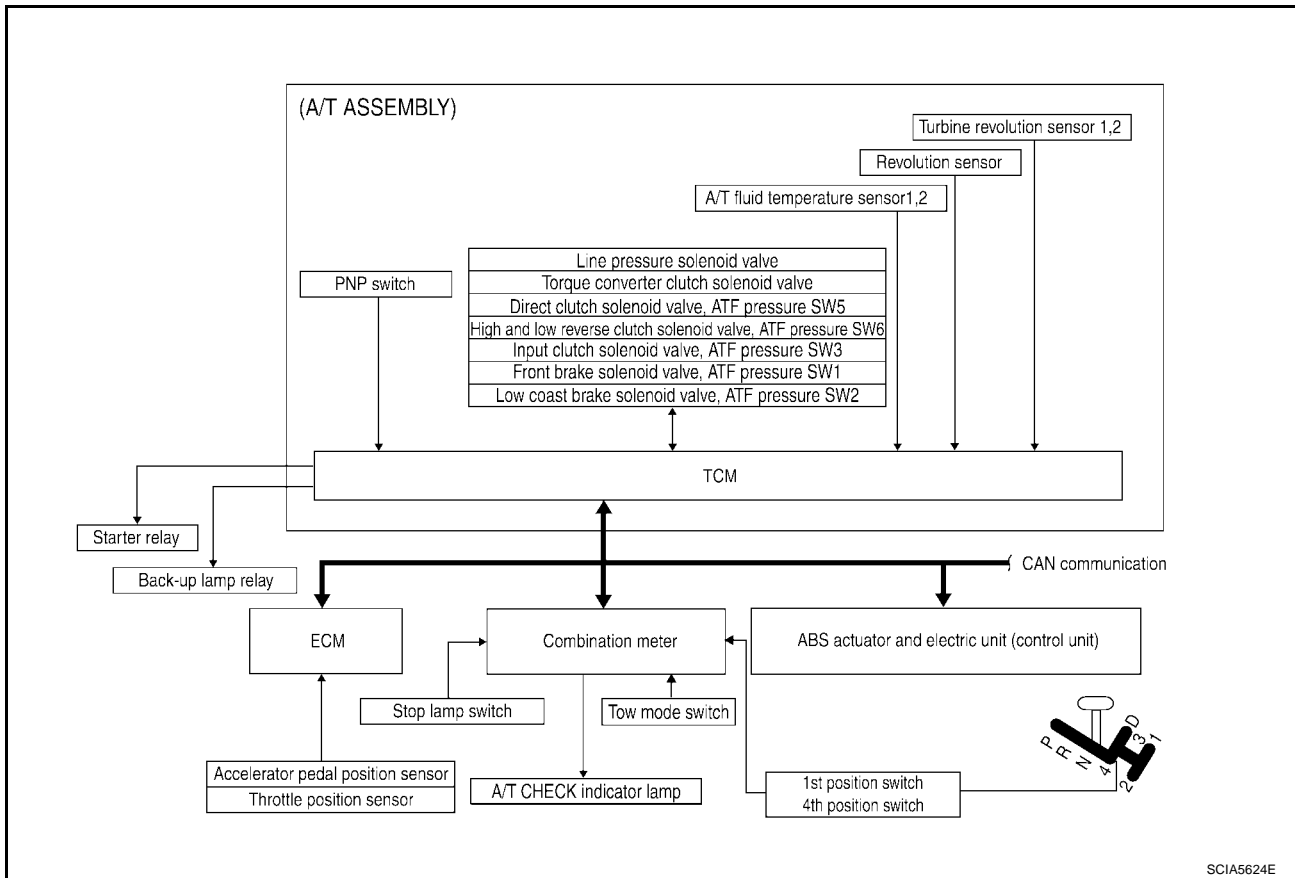

SCIA5624E

A/T CONTROL SYSTEM

CONTROL SYSTEM OUTLINE (COLUMN SHIFT)

The automatic transmission senses vehicle operating conditions through various sensors or signals. It always controls the optimum shift position and reduces shifting and lock-up shocks.

SENSORS (or SIGNALS)		TCM		ACTUATORS
PNP switch Accelerator pedal position sensor Closed throttle position signal Wide open throttle position signal Engine speed signal A/T fluid temperature sensor Revolution sensor Vehicle speed signal Stop lamp switch signal Turbine revolution sensor Manual mode switch Tow mode switch signal	⇒	Shift control Line pressure control Lock-up control Engine brake control Timing control Fail-safe control Self-diagnosis CONSULT-II communication line Duet-EA control CAN system	⇒	Input clutch solenoid valve Direct clutch solenoid valve Front brake solenoid valve High and low reverse clutch solenoid valve Low coast brake solenoid valve Torque converter clutch solenoid valve Line pressure solenoid valve A/T CHECK indicator lamp Starter relay Back-up lamp relay

CONTROL SYSTEM DIAGRAM

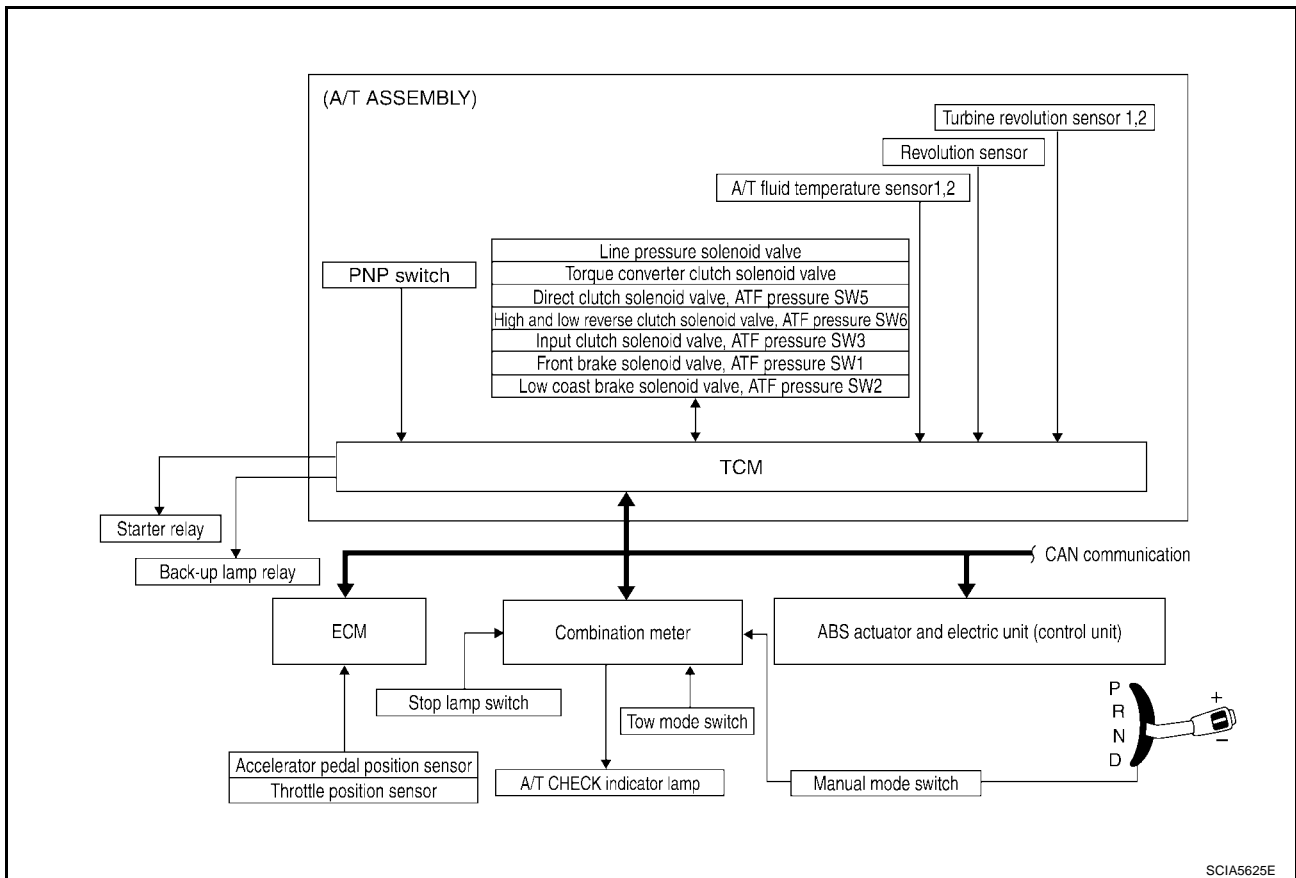

A/T CONTROL SYSTEM

CAN Communication SYSTEM DESCRIPTION

ECS00AW4

CAN (Controller Area Network) is a serial communication line for real time application. It is an on-vehicle multiplex communication line with high data communication speed and excellent error detection ability. Many electronic control units are equipped onto a vehicle, and each control unit shares information and links with other control units during operation (not independent). In CAN communication, control units are connected with 2 communication lines (CAN H line, CAN L line) allowing a high rate of information transmission with less wiring. Each control unit transmits/receives data but selectively reads required data only. For details, refer to [LAN-7, "CAN COMMUNICATION"](#).

Input/Output Signal of TCM

ECS00AW5

Control item		Line pressure control	Vehicle speed control	Shift control	Lock-up control	Engine brake control	Fail-safe function (*3)	Self-diagnosis function	
Input	Accelerator pedal position signal (*4)	X	X	X	X	X	X	X	
	Vehicle speed sensor A/T (revolution sensor)	X	X	X	X		X	X	
	Vehicle speed sensor MTR ^(*1) (*4)	X	X	X	X			X	
	Closed throttle position signal(*4)	(*2) X	(*2) X		X	(*2) X		X	
	Wide open throttle position signal(*4)	(*2) X	(*2) X			(*2) X		X	
	Turbine revolution sensor 1	X	X		X		X	X	
	Turbine revolution sensor 2 (for 4th speed only)	X	X		X		X	X	
	Engine speed signals(*4)				X			X	
	PNP switch	X	X	X	X	X	X	X	
	A/T fluid temperature sensors 1, 2	X	X	X	X	X	X	X	
	ASCD	Operation signal(*4)		X	X	X	X		
		Overdrive cancel signal(*4)		X		X	X		
		TCM power supply voltage signal	X	X	X	X	X		X
Output	Direct clutch solenoid (ATF pressure switch 5)		X	X			X	X	
	Input clutch solenoid (ATF pressure switch 3)		X	X			X	X	
	High & low reverse clutch solenoid (ATF pressure switch 6)		X	X			X	X	
	Front brake solenoid (ATF pressure switch 1)		X	X			X	X	
	Low coast brake solenoid (ATF pressure switch 2)		X	X		X	X	X	
	Line pressure solenoid	X	X	X	X	X	X	X	
	TCC solenoid				X		X	X	
	Self-diagnosis table(*4)							X	
	Starter relay						X	X	

*1: Spare for vehicle speed sensor-A/T (revolution sensor)

*2: Spare for accelerator pedal position signal

*3: If these input and output signals are different, the TCM triggers the fail-safe function.

*4: CAN communications

Line Pressure Control

- When an input torque signal equivalent to the engine drive force is sent from the ECM to the TCM, the TCM controls the line pressure solenoid.
- This line pressure solenoid controls the pressure regulator valve as the signal pressure and adjusts the pressure of the operating oil discharged from the oil pump to the line pressure most appropriate to the driving state.

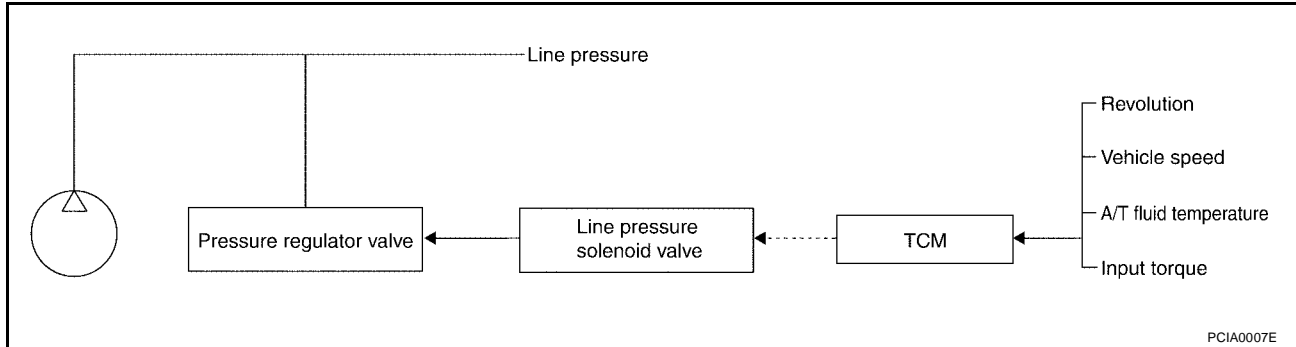

LINE PRESSURE CONTROL IS BASED ON THE TCM LINE PRESSURE CHARACTERISTIC PATTERN

- The TCM has stored in memory a number of patterns for the optimum line pressure characteristic for the driving state.
- In order to obtain the most appropriate line pressure characteristic to meet the current driving state, the TCM controls the line pressure solenoid current valve and thus controls the line pressure.

Normal control

Each clutch is adjusted to the necessary pressure to match the engine drive force.

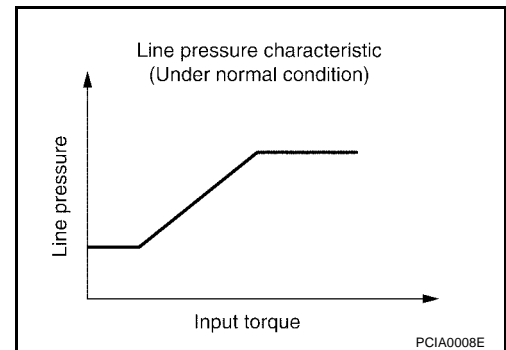

Back-up control (Engine brake)

When the select operation is performed during driving and the transmission is shifted down, the line pressure is set according to the vehicle speed.

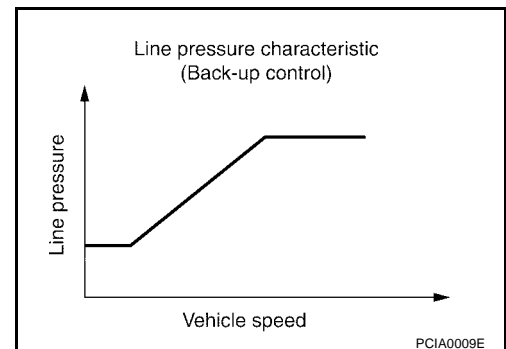

A/T CONTROL SYSTEM

During shift change

The necessary and adequate line pressure for shift change is set. For this reason, line pressure pattern setting corresponds to input torque and gearshift selection. Also, line pressure characteristic is set according to engine speed, during engine brake operation.

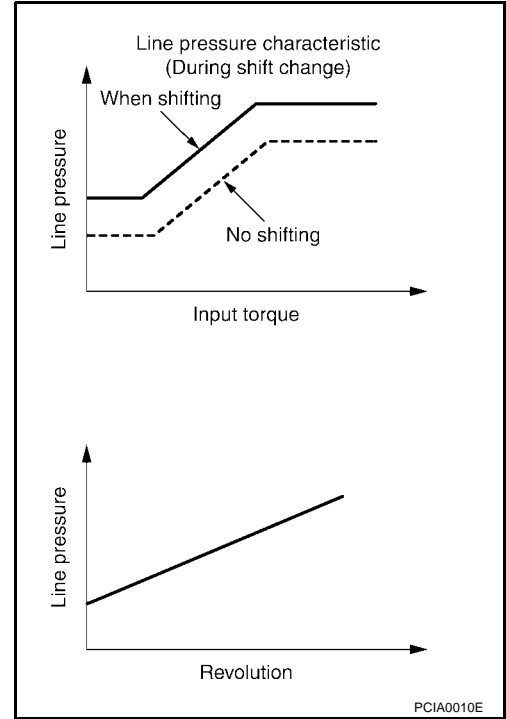

At low fluid temperature

When the A/T fluid temperature drops below the prescribed temperature, in order to speed up the action of each friction element, the line pressure is set higher than the normal line pressure characteristic.

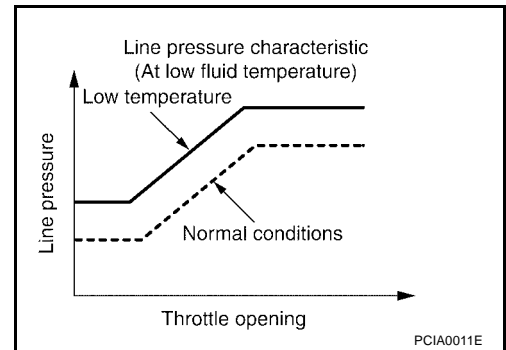

Shift Control

The clutch pressure control solenoid is controlled by the signals from the switches and sensors. Thus, the clutch pressure is adjusted to be appropriate to the engine load state and vehicle driving state. It becomes possible to finely control the clutch hydraulic pressure with high precision and a smoother shift change characteristic is attained.

ECS00AW7

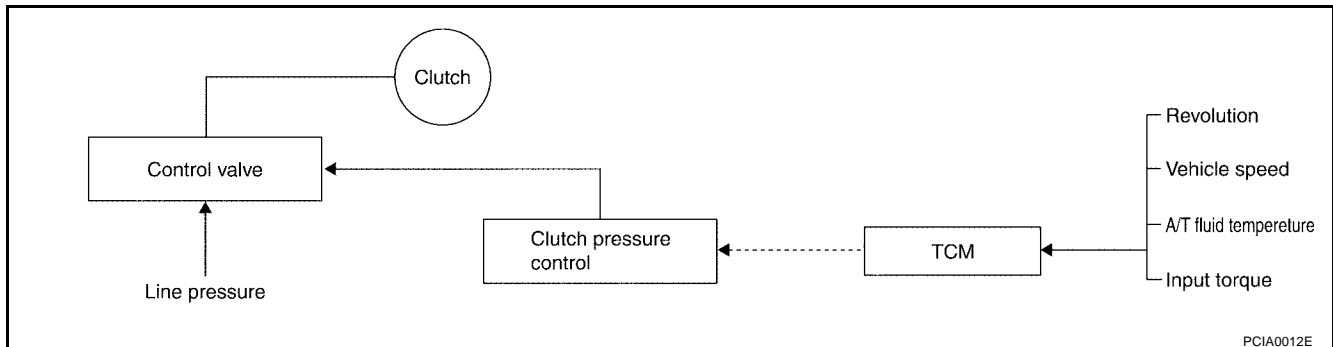

SHIFT CHANGE

The clutch is controlled with the optimum timing and oil pressure by the engine speed, engine torque information, etc.

A/T CONTROL SYSTEM

Shift change system diagram

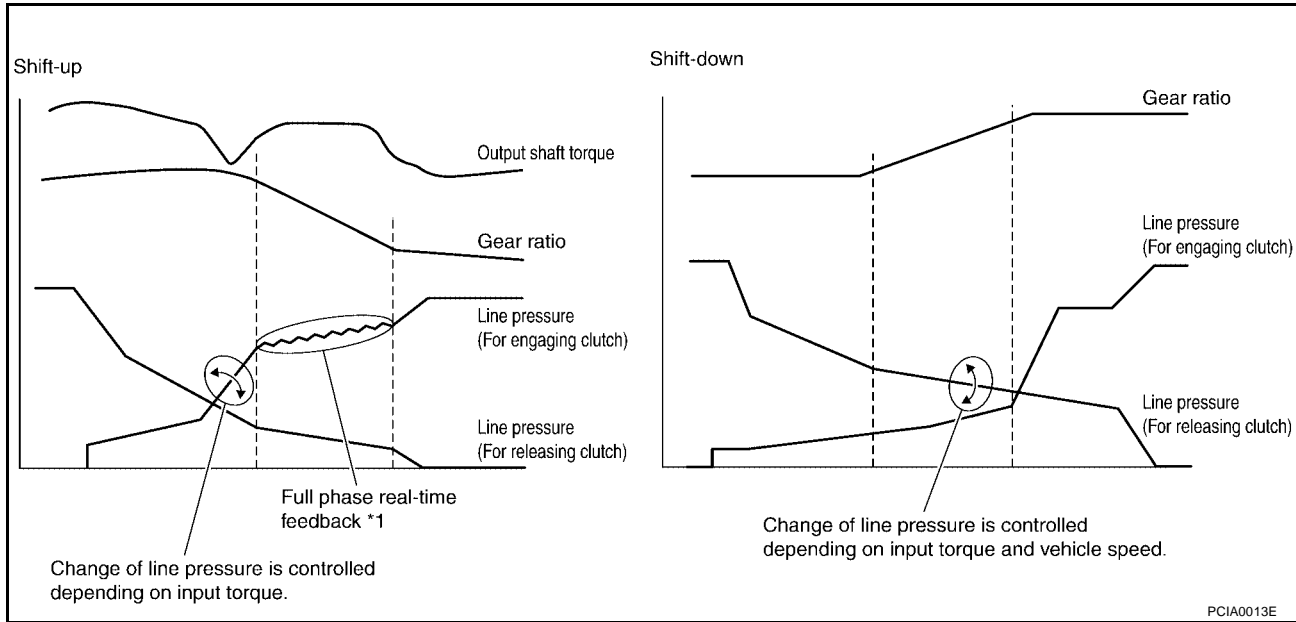

*1: Full phase real-time feedback control monitors movement of gear ratio at gear change, and controls oil pressure at real-time to achieve the best gear ratio.

Lock-Up Control

ECS00AW8

The torque converter clutch piston in the torque converter is engaged to eliminate torque converter slip to increase power transmission efficiency.

The torque converter clutch control valve operation is controlled by the torque converter clutch solenoid valve, which is controlled by a signal from TCM, and the torque converter clutch control valve engages or releases the torque converter clutch piston.

Lock-up Operation Condition Table

Select lever	D position		M5 position	M4 or 4 position	M3 or 3 position	M2 or 2 position
Gear position	5	4	5	4	3	2
Lock-up	×	—	×	×	×	×
Slip lock-up	×	×	—	—	—	—

TORQUE CONVERTER CLUTCH CONTROL VALVE CONTROL

Lock-up control system diagram

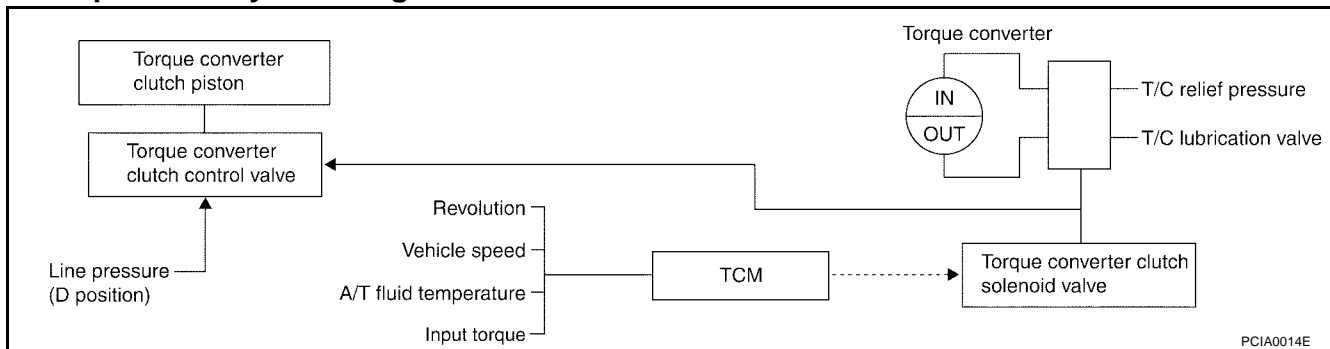

Lock-up released

- In the lock-up released state, the torque converter clutch control valve is set into the unlocked state by the torque converter clutch solenoid and the lock-up apply pressure is drained. In this way, the torque converter clutch piston is not coupled.

A/T CONTROL SYSTEM

Lock-up applied

- In the lock-up applied state, the torque converter clutch control valve is set into the locked state by the torque converter clutch solenoid and lock-up apply pressure is generated.
In this way, the torque converter clutch piston is pressed and coupled.

SMOOTH LOCK-UP CONTROL

When shifting from the lock-up released state to the lock-up applied state, the current output to the torque converter clutch solenoid is controlled with the TCM. In this way, when shifting to the lock-up applied state, the torque converter clutch is temporarily set to the half-clutched state to reduce the shock.

Half-clutched state

- The current output from the TCM to the torque converter clutch solenoid is varied to gradually increase the torque converter clutch solenoid pressure.
In this way, the lock-up apply pressure gradually rises and while the torque converter clutch piston is put into half-clutched status, the torque converter clutch piston operating pressure is increased and the coupling is completed smoothly.

Slip lock-up control

- In the slip region, the torque converter clutch solenoid current is controlled with the TCM to put it into the half-clutched state. This absorbs the engine torque fluctuation and lock-up operates from low speed. This raises the fuel efficiency for 4th and 5th gears at both low speed and when the accelerator has a low degree of opening.

A/T CONTROL SYSTEM

ECS00AW9

Engine Brake Control

- The forward one-way clutch transmits the drive force from the engine to the rear wheels. But the reverse drive from the rear wheels is not transmitted to the engine because the one-way clutch is idling. Therefore, the low coast brake solenoid is operated to prevent the forward one-way clutch from idling and the engine brake is operated in the same manner as conventionally.

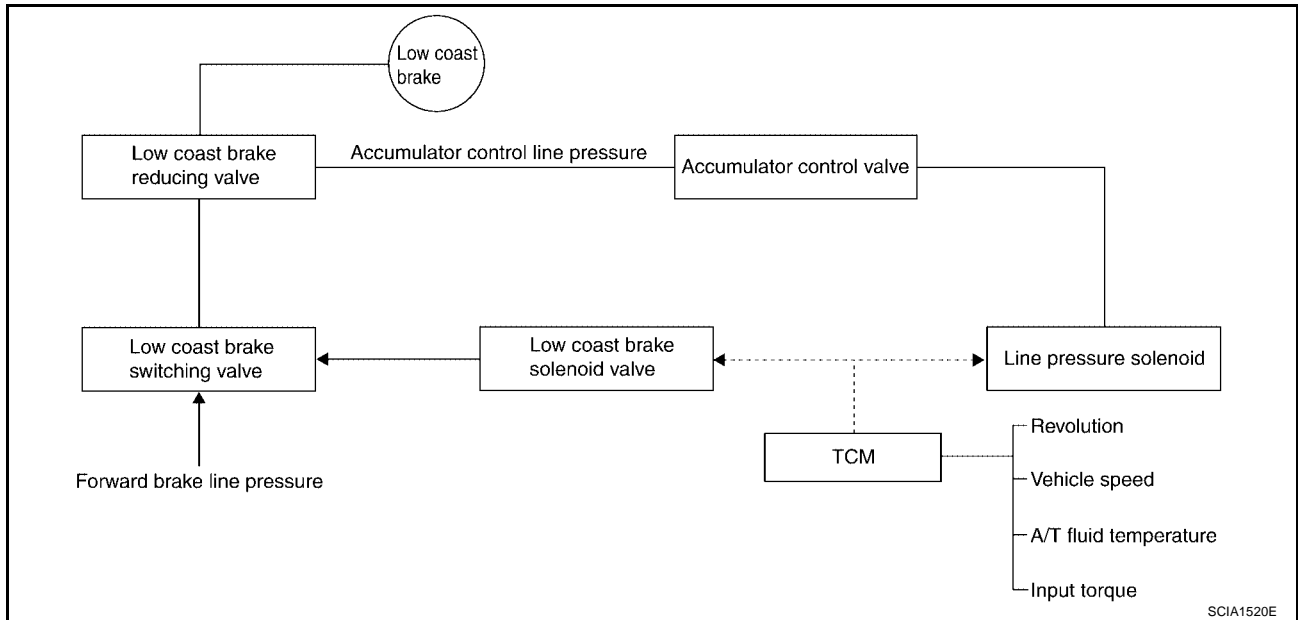

- The operation of the low coast brake solenoid switches the low coast brake switching valve and controls the coupling and releasing of the low coast brake. The low coast brake reducing valve controls the low coast brake coupling force.

Control Valve

ECS00AWA

FUNCTION OF CONTROL VALVE

Name	Function
Torque converter regulator valve	In order to prevent the pressure supplied to the torque converter from being excessive, the line pressure is adjusted to the optimum pressure (torque converter operating pressure).
Pressure regulator valve Pressure regulator plug Pressure regulator sleeve	Adjusts the oil discharged from the oil pump to the optimum pressure (line pressure) for the driving state.
Front brake control valve	When the front brake is coupled, adjusts the line pressure to the optimum pressure (front brake pressure) and supplies it to the front brake. (In 1st, 2nd, 3rd, and 5th gears, adjusts the clutch pressure.)
Accumulator control valve	Adjusts the pressure (accumulator control pressure) acting on the accumulator piston and low coast reducing valve to the pressure appropriate to the driving state.
Pilot valve A	Adjusts the line pressure and produces the constant pressure (pilot pressure) required for line pressure control, shift change control, and lock-up control.
Pilot valve B	Adjusts the line pressure and produces the constant pressure (pilot pressure) required for shift change control.
Low coast brake switching valve	During engine braking, supplies the line pressure to the low coast brake reducing valve.
Low coast brake reducing valve	When the low coast brake is coupled, adjusts the line pressure to the optimum pressure (low coast brake pressure) and supplies it to the low coast brake.
N-R accumulator	Produces the stabilizing pressure for when N-R is selected.
Direct clutch piston switching valve	Operates in 4th gear and switches the direct clutch coupling capacity.
High and low reverse clutch control valve	When the high and low reverse clutch is coupled, adjusts the line pressure to the optimum pressure (high and low reverse clutch pressure) and supplies it to the high and low reverse clutch. (In 1st, 3rd, 4th and 5th gears, adjusts the clutch pressure.)

A/T CONTROL SYSTEM

Name	Function
Input clutch control valve	When the input clutch is coupled, adjusts the line pressure to the optimum pressure (input clutch pressure) and supplies it to the input clutch. (In 4th and 5th gears, adjusts the clutch pressure.)
Direct clutch control valve	When the direct clutch is coupled, adjusts the line pressure to the optimum pressure (direct clutch pressure) and supplies it to the direct clutch. (In 2nd, 3rd, and 4th gears, adjusts the clutch pressure.)
TCC control valve TCC control plug TCC control sleeve	Switches the lock-up to operating or released. Also, by performing the lock-up operation transiently, lock-up smoothly.
Torque converter lubrication valve	Operates during lock-up to switch the torque converter, cooling, and lubrication system oil path.
Cool bypass valve	Allows excess oil to bypass cooler circuit without being fed into it.
Line pressure relief valve	Discharges excess oil from line pressure circuit.
N-D accumulator	Produces the stabilizing pressure for when N-D is selected.
Manual valve	Sends line pressure to each circuit according to the select position. The circuits to which the line pressure is not sent drain.

FUNCTION OF PRESSURE SWITCH

Name	Function
Pressure switch 1 (FR/B)	Detects any malfunction in the front brake hydraulic pressure. When it detects any malfunction, it puts the system into fail-safe mode.
Pressure switch 2 (LC/B)	Detects any malfunction in the low coast brake hydraulic pressure. When it detects any malfunction, it puts the system into fail-safe mode.
Pressure switch 3 (I/C)	Detects any malfunction in the input clutch hydraulic pressure. When it detects any malfunction, it puts the system into fail-safe mode.
Pressure switch 5 (D/C)	Detects any malfunction in the direct clutch hydraulic pressure. When it detects any malfunction, it puts the system into fail-safe mode.
Pressure switch 6 (HLR/C)	Detects any malfunction in the high and low reverse clutch hydraulic pressure. When it detects any malfunction, it puts the system into fail-safe mode.

ON BOARD DIAGNOSTIC (OBD) SYSTEM

PFP:00028

Introduction

ECS00AWB

The A/T system has two self-diagnostic systems.

The first is the emission-related on board diagnostic system (OBD-II) performed by the TCM in combination with the ECM. The malfunction is indicated by the MIL (malfunction indicator lamp) and is stored as a DTC in the ECM memory but not the TCM memory.

The second is the TCM original self-diagnosis indicated by the A/T CHECK indicator lamp. The malfunction is stored in the TCM memory. The detected items are overlapped with OBD-II self-diagnostic items. For detail, refer to [AT-87, "SELF-DIAGNOSTIC RESULT MODE"](#).

OBD-II Function for A/T System

ECS00AWC

The ECM provides emission-related on board diagnostic (OBD-II) functions for the A/T system. One function is to receive a signal from the TCM used with OBD-related parts of the A/T system. The signal is sent to the ECM when a malfunction occurs in the corresponding OBD-related part. The other function is to indicate a diagnostic result by means of the MIL (malfunction indicator lamp) on the instrument panel. Sensors, switches and solenoid valves are used as sensing elements.

The MIL automatically illuminates in One or Two Trip Detection Logic when a malfunction is sensed in relation to A/T system parts.

One or Two Trip Detection Logic of OBD-II

ECS00AWD

ONE TRIP DETECTION LOGIC

If a malfunction is sensed during the first test drive, the MIL will illuminate and the malfunction will be stored in the ECM memory as a DTC. The TCM is not provided with such a memory function.

TWO TRIP DETECTION LOGIC

When a malfunction is sensed during the first test drive, it is stored in the ECM memory as a 1st trip DTC (diagnostic trouble code) or 1st trip freeze frame data. At this point, the MIL will not illuminate. — 1st Trip

If the same malfunction as that experienced during the first test drive is sensed during the second test drive, the MIL will illuminate. — 2nd Trip



The "Trip" in the "One or Two Trip Detection Logic" means a driving mode in which self-diagnosis is performed during vehicle operation.

OBD-II Diagnostic Trouble Code (DTC)

ECS00AWE

HOW TO READ DTC AND 1ST TRIP DTC

DTC and 1st trip DTC can be read by the following methods.

( with **CONSULT-II** or ( **GST**) CONSULT-II or GST (Generic Scan Tool) Examples: P0705, P0720 etc. These DTC are prescribed by SAE J2012.

(CONSULT-II also displays the malfunctioning component or system.)

- **1st trip DTC No. is the same as DTC No.**
- **Output of the diagnostic trouble code indicates that the indicated circuit has a malfunction. However, in case of the Mode II and GST, they do not indicate whether the malfunction is still occurring or occurred in the past and returned to normal. CONSULT-II can identify them as shown below, therefore, CONSULT-II (if available) is recommended.**

A sample of CONSULT-II display for DTC and 1st trip DTC is shown on the next page. DTC or 1st trip DTC of a malfunction is displayed in SELF-DIAGNOSTIC RESULTS mode for "ENGINE" with CONSULT-II. Time data indicates how many times the vehicle was driven after the last detection of a DTC.

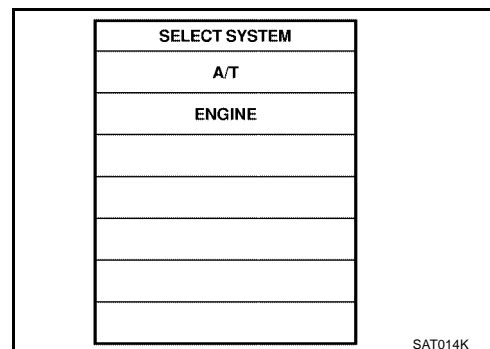

ON BOARD DIAGNOSTIC (OBD) SYSTEM

If the DTC is being detected currently, the time data will be "0".

SELF-DIAG RESULTS	
DTC RESULTS	TIME
PNP SW/CIRC [P0705]	0

SAT015K

If a 1st trip DTC is stored in the ECM, the time data will be "1 t".

SELF-DIAG RESULTS	
DTC RESULTS	TIME
PNP SW/CIRC [P0705]	1 t

SAT016K

Freeze Frame Data and 1st Trip Freeze Frame Data

The ECM has a memory function, which stores the driving condition such as fuel system status, calculated load value, engine coolant temperature, short term fuel trim, long term fuel trim, engine speed and vehicle speed at the moment the ECM detects a malfunction.

Data which are stored in the ECM memory, along with the 1st trip DTC, are called 1st trip freeze frame data, and the data, stored together with the DTC data, are called freeze frame data and displayed on CONSULT-II or GST. The 1st trip freeze frame data can only be displayed on the CONSULT-II screen, not on the GST. For detail, refer to [AT-39, "ON BOARD DIAGNOSTIC \(OBD\) SYSTEM"](#).

Only one set of freeze frame data (either 1st trip freeze frame data or freeze frame data) can be stored in the ECM. 1st trip freeze frame data is stored in the ECM memory along with the 1st trip DTC. There is no priority for 1st trip freeze frame data and it is updated each time a different 1st trip DTC is detected. However, once freeze frame data (2nd trip detection/MIL on) is stored in the ECM memory, 1st trip freeze frame data is no longer stored. Remember, only one set of freeze frame data can be stored in the ECM. The ECM has the following priorities to update the data.

Priority	Items
1	Freeze frame data Misfire — DTC: P0300 - P0306 Fuel Injection System Function — DTC: P0171, P0172, P0174, P0175
2	Except the above items (Includes A/T related items)
3	1st trip freeze frame data

Both 1st trip freeze frame data and freeze frame data (along with the DTC) are cleared when the ECM memory is erased.

HOW TO ERASE DTC

The diagnostic trouble code can be erased by CONSULT-II, GST or ECM DIAGNOSTIC TEST MODE as described following.

- If the battery cable is disconnected, the diagnostic trouble code will be lost within 24 hours.
- When you erase the DTC, using CONSULT-II or GST is easier and quicker than switching the mode selector on the ECM.

The following emission-related diagnostic information is cleared from the ECM memory when erasing DTC related to OBD-II. For details, refer to [EC-49, "Emission-related Diagnostic Information"](#).

- Diagnostic trouble codes (DTC)
- 1st trip diagnostic trouble codes (1st trip DTC)
- Freeze frame data

ON BOARD DIAGNOSTIC (OBD) SYSTEM

- 1st trip freeze frame data
- System readiness test (SRT) codes
- Test values

HOW TO ERASE DTC (WITH CONSULT-II)

- If a DTC is displayed for both ECM and TCM, it is necessary to be erased for both ECM and TCM.
1. If the ignition switch stays "ON" after repair work, be sure to turn ignition switch "OFF" once. Wait at least 10 seconds and then turn it "ON" (engine stopped) again.
 2. Turn CONSULT-II "ON" and touch "A/T".
 3. Touch "SELF-DIAG RESULTS".
 4. Touch "ERASE". (The DTC in the TCM will be erased.) Then touch "BACK" twice.
 5. Touch "ENGINE".
 6. Touch "SELF-DIAG RESULTS".
 7. Touch "ERASE". (The DTC in the ECM will be erased.)

How to erase DTC (With CONSULT-II)

1. If the ignition switch stays "ON" after repair work, be sure to turn ignition switch "OFF" once. Wait at least 10 seconds and then turn it "ON" (engine stopped) again.

SELECT SYSTEM
A/T
ENGINE

2. Turn CONSULT-II "ON", and touch "A/T".

SELECT DIAG MODE
SELF-DIAG RESULTS
DATE MONITOR
CAN DIAG SUPPORT MNTR
DTC WORK SUPPORT
ECU PART NUMBER

3. Touch "SELF-DIAG RESULTS".

SELF-DIAG RESULTS
DTC RESULTS
TCC SOLENOID/CIRC [P0740]

4. Touch "ERASE". (The DTC in the TCM will be erased.)

Touch "BACK".

Touch "BACK".

SELECT SYSTEM
A/T
ENGINE

5. Touch "ENGINE".

SELECT DIAG MODE
WORK SUPPORT
SELF-DIAG RESULTS
DATA MONITOR
DATA MONITOR(SPEC)
CAN DIAG SUPPORT MNTR
ACTIVE TEST

6. Touch "SELF-DIAG RESULTS".

SELF-DIAG RESULTS	
DTC RESULTS	TIME
TCC SOLENOID/CIRC [P0740]	0

7. Touch "ERASE". (The DTC in the ECM will be erased.)

SCIA5334E

HOW TO ERASE DTC (WITH GST)

1. If the ignition switch stays "ON" after repair work, be sure to turn ignition switch "OFF" once. Wait at least 10 seconds and then turn it "ON" (engine stopped) again.
2. Select Mode 4 with Generic Scan Tool (GST). For details refer to [EC-136, "Generic Scan Tool \(GST\) Function"](#).

HOW TO ERASE DTC (NO TOOLS)

1. Disconnect battery for 24 hours.
2. Reconnect battery.

ON BOARD DIAGNOSTIC (OBD) SYSTEM

Malfunction Indicator Lamp (MIL)

ECS00AWF

DESCRIPTION

The MIL is located on the instrument panel.

1. The MIL will light up when the ignition switch is turned "ON" without the engine running. This is a bulb check.
 - If the MIL does not light up, refer to [DI-30, "WARNING LAMPS"](#).
2. When the engine is started, the MIL should go off. If the MIL remains on, the on board diagnostic system has detected an engine system malfunction.

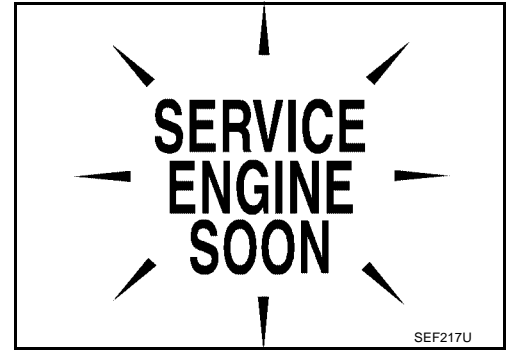

TROUBLE DIAGNOSIS

PF0:00004

TROUBLE DIAGNOSIS

DTC Inspection Priority Chart

ECS00AWG

If some DTCs are displayed at the same time, perform inspections one by one based on the following priority chart.

NOTE:

If DTC U1000 is displayed with other DTCs, first perform the trouble diagnosis for DTC U1000. Refer to [AT-97](#).

Priority	Detected items (DTC)
1	U1000 CAN communication line
2	Except above

Fail-Safe

ECS00AWH

The TCM has an electrical fail-safe mode. This mode makes it possible to operate even if there is an error in a main electronic control input/output signal circuit.

In fail-safe mode the transmission is fixed in 2nd, 4th, or 5th (depending on the breakdown position), so the customer should feel "slipping" or "poor acceleration".

Even when the electronic circuits are normal, under special conditions (for example, when slamming on the brake with the wheels spinning drastically and stopping the tire rotation), the transmission can go into fail-safe mode. If this happens, switch "OFF" the ignition switch for 10 seconds, then switch it "ON" again to return to the normal shift pattern. Therefore, the customer's vehicle has returned to normal, so handle according to the "diagnostics flow" (Refer to [AT-46, "WORK FLOW"](#)).

FAIL-SAFE FUNCTION

If any malfunction occurs in a sensor or solenoid, this function controls the A/T to mark driving possible.

Vehicle Speed Sensor

- Signals are input from two systems - from vehicle speed sensor A/T (revolution sensor) installed on the transmission and from combination meter so normal driving is possible even if there is a malfunction in one of the systems. And if vehicle speed sensor A/T (revolution sensor) has unusual cases, 5th gear and manual mode are prohibited.

Accelerator Pedal Position Sensor

- If there is a malfunction in one of the systems, the accelerator opening angle is controlled by ECM according to a pre-determined accelerator angle to make driving possible. And if there are malfunctions in tow systems, the engine speed is fixed by ECM to a pre-determined engine speed to make driving possible.

Throttle Position Sensor

- If there is a malfunction in one of the systems, the accelerator opening angle is controlled by ECM according to a pre-determined accelerator angle to make driving possible. And if there are malfunctions in tow systems, the accelerator opening angle is controlled by the idle signal sent from the ECM which is based on input indicating either idle condition or off-idle condition (pre-determined accelerator opening) in order to make driving possible.

PNP Switch

- In the unlikely event that a malfunction signal enters the TCM, the position indicator is switched "OFF", the starter relay is switched "OFF" (starter starting is disabled), the back-up lamp relay switched "OFF" (back-up lamp is OFF) and the position is fixed to the "D" range to make driving possible.

Starter Relay

- The starter relay is switched "OFF". (Starter starting is disabled.)

TROUBLE DIAGNOSIS

A/T Interlock

- If there is an A/T interlock judgment malfunction, the transmission is fixed in 2nd gear to make driving possible.

NOTE:

When the vehicle is driven fixed in 2nd gear, a turbine revolution sensor malfunction is displayed, but this is not a turbine revolution sensor malfunction.

- When the coupling pattern below is detected, the fail-safe action corresponding to the pattern is performed.

A/T INTERLOCK COUPLING PATTERN TABLE

●: NG X: OK

Gear position		ATF pressure switch output					Fail-safe function	Clutch pressure output pattern after fail-safe function					
		SW3 (I/C)	SW6 (HLR/C)	SW5 (D/C)	SW1 (FR/B)	SW2 (LC/B)		I/C	HLR/C	D/C	FR/B	LC/B	L/U
A/T inter-lock coupling pattern	3rd	–	X	X	–	●	Held in 2nd gear	OFF	OFF	ON	OFF	OFF	OFF
	4th	–	X	X	–	●	Held in 2nd gear	OFF	OFF	ON	OFF	OFF	OFF
	5th	X	X	–	X	●	Held in 2nd gear	OFF	OFF	ON	OFF	OFF	OFF

A/T 1st Engine Braking

- When there is an A/T first gear engine brake judgment malfunction, the low coast brake solenoid is switched “OFF” to avoid the engine brake operation.

Line Pressure Solenoid

- The solenoid is switched “OFF” and the line pressure is set to the maximum hydraulic pressure to make driving possible.

Torque Converter Clutch Solenoid

- The solenoid is switched “OFF” to release the lock-up.

Low Coast Brake Solenoid

- When a (electrical or functional) malfunction occurs, in order to make driving possible, the engine brake is not applied in 1st and 2nd gear.

Input Clutch Solenoid

- If a (electrical or functional) malfunction occurs with the solenoid either “ON” or “OFF”, the transmission is held in 4th gear to make driving possible.

Direct Clutch Solenoid

- If a (electrical or functional) malfunction occurs with the solenoid either “ON” or “OFF”, the transmission is held in 4th gear to make driving possible.

Front Brake Clutch Solenoid

- If a (electrical or functional) malfunction occurs with the solenoid “ON”, in order to make driving possible, the A/T is held in 5th gear; if the solenoid is OFF, 4th gear.

High & Low Reverse Clutch Solenoid

- If a (electrical or functional) malfunction occurs with the solenoid either “ON” or “OFF”, the transmission is held in 4th gear to make driving possible.

Turbine Revolution Sensor 1 or 2

- The control is the same as if there were no turbine revolution sensors, 5th gear and manual mode are prohibited.

TROUBLE DIAGNOSIS

How To Perform Trouble Diagnosis For Quick and Accurate Repair INTRODUCTION

ECS00AWI

The TCM receives a signal from the vehicle speed sensor, accelerator pedal position sensor (throttle position sensor) or PNP switch and provides shift control or lock-up control via A/T solenoid valves.

The TCM also communicates with the ECM by means of a signal sent from sensing elements used with the OBD-related parts of the A/T system for malfunction-diagnostic purposes. The TCM is capable of diagnosing malfunctioning parts while the ECM can store malfunctions in its memory.

Input and output signals must always be correct and stable in the operation of the A/T system. The A/T system must be in good operating condition and be free of valve seizure, solenoid valve malfunction, etc.

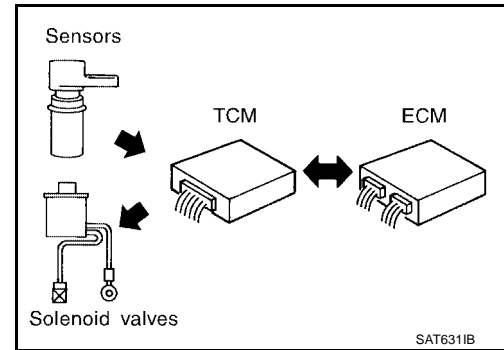

It is much more difficult to diagnose a error that occurs intermittently rather than continuously. Most intermittent errors are caused by poor electric connections or improper wiring. In this case, careful checking of suspected circuits may help prevent the replacement of good parts.

A visual check only may not find the cause of the errors. A road test with CONSULT-II (or GST) or a circuit tester connected should be performed. Follow the [AT-46. "WORK FLOW"](#) .

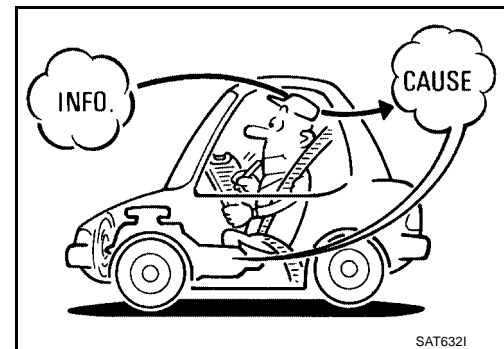

Before undertaking actual checks, take a few minutes to talk with a customer who approaches with a driveability complaint. The customer can supply good information about such errors, especially intermittent ones. Find out what symptoms are present and under what conditions they occur. A "Diagnostic Worksheet" as shown on the example (Refer to [AT-47](#)) should be used.

Start your diagnosis by looking for "conventional" errors first. This will help troubleshoot driveability errors on an electronically controlled engine vehicle.

Also check related Service bulletins.

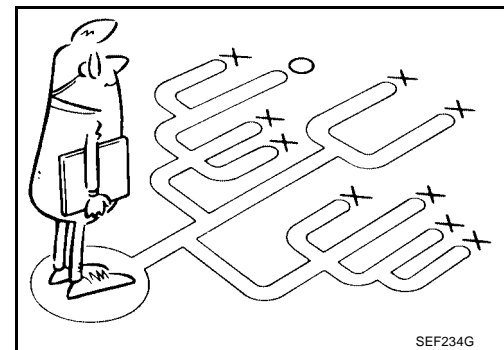

A
B
AT
D
E
F
G
H
I
J
K
L
M

TROUBLE DIAGNOSIS

WORK FLOW

A good understanding of the malfunction conditions can make troubleshooting faster and more accurate. In general, each customer feels differently about a malfunction. It is important to fully understand the symptoms or conditions for a customer complaint. Make good use of the two sheets provided, "Information From Customer" (Refer to [AT-47](#)) and "Diagnostic Worksheet" (Refer to [AT-47](#)), to perform the best troubleshooting possible.

Work Flow Chart

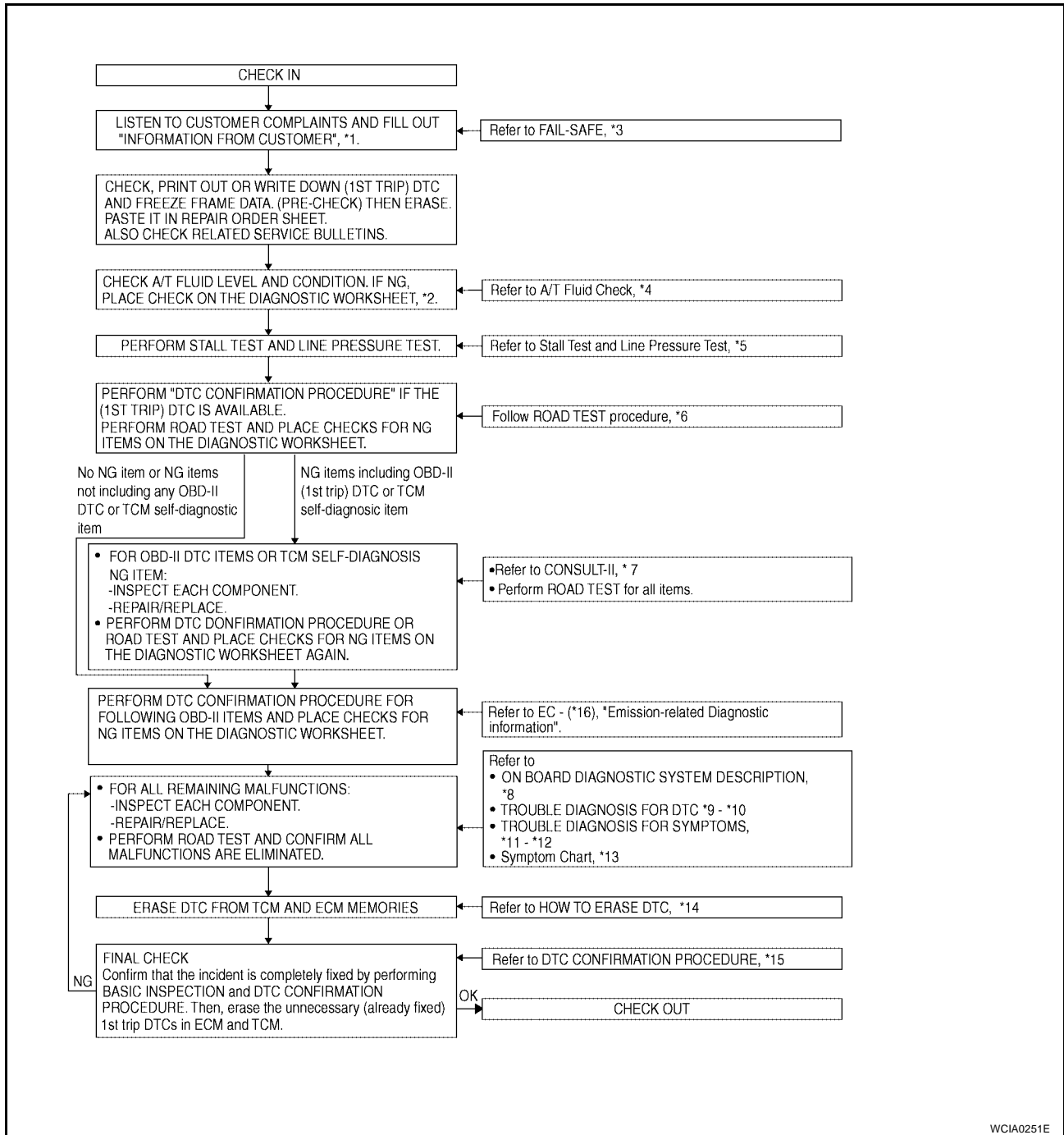

- *1. [AT-47](#)
- *4. [AT-52](#)
- *7. [AT-85](#)
- *10. [AT-178](#)
- *13. [AT-63](#)
- *16. [EC-49](#)

- *2. [AT-47](#)
- *5. [AT-52, AT-53](#)
- *8. [AT-39](#)
- *11. [AT-183](#)
- *14. [AT-40](#)

- *3. [AT-43](#)
- *6. [AT-55](#)
- *9. [AT-97](#)
- *12. [AT-233](#)
- *15. [AT-97, AT-172](#)

TROUBLE DIAGNOSIS

	<input type="checkbox"/> Perform all road tests and enter checks in required inspection items.	AT-55
4	Check before engine is started <input type="checkbox"/> The AT CHECK Indicator Lamp does come on. AT-186 . <input type="checkbox"/> Perform self-diagnostics Enter checks for detected items.	AT-56
	<input type="checkbox"/> AT-109, "DTC P0720 VEHICLE SPEED SENSOR A/T (REVOLUTION SENSOR)" . <input type="checkbox"/> AT-134, "DTC P1721 VEHICLE SPEED SENSOR MTR" . <input type="checkbox"/> AT-149, "DTC P1762 DIRECT CLUTCH SOLENOID VALVE" . <input type="checkbox"/> AT-116, "DTC P0740 TORQUE CONVERTER CLUTCH SOLENOID VALVE" . <input type="checkbox"/> AT-120, "DTC P0745 LINE PRESSURE SOLENOID VALVE" . <input type="checkbox"/> AT-141, "DTC P1752 INPUT CLUTCH SOLENOID VALVE" . <input type="checkbox"/> AT-145, "DTC P1757 FRONT BRAKE SOLENOID VALVE" . <input type="checkbox"/> AT-157, "DTC P1772 LOW COAST BRAKE SOLENOID VALVE" . <input type="checkbox"/> AT-153, "DTC P1767 HIGH AND LOW REVERSE CLUTCH SOLENOID VALVE" . <input type="checkbox"/> AT-105, "DTC P0705 PARK/NEUTRAL POSITION SWITCH" . <input type="checkbox"/> AT-127, "DTC P1710 A/T FLUID TEMPERATURE SENSOR CIRCUIT" . <input type="checkbox"/> AT-132, "DTC P1716 TURBINE REVOLUTION SENSOR" . <input type="checkbox"/> AT-136, "DTC P1730 A/T INTERLOCK" . <input type="checkbox"/> AT-139, "DTC P1731 A/T 1ST ENGINE BRAKING" . <input type="checkbox"/> AT-100, "DTC P0615 START SIGNAL CIRCUIT" . <input type="checkbox"/> AT-124, "DTC P1705 THROTTLE POSITION SENSOR" . <input type="checkbox"/> AT-114, "DTC P0725 ENGINE SPEED SIGNAL" . <input type="checkbox"/> AT-97, "DTC U1000 CAN COMMUNICATION LINE" . <input type="checkbox"/> Battery <input type="checkbox"/> Other	
	4-1.	
4-2.	Idle inspection	
	<input type="checkbox"/> AT-186, "Engine Cannot Be Started In "P" or "N" Position" . <input type="checkbox"/> AT-187, "In "P" Position, Vehicle Moves When Pushed" . <input type="checkbox"/> AT-188, "In "N" Position, Vehicle Moves" . <input type="checkbox"/> AT-189, "Large Shock ("N" to "D" Position)" . <input type="checkbox"/> AT-192, "Vehicle Does Not Creep Backward In "R" Position" . <input type="checkbox"/> AT-195, "Vehicle Does Not Creep Forward In "D" Position" .	AT-56
4-3.	Driving tests	
	Part 1 <input type="checkbox"/> AT-197, "Vehicle Cannot Be Started From D1" . <input type="checkbox"/> AT-200, "A/T Does Not Shift: D1 → D2" . <input type="checkbox"/> AT-202, "A/T Does Not Shift: D2 → D3" . <input type="checkbox"/> AT-204, "A/T Does Not Shift: D3 → D4" . <input type="checkbox"/> AT-207, "A/T Does Not Shift: D4 → D5" . <input type="checkbox"/> AT-209, "A/T Does Not Perform Lock-up" . <input type="checkbox"/> AT-211, "A/T Does Not Hold Lock-up Condition" . <input type="checkbox"/> AT-213, "Lock-up Is Not Released" . <input type="checkbox"/> AT-214, "Engine Speed Does Not Return To Idle" .	AT-57

TROUBLE DIAGNOSIS

4	4-3	Part 2		AT-59	A
		<input type="checkbox"/> AT-197, "Vehicle Cannot Be Started From D1" . <input type="checkbox"/> AT-200, "A/T Does Not Shift: D1 → D2" . <input type="checkbox"/> AT-202, "A/T Does Not Shift: D2 → D3" . <input type="checkbox"/> AT-204, "A/T Does Not Shift: D3 → D4" .			B
		Part 3		AT-60	AT
		Column shift models	<input type="checkbox"/> AT-215, "Cannot Be Changed to Manual Mode (Column Shift)" . <input type="checkbox"/> AT-215, "A/T Does Not Shift: 5th gear → 4th gear (Floor Shift Models)" . <input type="checkbox"/> AT-220, "A/T Does Not Shift: 4th gear → 3rd gear (Floor Shift Models)" . <input type="checkbox"/> AT-224, "A/T Does Not Shift: 3rd gear → 2nd gear (Floor Shift Models)" . <input type="checkbox"/> AT-228, "A/T Does Not Shift: 2nd gear → 1st gear (Floor Shift Models)" . <input type="checkbox"/> AT-233, "Vehicle Does Not Decelerate By Engine Brake" . <input type="checkbox"/> Perform self-diagnostics Enter checks for detected items.		D
		Floor shift models	<input type="checkbox"/> AT-215, "A/T Does Not Shift: 5th gear → 4th gear (Floor Shift Models)" . <input type="checkbox"/> AT-220, "A/T Does Not Shift: 4th gear → 3rd gear (Floor Shift Models)" . <input type="checkbox"/> AT-224, "A/T Does Not Shift: 3rd gear → 2nd gear (Floor Shift Models)" . <input type="checkbox"/> AT-228, "A/T Does Not Shift: 2nd gear → 1st gear (Floor Shift Models)" . <input type="checkbox"/> AT-233, "Vehicle Does Not Decelerate By Engine Brake" . <input type="checkbox"/> Perform self-diagnostics Enter checks for detected items.	E	
		<input type="checkbox"/> AT-109, "DTC P0720 VEHICLE SPEED SENSOR A/T (REVOLUTION SENSOR)" . <input type="checkbox"/> AT-134, "DTC P1721 VEHICLE SPEED SENSOR MTR" . <input type="checkbox"/> AT-149, "DTC P1762 DIRECT CLUTCH SOLENOID VALVE" . <input type="checkbox"/> AT-116, "DTC P0740 TORQUE CONVERTER CLUTCH SOLENOID VALVE" . <input type="checkbox"/> AT-120, "DTC P0745 LINE PRESSURE SOLENOID VALVE" . <input type="checkbox"/> AT-141, "DTC P1752 INPUT CLUTCH SOLENOID VALVE" . <input type="checkbox"/> AT-145, "DTC P1757 FRONT BRAKE SOLENOID VALVE" . <input type="checkbox"/> AT-157, "DTC P1772 LOW COAST BRAKE SOLENOID VALVE" . <input type="checkbox"/> AT-153, "DTC P1767 HIGH AND LOW REVERSE CLUTCH SOLENOID VALVE" . <input type="checkbox"/> AT-105, "DTC P0705 PARK/NEUTRAL POSITION SWITCH" . <input type="checkbox"/> AT-127, "DTC P1710 A/T FLUID TEMPERATURE SENSOR CIRCUIT" . <input type="checkbox"/> AT-132, "DTC P1716 TURBINE REVOLUTION SENSOR" . <input type="checkbox"/> AT-136, "DTC P1730 A/T INTERLOCK" . <input type="checkbox"/> AT-139, "DTC P1731 A/T 1ST ENGINE BRAKING" . <input type="checkbox"/> AT-100, "DTC P0615 START SIGNAL CIRCUIT" . <input type="checkbox"/> AT-124, "DTC P1705 THROTTLE POSITION SENSOR" . <input type="checkbox"/> AT-114, "DTC P0725 ENGINE SPEED SIGNAL" . <input type="checkbox"/> AT-97, "DTC U1000 CAN COMMUNICATION LINE" . <input type="checkbox"/> Battery <input type="checkbox"/> Other		F	
5	<input type="checkbox"/> Inspect each system for items found to be NG in the self-diagnostics and repair or replace the malfunction parts.		G		
6	<input type="checkbox"/> Perform all road tests and enter the checks again for the required items.		H		
7	<input type="checkbox"/> For any remaining NG items, perform the "diagnostics procedure" and repair or replace the malfunction parts. See the chart for diagnostics by symptoms. (This chart also contains other symptoms and inspection procedures.)		I		
8	<input type="checkbox"/> Erase the results of the self-diagnostics from the TCM.		J		
				K	
				L	
				M	
				K	
				L	
				M	

TROUBLE DIAGNOSIS

A/T Electrical Parts Location

ECS00AWJ

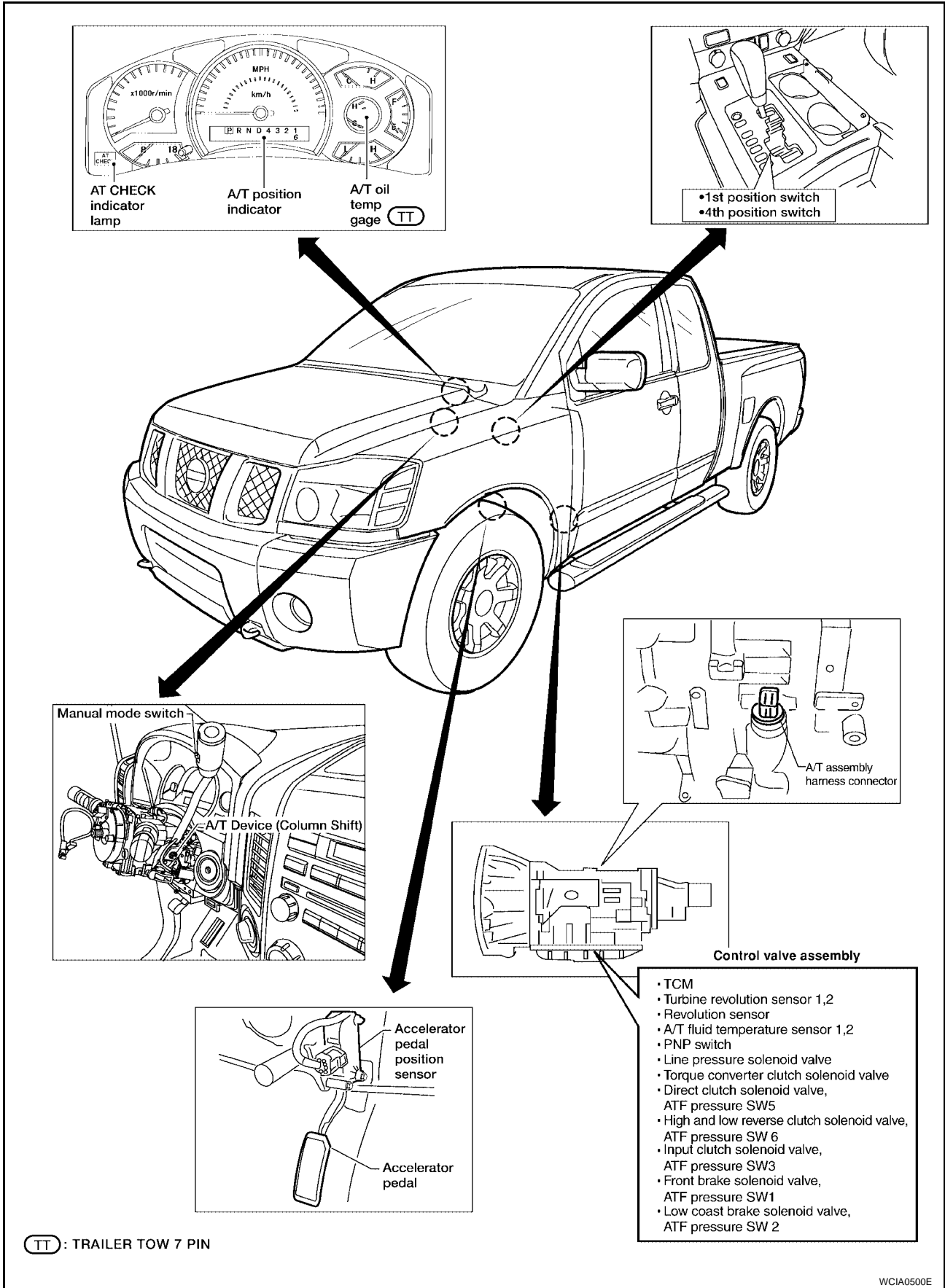

WCIA0500E

TROUBLE DIAGNOSIS

ECS00AWM

Inspections Before Trouble Diagnosis

A/T FLUID CHECK

Fluid Leakage and Fluid Level Check

- Inspect for fluid leakage and check the fluid level. Refer to [AT-12, "Checking A/T Fluid"](#).

Fluid Condition Check

Inspect the fluid condition.

Fluid condition	Conceivable Cause	Required Operation
Varnished (viscous varnish state)	Clutch, brake scorched	Replace the ATF and check the A/T main unit and the vehicle for malfunctions (wire harnesses, cooler pipes, etc.)
Milky white or cloudy	Water in the fluid	Replace the ATF and check for places where water is getting in.
Large amount of metal powder mixed in	Unusual wear of sliding parts within A/T	Replace the ATF and check for improper operation of the A/T.

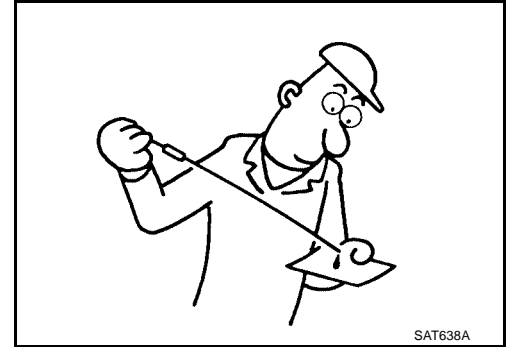

STALL TEST

Stall Test Procedure

1. Inspect the amount of engine oil. Replenish the engine oil if necessary.
2. Drive for about 10 minutes to warm up the vehicle so that the A/T fluid temperature is 50 to 80°C (122 to 176°F). Inspect the amount of ATF. Replenish if necessary.

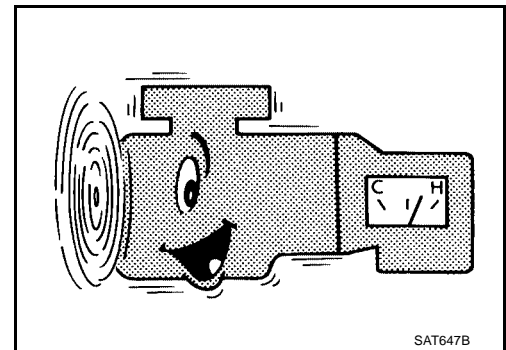

3. Securely engage the parking brake so that the tires do not turn.

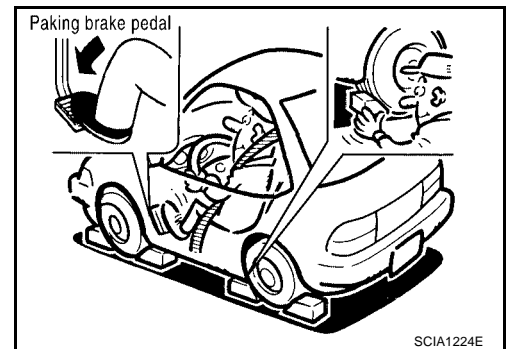

4. Engine start, apply foot brake, and place selector lever in "D" position.
5. While holding down the foot brake, gradually press down the accelerator pedal.
6. Quickly read off the stall speed, then quickly remove your foot from the accelerator pedal.

CAUTION:

Do not hold down the accelerator pedal for more than 5 seconds during this test.

7. Move the selector lever to the "N" position.
8. Cool down the ATF.

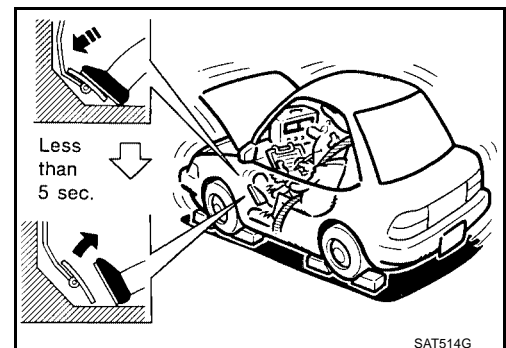

TROUBLE DIAGNOSIS

CAUTION:

Run the engine at idle for at least one minute.

Stall speed: 2,500 - 2,800 rpm

Judgement of Stall Test

	Selector lever position		Expected problem location
	D	R	
Stall rotation	H	O	<ul style="list-style-type: none"> ● Forward brake ● Forward one-way clutch ● 1st one-way clutch ● 3rd one-way clutch
	O	H	<ul style="list-style-type: none"> ● Reverse clutch
	L	L	<ul style="list-style-type: none"> ● Engine and torque converter one-way clutch
	H	H	<ul style="list-style-type: none"> ● Line pressure low

O: Stall speed within standard value position

H: Stall speed higher than standard value

L: Stall speed lower than standard value

Stall test standard value position

Does not shift-up D, M position 1 → 2	Slipping in 2nd, 3rd, 4th gears	Direct clutch slippage
Does not shift-up D, M position 2 → 3	Slipping in 3rd, 4th, 5th gears	High and low reverse clutch slippage
Does not shift-up D, M position 3 → 4	Slipping in 4th, 5th gears	Input clutch slippage
Does not shift-up D, M position 4 → 5	Slipping in 5th gear	Front brake slippage

LINE PRESSURE TEST

Line Pressure Test Port

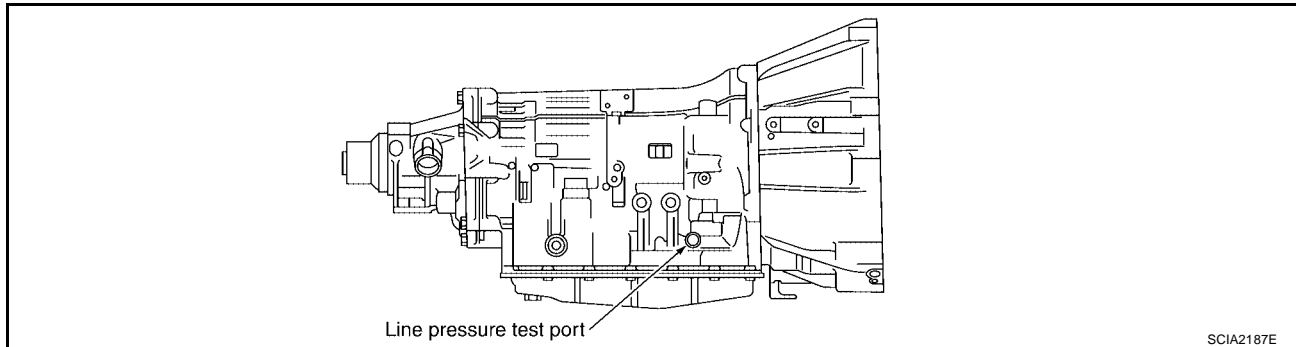

Line Pressure Test Procedure

1. Inspect the amount of engine oil and replenish if necessary.
2. Drive the car for about 10 minutes to warm it up so that the ATF reaches in range of 50 to 80°C (122 to 176°F), then inspect the amount of ATF and replenish if necessary.

NOTE:

The automatic fluid temperature rises in range of 50 to 80°C (122 to 176°F) during 10 minutes of driving.

TROUBLE DIAGNOSIS

3. After warming up remove the oil pressure detection plug and install the oil pressure gauge [ST2505S001(J-34301-C)].

CAUTION:

When using the oil pressure gauge, be sure to use the O-ring attached to the oil pressure detection plug.

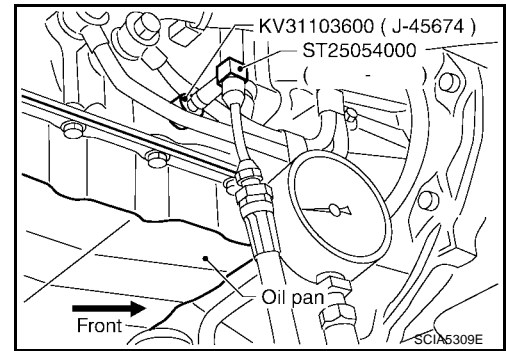

4. Securely engage the parking brake so that the tires do not turn.

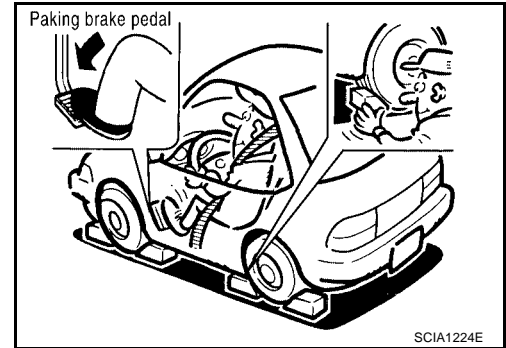

5. Start the engine, then measure the line pressure at both idle and the stall speed.

CAUTION:

- Keep the brake pedal pressed all the way down during measurement.
- When measuring the line pressure at the stall speed, refer to [AT-52, "STALL TEST"](#).

6. After the measurements are complete, install the oil pressure detection plug and tighten to the regulation torque below.

 : 7.3 N·m (0.74 kg·m, 65 in·lb)

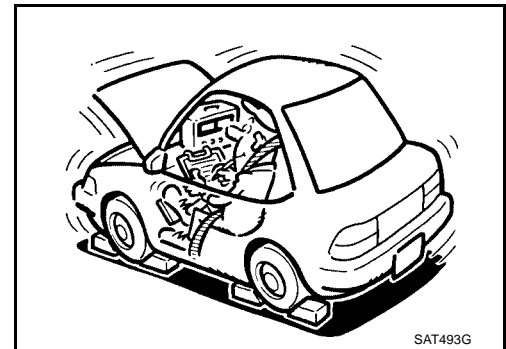

CAUTION:

Do not reuse the O-ring.

Line Pressure

Engine speed	Line pressure [kPa (kg/cm ² , psi)]	
	R position	D, M position
At idle speed	392 - 441 (4.0 - 4.5, 57 - 64)	373 - 422 (3.8 - 4.3, 54 - 61)
At stall speed	1,700 - 1,890 (17.3 - 19.3, 247 - 274)	1,310 - 1,500 (13.3 - 15.3, 190 - 218)

TROUBLE DIAGNOSIS

Judgement of Line Pressure Test

Judgement		Possible cause	
Idle speed	Low for all positions (P, R, N, D, M)	Possible causes include malfunctions in the pressure supply system and low oil pump output. For example <ul style="list-style-type: none"> ● Oil pump wear ● Pressure regulator valve or plug sticking or spring fatigue ● Oil strainer ⇒ oil pump ⇒ pressure regulator valve passage oil leak ● Engine idle speed too low 	A B AT
	Only low for a specific position	Possible causes include an oil pressure leak in a passage or device related to the position after the pressure is distributed by the manual valve.	
	High	Possible causes include a sensor malfunction or malfunction in the line pressure adjustment function. For example <ul style="list-style-type: none"> ● Accelerator pedal position signal malfunction ● ATF temperature sensor malfunction ● Line pressure solenoid malfunction (sticking in "OFF" state, filter clog, cut line) ● Pressure regulator valve or plug sticking 	D E F
Stall speed	Oil pressure does not rise higher than the oil pressure for idle.	Possible causes include a sensor malfunction or malfunction in the pressure adjustment function. For example <ul style="list-style-type: none"> ● Accelerator pedal position signal malfunction ● TCM breakdown ● Line pressure solenoid malfunction (shorting, sticking in "ON" state) ● Pressure regulator valve or plug sticking ● Pilot valve sticking or pilot filter clogged 	G H
	The pressure rises, but does not enter the standard position.	Possible causes include malfunctions in the pressure supply system and malfunction in the pressure adjustment function. For example <ul style="list-style-type: none"> ● Accelerator pedal position signal malfunction ● Line pressure solenoid malfunction (sticking, filter clog) ● Pressure regulator valve or plug sticking ● Pilot valve sticking or pilot filter clogged 	I J
	Only low for a specific position	Possible causes include an oil pressure leak in a passage or device related to the position after the pressure is distributed by the manual valve.	K

ROAD TEST

Description

- The road test inspects overall performance of the A/T and analyzes possible malfunction causes.
 - The road test is carried out in the following three stages.
1. Check before engine is started. Refer to [AT-56](#) .
 2. Check at idle. Refer to [AT-56](#) .
 3. Cruise test
 - Inspect all the items from Part 1 to Part 3. Refer to [AT-57](#) , [AT-59](#) , [AT-60](#) .
 - Before beginning the road test, check the test procedure and inspection items.
 - Test all inspection items until the symptom is uncovered. Diagnose NG items when all road tests are complete.

TROUBLE DIAGNOSIS

Check Before Engine is Started

ECS00AWN

1. CHECK AT CHECK INDICATOR LAMP

1. Park vehicle on level surface.
2. Move selector lever to "P" position.
3. Turn ignition switch to "OFF" position and wait at least 10 seconds.
4. Turn ignition switch to "ON" position. (Do not start engine.)

Does AT CHECK indicator lamp light up for about 2 seconds?

YES >> 1. Turn ignition switch to "OFF" position.

2. Carry out the self-diagnostics and record all NG items on the diagnostic worksheet. Refer to [AT-87, "CONSULT-II SETTING PROCEDURE"](#) .

3. Go to [AT-56, "Check at Idle"](#) .

NO >> Stop the road test and go to [AT-186, "AT CHECK Indicator Lamp does not come on"](#) .

Check at Idle

ECS00AWO

1. CHECK STARTING THE ENGINE

1. Park vehicle on level surface.
2. Move selector lever to "P" or "N" position.
3. Turn ignition switch to "OFF" position.
4. Turn ignition switch to "START" position.

Does the engine start?

YES >> GO TO 2.

NO >> Stop the road test and go to [AT-186, "Engine Cannot Be Started In "P" or "N" Position"](#) .

2. CHECK STARTING THE ENGINE

1. Turn ignition switch to "ON" position.
2. Move selector lever in "D" or "R" position.
3. Turn ignition switch to "START" position.

Does the engine start in either position?

YES >> Stop the road test and go to [AT-186, "Engine Cannot Be Started In "P" or "N" Position"](#) .

NO >> GO TO 3.

3. CHECK "P" POSITION FUNCTIONS

1. Move selector lever to "P" position.
2. Turn ignition switch to "OFF" position.
3. Release the parking brake.
4. Push the vehicle forward or backward.
5. Engage the parking brake.

When you push the vehicle with disengaging the parking brake, does it move?

YES >> Enter a check mark at "In "N" Position Vehicle Moves When Pushed" on the diagnostics worksheet, then continue the road test.

NO >> GO TO 4.

TROUBLE DIAGNOSIS

4. CHECK "N" POSITION FUNCTIONS

1. Start the engine.
2. Move selector lever to "N" position.
3. Release the parking brake.

Does vehicle move forward or backward?

- YES >> Enter a check mark at "In "P" Position Vehicle Moves" on the diagnostics worksheet, then continue the road test.
- NO >> GO TO 5.

5. CHECK SHIFT SHOCK

1. Engage the brake.
2. Move selector lever to "D" position.

When the transmission is shifted from "N" to "D", is there an excessive shock?

- YES >> Enter a check mark at "Large Shock ("N" to "D" Position)" on the diagnostics worksheet, then continue the road test.
- NO >> GO TO 6.

6. CHECK "R" POSITION FUNCTIONS

1. Engage the brake.
2. Move selector lever to "R" position.
3. Release the brake for 4 to 5 seconds.

Does the vehicle creep backward?

- YES >> GO TO 7.
- NO >> Enter a check mark at "Vehicle Does Not Creep Backward In "R" Position" on the diagnostics worksheet, then continue the road test.

7. CHECK "D" POSITION FUNCTIONS

Inspect whether the vehicle creeps forward when the transmission is put into the "D" position.

Does the vehicle move forward in the "D" positions?

- YES >> Go to [AT-57, "Cruise Test - Part 1"](#) , [AT-59, "Cruise Test - Part 2"](#) , and [AT-60, "Cruise Test - Part 3"](#) .
- NO >> Enter a check mark at "Vehicle Does Not Creep Forward In "D" Position" on the diagnostics worksheet, then continue the road test.

Cruise Test - Part 1

ECS00AWP

1. CHECK STARTING OUT FROM D1

1. Drive the vehicle for about 10 minutes to warm up the engine oil and ATF.
Appropriate temperature for the ATF: 50 - 80°C (122 - 176°F)
2. Park the vehicle on a level surface.
3. Move selector lever to "P" position.
4. Start the engine.
5. Move selector lever to "D" position.
6. Press the accelerator pedal about half way down to accelerate the vehicle.

 **With CONSULT-II**

Read off the gear positions.

Starts from D1?

- YES >> GO TO 2.
- NO >> Enter a check mark at "Vehicle Cannot be Started From D1" on the diagnostics worksheet, then continue the road test.

TROUBLE DIAGNOSIS

2. CHECK SHIFT-UP D1 → D2

Press down the accelerator pedal about half way and inspect if the vehicle shifts up (D1 → D2) at the appropriate speed.

- Refer to [AT-62, "Vehicle Speed When Shifting Gears"](#) .

Ⓜ With CONSULT-II

Read the gear position, throttle degree of opening, and vehicle speed.

Does the A/T shift-up D1 → D2 at the correct speed?

YES >> GO TO 3.

NO >> Enter a check mark at "A/T Does Not Shift: D1 → D2" on the diagnostics worksheet, then continue the road test.

3. CHECK SHIFT-UP D2 → D3

Press down the accelerator pedal about half way and inspect if the vehicle shifts up (D2 → D3) at the appropriate speed.

- Refer to [AT-62, "Vehicle Speed When Shifting Gears"](#) .

Ⓜ With CONSULT-II

Read the gear position, throttle degree of opening, and vehicle speed.

Does the A/T shift-up D2 → D3 at the correct speed?

YES >> GO TO 4.

NO >> Enter a check mark at "A/T Does Not Shift: D2 → D3" on the diagnostics worksheet, then continue the road test.

4. CHECK SHIFT-UP D3 → D4

Press down the accelerator pedal about half way and inspect if the vehicle shifts up (D3 → D4) at the appropriate speed.

- Refer to [AT-62, "Vehicle Speed When Shifting Gears"](#) .

Ⓜ With CONSULT-II

Read the gear position, throttle degree of opening, and vehicle speed.

Does the A/T shift-up D3 → D4 at the correct speed?

YES >> GO TO 5.

NO >> Enter a check mark at "A/T Does Not Shift: D3 → D4" on the diagnostics worksheet, then continue the road test.

5. CHECK SHIFT-UP D4 → D5

Press down the accelerator pedal about half way and inspect if the vehicle shifts up (D4 → D5) at the appropriate speed.

- Refer to [AT-62, "Vehicle Speed When Shifting Gears"](#) .

Ⓜ With CONSULT-II

Read the gear position, throttle degree of opening, and vehicle speed.

Does the A/T shift-up D4 → D5 at the correct speed?

YES >> GO TO 6.

NO >> Enter a check mark at "A/T Does Not Shift: D4 → D5" on the diagnostics worksheet, then continue the road test.

TROUBLE DIAGNOSIS

6. CHECK LOCK-UP

When releasing accelerator pedal from D5, check lock-up from D5 to L/U.

- Refer to [AT-62, "Vehicle Speed When Shifting Gears"](#) .

With CONSULT-II

Select "TCC SOLENOID 0.00A" with the "MAIN SIGNAL" mode for A/T.

Does it lock-up?

YES >> GO TO 7.

NO >> Enter a check mark at "A/T Does Not Perform Lock-up" on the diagnostics worksheet, then continue the road test.

7. CHECK LOCK-UP HOLD

Does it maintain lock-up status?

YES >> GO TO 8.

NO >> Enter a check mark at "A/T Does Not Hold Lock-up Condition" on the diagnostics worksheet, then continue the road test.

8. CHECK LOCK-UP RELEASE

Check lock-up cancellation by depressing brake pedal lightly to decelerate.

With CONSULT-II

Select "TCC SOLENOID 0.00A" with the "MAIN SIGNAL" mode for A/T.

Does lock-up cancel?

YES >> GO TO 9.

NO >> Enter a check mark at "Lock-up Is Not Released" on the diagnostics worksheet, then continue the road test.

9. CHECK SHIFT-DOWN D5 → D4

Decelerate by pressing lightly on the brake pedal.

With CONSULT-II

Read the gear position and engine speed.

When the A/T shift-down D5 → D4, does the engine speed drop smoothly back to idle?

YES >> 1. Stop the vehicle.

2. Go to Cruise test - Part 2 (Refer to [AT-59](#)).

NO >> Enter a check mark at "Engine Speed Does Not Return to Idle" on the diagnostics worksheet, then continue the road test. Go to Cruise test - Part 2 (Refer to [AT-59](#)).

Cruise Test - Part 2

ECS00AWQ

1. CHECK STARTING FROM D1

1. Move selector lever the "D" position.
2. Accelerate at half throttle.

With CONSULT-II

Read the gear position.

Does it start from D1?

YES >> GO TO 2.

NO >> Enter a check mark at "Vehicle Cannot Be Started From D1" on the diagnostics worksheet, then continue the road test.

TROUBLE DIAGNOSIS

2. CHECK SHIFT-UP D1 → D2

Press the accelerator pedal down all the way and inspect whether or not the transmission shifts up (D1 → D2) at the correct speed.

- Refer to [AT-62, "Vehicle Speed When Shifting Gears"](#) .

Ⓜ With CONSULT-II

Read the gear position, throttle position and vehicle speed.

Does the A/T shift-up D1 → D2 at the correct speed?

YES >> GO TO 3.

NO >> Enter a check mark at "Vehicle Does Not Shift: D1 → D2" on the diagnostics worksheet, then continue the road test.

3. CHECK SHIFT-UP D2 → D3

Press the accelerator pedal down all the way and inspect whether or not the transmission shifts up (D2 → D3) at the correct speed.

- Refer to [AT-62, "Vehicle Speed When Shifting Gears"](#) .

Ⓜ With CONSULT-II

Read the gear position, throttle position and vehicle speed.

Does the A/T shift-up D2 → D3 at the correct speed?

YES >> GO TO 4.

NO >> Enter a check mark at "Vehicle Does Not Shift: D2 → D3" on the diagnostics worksheet, then continue the road test.

4. CHECK SHIFT-UP D3 → D4 AND ENGINE BRAKE

When the transmission changes speed D3 → D4, return the accelerator pedal.

Does the A/T shift-up D3 → D4 and apply the engine brake?

YES >> 1. Stop the vehicle.

2. See [AT-60, "Cruise Test - Part 3"](#) .

NO >> Enter a check mark at "Vehicle Does Not Shift: D3 → D4" on the diagnostics worksheet, then continue the road test.

Cruise Test - Part 3

ECS00AWR

1. IDENTIFY SHIFTER LOCATION

Identify the shifter location.

Is the shifter located on the steering column?

YES >> GO TO 2.

NO >> GO TO 4.

2. MANUAL MODE FUNCTION

Move to manual mode from D position.

Does it switch to manual mode?

YES >> GO TO 3.

NO >> Continue road test and add check mark to "Cannot Be Changed to Manual Mode (Column Shift)" on diagnostics worksheet.

TROUBLE DIAGNOSIS

3. CHECK SHIFT-DOWN

During manual mode driving, move gear selector from M5 → M4 → M3 → M2 → M1.

 **With CONSULT-II**

Read the gear position.

Is downshifting correctly performed?

YES >> GO TO 5.

NO >> Enter a check mark at "Vehicle does not shift" at the corresponding position (5th → 4th, 4th → 3rd, 3rd → 2nd, 2nd → 1st) on the diagnostics worksheet, then continue the road test.

4. CHECK SHIFT-DOWN

During D5 driving, move gear selector from D → 4 → 3 → 2 → 1.

 **With CONSULT-II**

Read the gear position.

Is downshifting correctly performed?

YES >> GO TO 5.

NO >> Enter a check mark at "Vehicle does not shift" at the corresponding position (5th → 4th, 4th → 3rd, 3rd → 2nd, 2nd → 1st) on the diagnostics worksheet, then continue the road test.

5. CHECK ENGINE BRAKE

Does engine braking effectively reduce speed in M1 position (column shift) or 11 position (floor shift)?

YES >> 1. Stop the vehicle.

2. Carry out the self-diagnostics. Refer to [AT-87. "CONSULT-II SETTING PROCEDURE"](#) .

NO >> Enter a check mark at "Vehicle Does Not Decelerate By Engine Brake" on the diagnostics worksheet, then continue trouble diagnosis.

TROUBLE DIAGNOSIS

Vehicle Speed When Shifting Gears NORMAL MODE

ECS00AWS

Final gear ratio	Throttle position	Vehicle speed km/h (MPH)							
		D1 →D2	D2 →D3	D3 →D4	D4 →D5	D5 →D4	D4 →D3	D3 →D2	D2 →D1
2.937	Full throttle	70 - 74 (44 - 46)	112 - 120 (70 - 75)	176 - 186 (110 - 116)	249 - 259 (155 - 161)	245 - 255 (152 - 159)	166 - 176 (103 - 110)	100 - 108 (62 - 67)	43 - 47 (27 - 30)
	Half throttle	46 - 50 (29 - 31)	74 - 82 (46 - 51)	103 - 113 (64 - 71)	135 - 145 (84 - 90)	109 - 119 (68 - 74)	69 - 79 (43 - 49)	44 - 52 (28 - 33)	11 - 15 (7 - 10)
3.357	Full throttle	61 - 65 (38 - 41)	97 - 105 (61 - 66)	153 - 163 (95 - 102)	236 - 246 (147 - 153)	232 - 242 (144 - 151)	143 - 153 (89 - 95)	87 - 95 (54 - 59)	43 - 47 (27 - 30)
	Half throttle	41 - 45 (26 - 28)	66 - 74 (41 - 46)	89 - 99 (56 - 62)	117 - 127 (73 - 79)	95 - 105 (59 - 66)	59 - 69 (37 - 43)	38 - 46 (24 - 29)	11 - 15 (7 - 10)

- At half throttle, the accelerator opening is 4/8 of the full opening.

TOW MODE

Final gear ratio	Throttle position	Vehicle speed km/h (MPH)							
		D1 →D2	D2 →D3	D3 →D4	D4 →D5	D5 →D4	D4 →D3	D3 →D2	D2 →D1
2.937	Full throttle	70 - 74 (44 - 46)	112 - 120 (70 - 75)	176 - 186 (110 - 116)	249 - 259 (155 - 161)	245 - 255 (152 - 159)	166 - 176 (103 - 110)	100 - 108 (62 - 67)	43 - 47 (27 - 30)
	Half throttle	50 - 54 (31 - 34)	81 - 89 (50 - 55)	113 - 123 (70 - 76)	135 - 145 (84 - 90)	109 - 119 (68 - 74)	69 - 79 (43 - 49)	44 - 52 (28 - 33)	11 - 15 (7 - 10)
3.357	Full throttle	61 - 65 (38 - 41)	97 - 105 (61 - 66)	153 - 163 (95 - 102)	236 - 246 (147 - 153)	232 - 242 (144 - 151)	143 - 153 (89 - 95)	87 - 95 (54 - 59)	43 - 47 (27 - 30)
	Half throttle	46 - 50 (28 - 31)	72 - 80 (45 - 50)	98 - 108 (61 - 67)	117 - 127 (73 - 79)	95 - 105 (59 - 66)	59 - 69 (37 - 43)	38 - 46 (24 - 29)	11 - 15 (7 - 10)

- At half throttle, the accelerator opening is 4/8 of the full opening.

Vehicle Speed When Performing and Releasing Complete Lock-up

ECS00AWT

Final gear ratio	Throttle position	Vehicle speed km/h (MPH)	
		Lock-up "ON"	Lock-up "OFF"
2.937	Closed throttle	74 - 82 (46 - 51)	71 - 79 (45 - 49)
	Half throttle	188 - 196 (117 - 122)	136 - 144 (85 - 90)
3.357	Closed throttle	65 - 73 (41 - 46)	62 - 70 (39 - 44)
	Half throttle	168 - 176 (105 - 110)	118 - 126 (74 - 79)

- At closed throttle, the accelerator opening is less than 1/8 condition.
- At half throttle, the accelerator opening is 4/8 of the full opening.

Vehicle Speed When Performing and Releasing Slip Lock-up

ECS00AWU

Final gear ratio	Throttle position	Gear position	Vehicle speed km/h (MPH)	
			Slip lock-up "ON"	Slip lock-up "OFF"
2.937	Closed throttle	4th	52 - 60 (33 - 38)	49 - 57 (31 - 36)
		5th	52 - 60 (33 - 38)	49 - 57 (31 - 36)
3.357	Closed throttle	4th	46 - 54 (29 - 34)	43 - 51 (27 - 32)
		5th	46 - 54 (29 - 34)	43 - 51 (27 - 32)

- At closed throttle, the accelerator opening is less than 1/8 condition.

TROUBLE DIAGNOSIS

ECS00AWV

Symptom Chart

- The diagnostics item numbers show the sequence for inspection. Inspect in order from item 1.
- Overhaul and inspect inside the A/T only if A/T fluid condition is NG. Refer to [AT-52, "Fluid Condition Check"](#).

No.	Items	Symptom	Condition	Diagnostic Item	Reference page
1		Large shock. ("N" → "D" position) Refer to AT-189, "Large Shock ("N" to "D" Position)" .	ON vehicle	1. Engine idle speed	EC-76
				2. Engine speed signal	AT-114
				3. Accelerator pedal position sensor	AT-124
				4. Control cable adjustment	AT-238
				5. ATF temperature sensor	AT-127
				6. ATF pressure switch 1 and front brake solenoid valve	AT-166, AT-145
				7. CAN communication line	AT-97
				8. Fluid level and state	AT-52
				9. Line pressure test	AT-53
				10. Control valve with TCM	AT-250
			OFF vehicle	11. Forward brake (Parts behind drum support is impossible to perform inspection by disassembly. Refer to AT-15 , AT-16 .)	AT-283
2	Shift Shock	Shock is too large when changing D1 → D2, 11 → 22 or M1 → M2.	ON vehicle	1. Accelerator pedal position sensor	AT-124
				2. Control cable adjustment	AT-238
				3. ATF pressure switch 5 and direct clutch solenoid valve	AT-170, AT-149
				4. CAN communication line	AT-97
				5. Engine speed signal	AT-114
				6. Turbine revolution sensor	AT-132
				7. Vehicle speed sensor A/T and vehicle speed sensor MTR	AT-109, AT-134
				8. Fluid level and state	AT-52
				9. Control valve with TCM	AT-250
			OFF vehicle	10. Direct clutch	AT-317
3		Shock is too large when changing D2 → D3, 22 → 33 or M2 → M3.	ON vehicle	1. Accelerator pedal position sensor	AT-124
				2. Control cable adjustment	AT-238
				3. ATF pressure switch 6, high and low reverse clutch solenoid valve	AT-172, AT-153
				4. CAN communication line	AT-97
				5. Engine speed signal	AT-114
				6. Turbine revolution sensor	AT-132
				7. Vehicle speed sensor A/T and vehicle speed sensor MTR	AT-109, AT-134
				8. Fluid level and state	AT-52
				9. Control valve with TCM	AT-250
			OFF vehicle	10. High and low reverse clutch	AT-315

TROUBLE DIAGNOSIS

No.	Items	Symptom	Condition	Diagnostic Item	Reference page	
4		Shock is too large when changing D3 → D4 , 3 ₃ → 4 ₄ or M3 → M4 .	ON vehicle	1. Accelerator pedal position sensor	AT-124	
				2. Control cable adjustment	AT-238	
				3. ATF pressure switch 3 and input clutch solenoid valve	AT-168, AT-141	
				4. CAN communication line	AT-97	
				5. Engine speed signal	AT-114	
				6. Turbine revolution sensor	AT-132	
				7. Vehicle speed sensor A/T and vehicle speed sensor MTR	AT-109, AT-134	
				8. Fluid level and state	AT-52	
				9. Control valve with TCM	AT-250	
			OFF vehicle	10. Input clutch	AT-305	
5	Shift Shock	Shock is too large when changing D4 → D5 , 4 ₄ → D5 or M4 → M5 .	ON vehicle	1. Accelerator pedal position sensor	AT-124	
				2. Control cable adjustment	AT-238	
				3. ATF pressure switch 1 and front brake solenoid valve	AT-166, AT-145	
				4. CAN communication line	AT-97	
				5. Engine speed signal	AT-114	
				6. Turbine revolution sensor	AT-132	
				7. Vehicle speed sensor A/T and vehicle speed sensor MTR	AT-109, AT-134	
				8. Fluid level and state	AT-52	
				9. Control valve with TCM	AT-250	
				OFF vehicle	10. Front brake (brake band)	AT-271
					11. Input clutch	AT-305
6		Shock is too large for downshift when accelerator pedal is pressed.	ON vehicle	1. Accelerator pedal position sensor	AT-124	
				2. Control cable adjustment	AT-238	
				3. CAN communication line	AT-97	
				4. Engine speed signal	AT-114	
				5. Turbine revolution sensor	AT-132	
				6. Vehicle speed sensor A/T and vehicle speed sensor MTR	AT-109, AT-134	
				7. Fluid level and state	AT-52	
				8. Control valve with TCM	AT-250	
				OFF vehicle	9. Front brake (brake band)	AT-271
					10. Input clutch	AT-305
					11. High and low reverse clutch	AT-315
					12. Direct clutch	AT-317

TROUBLE DIAGNOSIS

No.	Items	Symptom	Condition	Diagnostic Item	Reference page	
7		Shock is too large for upshift when accelerator pedal is released.	ON vehicle	1. Accelerator pedal position sensor	AT-124	A
				2. Control cable adjustment	AT-238	B
				3. Engine speed signal	AT-114	
				4. CAN communication line	AT-97	
				5. Turbine revolution sensor	AT-132	AT
				6. Vehicle speed sensor A/T and vehicle speed sensor MTR	AT-109, AT-134	
				7. Fluid level and state	AT-52	D
				8. Control valve with TCM	AT-250	
			OFF vehicle	9. Front brake (brake band)	AT-271	
				10. Input clutch	AT-305	E
				11. High and low reverse clutch	AT-315	
				12. Direct clutch	AT-317	F
8	Shift Shock	Shock is too large for lock-up.	ON vehicle	1. Accelerator pedal position sensor	AT-124	
				2. Control cable adjustment	AT-238	G
				3. Engine speed signal	AT-114	
				4. CAN communication line	AT-97	
				5. Turbine revolution sensor	AT-132	H
				6. Vehicle speed sensor A/T and vehicle speed sensor MTR	AT-109, AT-134	
				7. Torque converter clutch solenoid valve	AT-116	I
				8. Fluid level and state	AT-52	
				9. Control valve with TCM	AT-250	J
			OFF vehicle	10. Torque converter	AT-283	
9		Shock is too large during engine brake.	ON vehicle	1. Accelerator pedal position sensor	AT-124	
				2. Control cable adjustment	AT-238	K
				3. CAN communication line	AT-97	
				4. Fluid level and state	AT-52	
				5. Control valve with TCM	AT-250	L
			OFF vehicle	6. Front brake (brake band)	AT-271	
				7. Input clutch	AT-305	M
				8. High and low reverse clutch	AT-315	
				9. Direct clutch	AT-317	

TROUBLE DIAGNOSIS

No.	Items	Symptom	Condition	Diagnostic Item	Reference page			
10		Gear does not change from D1 → D2 . Refer to AT-200, "A/T Does Not Shift: D1 → D2" .	ON vehicle	1. Fluid level and state	AT-52			
				2. Vehicle speed sensor A/T and vehicle speed sensor MTR	AT-109, AT-134			
				3. ATF pressure switch 5 and direct clutch solenoid valve	AT-170, AT-149			
				4. Line pressure test	AT-53			
				5. CAN communication line	AT-97			
				6. Control valve with TCM	AT-250			
			OFF vehicle	7. Direct clutch	AT-317			
11		Gear does not change from D2 → D3 . Refer to AT-202, "A/T Does Not Shift: D2 → D3" .	ON vehicle	1. Fluid level and state	AT-52			
				2. Vehicle speed sensor A/T and vehicle speed sensor MTR	AT-109, AT-134			
				3. ATF pressure switch 6, high and low reverse clutch solenoid valve	AT-172, AT-153			
				4. Line pressure test	AT-53			
				5. CAN communication line	AT-97			
				6. Control valve with TCM	AT-250			
			OFF vehicle	7. High and low reverse clutch	AT-315			
12	No Up Shift	Gear does not change from D3 → D4 . Refer to AT-204, "A/T Does Not Shift: D3 → D4" .	ON vehicle	1. Fluid level and state	AT-52			
				2. Vehicle speed sensor A/T and vehicle speed sensor MTR	AT-109, AT-134			
				3. ATF pressure switch 3 and input clutch solenoid valve	AT-168, AT-141			
				4. ATF pressure switch 1 and front brake solenoid valve	AT-166, AT-145			
				5. Line pressure test	AT-53			
				6. CAN communication line	AT-97			
				7. Control valve with TCM	AT-250			
			OFF vehicle	8. Input clutch	AT-305			
13		Gear does not change from D4 → D5 . Refer to AT-207, "A/T Does Not Shift: D4 → D5" .	ON vehicle	1. Fluid level and state	AT-52			
				2. Vehicle speed sensor A/T and vehicle speed sensor MTR	AT-109, AT-134			
				3. ATF pressure switch 1 and front brake solenoid valve	AT-166, AT-145			
				4. ATF pressure switch 5 and direct clutch solenoid valve	AT-170, AT-149			
				5. Turbine revolution sensor	AT-132			
				6. Line pressure test	AT-53			
				7. CAN communication line	AT-97			
				8. Control valve with TCM	AT-250			
						OFF vehicle	9. Front brake (brake band)	AT-283
							10. Input clutch	AT-305

TROUBLE DIAGNOSIS

No.	Items	Symptom	Condition	Diagnostic Item	Reference page			
14		In D, 4 or M range, does not downshift to 4th gear. Refer to AT-215, "A/T Does Not Shift: 5th gear → 4th gear (Floor Shift Models)" .	ON vehicle	1. Fluid level and state	AT-52			
				2. Vehicle speed sensor A/T and vehicle speed sensor MTR	AT-109, AT-134			
				3. ATF pressure switch 1 and front brake solenoid valve	AT-166, AT-145			
				4. ATF pressure switch 5 and direct clutch solenoid valve	AT-170, AT-149			
				5. CAN communication line	AT-97			
				6. Line pressure test	AT-53			
				7. Control valve with TCM	AT-250			
			OFF vehicle	8. Front brake (brake band)	AT-283			
			9. Input clutch	AT-305				
15	No Down Shift	In D, 3 or M range, does not downshift to 3rd gear. Refer to AT-220, "A/T Does Not Shift: 4th gear → 3rd gear (Floor Shift Models)" .	ON vehicle	1. Fluid level and state	AT-52			
				2. Vehicle speed sensor A/T and vehicle speed sensor MTR	AT-109, AT-134			
				3. ATF pressure switch 3 and input clutch solenoid valve	AT-168, AT-141			
				4. ATF pressure switch 1 and front brake solenoid valve	AT-166, AT-145			
				5. CAN communication line	AT-97			
				6. Line pressure test	AT-53			
				7. Control valve with TCM	AT-250			
			OFF vehicle	8. Input clutch	AT-305			
			16	No Down Shift	In D, 2 or M range, does not downshift to 2nd gear. Refer to AT-224, "A/T Does Not Shift: 3rd gear → 2nd gear (Floor Shift Models)" .	ON vehicle	1. Fluid level and state	AT-52
2. Vehicle speed sensor A/T and vehicle speed sensor MTR	AT-109, AT-134							
3. ATF pressure switch 6, high and low reverse clutch solenoid valve	AT-172, AT-153							
4. CAN communication line	AT-97							
5. Line pressure test	AT-53							
6. Control valve with TCM	AT-250							
OFF vehicle	7. High and low reverse clutch	AT-315						
17	No Down Shift	In D, 1 or M range, does not downshift to 1st gear. Refer to AT-228, "A/T Does Not Shift: 2nd gear → 1st gear (Floor Shift Models)" .				ON vehicle	1. Fluid level and state	AT-52
							2. Vehicle speed sensor A/T and vehicle speed sensor MTR	AT-109, AT-134
			3. ATF pressure switch 5 and direct clutch solenoid valve	AT-170, AT-149				
			4. CAN communication line	AT-97				
			5. Line pressure test	AT-53				
			6. Control valve with TCM	AT-250				
			OFF vehicle	7. Direct clutch	AT-317			

A
B
AT
D
E
F
G
H
I
J
K
L
M

TROUBLE DIAGNOSIS

No.	Items	Symptom	Condition	Diagnostic Item	Reference page
18	Slips/Will Not engage	When D or M position, remains in 1st gear.	ON vehicle	1. Fluid level and state	AT-52
				2. Vehicle speed sensor A/T and vehicle speed sensor MTR	AT-109 , AT-134
				3. Direct clutch solenoid valve	AT-149
				4. Line pressure test	AT-53
				5. CAN communication line	AT-97
				6. Control valve with TCM	AT-250
			OFF vehicle	7. 3rd one-way clutch	AT-302
				8. 1st one-way clutch	AT-310
				9. Gear system	AT-271
				10. Reverse brake	AT-283
				11. Forward one-way clutch (Parts behind drum support is impossible to perform inspection by disassembly. Refer to AT-15 , AT-16 .)	AT-283
				12. Forward brake (Parts behind drum support is impossible to perform inspection by disassembly. Refer to AT-15 , AT-16 .)	AT-283
19		When D or M position, remains in 2nd gear.	ON vehicle	1. Fluid level and state	AT-52
				2. Vehicle speed sensor A/T and vehicle speed sensor MTR	AT-109 , AT-134
				3. Low coast brake solenoid valve	AT-157
				4. Line pressure test	AT-53
				5. CAN communication line	AT-97
				6. Control valve with TCM	AT-250
			OFF vehicle	7. 3rd one-way clutch	AT-302
				8. Gear system	AT-271
				9. Direct clutch	AT-317
				10. Forward brake (Parts behind drum support is impossible to perform inspection by disassembly. Refer to AT-15 , AT-16 .)	AT-283

TROUBLE DIAGNOSIS

No.	Items	Symptom	Condition	Diagnostic Item	Reference page	
20		When D or M position, remains in 3rd gear.	ON vehicle	1. Fluid level and state	AT-52	A
				2. Vehicle speed sensor A/T and vehicle speed sensor MTR	AT-109, AT-134	B
				3. Line pressure test	AT-53	AT
				4. CAN communication line	AT-97	
				5. Control valve with TCM	AT-250	
			OFF vehicle	6. 3rd one-way clutch	AT-302	D
				7. Gear system	AT-271	E
				8. High and low reverse clutch	AT-315	
				9. Forward one-way clutch (Parts behind drum support is impossible to perform inspection by disassembly. Refer to AT-15 , AT-16 .)	AT-283	F
				10. Forward brake (Parts behind drum support is impossible to perform inspection by disassembly. Refer to AT-15 , AT-16 .)	AT-283	
21	Slips/Will Not engage	When D or M position, remains in 4th gear.	ON vehicle	1. Fluid level and state	AT-52	G
				2. Vehicle speed sensor A/T and vehicle speed sensor MTR	AT-109, AT-134	H
				3. ATF pressure switch 3 and input clutch solenoid valve	AT-168, AT-141	
				4. ATF pressure switch 5 and direct clutch solenoid valve	AT-170, AT-149	I
				5. ATF pressure switch 6, high and low reverse clutch solenoid valve	AT-172, AT-153	J
				6. Low coast brake solenoid valve	AT-157	
				7. Front brake solenoid valve	AT-145	K
				8. Line pressure test	AT-53	
				9. CAN communication line	AT-97	
				10. Control valve with TCM	AT-250	
			OFF vehicle	11. Input clutch	AT-305	L
				12. Gear system	AT-271	
				13. High and low reverse clutch	AT-315	M
				14. Direct clutch	AT-317	

TROUBLE DIAGNOSIS

No.	Items	Symptom	Condition	Diagnostic Item	Reference page
22		When D or M position, remains in 5th gear.	ON vehicle	1. Fluid level and state	AT-52
				2. Vehicle speed sensor A/T and vehicle speed sensor MTR	AT-109 , AT-134
				3. ATF pressure switch 1 and front brake solenoid valve	AT-166 , AT-145
				4. Line pressure test	AT-53
				5. CAN communication line	AT-97
				6. Control valve with TCM	AT-250
			OFF vehicle	7. Front brake (brake band)	AT-283
				8. Input clutch	AT-305
				9. Gear system	AT-271
				10. High and low reverse clutch	AT-315
23	Slips/Will Not Engage	Vehicle cannot be started from D1 . Refer to AT-197 , " Vehicle Cannot Be Started From D1 ".	ON vehicle	1. Fluid level and state	AT-52
				2. Accelerator pedal position sensor	AT-124
				3. Line pressure test	AT-53
				4. CAN communication line	AT-97
				5. Control valve with TCM	AT-250
			OFF vehicle	6. Torque converter	AT-283
				7. Oil pump assembly	AT-300
				8. 3rd one-way clutch	AT-302
				9. 1st one-way clutch	AT-310
				10. Gear system	AT-271
				11. Reverse brake	AT-283
				12. Forward one-way clutch (Parts behind drum support is impossible to perform inspection by disassembly. Refer to AT-15 , AT-16 .)	AT-283
				13. Forward brake (Parts behind drum support is impossible to perform inspection by disassembly. Refer to AT-15 , AT-16 .)	AT-283
24		Does not lock-up. Refer to AT-209 , " A/T Does Not Perform Lock-up ".	ON vehicle	1. Fluid level and state	AT-52
				2. Line pressure test	AT-53
				3. Engine speed signal	AT-114
				4. Turbine revolution sensor	AT-132
				5. Torque converter clutch solenoid valve	AT-116
				6. CAN communication line	AT-97
				7. Control valve with TCM	AT-250
			OFF vehicle	8. Torque converter	AT-283
				9. Oil pump assembly	AT-300

TROUBLE DIAGNOSIS

No.	Items	Symptom	Condition	Diagnostic Item	Reference page	
25	Slips/Will Not engage	Does not hold lock-up condition. Refer to AT-211, "A/T Does Not Hold Lock-up Condition" .	ON vehicle	1. Fluid level and state	AT-52	
				2. Line pressure test	AT-53	
				3. Engine speed signal	AT-114	
				4. Turbine revolution sensor	AT-132	
				5. Torque converter clutch solenoid valve	AT-116	
				6. CAN communication line	AT-97	
				7. Control valve with TCM	AT-250	
			OFF vehicle	8. Torque converter	AT-283	
				9. Oil pump assembly	AT-300	
26		Slips/Will Not engage	Lock-up is not released. Refer to AT-213, "Lock-up Is Not Released" .	ON vehicle	1. Fluid level and state	AT-52
					2. Line pressure test	AT-53
					3. Engine speed signal	AT-114
					4. Turbine revolution sensor	AT-132
					5. Torque converter clutch solenoid valve	AT-116
					6. CAN communication line	AT-97
					7. Control valve with TCM	AT-250
				OFF vehicle	8. Torque converter	AT-283
					9. Oil pump assembly	AT-300
27	Slips/Will Not engage		No shock at all or the clutch slips when vehicle changes speed D1 → D2 , 11 → 22 or M1 → M2 .	ON vehicle	1. Fluid level and state	AT-52
					2. Vehicle speed sensor A/T and vehicle speed sensor MTR	AT-109, AT-134
					3. ATF pressure switch 5 and direct clutch solenoid valve	AT-170, AT-149
					4. CAN communication line	AT-97
					5. Line pressure test	AT-53
					6. Control valve with TCM	AT-250
				OFF vehicle	7. Torque converter	AT-283
					8. Oil pump assembly	AT-300
					9. 3rd one-way clutch	AT-302
		10. Gear system			AT-271	
		11. Direct clutch			AT-317	
		12. Forward brake (Parts behind drum support is impossible to perform inspection by disassembly. Refer to AT-15 , AT-16 .)			AT-283	

A
B
AT
D
E
F
G
H
I
J
K
L
M

TROUBLE DIAGNOSIS

No.	Items	Symptom	Condition	Diagnostic Item	Reference page
28	Slips/Will Not engage	No shock at all or the clutch slips when vehicle changes speed D2 → D3 , 22 → 33 or M2 → M3 .	ON vehicle	1. Fluid level and state	AT-52
				2. Vehicle speed sensor A/T and vehicle speed sensor MTR	AT-109 , AT-134
				3. ATF pressure switch 6, high and low reverse clutch solenoid valve	AT-172 , AT-153
				4. CAN communication line	AT-97
				5. Line pressure test	AT-53
				6. Control valve with TCM	AT-250
			OFF vehicle	7. Torque converter	AT-283
				8. Oil pump assembly	AT-300
				9. 3rd one-way clutch	AT-302
				10. Gear system	AT-271
				11. High and low reverse clutch	AT-315
				12. Forward one- way clutch (Parts behind drum support is impossible to perform inspection by disassembly. Refer to AT-15 , AT-16 .)	AT-283
				13. Forward brake (Parts behind drum support is impossible to perform inspection by disassembly. Refer to AT-15 , AT-16 .)	AT-283
29	Slips/Will Not engage	No shock at all or the clutch slips when vehicle changes speed D3 → D4 , 33 → 44 or M3 → M4 .	ON vehicle	1. Fluid level and state	AT-52
				2. Vehicle speed sensor A/T and vehicle speed sensor MTR	AT-109 , AT-134
				3. ATF pressure switch 3 and input clutch solenoid valve	AT-168 , AT-141
				4. ATF pressure switch 1 and front brake solenoid valve	AT-166 , AT-145
				5. CAN communication line	AT-97
				6. Line pressure test	AT-53
				7. Control valve with TCM	AT-250
			OFF vehicle	8. Torque converter	AT-283
				9. Oil pump assembly	AT-300
				10. Input clutch	AT-305
				11. Gear system	AT-271
				12. High and low reverse clutch	AT-315
				13. Direct clutch	AT-317

TROUBLE DIAGNOSIS

No.	Items	Symptom	Condition	Diagnostic Item	Reference page	
30	Slips/Will Not engage	No shock at all or the clutch slips when vehicle changes speed D4 → D5 , 44 → D5 or M4 → M5 .	ON vehicle	1. Fluid level and state	AT-52	A
				2. Vehicle speed sensor A/T and vehicle speed sensor MTR	AT-109, AT-134	B
				3. ATF pressure switch 1 and front brake solenoid valve	AT-166, AT-145	AT
				4. ATF pressure switch 5 and direct clutch solenoid valve	AT-170, AT-149	
				5. CAN communication line	AT-97	D
				6. Line pressure test	AT-53	
				7. Control valve with TCM	AT-250	
			OFF vehicle	8. Torque converter	AT-283	E
				9. Oil pump assembly	AT-300	
				10. Front brake (brake band)	AT-283	F
				11. Input clutch	AT-305	
				12. Gear system	AT-271	G
				13. High and low reverse clutch	AT-315	
31	Slips/Will Not engage	When you press the accelerator pedal and shift speed D5 → D4 , D5 → 44 or M5 →M4 the engine idles or the transmission slips.	ON vehicle	1. Fluid level and state	AT-52	H
				2. Vehicle speed sensor A/T and vehicle speed sensor MTR	AT-109, AT-134	
				3. ATF pressure switch 1 and front brake solenoid valve	AT-166, AT-145	I
				4. ATF pressure switch 5 and direct clutch solenoid valve	AT-170, AT-149	
				5. CAN communication line	AT-97	J
				6. Line pressure test	AT-53	
				7. Control valve with TCM	AT-250	
			OFF vehicle	8. Torque converter	AT-283	K
				9. Oil pump assembly	AT-300	
				10. Input clutch	AT-305	L
				11. Gear system	AT-271	
				12. High and low reverse clutch	AT-315	M
				13. Direct clutch	AT-317	

TROUBLE DIAGNOSIS

No.	Items	Symptom	Condition	Diagnostic Item	Reference page
32	Slips/Will Not engage	When you press the accelerator pedal and shift speed D4 → D3 , 44 → 33 or M4 →M3 the engine idles or the transmission slips.	ON vehicle	1. Fluid level and state	AT-52
				2. Vehicle speed sensor A/T and vehicle speed sensor MTR	AT-109, AT-134
				3. ATF pressure switch 3 and input clutch solenoid valve	AT-168, AT-141
				4. ATF pressure switch 1 and front brake solenoid valve	AT-166, AT-145
				5. CAN communication line	AT-97
				6. Line pressure test	AT-53
				7. Control valve with TCM	AT-250
			OFF vehicle	8. Torque converter	AT-283
				9. Oil pump assembly	AT-300
				10. 3rd one-way clutch	AT-302
				11. Gear system	AT-271
				12. High and low reverse clutch	AT-315
				13. Forward one- way clutch (Parts behind drum support is impossible to perform inspection by disassembly. Refer to AT-15 , AT-16 .)	AT-283
				14. Forward brake (Parts behind drum support is impossible to perform inspection by disassembly. Refer to AT-15 , AT-16 .)	AT-283
33	Slips/Will Not engage	When you press the accelerator pedal and shift speed D3 → D2 , 33 → 22 or M3 →M2 the engine idles or the transmission slips.	ON vehicle	1. Fluid level and state	AT-52
				2. Vehicle speed sensor A/T and vehicle speed sensor MTR	AT-109, AT-134
				3. ATF pressure switch 6, high and low reverse clutch solenoid valve	AT-172, AT-153
				4. ATF pressure switch 5 and direct clutch solenoid valve	AT-170, AT-149
				5. CAN communication line	AT-97
				6. Line pressure test	AT-53
				7. Control valve with TCM	AT-250
			OFF vehicle	8. Torque converter	AT-283
				9. Oil pump assembly	AT-300
				10. 3rd one-way clutch	AT-302
				11. Gear system	AT-271
				12. Direct clutch	AT-317
				13. Forward brake (Parts behind drum support is impossible to perform inspection by disassembly. Refer to AT-15 , AT-16 .)	AT-283

TROUBLE DIAGNOSIS

No.	Items	Symptom	Condition	Diagnostic Item	Reference page
34	Slips/Will Not Engage	When you press the accelerator pedal and shift speed D2 → D1 , 22 → 11 or M2 →M1 the engine idles or the transmission slips.	ON vehicle	1. Fluid level and state	AT-52
				2. Vehicle speed sensor A/T and vehicle speed sensor MTR	AT-109 , AT-134
				3. ATF pressure switch 5 and direct clutch solenoid valve	AT-170 , AT-149
				4. CAN communication line	AT-97
				5. Line pressure test	AT-53
				6. Control valve with TCM	AT-250
			OFF vehicle	7. Torque converter	AT-283
				8. Oil pump assembly	AT-300
				9. 3rd one-way clutch	AT-302
				10. 1st one-way clutch	AT-310
				11. Gear system	AT-271
				12. Reverse brake	AT-283
				13. Forward one- way clutch (Parts behind drum support is impossible to perform inspection by disassembly. Refer to AT-15 , AT-16 .)	AT-283
				14. Forward brake (Parts behind drum support is impossible to perform inspection by disassembly. Refer to AT-15 , AT-16 .)	AT-283
35	With selector lever in D position, acceleration is extremely poor.		ON vehicle	1. Fluid level and state	AT-52
				2. Line pressure test	AT-53
				3. Accelerator pedal position sensor	AT-124
				4. CAN communication line	AT-97
				5. PNP switch	AT-105
				6. Control cable adjustment	AT-238
				7. Control valve with TCM	AT-250
			OFF vehicle	8. Torque converter	AT-283
				9. Oil pump assembly	AT-300
				10. 1st one-way clutch	AT-310
				11. Gear system	AT-271
				12. Reverse brake	AT-283
				13. Forward one- way clutch (Parts behind drum support is impossible to perform inspection by disassembly. Refer to AT-15 , AT-16 .)	AT-283
				14. Forward brake (Parts behind drum support is impossible to perform inspection by disassembly. Refer to AT-15 , AT-16 .)	AT-283

A
B
AT
D
E
F
G
H
I
J
K
L
M

TROUBLE DIAGNOSIS

No.	Items	Symptom	Condition	Diagnostic Item	Reference page
36		With selector lever in R position, acceleration is extremely poor.	ON vehicle	1. Fluid level and state	AT-52
				2. Line pressure test	AT-53
				3. Accelerator pedal position sensor	AT-124
				4. ATF pressure switch 6, high and low reverse clutch solenoid valve	AT-172 , AT-153
				5. CAN communication line	AT-97
				6. PNP switch	AT-105
				7. Control cable adjustment	AT-238
				8. Control valve with TCM	AT-250
			OFF vehicle	9. Gear system	AT-271
				10. Output shaft	AT-283
				11. Reverse brake	AT-283
37	Slips/Will Not Engage	While starting off by accelerating in 1st, engine races or slippage occurs.	ON vehicle	1. Fluid level and state	AT-52
				2. Line pressure test	AT-53
				3. Accelerator pedal position sensor	AT-124
				4. CAN communication line	AT-97
				5. Control valve with TCM	AT-250
			OFF vehicle	6. Torque converter	AT-283
				7. Oil pump assembly	AT-300
				8. 3rd one-way clutch	AT-302
				9. 1st one-way clutch	AT-310
				10. Gear system	AT-271
				11. Reverse brake	AT-283
				12. Forward one-way clutch (Parts behind drum support is impossible to perform inspection by disassembly. Refer to AT-15 , AT-16 .)	AT-283
				13. Forward brake (Parts behind drum support is impossible to perform inspection by disassembly. Refer to AT-15 , AT-16 .)	AT-283
38		While accelerating in 2nd, engine races or slippage occurs.	ON vehicle	1. Fluid level and state	AT-52
				2. Line pressure test	AT-53
				3. Accelerator pedal position sensor	AT-124
				4. CAN communication line	AT-97
				5. ATF pressure switch 5 and direct clutch solenoid valve	AT-170 , AT-149
				6. Control valve with TCM	AT-250
			OFF vehicle	7. Torque converter	AT-283
				8. Oil pump assembly	AT-300
				9. 3rd one-way clutch	AT-302
				10. Gear system	AT-271
				11. Direct clutch	AT-317
				12. Forward brake (Parts behind drum support is impossible to perform inspection by disassembly. Refer to AT-15 , AT-16 .)	AT-283

TROUBLE DIAGNOSIS

No.	Items	Symptom	Condition	Diagnostic Item	Reference page
39	Slips/Will Not Engage	While accelerating in 3rd, engine races or slippage occurs.	ON vehicle	1. Fluid level and state	AT-52
				2. Line pressure test	AT-53
				3. Accelerator pedal position sensor	AT-124
				4. CAN communication line	AT-97
				5. ATF pressure switch 6, high and low reverse clutch solenoid valve	AT-172 , AT-153
				6. Control valve with TCM	AT-250
			OFF vehicle	7. Torque converter	AT-283
				8. Oil pump assembly	AT-300
				9. 3rd one-way clutch	AT-302
				10. Gear system	AT-271
				11. High and low reverse clutch	AT-315
				12. Forward one- way clutch (Parts behind drum support is impossible to perform inspection by disassembly. Refer to AT-15 , AT-16 .)	AT-283
				13. Forward brake (Parts behind drum support is impossible to perform inspection by disassembly. Refer to AT-15 , AT-16 .)	AT-283
40		While accelerating in 4th, engine races or slippage occurs.	ON vehicle	1. Fluid level and state	AT-52
				2. Line pressure test	AT-53
				3. Accelerator pedal position sensor	AT-124
				4. CAN communication line	AT-97
				5. ATF pressure switch 3 and input clutch solenoid valve	AT-168 , AT-141
				6. Control valve with TCM	AT-250
			OFF vehicle	7. Torque converter	AT-283
				8. Oil pump assembly	AT-300
				9. Input clutch	AT-305
				10. Gear system	AT-271
				11. High and low reverse clutch	AT-315
				12. Direct clutch	AT-317

TROUBLE DIAGNOSIS

No.	Items	Symptom	Condition	Diagnostic Item	Reference page				
41		While accelerating in 5th, engine races or slippage occurs.	ON vehicle	1. Fluid level and state	AT-52				
				2. Line pressure test	AT-53				
				3. Accelerator pedal position sensor	AT-124				
				4. CAN communication line	AT-97				
				5. ATF pressure switch 1 and front brake solenoid valve	AT-166 , AT-145				
				6. Control valve with TCM	AT-250				
			OFF vehicle	7. Torque converter	AT-283				
				8. Oil pump assembly	AT-300				
				9. Front brake (brake band)	AT-283				
				10. Input clutch	AT-305				
				11. Gear system	AT-271				
				12. High and low reverse clutch	AT-315				
42	Slips/Will Not Engage	Slips at lock-up.	ON vehicle	1. Fluid level and state	AT-52				
				2. Line pressure test	AT-53				
				3. Engine speed signal	AT-114				
				4. Turbine revolution sensor	AT-132				
				5. Torque converter clutch solenoid valve	AT-116				
				6. CAN communication line	AT-97				
				7. Control valve with TCM	AT-250				
			OFF vehicle	8. Torque converter	AT-283				
				9. Oil pump assembly	AT-300				
				43		No creep at all. Refer to AT-192 , "Vehicle Does Not Creep Backward In "R" Position", AT-195 , "Vehicle Does Not Creep Forward In "D" Position"	ON vehicle	1. Fluid level and state	AT-52
								2. Line pressure test	AT-53
								3. Accelerator pedal position sensor	AT-124
4. ATF pressure switch 5 and direct clutch solenoid valve	AT-170 , AT-149								
5. PNP switch	AT-105								
6. CAN communication line	AT-97								
7. Control cable adjustment	AT-238								
8. Control valve with TCM	AT-250								
OFF vehicle	9. Torque converter	AT-283							
	10. Oil pump assembly	AT-300							
	11. 1st one-way clutch	AT-310							
	12. Gear system	AT-271							
	13. Reverse brake	AT-283							
	14. Direct clutch	AT-317							
	15. Forward one- way clutch (Parts behind drum support is impossible to perform inspection by disassembly. Refer to AT-15 , AT-16 .)	AT-283							
	16. Forward brake (Parts behind drum support is impossible to perform inspection by disassembly. Refer to AT-15 , AT-16 .)	AT-283							

TROUBLE DIAGNOSIS

No.	Items	Symptom	Condition	Diagnostic Item	Reference page
44		Vehicle cannot run in all positions.	ON vehicle	1. Fluid level and state	AT-52
				2. Line pressure test	AT-53
				3. PNP switch	AT-105
				4. Control cable adjustment	AT-238
				5. Control valve with TCM	AT-250
			OFF vehicle	6. Oil pump assembly	AT-300
				7. Gear system	AT-271
				8. Output shaft	AT-283
45	Slips/Will Not Engage	With selector lever in D position, driving is not possible.	ON vehicle	1. Fluid level and state	AT-52
				2. Line pressure test	AT-53
				3. PNP switch	AT-105
				4. Control cable adjustment	AT-238
				5. Control valve with TCM	AT-250
			OFF vehicle	6. Torque converter	AT-283
				7. Oil pump assembly	AT-300
				8. 1st one-way clutch	AT-310
				9. Gear system	AT-271
				10. Reverse brake	AT-283
				11. Forward one- way clutch (Parts behind drum support is impossible to perform inspection by disassembly. Refer to AT-15 , AT-16 .)	AT-283
				12. Forward brake (Parts behind drum support is impossible to perform inspection by disassembly. Refer to AT-15 , AT-16 .)	AT-283
46		With selector lever in R position, driving is not possible.	ON vehicle	1. Fluid level and state	AT-52
				2. Line pressure test	AT-53
				3. PNP switch	AT-105
				4. Control cable adjustment	AT-238
				5. Control valve with TCM	AT-250
			OFF vehicle	6. Gear system	AT-271
				7. Output shaft	AT-283
				8. Reverse brake	AT-283
47	Others	Shift point is high in D position.	ON vehicle	1. Vehicle speed sensor A/T and vehicle speed sensor MTR	AT-109 , AT-134
				2. Accelerator pedal position sensor	AT-124
				3. CAN communication line	AT-97
				4. ATF temperature sensor	AT-127
				5. Control valve with TCM	AT-250

A

B

AT

D

E

F

G

H

I

J

K

L

M

TROUBLE DIAGNOSIS

No.	Items	Symptom	Condition	Diagnostic Item	Reference page
48	Others	Shift point is low in D position.	ON vehicle	1. Vehicle speed sensor A/T and vehicle speed sensor MTR	AT-109 , AT-134
				2. Accelerator pedal position sensor	AT-124
				3. CAN communication line	AT-97
				4. Control valve with TCM	AT-250
49		Judder occurs during lock-up.	ON vehicle	1. Fluid level and state	AT-52
				2. Engine speed signal	AT-114
				3. Turbine revolution sensor	AT-132
				4. Vehicle speed sensor A/T and vehicle speed sensor MTR	AT-109 , AT-134
				5. Accelerator pedal position sensor	AT-124
				6. CAN communication line	AT-97
				7. Torque converter clutch solenoid valve	AT-116
				8. Control valve with TCM	AT-250
		OFF vehicle	9. Torque converter	AT-283	
50	Strange noise in "R" position.	ON vehicle	1. Fluid level and state	AT-52	
			2. Engine speed signal	AT-114	
			3. CAN communication line	AT-97	
			4. Control valve with TCM	AT-250	
		OFF vehicle	5. Torque converter	AT-283	
			6. Oil pump assembly	AT-300	
			7. Gear system	AT-271	
			8. High and low reverse clutch	AT-315	
			9. Reverse brake	AT-283	
51	Strange noise in "N" position.	ON vehicle	1. Fluid level and state	AT-52	
			2. Engine speed signal	AT-114	
			3. CAN communication line	AT-97	
			4. Control valve with TCM	AT-250	
		OFF vehicle	5. Torque converter	AT-283	
			6. Oil pump assembly	AT-300	
			7. Gear system	AT-271	
52	Strange noise in "D" position.	ON vehicle	1. Fluid level and state	AT-52	
			2. Engine speed signal	AT-114	
			3. CAN communication line	AT-97	
			4. Control valve with TCM	AT-250	
		OFF vehicle	5. Torque converter	AT-283	
			6. Oil pump assembly	AT-300	
			7. Gear system	AT-271	
			8. Forward brake (Parts behind drum support is impossible to perform inspection by disassembly. Refer to AT-15 , AT-16 .)	AT-283	

TROUBLE DIAGNOSIS

No.	Items	Symptom	Condition	Diagnostic Item	Reference page
53		Vehicle dose not decelerate by engine brake. Refer to AT-233 . "Vehicle Does Not Decelerate By Engine Brake" .	ON vehicle	1. PNP switch	AT-105
				2. Fluid level and state	AT-52
				3. Control cable adjustment	AT-238
				4. 1st position switch	AT-233
				5. ATF pressure switch 5	AT-170
				6. CAN communication line	AT-97
				7. Control valve with TCM	AT-250
			OFF vehicle	8. Input clutch	AT-305
				9. High and low reverse clutch	AT-315
				10. Direct clutch	AT-317
54	Others	Engine brake does not operate in "2" position.	ON vehicle	1. PNP switch	AT-105
				2. Fluid level and state	AT-52
				3. Control cable adjustment	AT-238
				5. ATF pressure switch 6	AT-172
				6. CAN communication line	AT-97
				7. Control valve with TCM	AT-250
				OFF vehicle	8. Front brake (brake band)
			9. Input clutch		AT-305
			10. High and low reverse clutch		AT-315
			55		Engine brake does not operate in "1" position.
2. Fluid level and state	AT-52				
3. Control cable adjustment	AT-238				
4. 1st position switch	AT-233				
5. ATF pressure switch 5	AT-170				
6. CAN communication line	AT-97				
7. Control valve with TCM	AT-250				
OFF vehicle	8. Input clutch	AT-305			
	9. High and low reverse clutch	AT-315			
	10. Direct clutch	AT-317			

A
B
AT
D
E
F
G
H
I
J
K
L
M

TROUBLE DIAGNOSIS

No.	Items	Symptom	Condition	Diagnostic Item	Reference page
56		Maximum speed low.	ON vehicle	1. Fluid level and state	AT-52
				2. Line pressure test	AT-53
				3. Accelerator pedal position sensor	AT-124
				4. CAN communication line	AT-97
				5. Direct clutch solenoid valve	AT-149
				6. Control valve with TCM	AT-250
			OFF vehicle	7. Torque converter	AT-283
				8. Oil pump assembly	AT-300
				9. Input clutch	AT-305
				10. Gear system	AT-271
				11. High and low reverse clutch	AT-315
				12. Direct clutch	AT-317
				13. Forward one- way clutch (Parts behind drum support is impossible to perform inspection by disassembly. Refer to AT-15 , AT-16 .)	AT-283
				14 Forward brake (Parts behind drum support is impossible to perform inspection by disassembly. Refer to AT-15 , AT-16 .)	AT-283
57	Others	Extremely large creep.	ON vehicle	1. Engine idle speed	EC-76
				2. CAN communication line	AT-97
				3. ATF pressure switch 5	AT-170
			OFF vehicle	4. Torque converter	AT-283
58		With selector lever in P position, vehicle does not enter parking condition or, with selector lever in another position, parking condition is not cancelled. Refer to AT-187 , " In "P" Position, Vehicle Moves When Pushed ".	ON vehicle	1. PNP switch	AT-105
				2. Control cable adjustment	AT-238
			OFF vehicle	3. Parking pawl components	AT-271
59		Vehicle runs with transmission in " P" position.	ON vehicle	1. PNP switch	AT-105
				2. Fluid level and state	AT-52
				3. Control cable adjustment	AT-238
				4. Control valve with TCM	AT-250
				5. Parking pawl components	AT-271
			OFF vehicle	6. Gear system	AT-271

TROUBLE DIAGNOSIS

No.	Items	Symptom	Condition	Diagnostic Item	Reference page
60	Others	Vehicle runs with transmission in "N" position. Refer to AT-188, "In "N" Position, Vehicle Moves" .	ON vehicle	1. PNP switch	AT-105
				2. Fluid level and state	AT-52
				3. Control cable adjustment	AT-238
				4. Control valve with TCM	AT-250
			OFF vehicle	5. Input clutch	AT-305
				6. Gear system	AT-271
				7. Direct clutch	AT-317
				8. Reverse brake	AT-283
				9. Forward one- way clutch (Parts behind drum support is impossible to perform inspection by disassembly. Refer to AT-15 , AT-16 .)	AT-283
				10. Forward brake (Parts behind drum support is impossible to perform inspection by disassembly. Refer to AT-15 , AT-16 .)	AT-283
61	Others	Engine does not start in "N" or "P" position. Refer to AT-186, "Engine Cannot Be Started In "P" or "N" Position" .	ON vehicle	1. Ignition switch and starter	PG-4, SC-10
				2. Control cable adjustment	AT-238
				3. PNP switch	AT-105
62	Others	Engine starts in positions other than "N" or "P".	ON vehicle	1. Ignition switch and starter	PG-4, SC-10
				2. Control cable adjustment	AT-238
				3. PNP switch	AT-105
63	Others	Engine stall.	ON vehicle	1. Fluid level and state	AT-52
				2. Engine speed signal	AT-114
				3. Turbine revolution sensor	AT-132
				4. Torque converter clutch solenoid valve	AT-116
				5. CAN communication line	AT-97
				6. Control valve with TCM	AT-250
			OFF vehicle	7. Torque converter	AT-283
64	Others	Engine stalls when select lever shifted "N" → "D", "R".	ON vehicle	1. Fluid level and state	AT-52
				2. Engine speed signal	AT-114
				3. Turbine revolution sensor	AT-132
				4. Torque converter clutch solenoid valve	AT-116
				5. CAN communication line	AT-97
				6. Control valve with TCM	AT-250
			OFF vehicle	7. Torque converter	AT-283

A
B
AT
D
E
F
G
H
I
J
K
L
M

TROUBLE DIAGNOSIS

No.	Items	Symptom	Condition	Diagnostic Item	Reference page
65	Others	Engine speed does not return to idle. Refer to AT-214 , " Engine Speed Does Not Return To Idle ".	ON vehicle	1. Fluid level and state	AT-52
				2. ATF pressure switch 5 and direct clutch solenoid valve	AT-170 , AT-149
				3. ATF pressure switch 1 and front brake solenoid valve	AT-166 , AT-145
				4. Accelerator pedal position sensor	AT-124
				5. Vehicle speed sensor A/T and vehicle speed sensor MTR	AT-109 , AT-134
				6. CAN communication line	AT-97
				7. Control valve with TCM	AT-250
			OFF vehicle	8. Front brake (brake band)	AT-283
			9. Direct clutch	AT-317	

TCM Input/Output Signal Reference Values A/T ASSEMBLY HARNESS CONNECTOR TERMINAL LAYOUT

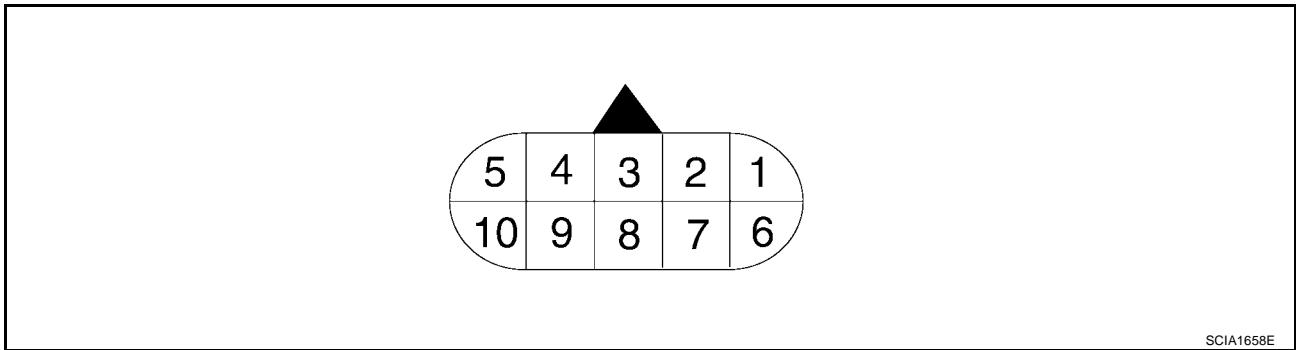

ECS00AWW



SCIA1658E

TCM INSPECTION TABLE

Data are reference value and are measured between each terminal and ground.

Terminal No.	Wire color	Item	Condition	Data (Approx.)	
1	P	Power supply (Memory back-up)	Always	Battery voltage	
2	P	Power supply (Memory back-up)	Always	Battery voltage	
3	L	CAN-H	-	-	
4	V	K-line (CONSULT-II signal)	The terminal is connected to the data link connector for CONSULT-II.		
5	B	Ground	Always	0V	
6	BR *1 Y/R *2	Power supply		-	Battery voltage
				-	0V
7	R	Back-up lamp relay		Selector lever in "R" position.	0V
				Selector lever in other positions.	Battery voltage
8	P	CAN-L	-	-	

TROUBLE DIAGNOSIS

Terminal No.	Wire color	Item	Condition	Data (Approx.)	
9	B/R	Starter relay		Selector lever in "N", "P" positions.	Battery voltage
				Selector lever in other positions.	0V
10	B	Ground	Always	0V	

*1: Column shift

*2: Floor shift

CONSULT-II FUNCTION (A/T)

ECS00CBV

CONSULT-II can display each diagnostic item using the diagnostic test modes shown following.

FUNCTION

TCM diagnostic mode	Description
WORK SUPPORT	Supports inspections and adjustments. Commands are transmitted to the TCM for setting the status suitable for required operation, input/output signals are received from the TCM and received data is displayed.
SELF-DIAG RESULTS	Displays TCM self-diagnosis results.
DATA MONITOR	Displays TCM input/output data in real time.
CAN DIAG SUPPORT MNTR	The result of transmit/receive diagnosis of CAN communication can be read.
ACTIVE TEST	Operation of electrical loads can be checked by sending drive signal to them.
FUNCTION TEST	Conducted by CONSULT-II instead of a technician to determine whether each system is "OK" or "NG".
ECU PART NUMBER	TCM part number can be read.

CONSULT-II REFERENCE VALUE

NOTICE:

- The CONSULT-II electrically displays shift timing and lock-up timing (that is, operation timing of each solenoid).
Check for time difference between actual shift timing and the CONSULT-II display. If the difference is noticeable, mechanical parts (except solenoids, sensors, etc.) may be malfunctioning. Check mechanical parts using applicable diagnostic procedures.
- Shift schedule (which implies gear position) displayed on CONSULT-II and that indicated in Service Manual may differ slightly. This occurs because of the following reasons:
 - Actual shift schedule has more or less tolerance or allowance,
 - Shift schedule indicated in Service Manual refers to the point where shifts start, and
 - Gear position displayed on CONSULT-II indicates the point where shifts are completed.
- Display of solenoid valves on CONSULT-II changes at the start of shifting, while gear position is displayed upon completion of shifting (which is computed by TCM).

Item name	Condition	Display value (Approx.)
ATF TEMP SE 1	0°C (32° F) - 20°C (68°F) - 80°C (176°F)	2.2 - 1.8 - 0.6 V
ATF TEMP SE 2		2.2 - 1.7 - 0.45 V
TCC SOLENOID	When perform slip lock-up	0.2 - 0.4 A
	When perform lock-up	0.4 - 0.6 A
SLCT LVR POSI	Selector lever in "N", "P" position.	N/P
	Selector lever in "R" position.	R
	Selector lever in "D" position.	D
	Selector lever in "4" position.	4
	Selector lever in "3" position.	3
	Selector lever in "2" position.	2
	Selector lever in "1" position.	1

TROUBLE DIAGNOSIS

Item name	Condition	Display value (Approx.)
VHCL/S SE·A/T	During driving	Approximately matches the speedometer reading.
ENGINE SPEED	Engine running	Closely matches the tachometer reading.
LINE PRES SOL	During driving	0.2 - 0.6 A
TURBINE REV	During driving (lock-up ON)	Approximately matches the engine speed.
VHCL/S SE·MTR	During driving	Approximately matches the speedometer reading.
ATF PRES SW 1	Front brake engaged. Refer to AT-18 , AT-20	ON
	Front brake disengaged. Refer to AT-18 , AT-20	OFF
ATF PRES SW 2	Low coast brake engaged. Refer to AT-18 , AT-20	ON
	Low coast brake disengaged. Refer to AT-18 , AT-20	OFF
ATF PRES SW 3	Input clutch engaged. Refer to AT-18 , AT-20	ON
	Input clutch disengaged. Refer to AT-18 , AT-20	OFF
ATF PRES SW 5	Direct clutch engaged. Refer to AT-18 , AT-20	ON
	Direct clutch disengaged. Refer to AT-18 , AT-20	OFF
ATF PRES SW 6	High and low reverse clutch engaged. Refer to AT-18 , AT-20	ON
	High and low reverse clutch disengaged. Refer to AT-18 , AT-20	OFF
I/C SOLENOID	Input clutch disengaged. Refer to AT-18 , AT-20	0.6 - 0.8 A
	Input clutch engaged. Refer to AT-18 , AT-20	0 - 0.05 A
FR/B SOLENOID	Front brake engaged. Refer to AT-18 , AT-20	0.6 - 0.8 A
	Front brake disengaged. Refer to AT-18 , AT-20	0 - 0.05 A
D/C SOLENOID	Direct clutch disengaged. Refer to AT-18 , AT-20	0.6 - 0.8 A
	Direct clutch engaged. Refer to AT-18 , AT-20	0 - 0.05 A
HLR/C SOL	High and low reverse clutch disengaged. Refer to AT-18 , AT-20	0.6 - 0.8 A
	High and low reverse clutch engaged. Refer to AT-18 , AT-20	0 - 0.05 A
ON OFF SOL	Low coast brake engaged. Refer to AT-18 , AT-20	ON
	Low coast brake disengaged. Refer to AT-18 , AT-20	OFF
STARTER RELAY	Selector lever in "N", "P" position.	ON
	Selector lever in other position.	OFF
ACCELE POSI	Released accelerator pedal.	0.0/8
	Fully depressed accelerator pedal.	8/8
THROTTLE POSI	Released accelerator pedal.	0.0/8
	Fully depressed accelerator pedal.	8/8
CLSD THL POS	Released accelerator pedal.	ON
	Fully depressed accelerator pedal.	OFF
W/O THL POS	Fully depressed accelerator pedal.	ON
	Released accelerator pedal.	OFF
BRAKE SW	Depressed brake pedal.	ON
	Released brake pedal.	OFF

TROUBLE DIAGNOSIS

CONSULT-II SETTING PROCEDURE

CAUTION:

If CONSULT-II is used with no connection of CONSULT-II CONVERTER, malfunctions might be detected in self-diagnosis depending on control unit which carry out CAN communication.

- For details, refer to the separate "CONSULT-II Operations Manual".
- Turn ignition switch "OFF".
 - Connect CONSULT-II and CONSULT-II CONVERTER to data link connector, which is located in instrument lower panel on driver side.

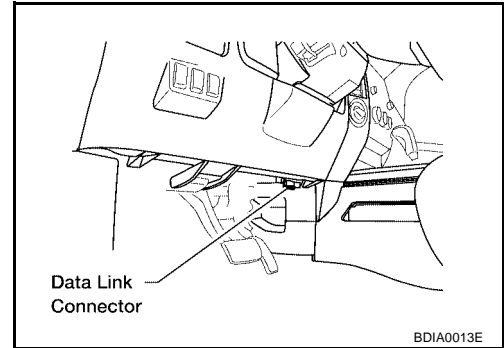

- Turn ignition switch "ON". (Do not start engine.)
- Touch "START (NISSAN BASED VHCL)".

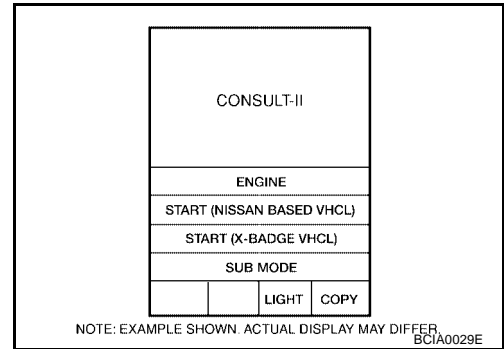

- Touch "A/T".
If "A/T" or "ENGINE" is not indicated, go to [GI-38, "CONSULT-II Data Link Connector \(DLC\) Circuit"](#).
- Perform each diagnostic test mode according to each service procedure.

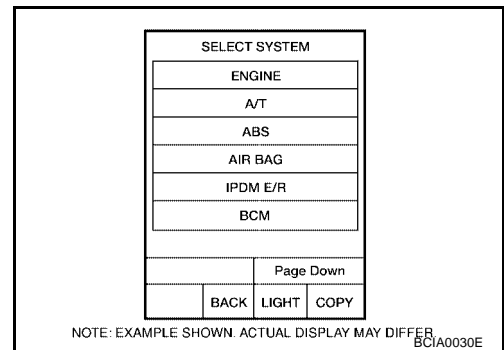

SELF-DIAGNOSTIC RESULT MODE

Operation Procedure

After performing "SELF-DIAGNOSTIC PROCEDURE (WITH CONSULT-II)" (Refer to [AT-87](#)), place check marks for results on the [AT-47, "DIAGNOSTIC WORKSHEET"](#). Reference pages are provided following the items.

- Perform "CONSULT-II SETTING PROCEDURE". Refer to [AT-87, "CONSULT-II SETTING PROCEDURE"](#)

TROUBLE DIAGNOSIS

2. Touch "SELF-DIAG RESULTS".
 Display shows malfunction experienced since the last erasing operation.

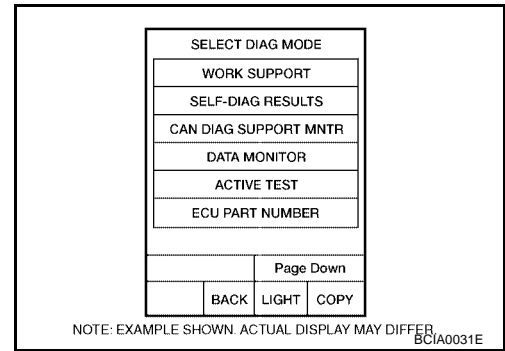

Display Items List

X: Applicable, —: Not applicable

Items (CONSULT-II screen terms)	Malfunction is detected when...	TCM self-diagnosis	OBD-II (DTC)
		"A/T" with CONSULT-II	MIL indicator lamp*1, "ENGINE" with CONSULT-II or GST
CAN COMM CIRCUIT	<ul style="list-style-type: none"> When a malfunction is detected in CAN communications 	U1000	U1000
STARTER RELAY/CIRC	<ul style="list-style-type: none"> If this signal is ON other than in P or N position, this is judged to be a malfunction. (And if it is OFF in P or N position, this too is judged to be a malfunction.) 	P0615	—
TCM	<ul style="list-style-type: none"> TCM is malfunctioning 	P0700	P0700
PNP SW/CIRC	<ul style="list-style-type: none"> PNP switch 1-4 signals input with impossible pattern P position is detected from N position without any other position being detected in between. 	P0705	P0705
VEH SPD SEN/CIR AT (Revolution sensor)	<ul style="list-style-type: none"> Signal from vehicle speed sensor A/T (Revolution sensor) not input due to cut line or the like Unexpected signal input during running After ignition switch is turned ON, unexpected signal input from vehicle speed sensor MTR before the vehicle starts moving 	P0720	P0720
ENGINE SPEED SIG	<ul style="list-style-type: none"> TCM does not receive the CAN communication signal from the ECM. 	P0725	—
TCC SOLENOID/CIRC	<ul style="list-style-type: none"> Normal voltage not applied to solenoid due to cut line, short, or the like 	P0740	P0740
A/T TCC S/V FNCTN	<ul style="list-style-type: none"> A/T cannot perform lock-up even if electrical circuit is good. TCM detects as irregular by comparing difference value with slip rotation. 	P0744	P0744*2
L/PRESS SOL/CIRC	<ul style="list-style-type: none"> Normal voltage not applied to solenoid due to cut line, short, or the like TCM detects as irregular by comparing target value with monitor value. 	P0745	P0745
TCM-RAM	<ul style="list-style-type: none"> TCM memory (RAM) is malfunctioning. 	P1702	—
TCM-ROM	<ul style="list-style-type: none"> TCM memory (ROM) is malfunctioning. 	P1703	—
TP SEN/CIRC A/T	<ul style="list-style-type: none"> TCM does not receive the proper accelerator pedal position signals (input by CAN communication) from ECM. 	P1705	—
ATF TEMP SEN/CIRC	<ul style="list-style-type: none"> During running, the ATF temperature sensor signal voltage is excessively high or low 	P1710	P0710
TURBINE REV S/CIRC	<ul style="list-style-type: none"> TCM does not receive the proper voltage signal from the sensor. TCM detects an irregularity only at position of 4th gear for turbine revolution sensor 2. 	P1716	P1716

TROUBLE DIAGNOSIS

Items (CONSULT-II screen terms)	Malfunction is detected when...	TCM self-diagnosis	OBD-II (DTC)	A
		"A/T" with CONSULT-II	MIL indicator lamp*1, "ENGINE" with CONSULT-II or GST	B
VEH SPD SE/CIR·MTR	<ul style="list-style-type: none"> ● Signal (CAN communication) from vehicle speed sensor MTR not input due to cut line or the like ● Unexpected signal input during running 	P1721	—	AT
A/T INTERLOCK	<ul style="list-style-type: none"> ● Except during shift change, the gear position and ATF pressure switch states are monitored and comparative judgement made. 	P1730	P1730	D
A/T 1ST E/BRAKING	<ul style="list-style-type: none"> ● Each ATF pressure switch and solenoid current is monitored and if a pattern is detected having engine braking 1st gear other than in the "M1" or "1" position, a malfunction is detected. 	P1731	—	E
I/C SOLENOID/CIRC	<ul style="list-style-type: none"> ● Normal voltage not applied to solenoid due to functional malfunction, cut line, short, or the like ● TCM detects as irregular by comparing target value with monitor value. 	P1752	P1752	F
I/C SOLENOID FNCTN	<ul style="list-style-type: none"> ● TCM detects that actual gear ratio is irregular, and relation between gear position and condition of ATF pressure switch 3 is irregular during depressing accelerator pedal. (Other than during shift change) ● TCM detects that relation between gear position and condition of ATF pressure switch 3 is irregular during releasing accelerator pedal. (Other than during shift change) 	P1754	P1754*2	G H
FR/B SOLENOID/CIRC	<ul style="list-style-type: none"> ● Normal voltage not applied to solenoid due to functional malfunction, cut line, short, or the like ● TCM detects as irregular by comparing target value with monitor value. 	P1757	P1757	I J
FR/B SOLENOID FNCT	<ul style="list-style-type: none"> ● TCM detects that actual gear ratio is irregular, and relation between gear position and condition of ATF pressure switch 1 is irregular during depressing accelerator pedal. (Other than during shift change) ● TCM detects that relation between gear position and condition of ATF pressure switch 1 is irregular during releasing accelerator pedal. (Other than during shift change) 	P1759	P1759*2	K L
D/C SOLENOID/CIRC	<ul style="list-style-type: none"> ● Normal voltage not applied to solenoid due to cut line, short, or the like ● TCM detects as irregular by comparing target value with monitor value. 	P1762	P1762	M
D/C SOLENOID FNCTN	<ul style="list-style-type: none"> ● TCM detects that actual gear ratio is irregular, and relation between gear position and condition of ATF pressure switch 5 is irregular during depressing accelerator pedal. (Other than during shift change) ● TCM detects that relation between gear position and condition of ATF pressure switch 5 is irregular during releasing accelerator pedal. (Other than during shift change) 	P1764	P1764*2	
HLR/C SOL/CIRC	<ul style="list-style-type: none"> ● Normal voltage not applied to solenoid due to functional malfunction, cut line, short, or the like ● TCM detects as irregular by comparing target value with monitor value. 	P1767	P1767	

TROUBLE DIAGNOSIS

Items (CONSULT-II screen terms)	Malfunction is detected when...	TCM self-diagnosis	OBD-II (DTC)
		"A/T" with CONSULT-II	MIL indicator lamp*1, "ENGINE" with CONSULT-II or GST
HLR/C SOL FNCTN	<ul style="list-style-type: none"> ● TCM detects that actual gear ratio is irregular, and relation between gear position and condition of ATF pressure switch 6 is irregular during depressing accelerator pedal. (Other than during shift change) ● TCM detects that relation between gear position and condition of ATF pressure switch 6 is irregular during releasing accelerator pedal. (Other than during shift change) 	P1769	P1769*2
LC/B SOLENOID/CIRC	<ul style="list-style-type: none"> ● Normal voltage not applied to solenoid due to functional malfunction, cut line, short, or the like 	P1772	P1772
LC/B SOLENOID FNCT	<ul style="list-style-type: none"> ● TCM detects an improper voltage drop when it tries to operate the solenoid valve. ● Condition of ATF pressure switch 2 is different from monitor value, and relation between gear position and actual gear ratio is irregular. 	P1774	P1774*2
MANU MODE SW/CIRC	<ul style="list-style-type: none"> ● When an impossible pattern of switch signals is detected, a malfunction is detected. 	P1815	—
ATF PRES SW 1/CIRC	<ul style="list-style-type: none"> ● TCM detects that actual gear ratio is normal, and relation between gear position and condition of ATF pressure switch 1 is irregular during depressing accelerator pedal. (Other than during shift change) 	P1841	—
ATF PRES SW 3/CIRC	<ul style="list-style-type: none"> ● TCM detects that actual gear ratio is normal, and relation between gear position and condition of ATF pressure switch 3 is irregular during depressing accelerator pedal. (Other than during shift change) 	P1843	—
ATF PRES SW 5/CIRC	<ul style="list-style-type: none"> ● TCM detects that actual gear ratio is normal, and relation between gear position and condition of ATF pressure switch 5 is irregular during depressing accelerator pedal. (Other than during shift change) 	P1845	—
ATF PRES SW 6/CIRC	<ul style="list-style-type: none"> ● TCM detects that actual gear ratio is normal, and relation between gear position and condition of ATF pressure switch 6 is irregular during depressing accelerator pedal. (Other than during shift change) 	P1846	—
NO DTC IS DETECTED FURTHER TESTING MAY BE REQUIRED	<ul style="list-style-type: none"> ● No NG item has been detected. 	X	X

*1: Refer to [AT-42, "Malfunction Indicator Lamp \(MIL\)"](#).

*2: These malfunctions cannot be displayed MIL if another malfunction is assigned to MIL.

How to Erase Self-diagnostic Results

1. Perform "CONSULT-II SETTING PROCEDURE". Refer to [AT-87, "CONSULT-II SETTING PROCEDURE"](#).
2. Touch "SELF-DAIG RESULTS".

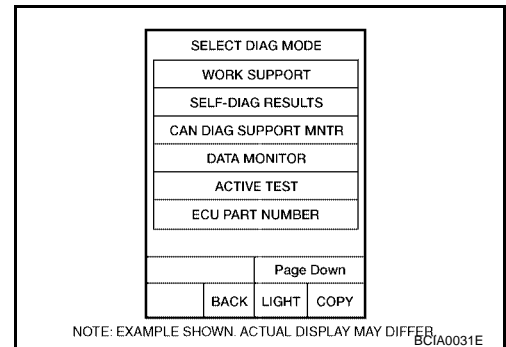

TROUBLE DIAGNOSIS

3. Touch "ERASE". (The self-diagnostic results will be erased.)

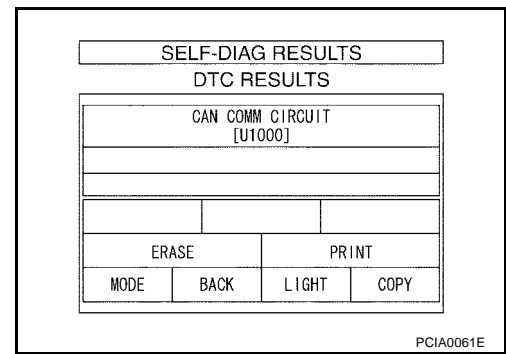

DATA MONITOR MODE

Operation Procedure

1. Perform "CONSULT-II SETTING PROCEDURE". Refer to [AT-87, "CONSULT-II SETTING PROCEDURE"](#).
2. Touch "DATA MONITOR".

NOTE:

When malfunction is detected, CONSULT-II performs "REAL-TIME DIAGNOSIS". Also, any malfunction detected while in this mode will be displayed at real time.

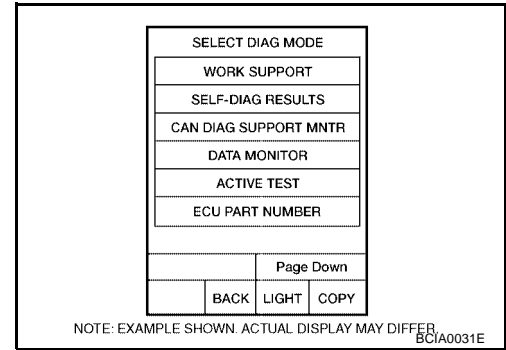

Display Items List

X: Standard, —: Not applicable

Monitored item (Unit)	Monitor Item Selection			Remarks
	ECU INPUT SIGNALS	MAIN SIGNALS	SELECTION FROM MENU	
VHCL/S SE·A/T (km/h)	X	X	X	Revolution sensor
VHCL/S SE·MTR (km/h)	X	—	X	
ACCELE POSI (0.0/8)	X	—	X	Accelerator pedal position signal
THROTTLE POSI (0.0/8)	X	X	X	Degree of opening for accelerator recognized by the TCM For fail-safe operation, the specific value used for control is displayed.
CLSD THL POS (ON-OFF display)	X	—	X	Signal input with CAN communications
W/O THL POS (ON-OFF display)	X	—	X	
BRAKE SW (ON-OFF display)	X	—	X	
GEAR	—	X	X	Gear position recognized by the TCM updated after gear-shifting
ENGINE SPEED (rpm)	X	X	X	
TURBINE REV (rpm)	X	X	X	
OUTPUT REV (rpm)	X	X	X	
GEAR RATIO	—	X	X	
TC SLIP SPEED (rpm)	—	X	X	Difference between engine speed and torque converter input shaft speed
F SUN GW REV (rpm)	—	—	X	

TROUBLE DIAGNOSIS

Monitored item (Unit)	Monitor Item Selection			Remarks
	ECU INPUT SIGNALS	MAIN SIGNALS	SELECTION FROM MENU	
F CARR GR REV (rpm)	—	—	X	
ATF TEMP SE 1 (V)	X	—	X	
ATF TEMP SE 2 (V)	X	—	X	
ATF TEMP 1 (°C)	—	X	X	
ATF TEMP 2 (°C)	—	X	X	
BATTERY VOLT (V)	X	—	X	
ATF PRES SW 1 (ON-OFF display)	X	X	X	(for FR/B solenoid)
ATF PRES SW 2 (ON-OFF display)	X	X	X	(for LC/B solenoid)
ATF PRES SW 3 (ON-OFF display)	X	X	X	(for I/C solenoid)
ATF PRES SW 5 (ON-OFF display)	X	X	X	(for D/C solenoid)
ATF PRES SW 6 (ON-OFF display)	X	X	X	(for HLR/C solenoid)
PNP SW 1 (ON-OFF display)	X	—	X	
PNP SW 2 (ON-OFF display)	X	—	X	
PNP SW 3 (ON-OFF display)	X	—	X	
PNP SW 4 (ON-OFF display)	X	—	X	
1 POSITION SW (ON-OFF display)	X	—	X	
SLCTLVR POSI	—	X	X	Selector lever position is recognized by the TCM. For fail-safe operation, the specific value used for control is displayed.
OD CONT SW (ON-OFF display)	X	—	X	4th position switch
POWER SHIFT SW (ON-OFF display)	X	—	X	Not mounted but displayed.
HOLD SW (ON-OFF display)	X	—	X	
MANU MODE SW (ON-OFF display)	X	—	X	
NON M-MODE SW (ON-OFF display)	X	—	X	
UP SW LEVER (ON-OFF display)	X	—	X	
DOWN SW LEVER (ON-OFF display)	X	—	X	
SFT UP ST SW (ON-OFF display)	—	—	X	Not mounted but displayed.
SFT DWN ST SW (ON-OFF display)	—	—	X	
ASCD-OD CUT (ON-OFF display)	—	—	X	
ASCD-CRUISE (ON-OFF display)	—	—	X	
ABS SIGNAL (ON-OFF display)	—	—	X	
ACC OD CUT (ON-OFF display)	—	—	X	
ACC SIGNAL (ON-OFF display)	—	—	X	
TCS GR/P KEEP (ON-OFF display)	—	—	X	
TCS SIGNAL 2 (ON-OFF display)	—	—	X	
TCS SIGNAL 1 (ON-OFF display)	—	—	X	
TCC SOLENOID (A)	—	X	X	
LINE PRES SOL (A)	—	X	X	
I/C SOLENOID (A)	—	X	X	
FR/B SOLENOID (A)	—	X	X	
D/C SOLENOID (A)	—	X	X	
HLR/C SOL (A)	—	X	X	

TROUBLE DIAGNOSIS

Monitored item (Unit)	Monitor Item Selection			Remarks	
	ECU INPUT SIGNALS	MAIN SIGNALS	SELECTION FROM MENU		
ON OFF SOL (ON-OFF display)	—	—	X	LC/B solenoid	A
TCC SOL MON (A)	—	—	X		B
L/P SOL MON (A)	—	—	X		AT
I/C SL MON (A)	—	—	X		
FR/B SOL MON (A)	—	—	X		
D/C SOL MON (A)	—	—	X		D
HLR/C SOL MON (A)	—	—	X		
ONOFF SOL MON (ON-OFF display)	—	—	X	LC/B solenoid	E
P POSI IND (ON-OFF display)	—	—	X		
R POSI IND (ON-OFF display)	—	—	X		
N POSI IND (ON-OFF display)	—	—	X		F
D POSI IND (ON-OFF display)	—	—	X		
4TH POSI IND (ON-OFF display)	—	—	X		G
3RD POSI IND (ON-OFF display)	—	—	X		
2ND POSI IND (ON-OFF display)	—	—	X		
1ST POSI IND (ON-OFF display)	—	—	X		H
MANU MODE IND (ON-OFF display)	—	—	X		
POWER M LAMP (ON-OFF display)	—	—	X		I
F-SAFE IND/L (ON-OFF display)	—	—	X		
ATF WARN LAMP (ON-OFF display)	—	—	X		
BACK-UP LAMP (ON-OFF display)	—	—	X		J
STARTER RELAY (ON-OFF display)	—	—	X		
PNP SW3 MON (ON-OFF display)	—	—	X		
C/V CLB ID1	—	—	X		K
C/V CLB ID2	—	—	X		
C/V CLB ID3	—	—	X		L
UNIT CLB ID1	—	—	X		
UNIT CLB ID2	—	—	X		
UNIT CLB ID3	—	—	X		M
TRGT GR RATIO	—	—	X		
TRGT PRES TCC (kPa)	—	—	X		
TRGT PRES L/P (kPa)	—	—	X		
TRGT PRES I/C (kPa)	—	—	X		
TRGT PRES FR/B (kPa)	—	—	X		
TRGT PRES D/C (kPa)	—	—	X		
TRG PRE HLR/C (kPa)	—	—	X		
SHIFT PATTERN	—	—	X		
DRV CST JUDGE	—	—	X		
START RLY MON	—	—	X		
NEXT GR POSI	—	—	X		
SHIFT MODE	—	—	X		
MANU GR POSI	—	—	X		

TROUBLE DIAGNOSIS

Monitored item (Unit)	Monitor Item Selection			Remarks
	ECU INPUT SIGNALS	MAIN SIGNALS	SELECTION FROM MENU	
VEHICLE SPEED (km/h)	—	X	X	Vehicle speed recognized by the TCM.
Voltage (V)	—	—	X	Displays the value measured by the voltage probe.
Frequency (Hz)	—	—	X	The value measured by the pulse probe is displayed.
DUTY-HI (high) (%)	—	—	X	
DUTY-LOW (low) (%)	—	—	X	
PLS WIDTH-HI (ms)	—	—	X	
PLS WIDTH-LOW (ms)	—	—	X	

DTC WORK SUPPORT MODE

Operation Procedure

1. Perform "CONSULT-II SETTING PROCEDURE". Refer to [AT-87, "CONSULT-II SETTING PROCEDURE"](#)
2. Touch "DTC WORK SUPPORT".

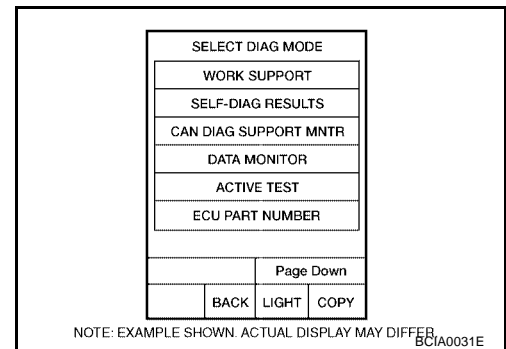

3. Touch select item menu.

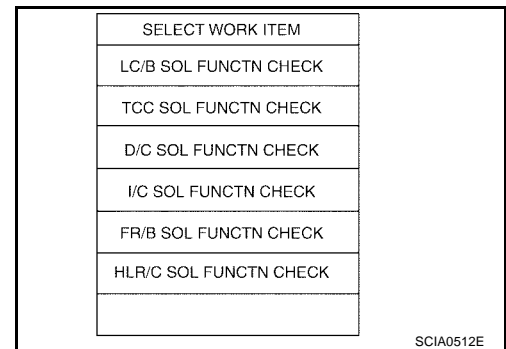

4. Touch "START".

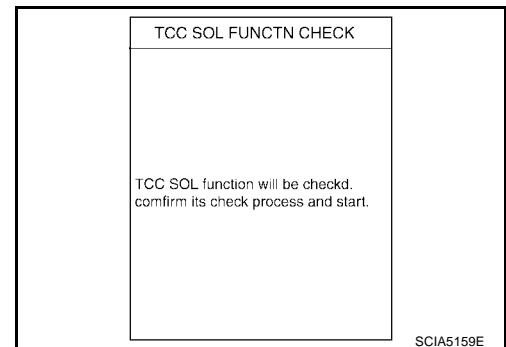

TROUBLE DIAGNOSIS

5. Perform driving test according to "DTC CONFIRMATION PROCEDURE" in "TROUBLE DIAGNOSIS FOR DTC".

TCC SOL FUNCTN CHECK	
OUT OF CONDITION	
MONITOR	
ACCELE POSI	XXX
GEAR	XXX
TCC SOLENOID	XXXA
VEHICLE SPEED	XXXkm/h
SCIA5160E	

- When testing conditions are satisfied, CONSULT-II screen changes from "OUT OF CONDITION" to "TESTING".

TCC SOL FUNCTN CHECK	
TESTING	
MONITOR	
ACCELE POSI	XXX
GEAR	XXX
TCC SOLENOID	XXXA
VEHICLE SPEED	XXXkm/h
SCIA5161E	

6. Stop vehicle.

TCC SOL FUNCTN CHECK	
STOP VEHICLE	
SCIA5164E	

- If "NG" appears on the screen, malfunction may exist. Go to "Diagnostic Procedure".

TCC SOL FUNCTN CHECK	
NG	
SCIA5162E	

A
B
AT
D
E
F
G
H
I
J
K
L
M

TROUBLE DIAGNOSIS

7. Perform test drive to check gear shift feeling in accordance with instructions displayed.
8. Touch "YES" or "NO".
9. CONSULT-II procedure is ended.

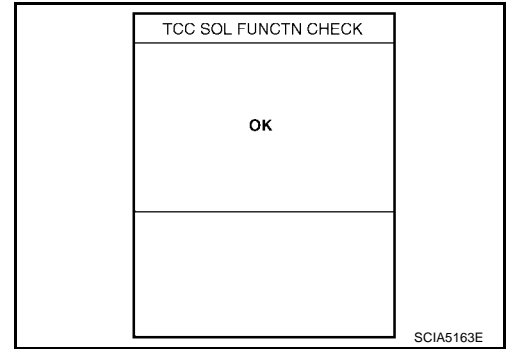

- If "NG" appears on the screen, malfunction may exist. Go to "Diagnostic Procedure".

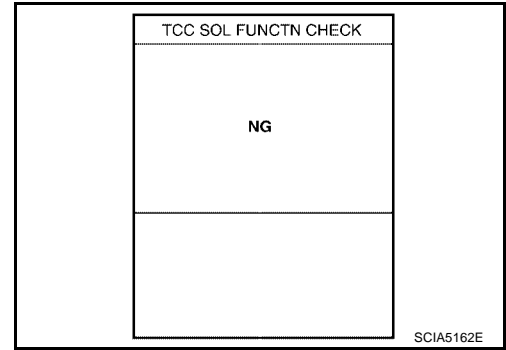

Display Items List

DTC work support item	Description	Check item
I/C SOL FUNCTN CHECK*	—	—
FR/B SOL FUNCTN CHECK*	—	—
D/C SOL FUNCTN CHECK*	—	—
HLR/C SOL FUNCTN CHECK*	—	—
LC/B SOL FUNCTN CHECK*	—	—
TCC SOL FUNCTN CHECK	Following items for "TCC solenoid function (lock-up) " can be confirmed. ● Self-diagnosis status (whether the diagnosis is being performed or not) ● Self-diagnosis result (OK or NG)	● TCC solenoid valve ● Hydraulic control circuit

*: Do not use, but displayed.

DTC U1000 CAN COMMUNICATION LINE

DTC U1000 CAN COMMUNICATION LINE

PF2:23710

Description

ECS00AWY

CAN (Controller Area Network) is a serial communication line for real time application. It is an on-vehicle multiplex communication line with high data communication speed and excellent malfunction detection ability. Many electronic control units are equipped onto a vehicle, and each control unit shares information and links with other control units during operation (not independent). In CAN communication, control units are connected with 2 communication lines (CAN H line, CAN L line) allowing a high rate of information transmission with less wiring. Each control unit transmits/receives data but selectively reads required data only.

On Board Diagnosis Logic

ECS00AWZ

- This is an OBD-II self-diagnostic item.
- Diagnostic trouble code "U1000 CAN COMM CIRCUIT" with CONSULT-II is detected when TCM cannot communicate to other control units.

Possible Cause

ECS00AX0

Harness or connectors
(CAN communication line is open or shorted.)

DTC Confirmation Procedure

ECS00AX1

NOTE:

If "DTC Confirmation Procedure" has been previously performed, always turn ignition switch "OFF" and wait at least 10 seconds before performing the next test.

After the repair, perform the following procedure to confirm the malfunction is eliminated.

WITH CONSULT-II

1. Turn ignition switch "ON". (Do not start engine.)
2. Select "DATA MONITOR" mode for "ENGINE" with CONSULT-II.
3. Start engine and wait for at least 6 seconds.
4. If DTC is detected, go to [AT-99, "Diagnostic Procedure"](#).

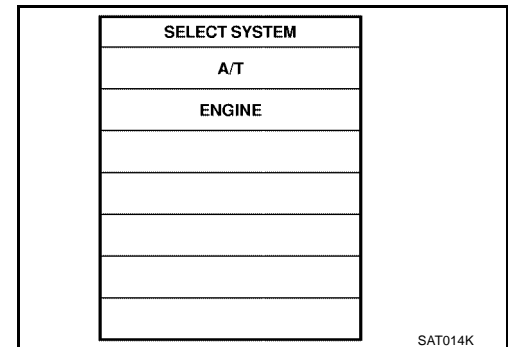

WITH GST



Follow the procedure "WITH CONSULT-II".

DTC U1000 CAN COMMUNICATION LINE

Wiring Diagram — AT — CAN

ECS00CBW

AT-CAN-01

-  : DETECTABLE LINE FOR DTC
-  : NON-DETECTABLE LINE FOR DTC
-  : DATA LINE

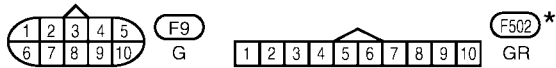
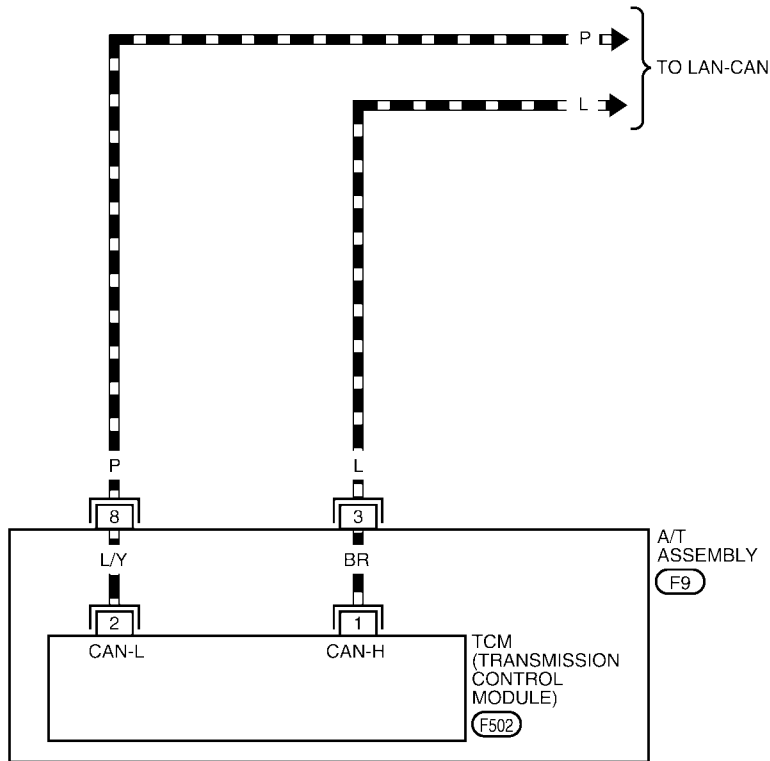

★: THIS CONNECTOR IS NOT SHOWN IN "HARNESS LAYOUT" OF PG SECTION.

BCWA0320E

DTC U1000 CAN COMMUNICATION LINE

TCM terminals and data are reference value. Measured between each terminal and ground

Terminal	Wire Color	Item	Condition	Data (Approx.)
3	L	CAN-H	-	-
8	P	CAN-L	-	-

Diagnostic Procedure

ECS00AX2

1. CHECK CAN COMMUNICATION CIRCUIT

④ With CONSULT-II

- Turn ignition switch "ON" and start engine.
- Select "SELF-DIAG RESULTS" mode for "A/T" with CONSULT-II.

Is any malfunction of the "CAN COMM CIRCUIT" indicated?

YES >> Print out CONSULT-II screen, GO TO LAN section.
Refer to [LAN-5, "Precautions When Using CONSULT-II"](#)

NO >> **INSPECTION END**

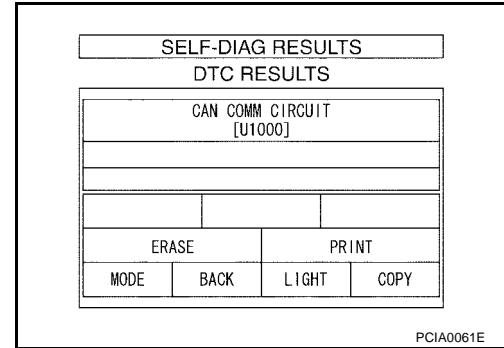

DTC P0615 START SIGNAL CIRCUIT

DTC P0615 START SIGNAL CIRCUIT

PF:25230

Description

ECS00AX3

- TCM prohibits cranking other than at "P" or "N" position.

CONSULT-II Reference Value

ECS00AX4

Item name	Condition	Display value
STARTER RELAY	Selector lever in "N", "P" position.	ON
	Selector lever in other position.	OFF

On Board Diagnosis Logic

ECS00AX5

- This is not an OBD-II self-diagnostic item.
- Diagnostic trouble code "P0615 STARTER RELAY/CIRC" with CONSULT-II is detected when park/neutral (PNP) relay (starter relay) is switched "ON" other than at "P" or "N" position. (Or when switched "OFF" at "P" or "N" position).

Possible Cause

ECS00AX6

- Harness or connectors
[The park/neutral position (PNP) relay (starter relay) and TCM circuit is open or shorted.]
- Park/neutral position (PNP) relay (starter relay)

DTC Confirmation Procedure

ECS00AX7

NOTE:

If "DTC Confirmation Procedure" has been previously performed, always turn ignition switch "OFF" and wait at least 10 seconds before performing the next test.

After the repair, perform the following procedure to confirm the malfunction is eliminated.

Ⓟ WITH CONSULT-II

1. Turn ignition switch "ON". (Do not start engine.)
2. Select "DATA MONITOR" mode for "A/T" with CONSULT-II.
3. Start engine.
4. Drive vehicle for at least 2 consecutive seconds.
5. If DTC is detected, go to [AT-102, "Diagnostic Procedure"](#).

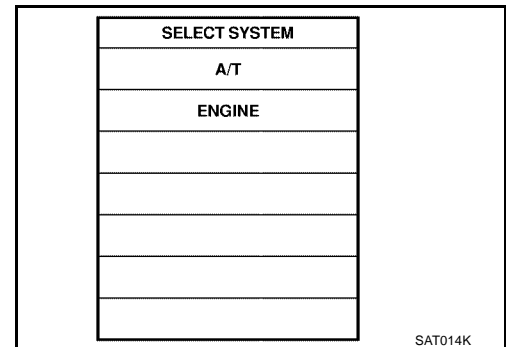

DTC P0615 START SIGNAL CIRCUIT

Wiring Diagram — AT — STSIG

ECS00CBX

AT-STSIG-01

: DETECTABLE LINE FOR DTC
 : NON-DETECTABLE LINE FOR DTC

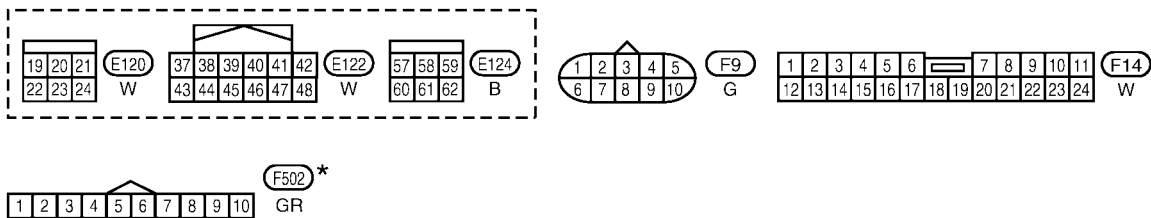
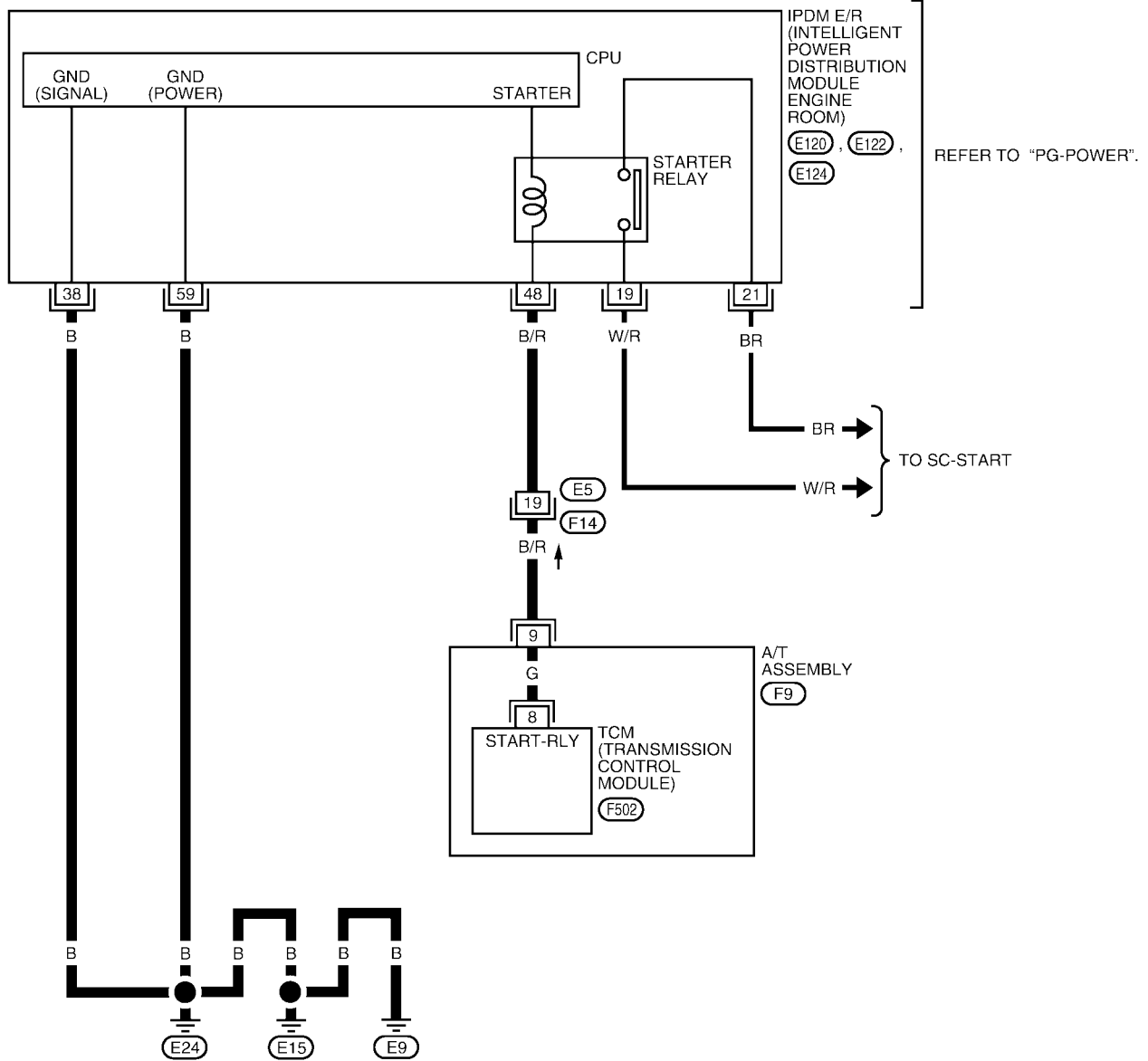

* : THIS CONNECTOR IS NOT SHOWN IN "HARNESS LAYOUT" OF PG SECTION.

BCWA0321E

DTC P0615 START SIGNAL CIRCUIT

TCM terminals and data are reference value. Measured between each terminal and ground.

Terminal	Wire color	Item	Condition	Data (Approx.)
9	B/R	Starter relay	 Selector lever in "N" and "P" positions.	Battery voltage
			Selector lever in other positions.	0V

Diagnostic Procedure

ECS00CBY

1. CHECK STARTER RELAY

With CONSULT-II

- Turn ignition switch ON. (Do not start engine.)
- Select "SELECTION FROM MENU" in "DATA MONITOR" mode for "A/T" with CONSULT-II and check monitor "STARTER RELAY" ON/OFF.

Item name	Condition	Display value
STARTER RELAY	Selector lever in "N" and "P" positions.	ON
	Selector lever in other positions.	OFF

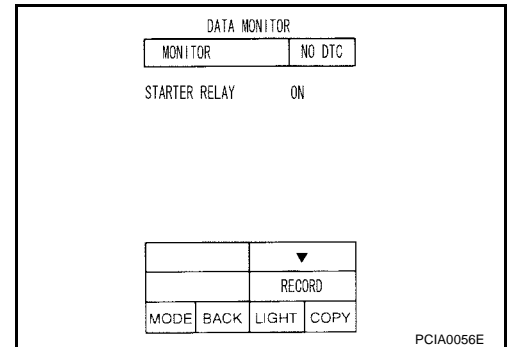

Without CONSULT-II

- Turn ignition switch ON. (Do not start engine.)
- Check voltage between the IPDM E/R connector and ground.

Item	Connector	Terminal (Wiring color)		Shift position	Voltage (Approx.)
Starter relay	E122	48 (B/R)	Ground	"N" and "P"	Battery voltage
				"R" and "D"	0V

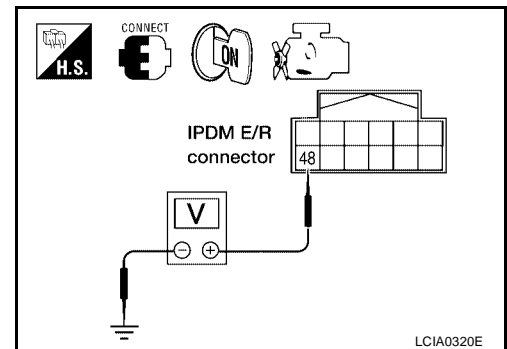

OK or NG

- OK >> GO TO 5.
 NG >> GO TO 2.

2. CHECK HARNESS BETWEEN A/T ASSEMBLY HARNESS CONNECTOR AND IPDM E/R CONNECTOR

- Turn ignition switch OFF.
- Disconnect A/T assembly harness connector and IPDM E/R connector.
- Check continuity between A/T assembly harness connector and IPDM E/R connector.

Item	Connector	Terminal (Wire color)	Continuity
A/T assembly harness connector	F9	9 (B/R)	Yes
IPDM E/R connector	E122	48 (B/R)	

- If OK, check harness for short to ground and short to power.
- Reinstall any part removed.

OK or NG

- OK >> GO TO 3.
 NG >> Repair open circuit or short to ground or short to power in harness or connectors.

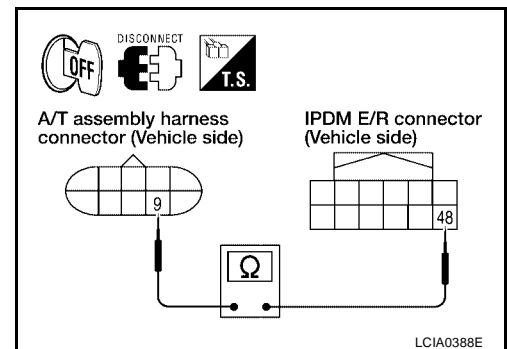

DTC P0615 START SIGNAL CIRCUIT

3. CHECK TERMINAL CORD ASSEMBLY

1. Remove control valve with TCM. Refer to [AT-250, "Control Valve With TCM and A/T Fluid Temperature Sensor 2"](#) .
2. Disconnect A/T assembly harness connector and TCM connector.
3. Check continuity between A/T assembly harness connector terminal and TCM connector terminal.

Item	Connector	Terminal (Wire color)	Continuity
A/T assembly harness connector	F9	9 (G)	Yes
TCM connector	F502	8 (G)	

4. If OK, check harness for short to ground and short to power.
5. Reinstall any part removed.

OK or NG

- OK >> GO TO 4.
- NG >> Repair open circuit or short to ground and short to power in harness or connectors.

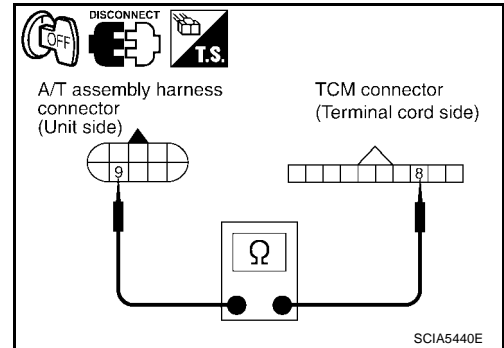

4. DETECT MALFUNCTIONING ITEM

Check the following items:

- Starter relay, Refer to [SC-10, "STARTING SYSTEM"](#) .
- IPDM E/R, Refer to [PG-16, "IPDM E/R \(INTELLIGENT POWER DISTRIBUTION MODULE ENGINE ROOM\)"](#) .

OK or NG

- OK >> Replace the control valve with TCM. Refer to [AT-250, "Control Valve With TCM and A/T Fluid Temperature Sensor 2"](#) .
- NG >> Repair or replace damaged parts.

5. CHECK DTC

Perform "DTC Confirmation Procedure".

- Refer to [AT-100, "DTC Confirmation Procedure"](#) .

OK or NG

- OK >> **INSPECTION END**
- NG >> GO TO 2.

DTC P0700 TCM

PF3:31036

Description

ECS00AX9

The TCM consists of a microcomputer and connectors for signal input and output and for power supply. The TCM controls the A/T.

On Board Diagnosis Logic

ECS00AXA

- This is an OBD-II self-diagnostic item.
- Diagnostic trouble code "P0700 TCM" with CONSULT-II is detected when the TCM is malfunctioning.

Possible Cause

ECS00AXB

TCM.

DTC Confirmation Procedure

ECS00AXC

NOTE:

If "DTC Confirmation Procedure" has been previously performed, always turn ignition switch "OFF" and wait at least 10 seconds before performing the next test.

After the repair, perform the following procedure to confirm the malfunction is eliminated.

WITH CONSULT-II

1. Turn ignition switch "ON". (Do not start engine.)
2. Select "DATA MONITOR" mode for "A/T" with CONSULT-II.
3. Start engine.
4. Run engine for at least 2 consecutive seconds at idle speed.
5. If DTC is detected, go to [AT-104, "Diagnostic Procedure"](#).

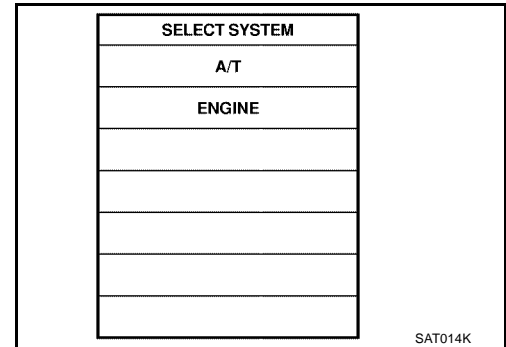

WITH GST

Follow the procedure "With CONSULT-II".

Diagnostic Procedure

ECS00AXD

1. CHECK DTC

With CONSULT-II

1. Turn ignition switch "ON". (Do not start engine.)
2. Select "SELF DIAG RESULTS" mode for "A/T" with CONSULT-II.
3. Touch "ERASE".
4. Turn ignition switch "OFF" and wait at least 10 seconds.
5. Perform DTC confirmation procedure, [AT-104, "DTC Confirmation Procedure"](#).

Is the "TCM" displayed again?

YES >> Replace the control valve with TCM. Refer to [AT-250, "CONTROL VALVE WITH TCM REMOVAL AND INSTALLATION"](#).

NO >> **INSPECTION END**

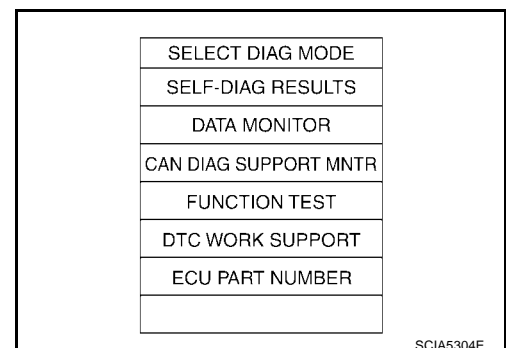

DTC P0705 PARK/NEUTRAL POSITION SWITCH

DTC P0705 PARK/NEUTRAL POSITION SWITCH

PF3:32006

Description

ECS00AXE

- The park/neutral position (PNP) switch includes a transmission position switch.
- The transmission range switch detects the selector lever position and sends a signal to the TCM.

CONSULT-II Reference Value

ECS00AXF

Item name	Condition	Display value
SLCTLVR POSI	Selector lever in "N", "P" positions.	N/P
	Selector lever in "R" position.	R
	Selector lever in "D" position.	D
	Selector lever in "4" position.	4
	Selector lever in "3" position.	3
	Selector lever in "2" position.	2
	Selector lever in "1" position.	1

On Board Diagnosis Logic

ECS00AXG

- This is an OBD-II self-diagnostic item.
- Diagnostic trouble code "P0705 PNP SW/CIRC" with CONSULT-II is detected under the following conditions.
 - When TCM does not receive the correct voltage signal from the PNP switch 1, 2, 3, 4 based on the gear position.
 - When no other position but "P" position is detected from "N" positions.

Possible Cause

ECS00AXH

- Harness or connectors
[The park/neutral position (PNP) switch 1, 2, 3, 4 and TCM circuit is open or shorted.]
- Park/neutral position (PNP) switch 1, 2, 3, 4

DTC Confirmation Procedure

ECS00AXI

CAUTION:

Always drive vehicle at a safe speed.

NOTE:

If "DTC Confirmation Procedure" has been previously performed, always turn ignition switch "OFF" and wait at least 10 seconds before performing the next test.

After the repair, perform the following procedure to confirm the malfunction is eliminated.

WITH CONSULT-II

1. Turn ignition switch "ON". (Do not start engine.)
2. Select "DATA MONITOR" mode for "ENGINE" with CONSULT-II.
3. Start engine.
4. Drive vehicle and maintain the following conditions for at least 2 consecutive seconds.
THRTL POS SEN: More than 1.2V
5. If DTC is detected, go to [AT-107, "Diagnostic Procedure"](#).

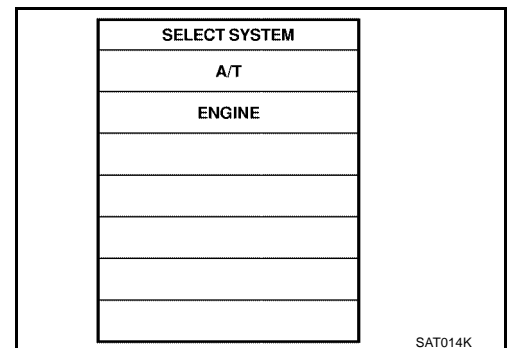

WITH GST

Follow the procedure "With CONSULT-II".

DTC P0705 PARK/NEUTRAL POSITION SWITCH

ECS00CBZ

Wiring Diagram — AT — PNP/SW

AT-PNP/SW-01

— : DETECTABLE LINE FOR DTC
— : NON-DETECTABLE LINE FOR DTC

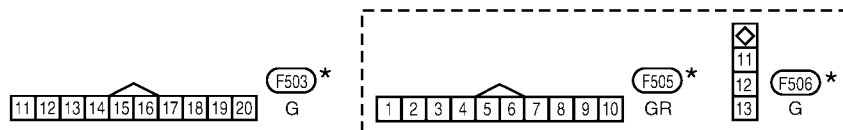
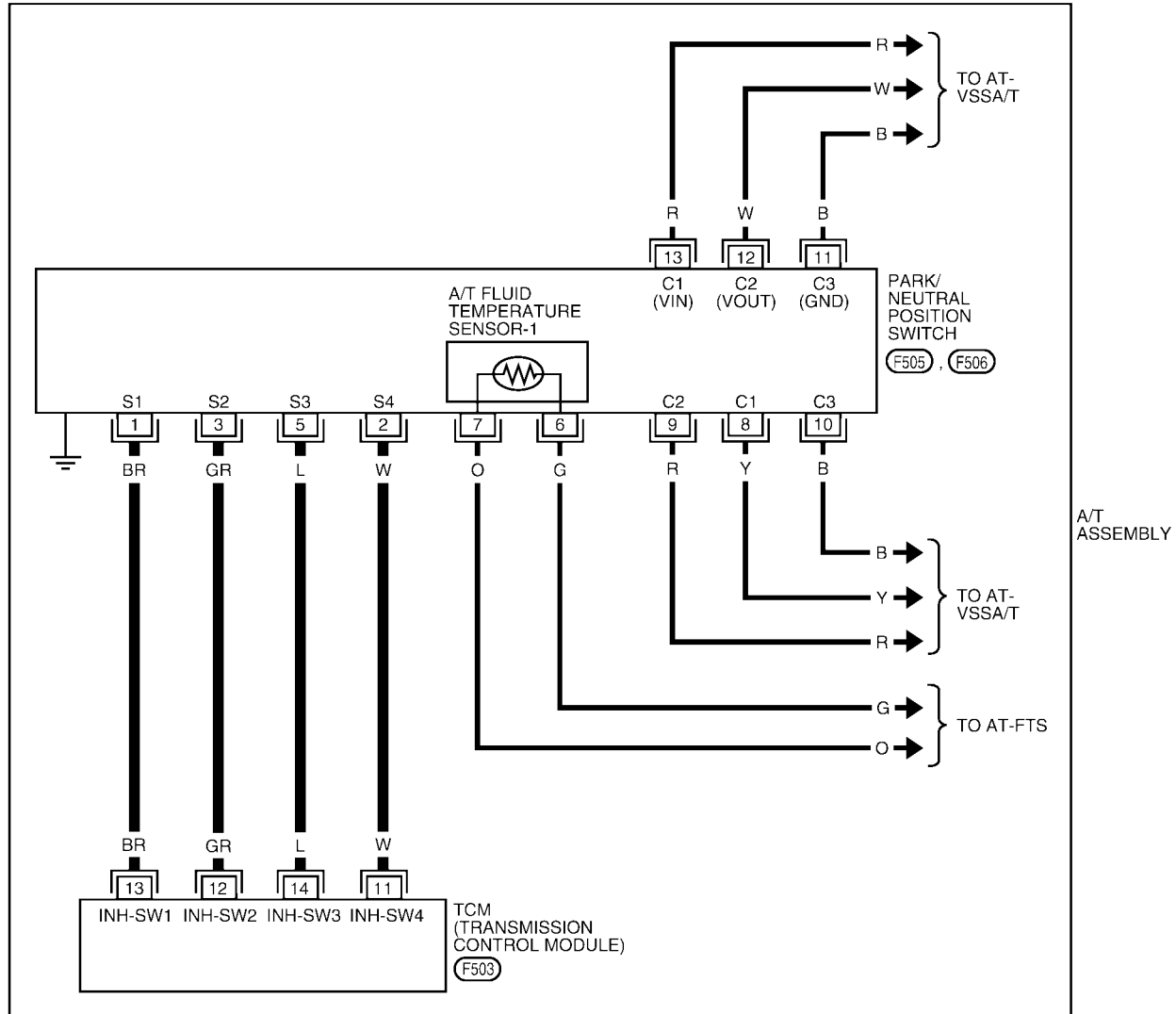

*: THIS CONNECTOR IS NOT SHOWN IN "HARNESS LAYOUT" OF PG SECTION.

BCWA0334E

DTC P0705 PARK/NEUTRAL POSITION SWITCH

ECS00CC0

Diagnostic Procedure

1. CHECK PNP SW CIRCUIT

With CONSULT-II

1. Turn ignition switch ON. (Do not start engine.)
2. Select "SELECTION FROM MENU" in "DATA MONITOR" mode for "A/T" with CONSULT-II.
3. Check if correct selector lever position (N/P, R or D) is displayed as selector lever is moved into each position.

DATA MONITOR	
MONITOR	NO. DTC
ATF PRES SW 2	OFF
ATF PRES SW 3	OFF
ATF PRES SW 5	OFF
ATF PRES SW 6	OFF
SLCT LVR POSI	N·P

Δ	▽		
RECORD			
MODE	BACK	LIGHT	COPY

PCIA0034E

Item name	Condition	Display value
SLCTLVR POSI	Selector lever in "N", "P" positions.	N/P
	Selector lever in "R" position.	R
	Selector lever in "D" position.	D
	Selector lever in "4" position.	4
	Selector lever in "3" position.	3
	Selector lever in "2" position.	2
	Selector lever in "1" position.	1

OK or NG

- OK >> GO TO 5.
- NG >> GO TO 2.

2. CHECK TCM POWER SUPPLY AND GROUND CIRCUIT

Check TCM power supply and ground circuit. Refer to [AT-174, "MAIN POWER SUPPLY AND GROUND CIRCUIT"](#).

OK or NG

- OK >> GO TO 3.
- NG >> Repair or replace damaged parts.

3. DETECT MALFUNCTIONING ITEM

Check the following items:

- A/T assembly harness connector pin terminals for damage or loose connection with harness connector.

OK or NG

- OK >> GO TO 4.
- NG >> Repair or replace damaged parts.

DTC P0705 PARK/NEUTRAL POSITION SWITCH

4. CHECK SUB-HARNESS

1. Remove control valve with TCM. Refer to [AT-250, "Control Valve With TCM and A/T Fluid Temperature Sensor 2"](#) .
2. Disconnect park/neutral position switch connector and TCM connector.
3. Check continuity between park/neutral position switch connector terminals and TCM connector terminals.

Item	Connector	Terminal (Wire color)	Continuity
Park/neutral position switch connector	F505	1 (BR)	Yes
TCM connector	F503	13 (BR)	
Park/neutral position switch connector	F505	2 (W)	Yes
TCM connector	F503	11 (W)	
Park/neutral position switch connector	F505	3 (GR)	Yes
TCM connector	F503	12 (GR)	
Park/neutral position switch connector	F505	5 (L)	Yes
TCM connector	F503	14 (L)	

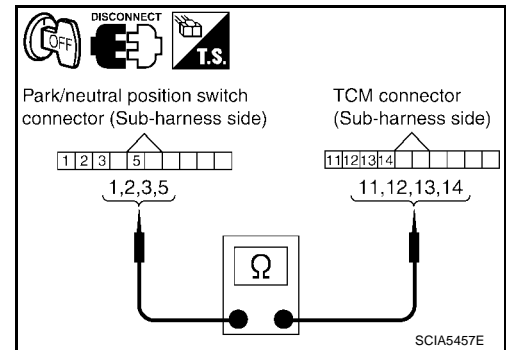

4. If OK, check harness for short to ground and short to power.

5. Reinstall any part removed.

OK or NG

- OK >> Replace the control valve with TCM. Refer to [AT-250, "Control Valve With TCM and A/T Fluid Temperature Sensor 2"](#) .
- NG >> Replace open circuit or short to ground and short to power in harness or connectors.

5. CHECK DTC

Perform "DTC Confirmation Procedure".

- Refer to [AT-105, "DTC Confirmation Procedure"](#) .

OK or NG

- OK >> **INSPECTION END**
- NG >> GO TO 2.

DTC P0720 VEHICLE SPEED SENSOR A/T (REVOLUTION SENSOR)

DTC P0720 VEHICLE SPEED SENSOR A/T (REVOLUTION SENSOR)

PF3:32702

Description

ECS00AXK

The revolution sensor detects the revolution of the idler gear parking pawl lock gear and emits a pulse signal. The pulse signal is sent to the TCM which converts it into vehicle speed.

CONSULT-II Reference Value

ECS00AXL

Item name	Condition	Display value (km/h)
VHCL/S SE·A/T	During driving	Approximately matches the speedometer reading.

On Board Diagnosis Logic

ECS00AXM

- This is an OBD-II self-diagnostic item.
- Diagnostic trouble code “P0720 VEH SPD SEN/CIR AT” with CONSULT-II is detected under the following conditions.
 - When TCM does not receive the proper voltage signal from the sensor.
 - After ignition switch is turned “ON”, irregular signal input from vehicle speed sensor MTR before the vehicle starts moving.

Possible Cause

ECS00AXN

- Harness or connectors
(The sensor circuit is open or shorted.)
- Revolution sensor
- Vehicle speed sensor MTR

DTC Confirmation Procedure

ECS00AXO

CAUTION:

- Always drive vehicle at a safe speed.
- Be careful not to rev engine into the red zone on the tachometer.

NOTE:

If “DTC Confirmation Procedure” has been previously performed, always turn ignition switch “OFF” and wait at least 10 seconds before performing the next test.

After the repair, perform the following procedure to confirm the malfunction is eliminated.

WITH CONSULT-II

1. Turn ignition switch “ON”. (Do not start engine.)
2. Select “DATA MONITOR” mode for “A/T” with CONSULT-II.
3. Drive vehicle and check for an increase of “VHCL/S SE·A/T” value in response to “VHCL/S SE·MTR” value.
If the check result is NG, go to [AT-112, "Diagnostic Procedure"](#) .
If the check result is OK, go to following step.
4. Select “DATA MONITOR” mode for “ENGINE” with CONSULT-II.
5. Start engine and maintain the following conditions for at least 5 consecutive seconds.
VHCL SPEED SE: 30 km/h (19 MPH) or more
THRTL POS SEN: More than 1.0/8
Selector lever: “D” position
Driving location: Driving the vehicle uphill (increased engine load) will help maintain the driving conditions required for this test.
If the check result is NG, go to [AT-112, "Diagnostic Procedure"](#) .
If the check result is OK, go to following step.
6. Maintain the following conditions for at least 5 consecutive seconds.
ENGINE SPEED: 3,500 rpm or more
THRTL POS SEN: More than 1.0/8
Selector lever: “D” position
Driving location: Driving the vehicle uphill (increased engine load) will help maintain the driving conditions required for this test.
If the check result is NG, go to [AT-112, "Diagnostic Procedure"](#) .

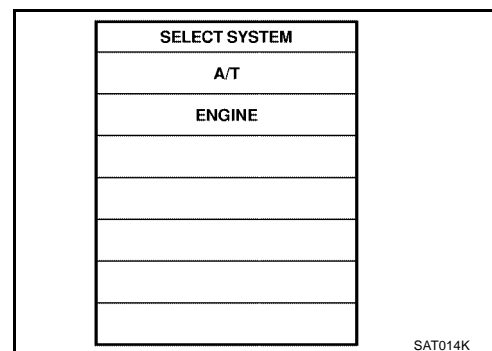

DTC P0720 VEHICLE SPEED SENSOR A/T (REVOLUTION SENSOR)



WITH GST

Follow the procedure "With CONSULT-II".

DTC P0720 VEHICLE SPEED SENSOR A/T (REVOLUTION SENSOR)

Wiring Diagram — AT — VSSA/T

ECS00CC1

AT-VSSA/T-01

: DETECTABLE LINE FOR DTC
 : NON-DETECTABLE LINE FOR DTC

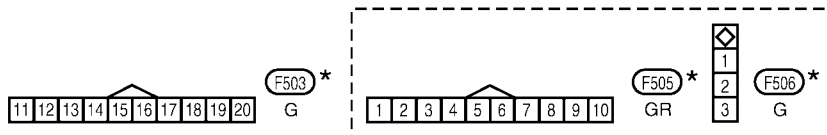
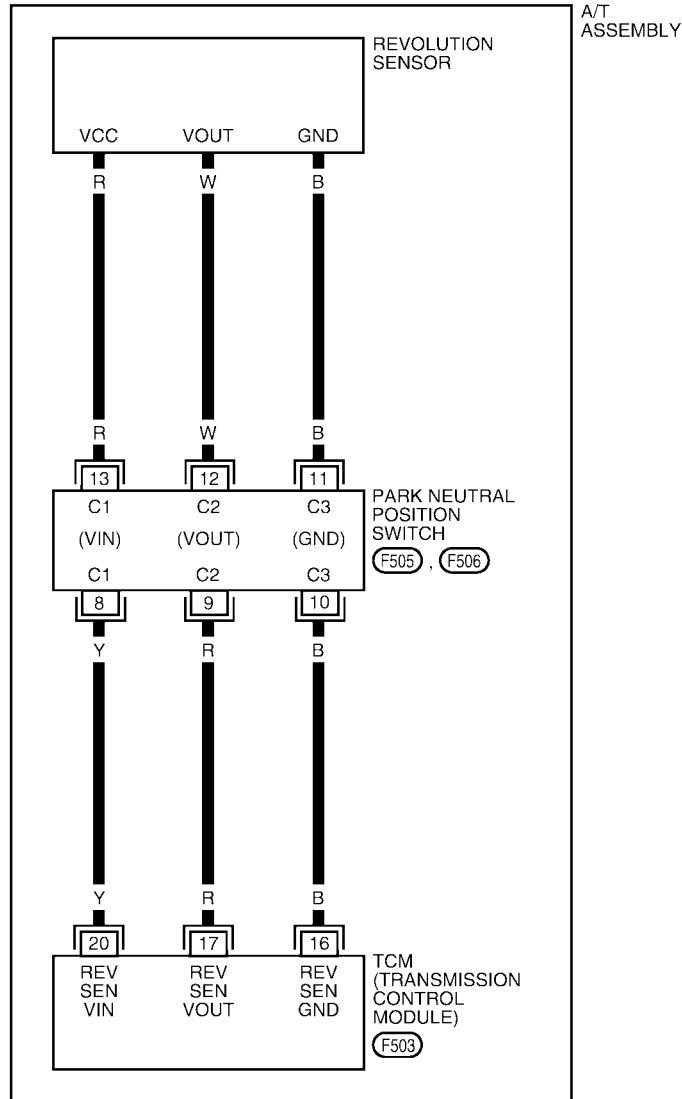

* : THIS CONNECTOR IS NOT SHOWN IN "HARNESS LAYOUT" OF PG SECTION.

BCWA0322E

DTC P0720 VEHICLE SPEED SENSOR A/T (REVOLUTION SENSOR)

ECS00CC2

Diagnostic Procedure

1. CHECK INPUT SIGNAL

With CONSULT-II

1. Turn ignition switch ON.
2. Select "ECU INPUT SIGNALS" in "DATA MONITOR" mode for "A/T" with CONSULT-II.
3. Start the engine.
4. Read out the value of "VHCL/S SE-A/T" while driving.
Check the value changes according to driving speed.

DATA MONITOR	
MONITOR	NO DTC
VHCL/S SE-A/T	0km/h
VHCL/S SE-MTR	0km/h
ACCELE POSI	0.0/8
THROTTLE POS	0.0/8
CLSD THL POS	ON
W/O THL POS	OFF
	▽
RECORD	
MODE	BACK
LIGHT	COPY

SCIA2148E

Item name	Condition	Display value (km/h)
VHCL/S SE-A/T	During driving	Approximately matches the speedometer reading.

OK or NG

- OK >> GO TO 6.
NG >> GO TO 2.

2. CHECK TCM POWER SUPPLY AND GROUND CIRCUIT

Check TCM power supply and ground circuit. Refer to [AT-174, "MAIN POWER SUPPLY AND GROUND CIRCUIT"](#).

OK or NG

- OK >> GO TO 3.
NG >> Repair or replace damaged parts.

3. DETECT MALFUNCTIONING ITEM

Check the following items:

- The A/T assembly harness connector pin terminals for damage or loose connection with harness connector.

OK or NG

- OK >> GO TO 4.
NG >> Repair or replace damaged parts.

DTC P0720 VEHICLE SPEED SENSOR A/T (REVOLUTION SENSOR)

4. CHECK SUB-HARNESS

1. Remove control valve with TCM. Refer to [AT-250, "Control Valve With TCM and A/T Fluid Temperature Sensor 2"](#) .
2. Disconnect park/neutral position switch connector and TCM connector.
3. Check continuity between park/neutral position switch connector terminals and TCM connector terminals.

Item	Connector	Terminal (Wire color)	Continuity
Park/neutral position switch connector	F505	8 (Y)	Yes
TCM connector	F503	20 (Y)	
Park/neutral position switch connector	F505	9 (R)	Yes
TCM connector	F503	17 (R)	
Park/neutral position switch connector	F505	10 (B)	Yes
TCM connector	F503	16 (B)	

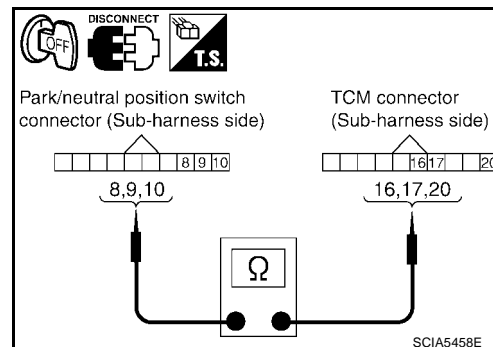

4. If OK, check harness for short to ground and short to power.
5. Reinstall any part removed.

OK or NG

OK >> GO TO 5.

NG >> Replace open circuit or short to ground and short to power in harness or connectors.

5. REPLACE THE REVOLUTION SENSOR AND CHECK DTC

1. Replace the revolution sensor. Refer to [AT-283, "Disassembly"](#) .
2. Perform "DTC Confirmation Procedure". Refer to [AT-109, "DTC Confirmation Procedure"](#) .

OK or NG

OK >> **INSPECTION END**

NG >> Replace the control valve with TCM. Refer to [AT-250, "Control Valve With TCM and A/T Fluid Temperature Sensor 2"](#) .

6. CHECK DTC

Perform "DTC Confirmation Procedure".

- Refer to [AT-109, "DTC Confirmation Procedure"](#) .

OK or NG

OK >> **INSPECTION END**

NG >> GO TO 2.

DTC P0725 ENGINE SPEED SIGNAL

DTC P0725 ENGINE SPEED SIGNAL

PF0:24825

Description

ECS00AXQ

The engine speed signal is sent from the ECM to the TCM.

CONSULT-II Reference Value

ECS00AXR

Item name	Condition	Display value (rpm)
ENGINE SPEED	Engine running	Closely matches the tachometer reading.

On Board Diagnosis Logic

ECS00AXS

- This is not an OBD-II self-diagnostic item.
- Diagnostic trouble code "P0725 ENGINE SPEED SIG" with CONSULT-II is detected when TCM does not receive the ignition signal from ECM during engine cranking or running.

Possible Cause

ECS00AXT

Harness or connectors
(The ECM to the TCM circuit is open or shorted.)

DTC Confirmation Procedure

ECS00AXU

CAUTION:

Always drive vehicle at a safe speed.

NOTE:

If "DTC Confirmation Procedure" has been previously performed, always turn ignition switch "OFF" and wait at least 10 seconds before performing the next test.

After the repair, perform the following procedure to confirm the malfunction is eliminated.

WITH CONSULT-II

1. Turn ignition switch "ON" and select "DATA MONITOR" mode for "A/T" with CONSULT-II.
2. Start engine and maintain the following conditions for at least 10 consecutive seconds.
VHCL SPEED SE: 10 km/h (6 MPH) or more
ACCELE POSI: More than 1/8
Selector lever: "D" position
3. If DTC is detected, go to [AT-114, "Diagnostic Procedure"](#).

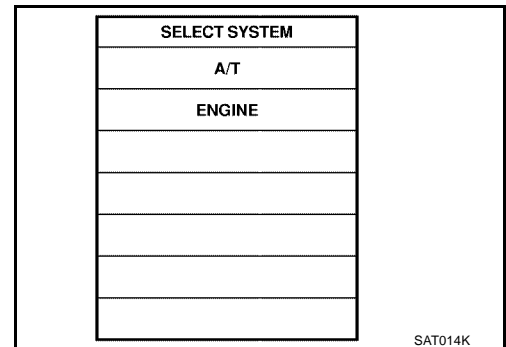

Diagnostic Procedure

ECS00AXV

1. CHECK CAN COMMUNICATION LINE

Perform the self-diagnosis. Refer to [AT-87, "SELF-DIAGNOSTIC RESULT MODE"](#).

Is a malfunction in the CAN communication indicated in the results?

- YES >> Check CAN communication line. Refer to [AT-97, "DTC U1000 CAN COMMUNICATION LINE"](#).
NO >> GO TO 2.

DTC P0725 ENGINE SPEED SIGNAL

2. CHECK DTC WITH TCM

With CONSULT-II

1. Start engine.
2. Select "ECU INPUT SIGNALS" in "DATA MONITOR" mode for "A/T" with CONSULT-II.
3. While monitoring engine speed, check for engine speed change corresponding to wide-open throttle position signal.

Item name	Condition	Display value (rpm)
ENGINE SPEED	Engine running	Closely matches the tachometer reading.

DATA MONITOR	
MONITOR	NO. DTC
W/O THL POS	OFF
BRAKE SW	OFF
ENGINE SPEED	0 rpm
TURBINE REV	0 rpm
OUTPUT REV	0 rpm

		▼	
RECORD			
MODE	BACK	LIGHT	COPY

PCIA0041E

OK or NG

- OK >> GO TO 3.
- NG >> Check the ignition signal circuit.
 - Refer to [EC-596, "IGNITION SIGNAL"](#).

3. CHECK DTC

Perform "DTC Confirmation Procedure".

- Refer to [AT-114, "DTC Confirmation Procedure"](#).

OK or NG

- OK >> **INSPECTION END**
- NG >> GO TO 4.

4. CHECK TCM POWER SUPPLY AND GROUND CIRCUIT

Check TCM power supply and ground circuit. Refer to [AT-174, "MAIN POWER SUPPLY AND GROUND CIRCUIT"](#).

OK or NG

- OK >> GO TO 5.
- NG >> Repair or replace damaged parts.

5. DETECT MALFUNCTIONING ITEM

Check the following items:

- The A/T assembly harness connector pin terminals for damage or loose connection with harness connector.

OK or NG

- OK >> Replace the control valve with TCM. Refer to [AT-250, "Control Valve With TCM and A/T Fluid Temperature Sensor 2"](#).
- NG >> Repair or replace damaged parts.

DTC P0740 TORQUE CONVERTER CLUTCH SOLENOID VALVE

DTC P0740 TORQUE CONVERTER CLUTCH SOLENOID VALVE

PF3:31940

Description

ECS00AXW

- The torque converter clutch solenoid valve is activated, with the gear in D4 , D5 by the TCM in response to signals sent from the vehicle speed sensor and accelerator pedal position sensor (throttle position sensor). Torque converter clutch piston operation will then be controlled.
- Lock-up operation, however, is prohibited when A/T fluid temperature is too low.
- When the accelerator pedal is depressed (less than 1/8) in lock-up condition, the engine speed should not change abruptly. If there is a big jump in engine speed, there is no lock-up.

CONSULT-II Reference Value

ECS00AXX

Item name	Condition	Display value (Approx.) (A)
TCC SOLENOID	When performing slip lock-up	0.2 - 0.4
	When performing lock-up	0.4 - 0.6

On Board Diagnosis Logic

ECS00AXY

- This is an OBD-II self-diagnostic item.
- Diagnostic trouble code "P0740 TCC SOLENOID/CIRC" with CONSULT-II is detected under the following conditions.
 - When TCM detects an improper voltage drop when it tries to operate the solenoid valve.
 - When TCM detects as irregular by comparing target value with monitor value.

Possible Cause

ECS00AXZ

- Torque converter clutch solenoid valve
- Harness or connectors
(The solenoid circuit is open or shorted.)

DTC Confirmation Procedure

ECS00AY0

CAUTION:

Always drive vehicle at a safe speed.

NOTE:

If "DTC Confirmation Procedure" has been previously performed, always turn ignition switch "OFF" and wait at least 10 seconds before performing the next test.

After the repair, perform the following procedure to confirm the malfunction is eliminated.

WITH CONSULT-II

1. Turn ignition switch "ON". (Do not start engine.)
2. Select "DATA MONITOR" mode for "ENGINE" with CONSULT-II.
3. Start engine and maintain the following conditions for at least 5 consecutive seconds.

VHCL SPEED SE: 80 km/h (50 MPH) or more

ACCELE POS: 0.5/8 - 1.0/8

SELECTOR LEVER: "D" position

Driving location: Driving the vehicle uphill (increased engine load) will help maintain the driving conditions required for this test.

4. If DTC is detected go to [AT-117, "Diagnostic Procedure"](#).

WITH GST

Follow the procedure "With CONSULT-II".

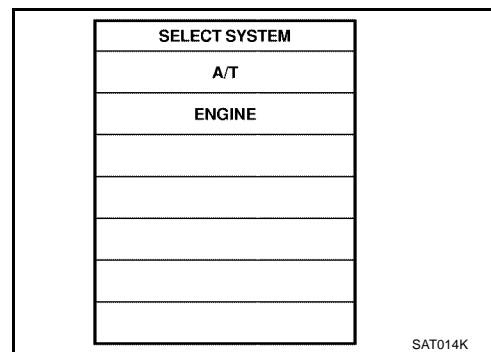

DTC P0740 TORQUE CONVERTER CLUTCH SOLENOID VALVE

ECS00AY1

Diagnostic Procedure

1. CHECK INPUT SIGNAL

With CONSULT-II

1. Turn ignition switch ON.
2. Select "MAIN SIGNALS" in "DATA MONITOR" mode for "A/T" with CONSULT-II.
3. Start engine.
4. Read out the value of "TCC SOLENOID" while driving.

DATA MONITOR	
MONITOR	NO DTC
TCC SOLENOID	XXXX
LINE PRES SOL	XXXX
I/C SOLENOID	XXXX
FR/B SOLENOID	XXXX
D/C SOLENOID	XXXX
HLR/C SOL	XXXX
	▽
	RECORD
MODE	BACK
LIGHT	COPY

SCIA4793E

Item name	Condition	Display value (Approx.)
TCC SOLENOID	When performing slip lock-up	0.2 - 0.4 A
	When performing lock-up	0.4 - 0.6 A

OK or NG

- OK >> GO TO 4.
NG >> GO TO 2.

2. CHECK TCM POWER SUPPLY AND GROUND CIRCUIT

Check TCM power supply and ground circuit. Refer to [AT-174, "MAIN POWER SUPPLY AND GROUND CIRCUIT"](#).

OK or NG

- OK >> GO TO 3.
NG >> Repair or replace damaged parts.

3. DETECT MALFUNCTIONING ITEM

Check the following items:

- The A/T assembly harness connector pin terminals for damage or loose connection with harness connector.

OK or NG

- OK >> Replace the control valve with TCM. Refer to [AT-250, "Control Valve With TCM and A/T Fluid Temperature Sensor 2"](#).
NG >> Repair or replace damaged parts.

4. CHECK DTC

Perform "DTC Confirmation Procedure".

- Refer to [AT-116, "DTC Confirmation Procedure"](#).

OK or NG

- OK >> **INSPECTION END**
NG >> GO TO 2.

DTC P0744 A/T TCC S/V FUNCTION (LOCK-UP)

DTC P0744 A/T TCC S/V FUNCTION (LOCK-UP)

PF3:31940

Description

ECS00AY2

This malfunction is detected when the A/T does not shift into 5th gear position or the torque converter clutch does not lock-up as instructed by the TCM. This is not only caused by electrical malfunction (circuits open or shorted) but also by mechanical malfunction such as control valve sticking, improper solenoid valve operation, etc.

CONSULT-II Reference Value

ECS00AY3

Item name	Condition	Display value (Approx.) (A)
TCC SOLENOID	When performing slip lock-up	0.2 - 0.4
	When performing lock-up	0.4 - 0.6

On Board Diagnosis Logic

ECS00AY4

- This is an OBD-II self-diagnostic item.
- Diagnostic trouble code "P0744 A/T TCC S/V FNCTN" with CONSULT-II is detected under the following conditions.
 - When A/T cannot perform lock-up even if electrical circuit is good.
 - When TCM detects as irregular by comparing difference value with slip rotation.

Possible Cause

ECS00AY5

- Harness or connectors
(The solenoid circuit is open or shorted.)
- Torque converter clutch solenoid valve
- Hydraulic control circuit

DTC Confirmation Procedure

ECS00AY6

CAUTION:

Always drive vehicle at a safe speed.

NOTE:

If "DTC Confirmation Procedure" has been previously performed, always turn ignition switch "OFF" and wait at least 10 seconds before performing the next test.

After the repair, perform the following procedure to confirm the malfunction is eliminated.

WITH CONSULT-II

1. Start engine and Select "TCC S/V FNCTN CHECK" of "DTC WORK SUPPORT" mode for "A/T" with CONSULT-II and touch "START".
2. Accelerate vehicle to more than 80 km/h (50 MPH) and maintain the following condition continuously until "TESTING" has turned to "COMPLETE". (It will take approximately 30 seconds after "TESTING" shows.)
ACCELE POSI: More than 1.0/8 (at all times during step 4)
TCC SOLENOID: 0.4 - 0.6 A
Selector lever: "D" position
[Reference speed: Constant speed of more than 80 km/h (50 MPH)]

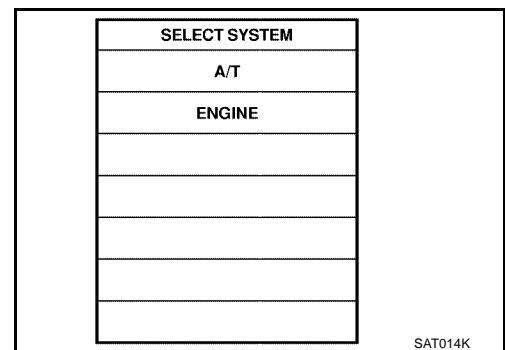

- Make sure "GEAR" shows "5".
 - For shift schedule, refer to [AT-62, "Vehicle Speed When Performing and Releasing Complete Lock-up"](#).
 - If "TESTING" does not appear on CONSULT-II for a long time, select "SELF-DIAG RESULTS". In case a 1st trip DTC other than P0744 is shown, refer to applicable "TROUBLE DIAGNOSIS FOR DTC".
3. Make sure that "OK" is displayed. (If "NG" is displayed, refer to "DIAGNOSTIC PROCEDURE".)
Refer to [AT-119, "Diagnostic Procedure"](#).
Refer to shift schedule, [AT-62, "Vehicle Speed When Performing and Releasing Complete Lock-up"](#).

DTC P0744 A/T TCC S/V FUNCTION (LOCK-UP)

WITH GST

Follow the procedure "With CONSULT-II".

Diagnostic Procedure

ECS00AY7

1. CHECK INPUT SIGNAL

With CONSULT-II

1. Turn ignition switch ON.
2. Select "MAIN SIGNALS" in "DATA MONITOR" mode for "A/T" with CONSULT-II.
3. Start the engine.
4. Read out the value of "TCC SOLENOID" while driving.

DATA MONITOR	
MONITOR	NO DTC
TCC SOLENOID	XXXX
LINE PRES SOL	XXXX
I/C SOLENOID	XXXX
FR/B SOLENOID	XXXX
D/C SOLENOID	XXXX
HLR/C SOL	XXXX
	▽
	RECORD
MODE	BACK
LIGHT	COPY

SCIA4793E

Item name	Condition	Display value (Approx.)
TCC SOLENOID	When performing slip lock-up	0.2 - 0.4 A
	When performing lock-up	0.4 - 0.6 A

OK or NG

- OK >> GO TO 4.
- NG >> GO TO 2.

2. CHECK TCM POWER SUPPLY AND GROUND CIRCUIT

Check TCM power supply and ground circuit. Refer to [AT-174, "MAIN POWER SUPPLY AND GROUND CIRCUIT"](#).

OK or NG

- OK >> GO TO 3.
- NG >> Repair or replace damaged parts.

3. DETECT MALFUNCTIONING ITEM

Check the following items:

- The A/T assembly harness connector pin terminals for damage or loose connection with harness connector.

OK or NG

- OK >> Replace the control valve with TCM. Refer to [AT-250, "Control Valve With TCM and A/T Fluid Temperature Sensor 2"](#).
- NG >> Repair or replace damaged parts.

4. CHECK DTC

Perform "DTC Confirmation Procedure".

- Refer to [AT-118, "DTC Confirmation Procedure"](#).

OK or NG

- OK >> **INSPECTION END**
- NG >> GO TO 2.

DTC P0745 LINE PRESSURE SOLENOID VALVE

DTC P0745 LINE PRESSURE SOLENOID VALVE

PFPP:31940

Description

ECS00AY8

The line pressure solenoid valve regulates the oil pump discharge pressure to suit the driving condition in response to a signal sent from the TCM.

The line pressure duty cycle value is not consistent when the closed throttle position signal is “ON”. To confirm the line pressure duty cycle at low pressure, the accelerator (throttle) should be open until the closed throttle position signal is “OFF”.

CONSULT-II Reference Value

ECS00AY9

Item name	Condition	Display value (Approx.) (A)
LINE PRES SOL	During driving	0.2 - 0.6

On Board Diagnosis Logic

ECS00AYA

- This is an OBD-II self-diagnostic item.
- Diagnostic trouble code “P0745 L/PRESS SOL/CIRC” with CONSULT-II is detected under the following conditions.
 - When TCM detects an improper voltage drop when it tries to operate the solenoid valve.
 - When TCM detects as irregular by comparing target value with monitor value.

Possible Cause

ECS00AYB

- Harness or connectors
(The solenoid circuit is open or shorted.)
- Line pressure solenoid valve

DTC Confirmation Procedure

ECS00AYC

NOTE:

If “DTC Confirmation Procedure” has been previously performed, always turn ignition switch “OFF” and wait at least 10 seconds before performing the next test.

After the repair, perform the following procedure to confirm the malfunction is eliminated.

④ WITH CONSULT-II

1. Turn ignition switch “ON” and select “DATA MONITOR” mode for “ENGINE” with CONSULT-II.
2. Engine start and wait at least 5 second.
3. If DTC is detected, go to [AT-121, "Diagnostic Procedure"](#) .

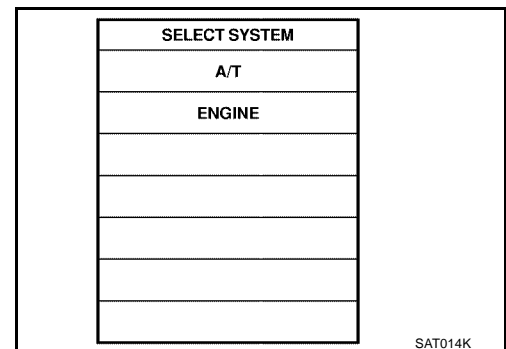

④ WITH GST

Follow the procedure “With CONSULT-II”.

DTC P0745 LINE PRESSURE SOLENOID VALVE

ECS00CC3

Diagnostic Procedure

1. CHECK INPUT SIGNAL

With CONSULT-II

1. Turn ignition switch ON.
2. Select "MAIN SIGNALS" in "DATA MONITOR" mode for "A/T" with CONSULT-II.
3. Start the engine.
4. Read out the value of "LINE PRES SOL" while driving.

DATA MONITOR	
MONITOR	NO DTC
TCC SOLENOID	XXXX
LINE PRES SOL	XXXX
I/C SOLENOID	XXXX
FR/B SOLENOID	XXXX
D/C SOLENOID	XXXX
HLR/C SOL	XXXX
	▽
	RECORD
MODE	BACK
LIGHT	COPY

SCIA4793E

Item name	Condition	Display value (Approx.)
LINE PRES SOL	During driving	0.2 - 0.6 A

OK or NG

- OK >> GO TO 4.
NG >> GO TO 2.

2. CHECK TCM POWER SUPPLY AND GROUND CIRCUIT

Check TCM power supply and ground circuit. Refer to [AT-174, "MAIN POWER SUPPLY AND GROUND CIRCUIT"](#).

OK or NG

- OK >> GO TO 3.
NG >> Repair or replace damaged parts.

3. DETECT MALFUNCTIONING ITEM

Check the following items:

- The A/T assembly harness connector pin terminals for damage or loose connection with harness connector.

OK or NG

- OK >> Replace the control valve with TCM. Refer to [AT-250, "Control Valve With TCM and A/T Fluid Temperature Sensor 2"](#).
- NG >> Repair or replace damaged parts.

4. CHECK DTC

Perform "DTC Confirmation Procedure".

- Refer to [AT-120, "DTC Confirmation Procedure"](#).

OK or NG

- OK >> **INSPECTION END**
NG >> GO TO 2.

DTC P1702 TRANSMISSION CONTROL MODULE (RAM)

DTC P1702 TRANSMISSION CONTROL MODULE (RAM)

PF3:31036

Description

ECS00AYE

The TCM consists of a microcomputer and connectors for signal input and output and for power supply. The TCM controls the A/T.

On Board Diagnosis Logic

ECS00AYF

- This is not an OBD-II self-diagnostic item.
- Diagnostic trouble code "P1702 TCM-RAM" with CONSULT-II is detected when TCM memory RAM is malfunctioning.

Possible Cause

ECS00AYG

TCM.

DTC Confirmation Procedure

ECS00AYH

NOTE:

If "DTC Confirmation Procedure" has been previously performed, always turn ignition switch "OFF" and wait at least 10 seconds before performing the next test.

After the repair, perform the following procedure to confirm the malfunction is eliminated.

WITH CONSULT-II

1. Turn ignition switch "ON". (Do not start engine.)
2. Select "DATA MONITOR" mode for "A/T" with CONSULT-II.
3. Start engine.
4. Run engine for at least 2 consecutive seconds at idle speed.
5. If DTC is detected, go to [AT-122, "Diagnostic Procedure"](#).

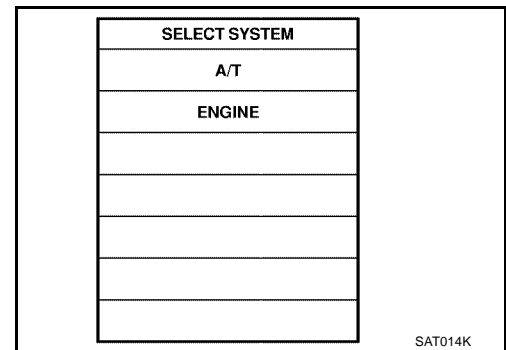

Diagnostic Procedure

ECS00AYI

1. CHECK DTC

With CONSULT-II

1. Turn ignition switch "ON". (Do not start engine.)
2. Select "SELF-DIAG RESULTS" mode for "A/T" with CONSULT-II.
3. Touch "ERASE".
4. Turn ignition switch "OFF" and wait at least 10 seconds.
5. Perform "DTC confirmation procedure", [AT-122, "DTC Confirmation Procedure"](#).

Is the "TCM-RAM" displayed again?

YES >> Replace the control valve with TCM. Refer to [AT-250, "CONTROL VALVE WITH TCM REMOVAL AND INSTALLATION"](#).

NO >> **INSPECTION END**

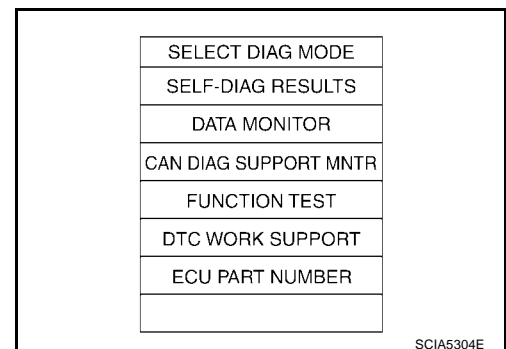

DTC P1703 TRANSMISSION CONTROL MODULE (ROM)

DTC P1703 TRANSMISSION CONTROL MODULE (ROM)

PF3:31036

Description

ECS00AYJ

The TCM consists of a microcomputer and connectors for signal input and output and for power supply. The TCM controls the A/T.

On Board Diagnosis Logic

ECS00AYK

- This is not an OBD-II self-diagnostic item.
- Diagnostic trouble code "P1703 TCM-ROM" with CONSULT-II is detected when TCM memory ROM is malfunctioning.

Possible Cause

ECS00AYL

TCM.

DTC Confirmation Procedure

ECS00AYM

NOTE:

If "DTC Confirmation Procedure" has been previously performed, always turn ignition switch "OFF" and wait at least 10 seconds before performing the next test.

After the repair, perform the following procedure to confirm the malfunction is eliminated.

WITH CONSULT-II

1. Turn ignition switch to "ON". (Do not start engine.)
2. Select "DATA MONITOR" mode for A/T with CONSULT-II.
3. Start engine.
4. Run engine for at least 2 consecutive seconds at idle speed.
5. If DTC is detected, go to [AT-123, "Diagnostic Procedure"](#).

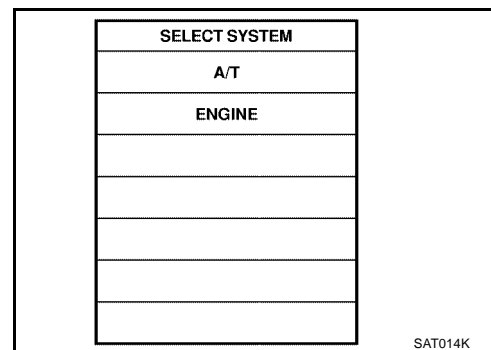

Diagnostic Procedure

ECS00AYN

1. CHECK DTC

With CONSULT-II

1. Turn ignition switch "ON". (Do not start engine.)
2. Select "SELF-DIAG RESULTS" mode for "A/T" with CONSULT-II.
3. Touch "ERASE".
4. Turn ignition switch "OFF" and wait at least 10 seconds.
5. Perform "DTC confirmation procedure", [AT-123, "DTC Confirmation Procedure"](#).

Is the "TCM-ROM" displayed again?

YES >> Replace the control valve with TCM. Refer to [AT-250, "CONTROL VALVE WITH TCM REMOVAL AND INSTALLATION"](#).

NO >> **INSPECTION END**

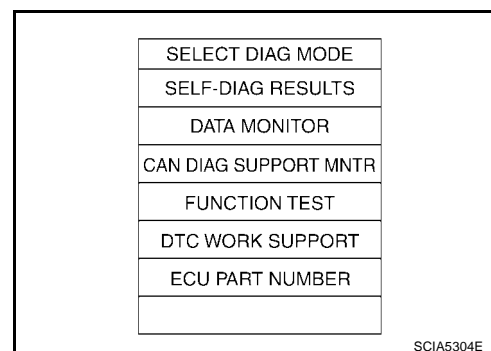

DTC P1705 THROTTLE POSITION SENSOR

DTC P1705 THROTTLE POSITION SENSOR

PFP:22620

Description

ECS00AYO

Electric throttle control actuator consists of throttle control motor, accelerator pedal position sensor, throttle position sensor, etc. The actuator sends a signal to the ECM, and ECM sends signals to TCM with CAN communication.

CONSULT-II Reference Value

ECS00AYP

Item name	Condition	Display value (Approx.)
ACCELE POSI	Released accelerator pedal.	0.0/8
	Fully depressed accelerator pedal.	8/8
THROTTLE POSI	Released accelerator pedal.	0.0/8
	Fully depressed accelerator pedal.	8/8

On Board Diagnosis Logic

ECS00AYQ

- This is not an OBD-II self-diagnostic item.
- Diagnostic trouble code "P1705 TP SEN/CIRC A/T" with CONSULT-II is detected when TCM does not receive the proper accelerator pedal position signals (input by CAN communication) from ECM.

Possible Cause

ECS00AYR

Harness or connectors
(The sensor circuit is open or shorted.)

DTC Confirmation Procedure

ECS00AYS

NOTE:

If "DTC Confirmation Procedure" has been previously performed, always turn ignition switch "OFF" and wait at least 10 seconds before performing the next test.

After the repair, perform the following procedure to confirm the malfunction is eliminated.

④ WITH CONSULT-II

1. Turn ignition switch "ON". (Do not start engine.)
2. Select "DATA MONITOR" mode for "A/T" with CONSULT-II.
3. Start engine and let it idle for 1 second.
4. If DTC is detected, go to [AT-125, "Diagnostic Procedure"](#).

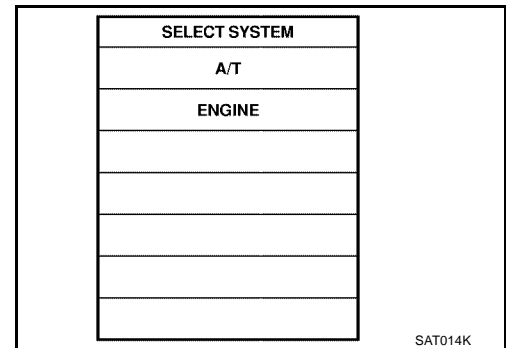

DTC P1705 THROTTLE POSITION SENSOR

ECS00CC4

Diagnostic Procedure

1. CHECK CAN COMMUNICATION LINE

Perform the self-diagnosis. Refer to [AT-87, "SELF-DIAGNOSTIC RESULT MODE"](#).

Is a malfunction in the CAN communication indicated in the results?

- YES >> Check CAN communication line. Refer to [AT-97, "DTC U1000 CAN COMMUNICATION LINE"](#).
NO >> GO TO 2.

2. CHECK DTC WITH TCM

With CONSULT-II

- Turn ignition switch ON. (Do not start engine.)
- Select "ECU INPUT SIGNALS" in "DATA MONITOR" mode for "A/T" with CONSULT-II.
- Depress accelerator pedal and read out the value of "ACCELE POSI" and "THROTTLE POSI".

Item name	Condition	Display value (Approx.)
ACCELE POSI	Released accelerator pedal.	0.0/8
	Fully depressed accelerator pedal.	8/8
THROTTLE POSI	Released accelerator pedal.	0.0/8
	Fully depressed accelerator pedal.	8/8

DATA MONITOR

MONITOR	NO DTC
ACCELE POSI	0.0/8
THROTTLE POSI	0.0/8
CLSD THL POS	ON
W/O THL POS	OFF
BRAKE SW	OFF

MODE BACK LIGHT COPY

PCIA0070E

- Select "SELF-DIAG RESULTS" mode for "A/T" with CONSULT-II. Refer to [AT-87, "SELF-DIAGNOSTIC RESULT MODE"](#).

OK or NG

- OK >> GO TO 4.
NG >> GO TO 3.

3. CHECK DTC WITH ECM

With CONSULT-II

- Turn ignition switch ON. (Do not start engine.)
- Select "SELF-DIAG RESULTS" mode for "ENGINE" with CONSULT-II. Refer to [EC-127, "SELF-DIAG RESULTS MODE"](#).

OK or NG

- OK >> GO TO 4.
NG >> Check the DTC detected item. Refer to [EC-127, "SELF-DIAG RESULTS MODE"](#).
- If CAN communication line is detected, go to [AT-97, "DTC U1000 CAN COMMUNICATION LINE"](#).

SELECT SYSTEM

A/T
ENGINE

SAT014K

4. CHECK DTC

Perform "DTC Confirmation Procedure".

- Refer to [AT-124, "DTC Confirmation Procedure"](#).

OK or NG

- OK >> **INSPECTION END**
NG >> GO TO 5.

DTC P1705 THROTTLE POSITION SENSOR

5. CHECK TCM POWER SUPPLY AND GROUND CIRCUIT

Check TCM power supply and ground circuit. Refer to [AT-174, "MAIN POWER SUPPLY AND GROUND CIRCUIT"](#) .

OK or NG

- OK >> GO TO 6.
- NG >> Repair or replace damaged parts.

6. DETECT MALFUNCTIONING ITEM

Check the following items:

- The A/T assembly harness connector pin terminals for damage or loose connection with harness connector.

OK or NG

- OK >> Replace the control valve with TCM. Refer to [AT-250, "Control Valve With TCM and A/T Fluid Temperature Sensor 2"](#) .
- NG >> Repair or replace damaged parts.

DTC P1710 A/T FLUID TEMPERATURE SENSOR CIRCUIT

DTC P1710 A/T FLUID TEMPERATURE SENSOR CIRCUIT

PF3:31940

Description

ECS00AYU

The A/T fluid temperature sensor detects the A/T fluid temperature and sends a signal to the TCM.

CONSULT-II Reference Value

ECS00AYV

Item name	Condition °C (°F)	Display value (Approx.) V
ATF TEMP SE 1	0 (32) - 20 (68) - 80 (176)	2.2 - 1.8 - 0.6
ATF TEMP SE 2		2.2 - 1.7 - 0.45

On Board Diagnosis Logic

ECS00AYW

- This is an OBD-II self-diagnostic item.
- Diagnostic trouble code "ATF TEMP SEN/CIRC" with CONSULT-II is detected when TCM receives an excessively low or high voltage from the sensor.

Possible Cause

ECS00AYX

- Harness or connectors
(The sensor circuit is open or shorted.)
- A/T fluid temperature sensors 1, 2

DTC Confirmation Procedure

ECS00AYY

CAUTION:

Always drive vehicle at a safe speed.

NOTE:

If "DTC Confirmation Procedure" has been previously performed, always turn ignition switch "OFF" and wait at least 10 seconds before performing the next test.

After the repair, perform the following procedure to confirm the malfunction is eliminated.

WITH CONSULT-II

1. Turn ignition switch "ON". (Do not start engine.)
2. Select "DATA MONITOR" mode for "ENGINE" with CONSULT-II.
3. Start engine and maintain the following conditions for at least 10 minutes (Total). (It is not necessary to maintain continuously.)
VHCL SPEED SE: 10 km/h (6 MPH) or more
THRTL POS SEN: More than 1.0/8
Selector lever: "D" position
4. If DTC is detected, go to [AT-129, "Diagnostic Procedure"](#).

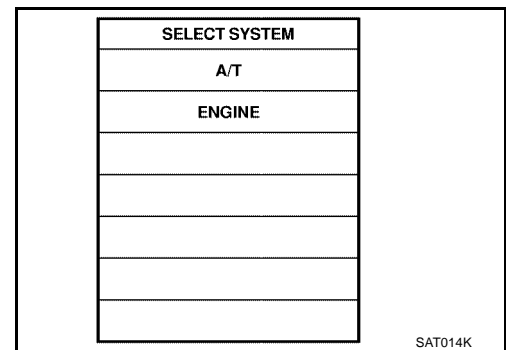

WITH GST

Follow the procedure "With CONSULT-II".

DTC P1710 A/T FLUID TEMPERATURE SENSOR CIRCUIT

Wiring Diagram — AT — FTS

ECS00CC5

AT-FTS-01

: DETECTABLE LINE FOR DTC
 : NON-DETECTABLE LINE FOR DTC

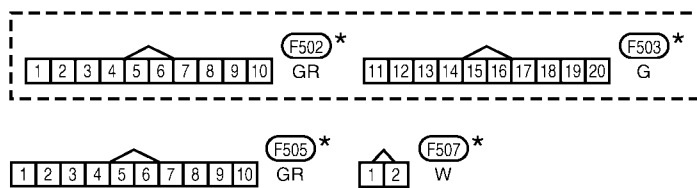
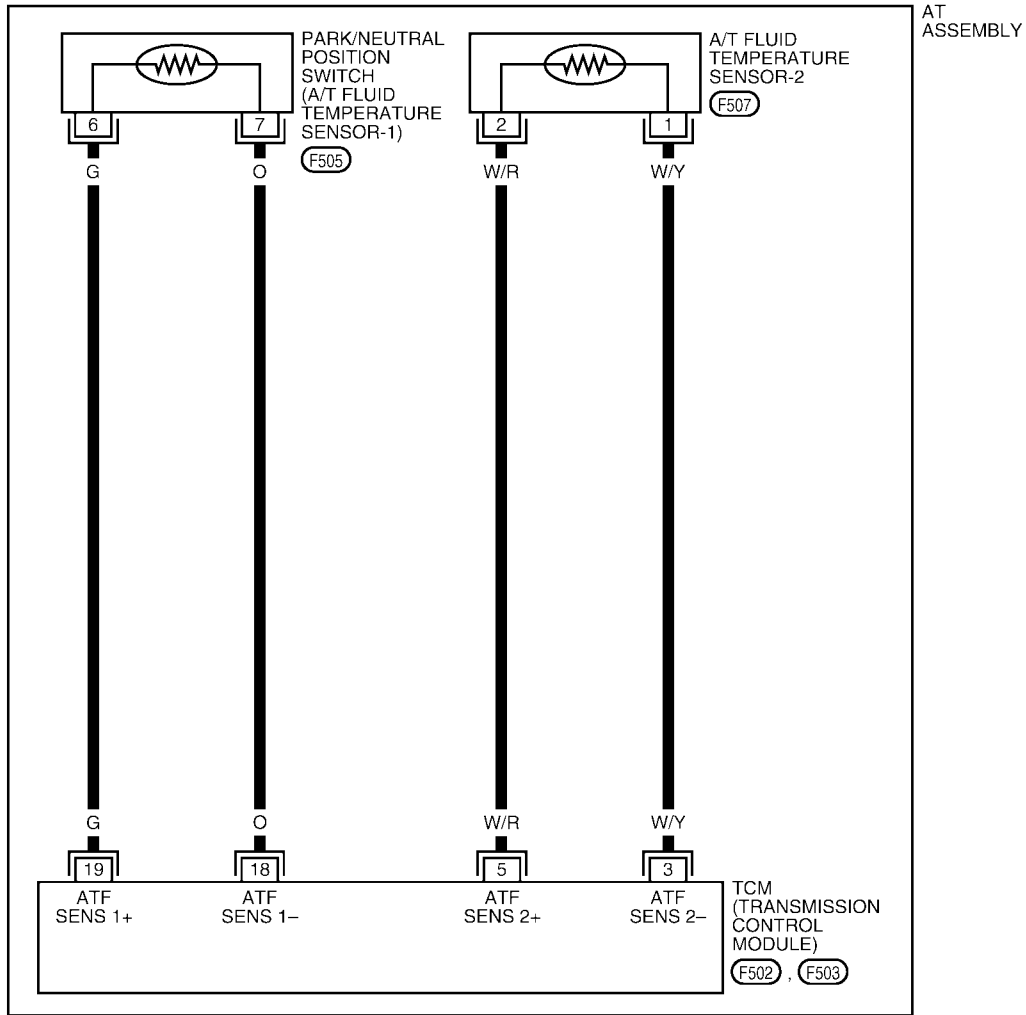

*: THIS CONNECTOR IS NOT SHOWN IN "HARNESS LAYOUT" OF PG SECTION.

BCWA0323E

DTC P1710 A/T FLUID TEMPERATURE SENSOR CIRCUIT

ECS00CC6

Diagnostic Procedure

1. CHECK A/T FLUID TEMPERATURE SENSOR 1 SIGNAL

With CONSULT-II

- Start engine.
- Select "ECU INPUT SIGNALS" in "DATA MONITOR" mode for "A/T" with CONSULT-II.
- Read out the value of "ATF TEMP SE 1".

Item name	Condition °C (°F)	Display value (Approx.)
ATF TEMP SE 1	0 (32) - 20 (68) - 80 (176)	2.2 - 1.8 - 0.6 V

OK or NG

- OK >> GO TO 2.
NG >> GO TO 3.

DATA MONITOR	
MONITOR	NO. DTC
OUTPUT REV	0 rpm
ATF TEMP SE 1	1.84 v
ATF TEMP SE 2	1.72 v
BATTERY BOLT	11.5 v
ATF PRES SW 1	OFF

Δ	▽
RECORD	
MODE	BACK LIGHT COPY

PCIA0039E

2. CHECK A/T FLUID TEMPERATURE SENSOR 2 SIGNAL

With CONSULT-II

- Start engine.
- Select "ECU INPUT SIGNALS" in "DATA MONITOR" mode for "A/T" with CONSULT-II.
- Read out the value of "ATF TEMP SE 2".

Item name	Condition °C (°F)	Display value (Approx.)
ATF TEMP SE 2	0 (32) - 20 (68) - 80 (176)	2.2 - 1.7 - 0.45 V

OK or NG

- OK >> GO TO 8.
NG >> GO TO 5.

DATA MONITOR	
MONITOR	NO. DTC
OUTPUT REV	0 rpm
ATF TEMP SE 1	1.84 v
ATF TEMP SE 2	1.72 v
BATTERY BOLT	11.5 v
ATF PRES SW 1	OFF

Δ	▽
RECORD	
MODE	BACK LIGHT COPY

PCIA0039E

3. CHECK A/T FLUID TEMPERATURE SENSOR 1

Check A/T fluid temperature sensor 1. Refer to [AT-131, "A/T FLUID TEMPERATURE SENSOR 1"](#).

OK or NG

- OK >> GO TO 4.
NG >> Replace the control valve with TCM. Refer to [AT-250, "Control Valve With TCM and A/T Fluid Temperature Sensor 2"](#).

4. CHECK SUB-HARNESS

- Disconnect park/neutral position switch connector and TCM connector.
- Check continuity between park/neutral position switch connector terminals and TCM connector terminals.

Item	Connector	Terminal (Wire color)	Continuity
Park/neutral position switch connector	F505	6 (G)	Yes
TCM connector	F503	19 (G)	
Park/neutral position switch connector	F505	7 (O)	Yes
TCM connector	F503	18 (O)	

- If OK, check harness for short to ground and short to power.

OK or NG

- OK >> GO TO 7.
NG >> Replace open circuit or short to ground and short to power in harness or connectors.

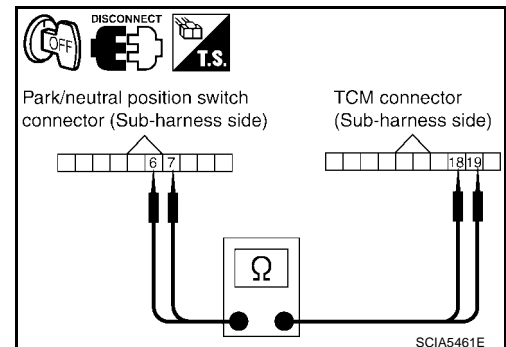

DTC P1710 A/T FLUID TEMPERATURE SENSOR CIRCUIT

5. CHECK A/T FLUID TEMPERATURE SENSOR 2

Check A/T fluid temperature sensor 2. Refer to [AT-131, "A/T FLUID TEMPERATURE SENSOR 2"](#) .

OK or NG

OK >> GO TO 6.

NG >> Replace the A/T fluid temperature sensor 2. Refer to [AT-258, "A/T FLUID TEMPERATURE SENSOR 2 REMOVAL AND INSTALLATION"](#) .

6. CHECK TERMINAL CORD ASSEMBLY

1. Disconnect A/T fluid temperature sensor 2 connector and TCM connector.
2. Check continuity between A/T fluid temperature sensor 2 connector terminals and TCM connector terminals.

Item	Connector	Terminal (Wire color)	Continuity
A/T fluid temperature sensor 2 connector	F507	1 (W/Y)	Yes
TCM connector	F502	3 (W/Y)	
A/T fluid temperature sensor 2 connector	F507	2 (W/R)	Yes
TCM connector	F502	5 (W/R)	

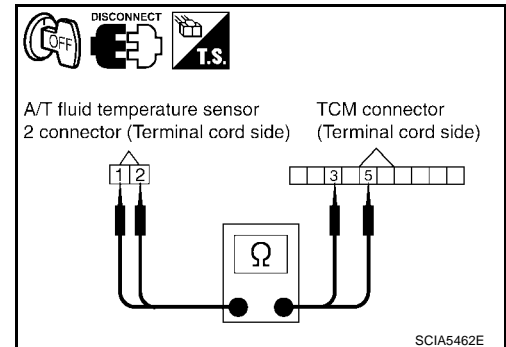

3. If OK, check harness for short to ground and short to power.

OK or NG

OK >> GO TO 7.

NG >> Replace open circuit or short to ground and short to power in harness or connectors.

7. CHECK TCM POWER SUPPLY AND GROUND CIRCUIT

1. Check TCM power supply and ground circuit. Refer to [AT-174, "MAIN POWER SUPPLY AND GROUND CIRCUIT"](#) .
2. Reinstall any part removed.

OK or NG

OK >> Replace the control valve with TCM. Refer to [AT-250, "Control Valve With TCM and A/T Fluid Temperature Sensor 2"](#) .

NG >> Repair or replace damaged parts.

8. CHECK DTC

Perform "DTC Confirmation Procedure".

- Refer to [AT-127, "DTC Confirmation Procedure"](#) .

OK or NG

OK >> **INSPECTION END**

NG >> GO TO 1.

DTC P1710 A/T FLUID TEMPERATURE SENSOR CIRCUIT

ECS00CC7

Component Inspection

A/T FLUID TEMPERATURE SENSOR 1

1. Remove control valve with TCM. Refer to [AT-250, "Control Valve With TCM and A/T Fluid Temperature Sensor 2"](#) .
2. Check resistance between terminals.

Name	Connector	Terminal	Temperature °C (°F)	Resistance (Approx.) (kΩ)
A/T fluid temperature sensor 1	F505	6 - 7	0 (32)	15
			20 (68)	6.5
			80 (176)	0.9

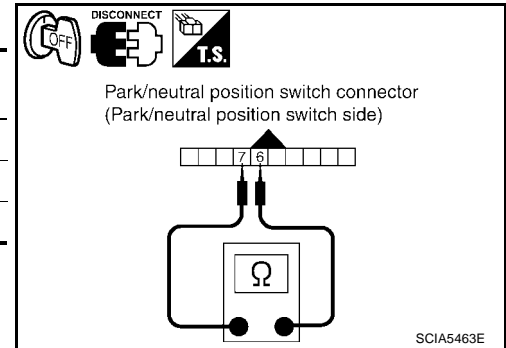

3. If NG, replace the control valve with TCM. Refer to [AT-250, "Control Valve With TCM and A/T Fluid Temperature Sensor 2"](#) .

A/T FLUID TEMPERATURE SENSOR 2

1. Remove A/T fluid temperature sensor 2. Refer to [AT-258, "A/T FLUID TEMPERATURE SENSOR 2 REMOVAL AND INSTALLATION"](#) .
2. Check resistance between terminals.

Name	Connector	Terminal	Temperature °C (°F)	Resistance (Approx.) (kΩ)
A/T fluid temperature sensor 2	F507	1 - 2	0 (32)	10
			20 (68)	4
			80 (176)	0.5

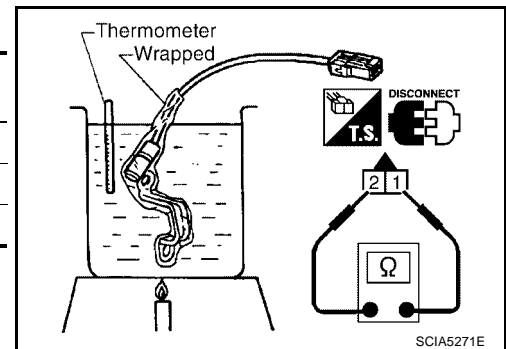

3. If NG, replace the A/T fluid temperature sensor 2. Refer to [AT-258, "A/T FLUID TEMPERATURE SENSOR 2 REMOVAL AND INSTALLATION"](#) .

A
B
AT
D
E
F
G
H
I
J
K
L
M

DTC P1716 TURBINE REVOLUTION SENSOR

DTC P1716 TURBINE REVOLUTION SENSOR

PPF:31935

Description

ECS00AZ1

The turbine revolution sensor detects input shaft rpm (revolutions per minute). It is located on the input side of the automatic transmission. Monitors revolution of sensor 1 and sensor 2 for non-standard conditions.

CONSULT-II Reference Value

ECS00AZ2

Item name	Condition	Display value (rpm)
TURBINE REV	During driving (lock-up ON)	Approximately matches the engine speed.

On Board Diagnosis Logic

ECS00AZ3

- This is an OBD-II self-diagnostic item.
- Diagnostic trouble code "P1716 TURBINE REV S/CIRC" with CONSULT-II is detected under the following conditions.
 - When TCM does not receive the proper voltage signal from the sensor.
 - When TCM detects an irregularity only at position of 4th gear for turbine revolution sensor 2.

Possible Cause

ECS00AZ4

- Harness or connectors
(The sensor circuit is open or shorted.)
- Turbine revolution sensor 1, 2

DTC Confirmation Procedure

ECS00AZ5

CAUTION:

Always drive vehicle at a safe speed.

NOTE:

If "DTC Confirmation Procedure" has been previously performed, always turn ignition switch "OFF" and wait at least 10 seconds before performing the next test.

After the repair, perform the following procedure to confirm the malfunction is eliminated.

WITH CONSULT-II

1. Turn ignition switch "ON". (Do not start engine.)
2. Select "DATA MONITOR" mode for "A/T" with CONSULT-II.
3. Start engine and maintain the following conditions for at least 5 consecutive seconds.

VHCL SPEED SE: 40 km/h (25 MPH) or more

ENGINE SPEED: 1,500 rpm or more

ACCELE POS: 0.5/8 or more

Selector lever: "D" position

Gear position (Turbine revolution sensor 1): 4th or 5th position

Gear position (Turbine revolution sensor 2): All position

Driving location: Driving the vehicle uphill (increased engine load) will help maintain the driving conditions required for this test.

4. If DTC is detected, go to [AT-133, "Diagnostic Procedure"](#).

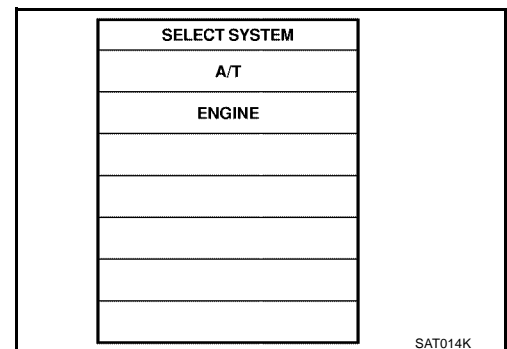

WITH GST

Follow the procedure "With CONSULT-II".

DTC P1716 TURBINE REVOLUTION SENSOR

ECS00CC8

Diagnostic Procedure

1. CHECK INPUT SIGNAL

With CONSULT-II

1. Start engine.
2. Select "ECU INPUT SIGNALS" in "DATA MONITOR" mode for "A/T" with CONSULT-II.
3. Vehicle start and read out the value of "TURBINE REV".

Item name	Condition	Display value (rpm)
TURBINE REV	During driving (lock-up ON)	Approximately matches the engine speed.

OK or NG

- OK >> GO TO 4.
NG >> GO TO 2.

DATA MONITOR	
MONITOR	NO. DTC
W/O THL POS	OFF
BRAKE SW	OFF
ENGINE SPEED	0 rpm
TURBINE REV	0 rpm
OUTPUT REV	0 rpm
▼	
RECORD	
MODE	BACK
LIGHT	COPY

PCIA0041E

2. CHECK TCM POWER SUPPLY AND GROUND CIRCUIT

Check TCM power supply and ground circuit. Refer to [AT-174, "MAIN POWER SUPPLY AND GROUND CIRCUIT"](#).

OK or NG

- OK >> GO TO 3.
NG >> Repair or replace damaged parts.

3. DETECT MALFUNCTIONING ITEM

Check the following items:

- The A/T assembly harness connector pin terminals for damage or loose connection with harness connector.

OK or NG

- OK >> Replace the control valve with TCM. Refer to [AT-250, "Control Valve With TCM and A/T Fluid Temperature Sensor 2"](#).
- NG >> Repair or replace damaged parts.

4. CHECK DTC

Perform "DTC Confirmation Procedure".

- Refer to [AT-132, "DTC Confirmation Procedure"](#).

OK or NG

- OK >> **INSPECTION END**
NG >> GO TO 2.

DTC P1721 VEHICLE SPEED SENSOR MTR

DTC P1721 VEHICLE SPEED SENSOR MTR

PPF:24814

Description

ECS00AZ7

The vehicle speed sensor-MTR signal is transmitted from combination meter to TCM by CAN communication line. The signal functions as an auxiliary device to the revolution sensor when it is malfunctioning. The TCM will then use the vehicle speed sensor-MTR signal.

CONSULT-II Reference Value

ECS00AZ8

Item name	Condition	Display value (km/h)
VHCL/S SE-MTR	During driving	Approximately matches the speedometer reading.

On Board Diagnosis Logic

ECS00AZ9

- This is not an OBD-II self-diagnostic item.
- Diagnostic trouble code "P1721 VHE SPD SE-MTR" with CONSULT-II is detected when TCM does not receive the proper vehicle speed sensor MTR signal (input by CAN communication) from combination meter.

Possible Cause

ECS00AZA

Harness or connectors
(The sensor circuit is open or shorted.)

DTC Confirmation Procedure

ECS00AZB

CAUTION:

Always drive vehicle at a safe speed.

NOTE:

If "DTC Confirmation Procedure" has been previously performed, always turn ignition switch "OFF" and wait at least 10 seconds before performing the next test.

After the repair, perform the following procedure to confirm the malfunction is eliminated.

④ WITH CONSULT-II

1. Turn ignition switch "ON". (Do not start engine.)
2. Select "DATA MONITOR" mode for "A/T" with CONSULT-II.
3. Start engine and maintain the following conditions for at least 5 consecutive seconds.
ACCELE POS: 1/8 or less
VHCL SPEED SE: 30 km/h (17 MPH) or more
4. If DTC is detected, go to [AT-135, "Diagnostic Procedure"](#).

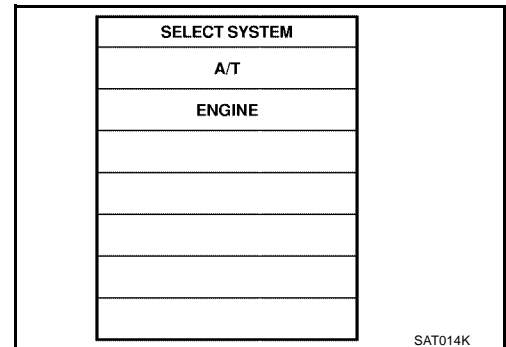

DTC P1721 VEHICLE SPEED SENSOR MTR

ECS00CC9

Diagnostic Procedure

1. CHECK CAN COMMUNICATION LINE

Perform the self-diagnosis. Refer to [AT-87, "SELF-DIAGNOSTIC RESULT MODE"](#).

Is malfunction in the CAN communication indicated in the result?

- YES >> Check CAN communication line. Refer to [AT-97, "DTC U1000 CAN COMMUNICATION LINE"](#).
NO >> GO TO 2.

2. CHECK INPUT SIGNAL

With CONSULT-II

1. Start engine.
2. Select "ECU INPUT SIGNALS" in "DATA MONITOR" mode for "A/T" with CONSULT-II.
3. Drive vehicle and read out the value of "VHCL/S SE-MTR".

Item name	Condition	Display value (Approx.) (km/h)
VHCL/S SE-MTR	During driving	Approximately matches the speedometer reading.

OK or NG

- OK >> GO TO 4.
NG >> GO TO 3.

DATA MONITOR			
MONITOR		NO DTC	
VHCL/S SE-A/T		0km/h	
VHCL/S SE-MTR		0km/h	
ACCELE POSI		0.0/8	
THROTTLE POS		0.0/8	
CLSD THL POS		ON	
W/O THL POS		OFF	
		▽	
		RECORD	
MODE	BACK	LIGHT	COPY

SCIA2148E

3. CHECK COMBINATION METERS

Check combination meters. Refer to [DI-17, "How to Proceed With Trouble Diagnosis"](#).

OK or NG

- OK >> GO TO 4.
NG >> Repair or replace damaged parts.

4. CHECK DTC

Perform "DTC Confirmation Procedure".

- Refer to [AT-134, "DTC Confirmation Procedure"](#).

OK or NG

- OK >> **INSPECTION END**
NG >> GO TO 5.

5. CHECK TCM POWER SUPPLY AND GROUND CIRCUIT

Check TCM power supply and ground circuit. Refer to [AT-174, "MAIN POWER SUPPLY AND GROUND CIRCUIT"](#).

OK or NG

- OK >> GO TO 6.
NG >> Repair or replace damaged parts.

6. DETECT MALFUNCTIONING ITEM

Check the following items:

- The A/T assembly harness connector pin terminals for damage or loose connection with harness connector.

OK or NG

- OK >> Replace the control valve with TCM. Refer to [AT-250, "Control Valve With TCM and A/T Fluid Temperature Sensor 2"](#).
NG >> Repair or replace damaged parts.

DTC P1730 A/T INTERLOCK

DTC P1730 A/T INTERLOCK

PPF:00000

Description

ECS00AZD

- Fail-safe function to detect interlock conditions.

On Board Diagnosis Logic

ECS00AZE

- This is an OBD-II self-diagnostic item.
- Diagnostic trouble code "P1730 A/T INTERLOCK" with CONSULT-II is detected when TCM does not receive the proper voltage signal from the sensor and switch.
- TCM monitors and compares gear position and conditions of each ATF pressure switch when gear is steady.

Possible Cause

ECS00AZF

- Harness or connectors
(The solenoid and switch circuit is open or shorted.)
- Low coast brake solenoid valve
- ATF pressure switch 2

DTC Confirmation Procedure

ECS00AZG

NOTE:

If "DTC Confirmation Procedure" has been previously performed, always turn ignition switch "OFF" and wait at least 10 seconds before performing the next test.

After the repair, perform the following procedure to confirm the malfunction is eliminated.

WITH CONSULT-II

1. Turn ignition switch "ON". (Do not start engine.)
2. Select "DATA MONITOR" mode for "A/T" with CONSULT-II.
3. Start engine.
4. Drive vehicle and maintain the following conditions for at least 2 consecutive seconds.
Selector lever: "D" position
5. If DTC is detected, go to [AT-137, "Diagnostic Procedure"](#).

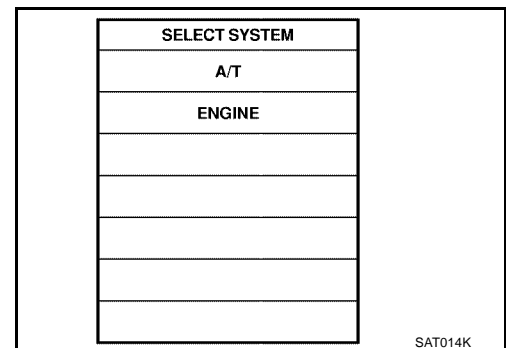

WITH GST

Follow the procedure "With CONSULT-II".

Judgement of A/T Interlock

ECS00AZH

When A/T Interlock is judged to be malfunctioning, the vehicle should be fixed in 2nd gear, and should be set in a condition in which it can travel.

When one of the following fastening patterns is detected, the fail-safe function in correspondence with the individual pattern should be performed.

DTC P1730 A/T INTERLOCK

A/T INTERLOCK COUPLING PATTERN TABLE

●: NG, X: OK

Gear position	ATF pressure switch output					Fail-safe function	Clutch pressure output pattern after fail-safe function						
	SW3 (I/C)	SW6 (HLR/C)	SW5 (D/C)	SW1 (FR/B)	SW2 (LC/B)		I/C	HLR/C	D/C	FR/B	LC/B	L/U	
A/T interlock coupling pattern	3rd	–	X	X	–	●	Held in 2nd gear	OFF	OFF	ON	OFF	OFF	OFF
	4th	–	X	X	–	●	Held in 2nd gear	OFF	OFF	ON	OFF	OFF	OFF
	5th	X	X	–	X	●	Held in 2nd gear	OFF	OFF	ON	OFF	OFF	OFF

Diagnostic Procedure

ECS00CCA

1. SELF-DIAGNOSIS

① With CONSULT-II

1. Drive vehicle.
2. Stop vehicle and turn ignition switch OFF.
3. Turn ignition switch ON.
4. Select "SELF-DIAG RESULTS" mode for "A/T" with CONSULT-II.

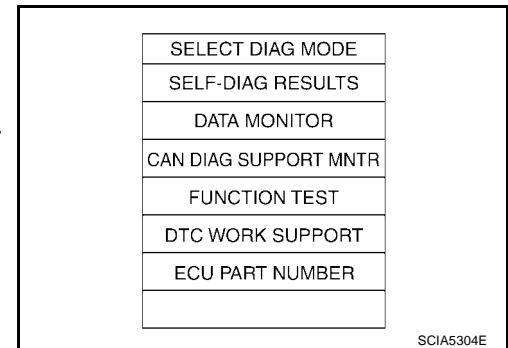

OK or NG

- OK >> GO TO 2.
 NG >> Check low coast brake solenoid valve circuit and function. Refer to [AT-157, "DTC P1772 LOW COAST BRAKE SOLENOID VALVE"](#), [AT-159, "DTC P1774 LOW COAST BRAKE SOLENOID VALVE FUNCTION"](#).

2. CHECK DTC

Perform "DTC Confirmation Procedure".

- Refer to [AT-136, "DTC Confirmation Procedure"](#).

OK or NG

- OK >> **INSPECTION END**
 NG >> GO TO 3.

3. CHECK TCM POWER SUPPLY AND GROUND CIRCUIT

Check TCM power supply and ground circuit. Refer to [AT-174, "MAIN POWER SUPPLY AND GROUND CIRCUIT"](#).

OK or NG

- OK >> GO TO 4.
 NG >> Repair or replace damaged parts.

DTC P1730 A/T INTERLOCK

4. DETECT MALFUNCTIONING ITEM

Check the following items:

- The A/T assembly harness connector pin terminals for damage or loose connection with harness connector.

OK or NG

OK >> Replace the control valve with TCM. Refer to [AT-250, "Control Valve With TCM and A/T Fluid Temperature Sensor 2"](#).

NG >> Repair or replace damaged parts.

DTC P1731 A/T 1ST ENGINE BRAKING

DTC P1731 A/T 1ST ENGINE BRAKING

PF0:0000

Description

ECS00AZJ

Fail-safe function to prevent sudden decrease in speed by engine brake other than at 1 or M1 position.

CONSULT-II Reference Value

ECS00AZK

Item name	Condition	Display value
ON OFF SOL	Low coast brake engaged. Refer to AT-18 , AT-20 .	ON
	Low coast brake disengaged. Refer to AT-18 , AT-20 .	OFF
ATF PRES SW 2	Low coast brake engaged. Refer to AT-18 , AT-20 .	ON
	Low coast brake disengaged. Refer to AT-18 , AT-20 .	OFF

On Board Diagnosis Logic

ECS00AZL

- This is not an OBD-II self-diagnostic item.
- Diagnostic trouble code “P1731 A/T 1ST E/BRAKING” with CONSULT-II is detected under the following conditions.
 - When TCM does not receive the proper voltage signal from the sensor.
 - When TCM monitors each ATF pressure switch and solenoid monitor value, and detects as irregular when engine brake of 1st gear acts other than at 1 position.

Possible Cause

ECS00AZM

- Harness or connectors
(The sensor circuit is open or shorted.)
- Low coast brake solenoid valve
- ATF pressure switch 2

DTC Confirmation Procedure

ECS00AZN

NOTE:

If “DTC Confirmation Procedure” has been previously preformed, always turn ignition switch “OFF” and wait at least 10 seconds before performing the next test.

After the repair, perform the following procedure to confirm the malfunction is eliminated.

WITH CONSULT-II

1. Turn ignition switch “ON”. (Do not start engine.)
2. Select “DATA MONITOR” mode for “A/T” with CONSULT-II.
3. Start engine.
4. Drive vehicle and maintain the following conditions for at least 2 consecutive seconds.
ENGINE SPEED: 1,200 rpm
Selector lever: “1” position
Gear position: 1st gear
5. If DTC is detected, go to [AT-140](#), “Diagnostic Procedure” .

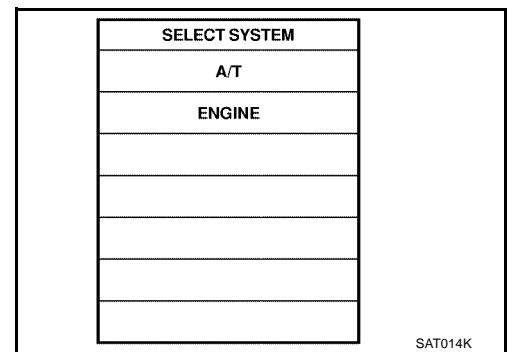

DTC P1731 A/T 1ST ENGINE BRAKING

ECS00AZ0

Diagnostic Procedure

1. CHECK INPUT SIGNALS

With CONSULT-II

1. Start the engine.
2. Select "SELECTION FROM MENU" in "DATA MONITOR" mode for "A/T" with CONSULT-II.
3. Drive vehicle in the "1" or "M" position (1st gear), and confirm the ON/OFF actuation of "ATF PRES SW 2" and "ON OFF SOL".

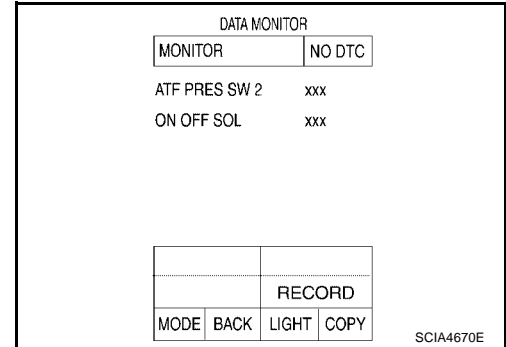

Item name	Condition	Display value
ON OFF SOL	Low coast brake engaged. Refer to AT-18 , AT-20 .	ON
	Low coast brake disengaged. Refer to AT-18 , AT-20 .	OFF
ATF PRES SW 2	Low coast brake engaged. Refer to AT-18 , AT-20 .	ON
	Low coast brake disengaged. Refer to AT-18 , AT-20 .	OFF

OK or NG

- OK >> GO TO 4.
NG >> GO TO 2.

2. CHECK TCM POWER SUPPLY AND GROUND CIRCUIT

Check TCM power supply and ground circuit. Refer to [AT-174](#), "[MAIN POWER SUPPLY AND GROUND CIRCUIT](#)".

OK or NG

- OK >> GO TO 3.
NG >> Repair or replace damaged parts.

3. DETECT MALFUNCTIONING ITEM

Check the following items:

- The A/T assembly harness connector pin terminals for damage or loose connection with harness connector.

OK or NG

- OK >> Replace the control valve with TCM. Refer to [AT-250](#), "[Control Valve With TCM and A/T Fluid Temperature Sensor 2](#)".
NG >> Repair or replace damaged parts.

4. CHECK DTC

Perform "DTC Confirmation Procedure".

- Refer to [AT-139](#), "[DTC Confirmation Procedure](#)".

OK or NG

- OK >> **INSPECTION END**
NG >> GO TO 2.

DTC P1752 INPUT CLUTCH SOLENOID VALVE

DTC P1752 INPUT CLUTCH SOLENOID VALVE

PF3:31940

Description

ECS00AZP

Input clutch solenoid valve is controlled by the TCM in response to signals sent from the PNP switch, vehicle speed sensor and accelerator pedal position sensor (throttle position sensor). Gears will then be shifted to the optimum position.

CONSULT-II Reference Value

ECS00AZQ

Item name	Condition	Display value (Approx.) (A)
I/C SOLENOID	Input clutch disengaged. Refer to AT-18 , AT-20 .	0.6 - 0.8
	Input clutch engaged. Refer to AT-18 , AT-20 .	0 - 0.05

On Board Diagnosis Logic

ECS00AZR

- This is an OBD-II self-diagnostic item.
- Diagnostic trouble code “P1752 I/C SOLENOID/CIRC” with CONSULT-II is detected under the following conditions.
 - When TCM detects an improper voltage drop when it tries to operate the solenoid valve.
 - When TCM detects as irregular by comparing target value with monitor value.

Possible Cause

ECS00AZS

- Harness or connectors
(The solenoid circuit is open or shorted.)
- Input clutch solenoid valve

DTC Confirmation Procedure

ECS00AZT

CAUTION:

Always drive vehicle at a safe speed.

NOTE:

If “DTC Confirmation Procedure” has been previously performed, always turn ignition switch “OFF” and wait at least 10 seconds before performing the next test.

After the repair, perform the following procedure to confirm the malfunction is eliminated.

④ WITH CONSULT-II

1. Turn ignition switch “ON”. (Do not start engine.)
2. Select “DATA MONITOR” mode for “A/T” with CONSULT-II.
3. Start engine.
4. Drive vehicle and maintain the following conditions for at least 5 consecutive seconds.

ACCELE POS: 1.5/8 - 2.0/8

Selector lever: “D” position

Gear position: 3rd ⇒ 4th Gear (I/C ON/OFF)

Driving location: Driving the vehicle uphill (increased engine load) will help maintain the driving conditions required for this test.

5. If DTC is detected go to [AT-142](#), “Diagnostic Procedure” .

④ WITH GST

Follow the procedure “With CONSULT-II”.

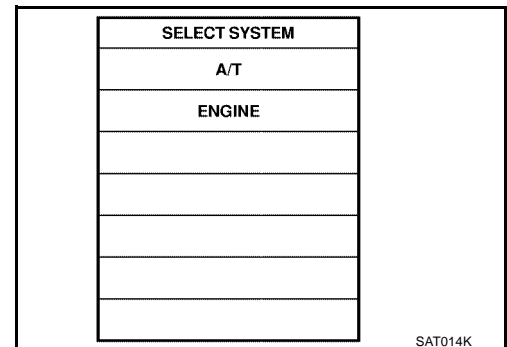

DTC P1752 INPUT CLUTCH SOLENOID VALVE

ECS00CCB

Diagnostic Procedure

1. CHECK INPUT SIGNAL

With CONSULT-II

1. Turn ignition switch ON.
2. Select "MAIN SIGNALS" in "DATA MONITOR" mode for "A/T" with CONSULT-II.
3. Start the engine.
4. Read out the value of "I/C SOLENOID" while driving.

DATA MONITOR			
MONITOR		NO DTC	
TCC SOLENOID		XXXX	
LINE PRES SOL		XXXX	
I/C SOLENOID		XXXX	
FR/B SOLENOID		XXXX	
D/C SOLENOID		XXXX	
HLR/C SOL		XXXX	
		▽	
		RECORD	
MODE	BACK	LIGHT	COPY

SCIA4793E

Item name	Condition	Display value (Approx.)
I/C SOLENOID	Input clutch disengaged. Refer to AT-18 , AT-20 .	0.6 - 0.8 A
	Input clutch engaged. Refer to AT-18 , AT-20 .	0 - 0.05 A

OK or NG

- OK >> GO TO 4.
NG >> GO TO 2.

2. CHECK TCM POWER SUPPLY AND GROUND CIRCUIT

Check TCM power supply and ground circuit. Refer to [AT-174, "MAIN POWER SUPPLY AND GROUND CIRCUIT"](#) .

OK or NG

- OK >> GO TO 3.
NG >> Repair or replace damaged parts.

3. DETECT MALFUNCTIONING ITEM

Check the following items:

- The A/T assembly harness connector pin terminals for damage or loose connection with harness connector.

OK or NG

- OK >> Replace the control valve with TCM. Refer to [AT-250, "Control Valve With TCM and A/T Fluid Temperature Sensor 2"](#) .
NG >> Repair or replace damaged parts.

4. CHECK DTC

Perform "DTC Confirmation Procedure".

- Refer to [AT-141, "DTC Confirmation Procedure"](#) .

OK or NG

- OK >> **INSPECTION END**
NG >> GO TO 2.

DTC P1754 INPUT CLUTCH SOLENOID VALVE FUNCTION

DTC P1754 INPUT CLUTCH SOLENOID VALVE FUNCTION

PF3:31940

Description

ECS00AZV

- Input clutch solenoid valve is controlled by the TCM in response to signals sent from the PNP switch, vehicle speed sensor and accelerator pedal position sensor (throttle position sensor). Gears will then be shifted to the optimum position.
- This is not only caused by electrical malfunction (circuits open or shorted) but also by mechanical malfunction such as control valve sticking, improper solenoid valve operation.

CONSULT-II Reference Value

ECS00AZW

Item name	Condition	Display value (Approx.) (A)
I/C SOLENOID	Input clutch disengaged. Refer to AT-18 , AT-20 .	0.6 - 0.8
	Input clutch engaged. Refer to AT-18 , AT-20 .	0 - 0.05
ATF PRES SW 3	Input clutch engaged. Refer to AT-18 , AT-20 .	ON
	Input clutch disengaged. Refer to AT-18 , AT-20 .	OFF

On Board Diagnosis Logic

ECS00AZX

- This is an OBD-II self-diagnostic item.
- Diagnostic trouble code “P1754 I/C SOLENOID FNCTN” with CONSULT-II is detected under the following conditions.
 - When TCM detects that actual gear ratio is irregular, and relation between gear position and condition of pressure switch 3 is irregular during depressing accelerator pedal. (Other than during shift change)
 - When TCM detects that relation between gear position and condition of ATF pressure switch 3 is irregular during releasing accelerator pedal. (Other than during shift change)

Possible Cause

ECS00AZY

- Harness or connectors
(The solenoid and switch circuits are open or shorted.)
- Input clutch solenoid valve
- ATF pressure switch 3

DTC Confirmation Procedure

ECS00AZZ

CAUTION:

Always drive vehicle at a safe speed.

NOTE:

If “DTC Confirmation Procedure” has been previously performed, always turn ignition switch “OFF” and wait at least 10 seconds before performing the next test.

After the repair, perform the following procedure to confirm the malfunction is eliminated.

WITH CONSULT-II

1. Start engine.
2. Accelerate vehicle to maintain the following conditions.
ACCELE POSI: 1.5/8 - 2.0/8
Selector lever: “D” position
Gear position: 3rd ⇒ 4th Gear (I/C ON/OFF)
Driving location: Driving the vehicle uphill (increased engine load) will help maintain the driving conditions required for this test.
3. Perform step “2” again.
4. Turn ignition switch “OFF”, then perform step “1” to “3” again.
5. Check “SELF-DIAG RESULTS” mode for “A/T” with CONSULT-II. If DTC (P1754) is detected, refer to [AT-144, "Diagnostic Procedure"](#) .
If DTC (P1752) is detected, go to [AT-142, "Diagnostic Procedure"](#) .
If DTC (P1843) is detected, go to [AT-169, "Diagnostic Procedure"](#) .

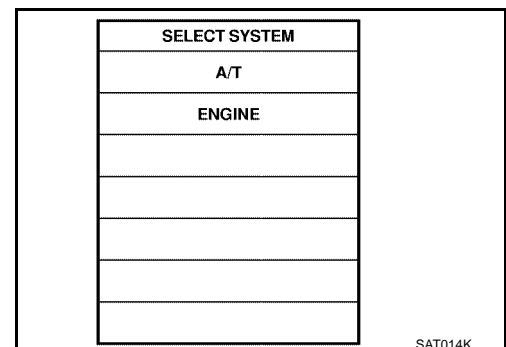

DTC P1754 INPUT CLUTCH SOLENOID VALVE FUNCTION

WITH GST

Follow the procedure "With CONSULT-II".

Diagnostic Procedure

ECS00CCC

1. CHECK INPUT SIGNALS

With CONSULT-II

1. Start engine.
2. Select "SELECTION FROM MENU" in "DATA MONITOR" mode for "A/T" with CONSULT-II.
3. Drive vehicle in "D" position (3rd ⇒ 4th gear), and confirm the ON/OFF actuation of "ATF PRES SW 3" and electrical current value of "I/C SOLENOID".

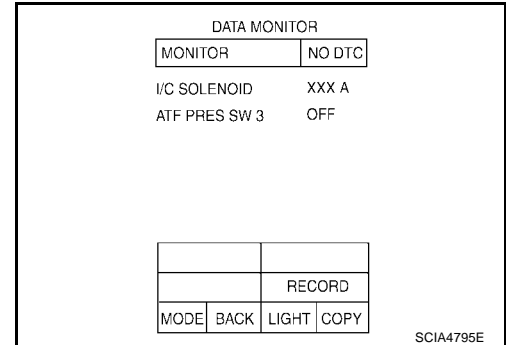

Item name	Condition	Display value (Approx.)
I/C SOLENOID	Input clutch disengaged. Refer to AT-18 , AT-20 .	0.6 - 0.8 A
	Input clutch engaged. Refer to AT-18 , AT-20 .	0 - 0.05 A
ATF PRES SW 3	Input clutch engaged. Refer to AT-18 , AT-20 .	ON
	Input clutch disengaged. Refer to AT-18 , AT-20 .	OFF

OK or NG

- OK >> GO TO 4.
- NG >> GO TO 2.

2. CHECK TCM POWER SUPPLY AND GROUND CIRCUIT

Check TCM power supply and ground circuit. Refer to [AT-174, "MAIN POWER SUPPLY AND GROUND CIRCUIT"](#) .

OK or NG

- OK >> GO TO 3.
- NG >> Repair or replace damaged parts.

3. DETECT MALFUNCTIONING ITEM

Check the following items:

- The A/T assembly harness connector pin terminals for damage or loose connection with harness connector.

OK or NG

- OK >> Replace the control valve with TCM. Refer to [AT-250, "Control Valve With TCM and A/T Fluid Temperature Sensor 2"](#) .
- NG >> Repair or replace damaged parts.

4. CHECK DTC

Perform DTC Confirmation Procedure.

- Refer to [AT-143, "DTC Confirmation Procedure"](#) .

OK or NG

- OK >> **INSPECTION END**
- NG >> GO TO 2.

DTC P1757 FRONT BRAKE SOLENOID VALVE

DTC P1757 FRONT BRAKE SOLENOID VALVE

PF3:31940

Description

ECS00B01

Front brake solenoid valve is controlled by the TCM in response to signals sent from the PNP switch, vehicle speed sensor and accelerator pedal position sensor (throttle position sensor). Gears will then be shifted to the optimum position.

CONSULT-II Reference Value

ECS00B02

Item name	Condition	Display value (Approx.) (A)
FR/B SOLENOID	Front brake engaged. Refer to AT-18 , AT-20 .	0.6 - 0.8
	Front brake disengaged. Refer to AT-18 , AT-20 .	0 - 0.05

On Board Diagnosis Logic

ECS00B03

- This is an OBD-II self-diagnostic item.
- Diagnostic trouble code “P1757 FR/B SOLENOID/CIRC” with CONSULT-II is detected under the following conditions.
 - When TCM detects an improper voltage drop when it tries to operate the solenoid valve.
 - When TCM detects as irregular by comparing target value with monitor value.

Possible Cause

ECS00B04

- Harness or connectors
(The solenoid circuit is open or shorted.)
- Front brake solenoid valve

DTC Confirmation Procedure

ECS00B05

CAUTION:

Always drive vehicle at a safe speed.

NOTE:

If “DTC Confirmation Procedure” has been previously performed, always turn ignition switch “OFF” and wait at least 10 seconds before performing the next test.

After the repair, perform the following procedure to confirm the malfunction is eliminated.

Ⓟ WITH CONSULT-II

1. Turn ignition switch “ON”. (Do not start engine.)
2. Select “DATA MONITOR” mode for “A/T” with CONSULT-II.
3. Start engine.
4. Drive vehicle and maintain the following conditions for at least 5 consecutive seconds.

ACCELE POS: 1.5/8 - 2.0/8

Selector lever: “D” position

Gear position: 3rd ⇒ 4th Gear (FR/B ON/OFF)

Driving location: Driving the vehicle uphill (increased engine load) will help maintain the driving conditions required for this test.

5. If DTC is detected go to [AT-146, "Diagnostic Procedure"](#) .

Ⓢ WITH GST

Follow the procedure “With CONSULT-II”.

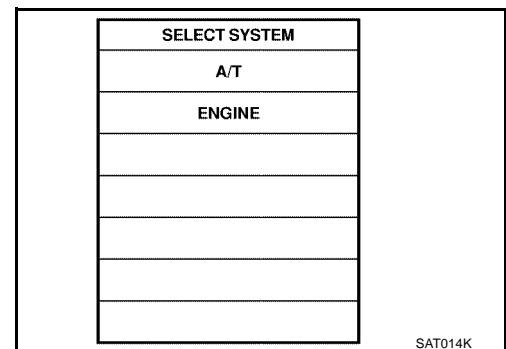

DTC P1757 FRONT BRAKE SOLENOID VALVE

ECS00CCD

Diagnostic Procedure

1. CHECK INPUT SIGNAL

With CONSULT-II

1. Turn ignition switch ON.
2. Select "MAIN SIGNALS" in "DATA MONITOR" mode for "A/T" with CONSULT-II.
3. Start engine.
4. Read out the value of "FR/B SOLENOID" while driving.

DATA MONITOR			
MONITOR		NO DTC	
TCC SOLENOID		XXXX	
LINE PRES SOL		XXXX	
I/C SOLENOID		XXXX	
FR/B SOLENOID		XXXX	
D/C SOLENOID		XXXX	
HLR/C SOL		XXXX	
		▽	
		RECORD	
MODE	BACK	LIGHT	COPY

SCIA4793E

Item name	Condition	Display value (Approx.)
FR/B SOLENOID	Front brake engaged. Refer to AT-18 , AT-20 .	0.6 - 0.8 A
	Front brake disengaged. Refer to AT-18 , AT-20 .	0 - 0.05 A

OK or NG

- OK >> GO TO 4.
NG >> GO TO 2.

2. CHECK TCM POWER SUPPLY AND GROUND CIRCUIT

Check TCM power supply and ground circuit. Refer to [AT-174, "MAIN POWER SUPPLY AND GROUND CIRCUIT"](#) .

OK or NG

- OK >> GO TO 3.
NG >> Repair or replace damaged parts.

3. DETECT MALFUNCTIONING ITEM

Check the following items:

- The A/T assembly harness connector pin terminals for damage or loose connection with harness connector.

OK or NG

- OK >> Replace the control valve with TCM. Refer to [AT-250, "Control Valve With TCM and A/T Fluid Temperature Sensor 2"](#) .
NG >> Repair or replace damaged parts.

4. CHECK DTC

Perform "DTC Confirmation Procedure".

- Refer to [AT-145, "DTC Confirmation Procedure"](#) .

OK or NG

- OK >> **INSPECTION END**
NG >> GO TO 2.

DTC P1759 FRONT BRAKE SOLENOID VALVE FUNCTION

DTC P1759 FRONT BRAKE SOLENOID VALVE FUNCTION

PF3:31940

Description

ECS00B07

- Front brake solenoid valve is controlled by the TCM in response to signals sent from the PNP switch, vehicle speed sensor and accelerator pedal position sensor (throttle position sensor). Gears will then be shifted to the optimum position.
- This is not only caused by electrical malfunction (circuits open or shorted) but also by mechanical malfunction such as control valve sticking, improper solenoid valve operation.

CONSULT-II Reference Value

ECS00B08

Item name	Condition	Display value (Approx.) (A)
FR/B SOLENOID	Front brake engaged. Refer to AT-18 , AT-20 .	0.6 - 0.8
	Front brake disengaged. Refer to AT-18 , AT-20 .	0 - 0.05
ATF PRES SW 1	Front brake engaged. Refer to AT-18 , AT-20 .	ON
	Front brake disengaged. Refer to AT-18 , AT-20 .	OFF

On Board Diagnosis Logic

ECS00B09

- This is an OBD-II self-diagnostic item.
- Diagnostic trouble code "P1759 FR/B SOLENOID FNCT" with CONSULT-II is detected under the following conditions.
 - When TCM detects that actual gear ratio is irregular, and relation between gear position and condition of ATF pressure switch 1 is irregular during depressing accelerator pedal. (Other than during shift change)
 - When TCM detects that relation between gear position and condition of ATF pressure switch 1 is irregular during releasing accelerator pedal. (Other than during shift change)

Possible Cause

ECS00B0A

- Harness or connectors
(The solenoid and switch circuits are open or shorted.)
- Front brake solenoid valve
- ATF pressure switch 1

DTC Confirmation Procedure

ECS00B0B

CAUTION:

Always drive vehicle at a safe speed.

NOTE:

If "DTC Confirmation Procedure" has been previously performed, always turn ignition switch "OFF" and wait at least 10 seconds before performing the next test.

After the repair, perform the following procedure to confirm the malfunction is eliminated.

WITH CONSULT-II

1. Start engine.
2. Accelerate vehicle to maintain the following conditions.
ACCELE POS: 1.5/8 - 2.0/8
Selector lever: "D" position
Gear position: 3rd ⇒ 4th Gear (FR/B ON/OFF)
Driving location: Driving the vehicle uphill (increased engine load) will help maintain the driving conditions required for this test.
3. Perform step "2" again.
4. Turn ignition switch "OFF", then perform step "1" to "3" again.
5. Check "SELF-DIAG RESULTS" mode for "A/T" with CONSULT-II. If DTC (P1759) is detected, refer to [AT-148, "Diagnostic Procedure"](#) .
If DTC (P1757) is detected, go to [AT-146, "Diagnostic Procedure"](#) .
If DTC (P1841) is detected, go to [AT-167, "Diagnostic Procedure"](#) .

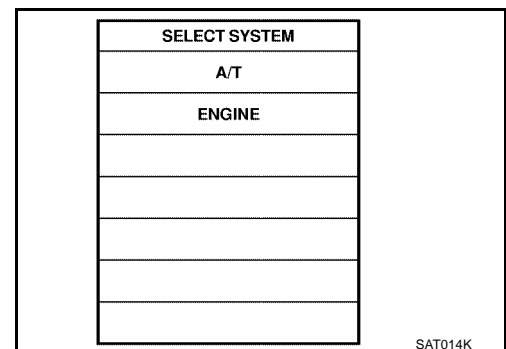

SAT014K

DTC P1759 FRONT BRAKE SOLENOID VALVE FUNCTION

WITH GST

Follow the procedure "With CONSULT-II".

Diagnostic Procedure

ECS00B0C

1. CHECK INPUT SIGNALS

With CONSULT-II

1. Start engine.
2. Select "SELECTION FROM MENU" in "DATA MONITOR" mode for "A/T" with CONSULT-II.
3. Drive vehicle in the "D" position (3rd ⇒ 4th gear), and confirm the ON/OFF actuation of the "ATF PRES SW 1" and electrical current value of "FR/B SOLENOID".

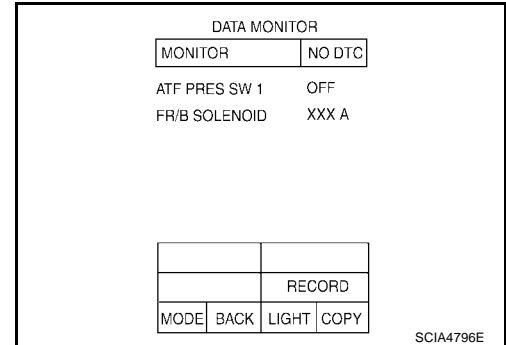

Item name	Condition	Display value (Approx.)
FR/B SOLENOID	Front brake engaged. Refer to AT-18 , AT-20 .	0.6 - 0.8 A
	Front brake disengaged. Refer to AT-18 , AT-20 .	0 - 0.05 A
ATF PRES SW 1	Front brake engaged. Refer to AT-18 , AT-20 .	ON
	Front brake disengaged. Refer to AT-18 , AT-20 .	OFF

OK or NG

- OK >> GO TO 4.
NG >> GO TO 2.

2. CHECK TCM POWER SUPPLY AND GROUND CIRCUIT

Check TCM power supply and ground circuit. Refer to [AT-174, "MAIN POWER SUPPLY AND GROUND CIRCUIT"](#) .

OK or NG

- OK >> GO TO 3.
NG >> Repair or replace damaged parts.

3. DETECT MALFUNCTIONING ITEM

Check the following items:

- The A/T assembly harness connector pin terminals for damage or loose connection with harness connector.

OK or NG

- OK >> Replace the control valve with TCM. Refer to [AT-250, "Control Valve With TCM and A/T Fluid Temperature Sensor 2"](#) .
NG >> Repair or replace damaged parts.

4. CHECK DTC

Perform "DTC Confirmation Procedure".

- Refer to [AT-147, "DTC Confirmation Procedure"](#) .

OK or NG

- OK >> **INSPECTION END**
NG >> GO TO 2.

DTC P1762 DIRECT CLUTCH SOLENOID VALVE

DTC P1762 DIRECT CLUTCH SOLENOID VALVE

PF3:31940

Description

ECS00B0D

Direct clutch solenoid valve is controlled by the TCM in response to signals sent from the PNP switch, vehicle speed sensor and accelerator pedal position sensor (throttle position sensor). Gears will then be shifted to the optimum position.

CONSULT-II Reference Value

ECS00B0E

Item name	Condition	Display value (Approx.) (A)
D/C SOLENOID	Direct clutch disengaged. Refer to AT-20 , AT-18 .	0.6 - 0.8
	Direct clutch engaged. Refer to AT-20 , AT-18 .	0 - 0.05

On Board Diagnosis Logic

ECS00B0F

- This is an OBD-II self-diagnostic item.
- Diagnostic trouble code "P1762 D/C SOLENOID/CIRC" with CONSULT-II is detected under the following conditions.
 - When TCM detects an improper voltage drop when it tries to operate the solenoid valve.
 - When TCM detects as irregular by comparing target value with monitor value.

Possible Cause

ECS00B0G

- Harness or connectors
(The solenoid circuit is open or shorted.)
- Direct clutch solenoid valve

DTC Confirmation Procedure

ECS00B0H

NOTE:

If "DTC Confirmation Procedure" has been previously performed, always turn ignition switch "OFF" and wait at least 10 seconds before performing the next test.

After the repair, perform the following procedure to confirm the malfunction is eliminated.

WITH CONSULT-II

1. Turn ignition switch "ON". (Do not start engine.)
2. Select "DATA MONITOR" mode for "A/T" with CONSULT-II.
3. Start engine.
4. Drive vehicle and maintain the following conditions for at least 5 consecutive seconds.
ACCELE POS: 1.5/8 - 2.0/8
Selector lever: "D" position
Gear position: 1st ⇒ 2nd Gear (D/C ON/OFF)
Driving location: Driving the vehicle uphill (increased engine load) will help maintain the driving conditions required for this test.
5. If DTC is detected, go to [AT-150, "Diagnostic Procedure"](#) .

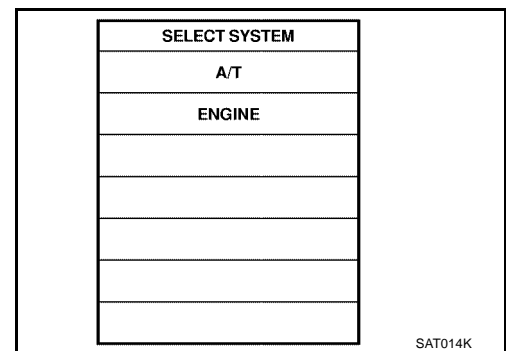

WITH GST

Follow the procedure "With CONSULT-II".

DTC P1762 DIRECT CLUTCH SOLENOID VALVE

ECS00CCE

Diagnostic Procedure

1. CHECK INPUT SIGNAL

With CONSULT-II

1. Turn ignition switch ON.
2. Select "MAIN SIGNALS" in "DATA MONITOR" mode for "A/T" with CONSULT-II.
3. Start the engine.
4. Read out the value of "D/C SOLENOID" while driving.

DATA MONITOR			
MONITOR		NO DTC	
TCC SOLENOID		XXXX	
LINE PRES SOL		XXXX	
I/C SOLENOID		XXXX	
FR/B SOLENOID		XXXX	
D/C SOLENOID		XXXX	
HLR/C SOL		XXXX	
		▽	
RECORD			
MODE	BACK	LIGHT	COPY

SCIA4793E

Item name	Condition	Display value (Approx.)
D/C SOLENOID	Direct clutch disengaged. Refer to AT-18 , AT-20 .	0.6 - 0.8 A
	Direct clutch engaged. Refer to AT-18 , AT-20 .	0 - 0.05 A

OK or NG

- OK >> GO TO 4.
NG >> GO TO 2.

2. CHECK TCM POWER SUPPLY AND GROUND CIRCUIT

Check TCM power supply and ground circuit. Refer to [AT-174, "MAIN POWER SUPPLY AND GROUND CIRCUIT"](#) .

OK or NG

- OK >> GO TO 3.
NG >> Repair or replace damaged parts.

3. DETECT MALFUNCTIONING ITEM

Check the following items:

- The A/T assembly harness connector pin terminals for damage or loose connection with harness connector.

OK or NG

- OK >> Replace the control valve with TCM. Refer to [AT-250, "Control Valve With TCM and A/T Fluid Temperature Sensor 2"](#) .
NG >> Repair or replace damaged parts.

4. CHECK DTC

Perform "DTC Confirmation Procedure".

- Refer to [AT-149, "DTC Confirmation Procedure"](#) .

OK or NG

- OK >> **INSPECTION END**
NG >> GO TO 2.

DTC P1764 DIRECT CLUTCH SOLENOID VALVE FUNCTION

DTC P1764 DIRECT CLUTCH SOLENOID VALVE FUNCTION

PF3:31940

Description

ECS00B0J

- Direct clutch solenoid valve is controlled by the TCM in response to signals sent from the PNP switch, vehicle speed sensor and accelerator pedal position sensor (throttle position sensor). Gears will then be shifted to the optimum position.
- This is not only caused by electrical malfunction (circuits open or shorted) but also by mechanical malfunction such as control valve sticking, improper solenoid valve operation.

CONSULT-II Reference Value

ECS00B0K

Item name	Condition	Display value (Approx) (A)
D/C SOLENOID	Direct clutch disengaged. Refer to AT-18 , AT-20 .	0.6 - 0.8
	Direct clutch engaged. Refer to AT-20 , AT-18 .	0 - 0.05
ATF PRES SW 5	Direct clutch engaged. Refer to AT-18 , AT-20 .	ON
	Direct clutch disengaged. Refer to AT-20 , AT-18 .	OFF

On Board Diagnosis Logic

ECS00B0L

- This is an OBD-II self-diagnostic item.
- Diagnostic trouble code "P1764 D/C SOLENOID FNCTN" with CONSULT-II is detected under the following conditions.
 - When TCM detects that actual gear ratio is irregular, and relation between gear position and condition of ATF pressure switch 5 is irregular during depressing accelerator pedal. (Other than during shift change)
 - When TCM detects that relation between gear position and condition of ATF pressure switch 5 is irregular during releasing accelerator pedal. (Other than during shift change)

Possible Cause

ECS00B0M

- Harness or connectors
(The solenoid and switch circuits are open or shorted.)
- Direct clutch solenoid valve
- ATF pressure switch 5

DTC Confirmation Procedure

ECS00B0N

NOTE:

If "DTC Confirmation Procedure" has been previously performed, always turn ignition switch "OFF" and wait at least 10 seconds before performing the next test.

After the repair, perform the following procedure to confirm the malfunction is eliminated.

WITH CONSULT-II

1. Start engine.
2. Accelerate vehicle to maintain the following conditions.
ACCELE POS: 1.5/8 - 2.0/8
Selector lever: "D" position
Gear position: 1st ⇒ 2nd Gear (D/C ON/OFF)
Driving location: Driving the vehicle uphill (increased engine load) will help maintain the driving conditions required for this test.
3. Perform step "2" again.
4. Turn ignition switch "OFF", then perform step "1" to "3" again.
5. Check "SELF-DIAG RESULTS" mode for "A/T" with CONSULT-II. If DTC (P1764) is detected, refer to [AT-152, "Diagnostic Procedure"](#) .
If DTC (P1762) is detected, go to [AT-150, "Diagnostic Procedure"](#) .
If DTC (P1845) is detected, go to [AT-171, "Diagnostic Procedure"](#) .

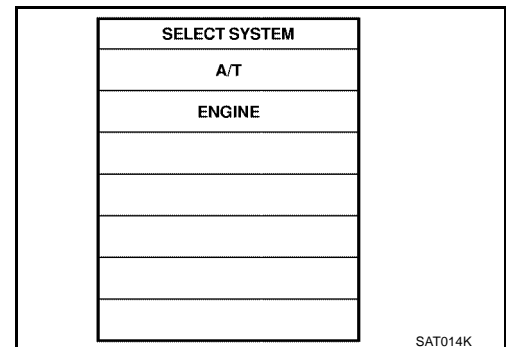

WITH GST

Follow the procedure "With CONSULT-II".

DTC P1764 DIRECT CLUTCH SOLENOID VALVE FUNCTION

ECS00B00

Diagnostic Procedure

1. CHECK INPUT SIGNALS

With CONSULT-II

1. Start engine.
2. Select "SELECTION FROM MENU" in "DATA MONITOR" mode for "A/T" with CONSULT-II.
3. Drive vehicle in the "D" position (1st ⇒ 2nd gear), and confirm the display actuation of the "ATF PRES SW 5" and electrical current value of "D/C SOLENOID".

DATA MONITOR			
MONITOR		NO DTC	
D/C SOLENOID		XXXX	
ATF PRES SW 5		OFF	
RECORD			
MODE	BACK	LIGHT	COPY

SCIA4797E

Item name	Condition	Display value (Approx.)
D/C SOLENOID	Direct clutch disengaged. Refer to AT-18 , AT-20 .	0.6 - 0.8 A
	Direct clutch engaged. Refer to AT-18 , AT-20 .	0 - 0.05 A
ATF PRES SW 5	Direct clutch engaged. Refer to AT-18 , AT-20 .	ON
	Direct clutch disengaged. Refer to AT-18 , AT-20 .	OFF

OK or NG

- OK >> GO TO 4.
NG >> GO TO 2.

2. CHECK TCM POWER SUPPLY AND GROUND CIRCUIT

Check TCM power supply and ground circuit. Refer to [AT-174](#), "[MAIN POWER SUPPLY AND GROUND CIRCUIT](#)".

OK or NG

- OK >> GO TO 3.
NG >> Repair or replace damaged parts.

3. DETECT MALFUNCTIONING ITEM

Check the following items:

- The A/T assembly harness connector pin terminals for damage or loose connection with harness connector.

OK or NG

- OK >> Replace the control valve with TCM. Refer to [AT-250](#), "[Control Valve With TCM and A/T Fluid Temperature Sensor 2](#)".
NG >> Repair or replace damaged parts.

4. CHECK DTC

Perform "DTC Confirmation Procedure".

- Refer to [AT-151](#), "[DTC Confirmation Procedure](#)".

OK or NG

- OK >> **INSPECTION END**
NG >> GO TO 2.

DTC P1767 HIGH AND LOW REVERSE CLUTCH SOLENOID VALVE

DTC P1767 HIGH AND LOW REVERSE CLUTCH SOLENOID VALVE

PF3:31940

Description

ECS00B0P

High and low reverse clutch solenoid valve is controlled by the TCM in response to signals sent from the PNP switch, vehicle speed sensor and accelerator pedal position sensor (throttle position sensor). Gears will then be shifted to the optimum position.

CONSULT-II Reference Value

ECS00B0Q

Item name	Condition	Display value (Approx.) (A)
HLR/C SOL	High and low reverse clutch disengaged. Refer to AT-20 , AT-18 .	0.6 - 0.8
	High and low reverse clutch engaged. Refer to AT-18 , AT-20 .	0 - 0.05

On Board Diagnosis Logic

ECS00B0R

- This is an OBD-II self-diagnostic item.
- Diagnostic trouble code "P1767 HLR/C SOL/CIRC" with CONSULT-II is detected under the following conditions.
 - When TCM detects an improper voltage drop when it tries to operate the solenoid valve.
 - When TCM detects as irregular by comparing target value with monitor value.

Possible Cause

ECS00B0S

- Harness or connectors
(The solenoid circuit is open or shorted.)
- High and low reverse clutch solenoid valve

DTC Confirmation Procedure

ECS00B0T

CAUTION:

Always drive vehicle at a safe speed.

NOTE:

If "DTC Confirmation Procedure" has been previously performed, always turn ignition switch "OFF" and wait at least 10 seconds before performing the next test.

After the repair, perform the following procedure to confirm the malfunction is eliminated.

Ⓟ WITH CONSULT-II

1. Turn ignition switch "ON". (Do not start engine.)
2. Select "DATA MONITOR" mode for "A/T" with CONSULT-II.
3. Start engine.
4. Drive vehicle and maintain the following conditions for at least 5 consecutive seconds.

ACCELE POS: 1.5/8 - 2.0/8

Selector lever: "D" position

Gear position: 2nd ⇒ 3rd Gear (HLR/C ON/OFF)

Driving location: Driving the vehicle uphill (increased engine load) will help maintain the driving conditions required for this test.

5. If DTC is detected, go to [AT-154, "Diagnostic Procedure"](#) .

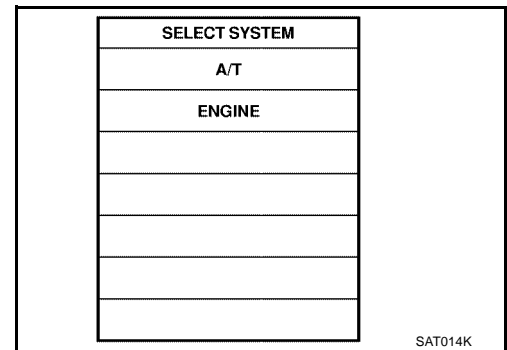

Ⓢ WITH GST

Follow the procedure "With CONSULT-II".

DTC P1767 HIGH AND LOW REVERSE CLUTCH SOLENOID VALVE

ECS00CCF

Diagnostic Procedure

1. CHECK INPUT SIGNAL

With CONSULT-II

1. Turn ignition switch ON.
2. Select "MAIN SIGNALS" in "DATA MONITOR" mode for "A/T" with CONSULT-II.
3. Start the engine.
4. Read out the value of "HLR/C SOLENOID" while driving.

DATA MONITOR			
MONITOR		NO DTC	
TCC SOLENOID		XXXX	
LINE PRES SOL		XXXX	
I/C SOLENOID		XXXX	
FR/B SOLENOID		XXXX	
D/C SOLENOID		XXXX	
HLR/C SOL		XXXX	
		▽	
RECORD			
MODE	BACK	LIGHT	COPY

SCIA4793E

Item name	Condition	Display value (Approx.)
HLR/C SOL	High and low reverse clutch disengaged. Refer to AT-18 , AT-20 .	0.6 - 0.8 A
	High and low reverse clutch engaged. Refer to AT-18 , AT-20 .	0 - 0.05 A

OK or NG

- OK >> GO TO 4.
NG >> GO TO 2.

2. CHECK TCM POWER SUPPLY AND GROUND CIRCUIT

Check TCM power supply and ground circuit. Refer to [AT-174](#), "[MAIN POWER SUPPLY AND GROUND CIRCUIT](#)".

OK or NG

- OK >> GO TO 3.
NG >> Repair or replace damaged parts.

3. DETECT MALFUNCTIONING ITEM

Check the following items:

- The A/T assembly harness connector pin terminals for damage or loose connection with harness connector.

OK or NG

- OK >> Replace the control valve with TCM. Refer to [AT-250](#), "[Control Valve With TCM and A/T Fluid Temperature Sensor 2](#)".
NG >> Repair or replace damaged parts.

4. CHECK DTC

Perform "DTC Confirmation Procedure".

- Refer to [AT-153](#), "[DTC Confirmation Procedure](#)".

OK or NG

- OK >> **INSPECTION END**
NG >> GO TO 2.

DTC P1769 HIGH AND LOW REVERSE CLUTCH SOLENOID VALVE FUNCTION

DTC P1769 HIGH AND LOW REVERSE CLUTCH SOLENOID VALVE FUNCTION

PFP:31940

Description

ECS00B0V

- High and low reverse clutch solenoid valve is controlled by the TCM in response to signals sent from the PNP switch, vehicle speed sensor and accelerator pedal position sensor (throttle position sensor). Gears will then be shifted to the optimum position.
- This is not only caused by electrical malfunction (circuits open or shorted) but also by mechanical malfunction such as control valve sticking, improper solenoid valve operation.

CONSULT-II Reference Value

ECS00B0W

Item name	Condition	Display value (Approx.) (A)
HLR/C SOL	High and low reverse clutch disengaged. Refer to AT-20 , AT-18 .	0.6 - 0.8
	High and low reverse clutch engaged. Refer to AT-20 , AT-18 .	0 - 0.05
ATF PRES SW 6	High and low reverse clutch engaged. Refer to AT-20 , AT-18 .	ON
	High and low reverse clutch disengaged. Refer to AT-20 , AT-18 .	OFF

On Board Diagnosis Logic

ECS00B0X

- This is an OBD-II self-diagnostic item.
- Diagnostic trouble code “P1769 HLR/C SOL FNCTN” with CONSULT-II is detected under the following conditions.
 - When TCM detects that actual gear ratio is irregular, and relation between gear position and condition of ATF pressure switch 6 is irregular during depressing accelerator pedal. (Other than during shift change)
 - When TCM detects that relation between gear position and condition of ATF pressure switch 6 is irregular during releasing accelerator pedal. (Other than during shift change)

Possible Cause

ECS00B0Y

- Harness or connectors
(The solenoid and switch circuits are open or shorted.)
- High and low reverse clutch solenoid valve
- ATF pressure switch 6

DTC Confirmation Procedure

ECS00B0Z

CAUTION:

Always drive vehicle at a safe speed.

NOTE:

If “DTC Confirmation Procedure” has been previously performed, always turn ignition switch “OFF” and wait at least 10 seconds before performing the next test.

After the repair, perform the following procedure to confirm the malfunction is eliminated.

WITH CONSULT-II

1. Start engine.
2. Accelerate vehicle to maintain the following conditions.
ACCELE POS: 1.5/8 - 2.0/8
Selector lever: “D” position
Gear position: 2nd ⇒ 3rd Gear (HLR/C ON/OFF)
Driving location: Driving the vehicle uphill (increased engine load) will help maintain the driving conditions required for this test.
3. Perform step “2” again.
4. Turn ignition switch “OFF”, then perform step “1” to “3” again.
5. Check “SELF-DIAG RESULTS” mode for “A/T” with CONSULT-II. If DTC (P1769) is detected, refer to [AT-156, "Diagnostic Procedure"](#) .
If DTC (P1767) is detected, go to [AT-154, "Diagnostic Procedure"](#) .
If DTC (P1846) is detected, go to [AT-173, "Diagnostic Procedure"](#) .

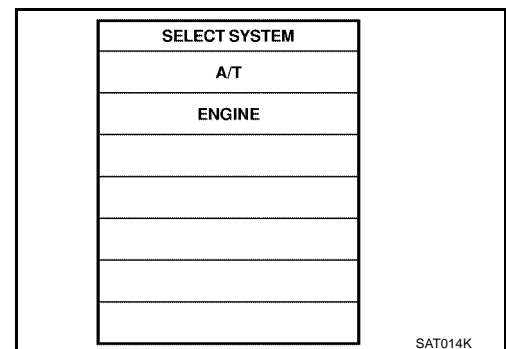

DTC P1769 HIGH AND LOW REVERSE CLUTCH SOLENOID VALVE FUNCTION

WITH GST

Follow the procedure "With CONSULT-II".

Diagnostic Procedure

ECS00B10

1. CHECK INPUT SIGNALS

With CONSULT-II

1. Start the engine.
2. Select "SELECTION FROM MENU" in "DATA MONITOR" mode for "A/T" with CONSULT-II.
3. Drive vehicle in the "D" position (2nd ⇒ 3rd gear), and confirm the ON/OFF actuation of the "ATF PRES SW 6" and electrical current value of "HLR/C SOL".

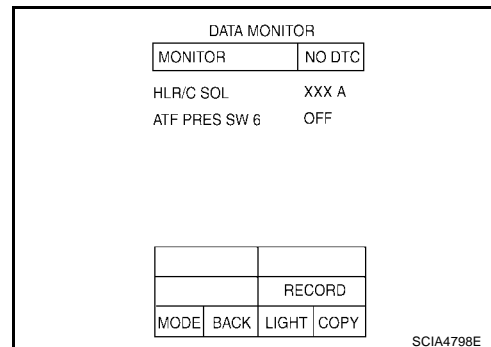

Item name	Condition	Display value (Approx.)
HLR/C SOL	High and low reverse clutch disengaged. Refer to AT-18 , AT-20 .	0.6 - 0.8 A
	High and low reverse clutch engaged. Refer to AT-18 , AT-20 .	0 - 0.05 A
ATF PRES SW 6	High and low reverse clutch engaged. Refer to AT-18 , AT-20 .	ON
	High and low reverse clutch disengaged. Refer to AT-18 , AT-20 .	OFF

OK or NG

- OK >> GO TO 4.
NG >> GO TO 2.

2. CHECK TCM POWER SUPPLY AND GROUND CIRCUIT

Check TCM power supply and ground circuit. Refer to [AT-174, "MAIN POWER SUPPLY AND GROUND CIRCUIT"](#) .

OK or NG

- OK >> GO TO 3.
NG >> Repair or replace damaged parts.

3. DETECT MALFUNCTIONING ITEM

Check the following items:

- The A/T assembly harness connector pin terminals for damage or loose connection with harness connector.

OK or NG

- OK >> Replace the control valve with TCM. Refer to [AT-250, "Control Valve With TCM and A/T Fluid Temperature Sensor 2"](#) .
NG >> Repair or replace damaged parts.

4. CHECK DTC

Perform "DTC Confirmation Procedure".

- Refer to [AT-155, "DTC Confirmation Procedure"](#) .

OK or NG

- OK >> **INSPECTION END**
NG >> GO TO 2.

DTC P1772 LOW COAST BRAKE SOLENOID VALVE

DTC P1772 LOW COAST BRAKE SOLENOID VALVE

PFP:31940

Description

ECS00B11

Low coast brake solenoid valve is turned "ON" or "OFF" by the TCM in response to signals sent from the PNP switch, vehicle speed sensor and accelerator pedal position sensor (throttle position sensor). Gears will then be shifted to the optimum position.

CONSULT-II Reference Value

ECS00B12

Item name	Condition	Display value
ON OFF SOL	Low coast brake engaged. Refer to AT-20 , AT-18 .	ON
	Low coast brake disengaged. Refer to AT-20 , AT-18 .	OFF

On Board Diagnosis Logic

ECS00B13

- This is an OBD-II self-diagnostic item.
- Diagnostic trouble code "P1772 LC/B SOLENOID/CIRC" with CONSULT-II is detected when TCM detects an improper voltage drop when it tries to operate the solenoid valve.

Possible Cause

ECS00B14

- Harness or connectors
(The solenoid circuit is open or shorted.)
- Low coast brake solenoid valve

DTC Confirmation Procedure

ECS00B15

NOTE:

If "DTC Confirmation Procedure" has been previously performed, always turn ignition switch "OFF" and wait at least 10 seconds before performing the next test.

After the repair, perform the following procedure to confirm the malfunction is eliminated.

WITH CONSULT-II

1. Turn ignition switch "ON". (Do not start engine.)
2. Select "DATA MONITOR" mode for "ENGINE" with CONSULT-II.
3. Start engine.
4. Drive vehicle and maintain the following conditions for at least 5 consecutive seconds.
Selector lever: "1" or "2"
Gear position: "1st" or "2nd" gear (LC/B ON/OFF)
5. If DTC is detected, go to [AT-158, "Diagnostic Procedure"](#) .

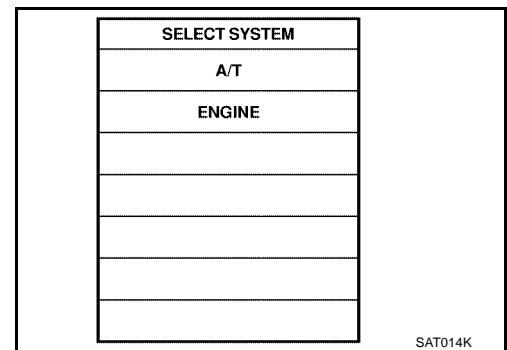

WITH GST

Follow the procedure "With CONSULT-II".

DTC P1772 LOW COAST BRAKE SOLENOID VALVE

ECS00CCG

Diagnostic Procedure

1. CHECK INPUT SIGNAL

With CONSULT-II

1. Turn ignition switch ON.
2. Select "SELECTION FROM MENU" in "DATA MONITOR" mode for "A/T" with CONSULT-II.
3. Start the engine.
4. Read out the value of "ON OFF SOL" while driving.

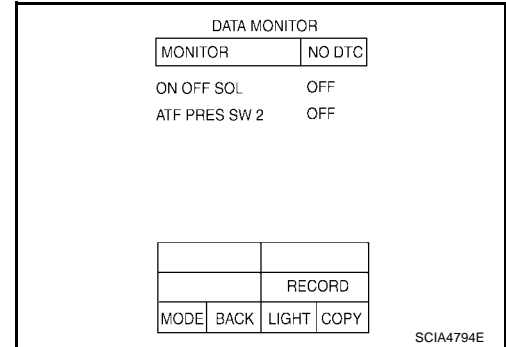

Item name	Condition	Display value
ON OFF SOL	Low coast brake engaged. Refer to AT-18 , AT-20 .	ON
	Low coast brake disengaged. Refer to AT-18 , AT-20 .	OFF

OK or NG

- OK >> GO TO 4.
NG >> GO TO 2.

2. CHECK TCM POWER SUPPLY AND GROUND CIRCUIT

Check TCM power supply and ground circuit. Refer to [AT-174](#), "[MAIN POWER SUPPLY AND GROUND CIRCUIT](#)".

OK or NG

- OK >> GO TO 3.
NG >> Repair or replace damaged parts.

3. DETECT MALFUNCTIONING ITEM

Check the following items:

- The A/T assembly harness connector pin terminals for damage or loose connection with harness connector.

OK or NG

- OK >> Replace the control valve with TCM. Refer to [AT-250](#), "[Control Valve With TCM and A/T Fluid Temperature Sensor 2](#)".
NG >> Repair or replace damaged parts.

4. CHECK DTC

Perform "DTC Confirmation Procedure".

- Refer to [AT-157](#), "[DTC Confirmation Procedure](#)".

OK or NG

- OK >> **INSPECTION END**
NG >> GO TO 2.

DTC P1774 LOW COAST BRAKE SOLENOID VALVE FUNCTION

DTC P1774 LOW COAST BRAKE SOLENOID VALVE FUNCTION

PF3:31940

Description

ECS00B17

- Low coast brake solenoid valve is turned “ON” or “OFF” by the TCM in response to signals sent from the PNP switch, vehicle speed sensor and accelerator pedal position sensor (throttle position sensor). Gears will then be shifted to the optimum position.
- This is not only caused by electrical malfunction (circuits open or shorted) but also by mechanical malfunction such as control valve sticking, improper solenoid valve operation.

CONSULT-II Reference Value

ECS00B18

Item name	Condition	Display value
ON OFF SOL	Low coast brake engaged. Refer to AT-18 , AT-20 .	ON
	Low coast brake disengaged. Refer to AT-20 , AT-18 .	OFF
ATF PRES SW 2	Low coast brake engaged. Refer to AT-20 , AT-18 .	ON
	Low coast brake disengaged. Refer to AT-20 , AT-18 .	OFF

On Board Diagnosis Logic

ECS00B19

- This is an OBD-II self-diagnostic item.
- Diagnostic trouble code “P1774 LC/B SOLENOID FNCT” with CONSULT-II is detected under the following conditions.
 - When TCM detects that actual gear ratio is irregular, and relation between gear position and condition of ATF pressure switch 2 is irregular during depressing accelerator pedal. (Other than during shift change)
 - When TCM detects that relation between gear position and condition of ATF pressure switch 2 is irregular during releasing accelerator pedal. (Other than during shift change)

Possible Cause

ECS00B1A

- Harness or connectors
(The solenoid and switch circuits are open or shorted.)
- Low coast brake solenoid valve
- ATF pressure switch 2

DTC Confirmation Procedure

ECS00B1B

CAUTION:

Always drive vehicle at a safe speed.

NOTE:

If “DTC Confirmation Procedure” has been previously performed, always turn ignition switch “OFF” and wait at least 10 seconds before performing the next test.

After the repair, perform the following procedure to confirm the malfunction is eliminated.

WITH CONSULT-II

1. Start engine.
2. Accelerate vehicle to maintain the following conditions.
Selector lever: “1” or “2” position
Gear position: “1st” or “2nd” gear (LC/B ON/OFF)
3. Perform step “2” again.
4. Turn ignition switch “OFF”, then perform step “1” to “3” again.
5. Check “SELF-DIAG RESULTS” mode for “A/T” with CONSULT-II. If DTC (P1774) is detected, refer to [AT-160](#), “[Diagnostic Procedure](#)” .
If DTC (P1772) is detected, go to [AT-158](#), “[Diagnostic Procedure](#)” .

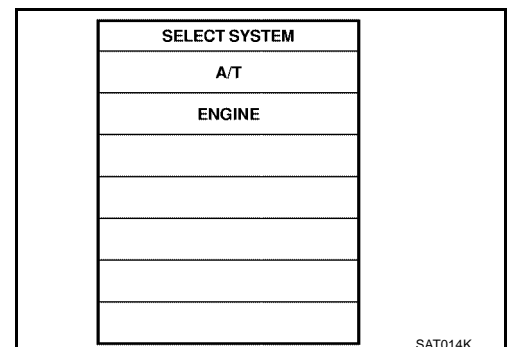

WITH GST

Follow the procedure “With CONSULT-II”.

DTC P1774 LOW COAST BRAKE SOLENOID VALVE FUNCTION

ECS00CCH

Diagnostic Procedure

1. CHECK INPUT SIGNALS

With CONSULT-II

1. Start the engine.
2. Select "SELECTION FROM MENU" in "DATA MONITOR" mode for "A/T" with CONSULT-II.
3. Drive vehicle in the 1 or 2 position ("1 " or "2 " gear) or manual mode ("M1-1st" or "M2-2nd" gear), and confirm the ON/OFF actuation of the "ATF PRES SW 2" and "ON OFF SOL".

DATA MONITOR			
MONITOR	NO DTC		
ON OFF SOL	OFF		
ATF PRES SW 2	OFF		
		RECORD	
MODE	BACK	LIGHT	COPY

SCIA4794E

Item name	Condition	Display value
ON OFF SOL	Low coast brake engaged. Refer to AT-18 , AT-20 .	ON
	Low coast brake disengaged. Refer to AT-18 , AT-20 .	OFF
ATF PRES SW 2	Low coast brake engaged. Refer to AT-18 , AT-20 .	ON
	Low coast brake disengaged. Refer to AT-18 , AT-20 .	OFF

OK or NG

- OK >> GO TO 4.
NG >> GO TO 2.

2. CHECK TCM POWER SUPPLY AND GROUND CIRCUIT

Check TCM power supply and ground circuit. Refer to [AT-174, "MAIN POWER SUPPLY AND GROUND CIRCUIT"](#) .

OK or NG

- OK >> GO TO 3.
NG >> Repair or replace damaged parts.

3. DETECT MALFUNCTIONING ITEM

Check the following items:

- The A/T assembly harness connector pin terminals for damage or loose connection with harness connector.

OK or NG

- OK >> Replace the control valve with TCM. Refer to [AT-250, "Control Valve With TCM and A/T Fluid Temperature Sensor 2"](#) .
NG >> Repair or replace damaged parts.

4. CHECK DTC

Perform "DTC Confirmation Procedure".

- Refer to [AT-159, "DTC Confirmation Procedure"](#) .

OK or NG

- OK >> **INSPECTION END**
NG >> GO TO 2.

DTC P1815 MANUAL MODE SWITCH

DTC P1815 MANUAL MODE SWITCH

PF3:34901

Description

ECS00B1D

When an impossible pattern of switch signals is detected, this is judged to be an irregularity.

CONSULT-II Reference Value in Data Monitor Mode

ECS00B1E

Monitor Item	Condition	Reference Value
MANU MODE SW [ON - OFF]	Manual shift gate position (neutral)	ON
	Other than the above	OFF
NON M-MODE SW [ON - OFF]	Manual shift gate position	OFF
	Other than the above	ON
UP SW LEVER [ON - OFF]	Select lever: + side	ON
	Other than the above	OFF
DOWN SW LEVER [ON - OFF]	Select lever: - side	ON
	Other than the above	OFF

On Board Diagnosis Logic

ECS00B1F

- This is not an OBD-II self-diagnostic item.
- Diagnostic trouble code “MANU MODE SW/CIR” with CONSULT-II is detected when TCM monitors Manual mode, Non manual mode, Up or Down switch signal, and detects as irregular when impossible input pattern occurs 1 second or more.

Possible Cause

ECS00B1G

- Harness or connectors (These switches circuit is open or shorted.)
- Mode select switch (Into control device)
- Position select switch (Into control device)

DTC Confirmation Procedure

ECS00B1H

NOTE:

If “DTC Confirmation Procedure” has been previously performed, always turn ignition switch “OFF” and wait at least 10 seconds before performing the next test.

After the repair, perform the following procedure to confirm the malfunction is eliminated.

WITH CONSULT-II

1. Turn ignition switch “ON”. (Do not start engine.)
2. Select “DATA MONITOR” mode for “A/T” with CONSULT-II.
3. Move selector lever to “M” position.
4. Start engine and drive vehicle for at least 2 consecutive seconds.
5. If DTC is detected, go to [AT-163, "Diagnostic Procedure"](#) .

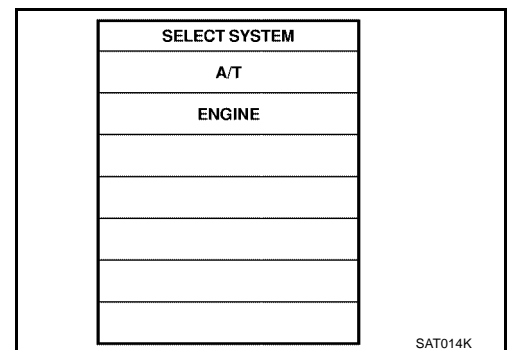

DTC P1815 MANUAL MODE SWITCH

Wiring Diagram — AT — MMSW

ECS00B11

AT-MMSW-01

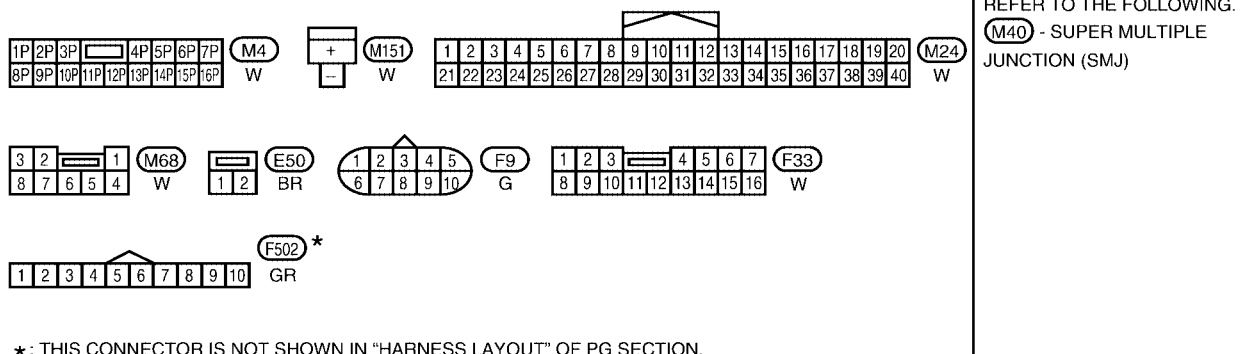
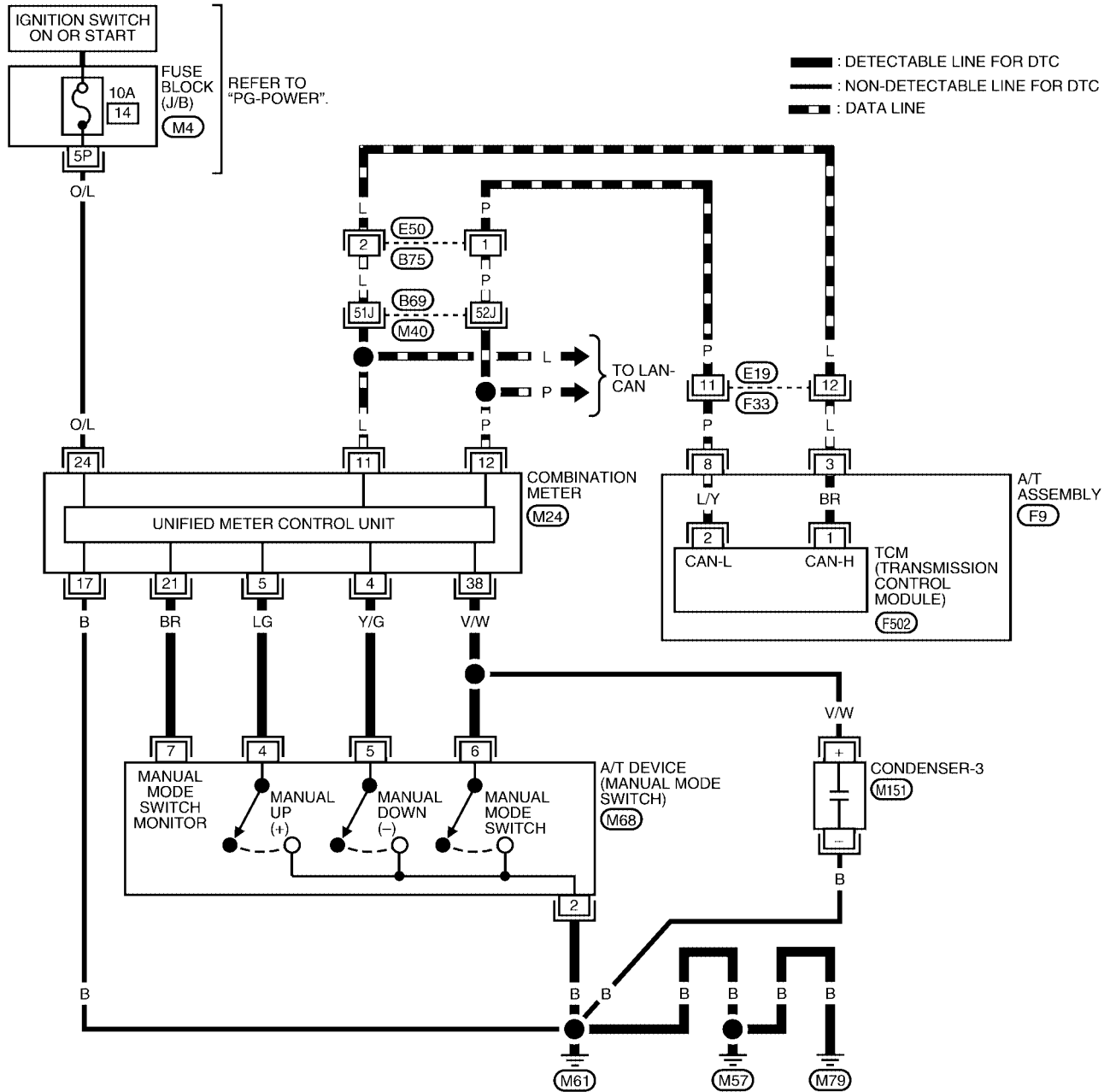

BCWA0339E

DTC P1815 MANUAL MODE SWITCH

ECS00B1J

Diagnostic Procedure

1. CHECK CAN COMMUNICATION LINE

Perform the self-diagnosis. Is a malfunction in the CAN communication indicated in the results?

Yes or No

- Yes >> Check CAN communication line. Refer to [AT-97, "DTC U1000 CAN COMMUNICATION LINE"](#) .
No >> GO TO 2.

2. CHECK MANUAL MODE SWITCH CIRCUIT

With CONSULT-II

1. Turn ignition switch "ON". (Do not start engine.)
2. Select "UNIFIED METER AND A/C AMP INPUT SIGNALS" in "DATA MONITOR" mode for "METER A/C AMP" with CONSULT-II.
3. Read out ON/OFF switching action of the "AT-M GEAR".

DATA MONITOR	
MONITOR	
AT-M IND	OFF
AT-M GEAR	OFF
P RANGE IND	ON
R RANGE IND	OFF
N RANGE IND	OFF
D RANGE IND	OFF

PKIA2062E

Without CONSULT-II

Drive vehicle in the manual mode, and confirm that the actual gear position and the meter's indication of the position mutually coincide when the selector lever is shifted to the "+" (up) or "-" (down) side (1st \leftrightarrow 5th gear).

OK or NG

- OK >> GO TO 6.
NG >> GO TO 3.

3. DETECT MALFUNCTIONING ITEM

Check the following items.

- Manual mode switch. Refer to [AT-164, "Component Inspection"](#) .
- Pin terminals for damage or loose connection with harness connector.
- Open circuit or short to ground or short to power in harness or connector for A/T device (manual mode switch).

OK or NG

- OK >> GO TO 4.
NG >> Repair or replace damaged parts.

4. CHECK TCM

Perform TCM input/output signal inspection. Refer to [AT-84, "TCM Input/Output Signal Reference Values"](#) .

OK or NG

- OK >> GO TO 6.
NG >> GO TO 5.

DTC P1815 MANUAL MODE SWITCH

5. DETECT MALFUNCTIONING ITEM

Check the following items:

- Power supply and ground circuit for TCM.
- The A/T assembly harness connector pin terminals for damage or loose connection with harness connector.

OK or NG

- OK >> Replace the transmission assembly. Refer to [AT-265, "Removal and Installation \(4x2\)"](#) , [AT-268, "Removal and Installation \(4x4\)"](#) .
- NG >> Repair or replace damaged parts.

6. CHECK DTC

Perform DTC Confirmation Procedure.

- Refer to [AT-161, "DTC Confirmation Procedure"](#) .

OK or NG

- OK >> **INSPECTION END**
- NG >> GO TO 4.

Component Inspection MANUAL MODE SWITCH

ECS00B1K

Check continuity between terminals.

Item	Position	Connector No.	Terminal No. (Unit side)	Continuity
Manual mode (select) switch	Manual	M34	2 - 6	Yes
UP switch	UP		2 - 4	
DOWN switch	DOWN		2 - 5	

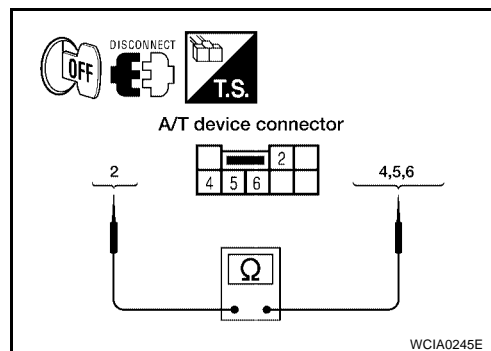

Position Indicator Lamp DIAGNOSTIC PROCEDURE

ECS00B1L

1. CHECK INPUT SIGNALS (WITH CONSULT-II)

Ⓟ With CONSULT-II

1. Start engine.
2. Select "MAIN SIGNALS" in "DATA MONITOR" mode for A/T with CONSULT-II and read out the value of "GEAR".
3. Drive vehicle in the manual mode, and confirm that the actual gear position and the meter's indication of the position mutually coincide when the select lever is shifted to the "+ (up)" or "- (down)" side (1st ⇔ 5th gear).

OK or NG

- OK >> **INSPECTION END**
- NG >> Check the following items.

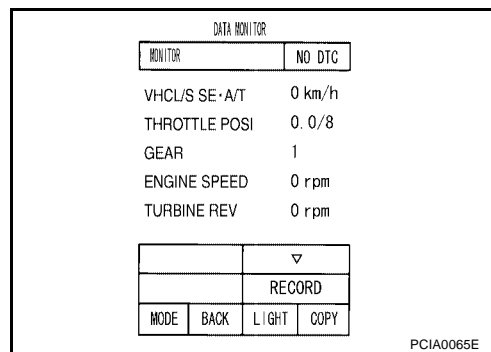

Position Indicator Lamp Symptom Chart

DTC P1815 MANUAL MODE SWITCH

Items	Presumed Location of Trouble	
The actual gear position does not change, or shifting into the manual mode is not possible (no gear shifting in the manual mode possible). The position indicator lamp is not indicated.	Manual mode switch Refer to AT-161, "DTC P1815 MANUAL MODE SWITCH" . A/T main system (Fail-safe function actuated) ● Refer to AT-87, "CONSULT-II SETTING PROCEDURE" .	A B
The actual gear position changes, but the position indicator lamp is not indicated.	Perform the self-diagnosis function. ● Refer to AT-87, "CONSULT-II SETTING PROCEDURE" .	AT
The actual gear position and the indication on the position indicator lamp do not coincide.	Perform the self-diagnosis function. ● Refer to AT-87, "CONSULT-II SETTING PROCEDURE" .	D
Only a specific position or positions is/are not indicated on the position indicator lamp.	Check the combination meter. Refer to DI-5, "COMBINATION METERS" .	E F G H I J K L M

DTC P1841 ATF PRESSURE SWITCH 1

DTC P1841 ATF PRESSURE SWITCH 1

PF:25240

Description

ECS00B1M

Fail-safe function to detect front brake clutch solenoid valve condition.

CONSULT-II Reference Value

ECS00B1N

Item name	Condition	Display value
ATF PRES SW 1	Front brake engaged. Refer to AT-18 , AT-20 .	ON
	Front brake disengaged. Refer to AT-18 , AT-20 .	OFF

On Board Diagnosis Logic

ECS00B1O

- This is not an OBD-II self-diagnostic item.
- Diagnostic trouble code "P1841 ATF PRES SW 1/CIRC" with CONSULT-II is detected when TCM detects that actual gear ratio is normal, and relation between gear position and condition of ATF pressure switch 1 is irregular during depressing accelerator pedal. (Other than during shift change)

Possible Cause

ECS00B1P

- ATF pressure switch 1
- Harness or connectors
(The switch circuit is open or shorted.)

DTC Confirmation Procedure

ECS00B1Q

CAUTION:

Always drive vehicle at a safe speed.

NOTE:

If "DTC Confirmation Procedure" has been previously performed, always turn ignition switch "OFF" and wait at least 10 seconds before performing the next test.

After the repair, perform the following procedure to confirm the malfunction is eliminated.

WITH CONSULT-II

1. Start engine.
2. Accelerate vehicle to maintain the following conditions.
ACCELE POS: 1.5/8 - 2.0/8
Selector lever: "D" position
Gear position: 3rd ⇒ 4th Gear (FR/B ON/OFF)
Driving location: Driving the vehicle uphill (increased engine load) will help maintain the driving conditions required for this test.
3. Perform step "2" again.
4. Turn ignition switch "OFF", then perform step "1" to "3" again.
5. Check "SELF-DIAG RESULTS" mode for "A/T" with CONSULT-II.
If DTC (P1841) is detected, go to [AT-167, "Diagnostic Procedure"](#) .
If DTC (P1757) is detected, go to [AT-146, "Diagnostic Procedure"](#) .

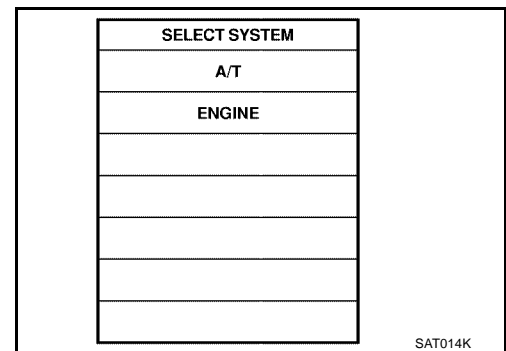

DTC P1841 ATF PRESSURE SWITCH 1

ECS00CCI

Diagnostic Procedure

1. CHECK INPUT SIGNAL

With CONSULT-II

1. Start engine.
2. Select "ECU INPUT SIGNALS" or "MAIN SIGNALS" in "DATA MONITOR" mode for "A/T" with CONSULT-II.
3. Drive vehicle in the "D" position (3rd ⇒ 4th gear), and confirm the ON/OFF actuation of the "ATF PRES SW 1".

Item name	Condition	Display value
ATF PRES SW 1	Front brake engaged. Refer to AT-18 , AT-20 .	ON
	Front brake disengaged. Refer to AT-18 , AT-20 .	OFF

DATA MONITOR	
MONITOR	NO. DTC
ATF PRES SW 1	OFF
ATF PRES SW 2	OFF
ATF PRES SW 3	OFF
ATF PRES SW 5	OFF
ATF PRES SW 6	OFF

Δ	▽		
RECORD			
MODE	BACK	LIGHT	COPY

PCIA0067E

OK or NG

- OK >> GO TO 4.
NG >> GO TO 2.

2. CHECK TCM POWER SUPPLY AND GROUND CIRCUIT

Check TCM power supply and ground circuit. Refer to [AT-174, "MAIN POWER SUPPLY AND GROUND CIRCUIT"](#) .

OK or NG

- OK >> GO TO 3.
NG >> Repair or replace damaged parts.

3. DETECT MALFUNCTIONING ITEM

Check the following items:

- The A/T assembly harness connector pin terminals for damage or loose connection with harness connector.

OK or NG

- OK >> Replace the control valve with TCM. Refer to [AT-250, "Control Valve With TCM and A/T Fluid Temperature Sensor 2"](#) .
NG >> Repair or replace damaged parts.

4. CHECK DTC

Perform "DTC Confirmation Procedure".

- Refer to [AT-166, "DTC Confirmation Procedure"](#) .

OK or NG

- OK >> **INSPECTION END**
NG >> GO TO 2.

DTC P1843 ATF PRESSURE SWITCH 3

DTC P1843 ATF PRESSURE SWITCH 3

PFPP:25240

Description

ECS00B1S

Fail-safe function to detect input clutch solenoid valve condition.

CONSULT-II Reference Value

ECS00B1T

Item name	Condition	Display value
ATF PRES SW 3	Input clutch engaged. Refer to AT-20 , AT-18 .	ON
	Input clutch disengaged. Refer to AT-20 , AT-18 .	OFF

On Board Diagnosis Logic

ECS00B1U

- This is not an OBD-II self-diagnostic item.
- Diagnostic trouble code "P1843 ATF PRES SW 3/CIRC" with CONSULT-II is detected when TCM detects that actual gear ratio is normal, and relation between gear position and condition of ATF pressure switch 3 is irregular during depressing accelerator pedal. (Other than during shift change)

Possible Cause

ECS00B1V

- ATF pressure switch 3
- Harness or connectors
(The switch circuit is open or shorted.)

DTC Confirmation Procedure

ECS00B1W

CAUTION:

Always drive vehicle at a safe speed.

NOTE:

If "DTC Confirmation Procedure" has been previously performed, always turn ignition switch "OFF" and wait at least 10 seconds before performing the next test.

After the repair, perform the following procedure to confirm the malfunction is eliminated.

WITH CONSULT-II

1. Start engine.
2. Accelerate vehicle to maintain the following conditions.
ACCELE POS: 1.5/8 - 2.0/8
Selector lever: "D" position
Gear position: 3rd ⇒ 4th Gear (I/C ON/OFF)
Driving location: Driving the vehicle uphill (increased engine load) will help maintain the driving conditions required for this test.
3. Perform step "2" again.
4. Turn ignition switch "OFF", then perform step "1" to "3" again.
5. Check "SELF-DIAG RESULTS" mode for "A/T" with CONSULT-II.
If DTC (P1843) is detected, go to [AT-169, "Diagnostic Procedure"](#) .
If DTC (P1752) is detected, go to [AT-142, "Diagnostic Procedure"](#) .

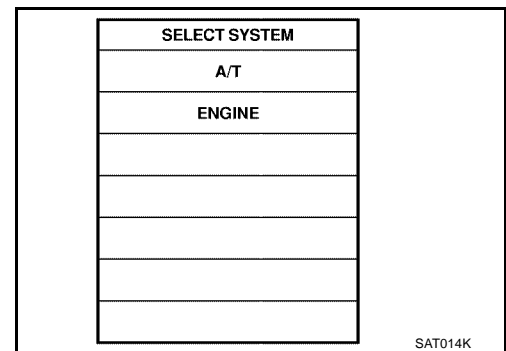

DTC P1843 ATF PRESSURE SWITCH 3

ECS00CCJ

Diagnostic Procedure

1. CHECK INPUT SIGNAL

With CONSULT-II

1. Start engine.
2. Select "ECU INPUT SIGNALS" or "MAIN SIGNALS" in "DATA MONITOR" mode for "A/T" with CONSULT-II.
3. Drive vehicle in the "D" position (3rd ⇒ 4th gear), and confirm the ON/OFF actuation of the "ATF PRES SW 3".

DATA MONITOR	
MONITOR	NO. DTC
ATF PRES SW 1	OFF
ATF PRES SW 2	OFF
ATF PRES SW 3	OFF
ATF PRES SW 5	OFF
ATF PRES SW 6	OFF

Δ	▽
RECORD	
MODE	BACK
LIGHT	COPY

PCIA0067E

Item name	Condition	Display value
ATF PRES SW 3	Input clutch engaged. Refer to AT-18 , AT-20 .	ON
	Input clutch disengaged. Refer to AT-18 , AT-20 .	OFF

OK or NG

- OK >> GO TO 4.
NG >> GO TO 2.

2. CHECK TCM POWER SUPPLY AND GROUND CIRCUIT

Check TCM power supply and ground circuit. Refer to [AT-174, "MAIN POWER SUPPLY AND GROUND CIRCUIT"](#) .

OK or NG

- OK >> GO TO 3.
NG >> Repair or replace damaged parts.

3. DETECT MALFUNCTIONING ITEM

Check the following items:

- The A/T assembly harness connector pin terminals for damage or loose connection with harness connector.

OK or NG

- OK >> Replace the control valve with TCM. Refer to [AT-250, "Control Valve With TCM and A/T Fluid Temperature Sensor 2"](#) .
NG >> Repair or replace damaged parts.

4. CHECK DTC

Perform "DTC Confirmation Procedure".

- Refer to [AT-168, "DTC Confirmation Procedure"](#) .

OK or NG

- OK >> **INSPECTION END**
NG >> GO TO 2.

DTC P1845 ATF PRESSURE SWITCH 5

DTC P1845 ATF PRESSURE SWITCH 5

PF2:25240

Description

ECS00B1Y

Fail-safe function to detect direct clutch solenoid valve condition.

CONSULT-II Reference Value

ECS00B1Z

Item name	Condition	Display value
ATF PRES SW 5	Direct clutch engaged. Refer to AT-20 , AT-18 .	ON
	Direct clutch disengaged. Refer to AT-20 , AT-18 .	OFF

On Board Diagnosis Logic

ECS00B20

- This is not an OBD-II self-diagnostic item.
- Diagnostic trouble code "P1845 ATF PRES SW 5/CIRC" with CONSULT-II is detected when TCM detects that actual gear ratio is normal, and relation between gear position and condition of ATF pressure switch 5 is irregular during depressing accelerator pedal. (Other than during shift change)

Possible Cause

ECS00B21

- ATF pressure switch 5
- Harness or connectors
(The switch circuit is open or shorted.)

DTC Confirmation Procedure

ECS00B22

CAUTION:

Always drive vehicle at a safe speed.

NOTE:

If "DTC Confirmation Procedure" has been previously performed, always turn ignition switch "OFF" and wait at least 10 seconds before performing the next test.

After the repair, perform the following procedure to confirm the malfunction is eliminated.

WITH CONSULT-II

1. Start engine.
2. Accelerate vehicle to maintain the following conditions.
ACCELE POS: 1.5/8 - 2.0/8
Selector lever: "D" position
Gear position: 1st ⇒ 2nd Gear (D/C ON/OFF)
Driving location: Driving the vehicle uphill (increased engine load) will help maintain the driving conditions required for this test.
3. Perform step "2" again.
4. Turn ignition switch "OFF", then perform step "1" to "3" again.
5. Check "SELF-DIAG RESULTS" mode for "A/T" with CONSULT-II.
If DTC (P1845) is detected, go to [AT-171, "Diagnostic Procedure"](#) .
If DTC (P1762) is detected, go to [AT-150, "Diagnostic Procedure"](#) .

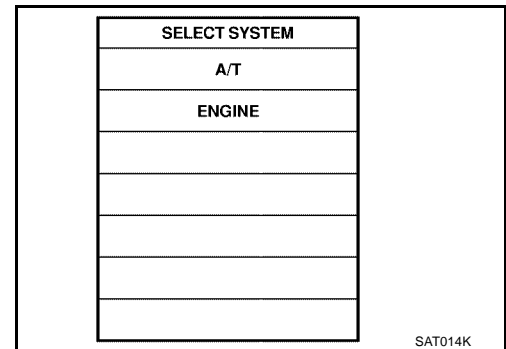

DTC P1845 ATF PRESSURE SWITCH 5

EC500CCK

Diagnostic Procedure

1. CHECK INPUT SIGNAL

With CONSULT-II

1. Start engine.
2. Select "ECU INPUT SIGNALS" or "MAIN SIGNALS" in "DATA MONITOR" mode for "A/T" with CONSULT-II.
3. Drive vehicle in the "D" position (1st ⇒ 2nd gear), and confirm the ON/OFF actuation of the "ATF PRES SW 5".

DATA MONITOR	
MONITOR	NO. DTC
ATF PRES SW 1	OFF
ATF PRES SW 2	OFF
ATF PRES SW 3	OFF
ATF PRES SW 5	OFF
ATF PRES SW 6	OFF

Δ	▽		
RECORD			
MODE	BACK	LIGHT	COPY

PCIA0067E

Item name	Condition	Display value
ATF PRES SW 5	Direct clutch engaged. Refer to AT-18 , AT-20 .	ON
	Direct clutch disengaged. Refer to AT-18 , AT-20 .	OFF

OK or NG

- OK >> GO TO 4.
- NG >> GO TO 2.

2. CHECK TCM POWER SUPPLY AND GROUND CIRCUIT

Check TCM power supply and ground circuit. Refer to [AT-174](#), "[MAIN POWER SUPPLY AND GROUND CIRCUIT](#)".

OK or NG

- OK >> GO TO 3.
- NG >> Repair or replace damaged parts.

3. DETECT MALFUNCTIONING ITEM

Check the following items:

- The A/T assembly harness connector pin terminals for damage or loose connection with harness connector.

OK or NG

- OK >> Replace the control valve with TCM. Refer to [AT-250](#), "[Control Valve With TCM and A/T Fluid Temperature Sensor 2](#)".
- NG >> Repair or replace damaged parts.

4. CHECK DTC

Perform "DTC Confirmation Procedure".

- Refer to [AT-170](#), "[DTC Confirmation Procedure](#)".

OK or NG

- OK >> **INSPECTION END**
- NG >> GO TO 2.

DTC P1846 ATF PRESSURE SWITCH 6

DTC P1846 ATF PRESSURE SWITCH 6

PF:25240

Description

ECS00B24

Fail-safe function to detect high & low reverse clutch solenoid valve condition.

CONSULT-II Reference Value

ECS00B25

Item name	Condition	Display value
ATF PRES SW 6	High and low reverse clutch engaged. Refer to AT-20 , AT-18 .	ON
	High and low reverse clutch disengaged. Refer to AT-20 , AT-18 .	OFF

On Board Diagnosis Logic

ECS00B26

- This is not an OBD-II self-diagnostic item.
- Diagnostic trouble code "P1846 ATF PRES SW 6/CIRC" with CONSULT-II is detected when TCM detects that actual gear ratio is normal, and relation between gear position and condition of ATF pressure switch 6 is irregular during depressing accelerator pedal. (Other than during shift change)

Possible Cause

ECS00B27

- ATF pressure switch 6
- Harness or connectors
(The switch circuit is open or shorted.)

DTC Confirmation Procedure

ECS00B28

CAUTION:

Always drive vehicle at a safe speed.

NOTE:

If "DTC Confirmation Procedure" has been previously performed, always turn ignition switch "OFF" and wait at least 10 seconds before performing the next test.

After the repair, perform the following procedure to confirm the malfunction is eliminated.

WITH CONSULT-II

1. Start engine.
2. Accelerate vehicle to maintain the following conditions.
ACCELE POS: 1.5/8 - 2.0/8
Selector lever: "D" position
Gear position: 2nd ⇒ 3rd Gear (HLR/C ON/OFF)
Driving location: Driving the vehicle uphill (increased engine load) will help maintain the driving conditions required for this test.
3. Perform step "2" again.
4. Turn ignition switch "OFF", then perform step "1" to "3" again.
5. Check "SELF-DIAG RESULTS" mode for "A/T" with CONSULT-II.
If DTC (P1846) is detected, go to [AT-173, "Diagnostic Procedure"](#) .
If DTC (P1767) is detected, go to [AT-154, "Diagnostic Procedure"](#) .

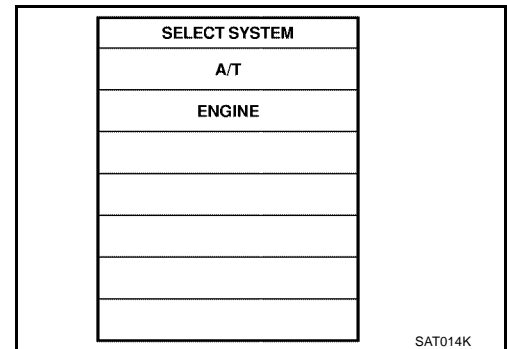

DTC P1846 ATF PRESSURE SWITCH 6

ECS00CCL

Diagnostic Procedure

1. CHECK INPUT SIGNAL

With CONSULT-II

1. Start the engine.
2. Select "ECU INPUT SIGNALS" or "MAIN SIGNALS" in "DATA MONITOR" mode for "A/T" with CONSULT-II.
3. Drive vehicle in the "D" position (2nd ⇒ 3rd gear), and confirm the ON/OFF actuation of the "ATF PRES SW 6".

Item name	Condition	Display value
ATF PRES SW 6	High and low reverse clutch engaged. Refer to AT-18 , AT-20 .	ON
	High and low reverse clutch disengaged Refer to AT-18 , AT-20 .	OFF

DATA MONITOR	
MONITOR	NO. DTC
ATF PRES SW 1	OFF
ATF PRES SW 2	OFF
ATF PRES SW 3	OFF
ATF PRES SW 5	OFF
ATF PRES SW 6	OFF

Δ	▽		
RECORD			
MODE	BACK	LIGHT	COPY

PCIA0067E

OK or NG

- OK >> GO TO 4.
- NG >> GO TO 2.

2. CHECK TCM POWER SUPPLY AND GROUND CIRCUIT

Check TCM power supply and ground circuit. Refer to [AT-174](#), "[MAIN POWER SUPPLY AND GROUND CIRCUIT](#)".

OK or NG

- OK >> GO TO 3.
- NG >> Repair or replace damaged parts.

3. DETECT MALFUNCTIONING ITEM

Check the following items:

- The A/T assembly harness connector pin terminals for damage or loose connection with harness connector.

OK or NG

- OK >> Replace the control valve with TCM. Refer to [AT-250](#), "[Control Valve With TCM and A/T Fluid Temperature Sensor 2](#)".
- NG >> Repair or replace damaged parts.

4. CHECK DTC

Perform "DTC Confirmation Procedure".

- Refer to [AT-172](#), "[DTC Confirmation Procedure](#)".

OK or NG

- OK >> **INSPECTION END**
- NG >> GO TO 2.

MAIN POWER SUPPLY AND GROUND CIRCUIT

PPF:00100

ECS00CCM

MAIN POWER SUPPLY AND GROUND CIRCUIT

Wiring Diagram — AT — MAIN

AT-MAIN-01

REFER TO "PG-POWER".

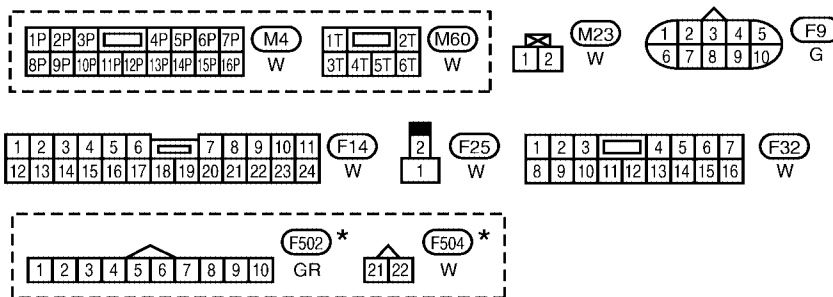
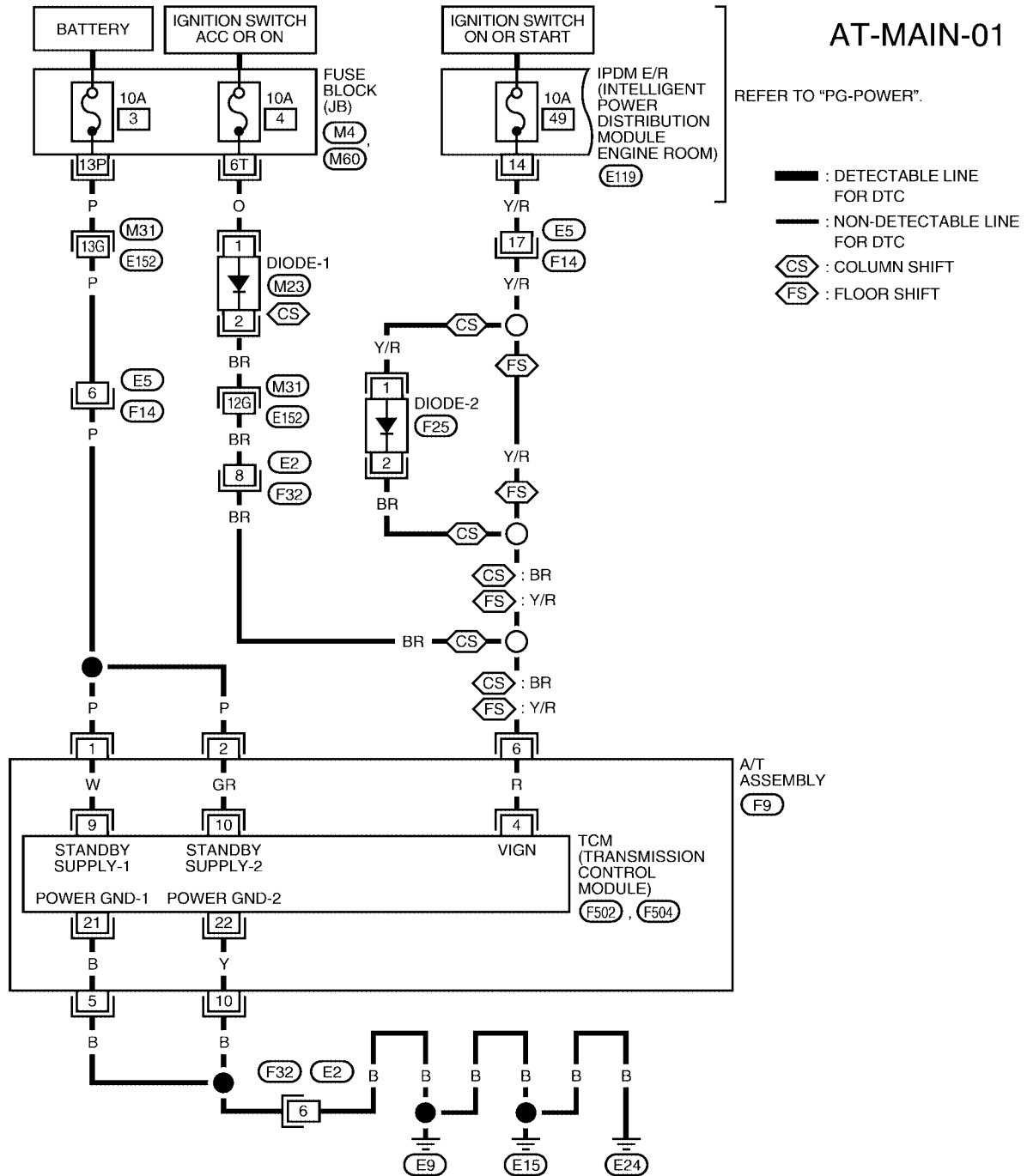

REFER TO THE FOLLOWING.

M31 - SUPER MULTIPLE JUNCTION (SMJ)



E119 - IPDM E/R (INTELLIGENT POWER DISTRIBUTION MODULE ENGINE ROOM)

* : THIS CONNECTOR IS NOT SHOWN IN "HARNESS LAYOUT" OF PG SECTION.

BCWA0382E

MAIN POWER SUPPLY AND GROUND CIRCUIT

TCM terminals and data are reference value. Measured between each terminal and ground.

Terminal	Wire color	Item	Condition	Data (Approx.)
1	P	Power supply (Memory back-up)	Always	Battery voltage
2	P	Power supply (Memory back-up)	Always	Battery voltage
5	B	Ground	Always	0V
6	BR *1 Y/R *2	Power supply		Battery voltage
				0V
10	B	Ground	Always	0V

*1: Column shift

*2: Floor shift

Diagnostic Procedure

ECS00CCN

1. CHECK TCM POWER SOURCE STEP 1

- Turn ignition switch OFF.
- Disconnect A/T assembly harness connector.
- Check voltage between A/T assembly harness connector terminals and ground.

Item	Connector	Terminal (Wire color)	Voltage
TCM	F9	1 (P) - Ground	Battery voltage
		2 (P) - Ground	
		6 (BR *1 or Y/R *2) - Ground	0V

*1: Column shift

*2: Floor shift

OK or NG

- OK >> GO TO 2.
NG >> GO TO 3.

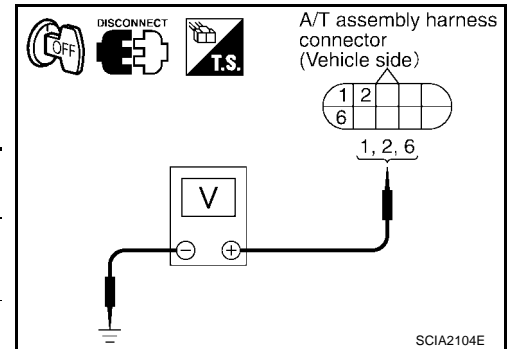

MAIN POWER SUPPLY AND GROUND CIRCUIT

2. CHECK TCM POWER SOURCE STEP 2

1. Disconnect A/T assembly harness connector.
2. Turn ignition switch ON. (Do not start engine.)
3. Check voltage between A/T assembly harness connector terminals and ground.

Item	Connector	Terminal (Wire color)	Voltage
TCM	F44	1 (P) - Ground	Battery voltage
		2 (P) - Ground	
		6 (BR *1 or Y/R *2) - Ground	

*1: Column shift

*2: Floor shift

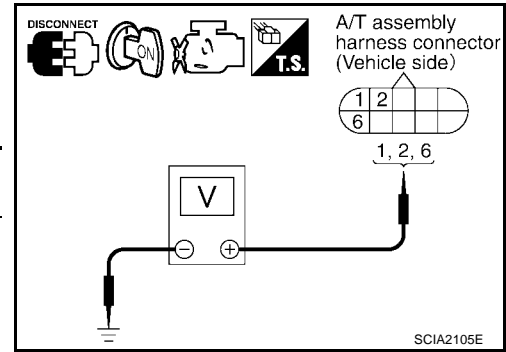

OK or NG

- OK >> GO TO 4.
- NG >> GO TO 3.

3. DETECT MALFUNCTIONING ITEM

Check the following items:

- Harness for short or open between battery and A/T assembly harness connector terminals 1, 2
- Harness for short or open between ignition switch and A/T assembly harness connector terminal 6
- 10A fuse [No. 3, 4, located in the fuse block (J/B)] and 10A fuse (No. 49, located in the IPDM E/R)
- Ignition switch, Refer to [PG-4, "POWER SUPPLY ROUTING CIRCUIT"](#).

OK or NG

- OK >> GO TO 4.
- NG >> Repair or replace damaged parts.

4. CHECK TCM GROUND CIRCUIT

1. Turn ignition switch OFF.
2. Disconnect A/T assembly harness connector.
3. Check continuity between A/T assembly harness connector terminals and ground.

Continuity should exist.

If OK, check harness for short to ground and short to power.

OK or NG

- OK >> GO TO 5.
- NG >> Repair open circuit or short to ground or short to power in harness or connectors.

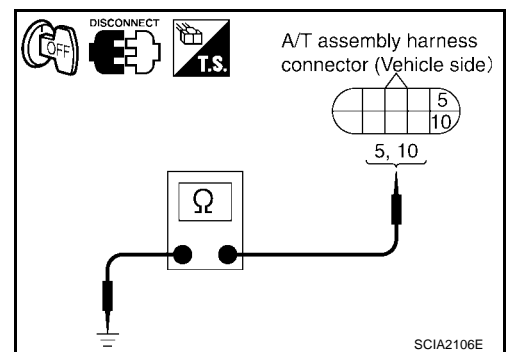

5. DETECT MALFUNCTIONING ITEM

Check the following items:

- The A/T assembly harness connector terminals for damage or loose connection with harness connector.

OK or NG

- OK >> GO TO 6.
- NG >> Repair or replace damaged parts.

MAIN POWER SUPPLY AND GROUND CIRCUIT

6. PERFORM SELF-DIAGNOSIS

Perform self-diagnosis. Refer to [AT-87, "SELF-DIAGNOSTIC RESULT MODE"](#) .

OK or NG

OK >> **INSPECTION END**

NG-1 >> Self-diagnosis does not activate: GO TO 7.

NG-2 >> DTC is displayed: Check the malfunctioning system. Refer to [AT-87, "SELF-DIAGNOSTIC RESULT MODE"](#) .

7. CHECK TERMINAL CORD ASSEMBLY

1. Remove control valve with TCM. Refer to [AT-250, "Control Valve With TCM and A/T Fluid Temperature Sensor 2"](#) .
2. Disconnect A/T assembly harness connector and TCM connector.
3. Check continuity between A/T assembly harness connector terminals and TCM connector terminals.

Item	Connector	Terminal (Wire color)	Continuity
A/T assembly harness connector	F9	1 (W)	Yes
TCM connector	F502	9 (W)	
A/T assembly harness connector	F9	2 (GR)	Yes
TCM connector	F502	10 (GR)	
A/T assembly harness connector	F9	6 (R)	Yes
TCM connector	F502	4 (R)	

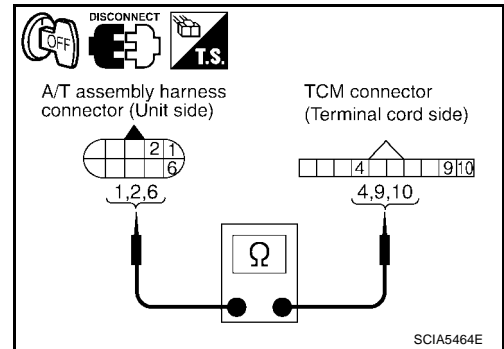

4. Check continuity between A/T assembly harness connector terminals and TCM connector terminals.

Item	Connector	Terminal (Wire color)	Continuity
A/T assembly harness connector	F9	5 (B)	Yes
TCM connector	F504	21 (B)	
A/T assembly harness connector	F9	10 (Y)	Yes
TCM connector	F504	22 (Y)	

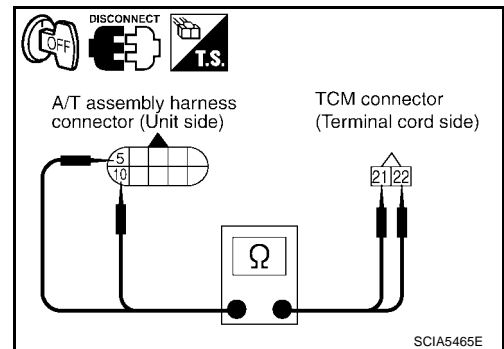

5. If OK, check harness for short to ground and short to power.

OK or NG

OK >> Replace the control valve with TCM. Refer to [AT-250, "Control Valve With TCM and A/T Fluid Temperature Sensor 2"](#) .

NG >> Replace open circuit or short to ground and short to power in harness or connectors.

TOW MODE SWITCH

TOW MODE SWITCH

PF2:25129

Description

ECS00B2A

When tow mode switch is "ON", tow mode switch signals are sent to TCM from combination meter by CAN communication line. Then it's a tow mode condition.

TOW MODE SWITCH

Wiring Diagram — AT — TMSW

ECS00CCS

AT-TMSW-01

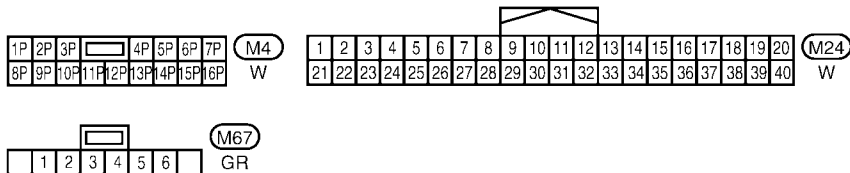
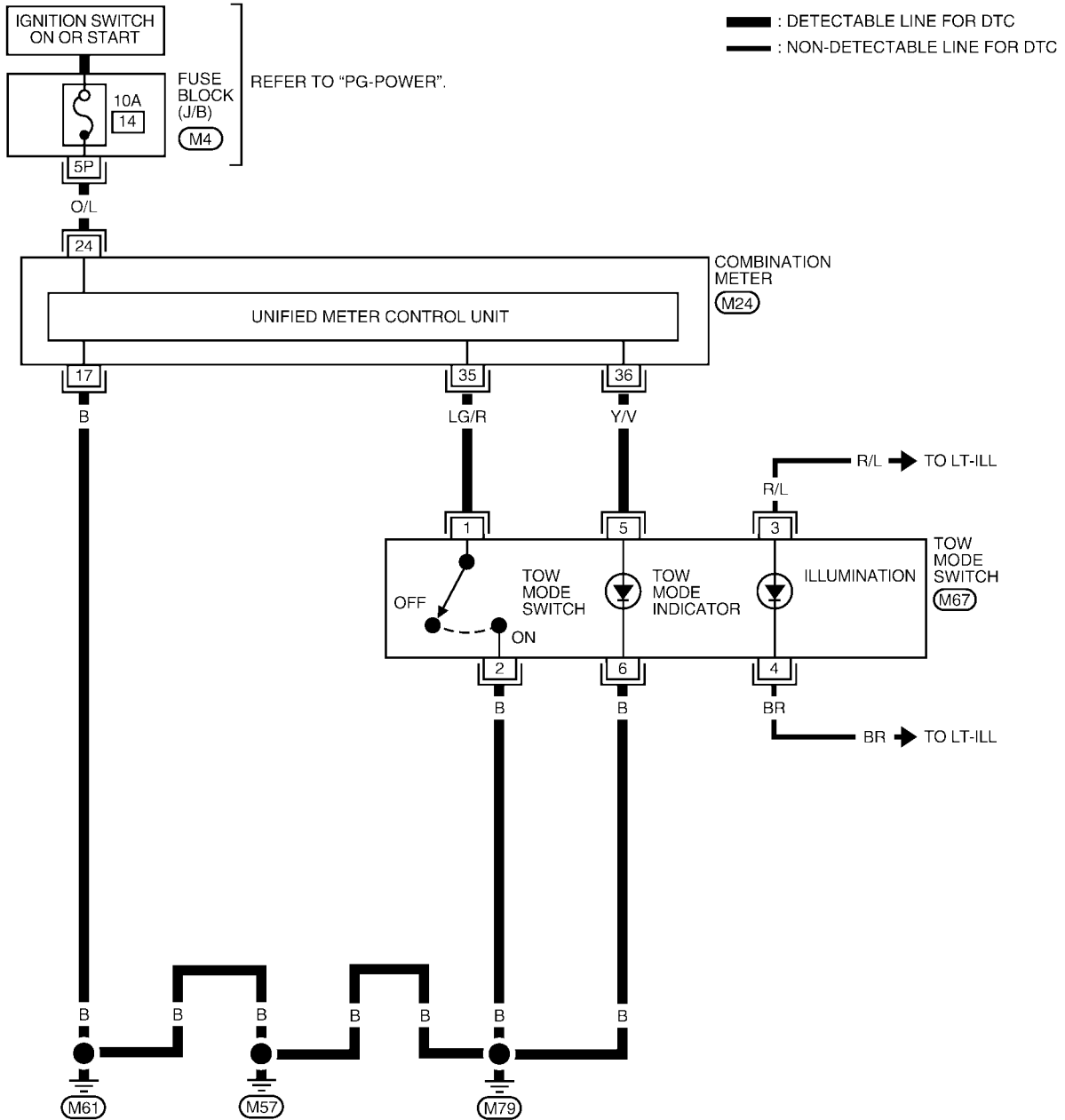

BCWA0383E

TOW MODE SWITCH

ECS00B2B

Diagnostic Procedure

1. CHECK CAN COMMUNICATION LINE

Perform the self-diagnosis. Refer to [AT-87, "SELF-DIAGNOSTIC RESULT MODE"](#).

Is any malfunction in the CAN communication indicated in the results?

- YES >> Check CAN communication line. Refer to [AT-97, "DTC U1000 CAN COMMUNICATION LINE"](#).
NO >> GO TO 2.

2. CHECK POWER SOURCE

1. Turn ignition switch "ON". (Do not start engine.)
2. Check the voltage between tow mode switch connector terminal 1 and ground.

Condition	Tow mode switch	Data (Approx.)
When ignition switch is turned to "ON"	ON	0V
	OFF	Battery voltage

OK or NG

- OK >> **INSPECTION END**
NG >> GO TO 3.

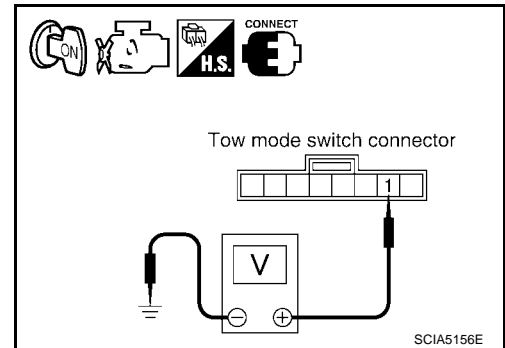

3. CHECK TOW MODE SWITCH

1. Turn ignition switch "OFF".
2. Disconnect tow mode switch connector.
3. Check continuity between tow mode switch connector M254 terminals 1 and 2.

Condition	Continuity
Tow mode switch "ON"	Yes
Tow mode switch "OFF"	No

OK or NG

- OK >> GO TO 4.
NG >> Repair or replace tow mode switch.

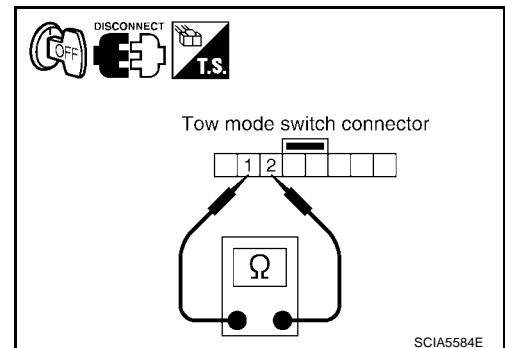

4. DETECT MALFUNCTIONING ITEM

Check the following items. If any items are damaged, repair or replace damaged parts.

- Harness for short or open between combination meter connector terminal 35 and tow mode switch connector terminal 1.
- Harness for short or open between tow mode switch connector terminal 2 and ground.

OK or NG

- OK >> GO TO 5.
NG >> Repair or replace damaged parts.

5. CHECK COMBINATION METER

Check the combination meter. Refer to [DI-5, "COMBINATION METERS"](#).

OK or NG

- OK >> **INSPECTION END**
NO >> Repair or replace damaged parts.

CLOSED THROTTLE POSITION AND WIDE OPEN THROTTLE POSITION CIRCUIT

CLOSED THROTTLE POSITION AND WIDE OPEN THROTTLE POSITION CIRCUIT

PF1:18002

CONSULT-II Reference Value

ECS00B2C

Item name	Condition	Display value
CLSD THL POS	Released accelerator pedal.	ON
	Fully depressed accelerator pedal.	OFF
W/O THL POS	Fully depressed accelerator pedal.	ON
	Released accelerator pedal.	OFF

Diagnostic Procedure

ECS00B2D

1. CHECK CAN COMMUNICATION LINE

Perform the self-diagnosis. Refer to [AT-87, "SELF-DIAGNOSTIC RESULT MODE"](#).

Is a malfunction in the CAN communication indicated in the results?

- YES >> Check CAN communication line. Refer to [AT-97, "DTC U1000 CAN COMMUNICATION LINE"](#).
 NO >> GO TO 2.

2. CHECK THROTTLE POSITION SIGNAL CIRCUIT

With CONSULT-II

- Turn ignition switch "ON". (Do not start engine.)
- Select "ECU INPUT SIGNALS" in "DATA MONITOR" mode for "A/T" with CONSULT-II.
- Depress accelerator pedal and read out the value of "CLSD THL POS" and "W/O THL POS".

DATA MONITOR	
MONITOR	NO DTC
ACCELE POSI	0.0/8
THROTTLE POSI	0.0/8
CLSD THL POS	ON
W/O THL POS	OFF
BRAKE SW	OFF
▼	
RECORD	
MODE	BACK
LIGHT	COPY

PCIA0070E

Accelerator Pedal Operation	Monitor Item	
	CLSD THL POS	W/O THL POS
Released	ON	OFF
Fully depressed	OFF	ON

OK or NG

- OK >> **INSPECTION END**
 NG >> Check the following items. If NG, repair or replace damaged parts.
- Perform the self-diagnosis for "ENGINE" with CONSULT-II.
 - Open circuit or short to ground or short to power in harness or connectors.
 - Pin terminals for damage or loose connection with harness connector.

BRAKE SIGNAL CIRCUIT

BRAKE SIGNAL CIRCUIT

PF2:25320

CONSULT-II Reference Value

ECS00B2E

Item name	Condition	Display value
BRAKE SW	Depressed brake pedal.	ON
	Released brake pedal.	OFF

Diagnostic Procedure

ECS00B2F

1. CHECK CAN COMMUNICATION LINE

Perform the self-diagnosis. Refer to [AT-87, "SELF-DIAGNOSTIC RESULT MODE"](#).

Is a malfunction in the CAN communication indicated in the results?

- YES >> Check CAN communication line. Refer to [AT-97, "DTC U1000 CAN COMMUNICATION LINE"](#).
 NO >> GO TO 2.

2. CHECK STOP LAMP SWITCH CIRCUIT

Ⓜ With CONSULT-II

- Turn ignition switch "ON". (Do not start engine.)
- Select "ECU INPUT SIGNALS" in "DATA MONITOR" mode for "A/T" with CONSULT-II.
- Read out ON/OFF switching action of the "BRAKE SW".

OK or NG

- OK >> **INSPECTION END**
 NG >> GO TO 3.

DATA MONITOR	
MONITOR	NO DTC
ACCELE POSI	0.0/8
THROTTLE POSI	0.0/8
CLSD THL POS	ON
W/O THL POS	OFF
BRAKE SW	OFF
▽	
RECORD	
MODE	BACK LIGHT COPY

PCIA0070E

3. CHECK STOP LAMP SWITCH

Check continuity between stop lamp switch harness connector terminals 1 and 2.

Condition	Continuity
When brake pedal is depressed	Yes
When brake pedal is released	No

Check stop lamp switch after adjusting brake pedal — refer to [BR-6, "BRAKE PEDAL"](#).

OK or NG

- OK >> **INSPECTION END**
 NG >> Check the following items. If NG, repair or replace damaged parts.
- Harness for short or open between battery and stop lamp switch.
 - Harness for short or open between stop lamp switch and combination meter.

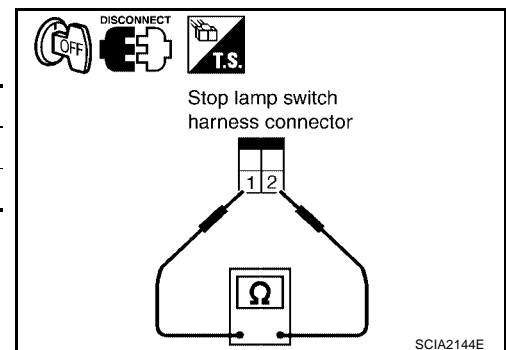

TROUBLE DIAGNOSIS FOR SYMPTOMS

PF0:0007

TROUBLE DIAGNOSIS FOR SYMPTOMS

Wiring Diagram — AT — NONDTC

EC500CCT

AT-NONDTC-01

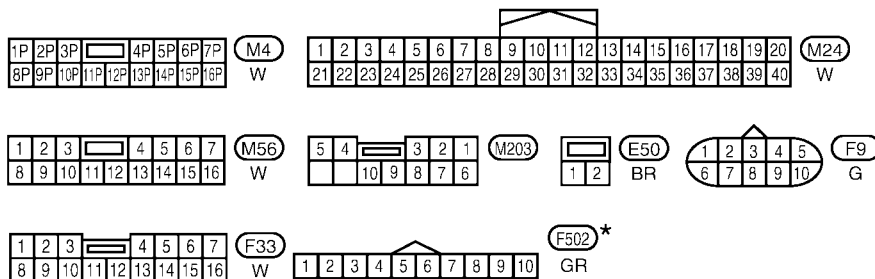
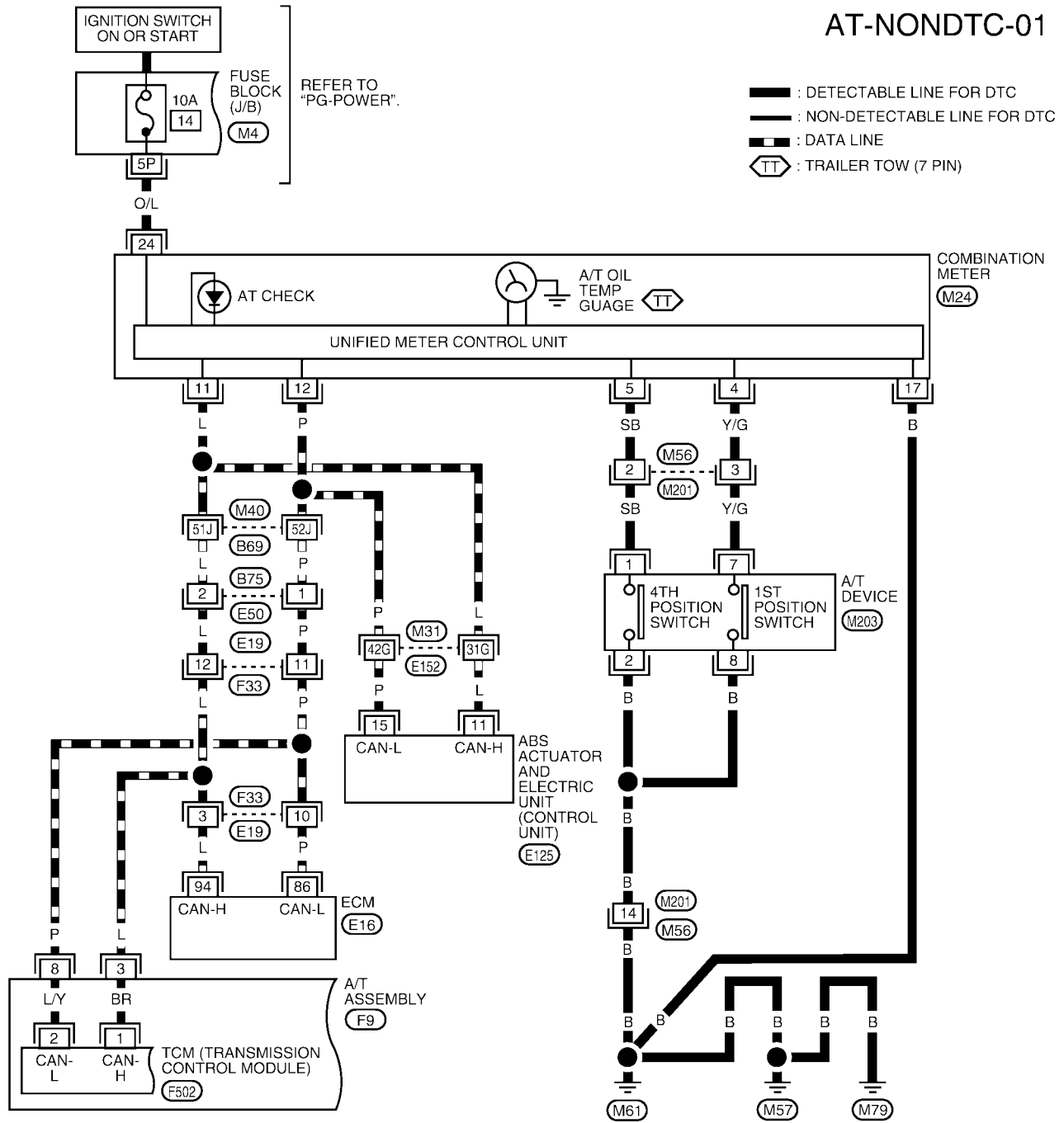

REFER TO THE FOLLOWING.
 (E16), (E125) - ELECTRICAL UNITS
 (M31), (M40) - SUPER MULTIPLE JUNCTION (SMJ)

*: THIS CONNECTOR IS NOT SHOWN IN "HARNESS LAYOUT" OF PG SECTION.

BCWA0411E

TROUBLE DIAGNOSIS FOR SYMPTOMS

AT-NONDTC-02

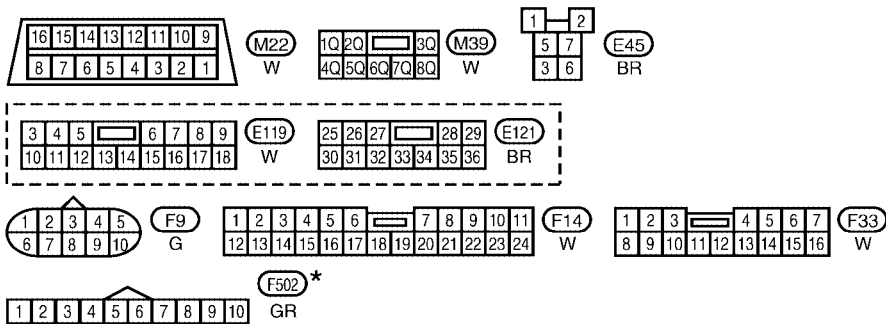
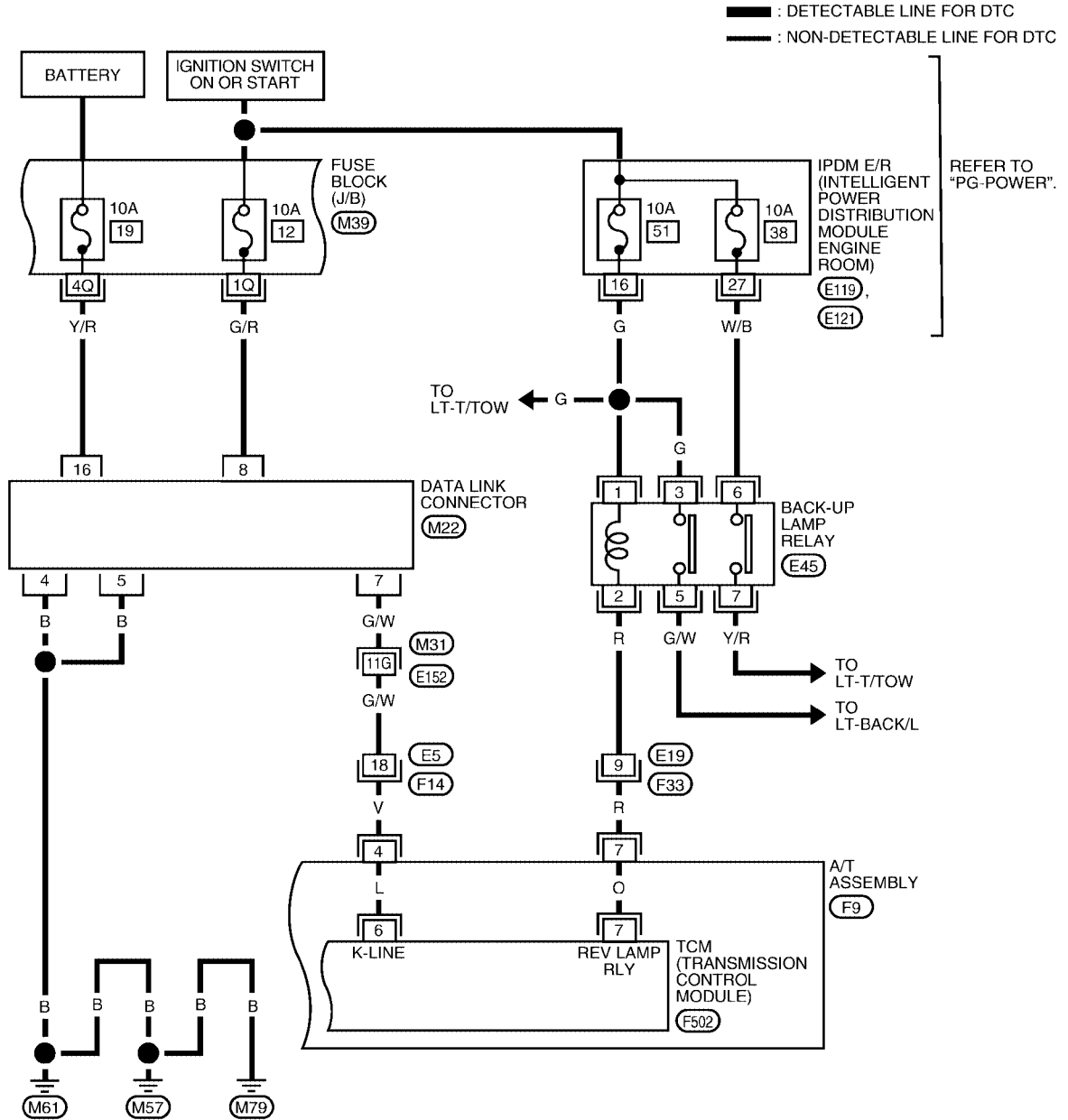

* : THIS CONNECTOR IS NOT SHOWN IN "HARNESS LAYOUT" OF PG SECTION.

REFER TO THE FOLLOWING.
(M31) - SUPER MULTIPLE JUNCTION (SMJ)

BCWA0326E

TROUBLE DIAGNOSIS FOR SYMPTOMS

AT-NONDTC-03

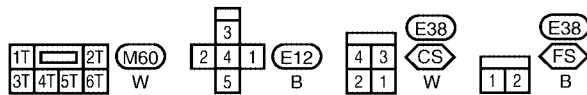
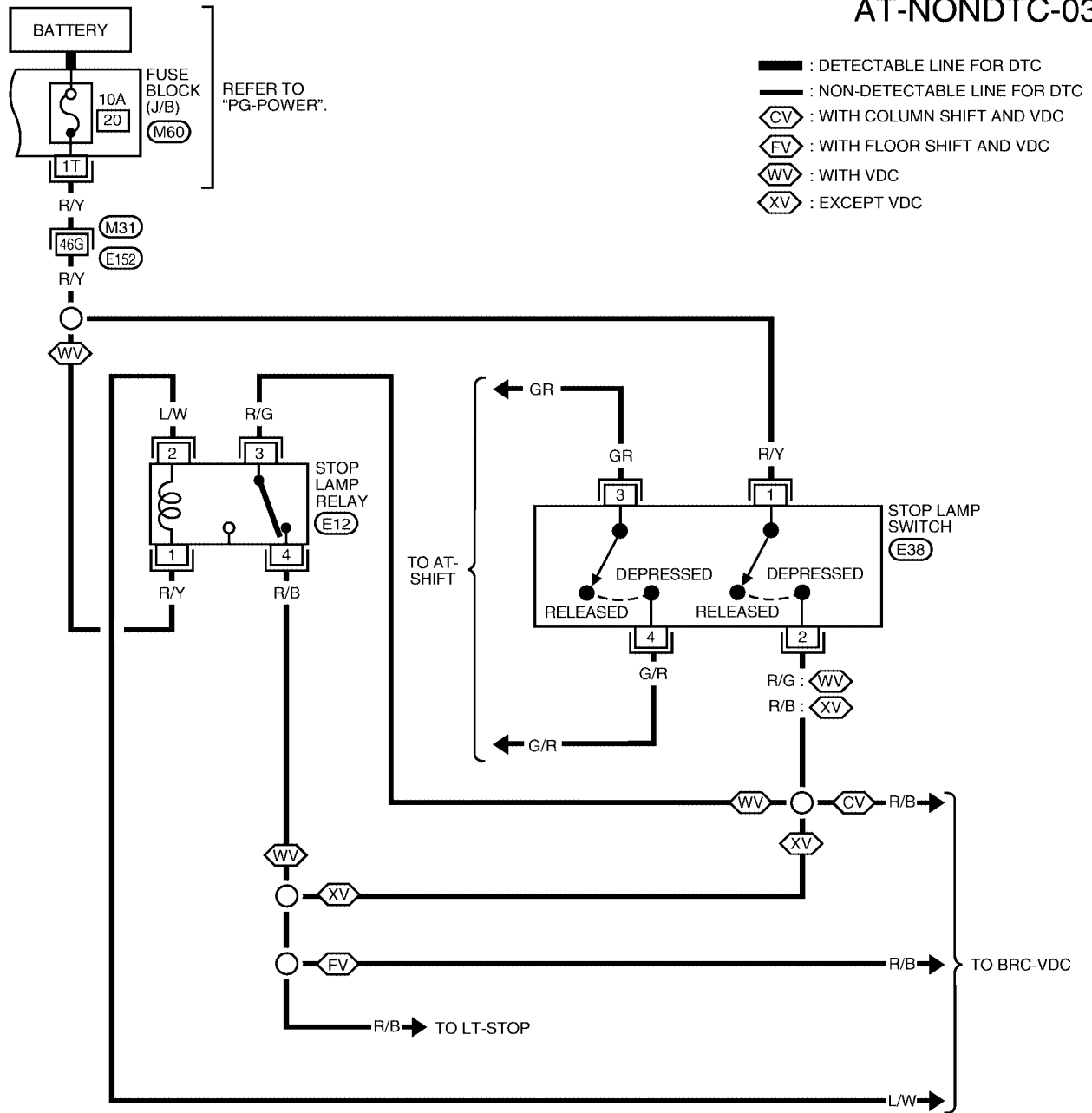

REFER TO THE FOLLOWING.
M31 - SUPER MULTIPLE JUNCTION (SMJ)

TROUBLE DIAGNOSIS FOR SYMPTOMS

TCM terminals and data are reference value. Measured between each terminal and ground.

Terminal	Wire color	Item	Condition	Data (Approx.)
3	L	CAN-H	-	-
4	V	K-line (CONSULT-II signal)	The terminal is connected to the data link connector for CONSULT-II	-
7	R	Back-up lamp relay	 Selector lever in "R" position.	0V
			Selector lever in other positions.	Battery voltage
8	P	CAN-L	-	-

AT CHECK Indicator Lamp does not come on SYMPTOM:

ECS00B2G

AT CHECK indicator lamp does not come on for about 2 seconds when turning ignition switch to "ON".

DIAGNOSTIC PROCEDURE

1. CHECK CAN COMMUNICATION LINE

Perform the self-diagnosis. Refer to [AT-87, "SELF-DIAGNOSTIC RESULT MODE"](#) .

Is a malfunction in the CAN communication indicated in the results?

- YES >> Check CAN communication line. Refer to [AT-97, "DTC U1000 CAN COMMUNICATION LINE"](#) .
- NO >> GO TO 2.

2. CHECK A/T CHECK INDICATOR LAMP CIRCUIT

Check the combination meter. Refer to [DI-5, "COMBINATION METERS"](#) .

OK or NG

- OK >> GO TO 3.
- NG >> Repair or replace damaged parts.

3. CHECK TCM POWER SUPPLY AND GROUND CIRCUIT

Check TCM power supply and ground circuit. Refer to [AT-174, "MAIN POWER SUPPLY AND GROUND CIRCUIT"](#) .

OK or NG

- OK >> **INSPECTION END**
- NG >> Repair or replace damaged parts.

Engine Cannot Be Started In "P" or "N" Position SYMPTOM:

ECS00B2H

- Engine cannot be started with selector lever in "P" or "N" position.
- Engine can be started with selector lever in "D" or "R" position.

DIAGNOSTIC PROCEDURE

1. CHECK SELF-DIAGNOSIS RESULTS

Perform self-diagnosis.

Do the self-diagnosis results indicate PNP switch?

- Yes >> Check the malfunctioning system. Refer to [AT-105, "DTC P0705 PARK/NEUTRAL POSITION SWITCH"](#) .
- No >> GO TO 2.

TROUBLE DIAGNOSIS FOR SYMPTOMS

2. CHECK CONTROL CABLE

Check the control cable.

- Refer to [AT-238, "Checking of A/T Position"](#) .

OK or NG

OK >> GO TO 3.

NG >> Adjust control cable. Refer to [AT-238, "Adjustment of A/T Position"](#) .

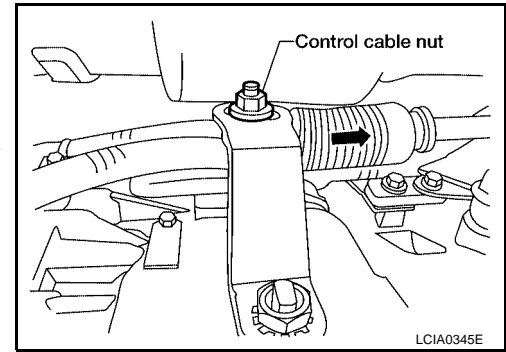

3. CHECK STARTING SYSTEM

Check the starting system. Refer to [SC-10, "STARTING SYSTEM"](#) .

OK or NG

OK >> Inspection End.

NG >> Repair or replace damaged parts.

In "P" Position, Vehicle Moves When Pushed SYMPTOM:

ECS00B2I

Even though the selector lever is set in the "P" position, the parking mechanism is not actuated, allowing the vehicle to be moved when it is pushed.

DIAGNOSTIC PROCEDURE

1. CHECK PNP SWITCH CIRCUIT

Perform self-diagnosis. Refer to [AT-87, "SELF-DIAGNOSTIC RESULT MODE"](#) .

Do the self-diagnosis results indicate PNP switch?

YES >> Check the malfunctioning system. Refer to [AT-105, "DTC P0705 PARK/NEUTRAL POSITION SWITCH"](#) .

NO >> GO TO 2.

2. CHECK CONTROL CABLE

Check the control cable.

- Refer to [AT-238, "Checking of A/T Position"](#) .

OK or NG

OK >> GO TO 3.

NG >> Adjust control cable. Refer to [AT-238, "Adjustment of A/T Position"](#) .

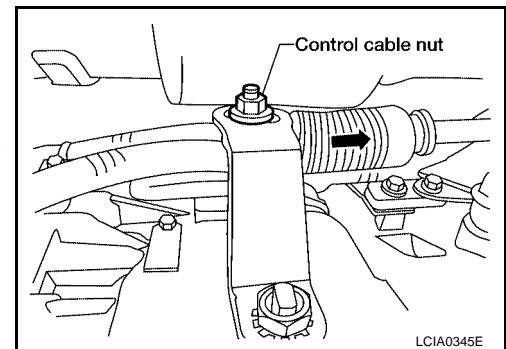

3. CHECK PARKING COMPONENTS

Check parking components. Refer to [AT-283, "DISASSEMBLY"](#) .

OK or NG

OK >> GO TO 4

NG >> Repair or replace damaged parts.

TROUBLE DIAGNOSIS FOR SYMPTOMS

4. CHECK A/T FLUID CONDITION

1. Remove oil pan. Refer to [AT-250, "Control Valve With TCM and A/T Fluid Temperature Sensor 2"](#) .
2. Check A/T fluid condition. Refer to [AT-52, "Fluid Condition Check"](#) .

OK or NG

OK >> **INSPECTION END**

NG >> Check the malfunction items. If any items are damaged, repair or replace damaged parts. Refer to [AT-63, "Symptom Chart"](#) (Symptom No.58)

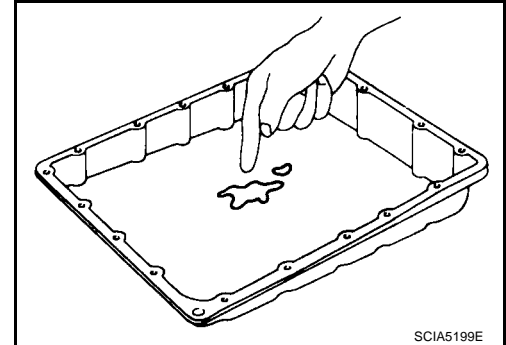

SCIA5199E

In "N" Position, Vehicle Moves SYMPTOM:

Vehicle moves forward or backward when selecting "N" position.

DIAGNOSTIC PROCEDURE

1. CHECK PNP SWITCH CIRCUIT

Perform self-diagnosis. Refer to [AT-87, "SELF-DIAGNOSTIC RESULT MODE"](#) .

Do the self-diagnostic results indicate PNP switch?

- YES >> Check the malfunctioning system. Refer to [AT-105, "DTC P0705 PARK/NEUTRAL POSITION SWITCH"](#) .
- NO >> GO TO 2.

2. CHECK CONTROL CABLE

Check the control cable.

- Refer to [AT-238, "Checking of A/T Position"](#) .

OK or NG

OK >> GO TO 3.

NG >> Adjust control cable. Refer to [AT-238, "Adjustment of A/T Position"](#) .

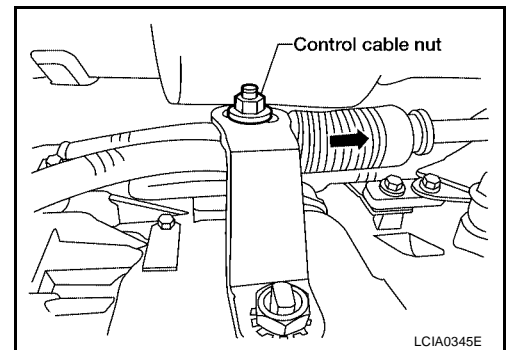

LCIA0345E

3. CHECK A/T FLUID LEVEL

Check A/T fluid level. Refer to [AT-12, "Checking A/T Fluid"](#) .

OK or NG

OK >> GO TO 4.

NG >> Refill ATF.

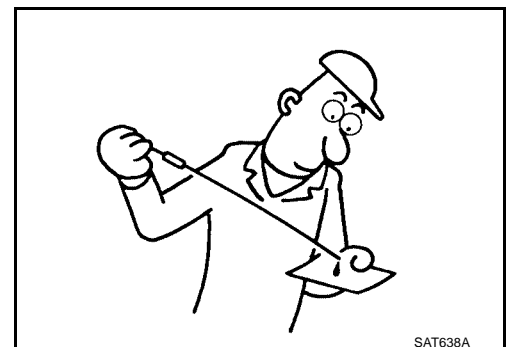

SAT638A

TROUBLE DIAGNOSIS FOR SYMPTOMS

4. CHECK A/T FLUID CONDITION

1. Remove oil pan. Refer to [AT-250, "Control Valve With TCM and A/T Fluid Temperature Sensor 2"](#) .
2. Check A/T fluid condition. Refer to [AT-52, "Fluid Condition Check"](#) .

OK or NG

- OK >> GO TO 5.
NG >> Check the malfunction items. If any items are damaged, repair or replace damaged parts. Refer to [AT-63, "Symptom Chart"](#) (Symptom No.67).

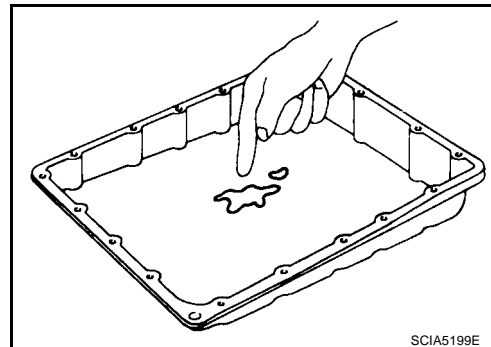

5. CHECK SYMPTOM

Check again. Refer to [AT-56, "Check at Idle"](#) .

OK or NG

- OK >> **INSPECTION END**
NG >> GO TO 6.

6. PERFORM TCM INSPECTION

1. Perform TCM input/output signals inspection. Refer to [AT-84, "TCM Input/Output Signal Reference Values"](#) .
2. If NG, recheck A/T assembly harness connector terminals for damage or loose connection with harness connector.

OK or NG

- OK >> **INSPECTION END**
NG >> Repair or replace damaged parts.

Large Shock ("N" to "D" Position)

ECS00B2K

SYMPTOM:

A noticeable shock occurs when the selector lever is shifted from the "N" to "D" position.

DIAGNOSTIC PROCEDURE

1. CHECK SELF-DIAGNOSTIC RESULTS

Perform self-diagnosis. Refer to [AT-87, "SELF-DIAGNOSTIC RESULT MODE"](#) .

Do the self-diagnostic results indicate A/T fluid temperature sensor, engine speed signal, accelerator pedal position sensor, ATF pressure switch 1, front brake solenoid valve, CAN communication line?

- YES >> Check the malfunctioning system. Refer to [AT-127, "DTC P1710 A/T FLUID TEMPERATURE SENSOR CIRCUIT"](#) , [AT-114, "DTC P0725 ENGINE SPEED SIGNAL"](#) , [AT-124, "DTC P1705 THROTTLE POSITION SENSOR"](#) , [AT-166, "DTC P1841 ATF PRESSURE SWITCH 1"](#) , [AT-145, "DTC P1757 FRONT BRAKE SOLENOID VALVE"](#) , [AT-97, "DTC U1000 CAN COMMUNICATION LINE"](#) .
- NO >> GO TO 2.

2. ENGINE IDLE SPEED

Check the engine idle speed. Refer to [EC-76, "Idle Speed and Ignition Timing Check"](#) .

OK or NG

- OK >> GO TO 3.
NG >> Repair.

TROUBLE DIAGNOSIS FOR SYMPTOMS

3. CHECK CONTROL CABLE

Check the control cable.

- Refer to [AT-238, "Checking of A/T Position"](#) .

OK or NG

OK >> GO TO 4.

NG >> Adjust control cable. Refer to [AT-238, "Adjustment of A/T Position"](#) .

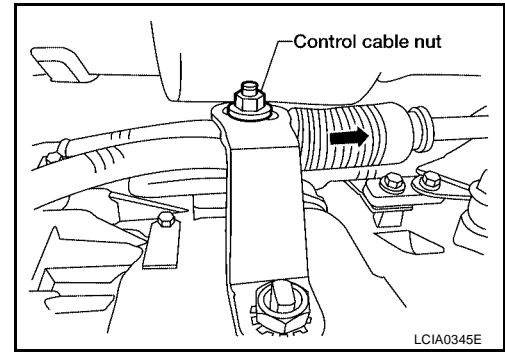

4. CHECK A/T FLUID LEVEL

Check the A/T fluid level. Refer to [AT-12, "Checking A/T Fluid"](#) .

OK or NG

OK >> GO TO 5.

NG >> Refill ATF.

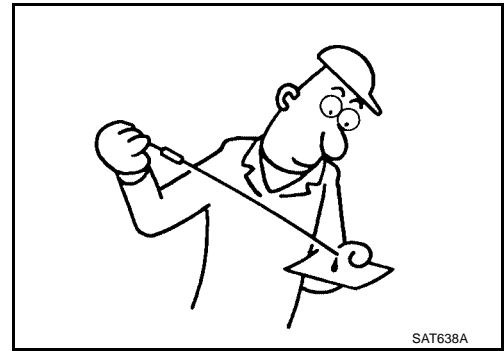

5. CHECK LINE PRESSURE

Check line pressure at idle with selector lever in "D" position. Refer to [AT-53, "LINE PRESSURE TEST"](#) .

OK or NG

OK >> GO TO 8.

NG - 1 >> Line pressure high: GO TO 6.

NG - 2 >> Line pressure low: GO TO 7.

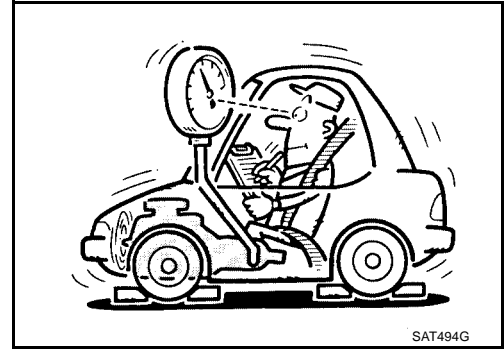

6. DETECT MALFUNCTIONING ITEM

1. Control valve with TCM. Refer to [AT-250, "CONTROL VALVE WITH TCM REMOVAL AND INSTALLATION"](#) .

2. Disassemble A/T. Refer to [AT-283, "DISASSEMBLY"](#) .

3. Check the following items:

- Oil pump assembly. Refer to [AT-300, "Oil Pump"](#) .

OK or NG

OK >> GO TO 8.

NG >> Repair or replace damaged parts.

TROUBLE DIAGNOSIS FOR SYMPTOMS

7. DETECT MALFUNCTIONING ITEM

1. Control valve with TCM. Refer to [AT-250, "CONTROL VALVE WITH TCM REMOVAL AND INSTALLATION"](#).
2. Disassemble A/T. Refer to [AT-283, "DISASSEMBLY"](#).
3. Check the following items:
 - Oil pump assembly. Refer to [AT-300, "Oil Pump"](#).
 - Power train system. Refer to [AT-283, "DISASSEMBLY"](#).
 - Transmission case. Refer to [AT-283, "DISASSEMBLY"](#).

OK or NG

- OK >> GO TO 8.
NG >> Repair or replace damaged parts.

8. CHECK A/T FLUID CONDITION

1. Remove oil pan. Refer to [AT-250, "Control Valve With TCM and A/T Fluid Temperature Sensor 2"](#).
2. Check A/T fluid condition. Refer to [AT-52, "Fluid Condition Check"](#).

OK or NG

- OK >> GO TO 10.
NG >> GO TO 9.

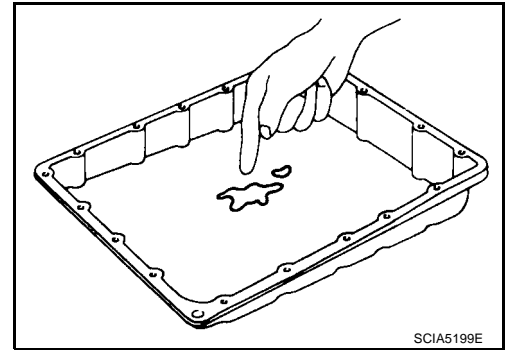

9. DETECT MALFUNCTIONING ITEM

- Check the malfunction items. If any items are damaged, repair or replace damaged parts. Refer to [AT-63, "Symptom Chart"](#) (Symptom No.1).

OK or NG

- OK >> GO TO 10.
NG >> Repair or replace damaged parts.

10. CHECK SYMPTOM

Check again. Refer to [AT-56, "Check at Idle"](#).

OK or NG

- OK >> **INSPECTION END**
NG >> GO TO 11.

11. PERFORM TCM INSPECTION

1. Perform TCM input/output signals inspection. Refer to [AT-84, "TCM Input/Output Signal Reference Values"](#).
2. If NG, recheck A/T assembly harness connector terminals for damage or loose connection with harness connector.

OK or NG

- OK >> **INSPECTION END**
NG >> Repair or replace damaged parts.

TROUBLE DIAGNOSIS FOR SYMPTOMS

ECS00B2L

Vehicle Does Not Creep Backward In “R” Position

SYMPTOM:

The vehicle does not creep in the “R” position. Or an extreme lack of acceleration is observed.

DIAGNOSTIC PROCEDURE

1. CHECK SELF-DIAGNOSTIC RESULTS

Perform self-diagnosis. Refer to [AT-87, "SELF-DIAGNOSTIC RESULT MODE"](#) .

Do the self-diagnostic results indicate accelerator pedal position sensor, ATF pressure switch 6, high and low reverse clutch solenoid valve, CAN communication line, PNP switch?

YES >> Check the malfunctioning system. Refer to [AT-124, "DTC P1705 THROTTLE POSITION SENSOR"](#) , [AT-172, "DTC P1846 ATF PRESSURE SWITCH 6"](#) , [AT-153, "DTC P1767 HIGH AND LOW REVERSE CLUTCH SOLENOID VALVE"](#) , [AT-97, "DTC U1000 CAN COMMUNICATION LINE"](#) , [AT-105, "DTC P0705 PARK/NEUTRAL POSITION SWITCH"](#) .

NO >> GO TO 2.

2. CHECK CONTROL CABLE

Check the control cable.

- Refer to [AT-238, "Checking of A/T Position"](#) .

OK or NG

OK >> GO TO 3.

NG >> Adjust control cable. Refer to [AT-238, "Adjustment of A/T Position"](#) .

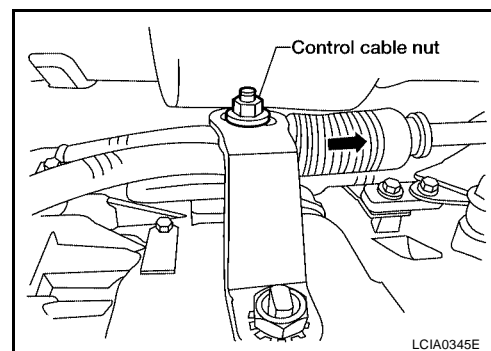

3. CHECK A/T FLUID LEVEL

Check A/T fluid level. Refer to [AT-12, "Checking A/T Fluid"](#) .

OK or NG

OK >> GO TO 4.

NG >> Refill ATF.

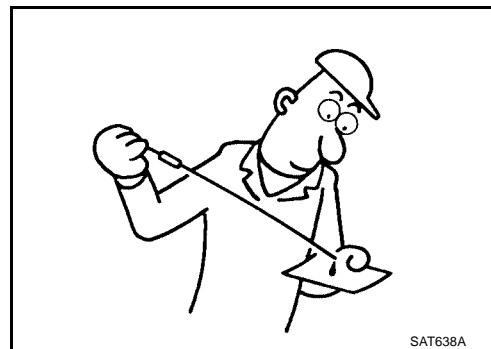

4. CHECK STALL TEST

Check stall revolution with selector lever in “1” and “R” positions.

Refer to [AT-52, "STALL TEST"](#) .

OK or NG

OK >> GO TO 6.

OK in “M” position, NG in “R” position>>GO TO 5.

NG in both “M” and “R” positions>>GO TO 8.

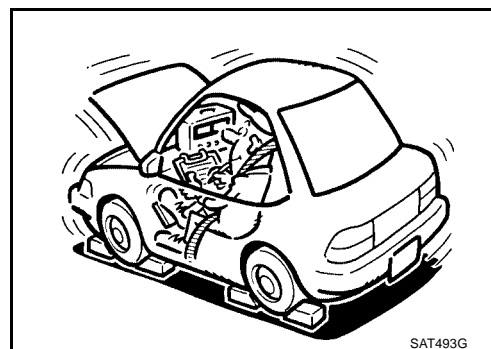

TROUBLE DIAGNOSIS FOR SYMPTOMS

5. DETECT MALFUNCTIONING ITEM

1. Disassemble A/T. Refer to [AT-283, "DISASSEMBLY"](#) .
2. Check the following items:
 - Reverse brake. Refer to [AT-283, "DISASSEMBLY"](#) .

OK or NG

- OK >> GO TO 9.
- NG >> Repair or replace damaged parts.

6. CHECK LINE PRESSURE

Check the line pressure with the engine idling. Refer to [AT-53, "LINE PRESSURE TEST"](#) .

OK or NG

- OK >> GO TO 9.
- NG - 1 >> Line pressure high. GO TO 7.
- NG - 2 >> Line pressure low. GO TO 8.

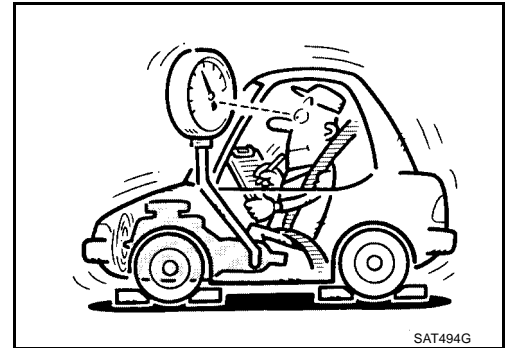

7. DETECT MALFUNCTIONING ITEM

1. Control valve with TCM. Refer to [AT-250, "CONTROL VALVE WITH TCM REMOVAL AND INSTALLATION"](#) .
2. Disassemble A/T. Refer to [AT-283, "DISASSEMBLY"](#) .
3. Check the following items:
 - Oil pump assembly. Refer to [AT-300, "Oil Pump"](#) .

OK or NG

- OK >> GO TO 9.
- NG >> Repair or replace damaged parts.

8. DETECT MALFUNCTIONING ITEM

1. Control valve with TCM. Refer to [AT-250, "CONTROL VALVE WITH TCM REMOVAL AND INSTALLATION"](#) .
2. Disassemble A/T. Refer to [AT-283, "DISASSEMBLY"](#) .
3. Check the following items:
 - Oil pump assembly. Refer to [AT-300, "Oil Pump"](#) .
 - Power train system. Refer to [AT-283, "DISASSEMBLY"](#) .
 - Transmission case. Refer to [AT-283, "DISASSEMBLY"](#) .

OK or NG

- OK >> GO TO 9.
- NG >> Repair or replace damaged parts.

TROUBLE DIAGNOSIS FOR SYMPTOMS

9. CHECK A/T FLUID CONDITION

1. Remove oil pan. Refer to [AT-250, "Control Valve With TCM and A/T Fluid Temperature Sensor 2"](#) .
2. Check A/T fluid condition. Refer to [AT-52, "Fluid Condition Check"](#) .

OK or NG

- OK >> GO TO 10.
- NG >> GO TO 13.

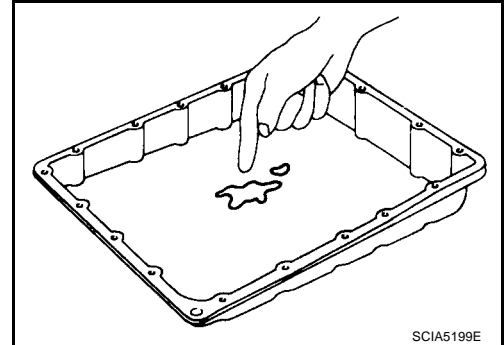

SCIA5199E

10. DETECT MALFUNCTIONING ITEM

- Check the malfunction items. If any items are damaged, repair or replace damaged parts. Refer to [AT-63, "Symptom Chart"](#) (Symptom No.43).

OK or NG

- OK >> GO TO 11.
- NG >> Repair or replace damaged parts.

11. CHECK SYMPTOM

Check again. Refer to [AT-56, "Check at Idle"](#) .

OK or NG

- OK >> **INSPECTION END**
- NG >> GO TO 12.

12. PERFORM TCM INSPECTION

1. Perform TCM input/output signals inspection. Refer to [AT-84, "TCM Input/Output Signal Reference Values"](#) .
2. If NG, recheck A/T assembly harness connector terminals for damage or loose connection with harness connector.

OK or NG

- OK >> **INSPECTION END**
- NG >> Repair or replace damaged parts.

13. DETECT MALFUNCTIONING ITEM

- Check the malfunction items. If any items are damaged, repair or replace damaged parts. Refer to [AT-63, "Symptom Chart"](#) (Symptom No.43).

OK or NG

- OK >> GO TO 11.
- NG >> Repair or replace damaged parts.

TROUBLE DIAGNOSIS FOR SYMPTOMS

ECS00B2M

Vehicle Does Not Creep Forward In "D" Position

SYMPTOM:

Vehicle does not creep forward when selecting "D" position.

DIAGNOSTIC PROCEDURE

1. CHECK SELF-DIAGNOSTIC RESULTS

Perform self-diagnosis. Refer to [AT-87, "SELF-DIAGNOSTIC RESULT MODE"](#) .

Do the self-diagnostic results indicate accelerator pedal position sensor, CAN communication line, PNP switch?

YES >> Check the malfunctioning system. Refer to [AT-124, "DTC P1705 THROTTLE POSITION SENSOR"](#) , [AT-97, "DTC U1000 CAN COMMUNICATION LINE"](#) , [AT-105, "DTC P0705 PARK/NEUTRAL POSITION SWITCH"](#) .

NO >> GO TO 2.

2. CHECK CONTROL CABLE

Check the control cable.

- Refer to [AT-238, "Checking of A/T Position"](#) .

OK or NG

OK >> GO TO 3.

NG >> Adjust control cable. Refer to [AT-238, "Adjustment of A/T Position"](#) .

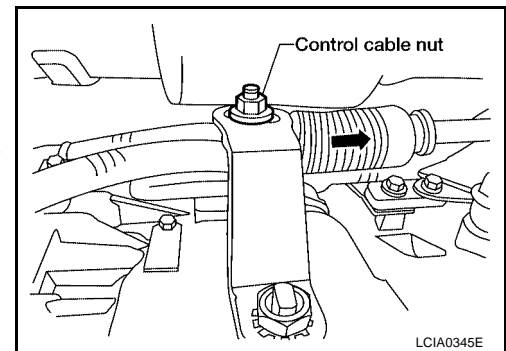

3. CHECK A/T FLUID LEVEL

Check A/T fluid level. Refer to [AT-12, "Checking A/T Fluid"](#) .

OK or NG

OK >> GO TO 4.

NG >> Refill ATF.

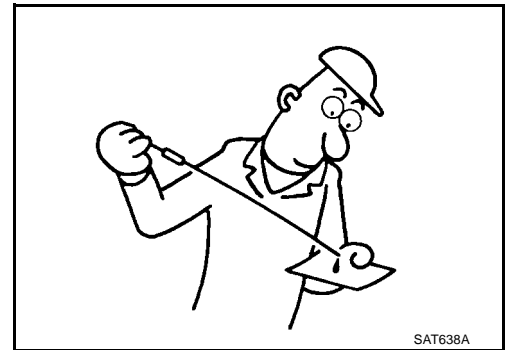

4. CHECK STALL TEST

Check stall revolution with selector lever in "D" position. Refer to [AT-52, "STALL TEST"](#) .

OK or NG

OK >> GO TO 5.

NG >> GO TO 7.

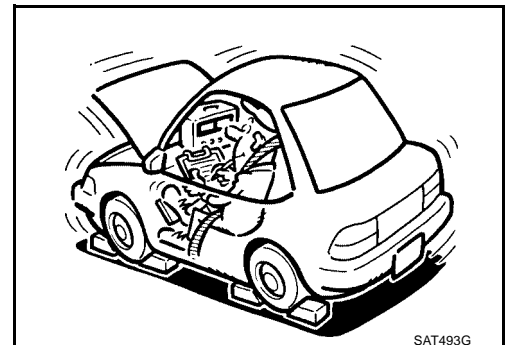

TROUBLE DIAGNOSIS FOR SYMPTOMS

5. CHECK LINE PRESSURE

Check line pressure at idle with selector lever in "D" position. Refer to [AT-53, "LINE PRESSURE TEST"](#) .

OK or NG

- OK >> GO TO 8.
- NG - 1 >> Line pressure high. GO TO 6.
- NG - 2 >> Line pressure low. GO TO 7.

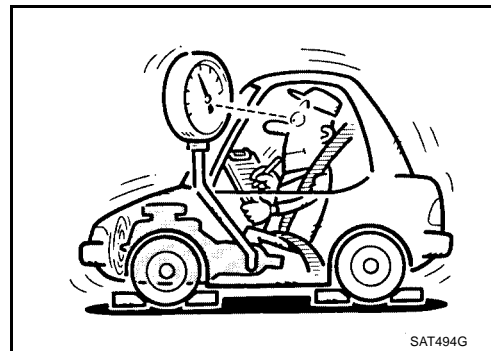

SAT494G

6. DETECT MALFUNCTIONING ITEM

1. Control valve with TCM. Refer to [AT-250, "CONTROL VALVE WITH TCM REMOVAL AND INSTALLATION"](#) .
2. Disassemble A/T. Refer to [AT-283, "DISASSEMBLY"](#) .
3. Check the following items:
 - Oil pump assembly. Refer to [AT-300, "Oil Pump"](#) .

OK or NG

- OK >> GO TO 8.
- NG >> Repair or replace damaged parts.

7. DETECT MALFUNCTIONING ITEM

1. Control valve with TCM. Refer to [AT-250, "CONTROL VALVE WITH TCM REMOVAL AND INSTALLATION"](#) .
2. Disassemble A/T. Refer to [AT-283, "DISASSEMBLY"](#) .
3. Check the following items:
 - Oil pump assembly. Refer to [AT-300, "Oil Pump"](#) .
 - Power train system. Refer to [AT-283, "DISASSEMBLY"](#) .
 - Transmission case. Refer to [AT-283, "DISASSEMBLY"](#) .

OK or NG

- OK >> GO TO 8.
- NG >> Repair or replace damaged parts.

8. CHECK A/T FLUID CONDITION

1. Remove oil pan. Refer to [AT-250, "Control Valve With TCM and A/T Fluid Temperature Sensor 2"](#) .
2. Check A/T fluid condition. Refer to [AT-52, "Fluid Condition Check"](#) .

OK or NG

- OK >> GO TO 9.
- NG >> GO TO 12.

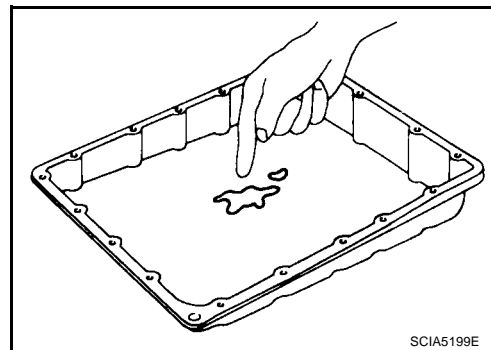

SCIA5199E

TROUBLE DIAGNOSIS FOR SYMPTOMS

9. DETECT MALFUNCTIONING ITEM

- Check the malfunction items. If any items are damaged, repair or replace damaged parts. Refer to [AT-63, "Symptom Chart"](#) (Symptom No.43).

OK or NG

- OK >> GO TO 10.
- NG >> Repair or replace damaged parts.

10. CHECK SYMPTOM

Check again. Refer to [AT-56, "Check at Idle"](#) .

OK or NG

- OK >> **INSPECTION END**
- NG >> GO TO 11.

11. PERFORM TCM INSPECTION

1. Perform TCM input/output signals inspection. Refer to [AT-84, "TCM Input/Output Signal Reference Values"](#) .
2. If NG, recheck A/T assembly harness connector terminals for damage or loose connection with harness connector.

OK or NG

- OK >> **INSPECTION END**
- NG >> Repair or replace damaged parts.

12. DETECT MALFUNCTIONING ITEM

- Check the malfunction items. If any items are damaged, repair or replace damaged parts. Refer to [AT-63, "Symptom Chart"](#) (Symptom No.43).

OK or NG

- OK >> GO TO 10.
- NG >> Repair or replace damaged parts.

Vehicle Cannot Be Started From D1 SYMPTOM:

ECS00B2N

Vehicle cannot be started from D1 on cruise test - Part 1.

DIAGNOSTIC PROCEDURE

1. CONFIRM THE SYMPTOM

Check if vehicle creeps in "R" position.

OK or NG

- OK >> GO TO 2.
- NG >> Refer to [AT-192, "Vehicle Does Not Creep Backward In "R" Position"](#) .

2. CHECK SELF-DIAGNOSTIC RESULTS

Perform self-diagnosis. Refer to [AT-87, "SELF-DIAGNOSTIC RESULT MODE"](#) .

Is any malfunction detected by self-diagnostic results?

- YES >> Check the malfunctioning system.
- NO >> GO TO 3.

TROUBLE DIAGNOSIS FOR SYMPTOMS

3. CHECK ACCELERATOR POSITION (APP) SENSOR

Check accelerator pedal position (APP) sensor. Refer to [AT-124, "DTC P1705 THROTTLE POSITION SENSOR"](#)

OK or NG

OK >> GO TO 4.

NG >> Repair or replace accelerator pedal position (APP) sensor.

4. CHECK A/T FLUID LEVEL

Check A/T fluid level. Refer to [AT-12, "Checking A/T Fluid"](#) .

OK or NG

OK >> GO TO 5.

NG >> Refill ATF.

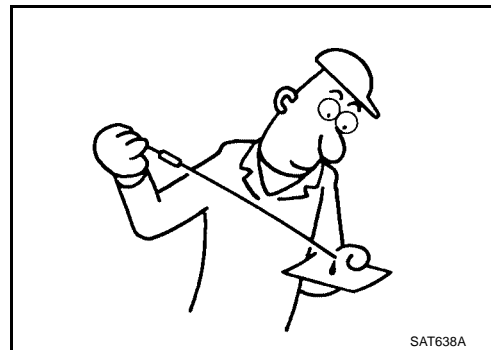

5. CHECK LINE PRESSURE

Check line pressure at the engine stall point. Refer to [AT-53, "LINE PRESSURE TEST"](#) .

OK or NG

OK >> GO TO 8.

NG - 1 >> Line pressure high. GO TO 6.

NG - 2 >> Line pressure low. GO TO 7.

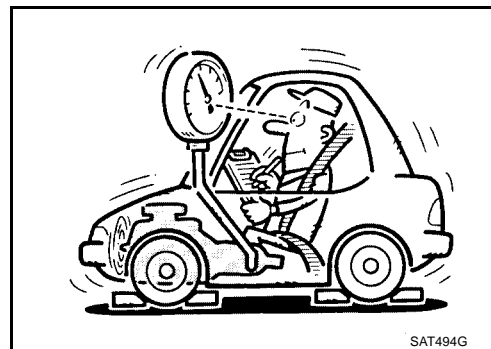

6. DETECT MALFUNCTIONING ITEM

1. Control valve with TCM. Refer to [AT-250, "CONTROL VALVE WITH TCM REMOVAL AND INSTALLATION"](#) .

2. Disassemble A/T. Refer to [AT-283, "DISASSEMBLY"](#) .

3. Check the following items:

- Oil pump assembly. Refer to [AT-300, "Oil Pump"](#) .

OK or NG

OK >> GO TO 8.

NG >> Repair or replace damaged parts.

TROUBLE DIAGNOSIS FOR SYMPTOMS

7. DETECT MALFUNCTIONING ITEM

1. Control valve with TCM. Refer to [AT-250, "CONTROL VALVE WITH TCM REMOVAL AND INSTALLATION"](#) .
2. Disassemble A/T. Refer to [AT-283, "DISASSEMBLY"](#) .
3. Check the following items:
 - Oil pump assembly. Refer to [AT-300, "Oil Pump"](#) .
 - Power train system. Refer to [AT-283, "DISASSEMBLY"](#) .
 - Transmission case. Refer to [AT-283, "DISASSEMBLY"](#) .

OK or NG

- OK >> GO TO 8.
NG >> Repair or replace damaged parts.

8. CHECK A/T FLUID CONDITION

1. Remove oil pan. Refer to [AT-250, "Control Valve With TCM and A/T Fluid Temperature Sensor 2"](#) .
2. Check A/T fluid condition. Refer to [AT-52, "Fluid Condition Check"](#) .

OK or NG

- OK >> GO TO 9.
NG >> GO TO 12.

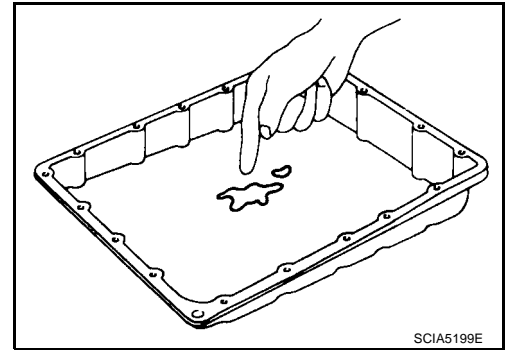

9. DETECT MALFUNCTIONING ITEM

- Check the malfunction items. If any items are damaged, repair or replace damaged parts. Refer to [AT-63, "Symptom Chart"](#) (Symptom No.23).

OK or NG

- OK >> GO TO 10.
NG >> Repair or replace damaged parts.

10. CHECK SYMPTOM

Check again. Refer to [AT-57, "Cruise Test - Part 1"](#) , [AT-59, "Cruise Test - Part 2"](#) .

OK or NG

- OK >> **INSPECTION END**
NG >> GO TO 11.

11. PERFORM TCM INSPECTION

1. Perform TCM input/output signals inspection. Refer to [AT-84, "TCM Input/Output Signal Reference Values"](#) .
2. If NG, recheck A/T assembly harness connector terminals for damage or loose connection with harness connector.

OK or NG

- OK >> **INSPECTION END**
NG >> Repair or replace damaged parts.

TROUBLE DIAGNOSIS FOR SYMPTOMS

12. DETECT MALFUNCTIONING ITEM

- Check the malfunction items. If any items are damaged, repair or replace damaged parts. Refer to [AT-63, "Symptom Chart"](#) (Symptom No.23).

OK or NG

- OK >> GO TO 10.
- NG >> Repair or replace damaged parts.

A/T Does Not Shift: D1 → D2

ECS00B20

SYMPTOM:

The vehicle does not shift-up from the D1 to D2 gear at the specified speed.

DIAGNOSTIC PROCEDURE

1. CONFIRM THE SYMPTOM

Check if vehicle creeps forward in "D" position and vehicle can be started from D1.

OK or NG

- OK >> GO TO 2.
- NG >> Refer to [AT-195, "Vehicle Does Not Creep Forward In "D" Position"](#) , [AT-197, "Vehicle Cannot Be Started From D1"](#) .

2. CHECK SELF-DIAGNOSTIC RESULTS

Perform self-diagnosis. Refer to [AT-87, "SELF-DIAGNOSTIC RESULT MODE"](#) .

Do the self-diagnostic results indicate ATF pressure switch 5, direct clutch solenoid valve, accelerator pedal position sensor, vehicle speed sensor A/T (revolution sensor) and vehicle speed sensor MTR?

- YES >> Check the malfunctioning system. Refer to [AT-170, "DTC P1845 ATF PRESSURE SWITCH 5"](#) , [AT-149, "DTC P1762 DIRECT CLUTCH SOLENOID VALVE"](#) , [AT-124, "DTC P1705 THROTTLE POSITION SENSOR"](#) , [AT-109, "DTC P0720 VEHICLE SPEED SENSOR A/T \(REVOLUTION SENSOR\)"](#) , [AT-134, "DTC P1721 VEHICLE SPEED SENSOR MTR"](#) .
- NO >> GO TO 3.

3. CHECK A/T FLUID LEVEL

Check A/T fluid level. Refer to [AT-12, "Checking A/T Fluid"](#) .

OK or NG

- OK >> GO TO 4.
- NG >> Refill ATF.

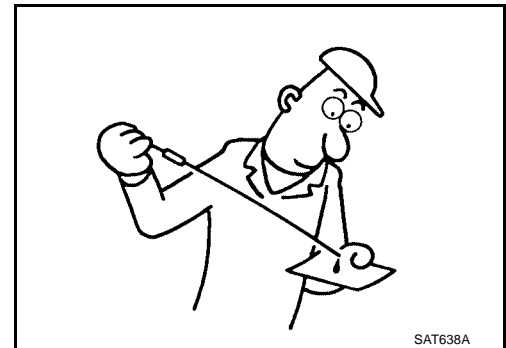

4. CHECK LINE PRESSURE

Check line pressure at the engine stall point. Refer to [AT-53, "LINE PRESSURE TEST"](#) .

OK or NG

- OK >> GO TO 7.
- NG - 1 >> Line pressure high. GO TO 5.
- NG - 2 >> Line pressure low. GO TO 6.

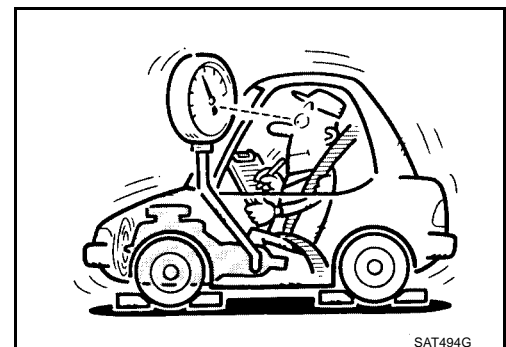

TROUBLE DIAGNOSIS FOR SYMPTOMS

5. DETECT MALFUNCTIONING ITEM

1. Control valve with TCM. Refer to [AT-250, "CONTROL VALVE WITH TCM REMOVAL AND INSTALLATION"](#) .
2. Disassemble A/T. Refer to [AT-283, "DISASSEMBLY"](#) .
3. Check the following items:
 - Oil pump assembly. Refer to [AT-300, "Oil Pump"](#) .

OK or NG

- OK >> GO TO 7.
- NG >> Repair or replace damaged parts.

6. DETECT MALFUNCTIONING ITEM

1. Control valve with TCM. Refer to [AT-250, "CONTROL VALVE WITH TCM REMOVAL AND INSTALLATION"](#) .
2. Disassemble A/T. Refer to [AT-283, "DISASSEMBLY"](#) .
3. Check the following items:
 - Oil pump assembly. Refer to [AT-300, "Oil Pump"](#) .
 - Power train system. Refer to [AT-283, "DISASSEMBLY"](#) .
 - Transmission case. Refer to [AT-283, "DISASSEMBLY"](#) .

OK or NG

- OK >> GO TO 7.
- NG >> Repair or replace damaged parts.

7. CHECK A/T FLUID CONDITION

1. Remove oil pan. Refer to [AT-250, "Control Valve With TCM and A/T Fluid Temperature Sensor 2"](#) .
2. Check A/T fluid condition. Refer to [AT-52, "Fluid Condition Check"](#) .

OK or NG

- OK >> GO TO 8.
- NG >> GO TO 11.

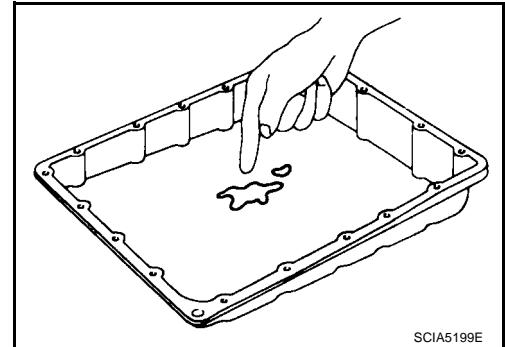

8. DETECT MALFUNCTIONING ITEM

- Check the malfunction items. If any items are damaged, repair or replace damaged parts. Refer to [AT-63, "Symptom Chart"](#) (Symptom No.10).

OK or NG

- OK >> GO TO 9.
- NG >> Repair or replace damaged parts.

9. CHECK SYMPTOM

Check again. Refer to [AT-57, "Cruise Test - Part 1"](#) , [AT-59, "Cruise Test - Part 2"](#) .

OK or NG

- OK >> **INSPECTION END**
- NG >> GO TO 10.

TROUBLE DIAGNOSIS FOR SYMPTOMS

10. PERFORM TCM INSPECTION

1. Perform TCM input/output signals inspection. Refer to [AT-84, "TCM Input/Output Signal Reference Values"](#) .
2. If NG, recheck A/T assembly harness connector terminals for damage or loose connection with harness connector.

OK or NG

- OK >> **INSPECTION END**
NG >> Repair or replace damaged parts.

11. DETECT MALFUNCTIONING ITEM

- Check the malfunction items. If any items are damaged, repair or replace damaged parts. Refer to [AT-63, "Symptom Chart"](#) (Symptom No.10).

OK or NG

- OK >> GO TO 9.
NG >> Repair or replace damaged parts.

A/T Does Not Shift: D2 → D3 SYMPTOM:

ECS00B2P

The vehicle does not shift-up from D2 to D3 gear at the specified speed.

DIAGNOSTIC PROCEDURE

1. CONFIRM THE SYMPTOM

Check if vehicle creeps forward in "D" position" and vehicle can be started from D1.

OK or NG

- OK >> GO TO 2.
NG >> Refer to [AT-195, "Vehicle Does Not Creep Forward In "D" Position"](#) , [AT-197, "Vehicle Cannot Be Started From D1"](#) .

2. CHECK SELF-DIAGNOSTIC RESULTS

Perform self-diagnosis. Refer to [AT-87, "SELF-DIAGNOSTIC RESULT MODE"](#) .

Do the self-diagnostic results indicate ATF pressure switch 6, high and low reverse clutch solenoid valve, accelerator pedal position sensor, vehicle speed sensor A/T (revolution sensor) and vehicle speed sensor MTR?

- YES >> Check the malfunctioning system. Refer to [AT-172, "DTC P1846 ATF PRESSURE SWITCH 6"](#) , [AT-153, "DTC P1767 HIGH AND LOW REVERSE CLUTCH SOLENOID VALVE"](#) , [AT-124, "DTC P1705 THROTTLE POSITION SENSOR"](#) , [AT-109, "DTC P0720 VEHICLE SPEED SENSOR A/T \(REVOLUTION SENSOR\)"](#) , [AT-134, "DTC P1721 VEHICLE SPEED SENSOR MTR"](#) .
- NO >> GO TO 3.

3. CHECK A/T FLUID LEVEL

Check A/T fluid level. Refer to [AT-12, "Checking A/T Fluid"](#) .

OK or NG

- OK >> GO TO 4.
NG >> Refill ATF.

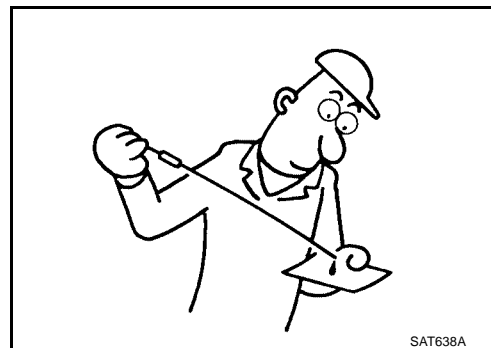

SAT638A

TROUBLE DIAGNOSIS FOR SYMPTOMS

4. CHECK LINE PRESSURE

Check line pressure at the engine stall point. Refer to [AT-53, "LINE PRESSURE TEST"](#) .

OK or NG

- OK >> GO TO 7.
- NG - 1 >> Line pressure high. GO TO 5.
- NG - 2 >> Line pressure low. GO TO 6.

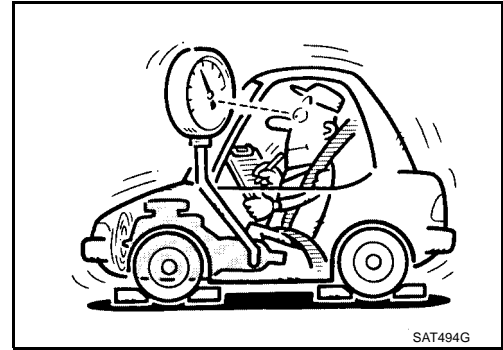

5. DETECT MALFUNCTIONING ITEM

1. Control valve with TCM. Refer to [AT-250, "CONTROL VALVE WITH TCM REMOVAL AND INSTALLATION"](#) .
2. Disassemble A/T. Refer to [AT-283, "DISASSEMBLY"](#) .
3. Check the following items:
 - Oil pump assembly. Refer to [AT-300, "Oil Pump"](#) .

OK or NG

- OK >> GO TO 7.
- NG >> Repair or replace damaged parts.

6. DETECT MALFUNCTIONING ITEM

1. Control valve with TCM. Refer to [AT-250, "CONTROL VALVE WITH TCM REMOVAL AND INSTALLATION"](#) .
2. Disassemble A/T. Refer to [AT-283, "DISASSEMBLY"](#) .
3. Check the following items:
 - Oil pump assembly. Refer to [AT-300, "Oil Pump"](#) .
 - Power train system. Refer to [AT-283, "DISASSEMBLY"](#) .
 - Transmission case. Refer to [AT-283, "DISASSEMBLY"](#) .

OK or NG

- OK >> GO TO 7.
- NG >> Repair or replace damaged parts.

7. CHECK A/T FLUID CONDITION

1. Remove oil pan. Refer to [AT-250, "Control Valve With TCM and A/T Fluid Temperature Sensor 2"](#) .
2. Check A/T fluid condition. Refer to [AT-52, "Fluid Condition Check"](#) .

OK or NG

- OK >> GO TO 8.
- NG >> GO TO 11.

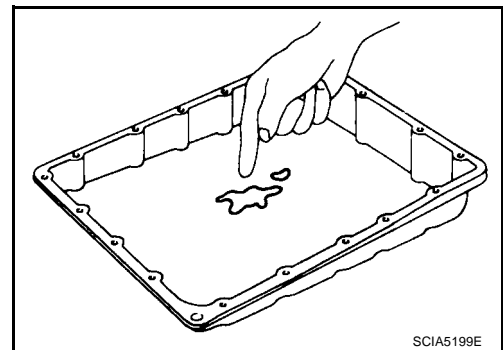

TROUBLE DIAGNOSIS FOR SYMPTOMS

8. DETECT MALFUNCTIONING ITEM

- Check the malfunction items. If any items are damaged, repair or replace damaged parts. Refer to [AT-63, "Symptom Chart"](#) (Symptom No.11).

OK or NG

- OK >> GO TO 9.
- NG >> Repair or replace damaged parts.

9. CHECK SYMPTOM

Check again. Refer to [AT-57, "Cruise Test - Part 1"](#) , [AT-59, "Cruise Test - Part 2"](#) .

OK or NG

- OK >> **INSPECTION END**
- NG >> GO TO 10.

10. PERFORM TCM INSPECTION

1. Perform TCM input/output signals inspection. Refer to [AT-84, "TCM Input/Output Signal Reference Values"](#) .
2. If NG, recheck A/T assembly harness connector terminals for damage or loose connection with harness connector.

OK or NG

- OK >> **INSPECTION END**
- NG >> Repair or replace damaged parts.

11. DETECT MALFUNCTIONING ITEM

- Check the malfunction items. If any items are damaged, repair or replace damaged parts. Refer to [AT-63, "Symptom Chart"](#) (Symptom No.11).

OK or NG

- OK >> GO TO 9.
- NG >> Repair or replace damaged parts.

A/T Does Not Shift: D3 → D4 **SYMPTOM:**

ECS00B2Q

- The vehicle does not shift-up from the D3 to D4 gear at the specified speed.
- The vehicle does not shift-up from the D3 to D4 gear unless A/T is warmed up.

DIAGNOSTIC PROCEDURE

1. CONFIRM THE SYMPTOM

Check if vehicle creeps forward in "D" position" and vehicle can be started from D1.

OK or NG

- OK >> GO TO 2.
- NG >> Refer to [AT-195, "Vehicle Does Not Creep Forward In "D" Position"](#) , [AT-197, "Vehicle Cannot Be Started From D1"](#) .

2. CHECK SELF-DIAGNOSTIC RESULTS

Perform self-diagnosis. Refer to [AT-87, "SELF-DIAGNOSTIC RESULT MODE"](#) .

Do the self-diagnostic results indicate ATF pressure switch 1, ATF pressure switch 3, front brake solenoid valve, input clutch solenoid valve, accelerator pedal position sensor, vehicle speed sensor A/T (revolution sensor) and vehicle speed sensor MTR?

- YES >> Check the malfunctioning system. Refer to [AT-166, "DTC P1841 ATF PRESSURE SWITCH 1"](#) , [AT-168, "DTC P1843 ATF PRESSURE SWITCH 3"](#) , [AT-141, "DTC P1752 INPUT CLUTCH SOLENOID VALVE"](#) , [AT-145, "DTC P1757 FRONT BRAKE SOLENOID VALVE"](#) , [AT-124, "DTC](#)

TROUBLE DIAGNOSIS FOR SYMPTOMS

[P1705 THROTTLE POSITION SENSOR](#) , [AT-109, "DTC P0720 VEHICLE SPEED SENSOR A/T \(REVOLUTION SENSOR\)"](#) , [AT-134, "DTC P1721 VEHICLE SPEED SENSOR MTR"](#) .

NO >> GO TO 3.

3. CHECK A/T FLUID LEVEL

Check A/T fluid level. Refer to [AT-12, "Checking A/T Fluid"](#) .

OK or NG

OK >> GO TO 4.
NG >> Refill ATF.

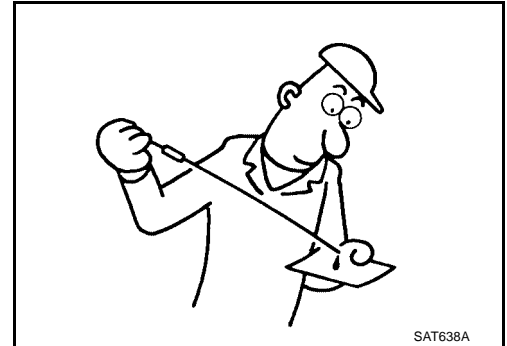

4. CHECK LINE PRESSURE

Check line pressure at the engine stall point. Refer to [AT-53, "LINE PRESSURE TEST"](#) .

OK or NG

OK >> GO TO 7.
NG - 1 >> Line pressure high. GO TO 5.
NG - 2 >> Line pressure low. GO TO 6.

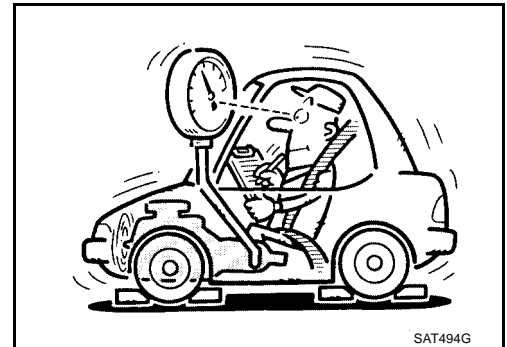

5. DETECT MALFUNCTIONING ITEM

1. Control valve with TCM. Refer to [AT-250, "CONTROL VALVE WITH TCM REMOVAL AND INSTALLATION"](#) .
2. Disassemble A/T. Refer to [AT-283, "DISASSEMBLY"](#) .
3. Check the following items:
 - Oil pump assembly. Refer to [AT-300, "Oil Pump"](#) .

OK or NG

OK >> GO TO 7.
NG >> Repair or replace damaged parts.

6. DETECT MALFUNCTIONING ITEM

1. Control valve with TCM. Refer to [AT-250, "CONTROL VALVE WITH TCM REMOVAL AND INSTALLATION"](#) .
2. Disassemble A/T. Refer to [AT-283, "DISASSEMBLY"](#) .
3. Check the following items:
 - Oil pump assembly. Refer to [AT-300, "Oil Pump"](#) .
 - Power train system. Refer to [AT-283, "DISASSEMBLY"](#) .
 - Transmission case. Refer to [AT-283, "DISASSEMBLY"](#) .

OK or NG

OK >> GO TO 7.
NG >> Repair or replace damaged parts.

A
B
AT
D
E
F
G
H
I
J
K
L
M

TROUBLE DIAGNOSIS FOR SYMPTOMS

7. CHECK A/T FLUID CONDITION

1. Remove oil pan. Refer to [AT-250, "Control Valve With TCM and A/T Fluid Temperature Sensor 2"](#) .
2. Check A/T fluid condition. Refer to [AT-52, "Fluid Condition Check"](#) .

OK or NG

- OK >> GO TO 8.
- NG >> GO TO 11.

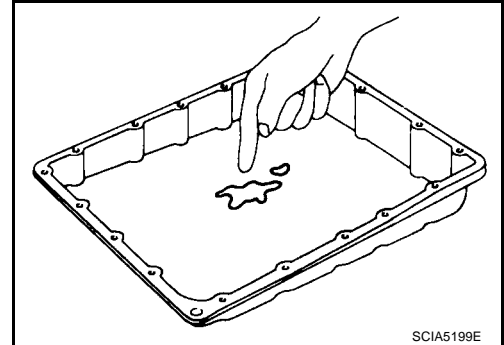

8. DETECT MALFUNCTIONING ITEM

- Check the malfunction items. If any items are damaged, repair or replace damaged parts. Refer to [AT-63, "Symptom Chart"](#) (Symptom No.12).

OK or NG

- OK >> GO TO 9.
- NG >> Repair or replace damaged parts.

9. CHECK SYMPTOM

Check again. Refer to [AT-57, "Cruise Test - Part 1"](#) , [AT-59, "Cruise Test - Part 2"](#) .

OK or NG

- OK >> **INSPECTION END**
- NG >> GO TO 10.

10. PERFORM TCM INSPECTION

1. Perform TCM input/output signals inspection. Refer to [AT-84, "TCM Input/Output Signal Reference Values"](#) .
2. If NG, recheck A/T assembly harness connector terminals for damage or loose connection with harness connector.

OK or NG

- OK >> **INSPECTION END**
- NG >> Repair or replace damaged parts.

11. DETECT MALFUNCTIONING ITEM

- Check the malfunction items. If any items are damaged, repair or replace damaged parts. Refer to [AT-63, "Symptom Chart"](#) (Symptom No.12).

OK or NG

- OK >> GO TO 9.
- NG >> Repair or replace damaged parts.

TROUBLE DIAGNOSIS FOR SYMPTOMS

A/T Does Not Shift: D4 → D5

ECS00B2R

SYMPTOM:

- The vehicle does not shift-up from the D4 to D5 gear at the specified speed.
- The vehicle does not shift-up from the D4 to D5 gear unless A/T is warmed up.

DIAGNOSTIC PROCEDURE

1. CONFIRM THE SYMPTOM

Check if vehicle creeps forward in "D" position and vehicle can be started from D1.

OK or NG

OK >> GO TO 2.

NG >> Refer to [AT-195, "Vehicle Does Not Creep Forward In "D" Position"](#) , [AT-197, "Vehicle Cannot Be Started From D1"](#) .

2. CHECK SELF-DIAGNOSTIC RESULTS

Perform self-diagnosis. Refer to [AT-87, "SELF-DIAGNOSTIC RESULT MODE"](#) .

Do the self-diagnostic results indicate ATF pressure switch 1, ATF pressure switch 5, front brake solenoid valve, direct clutch solenoid valve, accelerator pedal position sensor, turbine revolution sensor, vehicle speed sensor A/T (revolution sensor) and vehicle speed sensor MTR?

YES >> Check the malfunctioning system. Refer to [AT-166, "DTC P1841 ATF PRESSURE SWITCH 1"](#) , [AT-170, "DTC P1845 ATF PRESSURE SWITCH 5"](#) , [AT-145, "DTC P1757 FRONT BRAKE SOLENOID VALVE"](#) , [AT-149, "DTC P1762 DIRECT CLUTCH SOLENOID VALVE"](#) , [AT-124, "DTC P1705 THROTTLE POSITION SENSOR"](#) , [AT-132, "DTC P1716 TURBINE REVOLUTION SENSOR"](#) , [AT-109, "DTC P0720 VEHICLE SPEED SENSOR A/T \(REVOLUTION SENSOR\)"](#) , [AT-134, "DTC P1721 VEHICLE SPEED SENSOR MTR"](#) .

NO >> GO TO 3.

3. CHECK A/T FLUID LEVEL

Check A/T fluid level. Refer to [AT-12, "Checking A/T Fluid"](#) .

OK or NG

OK >> GO TO 4.

NG >> Refill ATF.

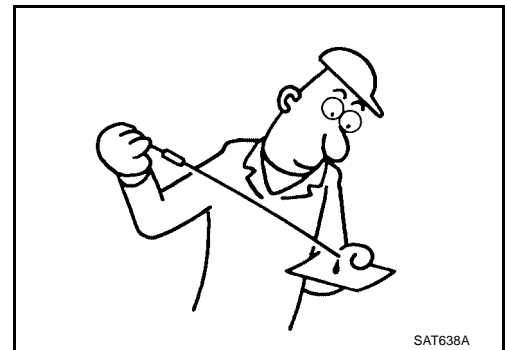

4. CHECK LINE PRESSURE

Check line pressure at the engine stall point. Refer to [AT-53, "LINE PRESSURE TEST"](#) .

OK or NG

OK >> GO TO 7.

NG - 1 >> Line pressure high. GO TO 5.

NG - 2 >> Line pressure low. GO TO 6.

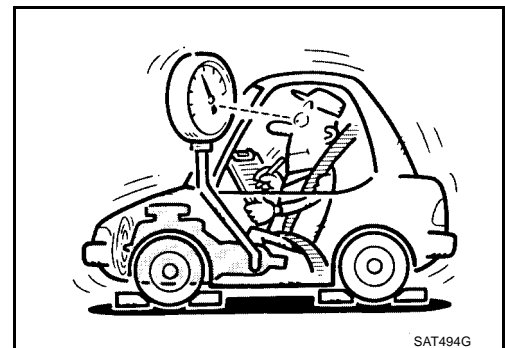

TROUBLE DIAGNOSIS FOR SYMPTOMS

5. DETECT MALFUNCTIONING ITEM

1. Control valve with TCM. Refer to [AT-250, "CONTROL VALVE WITH TCM REMOVAL AND INSTALLATION"](#) .
2. Disassemble A/T. Refer to [AT-283, "DISASSEMBLY"](#) .
3. Check the following items:
 - Oil pump assembly. Refer to [AT-300, "Oil Pump"](#) .

OK or NG

- OK >> GO TO 7.
- NG >> Repair or replace damaged parts.

6. DETECT MALFUNCTIONING ITEM

1. Control valve with TCM. Refer to [AT-250, "CONTROL VALVE WITH TCM REMOVAL AND INSTALLATION"](#) .
2. Disassemble A/T. Refer to [AT-283, "DISASSEMBLY"](#) .
3. Check the following items:
 - Oil pump assembly. Refer to [AT-300, "Oil Pump"](#) .
 - Power train system. Refer to [AT-283, "DISASSEMBLY"](#) .
 - Transmission case. Refer to [AT-283, "DISASSEMBLY"](#) .

OK or NG

- OK >> GO TO 7.
- NG >> Repair or replace damaged parts.

7. CHECK A/T FLUID CONDITION

1. Remove oil pan. Refer to [AT-250, "Control Valve With TCM and A/T Fluid Temperature Sensor 2"](#) .
2. Check A/T fluid condition. Refer to [AT-52, "Fluid Condition Check"](#) .

OK or NG

- OK >> GO TO 8.
- NG >> GO TO 11.

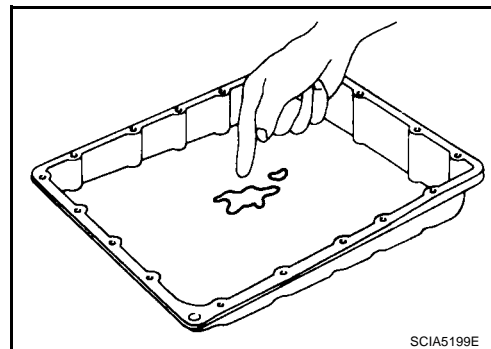

SCIA5199E

8. DETECT MALFUNCTIONING ITEM

- Check the malfunction items. If any items are damaged, repair or replace damaged parts. Refer to [AT-63, "Symptom Chart"](#) (Symptom No.13).

OK or NG

- OK >> GO TO 9.
- NG >> Repair or replace damaged parts.

9. CHECK SYMPTOM

Check again. Refer to [AT-57, "Cruise Test - Part 1"](#) .

OK or NG

- OK >> **INSPECTION END**
- NG >> GO TO 10.

TROUBLE DIAGNOSIS FOR SYMPTOMS

10. PERFORM TCM INSPECTION

1. Perform TCM input/output signals inspection. Refer to [AT-84, "TCM Input/Output Signal Reference Values"](#) .
2. If NG, recheck A/T assembly harness connector terminals for damage or loose connection with harness connector.

OK or NG

- OK >> **INSPECTION END**
NG >> Repair or replace damaged parts.

11. DETECT MALFUNCTIONING ITEM

- Check the malfunction items. If any items are damaged, repair or replace damaged parts. Refer to [AT-63, "Symptom Chart"](#) (Symptom No.13).

OK or NG

- OK >> GO TO 9.
NG >> Repair or replace damaged parts.

A/T Does Not Perform Lock-up SYMPTOM:

ECS00B2S

A/T does not perform lock-up at the specified speed.

DIAGNOSTIC PROCEDURE

1. CHECK SELF-DIAGNOSTIC RESULTS

Perform self-diagnosis. Refer to [AT-87, "SELF-DIAGNOSTIC RESULT MODE"](#) .

Do the self-diagnostic results indicate torque converter clutch solenoid valve, engine speed signal, turbine revolution sensor, accelerator pedal position sensor, CAN communication?

- YES >> Check the malfunctioning system. Refer to [AT-116, "DTC P0740 TORQUE CONVERTER CLUTCH SOLENOID VALVE"](#) , [AT-114, "DTC P0725 ENGINE SPEED SIGNAL"](#) , [AT-132, "DTC P1716 TURBINE REVOLUTION SENSOR"](#) , [AT-124, "DTC P1705 THROTTLE POSITION SENSOR"](#) , [AT-97, "DTC U1000 CAN COMMUNICATION LINE"](#) .
- NO >> GO TO 2.

2. CHECK A/T FLUID LEVEL

Check A/T fluid level. Refer to [AT-12, "Checking A/T Fluid"](#) .

OK or NG

- OK >> GO TO 3.
NG >> Refill ATF.

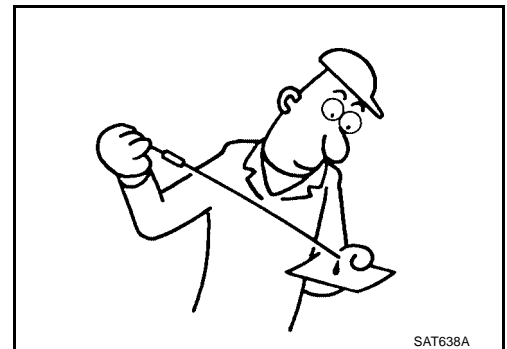

TROUBLE DIAGNOSIS FOR SYMPTOMS

3. CHECK LINE PRESSURE

Check line pressure at the engine stall point. Refer to [AT-53, "LINE PRESSURE TEST"](#) .

OK or NG

- OK >> GO TO 6.
- NG - 1 >> Line pressure high. GO TO 4.
- NG - 2 >> Line pressure low. GO TO 5.

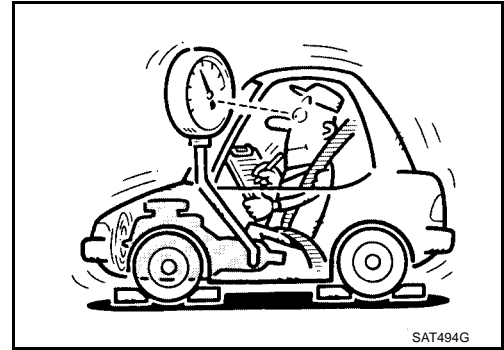

4. DETECT MALFUNCTIONING ITEM

1. Control valve with TCM. Refer to [AT-250, "CONTROL VALVE WITH TCM REMOVAL AND INSTALLATION"](#) .
2. Disassemble A/T. Refer to [AT-283, "DISASSEMBLY"](#) .
3. Check the following items:
 - Oil pump assembly. Refer to [AT-300, "Oil Pump"](#) .

OK or NG

- OK >> GO TO 7.
- NG >> Repair or replace damaged parts.

5. DETECT MALFUNCTIONING ITEM

1. Control valve with TCM. Refer to [AT-250, "CONTROL VALVE WITH TCM REMOVAL AND INSTALLATION"](#) .
2. Disassemble A/T. Refer to [AT-283, "DISASSEMBLY"](#) .
3. Check the following items:
 - Oil pump assembly. Refer to [AT-300, "Oil Pump"](#) .
 - Power train system. Refer to [AT-283, "DISASSEMBLY"](#) .
 - Transmission case. Refer to [AT-283, "DISASSEMBLY"](#) .

OK or NG

- OK >> GO TO 7.
- NG >> Repair or replace damaged parts.

6. CHECK A/T FLUID CONDITION

1. Remove oil pan. Refer to [AT-250, "Control Valve With TCM and A/T Fluid Temperature Sensor 2"](#) .
2. Check A/T fluid condition. Refer to [AT-52, "Fluid Condition Check"](#) .

OK or NG

- OK >> GO TO 7.
- NG >> GO TO 10.

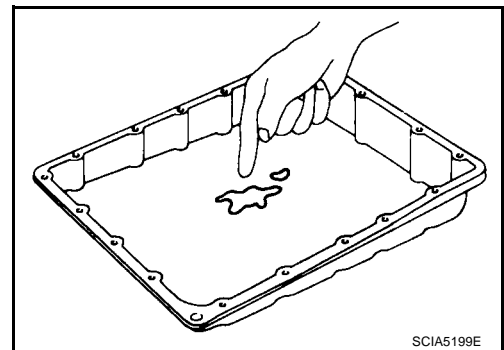

TROUBLE DIAGNOSIS FOR SYMPTOMS

7. DETECT MALFUNCTIONING ITEM

- Check the malfunction items. If any items are damaged, repair or replace damaged parts. Refer to [AT-63, "Symptom Chart"](#) (Symptom No.24).

OK or NG

- OK >> GO TO 8.
- NG >> Repair or replace damaged parts.

8. CHECK SYMPTOM

Check again. Refer to [AT-57, "Cruise Test - Part 1"](#) .

OK or NG

- OK >> **INSPECTION END**
- NG >> GO TO 9.

9. PERFORM TCM INSPECTION

1. Perform TCM input/output signals inspection. Refer to [AT-84, "TCM Input/Output Signal Reference Values"](#) .
2. If NG, recheck A/T assembly harness connector terminals for damage or loose connection with harness connector.

OK or NG

- OK >> **INSPECTION END**
- NG >> Repair or replace damaged parts.

10. DETECT MALFUNCTIONING ITEM

- Check the malfunction items. If any items are damaged, repair or replace damaged parts. Refer to [AT-63, "Symptom Chart"](#) (Symptom No.24).

OK or NG

- OK >> GO TO 8.
- NG >> Repair or replace damaged parts.

A/T Does Not Hold Lock-up Condition SYMPTOM:

ECS00B2T

The lock-up condition cannot be maintained for more than 30 seconds.

DIAGNOSTIC PROCEDURE

1. CHECK SELF-DIAGNOSTIC RESULTS

Perform self-diagnosis. Refer to [AT-87, "SELF-DIAGNOSTIC RESULT MODE"](#) .

Do the self-diagnostic results indicate torque converter clutch solenoid valve, engine speed signal, turbine revolution sensor, CAN communication?

- YES >> Check the malfunctioning system. Refer to [AT-116, "DTC P0740 TORQUE CONVERTER CLUTCH SOLENOID VALVE"](#) , [AT-114, "DTC P0725 ENGINE SPEED SIGNAL"](#) , [AT-132, "DTC P1716 TURBINE REVOLUTION SENSOR"](#) , [AT-97, "DTC U1000 CAN COMMUNICATION LINE"](#)

- NO >> GO TO 2.

TROUBLE DIAGNOSIS FOR SYMPTOMS

2. CHECK A/T FLUID LEVEL

Check A/T fluid level. Refer to [AT-12, "Checking A/T Fluid"](#) .

OK or NG

- OK >> GO TO 3.
- NG >> Refill ATF.

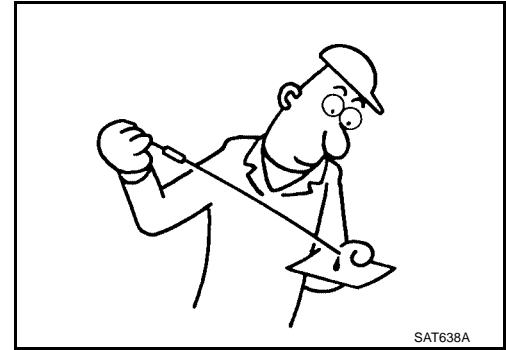

3. CHECK A/T FLUID CONDITION

1. Remove oil pan. Refer to [AT-250, "Control Valve With TCM and A/T Fluid Temperature Sensor 2"](#) .
2. Check A/T fluid condition. Refer to [AT-52, "Fluid Condition Check"](#) .

OK or NG

- OK >> GO TO 4.
- NG >> GO TO 7.

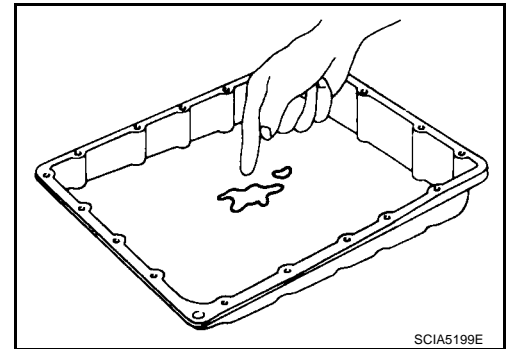

4. DETECT MALFUNCTIONING ITEM

- Check the malfunction items. If any items are damaged, repair or replace damaged parts. Refer to [AT-63, "Symptom Chart"](#) (Symptom No.25).

OK or NG

- OK >> GO TO 5.
- NG >> Repair or replace damaged parts.

5. CHECK SYMPTOM

Check again. Refer to [AT-57, "Cruise Test - Part 1"](#) .

OK or NG

- OK >> **INSPECTION END**
- NG >> GO TO 6.

6. PERFORM TCM INSPECTION

1. Perform TCM input/output signals inspection. Refer to [AT-84, "TCM Input/Output Signal Reference Values"](#) .
2. If NG, recheck A/T assembly harness connector terminals for damage or loose connection with harness connector.

OK or NG

- OK >> **INSPECTION END**
- NG >> Repair or replace damaged parts.

TROUBLE DIAGNOSIS FOR SYMPTOMS

7. DETECT MALFUNCTIONING ITEM

- Check the malfunction items. If any items are damaged, repair or replace damaged parts. Refer to [AT-63, "Symptom Chart"](#) (Symptom No.25).

OK or NG

- OK >> GO TO 5.
- NG >> Repair or replace damaged parts.

Lock-up Is Not Released SYMPTOM:

ECS00B2U

The lock-up condition cannot be cancelled even after releasing the accelerator pedal.

DIAGNOSTIC PROCEDURE

1. CHECK SELF-DIAGNOSTIC RESULTS

Perform self-diagnosis. Refer to [AT-87, "SELF-DIAGNOSTIC RESULT MODE"](#) .

Do the self-diagnostic results indicate torque converter clutch solenoid valve, engine speed signal, turbine revolution sensor, CAN communication?

- YES >> Check the malfunctioning system. Refer to [AT-116, "DTC P0740 TORQUE CONVERTER CLUTCH SOLENOID VALVE"](#) , [AT-114, "DTC P0725 ENGINE SPEED SIGNAL"](#) , [AT-132, "DTC P1716 TURBINE REVOLUTION SENSOR"](#) , [AT-97, "DTC U1000 CAN COMMUNICATION LINE"](#)

- NO >> GO TO 2.

2. CHECK SYMPTOM

Check again. Refer to [AT-57, "Cruise Test - Part 1"](#) .

OK or NG

- OK >> **INSPECTION END**
- NG >> GO TO 3.

3. PERFORM TCM INSPECTION

1. Perform TCM input/output signals inspection. Refer to [AT-84, "TCM Input/Output Signal Reference Values"](#) .
2. If NG, recheck A/T assembly harness connector terminals for damage or loose connection with harness connector.

OK or NG

- OK >> **INSPECTION END**
- NG >> Repair or replace damaged parts.

TROUBLE DIAGNOSIS FOR SYMPTOMS

ECS00B2V

Engine Speed Does Not Return To Idle

SYMPTOM:

When a shift-down is performed, the engine speed does not smoothly return to the idling speed.

DIAGNOSTIC PROCEDURE

1. CHECK A/T FLUID LEVEL

Check A/T fluid level. Refer to [AT-12, "Checking A/T Fluid"](#) .

OK or NG

- OK >> GO TO 2.
- NG >> Refill ATF.

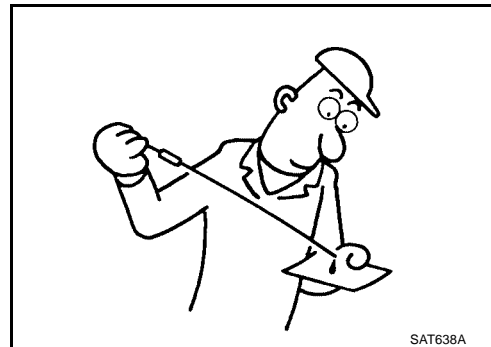

2. CHECK SELF-DIAGNOSTIC RESULTS

Perform self-diagnosis. Refer to [AT-87, "SELF-DIAGNOSTIC RESULT MODE"](#) .

Do the self-diagnostic results indicate front brake solenoid valve, direct clutch solenoid valve, ATF pressure switch 1, ATF pressure switch 5, accelerator pedal position sensor, vehicle speed sensor A/T (revolution sensor) and vehicle speed sensor MTR?

- YES >> Check the malfunctioning system. Refer to [AT-145, "DTC P1757 FRONT BRAKE SOLENOID VALVE"](#) , [AT-149, "DTC P1762 DIRECT CLUTCH SOLENOID VALVE"](#) , [AT-166, "DTC P1841 ATF PRESSURE SWITCH 1"](#) , [AT-170, "DTC P1845 ATF PRESSURE SWITCH 5"](#) , [AT-124, "DTC P1705 THROTTLE POSITION SENSOR"](#) , [AT-109, "DTC P0720 VEHICLE SPEED SENSOR A/T \(REVOLUTION SENSOR\)"](#) , [AT-134, "DTC P1721 VEHICLE SPEED SENSOR MTR"](#) .
- NO >> GO TO 3.

3. CHECK A/T FLUID CONDITION

1. Remove oil pan. Refer to [AT-250, "Control Valve With TCM and A/T Fluid Temperature Sensor 2"](#) .
2. Check A/T fluid condition. Refer to [AT-52, "Fluid Condition Check"](#) .

OK or NG

- OK >> GO TO 4.
- NG >> GO TO 7.

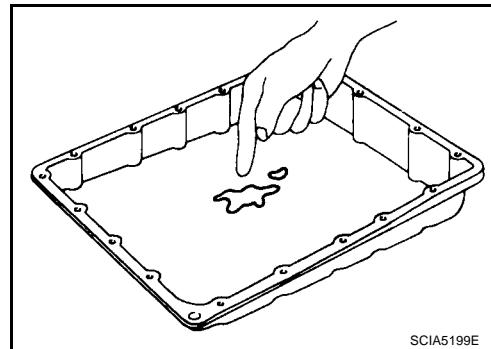

4. DETECT MALFUNCTIONING ITEM

- Check the malfunction items. If any items are damaged, repair or replace damaged parts. Refer to [AT-63, "Symptom Chart"](#) (Symptom No.72).

OK or NG

- OK >> GO TO 5.
- NG >> Repair or replace damaged parts.

TROUBLE DIAGNOSIS FOR SYMPTOMS

5. CHECK SYMPTOM

Check again. Refer to [AT-57, "Cruise Test - Part 1"](#) .

OK or NG

- OK >> **INSPECTION END**
- NG >> GO TO 6.

6. PERFORM TCM INSPECTION

1. Perform TCM input/output signals inspection. Refer to [AT-84, "TCM Input/Output Signal Reference Values"](#) .
2. If NG, recheck A/T assembly harness connector terminals for damage or loose connection with harness connector.

OK or NG

- OK >> **INSPECTION END**
- NG >> Repair or replace damaged parts.

7. DETECT MALFUNCTIONING ITEM

- Check the malfunction items. If any items are damaged, repair or replace damaged parts. Refer to [AT-63, "Symptom Chart"](#) (Symptom No.72).

OK or NG

- OK >> GO TO 5.
- NG >> Repair or replace damaged parts.

Cannot Be Changed to Manual Mode (Column Shift) SYMPTOM:

ECS00B2W

Does not change to manual mode when manual shift gate is used.

DIAGNOSTIC PROCEDURE

1. MANUAL MODE SWITCH

Check the manual mode switch. Refer to [AT-161, "DTC P1815 MANUAL MODE SWITCH"](#) .

OK or NG

- OK >> GO TO 2.
- NG >> Repair or replace damaged parts.

2. CHECK SELF-DIAGNOSIS RESULTS

Perform self-diagnosis. Refer to [AT-87, "SELF-DIAGNOSTIC RESULT MODE"](#) .

Do the self-diagnosis results indicate turbine revolution sensor?

- YES >> Check the malfunctioning system. Refer to [AT-132, "DTC P1716 TURBINE REVOLUTION SENSOR"](#) .
- NO >> **INSPECTION END**

A/T Does Not Shift: 5th gear → 4th gear (Floor Shift Models) SYMPTOM:

ECS00B2X

When shifted from D5 to 44 position, does not downshift from 5th to 4th gears.

DIAGNOSTIC PROCEDURE

1. CHECK SELF-DIAGNOSIS RESULTS

Perform self-diagnosis. Refer to [AT-87, "SELF-DIAGNOSTIC RESULT MODE"](#) .

Do the self-diagnosis results indicate PNP switch, ATF pressure switch 1?

- YES >> Check the malfunctioning system. Refer to [AT-105, "DTC P0705 PARK/NEUTRAL POSITION SWITCH"](#) , [AT-166, "DTC P1841 ATF PRESSURE SWITCH 1"](#) .
- NO >> GO TO 2.

TROUBLE DIAGNOSIS FOR SYMPTOMS

2. CHECK 4TH POSITION SWITCH CIRCUIT

① With CONSULT-II

1. Turn ignition switch "ON".
2. Select "ECU INPUT SIGNALS" in "DATA MONITOR" mode for "A/T" with CONSULT-II.
3. Read out "OD CONT SW" switch moving selector lever to each position.

Monitor item	Condition	Display value
OD CONT SW	When setting the selector lever to "4" and "3" positions.	ON
	When setting selector lever to other positions.	OFF

DATA MONITOR	
MONITORING	
1 POSITION SW	OFF
OD CONT SW	ON
POWERSHIFT SW	OFF
HOLD SW	OFF
MANU MODE SW	OFF

LCIA0339E

⊗ Without CONSULT-II

1. Turn ignition switch "ON". (Do not start engine)
2. Check voltage between A/T device harness connector terminal and ground.

Item	Connector No.	Terminal No. (Wire color)	Condition	Data (Approx.)
4th position switch	M203	1 (SB) - Ground	When setting the selector lever to "4" and "3" positions.	0V
			When setting selector lever to other positions.	Battery voltage

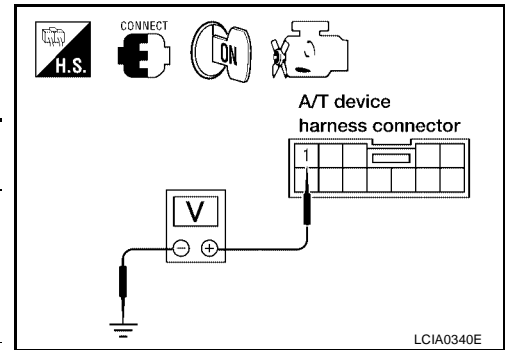

OK or NG

- OK >> GO TO 3.
- NG >> Repair or replace damaged parts.

3. CHECK A/T FLUID LEVEL

Check the A/T fluid level. Refer to [AT-12. "Checking A/T Fluid"](#).

OK or NG

- OK >> GO TO 4.
- NG >> Refill ATF.

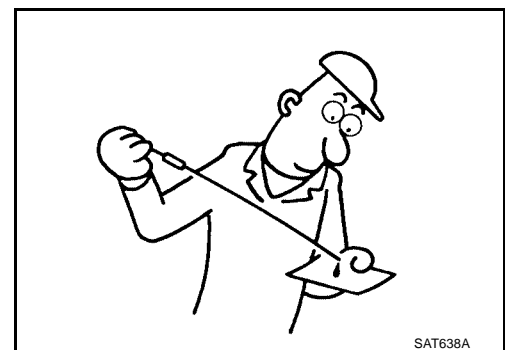

TROUBLE DIAGNOSIS FOR SYMPTOMS

4. CHECK CONTROL CABLE

Check the control cable.

- Refer to [AT-238, "Checking of A/T Position"](#) .

OK or NG

OK >> GO TO 5.

NG >> Adjust control cable. Refer to [AT-238, "Adjustment of A/T Position"](#) .

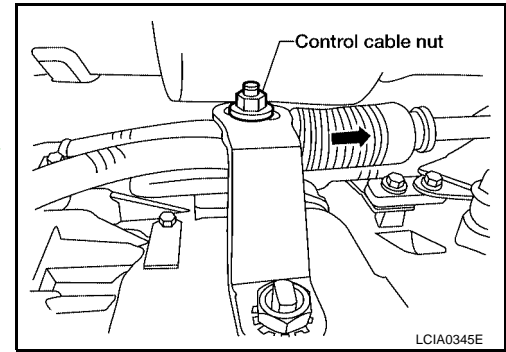

5. CHECK A/T FLUID CONDITION

1. Remove oil pan. Refer to [AT-250, "Control Valve With TCM and A/T Fluid Temperature Sensor 2"](#) .
2. Check A/T fluid condition. Refer to [AT-52, "Fluid Condition Check"](#) .

OK or NG

OK >> GO TO 6.

NG >> GO TO 9.

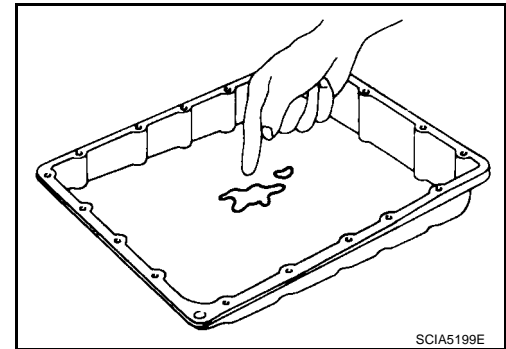

6. DETECT MALFUNCTIONING ITEM

- Check the malfunction items. If any items are damaged, repair or replace damaged parts. Refer to [AT-63, "Symptom Chart"](#) (Symptom No.14).

OK or NG

OK >> GO TO 7.

NG >> Repair or replace damaged parts.

7. CHECK SYMPTOM

Check again. Refer to [AT-60, "Cruise Test - Part 3"](#) .

OK or NG

OK >> **INSPECTION END**

NG >> GO TO 8.

8. PERFORM TCM INSPECTION

1. Perform TCM input/output signals inspection. Refer to [AT-84, "TCM Input/Output Signal Reference Values"](#) .
2. If NG, recheck A/T assembly harness connector terminals for damage or loose connection with harness connector.

OK or NG

OK >> **INSPECTION END**

NG >> Repair or replace damaged parts.

A
B
AT
D
E
F
G
H
I
J
K
L
M

TROUBLE DIAGNOSIS FOR SYMPTOMS

9. DETECT MALFUNCTIONING ITEM

- Check the malfunction items. If any items are damaged, repair or replace damaged parts. Refer to [AT-63, "Symptom Chart"](#) (Symptom No.14).

OK or NG

- OK >> GO TO 7.
- NG >> Repair or replace damaged parts.

A/T Does Not Shift: 5th gear → 4th gear (Column Shift Models)

ECS00CCO

SYMPTOM:

When shifted from 5M to 4M position in manual mode, does not downshift from 5th to 4th gear.

DIAGNOSTIC PROCEDURE

1. CHECK SELF-DIAGNOSTIC RESULTS

Perform self-diagnosis. Refer to [AT-87, "SELF-DIAGNOSTIC RESULT MODE"](#) .

Do the self-diagnostic results indicate PNP switch, ATF pressure switch 1?

- YES >> Check the malfunctioning system. Refer to [AT-105, "DTC P0705 PARK/NEUTRAL POSITION SWITCH"](#) , [AT-166, "DTC P1841 ATF PRESSURE SWITCH 1"](#) .
- NO >> GO TO 2.

2. CHECK A/T FLUID LEVEL

Check A/T fluid level. Refer to [AT-12, "Checking A/T Fluid"](#) .

OK or NG

- OK >> GO TO 3.
- NG >> Refill ATF.

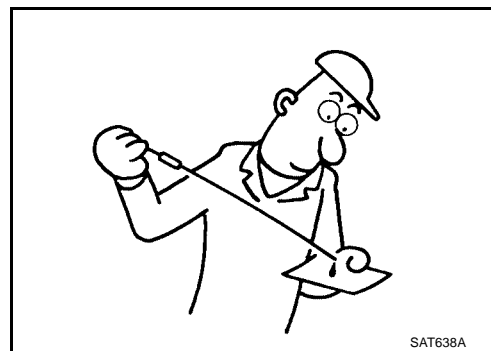

SAT638A

3. CHECK CONTROL LINKAGE

Check the control linkage.

- Refer to [AT-238, "Checking of A/T Position"](#) .

OK or NG

- OK >> GO TO 4.
- NG >> Adjust control linkage. Refer to [AT-238, "Adjustment of A/T Position"](#) .

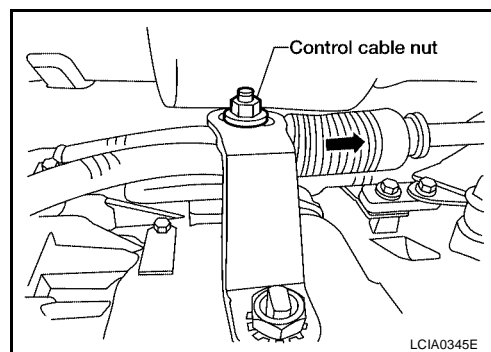

LCIA0345E

4. MANUAL MODE SWITCH

Check the manual mode switch. Refer to [AT-161, "DTC P1815 MANUAL MODE SWITCH"](#) .

OK or NG

- OK >> GO TO 5.
- NG >> Repair or replace damaged parts.

TROUBLE DIAGNOSIS FOR SYMPTOMS

5. CHECK A/T FLUID CONDITION

1. Remove oil pan. Refer to [AT-250, "Control Valve With TCM and A/T Fluid Temperature Sensor 2"](#) .
2. Check A/T fluid condition. Refer to [AT-52, "Fluid Condition Check"](#) .

OK or NG

- OK >> GO TO 6.
- NG >> GO TO 9.

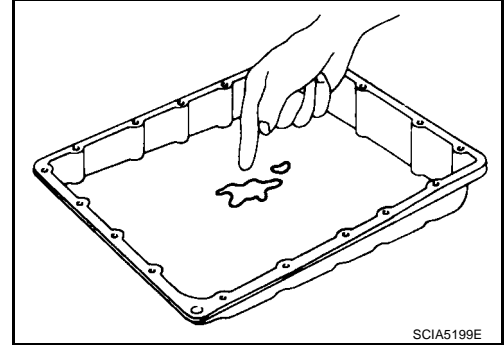

6. DETECT MALFUNCTIONING ITEM

- Check the malfunction items. If any items are damaged, repair or replace damaged parts. Refer to [AT-63, "Symptom Chart"](#) (Symptom No.14).

OK or NG

- OK >> GO TO 7.
- NG >> Repair or replace damaged parts.

7. CHECK SYMPTOM

Check again. Refer to [AT-60, "Cruise Test - Part 3"](#) .

OK or NG

- OK >> **INSPECTION END**
- NG >> GO TO 8.

8. CHECK TCM

1. Check TCM input/output signals. Refer to [AT-84, "TCM Input/Output Signal Reference Values"](#) .
2. If NG, recheck A/T assembly harness connector terminals for damage or loose connection with harness connector.

OK or NG

- OK >> **INSPECTION END**
- NG >> Repair or replace damaged parts.

9. DETECT MALFUNCTIONING ITEM

- Check the malfunction items. If any items are damaged, repair or replace damaged parts. Refer to [AT-63, "Symptom Chart"](#) (Symptom No.14).

OK or NG

- OK >> GO TO 7.
- NG >> Repair or replace damaged parts.

TROUBLE DIAGNOSIS FOR SYMPTOMS

ECS00B2Y

A/T Does Not Shift: 4th gear → 3rd gear (Floor Shift Models)

SYMPTOM:

When shifted from 44 to 33 position, does not downshift from 4th to 3rd gears.

DIAGNOSTIC PROCEDURE

1. CHECK SELF-DIAGNOSIS RESULTS

Perform self-diagnosis. Refer to [AT-87, "SELF-DIAGNOSTIC RESULT MODE"](#).

Do the self-diagnosis results indicate PNP switch, ATF pressure switch 1, ATF pressure switch 3?

YES >> Check the malfunctioning system. Refer to [AT-105, "DTC P0705 PARK/NEUTRAL POSITION SWITCH"](#), [AT-166, "DTC P1841 ATF PRESSURE SWITCH 1"](#), [AT-168, "DTC P1843 ATF PRESSURE SWITCH 3"](#).

NO >> GO TO 2.

2. CHECK A/T FLUID LEVEL

Check the A/T fluid level. Refer to [AT-12, "Checking A/T Fluid"](#).

OK or NG

OK >> GO TO 3.

NG >> Refill ATF.

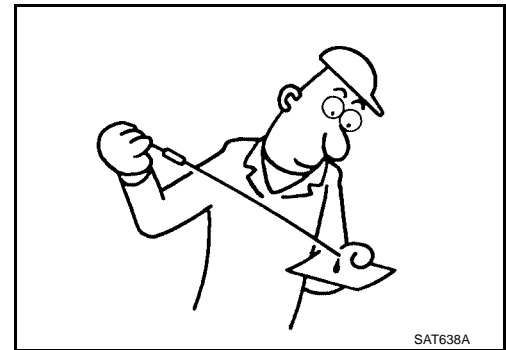

3. CHECK CONTROL CABLE

Check the control cable.

- Refer to [AT-238, "Checking of A/T Position"](#).

OK or NG

OK >> GO TO 4.

NG >> Adjust control cable. Refer to [AT-238, "Adjustment of A/T Position"](#).

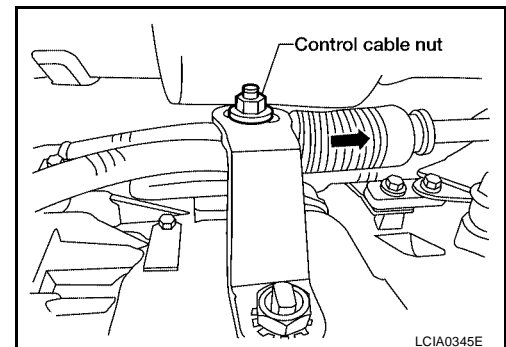

4. CHECK A/T FLUID CONDITION

1. Remove oil pan. Refer to [AT-250, "Control Valve With TCM and A/T Fluid Temperature Sensor 2"](#).

2. Check A/T fluid condition. Refer to [AT-52, "Fluid Condition Check"](#).

OK or NG

OK >> GO TO 5.

NG >> GO TO 8.

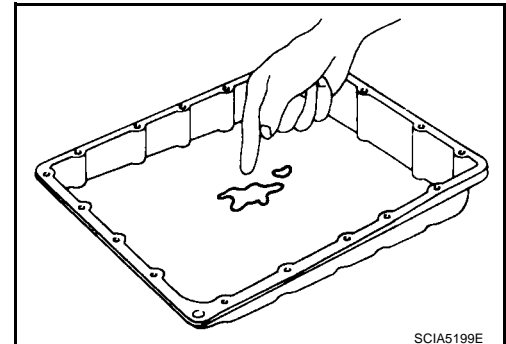

TROUBLE DIAGNOSIS FOR SYMPTOMS

5. DETECT MALFUNCTIONING ITEM

- Check the malfunction items. If any items are damaged, repair or replace damaged parts. Refer to [AT-63, "Symptom Chart"](#) (Symptom No.15).

OK or NG

- OK >> GO TO 6.
- NG >> Repair or replace damaged parts.

6. CHECK SYMPTOM

Check again. Refer to [AT-60, "Cruise Test - Part 3"](#) .

OK or NG

- OK >> **INSPECTION END**
- NG >> GO TO 7.

7. PERFORM TCM INSPECTION

1. Perform TCM input/output signals inspection. Refer to [AT-84, "TCM Input/Output Signal Reference Values"](#) .
2. If NG, recheck A/T assembly harness connector terminals for damage or loose connection with harness connector.

OK or NG

- OK >> **INSPECTION END**
- NG >> Repair or replace damaged parts.

8. DETECT MALFUNCTIONING ITEM

- Check the malfunction items. If any items are damaged, repair or replace damaged parts. Refer to [AT-63, "Symptom Chart"](#) (Symptom No.15).

OK or NG

- OK >> GO TO 6.
- NG >> Repair or replace damaged parts.

A
B
AT
D
E
F
G
H
I
J
K
L
M

TROUBLE DIAGNOSIS FOR SYMPTOMS

A/T Does Not Shift: 4th gear → 3rd gear (Column Shift Models)

ECS00CCP

SYMPTOM:

When shifted from 4M to 3M position in manual mode, does not downshift from 4th to 3rd gear.

DIAGNOSTIC PROCEDURE

1. CHECK SELF-DIAGNOSTIC RESULTS

Perform self-diagnosis. Refer to [AT-87, "SELF-DIAGNOSTIC RESULT MODE"](#) .

Do the self-diagnostic results indicate PNP switch, ATF pressure switch 1, ATF pressure switch 3?

YES >> Check the malfunctioning system. Refer to [AT-105, "DTC P0705 PARK/NEUTRAL POSITION SWITCH"](#) , [AT-166, "DTC P1841 ATF PRESSURE SWITCH 1"](#) , [AT-168, "DTC P1843 ATF PRES-SURE SWITCH 3"](#) .

NO >> GO TO 2.

2. CHECK A/T FLUID LEVEL

Check A/T fluid level. Refer to [AT-12, "Checking A/T Fluid"](#) .

OK or NG

OK >> GO TO 3.

NG >> Refill ATF.

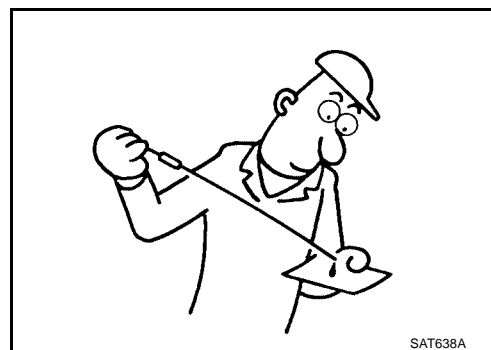

3. CHECK CONTROL LINKAGE

Check the control linkage.

- Refer to [AT-238, "Checking of A/T Position"](#) .

OK or NG

OK >> GO TO 4.

NG >> Adjust control linkage. Refer to [AT-238, "Adjustment of A/T Position"](#) .

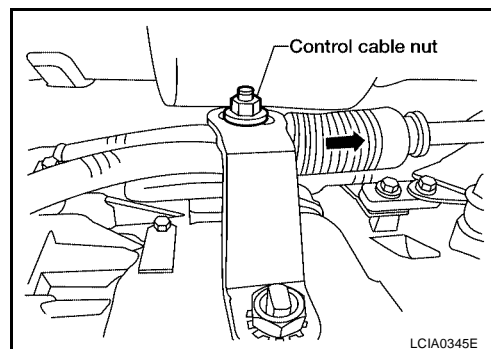

4. MANUAL MODE SWITCH

Check the manual mode switch. Refer to [AT-161, "DTC P1815 MANUAL MODE SWITCH"](#) .

OK or NG

OK >> GO TO 5.

NG >> Repair or replace damaged parts.

TROUBLE DIAGNOSIS FOR SYMPTOMS

5. CHECK A/T FLUID CONDITION

1. Remove oil pan. Refer to [AT-250, "Control Valve With TCM and A/T Fluid Temperature Sensor 2"](#) .
2. Check A/T fluid condition. Refer to [AT-52, "Fluid Condition Check"](#) .

OK or NG

- OK >> GO TO 6.
- NG >> GO TO 9.

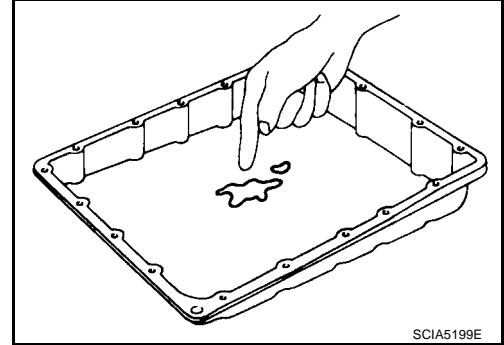

6. DETECT MALFUNCTIONING ITEM

- Check the malfunction items. If any items are damaged, repair or replace damaged parts. Refer to [AT-63, "Symptom Chart"](#) (Symptom No.15).

OK or NG

- OK >> GO TO 7.
- NG >> Repair or replace damaged parts.

7. CHECK SYMPTOM

Check again. Refer to [AT-60, "Cruise Test - Part 3"](#) .

OK or NG

- OK >> **INSPECTION END**
- NG >> GO TO 8.

8. CHECK TCM

1. Check TCM input/output signals. Refer to [AT-84, "TCM Input/Output Signal Reference Values"](#) .
2. If NG, recheck A/T assembly harness connector terminals for damage or loose connection with harness connector.

OK or NG

- OK >> **INSPECTION END**
- NG >> Repair or replace damaged parts.

9. DETECT MALFUNCTIONING ITEM

- Check the malfunction items. If any items are damaged, repair or replace damaged parts. Refer to [AT-63, "Symptom Chart"](#) (Symptom No.15).

OK or NG

- OK >> GO TO 7.
- NG >> Repair or replace damaged parts.

TROUBLE DIAGNOSIS FOR SYMPTOMS

ECS00B2Z

A/T Does Not Shift: 3rd gear → 2nd gear (Floor Shift Models)

SYMPTOM:

When shifted from 3rd to 2nd position, does not downshift from 3rd to 2nd gears.

DIAGNOSTIC PROCEDURE

1. CHECK SELF-DIAGNOSIS RESULTS

Perform self-diagnosis. Refer to [AT-87, "SELF-DIAGNOSTIC RESULT MODE"](#) .

Do the self-diagnosis results indicate PNP switch, ATF pressure switch 6?

YES >> Check the malfunctioning system. Refer to [AT-105, "DTC P0705 PARK/NEUTRAL POSITION SWITCH"](#) , [AT-172, "DTC P1846 ATF PRESSURE SWITCH 6"](#) .

NO >> GO TO 2.

2. CHECK A/T FLUID LEVEL

Check the A/T fluid level. Refer to [AT-12, "Checking A/T Fluid"](#) .

OK or NG

OK >> GO TO 3.

NG >> Refill ATF.

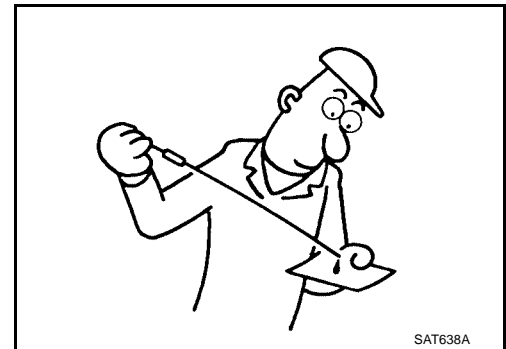

3. CHECK CONTROL CABLE

Check the control cable.

- Refer to [AT-238, "Checking of A/T Position"](#) .

OK or NG

OK >> GO TO 4.

NG >> Adjust control cable. Refer to [AT-238, "Adjustment of A/T Position"](#) .

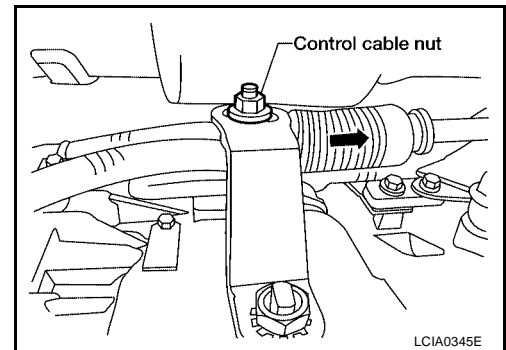

4. CHECK A/T FLUID CONDITION

1. Remove oil pan. Refer to [AT-250, "Control Valve With TCM and A/T Fluid Temperature Sensor 2"](#) .

2. Check A/T fluid condition. Refer to [AT-52, "Fluid Condition Check"](#) .

OK or NG

OK >> GO TO 5.

NG >> GO TO 8.

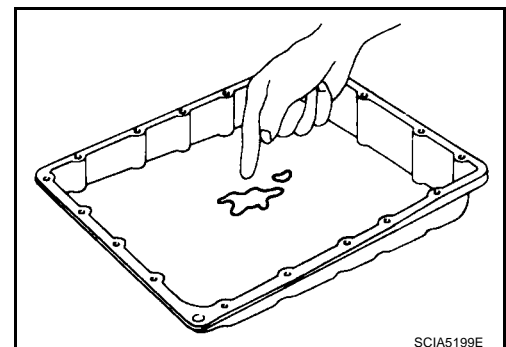

TROUBLE DIAGNOSIS FOR SYMPTOMS

5. DETECT MALFUNCTIONING ITEM

- Check the malfunction items. If any items are damaged, repair or replace damaged parts. Refer to [AT-63, "Symptom Chart"](#) (Symptom No.16).

OK or NG

- OK >> GO TO 6.
- NG >> Repair or replace damaged parts.

6. CHECK SYMPTOM

Check again. Refer to [AT-60, "Cruise Test - Part 3"](#) .

OK or NG

- OK >> **INSPECTION END**
- NG >> GO TO 7.

7. PERFORM TCM INSPECTION

1. Perform TCM input/output signals inspection. Refer to [AT-84, "TCM Input/Output Signal Reference Values"](#) .
2. If NG, recheck A/T assembly harness connector terminals for damage or loose connection with harness connector.

OK or NG

- OK >> **INSPECTION END**
- NG >> Repair or replace damaged parts.

8. DETECT MALFUNCTIONING ITEM

- Check the malfunction items. If any items are damaged, repair or replace damaged parts. Refer to [AT-63, "Symptom Chart"](#) (Symptom No.16).

OK or NG

- OK >> GO TO 6.
- NG >> Repair or replace damaged parts.

A
B
AT
D
E
F
G
H
I
J
K
L
M

TROUBLE DIAGNOSIS FOR SYMPTOMS

A/T Does Not Shift: 3rd gear → 2nd gear (Column Shift Models)

ECS00CCQ

SYMPTOM:

When shifted from 3M to 2M position in manual mode, does not downshift from 3rd to 2nd gear.

DIAGNOSTIC PROCEDURE

1. CHECK SELF-DIAGNOSTIC RESULTS

Perform self-diagnosis. Refer to [AT-87, "SELF-DIAGNOSTIC RESULT MODE"](#) .

Do the self-diagnostic results indicate PNP switch, ATF pressure switch 6?

- YES >> Check the malfunctioning system. Refer to [AT-105, "DTC P0705 PARK/NEUTRAL POSITION SWITCH"](#) , [AT-172, "DTC P1846 ATF PRESSURE SWITCH 6"](#) .
- NO >> GO TO 2.

2. CHECK A/T FLUID LEVEL

Check A/T fluid level. Refer to [AT-12, "Checking A/T Fluid"](#) .

OK or NG

- OK >> GO TO 3.
- NG >> Refill ATF.

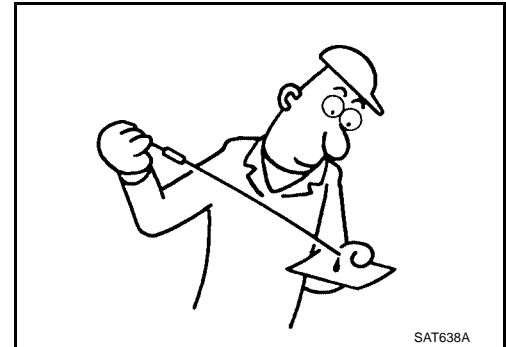

3. CHECK CONTROL LINKAGE

Check the control linkage.

- Refer to [AT-238, "Checking of A/T Position"](#) .

OK or NG

- OK >> GO TO 4.
- NG >> Adjust control linkage. Refer to [AT-238, "Adjustment of A/T Position"](#) .

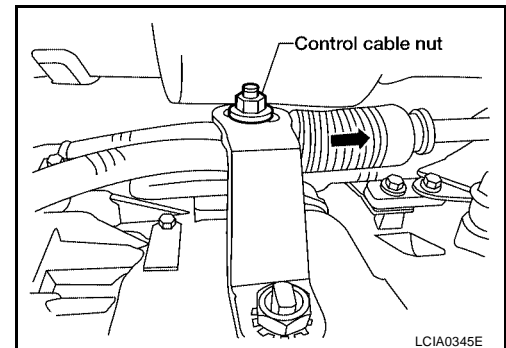

4. MANUAL MODE SWITCH

Check the manual mode switch. Refer to [AT-161, "DTC P1815 MANUAL MODE SWITCH"](#) .

OK or NG

- OK >> GO TO 5.
- NG >> Repair or replace damaged parts.

TROUBLE DIAGNOSIS FOR SYMPTOMS

5. CHECK A/T FLUID CONDITION

1. Remove oil pan. Refer to [AT-250, "Control Valve With TCM and A/T Fluid Temperature Sensor 2"](#) .
2. Check A/T fluid condition. Refer to [AT-52, "Fluid Condition Check"](#) .

OK or NG

- OK >> GO TO 6.
- NG >> GO TO 9.

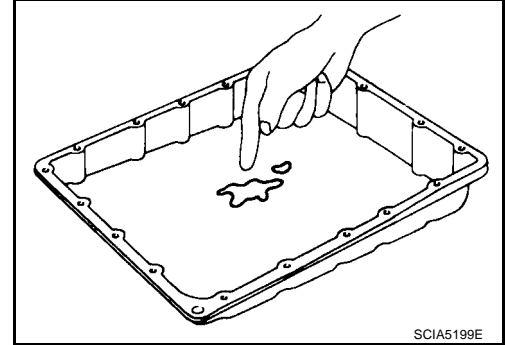

6. DETECT MALFUNCTIONING ITEM

- Check the malfunction items. If any items are damaged, repair or replace damaged parts. Refer to [AT-63, "Symptom Chart"](#) (Symptom No.16).

OK or NG

- OK >> GO TO 7.
- NG >> Repair or replace damaged parts.

7. CHECK SYMPTOM

Check again. Refer to [AT-60, "Cruise Test - Part 3"](#) .

OK or NG

- OK >> **INSPECTION END**
- NG >> GO TO 8.

8. CHECK TCM

1. Check TCM input/output signals. Refer to [AT-84, "TCM Input/Output Signal Reference Values"](#) .
2. If NG, recheck A/T assembly harness connector terminals for damage or loose connection with harness connector.

OK or NG

- OK >> **INSPECTION END**
- NG >> Repair or replace damaged parts.

9. DETECT MALFUNCTIONING ITEM

- Check the malfunction items. If any items are damaged, repair or replace damaged parts. Refer to [AT-63, "Symptom Chart"](#) (Symptom No.16).

OK or NG

- OK >> GO TO 7.
- NG >> Repair or replace damaged parts.

TROUBLE DIAGNOSIS FOR SYMPTOMS

ECS00B30

A/T Does Not Shift: 2nd gear → 1st gear (Floor Shift Models)

SYMPTOM:

When shifted from 22 to 11 position, does not downshift from 2nd to 1st gears.

DIAGNOSTIC PROCEDURE

1. CHECK SELF-DIAGNOSIS RESULTS

Perform self-diagnosis. Refer to [AT-87, "SELF-DIAGNOSTIC RESULT MODE"](#) .

Do the self-diagnosis results indicate PNP switch, ATF pressure switch 5?

YES >> Check the malfunctioning system. Refer to [AT-105, "DTC P0705 PARK/NEUTRAL POSITION SWITCH"](#) , [AT-170, "DTC P1845 ATF PRESSURE SWITCH 5"](#) .

NO >> GO TO 2.

2. CHECK 1ST POSITION SWITCH CIRCUIT

With CONSULT-II

- Turn ignition switch "ON".
- Select "ECU INPUT SIGNALS" in "DATA MONITOR" mode for "A/T" with CONSULT-II.
- Read out "OVERDRIVE SW" switch moving selector lever to each position.

Monitor item	Condition	Display value
1 POSITION SW	When setting the selector lever to "1" position.	ON
	When setting selector lever to other positions.	OFF

DATA MONITOR	
MONITORING	
1 POSITION SW	OFF
OD CONT SW	ON
POWERSHIFT SW	OFF
HOLD SW	OFF
MANU MODE SW	OFF

LCIA0339E

Without CONSULT-II

- Turn ignition switch "ON". (Do not start engine)
- Check voltage between A/T device harness connector terminal and ground.

Item	Connector No.	Terminal No. (Wire color)	Condition	Data (Approx.)
1st position switch	M203	7 (Y/G) - Ground	When setting the selector lever to "1" position.	0V
			When setting selector lever to other positions.	Battery voltage

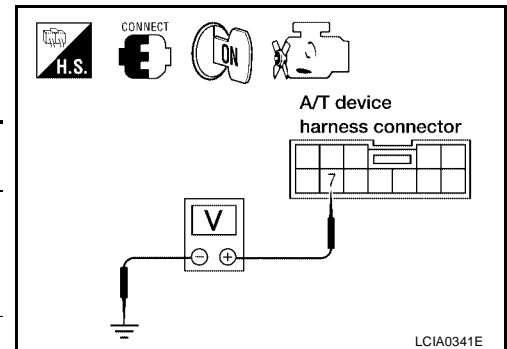

OK or NG

OK >> GO TO 3.

NG >> Repair or replace damaged parts.

TROUBLE DIAGNOSIS FOR SYMPTOMS

3. CHECK A/T FLUID LEVEL

Check the A/T fluid level. Refer to [AT-12, "Checking A/T Fluid"](#).

OK or NG

- OK >> GO TO 4.
- NG >> Refill ATF.

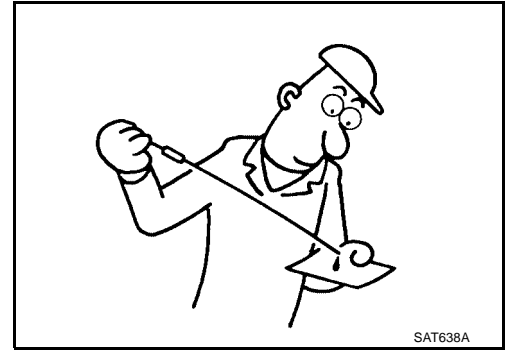

4. CHECK CONTROL CABLE

Check the control cable.

- Refer to [AT-238, "Checking of A/T Position"](#).

OK or NG

- OK >> GO TO 5.
- NG >> Adjust control cable. Refer to [AT-238, "Adjustment of A/T Position"](#).

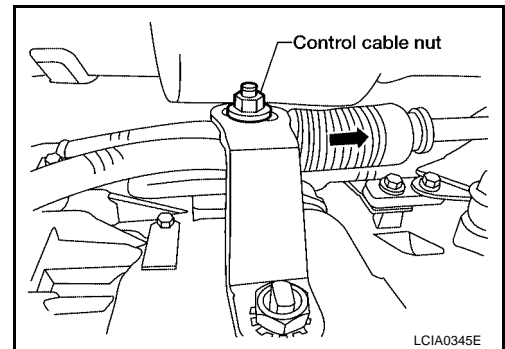

5. CHECK A/T FLUID CONDITION

1. Remove oil pan. Refer to [AT-250, "Control Valve With TCM and A/T Fluid Temperature Sensor 2"](#).
2. Check A/T fluid condition. Refer to [AT-52, "Fluid Condition Check"](#).

OK or NG

- OK >> GO TO 6.
- NG >> GO TO 9.

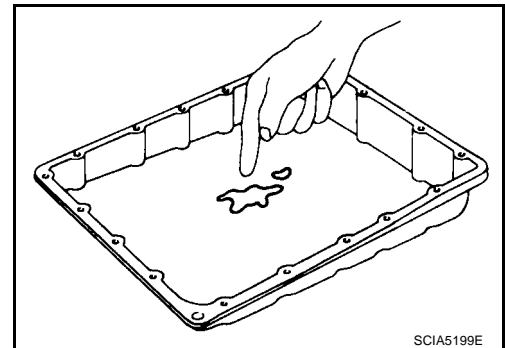

6. DETECT MALFUNCTIONING ITEM

- Check the malfunction items. If any items are damaged, repair or replace damaged parts. Refer to [AT-63, "Symptom Chart"](#) (Symptom No.17).

OK or NG

- OK >> GO TO 7.
- NG >> Repair or replace damaged parts.

7. CHECK SYMPTOM

Check again. Refer to [AT-60, "Cruise Test - Part 3"](#).

OK or NG

- OK >> **INSPECTION END**
- NG >> GO TO 8.

A
B
AT
D
E
F
G
H
I
J
K
L
M

TROUBLE DIAGNOSIS FOR SYMPTOMS

8. PERFORM TCM INSPECTION

1. Perform TCM input/output signals inspection. Refer to [AT-84, "TCM Input/Output Signal Reference Values"](#) .
2. If NG, recheck A/T assembly harness connector terminals for damage or loose connection with harness connector.

OK or NG

- OK >> **INSPECTION END**
NG >> Repair or replace damaged parts.

9. DETECT MALFUNCTIONING ITEM

- Check the malfunction items. If any items are damaged, repair or replace damaged parts. Refer to [AT-63, "Symptom Chart"](#) (Symptom No.17).

OK or NG

- OK >> GO TO 7.
NG >> Repair or replace damaged parts.

TROUBLE DIAGNOSIS FOR SYMPTOMS

A/T Does Not Shift: 2nd gear → 1st gear (Column Shift Models)

ECS00CCR

SYMPTOM:

When shifted from 2M to 1M position in manual mode, does not downshift from 2nd to 1st gear.

DIAGNOSTIC PROCEDURE

1. CHECK SELF-DIAGNOSTIC RESULTS

Perform self-diagnosis. Refer to [AT-87, "SELF-DIAGNOSTIC RESULT MODE"](#) .

Do the self-diagnostic results indicate PNP switch, ATF pressure switch 5?

YES >> Check the malfunctioning system. Refer to [AT-105, "DTC P0705 PARK/NEUTRAL POSITION SWITCH"](#) , [AT-170, "DTC P1845 ATF PRESSURE SWITCH 5"](#) .

NO >> GO TO 2.

2. CHECK A/T FLUID LEVEL

Check A/T fluid level. Refer to [AT-12, "Checking A/T Fluid"](#) .

OK or NG

OK >> GO TO 3.

NG >> Refill ATF.

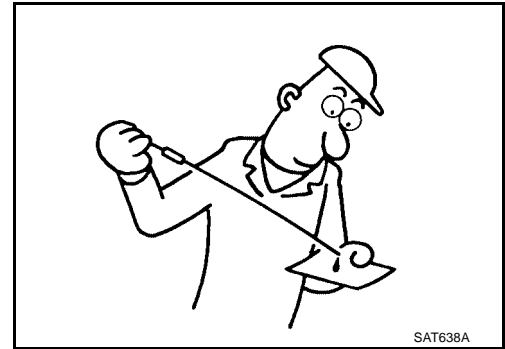

3. CHECK CONTROL LINKAGE

Check the control linkage.

● Refer to [AT-238, "Checking of A/T Position"](#) .

OK or NG

OK >> GO TO 4.

NG >> Adjust control linkage. Refer to [AT-238, "Adjustment of A/T Position"](#) .

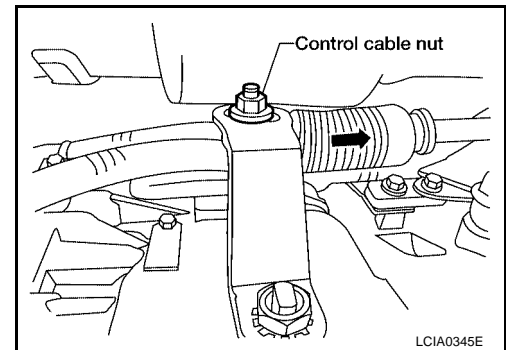

4. MANUAL MODE SWITCH

Check the manual mode switch. Refer to [AT-161, "DTC P1815 MANUAL MODE SWITCH"](#) .

OK or NG

OK >> GO TO 5.

NG >> Repair or replace damaged parts.

TROUBLE DIAGNOSIS FOR SYMPTOMS

5. CHECK A/T FLUID CONDITION

1. Remove oil pan. Refer to [AT-250, "Control Valve With TCM and A/T Fluid Temperature Sensor 2"](#) .
2. Check A/T fluid condition. Refer to [AT-52, "Fluid Condition Check"](#) .

OK or NG

- OK >> GO TO 6.
- NG >> GO TO 9.

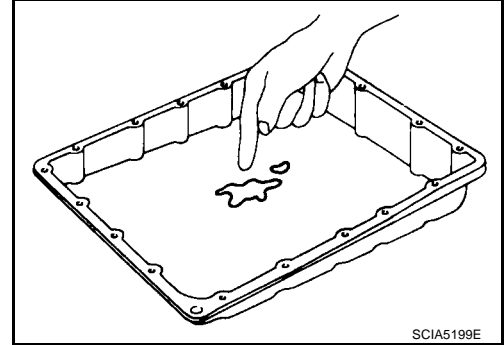

6. DETECT MALFUNCTIONING ITEM

- Check the malfunction items. If any items are damaged, repair or replace damaged parts. Refer to [AT-63, "Symptom Chart"](#) (Symptom No.17).

OK or NG

- OK >> GO TO 7.
- NG >> Repair or replace damaged parts.

7. CHECK SYMPTOM

Check again. Refer to [AT-60, "Cruise Test - Part 3"](#) .

OK or NG

- OK >> **INSPECTION END**
- NG >> GO TO 8.

8. CHECK TCM

1. Check TCM input/output signals. Refer to [AT-84, "TCM Input/Output Signal Reference Values"](#) .
2. If NG, recheck A/T assembly harness connector terminals for damage or loose connection with harness connector.

OK or NG

- OK >> **INSPECTION END**
- NG >> Repair or replace damaged parts.

9. DETECT MALFUNCTIONING ITEM

- Check the malfunction items. If any items are damaged, repair or replace damaged parts. Refer to [AT-63, "Symptom Chart"](#) (Symptom No.17).

OK or NG

- OK >> GO TO 7.
- NG >> Repair or replace damaged parts.

TROUBLE DIAGNOSIS FOR SYMPTOMS

ECS00B31

Vehicle Does Not Decelerate By Engine Brake

SYMPTOM:

No engine brake is applied when the gear is shifted from the 22 to 11 .

DIAGNOSTIC PROCEDURE

1. CHECK SELF-DIAGNOSIS RESULTS

Perform self-diagnosis.

Do the self-diagnosis results indicate PNP switch, ATF pressure switch 5?

- YES >> Check the malfunctioning system. Refer to [AT-105, "DTC P0705 PARK/NEUTRAL POSITION SWITCH"](#) , [AT-170, "DTC P1845 ATF PRESSURE SWITCH 5"](#) .
- NO >> GO TO 2.

2. CHECK 1ST POSITION SWITCH CIRCUIT

With CONSULT-II

- Turn ignition switch "ON".
- Select "ECU INPUT SIGNALS" in "DATA MONITOR" mode for "A/T" with CONSULT-II.
- Read out "OVERDRIVE SW" switch moving selector lever to each position.

Monitor item	Condition	Display value
1 POSITION SW	When setting the selector lever to "1" position.	ON
	When setting selector lever to other positions.	OFF

DATA MONITOR	
MONITORING	
1 POSITION SW	OFF
OD CONT SW	ON
POWERSHIFT SW	OFF
HOLD SW	OFF
MANU MODE SW	OFF

LCIA0339E

Without CONSULT-II

- Turn ignition switch "ON". (Do not start engine)
- Check voltage between A/T device harness connector terminal and ground.

Item	Connector No.	Terminal No. (Wire color)	Condition	Data (Approx.)
1st position switch	M203	7 (Y/G) - Ground	When setting the selector lever to "1" position.	0V
			When setting selector lever to other positions.	Battery voltage

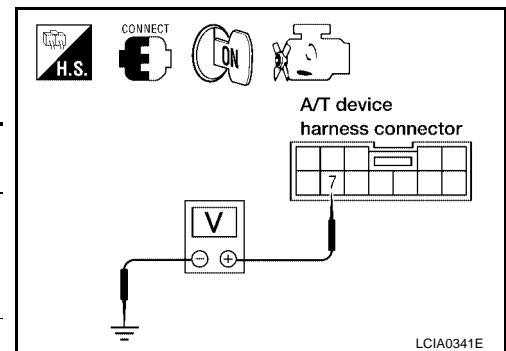

OK or NG

- OK >> GO TO 3.
- NG >> Repair or replace damaged parts.

TROUBLE DIAGNOSIS FOR SYMPTOMS

3. CHECK A/T FLUID LEVEL

Check the A/T fluid level. Refer to [AT-12, "Checking A/T Fluid"](#) .

OK or NG

- OK >> GO TO 4.
- NG >> Refill ATF.

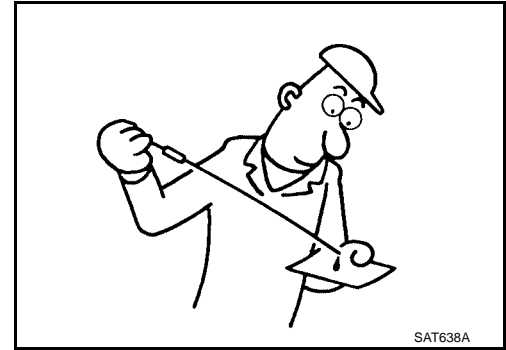

4. CHECK CONTROL CABLE

Check the control cable.

- Refer to [AT-238, "Checking of A/T Position"](#) .

OK or NG

- OK >> GO TO 5.
- NG >> Adjust control cable. Refer to [AT-238, "Adjustment of A/T Position"](#) .

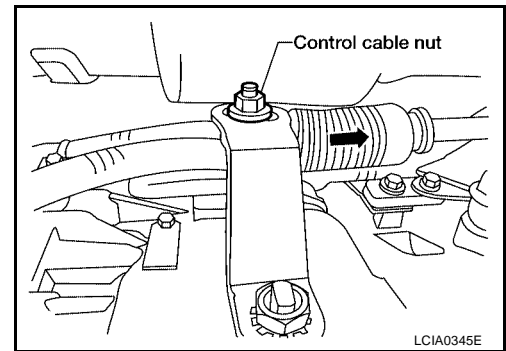

5. CHECK A/T FLUID CONDITION

1. Remove oil pan. Refer to [AT-250, "Control Valve With TCM and A/T Fluid Temperature Sensor 2"](#) .
2. Check A/T fluid condition. Refer to [AT-52, "Fluid Condition Check"](#) .

OK or NG

- OK >> GO TO 6.
- NG >> GO TO 9.

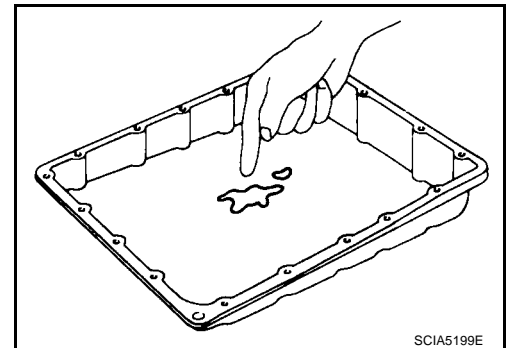

6. DETECT MALFUNCTIONING ITEM

- Check the malfunction items. If any items are damaged, repair or replace damaged parts. Refer to [AT-63, "Symptom Chart"](#) (Symptom No.58).

OK or NG

- OK >> GO TO 7.
- NG >> Repair or replace damaged parts.

7. CHECK SYMPTOM

Check again. Refer to [AT-60, "Cruise Test - Part 3"](#) .

OK or NG

- OK >> **INSPECTION END**
- NG >> GO TO 8.

TROUBLE DIAGNOSIS FOR SYMPTOMS

8. PERFORM TCM INSPECTION

1. Perform TCM input/output signals inspection. Refer to [AT-84, "TCM Input/Output Signal Reference Values"](#) .
2. If NG, recheck A/T assembly harness connector terminals for damage or loose connection with harness connector.

OK or NG

- OK >> **INSPECTION END**
NG >> Repair or replace damaged parts.

9. DETECT MALFUNCTIONING ITEM

- Check the malfunction items. If any items are damaged, repair or replace damaged parts. Refer to [AT-63, "Symptom Chart"](#) (Symptom No.58).

OK or NG

- OK >> GO TO 7.
NG >> Repair or replace damaged parts.

A
B
AT
D
E
F
G
H
I
J
K
L
M

SHIFT CONTROL SYSTEM

SHIFT CONTROL SYSTEM

PPF:34901

Control Device Removal and Installation

ECS00B32

Floor shift models

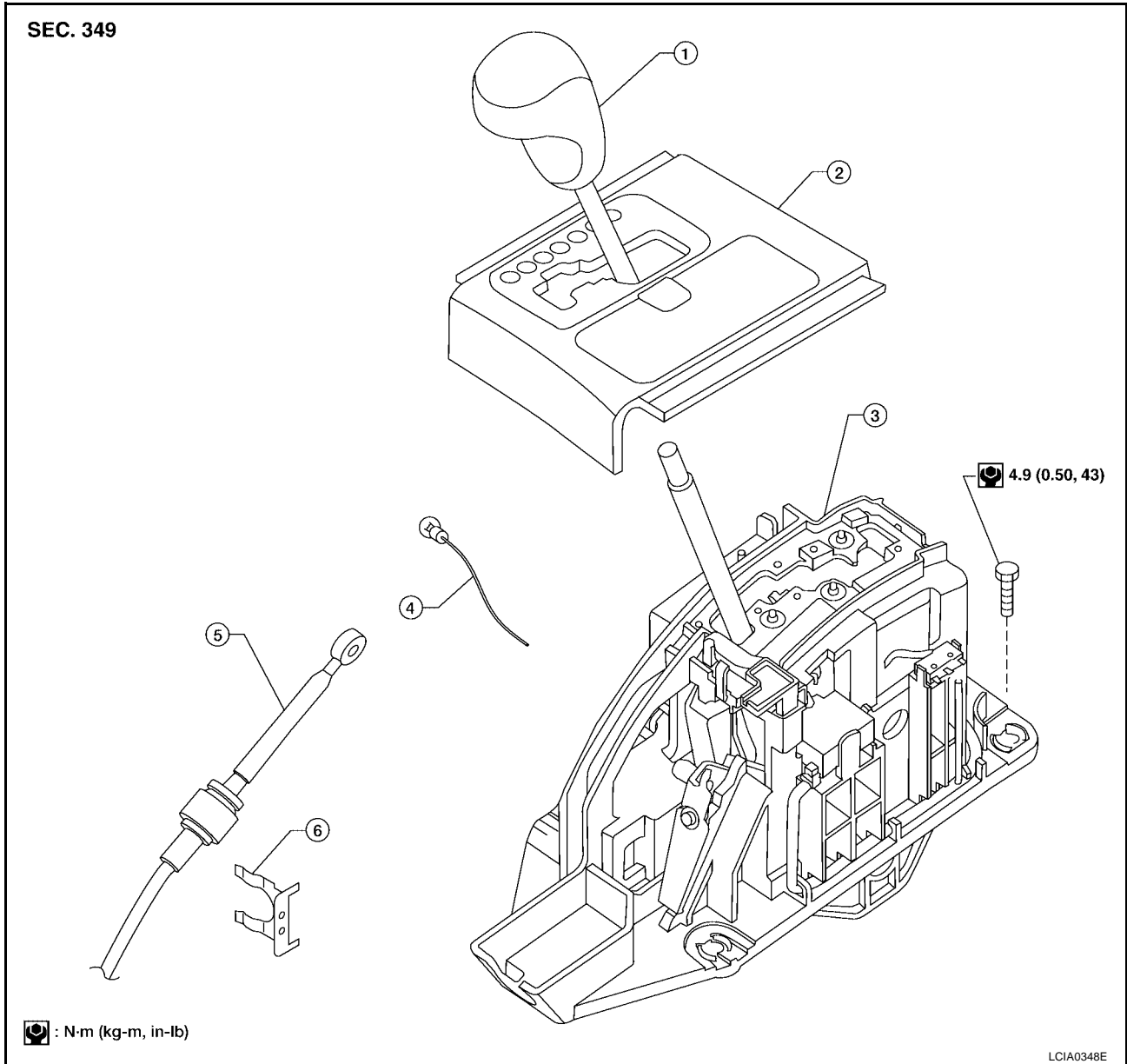

1. Selector lever knob

2. A/T console finisher

3. Control device assembly

4. Position lamp

5. A/T selector control cable

6. Lock plate

SHIFT CONTROL SYSTEM

Column shift models

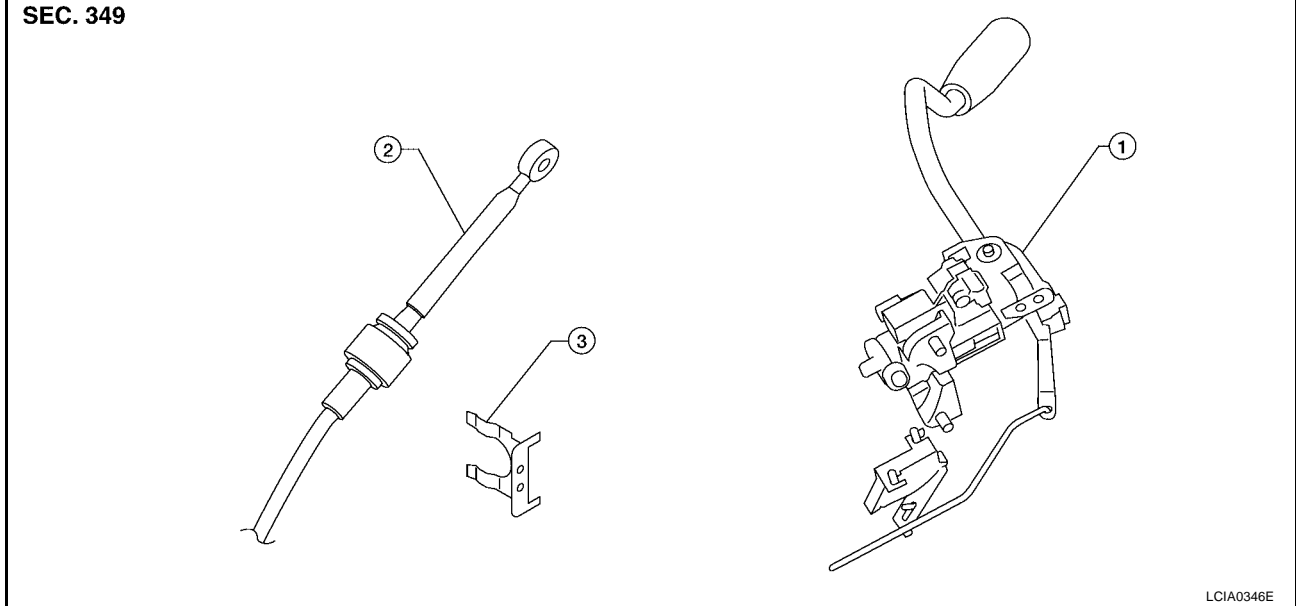

1. Column shift control

2. Shift cable

3. A/T cable lock plate clip

REMOVAL

Floor shift

1. Remove A/T finisher. Refer to [IP-13, "A/T FINISHER"](#) .
2. Disconnect A/T device harness connector.
3. Disconnect selector control cable.
4. Remove control device assembly.

Column shift

1. Remove the column shift control. Refer to [PS-9, "STEERING COLUMN"](#) .
2. Remove the A/T cable clip lock plate and remove the cable from column shifter pin.

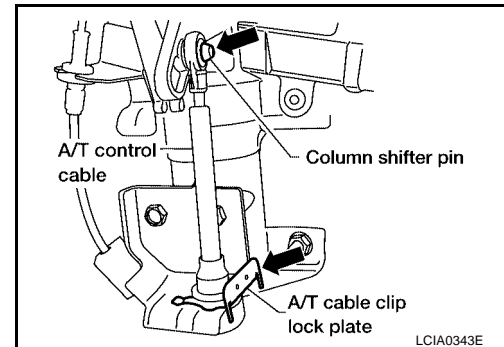

INSTALLATION

Installation is in reverse order of removal.

- After installation is completed, be sure to check A/T position, refer to [AT-238, "Checking of A/T Position"](#) and adjust if necessary, refer to [AT-238, "Adjustment of A/T Position"](#) .

A
B
AT
D
E
F
G
H
I
J
K
L
M

SHIFT CONTROL SYSTEM

Adjustment of A/T Position

ECS00B33

1. Loosen nut of control cable.
2. Place PNP switch and selector lever in "P" position.
3. After pushing the control cable in the direction shown with a force of 9.8 N·m (1kg-m, 2.2 lb-ft), release it. This is in the natural state, tighten control cable nut to specifications.

Control cable nut : 14.5 N·m (1.5 kg-m, 11 ft-lb)

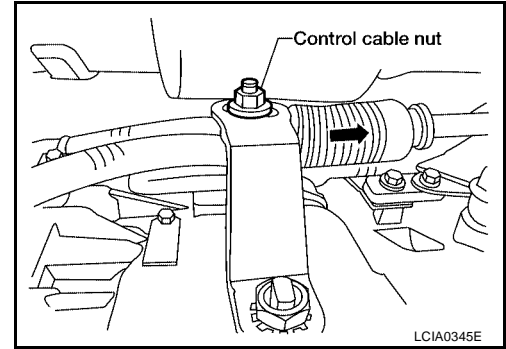

Checking of A/T Position

ECS00B34

NOTE:

Following procedure will cover both column and floor shift selector levers.

1. Place selector lever in "P" position, and turn ignition switch ON (engine stop).
2. Make sure selector lever can be shifted to other than "P" position when brake pedal is depressed. Also make sure selector lever can be shifted from "P" position only when brake pedal is depressed.
3. Move the selector lever and check for excessive effort, sticking, noise or rattle.
4. Confirm the selector lever stops at each position with the feel of engagement when it is moved through all the positions. Check whether or not the actual position the selector lever is in matches the position shown by the shift position indicator and the transmission body.
5. The method of operating the lever to individual positions correctly should be as shown in the figure.
6. Confirm the back-up lamps illuminate only when lever is placed in the "R" position. Confirm the back-up lamps does not illuminate when selector lever is pushed against "R" position in the "P" or "N" position.
7. Confirm the engine can only be started with the selector lever in the "P" and "N" positions.
8. Make sure transmission is locked completely in "P" position.

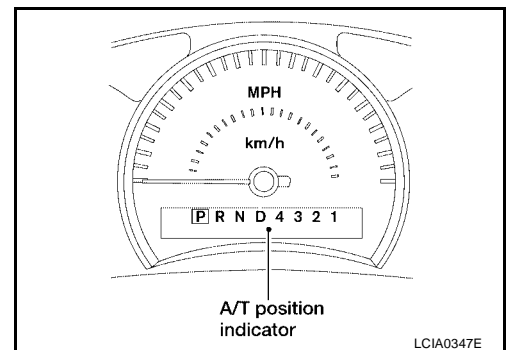
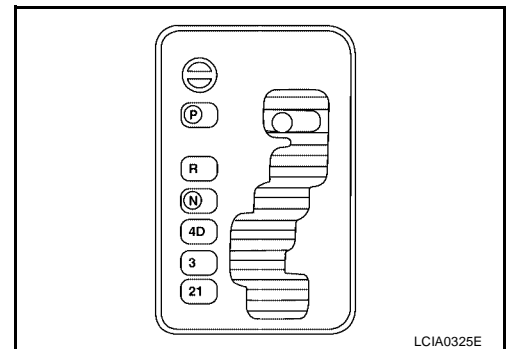

A/T SHIFT LOCK SYSTEM

A/T SHIFT LOCK SYSTEM

PF3:34950

Description FLOOR SHIFT

ECS00B35

- The electrical key interlock mechanism also operates as a shift lock:
With the ignition switch turned to ON, the selector lever cannot be shifted from "P" (parking) to any other position unless the brake pedal is depressed.
With the key removed, the selector lever cannot be shifted from "P" to any other position.
The key cannot be removed unless the selector lever is placed in "P".
- The shift lock and key interlock mechanisms are controlled by the ON-OFF operation of the shift lock solenoid and by the operation of the rotator and slider located inside the key cylinder, respectively.

COLUMN SHIFT

- The mechanical key interlock mechanism also operates as a shift lock:
With the ignition switch turned to ON, the selector lever cannot be shifted from "P" (parking) to any other position unless the brake pedal is depressed.
With the key removed, the selector lever cannot be shifted from "P" to any other position.
The key cannot be removed unless the selector lever is placed in "P".
- The shift lock and key interlock mechanisms are controlled by the ON-OFF operation of the shift lock solenoid and by the operation of the rotator and slider located inside the key cylinder.

Shift Lock System Electrical Parts Location FLOOR SHIFT

ECS00B36

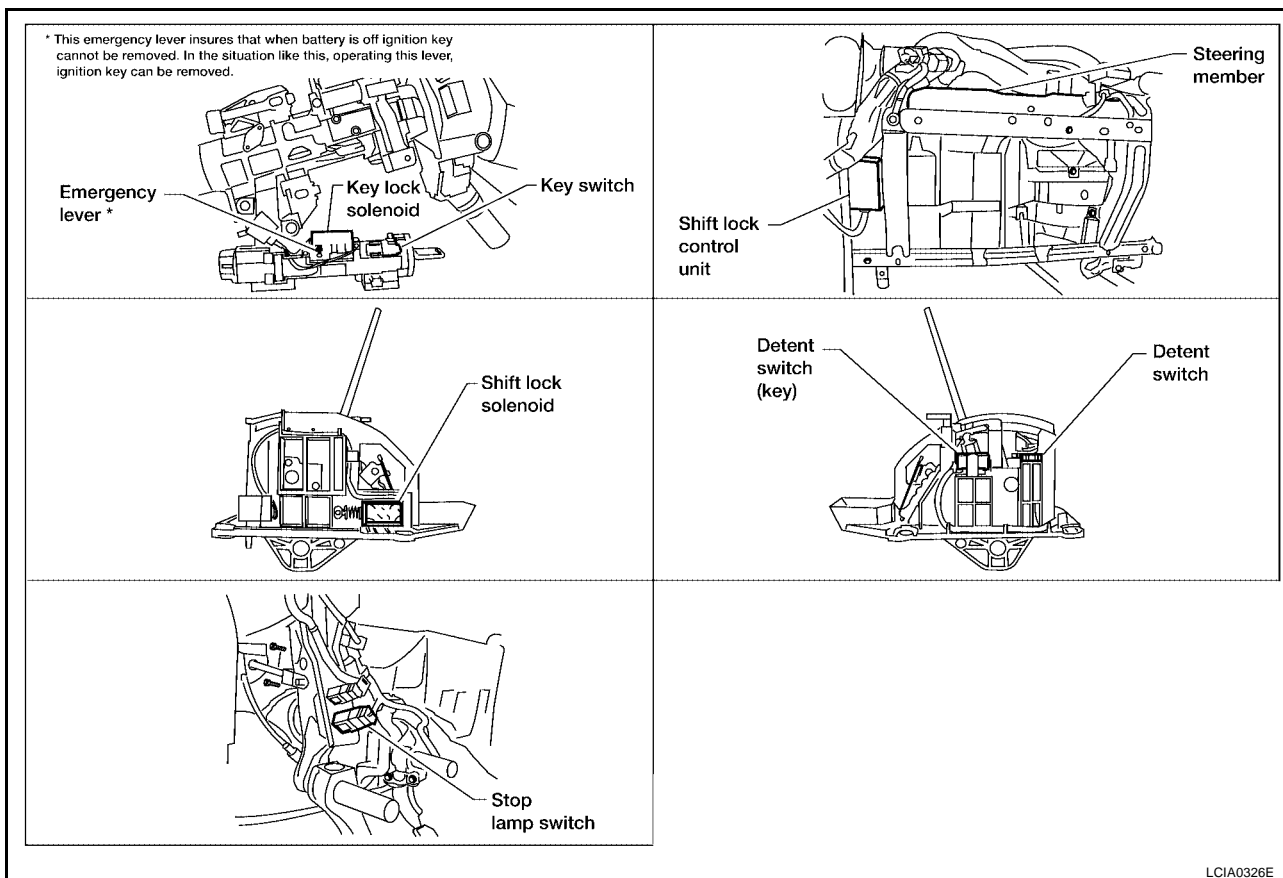

A/T SHIFT LOCK SYSTEM

COLUMN SHIFT

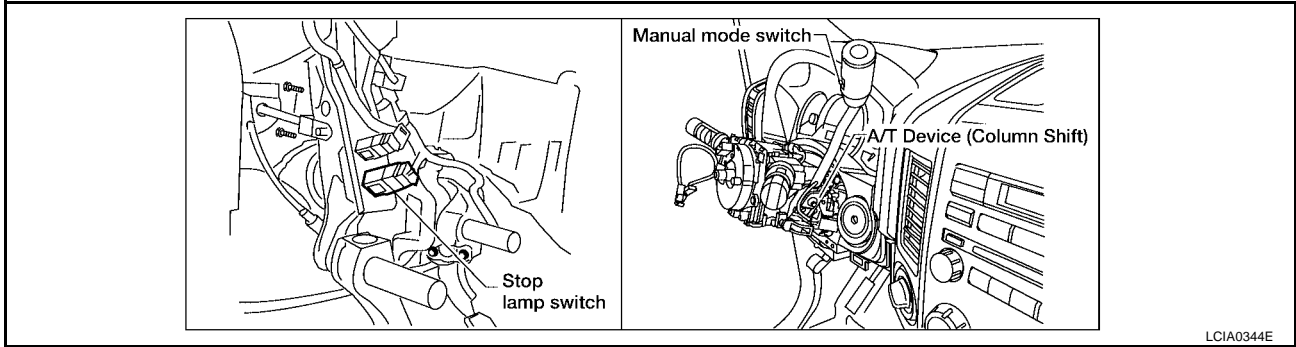

A/T SHIFT LOCK SYSTEM

Wiring Diagram — A/T — SHIFT FLOOR SHIFT

ECS00B37

AT-SHIFT-01

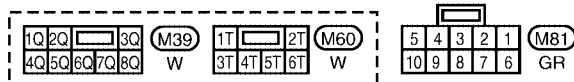
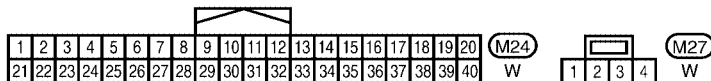
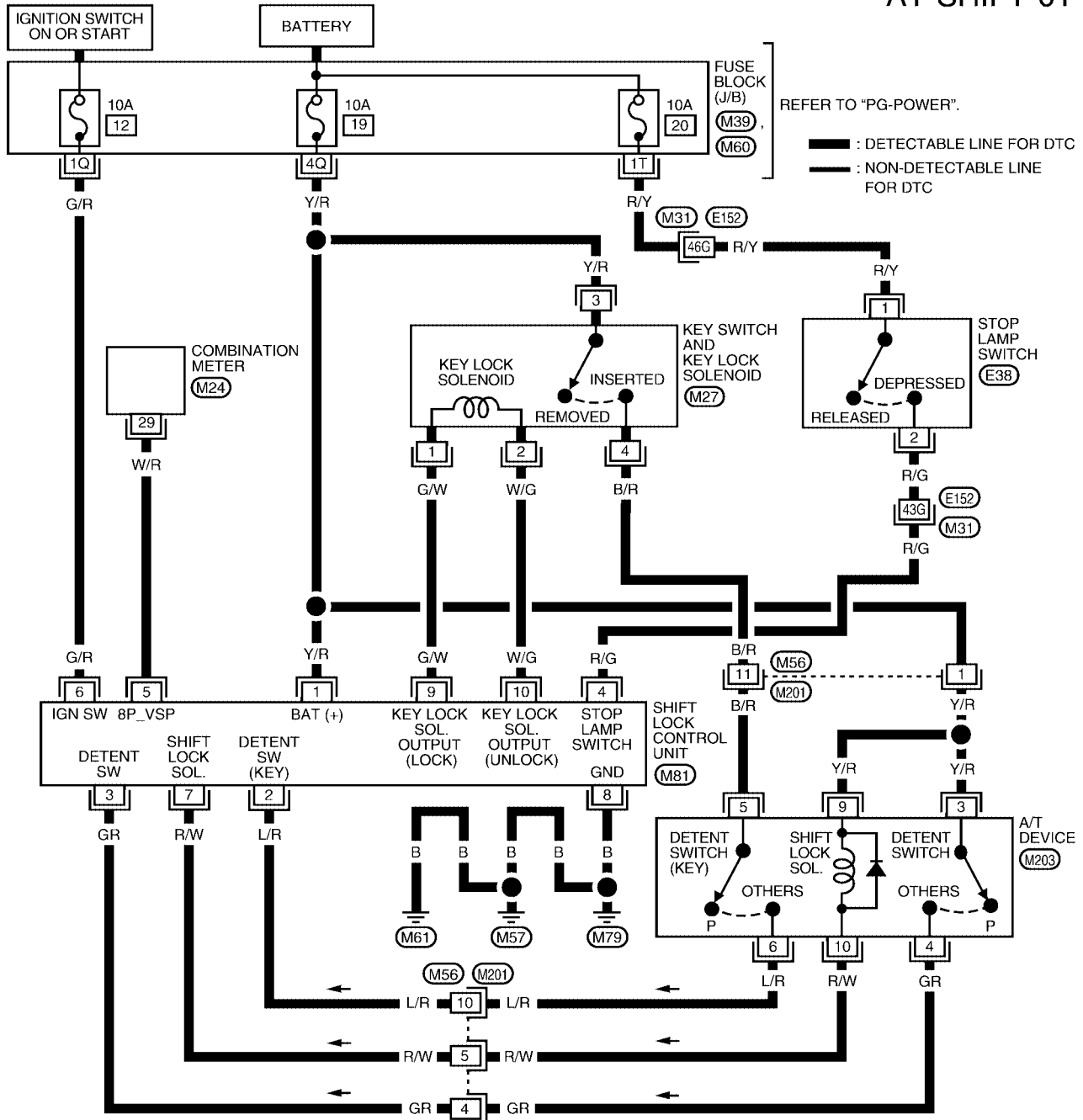

REFER TO THE FOLLOWING.

(M31) - SUPER MULTIPLE JUNCTION (SMJ)

BCWA0337E

A/T SHIFT LOCK SYSTEM

COLUMN SHIFT

AT-SHIFT-02

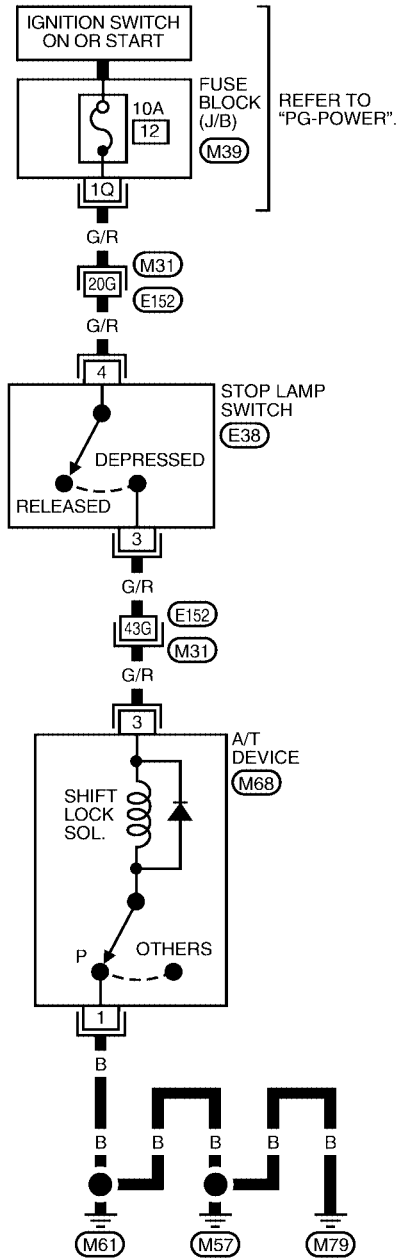

: DETECTABLE LINE FOR DTC
 : NON-DETECTABLE LINE FOR DTC

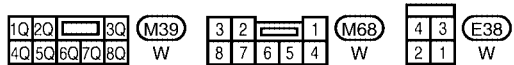

REFER TO THE FOLLOWING.

(M31) - SUPER MULTIPLE JUNCTION (SMJ)

A/T SHIFT LOCK SYSTEM

Shift Lock Control Unit Reference Values SHIFT LOCK HARNESS CONNECTOR TERMINALS LAYOUT

ECS00B38

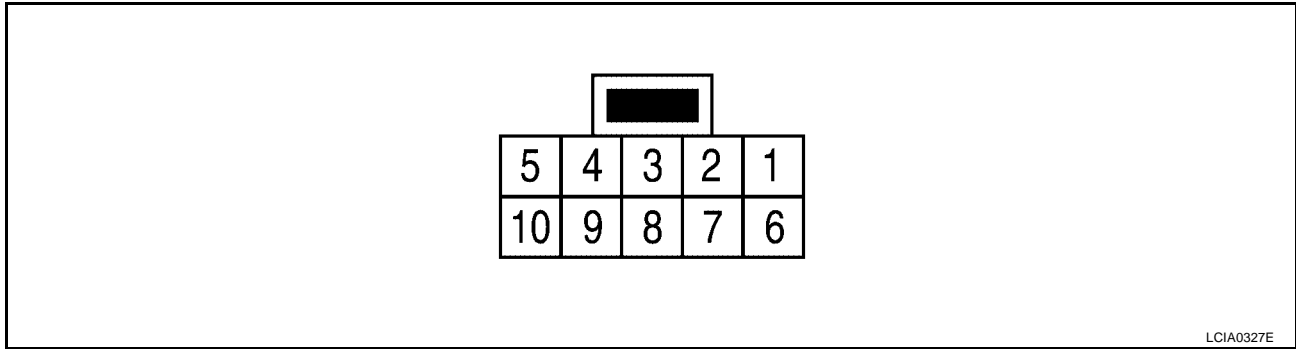

SHIFT LOCK CONTROL UNIT INSPECTION TABLE

Data are reference values.

TERMINAL NO.	WIRE COLOR	ITEM	CONDITION	VOLTAGE (V)
1	Y/R	Power source	Ignition switch: "ON"	Battery voltage
			Ignition switch: "OFF"	Battery voltage
2	L/R	Detention switch (for key)	When selector lever is not in "P" position with key inserted.	Battery voltage
			Except the above	Approx. 0V
3	GR	Detention switch (for shift)	When selector lever is not in "P" position	Battery voltage
			Except the above	Approx. 0V
4	R/G	Stop lamp switch	When brake pedal is depressed	Battery voltage
			When brake pedal is released	Approx. 0V
5	W/R	Vehicle speed signal	—	—
			—	—
6	G/R	Ignition signal	Ignition switch: "OFF"	Approx. 0V
			Ignition switch: "ON"	Battery voltage
7	R/W	Shift lock solenoid	When brake pedal is depressed with ignition switch "ON".	Approx. 0V
			When brake pedal is depressed.	Battery voltage
8	B	Ground	Always	Approx. 0V
9	G/W	Key lock solenoid	When the selector lever is set to a position other than the "P" position, and the key switch is turned from "ON" to "OFF"	Battery voltage for approx. 0.1 sec. (Note)
			Except the above	Approx. 0V
10	W/G	Key unlock solenoid	When ignition switch is not in "ON" position with key inserted.	Battery voltage for approx. 0.1 sec. (Note)
			Except the above	Approx. 0V

NOTE:

Confirm that the pointer swings only momentarily because the output time is so short. If the inspection is done with an oscilloscope, it should be observed that the power source voltage lasts for 3.5 to 10 ms.

A/T SHIFT LOCK SYSTEM

ECS00B39

DIAGNOSTIC PROCEDURE

COLUMN SHIFT

SYMPTOM 1:

- Selector lever cannot be moved from “P” position with key in ON position and brake pedal applied.
- Selector lever can be moved from “P” position with key in ON position and brake pedal released.
- Selector lever can be moved from “P” position when key is removed from key cylinder.

SYMPTOM 2:

- Ignition key cannot be removed when selector lever is set to “P” position.
- Ignition key can be removed when selector lever is set to any position except “P”.

1. CHECK SELECTOR LEVER POSITION

Check the selector lever position for damage.

OK or NG

OK >> GO TO 2.

NG >> Check selector lever. Refer to [AT-238, "Adjustment of A/T Position"](#).

2. CHECK SHIFT LOCK SOLENOID AND PARK POSITION SWITCH

1. Connect A/T device harness connector.
2. Turn ignition switch “ON”.
3. Selector lever is set in “P” position.
4. Check operation sound.

Condition	Brake pedal	Operation sound
When ignition switch is turned to “ON” position and selector lever is set in “P” position.	Depressed	Yes
	Released	No

OK or NG

OK >> **INSPECTION END**

NG >> GO TO 3.

3. CHECK POWER SOURCE

1. Turn ignition switch “ON”. (Do not start engine.)
2. Selector lever is set in “P” position.
3. Check the voltage between A/T device connector M68 terminal 3 (G/R) and ground.

Condition	Brake pedal	Data (Approx.)
When ignition switch is turned to “ON” position.	Depressed	Battery voltage
	Released	0V

OK or NG

OK >> GO TO 6.

NG >> GO TO 4.

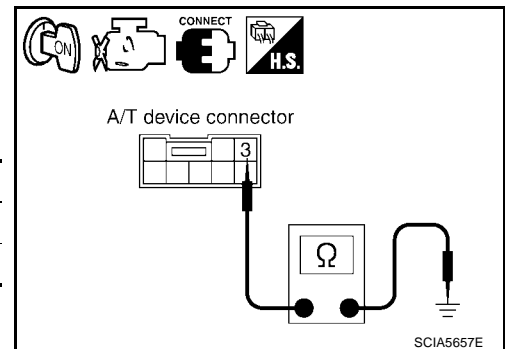

A/T SHIFT LOCK SYSTEM

4. CHECK STOP LAMP SWITCH

1. Turn ignition switch "OFF".
2. Disconnect stop lamp switch connector.
3. Check continuity between stop lamp switch connector E38 terminals 3 and 4.

Condition	Continuity
When brake pedal is depressed	Yes
When brake pedal is released	No

Check stop lamp switch after adjusting brake pedal — refer to [BR-6, "BRAKE PEDAL"](#) .

OK or NG

- OK >> GO TO 5.
- NG >> Repair or replace damaged parts.

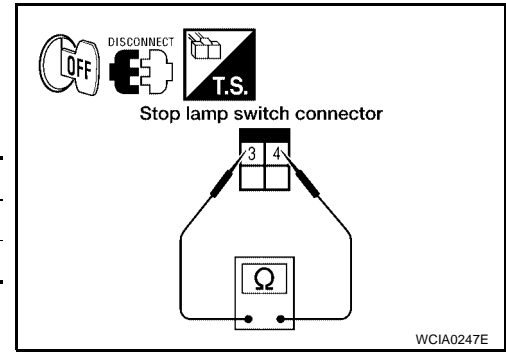

5. DETECT MALFUNCTIONING ITEM

Check the following items. If any items are damaged, repair or replace damaged parts.

- Harness for short or open between fuse block (J/B) and stop lamp switch terminal 4 (G/R)
- Harness for short or open between stop lamp switch terminal 3 (G/R) and A/T device terminal 3 (G/R).
- 10A fuse [No.12, located in the fuse block (J/B)]
- Ignition switch. Refer to [PG-4, "POWER SUPPLY ROUTING CIRCUIT"](#) .

OK or NG

- OK >> GO TO 6.
- NG >> Repair or replace damaged parts.

6. CHECK A/T DEVICE CIRCUIT

1. Turn ignition switch "OFF".
2. Disconnect A/T device connector.
3. Check continuity between A/T device connector M68 terminal 1 and terminal 3.

Condition	Continuity
Selector lever in "P" position	No
Selector lever in other position	Yes

4. Connect A/T device connector.

OK or NG

- OK >> GO TO 7.
- NG >> Replace shift lock solenoid or park position switch.

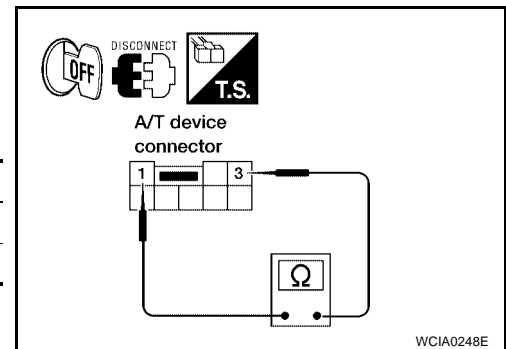

7. CHECK GROUND CIRCUIT

1. Turn ignition switch "OFF".
2. Disconnect A/T device connector.
3. Check continuity between A/T device connector M68 terminal 1 (B) and ground.

Continuity should exist.

OK or NG

- OK >> Replace shift lock solenoid or park position switch.
- NG >> Repair open circuit or short to power in harness or connectors.

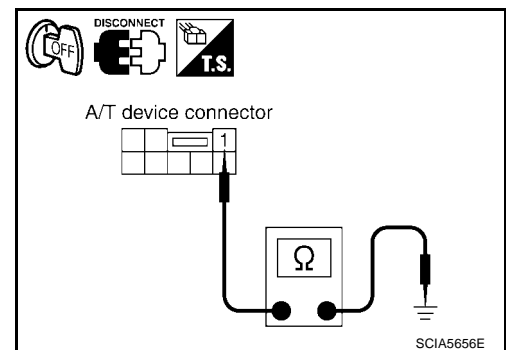

A/T SHIFT LOCK SYSTEM

ECS00B3A

Component Inspection

FLOOR SHIFT

Shift Lock Solenoid

- Check operation by applying battery voltage to the A/T device.

CAUTION:

Be sure to apply the voltage of the correct polarity to the respective terminals. Otherwise, the part may be damaged.

Connector No.	Terminal No.
M203	9 (Battery voltage) - 10 (Ground)

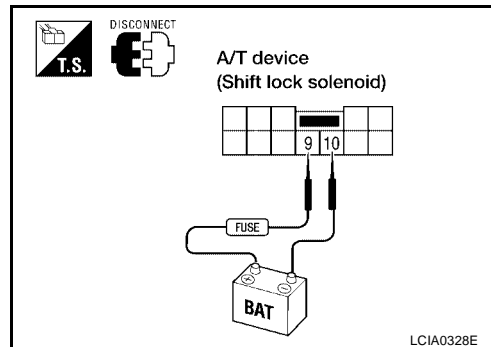

DETENTION SWITCH

For Key

- Check continuity between terminals of the A/T device.

Condition	Connector No.	Terminal No.	Continuity
When selector lever is "P" position.	M203	5 - 6	No
When selector lever is not "P" position.			Yes

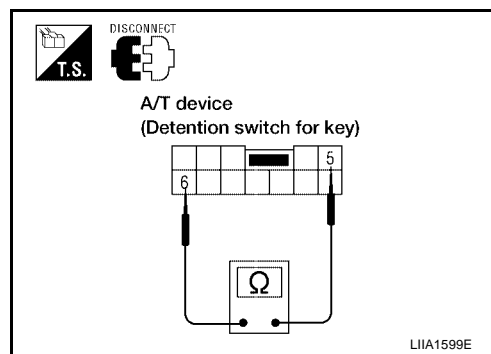

For Shift

- Check continuity between terminals of the A/T device.

Condition	Connector No.	Terminal No.	Continuity
When selector lever is "P" position.	M203	3 - 4	No
When selector lever is not "P" position.			Yes

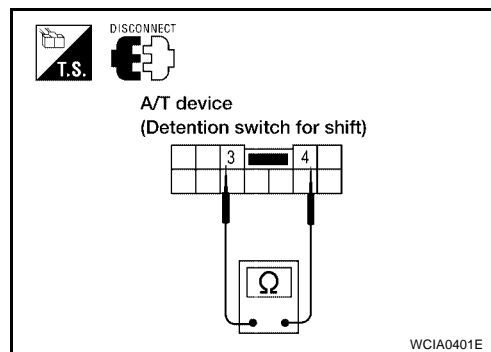

KEY LOCK SOLENOID

Key Lock

- Check operation by applying battery voltage to key switch and key lock solenoid.

CAUTION:

Be careful not to cause burnout of the harness.

Connector No.	Terminal No. (Wire color)
M80	1 (O) (Battery voltage) - 2 (B) (Ground)

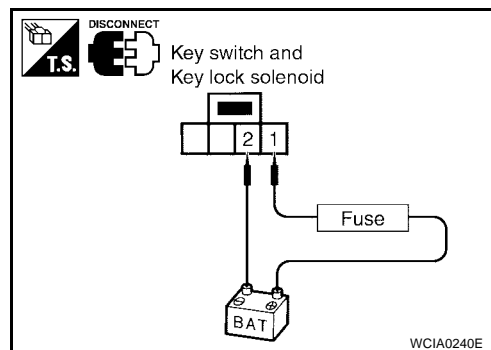

A/T SHIFT LOCK SYSTEM

Key Unlock

- Check operation by applying battery voltage to key switch and key lock solenoid.

CAUTION:

Be careful not to cause burnout of the harness.

Connector No.	Terminal No. (Wire color)
M80	2 (B) (Battery voltage) - 1 (O) (Ground)

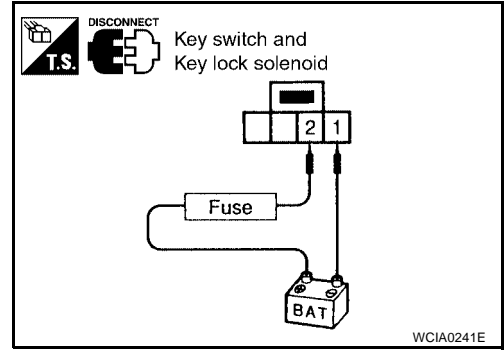

KEY SWITCH

- Check continuity between terminals of the key switch and key lock solenoid.

Condition	Connector No.	Terminal No. (Wire color)	Continuity
Key inserted	M80	3 (R/L) - 4 (R/L)	Yes
Key withdrawn			No

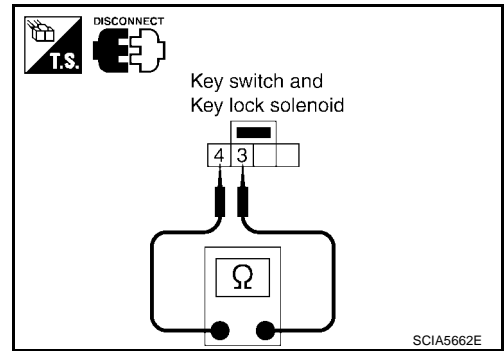

STOP LAMP SWITCH

- Check continuity between terminals of the stop lamp switch.

Condition	Connector No.	Terminal No. (Wire color)	Continuity
When brake pedal is depressed	E38	1 (R/Y) - 2 (R/G)	Yes
When brake pedal is released			No

Check stop lamp switch after adjusting brake pedal.

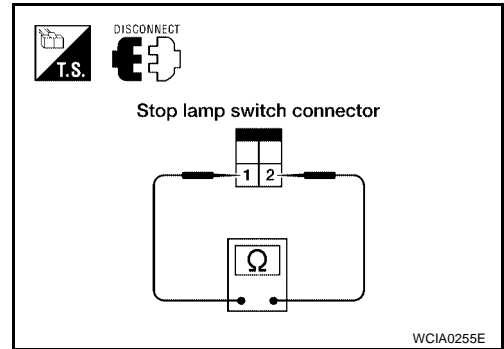

A
B
AT
D
E
F
G
H
I
J
K
L
M

KEY INTERLOCK CABLE

PPF:34908

KEY INTERLOCK CABLE

Components

ECS00B3B

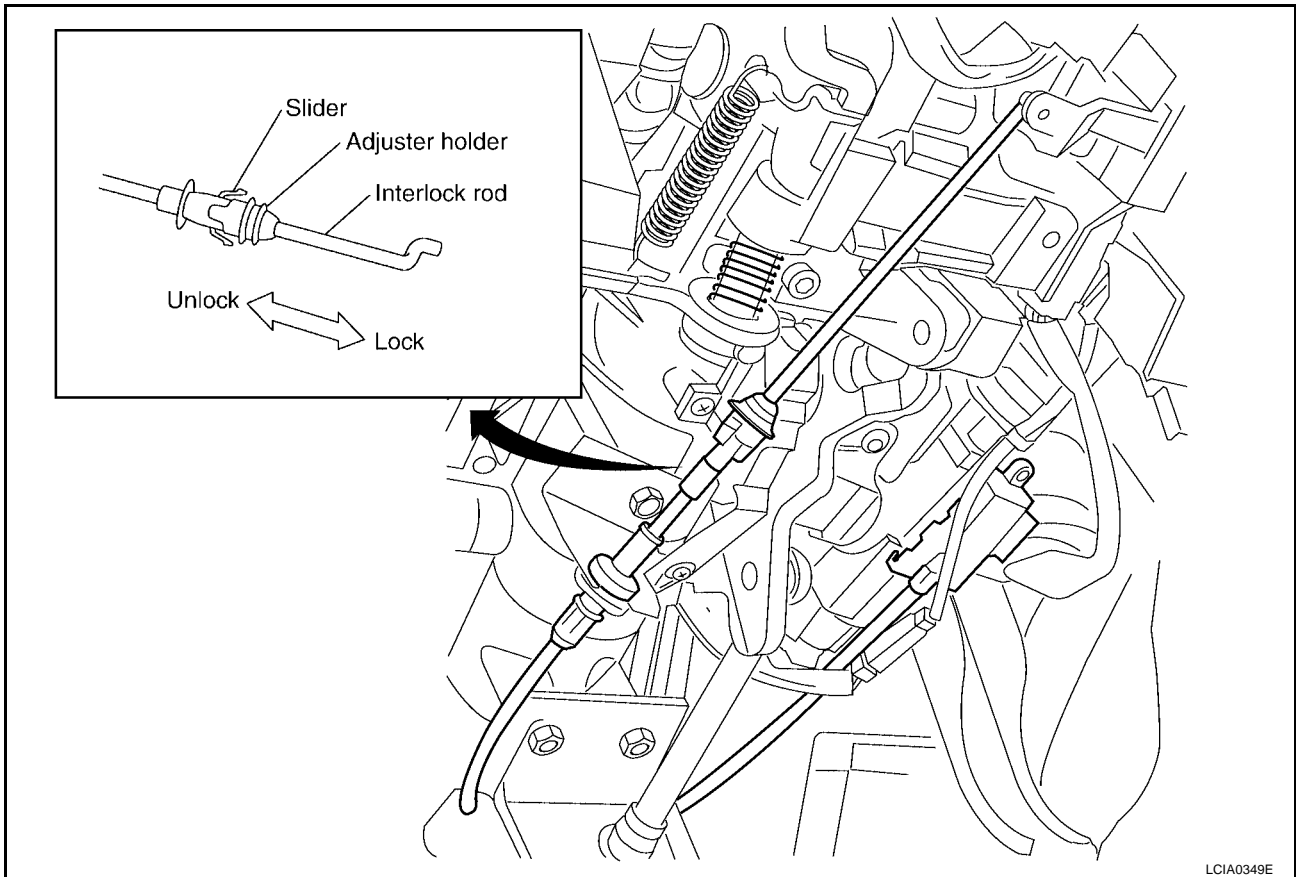

CAUTION:

- Install key interlock cable in such a way that it will not be damaged by sharp bends, twists or interference with adjacent parts.
- After installing key interlock cable to control device, make sure that casing cap and bracket are firmly secured in their positions. If casing cap can be removed with an external load of less than 39.2 N (4.0 kg, 8.8 lb), replace key interlock cable with new one.

Removal

ECS00B3C

1. Unlock slider from adjuster holder and remove rod from cable.

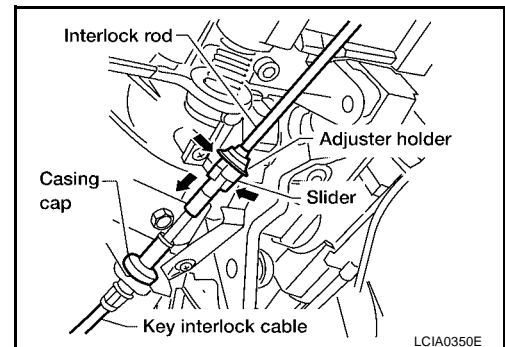

KEY INTERLOCK CABLE

2. Remove casing cap from bracket.

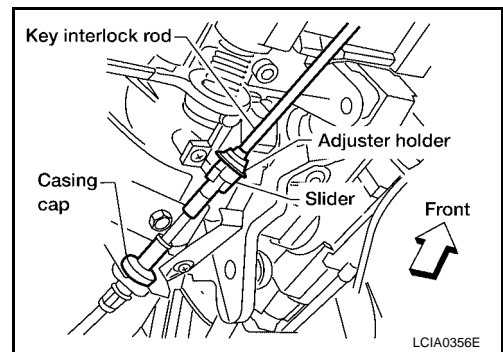

3. Disconnect the holder from the key cylinder and remove the key interlock cable.

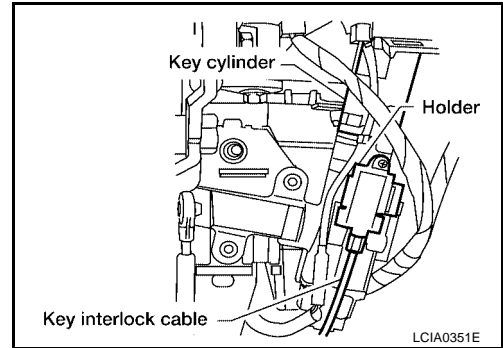

Installation

1. Set key interlock cable to key cylinder and install holder.
2. Set selector lever to P position.
3. Turn key to lock position.

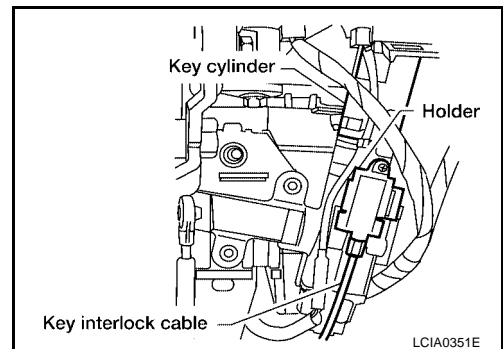

4. Insert key interlock rod into adjuster holder.
5. Install casing cap to bracket.
6. Move slider in order to lock adjuster holder to interlock rod.

CAUTION:

- Install key interlock cable in such a way that it will not be damaged by sharp bends, twists or interference with adjacent parts.
- After installing key interlock cable to control device, make sure that casing cap and bracket are firmly secured in their positions. If casing cap can be removed with an external load of less than 39.2 N (4.0 kg, 8.8 lb), replace key interlock cable with new one.

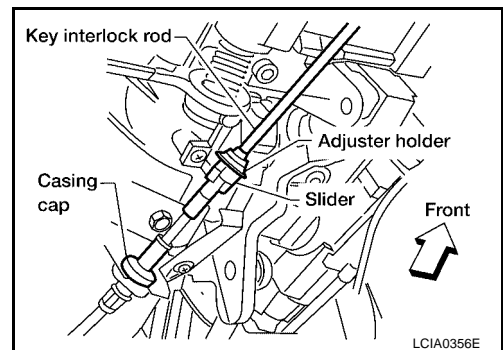

ON-VEHICLE SERVICE

Control Valve With TCM and A/T Fluid Temperature Sensor 2 COMPONENTS

ECS00B3E

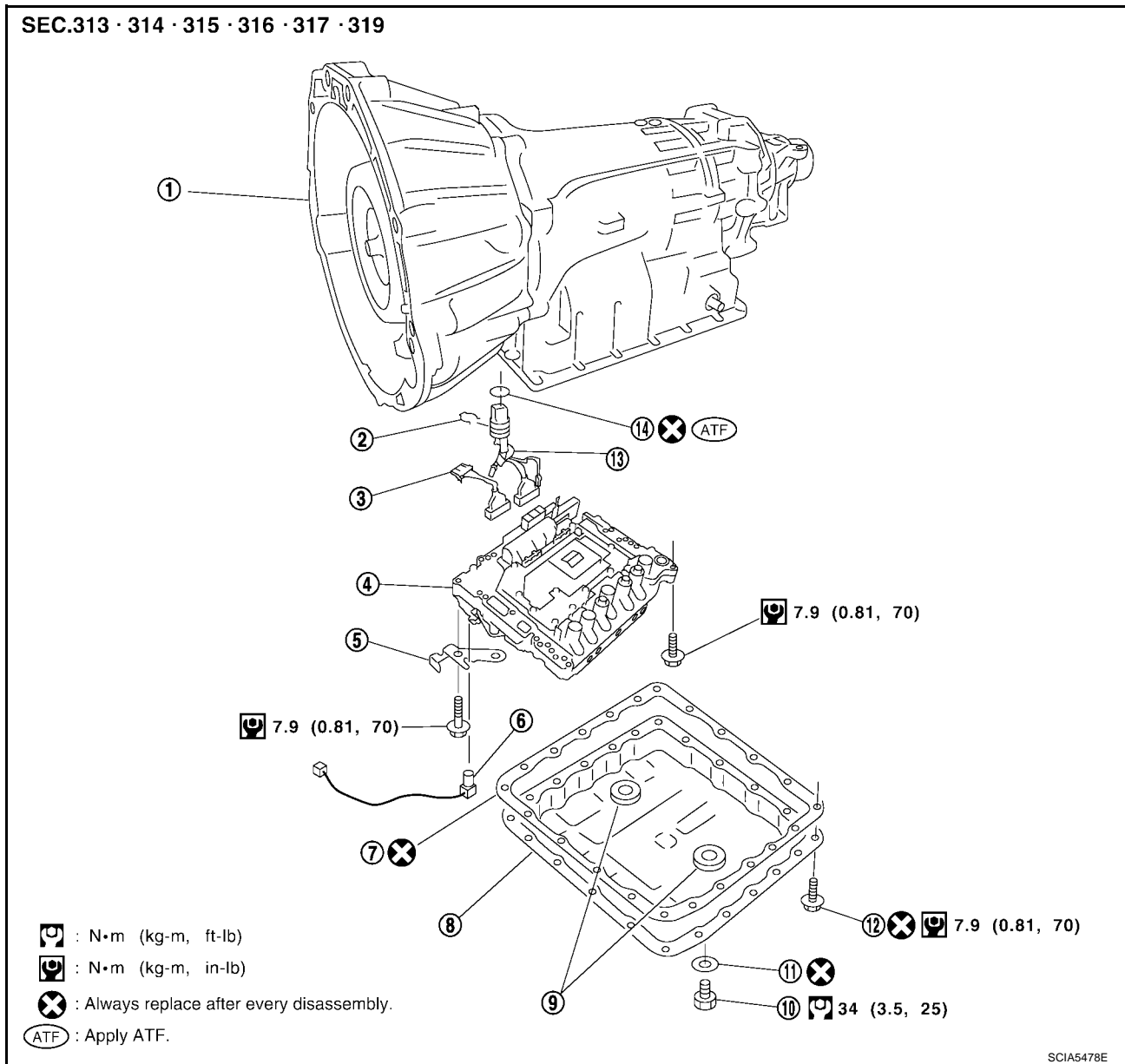

SCIA5478E

- | | | |
|----------------------------|-----------------------|-----------------------------------|
| 1. Transmission | 2. Snap ring | 3. Sub-harness |
| 4. Control valve with TCM | 5. Bracket | 6. A/T fluid temperature sensor 2 |
| 7. Oil pan gasket | 8. Oil pan | 9. Magnet |
| 10. Drain plug | 11. Drain plug gasket | 12. Oil pan bolt |
| 13. Terminal cord assembly | 14. O-ring | |

CONTROL VALVE WITH TCM REMOVAL AND INSTALLATION

Removal

1. Disconnect battery negative cable from battery negative terminal.
2. Drain ATF through drain plug.
3. Disconnect A/T assembly harness connector.

ON-VEHICLE SERVICE

4. Remove snap ring from A/T assembly harness connector.

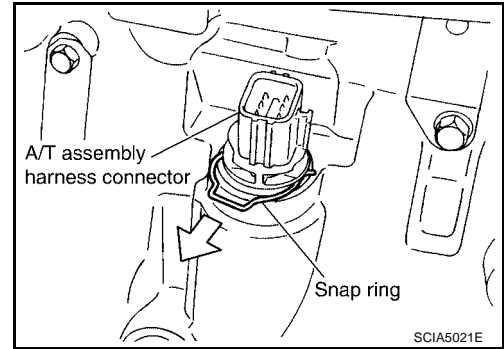

5. Push A/T assembly harness connector.

CAUTION:
Be careful not to damage connector.

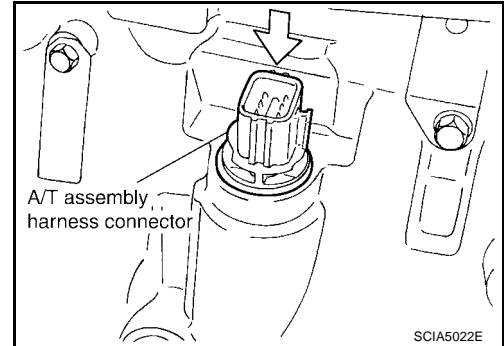

6. Remove oil pan and oil pan gasket.

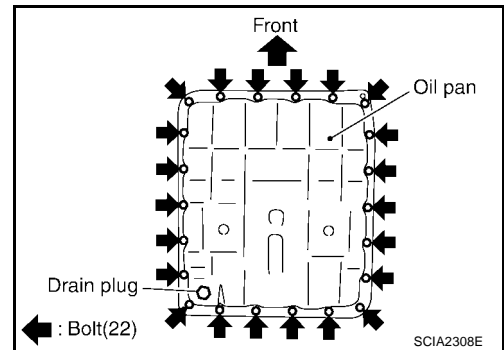

7. Check foreign materials in oil pan to help determine causes of malfunction. If the A/T fluid is very dark, smells burned, or contains foreign particles, frictional material (clutches, band) may need replacement. A tacky film that will not wipe clean indicates varnish build up. Varnish can cause valves, servo, and clutches to stick and can inhibit pump pressure.

● If frictional material is detected, perform A/T fluid cooler cleaning. Refer to [AT-12, "A/T Fluid Cooler Cleaning"](#).

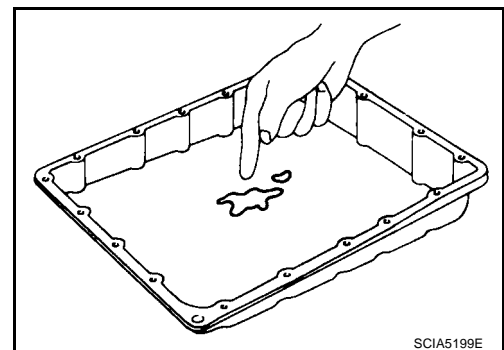

8. Remove magnets from oil pan.

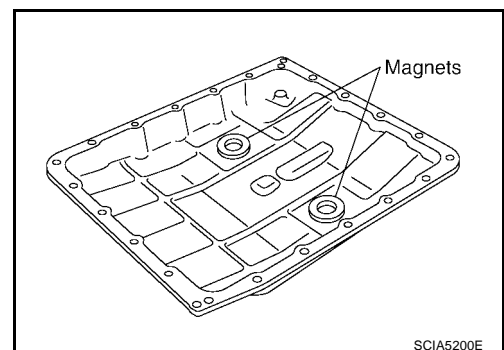

A
B
AT
D
E
F
G
H
I
J
K
L
M

ON-VEHICLE SERVICE

9. Disconnect A/T fluid temperature sensor 2 connector.

CAUTION:
Be careful not to damage connector.

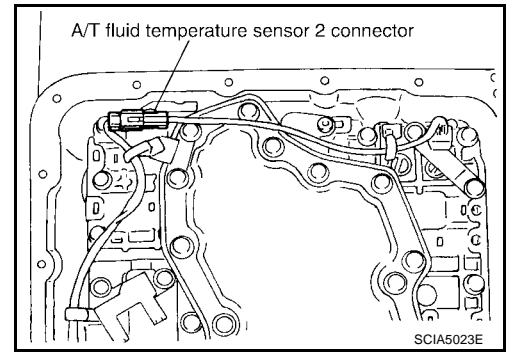

10. Straighten terminal clips to free terminal cord assembly and A/T fluid temperature sensor 2 harness.

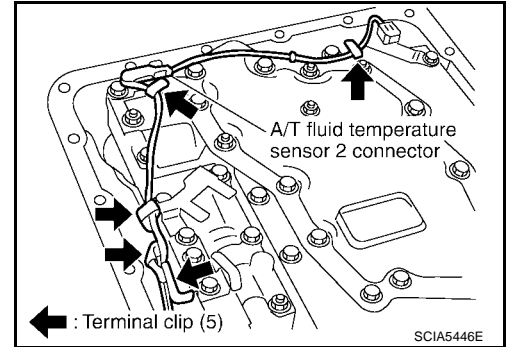

11. Disconnect revolution sensor connector.

CAUTION:
Be careful not to damage connector.

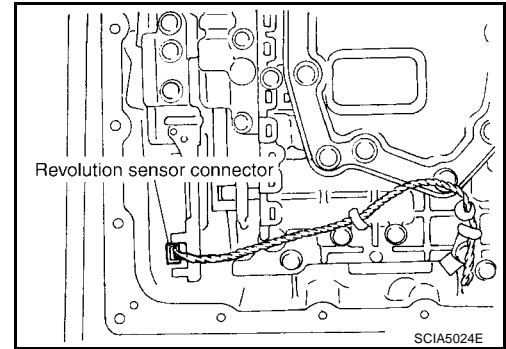

12. Straighten terminal clips to free revolution sensor harness.

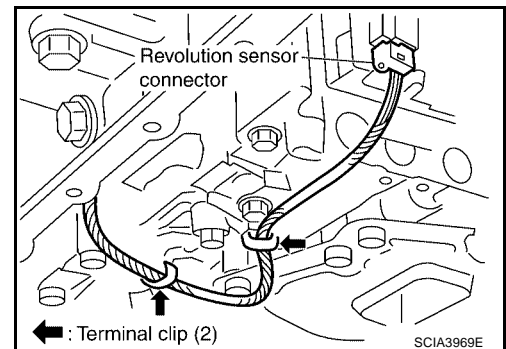

13. Remove bolts A, B and C from control valve with TCM.

Bolt symbol	Length mm (in)	Number of bolts
A	42 (1.65)	5
B	55 (2.17)	6
C	40 (1.57)	1

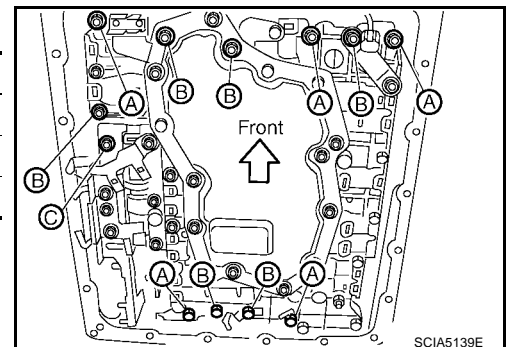

ON-VEHICLE SERVICE

14. Remove control valve with TCM from transmission case.

CAUTION:

When removing, be careful with the manual valve notch and manual plate height. Remove it vertically.

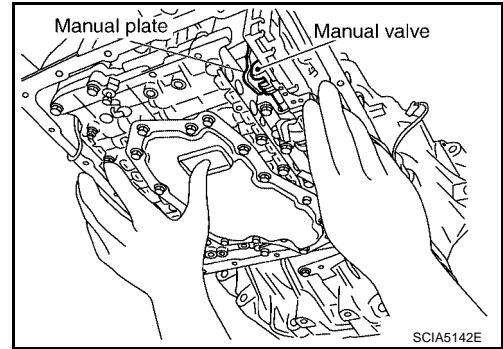

15. Remove A/T fluid temperature sensor 2 with bracket from control valve with TCM.

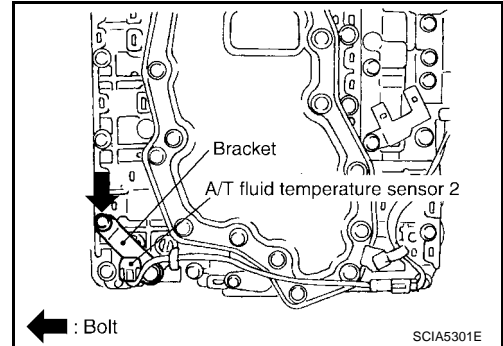

16. Remove bracket from A/T fluid temperature sensor 2.

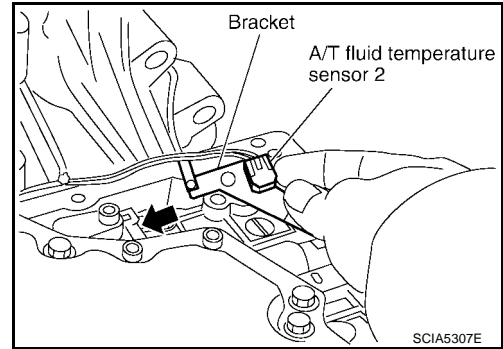

17. Remove O-ring from A/T assembly harness connector.

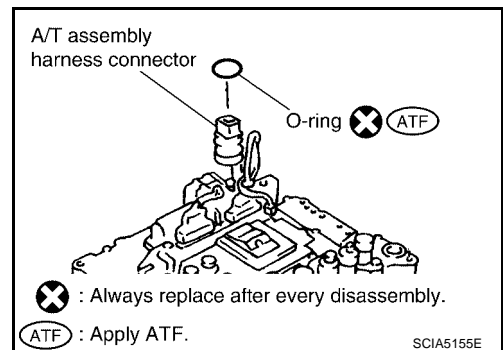

18. Disconnect TCM connectors.

CAUTION:

Be careful not to damage connectors.

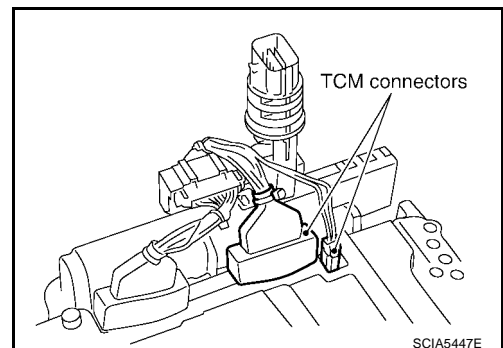

A

B

AT

D

E

F

G

H

I

J

K

L

M

ON-VEHICLE SERVICE

19. Remove A/T assembly harness connector from control valve with TCM using a flat-bladed screwdriver.

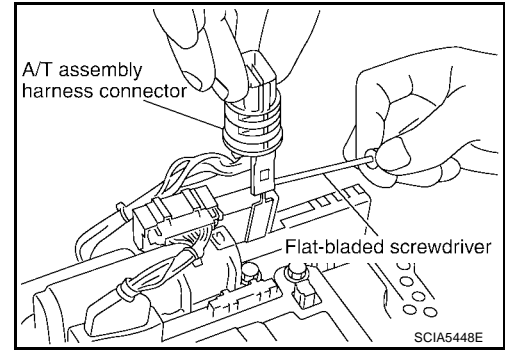

20. Disconnect TCM connector and park/neutral position switch connector.

CAUTION:

Be careful not to damage connector.

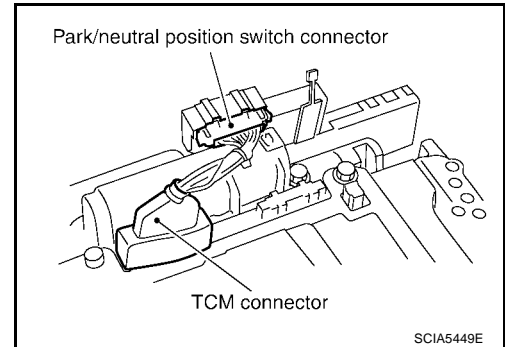

Installation

CAUTION:

After completing installation, check A/T fluid leakage and fluid level. Refer to [MA-23, "Changing A/T Fluid"](#) and [MA-21, "Checking A/T Fluid"](#).

1. Connect TCM connector and park/neutral position switch connector.

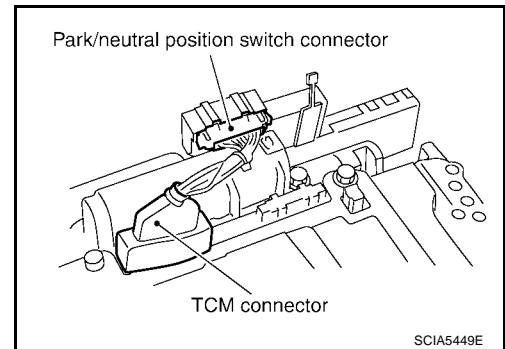

2. Install A/T assembly harness connector to control valve with TCM.

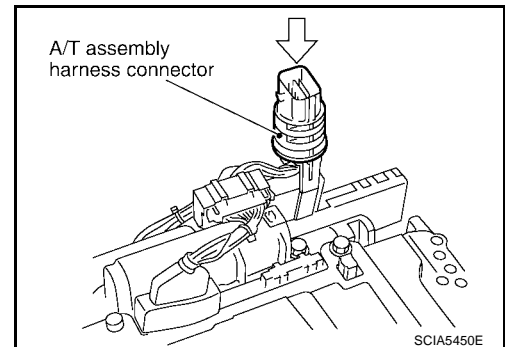

ON-VEHICLE SERVICE

3. Connect TCM connectors.

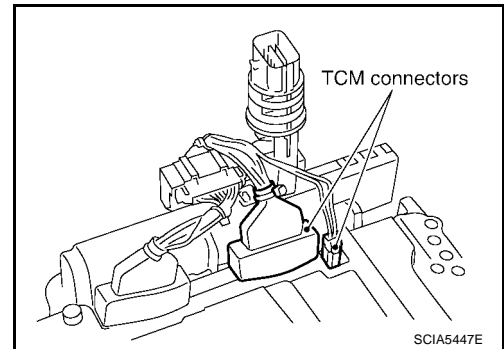

4. Install new O-ring in A/T assembly harness connector.

CAUTION:

- Do not reuse O-ring.
- Apply ATF to O-ring.

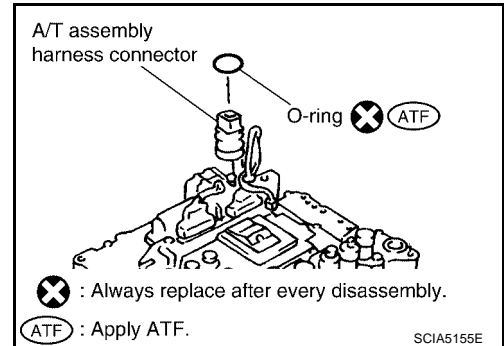

5. Install A/T fluid temperature sensor 2 to bracket.

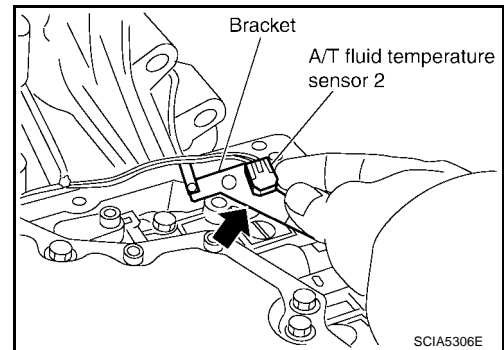

6. Install A/T fluid temperature sensor 2 (with bracket) in control valve with TCM.

CAUTION:

Adjust bolt hole of bracket to bolt hole of control valve with TCM.

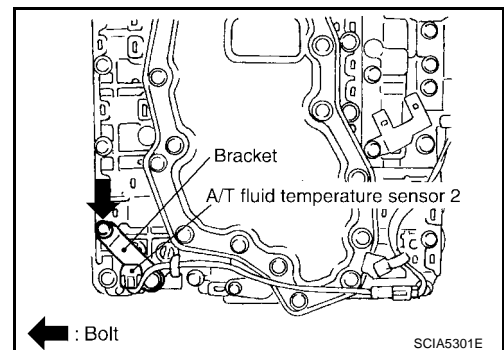

7. Install control valve with TCM in transmission case.

CAUTION:

- Make sure that turbine revolution sensor securely installs turbine revolution sensor hole.
- Hang down terminal cord assembly and revolution sensor harness toward outside so as not to disturb installation of control valve with TCM.
- Adjust A/T assembly harness connector of control valve with TCM to terminal hole of transmission case.

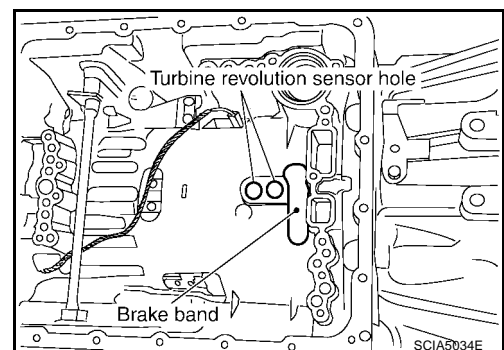

A
B
AT
D
E
F
G
H
I
J
K
L
M

ON-VEHICLE SERVICE

- Assemble it so that manual valve cutout is engaged with manual plate projection.

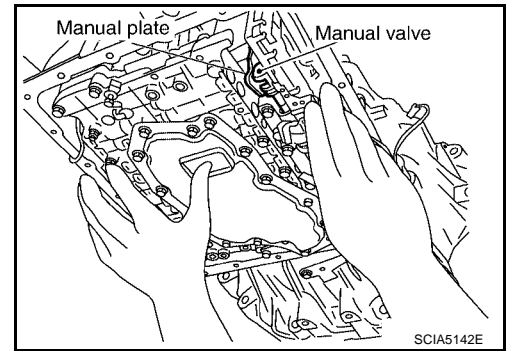

8. Install bolts A, B and C in control valve with TCM.

Bolt symbol	Length mm (in)	Number of bolts
A	42 (1.65)	5
B	55 (2.17)	6
C	40 (1.57)	1

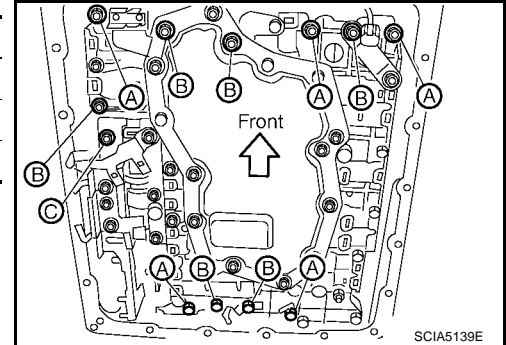

9. Tighten bolt 1, 2 and 3 temporarily to prevent dislocation. After that tighten them in order (1 → 2 → 3), and then tighten other bolts.

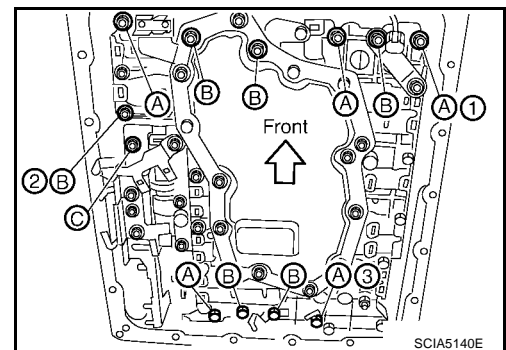

10. Connect A/T fluid temperature sensor 2 connector.

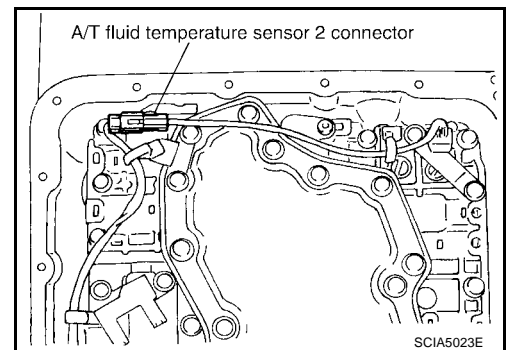

11. Securely fasten terminal cord assembly and A/T fluid temperature sensor 2 harness with terminal clips.

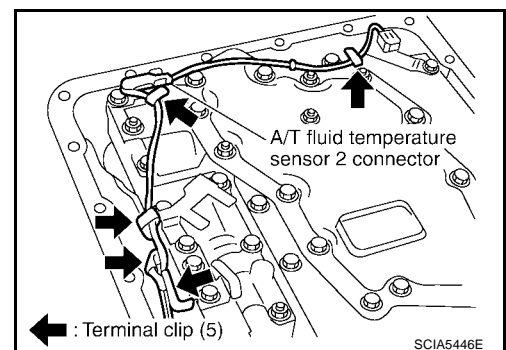

ON-VEHICLE SERVICE

12. Connect revolution sensor connector.

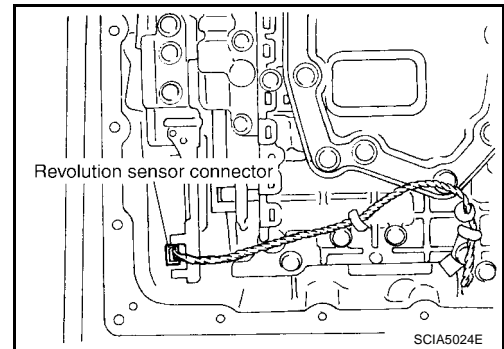

13. Securely fasten revolution sensor harness with terminal clips.

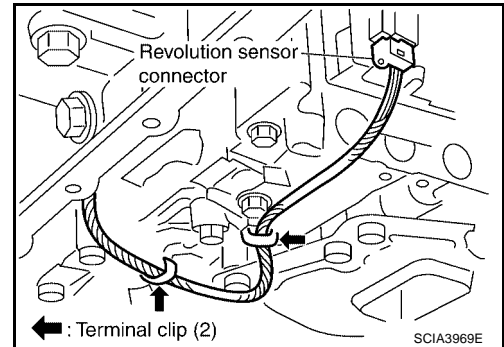

14. Install magnets in oil pan.

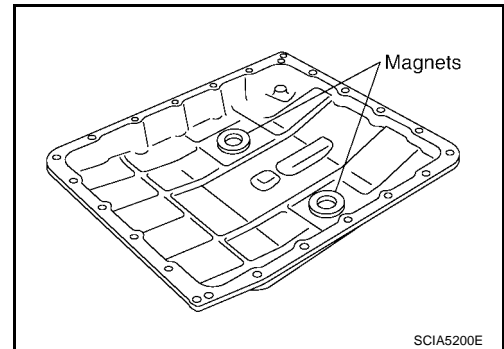

15. Install oil pan in transmission case.

a. Install new oil pan gasket in oil pan.

CAUTION:

- Do not reuse oil pan gasket.
- Install it in the direction to align hole positions.
- Complete remove all moisture, oil and old gasket, etc. from oil pan gasket mounting surfaces.

b. Install oil pan (with new oil pan gasket) in transmission case.

CAUTION:

- Install it so that drain plug comes to the position as shown.
- Be careful not to pinch harnesses.
- Complete remove all moisture, oil and old gasket, etc. from oil pan mounting surfaces.

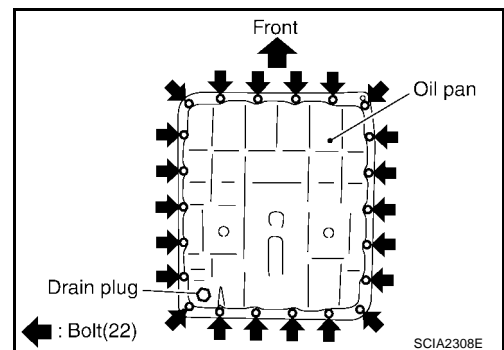

ON-VEHICLE SERVICE

- c. Tighten oil pan bolts to the specified torque in numerical order as shown after temporarily tightening them. Refer to [AT-250, "COMPONENTS"](#).

CAUTION:

Do not reuse oil pan bolts.

16. Tighten drain plug to the specified torque. Refer to [AT-250, "COMPONENTS"](#).

CAUTION:

Do not reuse drain plug gasket.

17. Pull up A/T assembly harness connector.

CAUTION:

Be careful not to damage connector.

18. Install snap ring in A/T assembly harness connector.
19. Connect A/T assembly harness connector.
20. Pour ATF into transmission assembly. Refer to [MA-23, "Changing A/T Fluid"](#).
21. Connect the negative battery terminal

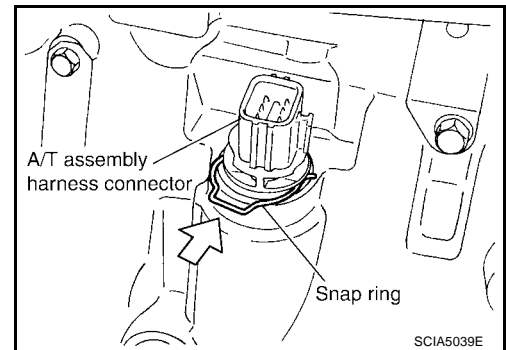
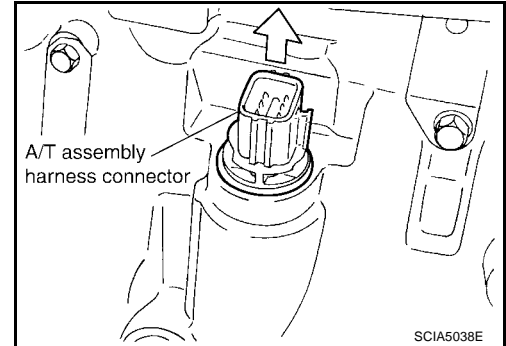
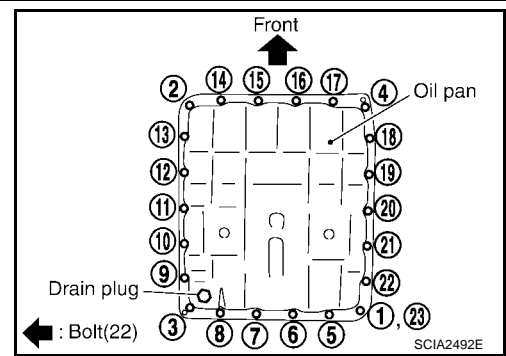

A/T FLUID TEMPERATURE SENSOR 2 REMOVAL AND INSTALLATION

Removal

1. Disconnect battery negative cable from battery negative terminal.
2. Drain ATF through drain plug.
3. Remove oil pan and oil pan gasket.

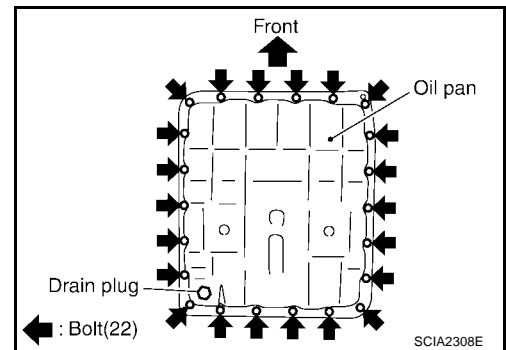

ON-VEHICLE SERVICE

4. Check foreign materials in oil pan to help determine causes of malfunction. If the A/T fluid is very dark, smells burned, or contains foreign particles, frictional material (clutches, band) may need replacement. A tacky film that will not wipe clean indicates varnish build up. Varnish can cause valves, servo, and clutches to stick and can inhibit pump pressure.

- If frictional material is detected, perform A/T fluid cooler cleaning. Refer to [AT-12, "A/T Fluid Cooler Cleaning"](#).

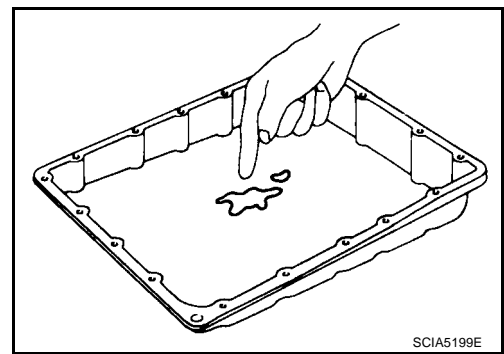

5. Disconnect A/T fluid temperature sensor 2 connector.

- CAUTION:**
Be careful not to damage connector.

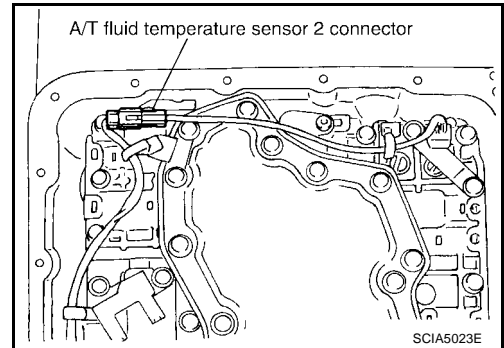

6. Straighten terminal clips to free A/T fluid temperature sensor 2 harness.

- CAUTION:**
Be careful not to damage connector.

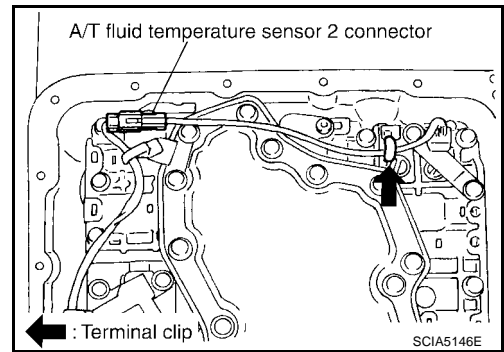

7. Remove A/T fluid temperature sensor 2 with bracket from control valve with TCM.

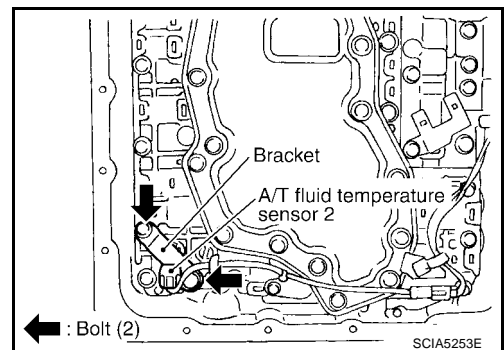

8. Remove bracket from A/T fluid temperature sensor 2.

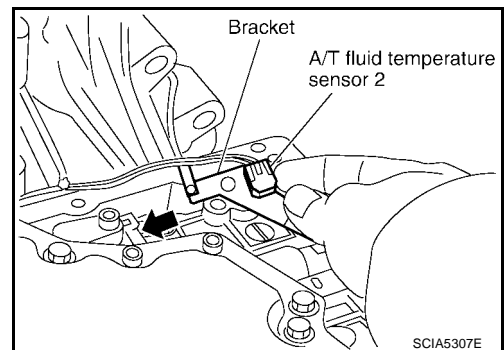

ON-VEHICLE SERVICE

Installation

CAUTION:

After completing installation, check A/T fluid leakage and fluid level. Refer to [MA-23, "Changing A/T Fluid"](#) and [MA-21, "Checking A/T Fluid"](#).

1. Install A/T fluid temperature sensor 2 in bracket.

CAUTION:

Adjust bolt hole of bracket to bolt hole of control valve with TCM.

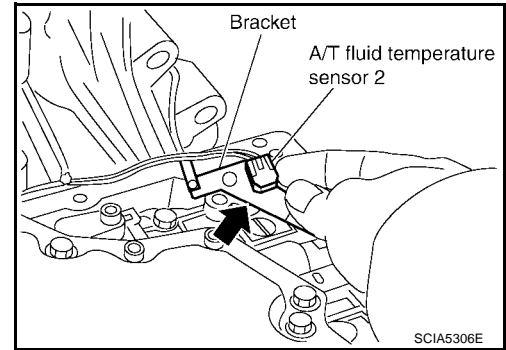

2. Install A/T fluid temperature sensor 2 in control valve with TCM. (With bracket.)

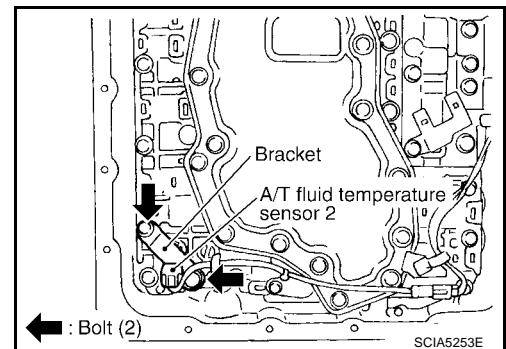

3. Connect A/T fluid temperature sensor 2 connector.

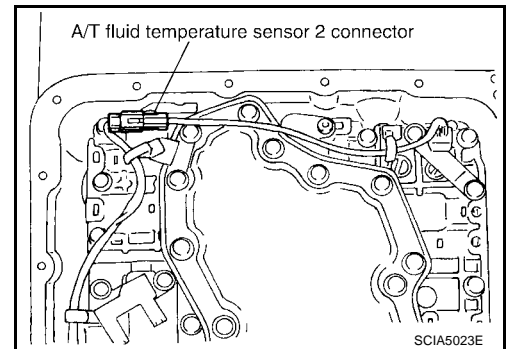

4. Securely fasten A/T fluid temperature sensor 2 harness with terminal clips.

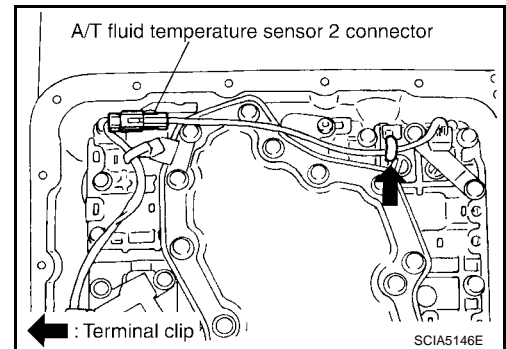

5. Install oil pan in transmission case.
 - a. Install new oil pan gasket in oil pan.

CAUTION:

- Do not reuse oil pan gasket.
- Install it in the direction to align hole positions.
- Complete remove all moisture, oil and old sealant, etc. from oil pan gasket mounting surfaces.

ON-VEHICLE SERVICE

- b. Install new oil pan (with oil pan gasket) to transmission case.

CAUTION:

- Install it so that drain plug comes to the position as shown.
- Be careful not to pinch harnesses.
- Complete remove all moisture, oil and old sealant, etc. from oil pan mounting surfaces.

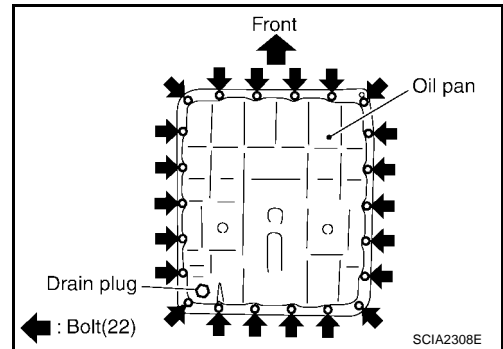

- c. Tighten oil pan bolts to the specified torque in numerical order as shown after temporarily tightening them. Refer to [AT-250, "COMPONENTS"](#).

CAUTION:

Do not reuse oil pan bolts.

6. Tighten drain plug to the specified torque. Refer to [AT-250, "COMPONENTS"](#).

CAUTION:

Do not reuse drain plug gasket.

7. Pour ATF into transmission assembly. Refer to [MA-23, "Changing A/T Fluid"](#).
8. Connect the negative battery terminal

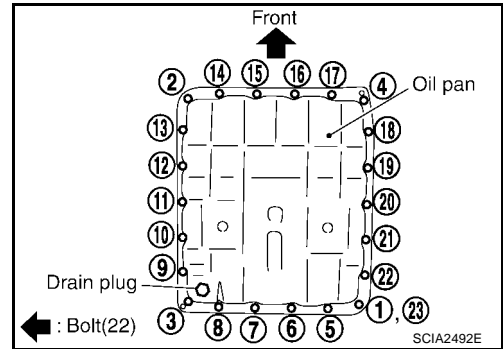

A

B

AT

D

E

F

G

H

I

J

K

L

M

Rear Oil Seal REMOVAL AND INSTALLATION

Removal

1. Remove rear propeller shaft. Refer to [PR-8, "Removal and Installation"](#) .
2. Remove transfer from transmission (4WD models). Refer to [TF-87, "Removal and Installation"](#) .
3. Remove rear oil seal using a flat-bladed screwdriver or suitable tool.

CAUTION:

Be careful not to scratch rear extension assembly (2WD models) or adapter case assembly (4WD models).

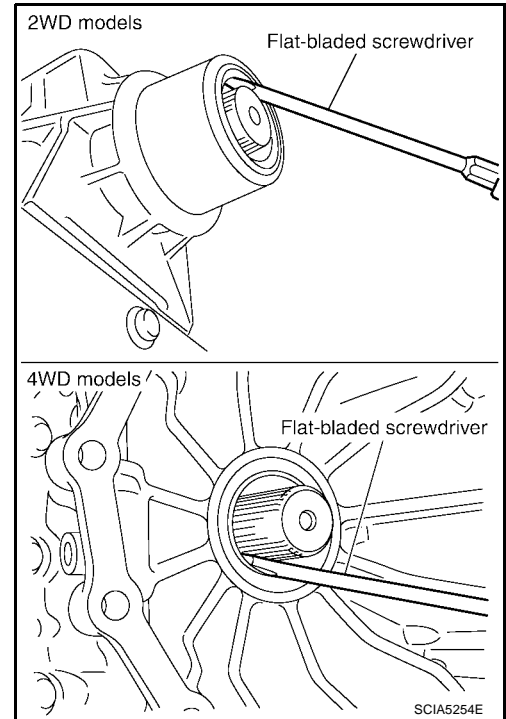

Installation

CAUTION:

After completing installation, check A/T fluid leakage and fluid level. Refer to [MA-23, "Changing A/T Fluid"](#) and [MA-21, "Checking A/T Fluid"](#) .

1. Install new rear oil seal into the extension case (2WD models) or adapter case (4WD models) until it is flush with component face, using Tool or suitable drift.

CAUTION:

- Apply ATF to rear oil seal.
- Do not reuse rear oil seal

2. Install transfer on transmission (4WD models). Refer to [TF-87, "Removal and Installation"](#) .
3. Install rear propeller shaft. Refer to [PR-8, "Removal and Installation"](#) .

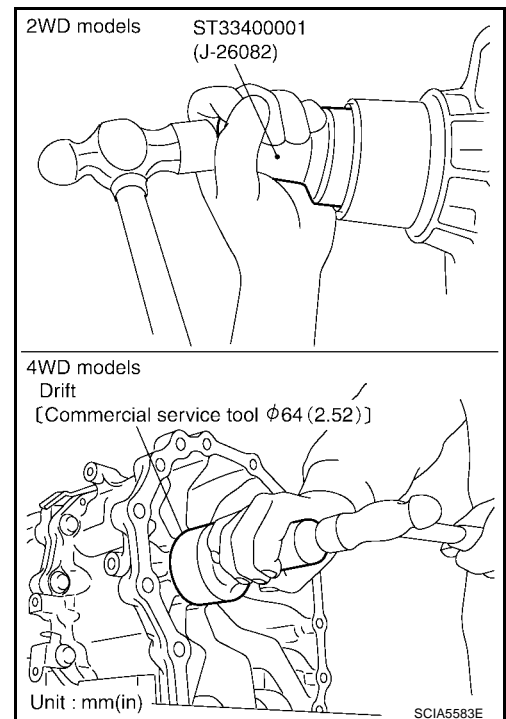

AIR BREATHER HOSE

AIR BREATHER HOSE

PFP:31098

Removal and Installation 4X2

ECS00B3G

Refer to the figure below for air breather hose removal and installation procedure.

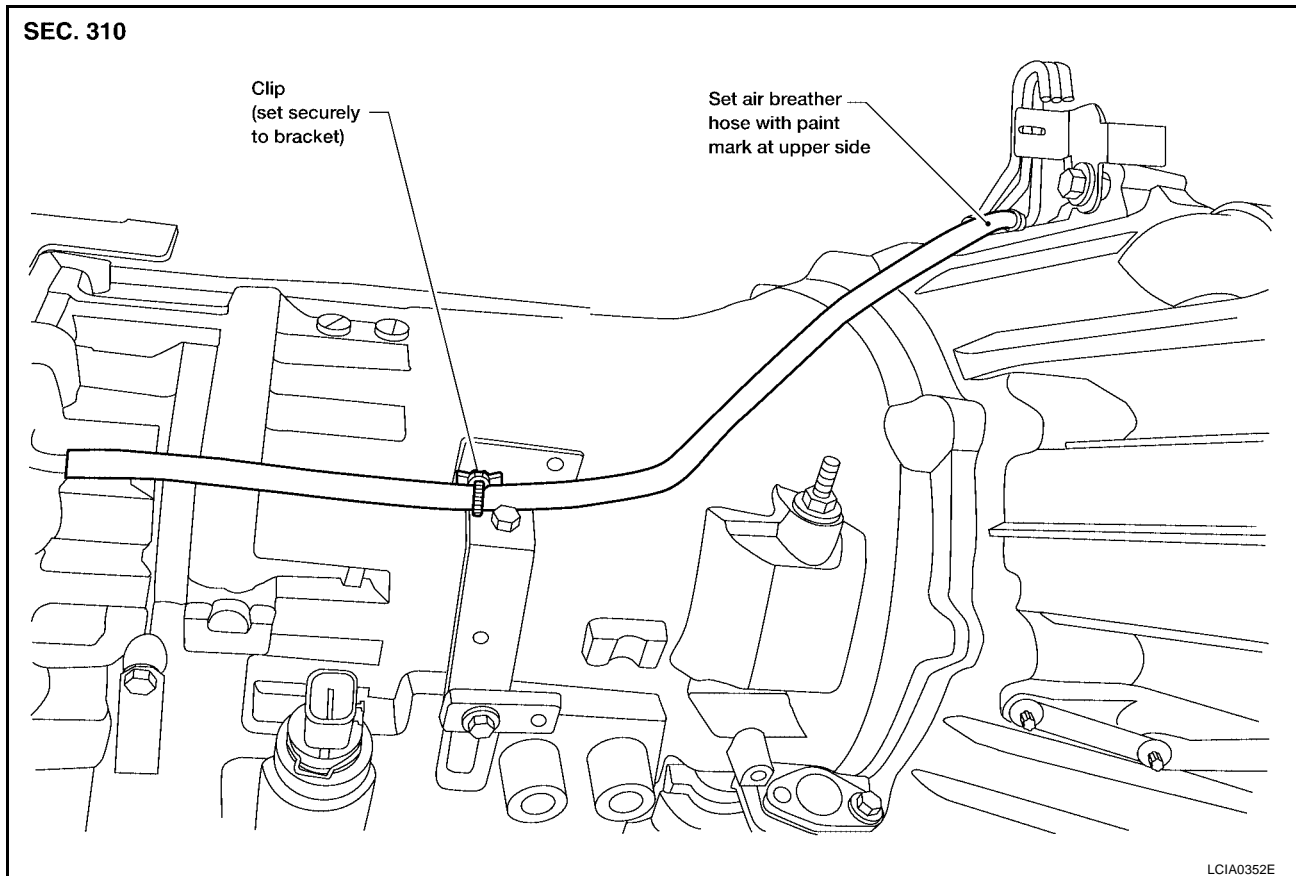

CAUTION:

- When installing an air breather hose, be careful not to crush or block the hose by folding or bending.
- When inserting a hose in to the transmission tube, be sure to insert it fully until its end reaches the tube bend portion.

A

B

AT

D

E

F

G

H

I

J

K

L

M

AIR BREATHER HOSE

4X4

Refer to the figure below for air breather hose removal and installation procedure.

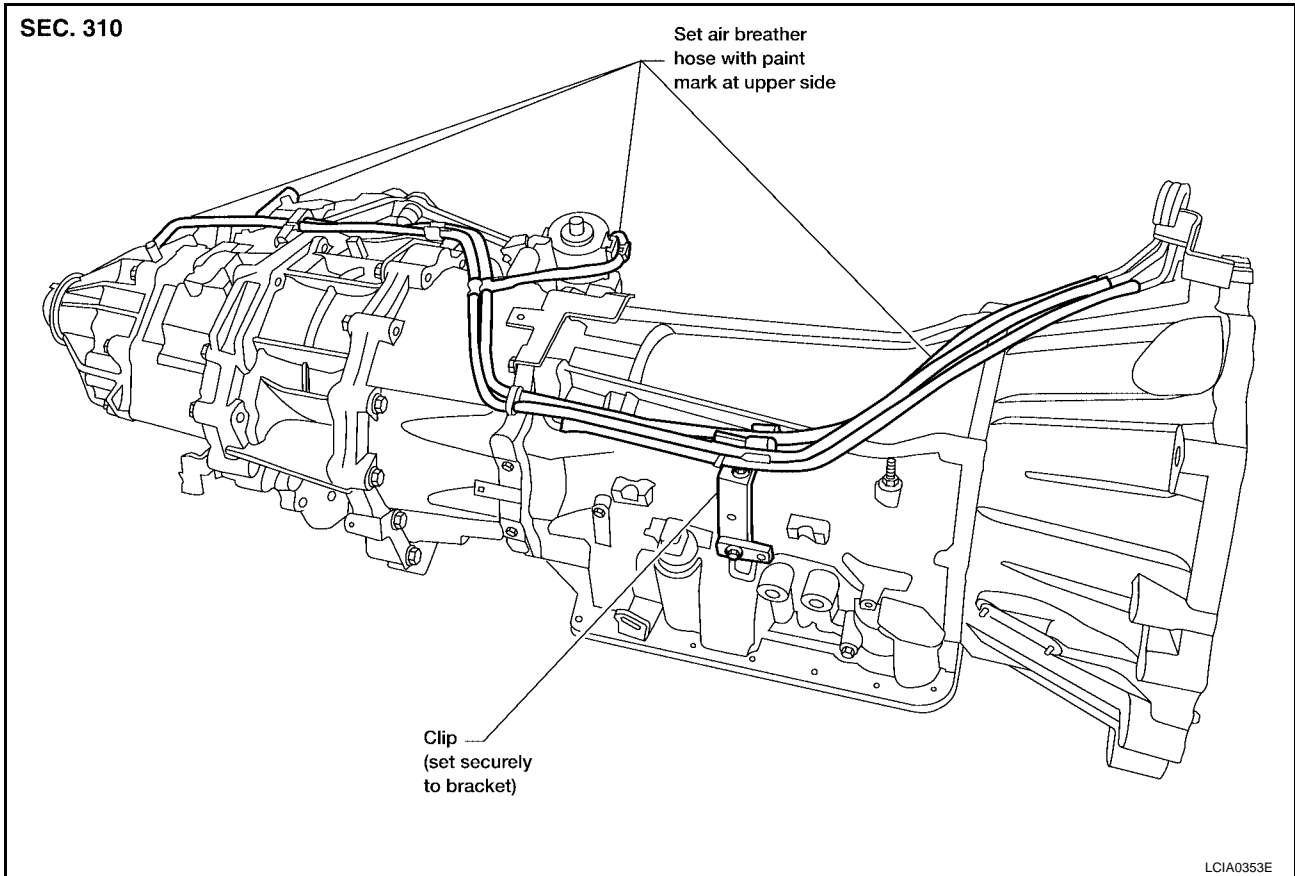

CAUTION:

- When installing an air breather hose, be careful not to be crushed or blocked by folding or bending the hose.
- When inserting a hose to the transmission tube, be sure to insert it fully until its end reaches the tube bend portion.

TRANSMISSION ASSEMBLY

PFP:31020

ECS00B3H

TRANSMISSION ASSEMBLY

Removal and Installation (4x2) COMPONENTS

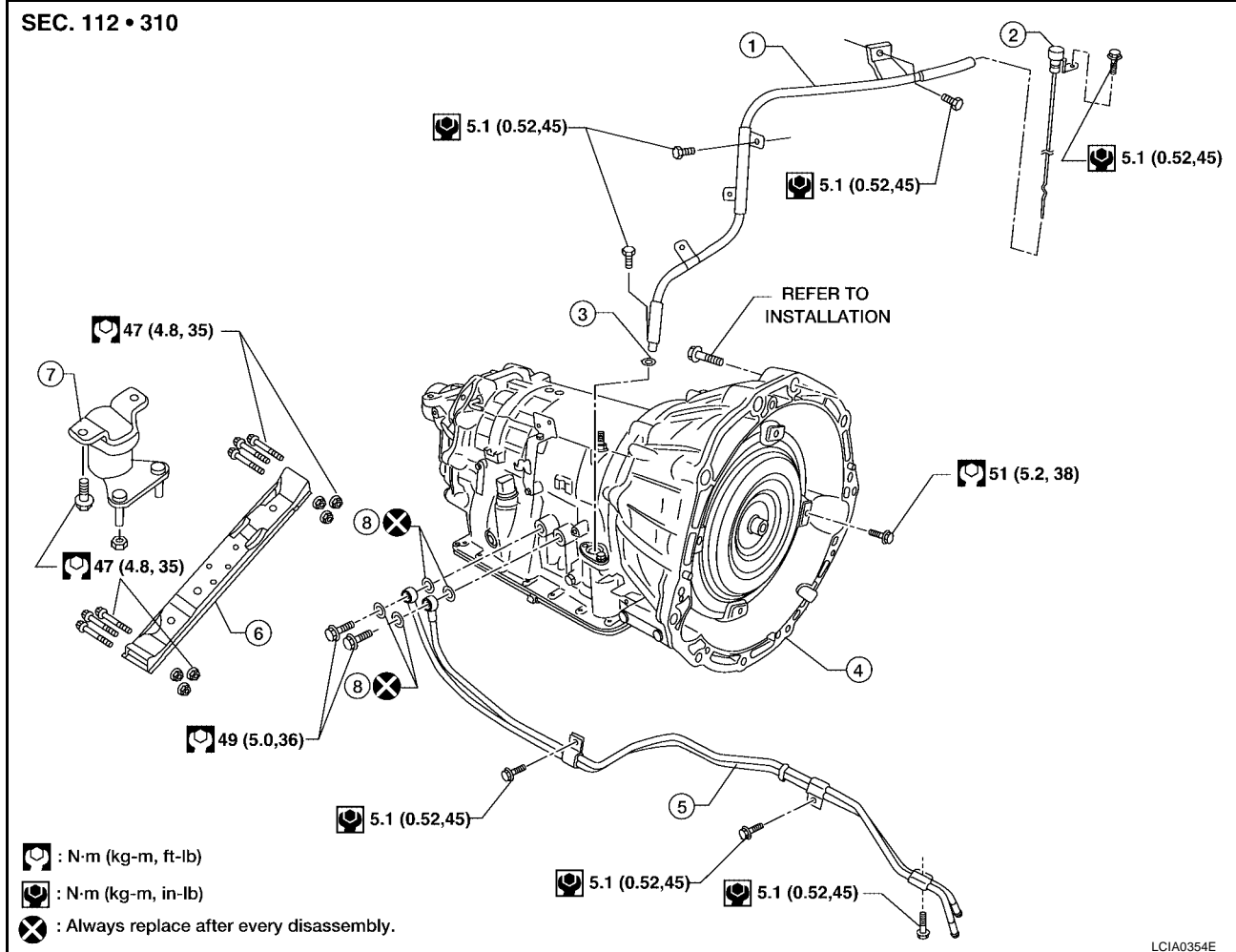

- | | | |
|-----------------------------|--------------------------|---------------------|
| 1. A/T fluid indicator pipe | 2. A/T fluid indicator | 3. O-ring |
| 4. Transmission assembly | 5. A/T fluid cooler tube | 6. A/T cross member |
| 7. Insulator | 8. Copper washers | |

REMOVAL

CAUTION:

When removing the A/T assembly from engine, first remove the crankshaft position sensor (POS) from the A/T assembly.

Be careful not to damage sensor edge.

1. Disconnect battery negative cable from battery negative terminal.
2. Remove engine cover.
3. Remove A/T fluid indicator gauge.
4. Remove engine under cover with power tool.
5. Remove exhaust front tube and center muffler with power tool. Refer to [EX-4, "REMOVAL"](#).
6. Remove propeller shaft. Refer to [PR-8, "Removal and Installation"](#).
7. Remove A/T control cable. Refer to [AT-236, "SHIFT CONTROL SYSTEM"](#).

TRANSMISSION ASSEMBLY

8. Remove crankshaft position sensor (POS) from A/T assembly.
9. Remove fluid cooler tube.
10. Remove dust cover from converter housing part.

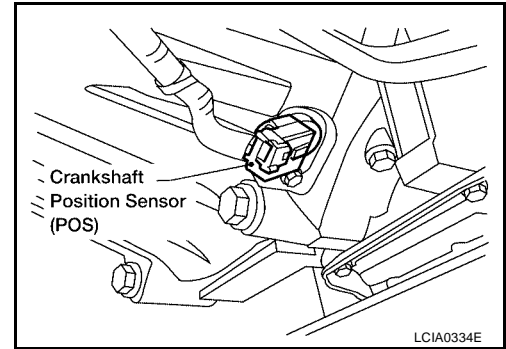

11. Turn crankshaft, and remove the four bolts for drive plate and torque converter.

CAUTION:

When turning crankshaft, turn it clockwise as viewed from the front of the engine.

12. Support A/T assembly with a transmission jack.

CAUTION:

When setting the transmission jack, be careful not to allow it to collide against the drain plug.

13. Remove cross member with power tool.
14. Remove air breather hose. Refer to [AT-263, "Removal and Installation"](#).
15. Disconnect A/T unit assembly connector.
16. Remove A/T fluid indicator pipe from A/T assembly.
17. Plug up openings such as the fluid charging pipe hole, etc.
18. Remove the A/T assembly to engine bolts with power tool.
19. Remove A/T assembly from vehicle with a transmission jack.
 - Secure torque converter to prevent it from dropping.
 - Secure A/T assembly to a jack.

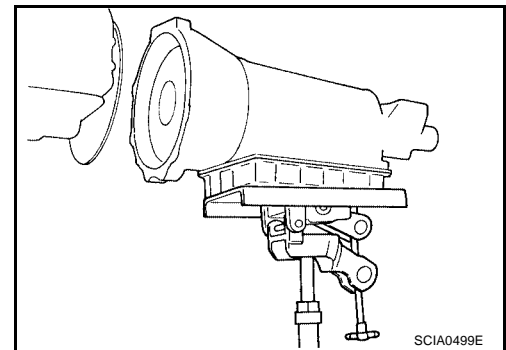
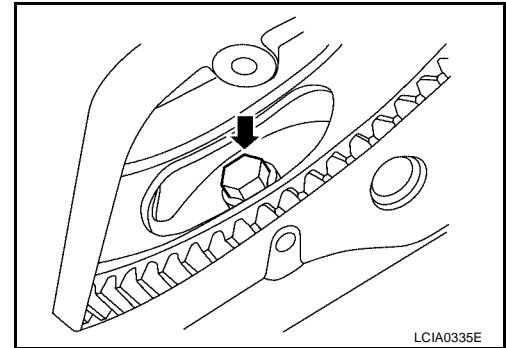

INSPECTION

Installation and Inspection of Torque Converter

- After inserting a torque converter to a transmission, be sure to check dimension A to ensure it is within the reference value limit.

Dimension A : 24.0 mm (0.94 in) or more

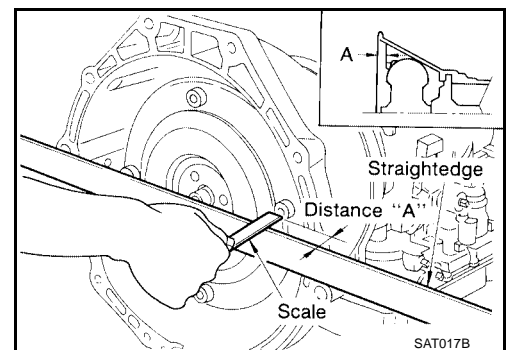

TRANSMISSION ASSEMBLY

INSTALLATION

Installation of the remaining components is in the reverse order of the removal.

- When installing transmission to the engine, attach the bolts as shown.

Transmission to engine bolts : 113 N·m (12 kg·m, 83 ft·lb)

NOTE:

*: No.2 bolt also secures air breather vent.

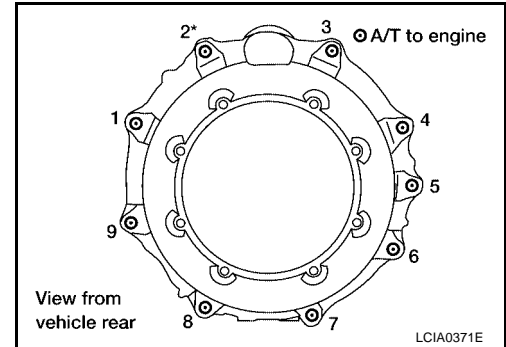

- Align the positions of bolts for drive plate with those of the torque converter, and temporarily tighten the bolts. Then, tighten the bolts to the specified torque.

CAUTION:

- When turning crankshaft, turn it clockwise as viewed from the front of the engine.
- After converter is installed to drive plate, rotate crankshaft several turns and check to be sure that transmission rotates freely without binding.
- Install crankshaft position sensor (POS).
- After completing installation, check fluid leakage, fluid level, and the positions of A/T. Refer to [MA-23, "Changing A/T Fluid"](#) , [AT-238, "Adjustment of A/T Position"](#) , [AT-238, "Checking of A/T Position"](#) .

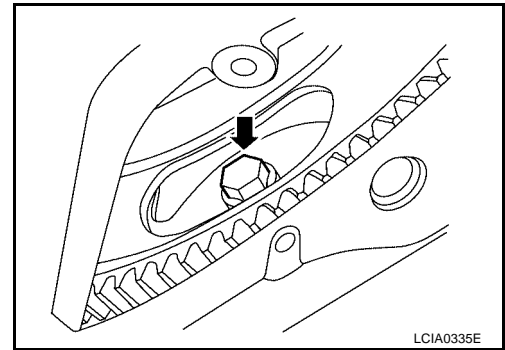

TRANSMISSION ASSEMBLY

ECS00B31

Removal and Installation (4x4) COMPONENTS

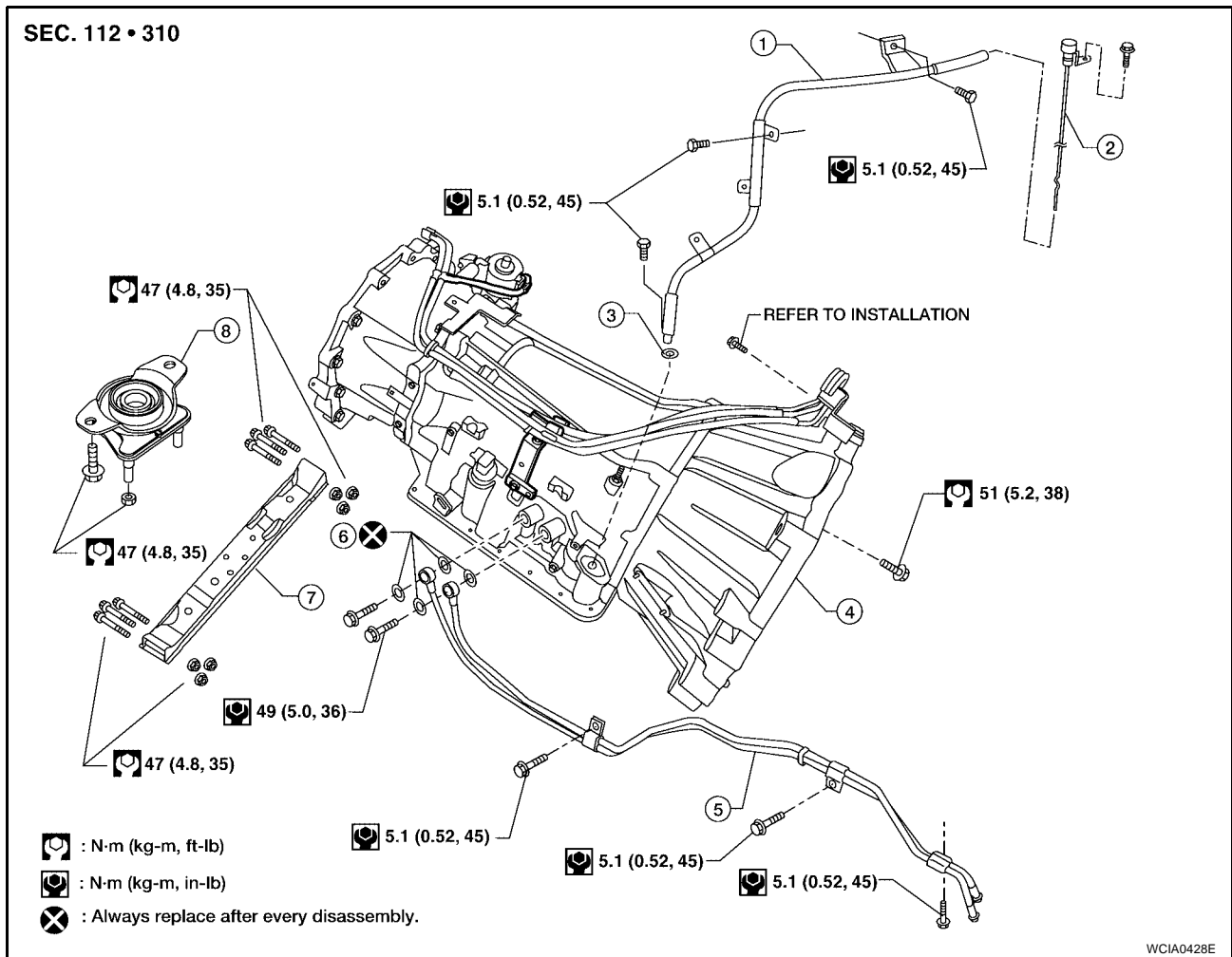

REMOVAL

CAUTION:

When removing the A/T assembly from engine, first remove the crankshaft position sensor (POS) from the A/T assembly.

Be careful not to damage sensor edge.

1. Disconnect battery negative cable from battery negative terminal.
2. Remove engine cover with power tool.
3. Remove A/T fluid indicator.
4. Remove engine under cover with power tool.
5. Remove exhaust front tube and center muffler with power tool. Refer to [EX-4, "REMOVAL"](#).
6. Remove propeller shaft. Refer to [PR-4, "Removal and Installation"](#), [PR-8, "Removal and Installation"](#).
7. Remove A/T control cable. Refer to [AT-236, "SHIFT CONTROL SYSTEM"](#).

TRANSMISSION ASSEMBLY

8. Remove crankshaft position sensor (POS) from A/T assembly.
9. Disconnect A/T fluid cooler tube from A/T assembly.
10. Remove dust cover from converter housing part.

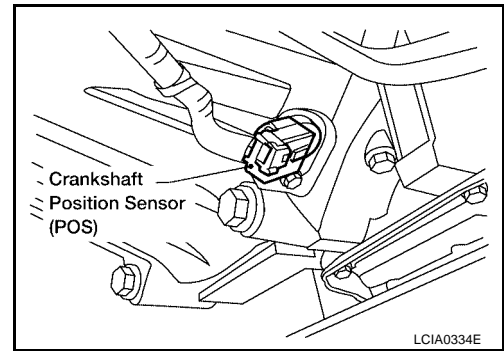

11. Turn crankshaft, and remove the four bolts for drive plate and torque converter.

CAUTION:

When turning crankshaft, turn it clockwise as viewed from the front of the engine.

12. Support A/T assembly with a transmission jack.

CAUTION:

When setting the transmission jack, be careful not to allow it to collide against the drain plug.

13. Remove cross member with power tool.

14. Tilt the transmission slightly to keep the clearance between body and transmission, and then disconnect air breather hose from charging pipe. Refer to [AT-263](#), "[Removal and Installation](#)".

15. Disconnect A/T unit assembly connector and transfer unit connector.

16. Remove A/T fluid indicator pipe.

17. Plug up openings such as the fluid charging pipe hole, etc.

18. Remove A/T assembly to engine bolts with power tool.

19. Remove A/T assembly with transfer from vehicle, using Tool.

Tool number : — (J-47002)

CAUTION:

- Secure torque converter to prevent it from dropping.
- Secure A/T assembly to a jack.

NOTE:

The actual special service tool may differ from tool as shown.

20. Remove transfer from A/T assembly. Refer to [TF-87](#), "[Removal and Installation](#)".

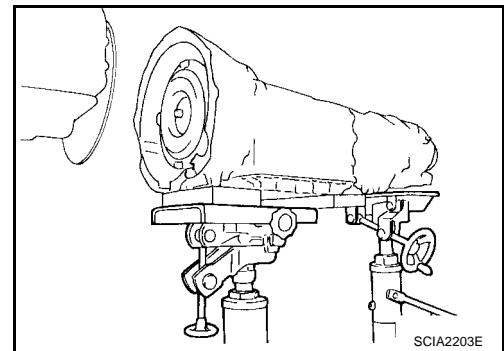
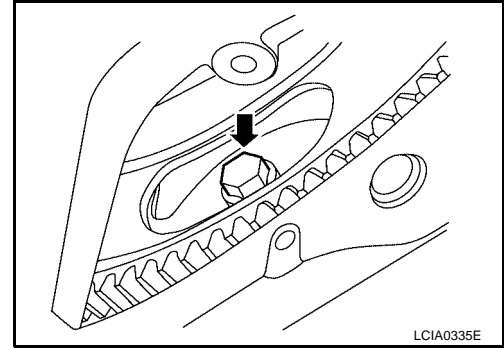

INSPECTION

Installation and Inspection of Torque Converter

- After inserting a torque converter to a transmission, be sure to check dimension A to ensure it is within the reference value limit.

Dimension A : 24.0 mm (0.94 in) or more

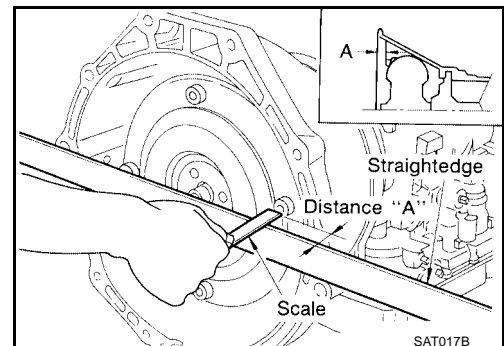

TRANSMISSION ASSEMBLY

INSTALLATION

Installation is in the reverse order of removal.

- When installing transmission to the engine, attach the bolts as shown.

Transmission to engine bolts : 113 N·m (12 kg·m, 83 ft·lb)

NOTE:

*: No.2 bolt also secures air breather vent.

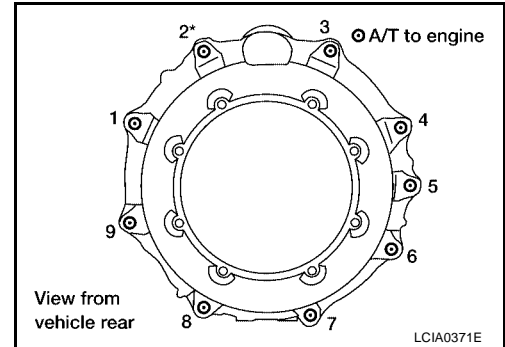

- Align the positions of bolts for drive plate with those of the torque converter, and temporarily tighten the bolts. Then, tighten the bolts with the specified torque.

CAUTION:

- **When turning crankshaft, turn it clockwise as viewed from the front of the engine.**
- **After converter is installed to drive plate, rotate crankshaft several turns and check to be sure that transmission rotates freely without binding.**
- Install crankshaft position sensor (POS).
- After completing installation, check fluid leakage, fluid level, and the positions of A/T. Refer to [MA-23, "Changing A/T Fluid"](#) , [AT-238, "Adjustment of A/T Position"](#) , [AT-238, "Checking of A/T Position"](#) .

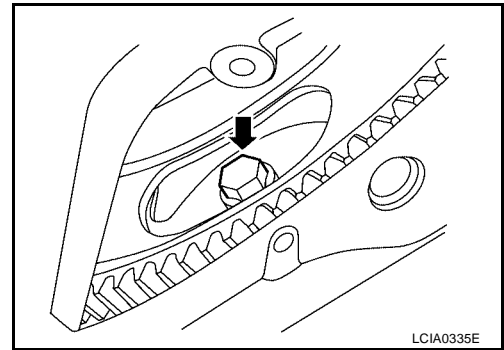

OVERHAUL

PF0:0000

ECS00B3J

OVERHAUL Components

SEC.311·313·314·315

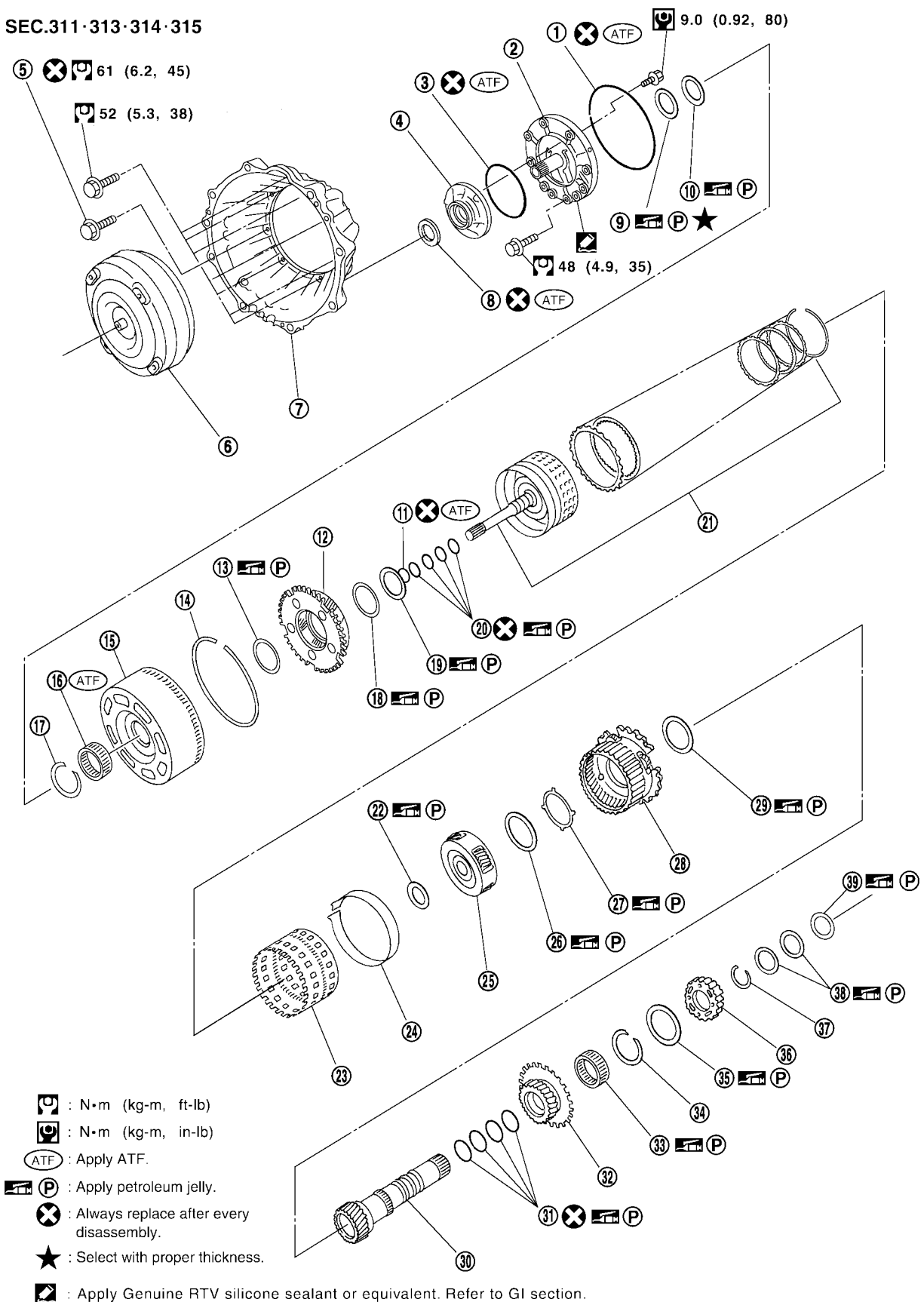

- : N·m (kg-m, ft-lb)
- : N·m (kg-m, in-lb)
- (ATF) : Apply ATF.
- (P) : Apply petroleum jelly.
- (X) : Always replace after every disassembly.
- ★ : Select with proper thickness.
- : Apply Genuine RTV silicone sealant or equivalent. Refer to GI section.

A
B
AT
D
E
F
G
H
I
J
K
L
M

OVERHAUL

- | | | |
|---------------------------|------------------------------|-------------------------------------|
| 1. O-ring | 2. Oil pump cover | 3. O-ring |
| 4. Oil pump housing | 5. Self-sealing bolt | 6. Torque converter |
| 7. Converter housing | 8. Oil pump housing oil seal | 9. Bearing race |
| 10. Needle bearing | 11. O-ring | 12. Front carrier assembly |
| 13. Needle bearing | 14. Snap ring | 15. Front sun gear |
| 16. 3rd one-way clutch | 17. Snap ring | 18. Bearing race |
| 19. Needle bearing | 20. Seal ring | 21. Input clutch assembly |
| 22. Needle bearing | 23. Rear internal gear | 24. Brake band |
| 25. Mid carrier assembly | 26. Needle bearing | 27. Bearing race |
| 28. Rear carrier assembly | 29. Needle bearing | 30. Mid sun gear |
| 31. Seal ring | 32. Rear sun gear | 33. 1st one-way clutch |
| 34. Snap ring | 35. Needle bearing | 36. High and low reverse clutch hub |
| 37. Snap ring | 38. Bearing race | 39. Bearing race |
| 40. Needle bearing | | |

OVERHAUL

SEC.315· 316

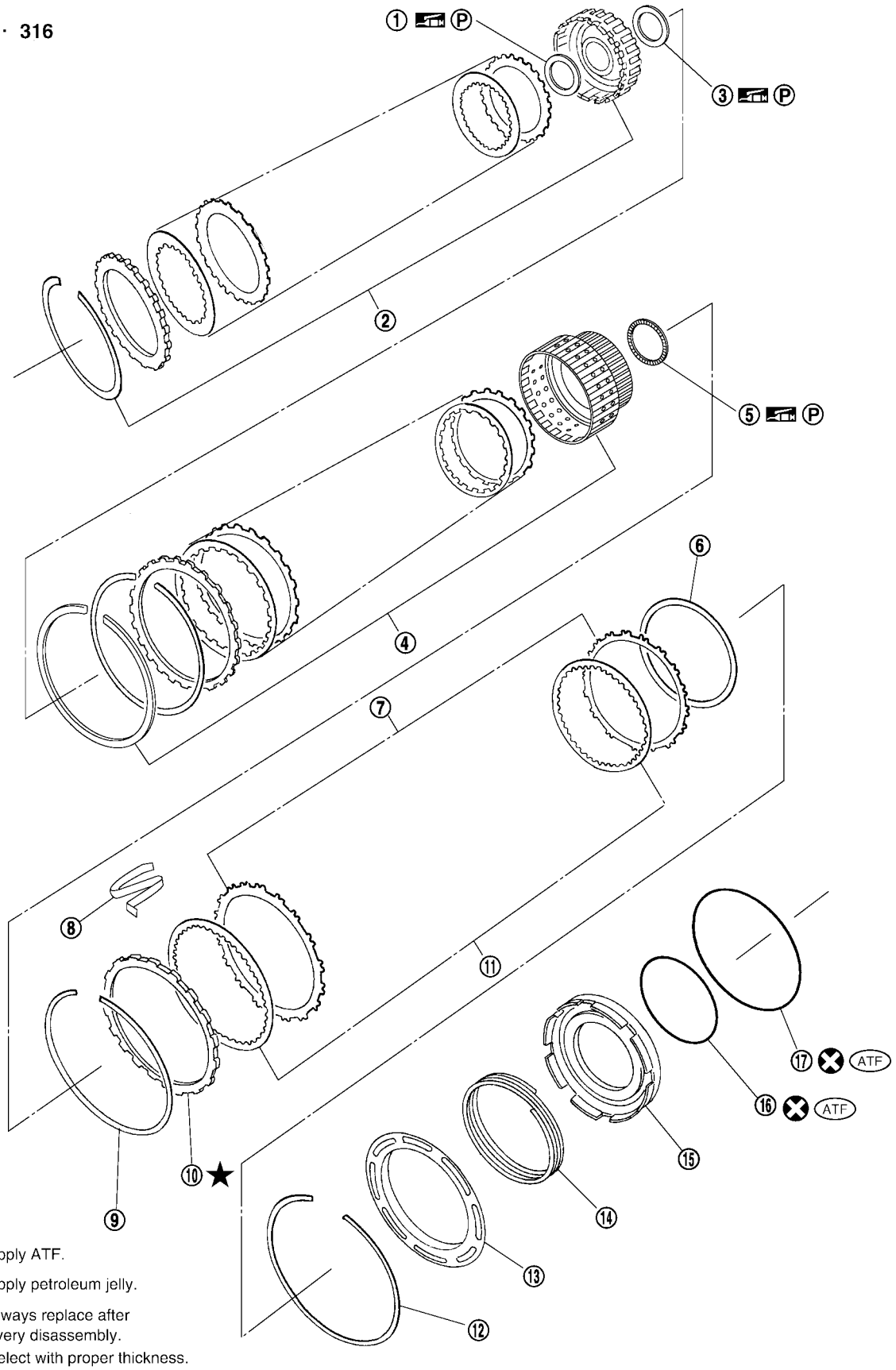

A
B
AT
D
E
F
G
H
I
J
K
L
M

1. Bearing race

2. High and low reverse clutch assembly

3. Needle bearing

4. Direct clutch assembly

5. Needle bearing

6. Reverse brake dish plate

SCIA5181E

OVERHAUL

- 7. Reverse brake driven plate
- 10. Reverse brake retaining plate
- 13. Spring retainer
- 16. D-ring

- 8. N-sprig
- 11. Reverse brake drive plate
- 14. Return spring
- 17. Lip seal

- 9. Snap ring
- 12. Snap ring
- 15. Reverse brake piston

OVERHAUL

2WD models

SEC.313 · 314 · 315 · 316 · 317 · 319

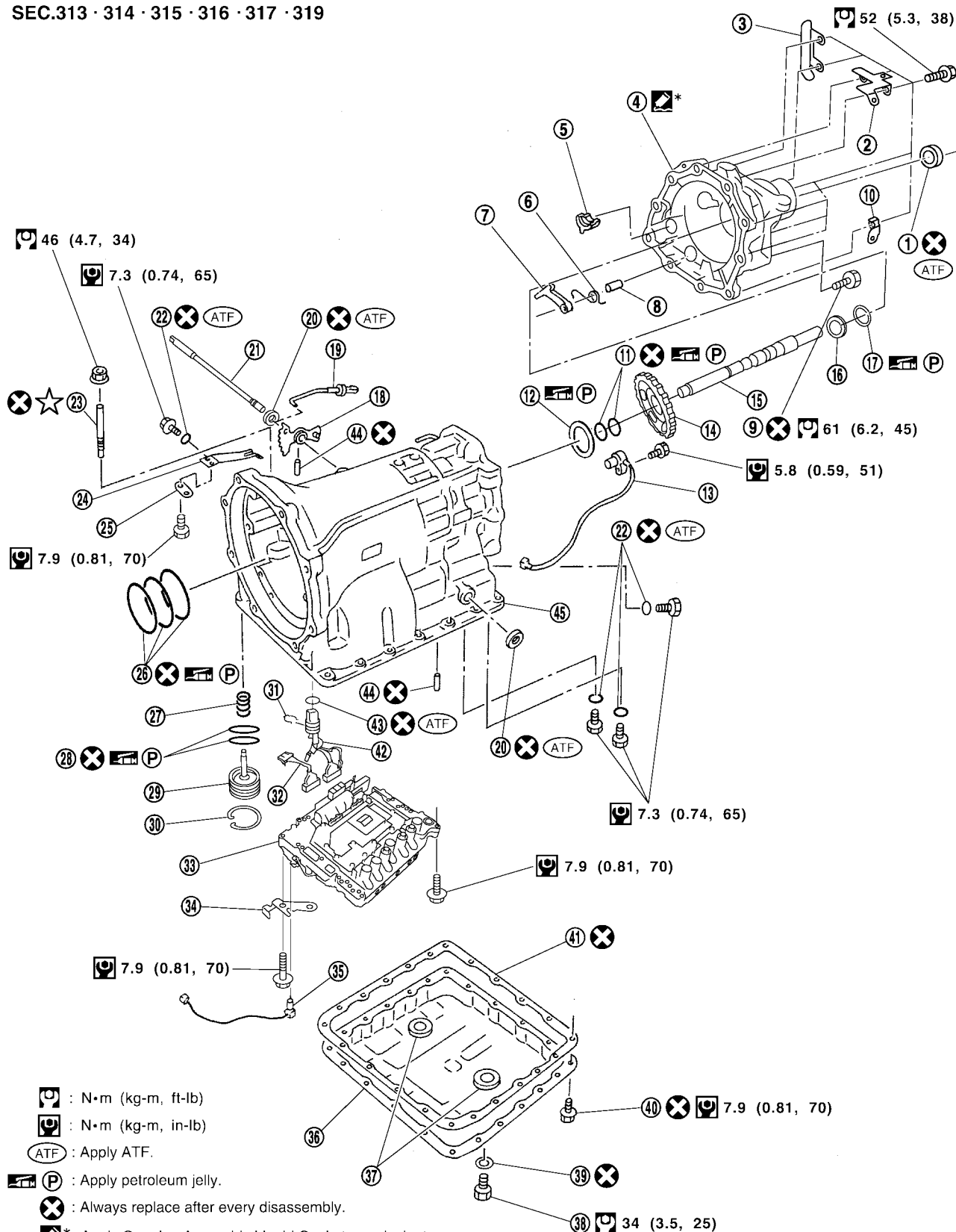

- : N·m (kg-m, ft-lb)
- : N·m (kg-m, in-lb)
- : Apply ATF.
- : Apply petroleum jelly.
- : Always replace after every disassembly.
- * : Apply Genuine Anaerobic Liquid Gasket or equivalent. Refer to GI section.
- : Adjustment is required.

- 1. Rear oil seal
- 4. Rear extension

- 2. Bracket
- 5. Parking actuator support

- 3. Bracket
- 6. Return spring

SCIA5663E

OVERHAUL

- | | | |
|---------------------------|------------------------------------|----------------------------|
| 7. Parking pawl | 8. Pawl shaft | 9. Self-sealing bolt |
| 10. Bracket | 11. Seal ring | 12. Needle bearing |
| 13. Revolution sensor | 14. Parking gear | 15. Output shaft |
| 16. Bearing race | 17. Needle bearing | 18. Manual plate |
| 19. Parking rod | 20. Manual shaft oil seal | 21. Manual shaft |
| 22. O-ring | 23. Band servo anchor end pin | 24. Detent spring |
| 25. Spacer | 26. Seal rings | 27. Return spring |
| 28. O-ring | 29. Servo assembly | 30. Snap ring |
| 31. Snap ring | 32. Sub-harness | 33. Control valve with TCM |
| 34. Bracket | 35. A/T fluid temperature sensor 2 | 36. Oil pan |
| 37. Magnet | 38. Drain plug | 39. Drain plug gasket |
| 40. Oil pan mounting bolt | 41. Oil pan gasket | 42. Terminal cord assembly |
| 43. O-ring | 44. Retaining pin | 45. Transmission case |

OVERHAUL

4WD models

SEC.313 · 314 · 315 · 316 · 317 · 319

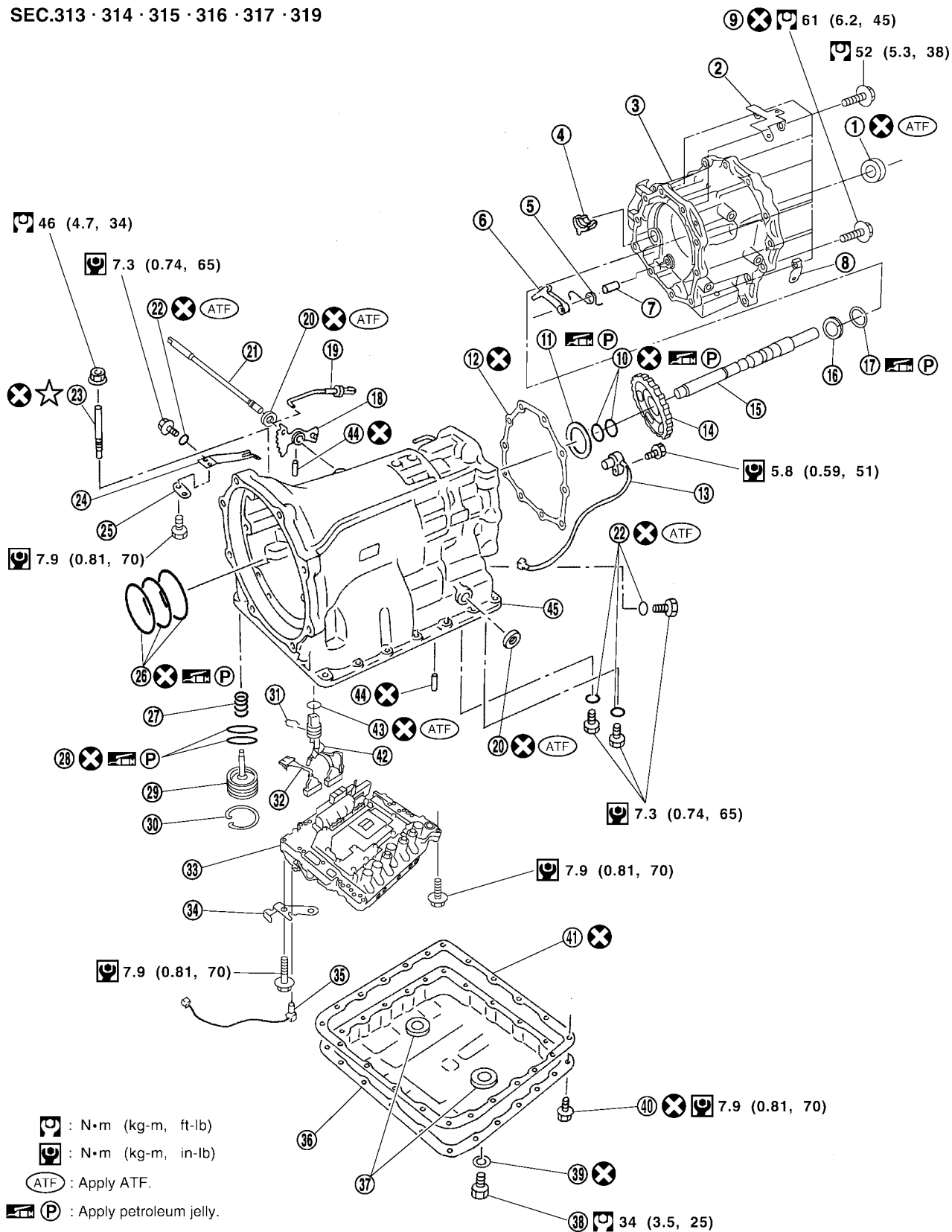

- 1. Rear oil seal
- 4. Parking actuator support

- 2. Bracket
- 5. Return spring

- 3. Adapter case
- 6. Parking pawl

A
B
AT

D
E
F
G
H
I
J
K
L
M

OVERHAUL

- | | | |
|---------------------------|------------------------------------|----------------------------|
| 7. Pawl shaft | 8. Bracket | 9. Self-sealing bolt |
| 10. Seal ring | 11. Needle bearing | 12. Gasket |
| 13. Revolution sensor | 14. Parking gear | 15. Output shaft |
| 16. Bearing race | 17. Needle bearing | 18. Manual plate |
| 19. Parking rod | 20. Manual shaft oil seal | 21. Manual shaft |
| 22. O-ring | 23. Band servo anchor end pin | 24. Detent spring |
| 25. Spacer | 26. Seal rings | 27. Return spring |
| 28. O-ring | 29. Servo assembly | 30. Snap ring |
| 31. Snap ring | 32. Sub-harness | 33. Control valve with TCM |
| 34. Bracket | 35. A/T fluid temperature sensor 2 | 36. Oil pan |
| 37. Magnet | 38. Drain plug | 39. Drain plug gasket |
| 40. Oil pan mounting bolt | 41. Oil pan gasket | 42. Terminal cord assembly |
| 43. O-ring | 44. Retaining pin | 45. Transmission case |

OVERHAUL

Oil Channel

ECS00B3K

2WD models

A

B

AT

D

E

F

G

H

I

J

K

L

M

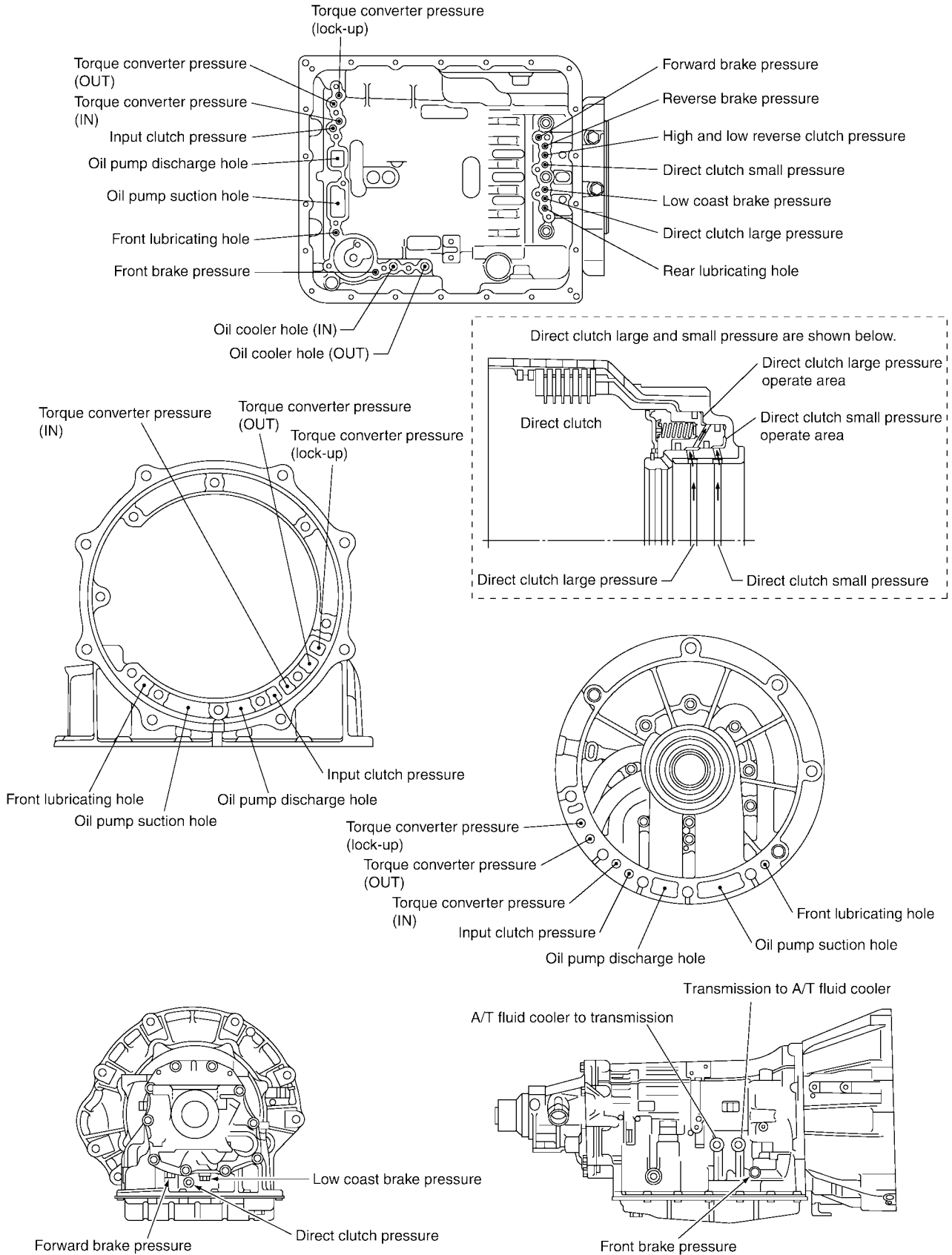

OVERHAUL

4WD models

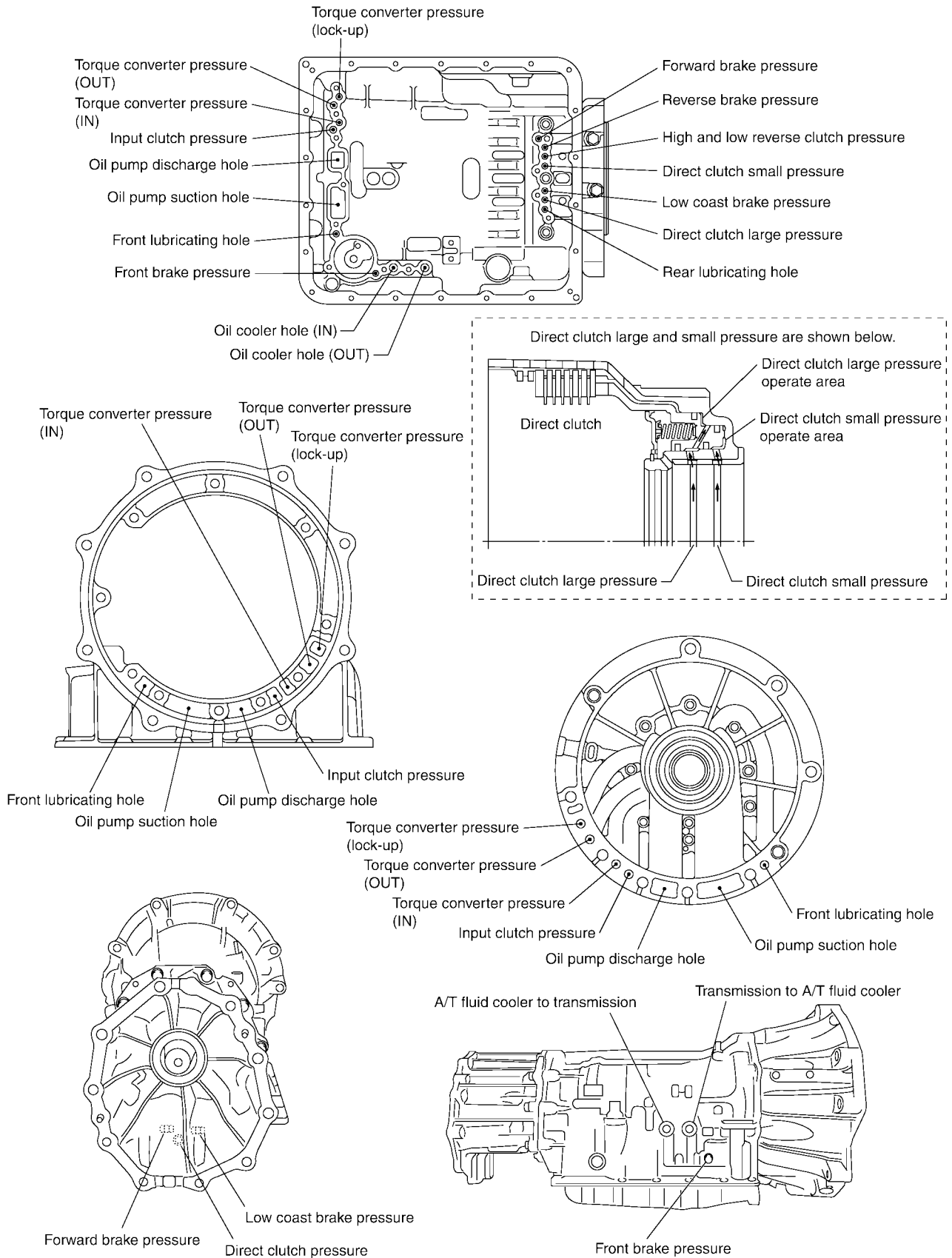

SCIA5189E

OVERHAUL

Locations of Adjusting Shims, Needle Bearings, Thrust Washers and Snap Rings

ECS00B3L

2WD models

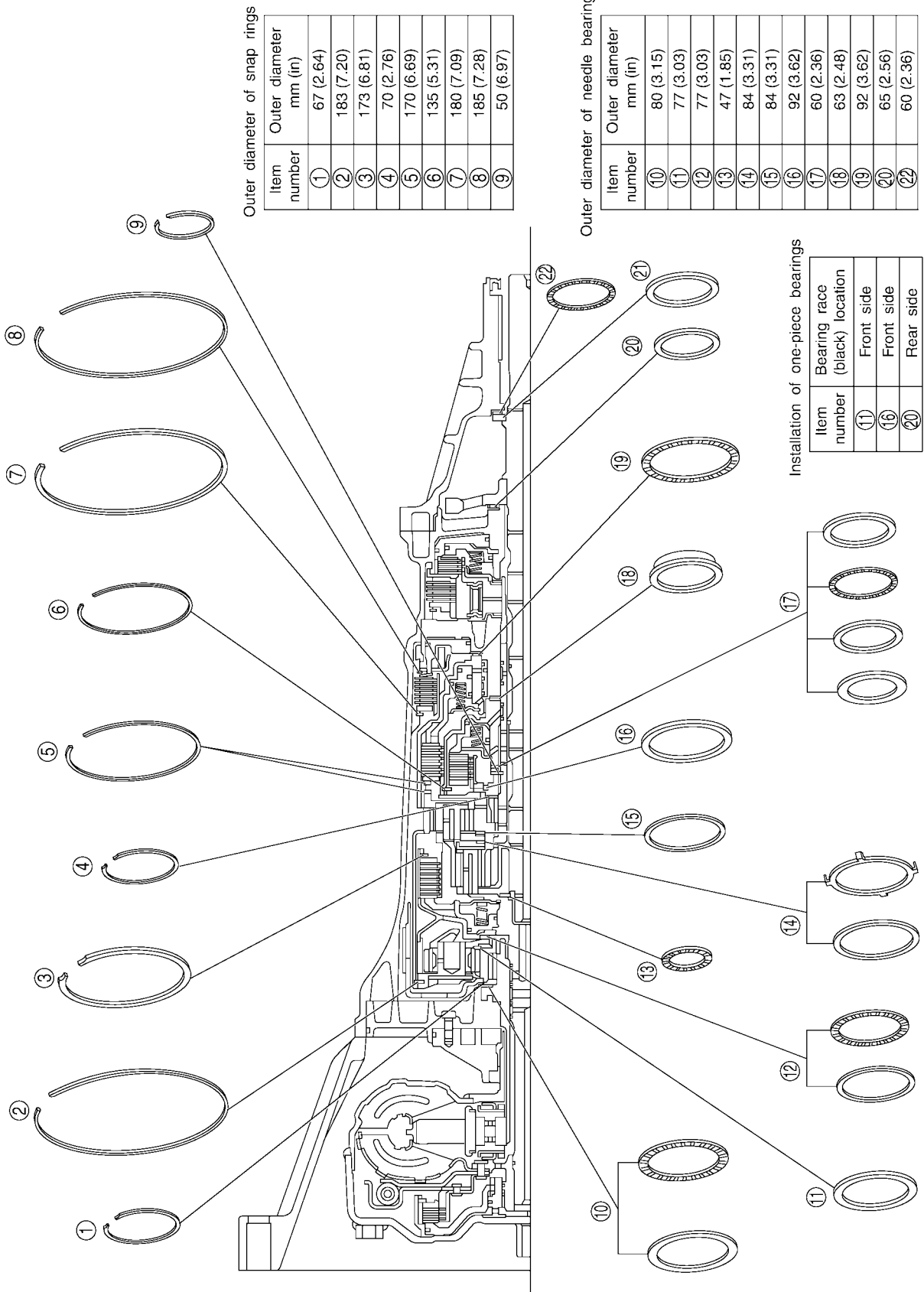

A
B
AT
D
E
F
G
H
I
J
K
L
M

OVERHAUL

4WD models

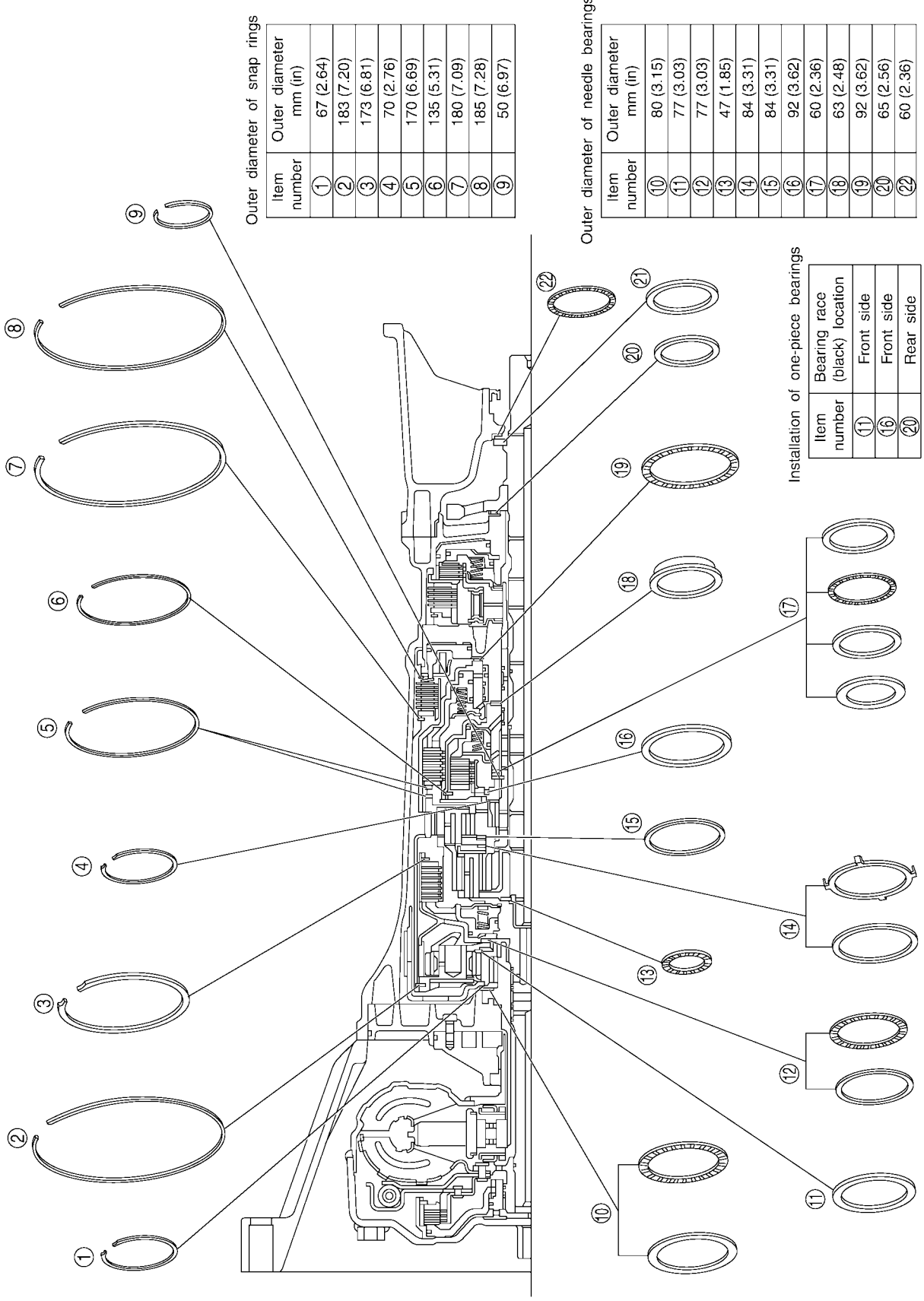

Outer diameter of snap rings

Item number	Outer diameter mm (in)
①	67 (2.64)
②	183 (7.20)
③	173 (6.81)
④	70 (2.76)
⑤	170 (6.69)
⑥	135 (5.31)
⑦	180 (7.09)
⑧	185 (7.28)
⑨	50 (6.97)

Outer diameter of needle bearings

Item number	Outer diameter mm (in)
⑩	80 (3.15)
⑪	77 (3.03)
⑫	77 (3.03)
⑬	47 (1.85)
⑭	84 (3.31)
⑮	84 (3.31)
⑯	92 (3.62)
⑰	60 (2.36)
⑱	63 (2.48)
⑲	92 (3.62)
⑳	65 (2.56)
㉔	60 (2.36)

Installation of one-piece bearings

Item number	Bearing race (black) location
⑪	Front side
⑱	Front side
㉔	Rear side

SCIA5197E

DISASSEMBLY

PFP:31020

Disassembly

ECS00CCW

CAUTION:

Do not disassemble parts behind Drum Support. Refer to [AT-15, "Cross-Sectional View \(2WD models\)"](#) or [AT-16, "Cross-Sectional View \(4WD models\)"](#).

1. Drain ATF through drain plug.
2. Remove torque converter by holding it firmly and turing while pulling straight out.

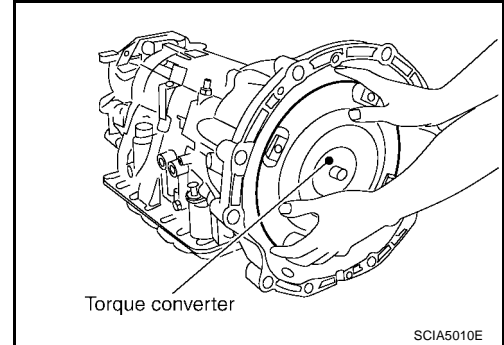

3. Check torque converter one-way clutch using check tool as shown.
 - a. Insert check tool into the groove of bearing support built into one-way clutch outer race.
 - b. When fixing bearing support with check tool, rotate one-way clutch spline using screwdriver.
 - c. Check that inner race rotates clockwise only. If not, replace torque converter assembly.

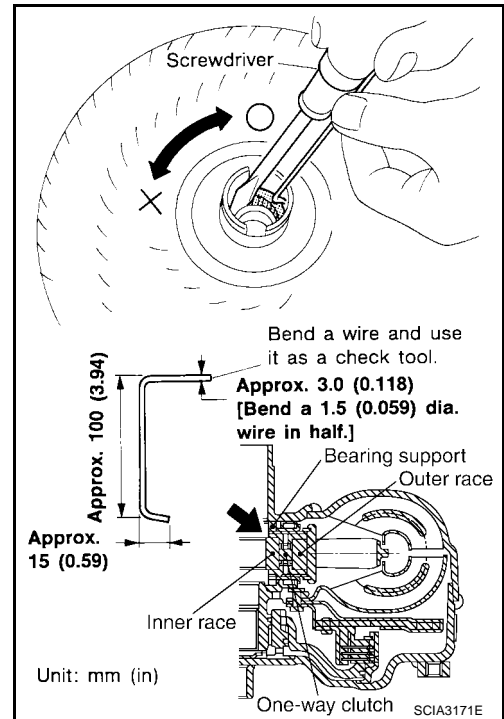

4. Remove converter housing from transmission case.

CAUTION:

Be careful not to scratch converter housing.

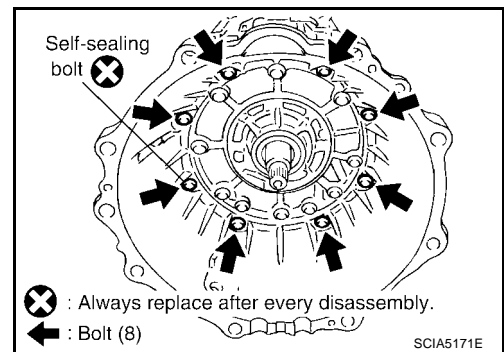

DISASSEMBLY

5. Remove O-ring from input clutch assembly.

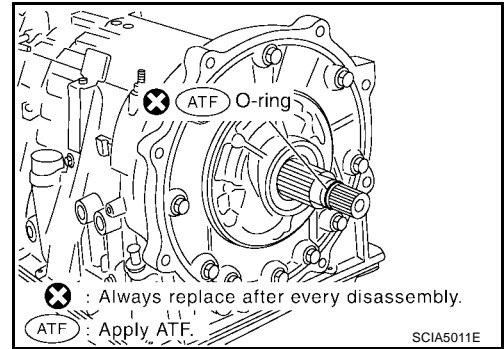

6. Remove tightening bolts for oil pump assembly and transmission case.

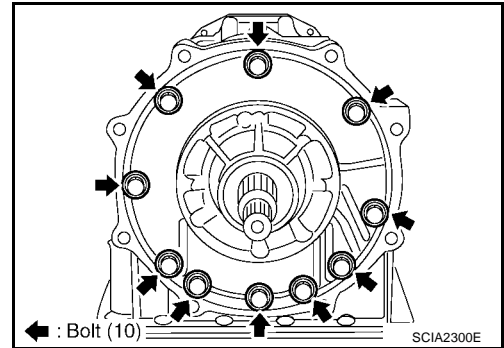

7. Attach sliding hammer to oil pump assembly and extract it evenly from transmission case.

CAUTION:

- Fully tighten sliding hammer screw.
- Make sure that bearing race is installed to the oil pump assembly edge surface.

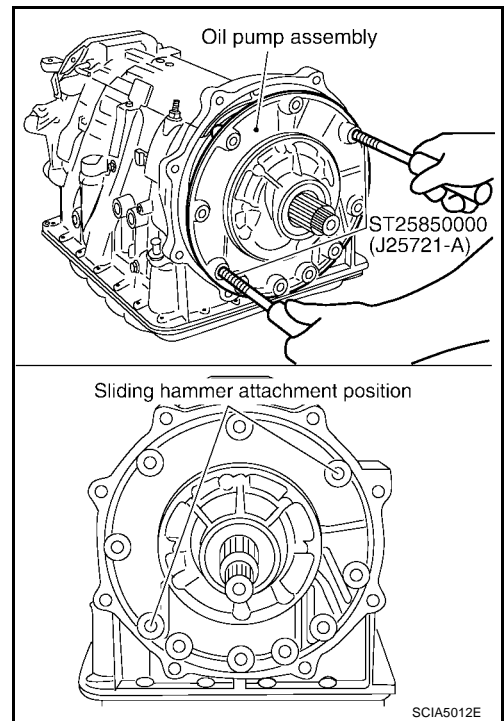

8. Remove O-ring from oil pump assembly.

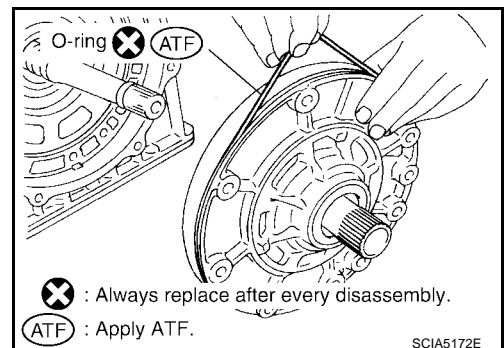

DISASSEMBLY

9. Remove bearing race from oil pump assembly.

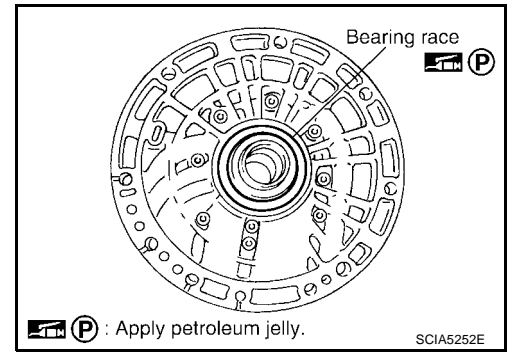

10. Remove needle bearing from front sun gear assembly.

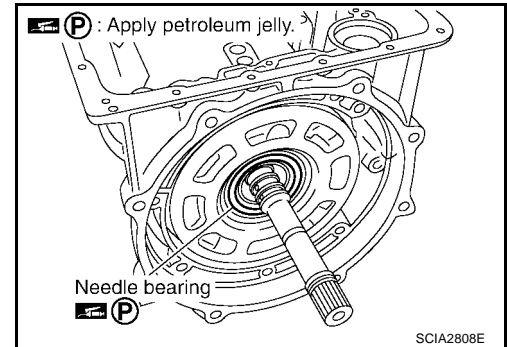

11. Remove front sun gear assembly from front carrier assembly.

NOTE:

Remove front sun gear assembly by rotating left/right.

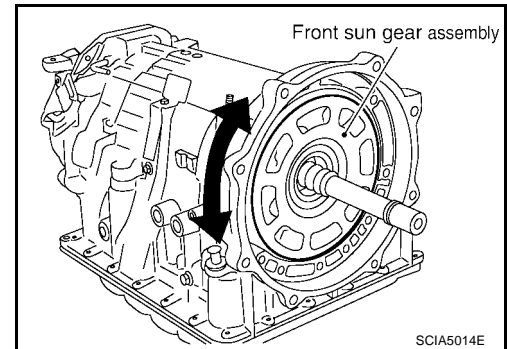

12. Remove seal rings from input clutch assembly.

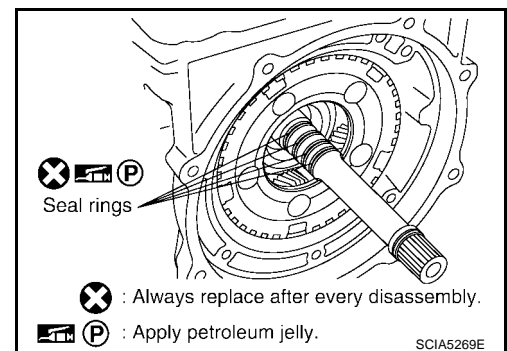

13. Remove front carrier assembly, input clutch assembly and rear internal gear as a unit.

CAUTION:

Be careful to remove it with needle bearing.

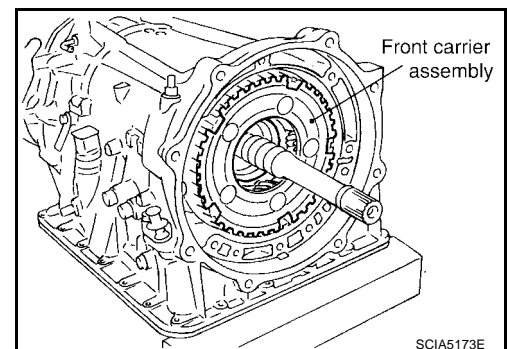

A
B
AT
D
E
F
G
H
I
J
K
L
M

DISASSEMBLY

14. Loosen lock nut and remove band servo anchor end pin from transmission case.

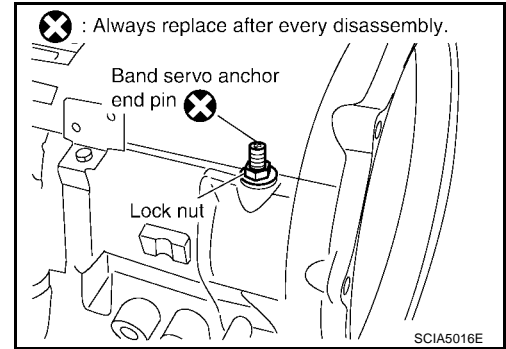

15. Remove brake band from transmission case.

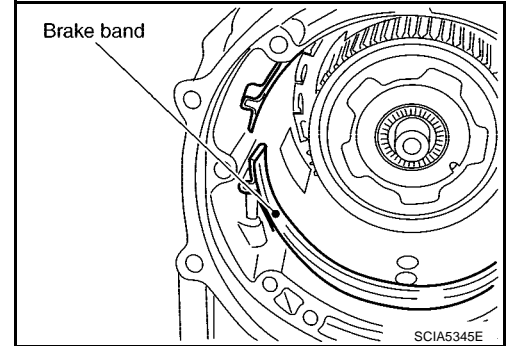

- To prevent brake linings from cracking or peeling, do not stretch the flexible band unnecessarily. When removing the brake band, always secure it with a clip as shown in the figure at left. Leave the clip in position after removing the brake band.
- Check brake band facing for damage, cracks, wear or burns.

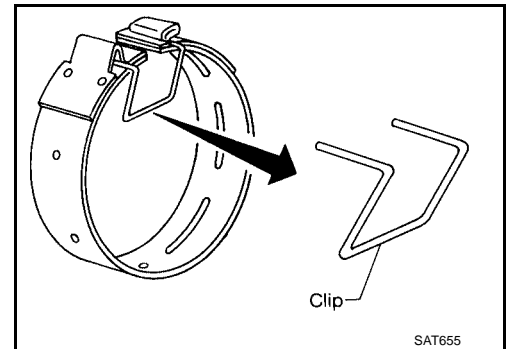

16. Remove mid carrier assembly and rear carrier assembly as a unit.

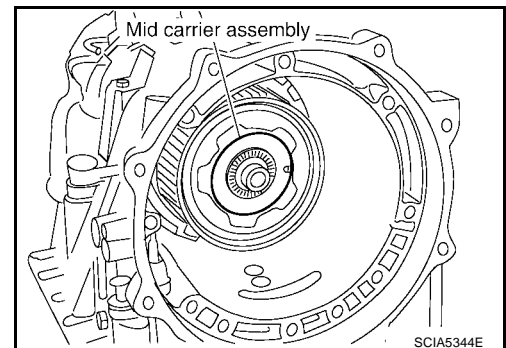

DISASSEMBLY

17. Remove mid carrier assembly from rear carrier assembly.

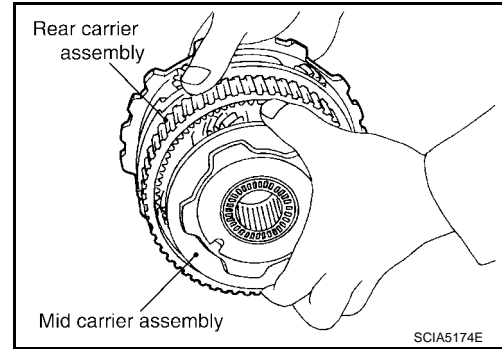

18. Remove needle bearing (front side) from mid carrier assembly.

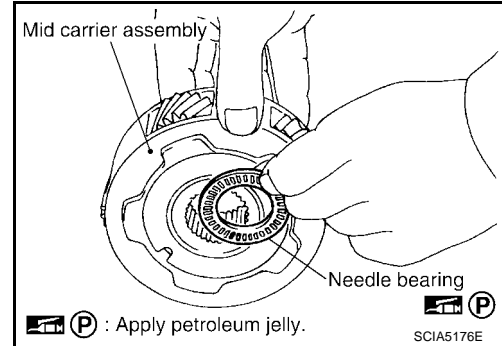

19. Remove needle bearing (rear side) from mid carrier assembly.

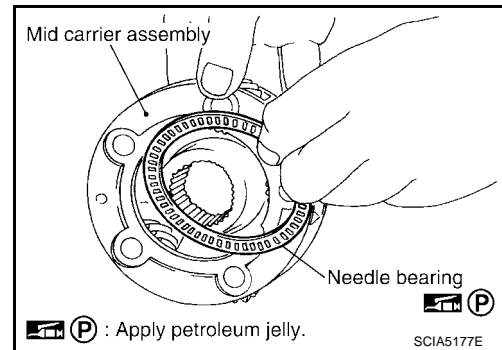

20. Remove bearing race from rear carrier assembly.

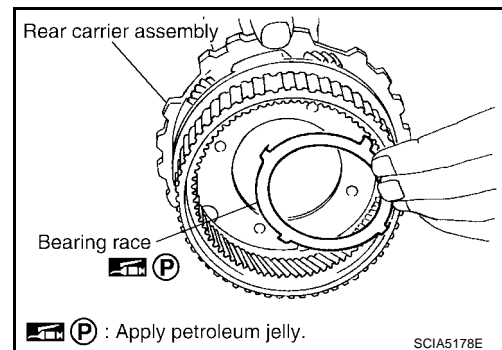

21. Remove needle bearing from rear carrier assembly.

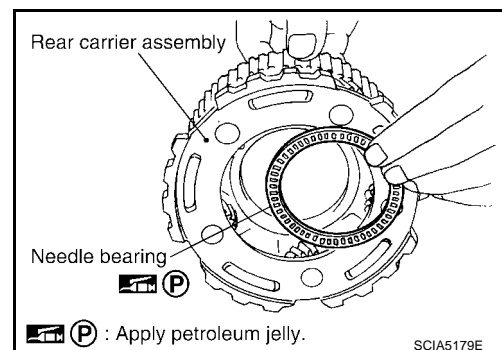

A
B
AT
D
E
F
G
H
I
J
K
L
M

DISASSEMBLY

22. Remove mid sun gear assembly, rear sun gear assembly and high and low reverse clutch hub as a unit.

CAUTION:

Be careful to remove them with bearing races and needle bearing.

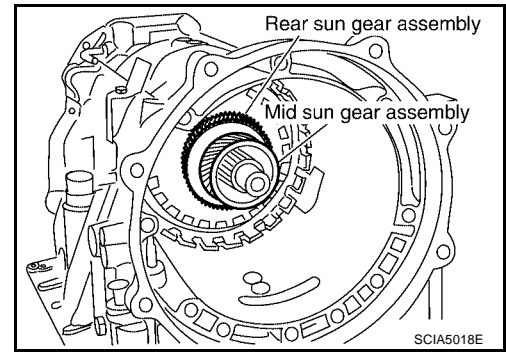

23. Remove high and low reverse clutch assembly from direct clutch assembly.

CAUTION:

Make sure that needle bearing is installed to the high and low reverse clutch assembly edge surface.

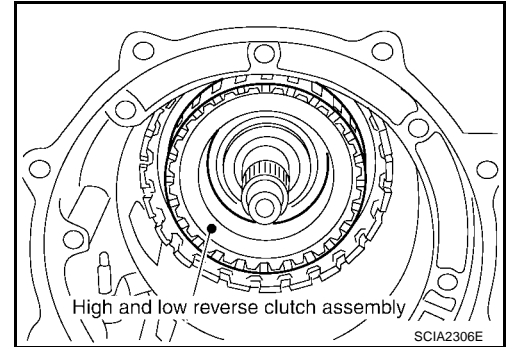

24. Remove direct clutch assembly from reverse brake.

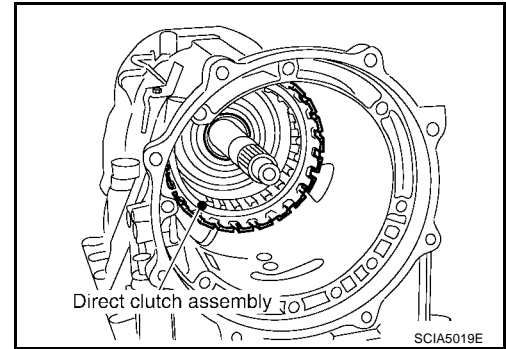

25. Remove needle bearing from drum support edge surface.

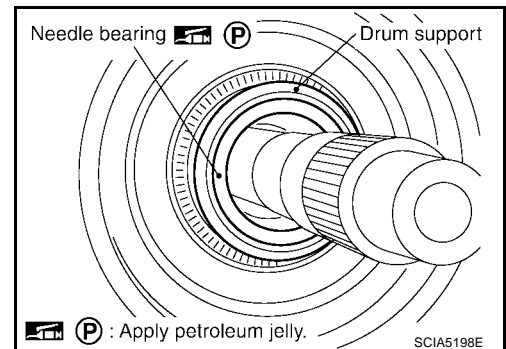

26. Remove snap ring from A/T assembly harness connector.

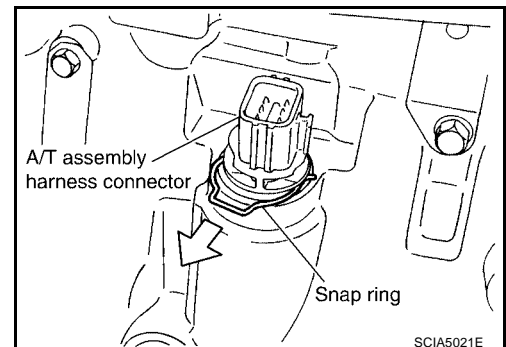

DISASSEMBLY

27. Push A/T assembly harness connector.

CAUTION:
Be careful not to damage connector.

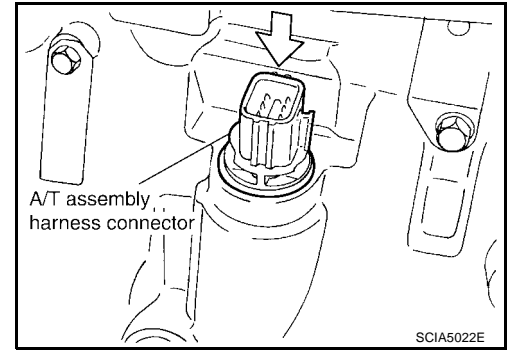

28. Remove oil pan and oil pan gasket.

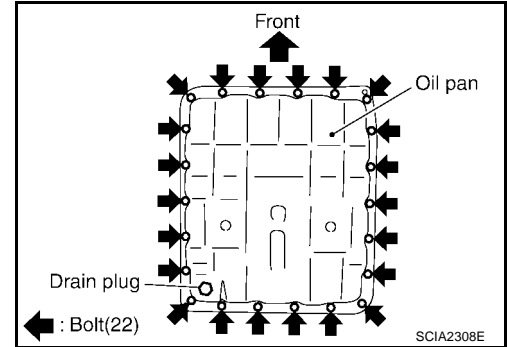

29. Check foreign materials in oil pan to help determine causes of malfunction. If the A/T fluid is very dark, smells burned, or contains foreign particles, the frictional material (clutches, band) may need replacement. A tacky film that will not wipe clean indicates varnish build up. Varnish can cause valves, servo, and clutches to stick and can inhibit pump pressure.

● If frictional material is detected, perform **A/T fluid cooler cleaning**. Refer to **AT-12, "A/T FLUID COOLER CLEANING PROCEDURE"**.

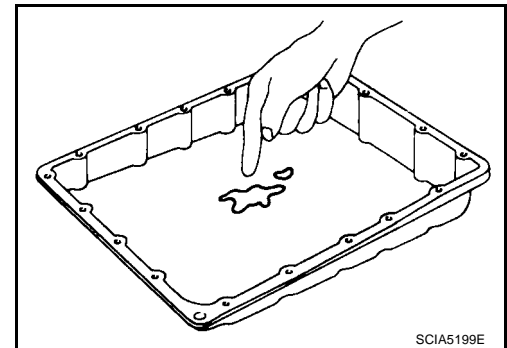

30. Remove magnets from oil pan.

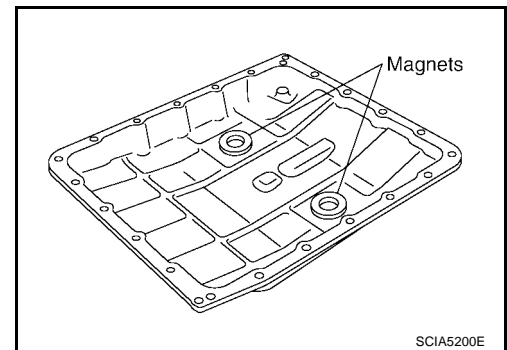

A
B
AT
D
E
F
G
H
I
J
K
L
M

DISASSEMBLY

31. Disconnect A/T fluid temperature sensor 2 connector.

CAUTION:
Be careful not to damage connector.

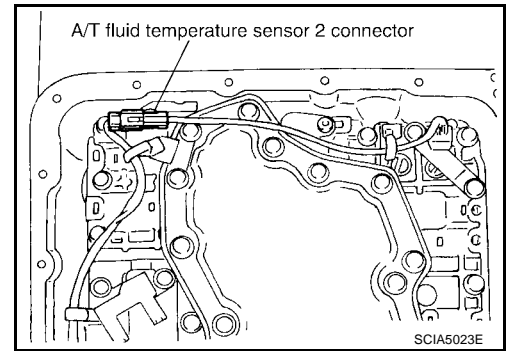

32. Straighten terminal clip to free A/T fluid temperature sensor 2 harness.

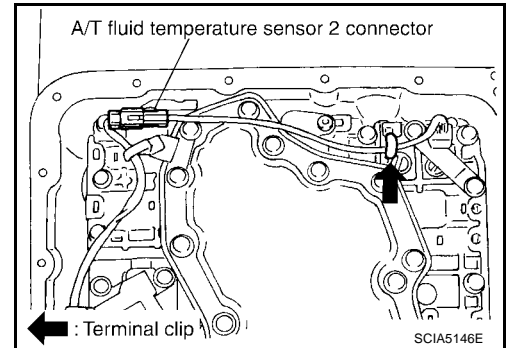

33. Disconnect revolution sensor connector.

CAUTION:
Be careful not to damage connector.

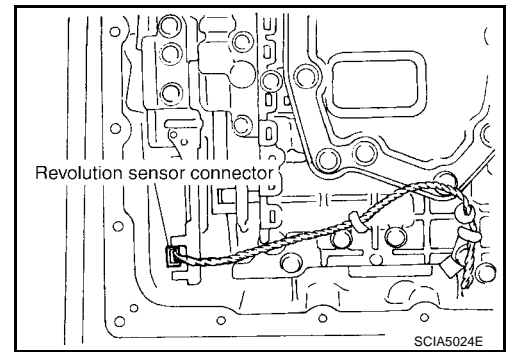

34. Straighten terminal clips to free revolution sensor harness.

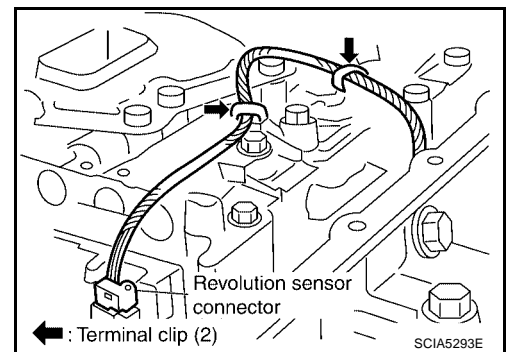

35. Remove bolts A, B and C from control valve with TCM.

Bolt symbol	Length mm (in)	Number of bolts
A	42 (1.65)	5
B	55 (2.17)	6
C	40 (1.57)	1

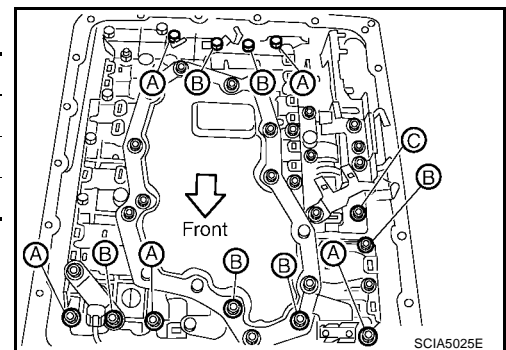

DISASSEMBLY

36. Remove control valve with TCM from transmission case.

CAUTION:

When removing, be careful with transmission assembly terminal connector and the manual valve notch and manual plate height. Remove it vertically.

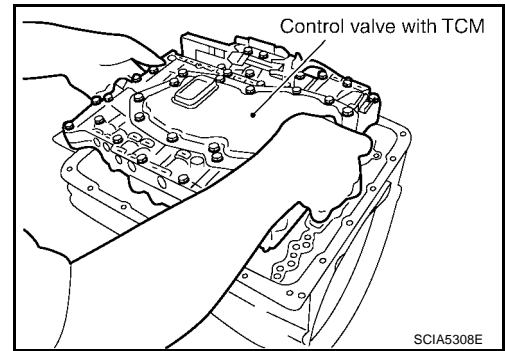

37. Remove A/T fluid temperature sensor 2 with bracket from control valve with TCM.

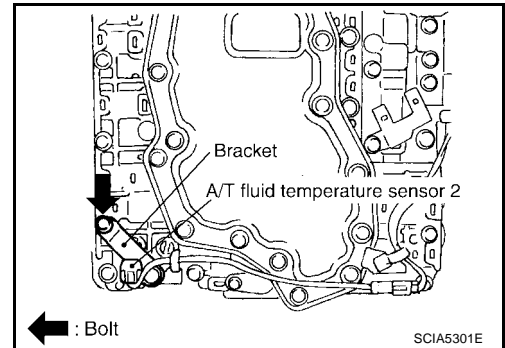

38. Remove bracket from A/T fluid temperature sensor 2.

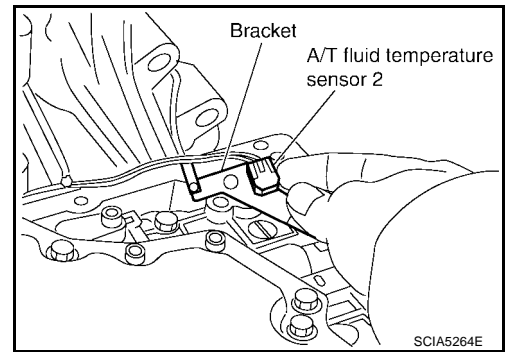

39. Remove O-ring from A/T assembly harness connector.

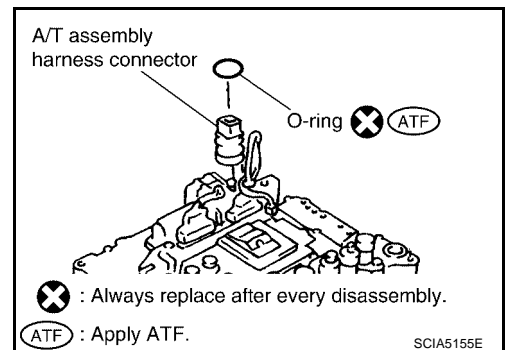

40. Remove rear extension assembly (2WD models) or adapter case assembly (4WD models) according to the following procedures.

A
B
AT
D
E
F
G
H
I
J
K
L
M

DISASSEMBLY

a. 2WD models

- i. Remove tightening bolts for rear extension assembly and transmission case.
- ii. Remove bracket.

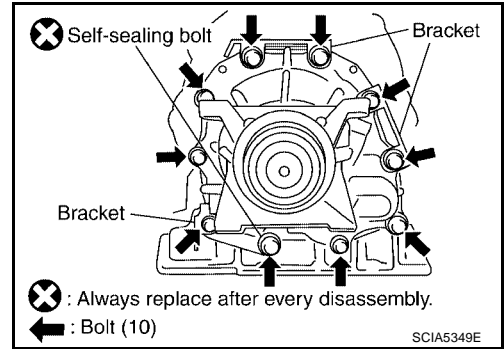

- iii. Tap rear extension assembly with soft hammer.

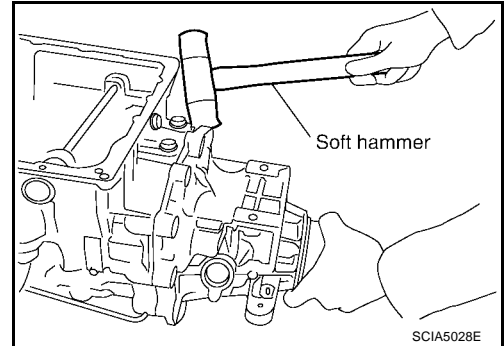

- iv. Remove rear extension assembly from transmission case. (With needle bearing)

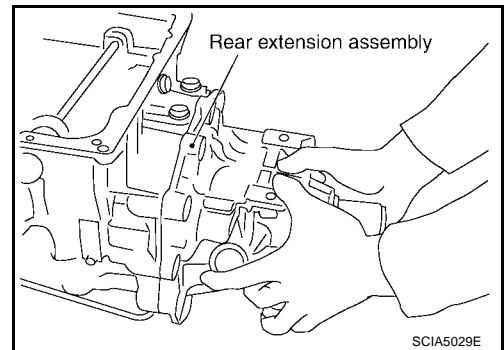

b. 4WD models

- i. Remove tightening bolts for adapter case assembly and transmission case.
- ii. Remove bracket.

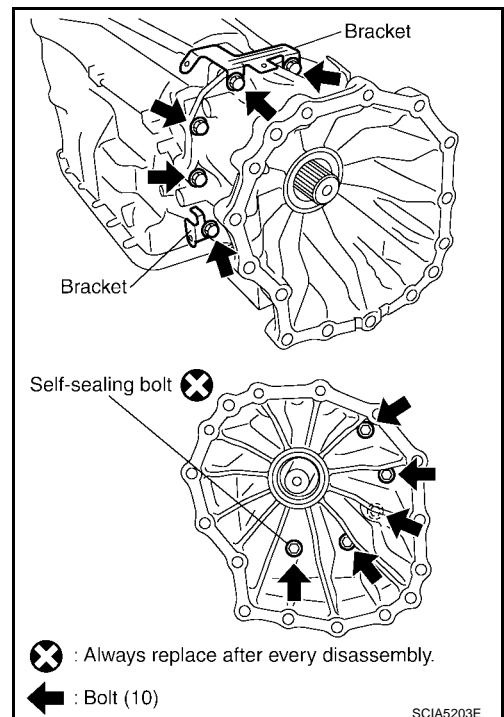

DISASSEMBLY

- iii. Tap adapter case assembly with soft hammer.
- iv. Remove adapter case assembly from transmission case. (With needle bearing)

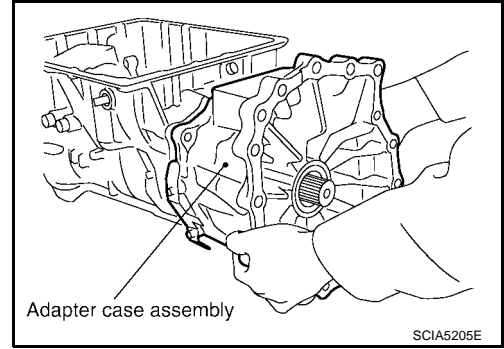

- v. Remove gasket from transmission case.

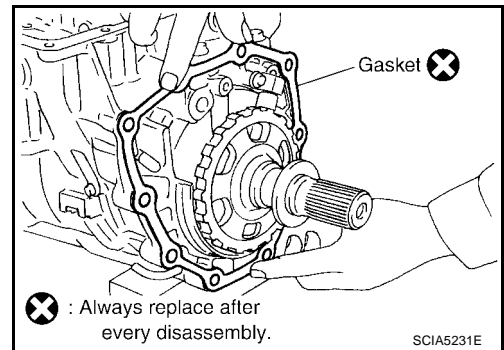

- 41. Remove bearing race from output shaft.

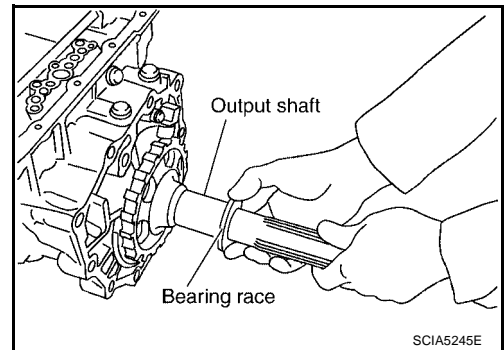

- 42. Remove output shaft from transmission case by rotating left/right.

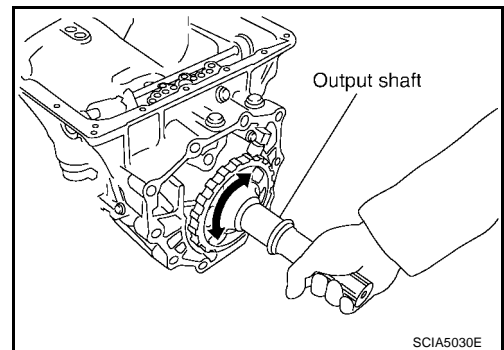

A
B
AT
D
E
F
G
H
I
J
K
L
M

DISASSEMBLY

43. Remove parking gear from output shaft.

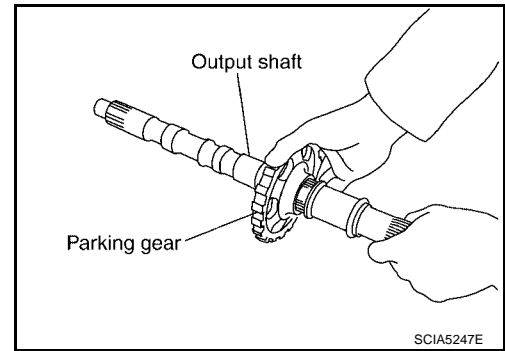

44. Remove seal rings from output shaft.

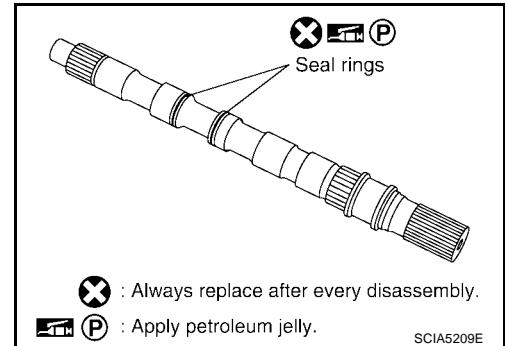

45. Remove needle bearing from transmission case.

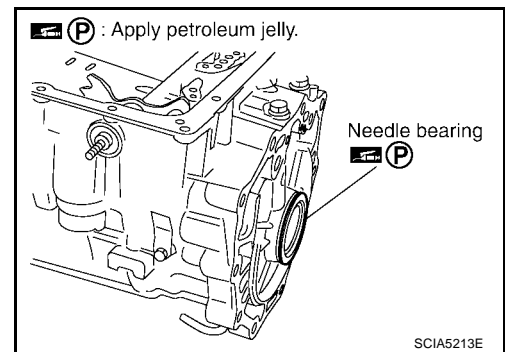

46. Remove revolution sensor from transmission case.

CAUTION:

- Do not subject it to impact by dropping or hitting it.
- Be careful not to damage harness with the edge of case.
- Do not allow metal filings, etc., to get on the sensor's front edge magnetic area.
- Do not place in an area affected by magnetism.

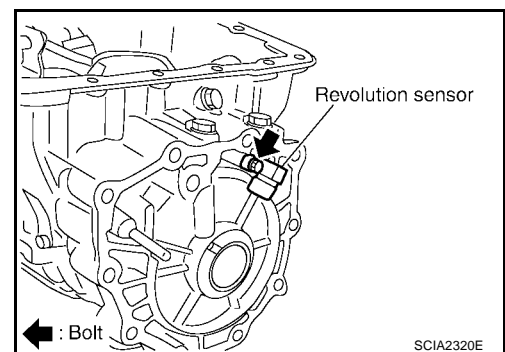

47. Remove reverse brake snap ring (fixing plate) using 2 flat-bladed screwdrivers.

NOTE:

Press out snap ring from the transmission case oil pan side gap using a flat-bladed screwdriver, and remove it using another screwdriver.

48. Remove reverse brake retaining plate from transmission case.

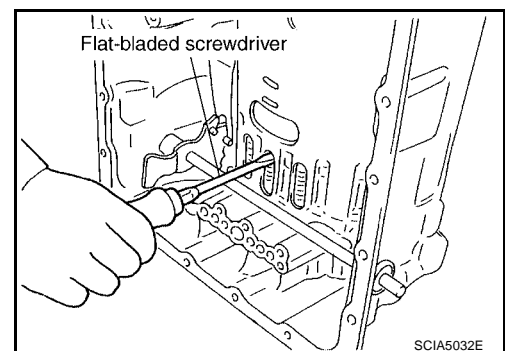

DISASSEMBLY

49. Remove N-spring from transmission case.

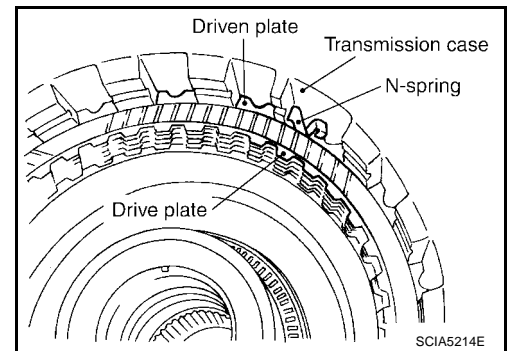

50. Remove reverse brake drive plates, driven plates and dish plate from transmission case.

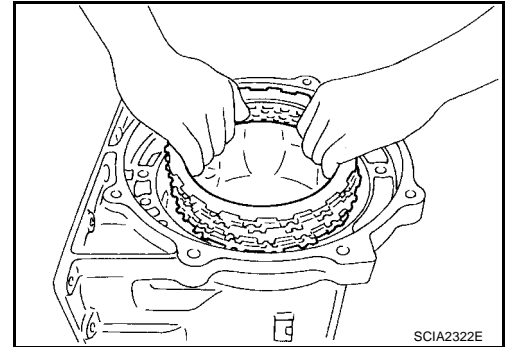

51. Remove snap ring (fixing spring retainer) from transmission case while compressing return spring, using Tool.

Tool number : KV31102400 (J-34285, J-34285-87)

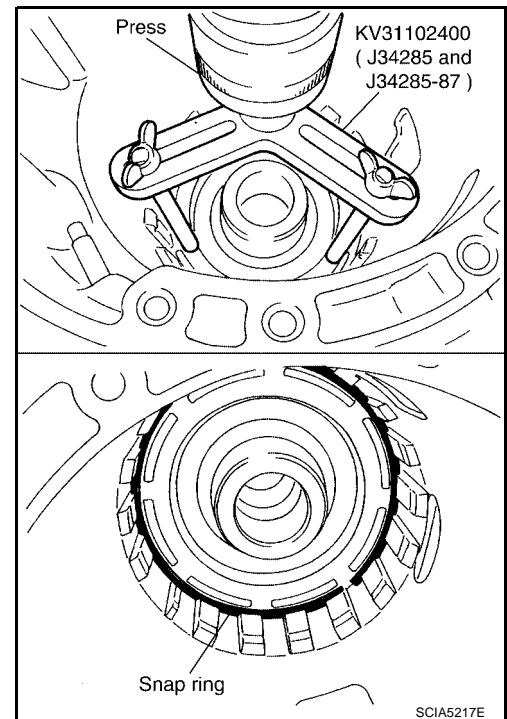

52. Remove spring retainer and return spring from transmission case.

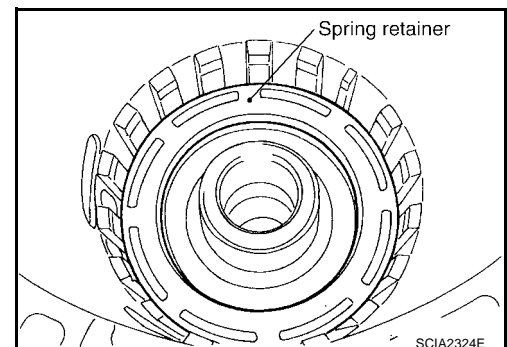

A
B
AT
D
E
F
G
H
I
J
K
L
M

DISASSEMBLY

53. Remove seal rings from drum support.

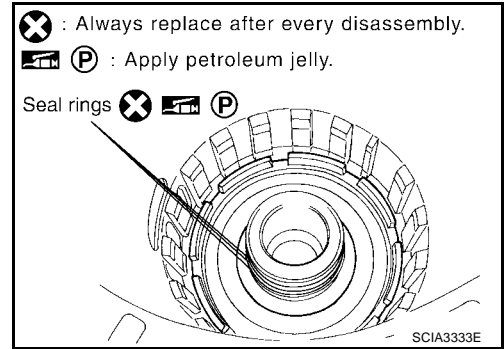

54. Remove needle bearing from drum support edge surface.

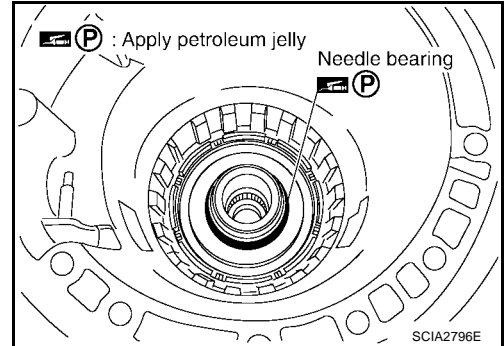

55. Remove reverse brake piston from transmission case with compressed air. Refer to [AT-279, "Oil Channel"](#) .

CAUTION:

Care should be taken not to abruptly blow air. It makes pistons incline, as the result, it becomes hard to disassemble the pistons.

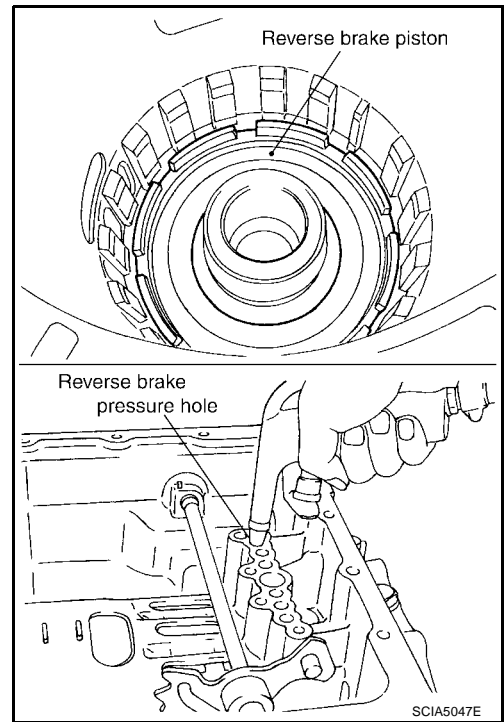

56. Remove D-rings from reverse brake piston.

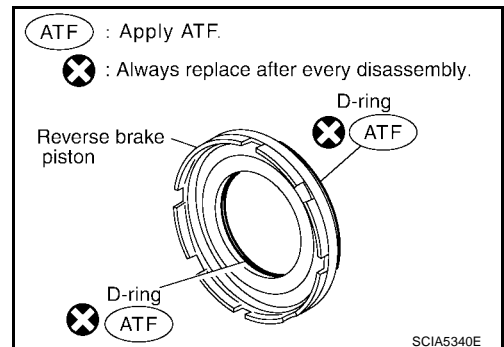

DISASSEMBLY

57. Use a pin punch (4mm dia. commercial service tool) to knock out retaining pin.

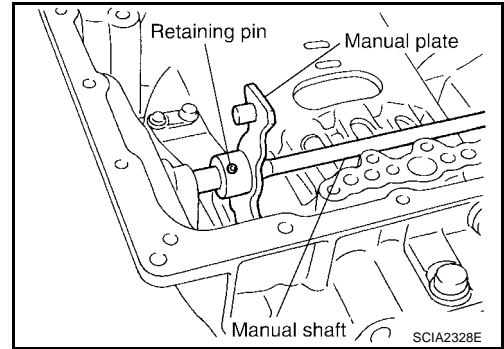

A

B

AT

58. Remove manual shaft retaining pin with pliers.

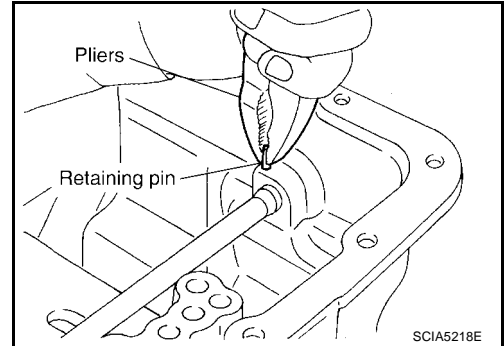

D

E

F

G

59. Remove manual plate (with parking rod) from manual shaft.

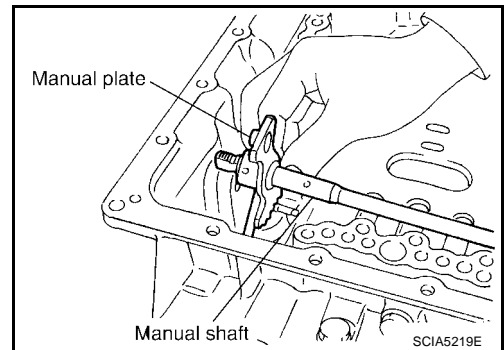

H

I

J

K

60. Remove parking rod from manual plate.
61. Remove manual shaft from transmission case.

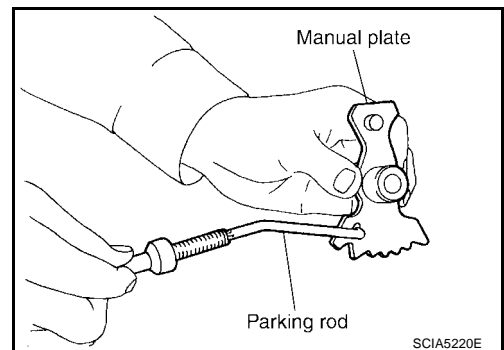

L

M

62. Remove manual shaft oil seals using a flat-bladed screwdriver.
CAUTION:
Be careful not to scratch transmission case.

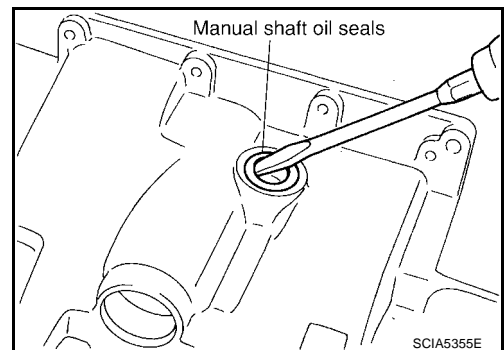

DISASSEMBLY

63. Remove detent spring and spacer from transmission case.

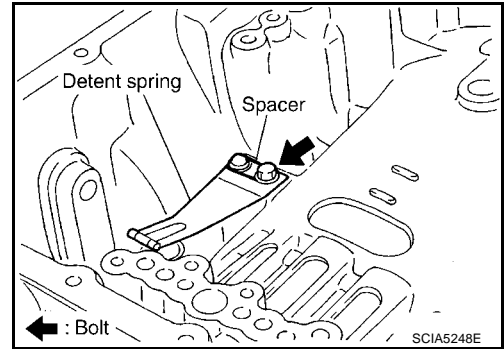

64. Using snap ring pliers, remove snap ring from transmission case.

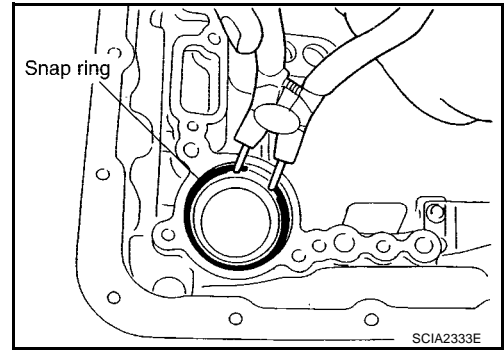

65. Remove servo assembly (with return spring) from transmission case.

66. Remove return spring from servo assembly.

67. Remove O-rings from servo assembly.

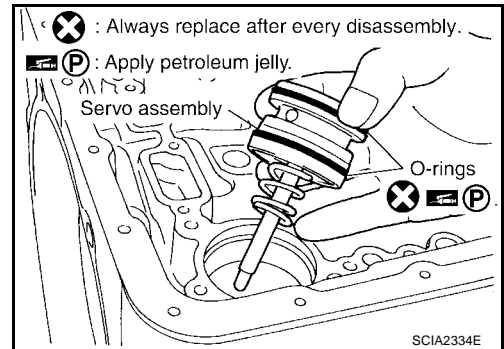

68. Remove parking actuator support from rear extension (2WD models) or adapter case (4WD models).

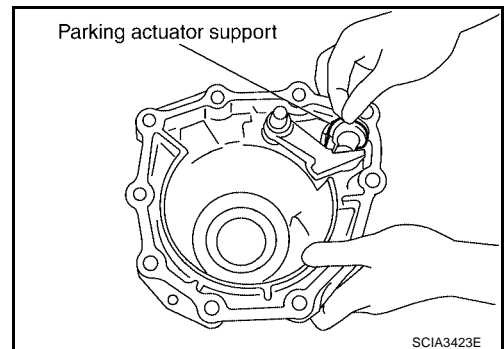

DISASSEMBLY

69. Remove parking pawl (with return spring) and pawl shaft from rear extension (2WD models) or adapter case (4WD models).

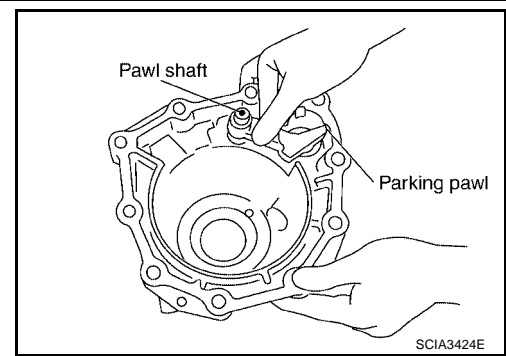

70. Remove return spring from parking pawl.

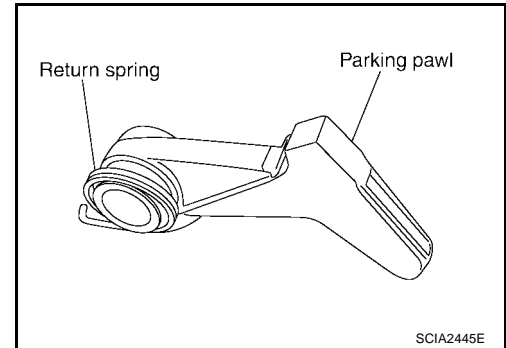

71. Remove needle bearing from rear extension (2WD models) or adapter case (4WD models).

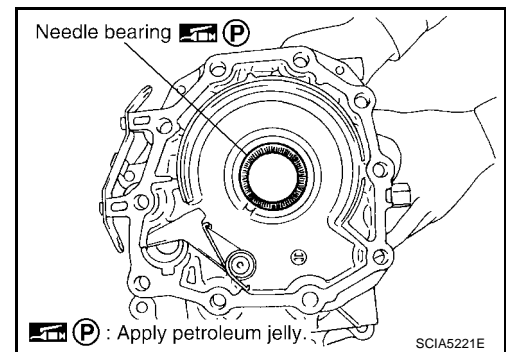

72. Remove rear oil seal from rear extension (2WD models) or adapter case (4WD models).

CAUTION:

Be careful not to scratch rear extension (2WD models) or adapter case (4WD models).

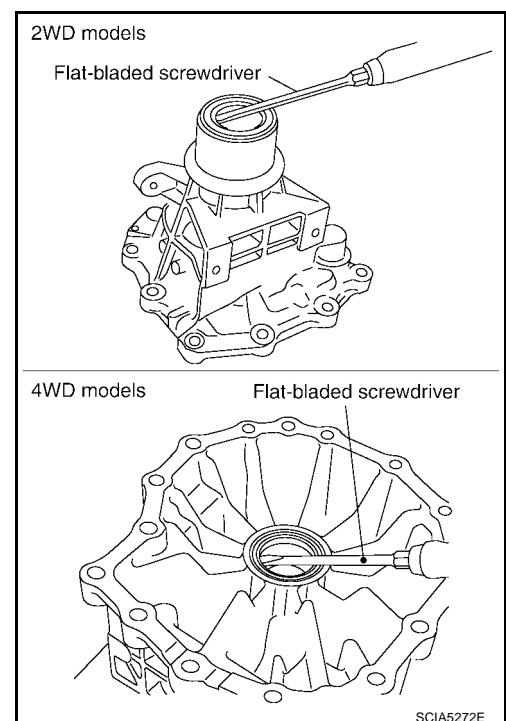

A
B
AT
D
E
F
G
H
I
J
K
L
M

REPAIR FOR COMPONENT PARTS

PPF:00000

ECS00CCX

REPAIR FOR COMPONENT PARTS

Oil Pump COMPONENTS

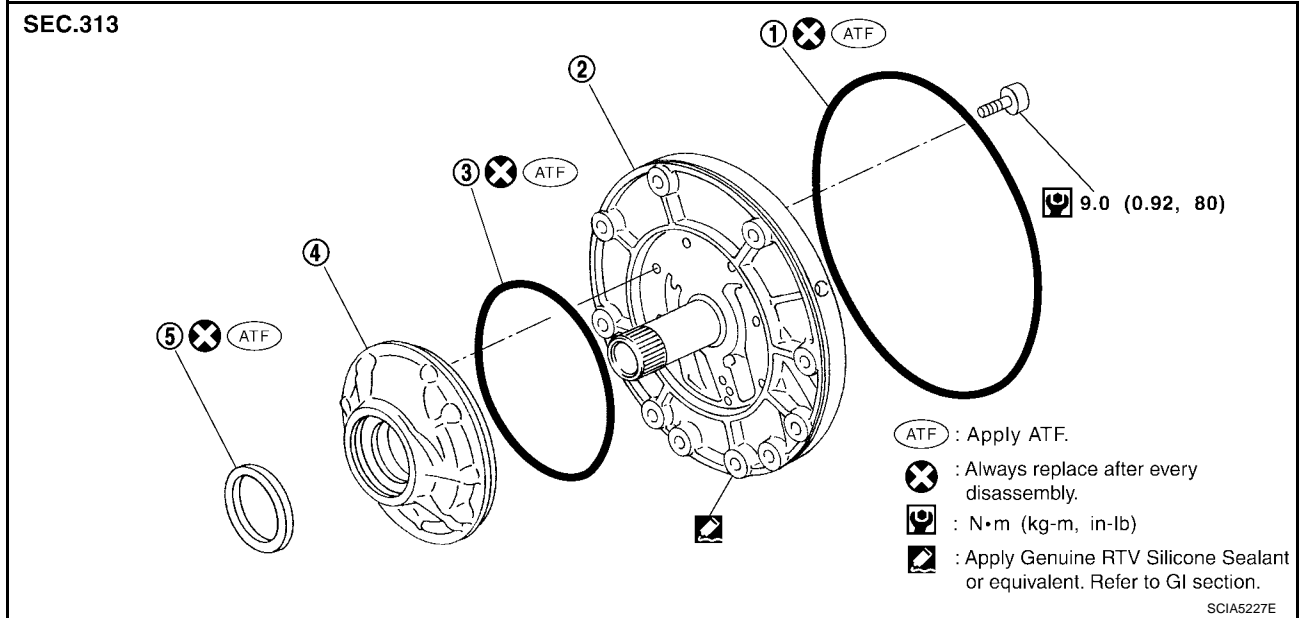

1. O-ring
2. Oil pump cover
3. O-ring
4. Oil pump housing
5. Oil pump housing oil seal

DISASSEMBLY

1. Remove oil pump housing from oil pump cover.

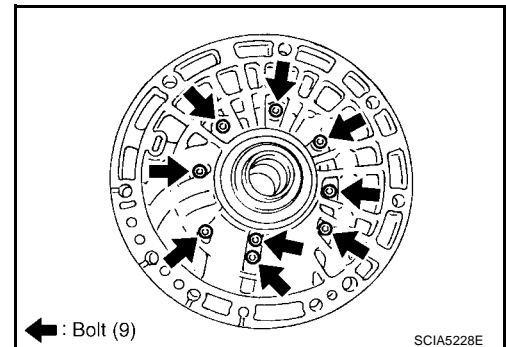

2. Remove oil pump housing oil seal using a flat-bladed screwdriver.

CAUTION:

Be careful not to scratch oil pump housing.

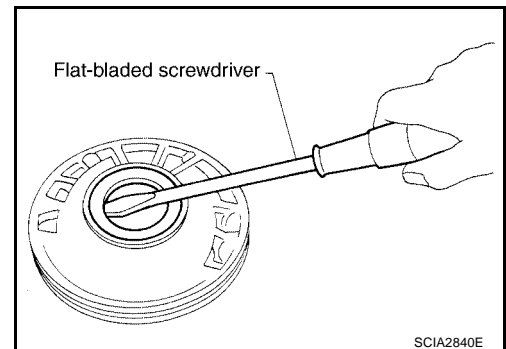

REPAIR FOR COMPONENT PARTS

3. Remove O-ring from oil pump housing.

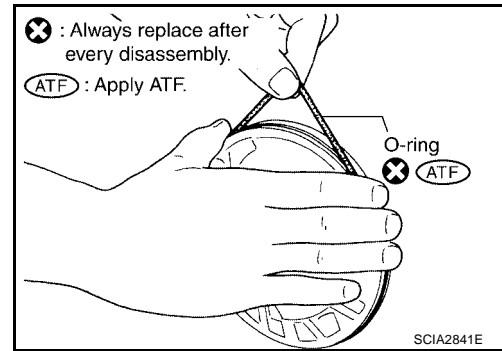

4. Remove O-ring from oil pump cover.

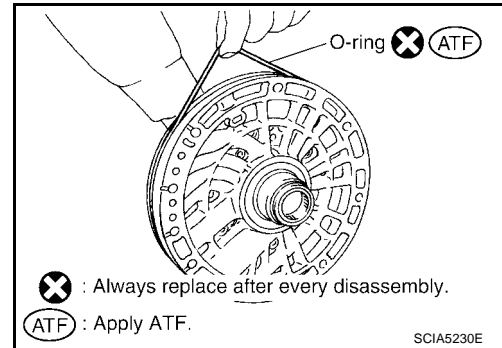

ASSEMBLY

1. Install O-ring to oil pump cover.

CAUTION:

- Do not reuse O-ring.
- Apply ATF to O-ring.

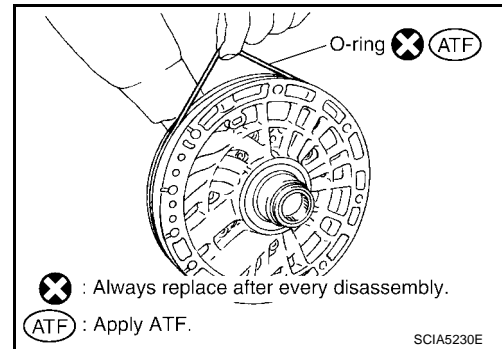

2. Install O-ring to oil pump housing.

CAUTION:

- Do not reuse O-ring.
- Apply ATF to O-ring.

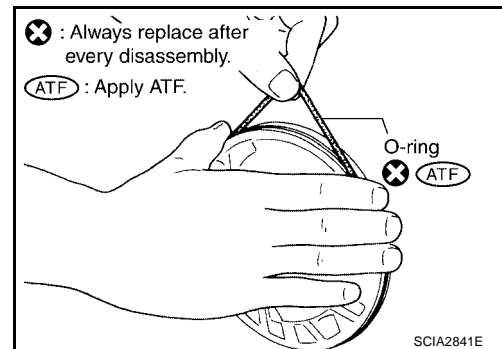

A

B

AT

D

E

F

G

H

I

J

K

L

M

REPAIR FOR COMPONENT PARTS

3. Install oil pump housing oil seal to the oil pump housing until it is flush.

Tool number : ST33400001 (J-26082)

CAUTION:

- Do not reuse oil seal.
- Apply ATF to oil seal.

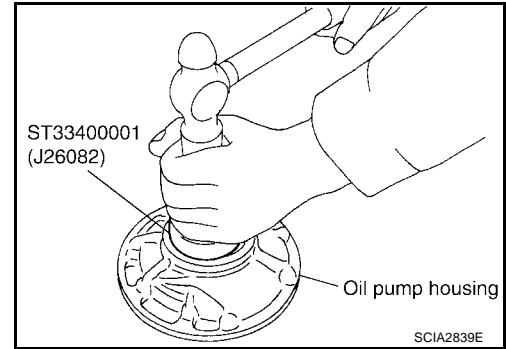

4. Install oil pump housing in oil pump cover. Tighten oil pump housing fitting bolt to the specified torque. Refer to [AT-271](#). "[Components](#)".

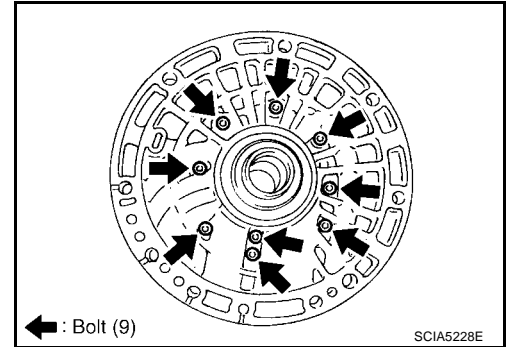

Front Sun Gear, 3rd One-Way Clutch COMPONENTS

ECS00CCY

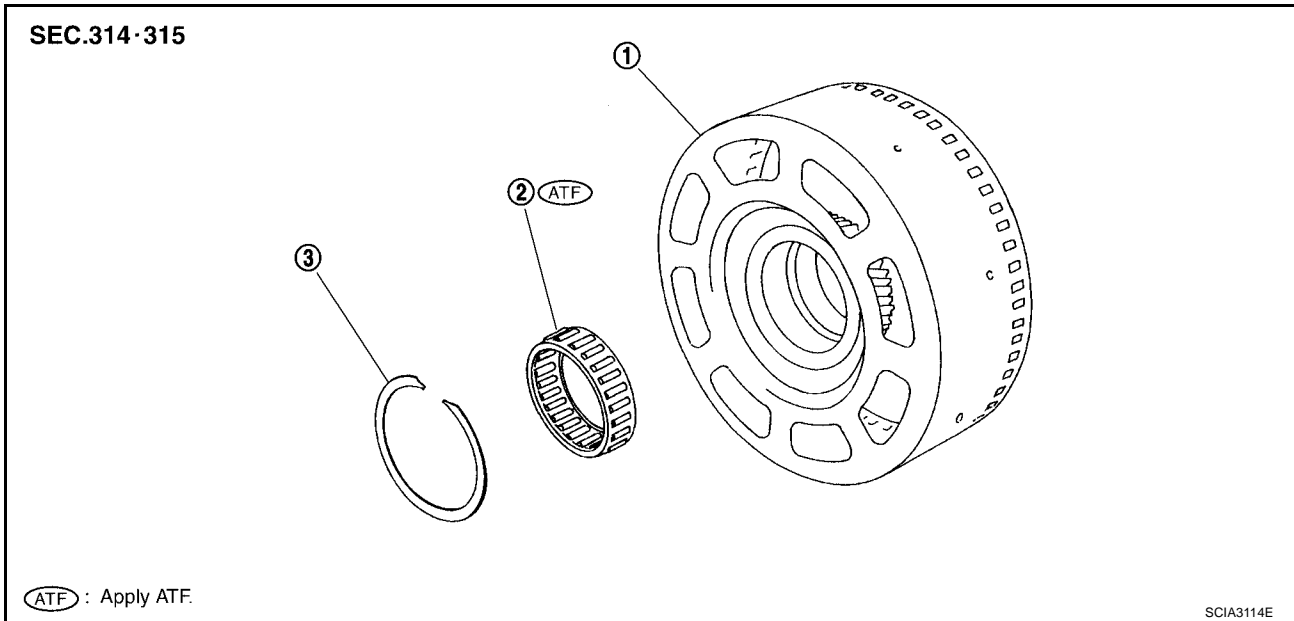

1. Front sun gear

2. 3rd one-way clutch

3. Snap ring

REPAIR FOR COMPONENT PARTS

DISASSEMBLY

1. Using a flat-bladed screwdriver, remove snap ring from front sun gear.

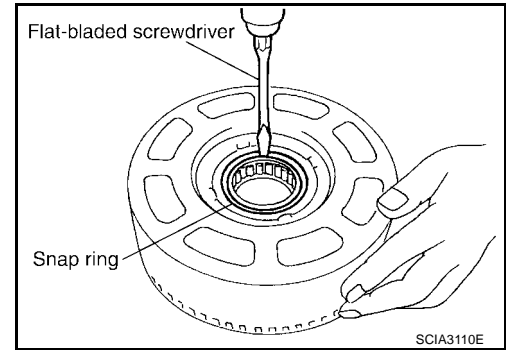

2. Remove 3rd one-way clutch from front sun gear.

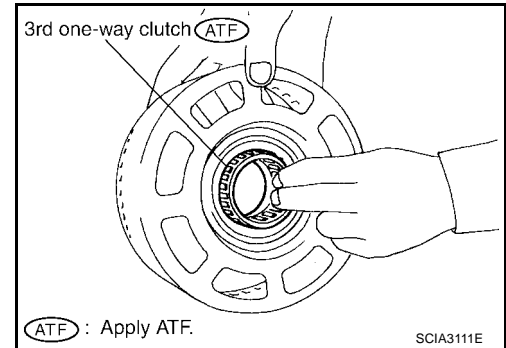

INSPECTION

3rd One-way Clutch

- Check frictional surface for wear or damage.

CAUTION:

If necessary, replace the 3rd one-way clutch.

Front Sun Gear Snap Ring

- Check for deformation, fatigue or damage.

CAUTION:

If necessary, replace the snap ring.

Front Sun Gear

- Check for deformation, fatigue or damage.

CAUTION:

If necessary, replace the front sun gear.

ASSEMBLY

1. Install 3rd one-way clutch in front sun gear.

CAUTION:

Apply ATF to 3rd one-way clutch.

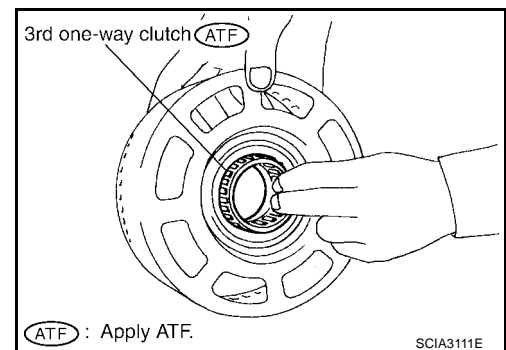

A
B
AT
D
E
F
G
H
I
J
K
L
M

REPAIR FOR COMPONENT PARTS

2. Using a flat-bladed screwdriver, install snap ring in front sun gear.

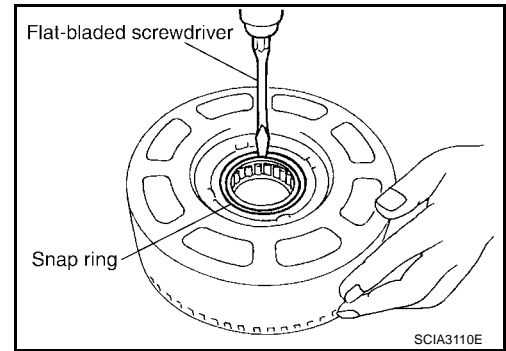

3. Check operation of 3rd one-way clutch.
 - a. Hold oil pump assembly and turn front sun gear.
 - b. Check 3rd one-way clutch for correct locking and unlocking directions.

CAUTION:

If not as shown in illustration, check installation direction of 3rd one-way clutch.

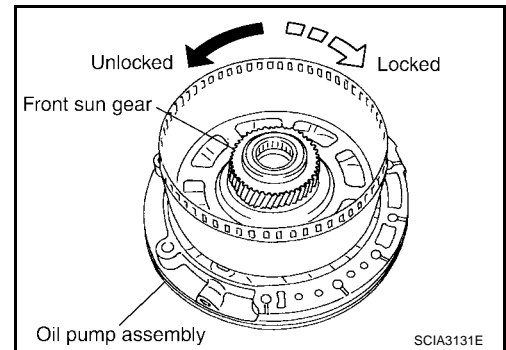

REPAIR FOR COMPONENT PARTS

Front Carrier, Input Clutch, Rear Internal Gear COMPONENTS

ECS00CCZ

A
B
AT
D
E
F
G
H
I
J
K
L
M

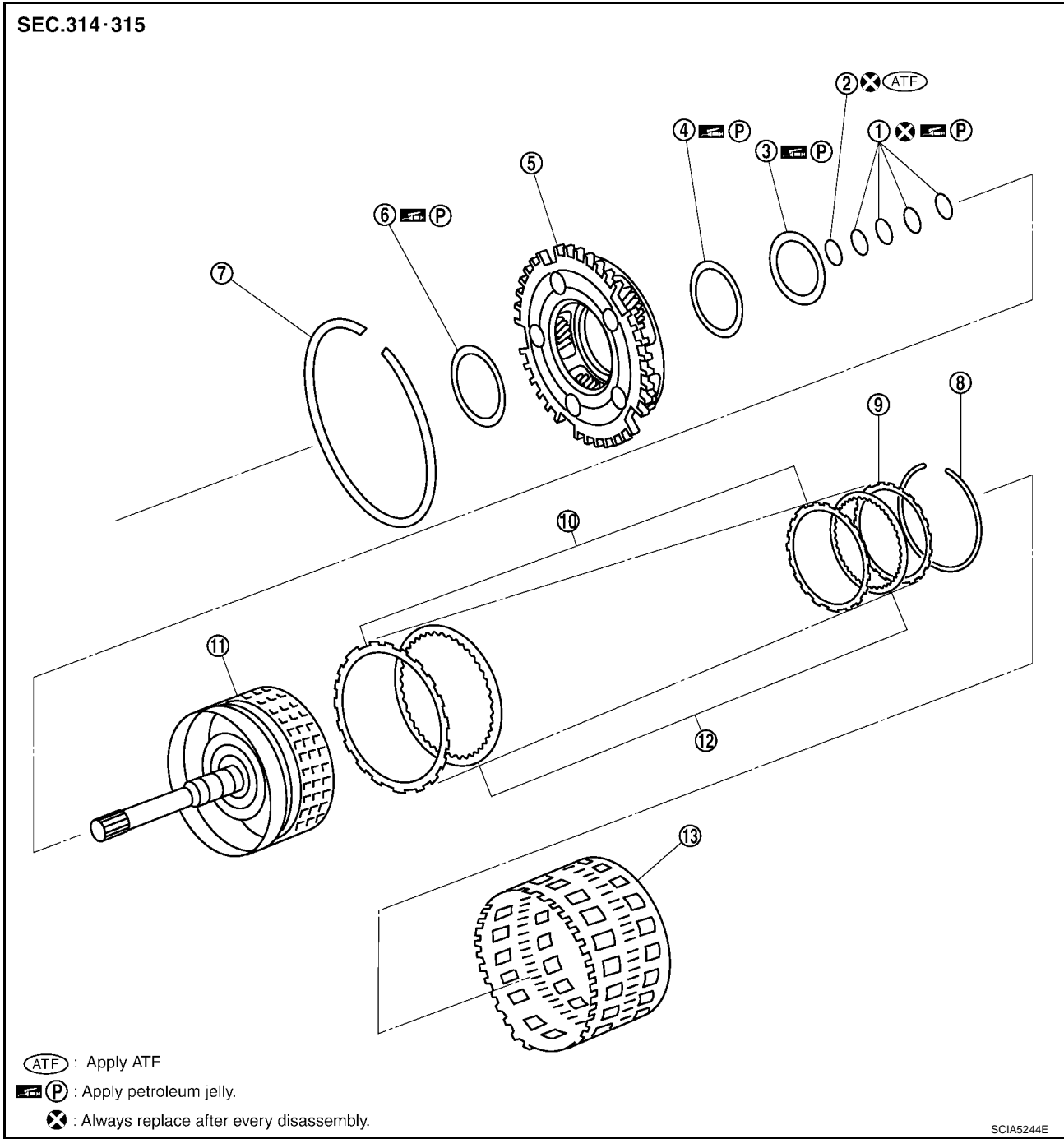

- | | | |
|------------------------|---------------------------|--------------------|
| 1. Seal ring | 2. O-ring | 3. Needle bearing |
| 4. Bearing race | 5. Front carrier assembly | 6. Needle bearing |
| 7. Snap ring | 8. Snap ring | 9. Retaining plate |
| 10. Driven plate | 11. Input clutch drum | 12. Drive plate |
| 13. Rear internal gear | | |

REPAIR FOR COMPONENT PARTS

DISASSEMBLY

1. Compress snap ring using 2 flat-bladed screwdrivers.
2. Remove front carrier assembly and input clutch assembly from rear internal gear.
3. Remove front carrier assembly from input clutch assembly.

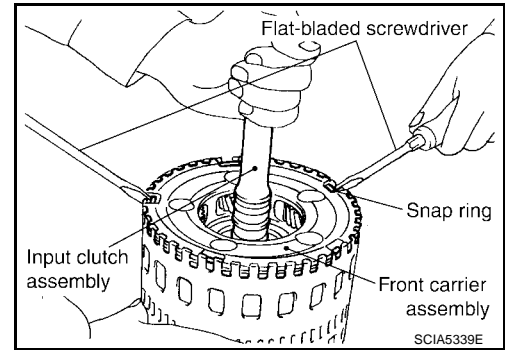

- a. Remove bearing race from front carrier assembly.

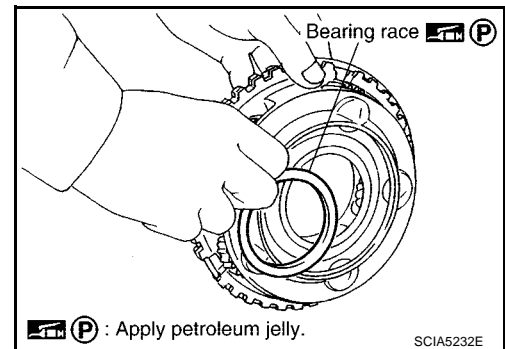

- b. Remove needle bearing from front carrier assembly.

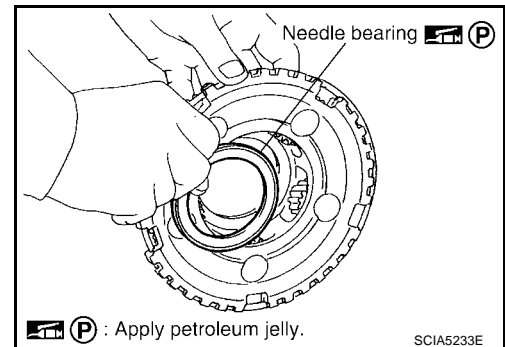

- c. Remove snap ring from front carrier assembly.

CAUTION:

Do not expand snap ring excessively.

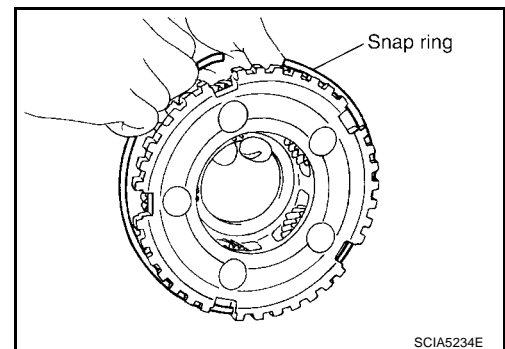

REPAIR FOR COMPONENT PARTS

4. Disassemble input clutch assembly.
 - a. Remove O-ring and seal rings from input clutch assembly.

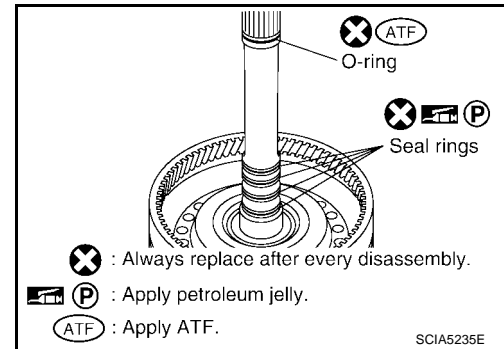

- b. Remove needle bearing from input clutch assembly.

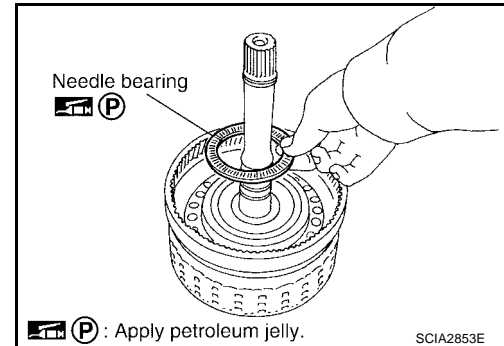

- c. Remove snap ring from input clutch drum, using flat-bladed screwdriver.
 - d. Remove drive plates, driven plates and retaining plate from input clutch drum.

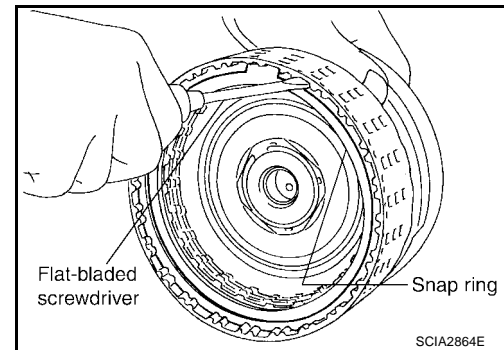

INSPECTION

Front Carrier Snap Ring

- Check for deformation, fatigue or damage.

CAUTION:

If necessary, replace the snap ring.

Input Clutch Snap Ring

- Check for deformation, fatigue or damage.

CAUTION:

If necessary, replace the input clutch assembly.

Input Clutch Drum

- Check for deformation, fatigue or damage or burns.

CAUTION:

If necessary, replace the input clutch assembly.

Input Clutch Drive Plates

- Check facing for burns, cracks or damage.

CAUTION:

If necessary, replace the input clutch assembly.

Input Clutch Retaining Plate and Driven Plates

- Check facing for burns, cracks or damage.

A
B
AT
D
E
F
G
H
I
J
K
L
M

REPAIR FOR COMPONENT PARTS

CAUTION:

If necessary, replace the input clutch assembly.

Front Carrier Assembly

- Check for deformation, fatigue or damage.

CAUTION:

If necessary, replace the front carrier assembly.

Rear Internal Gear

- Check for deformation, fatigue or damage.

CAUTION:

If necessary, replace the rear internal gear.

ASSEMBLY

1. Install input clutch.
 - a. Install drive plates, driven plates and retaining plate in input clutch drum.

CAUTION:

Take care with order of plates.

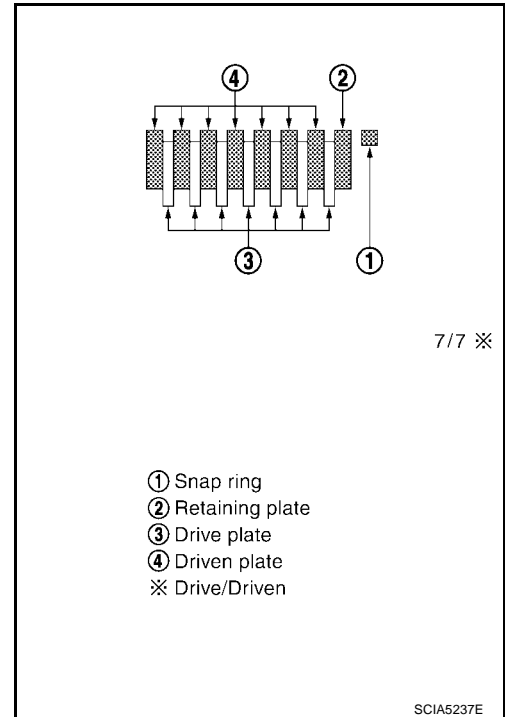

- b. Install snap ring in input clutch drum, using a flat-bladed screwdriver.

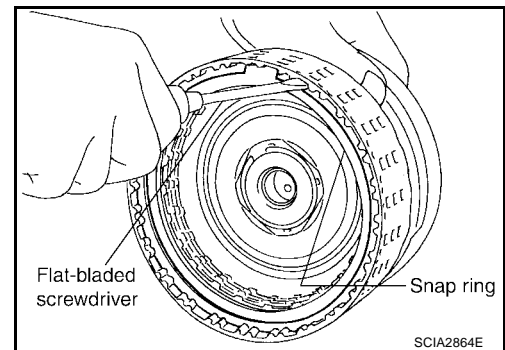

REPAIR FOR COMPONENT PARTS

- c. Install needle bearing in input clutch assembly.

CAUTION:

Apply petroleum jelly to needle bearing.

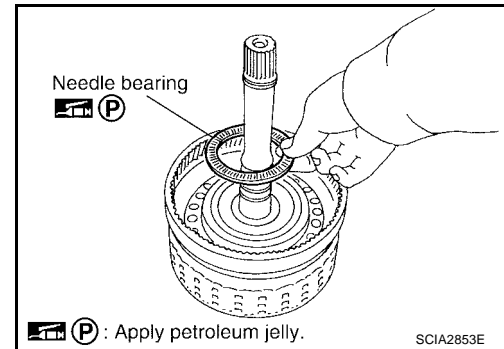

- d. Install new O-ring and seal rings in input clutch assembly.

CAUTION:

- Do not reuse O-ring and seal rings.
- Apply ATF to O-ring.
- Apply petroleum jelly to seal rings.

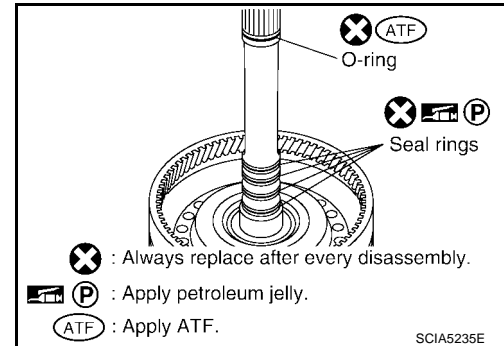

2. Install front carrier assembly.

- a. Install snap ring to front carrier assembly.

CAUTION:

Do not expand snap ring excessively.

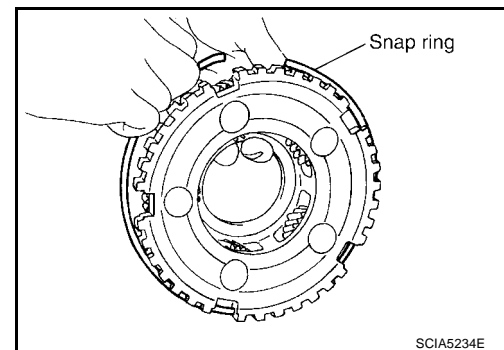

- b. Install needle bearing in front carrier assembly.

CAUTION:

- Take care with the direction of needle bearing. Refer to [AT-281, "Locations of Adjusting Shims, Needle Bearings, Thrust Washers and Snap Rings"](#).
- Apply petroleum jelly to needle bearing.

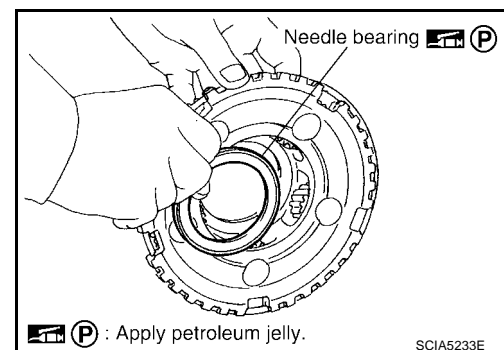

- c. Install bearing race in front carrier assembly.

CAUTION:

Apply petroleum jelly to bearing race.

- d. Install front carrier assembly to input clutch assembly.

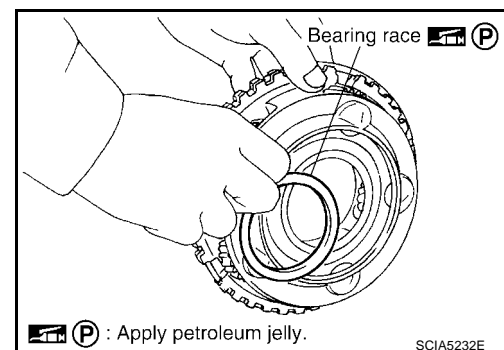

A
B
AT
D
E
F
G
H
I
J
K
L
M

REPAIR FOR COMPONENT PARTS

- Compress snap ring using 2 flat-bladed screwdrivers.
- Install front carrier assembly and input clutch assembly to rear internal gear.

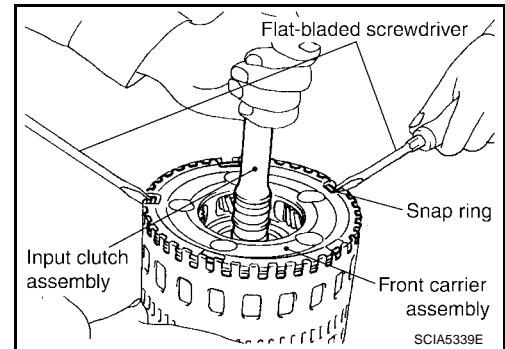

Mid Sun Gear, Rear Sun Gear, High and Low Reverse Clutch Hub COMPONENTS

ECS00CDO

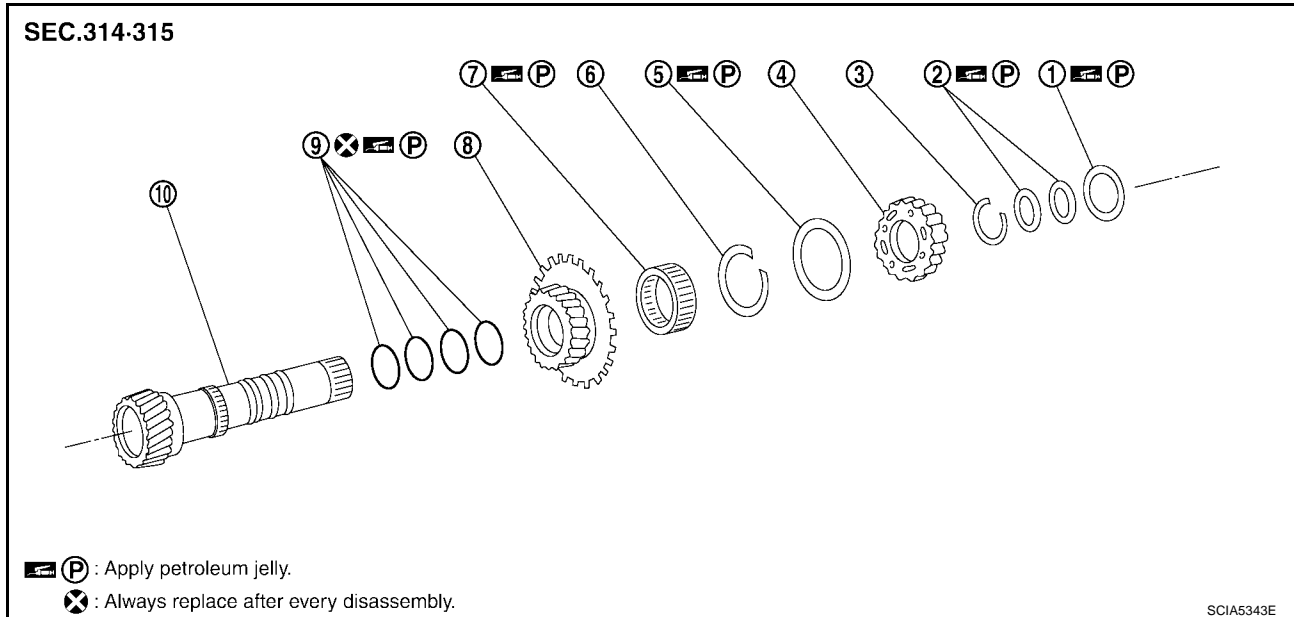

- | | | |
|------------------------------------|-------------------|--------------|
| 1. Needle bearing | 2. Bearing race | 3. Snap ring |
| 4. High and low reverse clutch hub | 5. Needle bearing | 6. Snap ring |
| 7. 1st one-way clutch | 8. Rear sun gear | 9. Seal ring |
| 10. Mid sun gear | | |

DISASSEMBLY

- Remove needle bearing and bearing races from high and low reverse clutch hub.

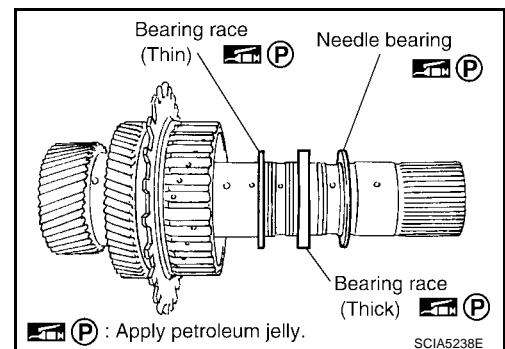

REPAIR FOR COMPONENT PARTS

- Using a snap ring pliers, remove snap ring from mid sun gear assembly.

CAUTION:

Do not expand snap ring excessively.

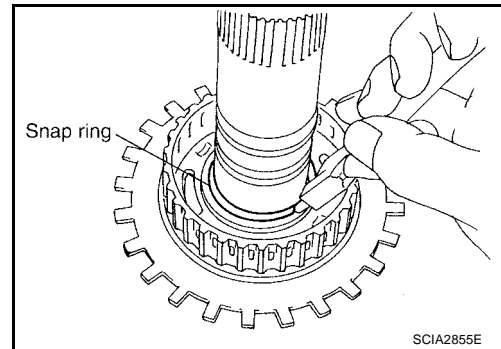

- Remove high and low reverse clutch hub from mid sun gear assembly.

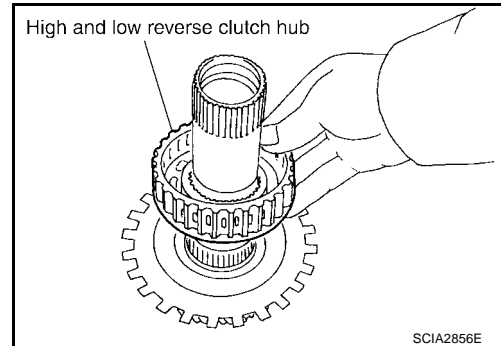

- Remove needle bearing from high and low reverse clutch hub.

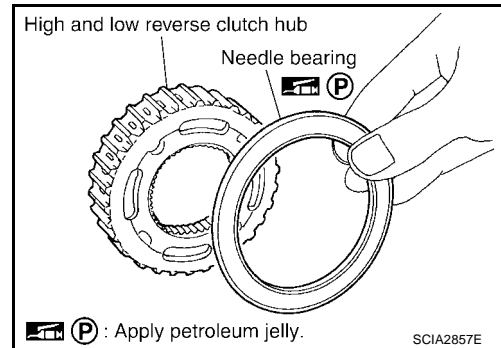

- Remove rear sun gear assembly from mid sun gear assembly.

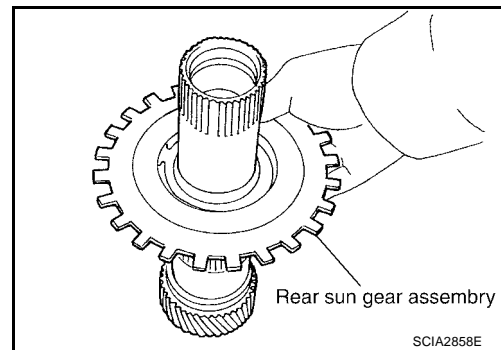

A

B

AT

D

E

F

G

H

I

J

K

L

M

REPAIR FOR COMPONENT PARTS

- a. Using a flat-bladed screwdriver, remove snap ring from rear sun gear.

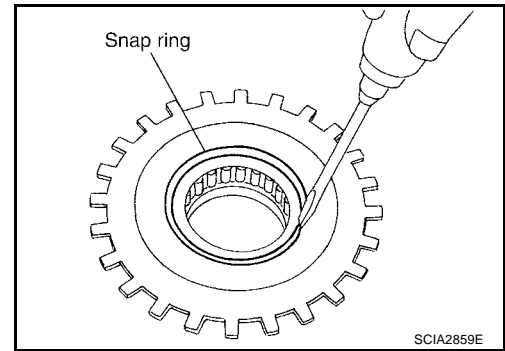

- b. Remove 1st one-way clutch from rear sun gear.

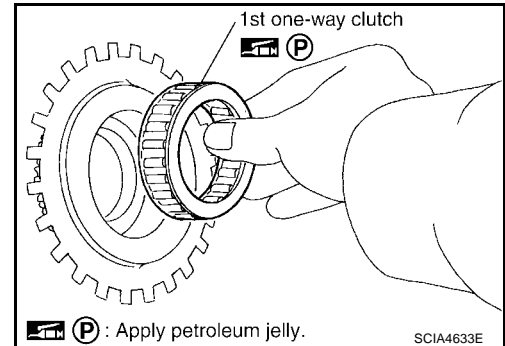

5. Remove seal rings from mid sun gear.

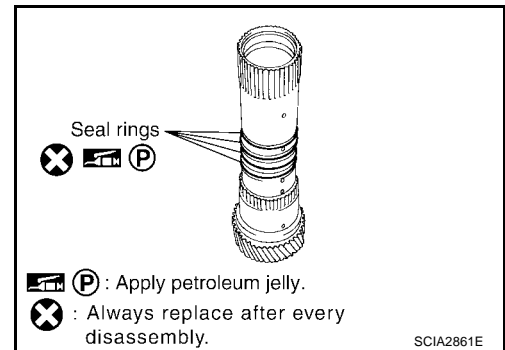

INSPECTION

High and Low Reverse Clutch Hub Snap Ring, Rear Sun Gear Snap Ring

- Check for deformation, fatigue or damage.

CAUTION:

If necessary, replace the snap ring.

1st One-way Clutch

- Check frictional surface for wear or damage.

CAUTION:

If necessary, replace the 1st one-way clutch.

Mid Sun Gear

- Check for deformation, fatigue or damage.

CAUTION:

If necessary, replace the mid sun gear.

Rear Sun Gear

- Check for deformation, fatigue or damage.

CAUTION:

If necessary, replace the rear sun gear.

High and Low Reverse Clutch Hub

- Check for deformation, fatigue or damage.

REPAIR FOR COMPONENT PARTS

CAUTION:

If necessary, replace the high and low reverse clutch hub.

ASSEMBLY

1. Install seal rings from mid sun gear.

CAUTION:

- Do not reuse seal rings.
- Apply petroleum jelly to seal rings.

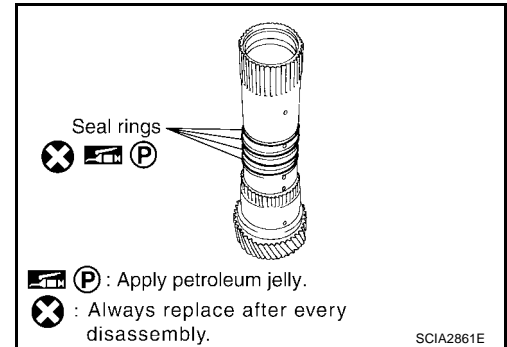

2. Install 1st one-way clutch to rear sun gear.

CAUTION:

Apply petroleum jelly to 1st one-way clutch.

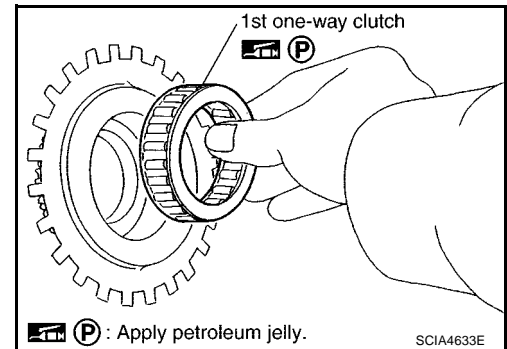

3. Using a flat-bladed screwdriver, install snap ring to rear sun gear.

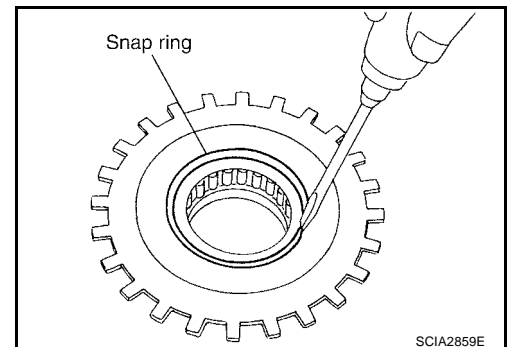

4. Install rear sun gear assembly to mid sun gear assembly.

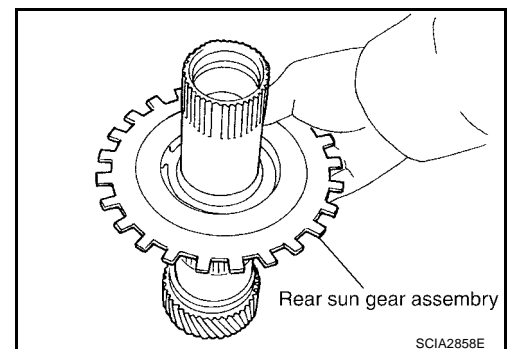

A

B

AT

D

E

F

G

H

I

J

K

L

M

REPAIR FOR COMPONENT PARTS

5. Install needle bearing to high and low reverse clutch hub.

CAUTION:

- Take care with the direction of needle bearing. Refer to [AT-281, "Locations of Adjusting Shims, Needle Bearings, Thrust Washers and Snap Rings"](#).
- Apply petroleum jelly to needle bearing.

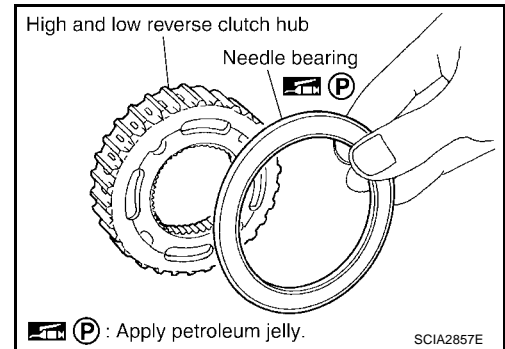

6. Install high and low reverse clutch hub to mid sun gear assembly.

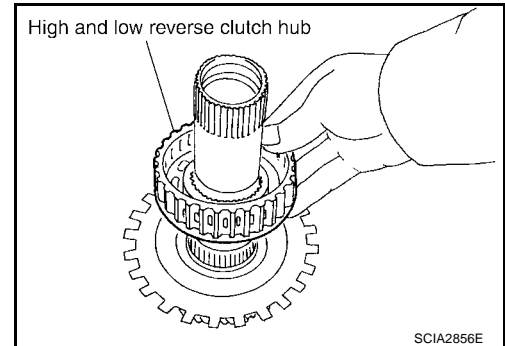

7. Using a snap ring pliers, install snap ring to mid sun gear assembly.

CAUTION:

Do not expand snap ring excessively.

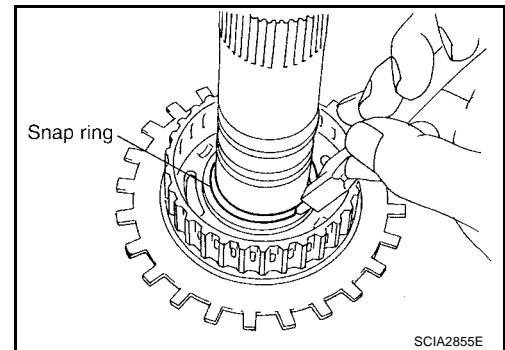

8. Check operation of 1st one-way clutch.

- Hold mid sun gear and turn rear sun gear.
- Check 1st one-way clutch for correct locking and unlocking directions.

CAUTION:

If not as shown in illustration, check installation direction of 1st one-way clutch.

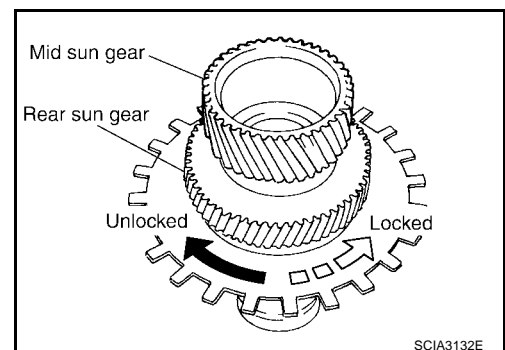

9. Install needle bearing and bearing races to high and low reverse clutch hub.

CAUTION:

- Apply petroleum jelly to needle bearing and bearing races.
- Take care with order of bearing races.

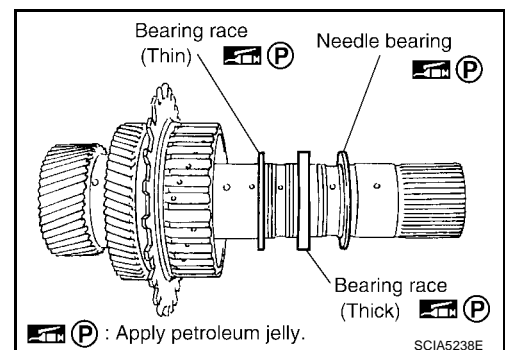

REPAIR FOR COMPONENT PARTS

High and Low Reverse Clutch COMPONENTS

ECS00CD1

A

B

AT

D

E

F

G

H

I

J

K

L

M

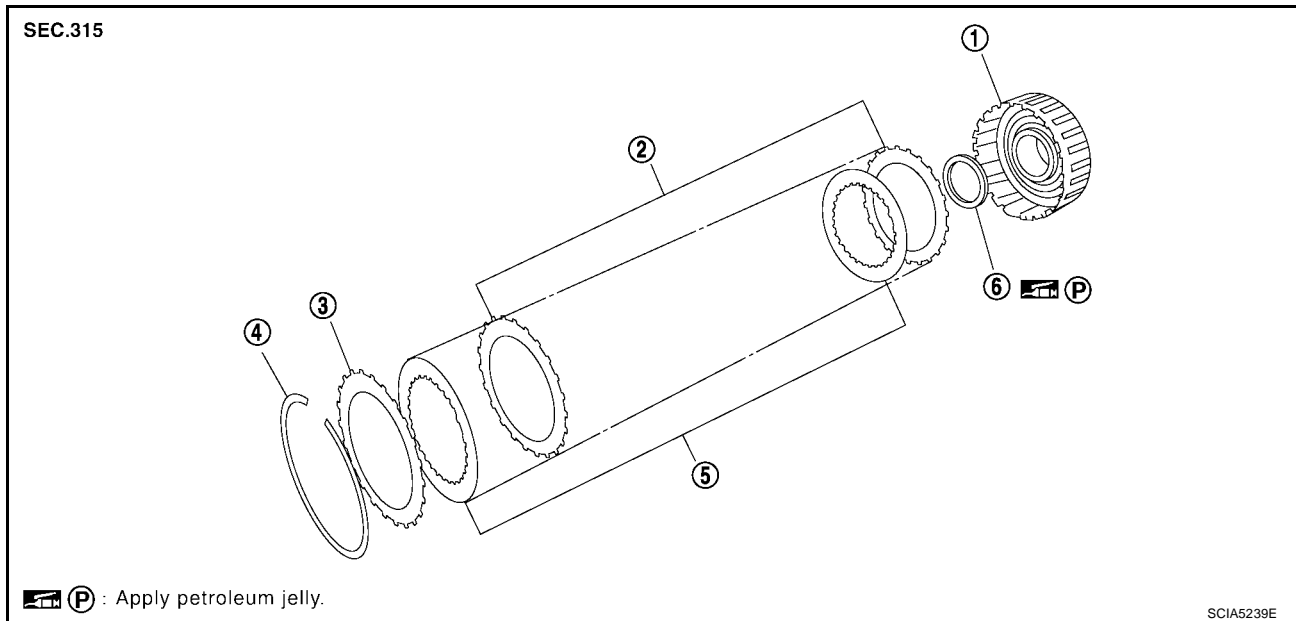

- | | | |
|-------------------------------------|-----------------|--------------------|
| 1. High and low reverse clutch drum | 2. Driven plate | 3. Retaining plate |
| 4. Snap ring | 5. Drive plate | 6. Bearing race |

DISASSEMBLY

1. Remove bearing race from high and low reverse clutch drum.

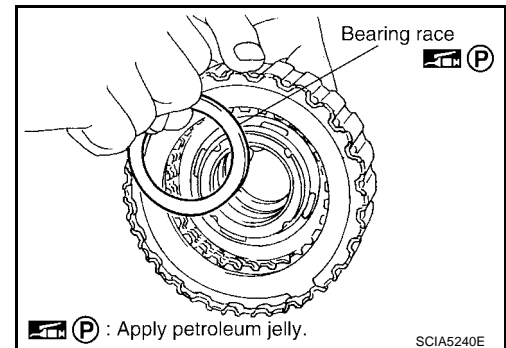

2. Using a flat-bladed screwdriver, remove snap ring from high and low reverse clutch drum.
3. Remove drive plates, driven plates and retaining plate from high and low reverse clutch drum.

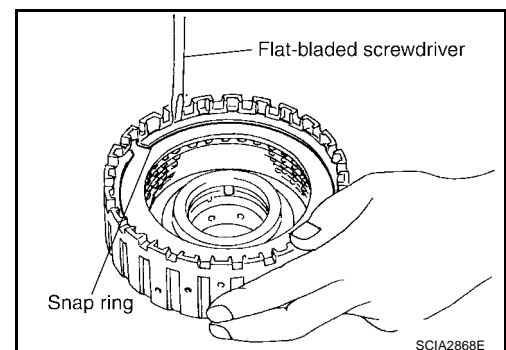

INSPECTION

- Check the following, and replace high and low reverse clutch assembly if necessary.

High and Low Reverse Clutch Snap Ring

- Check for deformation, fatigue or damage.

High and Low Reverse Clutch Drive Plates

- Check facing for burns, cracks or damage.

REPAIR FOR COMPONENT PARTS

High and Low Reverse Clutch Retaining Plate and Driven Plates

- Check facing for burns, cracks or damage.

ASSEMBLY

1. Install drive plates, driven plates and retaining plate in high and low reverse clutch drum.

CAUTION:

Take care with the order of plates.

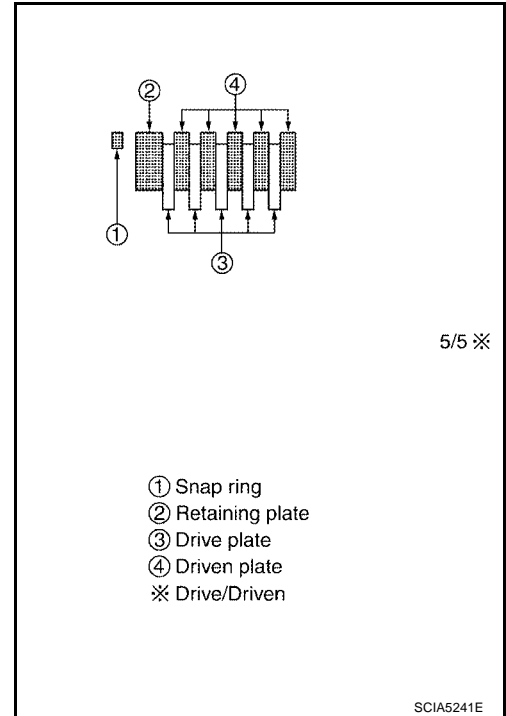

2. Using a flat-bladed screwdriver, install snap ring in high and low reverse clutch drum.

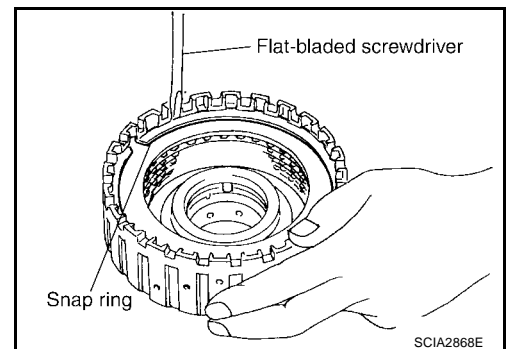

3. Install bearing race to high and low reverse clutch drum.

CAUTION:

Apply petroleum jelly to bearing race.

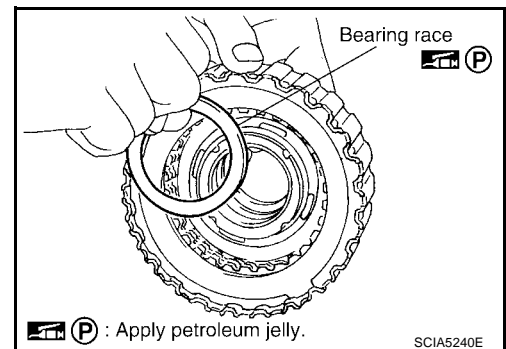

REPAIR FOR COMPONENT PARTS

Direct Clutch COMPONENTS

ECS00CD2

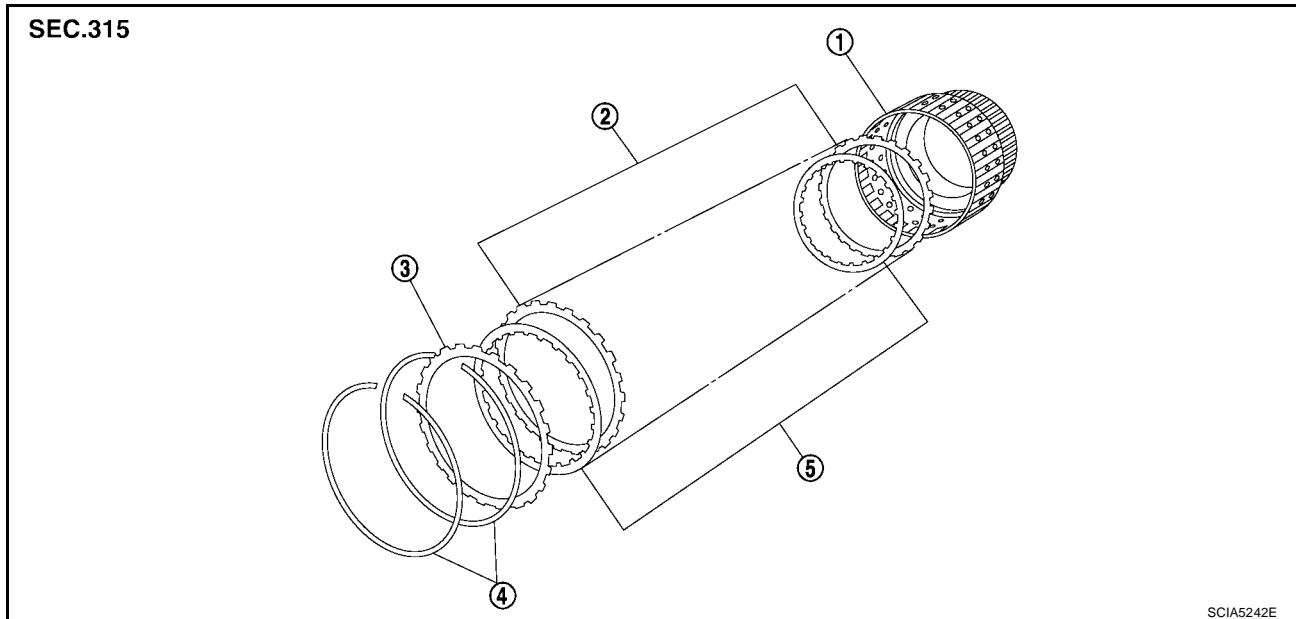

- | | | |
|-----------------------|-----------------|--------------------|
| 1. Direct clutch drum | 2. Driven plate | 3. Retaining plate |
| 4. Snap ring | 5. Drive plate | |

DISASSEMBLY

1. Using a flat-bladed screwdriver, remove snap rings from direct clutch drum.
2. Remove drive plates, driven plates and retaining plate from direct clutch drum.

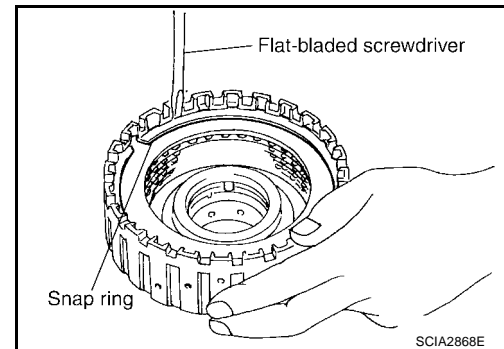

INSPECTION

- Check the following, and replace direct clutch assembly if necessary.

Direct Clutch Snap Rings

- Check for deformation, fatigue or damage.

Direct Clutch Drive Plates

- Check facing for burns, cracks or damage.

Direct Clutch Retaining Plate and Driven Plates

- Check facing for burns, cracks or damage.

A
B
AT
D
E
F
G
H
I
J
K
L
M

REPAIR FOR COMPONENT PARTS

ASSEMBLY

1. Install drive plates, driven plates and retaining plate in direct clutch drum.

CAUTION:

Take care with the order of plates.

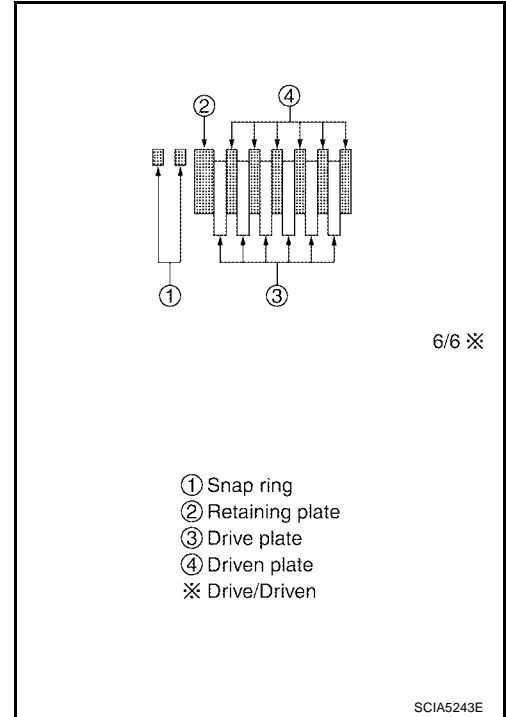

2. Using a flat-bladed screwdriver, install snap rings in direct clutch drum.

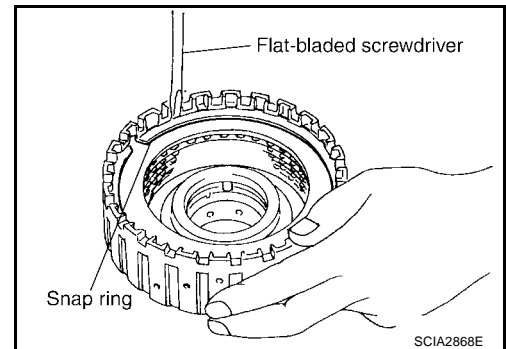

ASSEMBLY

ASSEMBLY

PFP:00000

EC500CD3

Assembly (1)

1. As shown in the right figure illustration, use a drift [commercial service tool $\phi 22$ mm (0.87 in)] to drive manual shaft oil seals into the transmission case until it is flush.

CAUTION:

- Apply ATF to manual shaft oil seals.
- Do not reuse manual shaft oil seals.

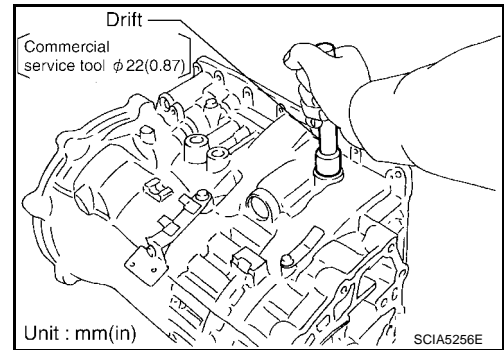

2. Install detent spring and spacer in transmission case. Tighten bolt to the specified torque. Refer to [AT-271, "Components"](#).

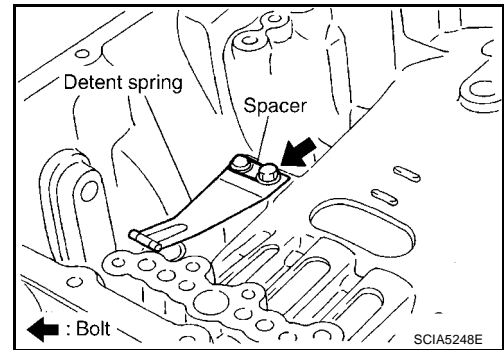

3. Install manual shaft to transmission case.
4. Install parking rod to manual plate.

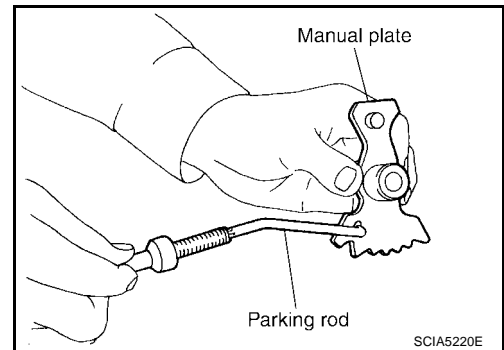

5. Install manual plate (with parking rod) to manual shaft.

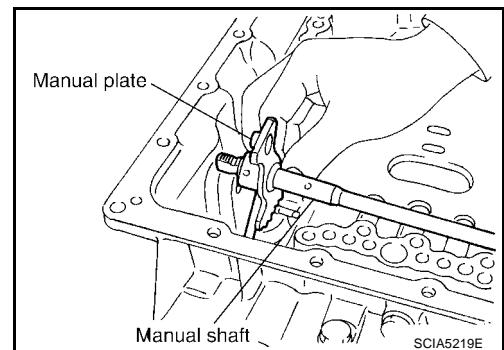

A
B
AT
D
E
F
G
H
I
J
K
L
M

ASSEMBLY

6. Install retaining pin into the manual plate and manual shaft.
 - a. Fit pinhole of the manual plate to pinhole of the manual shaft with a pin punch.
 - b. Use a hammer to tap the retaining pin into the manual plate.

CAUTION:

- Drive retaining pin to ± 0.5 mm over the manual plate.
- Do not reuse retaining pin.

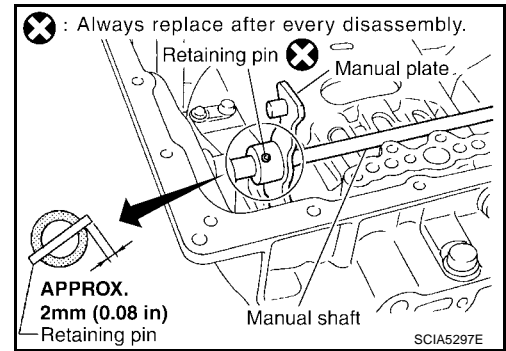

7. Install retaining pin into the transmission case and manual shaft.
 - a. Fit pinhole of the transmission case to pinhole of the manual shaft with a pin punch.
 - b. Use a hammer to tap the retaining pin into the transmission case.

CAUTION:

- Drive retaining pin to ± 1 mm over the transmission case.
- Do not reuse retaining pin.

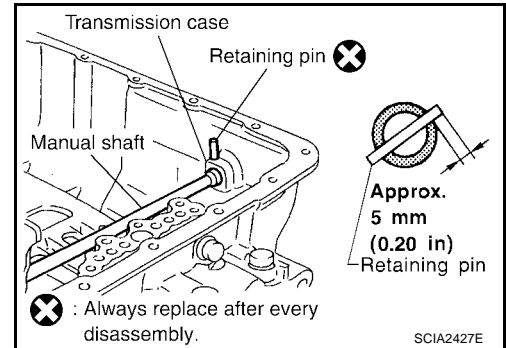

8. Install O-rings to servo assembly.

CAUTION:

- Do not reuse O-rings.
- Apply petroleum jelly to O-rings.

9. Install return spring to servo assembly.
10. Install servo assembly in transmission case.

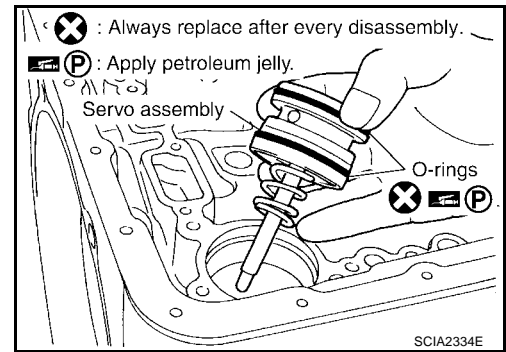

11. Using snap ring pliers, install snap ring to transmission case.

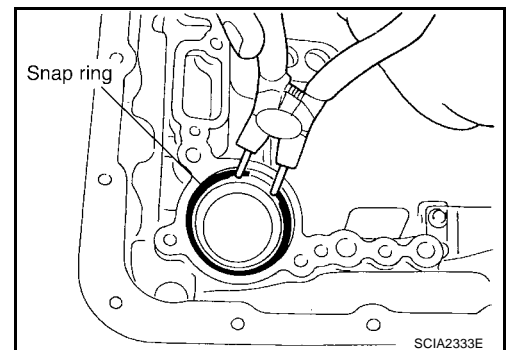

12. Install D-rings in reverse brake piston.

CAUTION:

- Do not reuse D-rings.
- Apply ATF to D-rings.

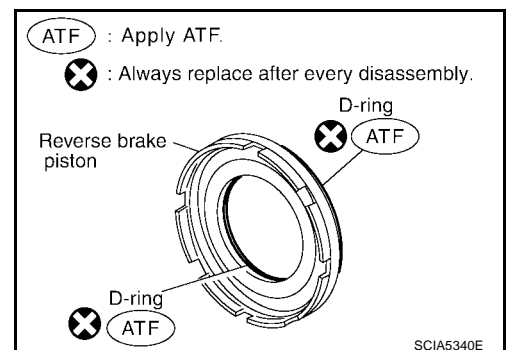

ASSEMBLY

13. Install reverse brake piston in transmission case.

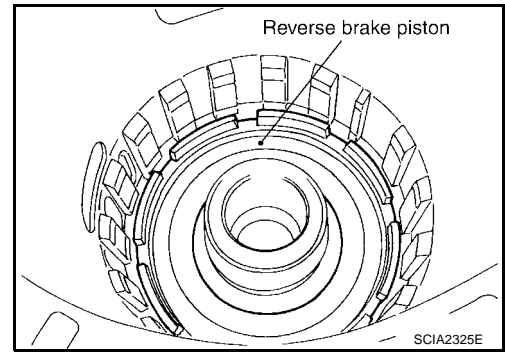

14. Install needle bearing to drum support edge surface.

CAUTION:

Apply petroleum jelly to needle bearing.

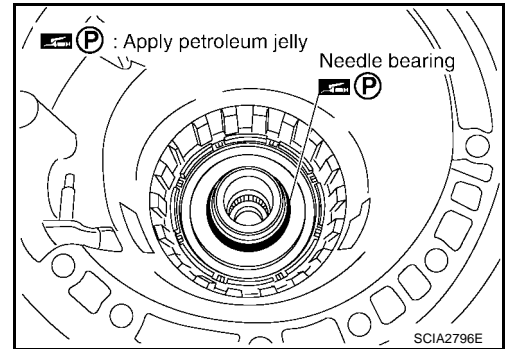

15. Install seal rings to drum support.

CAUTION:

- Do not reuse seal rings.
- Apply petroleum jelly to seal rings.

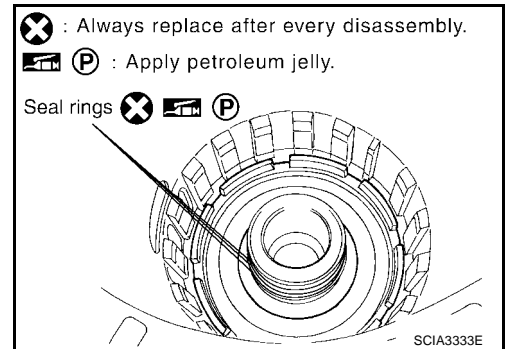

16. Install spring retainer and return spring in transmission case.

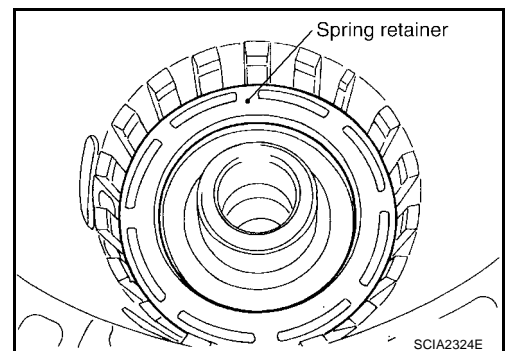

A
B
AT
D
E
F
G
H
I
J
K
L
M

ASSEMBLY

17. Set SST on spring retainer and install snap ring (fixing spring retainer) in transmission case while compressing return spring.

CAUTION:

Securely assemble them using a flat-bladed screwdriver so that snap ring tension is slightly weak.

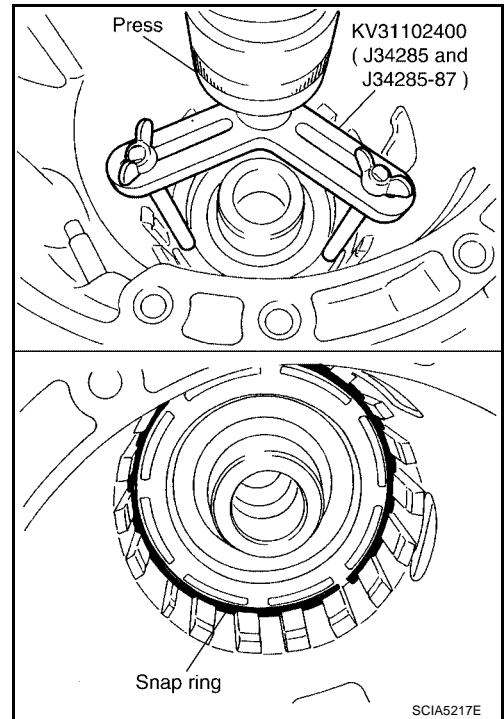

18. Install reverse brake drive plates, driven plates and dish plate in transmission case.

CAUTION:

Take care with the order and direction of plates.

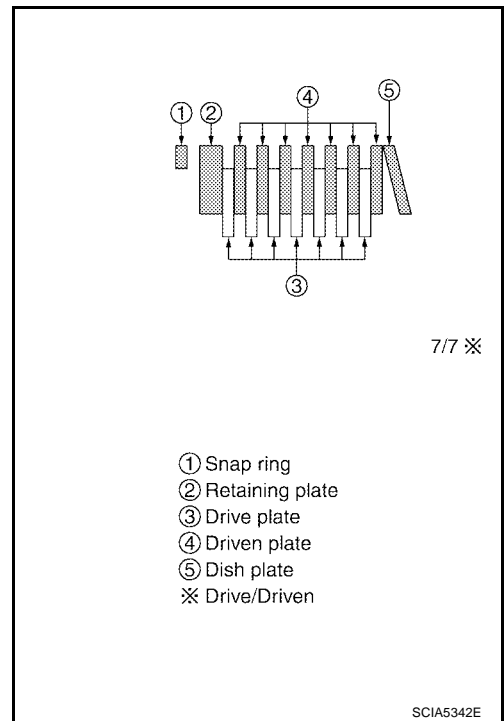

ASSEMBLY

19. Assemble N-spring.
20. Install reverse brake retaining plate in transmission case.

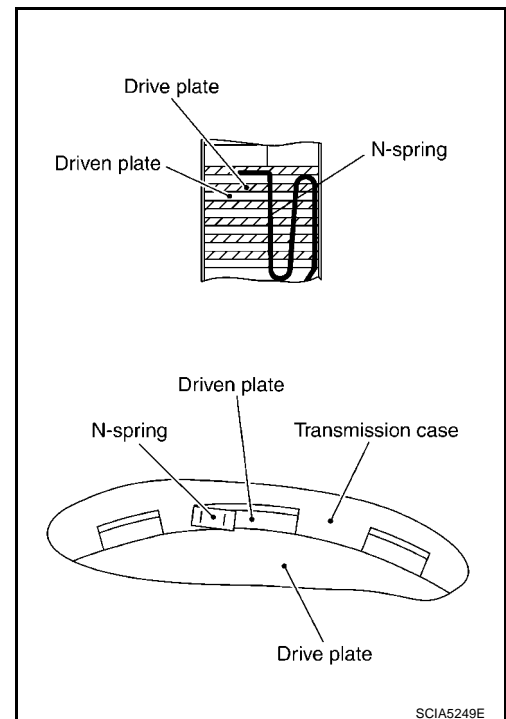

21. Install snap ring in transmission case.

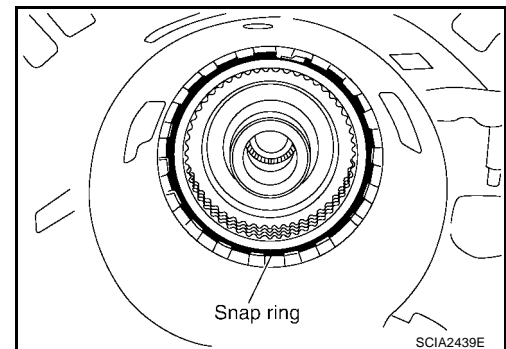

22. Measure clearance between retaining plate and snap ring. If not within specified clearance, select proper retaining plate.

Specified clearance "A":

Standard: 0.7 - 1.1mm (0.028 - 0.043 in)

Retaining plate:

Refer to [AT-343, "Reverse brake"](#).

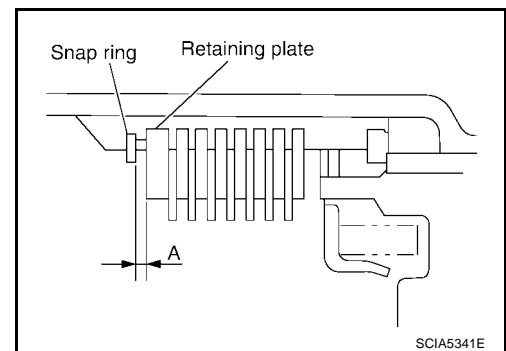

23. Install needle bearing to transmission case.

CAUTION:

- Take care with the direction of needle bearing. Refer to [AT-281, "Locations of Adjusting Shims, Needle Bearings, Thrust Washers and Snap Rings"](#).
- Apply petroleum jelly to needle bearing.

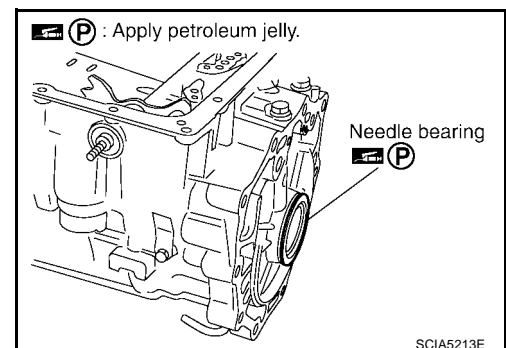

A
B
AT
D
E
F
G
H
I
J
K
L
M

ASSEMBLY

24. Install revolution sensor to transmission case. Tighten revolution sensor bolt to the specified torque. Refer to [AT-271, "Components"](#).

CAUTION:

- Do not subject it to impact by dropping or hitting it.
- Be careful not to damage harness with the edge of case.
- Do not allow metal filings, etc., to get on the sensor's front edge magnetic area.
- Do not place in an area affected by magnetism.

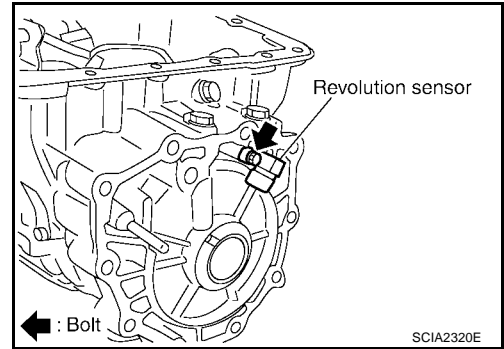

25. As shown in the right figure illustration, use a drift to drive rear oil seal into the rear extension (2WD models) or adapter case (4WD models) until it is flush.

CAUTION:

- Apply ATF to rear oil seal.
- Do not reuse rear oil seal.

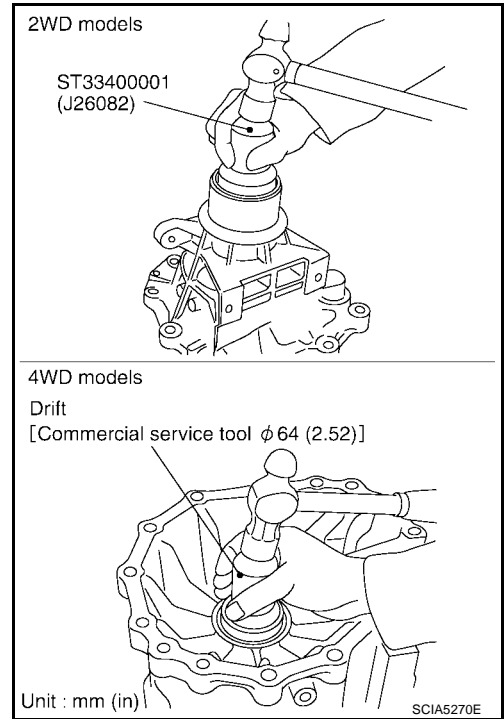

26. Install return spring to parking pawl.

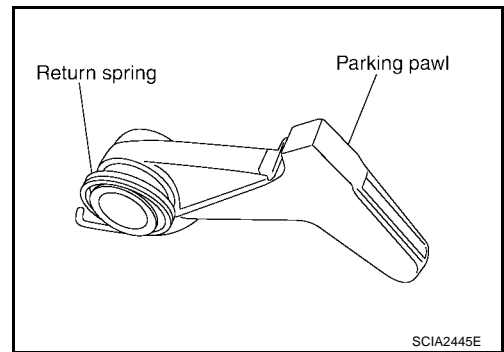

27. Install parking pawl (with return spring) and pawl shaft to rear extension (2WD models) or adapter case (4WD models).

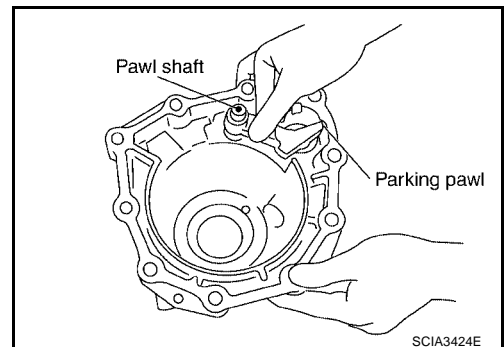

ASSEMBLY

28. Install parking actuator support to rear extension (2WD models) or adapter case (4WD models).

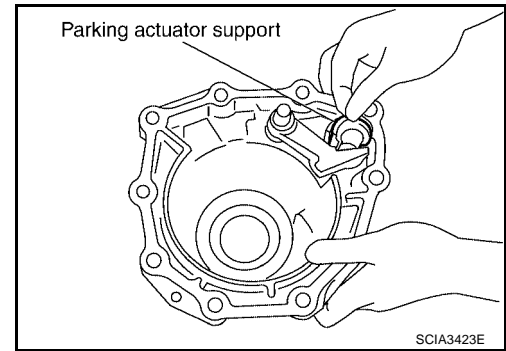

29. Install needle bearing to rear extension (2WD models) or adapter case (4WD models).

CAUTION:

Apply petroleum jelly to needle bearing.

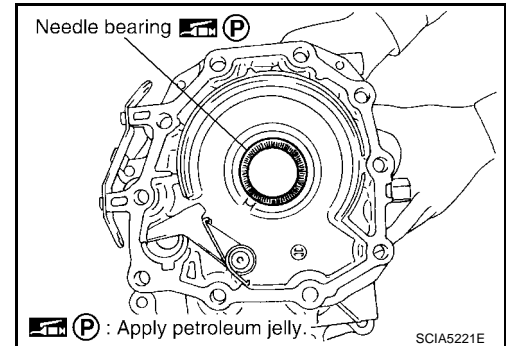

30. Install seal rings to output shaft.

CAUTION:

- Do not reuse seal rings.
- Apply petroleum jelly to seal rings.

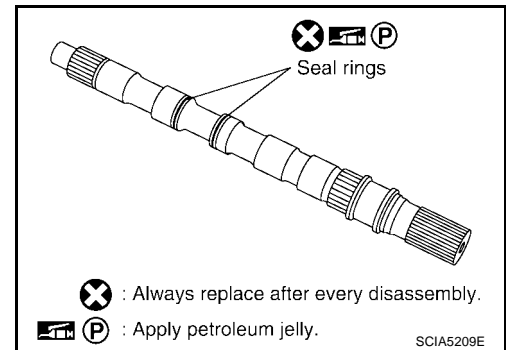

31. Install parking gear to output shaft.

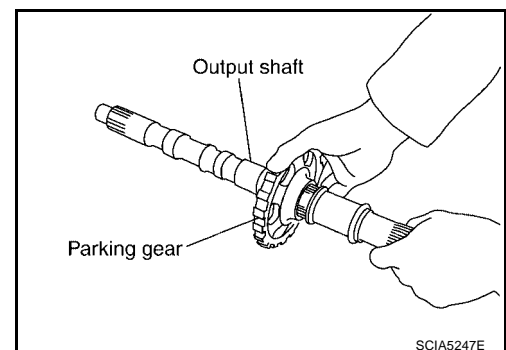

32. Install output shaft in transmission case.

CAUTION:

Be careful not to mistake front for rear because both sides looks similar. (Thinner end is front side.)

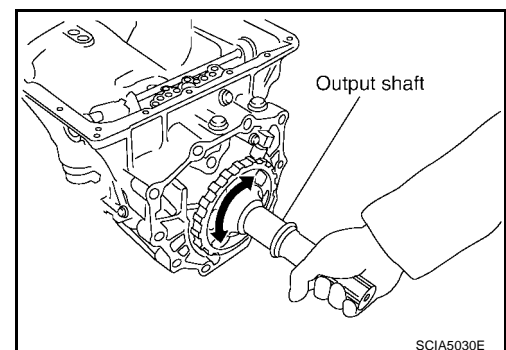

ASSEMBLY

33. Install bearing race in output shaft.

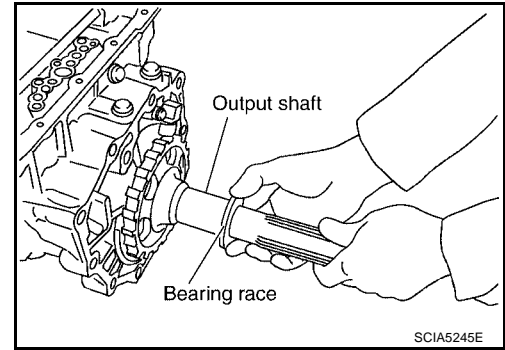

34. Install rear extension assembly (2WD models) or adapter case assembly (4WD models) according to the following procedures.

a. **2WD models**

i. Apply recommended sealant (Genuine Anaerobic Liquid Gasket or equivalent. Refer to [GI-45, "Recommended Chemical Products and Sealants"](#) .) to rear extension assembly as shown in illustration.

CAUTION:

Complete remove all moisture, oil and old sealant, etc. From the transmission case and rear extension assembly mounting surfaces.

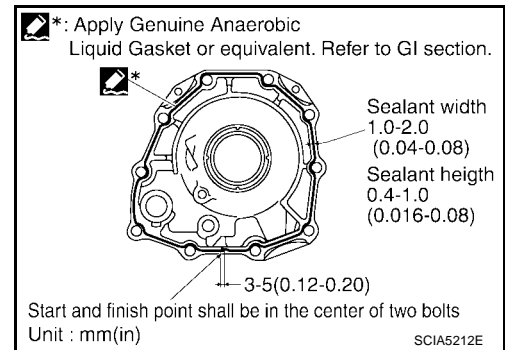

ii. Install rear extension assembly to transmission case.

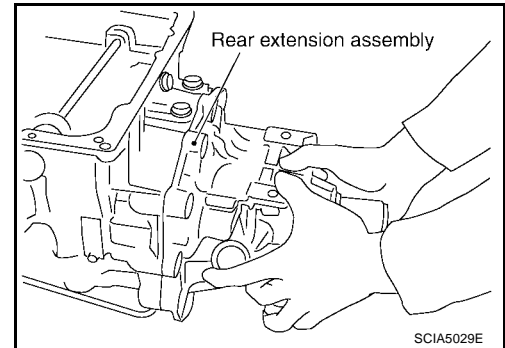

iii. Install bracket.

iv. Tighten rear extension assembly bolts to specified torque.

CAUTION:

Do not reuse self-sealing bolt.

Rear extension assembly bolt:
: 52 N·m (5.3 kg·m, 38 ft·lb)

Self-sealing bolt:
: 61 N·m (6.2 kg·m, 45 ft·lb)

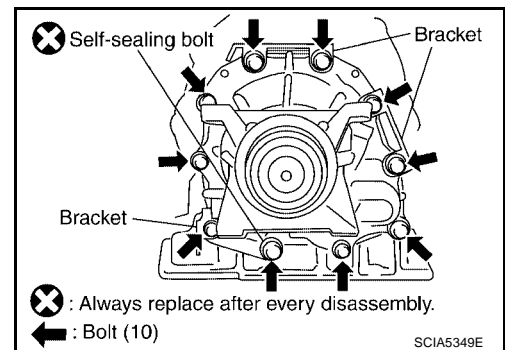

ASSEMBLY

b. **4WD models**

i. Install gasket to transmission case.

CAUTION:

- Do not reuse gasket.
- Complete remove all moisture, oil and old gasket, etc. From the transmission case and adapter case assembly mounting surfaces.

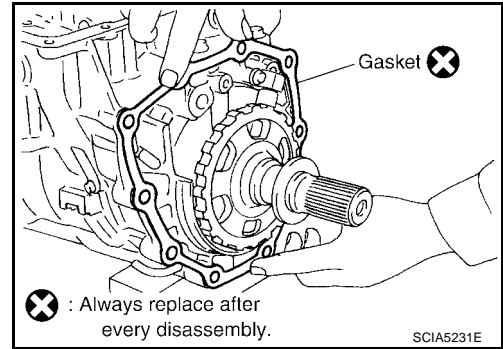

ii. Install adapter case assembly to transmission case.

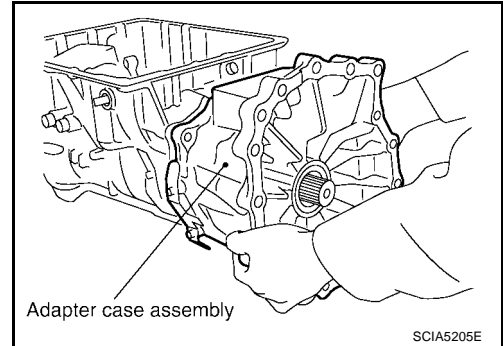

iii. Install bracket.

iv. Tighten adapter case assembly bolts to specified torque.

CAUTION:

Do not reuse self-sealing bolt.

Adapter case assembly bolt:

 : 52 N·m (5.3 kg-m, 38 ft-lb)

Self-sealing bolt:

 : 61 N·m (6.2 kg-m, 45 ft-lb)

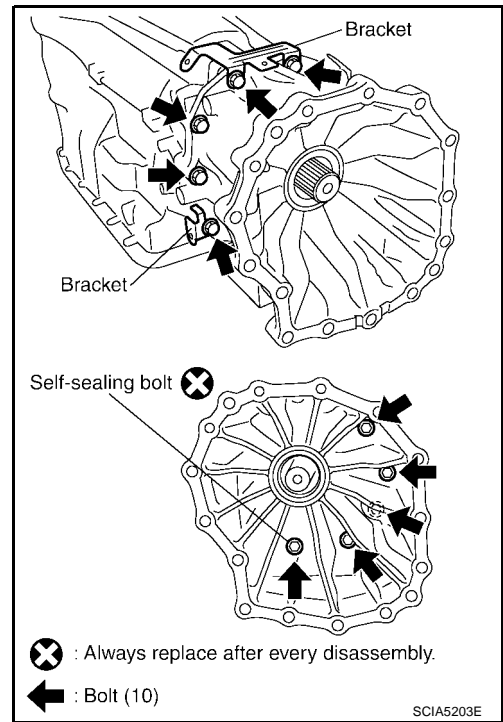

35. Install needle bearing in drum support edge surface.

CAUTION:

Apply petroleum jelly to needle bearing.

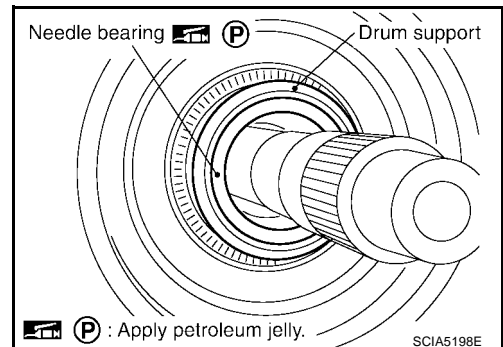

A
B
AT

D
E
F
G

H
I
J
K

L
M

ASSEMBLY

36. Install direct clutch assembly in reverse brake.

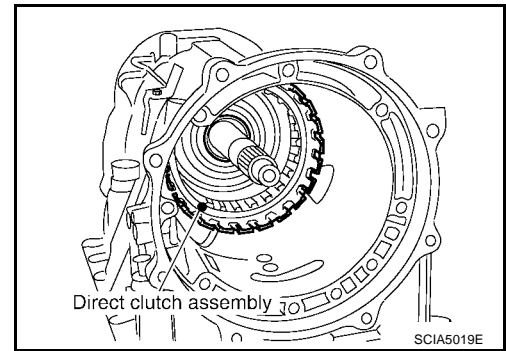

37. Install high and low reverse clutch assembly in direct clutch assembly.

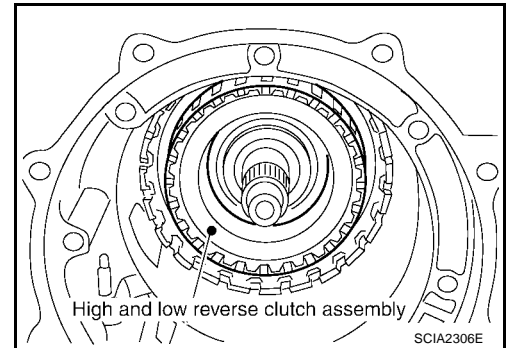

38. Using a flat-bladed screwdriver, range the drive plate.

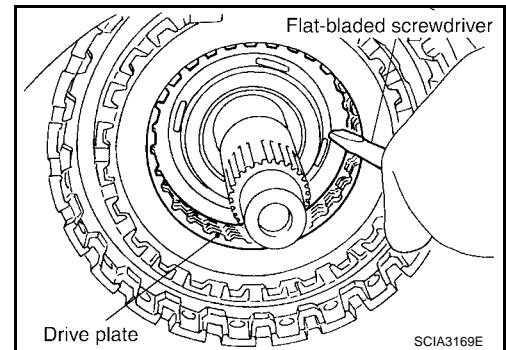

39. Install high and low reverse clutch hub, mid sun gear assembly and rear sun gear assembly as a unit.

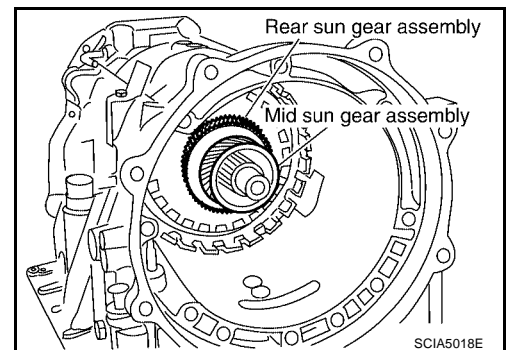

ASSEMBLY

CAUTION:

Check that portion A of high and low reverse clutch drum protrudes approximately 2 mm (0.08 in) beyond portion B of rear sun gear.

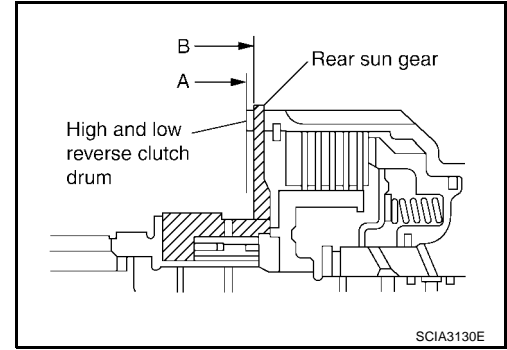

40. Install needle bearing in rear carrier assembly.

CAUTION:

Apply petroleum jelly to needle bearing.

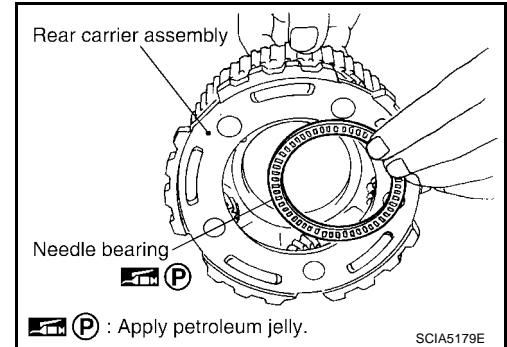

41. Install bearing race in rear carrier assembly.

CAUTION:

Apply petroleum jelly to bearing race.

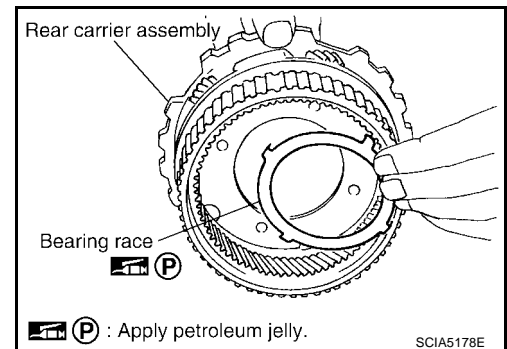

42. Install rear carrier assembly in direct clutch drum.

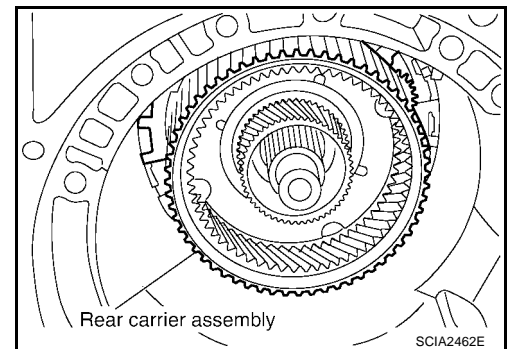

A
B
AT
D
E
F
G
H
I
J
K
L
M

ASSEMBLY

43. Install needle bearing (rear side) in mid carrier assembly.

CAUTION:

Apply petroleum jelly to needle bearing.

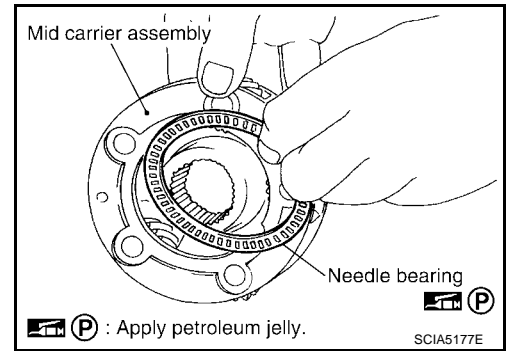

44. Install needle bearing (front side) in mid carrier assembly.

CAUTION:

Apply petroleum jelly to needle bearing.

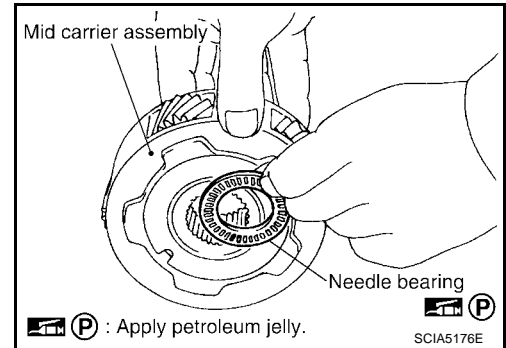

45. Install mid carrier assembly in rear carrier assembly.

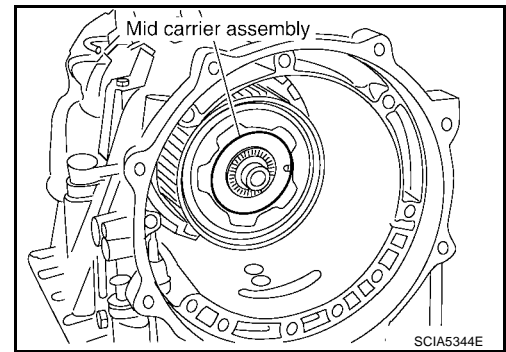

46. Install front carrier assembly, input clutch assembly and rear internal gear as a unit.

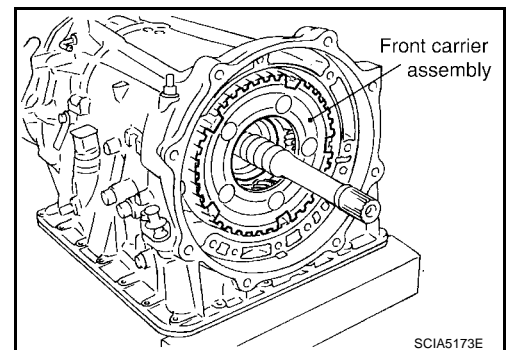

47. Install seal rings in input clutch assembly.

CAUTION:

- Do not reuse seal rings.
- Apply petroleum jelly to seal rings.

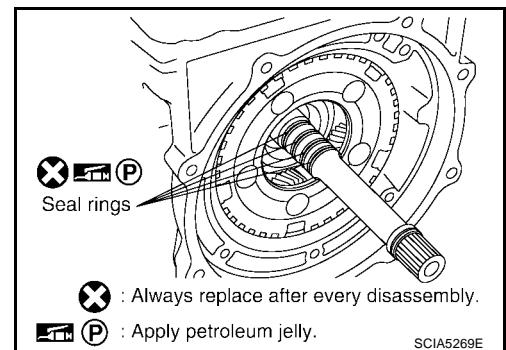

ASSEMBLY

48. Install band servo anchor end pin and lock nut in transmission case.

CAUTION:

Do not reuse band servo anchor end pin.

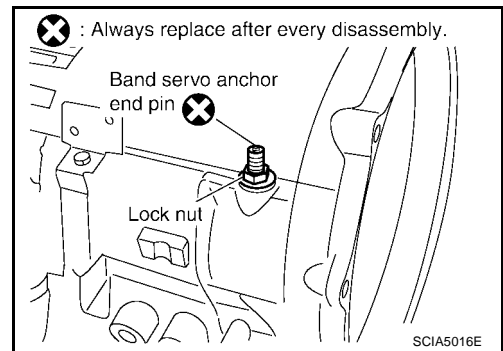

49. Install brake band in transmission case.

CAUTION:

Assemble it so that identification to avoid incorrect installation faces servo side.

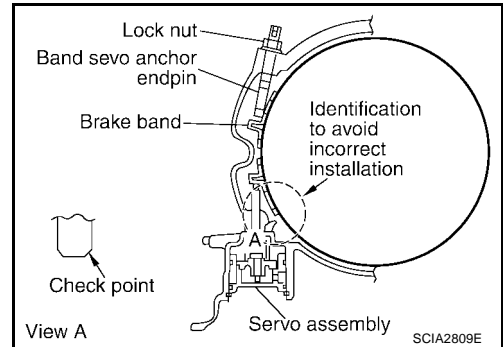

50. Install front sun gear assembly to front carrier assembly.

CAUTION:

Apply ATF to front sun gear radial bearing and 3rd one-way clutch end bearing.

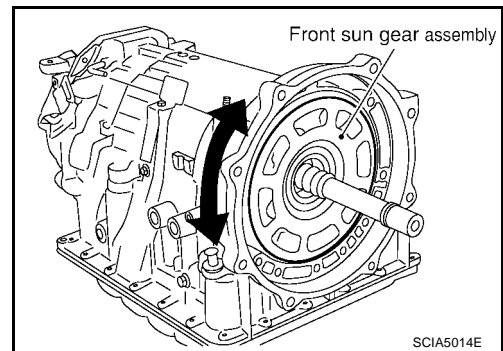

51. Install needle bearing in front sun gear assembly.

CAUTION:

Apply petroleum jelly to needle bearing.

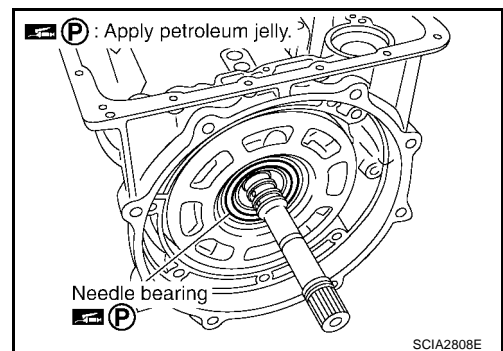

52. Adjust brake band tilting using clips so that brake band contacts front sun gear drum evenly.

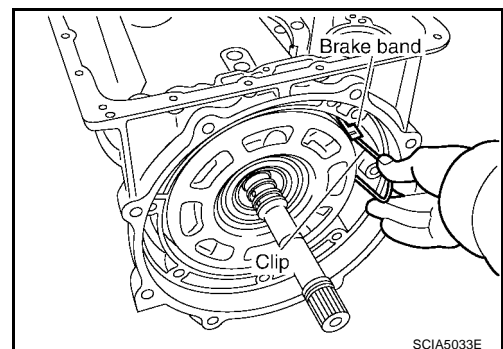

A
B
AT
D
E
F
G
H
I
J
K
L
M

ASSEMBLY

53. Adjust brake band.

- a. Loosen lock nut.
- b. Tighten band servo anchor end pin to specified torque.

 : 5.0 N·m (0.51 kg·m, 44 in·lb)

- c. Back of band servo anchor end pin three turns.
- d. Holding band servo anchor end pin, tighten lock nut to specified torque. Refer to [AT-271, "Components"](#).

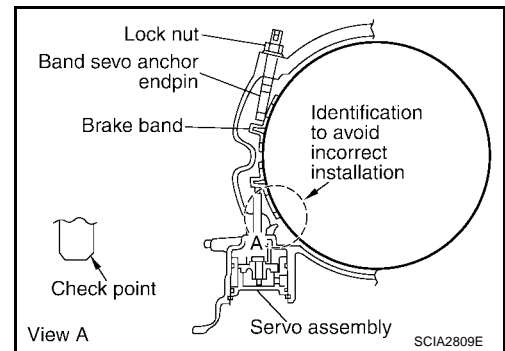

ECS00CD4

Adjustment TOTAL END PLAY

- Measure clearance between front sun gear and bearing race for oil pump cover.
- Select proper thickness of bearing race so that end play is within specifications.

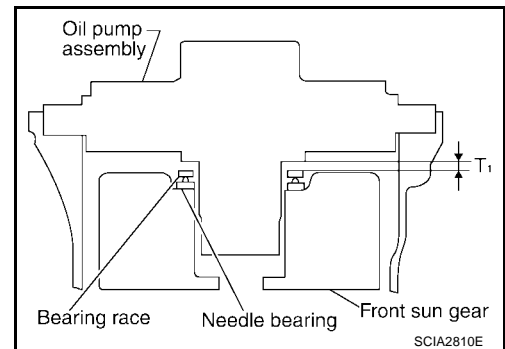

1. Measure dimensions "K" and "L" and then calculate dimension "J".

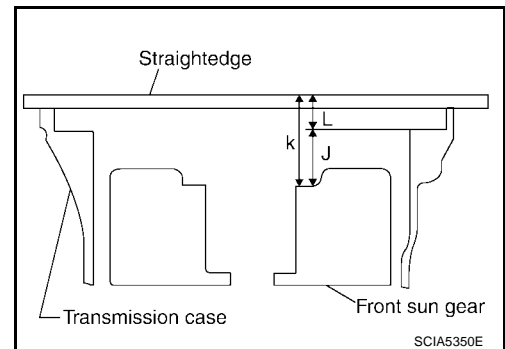

- a. Measure dimension "K".

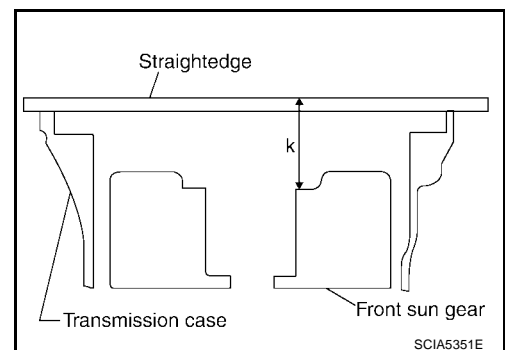

ASSEMBLY

- b. Measure dimension "L".
- c. Calculate dimension "J".

"J": Distance between oil pump fitting surface of transmission case and needle bearing mating surface of front sun gear.

$$J = K - L$$

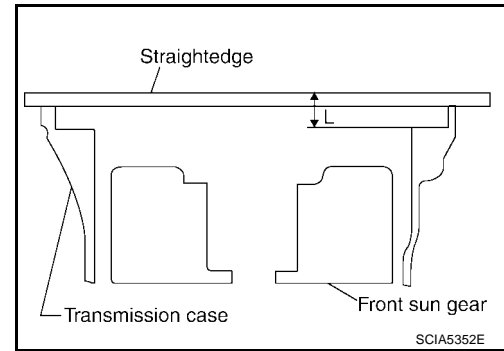

2. Measure dimensions "M1" and "M2" and then calculate dimension "M".

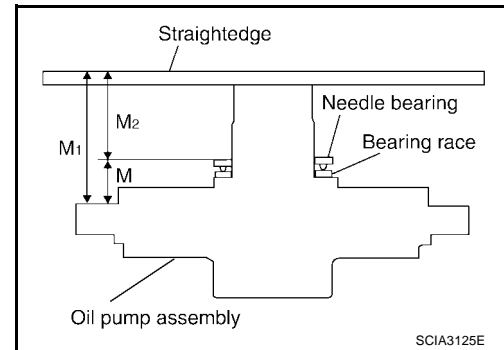

- a. Place bearing race and needle bearing on oil pump assembly.

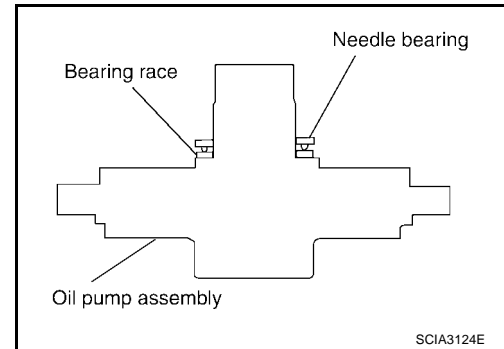

- b. Measure dimension "M1".

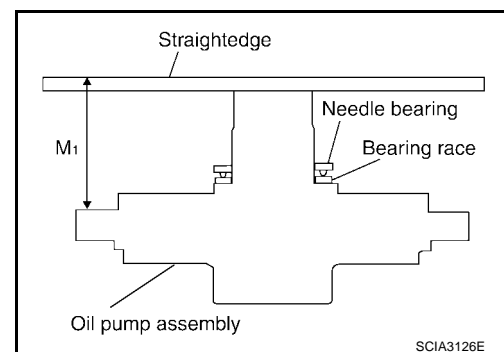

- c. Measure dimension "M2".

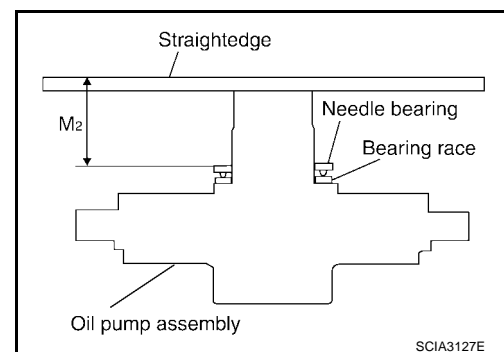

A
B
AT

D
E
F
G

H
I
J
K

L
M

ASSEMBLY

d. Calculate dimension "M".

"M": Distance between transmission case fitting surface of oil pump and needle bearing on oil pump.

$$M = M_1 - M_2$$

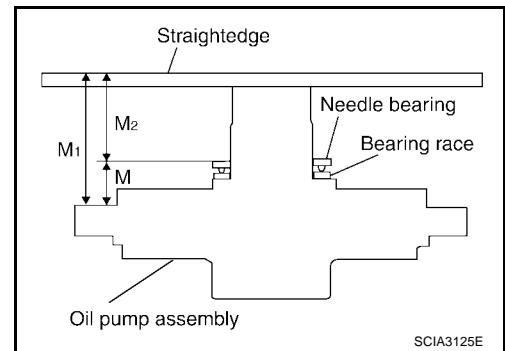

3. Adjust total end play "T₁".

$$T_1 = J - M$$

Total end play "T₁":

0.25 - 0.55 mm (0.0098 - 0.0217 in)

- Select proper thickness of bearing race so that total end play is within specifications.

Bearing races:

Refer to AT-343, "BEARING RACE FOR ADJUSTING TOTAL END PLAY".

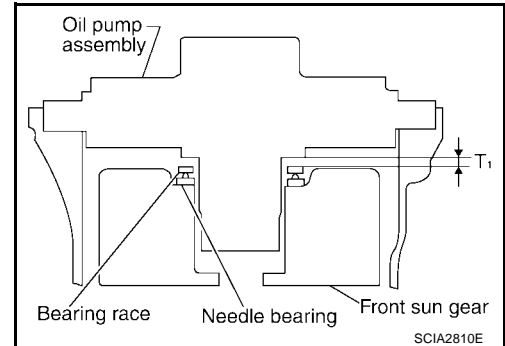

Assembly (2)

1. Install O-ring to oil pump assembly.

CAUTION:

- Do not reuse O-ring.
- Apply ATF to O-ring.

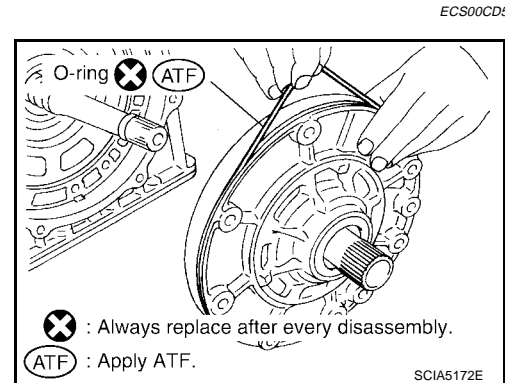

2. Install bearing race to oil pump assembly.

CAUTION:

Apply petroleum jelly to bearing race.

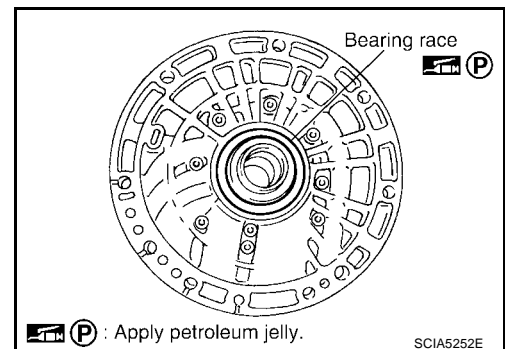

ASSEMBLY

3. Install oil pump assembly in transmission case.

CAUTION:

Apply ATF to oil pump radial bearing.

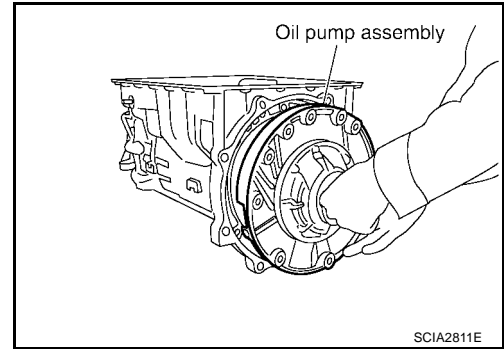

4. Apply recommended sealant (Genuine RTV Silicone Sealant or equivalent. Refer to [GI-45, "Recommended Chemical Products and Sealants"](#) .) to oil pump assembly as shown.

CAUTION:

Complete remove all moisture, oil and old sealant, etc. From the oil pump mounting bolts and oil pump mounting bolt mounting surfaces.

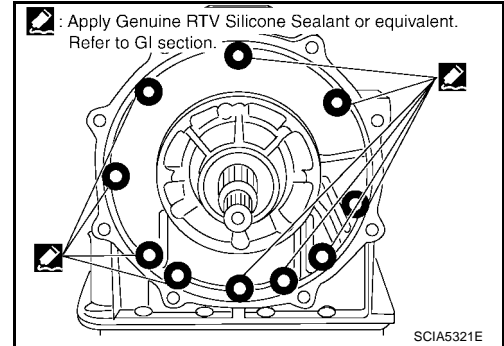

5. Tighten oil pump bolts to specified torque. Refer to [AT-271, "Components"](#) .

CAUTION:

Apply ATF to oil pump bushing.

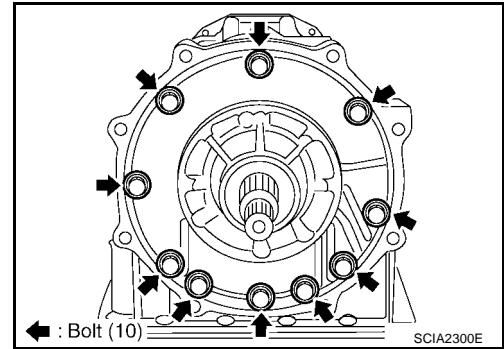

6. Install O-ring to input clutch assembly.

CAUTION:

- Do not reuse O-ring.
- Apply ATF to O-ring.

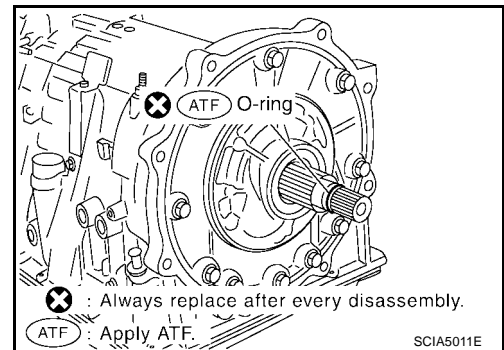

7. Install converter housing to transmission case.

CAUTION:

Do not reuse self-sealing bolt.

Converter housing bolt:

: 52 N·m (5.3 kg·m, 38 ft·lb)

Self-sealing bolt:

: 61 N·m (6.2 kg·m, 45 ft·lb)

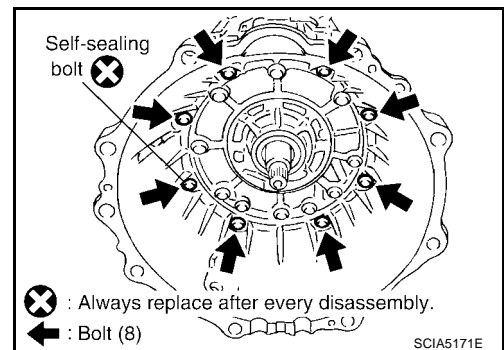

A
B
AT
D
E
F
G
H
I
J
K
L
M

ASSEMBLY

8. Make sure that brake band does not close turbine revolution sensor hole.

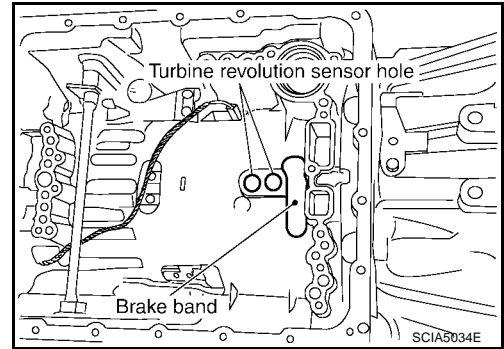

9. Install control valve with TCM.
a. Install A/T fluid temperature sensor 2 to bracket.

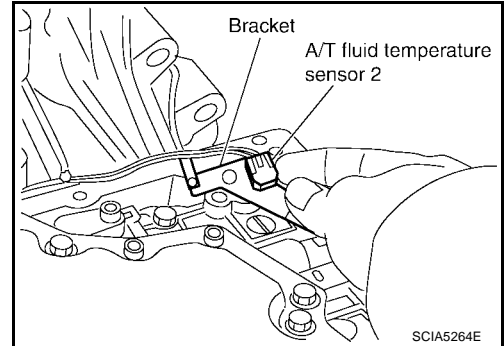

- b. Install A/T fluid temperature sensor 2 (with bracket) in control valve with TCM. Tighten A/T fluid temperature sensor 2 mounting bolt to the specified torque. Refer to [AT-271, "Components"](#).

CAUTION:

Adjust bolt hole of bracket to bolt hole of control valve with TCM.

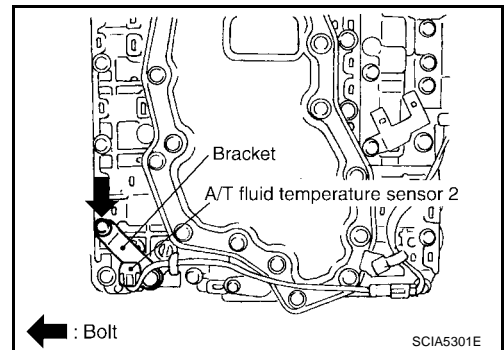

- c. Install O-ring to A/T assembly harness connector.

CAUTION:

- Do not reuse O-ring.
- Apply ATF to O-ring.

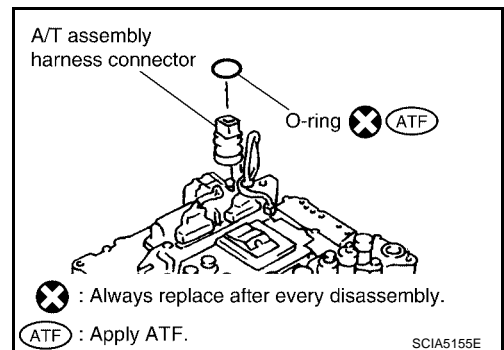

- d. Install control valve with TCM in transmission case.

CAUTION:

- Make sure that turbine revolution sensor securely installs turbine revolution sensor hole.
- Adjust A/T assembly harness connector of control valve with TCM to terminal hole of transmission case.
- Hang down revolution sensor harness toward outside so as not to disturb installation of control valve with TCM.

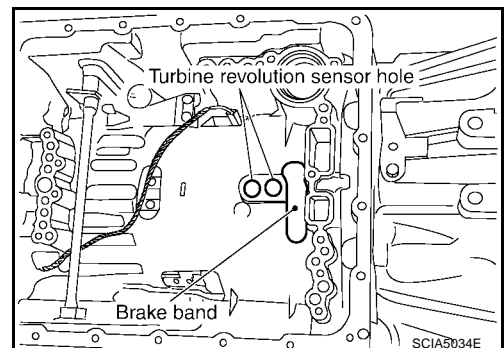

ASSEMBLY

- Assemble it so that manual valve cutout is engaged with manual plate projection.

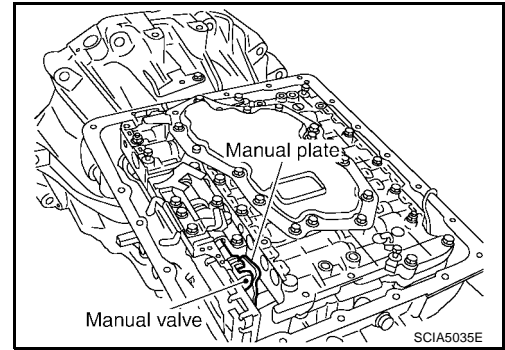

A
B
AT

e. Install bolts A, B and C to control valve with TCM.

Bolt symbol	Length: mm (in)	Number of bolts
A	42 (1.65)	5
B	55 (2.17)	6
C	40 (1.57)	1

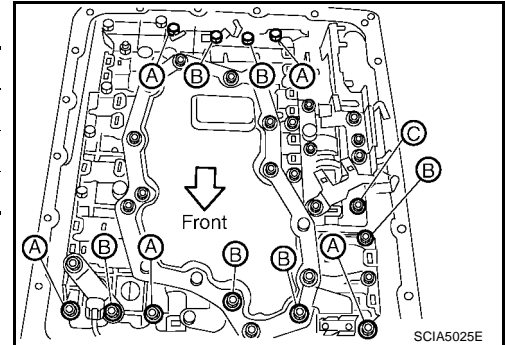

D
E
F

f. Tighten bolt 1, 2 and 3 temporarily to prevent dislocation. After that tighten them in order (1 → 2 → 3), and then tighten other bolts.

g. Tighten control valve with TCM bolts to the specified torque. Refer to [AT-271, "Components"](#).

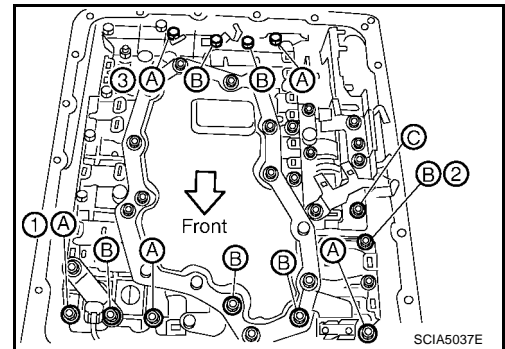

G
H
I

10. Connect A/T fluid temperature sensor 2 connector.

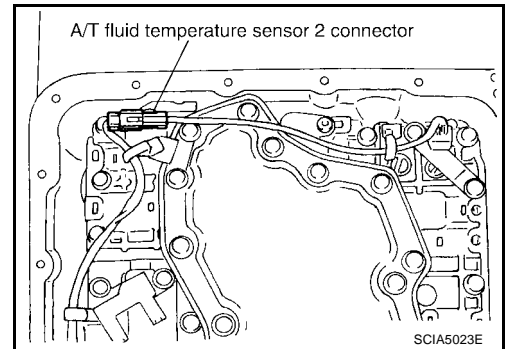

J
K
L

11. Securely fasten A/T fluid temperature sensor 2 harness with terminal clip.

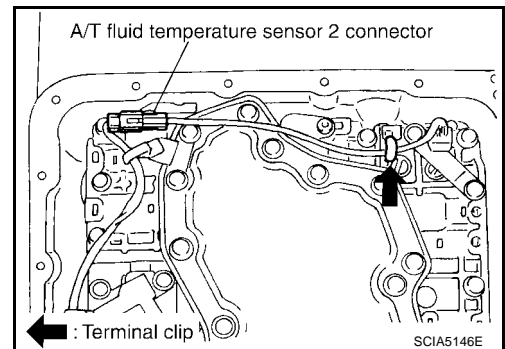

M

ASSEMBLY

12. Connect revolution sensor connector.

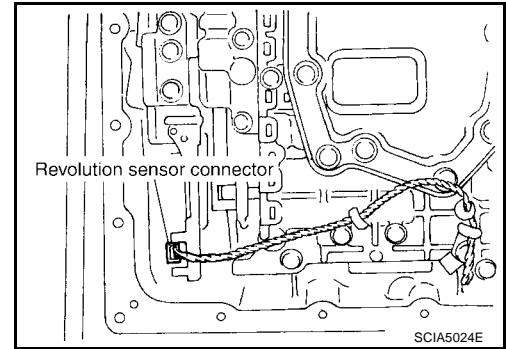

13. Securely fasten revolution sensor harness with terminal clips.

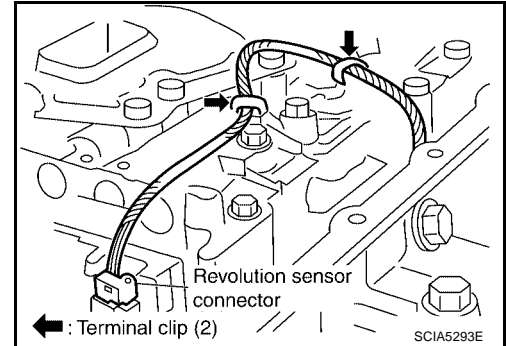

14. Pull down A/T assembly harness connector.

CAUTION:
Be careful not to damage connector.

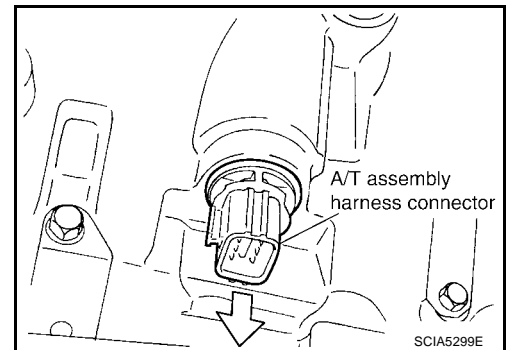

15. Install snap ring to A/T assembly harness connector.

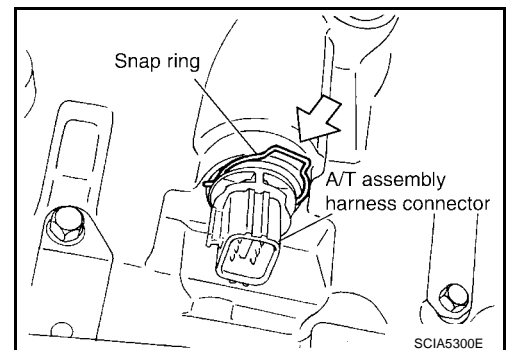

16. Install magnets in oil pan.

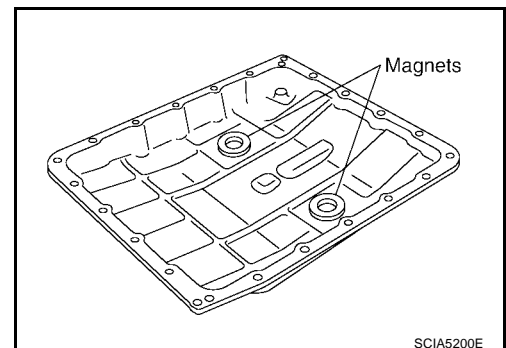

ASSEMBLY

17. Install oil pan to transmission case.

a. Install oil pan gasket to oil pan.

CAUTION:

- Do not reuse oil pan gasket.
- Install it in the direction to align hole positions.
- Complete remove all moisture, oil and old gasket, etc. From the oil pan gasket mounting surfaces.

b. Install oil pan (with oil pan gasket) to transmission case.

CAUTION:

- Install it so that drain plug comes to the position as shown in the figure.
- Be careful not to pinch harnesses.
- Complete remove all moisture, oil and old gasket, etc. From the oil pan mounting surfaces.

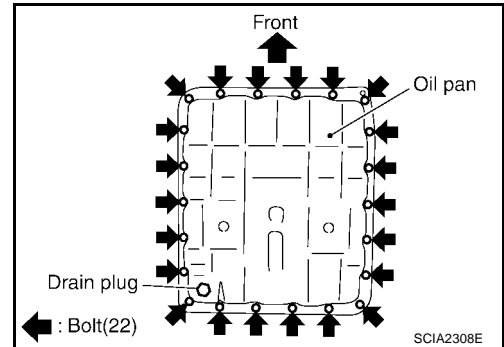

c. Tighten oil pan bolts to the specified torque in numerical order shown after temporarily tightening them. Refer to [AT-271, "Components"](#).

CAUTION:

Do not reuse oil pan bolts.

18. Install drain plug to oil pan. Tighten drain plug to the specified torque. Refer to [AT-271, "Components"](#).

CAUTION:

Do not reuse drain plug gasket.

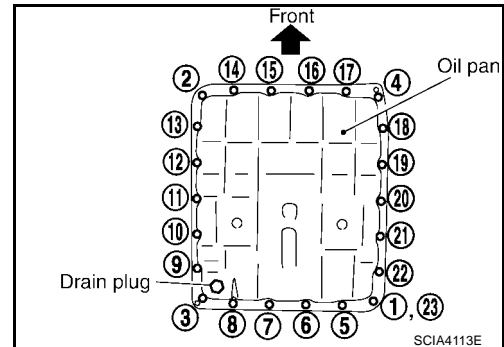

19. Install torque converter.

a. Pour ATF into torque converter.

- Approximately 2 liter (2-1/8 US qt, 1-3/4 Imp qt) of fluid is required for a new torque converter.
- When reusing old torque converter, add the same amount of fluid as was drained.

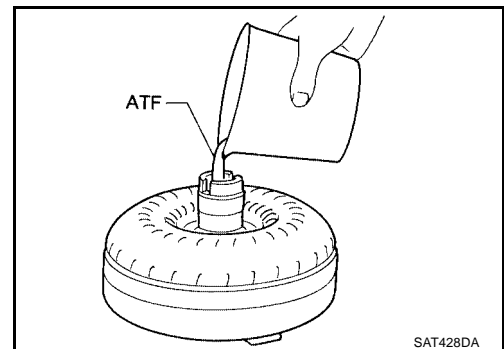

b. Install torque converter while aligning notches of torque converter with notches of oil pump.

CAUTION:

Install torque converter while rotating it.

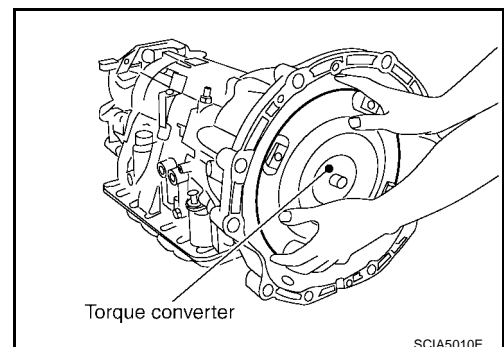

A
B
AT
D
E
F
G
H
I
J
K
L
M

ASSEMBLY

- c. Measure distance "A" to check that torque converter is in proper position.

Distance "A":

: 24.0 mm (0.94 in) or more

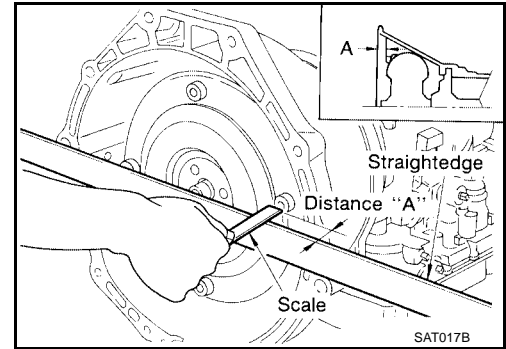

SERVICE DATA AND SPECIFICATIONS (SDS)

SERVICE DATA AND SPECIFICATIONS (SDS)

PF0:00030

General Specifications

ECS00CD6

Applied model	4x2		4x4	
Automatic transmission model	RE5R05A			
Transmission model code number	95X17		95X18	
Stall torque ratio	2.0: 1			
Transmission gear ratio	1st	3.827		
	2nd	2.368		
	3rd	1.520		
	4th	1.000		
	5th	0.834		
	Reverse	2.613		
Recommended fluid	NISSAN Matic Fluid J*1			
Fluid capacity	10.6 liter (11-1/4 US qt, 9-3/8 Imp qt)			

CAUTION:

- Use only Genuine NISSAN ATF Matic Fluid J. Do not mix with other fluid.
- Using automatic transmission fluid other than Genuine NISSAN an ATF Matic Fluid J will deteriorate in driveability and automatic transmission durability, and may damage the automatic transmission, which is not covered by the warranty.

*1: Refer to [MA-11, "Fluids and Lubricants"](#).

Vehicle Speed When Shifting Gears NORMAL MODE

ECS00CD7

Final gear ratio	Throttle position	Vehicle speed km/h (MPH)							
		D1 →D2	D2 →D3	D3 →D4	D4 →D5	D5 →D4	D4 →D3	D3 →D2	D2 →D1
2.937	Full throttle	70 - 74 (44 - 46)	112 - 120 (70 - 75)	176 - 186 (110 - 116)	249 - 259 (155 - 161)	245 - 255 (152 - 159)	166 - 176 (103 - 110)	100 - 108 (62 - 67)	43 - 47 (27 - 30)
	Half throttle	46 - 50 (28 - 31)	74 - 82 (46 - 51)	103 - 113 (64 - 70)	135 - 145 (84 - 90)	109 - 119 (68 - 74)	69 - 79 (43 - 49)	44 - 52 (27 - 32)	11 - 15 (7 - 10)
3.357	Full throttle	61 - 65 (38 - 41)	97 - 105 (61 - 66)	153 - 163 (95 - 102)	236 - 246 (147 - 153)	232 - 242 (144 - 151)	143 - 153 (89 - 95)	87 - 95 (54 - 59)	43 - 47 (27 - 29)
	Half throttle	41 - 45 (26 - 28)	66 - 74 (41 - 46)	89 - 99 (56 - 62)	117 - 127 (73 - 79)	95 - 105 (59 - 65)	59 - 69 (37 - 43)	38 - 46 (24 - 29)	11 - 15 (7 - 10)

- At half throttle, the accelerator opening is 4/8 of the full opening.

TOW MODE

Final gear ratio	Throttle position	Vehicle speed km/h (MPH)							
		D1 →D2	D2 →D3	D3 →D4	D4 →D5	D5 →D4	D4 →D3	D3 →D2	D2 →D1
2.937	Full throttle	70 - 74 (44 - 46)	112 - 120 (70 - 75)	176 - 186 (110 - 116)	249 - 259 (155 - 161)	245 - 255 (152 - 159)	166 - 176 (103 - 110)	100 - 108 (62 - 67)	43 - 47 (27 - 30)
	Half throttle	50 - 54 (31 - 34)	81 - 89 (50 - 55)	113 - 123 (70 - 76)	135 - 145 (84 - 90)	109 - 119 (68 - 74)	68 - 78 (42 - 48)	44 - 52 (27 - 32)	11 - 15 (7 - 10)
3.357	Full throttle	61 - 65 (38 - 41)	97 - 105 (61 - 66)	153 - 163 (95 - 102)	236 - 246 (147 - 153)	232 - 242 (144 - 151)	143 - 153 (89 - 95)	87 - 95 (54 - 59)	43 - 47 (27 - 29)
	Half throttle	43 - 47 (27 - 29)	72 - 80 (45 - 50)	98 - 108 (61 - 67)	117 - 127 (73 - 79)	95 - 105 (59 - 65)	59 - 69 (37 - 43)	37 - 45 (23 - 28)	11 - 15 (7 - 10)

- At half throttle, the accelerator opening is 4/8 of the full opening.

SERVICE DATA AND SPECIFICATIONS (SDS)

Vehicle Speed When Performing and Releasing Complete Lock-up

ECS00CD8

Final gear ratio	Throttle position	Vehicle speed km/h (MPH)	
		Lock-up "ON"	Lock-up "OFF"
2.937	Closed throttle	74 - 82 (46 - 51)	71 - 79 (45 - 49)
	Half throttle	188 - 196 (117 - 122)	136 - 144 (85 - 90)
3.357	Closed throttle	65 - 73 (41 - 46)	62 - 70 (39 - 44)
	Half throttle	168 - 176 (105 - 110)	118 - 126 (74 - 79)

- At closed throttle, the accelerator opening is less than 1/8 condition.
- At half throttle, the accelerator opening is 4/8 of the full opening.

Vehicle Speed When Performing and Releasing Slip Lock-up

ECS00CD9

Final gear ratio	Throttle position	Gear position	Vehicle speed km/h (MPH)	
			Slip lock-up "ON"	Slip lock-up "OFF"
2.937	Closed throttle	4th	52 - 60 (33 - 38)	49 - 57 (31 - 36)
		5th	52 - 60 (33 - 38)	49 - 57 (31 - 36)
3.357	Closed throttle	4th	46 - 54 (29 - 34)	43 - 51 (27 - 32)
		5th	46 - 54 (29 - 34)	43 - 51 (27 - 32)

- At closed throttle, the accelerator opening is less than 1/8 condition.

Stall Speed

ECS00CDA

Stall speed	2,500 - 2,800 rpm
-------------	-------------------

Line Pressure

ECS00CDB

Engine speed	Line pressure [kPa (kg/cm ² , psi)]	
	R position	D position
At idle speed	392 - 441 (4.0 - 4.5, 57 - 64)	373 - 422 (3.8 - 4.3, 54 - 61)
At stall speed	1,700 - 1,890 (17.3 - 19.3, 247 - 274)	1,310 - 1,500 (13.3 - 15.3, 190 - 218)

A/T Fluid Temperature Sensor

ECS00CDC

Name	Condition	CONSULT-II "DATA MONITOR" (Approx.) (V)	Resistance (Approx.) (kΩ)
A/T fluid temperature sensor 1	0°C (32°F)	2.2	15
	20°C (68°F)	1.8	6.5
	80°C (176°F)	0.6	0.9
A/T fluid temperature sensor 2	0°C (32°F)	2.2	10
	20°C (68°F)	1.7	4
	80°C (176°F)	0.45	0.5

Turbine Revolution Sensor

ECS00CDD

Name	Condition	Data (Approx.)
Turbine revolution sensor 1	When running at 50 km/h (31 MPH) in 4th speed with the closed throttle position switch "OFF".	1.3 (kHz)
Turbine revolution sensor 2	When moving at 20 km/h (12 MPH) in 1st speed with the closed throttle position switch "OFF".	

Vehicle Speed Sensor A/T (Revolution Sensor)

ECS00CDE

Name	Condition	Data (Approx.)
Revolution sensor	When moving at 20 km/h (12 MPH).	185 (Hz)

SERVICE DATA AND SPECIFICATIONS (SDS)

Reverse brake

ECS00CDF

	Thickness mm (in)	Part number*
Thickness of retaining plates	4.2 (0.165)	31667 90X14
	4.4 (0.173)	31667 90X15
	4.6 (0.181)	31667 90X16
	4.8 (0.189)	31667 90X17
	5.0 (0.197)	31667 90X18
	5.2 (0.205)	31667 90X19

*: Always check with the Parts Department for the latest parts information.

Total End Play

ECS00CDG

Total end play mm (in)	0.25 - 0.55 (0.0098 - 0.0217)
------------------------	-------------------------------

BEARING RACE FOR ADJUSTING TOTAL END PLAY

Thickness mm (in)	Part number*
0.8 (0.031)	31435 95X00
1.0 (0.039)	31435 95X01
1.2 (0.047)	31435 95X02
1.4 (0.055)	31435 95X03
1.6 (0.063)	31435 95X04
1.8 (0.071)	31435 95X05

*: Always check with the Parts Department for the latest parts information.

A
B
AT
D
E
F
G
H
I
J
K
L
M

SERVICE DATA AND SPECIFICATIONS (SDS)
