

A  
B  
C

# SECTION SC

## STARTING & CHARGING SYSTEM

### CONTENTS

<p><b>PRECAUTIONS</b> ..... 2</p> <p>    Precautions for Supplemental Restraint System (SRS) "AIR BAG" and "SEAT BELT PRE-TENSIONER" ..... 2</p> <p>    Wiring Diagrams and Trouble Diagnosis ..... 2</p> <p><b>PREPARATION</b> ..... 3</p> <p>    Special Service Tool ..... 3</p> <p>    Commerical Service Tools ..... 3</p> <p><b>BATTERY</b> ..... 4</p> <p>    How to Handle Battery ..... 4</p> <p>        METHODS OF PREVENTING OVER-DIS-CHARGE ..... 4</p> <p>        CHECKING ELECTROLYTE LEVEL ..... 4</p> <p>        SPECIFIC GRAVITY CHECK ..... 5</p> <p>        CHARGING THE BATTERY ..... 6</p> <p>    Trouble Diagnoses with Battery/Starting/Charging</p> <p>    System Tester ..... 6</p> <p>        DIAGNOSTIC RESULT ITEM CHART ..... 8</p> <p>    Removal and Installation ..... 9</p> <p>        REMOVAL ..... 9</p> <p>        INSTALLATION ..... 9</p> <p><b>STARTING SYSTEM</b> ..... 10</p> <p>    System Description ..... 10</p> <p>    Wiring Diagram — START — ..... 11</p> <p>    Trouble Diagnoses with Battery/Starting/Charging</p> <p>    System Tester ..... 12</p> <p>        DIAGNOSTIC RESULT ITEM CHART ..... 12</p> <p>        WORK FLOW ..... 13</p> <p>        DIAGNOSTIC PROCEDURE 1 ..... 14</p>	<p>        DIAGNOSTIC PROCEDURE 2 ..... 15</p> <p>        MINIMUM SPECIFICATION OF CRANKING VOLTAGE REFERENCING COOLANT TEMPERATURE ..... 16</p> <p>        Removal and Installation ..... 16</p> <p>        REMOVAL ..... 16</p> <p>        INSTALLATION ..... 16</p> <p><b>CHARGING SYSTEM</b> ..... 17</p> <p>    System Description ..... 17</p> <p>    Wiring Diagram — CHARGE — ..... 18</p> <p>    Trouble Diagnoses with Battery/Starting/Charging</p> <p>    System Tester ..... 19</p> <p>        DIAGNOSTIC RESULT ITEM CHART ..... 20</p> <p>        WORK FLOW ..... 21</p> <p>        DIAGNOSTIC PROCEDURE 1 ..... 22</p> <p>        DIAGNOSTIC PROCEDURE 2 ..... 23</p> <p>        DIAGNOSTIC PROCEDURE 3 ..... 23</p> <p>        DIAGNOSTIC PROCEDURE 4 ..... 25</p> <p>        DIAGNOSTIC PROCEDURE 5 ..... 26</p> <p>        MALFUNCTION INDICATOR ..... 27</p> <p>    Removal and Installation ..... 27</p> <p>        REMOVAL ..... 27</p> <p>        INSTALLATION ..... 27</p> <p>    Disassembly and Assembly ..... 28</p> <p><b>SERVICE DATA AND SPECIFICATIONS (SDS)</b> ..... 29</p> <p>    Battery ..... 29</p> <p>    Starter ..... 29</p> <p>    Generator ..... 29</p>
--	--

A  
B  
C  
D  
E  
F  
G  
H  
I  
J  
SC  
L  
M

# PRECAUTIONS

## PRECAUTIONS

PF0:00001

### Precautions for Supplemental Restraint System (SRS) “AIR BAG” and “SEAT BELT PRE-TENSIONER”

EKS008W0

The Supplemental Restraint System such as “AIR BAG” and “SEAT BELT PRE-TENSIONER”, used along with a front seat belt, helps to reduce the risk or severity of injury to the driver and front passenger for certain types of collision. This system includes seat belt switch inputs and dual stage front air bag modules. The SRS system uses the seat belt switches to determine the front air bag deployment, and may only deploy one front air bag, depending on the severity of a collision and whether the front occupants are belted or unbelted. Information necessary to service the system safely is included in the SRS and SB section of this Service Manual.

#### **WARNING:**

- To avoid rendering the SRS inoperative, which could increase the risk of personal injury or death in the event of a collision which would result in air bag inflation, all maintenance must be performed by an authorized NISSAN/INFINITI dealer.
- Improper maintenance, including incorrect removal and installation of the SRS, can lead to personal injury caused by unintentional activation of the system. For removal of Spiral Cable and Air Bag Module, see the SRS section.
- Do not use electrical test equipment on any circuit related to the SRS unless instructed to in this Service Manual. SRS wiring harnesses can be identified by yellow and/or orange harnesses or harness connectors.

### Wiring Diagrams and Trouble Diagnosis

EKS008W1

When you read wiring diagrams, refer to the following:

- [GI-15, "How to Read Wiring Diagrams"](#) .
- [PG-4, "POWER SUPPLY ROUTING CIRCUIT"](#) for power distribution circuit.

When you perform trouble diagnosis, refer to the following:

- [GI-11, "HOW TO FOLLOW TEST GROUPS IN TROUBLE DIAGNOSES"](#).
- [GI-27, "How to Perform Efficient Diagnosis for an Electrical Incident"](#).

# PREPARATION

## PREPARATION

PFP:00002

### Special Service Tool

EKS008W2

A

B

C

D

E

F

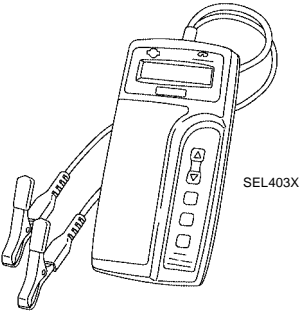
Tool number Tool name	Description
J-44373 Model 620 Battery/Starting/Charging system tester	 <p>SEL403X</p>

### Commerical Service Tools

EKS008W3

G

H

I

J

Tool number Tool name	Description
Power tool	Loosening bolts and nuts

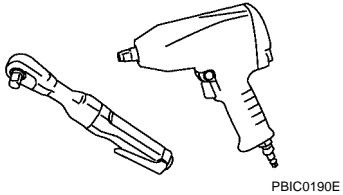

PBIC0190E

SC

L

M

# BATTERY

PFP:AYBGL

## BATTERY

### How to Handle Battery

EKS008W4

#### CAUTION:

- If it becomes necessary to start the engine with a booster battery and jumper cables, use a 12-volt booster battery.
- After connecting battery cables, ensure that they are tightly clamped to battery terminals for good contact.
- Never add distilled water through the hole used to check specific gravity.

#### METHODS OF PREVENTING OVER-DISCHARGE

The following precautions must be taken to prevent over-discharging a battery.

- The battery surface (particularly its top) should always be kept clean and dry.
- The terminal connections should be clean and tight.
- At every routine maintenance, check the electrolyte level. This also applies to batteries designated as "low maintenance" and "maintenance-free".

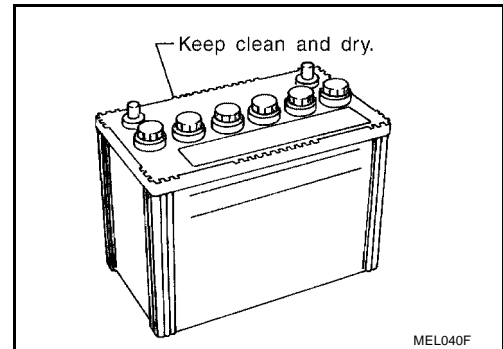

- When the vehicle is not going to be used over a long period of time, disconnect the negative battery terminal.

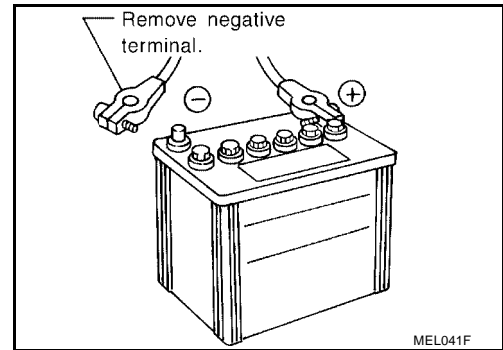

- Check the charge condition of the battery. Periodically check the specific gravity of the electrolyte. Keep a close check on charge condition to prevent over-discharge.

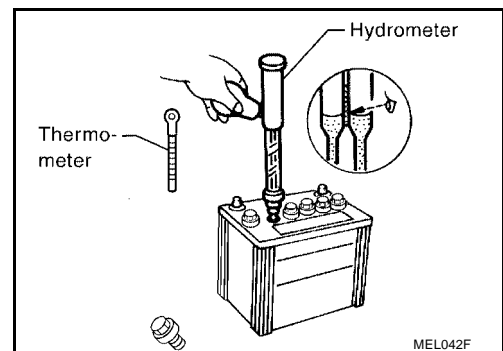

#### CHECKING ELECTROLYTE LEVEL

#### WARNING:

Do not allow battery fluid to come in contact with skin, eyes, fabrics, or painted surfaces. After touching a battery, do not touch or rub your eyes until you have thoroughly washed your hands. If acid contacts eyes, skin or clothing, immediately flush with water for 15 minutes and seek medical attention.

# BATTERY

- Remove the cell plug using a suitable tool.
- Add distilled water up to the MAX level.

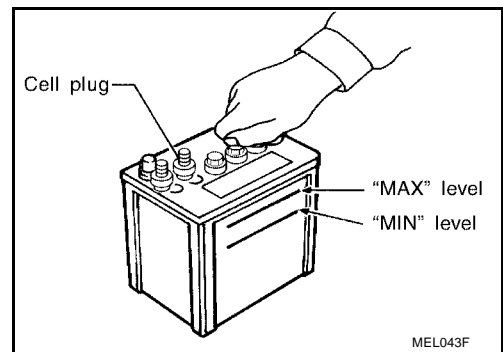

## Sulphation

A battery will be completely discharged if it is left unattended for a long time and the specific gravity will become less than 1.100. This may result in sulphation on the cell plates.

To determine if a battery has been “sulphated”, note its voltage and current when charging it. As shown in the figure, less current and higher voltage are observed in the initial stage of charging sulphated batteries.

A sulphated battery may sometimes be brought back into service by means of a long, slow charge, 12 hours or more, followed by a battery capacity test.

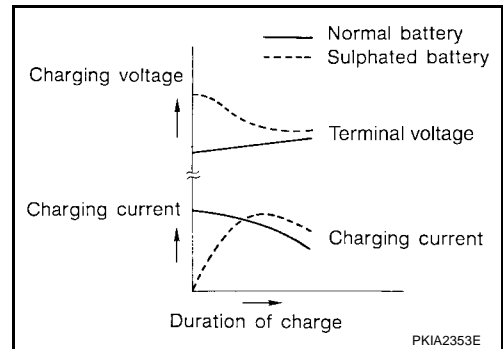

## SPECIFIC GRAVITY CHECK

1. Read hydrometer and thermometer indications at eye level.
2. Use the following chart to correct your hydrometer reading according to electrolyte temperature.

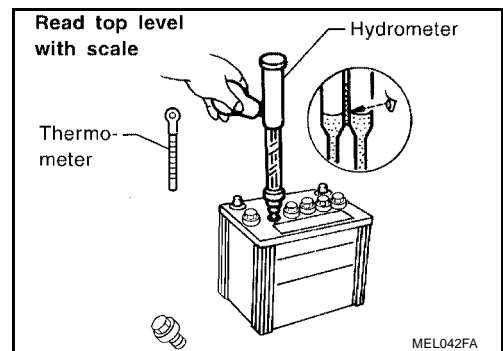

## Hydrometer Temperature Correction

Battery electrolyte temperature °C (°F)	Add to specific gravity reading
71 (160)	0.032
66 (150)	0.028
60 (140)	0.024
54 (130)	0.020
49 (120)	0.016
43 (110)	0.012
38 (100)	0.008
32 (90)	0.004
27 (80)	0
21 (70)	-0.004
16 (60)	-0.008
10 (50)	-0.012
4 (40)	-0.016
-1 (30)	-0.020
-7 (20)	-0.024

A  
B  
C  
D  
E  
F  
G  
H  
I  
J  
SC  
L  
M

# BATTERY

Battery electrolyte temperature °C (°F)	Add to specific gravity reading
-12 (10)	-0.028
-18 (0)	-0.032

Corrected specific gravity	Approximate charge condition
1.260 - 1.280	Fully charged
1.230 - 1.250	3/4 charged
1.200 - 1.220	1/2 charged
1.170 - 1.190	1/4 charged
1.140 - 1.160	Almost discharged
1.110 - 1.130	Completely discharged

## CHARGING THE BATTERY

### CAUTION:

- Do not “quick charge” a fully discharged battery.
- Keep the battery away from open flame while it is being charged.
- When connecting the charger, connect the leads first, then turn on the charger. Do not turn on the charger first, as this may cause a spark.
- If battery electrolyte temperature rises above 55°C (131°F), stop charging. Always charge battery at a temperature below 55°C (131°F).

### Charging Rates

Amps	Time
50	1 hour
25	2 hours
10	5 hours
5	10 hours

Do not charge at more than 50 ampere rate.

### NOTE:

The ammeter reading on your battery charger will automatically decrease as the battery charges. This indicates that the voltage of the battery is increasing normally as the state of charge improves. The charging amps indicated above refer to initial charge rate.

- If, after charging, the specific gravity of any two cells varies more than 0.050, the battery should be replaced.

## Trouble Diagnoses with Battery/Starting/Charging System Tester

EKS008W5

### CAUTION:

When working with batteries, always wear appropriate eye protection.

### NOTE:

- To ensure a complete and thorough diagnosis, the battery, starter and generator test segments must be done as a set from start to finish.
- If battery surface charge is detected while testing, the tester will prompt you to turn on the headlights to remove the surface charge.
- If necessary, the tester will prompt you to determine if the battery temperature is above or below 0°C (32°F). Choose the appropriate selection by pressing the up or down arrow button, then press “ENTER” to make the selection.

# BATTERY

1. Turn off all loads on the vehicle electrical system. Clean or repair as necessary.
2. Visually inspect the battery, battery terminals and cable ends with ignition switch in "OFF" position.

**NOTE:**

The contact surface between the battery terminals, cable ends and tester leads must be clean for a valid test. A poor connection will prevent testing and a "CHECK CONNECTION" message will appear during the test procedures. If this occurs, clean the battery post and terminals, reconnect them and restart the test.

3. Connect the red tester lead clamp to the positive battery terminal, and the black to the negative terminal.
4. The tester will turn on automatically. Using the arrow keys, select "IN-VEHICLE" on the tester and then press the "ENTER" key.

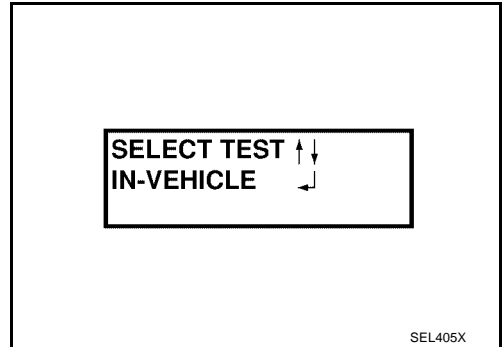
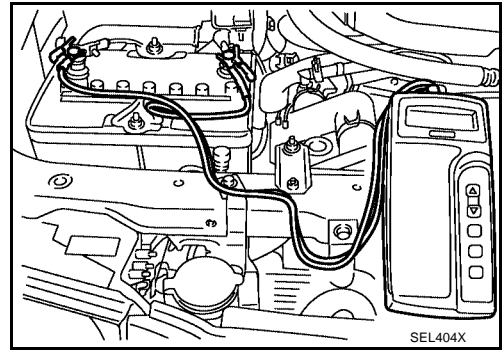

5. Locate the battery type and rating stamped or written on the top case of the battery to be tested.

**NOTE:**

The battery type and rating will have either of the following.

**CCA:** Cold Cranking Amps (490 CCA, 550 CCA, etc.)

**JIS:** Japanese Industrial Standard.

Battery is stamped with a number such as:

80D26L: 80 (rank of output), D (physical size-depth), 26 (width in cm). The last character L (post configuration) is not input into the tester.

The tester requires the rating for the battery be entered exactly as it is written or stamped on the battery. Do not attempt a CCA conversion for JIS stamped batteries. JIS must be input directly.

6. Using the arrow and "ENTER" keys alternately, select the battery type and rating.

**NOTE:**

The tester lists five choices; CCA, JIS, IEC, DIN, and EN. Only use CCA or JIS.

7. Press "ENTER" to begin the test. Diagnosis results are displayed on the tester. Refer to [SC-12, "DIAGNOSTIC RESULT ITEM CHART"](#).

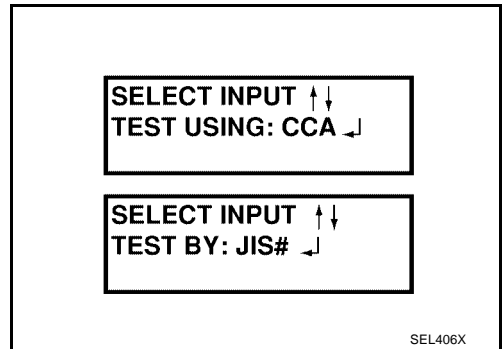

A  
B  
C  
D  
E  
F  
G  
H  
I  
J  
SC  
L  
M

# BATTERY

8. Press "ENTER", then test output code is displayed. Record the test output code on the repair order.
9. Toggle back to the "DIAGNOSTIC SCREEN" for test results.

**NOTE:**

- If necessary, the tester will ask the user to determine if the battery has just been charged. Choose the appropriate selection by pressing the up or down arrow button and then press the "ENTER" button to make the selection.
- When testing a battery installed in a vehicle that has recently been driven, select "BEFORE CHARGE".
- If the battery has just been slow charged due to a "CHARGE & RETEST" decision by the tester, and the tester asks the user "BEFORE CHARGE/AFTER CHARGE", select "AFTER CHARGE".

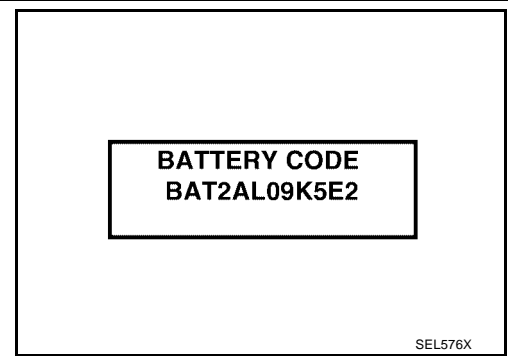

## DIAGNOSTIC RESULT ITEM CHART

Diagnostic item	Service procedure
GOOD BATTERY	Battery is OK. Refer to <a href="#">SC-12. "Trouble Diagnoses with Battery/Starting/Charging System Tester"</a> .
REPLACE BATTERY	Replace battery. Before replacing battery, clean the battery cable clamps and battery posts. Perform battery test again with Battery/Starting/Charging system tester. If second test result is "Replace Battery", then do so. Perform battery test again to confirm repair.
BAD CELL-REPLACE	Replace the battery. Perform battery test again with Battery/Starting/Charging system tester to confirm repair.
GOOD-RECHARGE	Perform the slow battery charging procedure. (Initial rate of charge is 10A for 12 hours.) Perform battery test again with Battery/Starting/Charging system tester.
CHARGE & RETEST	Perform the slow battery charging. (Initial rate of charge is 10A for 12 hours.) Perform battery test again with Battery/Starting/Charging system tester to confirm repair. <b>NOTE:</b> If the tester asks the user "BEFORE CHARGE/AFTER CHARGE", select "AFTER CHARGE".



# BATTERY

EKS008W6

## Removal and Installation

### REMOVAL

1. Disconnect negative battery terminal and positive battery terminal.

**CAUTION:**

**When removing, remove negative battery terminal first.**

2. Remove battery cover.
3. Remove battery clamp bolt and battery clamp.
4. Remove battery.

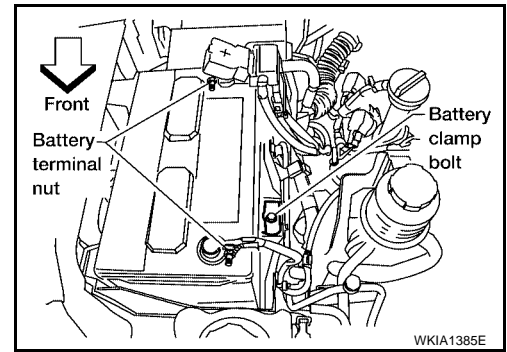

### INSTALLATION

Install in the reverse order of removal.

**CAUTION:**

**When installing, install positive battery terminal first.**

**Battery clamp bolt : 3.5 N·m (0.36 kg-m, 31 in-lb)**

**Battery terminal nut : 3.5 N·m (0.36 kg-m, 31 in-lb)**

A  
B  
C  
D  
E  
F  
G  
H  
I  
J  
SC  
L  
M

# STARTING SYSTEM

---

## STARTING SYSTEM

PFP:23300

### System Description

EKS008W7

Power is supplied at all times:

- through 40A fusible link (letter **m** , located in the fuse and fusible link box)
- to ignition switch terminal B.

With the ignition switch in the START position, power is supplied:

- from ignition switch terminal ST
- to IPDM E/R terminal 21.

With the ignition switch in the ON or START position, power is supplied to IPDM E/R (intelligent power distribution module engine room) CPU.

With the selector lever in the P or N position, power is supplied:

- through A/T assembly terminal 9
- to IPDM E/R terminal 48.

Ground is supplied at all times:

- to IPDM E/R terminals 38 and 59
- from body grounds E9, E15 and E24.

Then the starter relay is turned on.

The IPDM E/R is energized and power is supplied:

- from terminal 19 of the IPDM E/R
- to terminal 1 of the starter motor windings.

The starter motor plunger closes and provides a closed circuit between the battery and the starter motor. The starter motor is grounded to the cylinder block. With power and ground supplied, the starter motor operates.

# STARTING SYSTEM

## Wiring Diagram — START —

EKS008W8

SC-START-01

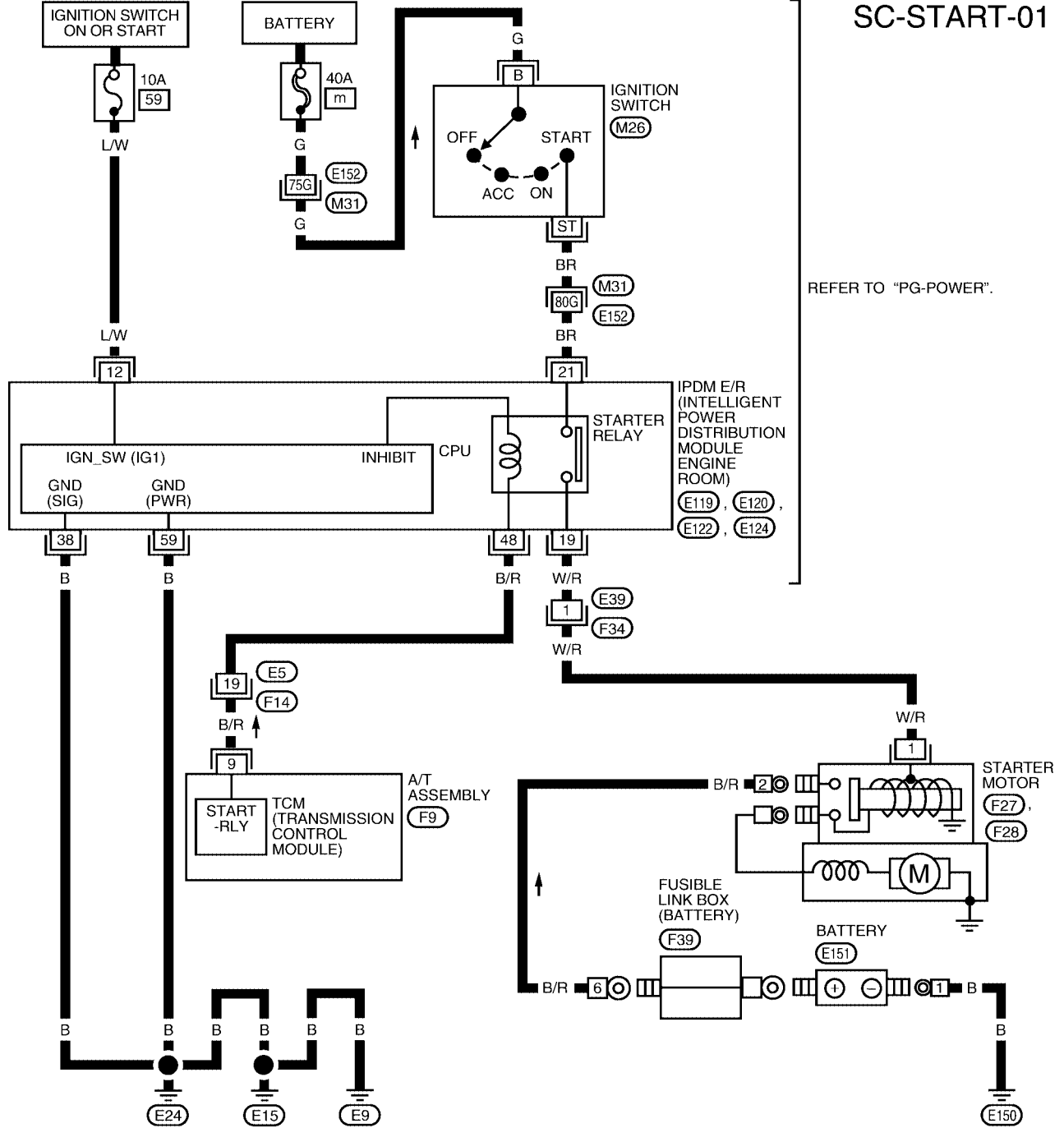

REFER TO "PG-POWER".

A  
B  
C  
D  
E  
F  
G  
H  
I  
J  
K  
L  
M

SC

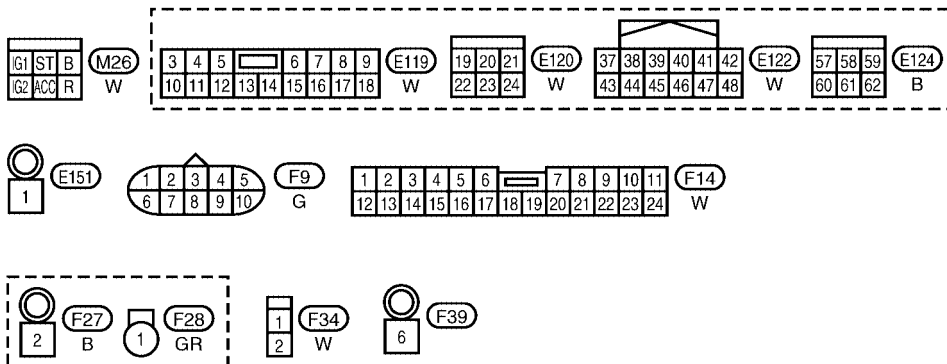

REFER TO THE FOLLOWING.  
(M31) - SUPER MULTIPLE JUNCTION (SMJ)

WKWA1150E

# STARTING SYSTEM

## Trouble Diagnoses with Battery/Starting/Charging System Tester

EKS008W9

### NOTE:

To ensure a complete and thorough diagnosis, the battery, starter and generator test segments must be done as a set from start to finish.

1. Turn off all loads on the vehicle electrical system.
2. Perform battery test with Battery/Starting/Charging system tester. Refer to [SC-12, "Trouble Diagnoses with Battery/Starting/Charging System Tester"](#) .
3. Press "ENTER" to begin the starting system test.

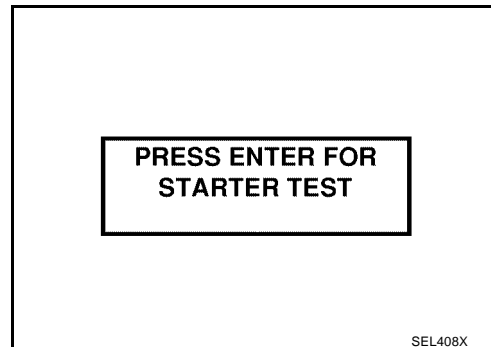

4. Start the engine.

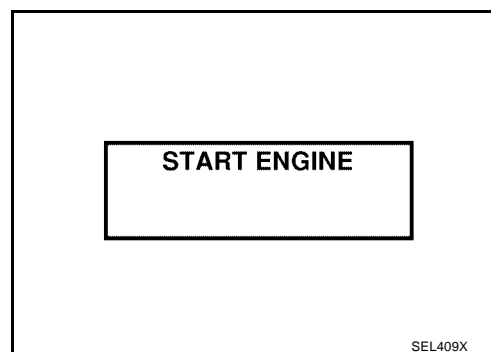

5. Diagnosis result is displayed on the tester. Refer to [SC-12, "DIAGNOSTIC RESULT ITEM CHART"](#) .

### NOTE:

- If the starter performs normally but the engine does not start, perform engine diagnosis.
- For intermittent "NO CRANK" or "NO STARTER OPERATION" incidents, refer to [SC-15, "DIAGNOSTIC PROCEDURE 2"](#) .

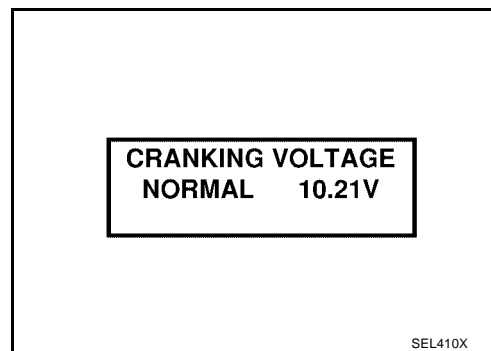

### DIAGNOSTIC RESULT ITEM CHART

Diagnostic item	Service procedure
CRANKING VOLTAGE NORMAL	Go to <a href="#">SC-13, "WORK FLOW"</a> .
CRANKING VOLTAGE LOW	Go to <a href="#">SC-13, "WORK FLOW"</a> .
CHARGE BATTERY	Perform the slow battery charging procedure. (Initial rate of charge is 10A for 12 hours.) Perform battery test again with Battery/Starting/Charging system tester. Refer to <a href="#">SC-12, "Trouble Diagnoses with Battery/Starting/Charging System Tester"</a> .
REPLACE BATTERY	Before replacing battery, clean the battery cable clamps and battery posts. Perform battery test again with Battery/Starting/Charging system tester. Refer to <a href="#">SC-12, "Trouble Diagnoses with Battery/Starting/Charging System Tester"</a> . If second test result is "REPLACE BATTERY", then do so. Perform battery test again to confirm repair.

# STARTING SYSTEM

## WORK FLOW

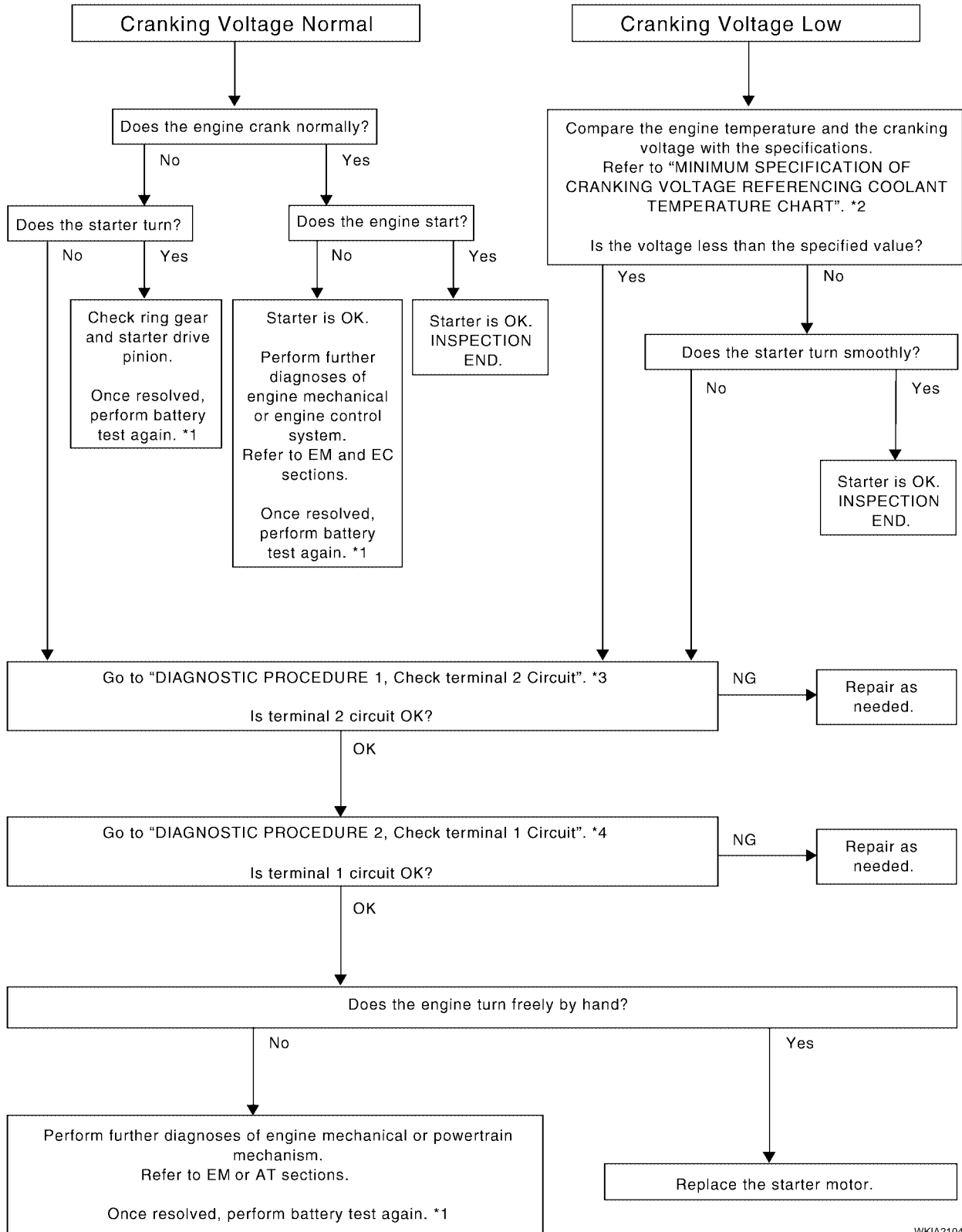

\*1 [SC-12](#)

\*2 [SC-14](#)

\*3 [SC-15](#)

\*4 [SC-15](#)

WKIA2104E

# STARTING SYSTEM

## DIAGNOSTIC PROCEDURE 1

### Check Terminal "2" Circuit

#### 1. CHECK POWER SUPPLY FOR STARTER MOTOR "2" TERMINAL

1. Remove the fuel pump fuse.
2. Crank or start the engine (where possible) until the fuel pressure is released.
3. Turn the ignition switch OFF.
4. Check that the starter motor connector F27 connection is clean and tight.
5. Check voltage between starter motor connector F27 terminal 2 (B/R) and ground using a digital circuit tester.

**Battery voltage should exist.**

OK or NG

OK >> GO TO 2.

NG >> Check harness between the battery and the starter motor for open circuit.

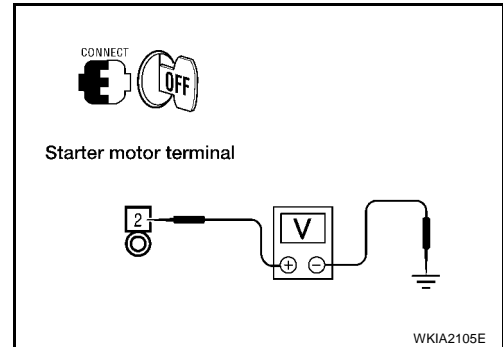

#### 2. CHECK BATTERY CABLE CONNECTION QUALITY (VOLTAGE DROP TEST)

Check voltage between starter motor connector F27 terminal 2 (B/R) and battery positive terminal using a digital circuit tester.

**Ignition switch in START. : Less than 0.5V**

OK or NG

OK >> GO TO 3.

NG >> Check harness between the battery and the starter motor for poor continuity.

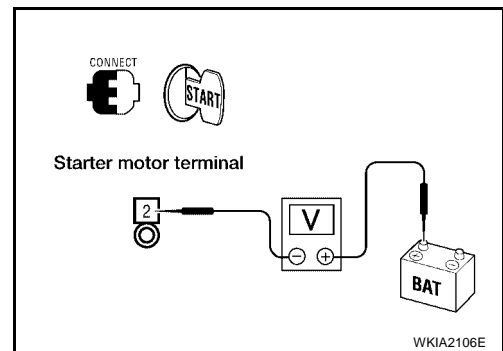

#### 3. CHECK STARTER MOTOR GROUND CIRCUIT (VOLTAGE DROP TEST)

Check voltage between starter motor case and battery negative terminal using a digital circuit tester.

**Ignition switch in START. : Less than 0.2V**

OK or NG

OK >> Starter motor "2" terminal circuit is OK. Further inspection is necessary. Refer to [SC-13, "WORK FLOW"](#).

NG >> Check harness between the starter motor case and ground for poor continuity.

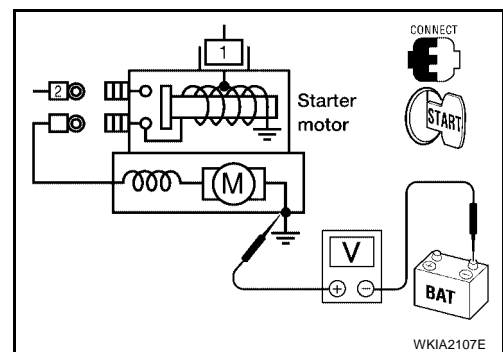

# STARTING SYSTEM

## DIAGNOSTIC PROCEDURE 2

### Check Terminal "1" Circuit

#### 1. CHECK POWER SUPPLY FOR STARTER MOTOR "1" TERMINAL

1. Remove the fuel pump fuse.
2. Crank or start the engine (where possible) until the fuel pressure is released.
3. Turn the ignition switch OFF.
4. Disconnect starter motor connector F28.
5. Check voltage between starter motor connector F28 terminal 1 (W/R) and ground using a digital circuit tester.

**Ignition switch in START.** : **Battery voltage**

OK or NG

OK >> GO TO 2.

NG >> Check the following.

- 40A fusible link (letter **m** , located in fuse and fusible link box)
- Ignition switch
- Starter relay [within the intelligent power distribution module engine room (IPDM E/R)]
- Harness for open or short

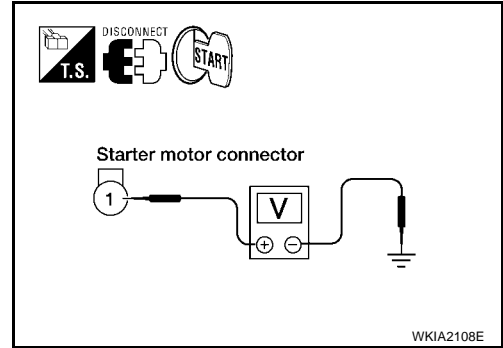

#### 2. CHECK "1" TERMINAL CONNECTION QUALITY (VOLTAGE DROP TEST)

1. Turn the ignition switch OFF.
2. Connect starter motor connector F28.
3. Check voltage between starter motor connector F28 terminal 1 (W/R) and battery positive terminal using a digital circuit tester.

**Ignition switch in START.** : **Less than 1V**

OK or NG

OK >> Starter motor "1" terminal circuit is OK. Further inspection is necessary. Refer to [SC-13, "WORK FLOW"](#) .

NG >> Check harness between the battery and the starter motor "1" terminal for poor continuity.

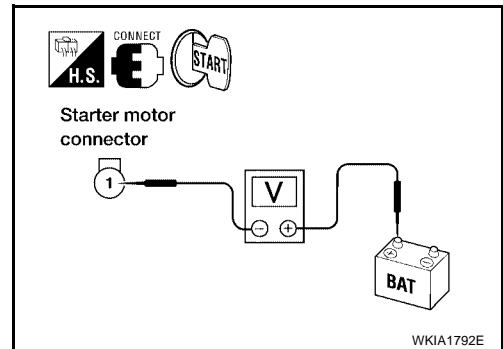

# STARTING SYSTEM

## MINIMUM SPECIFICATION OF CRANKING VOLTAGE REFERENCING COOLANT TEMPERATURE

Engine coolant temperature	Voltage V
-30°C to -20°C (-22°F to -4°F)	8.4
-19°C to -10°C (-2°F to 14°F)	8.9
-9°C to 0°C (16°F to 32°F)	9.3
More than 1°C (More than 34°F)	9.7

## Removal and Installation

EKS008WA

### REMOVAL

1. Remove the intake manifold. Refer to [EM-15, "REMOVAL"](#).
2. Disconnect the starter harness connectors.
3. Remove the two starter bolts, using power tools.
4. Remove the starter.

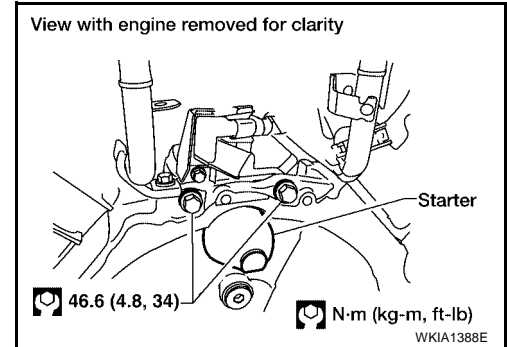

### INSTALLATION

To install, reverse the removal procedure.

### CAUTION:

Be sure to tighten terminal "2" nut carefully.

Terminal "2" nut : 10.8 N·m (1.1 kg-m, 8 ft-lb)



# CHARGING SYSTEM

## CHARGING SYSTEM

PFP:23100

### System Description

EKS008WB

The generator provides DC voltage to operate the vehicle's electrical system and to keep the battery charged. The voltage output is controlled by the IC regulator.

Power is supplied at all times to generator terminal 4 through:

- 10A fuse (No. 30, located in the fuse and fusible link box).

Terminal 1 supplies power to charge the battery and operate the vehicle's electrical system. Output voltage is controlled by the IC regulator at terminal 4 detecting the input voltage. The charging circuit is protected by the 140A fusible link (letter **a** , located in the fusible link box).

Ground is supplied:

- to generator terminal 2
- through body ground E203.

With the ignition switch in the ON or START position, power is supplied:

- through 10A fuse [No. 14, located in the fuse block (J/B)]
- to combination meter terminal 24 for the charge warning lamp.

Ground is supplied to terminal 13 of the combination meter through terminal 3 of the generator. With power and ground supplied, the charge warning lamp will illuminate. When the generator is providing sufficient voltage with the engine running, the ground is opened and the charge warning lamp will go off.

If the charge warning lamp illuminates with the engine running, a fault is indicated.

A

B

C

D

E

F

G

H

I

J

SC

L

M

# CHARGING SYSTEM

## Wiring Diagram — CHARGE —

EKS008WC

### SC-CHARGE-01

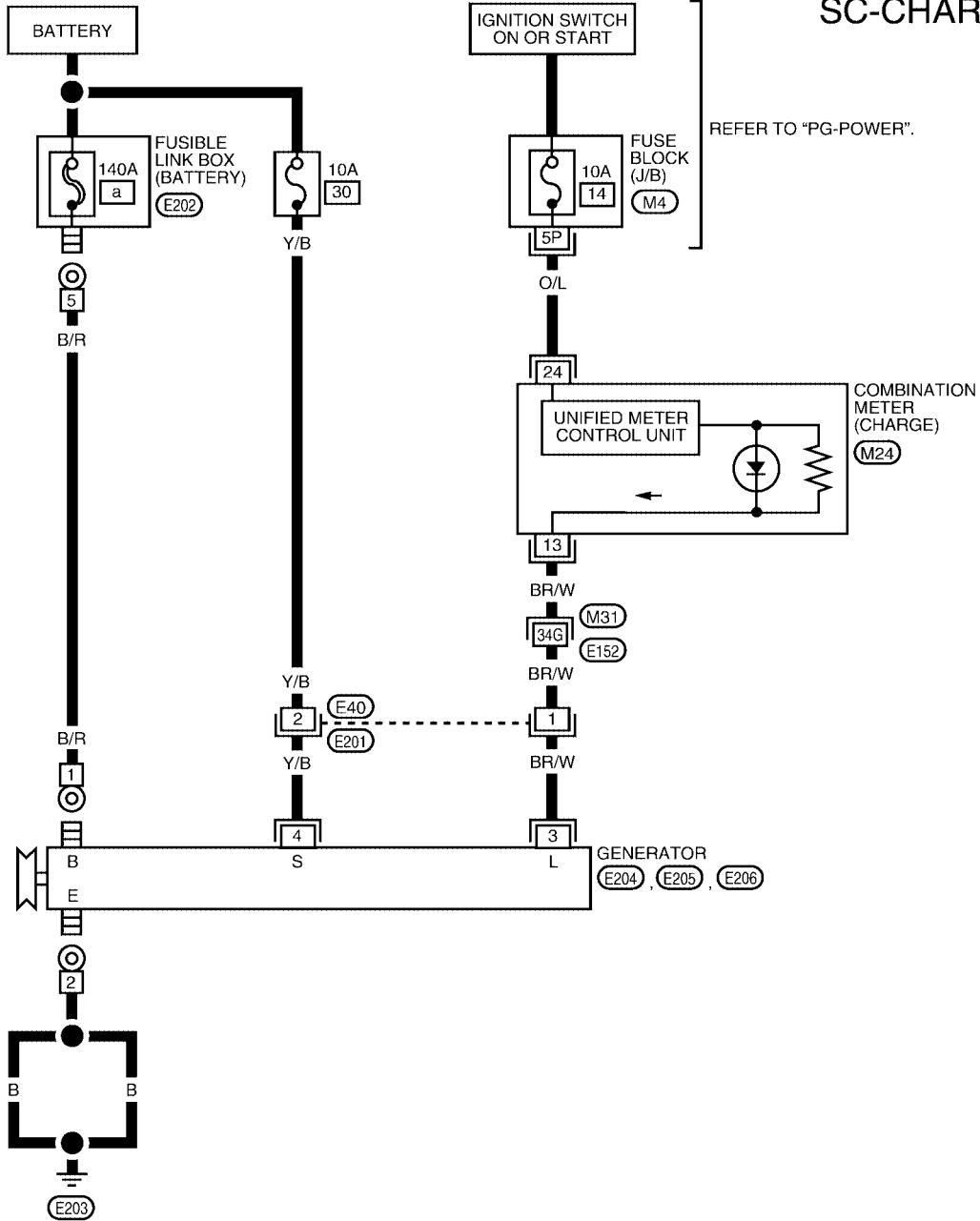

1P	2P	3P	4P	5P	6P	7P	M4	1	2	3	4	5	6	7	8	9	10	11	12	13	14	15	16	17	18	19	20	M24		
8P	9P	10P	11P	12P	13P	14P	15P	16P	W	21	22	23	24	25	26	27	28	29	30	31	32	33	34	35	36	37	38	39	40	W

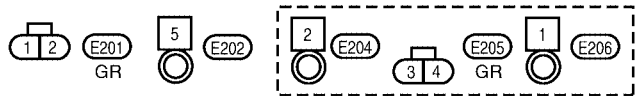

REFER TO THE FOLLOWING.

(M31) - SUPER MULTIPLE JUNCTION (SMJ)

WKWA1140E

# CHARGING SYSTEM

## Trouble Diagnoses with Battery/Starting/Charging System Tester

EKS008WD

### NOTE:

To ensure a complete and thorough diagnosis, the battery, starter and generator test segments must be done as a set from start to finish.

1. Turn off all loads on the vehicle electrical system.
2. Perform battery and starting system test with Battery/Starting/Charging system tester.
3. Press "ENTER" to begin the charging system test.
4. Start engine.

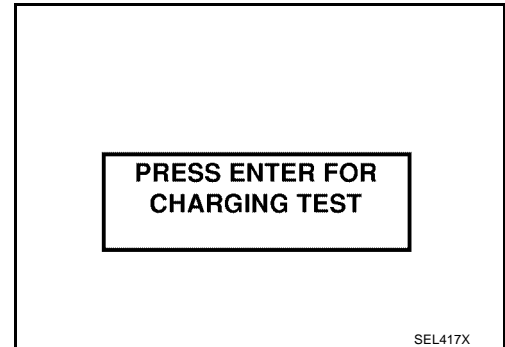

5. Press "ENTER" until "LOADS OFF REV ENGINE 5 SEC" is displayed.
6. Raise and hold the engine speed at 1,500 to 2,000 rpm for about 5 seconds, then return the engine to idle. Once the increase in engine rpm is detected, press "ENTER" to continue.

### NOTE:

- If after 30 seconds an increase in engine idle speed is not detected, "RPM NOT DETECTED" will display.
- Some engines may have a higher idle initially after starting, particularly when the engine is cold. The tester may detect this without any other action being taken. If this occurs, continue on with the testing process. The final results will not be affected.

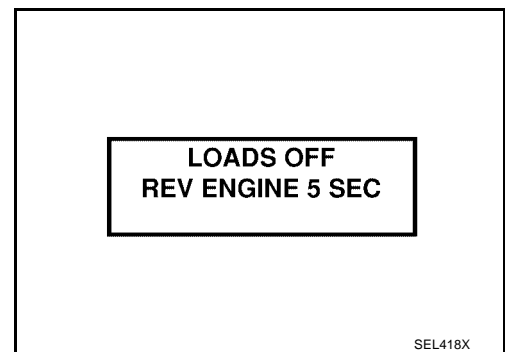

7. The tester now checks the engine at idle and performs the DIODE/RIPPLE check.
8. When complete, the tester will prompt you to turn on the following electrical loads.
  - Heater fan set to highest speed. Do not run the A/C or windshield defroster.
  - Headlamp high beam
  - Rear window defogger

### NOTE:

Do not run the windshield wipers or any other cyclical loads.

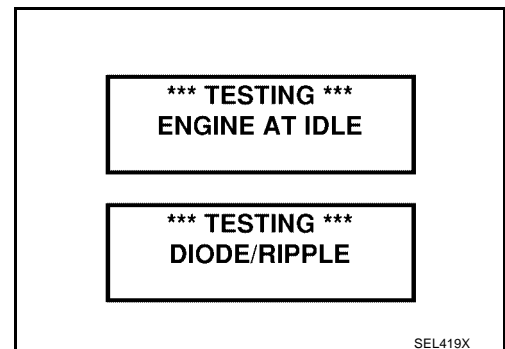

9. Press "ENTER" to continue.

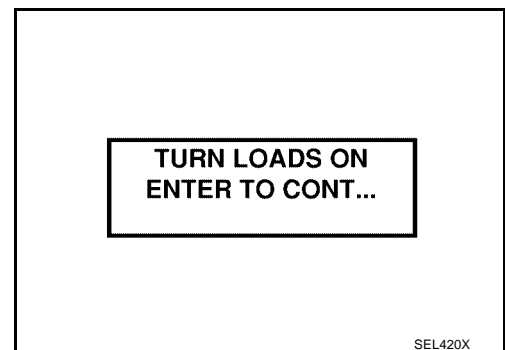

A  
B  
C  
D  
E  
F  
G  
H  
I  
J  
SC  
L  
M

# CHARGING SYSTEM

10. Raise and hold the engine speed at 1,500 to 2,000 rpm for about 5 seconds, then return the engine to idle. Once the increase in engine rpm is detected, press "ENTER" to continue.

**NOTE:**

If after 30 seconds an increase in engine idle speed is not detected, "RPM NOT DETECTED" will be displayed. Press "ENTER" to restart the test.

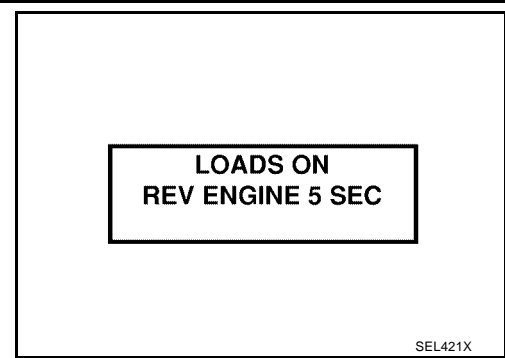

11. Diagnostic result is displayed on the tester. Refer to [SC-20, "DIAGNOSTIC RESULT ITEM CHART"](#) .

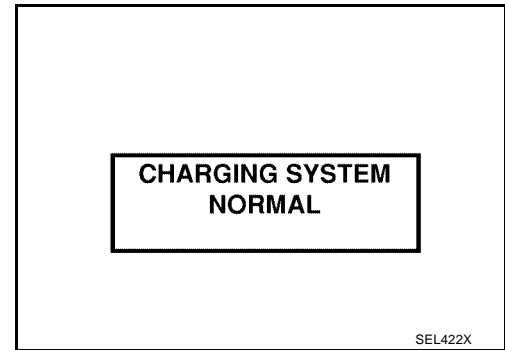

12. Press "ENTER" then test output code is displayed. Record the test output code on the repair order.  
 13. Toggle back to the "DIAGNOSTIC SCREEN" for test results.

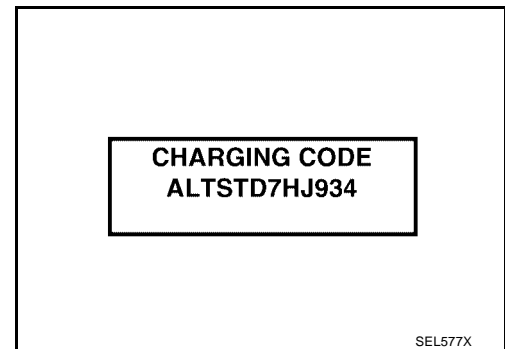

## DIAGNOSTIC RESULT ITEM CHART

Diagnostic item	Service procedure
CHARGING SYSTEM NORMAL	Charging system is normal and will also show DIODE RIPPLE test result.
NO CHARGING VOLTAGE	Go to <a href="#">SC-21, "WORK FLOW"</a> .
LOW CHARGING VOLTAGE	Go to <a href="#">SC-21, "WORK FLOW"</a> .
HIGH CHARGING VOLTAGE	Go to <a href="#">SC-21, "WORK FLOW"</a> .
DIODE RIPPLE NORMAL	Diode ripple is OK and will also show CHARGING VOLTAGE test result.
EXCESS RIPPLE DETECTED	Replace the generator. Perform "DIODE RIPPLE" test again using Battery/Starting/Charging system tester to confirm repair.
DIODE RIPPLE NOT DETECTED	Go to <a href="#">SC-21, "WORK FLOW"</a> .

# CHARGING SYSTEM

## WORK FLOW

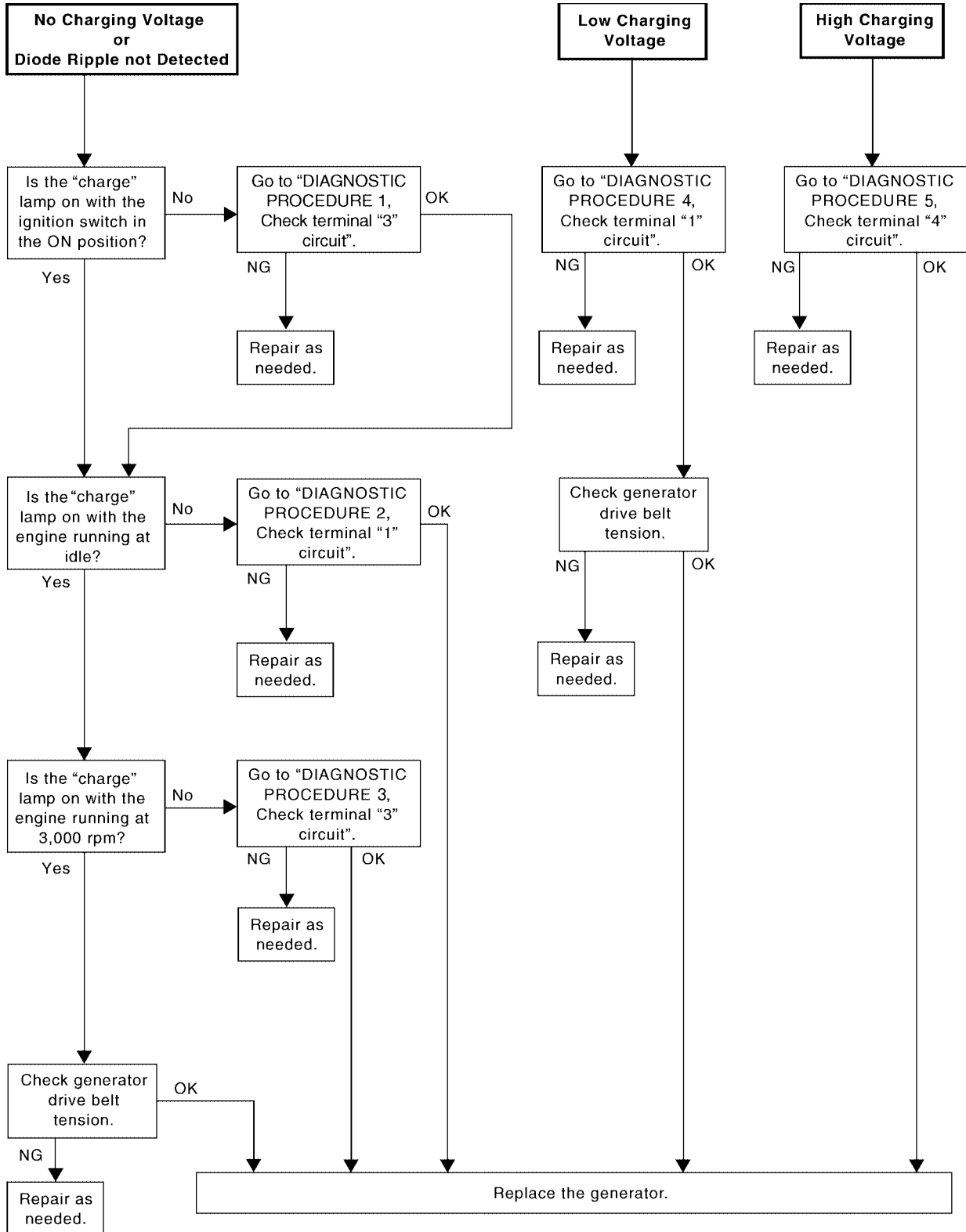

A  
B  
C  
D  
E  
F  
G  
H  
I  
J  
SC  
L  
M

WKIA2109E

# CHARGING SYSTEM

## DIAGNOSTIC PROCEDURE 1

### Check Terminal "3" Circuit

#### 1. CHECK "3" TERMINAL CONNECTION

1. Turn the ignition switch OFF.
2. Check to see if "3" terminal is clean and tight.

OK or NG

OK >> GO TO 2.

NG >> Repair "3" terminal connection. Confirm repair by performing complete Battery/Starting/Charging system test.

#### 2. CHECK "3" TERMINAL CIRCUIT

1. Disconnect E205 connector from generator.
2. Apply ground to connector E205 terminal 3 (BR/W) with the ignition switch in the ON position.

**CHARGE lamp should light up.**

OK or NG

OK >> GO TO [SC-21, "WORK FLOW"](#) .

NG >> Check the following.

- 10A fuse [No. 14, located in fuse block (J/B)]
- CHARGE lamp
- Harness for open or short between combination meter and fuse
- Harness for open or short between combination meter and generator

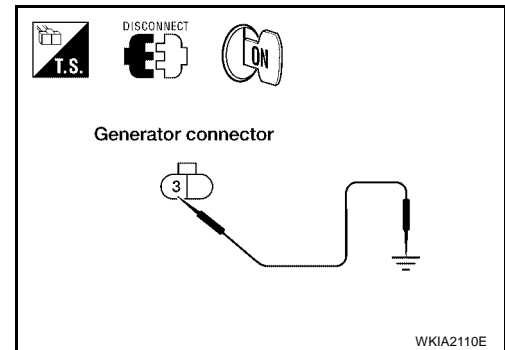

# CHARGING SYSTEM

## DIAGNOSTIC PROCEDURE 2

### Check Terminal "1" Circuit

#### 1. CHECK "1" TERMINAL CONNECTION

1. Turn the ignition switch OFF.
2. Check to see if "1" terminal is clean and tight.

OK or NG

OK >> GO TO 2.

NG >> Repair "1" terminal connection. Confirm repair by performing complete Battery/Starting/Charging system test.

#### 2. CHECK GENERATOR "1" TERMINAL CIRCUIT

Check voltage between generator connector E206 terminal 1 (B/R) and ground using a digital circuit tester.

**Battery voltage should exist.**

OK or NG

OK >> GO TO 3.

NG >> Check the following.

- 140A fusible link (letter **a** , located in fusible link box)
- Harness for open or short between generator and fusible link

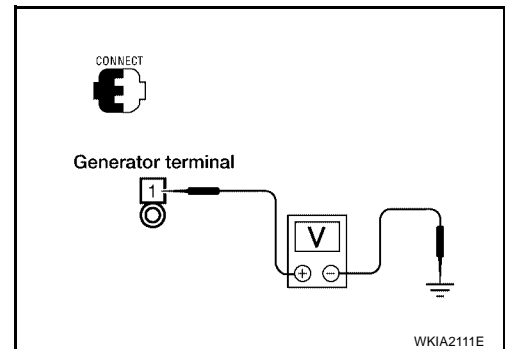

#### 3. CHECK "1" TERMINAL CONNECTION QUALITY (VOLTAGE DROP TEST)

Check voltage between generator connector E206 terminal 1 (B/R) and battery positive terminal using a digital circuit tester.

**With engine running : Less than 0.2V at idle and warm.**

OK or NG

OK >> Replace the generator. Refer to [SC-27, "Removal and Installation"](#) . Confirm repair by performing complete Battery/Starting/Charging system test.

NG >> Check harness between the battery and the generator for poor continuity.

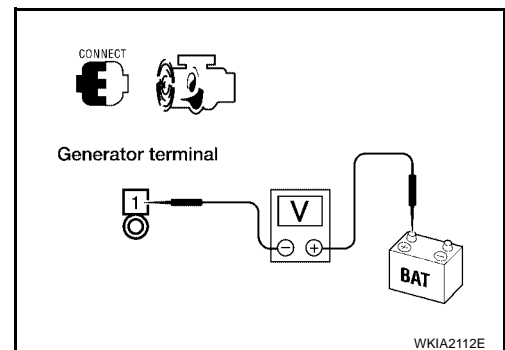

## DIAGNOSTIC PROCEDURE 3

### Check Terminal "3" Circuit

#### 1. CHECK "3" TERMINAL CONNECTION

1. Turn the ignition switch OFF.
2. Check to see if "3" terminal is clean and tight.

OK or NG

OK >> GO TO 2.

NG >> Repair "3" terminal connection. Confirm repair by performing complete Battery/Starting/Charging system test.

# CHARGING SYSTEM

## 2. CHECK "3" TERMINAL CIRCUIT

1. Disconnect E205 connector from generator.
2. Apply ground to connector E205 terminal 3 (BR/W) with the ignition switch in the ON position.

**CHARGE lamp should light up.**

### OK or NG

- OK >> Replace the generator. Refer to [SC-27, "Removal and Installation"](#) . Confirm repair by performing complete battery/starting/charging system test.
- NG >> Check the following.
- 10A fuse [No. 14, located in fuse block (J/B)]
  - CHARGE lamp
  - Harness for open or short between combination meter and fuse
  - Harness for open or short between combination meter and generator

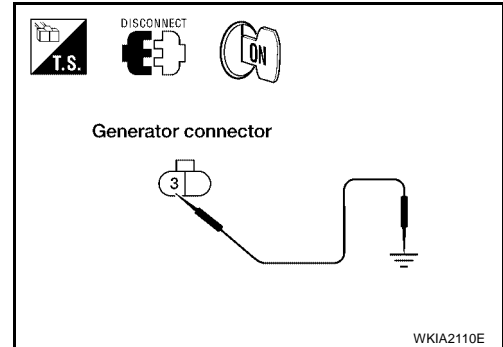



# CHARGING SYSTEM

## DIAGNOSTIC PROCEDURE 4

### Check Terminal "1" Circuit

#### 1. CHECK "1" TERMINAL CONNECTION

1. Turn the ignition switch OFF.
2. Check to see if "1" terminal is clean and tight.

OK or NG

OK >> GO TO 2.

NG >> Repair "1" terminal connection. Confirm repair by performing complete Battery/Starting/Charging system test.

#### 2. CHECK GENERATOR "1" TERMINAL CIRCUIT

Check voltage between generator connector E206 terminal 1 (B/R) and ground using a digital circuit tester.

**Battery voltage should exist.**

OK or NG

OK >> GO TO 3.

NG >> Check the following.

- 140A fusible link (letter **a** , located in fusible link box)
- Harness for open or short between generator and fusible link

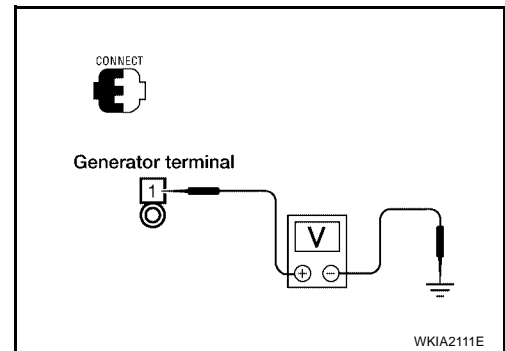

#### 3. CHECK "1" TERMINAL CONNECTION QUALITY (VOLTAGE DROP TEST)

1. Start the engine.
2. Check voltage between generator connector E206 terminal 1 (B/R) and battery positive terminal using a digital circuit tester.

**With engine running : Less than 0.2V  
at idle and warm.**

OK or NG

OK >> GO TO 4.

NG >> Check harness between the battery and the generator for poor continuity.

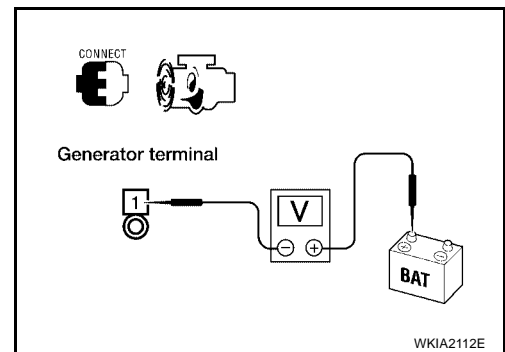

#### 4. CHECK GENERATOR DRIVE BELT TENSION

1. Turn the ignition switch OFF.
2. Check generator drive belt tension. Refer to [EM-12, "DRIVE BELTS"](#) .

OK or NG

OK >> Replace the generator. Refer to [SC-27, "Removal and Installation"](#) . Confirm repair by performing complete Battery/Starting/Charging system test.

NG >> Readjust drive belt tension. Refer to [EM-12, "Tension Adjustment"](#) .

# CHARGING SYSTEM

## DIAGNOSTIC PROCEDURE 5

### Check Terminal "4" Circuit

#### 1. CHECK "4" TERMINAL CONNECTION

1. Turn the ignition switch OFF.
2. Check to see if "4" terminal is clean and tight.

OK or NG

OK >> GO TO 2.

NG >> Repair "4" terminal connection. Confirm repair by performing complete Battery/Starting/Charging system test.

#### 2. CHECK GENERATOR "4" TERMINAL CIRCUIT

Check voltage between generator connector E205 terminal 4 (Y/B) and ground using a digital circuit tester.

**Battery voltage should exist.**

OK or NG

OK >> GO TO 3.

NG >> Check the following.

- 10A fuse (No. 30, located in fuse and fusible link box)
- Harness for open or short between generator and fuse

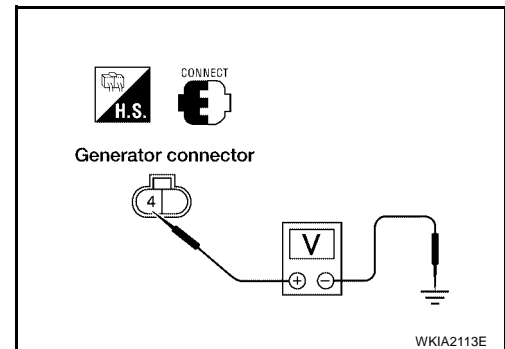

#### 3. CHECK "4" TERMINAL CONNECTION QUALITY (VOLTAGE DROP TEST)

1. Start the engine.
2. Check voltage between generator connector E205 terminal 4 (Y/B) and battery positive terminal using a digital circuit tester.

**With engine running : Less than 0.2V  
at idle and warm.**

OK or NG

OK >> Replace the generator. Refer to [SC-27, "Removal and Installation"](#) . Confirm repair by performing complete Battery/Starting/Charging system test.

NG >> Check harness between the battery and the generator for poor continuity.

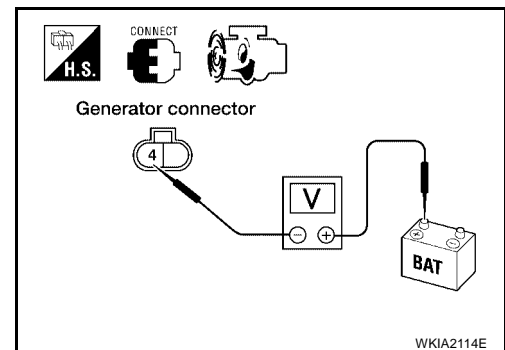

# CHARGING SYSTEM

## MALFUNCTION INDICATOR

The IC regulator warning function activates to illuminate "CHARGE" warning lamp, if any of the following symptoms occur while generator is operating:

- Excessive voltage is produced.
- No voltage is produced.

## Removal and Installation

### REMOVAL

1. Disconnect the negative battery terminal.
2. Remove the fan shroud. Refer to [CO-13, "REMOVAL"](#).
3. Remove the drive belt. Refer to [EM-12, "Removal"](#).
4. Remove lower bracket, using power tools.
5. Remove the generator upper bolt, using power tools.
6. Disconnect the generator harness connectors.
7. Remove the generator.

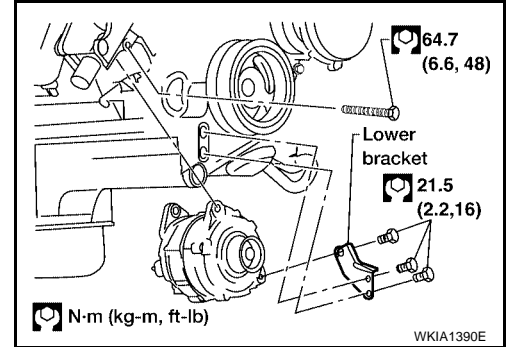

### INSTALLATION

Installation is in the reverse order of removal.

- Install the generator and check tension of drive belt. Refer to [EM-12, "Tension Adjustment"](#).

### CAUTION:

Be sure to tighten terminal "1" nut carefully.

"1" terminal nut

: 10.8 N-m (1.1 kg-m, 8 ft-lb)

# CHARGING SYSTEM

## Disassembly and Assembly

EKS008WF

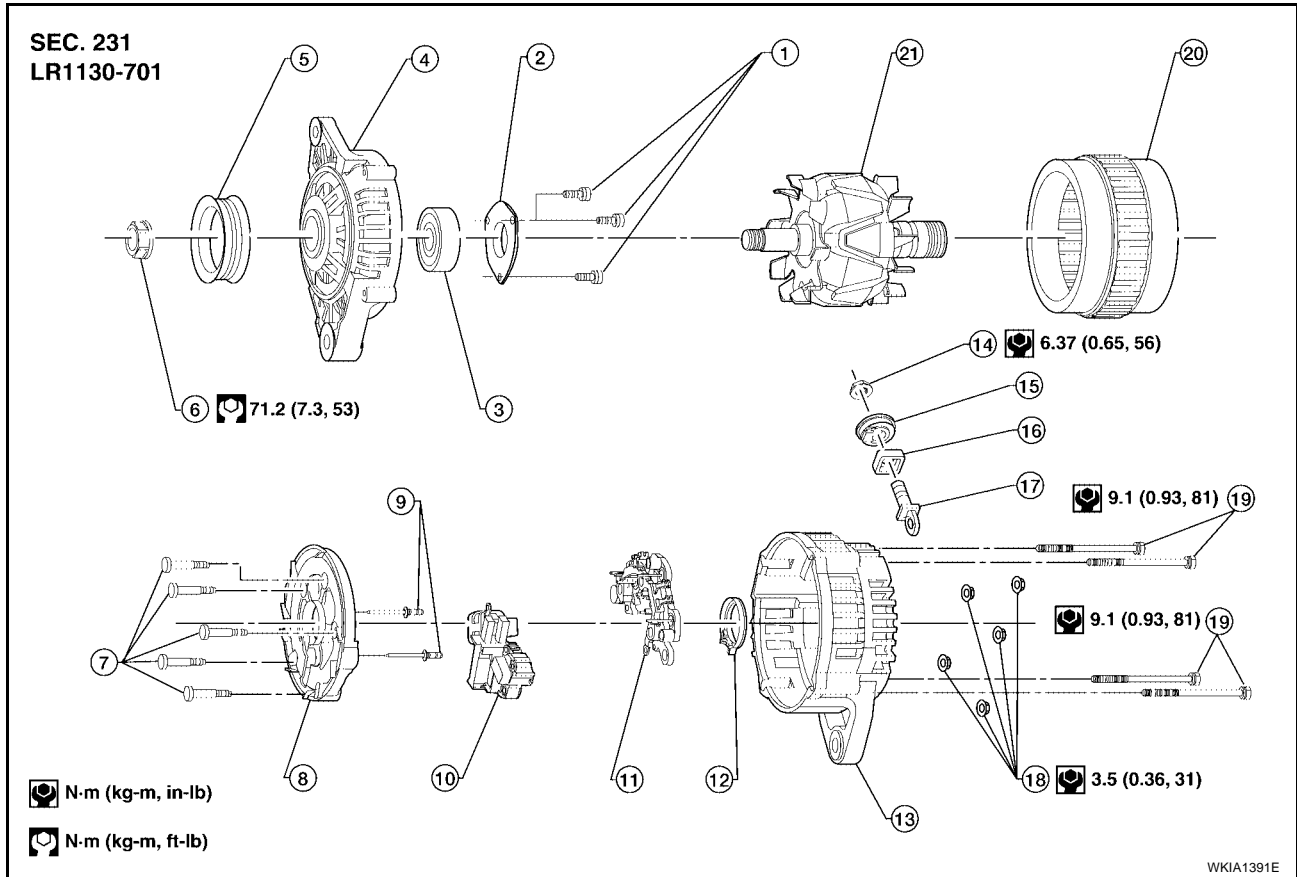

- |                           |                     |                       |
|---------------------------|---------------------|-----------------------|
| 1. Screws                 | 2. Bearing retainer | 3. Front bearing      |
| 4. Front cover            | 5. Pulley           | 6. Pulley nut         |
| 7. Bolts                  | 8. Fan guide        | 9. Rivets             |
| 10. IC regulator assembly | 11. Diode assembly  | 12. Packing           |
| 13. Rear cover            | 14. Nut             | 15. Insulator bushing |
| 16. Bushing               | 17. B terminal      | 18. Nuts              |
| 19. Bolts                 | 20. Stator          | 21. Rotor assembly    |

# SERVICE DATA AND SPECIFICATIONS (SDS)

## SERVICE DATA AND SPECIFICATIONS (SDS)

PF0:00030

### Battery

EKS008WG

	Standard battery	Heavy duty battery
Type	Gr. 24	Gr. 27
Capacity (20 HR) minimum V-AH	72	80
Cold cranking current A (For reference value)	650	710

### Starter

EKS008WH

Application	All models	
Manufacturer	Mitsubishi M002T85571ZCKD	
Type	Reduction gear type	
System voltage	12V	
No-load	Terminal voltage	11V
	Current	Less than 145A
	Revolution	More than 3,300 rpm
Minimum diameter of commutator	31.4 mm (1.236 in)	
Minimum length of brush	11.0 mm (0.433 in)	
Brush spring tension	26.7-36.1 N (2.72 - 3.68 kg, 5.93 - 8.02 lb)	
Clearance between pinion front edge and pinion stopper	0.5 - 2.0 mm (0.020 - 0.079 in)	

### Generator

EKS008WI

Type	LR1130-701
	Hitachi
Nominal rating	12V-130A
Ground polarity	Negative
Minimum revolution under no-load (When 13.5 volts is applied)	1,200 rpm
Hot output current (When 13.5 volts is applied)	More than 78A/1,800 rpm More than 108A/2,500 rpm More than 130A/5,000 rpm
Regulated output voltage	14.1 - 14.7V @ 25°C
Minimum length of brush	6 mm (0.24 in)
Brush spring pressure	1.0 - 3.432 N (0.102 - 0.3501 kg, 0.22 - 0.7715 lbs)
Slip ring minimum outer diameter	26 mm (1.02 in)
Rotor (Field coil) resistance	2.1 ohms

# SERVICE DATA AND SPECIFICATIONS (SDS)

---