

SECTION **RSU**
REAR SUSPENSION

A
B
C
D

RSU

CONTENTS

PRECAUTIONS	2	SHOCK ABSORBER	7	F
Precautions	2	Removal and Installation	7	
PREPARATION	3	REMOVAL	7	G
Commercial Service Tools	3	INSPECTION AFTER REMOVAL	7	
NOISE VIBRATION AND HARSHNESS (NVH)		INSTALLATION	7	
TROUBLESHOOTING	4	LEAF SPRING	8	H
NVH Troubleshooting Chart	4	Removal and Installation	8	
REAR SUSPENSION ASSEMBLY	5	REMOVAL	9	I
Components	5	INSPECTION AFTER REMOVAL	9	
On-Vehicle Inspection and Service	6	INSTALLATION	10	J
		SERVICE DATA AND SPECIFICATIONS (SDS)	11	
		General Specifications (Rear)	11	K
		Wheelarch Height (Unladen*1)	11	L

M

PRECAUTIONS

PRECAUTIONS

PFP:00001

Precautions

EES000ZC

- When installing rubber parts, final tightening must be carried out under unladen condition* with tires on ground.
* Fuel, radiator coolant, and engine oil are full. Spare tire, jack, hand tools, and mats are in their designated positions.

PREPARATION

PREPARATION

PF0:00002

Commercial Service Tools

EES000ZD

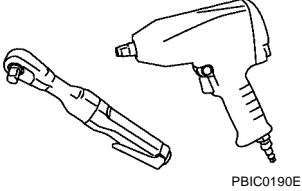
Tool name	Description
<p>Power tool</p>  <p>PBIC0190E</p>	<p>Removing nuts and bolts</p>

A
B
C
D

RSU

F
G
H
I
J
K
L
M

NOISE VIBRATION AND HARSHNESS (NVH) TROUBLESHOOTING

NOISE VIBRATION AND HARSHNESS (NVH) TROUBLESHOOTING

PF5:54000

NVH Troubleshooting Chart

EES000ZE

Use the chart below to help you find the cause of the symptom. If necessary, repair or replace the parts.

Reference page		RSU-5	RSU-7	RSU-5	RSU-5	RSU-8	RSU-5	PR-3, "NVH Troubleshooting Chart"	RFD-8, "NVH Troubleshooting Chart"	RAX-4, "NVH Troubleshooting Chart"	WT-3, "NVH Troubleshooting Chart"	WT-3, "NVH Troubleshooting Chart"	BR-5, "NVH Troubleshooting Chart"	PS-5, "NVH Troubleshooting Chart"
Possible cause and SUSPECTED PARTS		Improper installation, looseness	Shock absorber deformation, damage or deflection	Bushing or mounting deterioration	Parts interference	Spring fatigue	Suspension looseness	PROPELLER SHAFT	REAR FINAL DRIVE	AXLE	TIRES	ROAD WHEEL	BRAKES	STEERING
Symptoms	Noise	x	x	x	x	x	x	x	x	x	x	x	x	x
	Shake	x	x	x	x	x	x	x	x	x	x	x	x	x
	Vibration	x	x	x	x	x	x	x	x	x	x	x	x	x
	Shimmy	x	x	x	x	x	x	x	x	x	x	x	x	x
	Shudder	x	x	x	x	x	x	x	x	x	x	x	x	x
	Poor quality ride or handling	x	x	x	x	x	x	x	x	x	x	x	x	x

x: Applicable

REAR SUSPENSION ASSEMBLY

REAR SUSPENSION ASSEMBLY

Components

PFP:55020

EES000ZF

SEC. 431

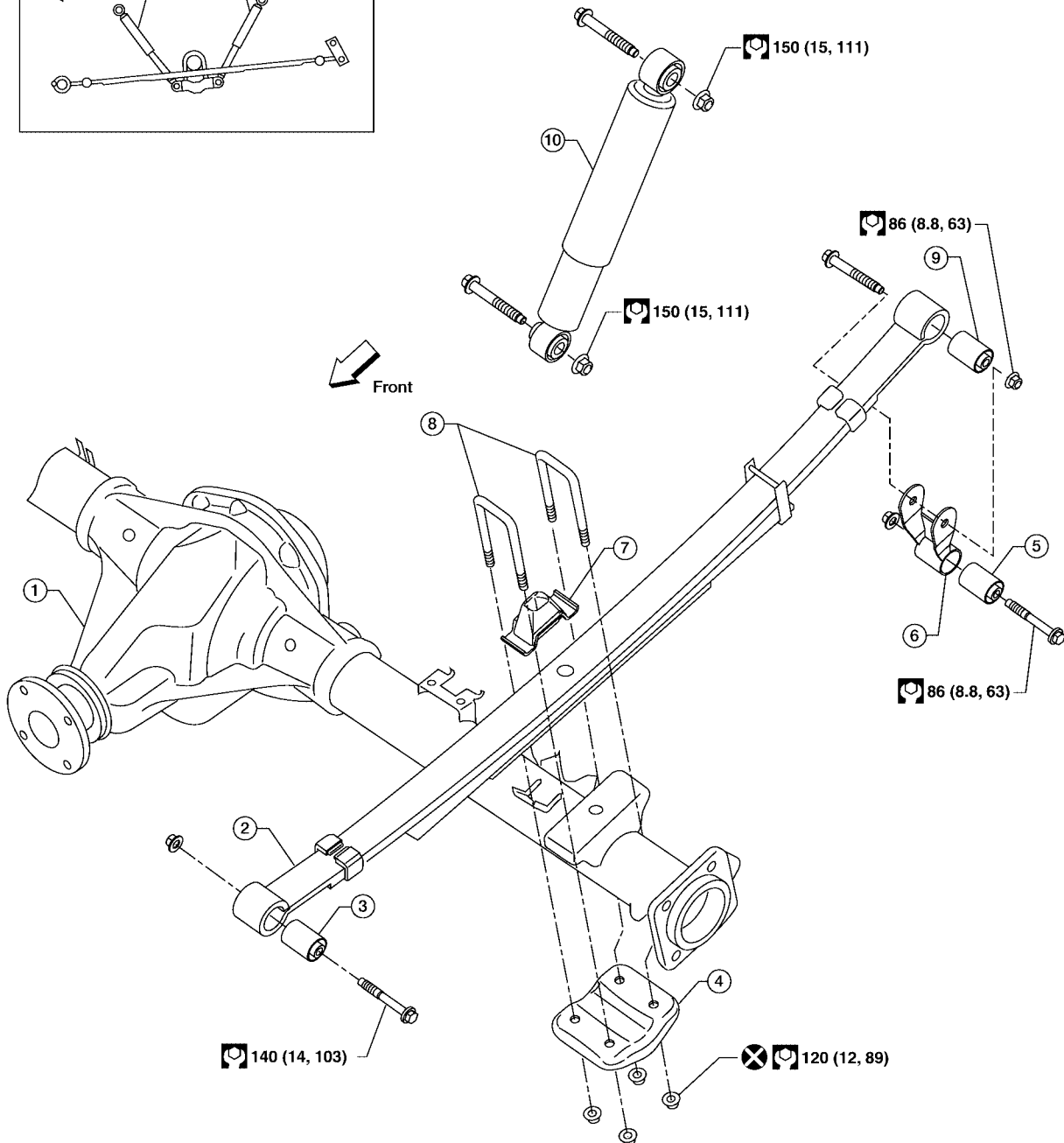
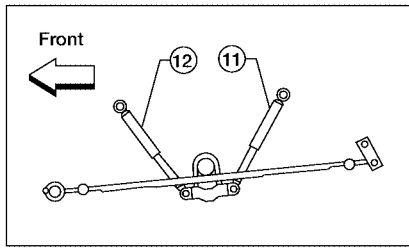

: N-m (kg-m, ft-lb)

: Always replace after every disassembly.

- | | | |
|---------------------|--------------------------------|---------------------------------|
| 1. Rear final drive | 2. Rear leaf spring | 3. Rear spring bushing (front) |
| 4. Rear spring pad | 5. Rear spring shackle bushing | 6. Rear spring shackle |
| 7. Bumper | 8. Rear spring clip U-bolts | 9. Rear spring bushing (rear) |
| 10. Shock absorber | 11. Shock absorber (left side) | 12. Shock absorber (right side) |

LEIA0102E

A
B
C
D
RSU
F
G
H
I
J
K
L
M

REAR SUSPENSION ASSEMBLY

CAUTION:

When installing the components with rubber bushings, the final tightening of the nuts and bolts must be done with the vehicle in an unladen condition (the fuel, engine coolant, and engine oil full; the spare tire, jack, hand tools and mats in their designated positions) with the tires on the ground.

On-Vehicle Inspection and Service

EES0002G

- Check the rear suspension parts for any excessive play, cracks, wear, and other damage.
- Shake each rear wheel to check for any excessive play as shown.
- Tighten all of the nuts and bolts to the specified torque. Refer to [RSU-5, "Components"](#).

CAUTION:

When installing the components with rubber bushings, the final tightening of the nuts and bolts must be done with the vehicle in an unladen condition (the fuel, engine coolant, and engine oil full; the spare tire, jack, hand tools and mats in their designated positions) with the tires on the ground.

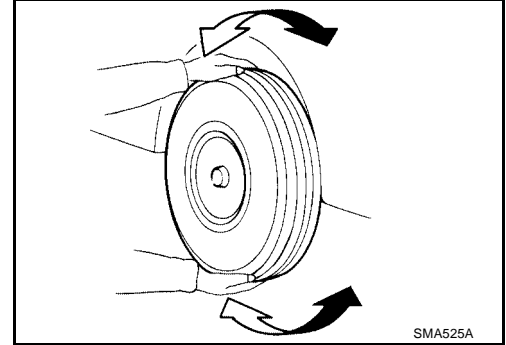

- Check the shock absorbers for oil leaks, deformation, and other damage.
- Check the shock absorber bushings for excessive wear and other damage.

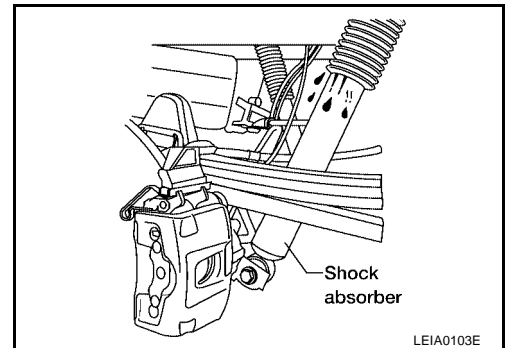

SHOCK ABSORBER

PFP:56210

SHOCK ABSORBER

Removal and Installation

REMOVAL

1. Support the rear final drive and suspension assembly using a suitable jack.
2. Remove the shock absorber upper and lower nuts and bolts using power tool.

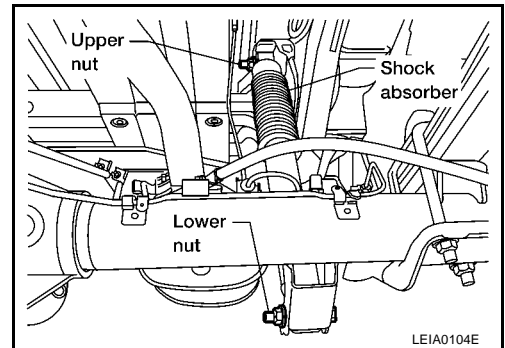

3. Remove the shock absorber.

INSPECTION AFTER REMOVAL

Inspect the shock absorber for any oil leaks, cracks, or deformations. Replace the shock absorber as necessary.

INSTALLATION

Installation is in the reverse order of removal.

Shock absorber upper and lower nuts : Refer to [RSU-5, "Components"](#) .

A
B
C
D
RSU
F
G
H
I
J
K
L
M

LEAF SPRING

PFP:55020

EES000ZJ

LEAF SPRING

Removal and Installation

SEC. 431

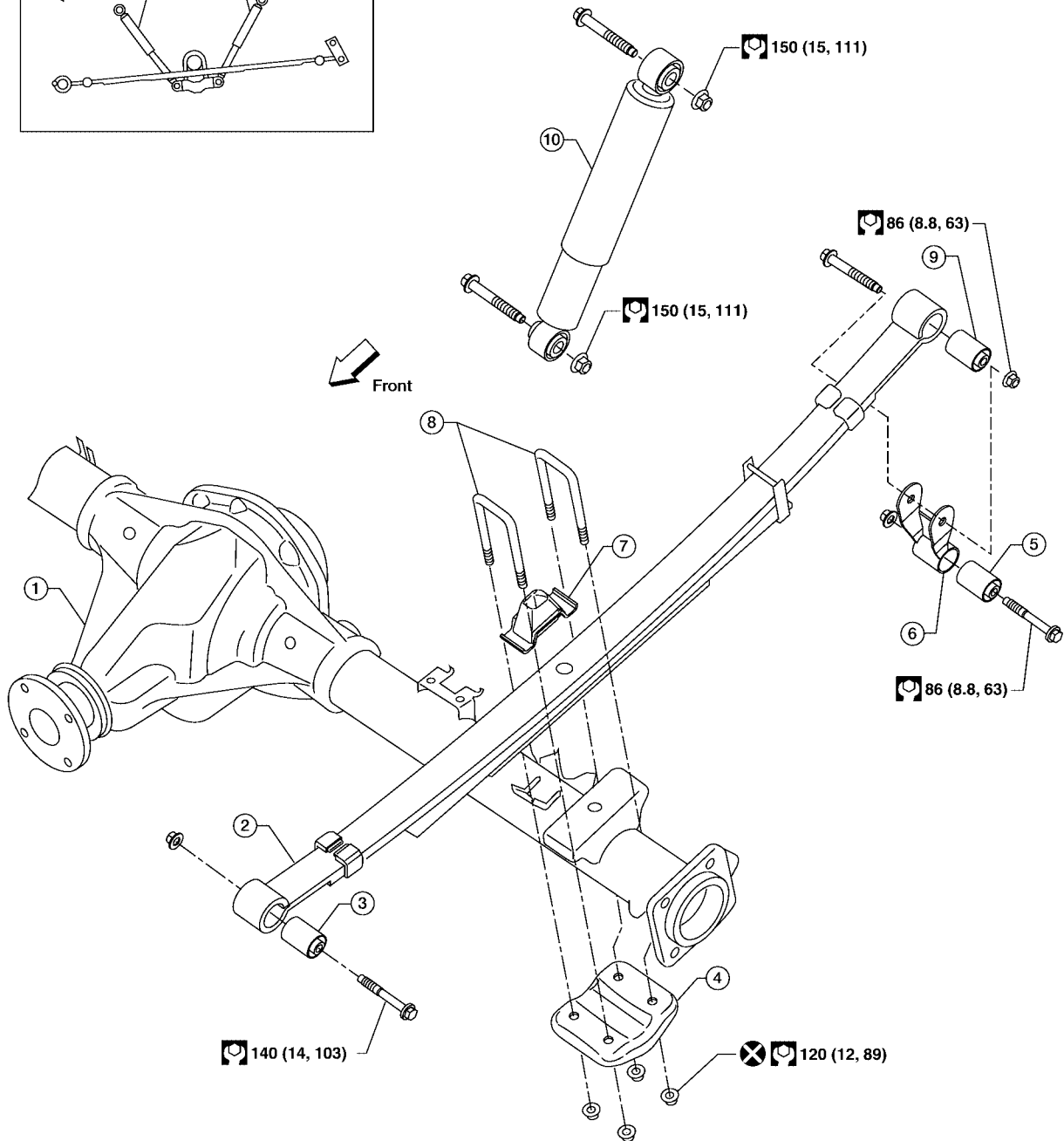
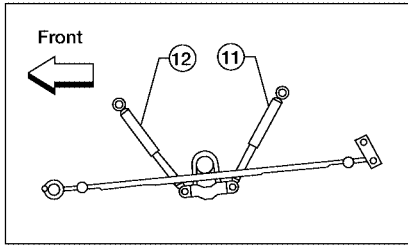

: N·m (kg·m, ft·lb)

: Always replace after every disassembly.

- | | | |
|---------------------|--------------------------------|---------------------------------|
| 1. Rear final drive | 2. Rear leaf spring | 3. Rear spring bushing (front) |
| 4. Rear spring pad | 5. Rear spring shackle bushing | 6. Rear spring shackle |
| 7. Bumper | 8. Rear spring clip U-bolts | 9. Rear spring bushing (rear) |
| 10. Shock absorber | 11. Shock absorber (left side) | 12. Shock absorber (right side) |

LEIA0102E

LEAF SPRING

CAUTION:

When installing the components with rubber bushings, the final tightening of the nuts and bolts must be done with the vehicle in an unladen condition (the fuel, engine coolant, and engine oil full; the spare tire, jack, hand tools and mats in their designated positions) with the tires on the ground.

REMOVAL

1. Support the rear final drive assembly with a suitable jack to relieve the tension from the leaf spring.
 - The axle weight should be supported, but there should be no compression in the spring.
2. Remove the shock absorber lower nut and bolt using power tool.

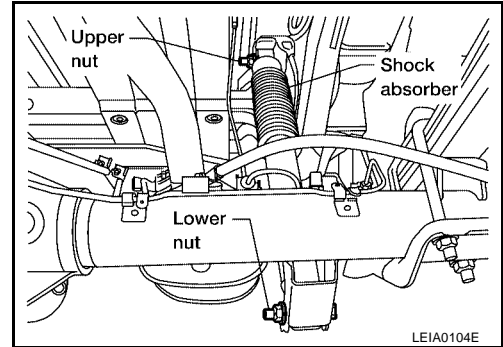

3. Remove the four rear spring clip U-bolt nuts using power tool, then remove the rear spring pad.

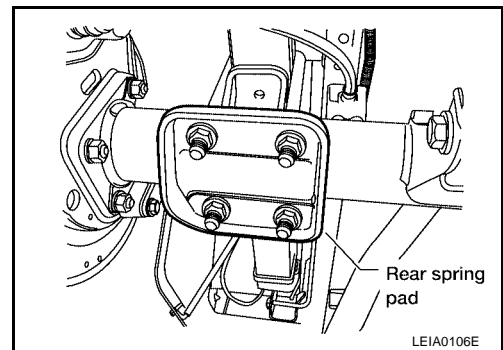

4. Remove the rear spring shackle lower nut and bolt using power tool.
 - If removing the LH rear leaf spring, remove the storage box if equipped, to access the rear spring shackle lower nut and bolt. Refer to [EI-50, "Removal and Installation"](#).

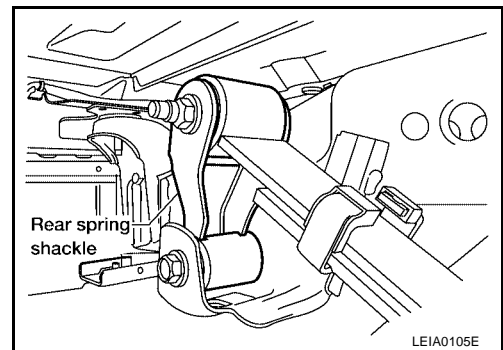

5. Remove the rear leaf spring front nut and bolt using power tool.
6. Remove the rear leaf spring.
7. Remove the rear spring shackle from the rear leaf spring as necessary, using power tool.

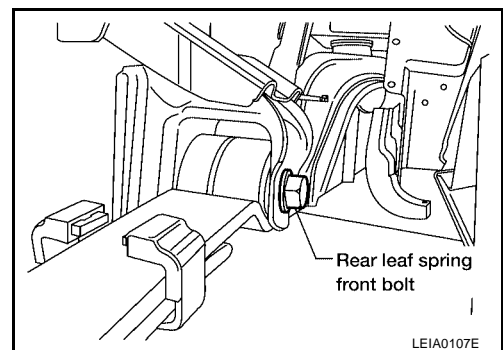

INSPECTION AFTER REMOVAL

- Check the rear leaf spring for any cracks or damage. Replace the rear leaf spring if necessary.

LEAF SPRING

- Check the rear spring shackle, rear spring clip U-bolts, bumper, and rear spring pad for excessive wear, cracks, straightness, and damage. Replace any components if necessary.
- Check all bushings for deformation and cracks. Replace any bushings if necessary.

INSTALLATION

1. Apply soapsuds to all of the rubber bushings.
2. Install the rear spring shackle and rear leaf spring front nut and bolt. Finger-tighten the nuts.
3. Install the rear spring clip U-bolts and bumper on top of the rear leaf spring.
4. Install the rear spring pad, and nuts under the axle case.
5. Tighten the rear spring clip U-bolt nuts diagonally and evenly.
 - Tighten the rear spring clip U-bolt nuts so the lengths of all the exposed rear spring clip U-bolt threads under spring pad are equal in length as shown.
6. Install the shock absorber, and finger-tighten the nuts.

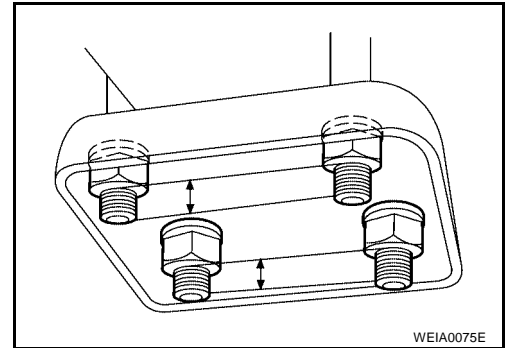

7. Remove the jack supporting the rear final drive assembly and bounce the rear of the vehicle to stabilize the suspension. (unladen)

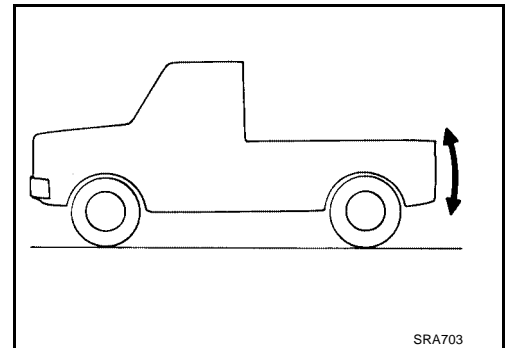

8. Tighten the rear spring shackle nuts, rear leaf spring front nut and shock absorber nuts to specification. When installing the components with rubber bushings, the final nut tightening must be carried out under unladen* conditions with the tires on level ground.
* (Fuel, radiator coolant and engine oil full. Spare tire, jack, hand tools and mats in designated positions.)

SERVICE DATA AND SPECIFICATIONS (SDS)

SERVICE DATA AND SPECIFICATIONS (SDS)

PF0:00030

General Specifications (Rear)

EES0002M

Suspension type	Rigid axle with semi-elliptic leaf spring
Shock absorber type	Double-acting hydraulic

Wheelarch Height (Unladen*1)

EES0012W

Unit: mm (in)

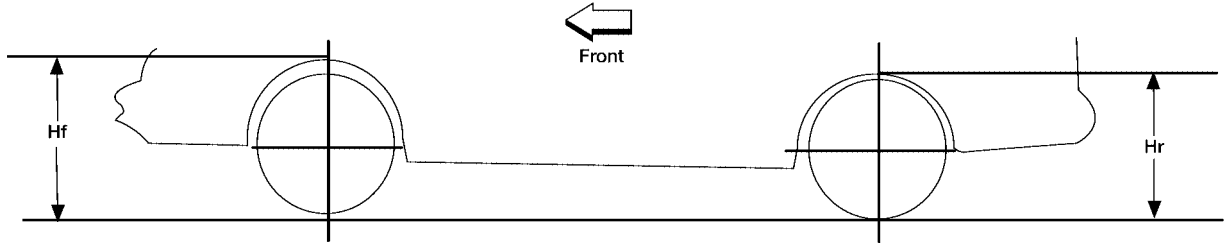

LEIA0085E

Drive type		4X2		4X4	
Body		King Cab	Crew Cab	King Cab	Crew Cab
Front wheelarch height (Hf)	265/70R18	913 (35.9)	916 (36.1)	952 (37.5) *2	955 (37.6) *2
	285/70R17	914 (36.0)	917 (36.1)	953 (37.5) *2	956 (37.6) *2
	245/75R17	904 (35.6)	907 (35.7)	941 (37.0)	944 (37.2)
Rear wheelarch height (Hr)	265/70R18	955 (37.6)	956 (37.6)	995 (39.2) *2	996 (39.2) *2
	285/70R17	956 (37.6)	957 (37.7)	996 (39.2) *2	997 (39.3) *2
	245/75R17	946 (37.2)	947 (37.3)	984 (38.7)	985 (38.8)

*1: Fuel, radiator coolant and engine oil full. Spare tire, jack, hand tools and mats in designated positions.

*2: Includes when equipped with tow package.

SERVICE DATA AND SPECIFICATIONS (SDS)
