

**SECTION MA**  
**MAINTENANCE**

A  
B  
C

**CONTENTS**

<p><b>PRECAUTIONS</b> ..... 2</p> <p>    Precautions for Supplemental Restraint System (SRS) "AIR BAG" and "SEAT BELT PRE-TENSIONER" ..... 2</p> <p><b>PREPARATION</b> ..... 3</p> <p>    Special Service Tools ..... 3</p> <p>    Commercial Service Tool ..... 3</p> <p><b>GENERAL MAINTENANCE</b> ..... 4</p> <p>    General Maintenance ..... 4</p> <p><b>PERIODIC MAINTENANCE</b> ..... 6</p> <p>    Introduction of Periodic Maintenance ..... 6</p> <p>    Schedule 1 ..... 6</p> <p>        EMISSION CONTROL SYSTEM MAINTENANCE ..... 6</p> <p>        CHASSIS AND BODY MAINTENANCE ..... 7</p> <p>    Schedule 2 ..... 8</p> <p>        EMISSION CONTROL SYSTEM MAINTENANCE ..... 8</p> <p>        CHASSIS AND BODY MAINTENANCE ..... 9</p> <p><b>RECOMMENDED FLUIDS AND LUBRICANTS</b> ..... 10</p> <p>    Fluids and Lubricants ..... 10</p> <p>    SAE Viscosity Number ..... 11</p> <p>        GASOLINE ENGINE OIL ..... 11</p> <p>        ANTI-FREEZE COOLANT MIXTURE RATIO ..... 11</p> <p><b>ENGINE MAINTENANCE</b> ..... 12</p> <p>    Checking Drive Belts ..... 12</p> <p>        DRIVE BELT TENSION ..... 12</p> <p>    Changing Engine Coolant ..... 12</p> <p>        DRAINING ENGINE COOLANT ..... 12</p> <p>        REFILLING ENGINE COOLANT ..... 13</p> <p>        FLUSHING COOLING SYSTEM ..... 14</p> <p>    Checking Fuel Lines ..... 15</p> <p>    Changing Fuel Filter ..... 15</p> <p>    Changing Engine Air Cleaner Filter ..... 15</p> <p>        VISCOUS PAPER TYPE ..... 15</p> <p>    Changing Engine Oil ..... 16</p> <p>    Changing Oil Filter ..... 16</p>	<p>    Changing Spark Plugs ..... 17</p> <p>        REMOVAL ..... 17</p> <p>        INSPECTION AFTER REMOVAL ..... 18</p> <p>        INSTALLATION ..... 19</p> <p>    Checking EVAP Vapor Lines ..... 19</p> <p><b>CHASSIS AND BODY MAINTENANCE</b> ..... 20</p> <p>    Changing In-cabin Microfilter ..... 20</p> <p>    Checking Exhaust System ..... 21</p> <p>    Checking A/T Fluid ..... 21</p> <p>    Changing A/T Fluid ..... 23</p> <p>    Checking Transfer Fluid ..... 24</p> <p>    Changing Transfer Fluid ..... 24</p> <p>    Checking Propeller Shaft ..... 24</p> <p>    Checking Final Drive Oil ..... 24</p> <p>    Changing Final Drive Oil ..... 25</p> <p>    Balancing Wheels ..... 25</p> <p>    Tire Rotation ..... 26</p> <p>    Checking Brake Fluid Level and Leaks ..... 26</p> <p>    Checking Brake Lines and Cables ..... 26</p> <p>    Checking Disc Brake ..... 27</p> <p>        ROTOR ..... 27</p> <p>        CALIPER ..... 27</p> <p>        PAD ..... 27</p> <p>    Checking Steering Gear and Linkage ..... 27</p> <p>        STEERING GEAR ..... 27</p> <p>        STEERING LINKAGE ..... 27</p> <p>    Checking Power Steering Fluid and Lines ..... 28</p> <p>        CHECKING FLUID LEVEL ..... 28</p> <p>        CHECKING LINES ..... 28</p> <p>    Checking Axle and Suspension Parts ..... 28</p> <p>        FRONT AND REAR AXLE AND SUSPENSION PARTS ..... 28</p> <p>        DRIVE SHAFT ..... 28</p> <p>    Lubricating Locks, Hinges and Hood Latches ..... 29</p> <p>    Checking Seat Belts, Buckles, Retractors, Anchors and Adjusters ..... 30</p>
--	--

D  
E

F  
G

H  
I

J  
K

MA

M

# PRECAUTIONS

---

## PRECAUTIONS

PFP:00001

### Precautions for Supplemental Restraint System (SRS) “AIR BAG” and “SEAT BELT PRE-TENSIONER”

ELS000YP

The Supplemental Restraint System such as “AIR BAG” and “SEAT BELT PRE-TENSIONER”, used along with a front seat belt, helps to reduce the risk or severity of injury to the driver and front passenger for certain types of collision. This system includes seat belt switch inputs and dual stage front air bag modules. The SRS system uses the seat belt switches to determine the front air bag deployment, and may only deploy one front air bag, depending on the severity of a collision and whether the front occupants are belted or unbelted. Information necessary to service the system safely is included in the SRS and SB section of this Service Manual.

#### **WARNING:**

- To avoid rendering the SRS inoperative, which could increase the risk of personal injury or death in the event of a collision which would result in air bag inflation, all maintenance must be performed by an authorized NISSAN/INFINITI dealer.
- Improper maintenance, including incorrect removal and installation of the SRS, can lead to personal injury caused by unintentional activation of the system. For removal of Spiral Cable and Air Bag Module, see the SRS section.
- Do not use electrical test equipment on any circuit related to the SRS unless instructed to in this Service Manual. SRS wiring harnesses can be identified by yellow and/or orange harnesses or harness connectors.

# PREPARATION

## PREPARATION

PF0:00002

### Special Service Tools

ELS000YQ

The actual shapes of Kent-Moore tools may differ from those of special service tools illustrated here.

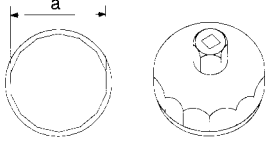
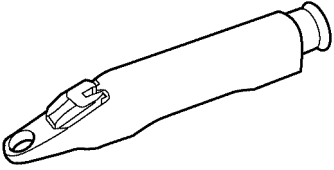
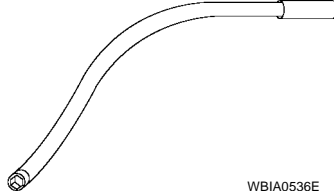
Tool number (Kent-Moore No.) Tool name	Description
KV10115801 (J-38956) Oil filter cap wrench <div style="text-align: center;">  <p>NT375</p> </div>	Removing and installing oil filter <b>a: 64.3 mm (2.531 in)</b>
— (J-23688) Engine coolant refractometer <div style="text-align: center;">  <p>WBIA0539E</p> </div>	Checking concentration of ethylene glycol in engine coolant
— (J-46535) Drive belt tension releaser <div style="text-align: center;">  <p>WBIA0536E</p> </div>	Releasing drive belt tension

## Commercial Service Tool

ELS000YR

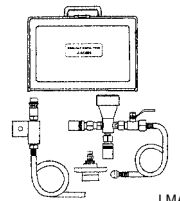
(Kent-Moore No.) Tool name	Description
(J-45695) Coolant refill tool <div style="text-align: center;">  <p>LMA053</p> </div>	Filling cooling system

A  
B  
C  
D  
E  
F  
G  
H  
I  
J  
K  
MA  
M

# GENERAL MAINTENANCE

## GENERAL MAINTENANCE

PF0:0000

### General Maintenance

ELS000YS

General maintenance includes those items which should be checked during the normal day-to-day operation of the vehicle. They are essential if the vehicle is to continue operating properly. The owner can perform these checks and inspections or have their NISSAN dealers perform them.

#### OUTSIDE THE VEHICLE

The maintenance items listed here should be performed from time to time, unless otherwise specified.

Item		Reference page
<b>Tires</b>	Check the pressure with a gauge at least once a month and always prior to a long distance trip. Adjust to the specified pressure if necessary. Check carefully for damage, cuts or excessive wear.	—
<b>Wheel lug nuts</b>	When checking the tires, make sure no nuts are missing, and check for any loose nuts. Tighten if necessary.	<a href="#">WT-6, "Rotation"</a>
<b>Windshield</b>	Clean the windshield on a regular basis. Check the windshield at least every six months for cracks or other damage. Repair as necessary.	
<b>Tire rotation</b>	Tires should be rotated every 12,000 km (7,500 miles).	<a href="#">WT-6, "Rotation"</a>
<b>Wheel alignment and balance</b>	If the vehicle pulls to either side while driving on a straight and level road, or if you detect uneven or abnormal tire wear, there may be a need for wheel alignment. If the steering wheel or seat vibrates at normal highway speeds, wheel balancing may be needed.	<a href="#">WT-5, "Balancing Wheels"</a> , <a href="#">FSU-6, "Front Wheel Alignment"</a>
<b>Windshield wiper blades</b>	Check for cracks or wear if they do not wipe properly.	—
<b>Doors and engine hood</b>	Check that all doors and the engine hood operate smoothly as well as the back hatch. Also make sure that all latches lock securely. Lubricate if necessary. Make sure that the secondary latch keeps the hood from opening when the primary latch is released. When driving in areas using road salt or other corrosive materials, check lubrication frequently.	<a href="#">MA-29, "Lubricating Locks, Hinges and Hood Latches"</a>
<b>Lamps</b>	Make sure that the head lamps, stop lamps, tail lamps, turn signal lamps, and other lamps are all operating properly and installed securely. Also check head lamp aim. Clean the head lamps on a regular basis.	<a href="#">LT-31, "Aiming Adjustment"</a> for US, <a href="#">LT-48, "Aiming Adjustment"</a> for Canada

#### INSIDE THE VEHICLE

The maintenance items listed here should be checked on a regular basis, such as when performing periodic maintenance, cleaning the vehicle, etc.

Item		Reference page
<b>Warning lamps and buzzers/chimes</b>	Make sure that all warning lamps and buzzers/chimes are operating properly.	<a href="#">DI-25, "Electrical Components Inspection"</a>
<b>Windshield wiper and washer</b>	Check that the wipers and washer operate properly and that the wipers do not streak.	—
<b>Windshield defroster</b>	Check that the air comes out of the defroster outlets properly and in sufficient quantity when operating the heater or air conditioner.	—
<b>Steering wheel</b>	Check that it has the specified play. Be sure to check for changes in the steering condition, such as excessive play, hard steering or strange noises.	<a href="#">PS-7, "CHECKING STEERING WHEEL PLAY"</a>
<b>Seats</b>	Check seat position controls such as seat adjusters, seat back recliner, etc. to make sure they operate smoothly and that all latches lock securely in every position. Check that the head restraints move up and down smoothly and that the locks (if equipped) hold securely in all latched positions. Check that the latches lock securely for folding-down rear seat backs.	—
<b>Seat belts</b>	Check that all parts of the seat belt system (e.g. buckles, anchors, adjusters and retractors) operate properly and smoothly and are installed securely. Check the belt webbing for cuts, fraying, wear or damage.	<a href="#">SB-10, "Seat Belt Inspection"</a> , <a href="#">MA-30, "Checking Seat Belts, Buckles, Retractors, Anchors and Adjusters"</a>
<b>Accelerator pedal</b>	Check the pedal for smooth operation. Keep the floor mats away from the pedal.	—

# GENERAL MAINTENANCE

Item		Reference page	
<b>Brakes</b>	Check that the brake does not pull the vehicle to one side when applied.	—	A
<b>Brake pedal and booster</b>	Check the pedal for smooth operation and make sure it has the proper distance under it when depressed fully. Check the brake booster function. Keep the floor mats away from the pedal.	<a href="#">BR-6, "Inspection and Adjustment"</a> , <a href="#">BR-18, "On-Vehicle Service"</a>	B
<b>Parking brake</b>	Check that the parking brake control has the proper travel and make sure that the vehicle is held securely on a fairly steep hill when only the parking brake is applied.	<a href="#">PB-3, "On-Vehicle Service"</a>	C
<b>Automatic transmission "Park" mechanism</b>	On a fairly steep hill check that the vehicle is held securely with the selector lever in the P position without applying the brakes.	—	D

## UNDER THE HOOD AND VEHICLE

The maintenance items listed here should be checked periodically (e.g. each time you check the engine oil or refuel).

Item		Reference page	
<b>Windshield washer fluid</b>	Check that there is adequate fluid in the tank.	—	E
<b>Engine coolant level</b>	Check the coolant level when the engine is cold.	<a href="#">MA-12</a>	F
<b>Radiator and hoses</b>	Check the front of the radiator and clean off any dirt, insects, leaves, etc., that may have accumulated. Make sure the hoses have no cracks, deformation, deterioration or loose connections.	—	G
<b>Brake fluid level</b>	Make sure that the brake fluid level is between the "MAX" and "MIN" lines on the reservoirs	<a href="#">MA-26</a>	
<b>Battery</b>	Check the fluid level in each cell. It should be between the "MAX" and "MIN" lines. Vehicles operated in high temperatures or under severe conditions require frequent checks of the battery fluid level.	—	H
<b>Engine drive belt</b>	Make sure that no belt is frayed, worn, cracked or oily.	<a href="#">MA-12</a>	I
<b>Engine oil level</b>	Check the level on the dipstick after parking the vehicle on a level spot and turning off the engine.	<a href="#">MA-16</a>	
<b>Power steering fluid level and lines</b>	Check the level on the reservoir with the engine off. Check the lines for improper attachment, leaks, cracks, etc.	<a href="#">MA-28</a>	J
<b>Automatic transmission fluid level</b>	Check the level on the dipstick after putting the selector lever in "P" with the engine idling.	<a href="#">MA-21</a>	K
<b>Exhaust system</b>	Make sure there are no loose supports, cracks or holes. If the sound of the exhaust seems unusual or there is a smell of exhaust fumes, immediately locate the trouble and correct it.	<a href="#">MA-21</a>	MA
<b>Underbody</b>	The underbody is frequently exposed to corrosive substances such as those used on icy roads or to control dust. It is very important to remove these substances, otherwise rust will form on the floor pan, frame, fuel lines and around the exhaust system. At the end of winter, the underbody should be thoroughly flushed with plain water, being careful to clean those areas where mud and dirt can easily accumulate.	—	M
<b>Fluid leaks</b>	Check under the vehicle for fuel, oil, water or other fluid leaks after the vehicle has been parked for a while. Water dripping from the air conditioner after use is normal. If you should notice any leaks or gasoline fumes are evident, check for the cause and correct it immediately.	—	

# PERIODIC MAINTENANCE

## PERIODIC MAINTENANCE

PFP:00026

### Introduction of Periodic Maintenance

ELS000YT

Two different maintenance schedules are provided, and should be used, depending upon the conditions in which the vehicle is mainly operated. **After 60,000 miles (96,000 km) or 48 months, continue the periodic maintenance at the same mileage or time intervals, whichever comes first.**

Schedule 1	<p>Follow Periodic Maintenance Schedule 1 if your driving habits frequently includes one or more of the following driving conditions:</p> <ul style="list-style-type: none"> <li>● Repeated short trips of less than 5 miles (8 km).</li> <li>● Repeated short trips of less than 10 miles (16 km) with outside temperatures remaining below freezing.</li> <li>● Operating in hot weather in stop-and-go “rush hour” traffic.</li> <li>● Extensive idling and/or low speed driving for long distances, such as police, taxi or door-to-door delivery use.</li> <li>● Driving in dusty conditions.</li> <li>● Driving on rough, muddy, or salt spread roads.</li> <li>● Towing a trailer or a car-top carrier.</li> </ul>	Emission Control System Maintenance	<a href="#">MA-6</a>
		Chassis and Body Maintenance	<a href="#">MA-7</a>
Schedule 2	<p>Follow Periodic Maintenance Schedule 2 if none of the driving conditions shown in Schedule 1 apply to the driving habits.</p>	Emission Control System Maintenance	<a href="#">MA-8</a>
		Chassis and Body Maintenance	<a href="#">MA-9</a>

### Maintenance for off-road driving (4x4 only)

After driving the vehicle off-road through sand, mud, or water; more frequent maintenance may be required for the following items:

- ▲ Brake pads and rotors
- ▲ Brake lines and hoses
- ▲ Rear final drive oil, transmission fluid, and transfer fluid
- ▲ Steering linkage
- ▲ Drive shafts
- ▲ Engine air cleaner filter
- ▲ In-cabin microfilters

### Schedule 1

ELS000YU

#### EMISSION CONTROL SYSTEM MAINTENANCE

Abbreviations: R = Replace. I = Inspect. Correct or replace if necessary. [ ]: At the mileage intervals only

MAINTENANCE OPERATION		MAINTENANCE INTERVAL								Reference Section - Page or - Content Title
Perform at number of miles, kilometers or months, whichever comes first.	Miles x 1,000 (km x 1,000) Months	3.75 (6)	7.50 (12)	11.25 (18)	15 (24)	18.75 (30)	22.5 (36)	26.25 (42)	30 (48)	
Drive belts	NOTE (1)									<a href="#">MA-12</a>
Air cleaner filter	NOTE (2)								[R]	<a href="#">EM-14</a>
EVAP vapor lines									I*	<a href="#">MA-19</a>
Fuel lines									I*	<a href="#">MA-15</a>
Fuel filter	NOTE (3)									<a href="#">MA-15</a>
Engine coolant	NOTE (4)									<a href="#">MA-12</a>
Engine oil		R	R	R	R	R	R	R	R	<a href="#">MA-16</a>
Engine oil filter		R	R	R	R	R	R	R	R	<a href="#">MA-16</a>
Spark plugs (PLATINUM-TIPPED type)		Replace every 105,000 miles (169,000 km).								<a href="#">MA-17</a>
Intake and exhaust valve clearance*	NOTE (5)									<a href="#">EM-52</a>

# PERIODIC MAINTENANCE

MAINTENANCE OPERATION		MAINTENANCE INTERVAL								Reference Section - Page or - Content Title
Perform at number of miles, kilometers or months, whichever comes first.	Miles x 1,000 (km x 1,000) Months	33.75 (54) 27	37.5 (60) 30	41.25 (66) 33	45 (72) 36	48.75 (78) 39	52.5 (84) 42	56.25 (90) 45	60 (96) 48	
Drive belts	NOTE (1)								I*	<a href="#">MA-12</a>
Air cleaner filter	NOTE (2)								[R]	<a href="#">EM-14</a>
EVAP vapor lines									I*	<a href="#">MA-19</a>
Fuel lines									I*	<a href="#">MA-15</a>
Fuel filter	NOTE (3)									<a href="#">MA-15</a>
Engine coolant	NOTE (4)								R*	<a href="#">MA-12</a>
Engine oil		R	R	R	R	R	R	R	R	<a href="#">MA-16</a>
Engine oil filter		R	R	R	R	R	R	R	R	<a href="#">MA-16</a>
Spark plugs (PLATINUM-TIPPED type)		Replace every 105,000 miles (169,000 km).								<a href="#">MA-17</a>
Intake and exhaust valve clearance*	NOTE (5)									<a href="#">EM-52</a>

**NOTE:**

- (1) After 60,000 miles (96,000 km) or 48 months, inspect every 15,000 miles (24,000 km) or 12 months. Replace the drive belts if found damaged.
  - (2) If operating mainly in dusty conditions, more frequent maintenance may be required.
  - (3) Maintenance-free item. For service procedures, go to the FL section.
  - (4) After 60,000 miles (96,000 km) or 48 months, replace every 30,000 miles (48,000 km) or 24 months.
  - (5) If valve noise increases, inspect valve clearance.
- \* Maintenance items and intervals with “\*” are recommended by NISSAN for reliable vehicle operation. The owner need not perform such maintenance in order to maintain the emission warranty or manufacturer recall liability. Other maintenance items and intervals are required.

## CHASSIS AND BODY MAINTENANCE

Abbreviations: R = Replace. I = Inspect. Correct or replace if necessary. L = Lubricate. [ ]: At the mileage intervals only.

MAINTENANCE OPERATION		MAINTENANCE INTERVAL								Reference Section - Page or - Content Title
Perform at number of miles, kilometers or months, whichever comes first.	Miles x 1,000 (km x 1,000) Months	3.75 (6) 3	7.5 (12) 6	11.25 (18) 9	15 (24) 12	18.75 (30) 15	22.5 (36) 18	26.25 (42) 21	30 (48) 24	
Brake lines and cables					I				I	<a href="#">MA-26</a>
Brake pads and rotors			I		I		I		I	<a href="#">MA-27</a>
Automatic transmission fluid	NOTE (1)				I				I	<a href="#">MA-21</a>
Transfer fluid and front final drive oil	NOTE (1)				I				I	<a href="#">MA-24, MA-24</a>
Rear final drive oil	NOTE (2)				I				I	<a href="#">MA-24, MA-24</a>
Steering gear, linkage, axle, and suspension parts			I		I		I		I	<a href="#">MA-27, MA-28</a>
Tire Rotation	NOTE (3)									<a href="#">MA-26</a>
Drive shaft boots and propeller shaft (4x4)			I		I		I		I	<a href="#">MA-24</a>
Exhaust system			I		I		I		I	<a href="#">MA-21</a>
In-cabin microfilter					R				R	<a href="#">MA-20</a>

# PERIODIC MAINTENANCE

MAINTENANCE OPERATION		MAINTENANCE INTERVAL								Reference Section - Page or - Content Title
	Miles x 1,000 (km x 1,000) Months	33.75 (54) 27	37.5 (60) 30	41.25 (66) 33	45 (72) 36	48.75 (78) 39	52.5 (84) 42	56.25 (90) 45	60 (96) 48	
Perform at number of miles, kilometers or months, whichever comes first.										
Brake lines and cables					I				I	<a href="#">MA-26</a>
Brake pads and rotors			I		I		I		I	<a href="#">MA-27</a>
Automatic transmission fluid	NOTE (1)				I				I	<a href="#">MA-21</a>
Transfer fluid and front final drive oil	NOTE (1)				I				I	<a href="#">MA-24</a> , <a href="#">MA-24</a>
Rear final drive oil	NOTE (2)				I				I	<a href="#">MA-24</a> , <a href="#">MA-24</a>
Steering gear, linkage, axle, and suspension parts			I		I		I		I	<a href="#">MA-27</a> , <a href="#">MA-28</a>
Tire Rotation	NOTE (3)									<a href="#">MA-26</a>
Drive shaft boots and propeller shaft (4x4)			I		I		I		I	<a href="#">MA-24</a>
Exhaust system			I		I		I		I	<a href="#">MA-21</a>
In-cabin microfilter					R				R	<a href="#">MA-20</a>

**NOTE:**

- (1) If towing a trailer, or a car-top carrier, or driving on rough or muddy roads, change (not just inspect) oil at every 30,000 miles (48,000 km) or 24 months.
- (2) If towing a trailer, or a car-top carrier, or driving on rough or muddy roads, change (not just inspect) oil at every 3,000 miles (5,000 km) or 3 months.
- (3) Refer to "Tire rotation" under the "General maintenance" heading earlier in this section.

## Schedule 2 EMISSION CONTROL SYSTEM MAINTENANCE

ELS000YV

Abbreviations: R = Replace. I = Inspect. Correct or replace if necessary. [ ]: At the mileage intervals only

MAINTENANCE OPERATION		MAINTENANCE INTERVAL								Reference Section - Page or - Content Title
	Miles x 1,000 (km x 1,000) Months	7.5 (12) 6	15 (24) 12	22.5 (36) 18	30 (48) 24	37.5 (60) 30	45 (72) 36	52.5 (84) 42	60 (96) 48	
Perform at number of miles, kilometers or months, whichever comes first.										
Drive belts	NOTE (1)								I*	<a href="#">MA-12</a>
Air cleaner filter					[R]				[R]	<a href="#">EM-14</a>
EVAP vapor lines					I*				I*	<a href="#">MA-19</a>
Fuel lines					I*				I*	<a href="#">MA-15</a>
Fuel filter	NOTE (2)									<a href="#">MA-15</a>
Engine coolant	NOTE (3)								R*	<a href="#">MA-12</a>
Engine oil		R	R	R	R	R	R	R	R	<a href="#">MA-16</a>
Engine oil filter		R	R	R	R	R	R	R	R	<a href="#">MA-16</a>
Spark plugs (PLATINUM-TIPPED type)		Replace every 105,000 miles (169,000 km).								<a href="#">MA-17</a>
Intake and exhaust valve clearance*	NOTE (4)									<a href="#">EM-52</a>

**NOTE:**

- (1) After 60,000 miles (96,000 km) or 48 months, inspect every 15,000 miles (24,000 km) or 12 months. Replace the drive belts if found damaged.
- (2) Maintenance-free item. For service procedures, go to FL section.
- (3) After 60,000 miles (96,000 km) or 48 months, replace every 30,000 miles (48,000 km) or 24 months.
- (4) If valve noise increases, inspect valve clearance.



# PERIODIC MAINTENANCE

\* Maintenance items and intervals with “\*” are recommended by NISSAN for reliable vehicle operation. The owner need not perform such maintenance in order to maintain the emission warranty or manufacturer recall liability. Other maintenance items and intervals are required.

## CHASSIS AND BODY MAINTENANCE

Abbreviations: R = Replace. I = Inspect. Correct or replace if necessary. L = Lubricate. [ ]: At the mileage interval only.

MAINTENANCE OPERATION		MAINTENANCE INTERVAL								Reference Section - Page or - Content Title
Perform at number of miles, kilometers or months, whichever comes first.	Miles x 1,000 (km x 1,000) Months	7.5 (12) 6	15 (24) 12	22.5 (36) 18	30 (48) 24	37.5 (60) 30	45 (72) 36	52.5 (84) 42	60 (96) 48	
Brake lines and cables			I		I		I		I	<a href="#">MA-26</a>
Brake pads and rotors			I		I		I		I	<a href="#">MA-27</a>
Automatic transmission fluid			I		I		I		I	<a href="#">MA-21</a>
Transfer fluid and front final drive oil			I		I		I		I	<a href="#">MA-24,</a> <a href="#">MA-24</a>
Rear final drive oil			I		I		I		I	<a href="#">MA-24,</a> <a href="#">MA-24</a>
Steering gear, linkage, axle, and suspension parts.					I				I	<a href="#">MA-27,</a> <a href="#">MA-28</a>
Tire rotation	NOTE (1)									<a href="#">MA-26</a>
Drive shaft boots and propeller shaft (4x4)			I		I		I		I	<a href="#">MA-24</a>
Exhaust system					I				I	<a href="#">MA-21</a>
In-cabin microfilter			R		R		R		R	<a href="#">MA-20</a>

### NOTE:

- (1) Refer to “Tire rotation” under the “General maintenance” heading earlier in this section.

# RECOMMENDED FLUIDS AND LUBRICANTS

## RECOMMENDED FLUIDS AND LUBRICANTS

PFP:00000

### Fluids and Lubricants

ELS000YW

Description		Capacity (Approximate)			Recommended Fluids/Lubricants
		Metric	US measure	Imp measure	
Fuel		105.8 ℓ	28 gal	23 1/4 gal	Unleaded gasoline with an octane rating of at least 87 AKI (RON 91)
Engine oil Drain and refill	With oil filter change	6.2 ℓ	6 1/2 qt	5 1/2 qt	<ul style="list-style-type: none"> <li>● API Certification Mark*1</li> <li>● API grade SL, Energy Conserving*1</li> <li>● ILSAC grade GF-III*1</li> </ul>
	Without oil filter change	5.9 ℓ	6 1/4 qt	5 1/4 qt	
Dry engine (engine overhaul)		7.6 ℓ	8 qt	6 3/4 qt	
Cooling system with reservoir ("MAX" level)		12.2 ℓ	3 1/4 gal	2 5/8 gal	Genuine NISSAN Long Life Anti-freeze coolant or equivalent
Automatic transmission fluid (ATF)		10.6 ℓ	11 1/4 qt	9 3/8 qt	Genuine NISSAN Matic J ATF*2
Rear final drive oil		2.01 ℓ	4 1/4 pt	3 1/2 pt	API GL-5 Viscosity SAE 80W-90 *6
Transfer fluid		2.0 ℓ	2 1/8 qt	1 3/4 qt	Genuine NISSAN Matic D ATF (Continental U.S and Alaska) or Canada NISSAN Automatic Transmission Fluid *7
Front final drive oil		1.6 ℓ	3 3/8 pt	2 7/8 pt	API GL-5 Viscosity SAE 80W-90 *6
Power steering fluid (PSF)		1.0 ℓ	2 1/8 pt	1 3/4 pt	Genuine NISSAN PSF or equivalent*3
Brake fluid		—	—	—	Genuine NISSAN Super Heavy Duty Brake Fluid or equivalent, DOT 3 (US FMVSS No. 116) *4
Multi-purpose grease		—	—	—	NLGI No. 2 (lithium soap base)
Windshield washer fluid		4.5 ℓ	1 1/4 gal	1 gal	Genuine NISSAN Windshield Washer Concentrate Cleaner & Anti-freeze or equivalent
Air conditioning system refrigerant		700 ± 50 g	24.69 ± 1.76 oz	24.69 ± 1.76 oz	HFC-134a (R-134a)*5
Air conditioning system lubricants		200 m ℓ	6.8 fl oz	7.0 fl oz	NISSAN Luminous Oil Type S (DH-PS) (part no. KLH00-PAGS0) or equivalent*5

\*1: For further details, see "SAE Viscosity Number".

\*2: Using automatic transmission fluid other than Genuine NISSAN Matic J ATF will cause deterioration in driveability and automatic transmission durability, and may damage the automatic transmission, which is not covered by the NISSAN new vehicle limited warranty.

\*3: For Canada, NISSAN Automatic Transmission Fluid (ATF), DEXRON™ III or MERCON™ or equivalent ATF may also be used.

\*4: Available in mainland U.S.A. through your NISSAN dealer.

\*5: For further details, see "Air conditioner specification label".

\*6: For hot climates, viscosity SAE 90 is suitable for ambient temperatures above 0° C (32° F).

\*7: DEXRON™ III, MERCON™ or equivalent may also be used. Outside the continental United States and Alaska contact a NISSAN dealership for more information regarding suitable fluids, including recommended brand(s) of DEXRON™ III or MERCON™ Automatic Transmission Fluid.

# RECOMMENDED FLUIDS AND LUBRICANTS

ELS000YX

## SAE Viscosity Number GASOLINE ENGINE OIL

- SAE 5W-30 viscosity oil is preferred for all temperatures. SAE 10W-30 and 10W-40 viscosity oil may be used if the ambient temperature is above -18°C (0°F).
- Use of 5W-30 viscosity oil will increase fuel economy.

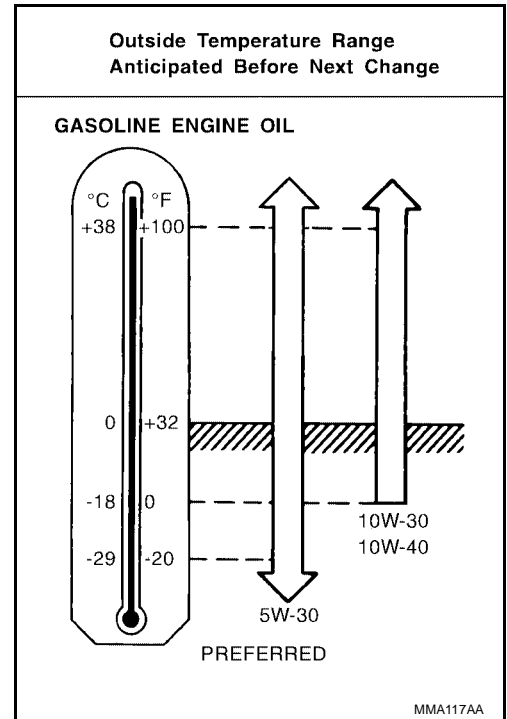

## ANTI-FREEZE COOLANT MIXTURE RATIO

The engine cooling system is filled at the factory with a high-quality, long life, year-round, anti-freeze coolant solution. The anti-freeze solution contains rust and corrosion inhibitors. Therefore, additional cooling system additives are not necessary.

For outside temperatures down to:		Anti-freeze coolant mixture ratio	
°C	°F	Genuine NISSAN Long Life Antifreeze coolant	Demineralized water or distilled water
-35°	-30°	50 %	50 %

### CAUTION:

- When adding or replacing coolant, be sure to use only Genuine NISSAN Long Life Anti-freeze coolant or equivalent with the proper mixture ratio of 50% anti-freeze and 50% demineralized water or distilled water.
- Other types of coolant solutions may damage your cooling system.

### Checking Drive Belts

ELS000YY

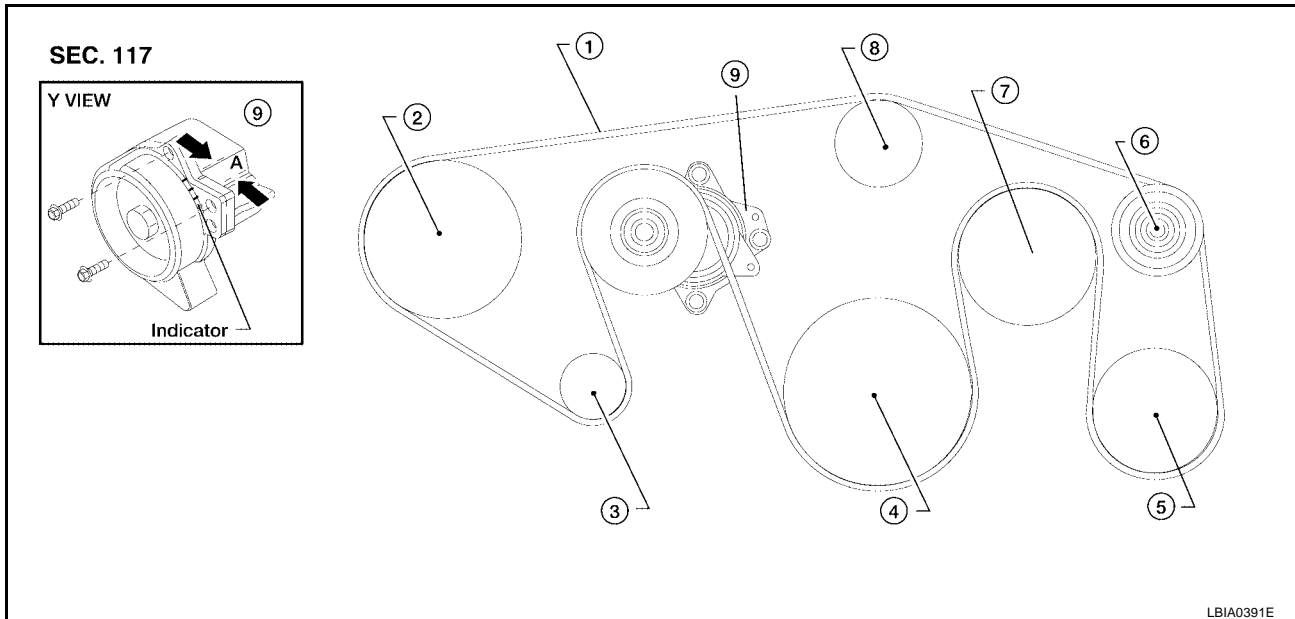

- |                       |                               |                         |
|-----------------------|-------------------------------|-------------------------|
| 1. Drive Belt         | 2. Power Steering Pump Pulley | 3. Generator pulley     |
| 4. Crankshaft Pulley  | 5. A/C Compressor             | 6. Idler Pulley         |
| 7. Cooling Fan Pulley | 8. Water Pump Pulley          | 9. Drive Belt Tensioner |

LBIA0391E

#### **WARNING:**

**Be sure to perform when the engine is stopped.**

1. Remove air duct and resonator assembly (inlet) when inspecting drive belt.
2. Make sure that indicator (single line notch) of each auto tensioner is within the allowable working range "A" (between three line notches) as shown.

#### **NOTE:**

- Check the auto tensioner indication when the engine is cold.
  - When the new drive belt is installed, the range should be as shown.
  - The indicator notch is located on the moving side of the auto tensioner.
3. Visually check entire belt for wear, damage or cracks.
  4. If the indicator is out of allowable working range or belt is damaged, replace the belt.

#### **DRIVE BELT TENSION**

There is no manual drive belt tension adjustment. The drive belt tension is automatically adjusted by the auto tensioner.

#### **Changing Engine Coolant**

ELS000YZ

#### **WARNING:**

- To avoid being scalded, never change the coolant when the engine is hot.
- Wrap a thick cloth around the cap to carefully remove the cap. First, turn the cap a quarter of a turn to release any built-up pressure, then push down and turn the cap all the way to remove it.

#### **DRAINING ENGINE COOLANT**

1. Turn ignition switch ON and set temperature control lever all the way to HOT position or the highest temperature position. Wait 10 seconds and turn ignition switch OFF.
2. Remove the engine front undercover using power tool.

# ENGINE MAINTENANCE

3. Open the radiator drain plug at the bottom of the radiator, and remove the radiator filler cap. This is the only step required when partially draining the cooling system (radiator only).

**CAUTION:**

**Do not to allow the coolant to contact the drive belts.**

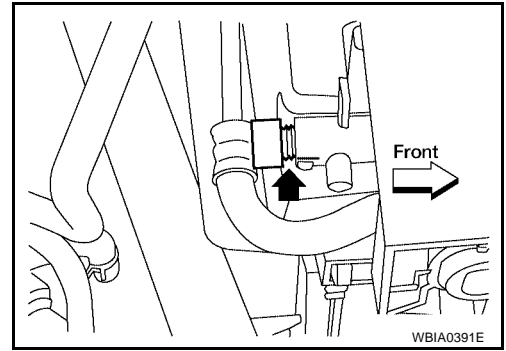

4. When draining all of the coolant in the system for engine removal or repair, it is necessary to drain the cylinder block. Remove the RH cylinder block drain plug to drain the right bank and the oil cooler hose to drain the left bank as shown.

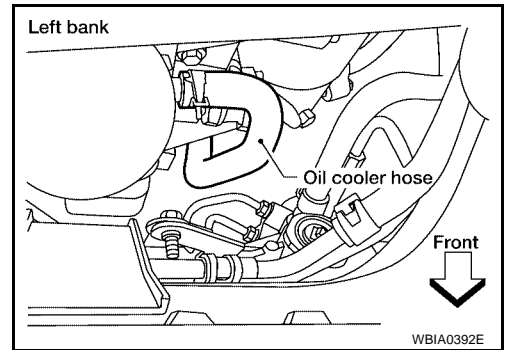
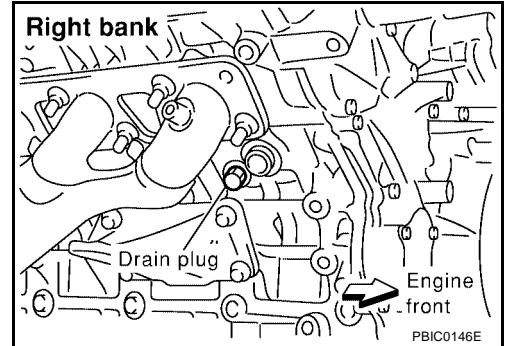

5. Remove the reservoir tank to drain the engine coolant, then clean the reservoir tank before installing it.
6. Check the drained coolant for contaminants such as rust, corrosion or discoloration. If the coolant is contaminated, flush the engine cooling system. Refer to [MA-14, "FLUSHING COOLING SYSTEM"](#).

## REFILLING ENGINE COOLANT

1. Close the radiator drain plug. Install the reservoir tank, cylinder block drain plug, and the oil cooler hose, if removed for a total system drain or for engine removal or repair.
  - The radiator must be completely empty of coolant and water.
  - Apply sealant to the threads of the cylinder block drain plug. Use Genuine High Performance Thread Sealant or equivalent. Refer to [GI-45, "RECOMMENDED CHEMICAL PRODUCTS AND SEALANTS"](#).

**Radiator drain plug : 1.19 N·m (0.12 kg·m , 11 in·lb)**

**RH cylinder block drain plug : 19.6 N·m (2.0 kg·m, 15 ft·lb)**

2. Set the vehicle heater controls to the full HOT and heater ON position. Turn the vehicle ignition ON with the engine OFF as necessary to activate the heater mode.
3. Remove the vented reservoir cap and replace it with a non-vented reservoir cap before filling the cooling system.

# ENGINE MAINTENANCE

4. Install the Tool by installing the radiator cap adapter onto the radiator neck opening. Then attach the gauge body assembly with the refill tube and the venturi assembly to the radiator cap adapter.
5. Insert the refill hose into the coolant mixture container that is placed at floor level. Make sure the ball valve is in the closed position.
  - Use Genuine NISSAN Long Life Anti-freeze coolant or equivalent, mixed 50/50 with distilled water or demineralized water. Refer to [MA-11, "ANTI-FREEZE COOLANT MIXTURE RATIO"](#).

**Cooling system capacity (with reservoir "MAX" level)** : Refer to [MA-10, "Fluids and Lubricants"](#).

6. Install an air hose to the venturi assembly, the air pressure must be within specification.

**Compressed air supply pressure** : 5.7 - 8.5 kPa (5.6 - 8.4 kg/cm<sup>2</sup>, 80 - 120 psi)

**CAUTION:**

**The compressed air supply must be equipped with an air dryer.**

7. The vacuum gauge will begin to rise and there will be an audible hissing noise. During this process open the ball valve on the refill hose slightly. Coolant will be visible rising in the refill hose. Once the refill hose is full of coolant, close the ball valve. This will purge any air trapped in the refill hose.
8. Continue to draw the vacuum until the gauge reaches 28 inches of vacuum. The gauge may not reach 28 inches in high altitude locations, refer to the vacuum specifications based on the altitude above sea level.

Altitude above sea level	Vacuum gauge reading
0 - 100 m (328 ft)	: 28 inches of vacuum
300 m (984 ft)	: 27 inches of vacuum
500 m (1,641 ft)	: 26 inches of vacuum
1,000 m (3,281 ft)	: 24 - 25 inches of vacuum

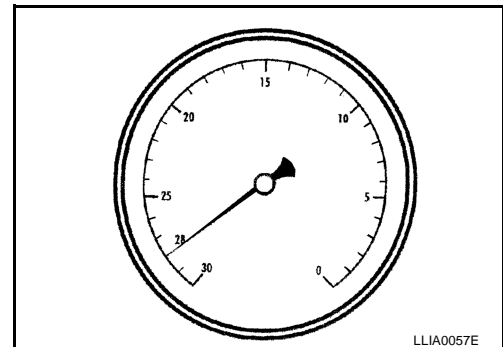
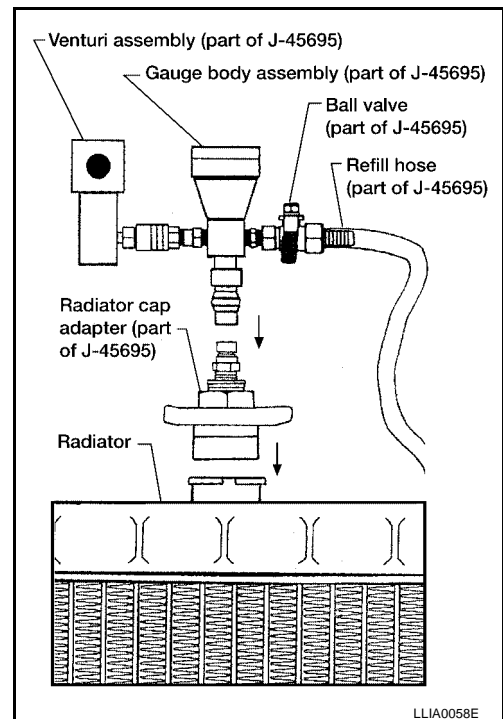

9. When the vacuum gauge has reached the specified amount, disconnect the air hose and wait 20 seconds to see if the system loses any vacuum. If the vacuum level drops, perform any necessary repairs to the system and repeat steps 6 - 8 to bring the vacuum to the specified amount. Recheck for any leaks.
10. Place the coolant container (with the refill hose inserted) at the same level as the top of the radiator. Then open the ball valve on the refill hose so the coolant will be drawn up to fill the cooling system. The cooling system is full when the vacuum gauge reads zero.

**CAUTION:**

**Do not allow the coolant container to get too low when filling, to avoid air from being drawn into the cooling system.**

11. Remove the Tool from the radiator neck opening and install the radiator cap.
12. Remove the non-vented reservoir cap.
13. Fill the cooling system reservoir tank to the specified level. Run the engine to warm up the cooling system and top up the system as necessary before installing the vented reservoir cap.

## FLUSHING COOLING SYSTEM

1. Drain the water from the engine cooling system. Refer to [MA-12, "DRAINING ENGINE COOLANT"](#).
2. Fill the radiator and the reservoir tank (to the "MAX" line), with water. Reinstall the radiator cap and leave the vented reservoir cap off.
3. Run the engine until it reaches normal operating temperature.

# ENGINE MAINTENANCE

4. Press the engine accelerator two or three times under no-load.
5. Stop the engine and wait until it cools down.
6. Drain the water from the engine cooling system. Refer to [MA-12, "DRAINING ENGINE COOLANT"](#).
7. Repeat steps 2 through 6 until clear water begins to drain from the radiator.

## Checking Fuel Lines

Inspect the fuel lines and fuel tank for improper mounting, leaks, cracks, damage, loose connections, chafing, or deterioration. As necessary, repair or replace any faulty parts.

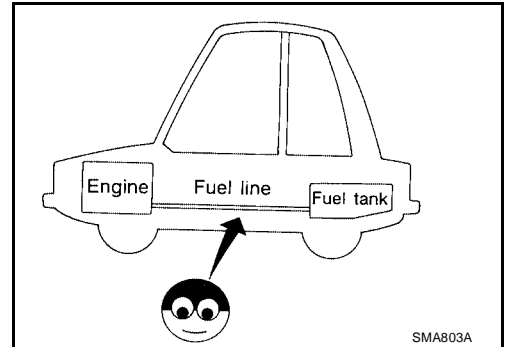

## Changing Fuel Filter

The fuel filter is part of the fuel level sensor unit, fuel filter and fuel pump assembly. Refer to [FL-5, "FUEL LEVEL SENSOR UNIT, FUEL FILTER AND FUEL PUMP ASSEMBLY"](#).

### WARNING:

Before replacing the fuel filter, release the fuel pressure from the fuel system. Refer to [EC-46, "FUEL PRESSURE RELEASE"](#).

## Changing Engine Air Cleaner Filter VISCIOUS PAPER TYPE

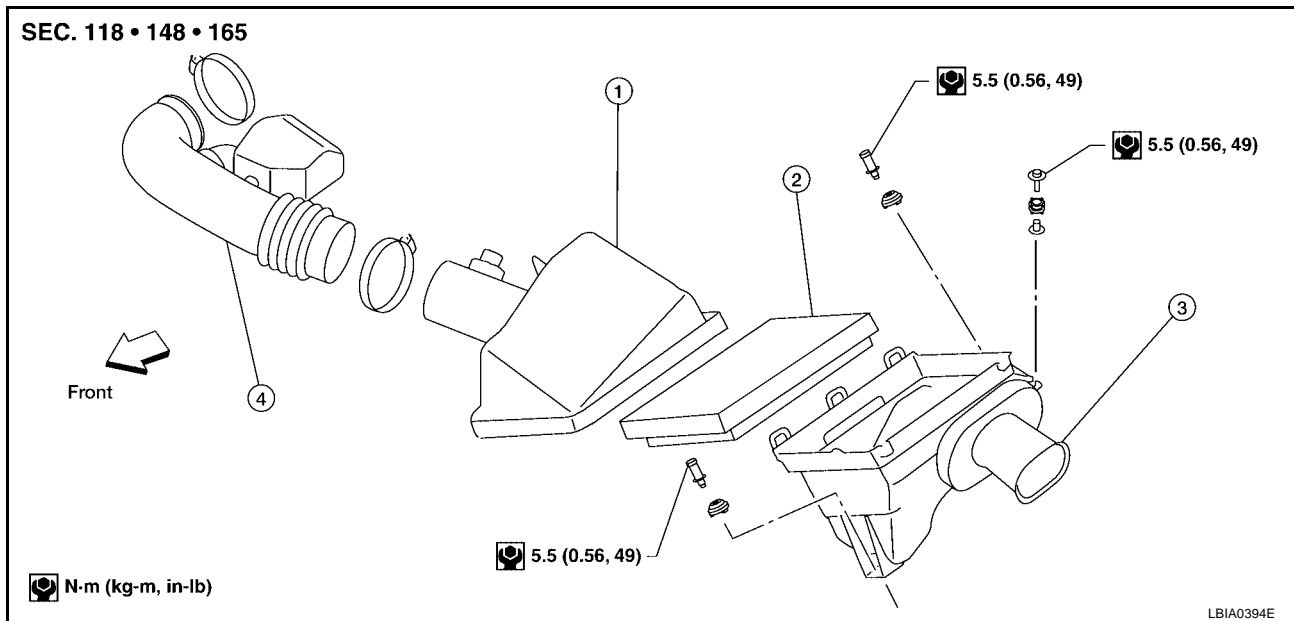

1. Air cleaner case (upper)
2. Air cleaner filter
3. Air cleaner case (lower)
4. Air duct and resonator assembly

### NOTE:

- The viscous paper type filter does not need cleaning between replacement intervals.
  - Replace the air filter as necessary for required maintenance.
1. Remove the air duct and resonator assembly (inlet).
  2. Remove the air cleaner case (upper).
  3. Remove the air cleaner filter from the air cleaner case (lower).
  4. Install the new air cleaner filter in the air cleaner case (lower).
  5. Install the air cleaner case (upper).

# ENGINE MAINTENANCE

6. Install the air duct and resonator assembly (inlet).

## Changing Engine Oil

ELS000Z3

### WARNING:

- Be careful not to burn yourself, as the engine oil is hot.
  - Prolonged and repeated contact with used engine oil may cause skin cancer; try to avoid direct skin contact with used oil. If skin contact is made, wash thoroughly with soap or hand cleaner as soon as possible.
1. Warm up the engine, and check for any oil leaks.
  2. Stop the engine and wait for at least 10 minutes.
  3. Remove the oil drain plug and oil filler cap.
  4. Drain the engine oil and refill with new engine oil.

### Oil Specification and Viscosity

- API grade SL, Energy Conserving
- API Certification Mark
- ILSAC grade GF-III
- See [MA-10, "RECOMMENDED FLUIDS AND LUBRICANTS"](#) .

### Refill Oil Capacity (Approximately)

Unit: ℓ (US qt, Imp qt)

Drain and refill	Capacity
with oil filter change	6.2 (6 1/2, 5 1/2)
without oil filter change	5.9 (6 1/4, 5 1/4)
Dry engine (engine overhaul)	7.6 (8, 6 3/4)

### CAUTION:

- Clean the drain plug and install with a new washer.
- Oil pan drain plug : 34.3 N-m (3.5 kg-m, 25 ft-lb)**
- The refill capacity depends on the oil temperature and drain time. Use the “Refill oil capacity” values as a reference and check the oil level using the dipstick when filling the oil.
5. Warm up the engine and check the area around the drain plug and oil filter for any oil leaks.
  6. Stop the engine and wait for more than 10 minutes.
  7. Check the oil level using the dipstick as shown.

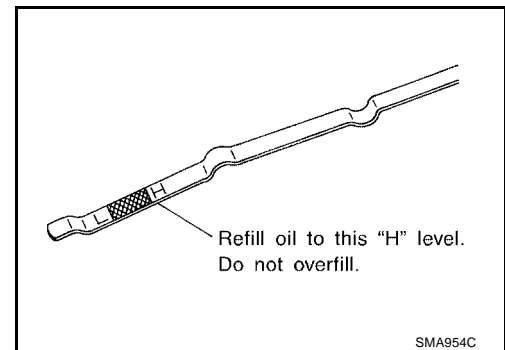

## Changing Oil Filter

ELS000Z4

1. Remove the oil filter using Tool.

**Tool number : KV10115801 (J-38956)**

The filter is a full-flow cartridge type and is provided with a relief valve.

### WARNING:

Be careful not to burn yourself, as the engine and engine oil are hot.



# ENGINE MAINTENANCE

2. Clean the oil filter mounting surface on the cylinder block. Coat the oil filter rubber seal with engine oil as shown.

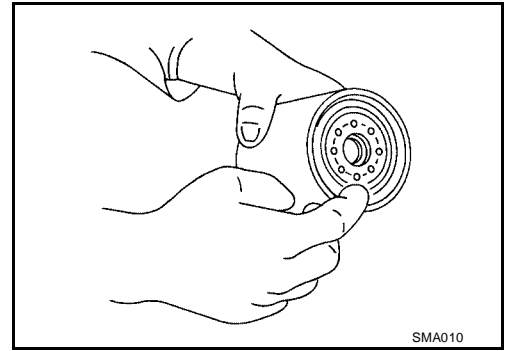

3. Screw on the oil filter until a slight resistance is felt, then tighten the oil filter an additional 2/3 turn as shown.
4. Add new engine oil. Refer to [MA-16, "Changing Engine Oil"](#).
  - Clean any oil spills off the engine.

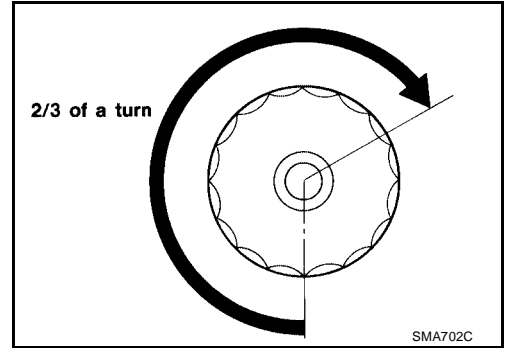

## Changing Spark Plugs

ELS00025

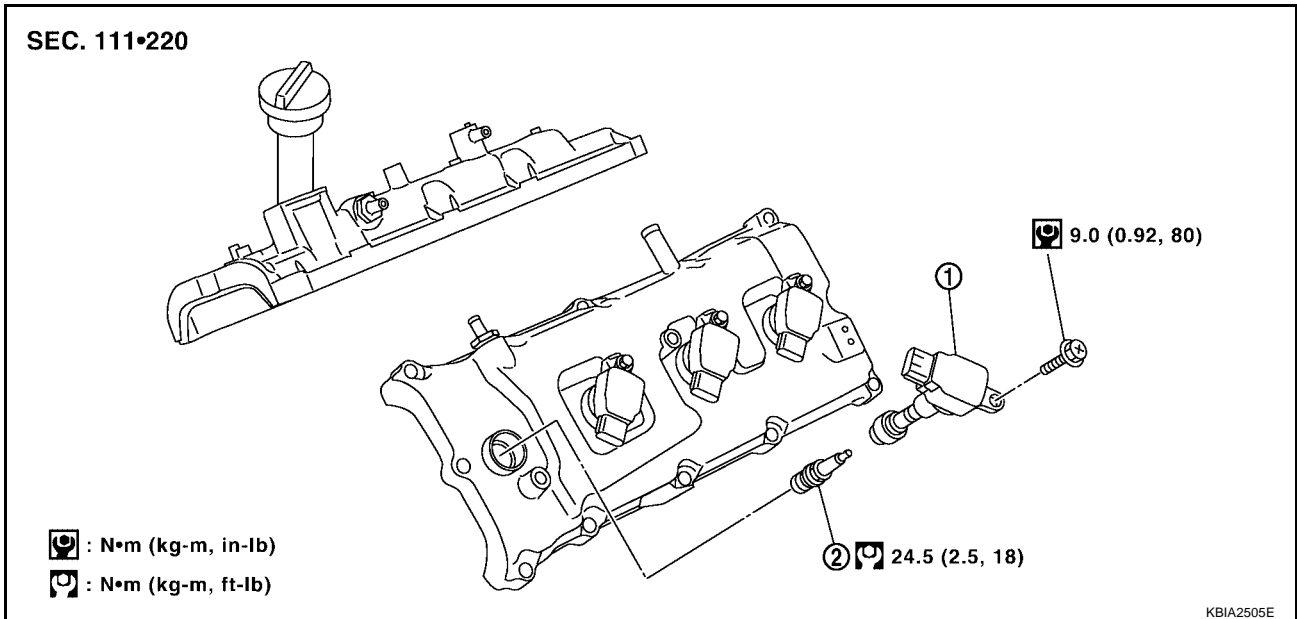

1. Ignition coil

2. Spark plug

## REMOVAL

1. Disconnect harness connector from ignition coil.
2. Remove ignition coil. Refer to [EM-26, "IGNITION COIL"](#).

# ENGINE MAINTENANCE

3. Using a suitable tool remove spark plug with.

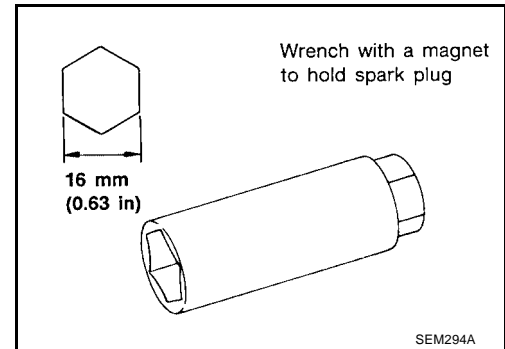

## INSPECTION AFTER REMOVAL

Use standard type spark plug for normal condition.

The hot type spark plug is suitable when fouling occurs with the standard type spark plug under conditions such as:

- Frequent engine starts
- Low ambient temperatures

The cold type spark plug is suitable when spark knock occurs with the standard type spark plug under conditions such as:

- Extended highway driving
- Frequent high engine revolution

Make	NGK
Standard type	PLFR5A-11
Hot type	PLFR4A-11
Cold type	PLFR6A-11

**Gap (nominal) : 1.1 mm (0.043 in)**

### CAUTION:

- Do not drop or shock spark plug.
- Do not use a wire brush for cleaning.

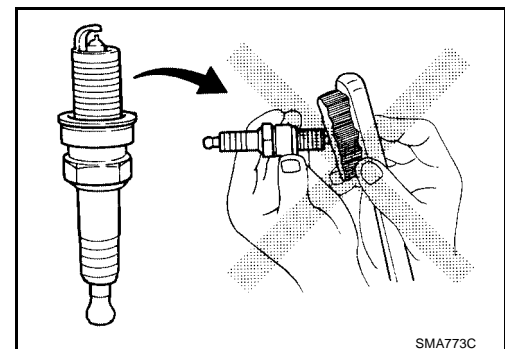

- If plug tip is covered with carbon, spark plug cleaner may be used.

**Cleaner air pressure : Less than 588 kPa (5.9 bar, 6 kg/cm<sup>2</sup>, 85 psi)**

**Cleaning time : Less than 20 seconds**

# ENGINE MAINTENANCE

- Checking and adjusting plug gap is not required between change intervals.

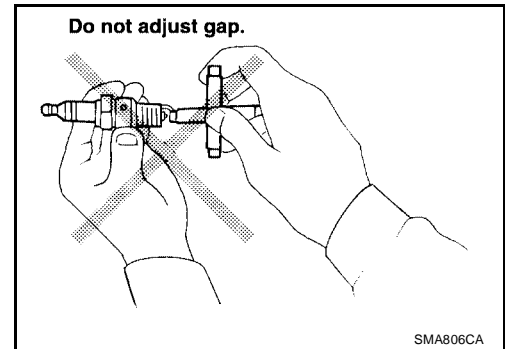

## INSTALLATION

Installation is in the reverse order of removal.

## Checking EVAP Vapor Lines

ELS00026

1. Visually inspect EVAP vapor lines for improper attachment, cracks, damage, loose connections, chafing or deterioration.
2. Inspect vacuum relief valve of fuel tank filler cap for clogging, sticking, etc.  
Refer to [EC-609, "How to Detect Fuel Vapor Leakage"](#).

A  
B  
C  
D  
E  
F  
G  
H  
I  
J  
K  
MA  
M

# CHASSIS AND BODY MAINTENANCE

## CHASSIS AND BODY MAINTENANCE

PFP:00100

EL.S000Z7

### Changing In-cabin Microfilter

1. Remove the glove box assembly.
  - a. Remove the two lower glove box screws.

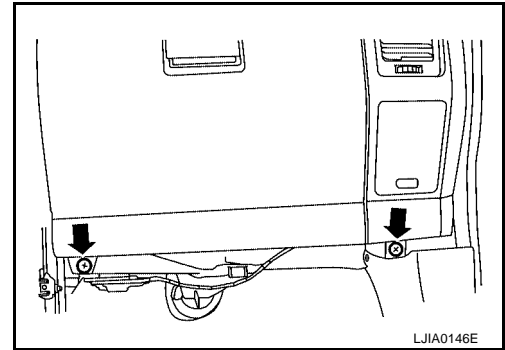

- b. Open the glove box, then remove the four upper glove box screws.

**NOTE:**

It is not necessary to remove the two glove box striker screws.

- c. Remove the glove box assembly from the instrument panel to access the in-cabin microfilter cover.

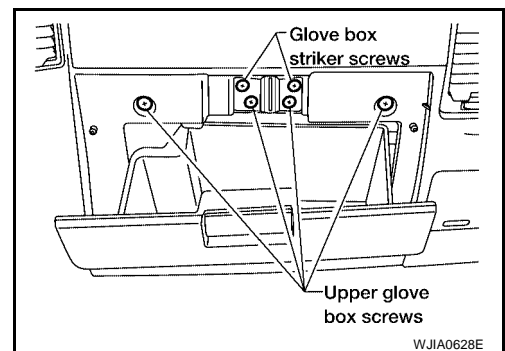

2. Remove the screw and remove the in-cabin microfilter cover.
3. Remove the in-cabin microfilters from the front heater and cooling unit assembly housing.

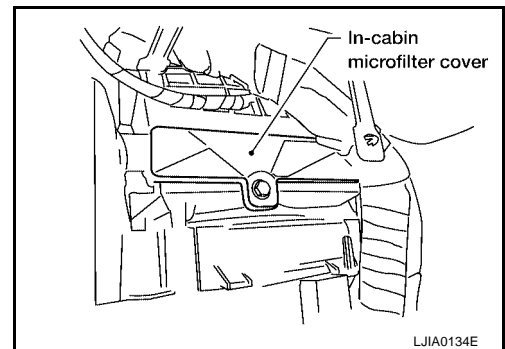

4. Insert the first new in-cabin microfilter into the front heater and cooling unit assembly housing and slide it over to the right. Insert the second new in-cabin microfilter into the front heater and cooling unit assembly housing.

**NOTE:**

The in-cabin microfilters are marked with air flow arrows. The end of the microfilter with the arrow should face the rear of the vehicle. The arrows should point downward.

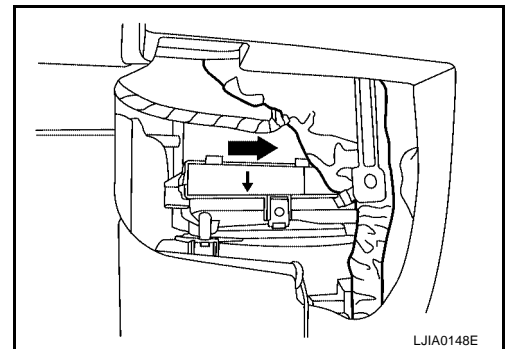

# CHASSIS AND BODY MAINTENANCE

5. Install the in-cabin microfilter cover.

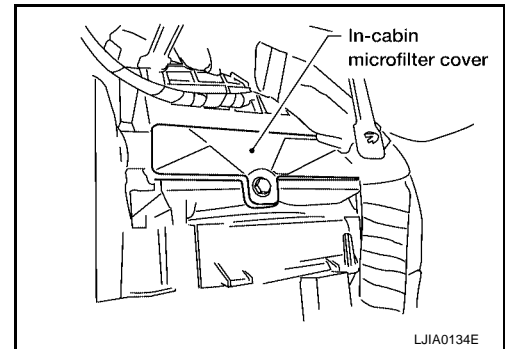

6. Install the glove box assembly in reverse order of removal.

**Lower glove box screws** : 3.5 N-m (0.36 kg-m, 31 in-lb)

**Upper glove box screws** : 3.5 N-m (0.36 kg-m, 31 in-lb)

## Checking Exhaust System

Check exhaust pipes, muffler and mounting for improper attachment, leaks, cracks, damage, loose connections, chafing or deterioration.

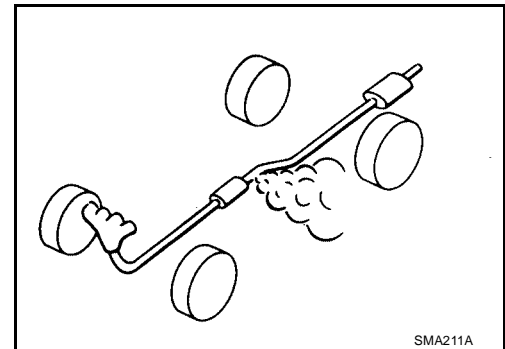

ELS00028

## Checking A/T Fluid

1. Warm up the engine.
2. Check for any fluid leaks.
3. Remove the ATF level gauge bolt.
4. Before driving, the fluid level can be checked at fluid temperatures of 30° to 50°C (86° to 122°F) using the "COLD" range on the ATF level gauge as follows:
  - a. Park the vehicle on a level surface and set the parking brake.
  - b. Start the engine and move the selector lever through each gear position. Shift the selector lever into the "P" position.
  - c. Check the fluid level with the engine idling.
  - d. Remove the ATF level gauge and wipe it clean with a lint-free paper.

### CAUTION:

When wiping the fluid from the ATF level gauge, always use a lint-free paper, not a cloth.

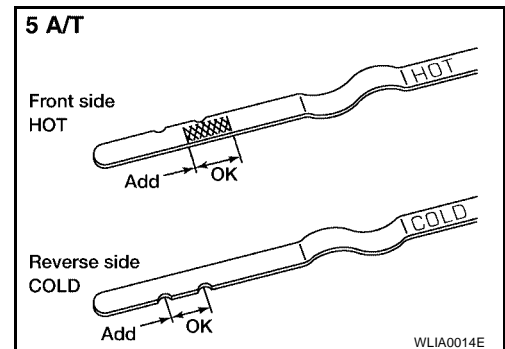

ELS00165

## CHASSIS AND BODY MAINTENANCE

- e. Re-insert the ATF level gauge into the charging pipe until the cap contacts the top of the charging pipe as shown.

**CAUTION:**

To check fluid level, insert the ATF level gauge until the cap contacts the top of the charging pipe, with the gauge reversed from the normal inserted position.

- f. Remove the ATF level gauge and note the fluid level. If the fluid level is at low side of range, add fluid to the transmission through the charging pipe.

**CAUTION:**

Do not overfill the transmission with fluid.

5. Drive the vehicle to increase the ATF temperature to 80° C (176° F).  
6. Allow the ATF temperature to fall to approximately 65° C (149° F). Use the CONSULT-II to monitor the fluid temperature as follows:

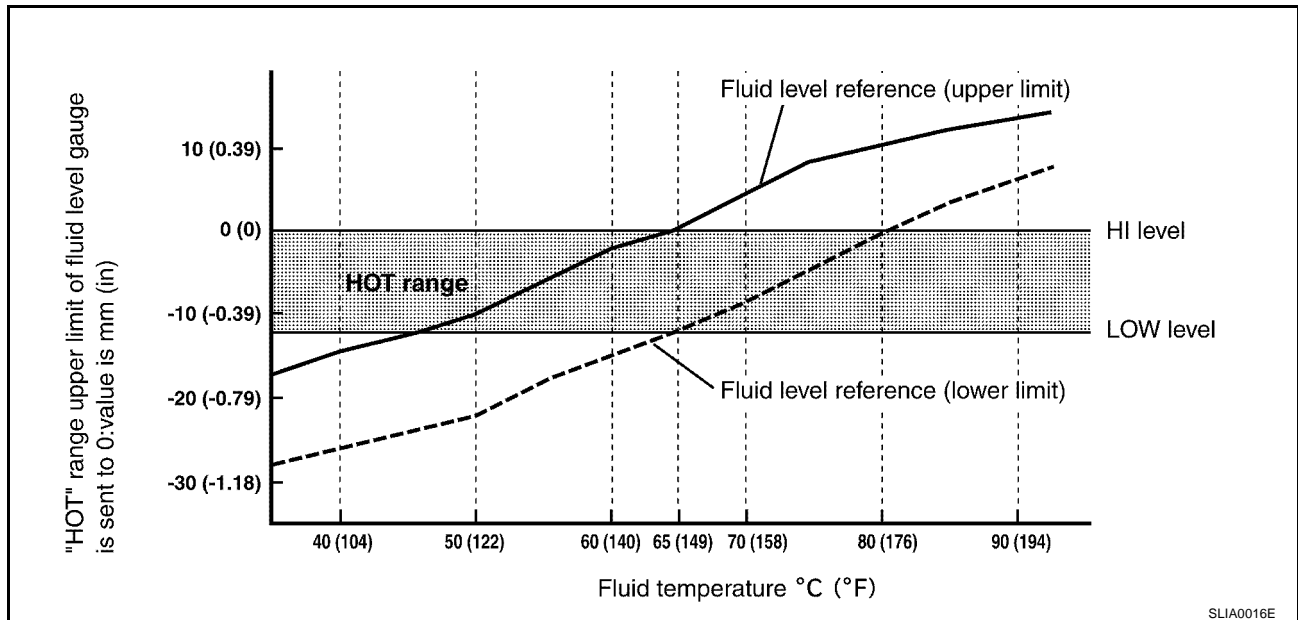
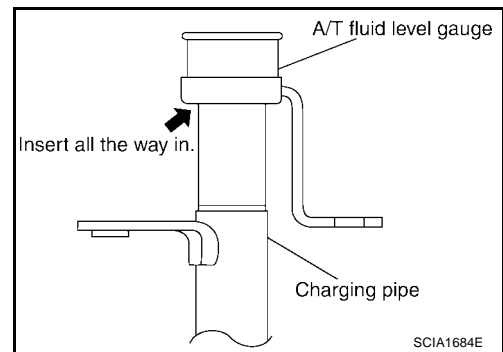

**NOTE:**

Fluid level will be greatly affected by temperature as shown. Therefore monitor the fluid temperature data using the CONSULT-II.

- a. Connect CONSULT-II to data link connector.  
b. Select "MAIN SIGNALS" in "DATA MONITOR" mode for "A/T" with CONSULT-II.  
c. Read out the value of "ATF TEMP 1".  
7. Re-check the fluid level at fluid temperatures of approximately 65° C (149° F) using the "HOT" range on the A/T fluid level gauge as shown.

**CAUTION:**

- When wiping the fluid from the ATF level gauge, always use lint-free paper, not a cloth.

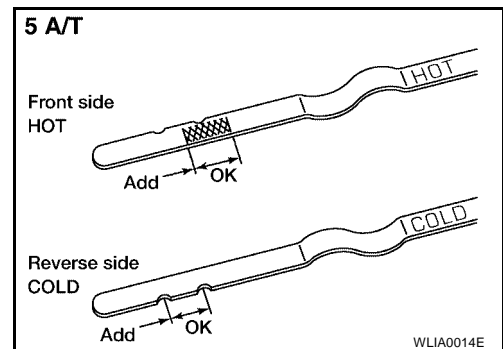

# CHASSIS AND BODY MAINTENANCE

- To check the fluid level, insert the ATF level gauge until the cap contacts the top of the charging pipe, with the gauge reversed from the normal inserted position as shown.
8. Check the fluid condition.
    - If the fluid is very dark or has some burned smell, there may be an internal problem with the transmission. Refer to [AT-199, "TROUBLE DIAGNOSIS FOR SYMPTOMS"](#) . Flush the transmission cooling system after repairing the transmission.
    - If the ATF contains frictional material (clutches, bands, etc.), replace the radiator and flush the transmission cooler lines using cleaning solvent and compressed air after repairing the transmission.
  9. Install the ATF level gauge in the fluid charging pipe and install the level gauge bolt.
  10. Tighten the level gauge bolt to specification.

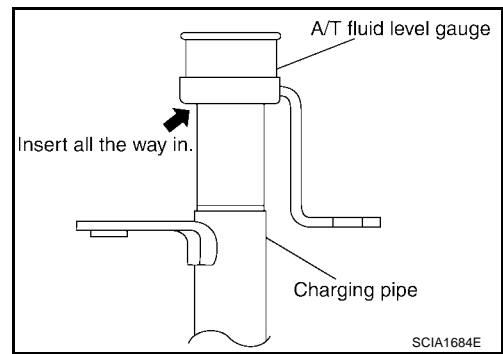

**Level gauge bolt: : 5.1 N-m (0.52 kg-m, 45 in-lb)**

## Changing A/T Fluid

ELS00166

1. Drive the vehicle to warm up the ATF to 80° C (176° F).
2. Stop the engine.
3. Remove the ATF level gauge bolt.
4. Drain the ATF from the drain plug hole and refill the transmission with new ATF. Always refill with the same volume as the drained fluid and use the dipstick to check the fluid level as shown. Add fluid as necessary.

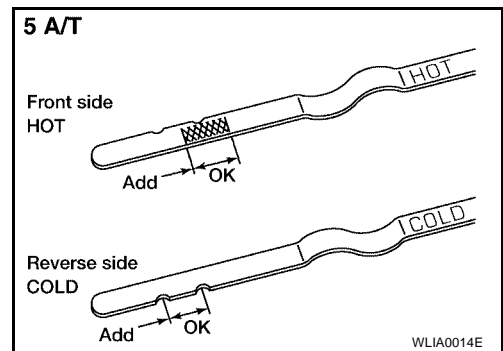

- To flush out the old fluid from the coolers, pour new fluid into the charging pipe with the engine idling and at the same time drain the old fluid from the auxiliary transmission oil cooler hose return line.
- When the color of the fluid coming out of the auxiliary transmission oil cooler hose return line is about the same as the color of the new fluid, flushing out the old fluid is complete. The amount of new transmission fluid used for flushing should be 30% to 50% of the specified capacity.

**Transmission fluid type : Genuine NISSAN Matic Fluid J ATF**

**Transmission fluid capacity : 10.6 ℓ (11 1/4 US qt, 9 3/8 Imp qt)  
(with torque converter)**

### CAUTION:

- Use only Genuine NISSAN ATF Matic Fluid J. Do not mix with other fluid.
- Using automatic transmission fluid other than Genuine NISSAN ATF Matic Fluid J will cause deterioration in driveability and automatic transmission durability, and may damage the automatic transmission, which is not covered by the warranty.
- When filling the transmission with fluid, do not spill the ATF on any heat generating parts such as the exhaust manifold.
- Do not reuse the drain plug gasket.

**Drain plug : 34 N-m (3.5 kg-m, 25 ft-lb)**

5. Drive the vehicle to warm up the ATF to 80° C (176° F).
6. Check the fluid level and condition. Refer to [MA-21, "Checking A/T Fluid"](#) . If the fluid is still dirty, repeat steps 2 through 5.

# CHASSIS AND BODY MAINTENANCE

7. Install the ATF level gauge in the fluid charging pipe and install the level gauge bolt.
8. Tighten the level gauge bolt to specification.

**Level gauge bolt : 5.1 N·m (0.52 kg-m, 45 in-lb)**

## Checking Transfer Fluid

ELS0002B

1. Check for any fluid leaks and correct as necessary.

### NOTE:

ATF is used for the transfer from the factory.

2. Remove the filler plug and check the fluid level as shown. Add any fluid as necessary

**Fluid grade and capacity : Refer to MA-10, "Fluids and Lubricants" .**

### CAUTION:

**Never start the engine while checking the fluid level.**

3. Apply sealant to the filler plug threads.
  - Use High performance Thread Sealant or equivalent. Refer to [GI-45, "RECOMMENDED CHEMICAL PRODUCTS AND SEALANTS"](#) .
4. Install the filler plug and tighten to specification.

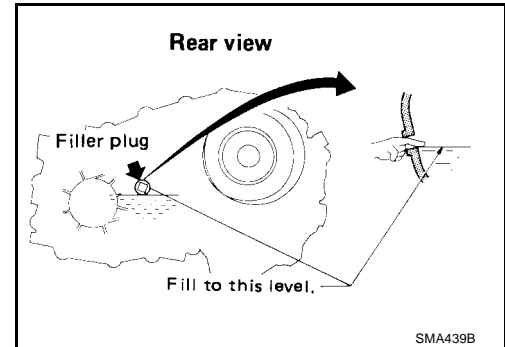

**Filler plug : 35 N·m (3.6 kg-m, 26 ft-lb)**

## Changing Transfer Fluid

ELS0002C

1. Remove the filler plug and the drain plug to drain the transfer fluid as shown.
2. Apply sealant to the drain plug threads.
  - Use Genuine Anaerobic Liquid Gasket or equivalent. Refer to [GI-45, "RECOMMENDED CHEMICAL PRODUCTS AND SEALANTS"](#) .
3. Install the drain plug. Tighten the drain plug to specification.

**Drain plug : 35 N·m (3.6 kg-m, 26 ft-lb)**

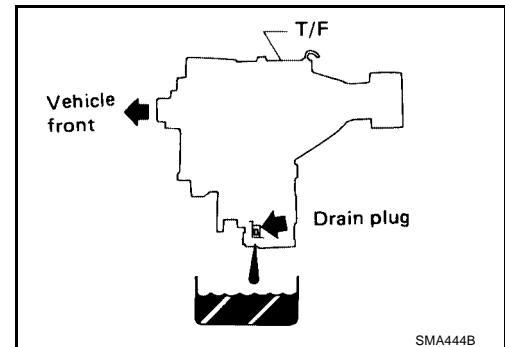

4. Fill the transfer case to the correct level with the specified fluid as shown.

**Fluid grade and capacity : Refer to MA-10, "Fluids and Lubricants" .**

5. Install the filler plug. Tighten the filler plug to specification.

**Filler plug : 35 N·m (3.6 kg-m, 26 ft-lb)**

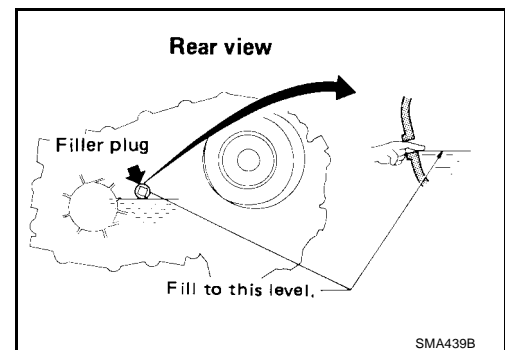

## Checking Propeller Shaft

ELS0002E

Check the front and rear propeller shafts for damage, dents, and cracks. Check the joints for looseness and any damage. Repair or replace as necessary.

## Checking Final Drive Oil

ELS0002F

Check for oil leaks and oil level. Add oil as necessary.

### CAUTION:

**If using the vehicle for towing, the rear final drive oil must be replaced every 5,000 km (3,000 miles) or every three months, whichever comes first.**



# CHASSIS AND BODY MAINTENANCE

- Filler plug** : Refer to [FFD-13, "Components" \(FFD\)](#), [RFD-14, "Removal and Installation" \(RFD without ELD\)](#), [RFD-82, "Removal and Installation" \(RFD with ELD\)](#).
- Oil grade, viscosity** : Refer to [MA-10, "Fluids and Lubricants"](#) .

## Changing Final Drive Oil

ELS000ZG

### CAUTION:

If using the vehicle for towing, the rear final drive oil must be replaced every 5,000 km (3,000 miles) or every three months, whichever comes first.

1. Remove the filler plug.
2. Remove the drain plug and drain the final drive oil.
3. Apply sealant to the drain plug threads.
  - Use High Performance Thread Sealant or equivalent. Refer to [GI-45, "Recommended Chemical Products and Sealants"](#) .
4. Install the drain plug and tighten to specification.

**Drain plug** : Refer to [FFD-13, "Components" \(FFD\)](#), [RFD-14, "Removal and Installation" \(RFD without ELD\)](#), [RFD-82, "Removal and Installation" \(RFD with ELD\)](#).

5. Refill the rear final drive with new specified oil.

**Oil grade and viscosity** : Refer to [MA-10, "Fluids and Lubricants"](#) .

**Oil capacity** : Refer to [MA-10, "Fluids and Lubricants"](#) .

6. Check the oil level.

### NOTE:

Rear final drive shown, front final drive similar

7. Install the filler plug and tighten to specification.

**Filler plug** : Refer to [FFD-13, "Components" \(FFD\)](#), [RFD-14, "Removal and Installation" \(RFD without ELD\)](#), [RFD-82, "Removal and Installation" \(RFD with ELD\)](#).

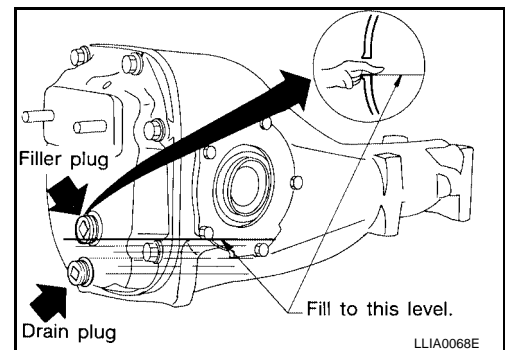

## Balancing Wheels

ELS000ZH

Adjust the wheel balance using the road wheel center.

Wheel type		Aluminum	Steel	
			Inside	Outside
Maximum radial runout limit	Lateral mm (in)	0.3 (0.012) or less	1.0 (0.039) or less	0.9 (0.035) or less
	Radial mm (in)	0.3 (0.012) or less	0.8 (0.031) or less	0.4 (0.016) or less
Maximum residual imbalance	Dynamic (at rim flange)	Less than 10 g (0.35 oz) (per side)		
	Static (at rim flange)	Less than 20 g (0.71 oz)		

# CHASSIS AND BODY MAINTENANCE

## Tire Rotation

ELS000Z1

1. Rotate the tires on each side from front to back as shown.

**Wheel nuts : 133 N·m (14 kg·m, 98 ft·lb)**

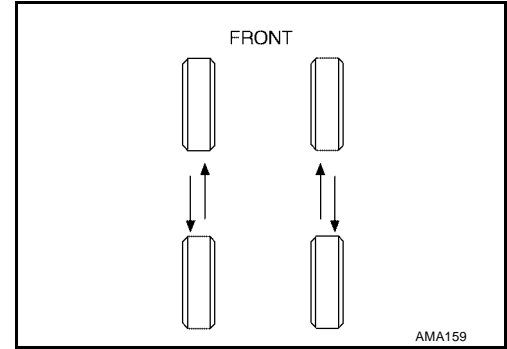

2. Adjust the tire pressure to specification.

Unit: kPa (kg/cm<sup>2</sup>, psi)

Tire size	Air pressure	
	Conventional tire	Spare tire
Full size spare tire	—	240 (2.4, 35)
P285/70R17	240 (2.4, 35)	—
P265/70R18	240 (2.4, 35)	—
P245/75R17	240 (2.4, 35)	—

3. After the tire rotation, retighten the wheel nuts after the vehicle has been driven for 1,000 km (600 miles), and also after a wheel and tire have been installed such as after repairing a flat tire.

## Checking Brake Fluid Level and Leaks

ELS000ZJ

- Check the brake fluid level in the reservoir tank. It should be between the “MAX” and “MIN” lines on the reservoir tank.
- If the fluid level is extremely low, check the brake system.
- If the brake warning lamp comes on when the fluid is at the correct level, check the brake fluid level switch and the parking brake switch.

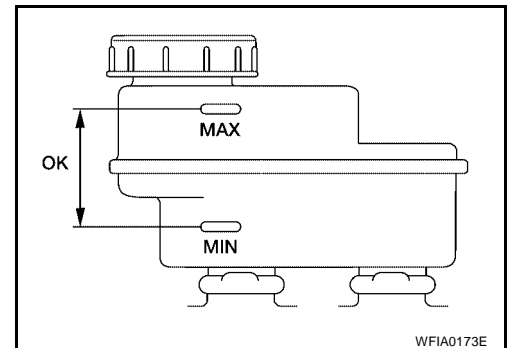

## Checking Brake Lines and Cables

ELS000ZK

1. Check the brake lines and hoses for cracks, deterioration, and other damage. Replace any damaged parts.

### CAUTION:

**If brake fluid leaks are visible around the brake line joints, retighten the joint, or replace damaged parts as necessary.**

2. Check for brake fluid leaks by fully depressing brake pedal while engine is running.

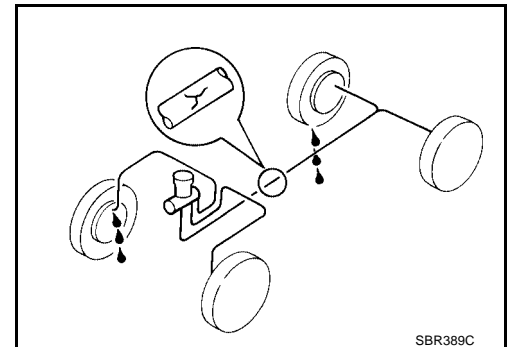

# CHASSIS AND BODY MAINTENANCE

## Checking Disc Brake

ELS000ZL

### ROTOR

Check condition, wear and damage.

**Standard thickness** : 28 mm (1.102 in)

**Repair limit thickness** : 26 mm (1.024 in)

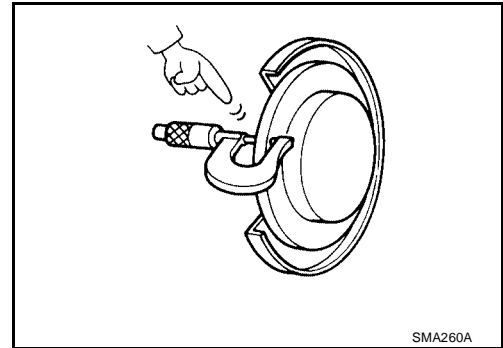

### CALIPER

Check for leakage.

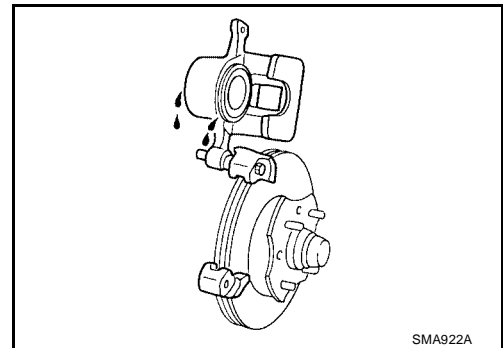

### PAD

Check wear or damage.

**Standard thickness** : 9.5 mm (0.374 in)

**Repair limit thickness** : 2.0 mm (0.079 in)

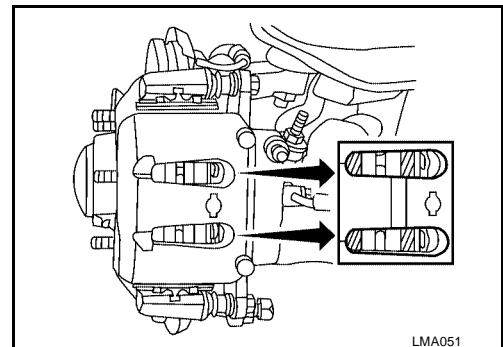

## Checking Steering Gear and Linkage

ELS000ZM

### STEERING GEAR

- Check the steering gear housing for looseness, damage and oil leakage as shown.
- Check the steering column connections for looseness.

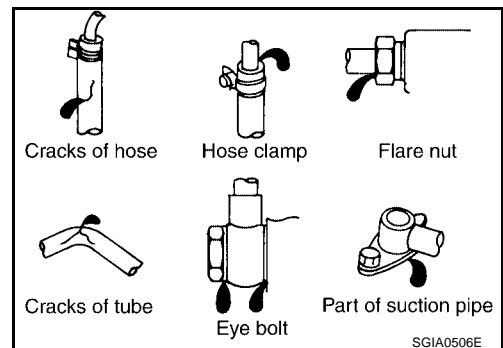

### STEERING LINKAGE

- Check the ball joint, dust cover and other component parts for looseness, wear, damage and grease leakage.

A  
B  
C  
D  
E  
F  
G  
H  
I  
J  
K  
MA

# CHASSIS AND BODY MAINTENANCE

ELS0002N

## Checking Power Steering Fluid and Lines CHECKING FLUID LEVEL

- Check the power steering fluid level with the engine off.
- Check fluid level on reservoir. Use "HOT" range at fluid temperatures of 50° to 80°C (122° to 176°F). Use "COLD" range at fluid temperatures of 0° to 30°C (32° to 86°F).

### CAUTION:

- Do not overfill.
- Recommended fluid is Genuine NISSAN PSF or equivalent. Refer to [MA-10, "Fluids and Lubricants"](#).

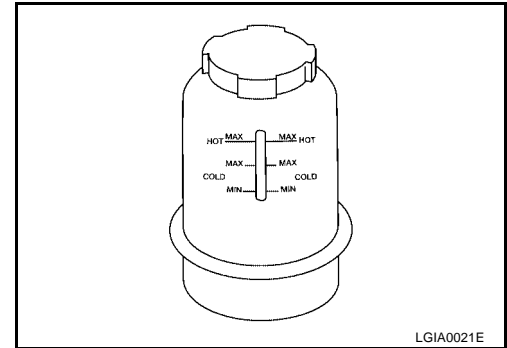

## CHECKING LINES

- Check lines for improper attachment, leaks, cracks, damage, loose connections, chafing and deterioration.

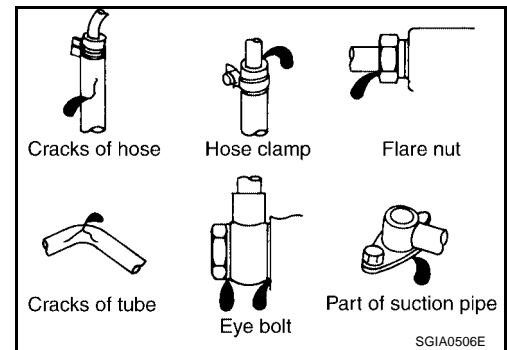

## Checking Axle and Suspension Parts FRONT AND REAR AXLE AND SUSPENSION PARTS

ELS0002O

Check front and rear axle and suspension parts for excessive play, cracks, wear or other damage.

- Shake each wheel to check for excessive play.
- Rotate each wheel to check for abnormal noise.
- Check axle and suspension nuts and bolts for looseness.

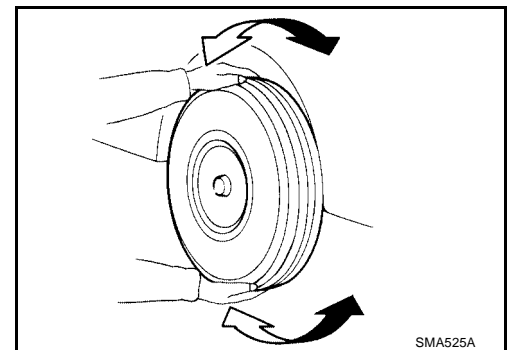

- Check the strut and shock absorber for oil leakage or other damage.
- Check suspension ball joints for grease leakage and ball joint dust cover for cracks or other damage.

## DRIVE SHAFT

Check the boots and drive shaft for cracks, wear, damage, and grease leakage.

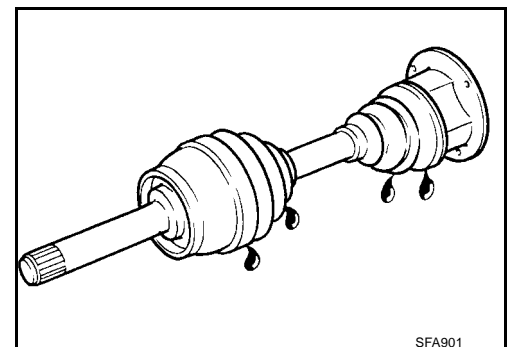

# CHASSIS AND BODY MAINTENANCE

## Lubricating Locks, Hinges and Hood Latches

ELS000ZP

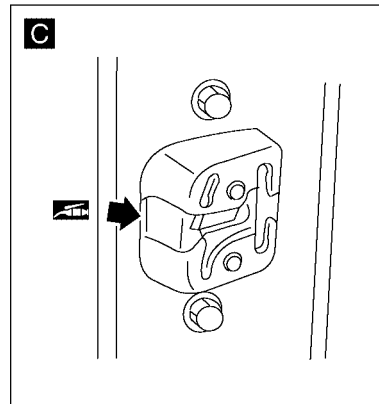
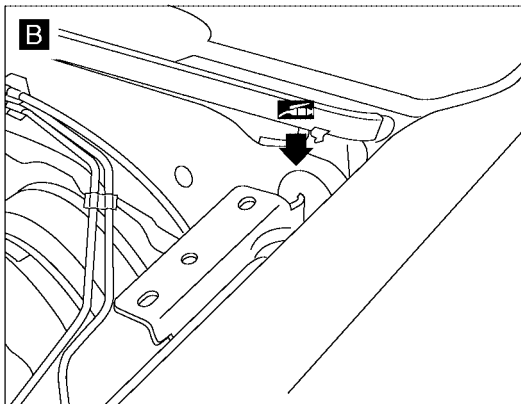
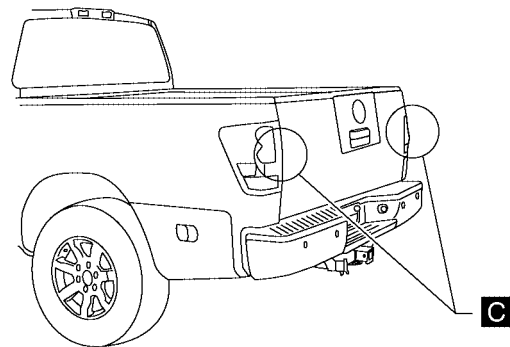
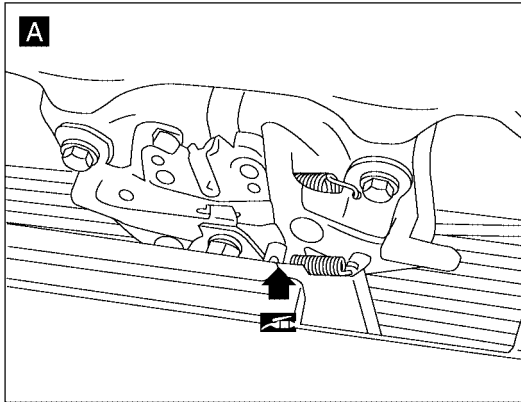
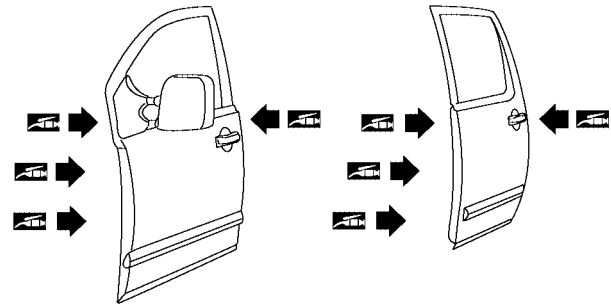
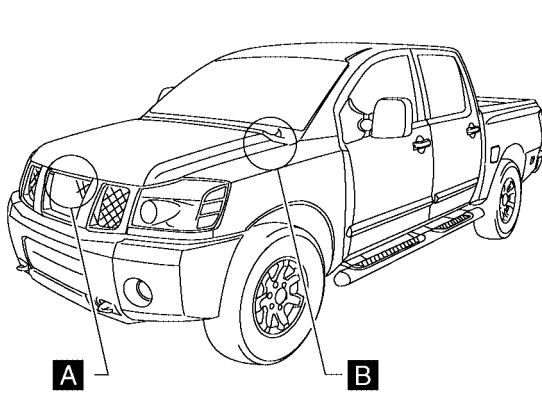

 : Multi-purpose grease

WLIA0019E

### NOTE:

Lubricate the locations shown with a suitable multi-purpose grease. Refer to [MA-10, "Fluids and Lubricants"](#)

A  
B  
C  
D  
E  
F  
G  
H  
I  
J  
K  
MA  
M

# CHASSIS AND BODY MAINTENANCE

## Checking Seat Belts, Buckles, Retractors, Anchors and Adjusters

ELS00020

Check the seat belt buckles, webbing, retractors, anchors and adjusters. Replace any seat belt assembly as necessary. Refer to [SB-10, "Seat Belt Inspection"](#).

- Check the seat belt anchors for loose mounting bolts, damage, or excessive wear.
- Check the seat belt webbing for any damage, cuts, fraying, or excessive wear.
- Check the retractor for smooth operation.
- Check the function of the buckles by inserting the seat belt tongue and checking for proper engagement of the buckle and press the button on the buckle to check for proper release of the seat belt tongue.

### **CAUTION:**

- **After any collision, inspect all seat belt assemblies, including retractors and other attached components, such as the guide rail set. NISSAN recommends replacing all seat belt assemblies in use during a collision, unless they are not damaged and are inspected to confirm they are operating properly after a minor collision.**  
**Also inspect all seat belt assemblies that are not in use during a collision, and replace any components if damaged or not operating properly. The seat belt pre-tensioner should be replaced even if the seat belts are not in use during a frontal collision where the driver and passenger air bags have been deployed.**
- **If any component of the seat belt assembly is suspected of being damaged or not operating properly, do not repair the component. Replace the components as an assembly.**
- **If the seat belt webbing is cut, frayed, or damaged then replace the seat belt assembly.**
- **Never lubricate the seat belt buckle or tongue.**
- **When replacing any seat belt assembly always use a Genuine NISSAN seat belt assembly.**