

LT
SECTION
LIGHTING SYSTEM

A
B
C
D
E
F
G
H
I
J
LT
L
M

CONTENTS

<p>PRECAUTIONS 4</p> <p> Precautions for Supplemental Restraint System (SRS) "AIR BAG" and "SEAT BELT PRE-TENSIONER" 4</p> <p> General precautions for service operations 5</p> <p> Wiring Diagrams and Trouble Diagnosis 5</p> <p>HEADLAMP (FOR USA) 6</p> <p> Component Parts and Harness Connector Location... 6</p> <p> System Description 7</p> <p> OUTLINE 7</p> <p> BATTERY SAVER CONTROL 8</p> <p> AUTO LIGHT OPERATION 8</p> <p> VEHICLE SECURITY SYSTEM (PANIC ALARM)... 8</p> <p> CAN Communication System Description 8</p> <p> Schematic 9</p> <p> Wiring Diagram - H/LAMP - 10</p> <p> Terminals and Reference Value for BCM 14</p> <p> Terminals and Reference Values for IPDM E/R 15</p> <p> How to Proceed With Trouble Diagnosis 15</p> <p> Preliminary Check 16</p> <p> CHECK BCM CONFIGURATION 16</p> <p> CHECK POWER SUPPLY AND GROUND CIRCUIT 16</p> <p> CONSULT-II Functions (BCM) 18</p> <p> CONSULT-II BASIC OPERATION 18</p> <p> WORK SUPPORT 19</p> <p> DATA MONITOR 19</p> <p> ACTIVE TEST 20</p> <p> SELF-DIAGNOSTIC RESULTS 21</p> <p> CONSULT-II Functions (IPDM E/R) 21</p> <p> CONSULT-II OPERATION 21</p> <p> DATA MONITOR 22</p> <p> ACTIVE TEST 23</p> <p> Headlamp HI Does Not Illuminate (Both Sides) 23</p> <p> Headlamp HI Does Not Illuminate (One Side) 25</p> <p> High Beam Indicator Lamp Does Not Illuminate ... 26</p> <p> Headlamp LO Does Not Illuminate (Both Sides) ... 27</p> <p> Headlamp LO Does Not Illuminate (One Side) 29</p> <p> Headlamps Do Not Turn OFF 30</p> <p> Aiming Adjustment 31</p>	<p> LOW BEAM AND HIGH BEAM 31</p> <p> Bulb Replacement 32</p> <p> HEADLAMP (OUTER SIDE), FOR LOW BEAM.. 32</p> <p> HEADLAMP (INNER SIDE), FOR HIGH BEAM.. 32</p> <p> FRONT TURN SIGNAL/PARKING LAMP 32</p> <p> FRONT SIDE MARKER LAMP 32</p> <p> Removal and Installation 34</p> <p> REMOVAL 34</p> <p> INSTALLATION 34</p> <p> Disassembly and Assembly 35</p> <p> DISASSEMBLY 35</p> <p>HEADLAMP (FOR CANADA) - DAYTIME LIGHT SYSTEM - 36</p> <p> Component Parts and Harness Connector Location.. 36</p> <p> System Description 37</p> <p> OUTLINE 37</p> <p> DAYTIME LIGHT OPERATION 37</p> <p> COMBINATION SWITCH READING FUNCTION.. 37</p> <p> AUTO LIGHT OPERATION 37</p> <p> CAN Communication System Description 37</p> <p> Schematic 38</p> <p> Wiring Diagram — DTRL — 39</p> <p> Terminals and Reference Value for BCM 43</p> <p> How to Proceed With Trouble Diagnosis 44</p> <p> Preliminary Check 44</p> <p> CHECK BCM CONFIGURATION 44</p> <p> INSPECTION FOR POWER SUPPLY AND GROUND CIRCUIT 44</p> <p> INSPECTION PARKING BRAKE SWITCH CIRCUIT 45</p> <p> CONSULT-II Functions 46</p> <p> CONSULT-II BASIC OPERATION 46</p> <p> Daytime Light Control Does Not Operate Properly (Normal Headlamps Operate Properly) 46</p> <p> Aiming Adjustment 48</p> <p> Bulb Replacement 48</p> <p> Removal and Installation 48</p> <p> Disassembly and Assembly 48</p> <p>AUTO LIGHT SYSTEM 49</p> <p> Component Parts and Harness Connector Location.. 49</p>
---	---

System Description	50	HAZARD LAMP OPERATION	80
OUTLINE	50	REMOTE KEYLESS ENTRY SYSTEM OPERA-	
COMBINATION SWITCH READING FUNCTION..	50	TION	81
EXTERIOR LAMP BATTERY SAVER CONTROL..	50	COMBINATION SWITCH READING FUNCTION..	81
DELAY TIMER FUNCTION	50	CAN Communication System Description	81
CAN Communication System Description	50	Wiring Diagram — TURN —	82
Major Components and Functions	51	Terminals and Reference Value for BCM	84
Schematic	52	How to Proceed With Trouble Diagnosis	85
Wiring Diagram — AUTO/L —	53	Preliminary Check	86
Terminals and Reference Value for BCM	56	CHECK POWER SUPPLY AND GROUND CIR-	
Terminals and Reference Values for IPDM E/R	57	CUIT	86
How to Proceed With Trouble Diagnosis	58	CONSULT-II Functions	87
Preliminary Check	58	CONSULT-II BASIC OPERATION	87
CHECK BCM CONFIGURATION	58	DATA MONITOR	88
SETTING CHANGE FUNCTIONS	58	ACTIVE TEST	88
CHECK POWER SUPPLY AND GROUND CIR-		Turn Signal Lamp Does Not Operate	89
CUIT	58	Rear Turn Signal Lamp Does Not Operate	90
CONSULT-II Functions (BCM)	60	Hazard Warning Lamp Does Not Operate But Turn	
CONSULT-II BASIC OPERATION	60	Signal Lamps Operate	91
WORK SUPPORT	61	Turn Signal Indicator Lamp Does Not Operate	92
DATA MONITOR	61	Bulb Replacement (Front Turn Signal Lamp)	93
ACTIVE TEST	62	Bulb Replacement (Rear Turn Signal Lamp)	93
SELF-DIAGNOSTIC RESULTS	62	Removal and Installation of Front Turn Signal Lamp..	93
CONSULT-II Functions (IPDM E/R)	63	Removal and Installation of Rear Turn Signal Lamp..	93
CONSULT-II OPERATION	63	LIGHTING AND TURN SIGNAL SWITCH	94
DATA MONITOR	64	Removal and Installation	94
ACTIVE TEST	64	REMOVAL	94
Trouble Diagnosis Chart by Symptom	65	INSTALLATION	94
Lighting Switch Inspection	65	HAZARD SWITCH	95
Optical Sensor System Inspection	66	Removal and Installation	95
Removal and Installation of Optical Sensor	67	REMOVAL	95
REMOVAL	67	INSTALLATION	95
INSTALLATION	67	COMBINATION SWITCH	96
FRONT FOG LAMP	68	Wiring Diagram — COMBSW —	96
Component Parts and Harness Connector Location..	68	Combination Switch Reading Function	97
System Description	69	CONSULT-II Functions	97
OUTLINE	69	CONSULT-II BASIC OPERATION	97
COMBINATION SWITCH READING FUNCTION..	69	DATA MONITOR	98
EXTERIOR LAMP BATTERY SAVER CONTROL..	69	Combination Switch Inspection	99
CAN Communication System Description	69	Removal and Installation	101
Wiring Diagram — F/FOG —	70	Switch Circuit Inspection	101
Terminals and Reference Value for BCM	72	STOP LAMP	102
Terminals and Reference Values for IPDM E/R	73	System Description	102
How to Proceed With Trouble Diagnosis	73	Wiring Diagram — STOP/L —	103
Preliminary Check	74	High-Mounted Stop Lamp	105
CHECK BCM CONFIGURATION	74	BULB REPLACEMENT	105
CHECK POWER SUPPLY AND GROUND CIR-		REMOVAL AND INSTALLATION	105
CUIT	74	Stop Lamp	105
CONSULT-II Functions	75	BULB REPLACEMENT	105
Front Fog Lamps Do Not Illuminate (Both Sides) ...	75	REMOVAL AND INSTALLATION	105
Front Fog Lamp Does Not Illuminate (One Side) ...	76	BACK-UP LAMP	106
Aiming Adjustment	77	Wiring Diagram — BACK/L —	106
Bulb Replacement	78	Bulb Replacement	107
Removal and Installation	78	Removal and Installation	107
TURN SIGNAL AND HAZARD WARNING LAMPS..	79	PARKING, LICENSE PLATE AND TAIL LAMPS ...	108
Component Parts and Harness Connector Location..	79	Component Parts and Harness Connector Location	108
System Description	80	System Description	109
OUTLINE	80	OPERATION BY LIGHTING SWITCH	109
TURN SIGNAL OPERATION	80	COMBINATION SWITCH READING FUNCTION	109

EXTERIOR LAMP BATTERY SAVER CONTROL	109	SWITCH OPERATION	132	
CAN Communication System Description	109	ROOM LAMP TIMER OPERATION	132	A
Schematic	110	INTERIOR LAMP BATTERY SAVER CONTROL	133	
Wiring Diagram — TAIL/L —	111	Schematic	134	B
Terminals and Reference Value for BCM	114	Wiring Diagram — INT/L —	137	
Terminals and Reference Values for IPDM E/R	115	Terminals and Reference Value for BCM	145	B
How to Proceed With Trouble Diagnosis	115	How to Proceed With Trouble Diagnosis	146	
Preliminary Check	116	Preliminary Check	146	C
CHECK POWER SUPPLY AND GROUND CIRCUIT	116	INSPECTION FOR POWER SUPPLY AND GROUND CIRCUIT	146	
CONSULT-II Functions	117	CONSULT-II Functions	147	C
Parking, License Plate and/or Tail Lamps Do Not Illuminate	117	CONSULT-II BASIC OPERATION	147	D
Parking, License Plate and Tail Lamps Do Not Turn OFF (After Approx. 10 Minutes)	120	WORK SUPPORT	148	
Front Parking Lamp	121	DATA MONITOR	148	E
BULB REPLACEMENT	121	ACTIVE TEST	149	
Tail Lamp	121	Front Room/Map Lamp Assembly Control Does Not Operate	149	E
BULB REPLACEMENT	121	Personal Lamp 2nd Row Control Does Not Operate (Room/Map Lamps Operate)	151	F
REAR COMBINATION LAMP	122	All Step/Foot/Puddle Lamps Do Not Operate	152	F
Bulb Replacement	122	All Interior Room Lamps Do Not Operate	153	
Removal and Installation	122	ILLUMINATION	154	G
	122	Component Parts and Harness Connector Location	154	
TRAILER TOW	123	System Description	155	
Component Parts and Harness Connector Location	123	ILLUMINATION OPERATION BY LIGHTING SWITCH	155	H
System Description	124	EXTERIOR LAMP BATTERY SAVER CONTROL	156	
TRAILER TAIL LAMP OPERATION	124	CAN Communication System Description	156	I
TRAILER TURN SIGNAL AND HAZARD LAMP OPERATION	124	Schematic	157	
TRAILER STOP LAMP OPERATION	124	Wiring Diagram — ILL —	160	I
TRAILER POWER SUPPLY OPERATION	125	Removal and Installation	169	
Schematic	126	ILLUMINATION CONTROL SWITCH	169	J
Wiring Diagram — T/TOW —	127	BULB SPECIFICATIONS	170	
INTERIOR ROOM LAMP	130	Headlamp	170	
Component Parts and Harness Connector Location	130	Exterior Lamp	170	LT
System Description	131	Interior Lamp/Illumination	170	
POWER SUPPLY AND GROUND	131			

PRECAUTIONS

PRECAUTIONS

PF0:00011

Precautions for Supplemental Restraint System (SRS) “AIR BAG” and “SEAT BELT PRE-TENSIONER”

EKS00731

The Supplemental Restraint System such as “AIR BAG” and “SEAT BELT PRE-TENSIONER”, used along with a front seat belt, helps to reduce the risk or severity of injury to the driver and front passenger for certain types of collision. This system includes seat belt switch inputs and dual stage front air bag modules. The SRS system uses the seat belt switches to determine the front air bag deployment, and may only deploy one front air bag, depending on the severity of a collision and whether the front occupants are belted or unbelted. Information necessary to service the system safely is included in the SRS and SB section of this Service Manual.

WARNING:

- To avoid rendering the SRS inoperative, which could increase the risk of personal injury or death in the event of a collision which would result in air bag inflation, all maintenance must be performed by an authorized NISSAN/INFINITI dealer.
- Improper maintenance, including incorrect removal and installation of the SRS, can lead to personal injury caused by unintentional activation of the system. For removal of Spiral Cable and Air Bag Module, see the SRS section.
- Do not use electrical test equipment on any circuit related to the SRS unless instructed to in this Service Manual. SRS wiring harnesses can be identified by yellow and/or orange harnesses or harness connectors.

PRECAUTIONS

General precautions for service operations

EKS007TJ

- Never work with wet hands.
- Turn the lighting switch OFF before disconnecting and connecting the connector.
- When checking the headlamp on/off operation, check it on vehicle and with the power connected to the vehicle-side connector.
- Do not touch the headlamp bulb glass surface with bare hands or allow oil or grease to get on it. Do not touch the headlamp bulb just after the headlamp is turned off, because it is very hot.
- When the bulb has burned out, wrap it in a thick vinyl bag and discard. Do not break the bulb.
- Leaving the bulb removed from the headlamp housing for a long period of time can deteriorate the performance of the lens and reflector (dirt, clouding). Always prepare a new bulb and have it on hand when replacing the bulb.
- Do not use organic solvent (paint thinner or gasoline) to clean lamps and to remove old sealant.

Wiring Diagrams and Trouble Diagnosis

EKS00733

When you read wiring diagrams, refer to the following:

- Refer to [GI-15, "How to Read Wiring Diagrams"](#) in GI section.
- Refer to [PG-4, "POWER SUPPLY ROUTING CIRCUIT"](#) for power distribution in PG section.

When you perform trouble diagnosis, refer to the following:

- Refer to [GI-11, "HOW TO FOLLOW TEST GROUPS IN TROUBLE DIAGNOSES"](#) in GI section.
- Refer to [GI-27, "How to Perform Efficient Diagnosis for an Electrical Incident"](#) in GI section.

A

B

C

D

E

F

G

H

I

J

LT

L

M

HEADLAMP (FOR USA)

HEADLAMP (FOR USA)

PFP:26010

Component Parts and Harness Connector Location

EKS00734

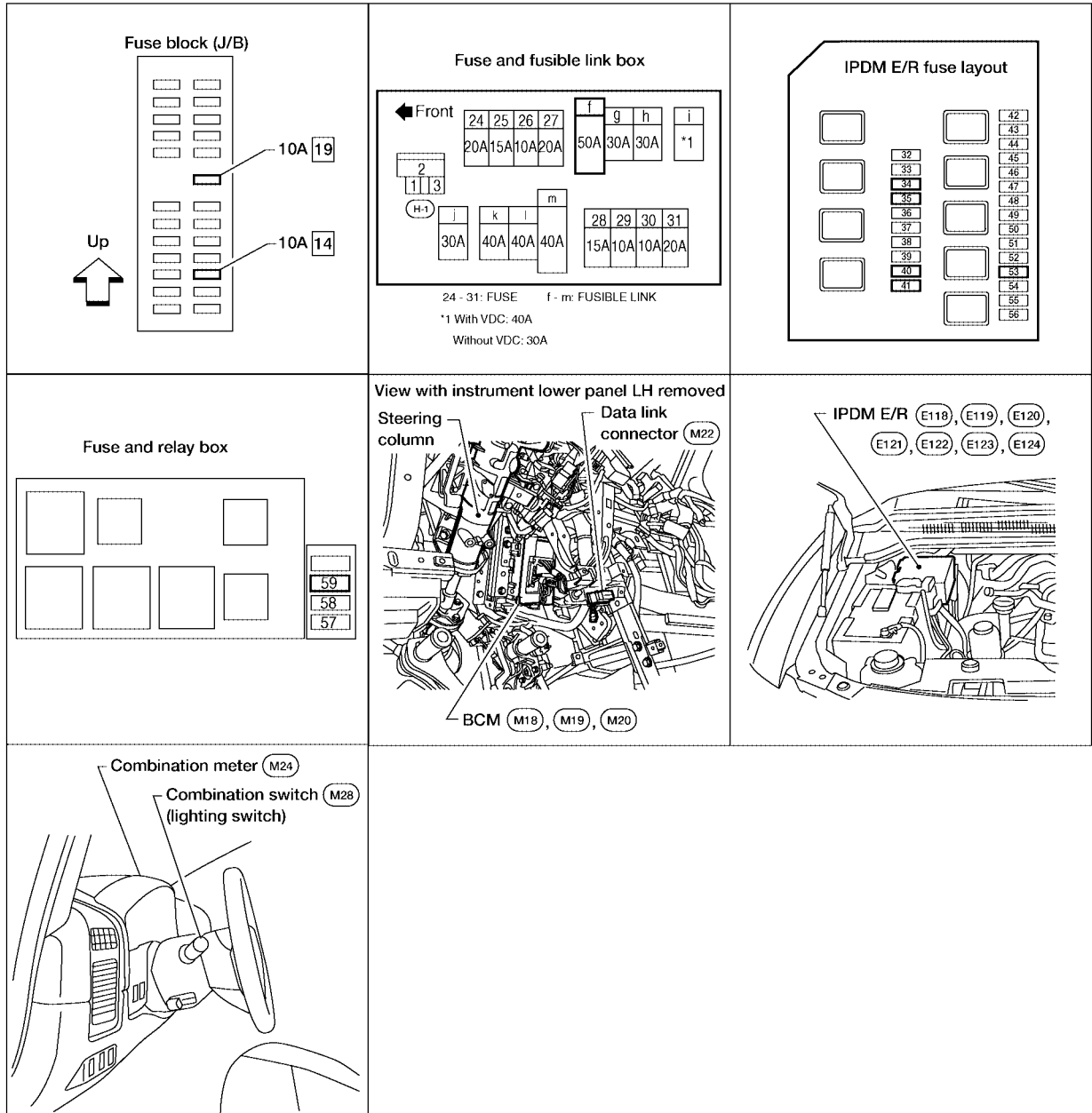

WKIA2826E

HEADLAMP (FOR USA)

EKS00735

System Description

Control of the headlamp system operation is dependent upon the position of the combination switch (lighting switch). When the lighting switch is placed in the 2ND position, the BCM (body control module) receives input requesting the headlamps (and tail lamps) illuminate. This input is communicated to the IPDM E/R (intelligent power distribution module engine room) across the CAN communication lines. The central processing unit of the IPDM E/R controls the headlamp high and headlamp low relay coils. When energized, these relays direct power to the respective headlamps, which then illuminate.

OUTLINE

Power is supplied at all times

- to headlamp high relay, located in the IPDM E/R, and
- to headlamp low relay, located in the IPDM E/R, and
- to BCM terminal 70
- through 50A fusible link (letter f , located in the fuse and fusible link box).

With the ignition switch in the ON or START position, power is supplied

- to BCM terminal 38
- through 10A fuse (No. 59, located in the fuse and relay box).

Ground is supplied at all times

- to BCM terminal 67
- through body grounds M57, M61 and M79
- to IPDM E/R terminals 38 and 59
- through body grounds E9, E15 and E24.

Low Beam Operation

With the lighting switch in 2ND position, the BCM receives input requesting the headlamps to illuminate. This input is communicated to the IPDM E/R across the CAN communication lines. The central processing unit of the IPDM E/R controls the headlamp low relay coil. When energized, this relay directs power

- to terminal 54 of the IPDM E/R, and
- to terminal 1 of front combination lamp RH
- through 15A fuse (No. 41, located in the IPDM E/R)
- to terminal 52 of the IPDM E/R
- to terminal 1 of front combination lamp LH
- through 15A fuse (No. 40, located in the IPDM E/R).

Ground is supplied at all times

- to terminal 4 of front combination lamp LH and RH
- through body grounds E9, E15 and E24.

With power and ground supplied, low beam headlamps illuminate.

High Beam Operation/Flash-to-Pass Operation

With the lighting switch in 2ND position and placed in HIGH or PASS position, the BCM (body control module) receives input requesting the headlamp high beams to illuminate. This input is communicated to the IPDM E/R (intelligent power distribution module engine room) across the CAN communication lines. The central processing unit of the IPDM E/R controls the headlamp high relay coil. When energized, this relay directs power

- to terminal 56 of the IPDM E/R, and
- to terminal 2 of front combination lamp RH
- through 10A fuse (No. 34, located in the IPDM E/R)
- to terminal 55 of the IPDM E/R
- to terminal 2 of front combination lamp LH
- through 10A fuse (No. 35, located in the IPDM E/R).

Ground is supplied at all times

- to terminal 3 of front combination lamp LH and RH
- through body grounds E9, E15 and E24.

With power and ground supplied, the high beam headlamps and the HIGH BEAM indicator illuminate.

A
B
C
D
E
F
G
H
I
J
LT
L
M

HEADLAMP (FOR USA)

BATTERY SAVER CONTROL

When the combination switch (lighting switch) is in the 2ND position (ON), and the ignition switch is turned from ON or ACC to OFF, the battery saver control feature is activated.

Under this condition, the headlamps remain illuminated for 5 minutes, unless the combination switch (lighting switch) position is changed. If the combination switch (lighting switch) position is changed, then the headlamps are turned off.

AUTO LIGHT OPERATION

Refer to [LT-50, "System Description"](#) for auto light operation.

VEHICLE SECURITY SYSTEM (PANIC ALARM)

The vehicle security system (panic alarm) will flash the high beams if the system is triggered. Refer to [BL-57, "Panic Alarm Operation"](#).

CAN Communication System Description

EKS00736

Refer to [LAN-8, "CAN COMMUNICATION"](#).

HEADLAMP (FOR USA)

Schematic

EKS00737

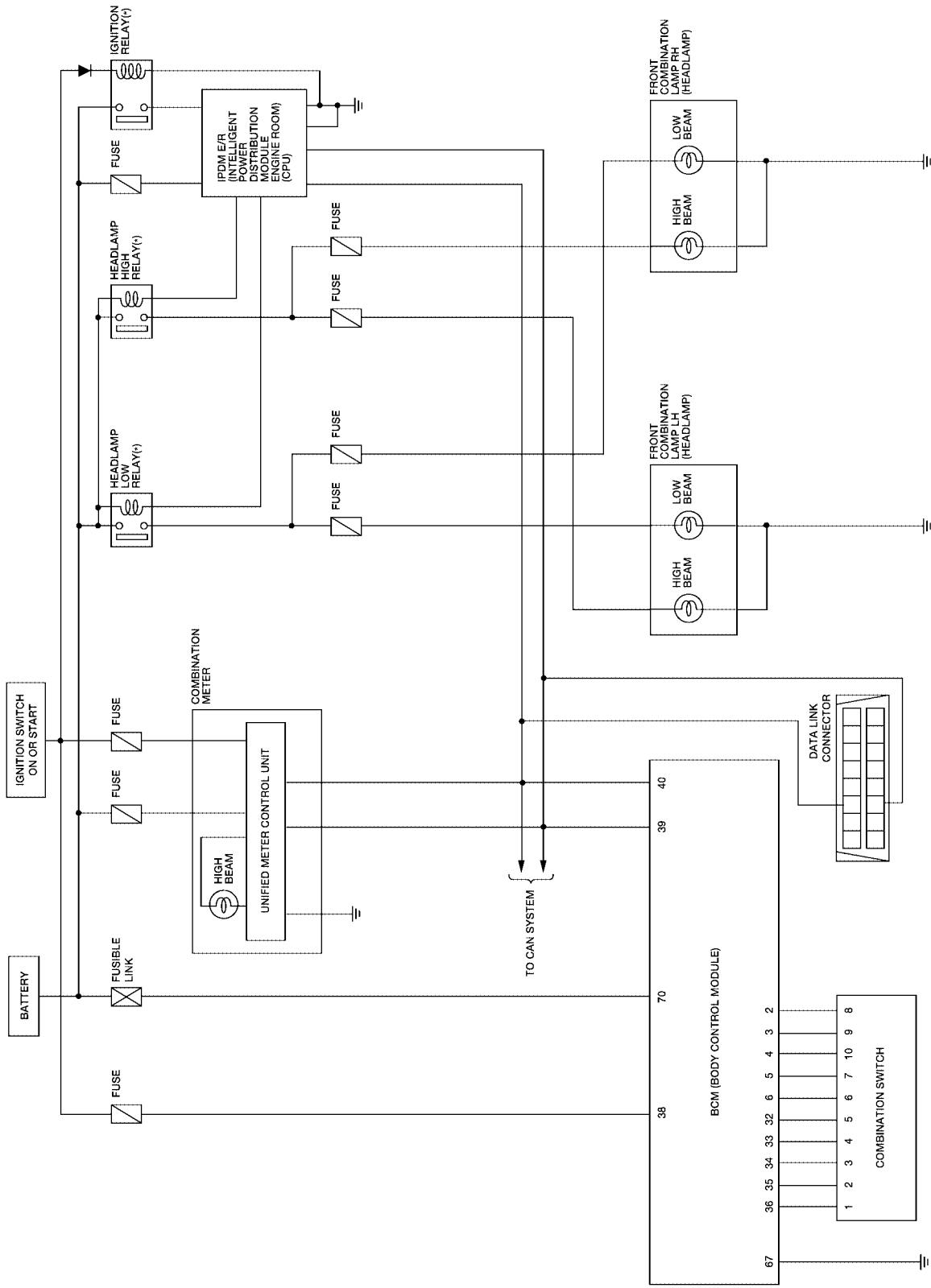

*: THIS RELAY IS BUILT INTO THE IPDM E/R (INTELLIGENT POWER DISTRIBUTION MODULE ENGINE ROOM)

A
B
C
D
E
F
G
H
I
J
LT
L
M

WKWA0721E

HEADLAMP (FOR USA)

Wiring Diagram - H/LAMP -

EKS00738

LT-H/LAMP-01

— : DATA LINE

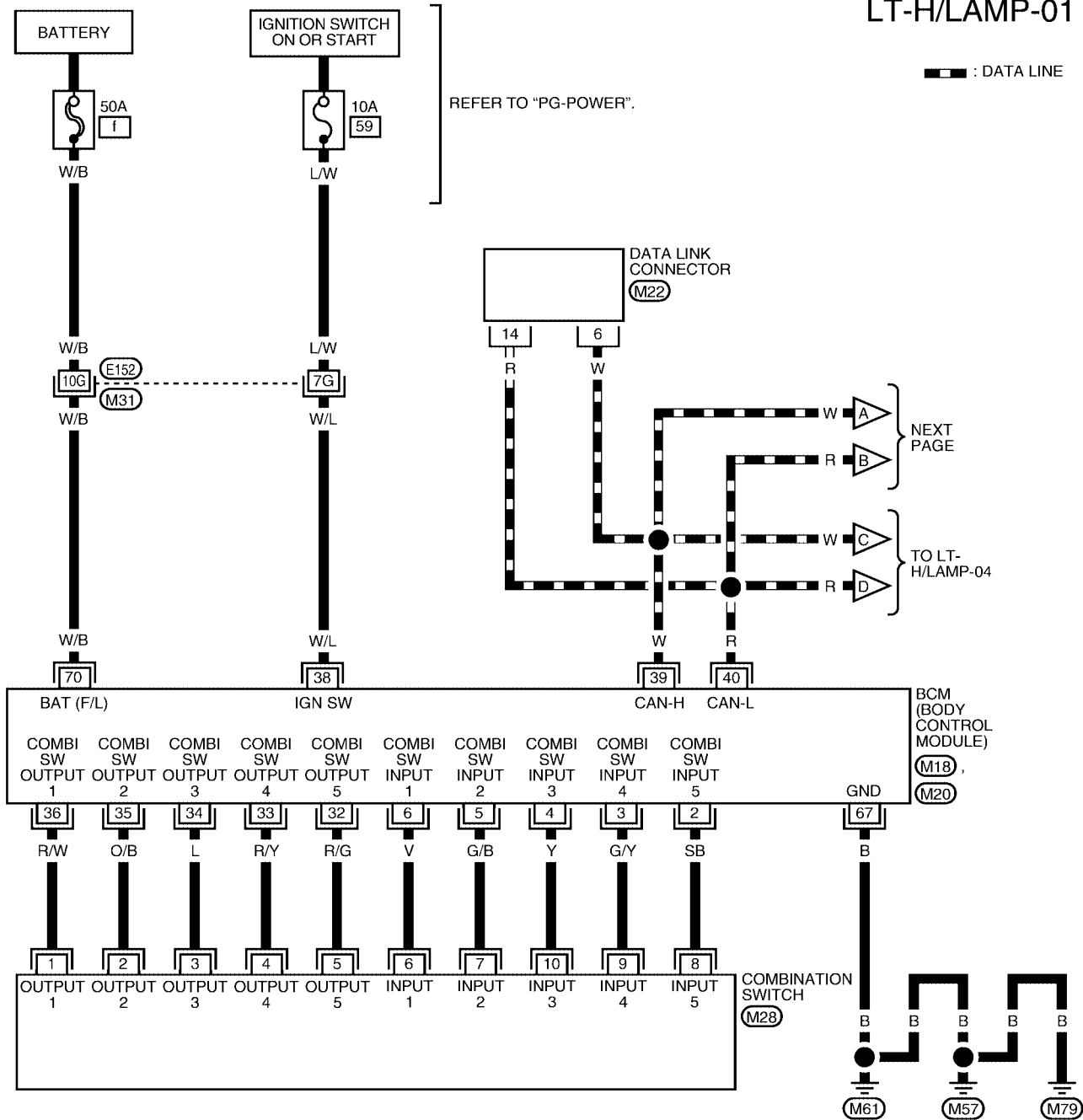

REFER TO "PG-POWER".

NEXT PAGE

TO LT-H/LAMP-04

BCM (BODY CONTROL MODULE)
M18
M20

COMBINATION SWITCH
M28

M61 M57 M79

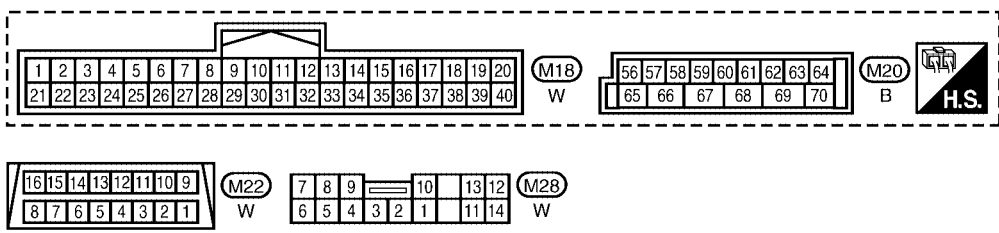

REFER TO THE FOLLOWING.
M31 - SUPER MULTIPLE JUNCTION (SMJ)

WKWA1154E

HEADLAMP (FOR USA)

LT-H/LAMP-02

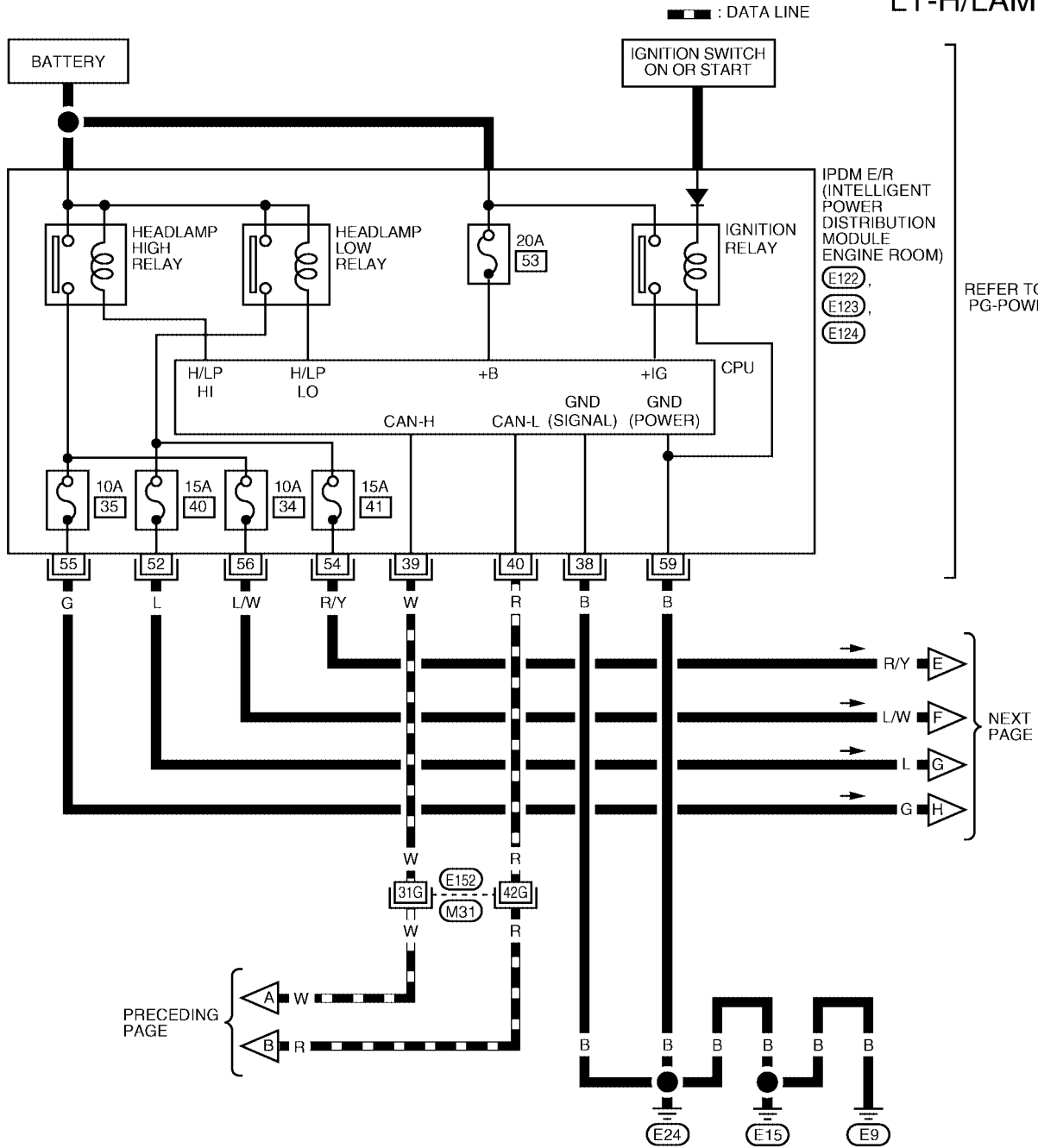

A
B
C
D
E
F
G
H
I
J
LT
L
M

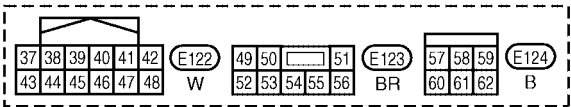

REFER TO THE FOLLOWING.
(M31) - SUPER MULTIPLE JUNCTION (SMJ)

WKWA1193E

HEADLAMP (FOR USA)

LT-H/LAMP-03

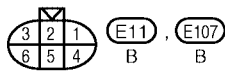
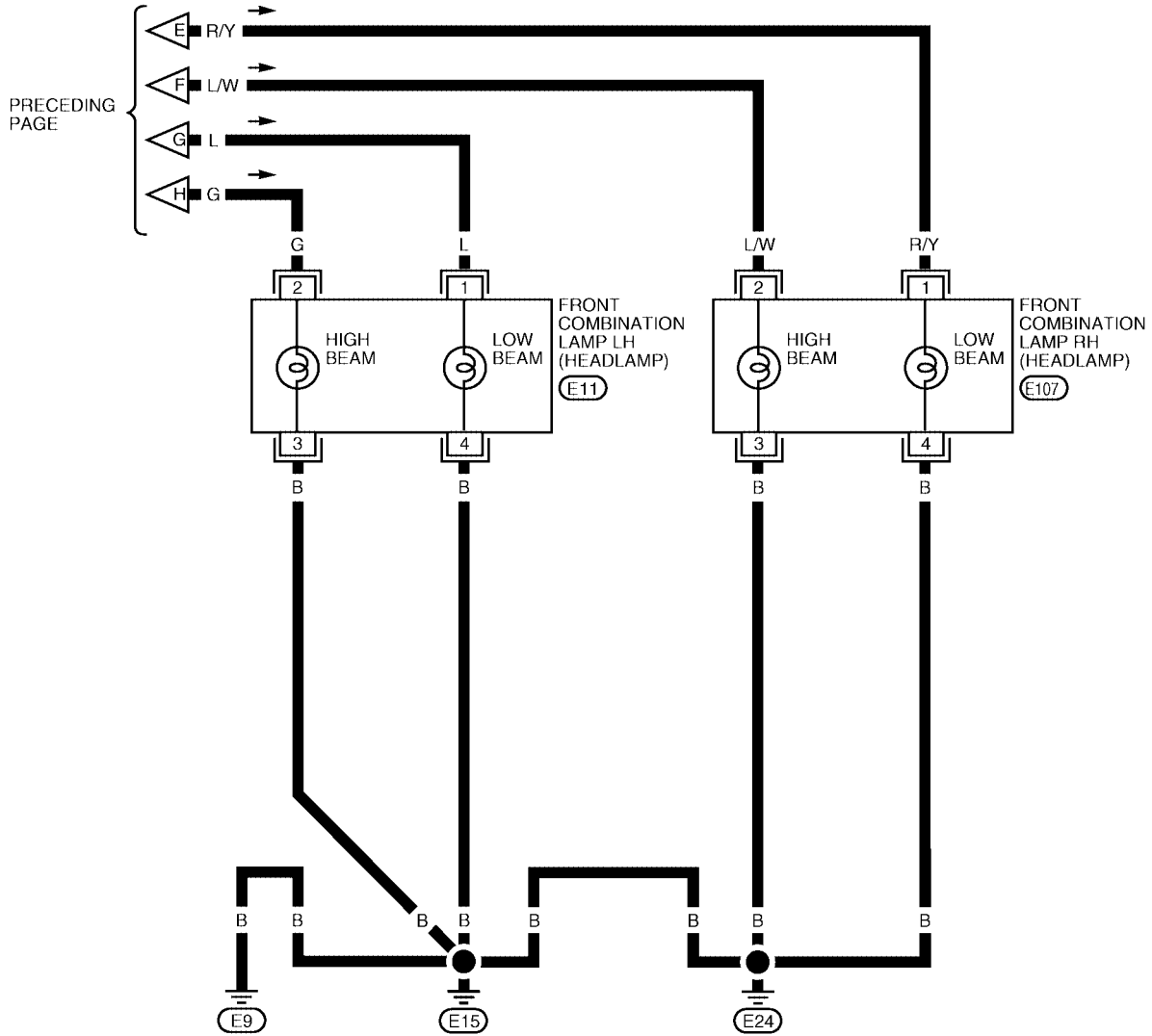

WKWA1475E

HEADLAMP (FOR USA)

LT-H/LAMP-04

▬ : DATA LINE

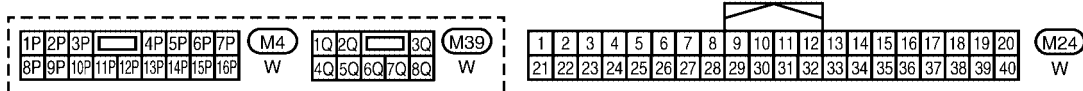
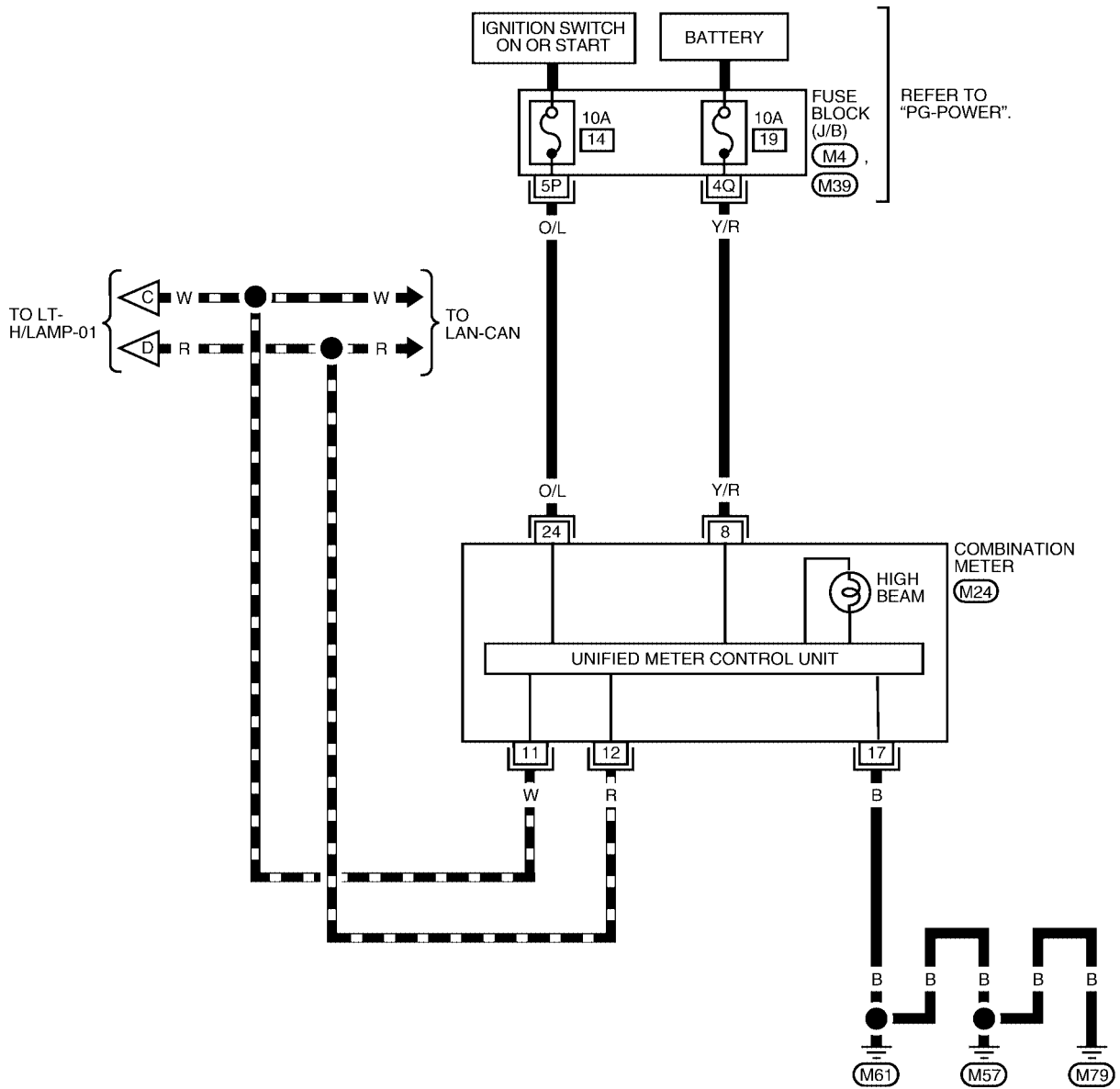





WKWA0725E

HEADLAMP (FOR USA)

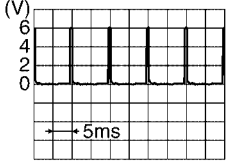
Terminals and Reference Value for BCM

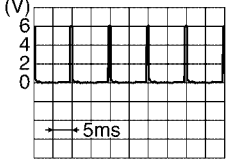
EKS00739

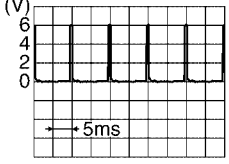
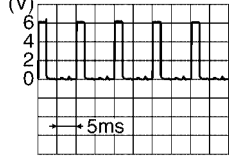
Terminal No.	Wire color	Signal name	Measuring condition		Reference value (Approx.)
			Ignition switch	Operation or condition	
2	SB	Combination switch input 5	ON	Lighting, turn, wiper OFF Wiper dial position 4	 <p style="text-align: right;">SKIA5291E</p>
3	G/Y	Combination switch input 4	ON	Lighting, turn, wiper OFF Wiper dial position 4	 <p style="text-align: right;">SKIA5292E</p>
4	Y	Combination switch input 3	ON	Lighting, turn, wiper OFF Wiper dial position 4	 <p style="text-align: right;">SKIA5291E</p>
5	G/B	Combination switch input 2	ON	Lighting, turn, wiper OFF Wiper dial position 4	 <p style="text-align: right;">SKIA5292E</p>
6	V	Combination switch input 1			
32	R/G	Combination switch output 5	ON	Lighting, turn, wiper OFF Wiper dial position 4	 <p style="text-align: right;">SKIA5291E</p>
33	R/Y	Combination switch output 4	ON	Lighting, turn, wiper OFF Wiper dial position 4	 <p style="text-align: right;">SKIA5292E</p>
34	L	Combination switch output 3	ON	Lighting, turn, wiper OFF Wiper dial position 4	 <p style="text-align: right;">SKIA5291E</p>

HEADLAMP (FOR USA)

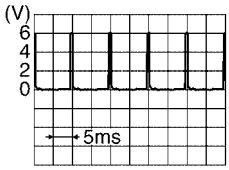
Terminal No.	Wire color	Signal name	Measuring condition		Reference value (Approx.)
			Ignition switch	Operation or condition	
35	O/B	Combination switch output 2	ON	Lighting, turn, wiper OFF Wiper dial position 4	 SKIA5292E
36	R/W	Combination switch output 1			
38	W/L	Ignition switch (ON)	ON	—	Battery voltage
39	W	CAN- H	—	—	—
40	R	CAN- L	—	—	—
67	B	Ground	ON	—	0V
70	W/B	Battery power supply (fusible link)	OFF	—	Battery voltage

Terminals and Reference Values for IPDM E/R

EKS0073A

Terminal No.	Wire color	Signal name	Measuring condition		Reference value (Approx.)	
			Ignition switch	Operation or condition		
38	B	Ground	ON	—	0V	
39	W	CAN- H	—	—	—	
40	R	CAN- L	—	—	—	
52	L	Headlamp low (LH)	ON	Lighting switch 2ND position	OFF	0V
					ON	Battery voltage
54	R/Y	Headlamp low (RH)	ON	Lighting switch 2ND position	OFF	0V
					ON	Battery voltage
55	G	Headlamp high (LH)	ON	Lighting switch HIGH or PASS position	OFF	0V
					ON	Battery voltage
56	LW	Headlamp high (RH)	ON	Lighting switch HIGH or PASS position	OFF	0V
					ON	Battery voltage
59	B	Ground	ON	—	0V	

How to Proceed With Trouble Diagnosis

EKS0073B

1. Confirm the symptom or customer complaint.
2. Understand operation description and function description. Refer to [LT-7, "System Description"](#) .
3. Perform the Preliminary Check. Refer to [LT-16, "Preliminary Check"](#) .
4. Check symptom and repair or replace the cause of malfunction.
5. Does the headlamp operate normally? If YES: GO TO 6. If NO: GO TO 4.
6. INSPECTION END.

HEADLAMP (FOR USA)

EKS0073C

Preliminary Check CHECK BCM CONFIGURATION

1. CHECK BCM CONFIGURATION

Confirm BCM configuration for "H/L BULB" is set to "HID". Refer to [BCS-13, "READ CONFIGURATION PROCEDURE"](#).

OK or NG

OK >> Continue preliminary check. Refer to [LT-16, "CHECK POWER SUPPLY AND GROUND CIRCUIT"](#).

NG >> Change BCM configuration for "H/L BULB" to "HID". Refer to [BCS-16, "WRITE CONFIGURATION PROCEDURE"](#).

CHECK POWER SUPPLY AND GROUND CIRCUIT

1. CHECK FUSES OR FUSIBLE LINK

Check for blown fuses or fusible link.

Unit	Power source	Fuse No.
BCM	Battery	f
	Ignition switch ON or START position	59
IPDM E/R	Battery	34
		35
		40
		41
		53

Refer to [LT-10, "Wiring Diagram - H/LAMP -"](#).

OK or NG

OK >> GO TO 2.

NG >> If fuse is blown, be sure to eliminate cause of malfunction before installing new fuse. Refer to [PG-4, "POWER SUPPLY ROUTING CIRCUIT"](#).

2. CHECK POWER SUPPLY CIRCUIT

1. Disconnect BCM connector.
2. Check voltage between BCM harness connector and ground.

Terminals		Ignition switch position			
(+)		(-)	OFF	ACC	ON
Connector	Terminal (Wire color)				
M18	38 (W/L)	Ground	0V	0V	Battery voltage
M20	70 (W/B)		Battery voltage	Battery voltage	Battery voltage

OK or NG

OK >> GO TO 3.

NG >> Check harness for open between BCM and fuse.

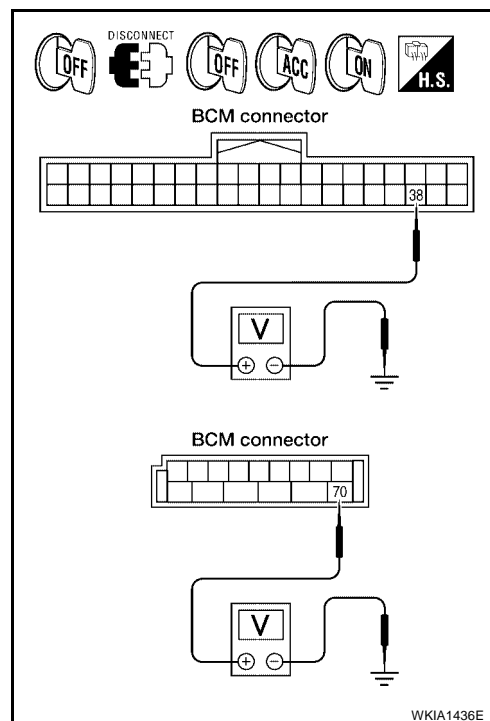

WKIA1436E

HEADLAMP (FOR USA)

3. CHECK GROUND CIRCUIT

Check continuity between BCM harness connector and ground.

Terminals		(-)	Continuity
(+)			
Connector	Terminal (Wire color)		
M20	67 (B)	Ground	Yes

OK or NG

- OK >> INSPECTION END.
- NG >> Check ground circuit harness.

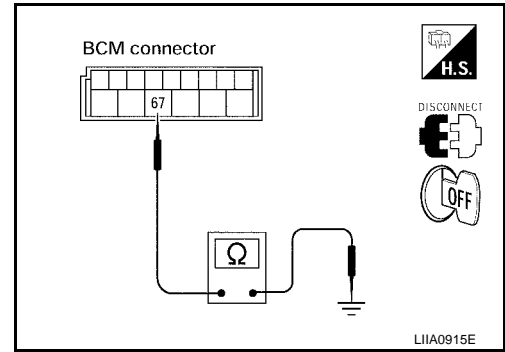

A
B
C
D
E
F
G
H
I
J
LT
L
M

HEADLAMP (FOR USA)

EKS0073D

CONSULT-II Functions (BCM)

CONSULT-II can display each diagnostic item using the diagnostic test modes shown following.

BCM diagnosis part	Check item, diagnosis mode	Description
HEADLAMP	Work support	Changes the setting for each function.
	Data monitor	Displays BCM input data in real time.
	Active test	Operation of electrical loads can be checked by sending drive signal to them.
BCM	Self-diagnosis	BCM performs self-diagnosis of CAN communication.
	CAN DIAG SUPPORT MNTR	The result of transmit/receive diagnosis of CAN communication can be read.

CONSULT-II BASIC OPERATION

CAUTION:

If CONSULT-II is used with no connection of CONSULT-II CONVERTER, malfunctions might be detected in self-diagnosis depending on control unit which carries out CAN communication.

1. With the ignition switch OFF, connect CONSULT-II and CONSULT-II CONVERTER to the data link connector, then turn ignition switch ON.

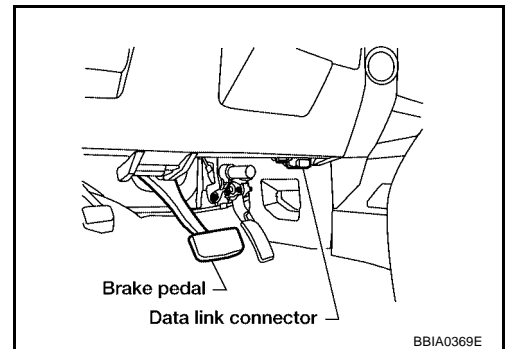

2. Touch "START (NISSAN BASED VHCL)".

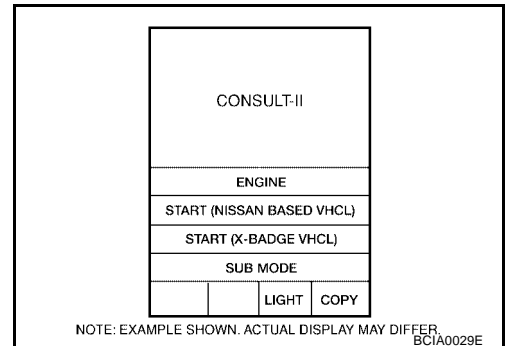

3. Touch "BCM" on "SELECT SYSTEM" screen.
If "BCM" is not indicated, go to [GI-38, "CONSULT-II Data Link Connector \(DLC\) Circuit"](#).

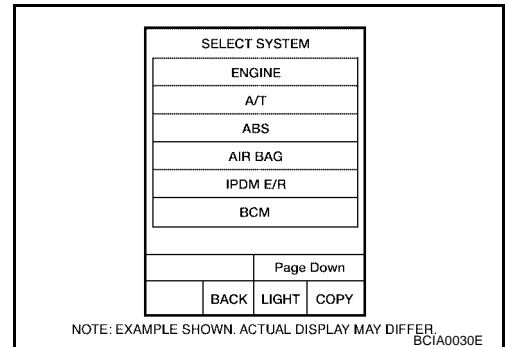

HEADLAMP (FOR USA)

4. Touch "HEADLAMP" on "SELECT TEST ITEM" screen.

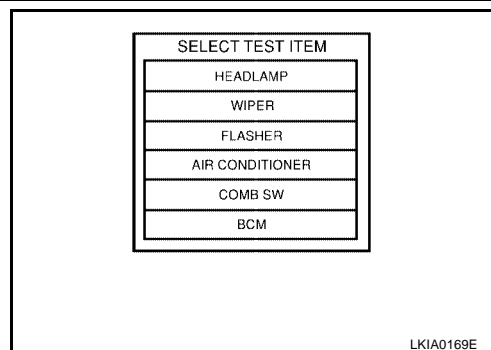

WORK SUPPORT

Operation Procedure

1. Touch "HEADLAMP" on "SELECT TEST ITEM" screen.
2. Touch "WORK SUPPORT" on "SELECT DIAG MODE" screen.
3. Touch item on "SELECT WORK ITEM" screen.
4. Touch "START".
5. Touch "CHANGE SETT".
6. The setting will be changed and "CUSTOMIZING COMPLETED" will be displayed.
7. Touch "END".

Display Item List

Item	Description	CONSULT-II	Factory setting
BATTERY SAVER SET	Exterior lamp battery saver control mode can be changed in this mode. Selects exterior lamp battery saver control mode between ON/OFF.	ON	×
		OFF	—

DATA MONITOR

Operation Procedure

1. Touch "HEADLAMP" on "SELECT TEST ITEM" screen.
2. Touch "DATA MONITOR" on "SELECT DIAG MODE" screen.
3. Touch either "ALL SIGNALS" or "SELECTION FROM MENU" on the "DATA MONITOR" screen.

All signals	Monitors all the signals.
Selection from menu	Selects and monitors individual signal.

4. Touch "START".
5. When "SELECTION FROM MENU" is selected, touch individual items to be monitored. When "ALL SIGNALS" is selected, all the items will be monitored.
6. Touch "RECORD" while monitoring, then the status of the monitored item can be recorded. To stop recording, touch "STOP".

Display Item List

Monitor item	Contents
IGN ON SW "ON/OFF"	Displays "IGN position (ON)/OFF, ACC position (OFF)" judged from the ignition switch signal.
ACC ON SW "ON/OFF"	Displays "ACC (ON)/OFF, Ignition OFF (OFF)" status judged from ignition switch signal.
HI BEAM SW "ON/OFF"	Displays status (high beam switch: ON/Others: OFF) of high beam switch judged from lighting switch signal.
HEAD LAMP SW 1 "ON/OFF"	Displays status (headlamp switch 1: ON/Others: OFF) of headlamp switch 2 judged from lighting switch signal.
HEAD LAMP SW 2 "ON/OFF"	Displays status (headlamp switch 2: ON/Others: OFF) of headlamp switch 2 judged from lighting switch signal.

HEADLAMP (FOR USA)

Monitor item	Contents
TAIL LAMP SW "ON/OFF"	Displays status (lighting switch 1st position: ON/Others: OFF) of lighting switch judged from lighting switch signal.
AUTO LIGHT SW "ON/OFF"	Displays status of the lighting switch as judged from the lighting switch signal. (AUTO position: ON/Other than AUTO position: OFF)
PASSING SW "ON/OFF"	Displays status (flash-to-pass switch: ON/Others: OFF) of flash-to-pass switch judged from lighting switch signal.
FR FOG SW "ON/OFF"	Displays status (front fog lamp switch: ON/Others: OFF) of front fog lamp switch judged from lighting switch signal.
DOOR SW - DR "ON/OFF"	Displays status of the driver door as judged from the driver door switch signal. (Door is open: ON/Door is closed: OFF)
DOOR SW - AS "ON/OFF"	Displays status of the passenger door as judged from the passenger door switch signal. (Door is open: ON/Door is closed: OFF)
DOOR SW - RR "ON/OFF"	Displays status of the rear door as judged from the rear door switch (RH) signal. (Door is open: ON/Door is closed: OFF)
DOOR SW - RL "ON/OFF"	Displays status of the rear door as judged from the rear door switch (LH) signal. (Door is open: ON/Door is closed: OFF)
BACK DOOR SW "ON/OFF"	Not used.
TURN SIGNAL R "ON/OFF"	Displays status (Turn right: ON/Others: OFF) as judged from lighting switch signal.
TURN SIGNAL L "ON/OFF"	Displays status (Turn left: ON/Others: OFF) as judged from lighting switch signal.
CARGO LAMP SW "ON/OFF"	Displays status of cargo lamp switch.
OPTICAL SENSOR [0 - 5V]	Displays "ambient light (close to 5V when dark/close to 0V when light)" judged from optical sensor signal.

ACTIVE TEST

Operation Procedure

1. Touch "HEADLAMP" on "SELECT TEST ITEM" screen.
2. Touch "ACTIVE TEST" on "SELECT DIAG MODE" screen.
3. Touch item to be tested and check operation of the selected item.
4. During the operation check, touching "BACK" deactivates the operation.

Display Item List

Test item	Description
TAIL LAMP	Allows tail lamp relay to operate by switching ON-OFF.
HEAD LAMP (LO)	Allows headlamp relay to operate by switching ON-OFF.
HEAD LAMP (HI)	Allows headlamp relay to operate by switching ON-OFF.
FR FOG LAMP	Allows fog lamp relay to operate by switching ON-OFF.
CARGO LAMP	Allows cargo lamp to operate by switching ON-OFF.
CORNERING LAMP	Not used.

HEADLAMP (FOR USA)

SELF-DIAGNOSTIC RESULTS

Operation Procedure

1. Touch "BCM" on "SELECT TEST ITEM" screen.
2. Touch "SELF-DIAG RESULTS" on "SELECT DIAG MODE" screen.
3. Self-diagnostic results are displayed.

Display Item List

Monitored item	CONSULT-II display	Description
CAN communication	CAN communication [U1000]	Malfunction is detected in CAN communication.
CAN communication system	CAN communication system 1 to 6 [U1000]	Malfunction is detected in CAN system.

CONSULT-II Functions (IPDM E/R)

EKS0073E

CONSULT-II can display each diagnostic item using the diagnostic test modes shown following.

Inspection Item, Diagnosis Mode	Description
DATA MONITOR	The input/output data of the IPDM E/R is displayed in real time.
CAN DIAG SUPPORT MNTR	The result of transmit/receive diagnosis of CAN communication can be read.
ACTIVE TEST	The IPDM E/R sends a drive signal to electronic components to check their operation.

CONSULT-II OPERATION

CAUTION:

If CONSULT-II is used with no connection of CONSULT-II CONVERTER, malfunctions might be detected in self-diagnosis depending on control unit which carries out CAN communication.

1. With the ignition switch OFF, connect CONSULT-II and CONSULT-II CONVERTER to the data link connector, then turn the ignition switch ON.

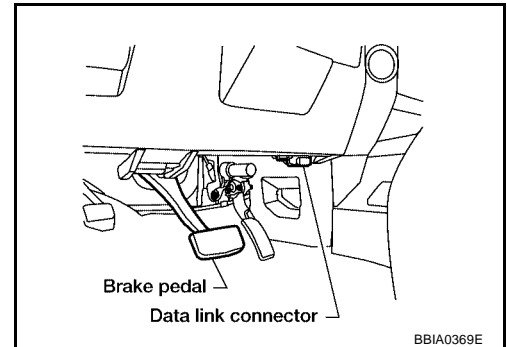

2. Touch "START (NISSAN BASED VHCL)".

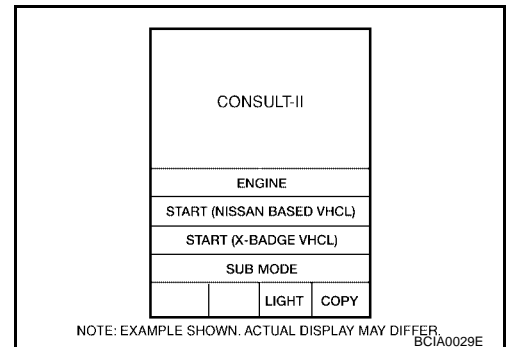

HEADLAMP (FOR USA)

- Touch "IPDM E/R" on "SELECT SYSTEM" screen.
If "IPDM E/R" is not displayed, refer to [GI-38, "CONSULT-II Data Link Connector \(DLC\) Circuit"](#).

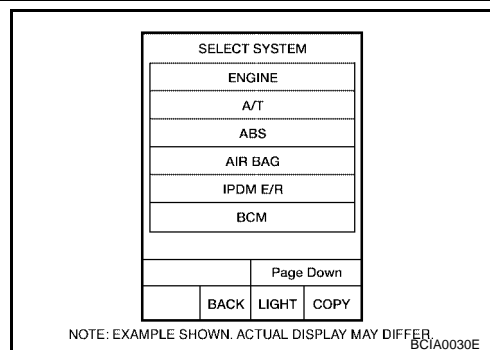

- Select the desired part to be diagnosed on the "SELECT DIAG MODE" screen.

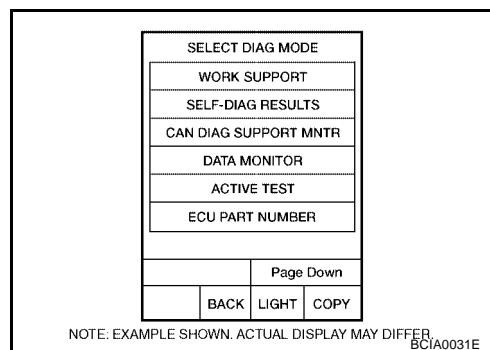

DATA MONITOR

Operation Procedure

- Touch "DATA MONITOR" on "SELECT DIAG MODE" screen.
- Touch "ALL SIGNALS", "MAIN SIGNALS" or "SELECT FROM MENU" on the "DATA MONITOR" screen.

ALL SIGNALS	All items will be monitored.
MAIN SIGNALS	Monitor the predetermined item.
SELECT FROM MENU	Select any item for monitoring.

- Touch "START".
- Touch the required monitoring item on "SELECT ITEM MENU". In "ALL SIGNALS", all items are monitored. In "MAIN SIGNALS", predetermined items are monitored.
- Touch "RECORD" while monitoring to record the status of the item being monitored. To stop recording, touch "STOP".

All Items, Main Items, Select Item Menu

Item name	CONSULT-II screen display	Display or unit	Monitor item selection			Description
			ALL SIGNALS	MAIN SIGNALS	SELECT FROM MENU	
Position lights request	TAIL&CLR REQ	ON/OFF	×	×	×	Signal status input from BCM
Headlamp low beam request	HL LO REQ	ON/OFF	×	×	×	Signal status input from BCM
Headlamp high beam request	HL HI REQ	ON/OFF	×	×	×	Signal status input from BCM
Daytime lights request	DTRL REQ	ON/OFF	×	—	×	Signal status input from BCM
Front fog lights request	FR FOG REQ	ON/OFF	×	×	×	Signal status input from BCM

NOTE:

Perform monitoring of IPDM E/R data with the ignition switch ON. When the ignition switch is at ACC, the display may not be correct.

HEADLAMP (FOR USA)

ACTIVE TEST

Operation Procedure

1. Touch "ACTIVE TEST" on "SELECT DIAG MODE" screen.
2. Touch "EXTERNAL LAMPS" on "SELECT TEST ITEM" screen.
3. Touch item to be tested, and check operation.
4. Touch "START".
5. Touch "STOP" while testing to stop the operation.

Test item	CONSULT-II screen display	Description
Headlamp relay (HI, LO) output	LAMPS	Allows headlamp relay (HI, LO) to operate by switching operation (OFF, HI ON, LO ON) at your option (Head lamp high beam repeats ON-OFF every 1 second).
Front fog lamp relay (FOG) output		Allows fog lamp relay (FOG) to operate by switching operation ON-OFF at your option.
Tail lamp relay output	TAIL LAMP	Allows tail lamp relay to operate by switching operation ON-OFF at your option.
Cornering lamp relay (RH, LH) output	CORNERING LAMP	Allows cornering lamp relay (RH, LH) to operate by switching operation ON-OFF at your option.

Headlamp HI Does Not Illuminate (Both Sides)

EKS0073F

1. CHECK COMBINATION SWITCH INPUT SIGNAL

Select "BCM" on CONSULT-II. With "HEAD LAMP" data monitor, make sure "HI BEAM SW" turns ON-OFF linked with operation of lighting switch.

When lighting switch is in HIGH position : HI BEAM SW ON

OK or NG

OK >> GO TO 2.

NG >> Check lighting switch. Refer to [LT-99, "Combination Switch Inspection"](#).

DATA MONITOR	
MONITOR	
HI BEAM SW	ON

SKIA4193E

2. HEADLAMP ACTIVE TEST

1. Select "IPDM E/R" on CONSULT-II and select "ACTIVE TEST" on "SELECT DIAG MODE" screen.
2. Select "EXTERNAL LAMPS" on "SELECT TEST ITEM" screen.
3. Touch "HI" screen.
4. Make sure headlamp high beam operates.

Headlamp high beam should operate.

OK or NG

OK >> GO TO 3.

NG >> GO TO 4.

ACTIVE TEST			
EXTERNAL LAMPS		OFF	
		TAIL	
LO	HI		
FOG			
MODE	BACK	LIGHT	COPY

WKIA1438E

HEADLAMP (FOR USA)

3. CHECK IPDM E/R

1. Select "IPDM E/R" on CONSULT-II and select "DATA MONITOR" on "SELECT DIAG MODE" screen.
2. Make sure "HL LO REQ" and "HL HI REQ" turns ON when lighting switch is in HI position.

**When lighting switch is in HIGH position : HL LO REQ ON
: HL HI REQ ON**

OK or NG

- OK >> Replace IPDM E/R. Refer to [PG-28, "Removal and Installation of IPDM E/R"](#).
- NG >> Replace BCM. Refer to [BCS-25, "Removal and Installation of BCM"](#).

DATA MONITOR			
MONITOR			
HL LO REQ	ON		
HL HI REQ	ON		
		Page Down	
		RECORD	
MODE	BACK	LIGHT	COPY

SKIA5775E

4. CHECK HEADLAMP INPUT SIGNAL

1. Turn ignition switch OFF.
2. Disconnect front combination RH and LH connector.
3. Select "IPDM E/R" on CONSULT-II and select "ACTIVE TEST" on "SELECT DIAG MODE" screen.
4. Select "EXTERNAL LAMPS" on "SELECT TEST ITEM" screen.
5. Touch "HI" screen.
6. When headlamp high beam is operating, check voltage between front combination RH and LH harness connector and ground.

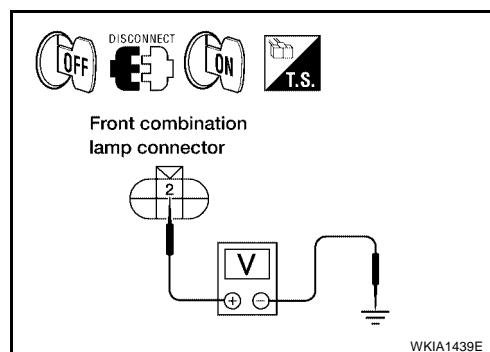

Terminals			Voltage
(+)		(-)	
Connector	Terminal (Wire color)		
RH	E107	2 (L/W)	Ground
LH	E11	2 (G)	
			Battery voltage

OK or NG

- OK >> GO TO 6.
- NG >> GO TO 5.

5. CHECK HEADLAMP CIRCUIT

1. Turn ignition switch OFF.
2. Disconnect IPDM E/R connector.
3. Check continuity between IPDM E/R harness connector E123 terminal 56 (L/W) and front combination RH harness connector E107 terminal 2 (L/W).

56 (L/W) – 2 (L/W) : Continuity should exist.

4. Check continuity between IPDM E/R harness connector E123 terminal 55 (G) and front combination LH harness connector E11 terminal 2 (G).

55 (G) – 2 (G) : Continuity should exist.

OK or NG

- OK >> Replace IPDM E/R. Refer to [PG-28, "Removal and Installation of IPDM E/R"](#).
- NG >> Repair harness or connector.

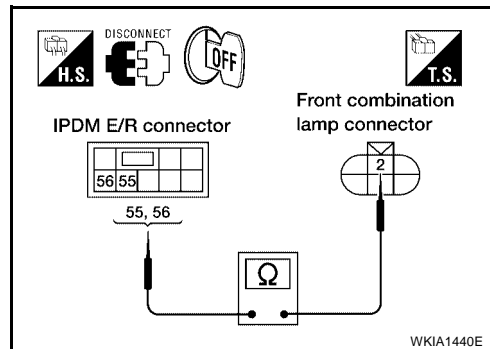

HEADLAMP (FOR USA)

6. CHECK HEADLAMP GROUND

1. Check continuity between front combination RH harness connector E107 terminal 3 (B) and ground.

3 (B) – Ground : Continuity should exist.

2. Check continuity between front combination LH harness connector E11 terminal 3 (B) and ground.

3 (B) – Ground : Continuity should exist.

OK or NG

- OK >> Check front combination connector for damage or poor connection. Repair as necessary.
 NG >> Repair harness or connector.

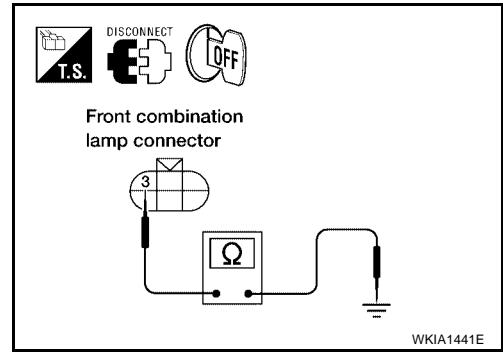

Headlamp HI Does Not Illuminate (One Side)

EKS0073G

1. BULB INSPECTION

Inspect inoperative headlamp bulb.

OK or NG

- OK >> GO TO 2.
 NG >> Replace headlamp bulb. Refer to [LT-32, "HEADLAMP \(INNER SIDE\), FOR HIGH BEAM"](#).

2. CHECK POWER TO HEADLAMP

1. Disconnect inoperative headlamp connector.
2. Turn the high beam headlamps ON.
3. Check voltage between inoperative headlamp terminal and ground.

Terminals			(-)	Voltage (Approx.)
(+)		Terminal (Wire color)		
Connector				Ground
RH	E107	2 (L/W)		
LH	E11	2 (G)		

OK or NG

- OK >> GO TO 3.
 NG >> GO TO 4.

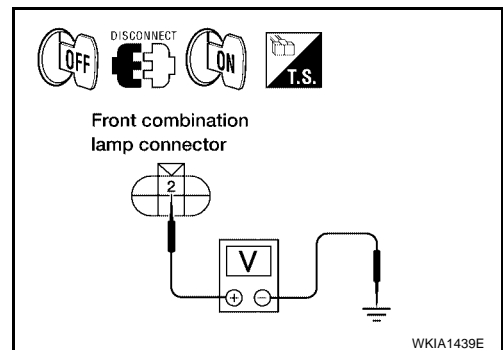

HEADLAMP (FOR USA)

3. CHECK HEADLAMP GROUND

1. Turn the high beam headlamps OFF.
2. Check continuity between inoperative headlamp connector and ground.

Terminals				Continuity
(+)		(-)		
Connector	Terminal (Wire color)			
RH	E107	3 (B)		Yes
LH	E11	3 (B)		

OK or NG

- OK >> Check headlamp connector for damage or poor connection. Repair as necessary.
- NG >> Repair open circuit in harness between inoperative headlamp and ground.

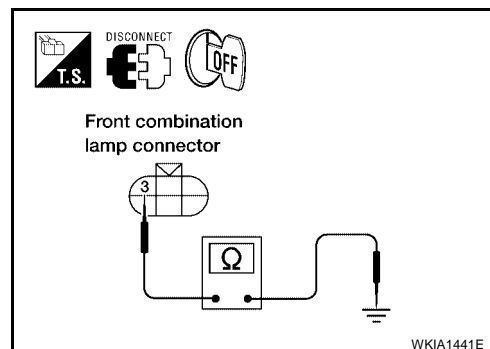

4. INSPECTION BETWEEN IPDM E/R AND HEADLAMPS

1. Disconnect IPDM E/R connector and headlamp connector.
2. Check continuity between harness connector terminals of IPDM E/R and harness connector terminals of inoperative headlamp.

Terminals					Continuity
IPDM E/R		Headlamp			
Connector	Terminal (wire color)	Connector	Terminal (wire color)		
E123	56 (L/W)	Right	E107	2 (L/W)	Yes
	55 (G)	Left	E11	2 (G)	

OK or NG

- OK >> Replace IPDM E/R. Refer to [PG-28, "Removal and Installation of IPDM E/R"](#).
- NG >> Check for short circuits and open circuits in harness between IPDM E/R and headlamps. Repair as necessary.

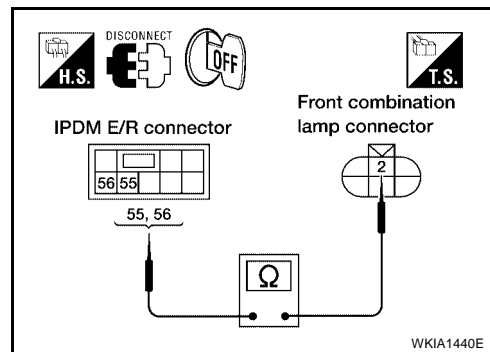

High Beam Indicator Lamp Does Not Illuminate

EKS0073H

1. BULB INSPECTION

Inspect CAN communication system. Refer to [LAN-8, "CAN COMMUNICATION"](#).

OK or NG

- OK >> Replace combination meter. Refer to [IP-13, "COMBINATION METER"](#).
- NG >> Repair as necessary.

HEADLAMP (FOR USA)

EKS0073I

Headlamp LO Does Not Illuminate (Both Sides)

1. CHECK COMBINATION SWITCH INPUT SIGNAL

Select "BCM" on CONSULT-II. With "HEAD LAMP" data monitor, make sure "HEAD LAMP SW1" and "HEAD LAMP SW2" turns ON-OFF linked with operation of lighting switch.

**When lighting switch is in 2ND position : HEAD LAMP SW1 ON
: HEAD LAMP SW2 ON**

OK or NG

OK >> GO TO 2.

NG >> Check lighting switch. Refer to [LT-99, "Combination Switch Inspection"](#).

DATA MONITOR	
MONITOR	
HEAD LAMP SW1	ON
HEAD LAMP SW2	ON

SKIA4194E

2. HEADLAMP ACTIVE TEST

1. Select "IPDM E/R" on CONSULT-II and select "ACTIVE TEST" on "SELECT DIAG MODE" screen.
2. Select "EXTERNAL LAMPS" on "SELECT TEST ITEM" screen.
3. Touch "LO" screen.
4. Make sure headlamp low beam operates.

Headlamp low beam should operate.

OK or NG

OK >> GO TO 3.

NG >> GO TO 4.

ACTIVE TEST			
EXTERNAL LAMPS		OFF	
		TAIL	
LO		HI	
FOG			
MODE	BACK	LIGHT	COPY

WKIA1438E

3. CHECK IPDM E/R

1. Select "IPDM E/R" on CONSULT-II and select "DATA MONITOR" on "SELECT DIAG MODE" screen.
2. Make sure "HL LO REQ" turns ON when lighting switch is in 2ND position.

When lighting switch is in 2ND position : HL LO REQ ON

OK or NG

OK >> Replace IPDM E/R. Refer to [PG-28, "Removal and Installation of IPDM E/R"](#).

NG >> Replace BCM. Refer to [BCS-25, "Removal and Installation of BCM"](#).

DATA MONITOR			
MONITOR			
HL LO REQ	ON		
		Page Down	
RECORD			
MODE	BACK	LIGHT	COPY

SKIA5780E

A
B
C
D
E
F
G
H
I
J
LT
L
M

HEADLAMP (FOR USA)

4. CHECK HEADLAMP INPUT SIGNAL

1. Turn ignition switch OFF.
2. Disconnect front combination RH and LH connector.
3. Select "IPDM E/R" on CONSULT-II and select "ACTIVE TEST" on "SELECT DIAG MODE" screen.
4. Select "EXTERNAL LAMPS" on "SELECT TEST ITEM" screen.
5. Touch "LO" screen.
6. When headlamp low beam is operating, check voltage between front combination RH and LH harness connector and ground.

Terminals			(-)	Voltage
(+) Connector		Terminal (Wire color)		
RH	E107	1 (R/Y)	Ground	Battery voltage
LH	E11	1 (L)		

OK or NG

- OK >> GO TO 6.
 NG >> GO TO 5.

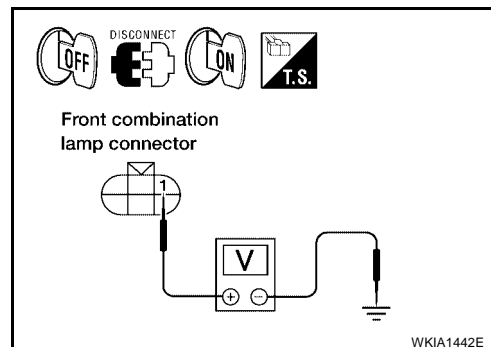

5. CHECK HEADLAMP CIRCUIT

1. Turn ignition switch OFF.
2. Disconnect IPDM E/R connector.
3. Check continuity between IPDM E/R harness connector E123 terminal 54 (R/Y) and front combination lamp RH harness connector E107 terminal 1 (R/Y).

54 (R/Y) – 1 (R/Y) : Continuity should exist.

4. Check continuity between IPDM E/R harness connector E123 terminal 52 (L) and front combination lamp LH harness connector E11 terminal 1 (L).

52 (L) – 1 (L) : Continuity should exist.

OK or NG

- OK >> Replace IPDM E/R. Refer to [PG-28, "Removal and Installation of IPDM E/R"](#) .
 NG >> Repair harness or connector.

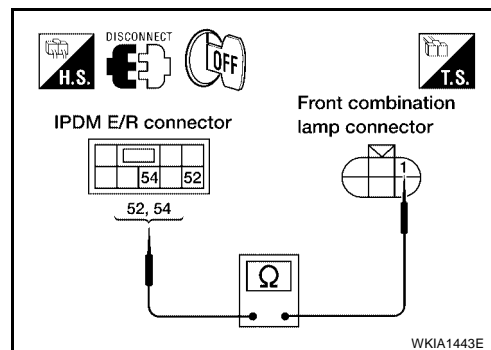

6. CHECK HEADLAMP GROUND

1. Turn ignition switch OFF.
2. Check continuity between front combination lamp RH harness connector E107 terminal 4 (B) and ground.

4 (B) – Ground : Continuity should exist.

3. Check continuity between front combination lamp LH harness connector E11 terminal 4 (B) and ground.

4 (B) – Ground : Continuity should exist.

OK or NG

- OK >> Check front combination lamp connector for damage or poor connection. Repair as necessary.
 NG >> Repair harness or connector.

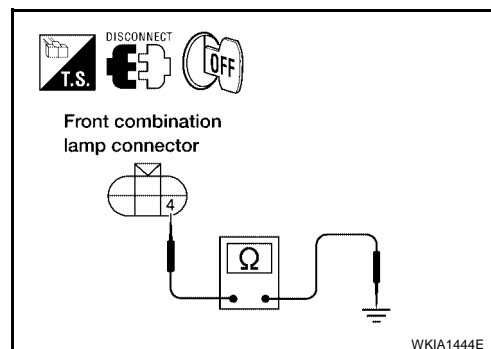

HEADLAMP (FOR USA)

EKS0073J

Headlamp LO Does Not Illuminate (One Side)

1. BULB INSPECTION

Inspect inoperative headlamp bulb.

OK or NG

OK >> GO TO 2.

NG >> Replace headlamp bulb. Refer to [LT-32, "HEADLAMP \(OUTER SIDE\), FOR LOW BEAM"](#) .

2. CHECK POWER TO HEADLAMP

1. Disconnect inoperative headlamp connector.
2. Turn the low beam headlamps ON.
3. Check voltage between inoperative headlamp connector terminal and ground.

Terminals			Voltage (Approx.)
(+)		(-)	
Connector	Terminal		
Right	E107	1 (R/Y)	Ground
Left	E11	1 (L)	
			Battery voltage

OK or NG

OK >> GO TO 3.

NG >> GO TO 4.

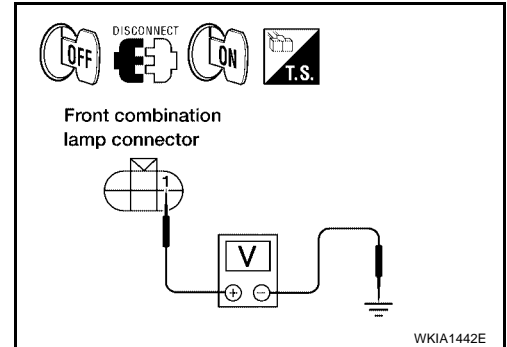

3. CHECK HEADLAMP GROUND

1. Turn the low beam headlamps OFF.
2. Check continuity between inoperative headlamp connector terminal and ground.

Terminals			Continuity
(+)		(-)	
Connector	Terminal (Wire color)		
RH	E107	4 (B)	Ground
LH	E11	4 (B)	
			Yes

OK or NG

OK >> Check headlamp and IPDM E/R connector. Repair as necessary.

NG >> Repair open circuit in harness between inoperative headlamp and ground.

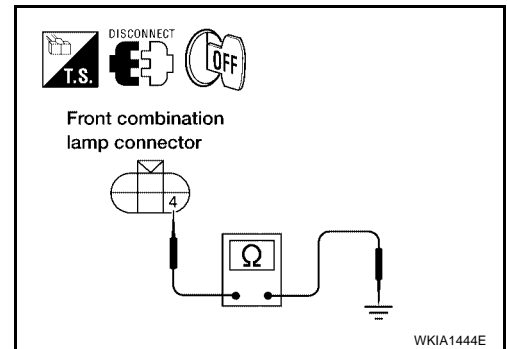

HEADLAMP (FOR USA)

4. INSPECTION BETWEEN IPDM E/R AND HEADLAMPS

1. Disconnect IPDM E/R connector.
2. Check continuity between harness connector terminals of IPDM E/R and harness connector terminals of inoperative headlamp.

Terminals					Continuity
IPDM E/R		Front combination lamp			
Connector	Terminal (Wire color)	Connector	Terminal (Wire color)		
E123	54 (R/Y)	RH	E107	1 (R/Y)	Yes
	52 (L)	LH	E11	1 (L)	

OK or NG

OK >> Replace IPDM E/R. Refer to [PG-28, "Removal and Installation of IPDM E/R"](#) .

NG >> Check for short circuits and open circuits in harness between IPDM E/R and headlamps. Repair as necessary.

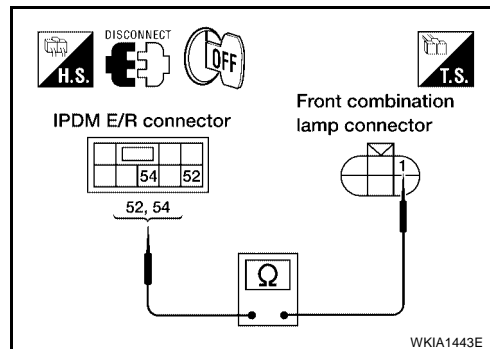

Headlamps Do Not Turn OFF

EKS0073K

1. CHECK COMBINATION SWITCH INPUT SIGNAL

Select "BCM" on CONSULT-II. With "HEAD LAMP" data monitor, make sure "HEAD LAMP SW 1" and "HEAD LAMP SW 2" turns ON-OFF linked with operation of lighting switch.

When lighting switch is OFF : HEAD LAMP SW 1 OFF position
: HEAD LAMP SW 2 OFF

OK or NG

OK >> Replace IPDM E/R. Refer to [PG-28, "Removal and Installation of IPDM E/R"](#) .

NG >> GO TO 2.

DATA MONITOR	
MONITOR	
HEAD LAMP SW 1	OFF
HEAD LAMP SW 2	OFF

SKIA5200E

2. CHECK LIGHTING SWITCH

Check lighting switch. Refer to [LT-99, "Combination Switch Inspection"](#) .

OK or NG

OK >> GO TO 3.

NG >> Replace switch. Refer to [LT-101, "Removal and Installation"](#) .

3. CHECKING CAN COMMUNICATIONS BETWEEN BCM AND IPDM E/R

Select "BCM" on CONSULT-II, and perform self-diagnosis for "BCM".

Display of self-diagnosis results

NO DTC>> Replace IPDM E/R.

CAN COMM CIRCUIT>> Refer to [BCS-13, "CAN Communication Inspection Using CONSULT-II \(Self-Diagnosis\)"](#) .

SELF-DIAG RESULTS			
DTC RESULTS		TIME	
CAN COMM CIRCUIT [U1000]		PAST	
ERASE		PRINT	
MODE	BACK	LIGHT	COPY

SKIA1039E

HEADLAMP (FOR USA)

Aiming Adjustment

EKS0073L

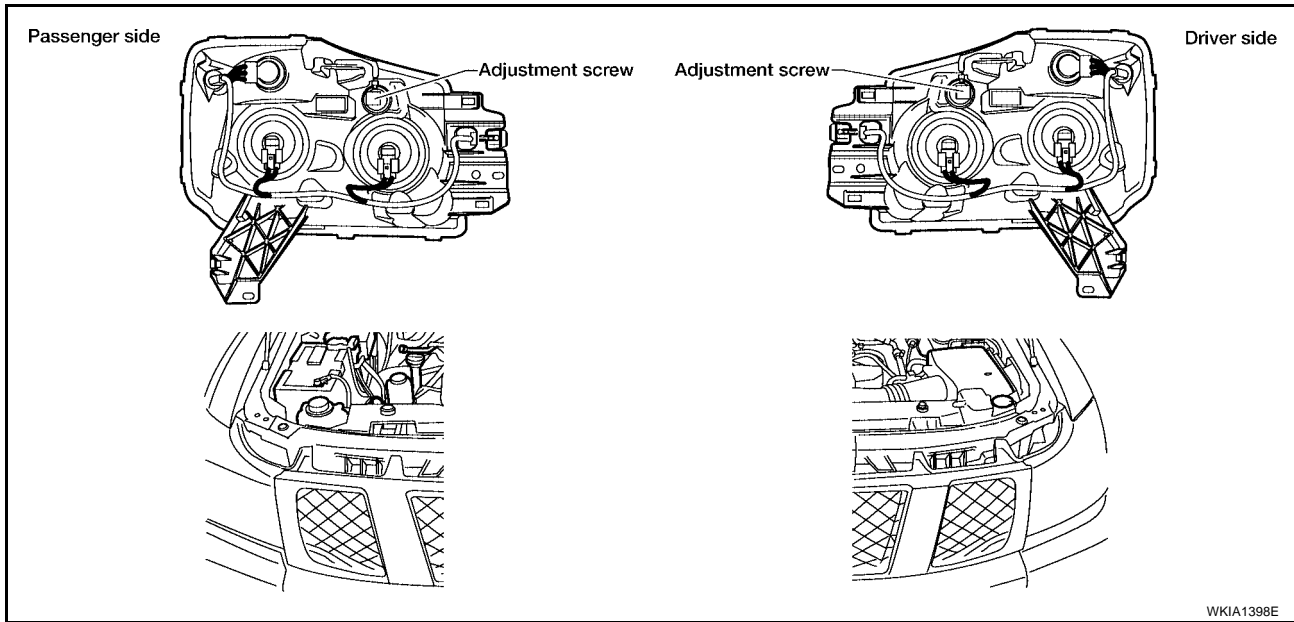

For details, refer to the regulations in your state.

Before performing aiming adjustment, check the following.

1. Ensure all tires are inflated to correct pressure.
2. Place vehicle and screen on level surface.
3. Ensure there is no load in vehicle other than the driver (or equivalent weight placed in driver's position). Coolant and engine oil filled to correct level, and fuel tank full.
4. Confirm spare tire, jack and tools are properly stowed.

LOW BEAM AND HIGH BEAM

NOTE:

Aim each headlamp individually and ensure other headlamp beam pattern is blocked from screen.

1. Turn headlamp low beam on.
2. Use adjusting screw to perform aiming adjustment.

A
B
C
D
E
F
G
H
I
J
LT
L
M

HEADLAMP (FOR USA)

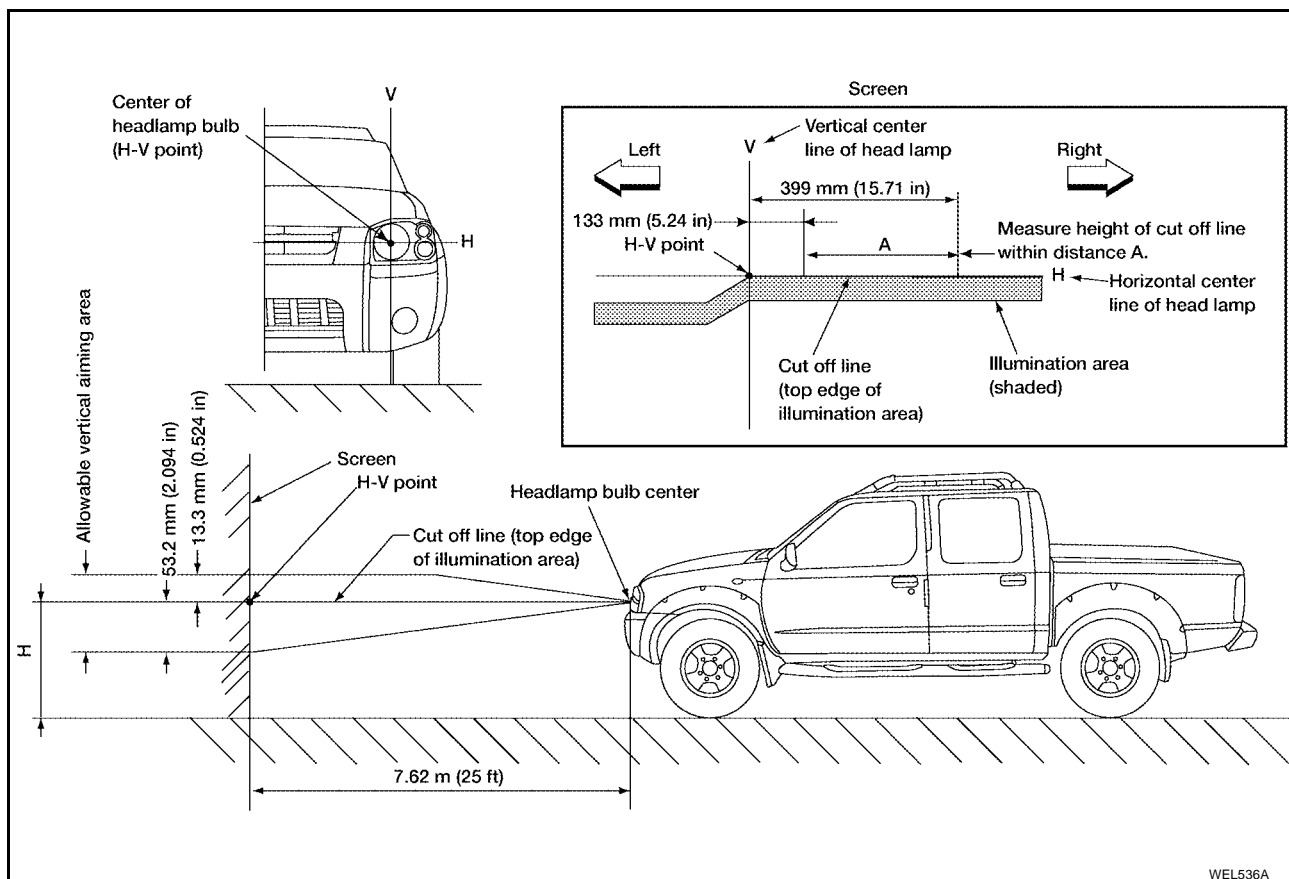

WEL536A

If the vehicle front body has been repaired and/or the headlamp assembly has been replaced, check aiming. Use the aiming chart shown in the figure.

- **Basic illuminating area for adjustment should be within the range shown on the aiming chart. Adjust headlamps accordingly.**

Bulb Replacement HEADLAMP (OUTER SIDE), FOR LOW BEAM

EKS0073M

NOTE:

Reach through wheel opening for access.

1. Turn headlamp switch OFF.
2. Disconnect the electrical connector.
3. Turn the bulb counterclockwise to remove it.
4. Installation is in the reverse order of removal.

HEADLAMP (INNER SIDE), FOR HIGH BEAM

1. Turn headlamp switch OFF.
2. Disconnect the electrical connector.
3. Turn the bulb counterclockwise to remove it.
4. Installation is in the reverse order of removal.

FRONT TURN SIGNAL/PARKING LAMP

NOTE:

Reach through wheel opening for access.

1. Turn the bulb socket counterclockwise to unlock it.
2. Pull the bulb to remove it from the socket.
3. Installation is in the reverse order of removal.

FRONT SIDE MARKER LAMP

NOTE:

Reach through wheel opening for access.

HEADLAMP (FOR USA)

1. Turn the bulb socket counterclockwise to unlock it.
2. Pull the bulb to remove it from the socket.
3. Installation is in the reverse order of removal.

CAUTION:

After installing the bulb, be sure to install the bulb socket securely to ensure watertightness.

A

B

C

D

E

F

G

H

I

J

LT

L

M

HEADLAMP (FOR USA)

EKS0073N

Removal and Installation

REMOVAL

1. Remove the grille. Refer to [EI-20, "Removal and Installation"](#) .
2. Remove the front bumper filler panel.
3. Disconnect the connector.
4. Remove the 4 headlamp mounting bolts.

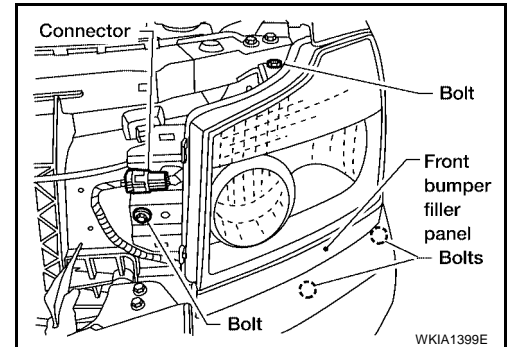

INSTALLATION

Installation is in the reverse order of removal.

: **6.0 N·m (0.61 kg-m, 53 in-lb)**

HEADLAMP (FOR USA)

Disassembly and Assembly DISASSEMBLY

EKS00730

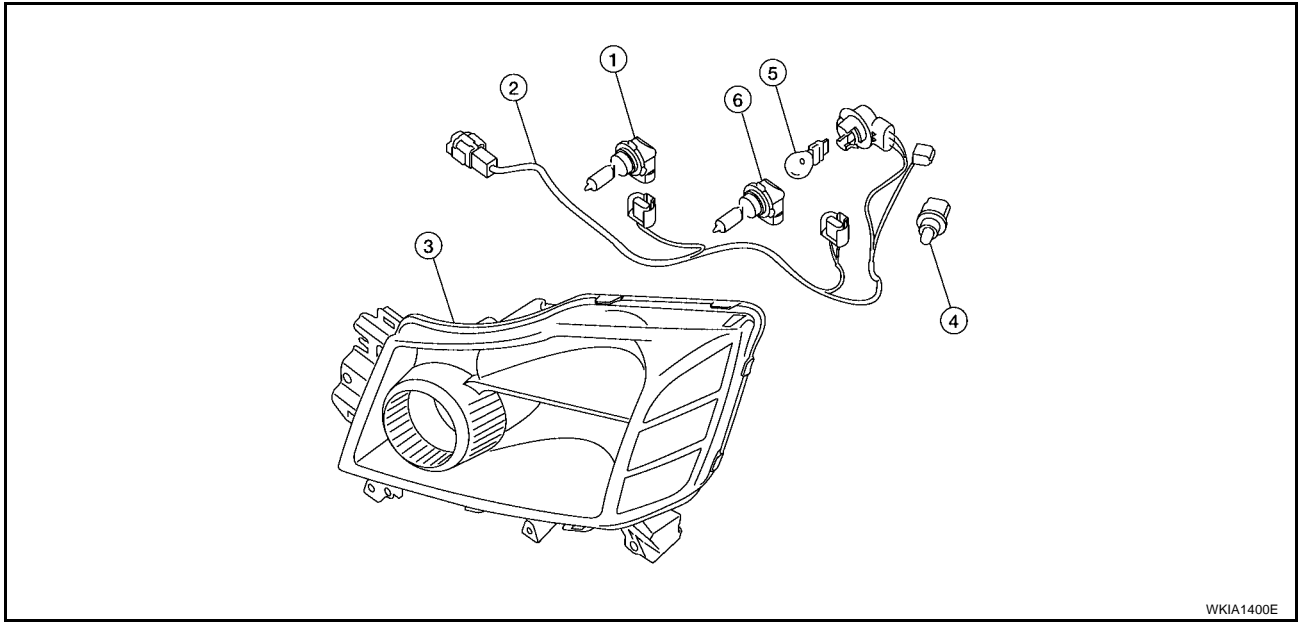

- | | | |
|------------------------------|----------------------------------|-----------------------------|
| 1. Headlamp bulb (High beam) | 2. Wiring harness assembly | 3. Headlamp assembly |
| 4. Side marker lamp bulb | 5. Parking/turn signal lamp bulb | 6. Headlamp bulb (Low beam) |

WKIA1400E

A
B
C
D
E
F
G
H
I
J
LT
L
M

HEADLAMP (FOR CANADA) - DAYTIME LIGHT SYSTEM -

HEADLAMP (FOR CANADA) - DAYTIME LIGHT SYSTEM - Component Parts and Harness Connector Location

PF2:26010

EKS0073P

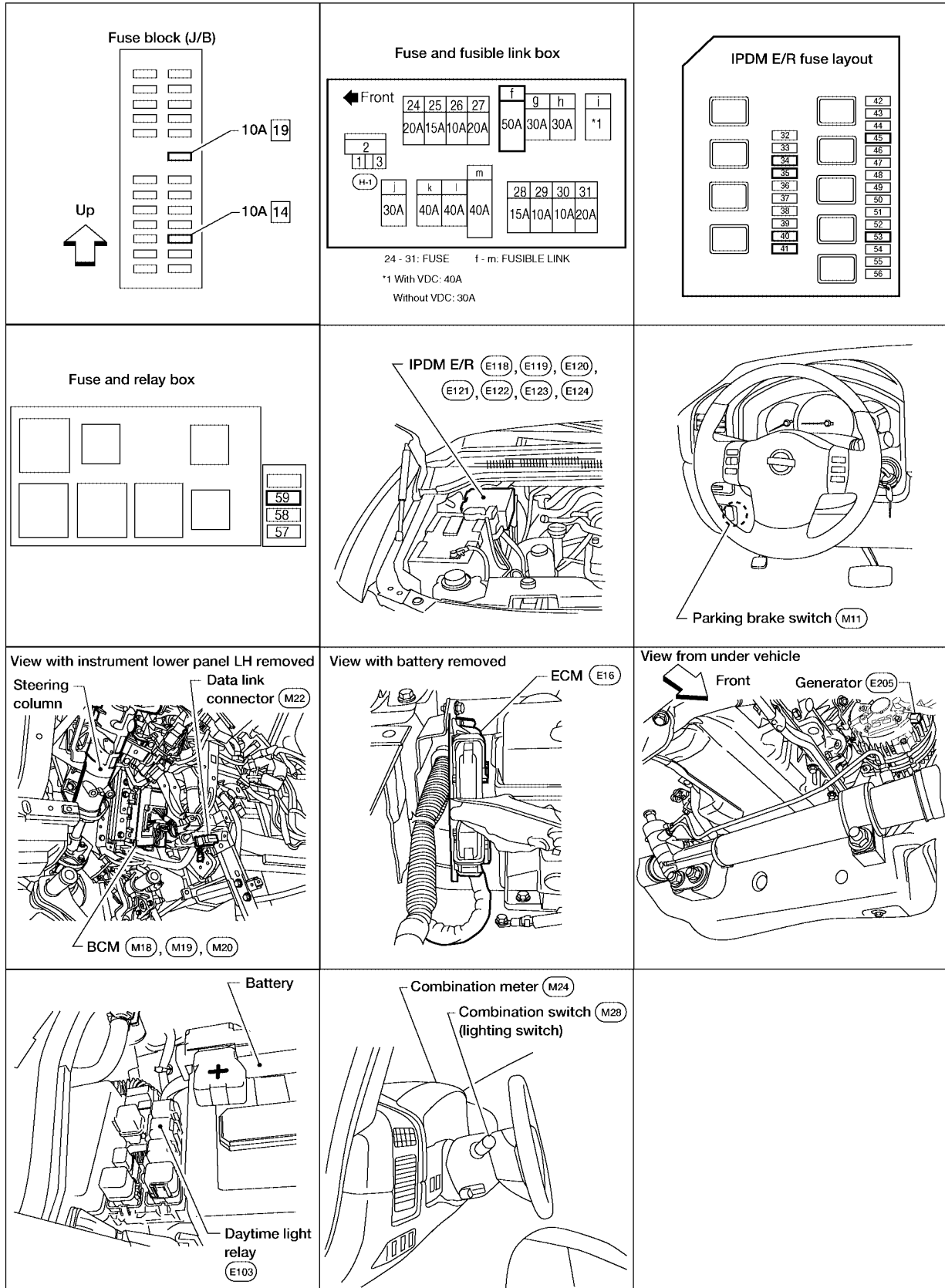

WKIA2831E

HEADLAMP (FOR CANADA) - DAYTIME LIGHT SYSTEM -

System Description

EKS0073Q

DAYTIME LIGHT SYSTEM turns on daytime light lamps while driving. Daytime light lamps are not turned on if engine is activated with parking brake on. Take off parking brake to turn on daytime light lamps. The lamps turn off when lighting switch is in the 2ND position or AUTO position (Head lamp is "ON") and when lighting switch is in the PASSING position. (Daytime light lamps are not turned off only by parking brake itself.)

A parking brake signal and engine run or stop signal are sent to BCM (body control module) by CAN communication line, and control daytime light system.

OUTLINE

Power is supplied at all times

- to combination meter terminal 8
- through 10A fuse [No. 19, located in the fuse block (J/B)]
- to BCM terminal 70
- through 50A fusible link (letter f , located in the fuse and fusible link box)
- to daytime light relay terminals 2 and 5
- through 10A fuse [No. 45, located in the IPDM E/R (intelligent power distribution module engine room)].

When the ignition switch is in ON or START position, power is supplied

- to combination meter terminal 24
- through 10A fuse [No. 14, located in the fuse block (J/B)]
- to BCM terminal 38
- through 10A fuse (No. 59, located in the fuse and relay box).

Ground is supplied

- to combination meter terminals 17 and
- to BCM terminal 67
- through grounds M57, M61 and M79.

DAYTIME LIGHT OPERATION

With the engine running, the lighting switch in the OFF or 1ST position and parking brake released, the IPDM E/R receives input requesting the daytime lights illuminate. This input is communicated across the CAN communication lines. The central processing unit of the IPDM E/R controls the daytime light relay coil. When energized, this relay directs power

- through daytime light relay terminal 3
- through front combination lamp LH terminal 3
- through front combination lamp LH terminal 2
- through IPDM E/R terminal 55
- through 10A fuse (No. 35, located in the IPDM E/R)
- through 10A fuse (No. 34, located in the IPDM E/R)
- through IPDM E/R terminal 56
- to front combination lamp RH terminal 2.

Ground is supplied

- to combination lamp RH terminal 3
- through grounds E9, E15 and E24.

With power and grounds supplied, the daytime lights illuminate. The high beam headlamps are now wired in series and illuminate at a reduced intensity.

COMBINATION SWITCH READING FUNCTION

Refer to [LT-97, "Combination Switch Reading Function"](#) .

AUTO LIGHT OPERATION

For auto light operation, refer to [LT-50, "System Description"](#) in "AUTO LIGHT SYSTEM".

CAN Communication System Description

EKS0073R

Refer to [LAN-8, "CAN COMMUNICATION"](#) .

HEADLAMP (FOR CANADA) - DAYTIME LIGHT SYSTEM -

Schematic

EKS0073S

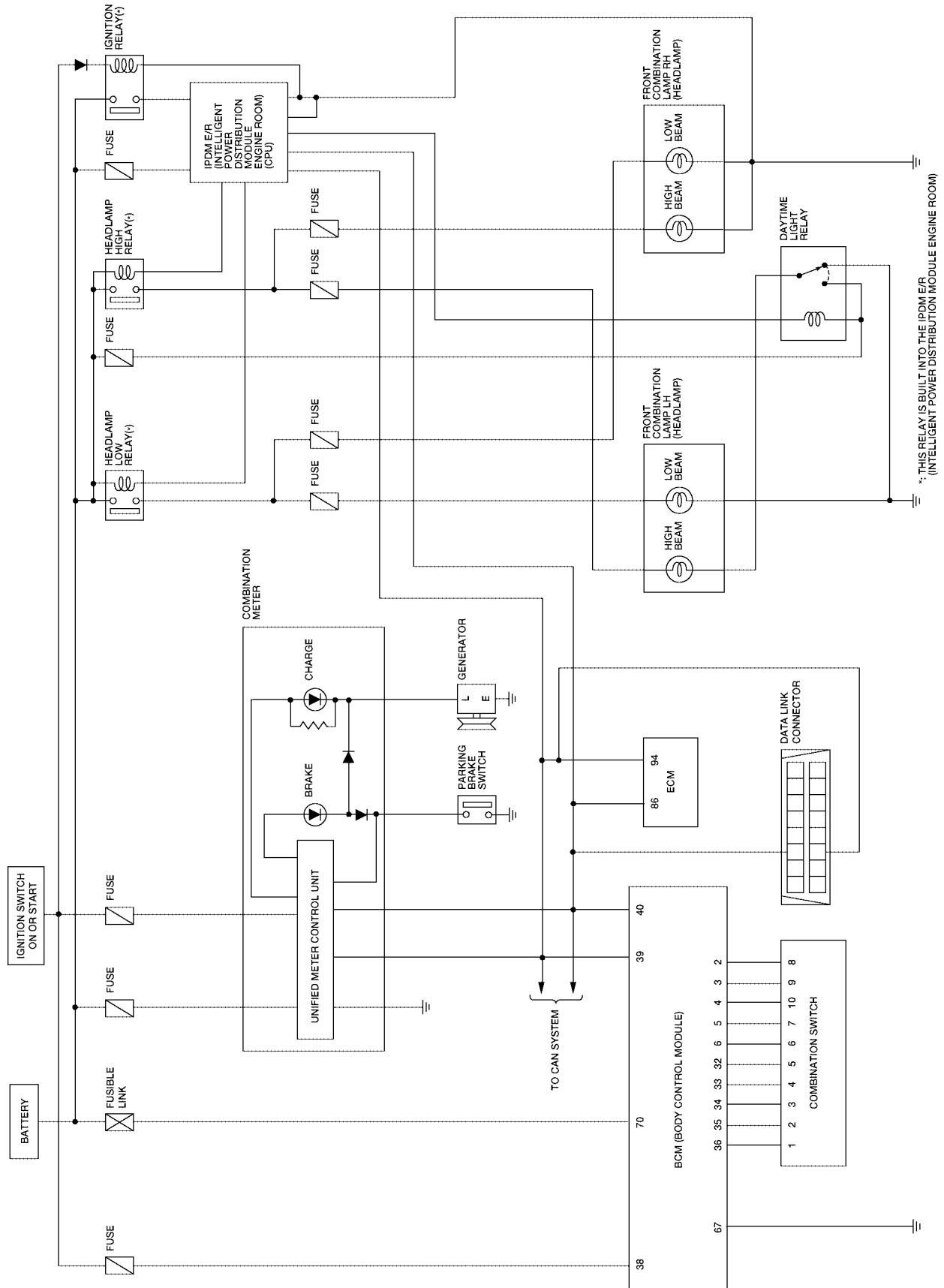

WKWA1486E

HEADLAMP (FOR CANADA) - DAYTIME LIGHT SYSTEM -

Wiring Diagram — DTRL —

EKS0073T

LT-DTRL-01

▬ : DATA LINE

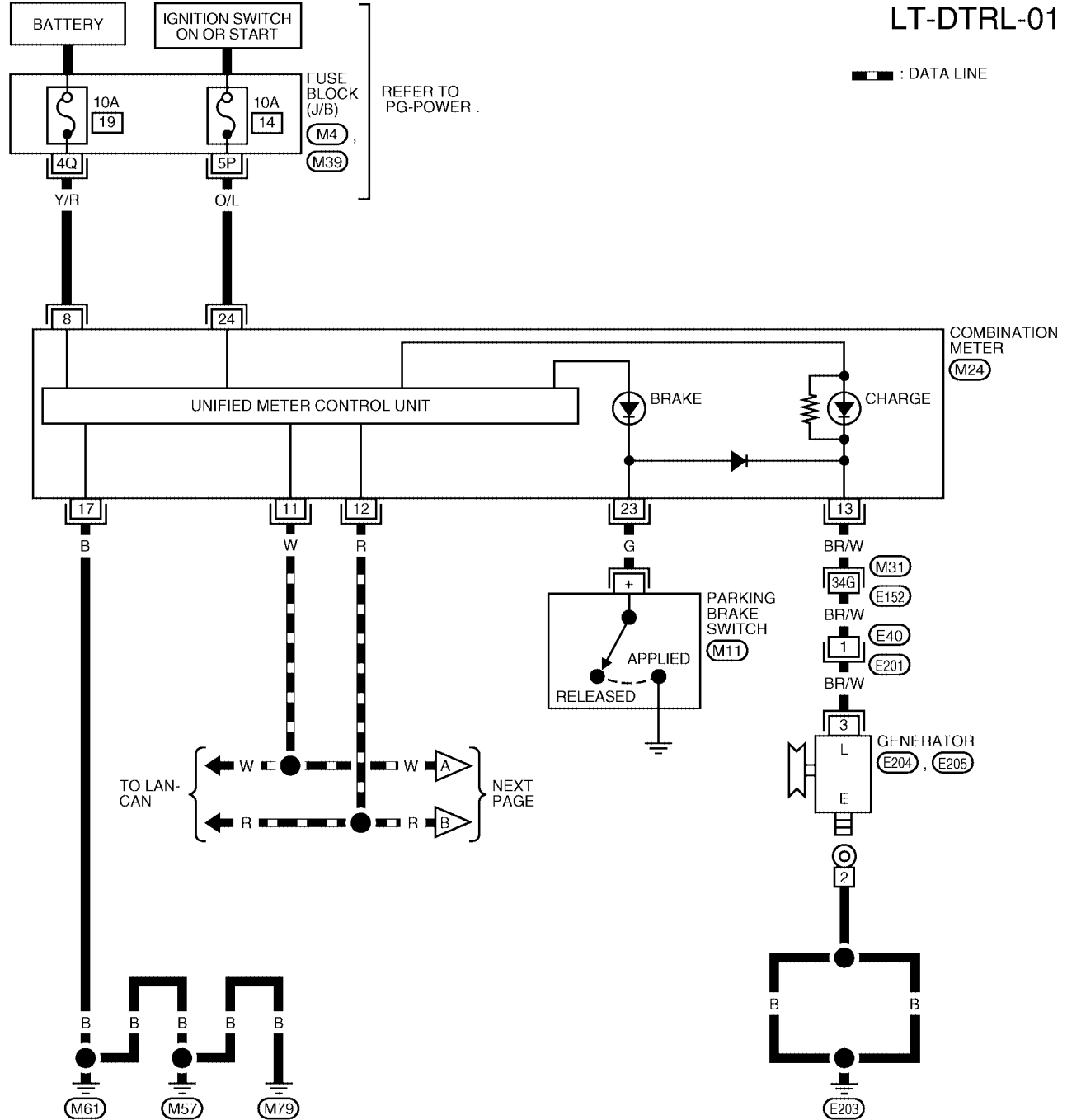

A
B
C
D
E
F
G
H
I
J
LT
L
M

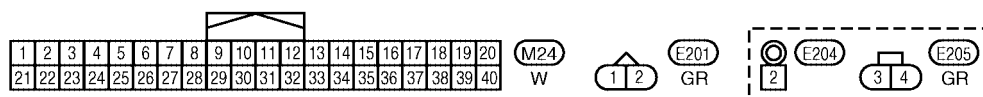
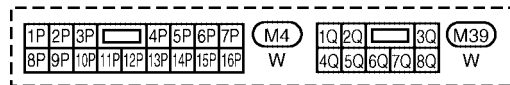

REFER TO THE FOLLOWING.
(M31) - SUPER MULTIPLE JUNCTION (SMJ)

WKWA1400E

HEADLAMP (FOR CANADA) - DAYTIME LIGHT SYSTEM -

LT-DTRL-02

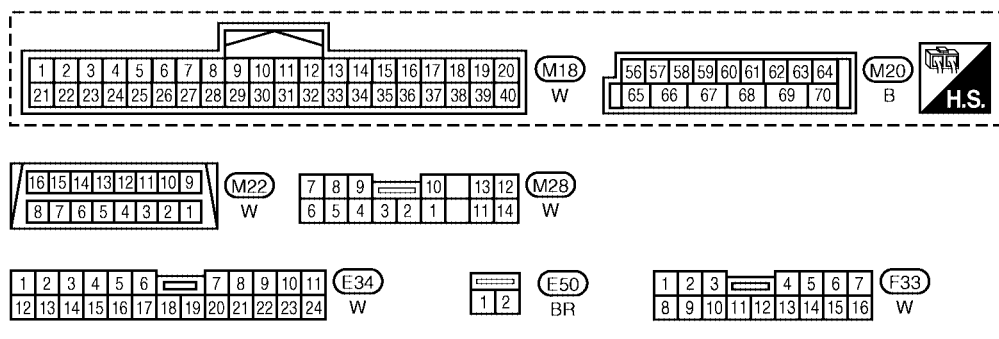
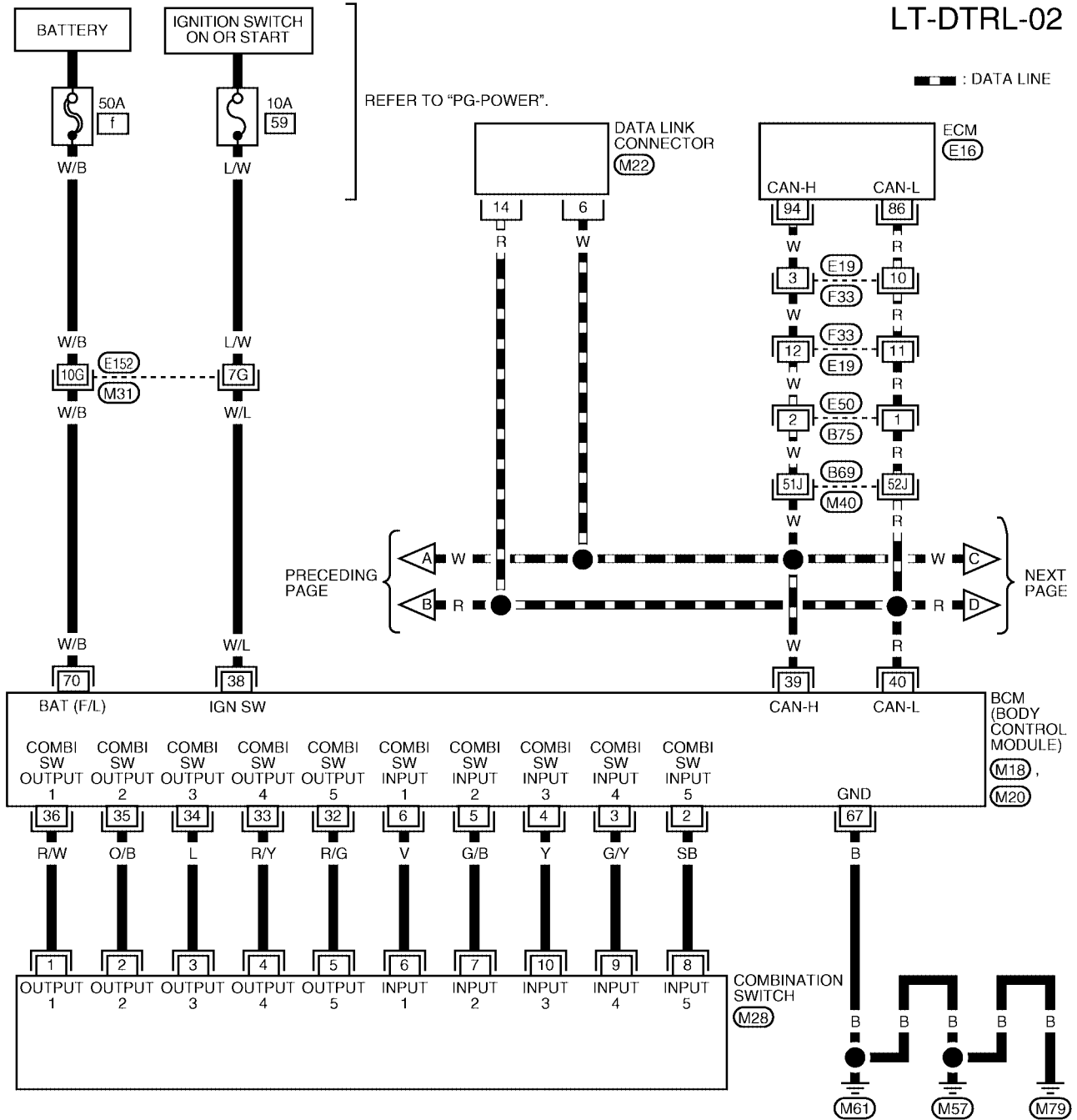

REFER TO THE FOLLOWING.
 (E16) - ELECTRICAL UNITS
 (M31), (M40) - SUPER MULTIPLE JUNCTION (SMJ)

WKWA1155E

HEADLAMP (FOR CANADA) - DAYTIME LIGHT SYSTEM -

LT-DTRL-03

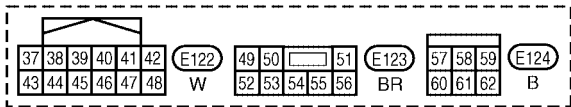
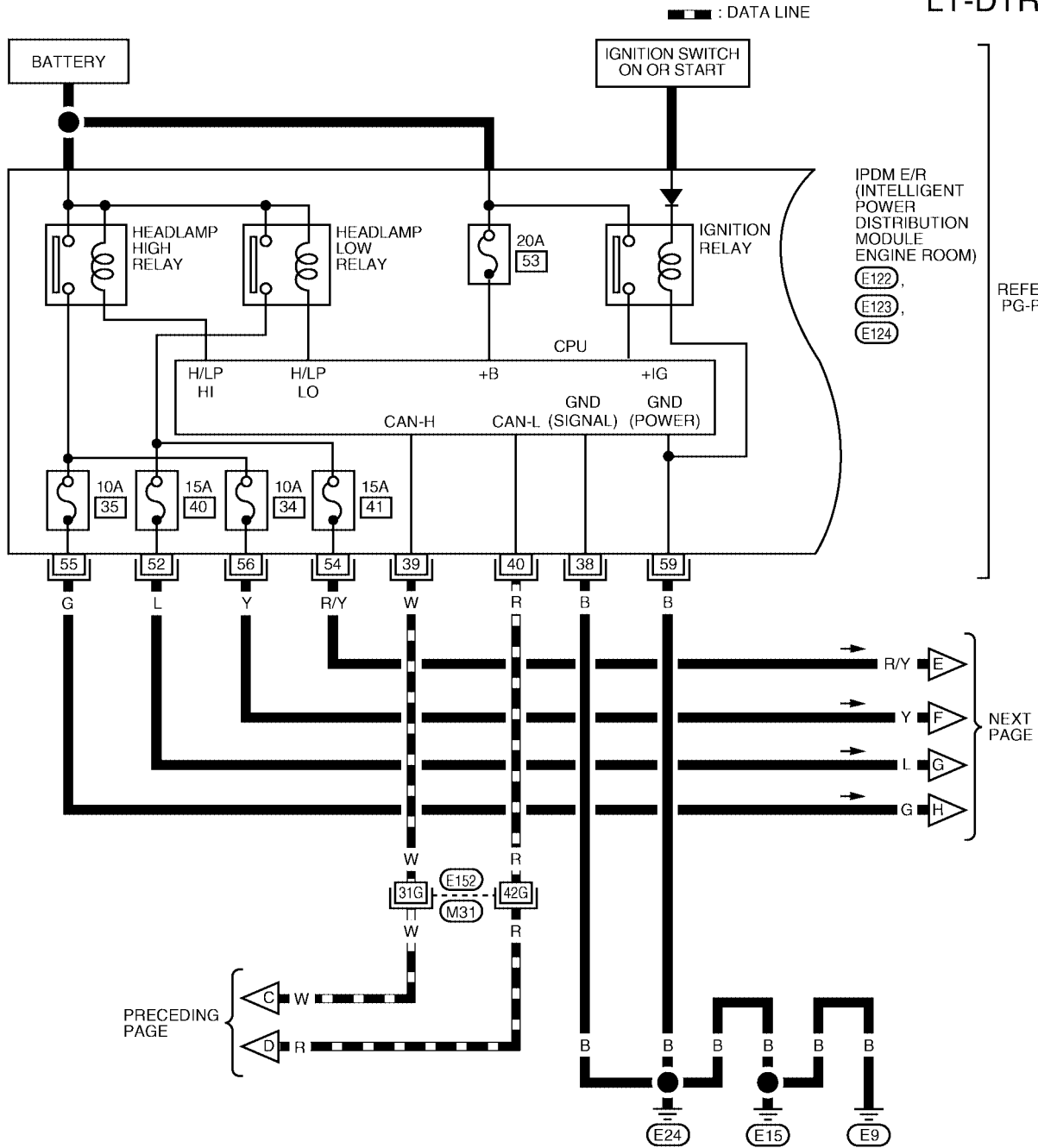

HEADLAMP (FOR CANADA) - DAYTIME LIGHT SYSTEM -

LT-DTRL-04

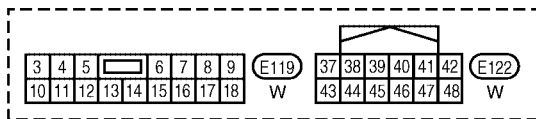
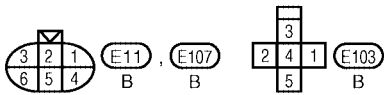
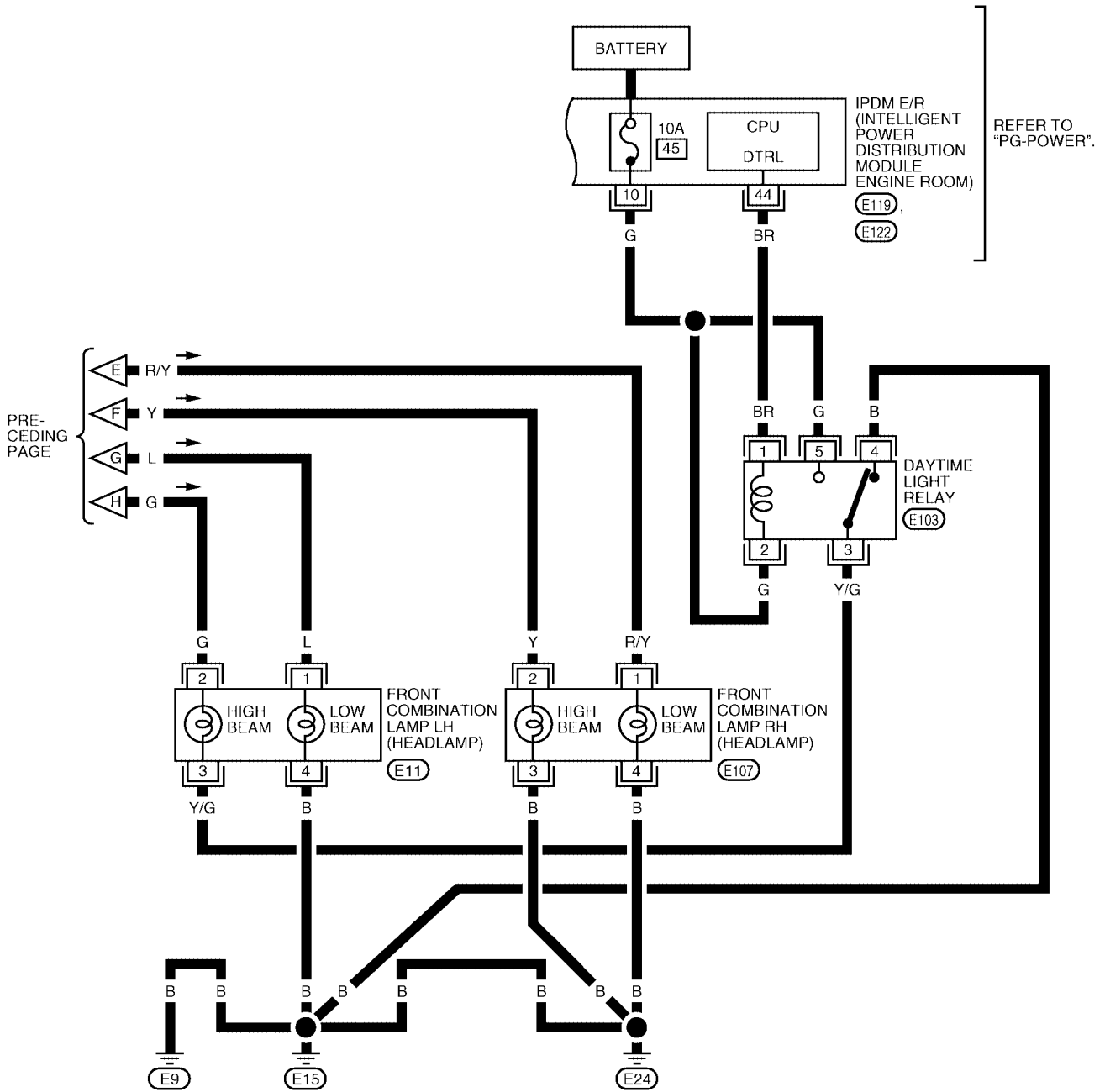





WKWA1476E

HEADLAMP (FOR CANADA) - DAYTIME LIGHT SYSTEM -

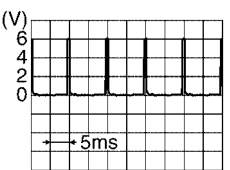
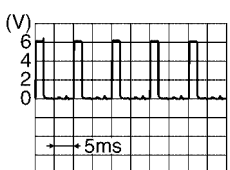
Terminals and Reference Value for BCM

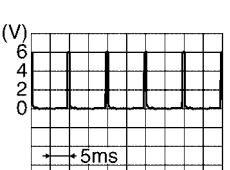
EKS0073U

Terminal No.	Wire color	Signal name	Measuring condition		Reference value (Approx.)
			Ignition switch	Operation or condition	
2	SB	Combination switch input 5	ON	Lighting, turn, wiper OFF Wiper dial position 4	 <p style="text-align: right; font-size: small;">SKIA5291E</p>
3	G/Y	Combination switch input 4	ON	Lighting, turn, wiper OFF Wiper dial position 4	 <p style="text-align: right; font-size: small;">SKIA5292E</p>
4	Y	Combination switch input 3	ON	Lighting, turn, wiper OFF Wiper dial position 4	 <p style="text-align: right; font-size: small;">SKIA5291E</p>
5	G/B	Combination switch input 2	ON	Lighting, turn, wiper OFF Wiper dial position 4	 <p style="text-align: right; font-size: small;">SKIA5292E</p>
6	V	Combination switch input 1			
32	R/G	Combination switch output 5	ON	Lighting, turn, wiper OFF Wiper dial position 4	 <p style="text-align: right; font-size: small;">SKIA5291E</p>
33	R/Y	Combination switch output 4	ON	Lighting, turn, wiper OFF Wiper dial position 4	 <p style="text-align: right; font-size: small;">SKIA5292E</p>
34	L	Combination switch output 3	ON	Lighting, turn, wiper OFF Wiper dial position 4	 <p style="text-align: right; font-size: small;">SKIA5291E</p>

A
B
C
D
E
F
G
H
I
J
LT
L
M

HEADLAMP (FOR CANADA) - DAYTIME LIGHT SYSTEM -

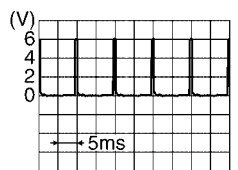
Terminal No.	Wire color	Signal name	Measuring condition		Reference value (Approx.)
			Ignition switch	Operation or condition	
35	O/B	Combination switch output 2	ON	Lighting, turn, wiper OFF Wiper dial position 4	 SKIA5292E
36	R/W	Combination switch output 1			
38	W/L	Ignition switch (ON)	ON	—	Battery voltage
39	W	CAN- H	—	—	—
40	R	CAN- L	—	—	—
67	B	Ground	ON	—	0V
70	W/B	Battery power supply (fusible link)	OFF	—	Battery voltage

How to Proceed With Trouble Diagnosis

EKS0073V

1. Confirm the symptom or customer complaint.
2. Understand operation description and function description. Refer to [LT-37, "System Description"](#).
3. Perform the Preliminary Check. Refer to [LT-44, "Preliminary Check"](#).
4. Check symptom and repair or replace the cause of malfunction.
5. Does the headlamp operate normally? If YES: GO TO 6. If NO: GO TO 4.
6. INSPECTION END.

Preliminary Check

EKS0073W

CHECK BCM CONFIGURATION

1. CHECK BCM CONFIGURATION

Confirm BCM configuration for "DTRL" is set to "WITH". Refer to [BCS-13, "READ CONFIGURATION PROCEDURE"](#).

OK or NG

OK >> Continue preliminary check. Refer to [LT-44, "INSPECTION FOR POWER SUPPLY AND GROUND CIRCUIT"](#).

NG >> Change BCM configuration for "DTRL" to "WITH". Refer to [BCS-16, "WRITE CONFIGURATION PROCEDURE"](#).

INSPECTION FOR POWER SUPPLY AND GROUND CIRCUIT

1. CHECK FUSES AND FUSIBLE LINK

Check for blown fuses or fusible link.

Unit	Power source	Fuse No.
BCM	Battery	f
	Ignition switch ON or START position	59
Daytime light relay	Battery	45

Refer to [LT-39, "Wiring Diagram — DTRL —"](#).

OK or NG

OK >> GO TO 2.

NG >> If fuse is blown, be sure to eliminate cause of malfunction before installing new fuse. Refer to [PG-4, "POWER SUPPLY ROUTING CIRCUIT"](#).

HEADLAMP (FOR CANADA) - DAYTIME LIGHT SYSTEM -

2. CHECK POWER SUPPLY CIRCUIT

1. Disconnect BCM connector.
2. Check voltage between BCM harness connector and ground.

Terminals		Ignition switch position		
(+)		(-)	OFF	ON
Connector	Terminal (Wire color)		OFF	ON
M18	38 (W/L)	Ground	0V	Battery voltage
M20	70 (W/B)		Battery voltage	Battery voltage

OK or NG

OK >> GO TO 3.

NG >> Check harness for open or short between BCM and fuse.

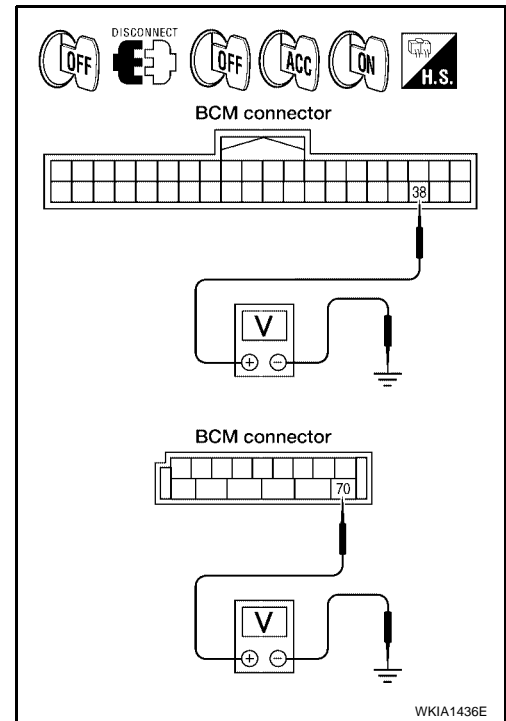

3. CHECK GROUND CIRCUIT

Check continuity between BCM harness connector and ground.

Terminals		(-)	Continuity
(+)			
Connector	Terminal (Wire color)	Ground	
M20	67 (B)	Ground	Yes

OK or NG

OK >> INSPECTION END.

NG >> Check ground circuit harness.

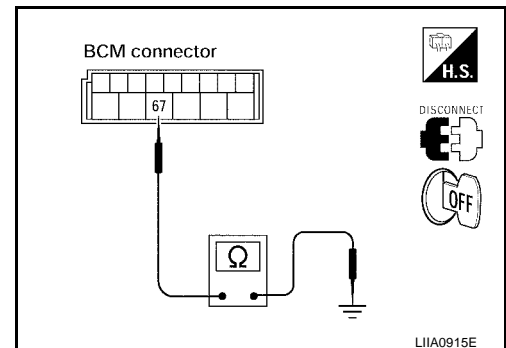

INSPECTION PARKING BRAKE SWITCH CIRCUIT

1. CHECK BRAKE INDICATOR

1. Turn ignition switch ON.
2. When parking brake is switched ON/OFF, check whether the brake indicator lamp of combination meter lights up / puts out the light.

OK or NG

OK >> INSPECTION END.

NG >> GO TO 2.

A
B
C
D
E
F
G
H
I
J
LT
L
M

HEADLAMP (FOR CANADA) - DAYTIME LIGHT SYSTEM -

2. CHECK PARKING BRAKE SWITCH SIGNAL

1. Disconnect parking brake switch connector.
2. Turn ignition switch ON.
3. Check voltage between parking brake switch harness connector M11 terminal + (G) and ground.

+ (G) – Ground : Battery voltage should exist.

OK or NG

- OK >> Replace parking brake switch.
 NG >> GO TO 3.

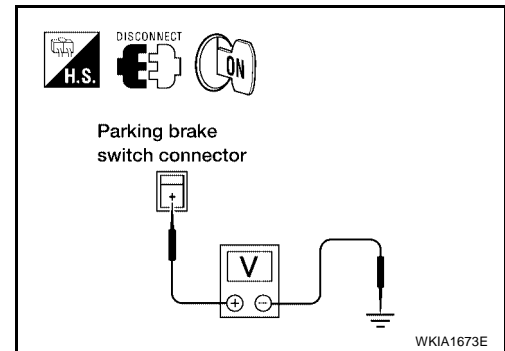

3. CHECK PARKING BRAKE SWITCH CIRCUIT

1. Turn ignition switch OFF.
2. Disconnect combination meter connector.
3. Check continuity between combination meter harness connector M24 terminal 23 (G) and parking brake switch harness connector M11 terminal + (G).

+ (G) – 23 (G) : Continuity should exist.

OK or NG

- OK >> Replace combination meter.
 NG >> Repair harness or connector.

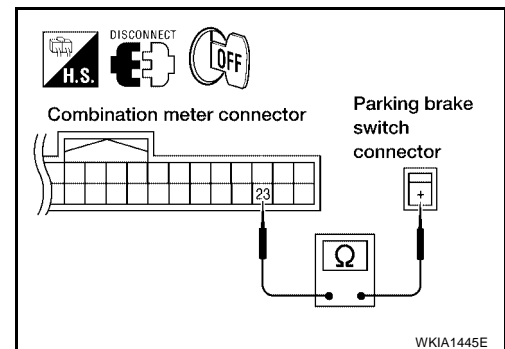

EKS0073X

CONSULT-II Functions

CONSULT-II can display each diagnostic item using the diagnostic test modes shown following.

BCM diagnosis part	Check item, diagnosis mode	Description
HEAD LAMP	Data monitor	Displays BCM input data in real time.
	Active test	Operation of electrical loads can be checked by sending drive signal to them.
BCM	Self-diagnosis	BCM performs self-diagnosis of CAN communication and combination switch.
	CAN DIAG SUPPORT MNTR	The result of transmit/receive diagnosis of CAN communication can be read.

CONSULT-II BASIC OPERATION

Refer to [LT-21, "CONSULT-II Functions \(IPDM E/R\)"](#) in "HEADLAMP (FOR USA)".

Daytime Light Control Does Not Operate Properly (Normal Headlamps Operate Properly)

EKS0073Y

1. CHECK DAYTIME LIGHT RELAY POWER SUPPLY CIRCUIT

1. Remove daytime light relay.
2. Check voltage between daytime light relay harness connector E103 terminals 2 (G), 5 (G) and ground

2 (G), 5 (G) – Ground : Battery voltage should exist.

OK or NG

- OK >> GO TO 2.
 NG >> Repair harness or connector.

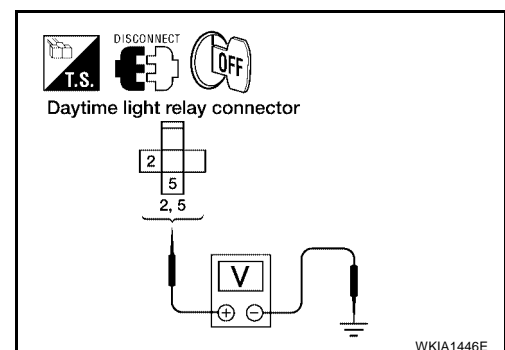

HEADLAMP (FOR CANADA) - DAYTIME LIGHT SYSTEM -

2. CHECK DAYTIME LIGHT RELAY

1. Apply battery voltage to daytime light relay terminal 1 and ground daytime light relay terminal 2.
2. Check continuity between terminals 3 and 5.

3 – 5 : Continuity should exist.

OK or NG

- OK >> GO TO 3.
 NG >> Replace daytime light relay.

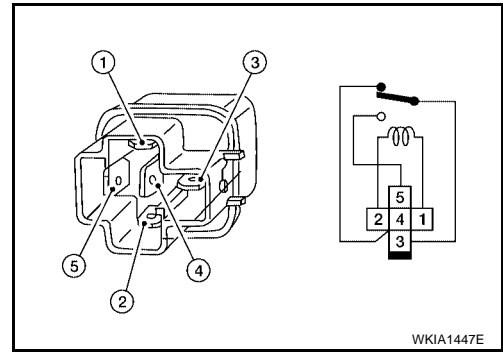

3. CHECK DAYTIME LIGHT RELAY CIRCUIT

1. Disconnect front combination lamp LH connector.
2. Check continuity between daytime light relay connector E103 terminal 3 (Y/G) and front combination lamp LH harness connector E11 terminal 3 (Y/G).

3 (Y/G) – 3 (Y/G) : Continuity should exist.

OK or NG

- OK >> GO TO 4.
 NG >> Repair harness or connector.

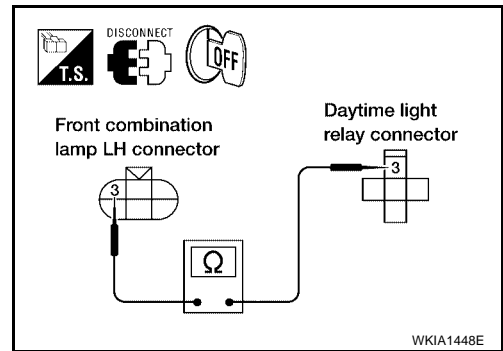

4. CHECK INPUT SIGNAL

1. Connect daytime light relay and front combination lamp LH connector.
2. Start engine and release parking brake. Headlamp switch OFF.
3. Select "IPDM E/R" on CONSULT-II. With data monitor, make sure "DTRL REQ" turns ON-OFF linked with operation of parking brake switch.

Parking brake ON : DTRL REQ ON
Parking brake OFF : DTRL REQ OFF

OK or NG

- OK >> Replace IPDM E/R.
 NG >> GO TO 5.

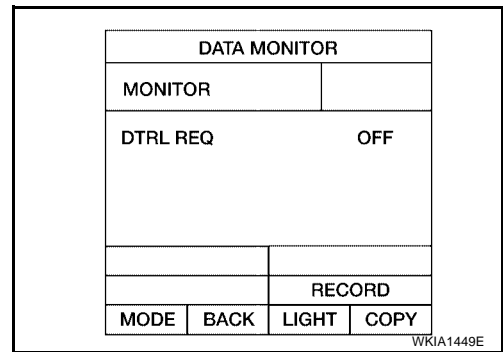

5. CHECKING CAN COMMUNICATIONS

Select "BCM" by CONSULT-II, and perform self-diagnosis for "BCM".
 Displayed self-diagnosis results

- NO DTC>>Replace BCM. Refer to [BCS-25, "Removal and Installation of BCM"](#) .
 CAN COMM CIRCUIT>> Check BCM CAN communication system.
 Refer to [BCS-13, "CAN Communication Inspection Using CONSULT-II \(Self-Diagnosis\)"](#) .

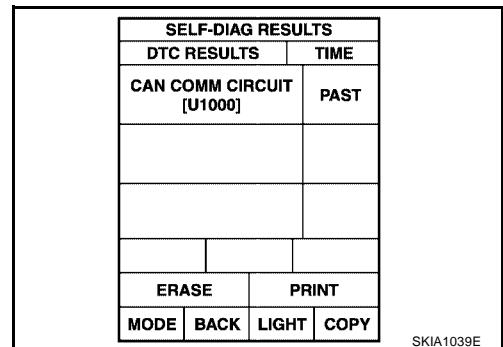

HEADLAMP (FOR CANADA) - DAYTIME LIGHT SYSTEM -

Aiming Adjustment

EKS0073Z

Refer to [LT-31, "Aiming Adjustment"](#) .

Bulb Replacement

EKS00740

Refer to [LT-35, "Disassembly and Assembly"](#) .

Removal and Installation

EKS00741

Refer to [LT-34, "Removal and Installation"](#) .

Disassembly and Assembly

EKS00742

Refer to [LT-35, "Disassembly and Assembly"](#) .

AUTO LIGHT SYSTEM

AUTO LIGHT SYSTEM

Component Parts and Harness Connector Location

PF2:28491

EKS00743

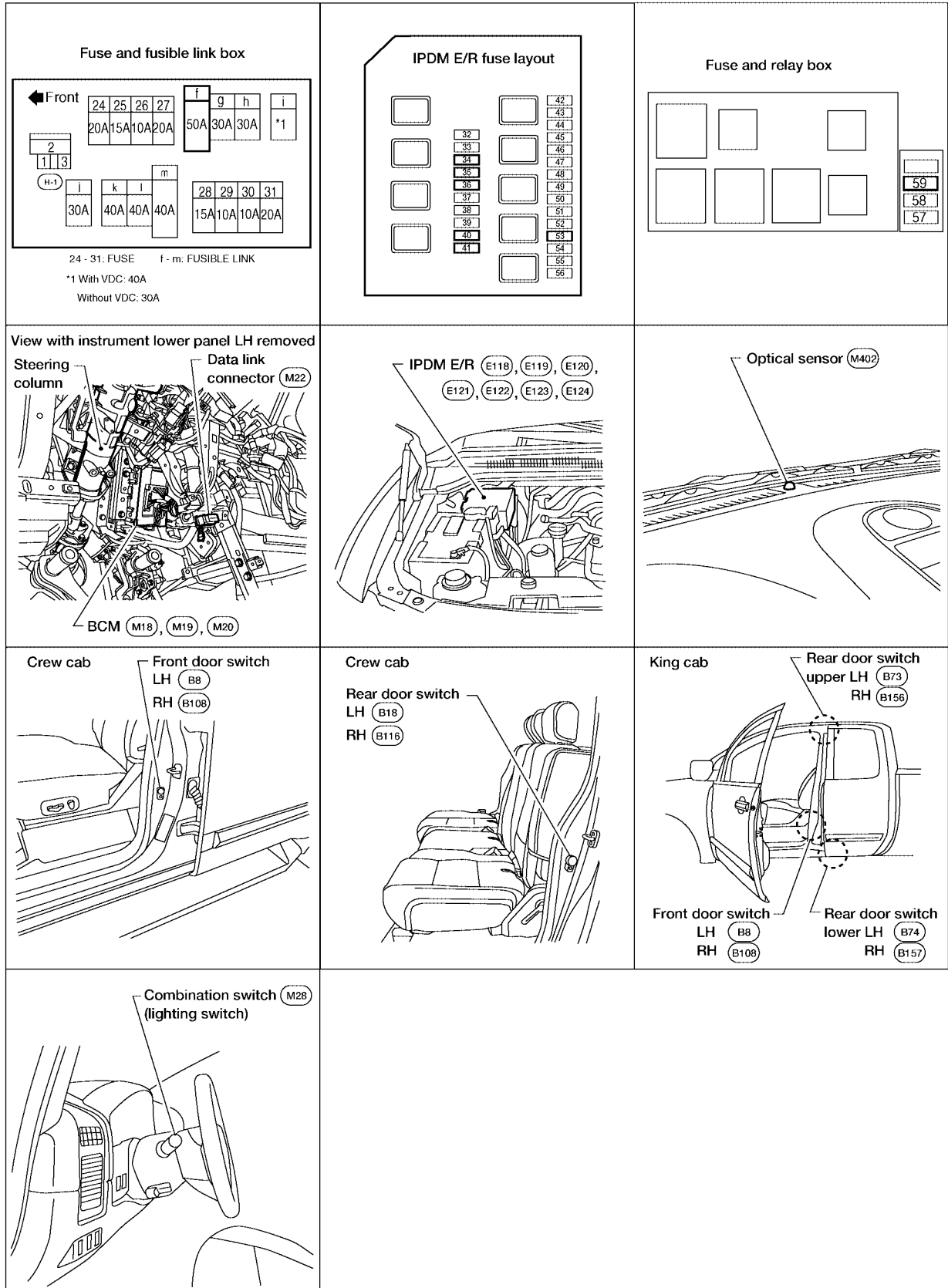

A
B
C
D
E
F
G
H
I
J
LT
L
M

AUTO LIGHT SYSTEM

System Description

EKS00744

Automatically turns on/off the parking lamps and the headlamps in accordance with ambient light. Timing for when the lamps turn on/off can be selected using four modes.

OUTLINE

The auto light control system uses an optical sensor that detects outside brightness.

When the lighting switch is in "AUTO" position, it automatically turns on/off the parking lamps and the headlamps in accordance with the ambient light. Sensitivity can be adjusted in four steps. For the details of the setting, refer to [LT-58, "SETTING CHANGE FUNCTIONS"](#).

Optical sensor ground is supplied

- from BCM (body control module) terminal 18
- to optical sensor terminal 3.

When ignition switch is turned to "ON" position and when outside brightness is darker than prescribed level, input is supplied

- to BCM (body control module) terminal 58
- from optical sensor terminal 4.

The headlamps will then illuminate. For a description of headlamp operation, refer to [LT-7, "System Description"](#).

COMBINATION SWITCH READING FUNCTION

Refer to [LT-97, "Combination Switch Reading Function"](#).

EXTERIOR LAMP BATTERY SAVER CONTROL

When the combination switch (lighting switch) is in the AUTO position, and the ignition switch is turned from ON or ACC to OFF, and one of the front doors is opened, the battery saver control feature is activated.

Under this condition, the headlamps remain illuminated for 5 minutes, then the headlamps are turned off.

Exterior lamp battery saver control mode can be changed by the function setting of CONSULT-II.

DELAY TIMER FUNCTION

When the ignition switch is ON and auto light switch is ON, the BCM turns on/off the headlamps. In delay timer function, ignition is OFF, auto light sensor power source is OFF and the headlamps are not turned on/off by the BCM. On condition that:

- when the state of ignition switch ON or ACC is ON and output judgment by auto light function is headlamp ON changes to ignition switch and ACC are OFF and any door switch is ON, output judgment by BCM should be headlamp ON for 5 minutes by timer. After time out, output judgment by BCM should be headlamp OFF.
- when the state of any door switch is turned to ON from OFF while 45 second or 5 minute timer is counting, timer stops, and restarts counting for 5 minutes, then BCM judges output as headlamp ON. After time out, BCM judges output as headlamp OFF.
- when the state of front door switch (driver side), front door switch (passenger side), rear door switch LH, rear door switch RH or back door latch (door ajar switch) is ON turns to all door switches are OFF while 45 second or 5 minute timer is counting, timer stops, and restarts counting for 45 seconds, then BCM judges output as headlamp ON. After timer out, BCM judges output as headlamp OFF.
- when the state is ignition switch ON or ACC is ON or auto light switch OFF while timer is counting, timer stops counting and BCM turns on/off lamps according to headlamp function, front fog lamp function, auto light function and headlamp battery save function.

Delay timer control mode can be changed by the function setting of CONSULT-II.

CAN Communication System Description

EKS00745

Refer to [LAN-8, "CAN COMMUNICATION"](#).

AUTO LIGHT SYSTEM

Major Components and Functions

EKS00746

Components	Functions
BCM	<ul style="list-style-type: none">● Turns on/off circuits of tail light and headlamp according to signals from light sensor, lighting switch (AUTO), driver door switch, passenger door switch, rear door switch, and ignition switch (ON, OFF).
Optical sensor	<ul style="list-style-type: none">● Converts ambient light (lux) to voltage, and sends it to BCM. (Detects lightness of 50 to 1,300 lux)

A

B

C

D

E

F

G

H

I

J

LT

L

M

AUTO LIGHT SYSTEM

Schematic

EKS00747

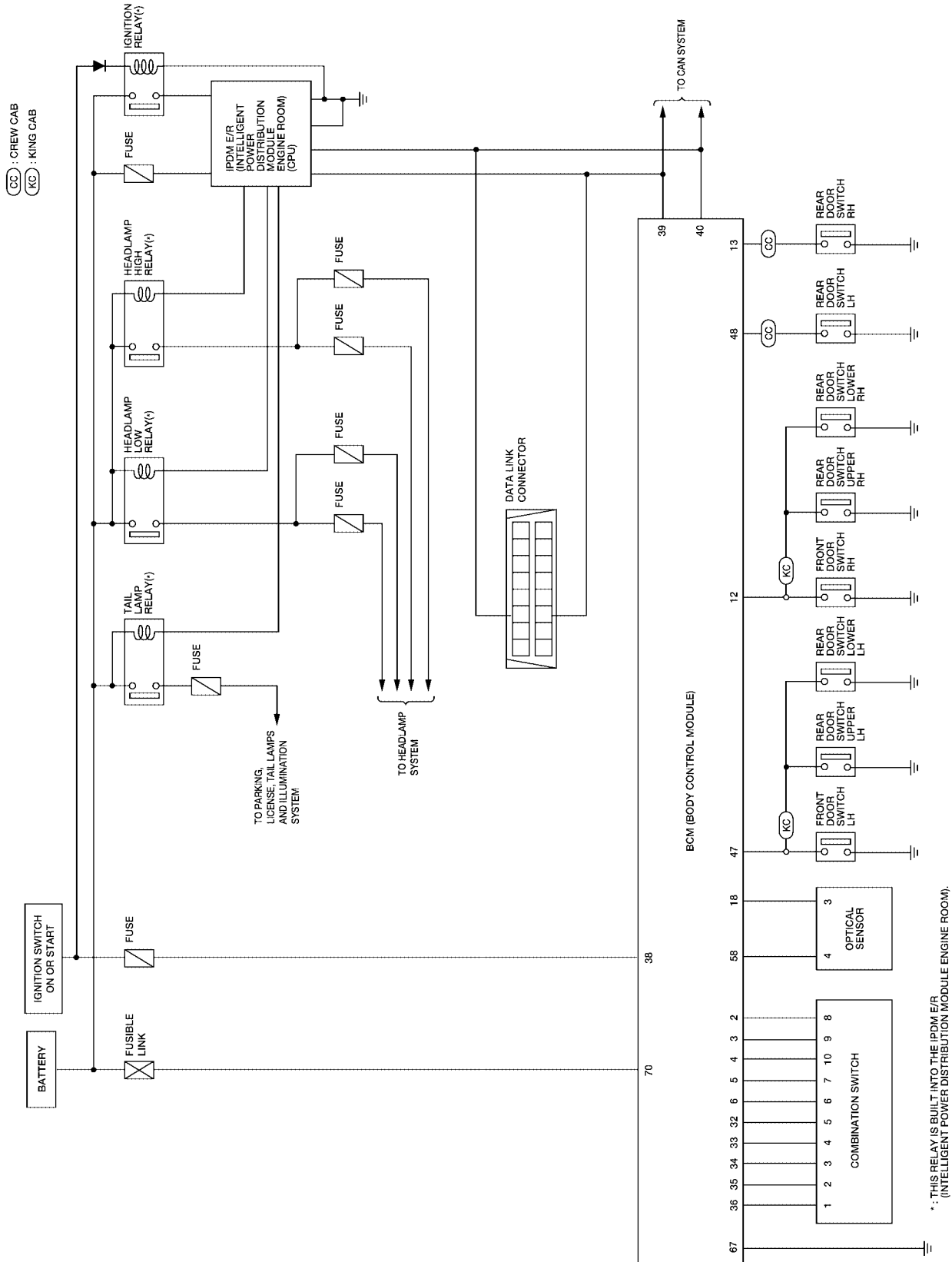

WKWA1062E

AUTO LIGHT SYSTEM

Wiring Diagram — AUTO/L —

EKS00748

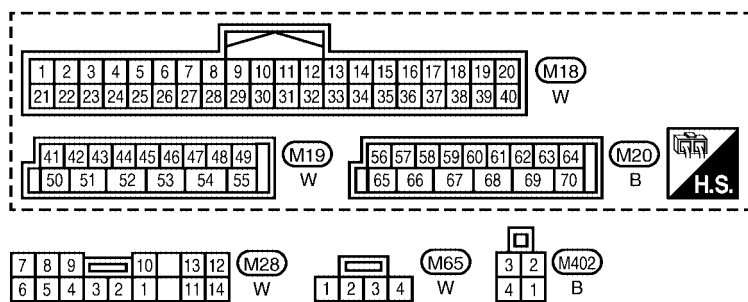
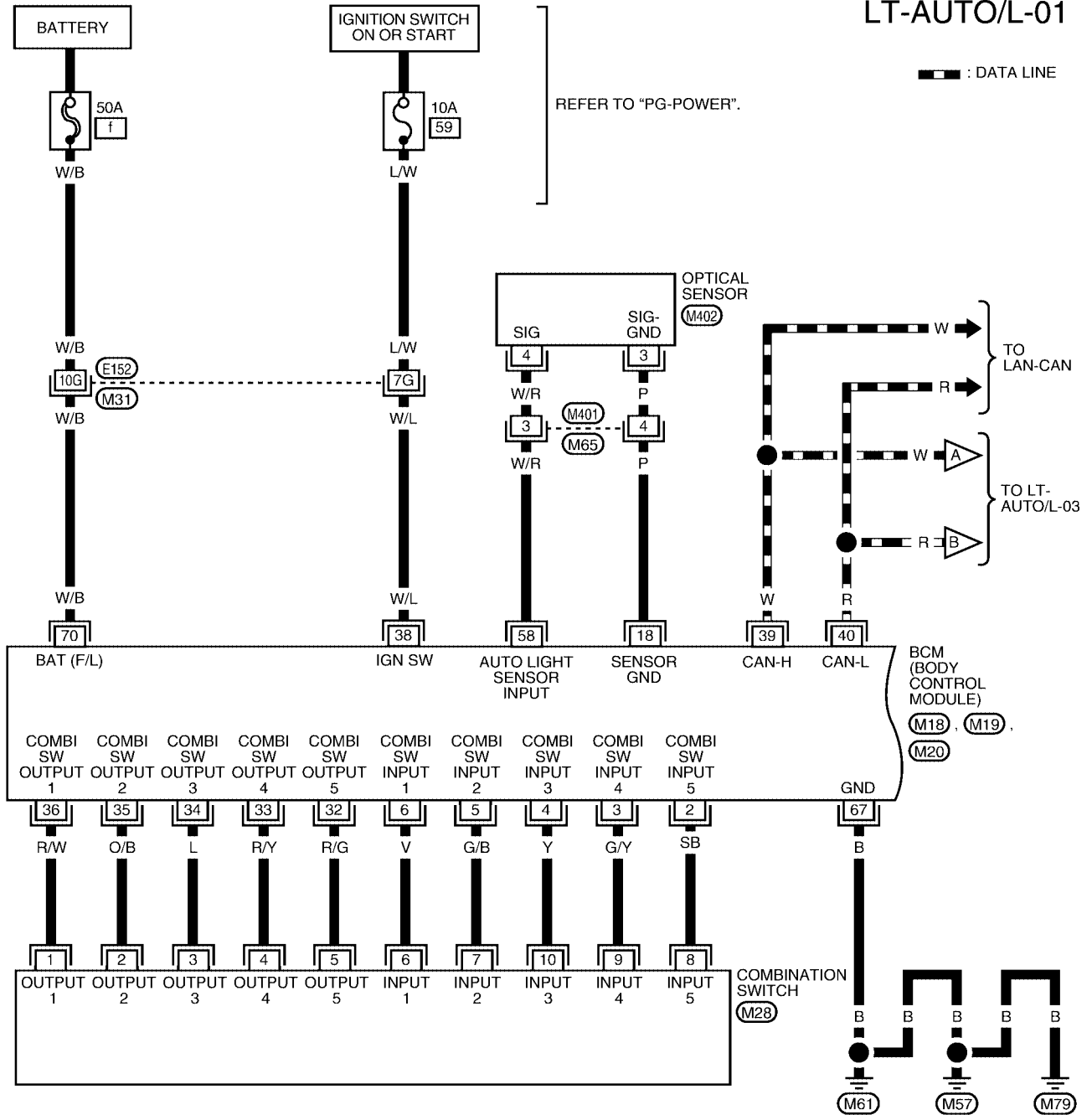

REFER TO THE FOLLOWING.
 (M31) - SUPER MULTIPLE JUNCTION (SMJ)

WKWA1156E

AUTO LIGHT SYSTEM

LT-AUTO/L-02

CC : CREW CAB
KC : KING CAB

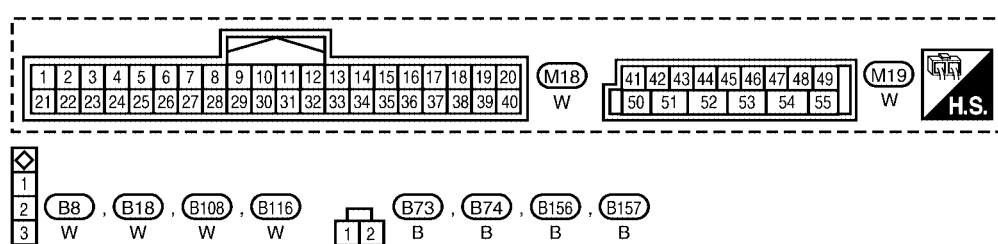
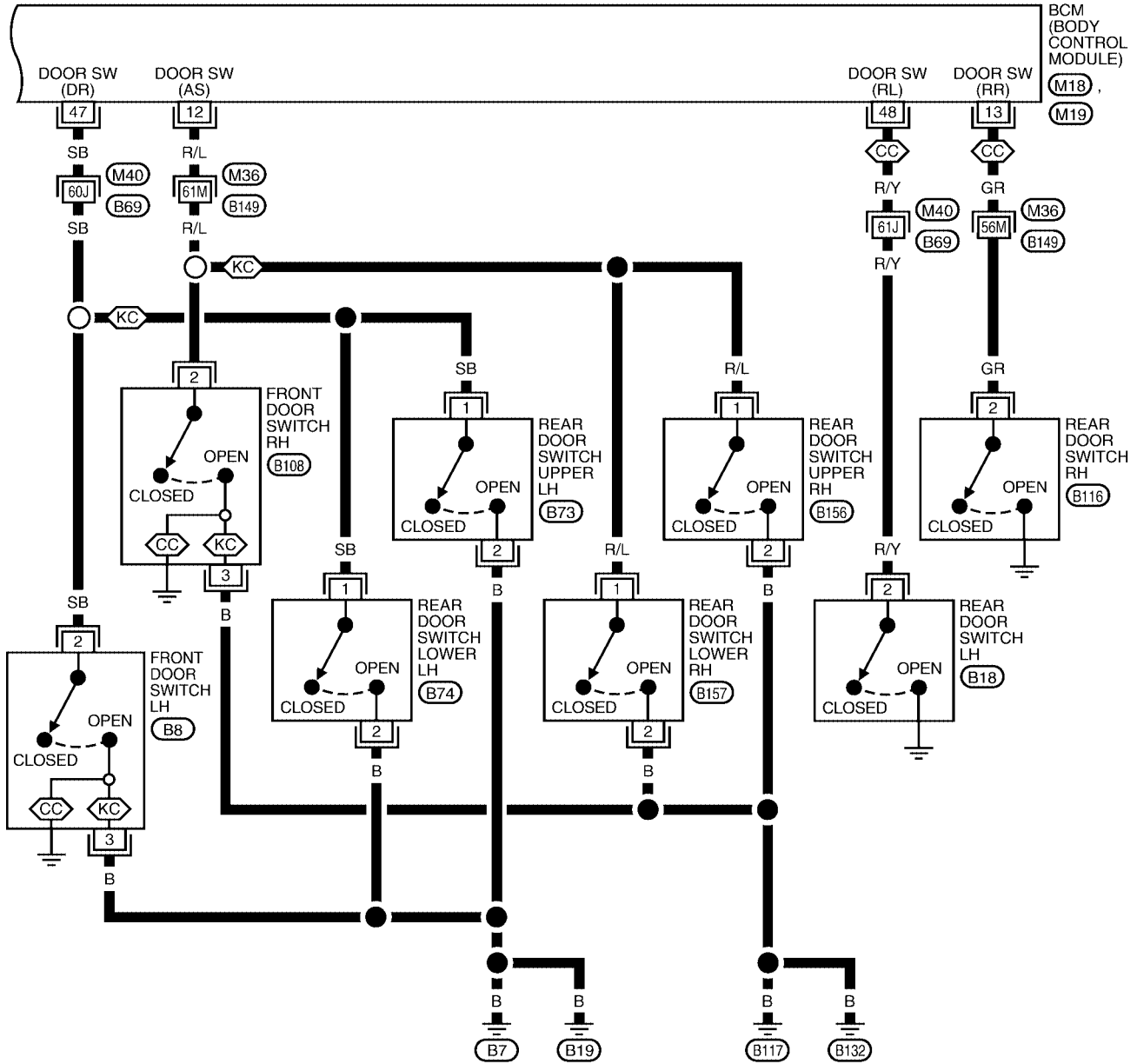

REFER TO THE FOLLOWING.
M36, M40 - SUPER
 MULTIPLE JUNCTION (SMJ)

LKWA0282E

AUTO LIGHT SYSTEM

LT-AUTO/L-03

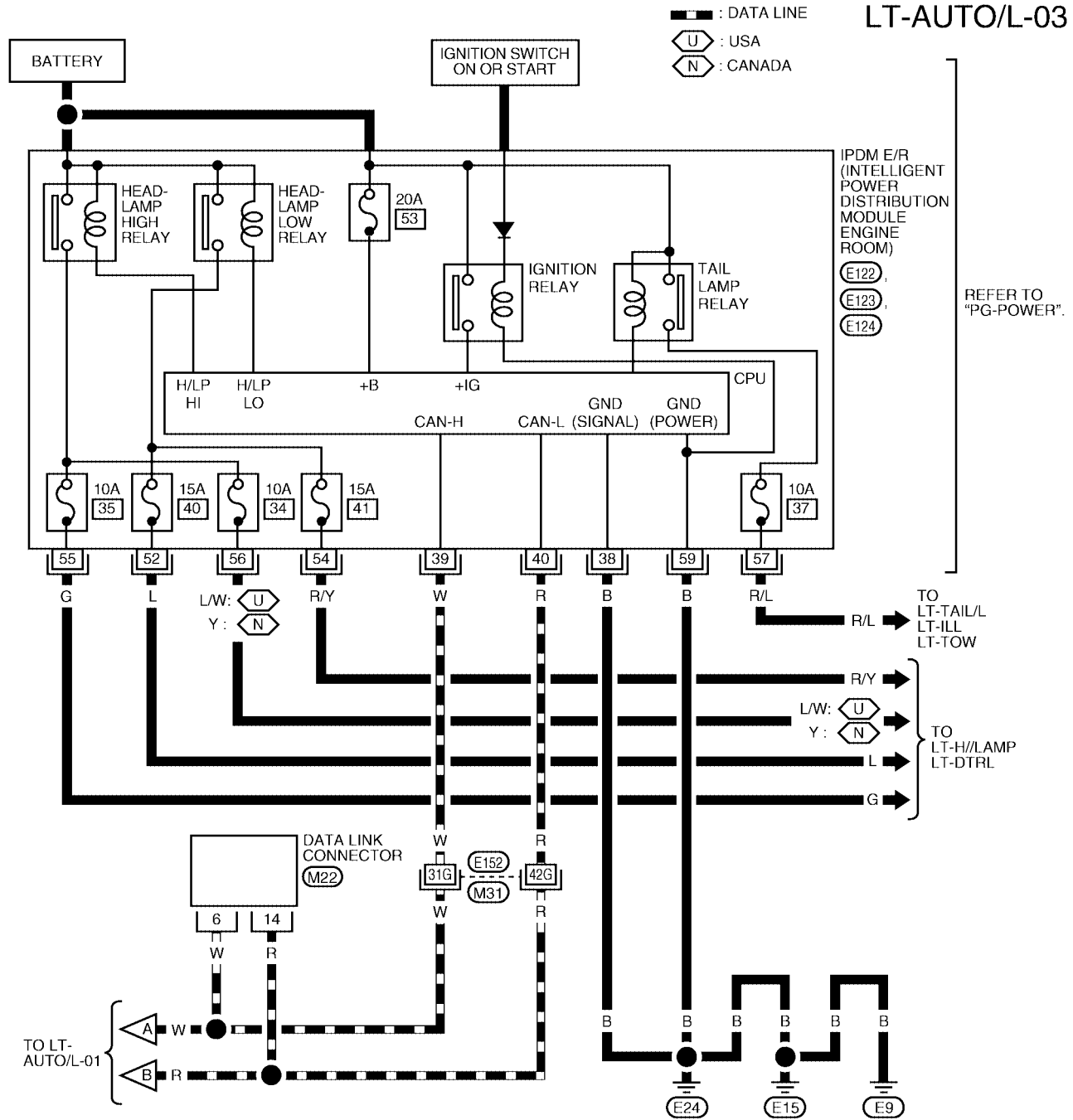

A
 B
 C
 D
 E
 F
 G
 H
 I
 J
 LT
 L
 M

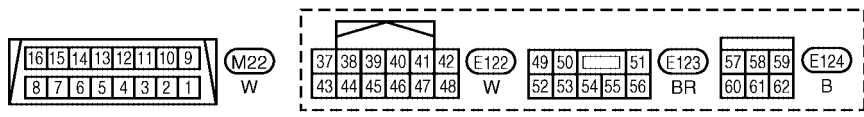
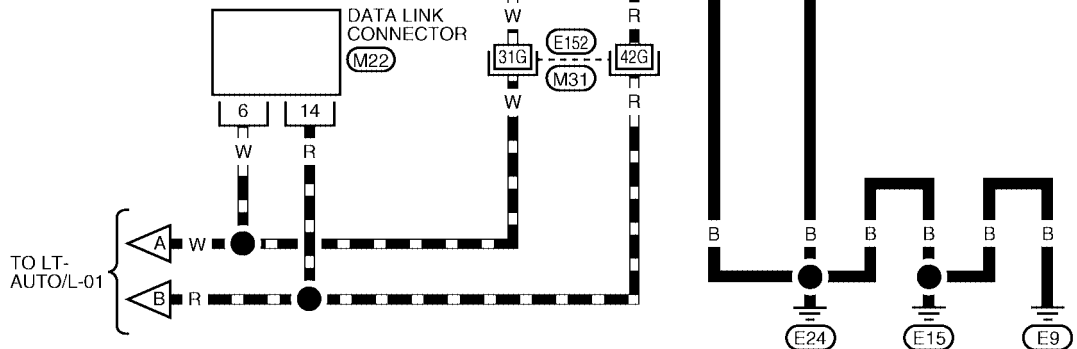



REFER TO THE FOLLOWING.
 M31 - SUPER MULTIPLE JUNCTION (SMJ)

WKWA1508E

AUTO LIGHT SYSTEM

Terminals and Reference Value for BCM

EKS00749

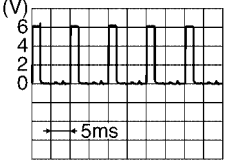
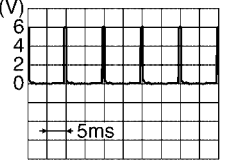
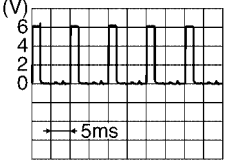
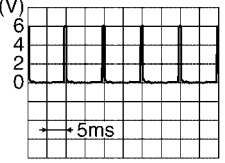
Terminal No.	Wire color	Signal name	Measuring condition		Reference value (Approx.)				
			Ignition switch	Operation or condition					
2	SB	Combination switch input 5	ON	Lighting, turn, wiper OFF Wiper dial position 4	 <p style="text-align: right;">SKIA5291E</p>				
3	G/Y	Combination switch input 4	ON	Lighting, turn, wiper OFF Wiper dial position 4	 <p style="text-align: right;">SKIA5292E</p>				
4	Y	Combination switch input 3	ON	Lighting, turn, wiper OFF Wiper dial position 4	 <p style="text-align: right;">SKIA5291E</p>				
5	G/B	Combination switch input 2	ON	Lighting, turn, wiper OFF Wiper dial position 4	 <p style="text-align: right;">SKIA5292E</p>				
6	V	Combination switch input 1							
12 (crew cab)	R/L	Front door switch RH signal	OFF	Front door switch RH	<table border="1" style="width: 100%; border-collapse: collapse;"> <tr> <td>ON (open)</td> <td>0V</td> </tr> <tr> <td>OFF (closed)</td> <td>Battery voltage</td> </tr> </table>	ON (open)	0V	OFF (closed)	Battery voltage
ON (open)	0V								
OFF (closed)	Battery voltage								
12 (king cab)	R/L	Door switch RH signal	OFF	Door switch RH	<table border="1" style="width: 100%; border-collapse: collapse;"> <tr> <td>ON (open)</td> <td>0V</td> </tr> <tr> <td>OFF (closed)</td> <td>Battery voltage</td> </tr> </table>	ON (open)	0V	OFF (closed)	Battery voltage
ON (open)	0V								
OFF (closed)	Battery voltage								
13 (crew cab)	GR	Rear door switch RH signal	OFF	Rear door switch RH	<table border="1" style="width: 100%; border-collapse: collapse;"> <tr> <td>ON (open)</td> <td>0V</td> </tr> <tr> <td>OFF (closed)</td> <td>Battery voltage</td> </tr> </table>	ON (open)	0V	OFF (closed)	Battery voltage
ON (open)	0V								
OFF (closed)	Battery voltage								
18	P	Sensor ground	ON	—	0V				
32	R/G	Combination switch output 5	ON	Lighting, turn, wiper OFF Wiper dial position 4	 <p style="text-align: right;">SKIA5291E</p>				
33	R/Y	Combination switch output 4	ON	Lighting, turn, wiper OFF Wiper dial position 4	 <p style="text-align: right;">SKIA5292E</p>				

AUTO LIGHT SYSTEM

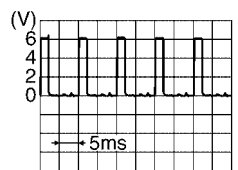
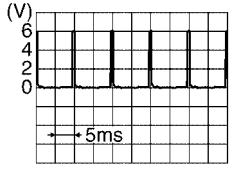
Terminal No.	Wire color	Signal name	Measuring condition		Reference value (Approx.)	
			Ignition switch	Operation or condition		
34	L	Combination switch output 3	ON	Lighting, turn, wiper OFF Wiper dial position 4	 SKIA5291E	
35	O/B	Combination switch output 2	ON	Lighting, turn, wiper OFF Wiper dial position 4	 SKIA5292E	
36	R/W	Combination switch output 1				
38	W/L	Ignition switch (ON)	ON	—	Battery voltage	
39	W	CAN- H	—	—	—	
40	R	CAN- L	—	—	—	
47 (crew cab)	SB	Front door switch LH signal	OFF	Front door switch LH	ON (open)	0V
					OFF (closed)	Battery voltage
47 (king cab)	SB	Door switch LH signal	OFF	Door switch LH	ON (open)	0V
					OFF (closed)	Battery voltage
48 (crew cab)	R/Y	Rear door switch LH signal	OFF	Rear door switch LH	ON (open)	0V
					OFF (closed)	Battery voltage
58	W/R	Optical sensor signal	ON	When optical sensor is illuminated	Less than 3.5V ^{Note}	
				When optical sensor is not illuminated	Greater than 3.5V	
67	B	Ground	ON	—	0V	
70	W/B	Battery power supply	OFF	—	Battery voltage	

NOTE:

Optical sensor must be completely subjected to work lamp light. If the optical sensor is insufficiently illuminated, the measured value may not satisfy standard.

Terminals and Reference Values for IPDM E/R

EKS0074A

Terminal No.	Wire color	Signal name	Measuring condition		Reference value (Approx.)	
			Ignition switch	Operation or condition		
38	B	Ground	ON	—	0V	
39	W	CAN- H	—	—	—	
40	R	CAN- L	—	—	—	
52	L	Headlamp low (LH)	ON	Lighting switch 2ND position	OFF	0V
					ON	Battery voltage
54	R/Y	Headlamp low (RH)	ON	Lighting switch 2ND position	OFF	0V
					ON	Battery voltage
55	G	Headlamp high (LH)	ON	Lighting switch HIGH or PASS position	OFF	0V
					ON	Battery voltage

AUTO LIGHT SYSTEM

Terminal No.	Wire color	Signal name	Measuring condition		Reference value (Approx.)
			Ignition switch	Operation or condition	
56	L/W (USA) Y (Canada)	Headlamp high (RH)	ON	Lighting switch HIGH or PASS position	OFF 0V
					ON Battery voltage
57	R/L	Parking, license, and tail lamp	ON	Lighting switch 1ST position	OFF 0V
					ON Battery voltage
59	B	Ground	ON	—	0V

How to Proceed With Trouble Diagnosis

EKS0074B

1. Confirm the symptom or customer complaint.
2. Understand operation description and function description. Refer to [LT-50, "System Description"](#).
3. Carry out the Preliminary Check. Refer to [LT-58, "Preliminary Check"](#).
4. Check symptom and repair or replace the cause of malfunction. Refer to [LT-65, "Trouble Diagnosis Chart by Symptom"](#).
5. Does the auto light system operate normally? If YES: GO TO 6. If NO: GO TO 4.
6. INSPECTION END.

Preliminary Check

EKS0074C

CHECK BCM CONFIGURATION

1. CHECK BCM CONFIGURATION

Confirm BCM configuration for "AUTO LIGHT" is set to "WITH". Refer to [BCS-13, "READ CONFIGURATION PROCEDURE"](#).

OK or NG

- OK >> Continue preliminary check. Refer to [LT-58, "CHECK POWER SUPPLY AND GROUND CIRCUIT"](#).
- NG >> Change BCM configuration for "AUTO LIGHT" to "WITH". Refer to [BCS-16, "WRITE CONFIGURATION PROCEDURE"](#).

SETTING CHANGE FUNCTIONS

- Sensitivity of auto light system can be adjusted using CONSULT-II. Refer to [LT-61, "WORK SUPPORT"](#).

CHECK POWER SUPPLY AND GROUND CIRCUIT

1. CHECK FUSES OR FUSIBLE LINK

Check for blown fuses or fusible link.

Unit	Power source	Fuse No.
BCM	Battery	f
	Ignition switch ON or START position	59
IPDM E/R	Battery	34
		35
		40
		41
		53

Refer to [LT-53, "Wiring Diagram — AUTO/L —"](#).

OK or NG

- OK >> GO TO 2.
- NG >> If fuse is blown, be sure to eliminate cause of malfunction before installing new fuse. Refer to [PG-4, "POWER SUPPLY ROUTING CIRCUIT"](#).

AUTO LIGHT SYSTEM

2. CHECK POWER SUPPLY CIRCUIT

1. Disconnect BCM connector.
2. Check voltage between BCM harness connector and ground.

Terminals		Ignition switch position			
(+)		(-)	OFF	ACC	ON
Connector	Terminal (Wire color)				
M18	38 (W/L)	Ground	0V	0V	Battery voltage
M20	70 (W/B)		Battery voltage	Battery voltage	Battery voltage

OK or NG

OK >> GO TO 3.

NG >> Check harness for open between BCM and fuse.

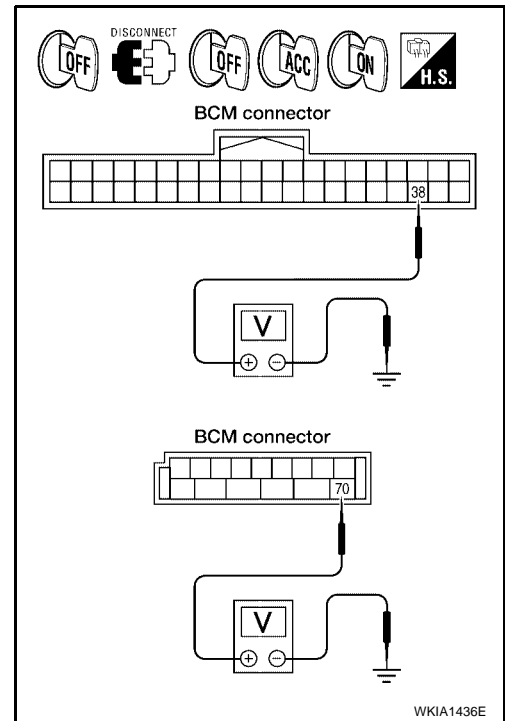

3. CHECK GROUND CIRCUIT

Check continuity between BCM harness connector and ground.

Terminals		(-)	Continuity
(+)			
Connector	Terminal (Wire color)		
M20	67 (B)	Ground	Yes

OK or NG

OK >> INSPECTION END.

NG >> Check ground circuit harness.

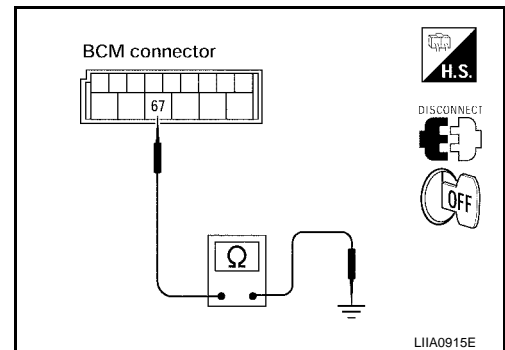

A
B
C
D
E
F
G
H
I
J
LT
L
M

AUTO LIGHT SYSTEM

EKS0074D

CONSULT-II Functions (BCM)

CONSULT-II can display each diagnostic item using the diagnostic test modes shown following.

BCM diagnosis part	Check item, diagnosis mode	Description
HEAD LAMP	Work support	Changes the setting for each function.
	Data monitor	Displays BCM input data in real time.
	Active Test	Operation of electrical loads can be checked by sending drive signal to them.
BCM	Self-diagnosis	BCM performs self-diagnosis of CAN communication.
	CAN DIAG SUPPORT MNTR	The result of transmit/receive diagnosis of CAN communication can be read.

CONSULT-II BASIC OPERATION

CAUTION:

If CONSULT-II is used with no connection of CONSULT-II CONVERTER, malfunctions might be detected in self-diagnosis depending on control unit which carries out CAN communication.

1. With the ignition switch OFF, connect CONSULT-II and CONSULT-II CONVERTER to the data link connector, then turn ignition switch ON.

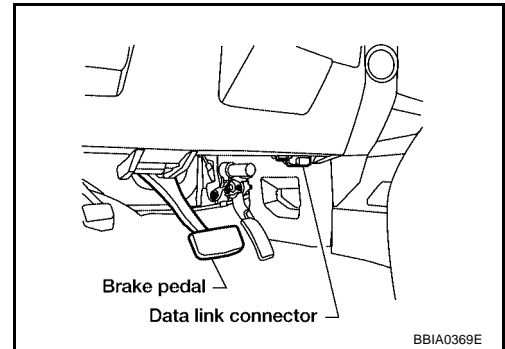

2. Touch "START (NISSAN BASED VHCL)".

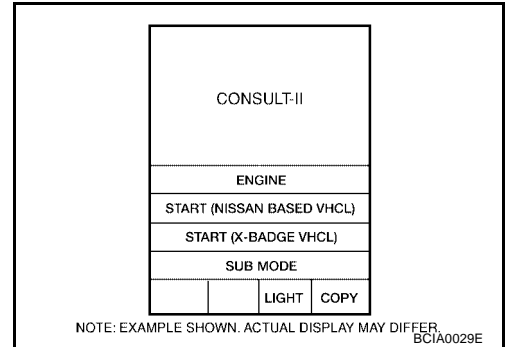

3. Touch "BCM" on "SELECT SYSTEM" screen.
If "BCM" is not indicated, go to [GI-38, "CONSULT-II Data Link Connector \(DLC\) Circuit"](#).

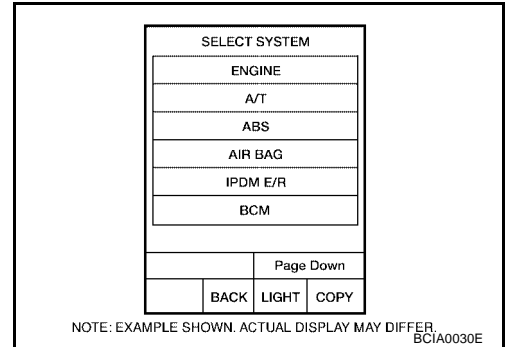

AUTO LIGHT SYSTEM

4. Touch "HEADLAMP" on "SELECT TEST ITEM" screen.

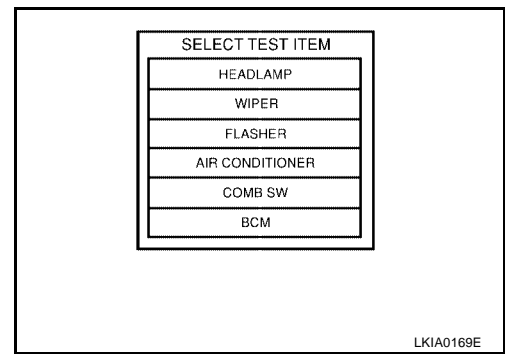

WORK SUPPORT

Operation Procedure

1. Touch "HEADLAMP" on "SELECT TEST ITEM" screen.
2. Touch "WORK SUPPORT" on "SELECT DIAG MODE" screen.
3. Touch "CUSTOM A/LIGHT SETTING" or "ILL DELAY SET" on "SELECT WORK ITEM" screen.
4. Touch "START".
5. Touch "MODE 1 - 4" of setting to be changed (CUSTOM A/LIGHT SETTING), Touch "MODE1-8" of setting to be changed. (ILL DELAY SET)
6. Touch "SETTING CHANGE".
7. The setting will be changed and "CUSTOMIZING COMPLETED" will be displayed.
8. Touch "END".

Work Support Setting Item

- Sensitivity of auto light can be selected and set from four modes.

Work item	Description
CUSTOM A/LIGHT SETTING	Auto light sensitivity can be changed in this mode. Sensitivity can be adjusted in four modes. ● MODE 1 (Normal-default)/ MODE 2 (Desensitized)/MODE 3 (Sensitive)/MODE4 (Insensitive)
ILL DELAY SET	Auto light delay off timer period can be changed in this mode. Selects auto light delay off timer period among eight modes. ● MODE 1 (45 sec.)/MODE 2 (OFF)/MODE 3 (30 sec.)/MODE 4 (60 sec.)/MODE 5 (90 sec.)/MODE 6 (120 sec.)/MODE 7 (150 sec.)/MODE 8 (180 sec.)

DATA MONITOR

Operation Procedure

1. Touch "HEADLAMP" on "SELECT TEST ITEM" screen.
2. Touch "DATA MONITOR" on "SELECT DIAG MODE" screen.
3. Touch either "ALL SIGNALS" or "SELECTION FROM MENU" on the "DATA MONITOR" screen.

All signals	Monitors all the signals.
Selection from menu	Selects and monitors individual signal.

4. Touch "START".
5. When "SELECTION FROM MENU" is selected, touch individual items to be monitored. When "ALL SIGNALS" is selected, all the items will be monitored.
6. Touch "RECORD" while monitoring, then the status of the monitored item can be recorded. To stop recording, touch "STOP".

Display Item List

Monitor item	Contents
IGN ON SW "ON/OFF"	Displays "IGN position (ON)/OFF, ACC position (OFF)" judged from the ignition switch signal.
ACC ON SW "ON/OFF"	Displays "ACC (ON)/OFF, Ignition OFF (OFF)" status judged from ignition switch signal.

AUTO LIGHT SYSTEM

Monitor item	Contents
HI BEAM SW "ON/OFF"	Displays status (high beam switch: ON/Others: OFF) of high beam switch judged from lighting switch signal.
HEAD LAMP SW 1 "ON/OFF"	Displays status (headlamp switch 1: ON/Others: OFF) of headlamp switch 2 judged from lighting switch signal.
HEAD LAMP SW 2 "ON/OFF"	Displays status (headlamp switch 2: ON/Others: OFF) of headlamp switch 2 judged from lighting switch signal.
TAIL LAMP SW "ON/OFF"	Displays status (lighting switch 1st position: ON/Others: OFF) of lighting switch judged from lighting switch signal.
AUTO LIGHT SW "ON/OFF"	Displays status of the lighting switch as judged from the lighting switch signal. (AUTO position: ON/Other than AUTO position: OFF)
PASSING SW "ON/OFF"	Displays status (flash-to-pass switch: ON/Others: OFF) of flash-to-pass switch judged from lighting switch signal.
FR FOG SW "ON/OFF"	Displays status (front fog lamp switch: ON/Others: OFF) of front fog lamp switch judged from lighting switch signal.
DOOR SW - DR "ON/OFF"	Displays status of the driver door as judged from the driver door switch signal. (Door is open: ON/Door is closed: OFF)
DOOR SW - AS "ON/OFF"	Displays status of the passenger door as judged from the passenger door switch signal. (Door is open: ON/Door is closed: OFF)
DOOR SW - RR "ON/OFF"	Displays status of the rear door as judged from the rear door switch (RH) signal. (Door is open: ON/Door is closed: OFF)
DOOR SW - RL "ON/OFF"	Displays status of the rear door as judged from the rear door switch (LH) signal. (Door is open: ON/Door is closed: OFF)
BACK DOOR SW "ON/OFF"	Displays status of the back door as judged from the back door switch signal. (Door is open: ON/Door is closed: OFF)
TURN SIGNAL R "ON/OFF"	Displays status (Turn right: ON/Others: OFF) as judged from lighting switch signal.
TURN SIGNAL L "ON/OFF"	Displays status (Turn left: ON/Others: OFF) as judged from lighting switch signal.
CARGO LAMP SW "ON/OFF"	Displays status of cargo lamp.
OPTICAL SENSOR [0 - 5V]	Displays "ambient light (close to 5V when dark/close to 0V when light)" judged from optical sensor signal.

ACTIVE TEST

Operation Procedure

1. Touch "HEADLAMP" on "SELECT TEST ITEM" screen.
2. Touch "ACTIVE TEST" on "SELECT DIAG MODE" screen.
3. Touch item to be tested and check operation of the selected item.
4. During the operation check, touching "BACK" deactivates the operation.

Display Item List

Test item	Description
TAIL LAMP	Allows tail lamp relay to operate by switching ON-OFF.
HEAD LAMP (LO)	Allows headlamp relay to operate by switching ON-OFF.
HEAD LAMP (HI)	Allows headlamp relay to operate by switching ON-OFF.
FR FOG LAMP	Allows fog lamp relay to operate by switching ON-OFF.
CARGO LAMP	Allows cargo lamp to operate by switching ON-OFF.

SELF-DIAGNOSTIC RESULTS

Operation Procedure

1. Touch "BCM C/U" on "SELECT TEST ITEM" screen.
2. Touch "SELF-DIAG RESULTS" on "SELECT DIAG MODE" screen.
3. Self-diagnostic results are displayed.

AUTO LIGHT SYSTEM

Display Item List

Monitored item	CONSULT-II display	Description
CAN communication	CAN communication [U1000]	Malfunction is detected in CAN communication.
CAN communication system	CAN communication system 1 to 6 [U1000]	Malfunction is detected in CAN system.

CONSULT-II Functions (IPDM E/R)

EKS0074E

CONSULT-II can display each diagnostic item using the diagnostic test modes shown following.

Inspection Item, Diagnosis Mode	Description
DATA MONITOR	The input/output data of the IPDM E/R is displayed in real time.
CAN DIAG SUPPORT MNTR	The result of transmit/receive diagnosis of CAN communication can be read.
ACTIVE TEST	The IPDM E/R sends a drive signal to electronic components to check their operation.

CONSULT-II OPERATION

CAUTION:

If CONSULT-II is used with no connection of CONSULT-II CONVERTER, malfunctions might be detected in self-diagnosis depending on control unit which carries out CAN communication.

1. With the ignition switch OFF, connect CONSULT-II and CONSULT-II CONVERTER to the data link connector, then turn the ignition switch ON.

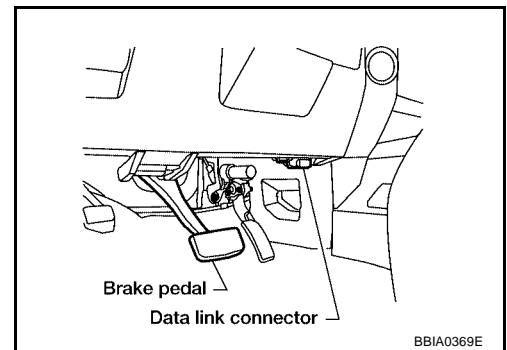

2. Touch "START (NISSAN BASED VHCL)".

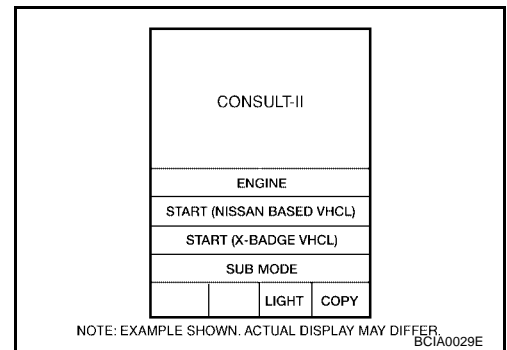

3. Touch "IPDM E/R" on "SELECT SYSTEM" screen. If "IPDM E/R" is not displayed, refer to [GI-38, "CONSULT-II Data Link Connector \(DLC\) Circuit"](#).

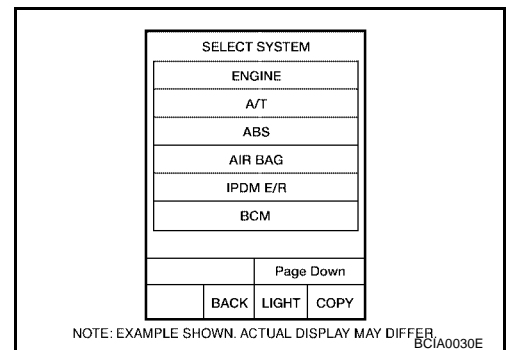

AUTO LIGHT SYSTEM

- Select the desired part to be diagnosed on the “SELECT DIAG MODE” screen.

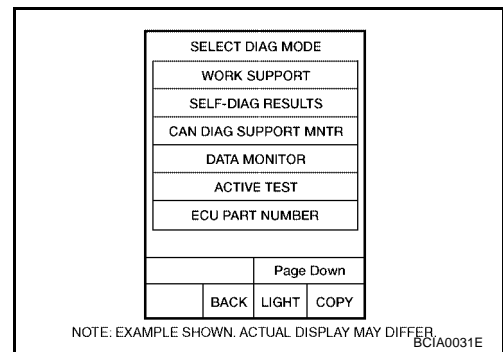

DATA MONITOR

Operation Procedure

- Touch “DATA MONITOR” on “SELECT DIAG MODE ” screen.
- Touch “ALL SIGNALS”, “MAIN SIGNALS” or “SELECT FROM MENU” on the “DATA MONITOR” screen.

ALL SIGNALS	All items will be monitored.
MAIN SIGNALS	Monitor the predetermined item.
SELECT FROM MENU	Select any item for monitoring.

- Touch “START”.
- Touch the required monitoring item on “SELECT ITEM MENU”. In “ALL SIGNALS”, all items are monitored. In “MAIN SIGNALS”, predetermined items are monitored.
- Touch “RECORD” while monitoring to record the status of the item being monitored. To stop recording, touch “STOP”.

All Items, Main Items, Select Item Menu

Item name	CONSULT-II screen display	Display or unit	Monitor item selection			Description
			ALL SIGNALS	MAIN SIGNALS	SELECT FROM MENU	
Position lights request	TAIL&CLR REQ	ON/OFF	×	×	×	Signal status input from BCM
Headlamp low beam request	HL LO REQ	ON/OFF	×	×	×	Signal status input from BCM
Headlamp high beam request	HL HI REQ	ON/OFF	×	×	×	Signal status input from BCM
Front fog lights request	FR FOG REQ	ON/OFF	×	×	×	Signal status input from BCM

NOTE:

Perform monitoring of IPDM E/R data with the ignition switch ON. When the ignition switch is at ACC, the display may not be correct.

ACTIVE TEST

Operation Procedure

- Touch “ACTIVE TEST” on “SELECT DIAG MODE” screen.
- Touch item to be tested, and check operation.
- Touch “START”.
- Touch “STOP” while testing to stop the operation.

AUTO LIGHT SYSTEM

Test item	CONSULT-II screen display	Description
Headlamp relay (HI, LO) output	LAMPS	Allows headlamp relay (HI, LO) to operate by switching operation (OFF, HI ON, LO ON) at your option (Headlamp high beam repeats ON-OFF every 1 second).
Front fog lamp relay output		Allows fog lamp relay to operate by switching operation ON-OFF at your option.
Tail lamp relay output	TAIL LAMP	Allows tail lamp relay to operate by switching operation ON-OFF at your option.

Trouble Diagnosis Chart by Symptom

EKS0074F

Trouble phenomenon	Malfunction system and reference
<ul style="list-style-type: none"> ● Parking lamps and headlamps will not illuminate when outside of the vehicle becomes dark. (Lighting switch 1st position and 2nd position operate normally.) ● Parking lamps and headlamp will not go out when outside of the vehicle becomes light. (Lighting switch 1st position and 2nd position operate normally.) ● Headlamps go out when outside of the vehicle becomes light, but parking lamps stay on. 	<ul style="list-style-type: none"> ● Refer to LT-61, "WORK SUPPORT" . ● Refer to LT-65, "Lighting Switch Inspection" . ● Refer to LT-66, "Optical Sensor System Inspection" . <p>If above systems are normal, replace BCM.</p>
Parking lamps illuminate when outside of the vehicle becomes dark, but headlamps stay off. (Lighting switch 1st position and 2nd position operate normally.)	<ul style="list-style-type: none"> ● Refer to LT-61, "WORK SUPPORT" . ● Refer to LT-66, "Optical Sensor System Inspection" . <p>If above systems are normal, replace BCM.</p>
Auto light adjustment system will not operate. (Lighting switch AUTO, 1st position and 2nd position operate normally.)	<ul style="list-style-type: none"> ● Refer to LT-66, "Optical Sensor System Inspection" . <p>If above system is normal, replace BCM.</p>
Auto light adjustment system will not operate.	<ul style="list-style-type: none"> ● CAN communication line to BCM inspection. Refer to BCS-13, "CAN Communication Inspection Using CONSULT-II (Self-Diagnosis)" .
Shut off delay feature will not operate.	<ul style="list-style-type: none"> ● CAN communication line inspection between BCM and combination meter. Refer to BCS-13, "CAN Communication Inspection Using CONSULT-II (Self-Diagnosis)" . ● Refer to BL-35, "Door Switch Check (King Cab)" . <p>If above system is normal, replace BCM.</p>

Lighting Switch Inspection

EKS0074G

1. CHECK LIGHTING SWITCH INPUT SIGNAL

Ⓟ With CONSULT-II
 Select "BCM" on CONSULT-II. With "HEAD LAMP" data monitor, make sure "AUTO LIGHT SW" turns ON-OFF linked with operation of lighting switch.

When lighting switch is in AUTO position : AUTO LIGHT SW ON

⊗ Without CONSULT-II
 Refer to [LT-99, "Combination Switch Inspection"](#) .

OK or NG

- OK >> INSPECTION END.
- NG >> Check lighting switch. Refer to [LT-99, "Combination Switch Inspection"](#) .

DATA MONITOR	
MONITOR	
AUTO LIGHT SW	ON

SKIA4196E

AUTO LIGHT SYSTEM

EKS0074H

Optical Sensor System Inspection

1. CHECK OPTICAL SENSOR INPUT SIGNAL

④ With CONSULT-II

Select "BCM" on CONSULT-II. With "OPTICAL SENSOR" data monitor, check difference in the voltage when the optical sensor is illuminated and not illuminated.

Illuminated

OPTICAL SENSOR : 3.0V or less

Not illuminated

OPTICAL SENSOR : 3.1V or more

NOTE:

Optical sensor must be completely subjected to work lamp light. If the optical sensor is insufficiently illuminated, the measured value may not satisfy the standard.

⊗ Without CONSULT-II

GO TO 2.

OK or NG

OK >> INSPECTION END.

NG >> GO TO 2.

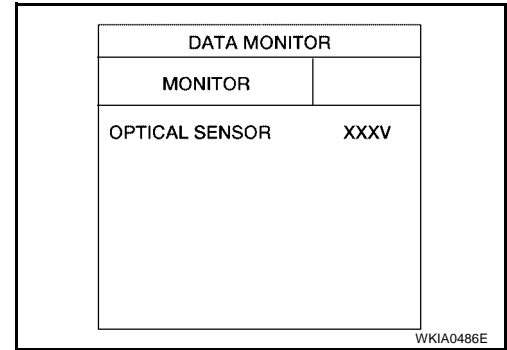

WKIA0486E

2. CHECK OPTICAL SENSOR SIGNAL GROUND CIRCUIT

1. Turn ignition switch OFF.
2. Disconnect BCM connector and optical sensor connector.
3. Check continuity (open circuit) between BCM harness connector M18 terminal 18 (P) and optical sensor harness connector M402 terminal 3 (P).

18 (P) – 3 (P) : Continuity should exist.

4. Check continuity (short circuit) between BCM harness connector M18 terminal 18 (P) and ground.

18 (P) – Ground : Continuity should not exist.

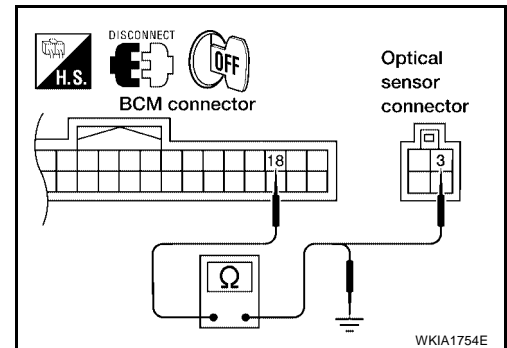

WKIA1754E

OK or NG

OK >> GO TO 3.

NG >> Repair harness or connector.

3. CHECK OPTICAL SENSOR SIGNAL CIRCUIT

1. Check continuity (open circuit) between BCM harness connector M20 terminal 58 (W/R) and optical sensor harness connector M402 terminal 4 (W/R).

58 (W/R) – 4 (W/R) : Continuity should exist.

2. Check continuity (short circuit) between BCM harness connector M20 terminal 58 (W/R) and ground.

58 (W/R) – Ground : Continuity should not exist.

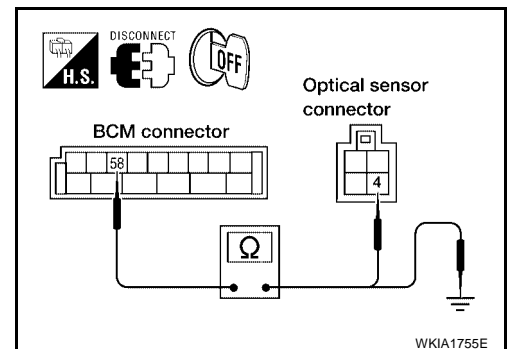

WKIA1755E

OK or NG

OK >> Replace optical sensor. Refer to [LT-67, "Removal and Installation of Optical Sensor"](#). Recheck sensor output with CONSULT-II. If NG, replace BCM. Refer to [BCS-25, "Removal and Installation of BCM"](#).

NG >> Repair harness or connector.

AUTO LIGHT SYSTEM

Removal and Installation of Optical Sensor

EKS0074I

REMOVAL

1. Remove defrost grille. Refer to [IP-10, "INSTRUMENT PANEL ASSEMBLY"](#) .
2. Disconnect the connector.
3. Turn the optical sensor counterclockwise to remove it from defroster grille.

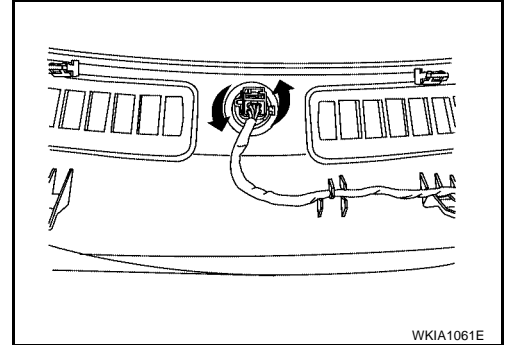

INSTALLATION

Installation is in the reverse order of removal.

A
B
C
D
E
F
G
H
I
J
LT
L
M

FRONT FOG LAMP

FRONT FOG LAMP

PF2:26150

Component Parts and Harness Connector Location

EKS0074J

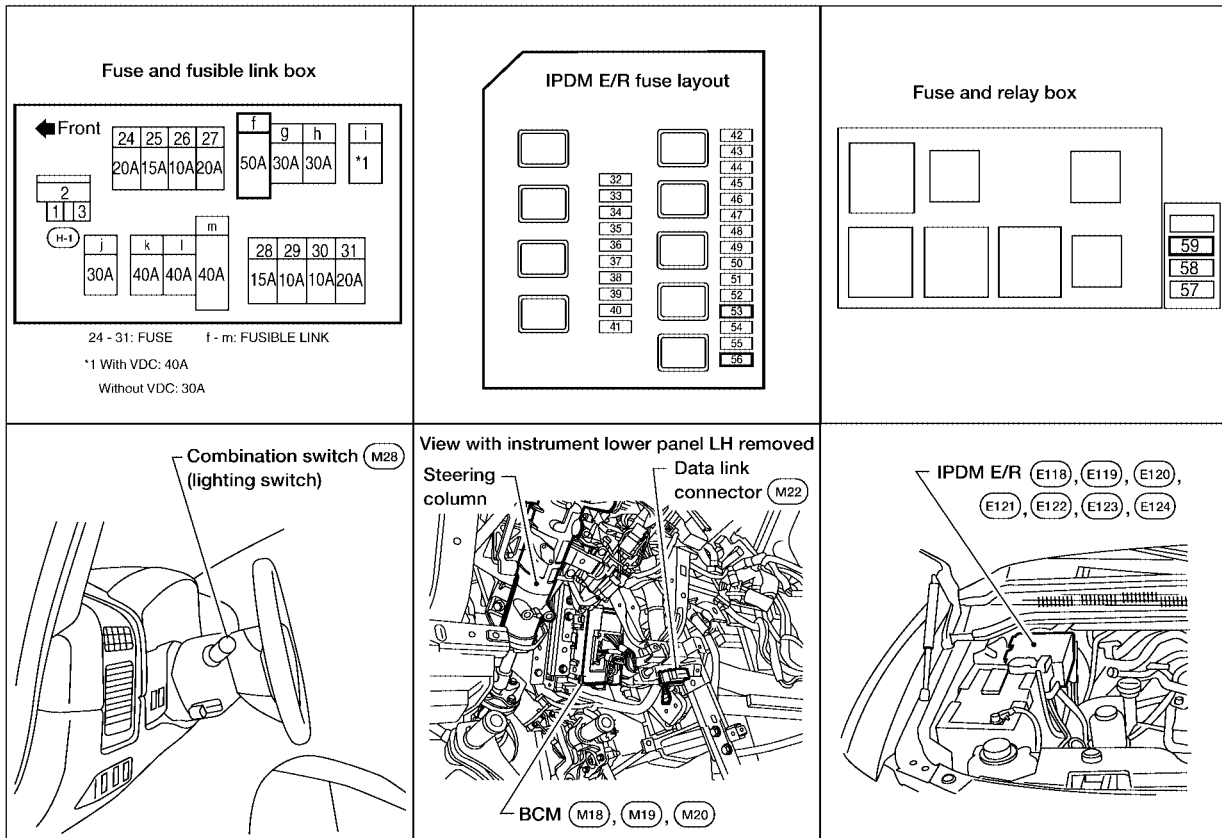

WKIA1756E

FRONT FOG LAMP

EKS0074K

System Description

Control of the fog lamps is dependent upon the position of the combination switch (lighting switch). The lighting switch must be in the 2ND position or AUTO position (LOW beam is ON) for front fog lamp operation. When the lighting switch is placed in the fog lamp position, the BCM (body control module) receives input signal requesting the fog lamps to illuminate. When the headlamps are illuminated, this input signal is communicated to the IPDM E/R (intelligent power distribution module engine room) across the CAN communication lines. The central processing unit of the IPDM E/R controls the front fog lamp relay coil. When activated, this relay directs power to the front fog lamps.

OUTLINE

Power is supplied at all times

- to front fog lamp relay, located in the IPDM E/R, and
- through 20A fuse (No. 53, located in the IPDM E/R)
- to CPU (central processing unit) in the IPDM E/R.

Power is also supplied at all times

- to BCM terminal 70
- through 50A fusible link (letter f , located in the fuse and fusible link box).

When the ignition switch is in ON or START position, power is supplied

- to ignition relay, located in the IPDM E/R, and
- through 10A fuse (No. 59, located in the fuse and relay box)
- to BCM terminal 38.

Ground is supplied at all times

- to BCM terminal 67
- through grounds M57, M61 and M79
- to IPDM E/R terminals 38 and 59
- through grounds E9, E15 and E24.

FOG LAMP OPERATION

The fog lamp switch is built into the combination switch. The lighting switch must be in the 2ND position or AUTO position (LOW beam is ON) and the fog lamp switch must be ON for fog lamp operation.

With the fog lamp switch in the ON position, the CPU (central processing unit) of the IPDM E/R grounds the coil side of the fog lamp relay. The fog lamp relay then directs power

- through 20A fuse (No. 56, located in the IPDM E/R)
- through IPDM E/R terminal 50
- to front fog lamp LH terminal +
- through IPDM E/R terminal 51
- to front fog lamp RH terminal +.

Ground is supplied at all times

- to front fog lamp LH and RH terminal -
- through grounds E9, E15 and E24.

With power and grounds supplied, the front fog lamps illuminate.

COMBINATION SWITCH READING FUNCTION

Refer to [LT-97, "Combination Switch Reading Function"](#) .

EXTERIOR LAMP BATTERY SAVER CONTROL

When the combination switch (lighting switch) is in the 2ND position (ON), the fog lamp switch is ON, and the ignition switch is turned from ON or ACC to OFF, the battery saver control feature is activated.

Under this condition, the fog lamps (and headlamps) remain illuminated for 5 minutes, then the fog lamps (and headlamps) are turned off.

Exterior lamp battery saver control mode can be changed by the function setting of CONSULT-II.

CAN Communication System Description

EKS0074L

Refer to [LAN-8, "CAN COMMUNICATION"](#) .

FRONT FOG LAMP

EKS0074M

Wiring Diagram — F/FOG —

LT-F/FOG-01

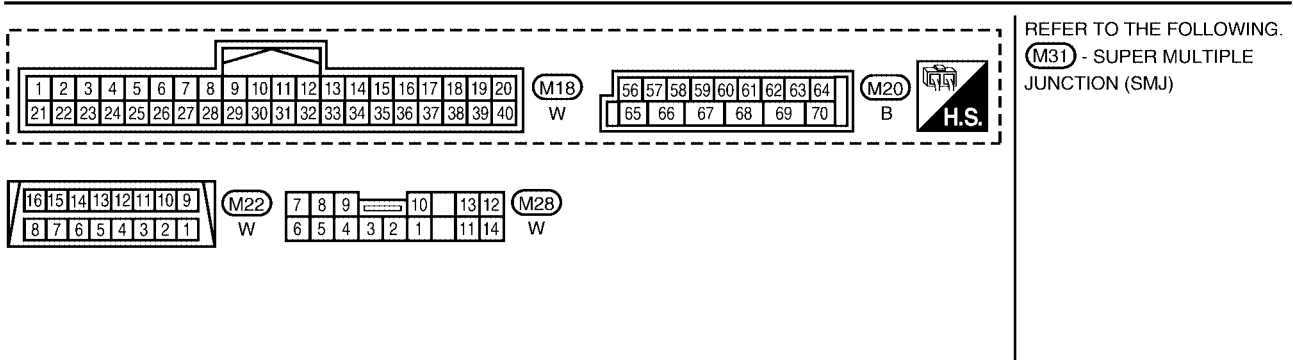
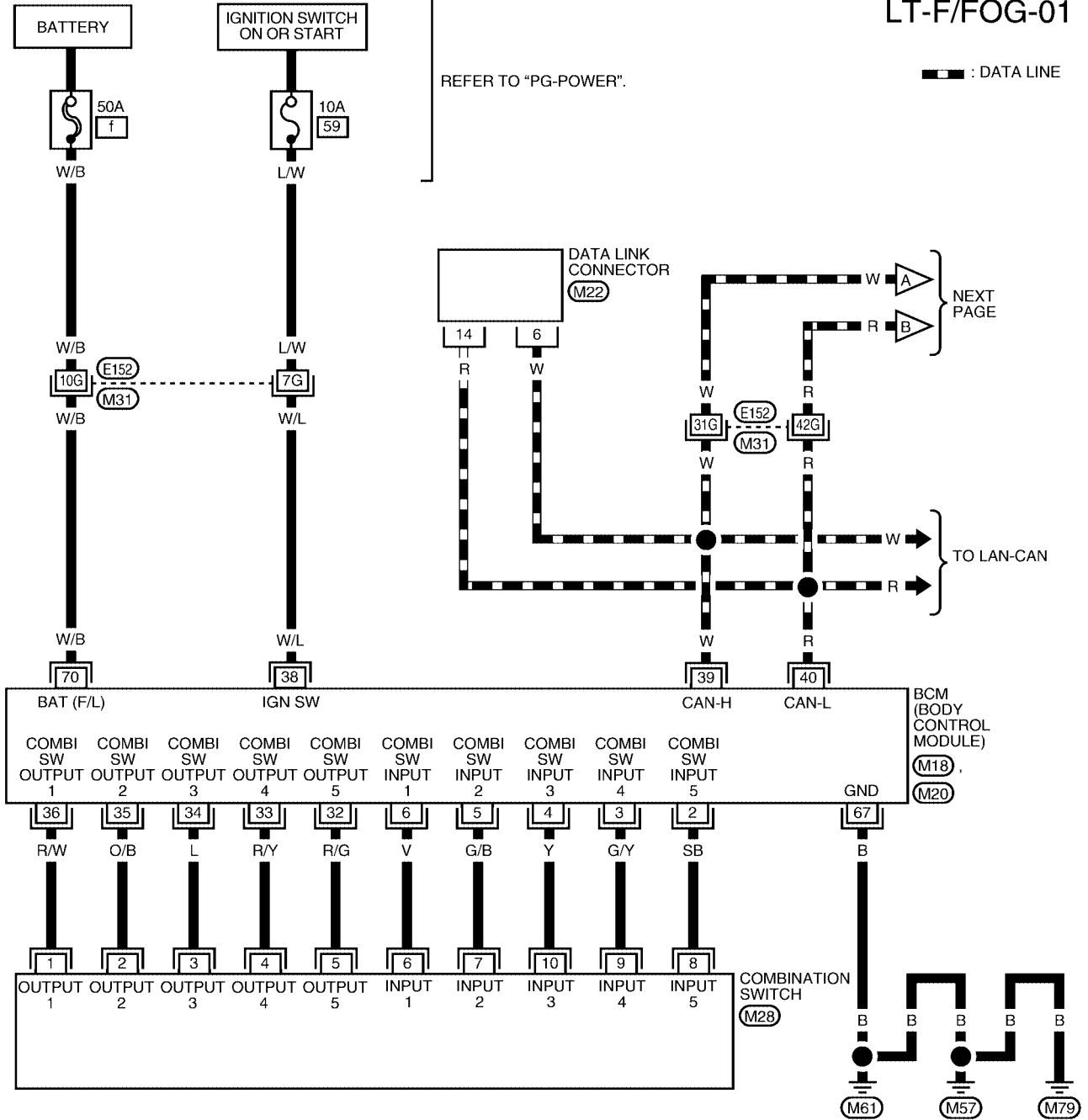

WKWA1157E

FRONT FOG LAMP

LT-F/FOG-02

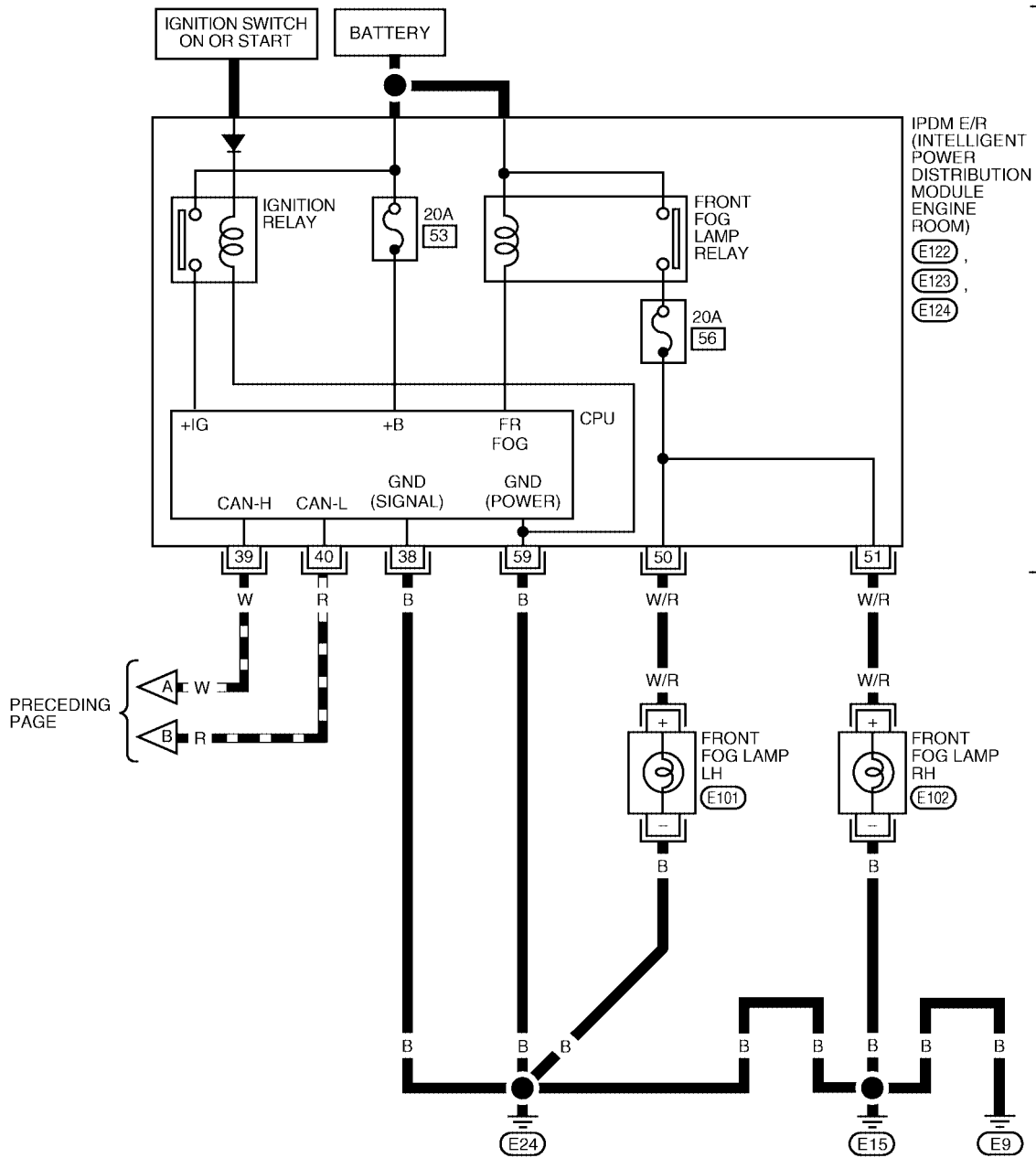

PRECEDING PAGE

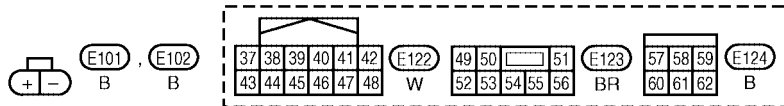

WKWA1479E

FRONT FOG LAMP

Terminals and Reference Value for BCM

EKS0074N

Terminal No.	Wire color	Signal name	Measuring condition		Reference value (Approx.)
			Ignition switch	Operation or condition	
2	SB	Combination switch input 5	ON	Lighting, turn, wiper OFF Wiper dial position 4	<p style="text-align: right;">SKIA5291E</p>
3	G/Y	Combination switch input 4	ON	Lighting, turn, wiper OFF Wiper dial position 4	<p style="text-align: right;">SKIA5292E</p>
4	Y	Combination switch input 3	ON	Lighting, turn, wiper OFF Wiper dial position 4	<p style="text-align: right;">SKIA5291E</p>
5	G/B	Combination switch input 2	ON	Lighting, turn, wiper OFF Wiper dial position 4	<p style="text-align: right;">SKIA5292E</p>
6	V	Combination switch input 1			
32	R/G	Combination switch output 5	ON	Lighting, turn, wiper OFF Wiper dial position 4	<p style="text-align: right;">SKIA5291E</p>
33	R/Y	Combination switch output 4	ON	Lighting, turn, wiper OFF Wiper dial position 4	<p style="text-align: right;">SKIA5292E</p>
34	L	Combination switch output 3	ON	Lighting, turn, wiper OFF Wiper dial position 4	<p style="text-align: right;">SKIA5291E</p>

FRONT FOG LAMP

Terminal No.	Wire color	Signal name	Measuring condition		Reference value (Approx.)
			Ignition switch	Operation or condition	
35	O/B	Combination switch output 2	ON	Lighting, turn, wiper OFF Wiper dial position 4	
36	R/W	Combination switch output 1			
38	W/L	Ignition switch (ON)	ON	—	Battery voltage
39	W	CAN- H	—	—	—
40	R	CAN- L	—	—	—
67	B	Ground	ON	—	0V
70	W/B	Battery power supply (fusible link)	OFF	—	Battery voltage

Terminals and Reference Values for IPDM E/R

EKS00740

Terminal No.	Wire color	Signal name	Measuring condition		Reference value (Approx.)	
			Ignition switch	Operation or condition		
38	B	Ground	ON	—	0V	
39	W	CAN- H	—	—	—	
40	R	CAN- L	—	—	—	
50	W/R	Front fog lamp (LH)	ON	Lighting switch must be in the 2ND position or AUTO position (LOW beam is ON) and the front fog lamp switch must be ON	OFF	0V
					ON	Battery voltage
51	W/R	Front fog lamp (RH)	ON	Lighting switch must be in the 2ND position or AUTO position (LOW beam is ON) and the front fog lamp switch must be ON	OFF	0V
						ON
59	B	Ground	ON	—	0V	

How to Proceed With Trouble Diagnosis

EKS0074P

1. Confirm the symptom or customer complaint.
2. Understand operation description and function description. Refer to [LT-69, "System Description"](#) .
3. Perform the Preliminary Check. Refer to [LT-74, "Preliminary Check"](#) .
4. Check symptom and repair or replace the cause of malfunction.
5. Does the front fog lamp operate normally? If YES: GO TO 6. If NO: GO TO 4.
6. INSPECTION END.

FRONT FOG LAMP

EKS0074Q

Preliminary Check CHECK BCM CONFIGURATION

1. CHECK BCM CONFIGURATION

Confirm BCM configuration for "FR FOG LAMP" is set to "WITH". Refer to [BCS-13, "READ CONFIGURATION PROCEDURE"](#).

OK or NG

- OK >> Continue preliminary check. Refer to [LT-74, "CHECK POWER SUPPLY AND GROUND CIRCUIT"](#).
- NG >> Change BCM configuration for "FR FOG LAMP" to "WITH". Refer to [BCS-16, "WRITE CONFIGURATION PROCEDURE"](#).

CHECK POWER SUPPLY AND GROUND CIRCUIT

1. CHECK FUSES OR FUSIBLE LINK

Check for blown fuses or fusible link.

Unit	Power source	Fuse No.
BCM	Battery	f
	Ignition switch ON or START position	59
IPDM E/R	Battery	53
	Battery (Fog lamps ON)	56

Refer to [LT-70, "Wiring Diagram — F/FOG —"](#).

OK or NG

- OK >> GO TO 2.
- NG >> If fuse is blown, be sure to eliminate cause of malfunction before installing new fuse. Refer to [PG-4, "POWER SUPPLY ROUTING CIRCUIT"](#).

2. CHECK POWER SUPPLY CIRCUIT

1. Disconnect BCM connector.
2. Check voltage between BCM harness connector and ground.

Terminals		(-)	Ignition switch position		
(+)			OFF	ACC	ON
Connector	Terminal (Wire color)	Ground	0V	0V	Battery voltage
M18	38 (W/L)		Battery voltage	Battery voltage	Battery voltage
M20	70 (W/B)				

OK or NG

- OK >> GO TO 3.
- NG >> Check harness for open between BCM and fuse.

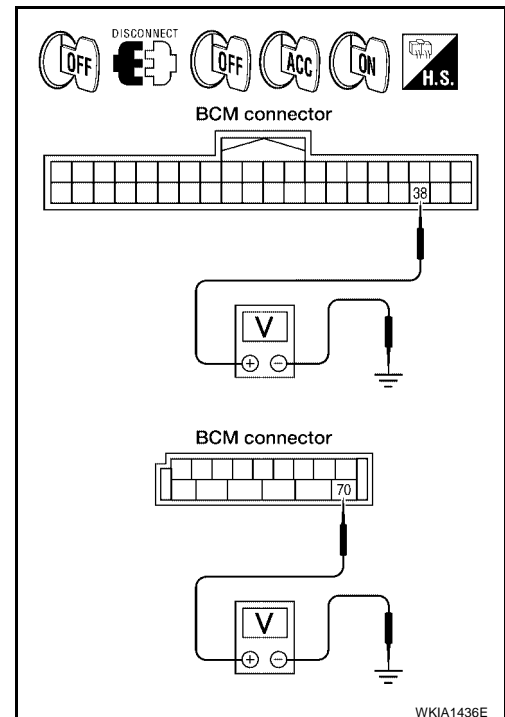

WKIA1436E

FRONT FOG LAMP

3. CHECK GROUND CIRCUIT

Check continuity between BCM harness connector and ground.

Terminals		(-)	Continuity
(+) Connector			
Connector	Terminal (Wire color)		
M20	67 (B)	Ground	Yes

OK or NG

- OK >> INSPECTION END.
- NG >> Check ground circuit harness.

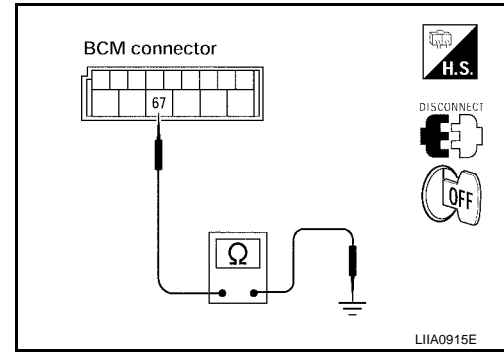

EKS0074R

CONSULT-II Functions

Refer to [LT-18, "CONSULT-II Functions \(BCM\)"](#) in HEADLAMP (FOR USA).

Refer to [LT-21, "CONSULT-II Functions \(IPDM E/R\)"](#) in HEADLAMP (FOR USA).

Front Fog Lamps Do Not Illuminate (Both Sides)

EKS0074S

1. CHECK COMBINATION SWITCH INPUT SIGNAL

Select "BCM" on CONSULT-II. With "HEAD LAMP" data monitor, make sure "FR FOG SW" turns ON-OFF linked with operation of lighting switch.

When lighting switch is in FOG position : FR FOG SW ON

OK or NG

- OK >> GO TO 2.
- NG >> Check lighting switch. Refer to [LT-99, "Combination Switch Inspection"](#).

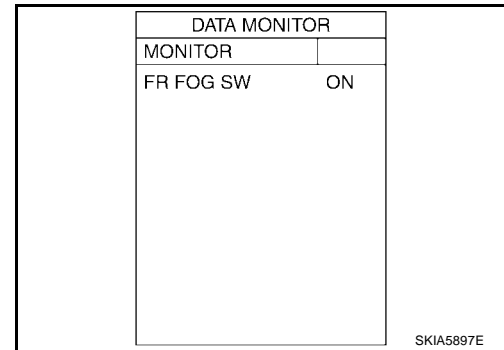

2. FOG LAMP ACTIVE TEST

1. Select "IPDM E/R" on CONSULT-II and select "ACTIVE TEST" on "SELECT DIAG MODE" screen.
2. Select "EXTERNAL LAMPS" on "SELECT TEST ITEM" screen.
3. Touch "FOG" screen.
4. Make sure fog lamps operate.

Fog lamps should operate.

OK or NG

- OK >> GO TO 3.
- NG >> GO TO 4.

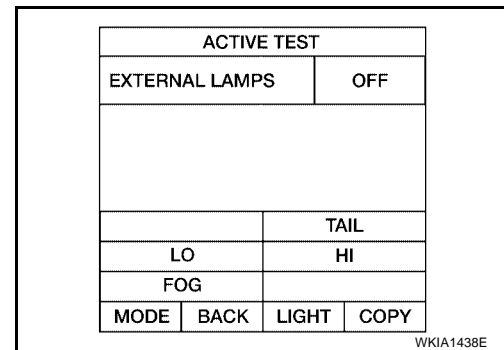

FRONT FOG LAMP

3. CHECK IPDM E/R

1. Select "IPDM E/R" on CONSULT-II and select "DATA MONITOR" on "SELECT DIAG MODE" screen.
2. Make sure "FR FOG REQ" turns ON when lighting switch is in FOG position.

When lighting switch is in FOG position : FR FOG REQ ON

OK or NG

- OK >> Replace IPDM E/R. Refer to [PG-28, "Removal and Installation of IPDM E/R"](#) .
- NG >> Replace BCM. Refer to [BCS-25, "Removal and Installation of BCM"](#) .

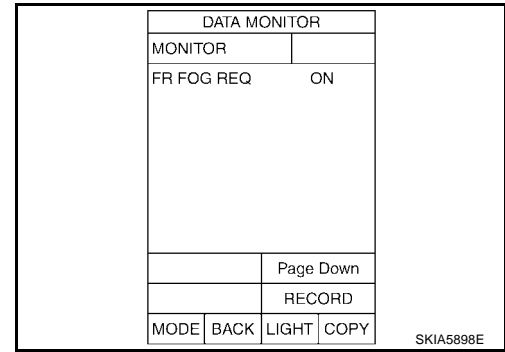

4. IPDM E/R INSPECTION

Start active test. Refer to [PG-22, "Auto Active Test"](#) . When front fog lamp relay is operating, check voltage between left/right front fog lamp connector terminals and body ground.

Terminals			Voltage (Approx.)
Front fog lamp			
Connector	Terminal (wire color)	Body ground (-)	
Left	E101 + (W/R)		
Right	E102 + (W/R)		

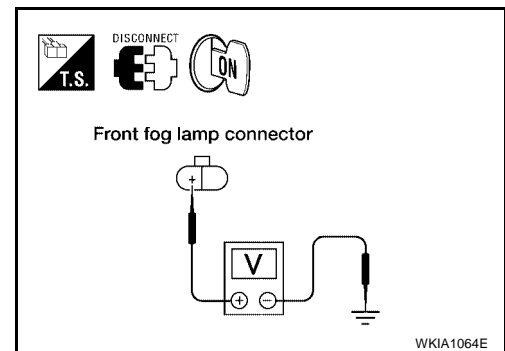

OK or NG

- OK >> Check front fog lamp bulbs and replace as necessary.
- NG >> Replace IPDM E/R. Refer to [PG-28, "Removal and Installation of IPDM E/R"](#) .

Front Fog Lamp Does Not Illuminate (One Side)

EKS0074T

1. BULB INSPECTION

Inspect bulbs of lamps which do not illuminate.

OK or NG

- OK >> GO TO 2.
- NG >> Replace lamp bulb.

2. INSPECTION BETWEEN IPDM E/R AND FRONT FOG LAMPS

1. Disconnect IPDM E/R connector and inoperative front fog lamp connector.
2. Check continuity between harness connector terminals of IPDM E/R and harness connector terminal of front fog lamps.

Terminals				Continuity
IPDM E/R		Front fog lamp		
Connector	Terminal (wire color)	Connector	Terminal (wire color)	
E123	50 (W/R)	Left	E101 + (W/R)	Yes
	51 (W/R)	Right	E102 + (W/R)	

OK or NG

- OK >> Check ground circuit. If OK, replace IPDM E/R. Refer to [PG-28, "Removal and Installation of IPDM E/R"](#) . If NG, repair harness or connector.
- NG >> Check for short circuits and open circuits in harness between IPDM E/R and front fog lamps.

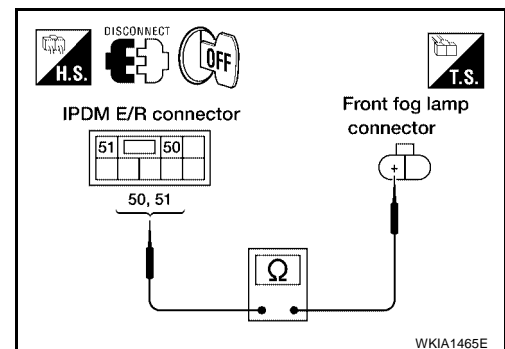

FRONT FOG LAMP

EKS0074U

Aiming Adjustment

The fog lamp is a semi-sealed beam type which uses a replaceable halogen bulb. Before performing aiming adjustment, make sure of the following.

- Keep all tires inflated to correct pressure.
- Place vehicle on level ground.
- See that vehicle is unloaded (except for full levels of coolant, engine oil and fuel, and spare tire, jack, and tools). Have the driver or equivalent weight placed in driver seat.

Adjust aiming in the vertical direction by turning the adjustment screw.

NOTE:

Access adjustment screw from underneath front bumper. Use a T-3 (3 mm) Torx® bit or a 3 mm allen wrench to adjust. Turn screw clockwise to raise pattern and counterclockwise to lower pattern.

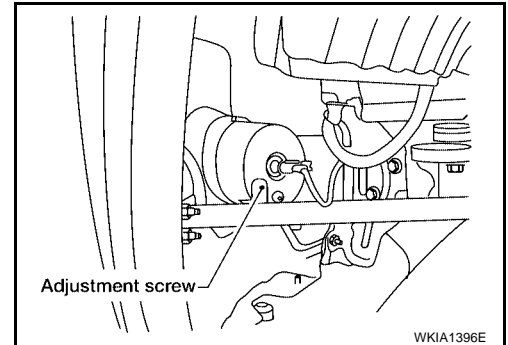

1. Set the distance between the screen and the center of the fog lamp lens as shown.
2. Turn front fog lamps ON.

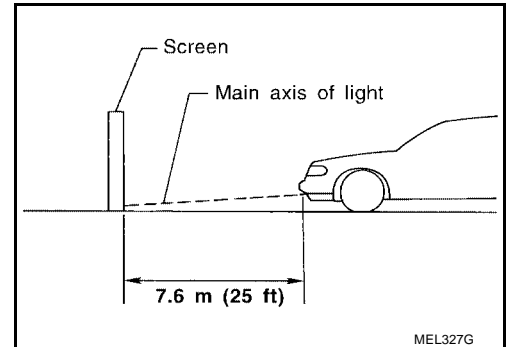

3. Adjust front fog lamps using adjusting screw so that the top edge of the high intensity zone is 100 mm (4 in) below the height of the fog lamp centers as shown.
- When performing adjustment, if necessary, cover the headlamps and opposite fog lamp.

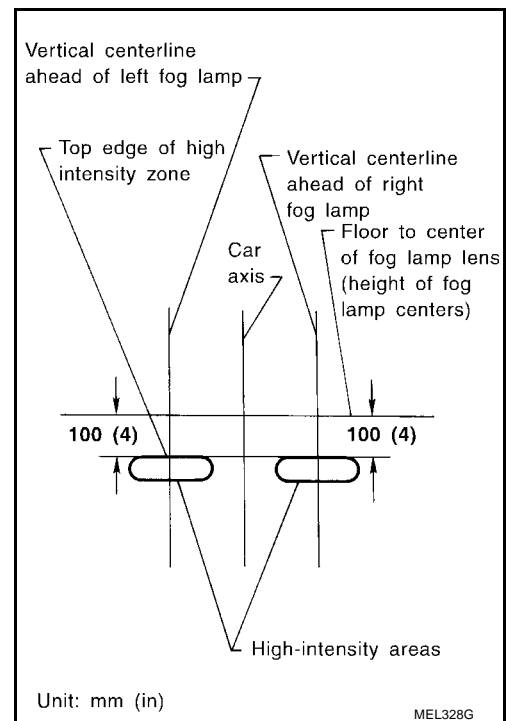

A
B
C
D
E
F
G
H
I
J
LT
L
M

FRONT FOG LAMP

Bulb Replacement

EKS0074V

1. Disconnect electrical connector.
2. Turn the bulb counterclockwise to remove it.

CAUTION:

- Do not touch the glass of bulb directly by hand. Keep grease and other oily substances away from it. Do not touch bulb by hand while it is lit or right after being turned off. Burning may result.
- Do not leave bulb out of fog lamp reflector for a long time because dust, moisture smoke, etc. may affect the performance of fog lamp. When replacing bulb, be sure to replace it with new one.

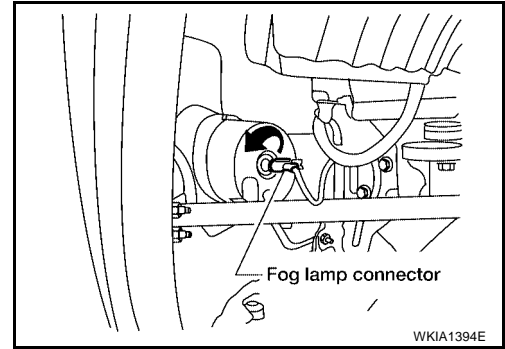

Removal and Installation

EKS0074W

The fog lamp is a semi-sealed beam type which uses a replaceable halogen bulb.

CAUTION:

- Do not leave fog lamp assembly without bulb for a long period of time. Dust, moisture, smoke, etc. entering the fog lamp body may affect the performance. Remove the bulb from the headlamp assembly just before replacement bulb is installed.
 - Grasp only the plastic base when handling the bulb. Never touch the glass envelope. Touching the glass could significantly affect the bulb life and/or fog lamp performance.
1. Position the fender protector aside.
 2. Disconnect electrical connector.
 3. Remove nut and pull fog lamp out of front fascia.

Installation is in the reverse order of removal.

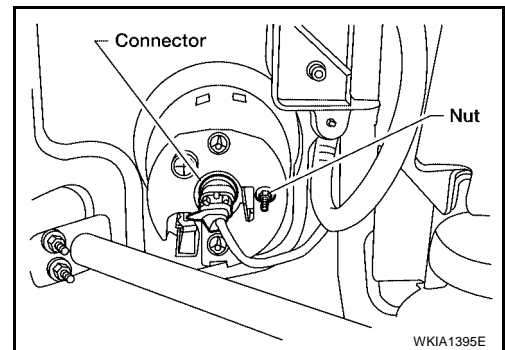

TURN SIGNAL AND HAZARD WARNING LAMPS

TURN SIGNAL AND HAZARD WARNING LAMPS

PF26120

Component Parts and Harness Connector Location

EKS0074X

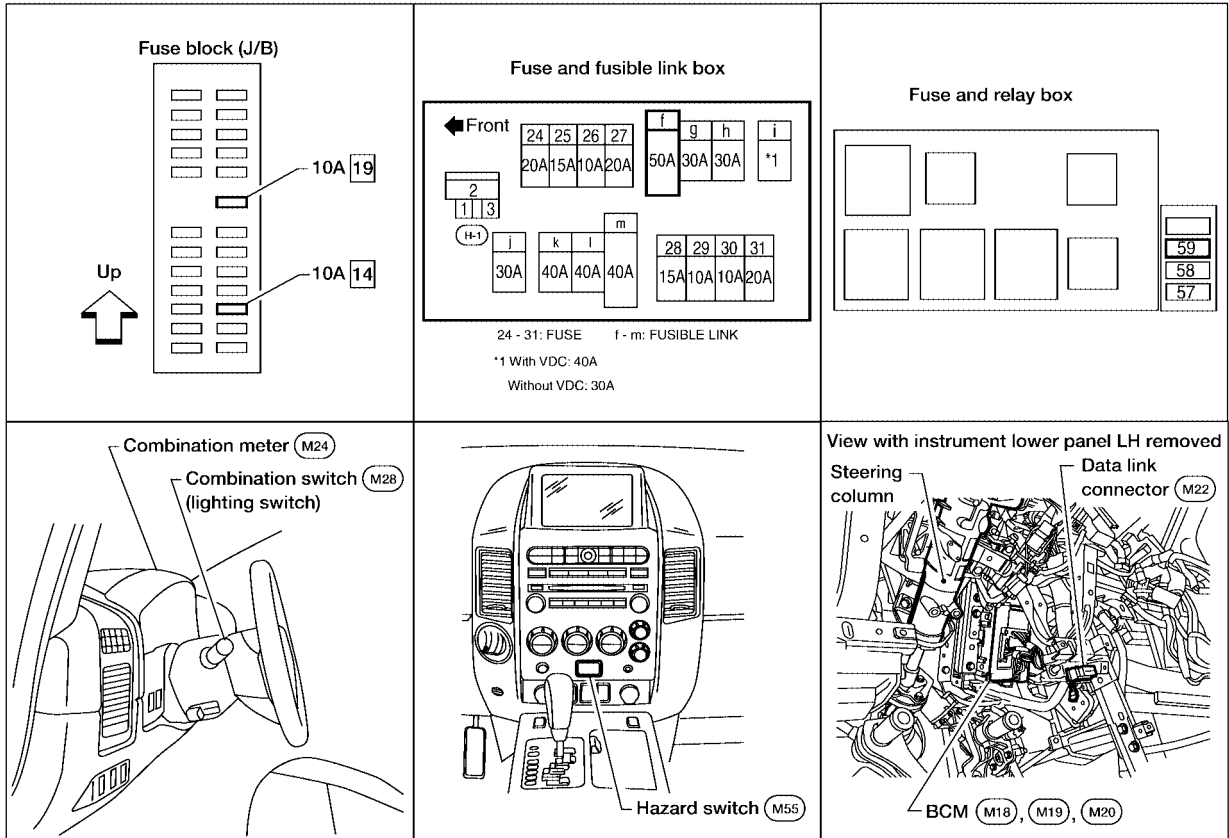

A
B
C
D
E
F
G
H
I
J
LT
L
M

TURN SIGNAL AND HAZARD WARNING LAMPS

EKS0074Y

System Description

OUTLINE

Power is supplied at all times

- through 50A fusible link (letter **f** , located in the fuse and fusible link box)
- to BCM (body control module) terminal 70
- through 10A fuse [No. 19, located in the fuse block (J/B)]
- to combination meter terminal 8.

TURN SIGNAL OPERATION

When the ignition switch is in the ON or START position, power is supplied

- through 10A fuse (No. 59, located in the fuse and relay box)
- to BCM terminal 38, and
- through 10A fuse [No. 14, located in the fuse block (J/B)]
- to combination meter terminal 24.

Ground is supplied

- to BCM terminal 67 and
- to combination meter terminal 17
- through grounds M57, M61 and M79.

LH Turn

When the turn signal switch is moved to the left position, BCM outputs turn signal from BCM terminal 60, interpreting it as turn signal is ON.

The BCM supplies power

- from terminal 60
- to front combination lamp LH terminal 5
- through front combination lamp LH terminal 4
- to grounds E9, E15 and E24, and
- to rear combination lamp LH terminal 8
- through rear combination lamp LH terminal 1
- to grounds E9, E15 and E24.

BCM sends signal to combination meter through CAN communication lines, and turns on turn signal indicator lamp within combination meter.

RH Turn

When the turn signal switch is moved to the right position, BCM outputs turn signal from BCM terminal 61, interpreting it as turn signal is ON.

The BCM supplies power

- from terminal 61
- to front combination lamp RH terminal 5
- through front combination lamp RH terminal 4
- to grounds E9, E15 and E24, and
- to rear combination lamp RH terminal 8
- through rear combination lamp terminal 1
- to grounds E9, E15 and E24.

BCM sends signal to combination meter through CAN communication lines, and turns on turn signal indicator lamp within combination meter.

HAZARD LAMP OPERATION

Power is supplied at all times

- through 50A fusible link (letter **f** , located in the fuse and fusible link box)
- to BCM terminal 70, and
- through 10A fuse [No. 19, located in the fuse block (J/B)]
- to combination meter terminal 8.

TURN SIGNAL AND HAZARD WARNING LAMPS

Ground is supplied

- through BCM terminal 67
- through combination meter terminal 17
- to grounds M57, M61 and M79.

When the hazard switch is depressed, ground is supplied

- to BCM terminal 29
- from hazard switch terminal 4
- through hazard switch terminal 6
- from grounds M57, M61 and M79.

When the hazard switch is depressed, BCM outputs turn signal from BCM terminals 60 and 61, interpreting it as turn signal is ON.

The BCM supplies power

- from terminals 60 and 61
- to front combination lamp LH and RH terminal 5
- through front combination lamp LH and RH terminal 4
- to grounds E9, E15 and E24, and
- to rear combination lamp LH and RH terminal 8
- through rear combination lamp LH and RH terminal 1
- to grounds E9, E15 and E24.

BCM sends signal to combination meter through CAN communication lines, and turns on turn signal indicator lamps within combination meter.

REMOTE KEYLESS ENTRY SYSTEM OPERATION

Power is supplied at all times

- through 50A fusible link (letter f , located in the fuse and fusible link box)
- to BCM terminal 70
- through 10A fuse [No. 19, located in the fuse block (J/B)]
- to combination meter terminal 8.

Ground is supplied

- to BCM terminal 67 and
- to combination meter terminal 17
- through grounds M57, M61 and M79.

When the remote keyless entry system is triggered by input from the key fob, BCM output turn signal from BCM terminals 60 and 61, interpreting it as turn signal is ON.

The BCM supplies power

- from terminals 60 and 61
- to front combination lamp LH and RH terminal 5
- through front combination lamp LH and RH terminal 4
- to grounds E9, E15 and E24, and
- to rear combination lamp LH and RH terminal 8
- through rear combination lamp LH and RH terminal 1
- to grounds E9, E15 and E24.

BCM sends signal to combination meter through CAN communication lines, and turns on turn signal indicator lamps within combination meter.

With power and input supplied, the BCM controls the flashing of the hazard warning lamps when key fob is used to activate the remote keyless entry system.

COMBINATION SWITCH READING FUNCTION

Refer to [LT-97, "Combination Switch Reading Function"](#) .

CAN Communication System Description

Refer to [LAN-8, "CAN COMMUNICATION"](#) .

A

B

C

D

E

F

G

H

I

J

LT

L

M

TURN SIGNAL AND HAZARD WARNING LAMPS

EKS00750

Wiring Diagram — TURN —

LT-TURN-01

— : DATA LINE

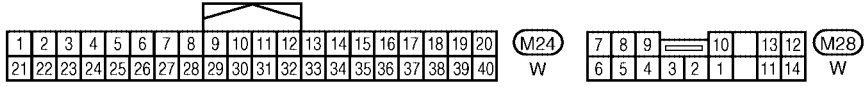
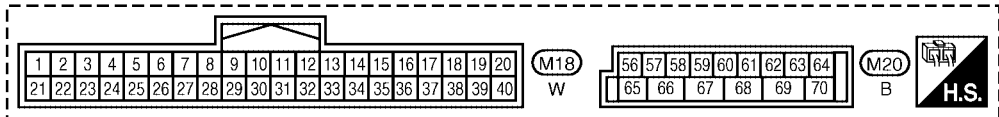
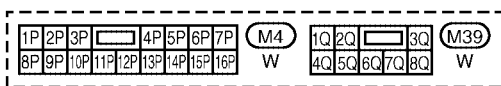
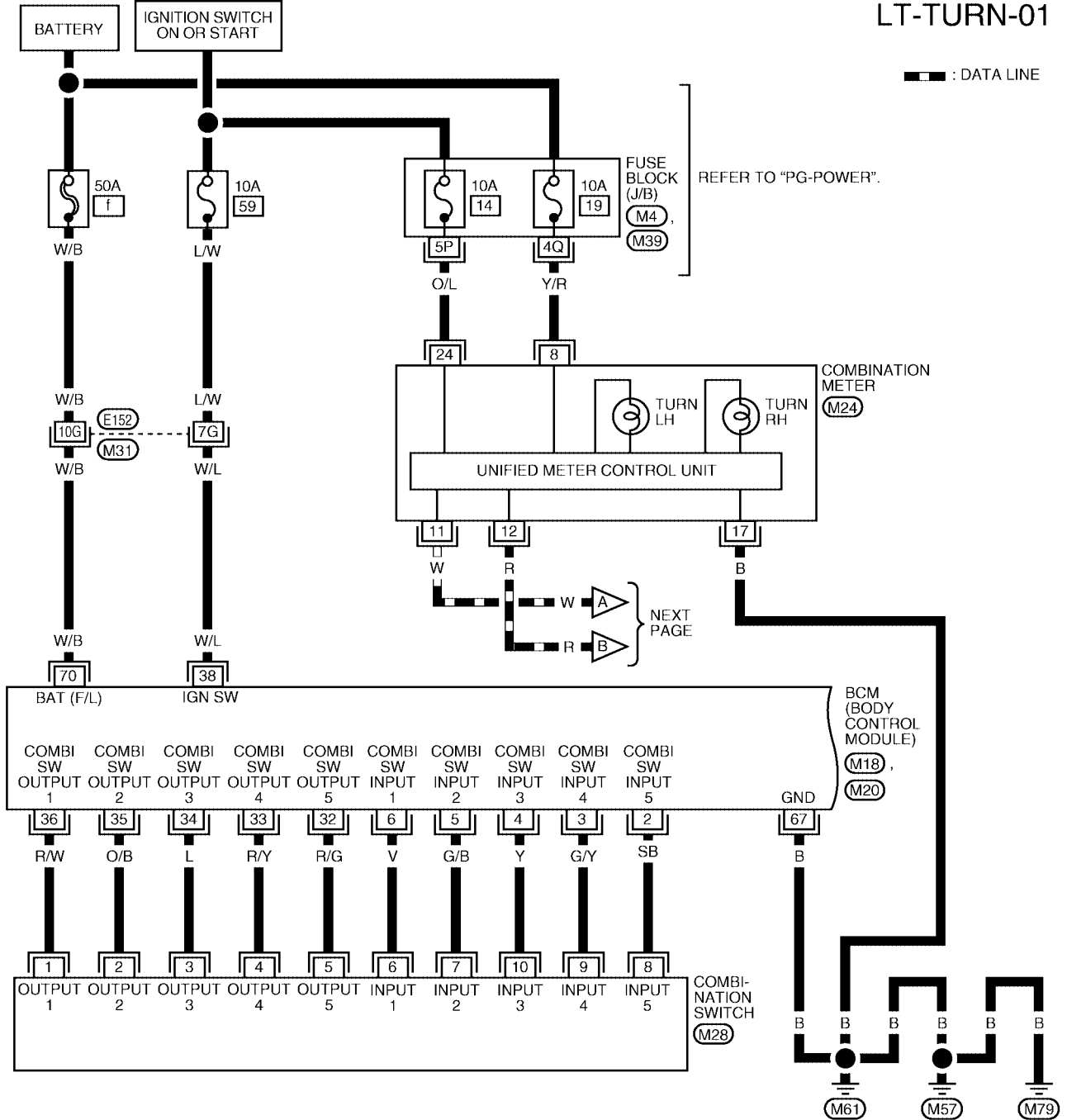

REFER TO THE FOLLOWING.
 (M31) - SUPER MULTIPLE JUNCTION (SMJ)

TURN SIGNAL AND HAZARD WARNING LAMPS

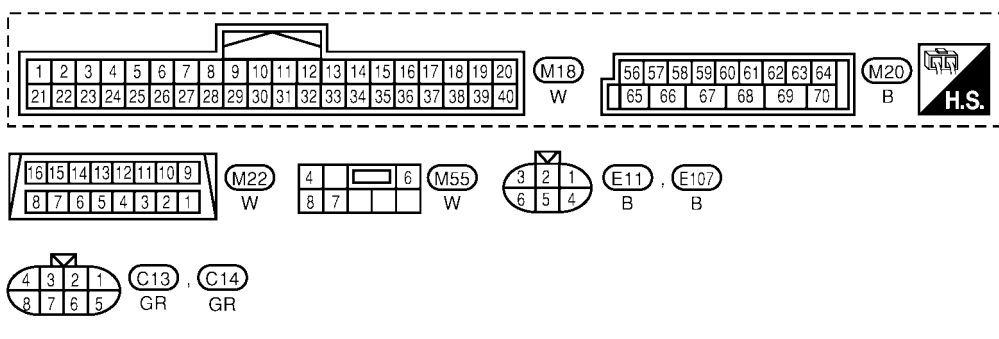
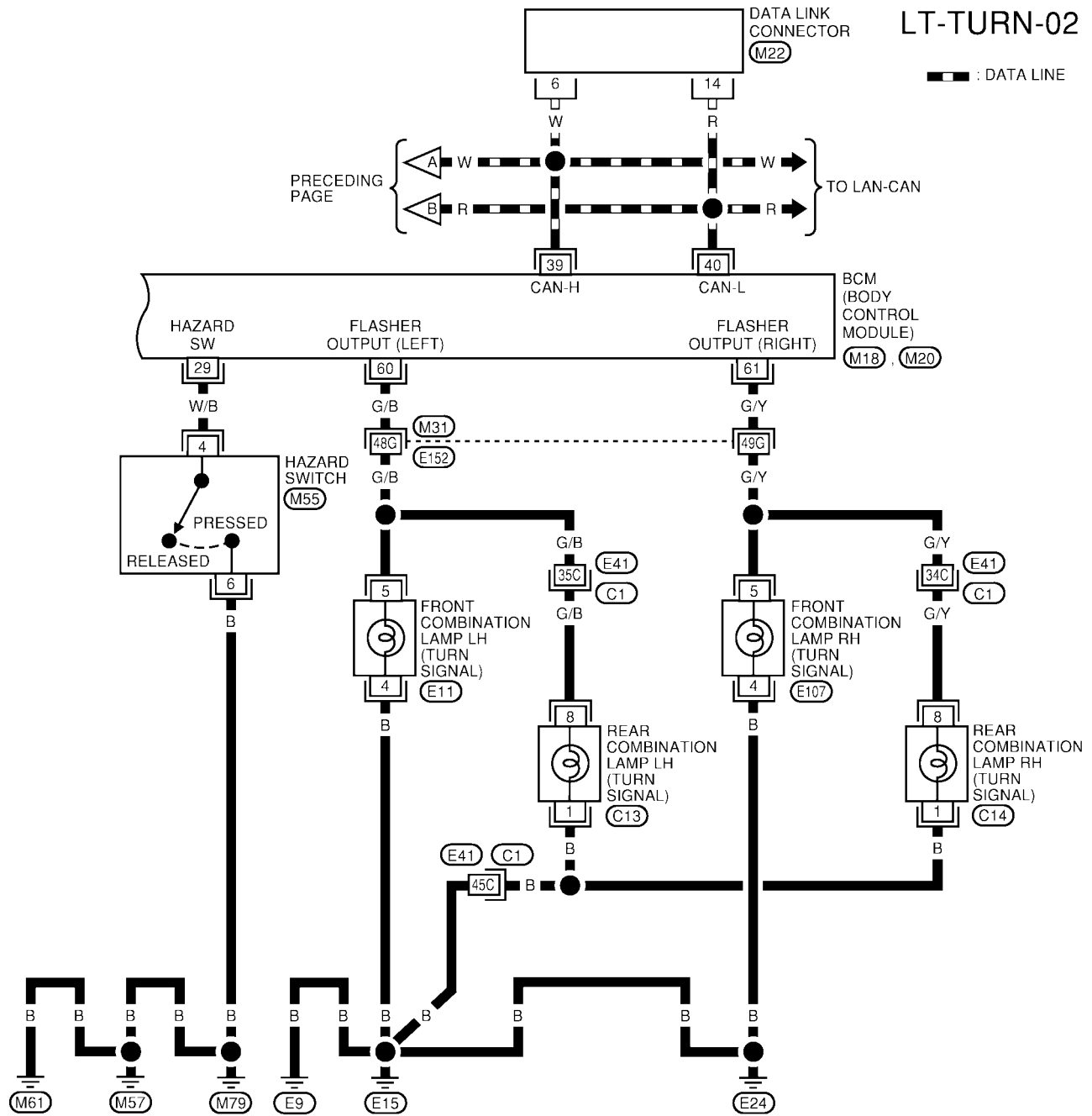





REFER TO THE FOLLOWING.
 (M31), (C1) - SUPER
 MULTIPLE JUNCTION (SMJ)

WKWA1509E

TURN SIGNAL AND HAZARD WARNING LAMPS

Terminals and Reference Value for BCM

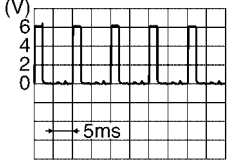
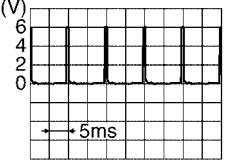
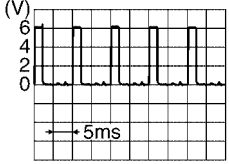
EKS00751

Terminal No.	Wire color	Signal name	Measuring condition		Reference value (Approx.)				
			Ignition switch	Operation or condition					
2	SB	Combination switch input 5	ON	Lighting, turn, wiper OFF Wiper dial position 4	 <p style="text-align: right;">SKIA5291E</p>				
3	G/Y	Combination switch input 4	ON	Lighting, turn, wiper OFF Wiper dial position 4	 <p style="text-align: right;">SKIA5292E</p>				
4	Y	Combination switch input 3	ON	Lighting, turn, wiper OFF Wiper dial position 4	 <p style="text-align: right;">SKIA5291E</p>				
5	G/B	Combination switch input 2	ON	Lighting, turn, wiper OFF Wiper dial position 4	 <p style="text-align: right;">SKIA5292E</p>				
6	V	Combination switch input 1							
29	W/B	Hazard switch signal	OFF	Hazard switch	<table border="1" style="width: 100%; border-collapse: collapse;"> <tr> <td style="width: 50%; text-align: center;">ON</td> <td style="text-align: center;">0V</td> </tr> <tr> <td style="width: 50%; text-align: center;">OFF</td> <td style="text-align: center;">5V</td> </tr> </table>	ON	0V	OFF	5V
ON	0V								
OFF	5V								
32	R/G	Combination switch output 5	ON	Lighting, turn, wiper OFF Wiper dial position 4	 <p style="text-align: right;">SKIA5291E</p>				
33	R/Y	Combination switch output 4	ON	Lighting, turn, wiper OFF Wiper dial position 4	 <p style="text-align: right;">SKIA5292E</p>				

TURN SIGNAL AND HAZARD WARNING LAMPS

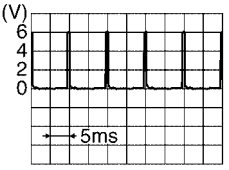
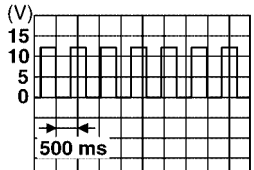
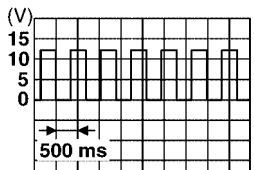
Terminal No.	Wire color	Signal name	Measuring condition		Reference value (Approx.)	
			Ignition switch	Operation or condition		
34	L	Combination switch output 3	ON	Lighting, turn, wiper OFF Wiper dial position 4	 SKIA5291E	
35	O/B	Combination switch output 2	ON	Lighting, turn, wiper OFF Wiper dial position 4	 SKIA5292E	
36	R/W	Combination switch output 1				
38	W/L	Ignition switch (ON)	ON	—	Battery voltage	
39	W	CAN-H	—	—	—	
40	R	CAN-L	—	—	—	
60	G/B	Turn signal (left)	ON	Combina- tion switch	Turn left ON	 SKIA3009J
61	G/Y	Turn signal (right)	ON	Combina- tion switch	Turn right ON	 SKIA3009J
67	B	Ground	ON	—	0V	
70	W/B	Battery power supply	OFF	—	Battery voltage	

How to Proceed With Trouble Diagnosis

EKS00752

1. Confirm the symptom or customer complaint.
2. Understand operation description and function description. Refer to [LT-80, "System Description"](#) .
3. Perform preliminary check. Refer to [LT-86, "Preliminary Check"](#) .
4. Check symptom and repair or replace the cause of malfunction.
5. Do turn signal and hazard warning lamps operate normally? If YES: GO TO 6. If NO: GO TO 4.
6. INSPECTION END.

TURN SIGNAL AND HAZARD WARNING LAMPS

EKS00753

Preliminary Check CHECK POWER SUPPLY AND GROUND CIRCUIT

1. CHECK FUSES OR FUSIBLE LINK

Check for blown fuses or fusible link.

Unit	Power source	Fuse No.
BCM	Battery	f
	Ignition switch ON or START position	59

Refer to [LT-82, "Wiring Diagram — TURN —"](#) .

OK or NG

OK >> GO TO 2.

NG >> If fuse is blown, be sure to eliminate cause of malfunction before installing new fuse. Refer to [PG-4, "POWER SUPPLY ROUTING CIRCUIT"](#) .

2. CHECK POWER SUPPLY CIRCUIT

1. Disconnect BCM connector.
2. Check voltage between BCM harness connector and ground.

Terminals		(-)	Ignition switch position		
(+)			OFF	ACC	ON
Connector	Terminal (Wire color)	Ground	0V	0V	Battery voltage
M18	38 (W/L)		Battery voltage	Battery voltage	Battery voltage
M20	70 (W/B)				

OK or NG

OK >> GO TO 3.

NG >> Check harness for open between BCM and fuse.

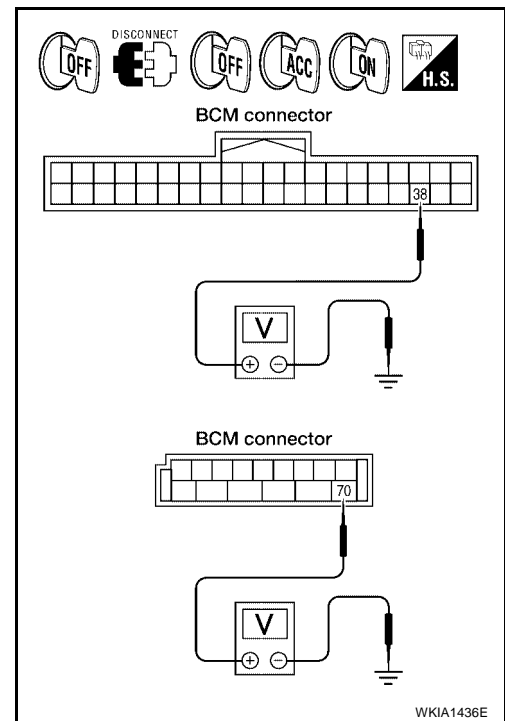

WKIA1436E

3. CHECK GROUND CIRCUIT

Check continuity between BCM harness connector and ground.

Terminals		(-)	Continuity
(+)			
Connector	Terminal (Wire color)	Ground	Yes
M20	67 (B)		

OK or NG

OK >> INSPECTION END.

NG >> Check ground circuit harness.

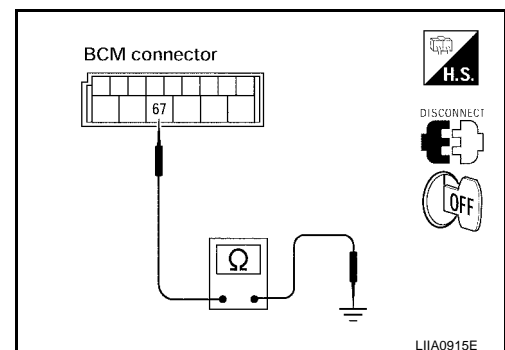

LIIA0915E

TURN SIGNAL AND HAZARD WARNING LAMPS

CONSULT-II Functions

EKS00754

CONSULT-II can display each diagnostic item using the diagnostic test modes shown following.

BCM diagnosis part	Check item, diagnosis mode	Description
FLASHER	Data monitor	Displays BCM input data in real time.
	CAN DIAG SUPPORT MNTR	The result of transmit/receive diagnosis of CAN communication can be read.
	Active test	Operation of electrical loads can be checked by sending driving signal to them.

CONSULT-II BASIC OPERATION

CAUTION:

If CONSULT-II is used with no connection of CONSULT-II CONVERTER, malfunctions might be detected in self-diagnosis depending on control unit which carries out CAN communication.

1. With the ignition switch OFF, connect CONSULT-II and CONSULT-II CONVERTER to the data link connector, then turn ignition switch ON.

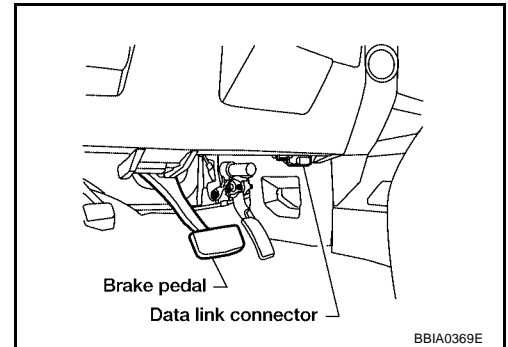

2. Touch "START (NISSAN BASED VHCL)".

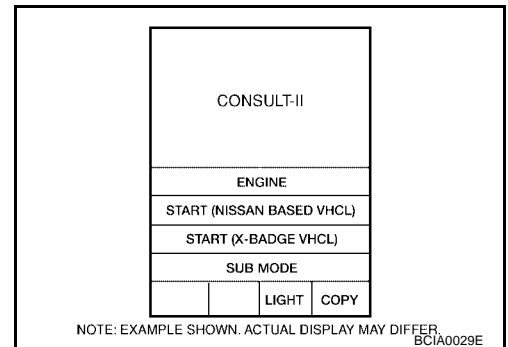

3. Touch "BCM" on "SELECT SYSTEM" screen. If "BCM" is not indicated, go to [GI-38, "CONSULT-II Data Link Connector \(DLC\) Circuit"](#).

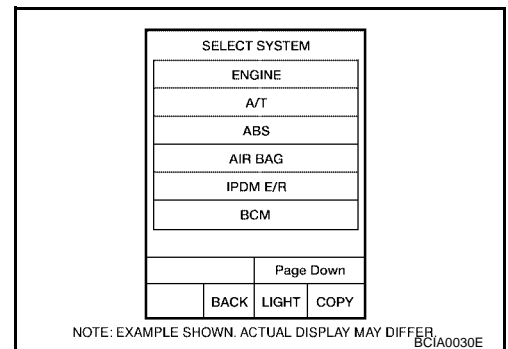

TURN SIGNAL AND HAZARD WARNING LAMPS

4. Touch "FLASHER" on "SELECT TEST ITEM" screen.

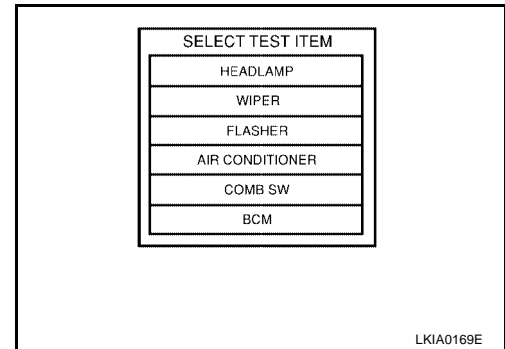

DATA MONITOR

Operation Procedure

1. Touch "FLASHER" on "SELECT TEST ITEM" screen.
2. Touch "DATA MONITOR" on "SELECT DIAG MODE" screen.
3. Touch either "ALL SIGNALS" or "SELECTION FROM MENU" on the "DATA MONITOR" screen.

All signals	Monitors all the signals.
Selection from menu	Selects and monitors the individual signal.

4. Touch "START".
5. When "SELECTION FROM MENU" is selected, touch items to be monitored. When "ALL SIGNALS" is selected, all the items will be monitored.
6. Touch "RECORD" while monitoring, then the status of the monitored item can be recorded. To stop recording, touch "STOP".

Display Item List

Monitor item	Contents
IGN ON SW "ON/OFF"	Displays "IGN position (ON)/OFF, ACC position (OFF)" judged from the ignition switch signal.
HAZARD SW "ON/OFF"	Displays "Hazard ON (ON)/Hazard OFF (OFF)" status, determined from hazard switch signal.
TURN SIGNAL R "ON/OFF"	Displays "Turn right (ON)/Other (OFF)" status, determined from lighting switch signal.
TURN SIGNAL L "ON/OFF"	Displays "Turn left (ON)/Other (OFF)" status, determined from lighting switch signal.
BRAKE SW "ON/OFF"	Displays status of stop lamp switch.

ACTIVE TEST

Operation Procedure

1. Touch "FLASHER" on "SELECT TEST ITEM" screen.
2. Touch "ACTIVE TEST" on "SELECT DIAG MODE" screen.
3. Touch item to be tested and check operation of the selected item.
4. During the operation check, touching "BACK" or "OFF" deactivates the operation.

Display Item List

Test item	Description
FLASHER (RH)	Turn signal lamp (right) can be operated by any ON-OFF operations.
FLASHER (LH)	Turn signal lamp (left) can be operated by any ON-OFF operations.

TURN SIGNAL AND HAZARD WARNING LAMPS

EKS00755

Turn Signal Lamp Does Not Operate

1. CHECK COMBINATION SWITCH INPUT SIGNAL

Ⓜ With CONSULT-II

Select "BCM" on CONSULT-II. With "FLASHER" data monitor, make sure "TURN SIGNAL R" and "TURN SIGNAL L" turns ON-OFF linked with operation of lighting switch.

**When lighting switch is : TURN SIGNAL R ON
TURN RH position**

**When lighting switch is : TURN SIGNAL L ON
TURN LH position**

DATA MONITOR	
MONITOR	
TURN SIGNAL R	ON
TURN SIGNAL L	ON

SKIA4499E

ⓧ Without CONSULT-II

Refer to [LT-99, "Combination Switch Inspection"](#).

OK or NG

OK >> GO TO 2.

NG >> Check lighting switch. Refer to [LT-99, "Combination Switch Inspection"](#).

2. ACTIVE TEST

Ⓜ With CONSULT-II

1. Select "FLASHER" during active test. Refer to [LT-88, "ACTIVE TEST"](#).

2. Make sure "FLASHER RIGHT" and "FLASHER LEFT" operate.

ⓧ Without CONSULT-II

GO TO 3.

OK or NG

OK >> Replace BCM. Refer to [BCS-25, "Removal and Installation of BCM"](#).

NG >> GO TO 3.

ACTIVE TEST	
FLASHER	OFF
RH	LH
MODE	BACK
LIGHT	COPY

SKIA6190E

3. CHECK TURN SIGNAL LAMPS CIRCUIT

1. Turn ignition switch OFF.

2. Disconnect BCM connector and front combination lamp LH and RH connectors.

3. Check continuity between BCM harness connector M20 terminal 60 (G/B) and front combination lamp LH harness connector E11 terminal 5 (G/B).

60 (G/B) – 5 (G/B) : Continuity should exist.

4. Check continuity between BCM harness connector M20 terminal 61 (G/Y) and front combination lamp RH harness connector E107 terminal 5 (G/Y).

61 (G/Y) – 5 (G/Y) : Continuity should exist.

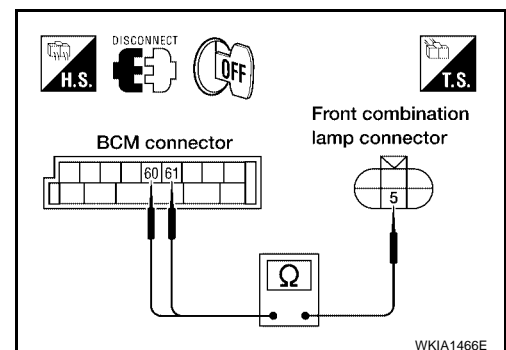

OK or NG

OK >> GO TO 4.

NG >> Repair harness or connector.

TURN SIGNAL AND HAZARD WARNING LAMPS

4. CHECK GROUND

1. Check continuity between front combination lamp LH harness connector E11 terminal 4 (B) and ground.

4 (B) – Ground : Continuity should exist.

2. Check continuity between front combination lamp RH harness connector E107 terminal 4 (B) and ground.

4 (B) – Ground : Continuity should exist.

OK or NG

- OK >> GO TO 5.
NG >> Repair harness or connector.

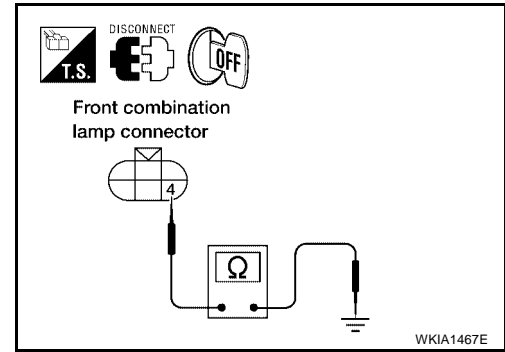

5. CHECK BULB

Check bulb standard of each turn signal lamp is correct.

OK or NG

- OK >> Replace BCM if turn signal lamps do not work after setting the connector again. Refer to [BCS-25. "Removal and Installation of BCM"](#).
NG >> Replace turn signal lamp bulb.

Rear Turn Signal Lamp Does Not Operate

EKS00756

1. CHECK TAIL LAMPS AND STOP LAMPS

Check bulb standard of each turn signal lamp is correct.

OK or NG

- OK >> GO TO 2.
NG >> Replace turn signal lamp bulb.

2. CHECK TURN SIGNAL LAMPS CIRCUIT

1. Disconnect BCM connector and rear combination lamp connector.

2. Check continuity between BCM harness connector M20 terminal 61 (G/Y) and rear combination lamp RH harness connector C14 terminal 8 (G/Y).

61 (G/Y) – 8 (G/Y) : Continuity should exist.

3. Check continuity between BCM harness connector M20 terminal 60 (G/B) and rear combination lamp LH harness connector C13 terminal 8 (G/B).

60 (G/B) – 8 (G/B) : Continuity should exist.

OK or NG

- OK >> GO TO 3.
NG >> Repair harness or connector.

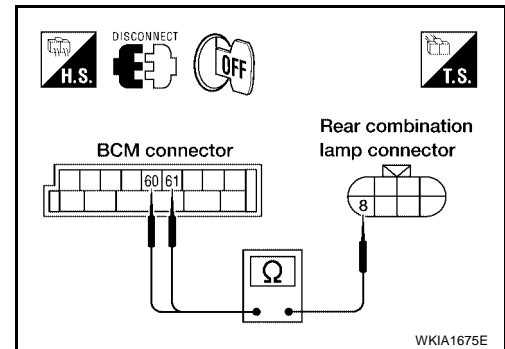

TURN SIGNAL AND HAZARD WARNING LAMPS

3. CHECK GROUND CIRCUIT

Check continuity between rear combination lamp harness connector C13 LH and C14 RH terminal 1 (B) and ground.

1 (B) – Ground : Continuity should exist.

OK or NG

- OK >> Check rear combination lamp connector for proper connection. Repair as necessary.
- NG >> Repair harness or connector.

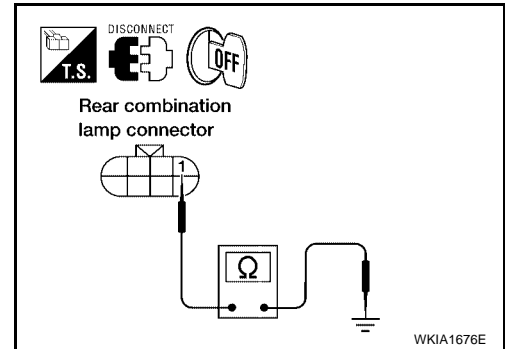

Hazard Warning Lamp Does Not Operate But Turn Signal Lamps Operate

EKS00757

1. CHECK BULB

Make sure bulb standard of each turn signal lamp is correct.

OK or NG

- OK >> GO TO 2.
- NG >> Replace turn signal lamp bulb.

2. CHECK HAZARD SWITCH INPUT SIGNAL

Ⓜ With CONSULT-II

Select "BCM" on CONSULT-II. With "FLASHER" data monitor, make sure "HAZARD SW" turns ON-OFF linked with operation of hazard switch.

When hazard switch is ON : HAZARD SW ON position

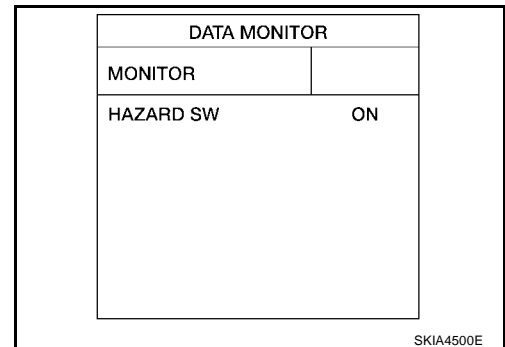

SKIA4500E

ⓧ Without CONSULT-II

Check voltage between BCM harness connector M18 terminal 29 (W/B) and ground.

Terminals		(-)	Condition	Voltage (Approx.)
(+)	Terminal (Wire color)			
Connector	Terminal (Wire color)			
M18	29 (W/B)	Ground	Hazard switch is ON	0V
			Hazard switch is OFF	5V

OK or NG

- OK >> Replace BCM. Refer to [BCS-25, "Removal and Installation of BCM"](#).
- NG >> GO TO 3.

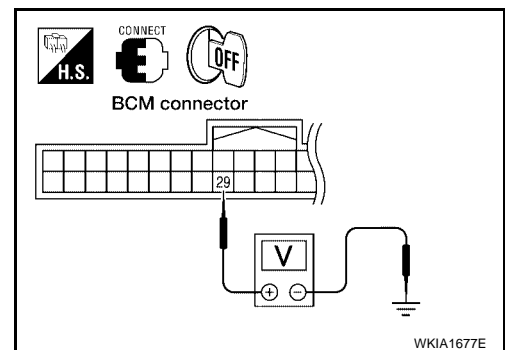

WKIA1677E

TURN SIGNAL AND HAZARD WARNING LAMPS

3. CHECK HAZARD SWITCH CIRCUIT

1. Turn ignition switch OFF.
2. Disconnect BCM connector and hazard switch connector.
3. Check continuity between BCM harness connector M18 terminal 29 (W/B) and hazard switch harness connector M55 terminal 4 (W/B).

29 (W/B) – 4 (W/B) : Continuity should exist.

OK or NG

- OK >> GO TO 4.
 NG >> Repair harness or connector.

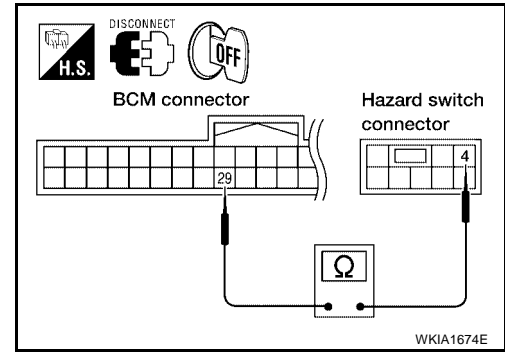

4. CHECK GROUND

Check continuity of hazard switch harness connector M55 terminal 6 (B) and ground.

6 (B) – Ground : Continuity should exist.

OK or NG

- OK >> GO TO 5.
 NG >> Repair harness or connector.

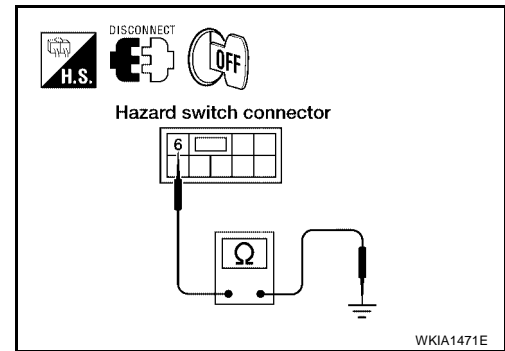

5. CHECK HAZARD SWITCH

1. Disconnect hazard switch connector.
2. Check continuity hazard switch.

Terminal		Condition	Continuity
Hazard switch			
4	6	Hazard switch is ON	Yes
		Hazard switch is OFF	No

OK or NG

- OK >> Replace BCM if turn signal lamps does not work after setting the connector again. Refer to [BCS-25, "Removal and Installation of BCM"](#) .
 NG >> Replace hazard switch.

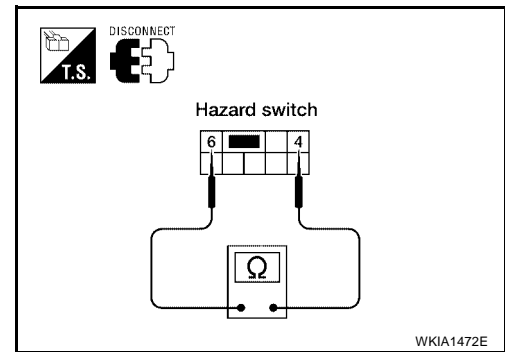

Turn Signal Indicator Lamp Does Not Operate

EKS00758

1. CHECK CAN COMMUNICATION SYSTEM

Check CAN communication. Refer to [LAN-8, "CAN COMMUNICATION"](#) .

OK or NG

- OK >> Replace combination meter. Refer to [DI-25, "Removal and Installation of Combination Meter"](#) .
 NG >> Repair as necessary.

TURN SIGNAL AND HAZARD WARNING LAMPS

Bulb Replacement (Front Turn Signal Lamp)

EKS00759

Refer to [LT-32, "FRONT TURN SIGNAL/PARKING LAMP"](#) .

A

Bulb Replacement (Rear Turn Signal Lamp)

EKS0075A

Refer to [LT-122, "Bulb Replacement"](#) in "REAR COMBINATION LAMP".

B

Removal and Installation of Front Turn Signal Lamp

EKS0075B

Refer to [LT-34, "Removal and Installation"](#) .

C

Removal and Installation of Rear Turn Signal Lamp

EKS0075C

Refer to [LT-122, "Removal and Installation"](#) in "REAR COMBINATION LAMP".

D

E

F

G

H

I

J

LT

L

M

LIGHTING AND TURN SIGNAL SWITCH

LIGHTING AND TURN SIGNAL SWITCH

PF2:25540

Removal and Installation

EKS0075D

REMOVAL

1. Remove steering column cover.
2. While pressing tabs, pull lighting and turn signal switch toward driver door and disconnect from the base.

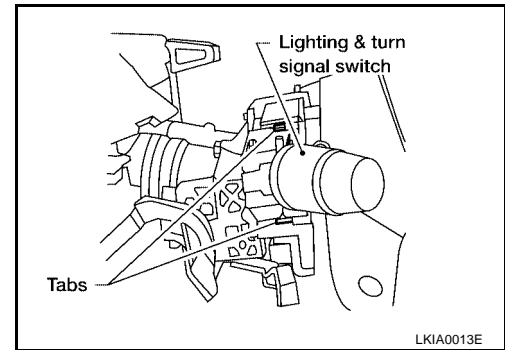

INSTALLATION

Installation is in the reverse order of removal.

HAZARD SWITCH

HAZARD SWITCH

PF2:25290

Removal and Installation

EKS0075E

REMOVAL

1. Remove cluster lid C. Refer to [IP-12, "CLUSTER LID C"](#).
2. While pressing the tab, push out the hazard switch.

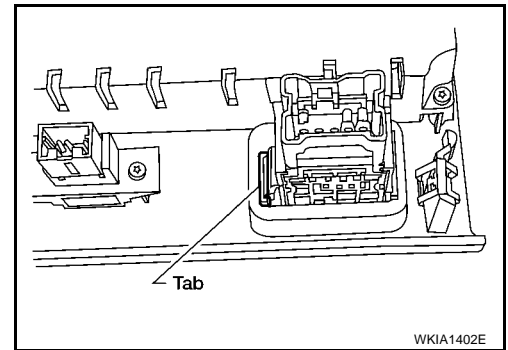

INSTALLATION

Installation is in the reverse order of removal.

A
B
C
D
E
F
G
H
I
J
LT
L
M

COMBINATION SWITCH

PFP:25567

EKS0075F

COMBINATION SWITCH

Wiring Diagram — COMBSW —

LT-COMBSW-01

— : DATA LINE

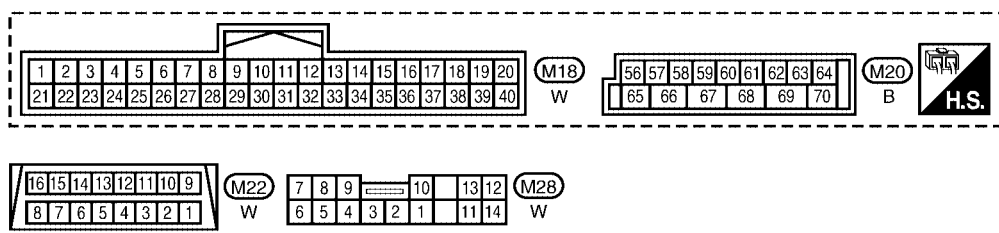
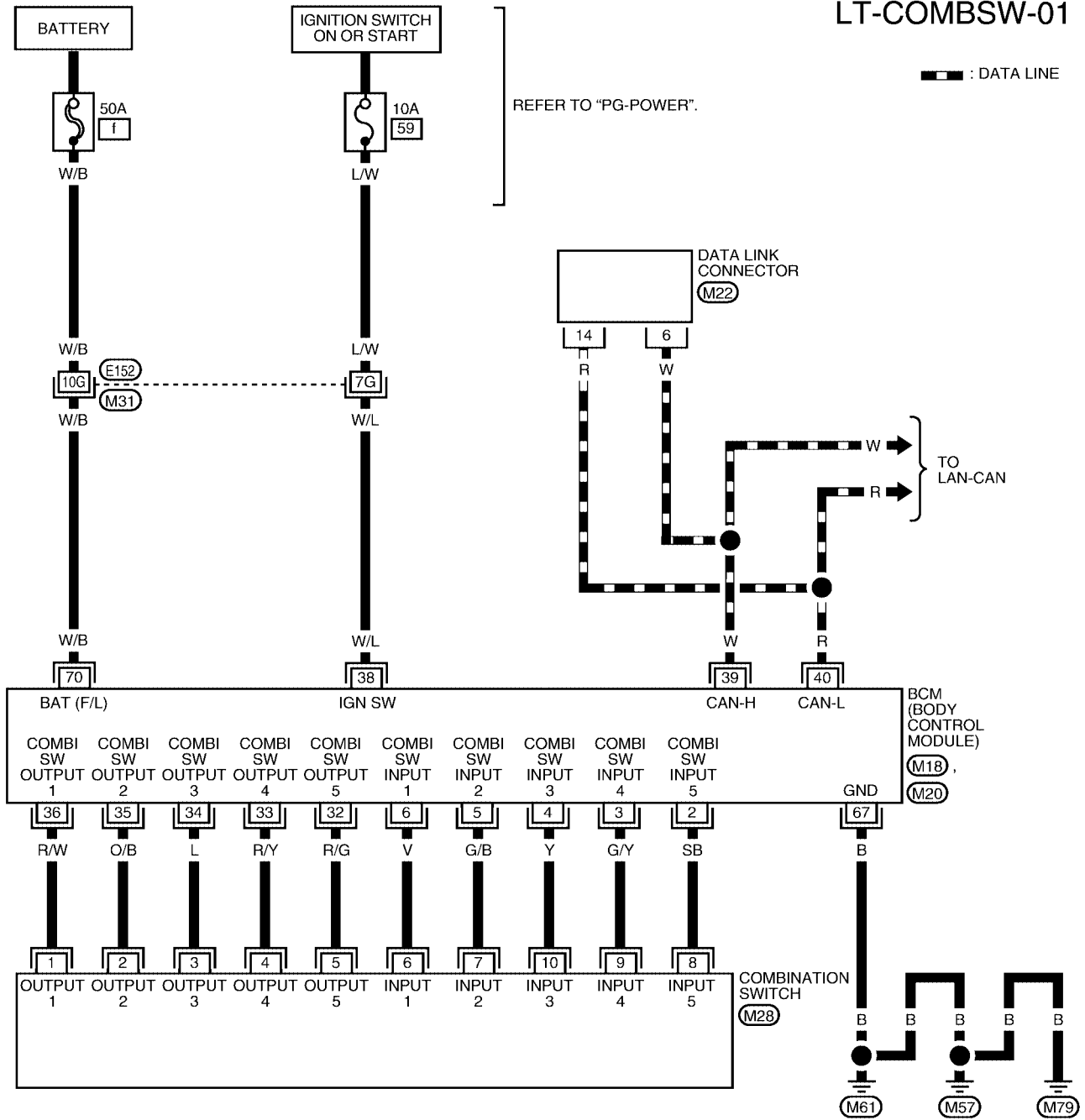

REFER TO THE FOLLOWING.

(M31) - SUPER MULTIPLE JUNCTION (SMJ)

WKWA1158E

COMBINATION SWITCH

Combination Switch Reading Function

EKS0075G

For details, refer to [BCS-3, "COMBINATION SWITCH READING FUNCTION"](#).

CONSULT-II Functions

EKS0075H

CONSULT-II can display each diagnostic item using the diagnostic test modes shown following.

BCM diagnosis part	Check item, diagnosis mode	Description
Combination switch	Data monitor	Displays BCM input data in real time.
	CAN DIAG SUPPORT MNTR	The result of transmit/receive diagnosis of CAN communication can be read.

CONSULT-II BASIC OPERATION

CAUTION:

If CONSULT-II is used with no connection of CONSULT-II CONVERTER, malfunctions might be detected in self-diagnosis depending on control unit which carries out CAN communication.

1. With the ignition switch OFF, connect CONSULT-II and CONSULT-II CONVERTER to the data link connector, then turn ignition switch ON.

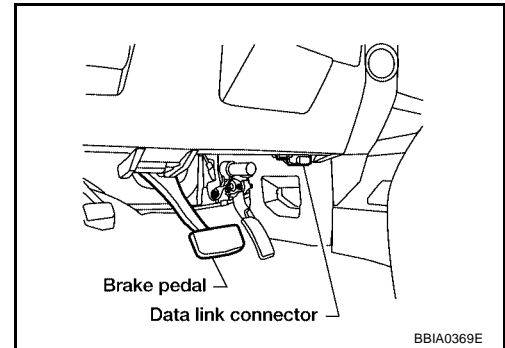

2. Touch "START (NISSAN BASED VHCL)".

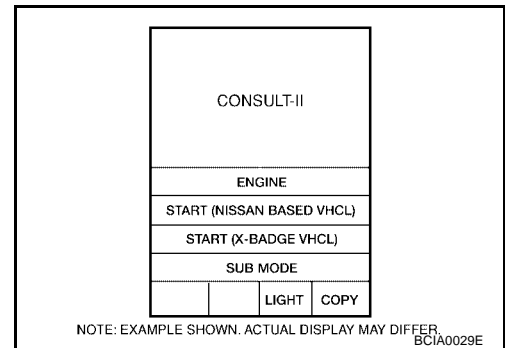

3. Touch "BCM" on "SELECT SYSTEM" screen. If "BCM" is not indicated, go to [GI-38, "CONSULT-II Data Link Connector \(DLC\) Circuit"](#).

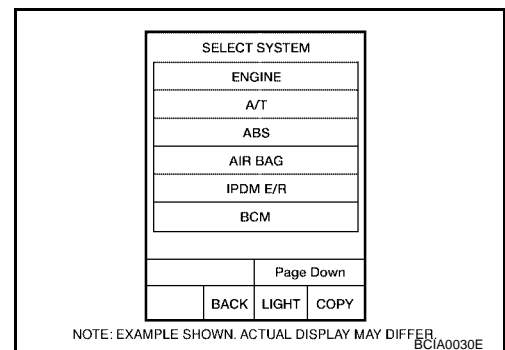

COMBINATION SWITCH

4. Touch "COMB SW".

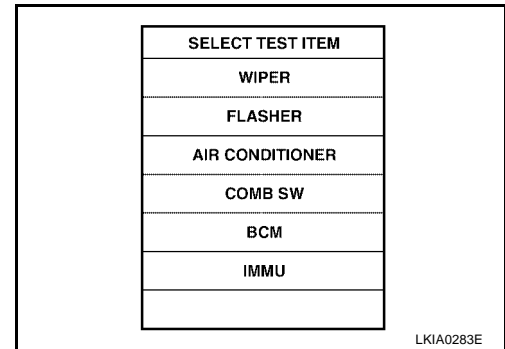

DATA MONITOR

Operation Procedure

1. Touch "COMB SW" on "SELECT TEST ITEM" screen.
2. Touch "DATA MONITOR" on "SELECT DIAG MODE" screen.
3. Touch either "ALL SIGNALS" or "SELECTION FROM MENU" on "DATA MONITOR" screen.

ALL SIGNALS	Monitors all the signals.
SELECTION FROM MENU	Selects and monitors individual signal.

4. Touch "START".
5. When "SELECTION FROM MENU" is selected, touch items to be monitored. When "ALL SIGNALS" is selected, all the signals will be monitored.
6. Touch "RECORD" while monitoring, then the status of the monitored item can be recorded. To stop recording, touch "STOP".

Display Item List

Monitor item name "OPERATION OR UNIT"	Contents
TURN SIGNAL R "ON/OFF"	Displays "Turn Right (ON)/Other (OFF)" status, determined from lighting switch signal.
TURN SIGNAL L "ON/OFF"	Displays "Turn Left (ON)/Other (OFF)" status, determined from lighting switch signal.
HI BEAM SW "ON/OFF"	Displays status (high beam switch: ON/Others: OFF) of high beam switch judged from lighting switch signal.
HEAD LAMP SW 1 "ON/OFF"	Displays "Headlamp switch 1 (ON)/Other (OFF)" status, determined from lighting switch signal.
HEAD LAMP SW 2 "ON/OFF"	Displays status (headlamp switch 2: ON/Others: OFF) of headlamp switch 2 judged from lighting switch signal.
TAIL LAMP SW "ON/OFF"	Displays status (lighting switch 1st position: ON/Others: OFF) of lighting switch judged from lighting switch signal.
PASSING SW "ON/OFF"	Displays status (flash-to-pass switch: ON/Others: OFF) of flash-to-pass switch judged from lighting switch signal.
AUTO LIGHT SW "ON/OFF"	Displays "Auto light switch (ON)/Other (OFF)" status, determined from lighting switch signal.
FR FOG SW "ON/OFF"	Displays "Front fog lamp switch (ON)/Other (OFF)" status, determined from lighting switch signal.
FR WIPER HI "ON/OFF"	Displays "Front Wiper HI (ON)/Other (OFF)" status, determined from wiper switch signal.
FR WIPER LOW "ON/OFF"	Displays "Front Wiper LOW (ON)/Other (OFF)" status, determined from wiper switch signal.
FR WIPER INT "ON/OFF"	Displays "Front Wiper INT (ON)/Other (OFF)" status, determined from wiper switch signal.
FR WASHER SW "ON/OFF"	Displays "Front Washer Switch (ON)/Other (OFF)" status, determined from wiper switch signal.
INT VOLUME [1 - 7]	Displays intermittent operation knob setting (1 - 7), determined from wiper switch signal.

COMBINATION SWITCH

EKS0075I

Combination Switch Inspection

1. SYSTEM CHECK

Referring to table below, check to which system the malfunctioning switch belongs.

System 1	System 2	System 3	System 4	System 5
—	FR WASHER	FR WIPER LO	TURN LH	TURN RH
FR WIPER HI	—	FR WIPER INT	PASSING	HEAD LAMP1
INT VOLUME 1	—	—	HEAD LAMP2	HI BEAM
—	INT VOLUME 3	AUTO LIGHT	—	TAIL LAMP
INT VOLUME 2	—	—	FR FOG	—

>> Check the system to which malfunctioning switch belongs, and GO TO 2.

2. SYSTEM CHECK

 With CONSULT-II

CAUTION:

If CONSULT-II is used with no connection of CONSULT-II CONVERTER, malfunctions might be detected in self-diagnosis depending on control unit which carries out CAN communication.

1. Connect CONSULT-II, and select "COMB SW" on "SELECT TEST ITEM" screen.
2. Select "DATA MONITOR".
3. Select "START", and confirm that other switches in malfunctioning system operate normally.

Example: When auto light switch is malfunctioning, confirm that "FRONT WIPER LOW" and "FRONT WIPER INT" in System 3, to which the auto light switch belongs, turn ON-OFF normally.

DATA MONITOR	
MONITOR	
TURN SIGNAL R	OFF
TURN SIGNAL L	OFF
HIBEAM SW	OFF
HEAD LAMP SW1	OFF
HEAD LAMP SW2	OFF
LIGHT SW 1ST	OFF
PASSING SW	OFF
AUTO LIGHT SW	OFF
FR FOG SW	OFF
	Page Down
	RECORD
MODE	BACK
LIGHT	COPY

SKIA7075E

 Without CONSULT-II

Operate combination switch, and confirm that other switches in malfunctioning system operate normally.

Example: When auto light switch is malfunctioning, confirm that FRONT WIPER LOW and FRONT WIPER INT in System 3, to which the auto light switch belongs, operate normally.

Check results

Other switches in malfunctioning system operate normally.>>Replace lighting switch or wiper switch.

Other switches in malfunctioning system do not operate normally.>>GO TO 3.

COMBINATION SWITCH

3. HARNESS INSPECTION

1. Disconnect BCM and combination switch connectors.
2. Check for continuity between BCM harness connector of the suspect system and the corresponding combination switch connector terminals.

Suspect system	Terminals				Continuity	
	BCM		Combination switch			
	Connector	Terminal (Wire color)	Connector	Terminal (Wire color)		
1	M18	Input 1	6 (V)	M28	6 (V)	Yes
		Output 1	36 (R/W)		1 (R/W)	
2		Input 2	5 (G/B)		7 (G/B)	
		Output 2	35 (O/B)		2 (O/B)	
3		Input 3	4 (Y)		10 (Y)	
		Output 3	34 (L)		3 (L)	
4		Input 4	3 (G/Y)		9 (G/Y)	
		Output 4	33 (R/Y)		4 (R/Y)	
5		Input 5	2 (SB)		8 (SB)	
		Output 5	32 (R/G)		5 (R/G)	

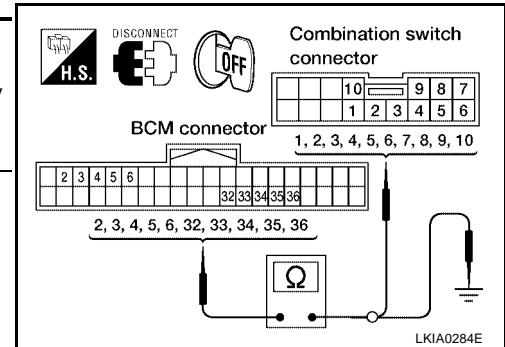

3. Check for continuity between each terminal of BCM harness connector in suspect malfunctioning system and ground.

Suspect system	Terminals				Continuity
	BCM(+)		-		
	Connector	Terminal (Wire color)			
1	M18	Input 1	6 (V)	Ground	No
		Output 1	36 (R/W)		
2		Input 2	5 (G/B)		
		Output 2	35 (O/B)		
3		Input 3	4 (Y)		
		Output 3	34 (L)		
4		Input 4	3 (G/Y)		
		Output 4	33 (R/Y)		
5		Input 5	2 (SB)		
		Output 5	32 (R/G)		

OK or NG

OK >> GO TO 4.

NG >> Check harness between BCM and combination switch for open or short circuit.

COMBINATION SWITCH

4. BCM OUTPUT TERMINAL INSPECTION

1. Turn lighting switch and wiper switch to OFF.
2. Set wiper dial to position 4.
3. Connect BCM and combination switch connectors, and check BCM output terminal voltage waveform of suspect malfunctioning system.

Suspect system	Terminals	
	Combination switch(+)	
	Connector	Terminal (Wire color)
1	M28	Output 1 1 (R/W)
2		Output 2 2 (O/B)
3		Output 3 3 (L)
4		Output 4 4 (R/Y)
5		Output 5 5 (R/G)

OK or NG

OK >> Open circuit in combination switch, GO TO 5.

NG >> Replace BCM.

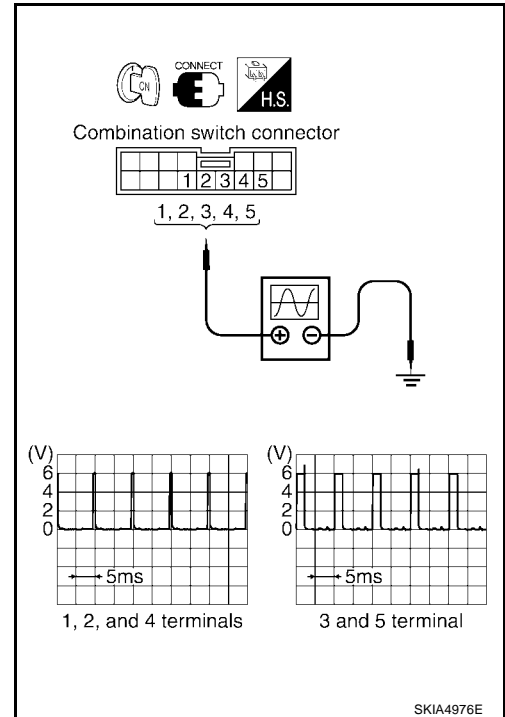

5. COMBINATION SWITCH INSPECTION

Referring to table below, perform combination switch inspection.

Procedure									
1	2		3	4		5	6		7
Replace lighting switch.	Confirm check results.	OK	INSPECTION END	Confirm check results.	OK	INSPECTION END	Confirm check results.	OK	INSPECTION END
		NG	Replace wiper switch.		NG	Replace switch base.		NG	Confirm symptom again.

>> INSPECTION END.

Removal and Installation

EKS0075J

For details, refer to [LT-94, "Removal and Installation"](#).

Switch Circuit Inspection

EKS0075K

For details, refer to [LT-99, "Combination Switch Inspection"](#).

STOP LAMP

STOP LAMP

PF2:26550

System Description

EKS0075L

Power is supplied at all times

- through 10A fuse [No. 20, located in fuse block (J/B)]
- to stop lamp switch terminal 1 and
- to stop lamp relay terminal 1 (with VDC).

When the brake pedal is pressed, the stop lamp switch is closed and power is supplied

- through stop lamp switch terminal 2
- to stop lamp relay terminal 3 (with VDC)
- through stop lamp relay terminal 4 (with VDC)
- to rear combination lamp LH and RH terminal 7 and
- to high-mounted stop lamp terminal 1.

Ground is supplied at all times

- to rear combination lamp LH and RH terminal 5
- through grounds E9, E15 and E24
- to high-mounted stop lamp terminal 2
- through grounds B117 and B132.

With power and ground supplied the stop lamps illuminate.

STOP LAMP

Wiring Diagram — STOP/L —

EKS0075M

LT-STOP/L-01

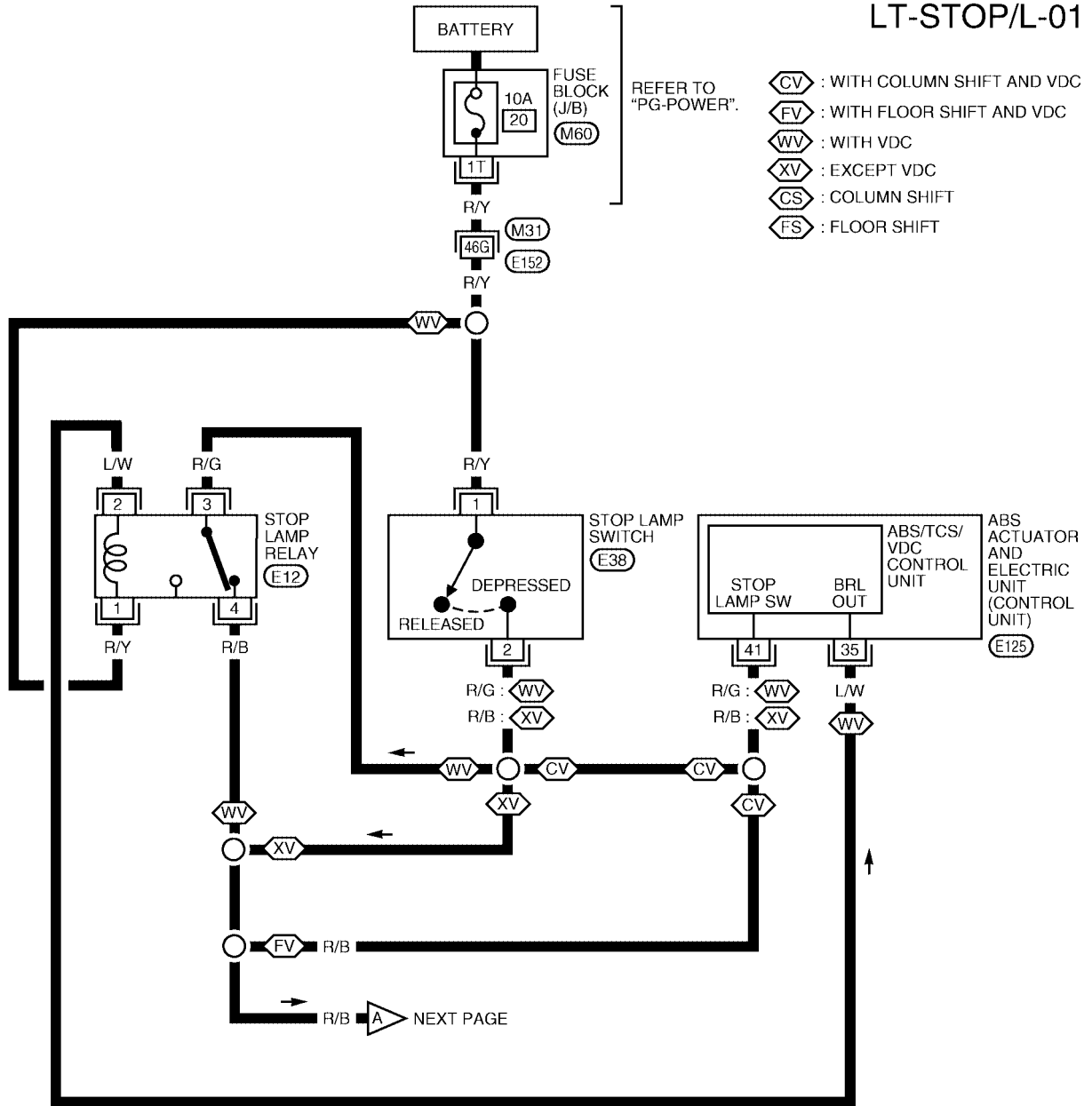

A
B
C
D
E
F
G
H
I
J
LT
L
M

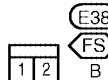
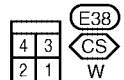
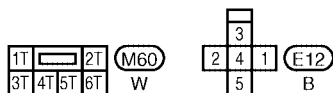

REFER TO THE FOLLOWING.

(M31) - SUPER MULTIPLE JUNCTION (SMJ)

(E125) - ELECTRICAL UNITS

WKWA1534E

STOP LAMP

LT-STOP/L-02

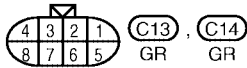
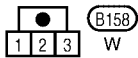
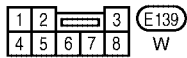
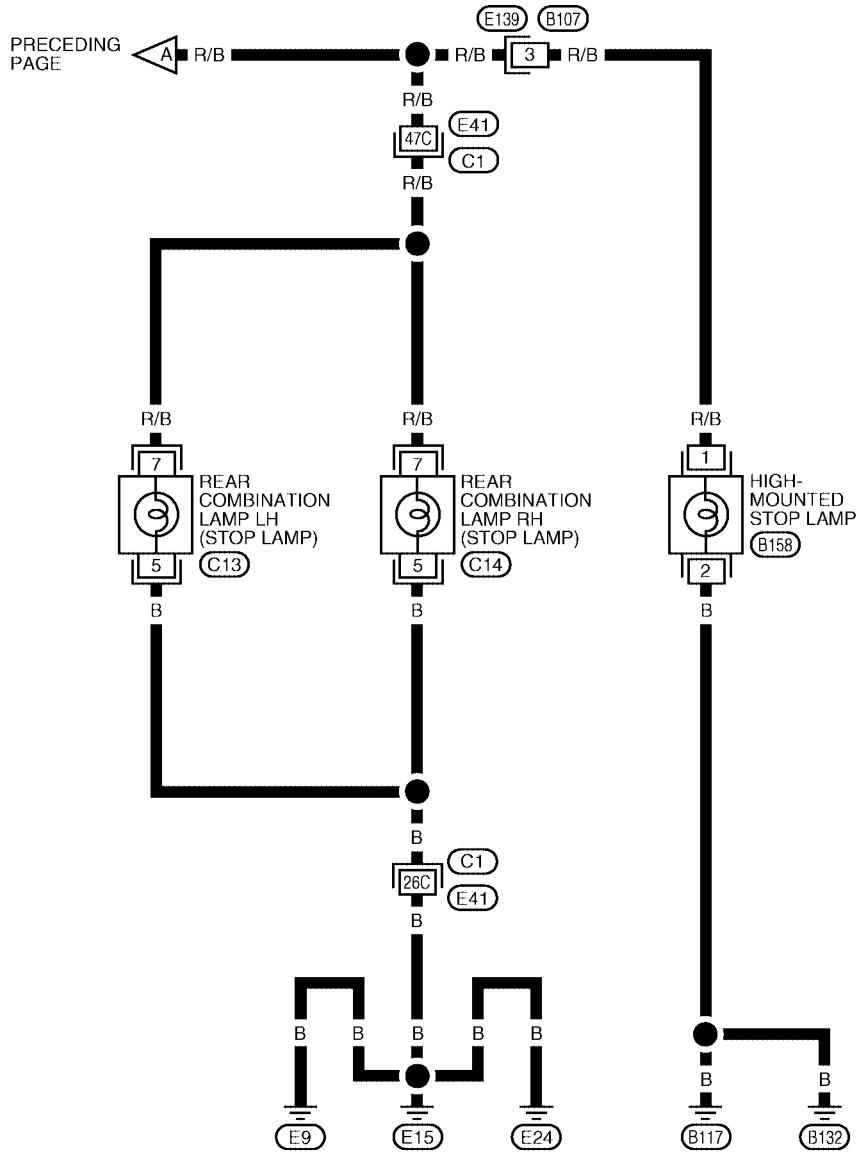

REFER TO THE FOLLOWING.
 (C1) - SUPER MULTIPLE JUNCTION (SMJ)

WKWA1510E

STOP LAMP

High-Mounted Stop Lamp BULB REPLACEMENT

EKS0075N

1. Remove the high-mounted stop lamp. Refer to [LT-105, "REMOVAL AND INSTALLATION"](#) .
2. Turn bulb socket counter clockwise to remove it from lamp housing.
3. Pull bulb from socket.

REMOVAL AND INSTALLATION

1. Remove access caps.
2. Disconnect the connector.
3. Remove 2 nuts and remove high-mounted stop lamp.
4. Installation is in the reverse order of removal.

High-mounted stop lamp nuts: 3.38 N·m (0.34 kg·m, 30 in·lb)

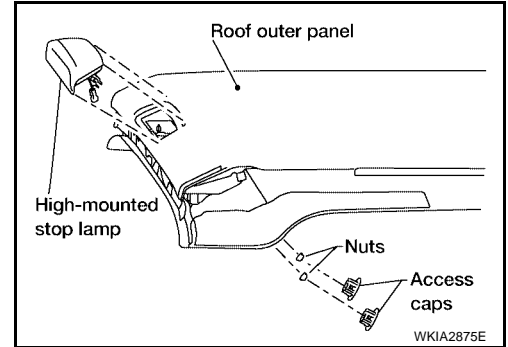

Stop Lamp BULB REPLACEMENT

EKS0075O

Refer to [LT-122, "Bulb Replacement"](#) in "REAR COMBINATION LAMP".

REMOVAL AND INSTALLATION

Refer to [LT-122, "Removal and Installation"](#) in "REAR COMBINATION LAMP".

A
B
C
D
E
F
G
H
I
J
L
M

LT

BACK-UP LAMP

PF#:26550

EKS0075P

BACK-UP LAMP

Wiring Diagram — BACK/L —

LT-BACK/L-01

: WITH NAVI

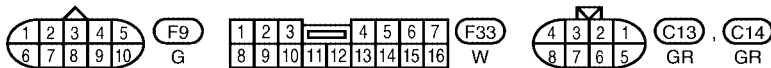
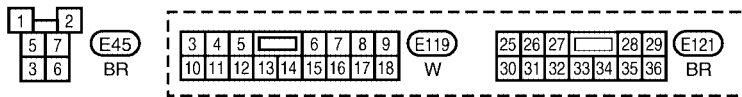
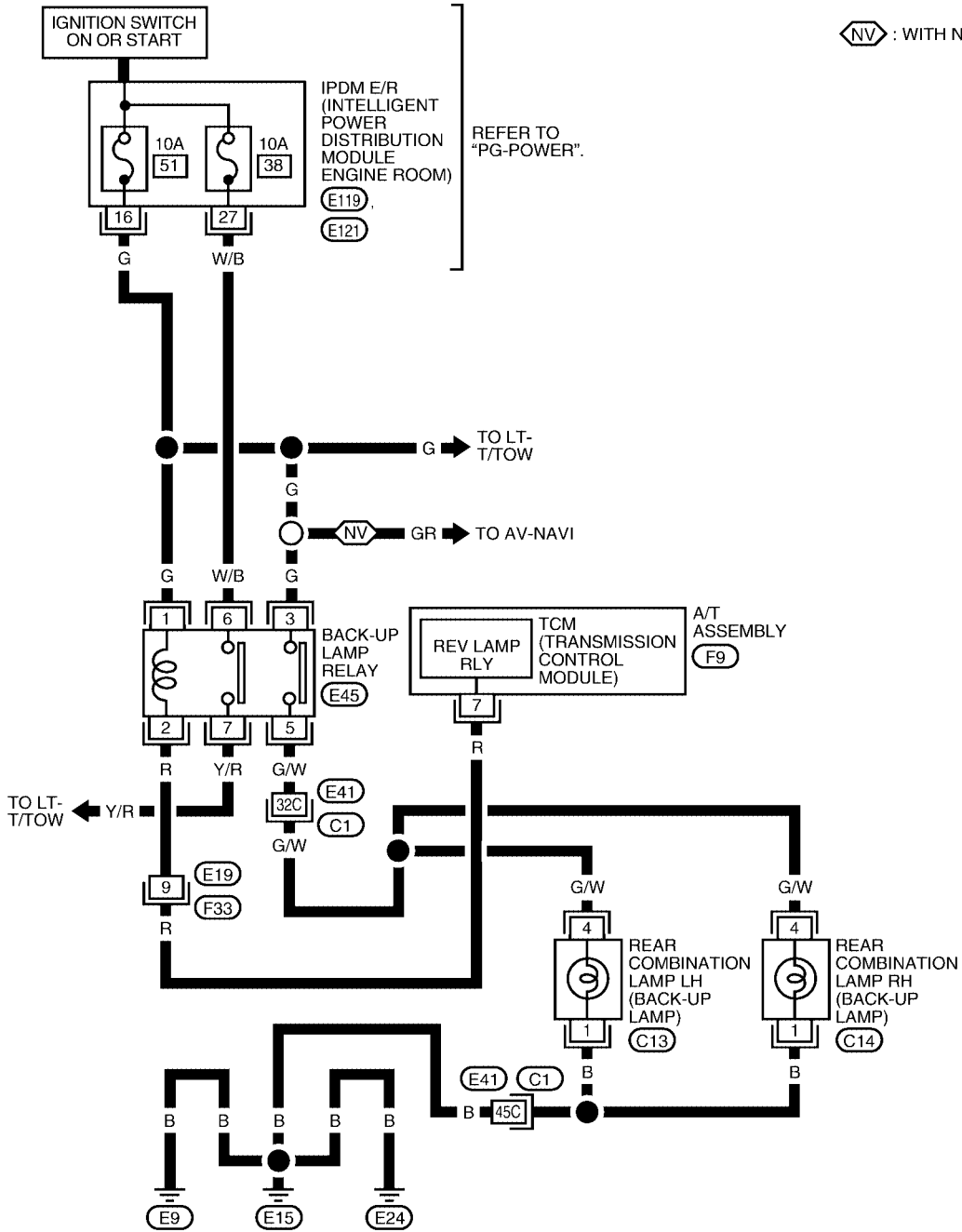

REFER TO THE FOLLOWING.

- SUPER MULTIPLE JUNCTION (SMJ)

WKWA1068E

BACK-UP LAMP

Bulb Replacement

EKS0075Q

Refer to [LT-122, "Bulb Replacement"](#) in "REAR COMBINATION LAMP".

A

Removal and Installation

EKS0075R

Refer to [LT-122, "Removal and Installation"](#) in "REAR COMBINATION LAMP".

B

C

D

E

F

G

H

I

J

LT

L

M

PARKING, LICENSE PLATE AND TAIL LAMPS

PARKING, LICENSE PLATE AND TAIL LAMPS

PFV:26550

Component Parts and Harness Connector Location

EKS0075S

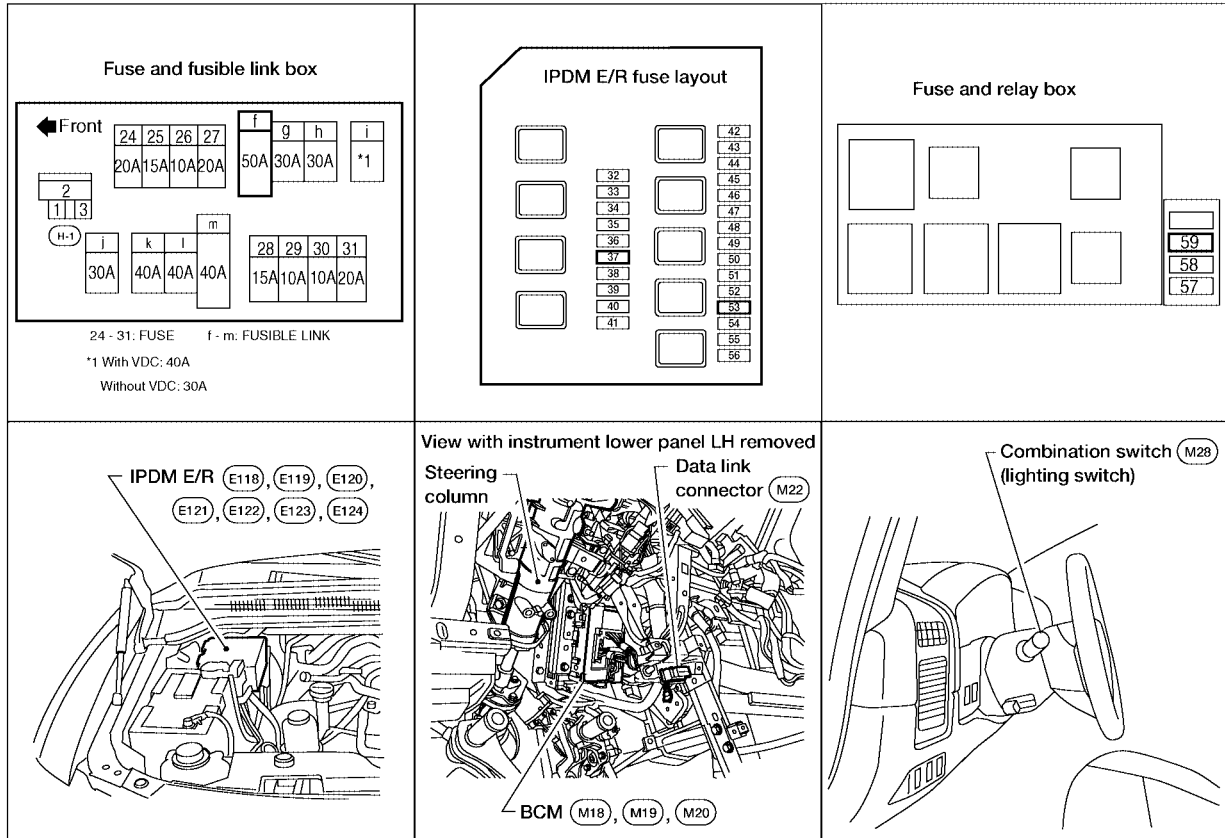

WKIA2833E

PARKING, LICENSE PLATE AND TAIL LAMPS

System Description

EKS0075T

Control of the parking, license plate, and tail lamp operation is dependent upon the position of the lighting switch (combination switch). When the lighting switch is placed in the 1ST position, the BCM (body control module) receives input signal requesting the parking, license plate, side marker and tail lamps to illuminate. This input signal is communicated to the IPDM E/R (intelligent power distribution module engine room) across the CAN communication lines. The central processing unit of the IPDM E/R controls the tail lamp relay coil. This relay, when energized, directs power to the parking, license plate and tail lamps, which then illuminate. Power is supplied at all times

- to tail lamp relay, located in the IPDM E/R
- through 20A fuse (No. 53, located in the IPDM E/R)
- to CPU (central processing unit) in the IPDM E/R
- to ignition relay, located in the IPDM E/R.

Power is also supplied at all times

- through 50A fusible link (letter f , located in the fuse and fusible link box)
- to BCM terminal 70.

With the ignition switch in the ON or START position, power is supplied

- through 10A fuse (No. 59, located in the fuse and relay box)
- to BCM terminal 38
- to ignition relay, located in the IPDM E/R.

Ground is supplied

- to BCM terminal 67
- through grounds M57, M61 and M79
- to IPDM E/R terminals 38 and 59
- through grounds E9, E15 and E24.

OPERATION BY LIGHTING SWITCH

With the lighting switch in the 1ST or 2ND position (or if the auto light system is activated), the BCM receives input signal requesting the parking, license plate, side marker and tail lamps to illuminate. This input signal is communicated to the IPDM E/R across the CAN communication lines. The CPU in the IPDM E/R controls the tail lamp relay coil, which when energized, directs power

- from the tail lamp relay through 10A fuse (No. 37, located in the IPDM E/R)
- to IPDM E/R terminal 57
- to front combination lamp LH and RH terminal 6
- to license plate lamps terminal +
- to rear combination lamp LH and RH terminal 6.

Ground is supplied

- to front combination lamp LH and RH terminal 4
- to rear combination lamp LH and RH terminal 1 and
- to license plate lamps terminal -
- through grounds E9, E15 and E24.

With power and ground supplied, the parking, license plate and tail lamps illuminate.

COMBINATION SWITCH READING FUNCTION

Refer to [LT-97, "Combination Switch Reading Function"](#) .

EXTERIOR LAMP BATTERY SAVER CONTROL

When the combination switch (lighting switch) is in the 1ST (or 2ND) position, and the ignition switch is turned from ON or ACC to OFF, the battery saver control feature is activated.

Under this condition, the parking, license and tail lamps remain illuminated for 5 minutes, then the parking, license plate and tail lamps are turned off.

Exterior lamp battery saver control mode can be changed by the function setting of CONSULT-II.

CAN Communication System Description

EKS0075U

Refer to [LAN-8, "CAN COMMUNICATION"](#) .

A
B
C
D
E
F
G
H
I
J

LT

L
M

PARKING, LICENSE PLATE AND TAIL LAMPS

Schematic

EKS0075V

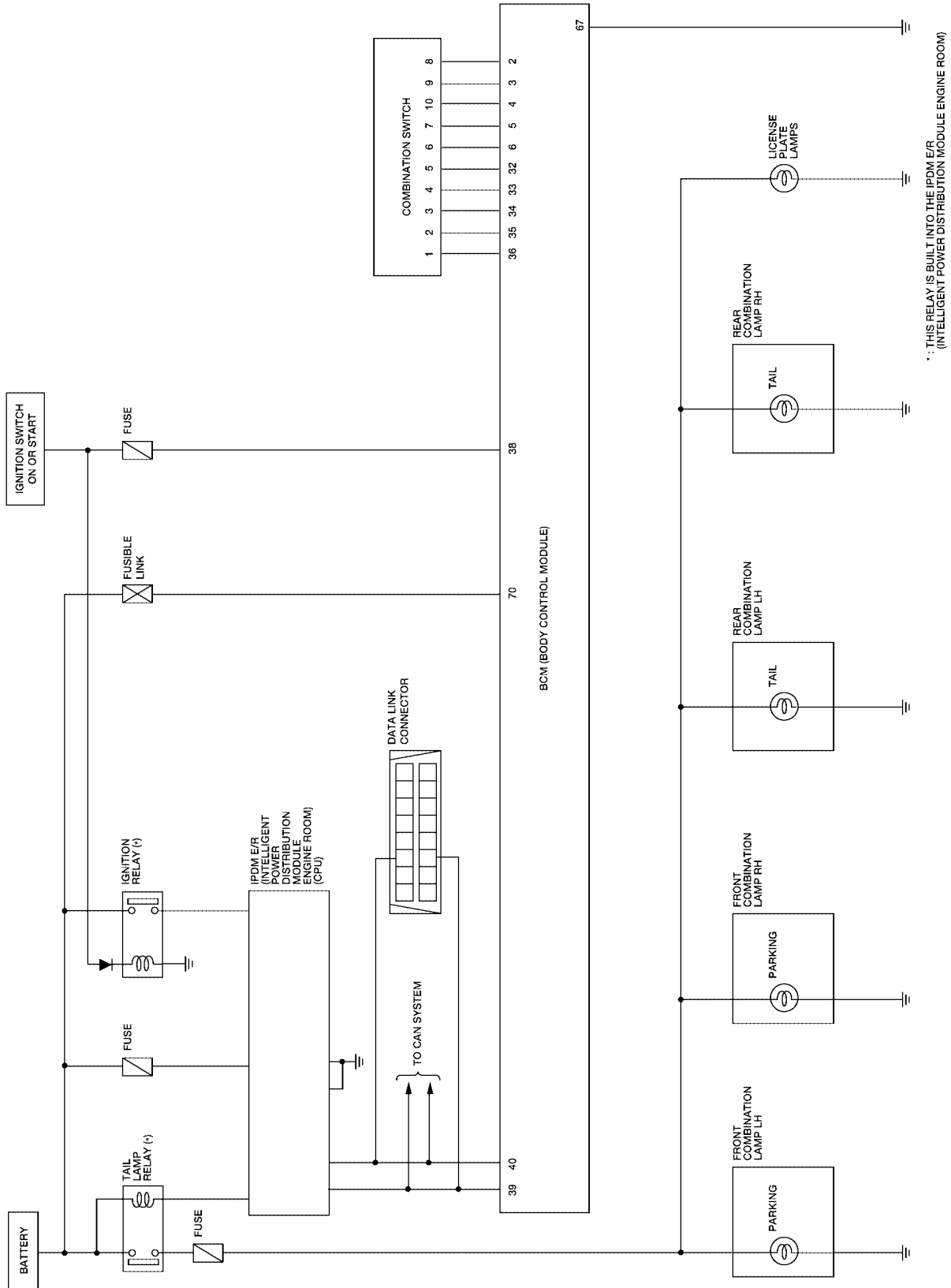

WKWA1069E

PARKING, LICENSE PLATE AND TAIL LAMPS

Wiring Diagram — TAIL/L —

EKS0075W

LT-TAIL/L-01

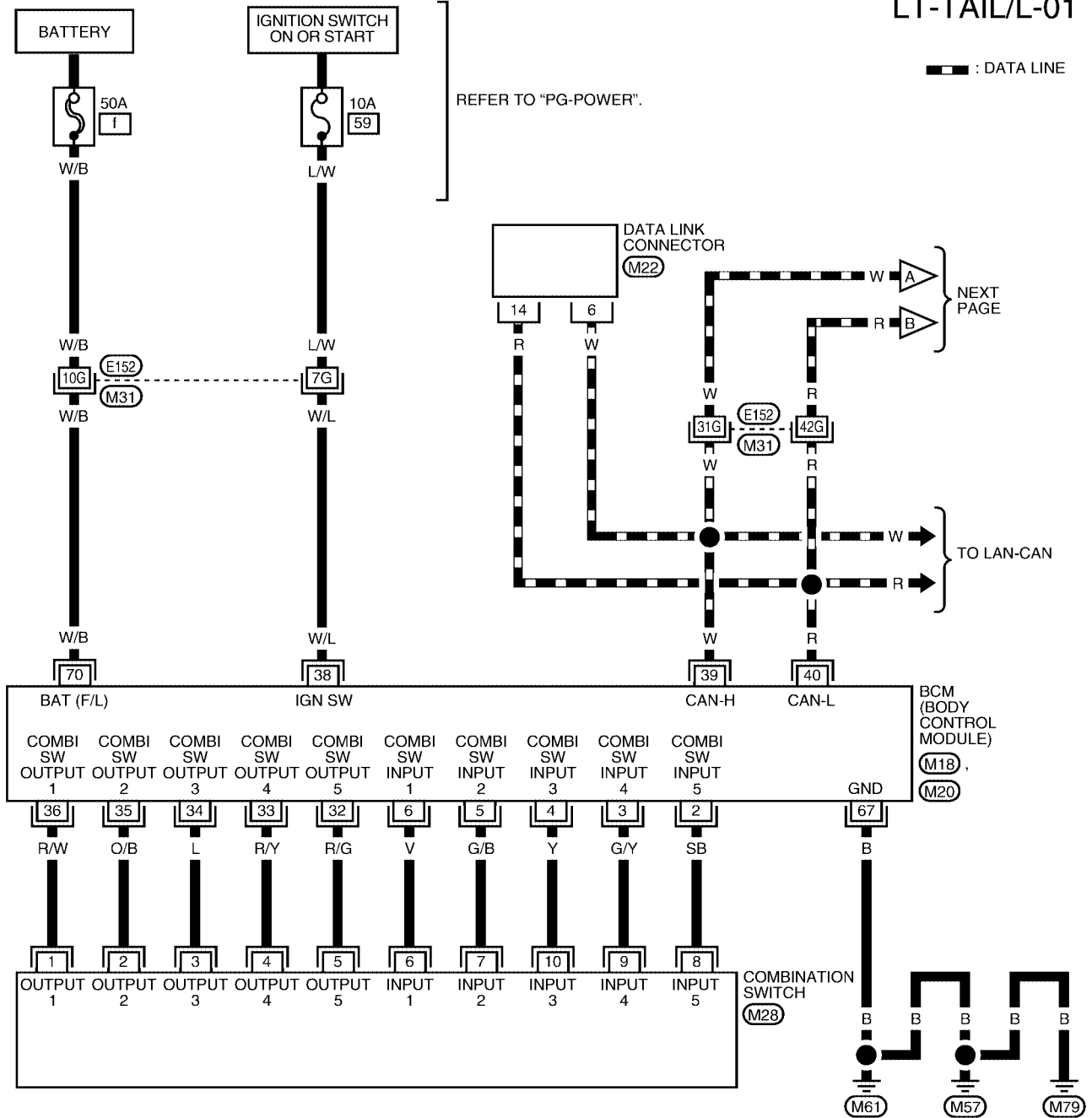

A
B
C
D
E
F
G
H
I
J
LT
L
M

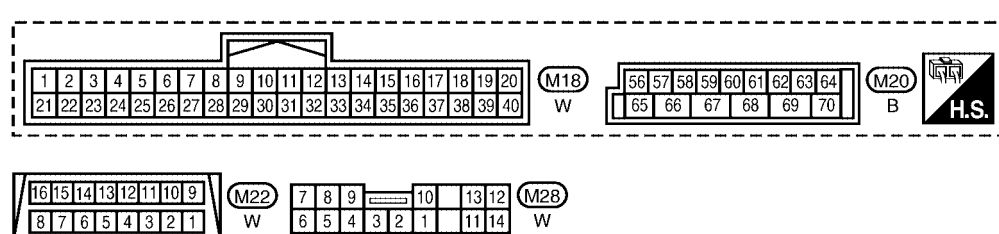

WKWA1159E

PARKING, LICENSE PLATE AND TAIL LAMPS

LT-TAIL/L-02

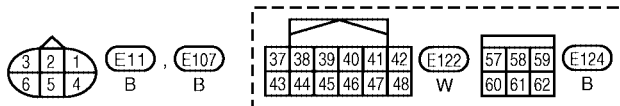
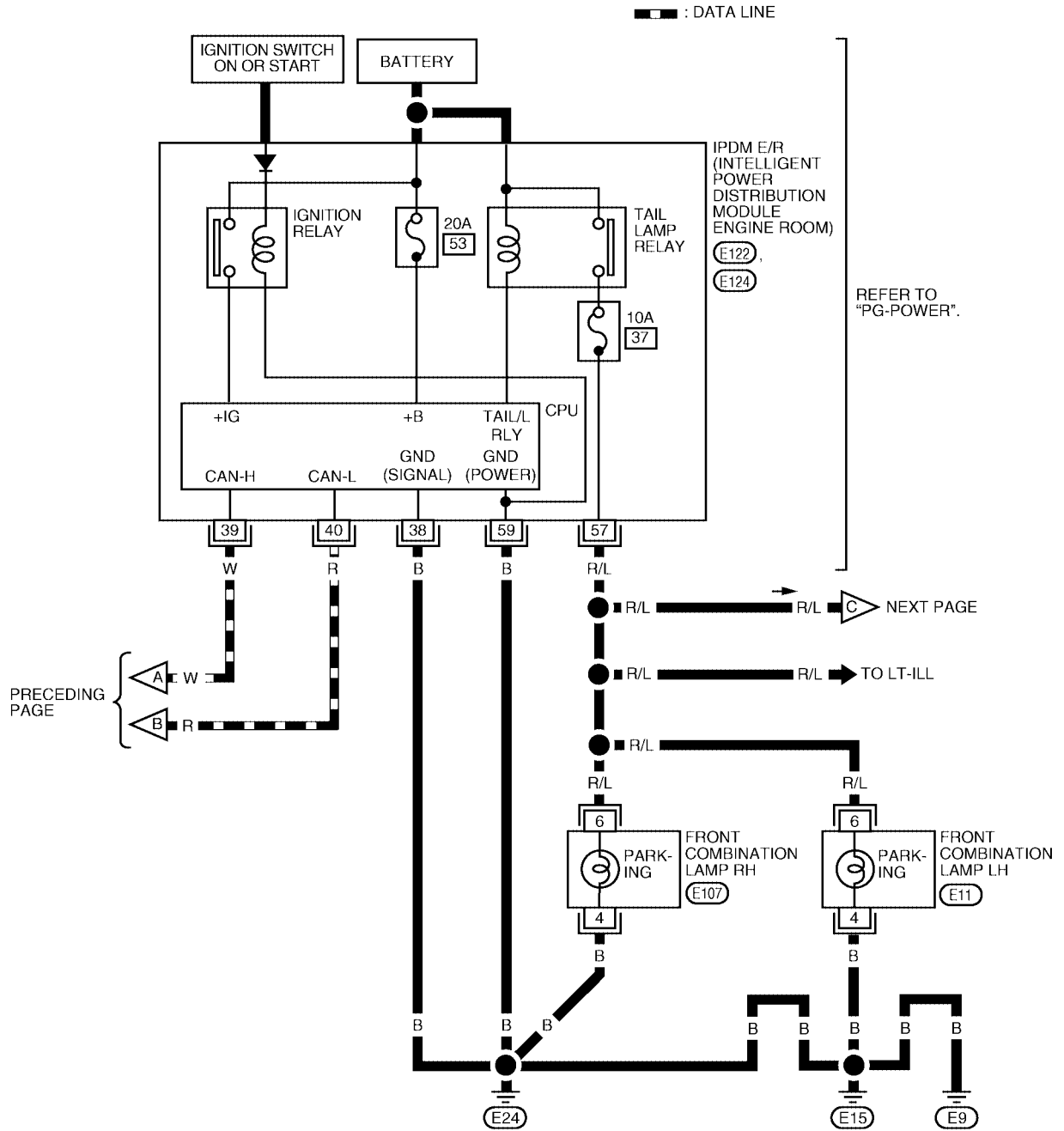

WKWA1480E

PARKING, LICENSE PLATE AND TAIL LAMPS

LT-TAIL/L-03

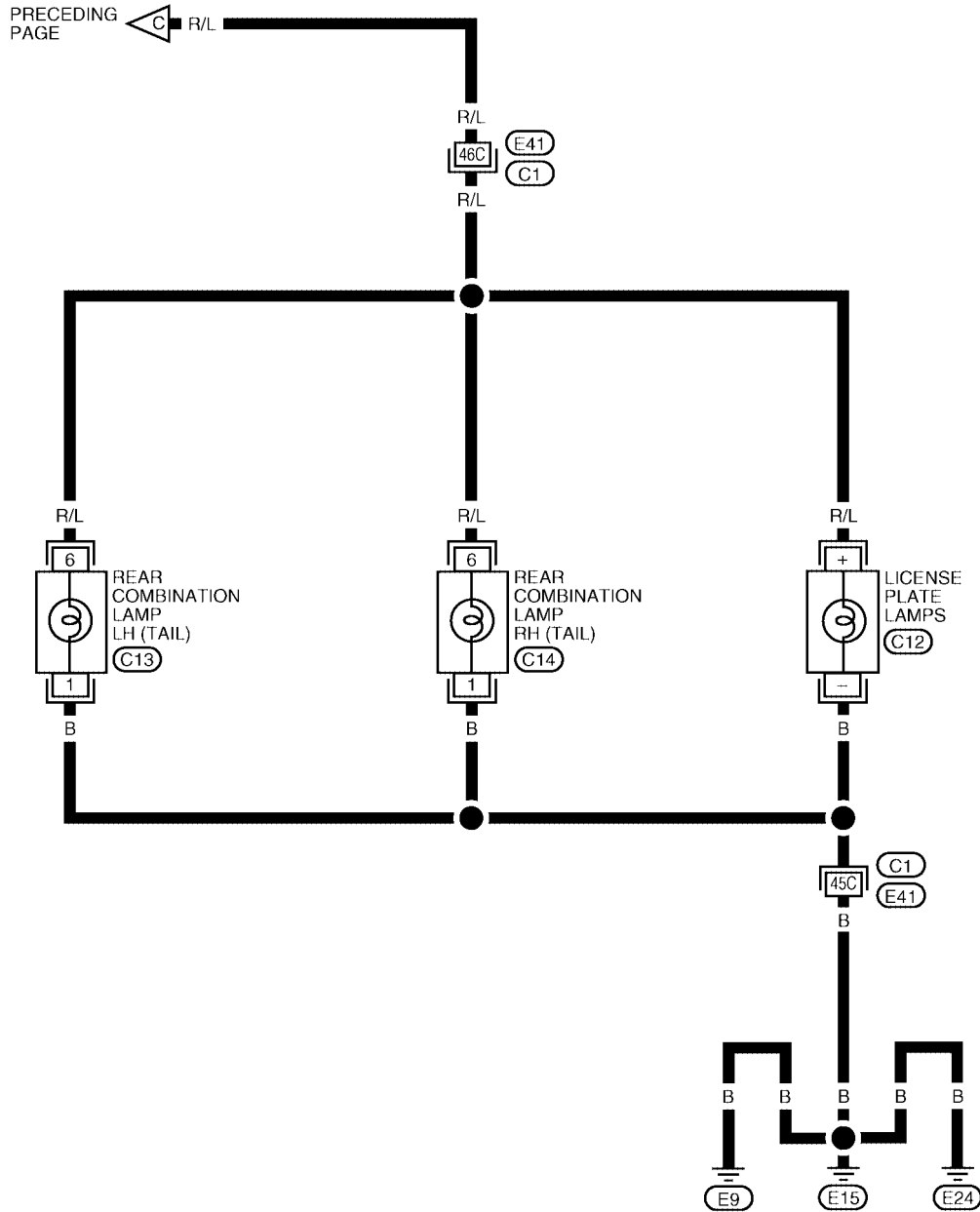

A
B
C
D
E
F
G
H
I
J
LT
L
M

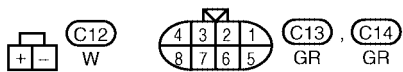

REFER TO THE FOLLOWING.
 (C1) - SUPER MULTIPLE JUNCTION (SMJ)

WKWA1562E

PARKING, LICENSE PLATE AND TAIL LAMPS

Terminals and Reference Value for BCM

EKS0075X

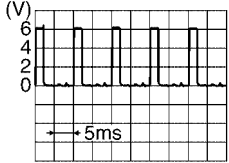
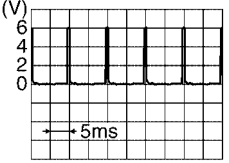
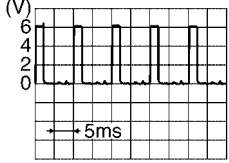
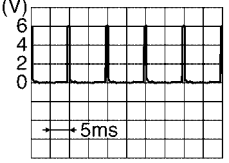
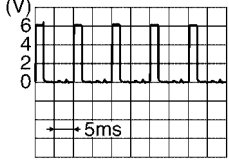
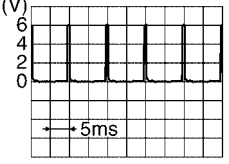
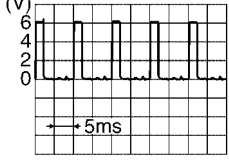
Terminal No.	Wire color	Signal name	Measuring condition		Reference value (Approx.)
			Ignition switch	Operation or condition	
2	SB	Combination switch input 5	ON	Lighting, turn, wiper OFF Wiper dial position 4	 <p style="text-align: right;">SKIA5291E</p>
3	G/Y	Combination switch input 4	ON	Lighting, turn, wiper OFF Wiper dial position 4	 <p style="text-align: right;">SKIA5292E</p>
4	Y	Combination switch input 3	ON	Lighting, turn, wiper OFF Wiper dial position 4	 <p style="text-align: right;">SKIA5291E</p>
5	G/B	Combination switch input 2	ON	Lighting, turn, wiper OFF Wiper dial position 4	 <p style="text-align: right;">SKIA5292E</p>
6	V	Combination switch input 1			
32	R/G	Combination switch output 5	ON	Lighting, turn, wiper OFF Wiper dial position 4	 <p style="text-align: right;">SKIA5291E</p>
33	R/Y	Combination switch output 4	ON	Lighting, turn, wiper OFF Wiper dial position 4	 <p style="text-align: right;">SKIA5292E</p>
34	L	Combination switch output 3	ON	Lighting, turn, wiper OFF Wiper dial position 4	 <p style="text-align: right;">SKIA5291E</p>

PARKING, LICENSE PLATE AND TAIL LAMPS

Terminal No.	Wire color	Signal name	Measuring condition		Reference value (Approx.)
			Ignition switch	Operation or condition	
35	O/B	Combination switch output 2	ON	Lighting, turn, wiper OFF Wiper dial position 4	
36	R/W	Combination switch output 1			
38	W/L	Ignition switch (ON)	ON	—	Battery voltage
39	W	CAN- H	—	—	—
40	R	CAN- L	—	—	—
67	B	Ground	ON	—	0V
70	W/B	Battery power supply (fusible link)	OFF	—	Battery voltage

Terminals and Reference Values for IPDM E/R

EKS0075Y

Terminal No.	Wire color	Signal name	Measuring condition		Reference value (Approx.)	
			Ignition switch	Operation or condition		
38	B	Ground	ON	—	0V	
39	W	CAN- H	—	—	—	
40	R	CAN- L	—	—	—	
57	R/L	Parking, license, and tail lamp	ON	Lighting switch 1ST position	OFF	0V
					ON	Battery voltage
59	B	Ground	ON	—	0V	

How to Proceed With Trouble Diagnosis

EKS0075Z

1. Confirm the symptom or customer complaint.
2. Understand operation description and function description. Refer to [LT-109, "System Description"](#) .
3. Carry out the Preliminary Check. Refer to [LT-116, "Preliminary Check"](#) .
4. Check symptom and repair or replace the cause of malfunction.
5. Do the parking, license and tail lamps operate normally? If YES: GO TO 6. If NO: GO TO 4.
6. INSPECTION END.

PARKING, LICENSE PLATE AND TAIL LAMPS

EKS00760

Preliminary Check CHECK POWER SUPPLY AND GROUND CIRCUIT

1. CHECK FUSES OR FUSIBLE LINK

Check for blown fuses or fusible link.

Unit	Power source	Fuse No.
BCM	Battery	f
	Ignition switch ON or START position	59
IPDM E/R	Battery	53
	Battery (Tail lamps ON)	37

Refer to [LT-111, "Wiring Diagram — TAIL/L —"](#) .

OK or NG

OK >> GO TO 2.

NG >> If fuse is blown, be sure to eliminate cause of malfunction before installing new fuse. Refer to [PG-4, "POWER SUPPLY ROUTING CIRCUIT"](#) .

2. CHECK POWER SUPPLY CIRCUIT

1. Disconnect BCM connector.
2. Check voltage between BCM harness connector and ground.

Terminals (+)		(-)	Ignition switch position		
Connector	Terminal (Wire color)		OFF	ACC	ON
M18	38 (W/L)	Ground	0V	0V	Battery voltage
M20	70 (W/B)		Battery voltage	Battery voltage	Battery voltage

OK or NG

OK >> GO TO 3.

NG >> Check harness for open between BCM and fuse.

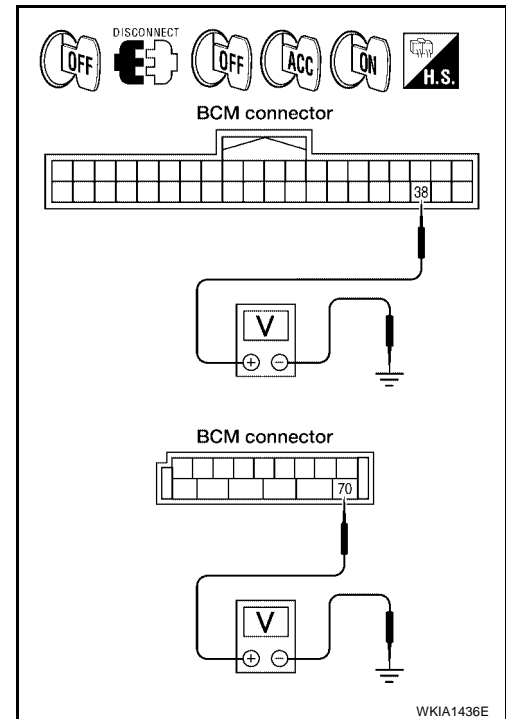

3. CHECK GROUND CIRCUIT

Check continuity between BCM harness connector and ground.

Terminals (+)		(-)	Continuity
Connector	Terminal (Wire color)		
M20	67 (B)	Ground	Yes

OK or NG

OK >> INSPECTION END.

NG >> Check ground circuit harness.

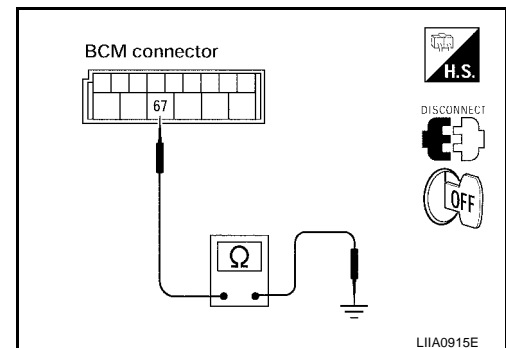

PARKING, LICENSE PLATE AND TAIL LAMPS

CONSULT-II Functions

EKS00761

Refer to [LT-18, "CONSULT-II Functions \(BCM\)"](#) and [LT-21, "CONSULT-II Functions \(IPDM E/R\)"](#) in HEAD-LAMP (FOR USA).

Parking, License Plate and/or Tail Lamps Do Not Illuminate

EKS00762

1. CHECK COMBINATION SWITCH INPUT SIGNAL

☐ With CONSULT-II
Select "BCM" on CONSULT-II. With "HEAD LAMP" data monitor, make sure "TAIL LAMP SW" turns ON-OFF linked with operation of lighting switch.

When lighting switch is in 1ST position : TAIL LAMP SW ON

☒ Without CONSULT-II
Refer to [LT-99, "Combination Switch Inspection"](#).

OK or NG

OK >> GO TO 2.

NG >> Check lighting switch. Refer to [LT-99, "Combination Switch Inspection"](#).

DATA MONITOR	
MONITOR	
TAIL LAMP SW	ON

WKIA1160E

2. ACTIVE TEST

- ☐ With CONSULT-II
1. Select "IPDM E/R" on CONSULT-II. and select "ACTIVE TEST" on "SELECT DIAG MODE" screen.
 2. Select "EXTERNAL LAMPS" on "SELECT TEST ITEM" screen.
 3. Touch "TAIL".
 4. Make sure parking, license plate and tail lamps operate.

Parking, license plate and tail lamps should operate

- ☒ Without CONSULT-II
1. Start auto active test. Refer to [PG-22, "Auto Active Test"](#).
 2. Make sure parking, license plate and tail lamps operate.

Parking, license plate and tail lamps should operate

OK or NG

OK >> GO TO 3.

NG >> GO TO 4.

ACTIVE TEST			
EXTERNAL LAMPS		OFF	
		TAIL	
LO		HI	
FOG			
MODE	BACK	LIGHT	COPY

WKIA1438E

3. CHECK IPDM E/R

1. Select "IPDM E/R" on CONSULT-II. and select "DATA MONITOR" on "SELECT DIAG MODE" screen.
2. Make sure "TAIL & CLR REQ" turns ON when lighting switch is in 1ST position.

When lighting switch is in 1ST position : TAIL & CLR REQ ON

OK or NG

OK >> Replace IPDM E/R.

NG >> Replace BCM. Refer to [BCS-25, "Removal and Installation of BCM"](#).

DATA MONITOR			
MONITOR			
TAIL&CLR REQ		ON	
		RECORD	
MODE	BACK	LIGHT	COPY

SKIA5958E

PARKING, LICENSE PLATE AND TAIL LAMPS

4. CHECK INPUT SIGNAL

Ⓟ With CONSULT-II

1. Turn ignition switch OFF.
2. Disconnect front combination lamp, license plate lamp and rear combination lamp connectors.
3. Select "IPDM E/R" on CONSULT-II. and select "ACTIVE TEST" on "SELECT DIAG MODE" screen.
4. Select "TAIL LAMP" on "SELECT TEST ITEM" screen.
5. Touch "ON" screen.
6. When tail lamp is operating, check voltage between front combination lamp, license plate lamp, rear combination lamp harness connector and ground.

ⓧ Without CONSULT-II

1. Turn ignition switch OFF.
2. Start auto active test. Refer to [PG-22, "Auto Active Test"](#) .
3. When tail lamp is operating, check voltage between front combination lamp, license plate lamp, rear combination lamp harness connector and ground.

Terminals			(-)	Voltage
Front combination lamp (+)				
Connector		Terminal (Wire color)	Ground	Battery voltage
RH	E107	6 (R/L)		
LH	E11			

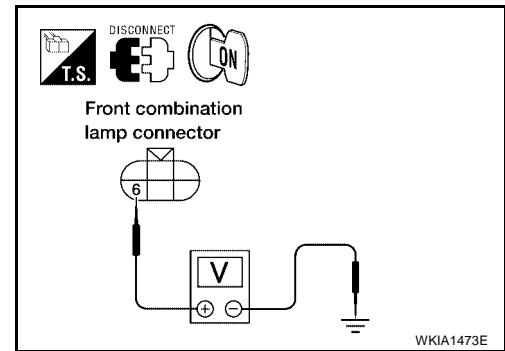

Terminals			(-)	Voltage
License plate lamps (+)				
Connector		Terminal (Wire color)	Ground	Battery voltage
C12		+ (R/L)		

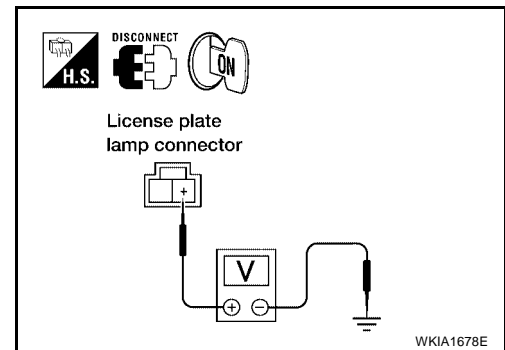

Terminals			(-)	Voltage
Rear combination lamp (+)				
Connector		Terminal (Wire color)	Ground	Battery voltage
RH	C14	6 (R/L)		
LH	C13			

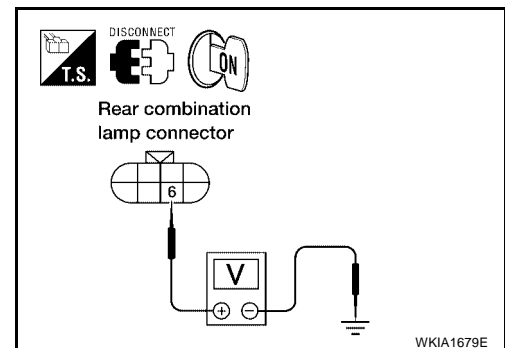

OK or NG

- OK >> GO TO 6.
 NG >> GO TO 5.

PARKING, LICENSE PLATE AND TAIL LAMPS

5. CHECK PARKING, LICENSE PLATE AND TAIL LAMP CIRCUIT

1. Turn ignition switch OFF.
2. Disconnect IPDM E/R connector.
3. Check continuity between IPDM E/R harness connector and front side marker lamp harness connector.

Terminals					Continuity
IPDM E/R		Front combination lamp			
Connector	Terminal (Wire color)	Connector	Terminal (Wire color)		
E124	57 (R/L)	RH	E107	6 (R/L)	Yes
		LH	E11		

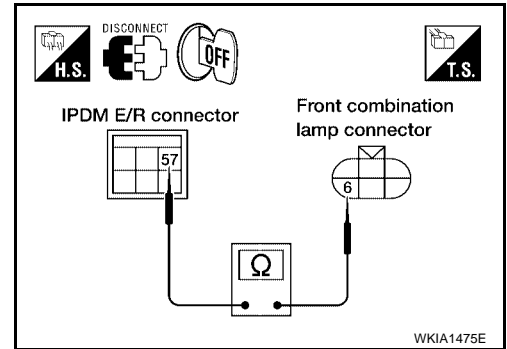

4. Check continuity between IPDM E/R harness connector and license plate lamps harness connector.

Terminals					Continuity
IPDM E/R		License plate lamps			
Connector	Terminal (Wire color)	Connector	Terminal (Wire color)		
E124	57 (R/L)	C12	+ (R/L)		Yes

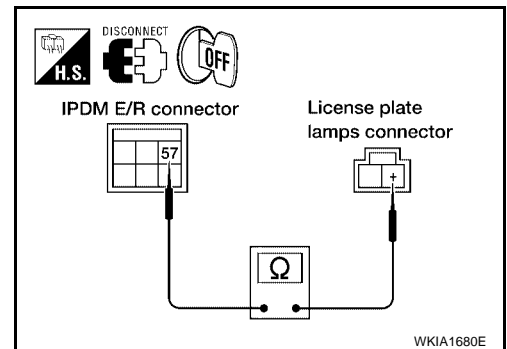

5. Check continuity between IPDM E/R harness connector and rear combination lamp harness connector.

Terminals					Continuity
IPDM E/R		Rear combination lamp			
Connector	Terminal (Wire color)	Connector	Terminal (Wire color)		
E124	57 (R/L)	RH	C14	6 (R/L)	Yes
		LH	C13		

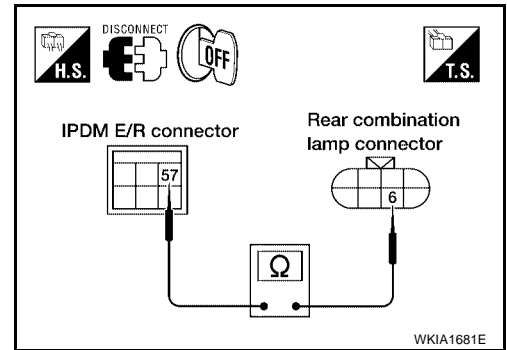

OK or NG

- OK >> Replace IPDM E/R.
- NG >> Repair harness or connector.

A
B
C
D
E
F
G
H
I
J
LT
L
M

PARKING, LICENSE PLATE AND TAIL LAMPS

6. CHECK GROUND

1. Check continuity between front combination lamp harness connector and ground.

Terminals			Ground	Continuity
Front combination lamp		Terminal (Wire color)		
Connector				
RH	E107	4 (B)		Yes
LH	E11			

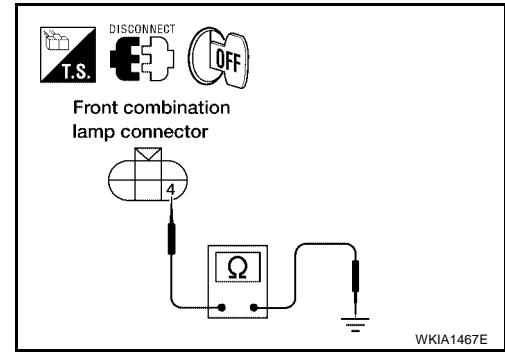

2. Check continuity between license plate lamps harness connector and ground.

Terminals			Ground	Continuity
License plate lamps		Terminal (Wire color)		
Connector				
C12		- (B)		Yes

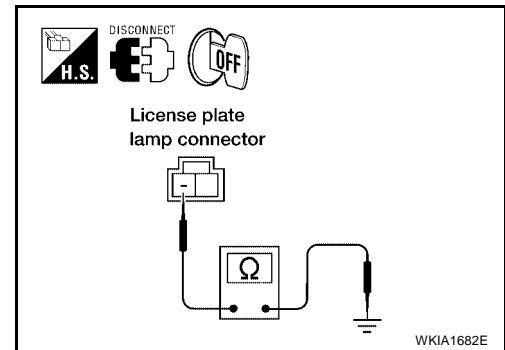

3. Check continuity between rear combination lamp harness connector and ground.

Terminals			Ground	Continuity
Rear combination lamp		Terminal (Wire color)		
Connector				
RH	C14	1 (B)		Yes
LH	C13			

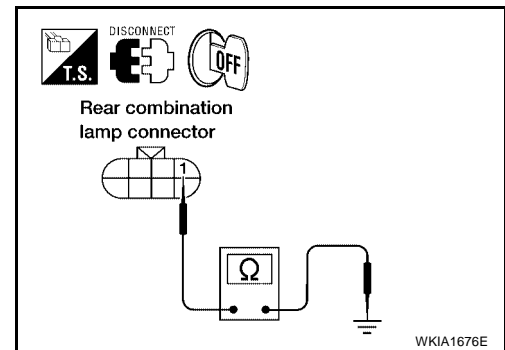

OK or NG

- OK >> Check bulbs.
- NG >> Repair harness or connector.

Parking, License Plate and Tail Lamps Do Not Turn OFF (After Approx. 10 Minutes)

EKS00763

1. CHECK IPDM E/R

1. Turn ignition switch ON. Turn the combination switch (lighting switch) to the OFF position. Turn ignition switch OFF.
2. Verify that the parking, license plate, and tail lamps turn on and off after approximately 10 minutes.

OK or NG

- OK >> Ignition relay malfunction. Refer to [PG-17, "Function of Detecting Ignition Relay Malfunction"](#).
- NG >> INSPECTION END.

PARKING, LICENSE PLATE AND TAIL LAMPS

Front Parking Lamp BULB REPLACEMENT

EKS00764

For bulb replacement, refer to [LT-32, "FRONT TURN SIGNAL/PARKING LAMP"](#) .

Tail Lamp BULB REPLACEMENT

EKS00765

For bulb replacement, refer to [LT-122, "Bulb Replacement"](#) .

A

B

C

D

E

F

G

H

I

J

LT

L

M

REAR COMBINATION LAMP

REAR COMBINATION LAMP

PFP:26554

Bulb Replacement

EKS00766

1. Remove rear combination lamp mounting bolts.
2. Pull rear combination lamp to remove from the vehicle.
3. Turn bulb socket counterclockwise and unlock it.
4. Remove bulb.
5. Installation is in the reverse order of removal.

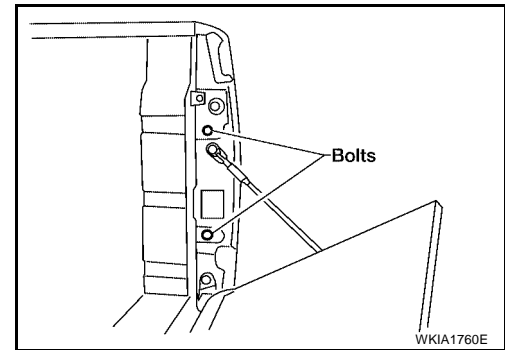

Removal and Installation

EKS00767

1. Remove rear combination lamp mounting bolts.
2. Pull rear combination lamp to remove from the vehicle.
3. Disconnect rear combination lamp connector.

Rear combination lamp mounting bolts : 14.2 N-m (1.4 kg-m, 126 in-lb)

4. Installation is in the reverse order of removal.

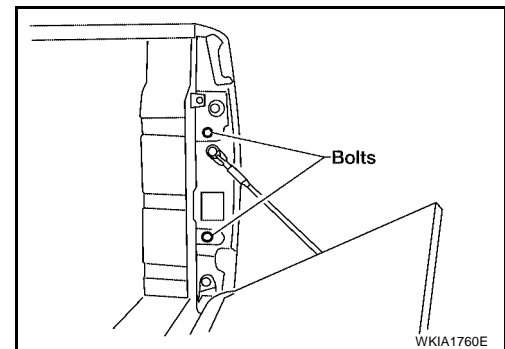

TRAILER TOW

PF9:93020

EKS00768

TRAILER TOW

Component Parts and Harness Connector Location

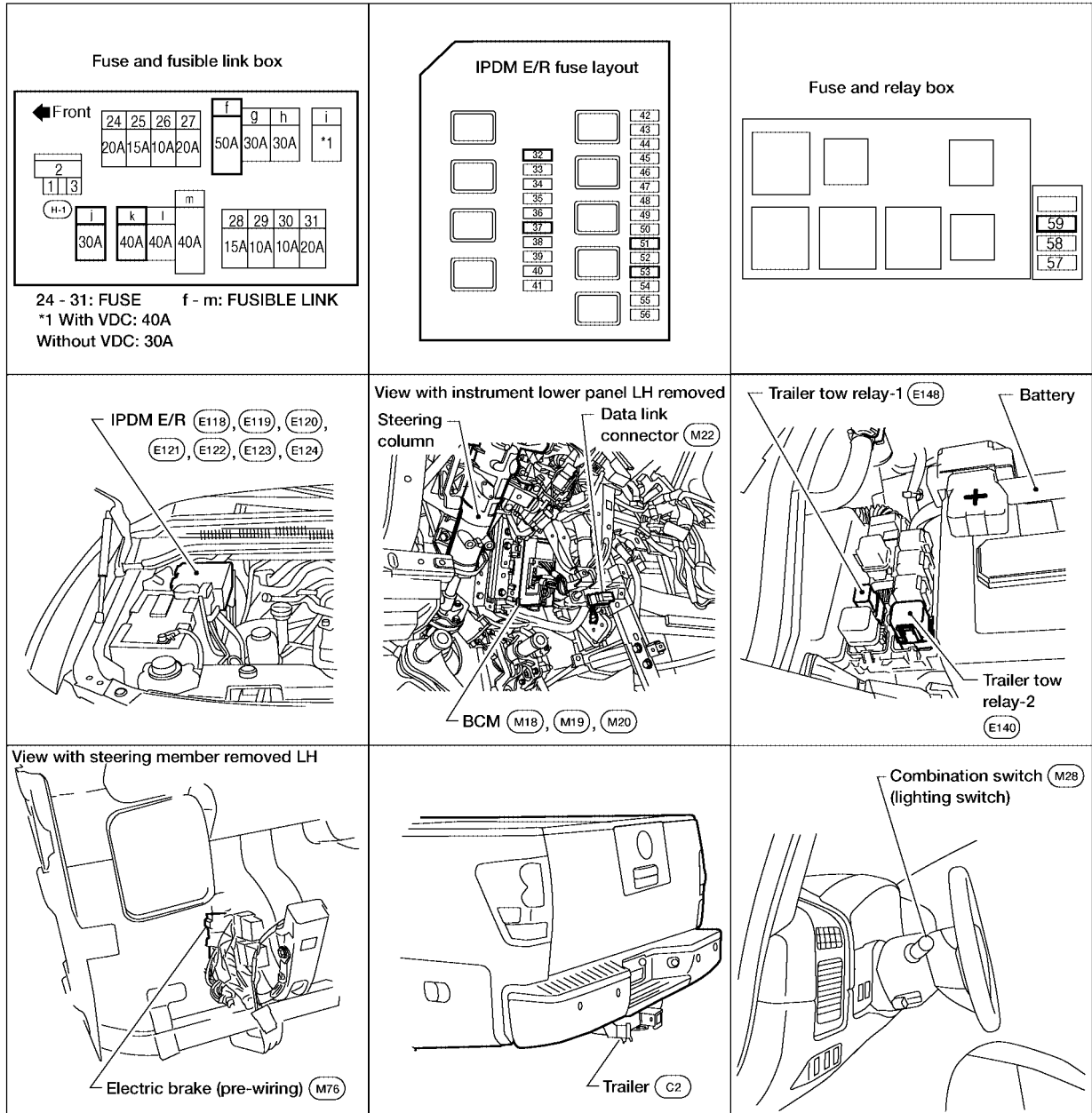

A
B
C
D
E
F
G
H
I
J
LT
L
M

TRAILER TOW

EKS00769

System Description

Power is supplied at all times

- through 50A fusible link (letter **f** , located in the fuse and fusible link box)
- to BCM (body control module) terminal 70
- through 10A fuse [No. 32, located in the IPDM E/R (intelligent power distribution module engine room)]
- to trailer tow relay 1 terminal 5
- through 20A fuse (No. 53, located in the IPDM E/R)
- to IPDM E/R CPU and
- to tail lamp relay, located in the IPDM E/R
- through 30A fusible link (letter **j** , located in the fuse and fusible link box)
- to trailer tow relay 2 terminals 3 and 6
- through 40A fusible link (letter **k** , located in the fuse and fusible link box)
- to electric brake terminal 5.

With the ignition switch in the ON or START position, power is supplied

- through 10A fuse (No. 59, located in the fuse and relay box)
- to BCM terminal 38
- through 10A fuse (No. 51, located in the IPDM E/R)
- to trailer tow relay 2 terminal 1

Ground is supplied

- to BCM terminal 67 and
- to electric brake terminal 1
- through body grounds M57, M61 and M79
- to IPDM E/R terminals 38 and 59
- to trailer tow relay 1 terminal 2
- to trailer tow relay 2 terminal 2, and
- to trailer 7-pin connector terminal 2
- through body grounds E9, E15 and E24.

TRAILER TAIL LAMP OPERATION

The trailer tail lamps are controlled by the trailer tow relay 1.

With the lighting switch in the parking and tail lamp ON (1ST) position, AUTO position (and the auto light system is activated) or headlamp ON (2ND) position, power is supplied

- from the tail lamp relay through 10A fuse (No. 37, located in the IPDM E/R)
- to IPDM E/R terminal 57
- to trailer tow relay 1 coil terminal 1.

When energized, trailer tow relay 1 supplies tail lamp power to trailer 7-pin connector terminal 6.

TRAILER TURN SIGNAL AND HAZARD LAMP OPERATION

The trailer turn signal and hazard lamps are controlled by the BCM. If either turn signal or the hazard lamps are turned on, the BCM supplies voltage to the trailer lamps to make them flash.

Left turn signal and hazard lamp output is supplied

- to trailer tow 7-pin connector terminal 1
- from BCM terminal 52.

Right turn signal and hazard lamp output is supplied

- to trailer tow 7-pin connector terminal 4
- from BCM terminal 51.

TRAILER STOP LAMP OPERATION

The trailer stop lamps are controlled by the electric brake. The electric brake receives stop lamp switch signal when the brake pedal is pressed.

When the brake pedal is pressed, power is supplied

- to trailer tow 7-pin connector terminal 3

TRAILER TOW

- from electric brake terminal 3.

TRAILER POWER SUPPLY OPERATION

The trailer power supply is controlled by the trailer tow relay 2.

When the ignition switch is in the ON or START position, power is supplied

- from IPDM E/R terminal 16
- to trailer tow relay 2 terminal 1.

When energized, the trailer tow relay 2 supplies power

- from trailer tow relay 2 terminal 5
- to trailer tow 7-pin connector terminal 5.

A

B

C

D

E

F

G

H

I

J

LT

L

M

TRAILER TOW

Schematic

EKS0076A

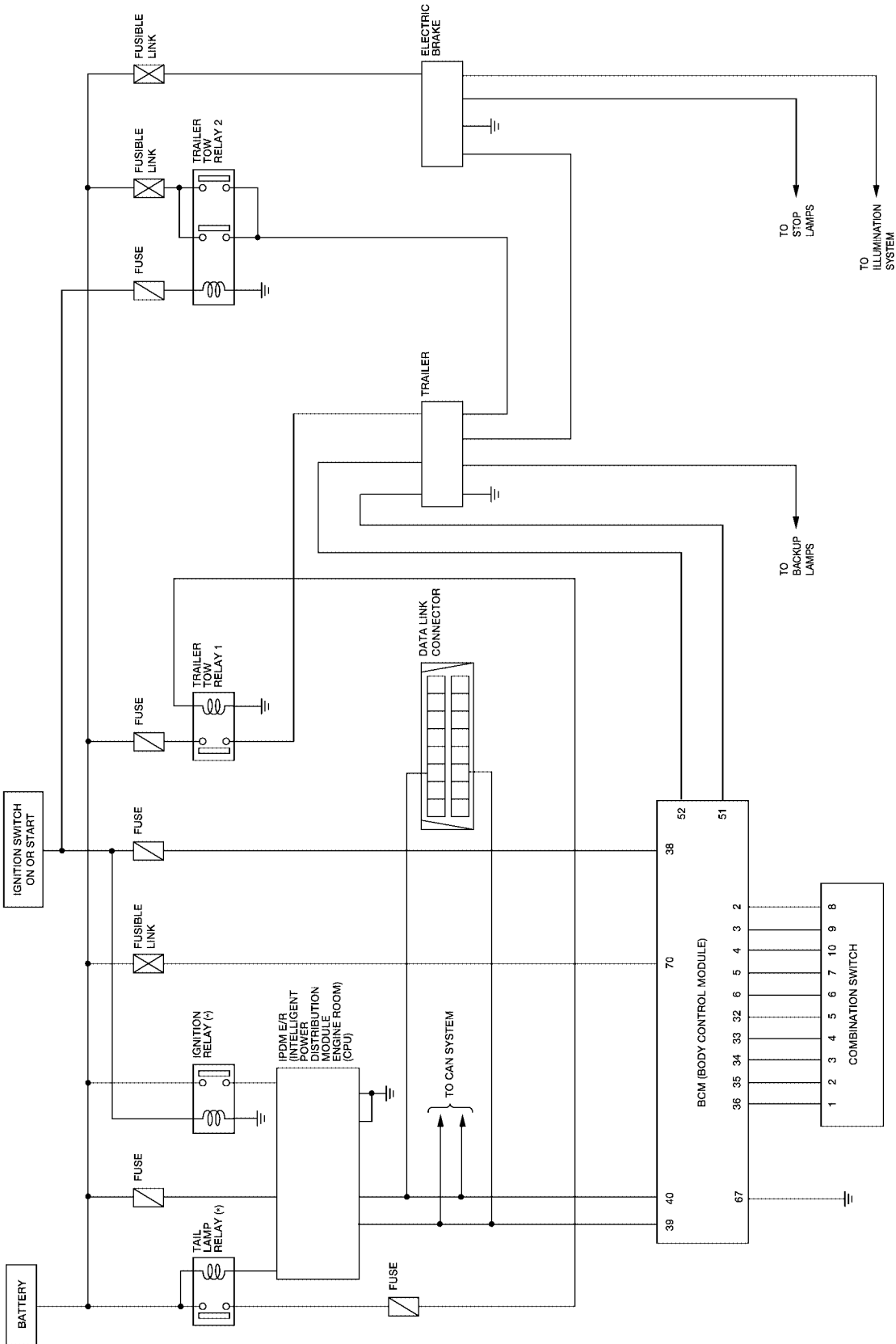

*: THIS RELAY IS BUILT INTO THE IPDM E/R (INTELLIGENT POWER DISTRIBUTION MODULE ENGINE ROOM)

WKWA1074E

TRAILER TOW

EKS0076B

Wiring Diagram — T/TOW —

LT-T/TOW-01

— : DATA LINE

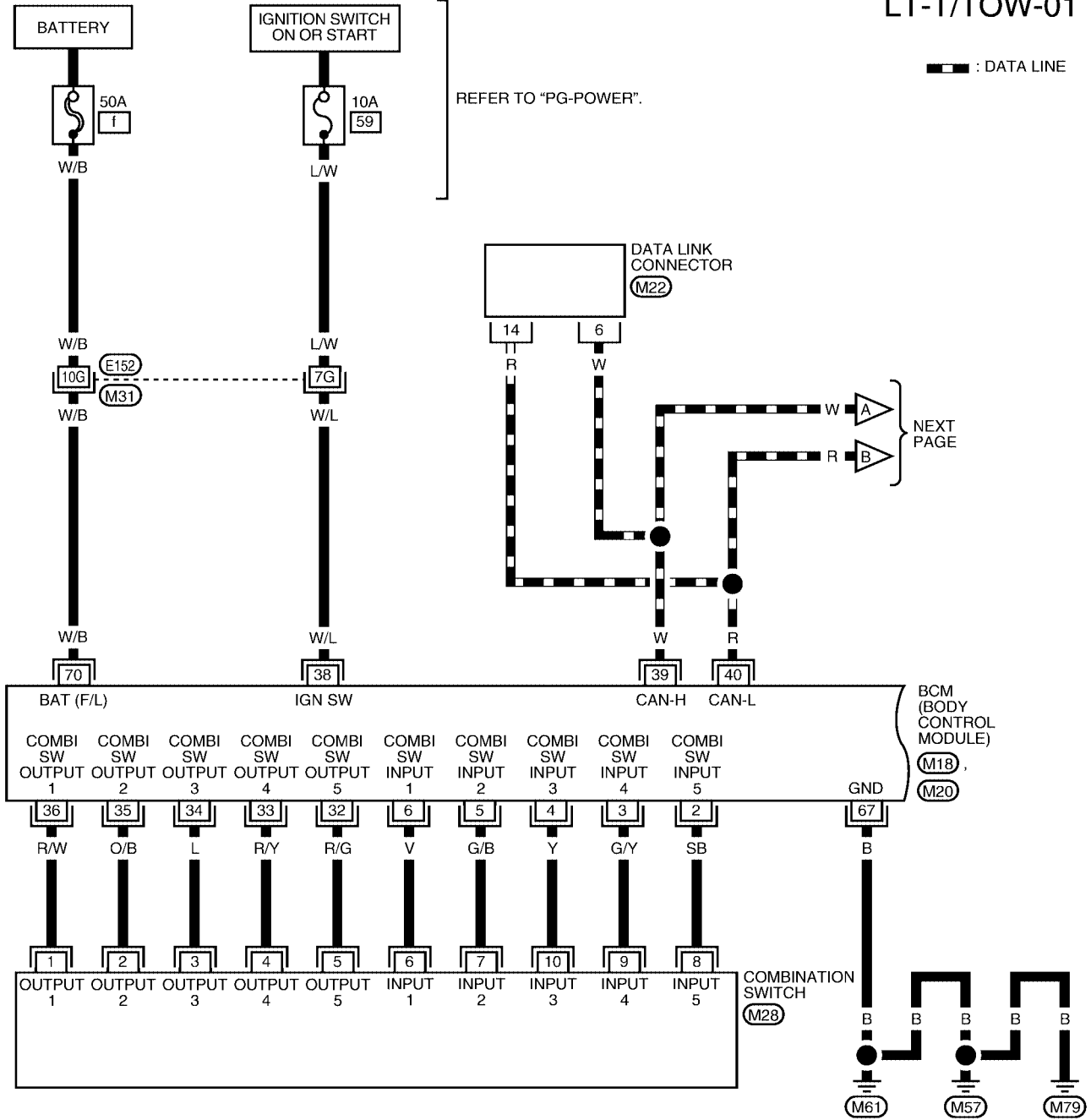

A
B
C
D
E
F
G
H
I
J
LT
L
M

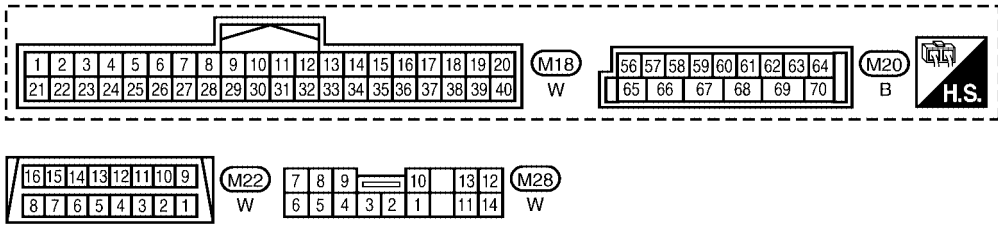

REFER TO THE FOLLOWING.
(M31) - SUPER MULTIPLE JUNCTION (SMJ)

WKWA1160E

TRAILER TOW

LT-T/TOW-02

— : DATA LINE

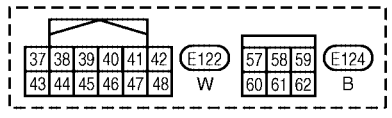
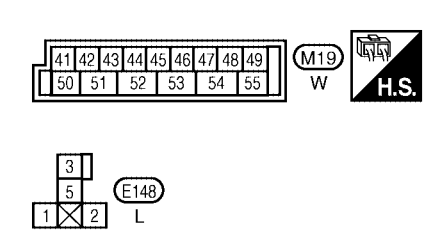
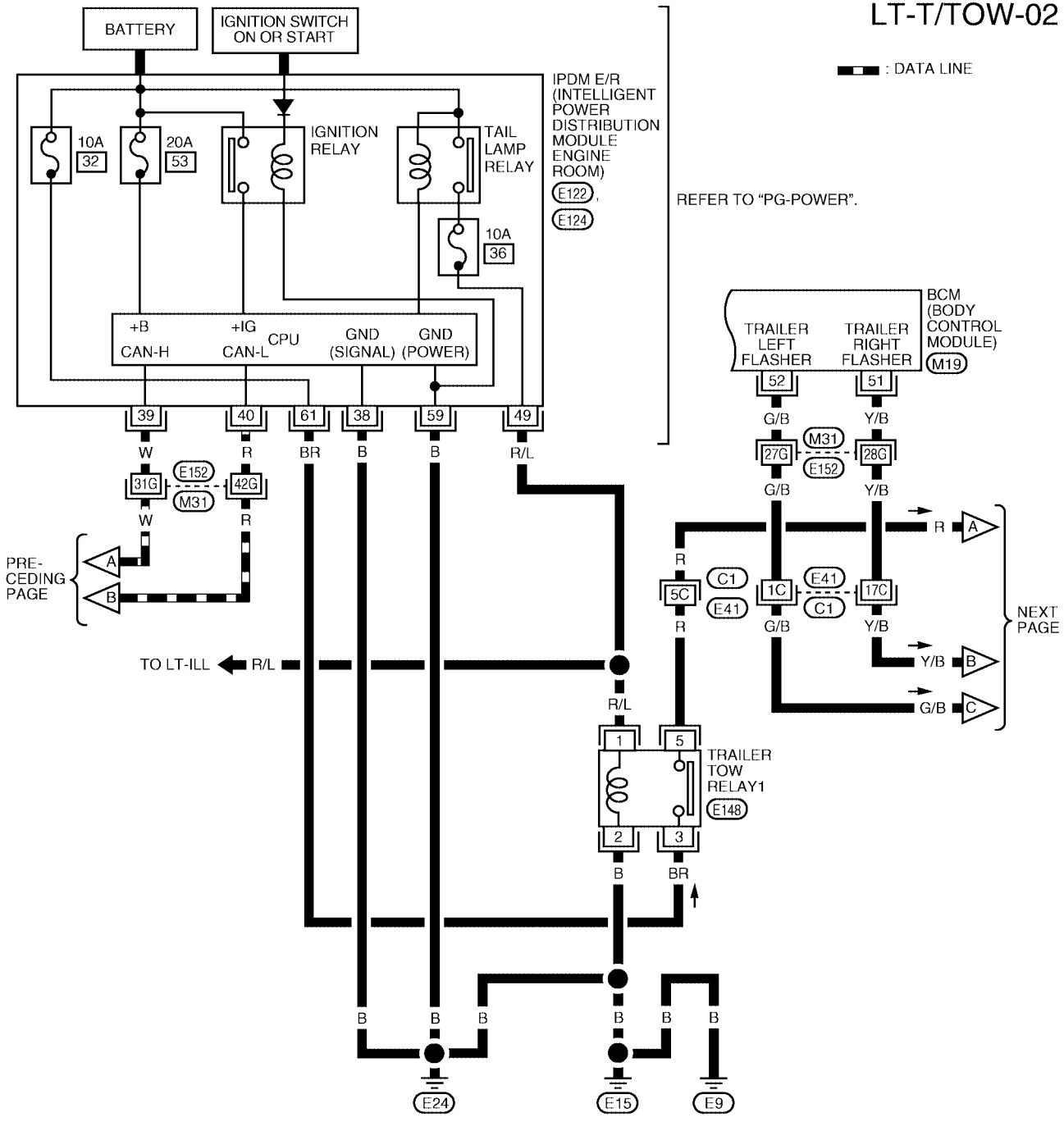

REFER TO THE FOLLOWING.
 (M31), (C1) - SUPER MULTIPLE JUNCTION (SMJ)

WKWA1210E

TRAILER TOW

LT-T/TOW-03

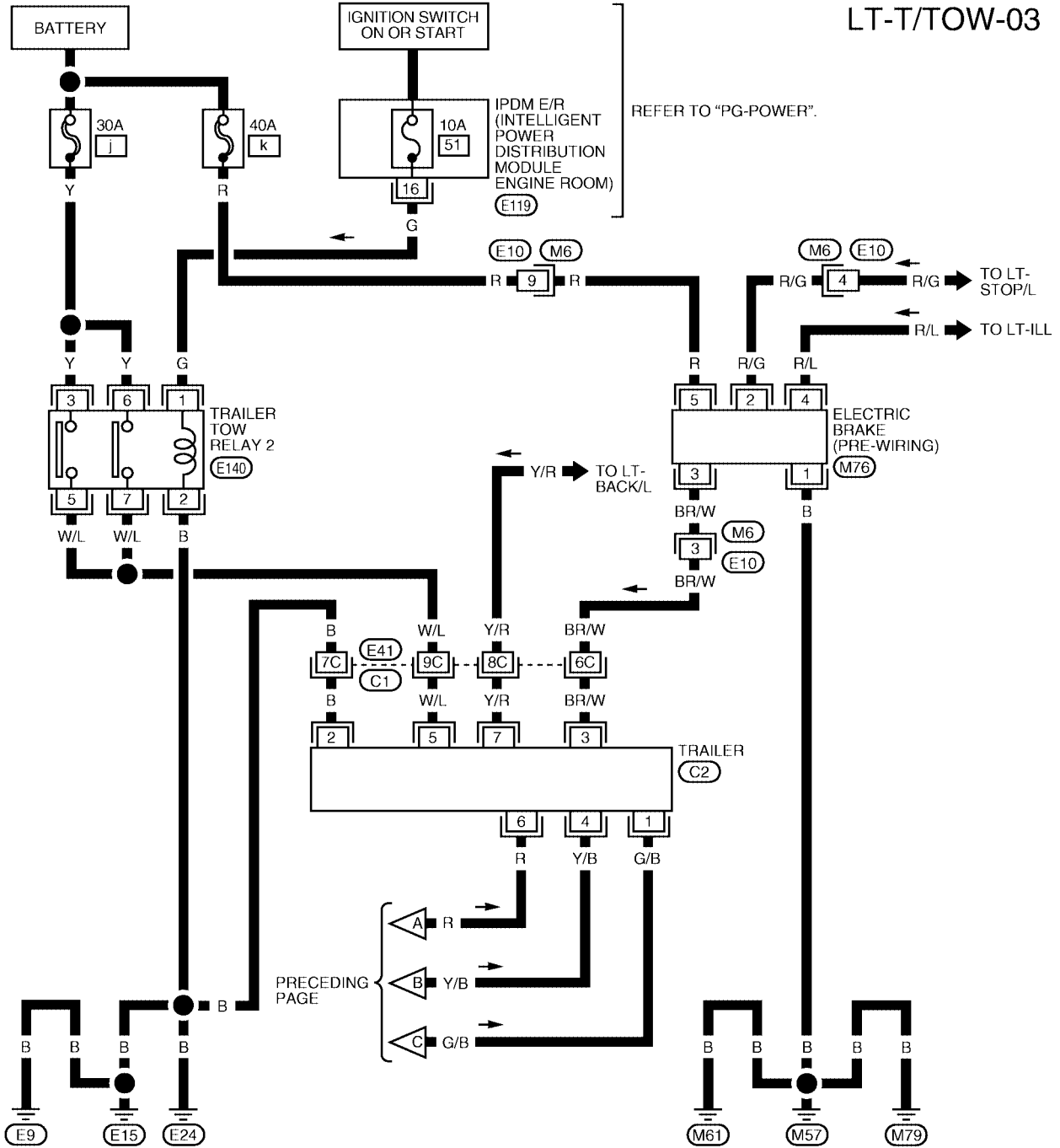

A
B
C
D
E
F
G
H
I
J
LT
L
M

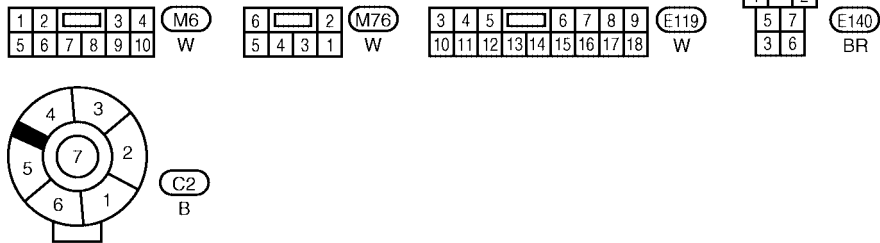

REFER TO THE FOLLOWING.
 (C1) - SUPER MULTIPLE JUNCTION (SMJ)

WKWA1405E

INTERIOR ROOM LAMP

INTERIOR ROOM LAMP

PF2:26410

Component Parts and Harness Connector Location

EKS0076C

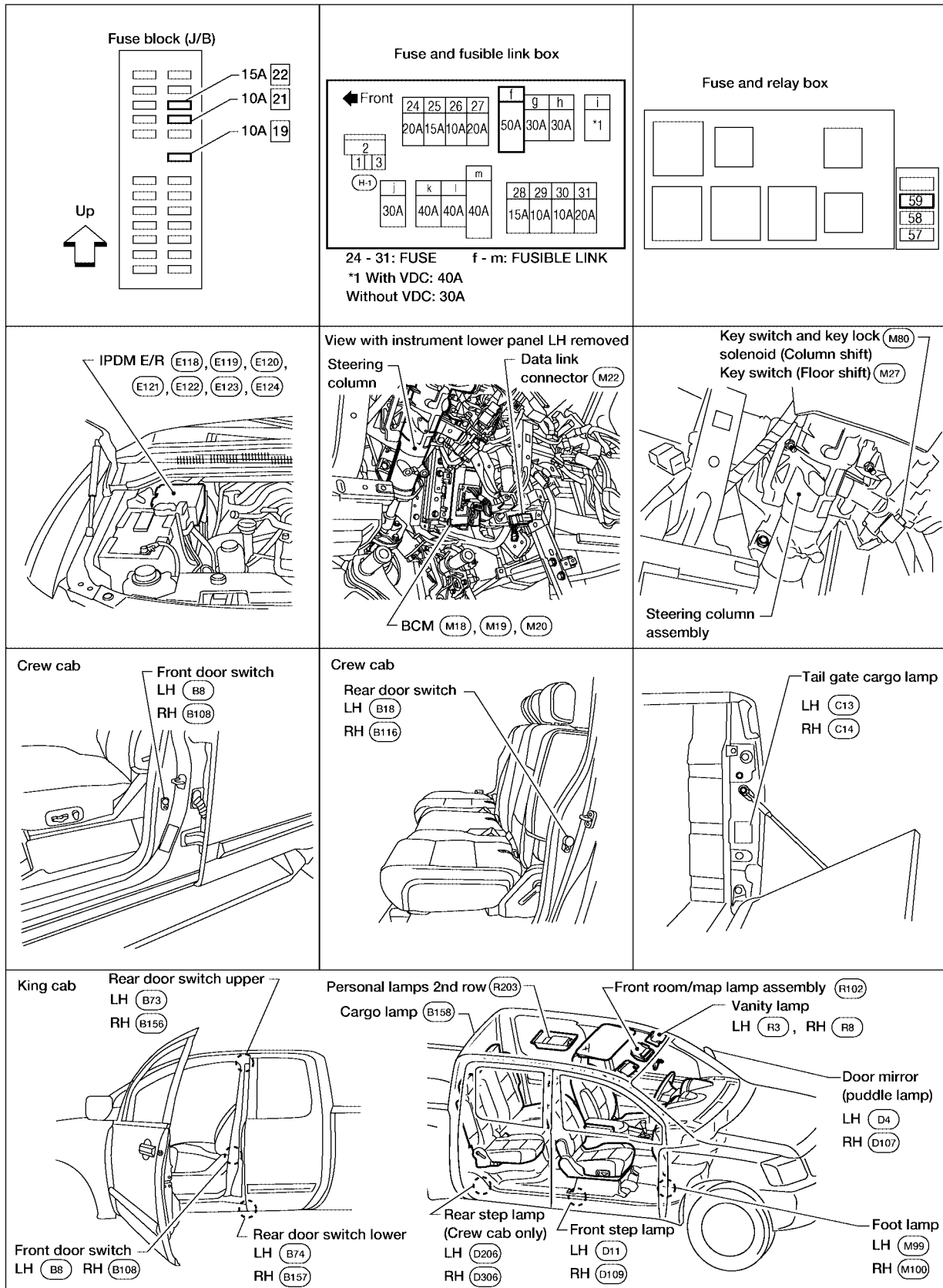

WKIA2835E

INTERIOR ROOM LAMP

EKS0076D

System Description

When room lamp and personal lamp switch is in DOOR position, room lamp and personal lamp ON/OFF is controlled by timer according to signals from switches including key switch (with column shift) or key switch and key lock solenoid (with floor shift), front door switch driver side, unlock signal from keyfob, door lock and unlock switch, key cylinder lock and unlock switch, ignition switch.

When room lamp and personal lamp turns ON, there is a gradual brightening over 1 second. When room lamp and personal lamp turns OFF, there is a gradual dimming over 1 second.

The room lamp and personal lamp timer is controlled by the BCM (body control module).

Room lamp and personal lamp timer control settings can be changed with CONSULT-II.

Step and foot lamp turns ON when driver door, passenger or rear doors are opened (door switch ON). Lamp turns OFF when driver, passenger and rear doors are closed (all door switches OFF).

POWER SUPPLY AND GROUND

Power is supplied at all times

- through 10A fuse [No. 19, located in the fuse block (J/B)]
- to key switch terminal 3
- through 15A fuse [No. 22, located in the fuse block (J/B)]
- to BCM terminal 57
- through 50A fusible link (letter f , located in the fuse and fusible link box)
- to BCM terminal 70.
- through 10A fuse [No. 21, located in the fuse block (J/B)]
- to cargo lamp relay terminals 1 and 3.

When the key is inserted in key switch (with column shift) or key switch and key lock solenoid (with floor shift), power is supplied

- through the key switch (with column shift) or key switch and key lock solenoid (with floor shift) terminal 4
- to BCM terminal 37.

With the ignition switch in the ON or START position, power is supplied

- through 10A fuse (No. 59, located in the fuse and relay box)
- to BCM terminal 38.

Ground is supplied

- to BCM terminal 67
- through grounds M57, M61 and M79.

When the front driver side door is opened, ground is supplied

- through case ground of front door switch LH (crew cab) or
- through grounds B7 and B19 (king cab)
- to BCM terminal 47.

When the front passenger side door is opened, ground is supplied

- through case ground of front door switch RH (crew cab) or
- through grounds B117 and B132 (king cab)
- to BCM terminal 12.

When the rear door LH (crew cab) is opened, ground is supplied

- through case ground of rear door switch LH
- to BCM terminal 48.

When the rear door LH (king cab) is opened, ground is supplied

- through grounds B7 and B19
- to rear door switch upper LH and rear door switch lower LH terminal 2
- from rear door switch upper LH and rear door switch lower LH terminal 1
- to BCM terminal 47.

When the rear door RH (crew cab) is opened, ground is supplied

- through case ground of rear door switch RH
- to BCM terminal 13.

A

B

C

D

E

F

G

H

I

J

LT

L

M

INTERIOR ROOM LAMP

When the rear door RH (king cab) is opened, ground is supplied

- through grounds B117 and B132
- to rear door switch upper RH and rear door switch lower RH terminal 2
- from rear door switch upper RH and rear door switch lower RH terminal 1
- to BCM terminal 12.

When the front driver or front passenger side door is unlocked by the door lock and unlock switch, BCM receives serial data

- through grounds M57, M61 and M79
- to main power window and door lock/unlock switch terminal 14 (crew cab) or 12 (king cab) and power window and door lock/unlock switch RH terminal 16
- to BCM terminal 22.

When the front driver side door is unlocked by the key, the BCM receives serial data

- through grounds M57, M61 and M79
- to front door key cylinder switch LH terminal 5
- from front door key cylinder switch LH terminal 6
- to main power window and door lock/unlock switch terminal 6 (crew cab) or 7 (king cab)
- from main power window and door lock/unlock switch terminal 14 (crew cab) or 12 (king cab)
- to BCM terminal 22.

When a signal, or combination of signals is received by the BCM, ground is supplied

- through BCM terminal 63
- to door mirror LH and RH terminal 13 (with puddle lamps)
- to front room/map lamp assembly terminal 1
- through front room/map lamp assembly terminal 2
- to personal lamps 2nd row terminal 1 (with rear overhead console).

With power and ground supplied, the lamps illuminate.

SWITCH OPERATION

When any door switch is ON (door is opened), ground is supplied

- through BCM terminal 62
- to front and rear step lamps LH and RH and foot lamp LH and RH (with foot lamps) terminal -.

And power is supplied

- from BCM terminal 56
- to front and rear step lamps LH and RH terminal +, door mirror LH and RH terminal 12 (with puddle lamps), front room/map lamp assembly terminal 6, vanity lamps terminal 1 (with vanity lamps), personal lamps 2nd row terminal 3 (with rear overhead console), room lamp terminal 2 and foot lamp LH and RH terminal + (with foot lamps).

When front room/map lamp assembly switch is ON, ground is supplied

- through grounds M57, M61 and M79
- to front room/map lamp assembly terminal 5.

When vanity mirror lamp (driver side and passenger side) is ON, ground is supplied

- through grounds M57, M61 and M79
- to vanity mirror lamp (driver side and passenger side) terminal 2.

When cargo lamp switch is ON, ground is supplied

- through grounds M57, M61 and M79
- to cargo lamp switch terminal 3
- through cargo lamp switch terminal 1
- to BCM terminal 31.

ROOM LAMP TIMER OPERATION

When lamp switch is in DOOR position, and when all conditions below are met, BCM performs timer control (maximum 30 seconds) for interior room lamp and map lamp ON/OFF.

Power is supplied

INTERIOR ROOM LAMP

- from 10A fuse [No. 19, located in the fuse block (J/B)]
- to key switch terminal 3.

Key is removed from key switch (with column shift) or key switch and key lock solenoid (with floor shift) (key switch OFF), power will not be supplied to BCM terminal 37.

Serial data is supplied

- from BCM terminal 22
- to power window main switch (door lock and unlock switch) terminal 14 (crew cab) or 12 (king cab).

At the time that driver door is opened, BCM detects that driver door is unlocked. It determines that interior room lamp and map lamp timer operation conditions are met, and turns the interior room lamps ON for 30 seconds.

Key is in key switch (with column shift) or key switch and key lock solenoid (with floor shift) (key switch ON), Power is supplied

- through key switch (with column shift) or key switch and key lock solenoid (with floor shift) terminal 4
- to BCM terminal 37.

When key is removed from key switch (with column shift) or key switch and key lock solenoid (with floor shift) (key switch OFF), power supply to BCM terminal 37 is terminated. BCM detects that key has been removed, determines that interior room lamp and map lamp timer conditions are met, and turns the interior room lamps ON for 30 seconds.

When driver door opens → closes, and the key is not inserted in the key switch (with column shift) or key switch and key lock solenoid (with floor shift) (key switch OFF), BCM terminal 47 changes between 0V (door open) → 12V (door closed). The BCM determines that conditions for interior room lamp operation are met and turns the interior room lamp ON for 30 seconds.

Timer control is canceled under the following conditions.

- Driver door is locked [when locked with keyfob, power window main switch (door lock and unlock switch) or door key cylinder switch]
- Driver door is opened (driver door switch turns ON)
- Ignition switch ON.

INTERIOR LAMP BATTERY SAVER CONTROL

If interior lamp is left "ON", it will not be turned off even when door is closed.

BCM turns off interior lamp automatically to save battery 30 minutes after ignition switch is turned off.

BCM controls interior lamps listed below:

- Room lamp
- Vanity mirror lamp
- Front room/map lamp assembly
- Cargo lamp
- Personal lamp 2nd row
- Step lamps
- Puddle lamps
- Foot lamps

After lamps turn OFF by the battery saver system, the lamps illuminate again when

- signal from keyfob, or power window main switch (door lock and unlock switch) or key cylinder is locked or unlocked,
- door is opened or closed,
- key is removed from key switch (with column shift) or key switch and key lock solenoid (with floor shift) or inserted in key switch (with column shift) or key switch and key lock solenoid (with floor shift).

Interior lamp battery saver control period can be changed by the function setting of CONSULT-II.

A

B

C

D

E

F

G

H

I

J

LT

L

M

INTERIOR ROOM LAMP

Schematic

EKS0076E

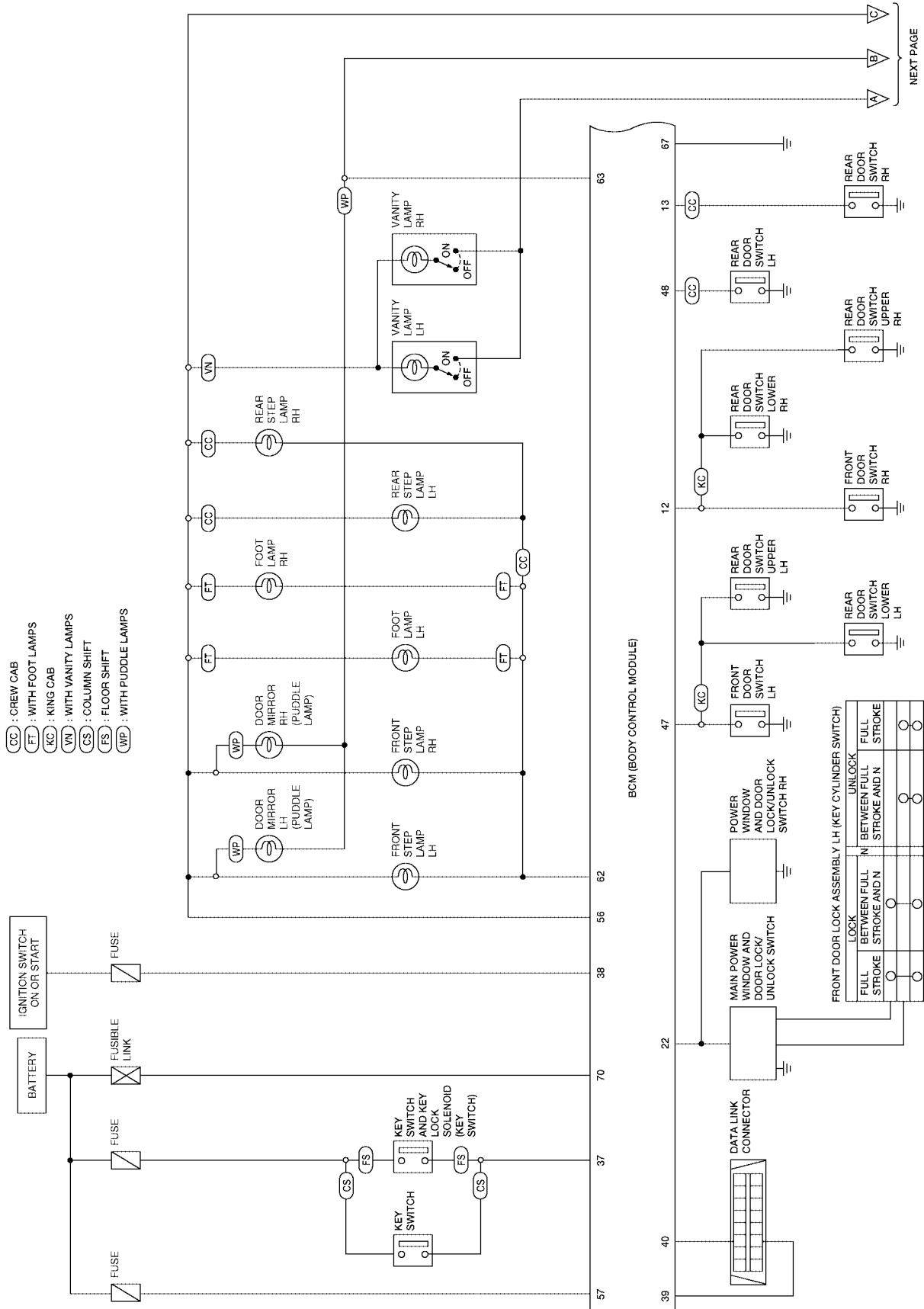

WKWA1511E

INTERIOR ROOM LAMP

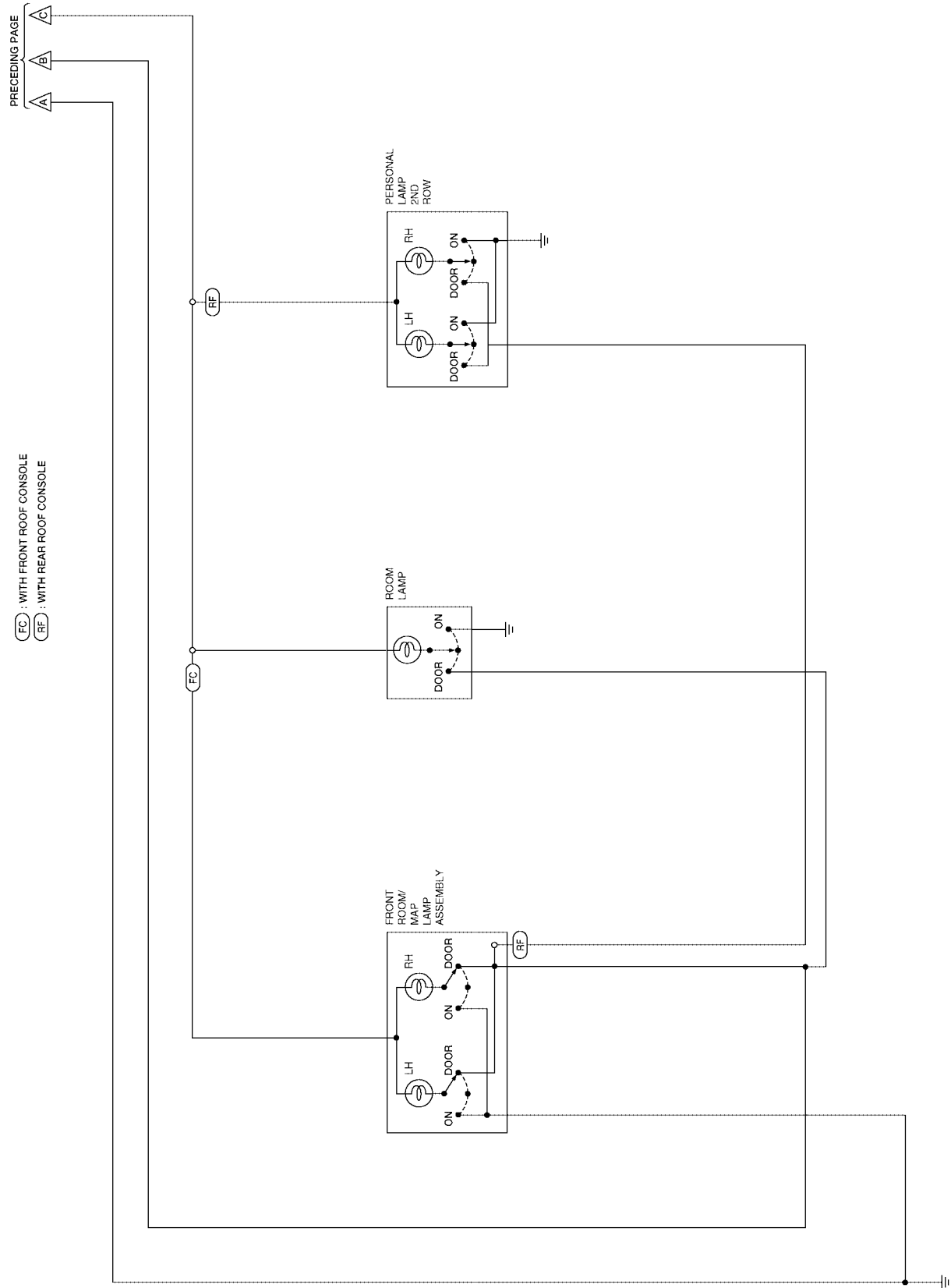

WKWA1563E

INTERIOR ROOM LAMP

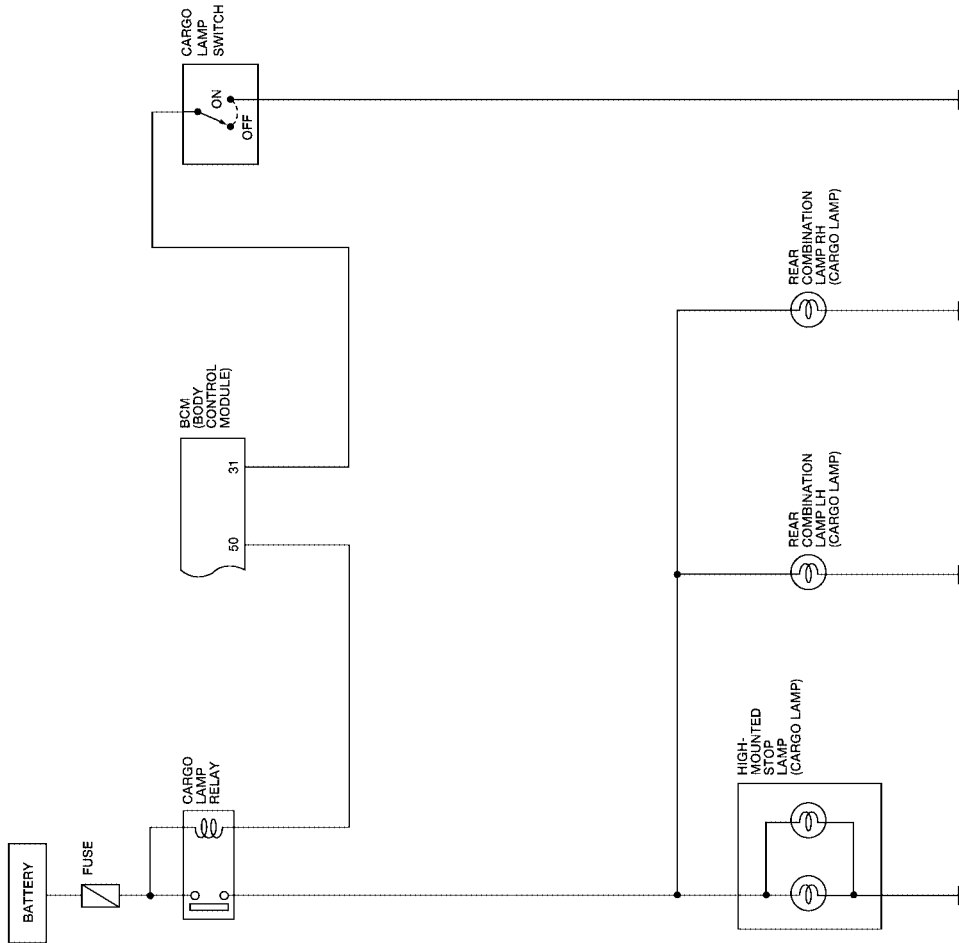

LKWA0285E

INTERIOR ROOM LAMP

Wiring Diagram — INT/L —

EKS0076F

LT-INT/L-01

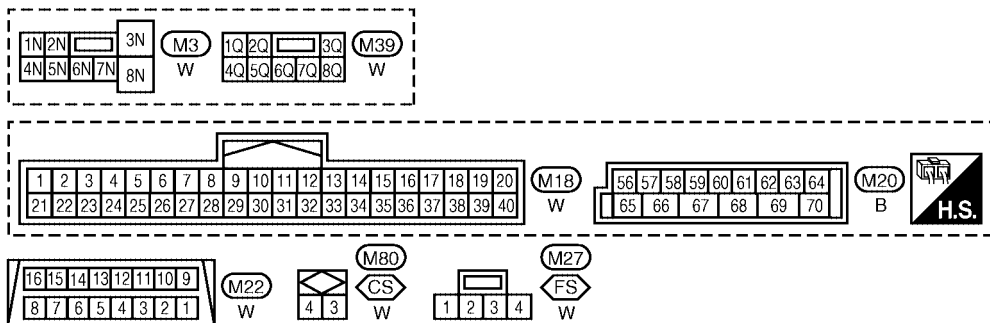
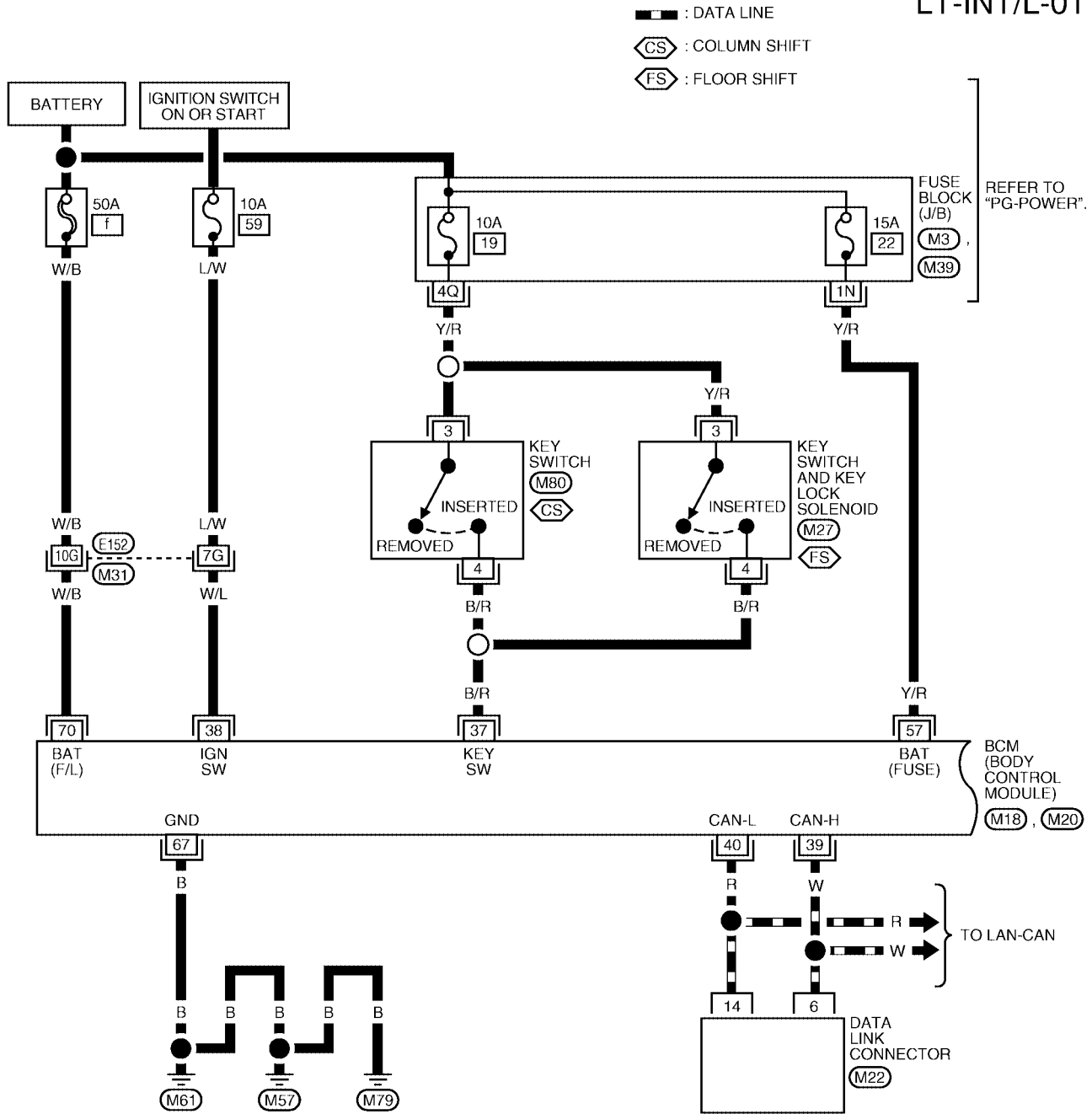

REFER TO THE FOLLOWING.
 (M31) - SUPER MULTIPLE JUNCTION (SMJ)

WKWA1512E

INTERIOR ROOM LAMP

LT-INT/L-02

◻ CC : CREW CAB
◻ KC : KING CAB

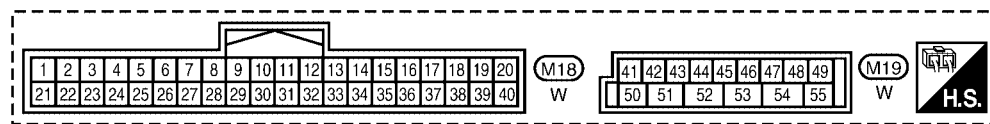
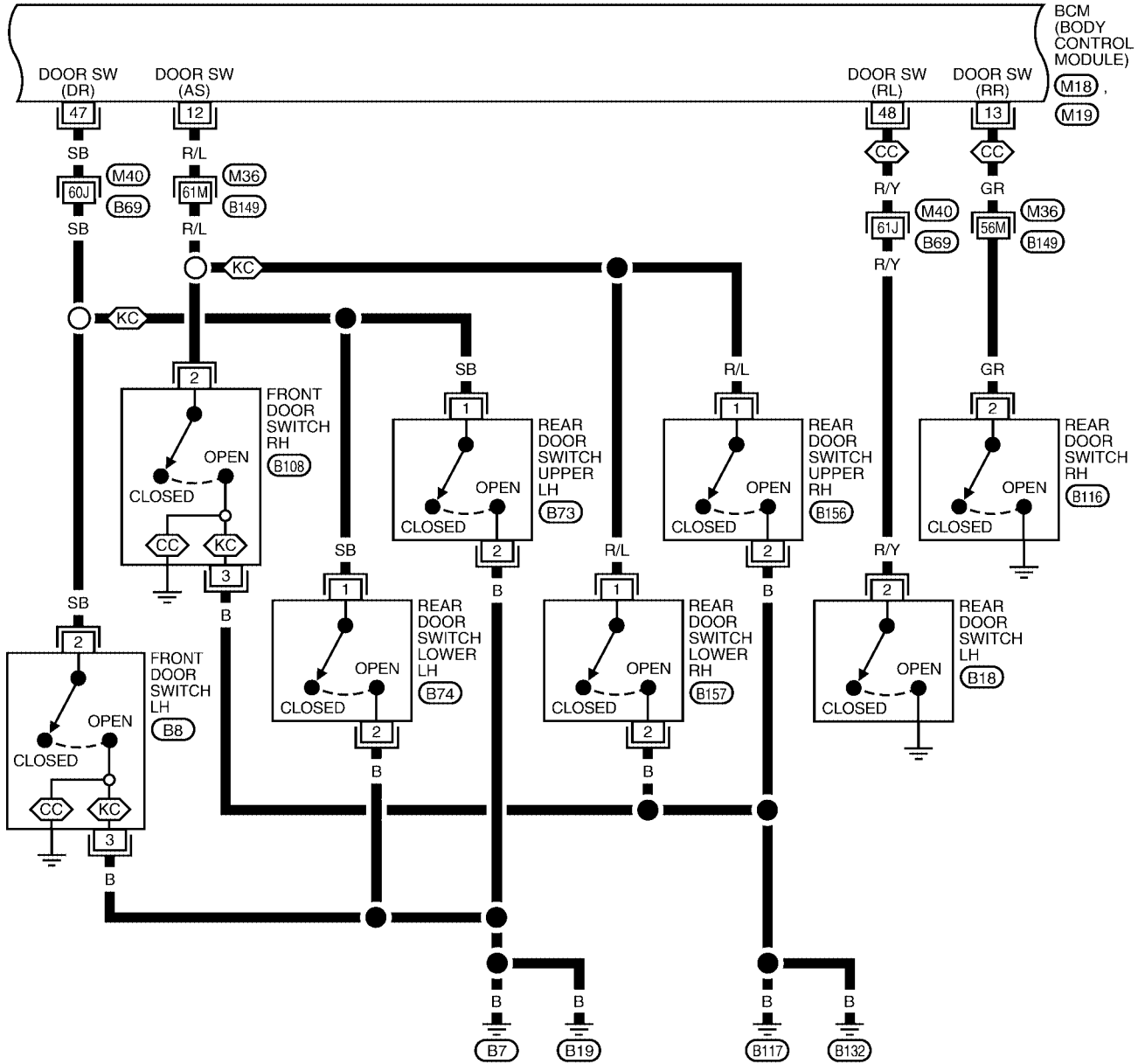

REFER TO THE FOLLOWING.
 (M36), (M40) - SUPER
 MULTIPLE JUNCTION (SMJ)



LKWA0286E

INTERIOR ROOM LAMP

LT-INT/L-03

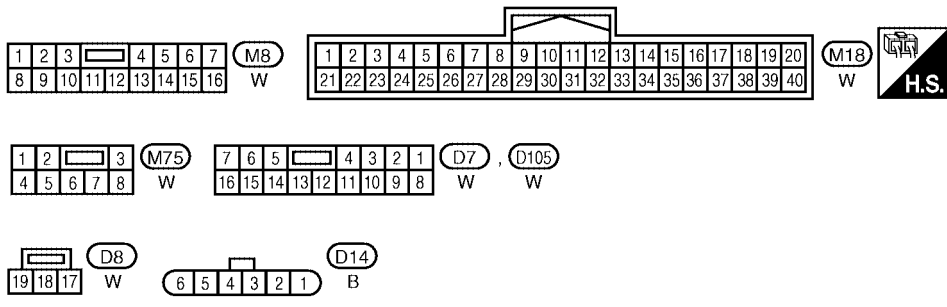
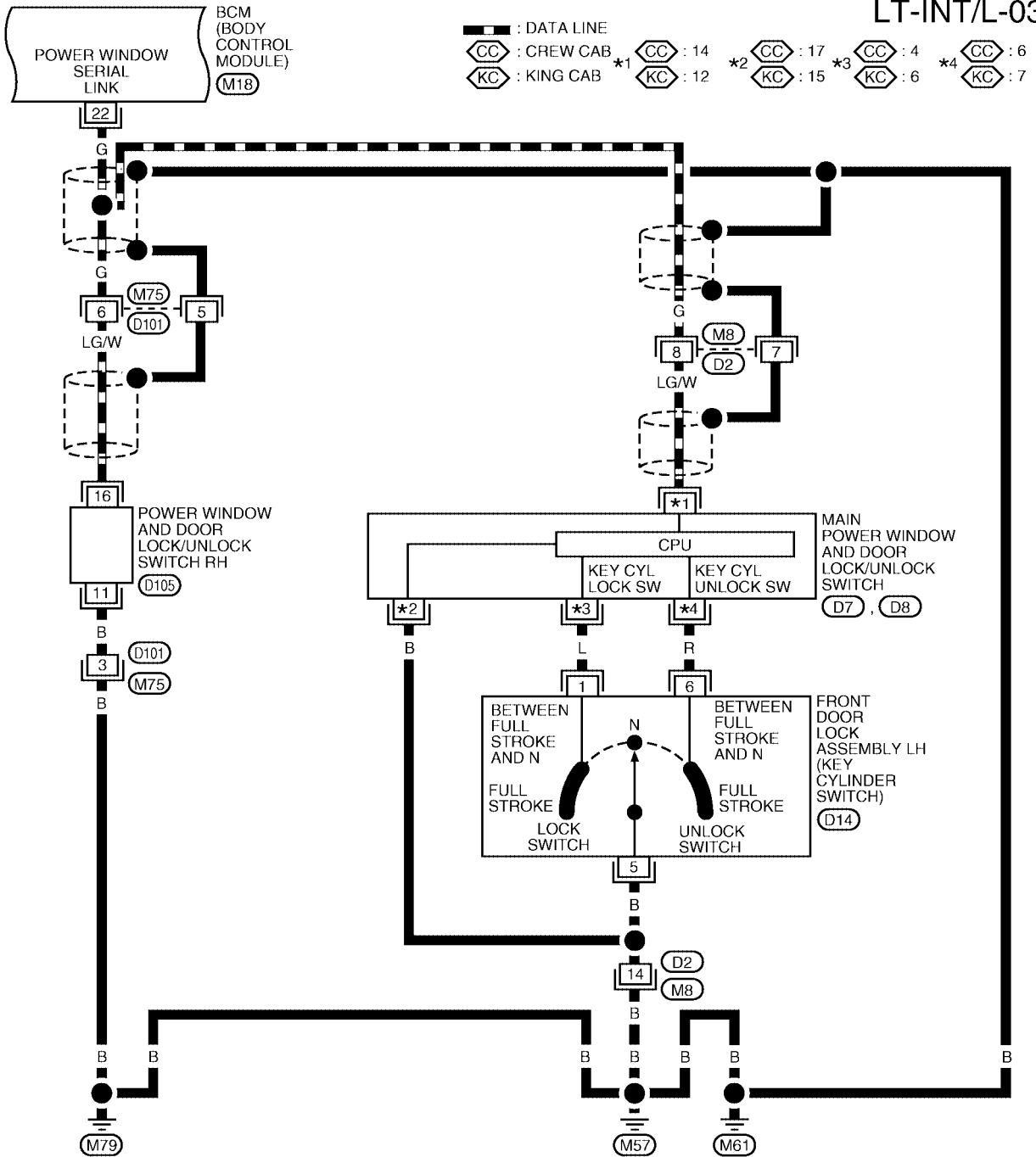

WKWA1505E

INTERIOR ROOM LAMP

LT-INT/L-04

WP : WITH PUDDLE LAMPS

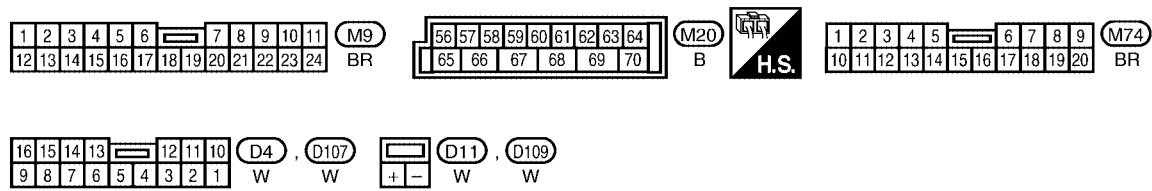
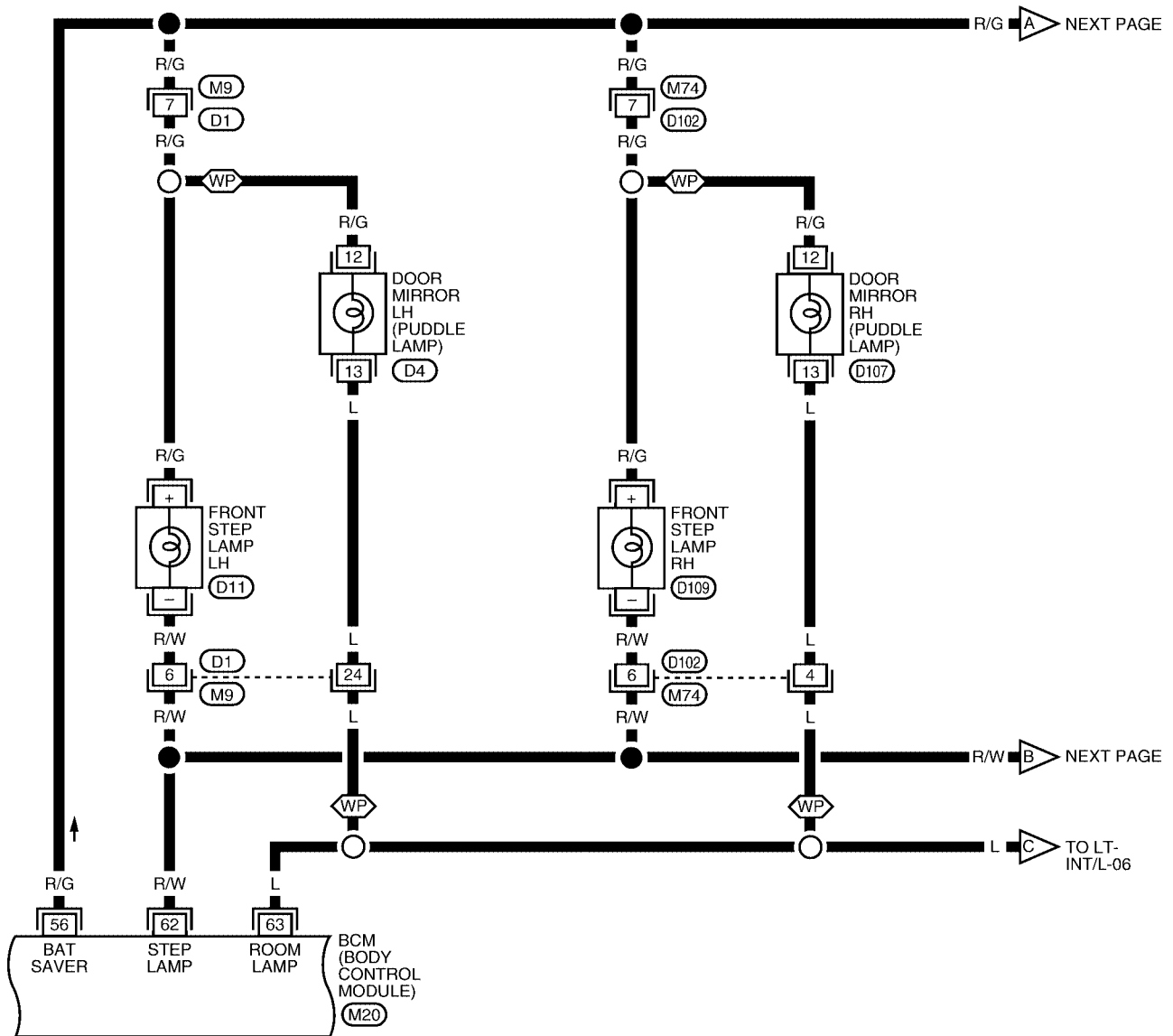

WKWA0754E

INTERIOR ROOM LAMP

LT-INT/L-05

CC : CREW CAB
 FT : WITH FOOT LAMPS

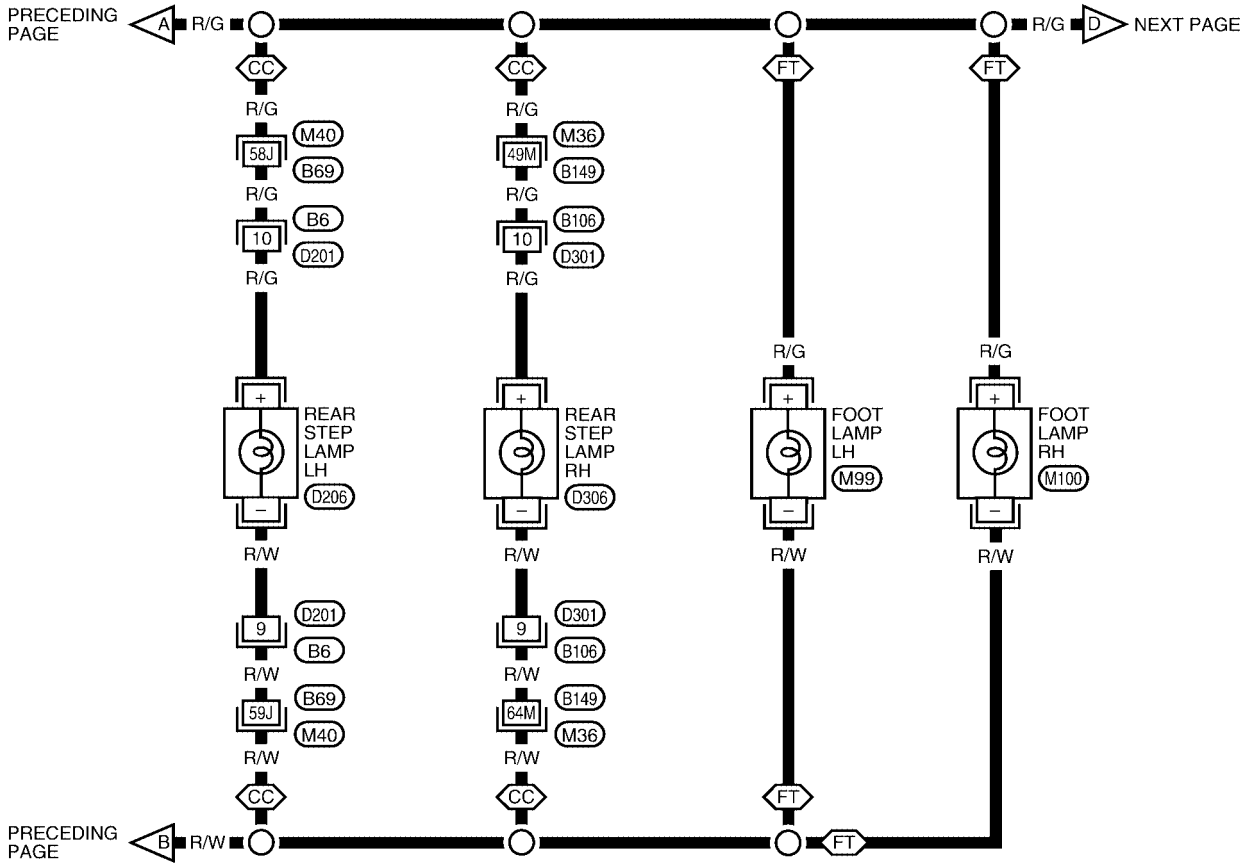

PRECEDING PAGE

REFER TO THE FOLLOWING.
 M36, M40 - SUPER
 MULTIPLE JUNCTION (SMJ)

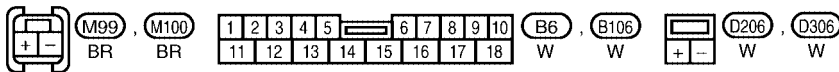

WKWA1083E

INTERIOR ROOM LAMP

LT-INT/L-06

- ⬡FC : WITH FRONT ROOF CONSOLE
- ⬡RF : WITH REAR ROOF CONSOLE
- ⬡VN : WITH VANITY LAMPS

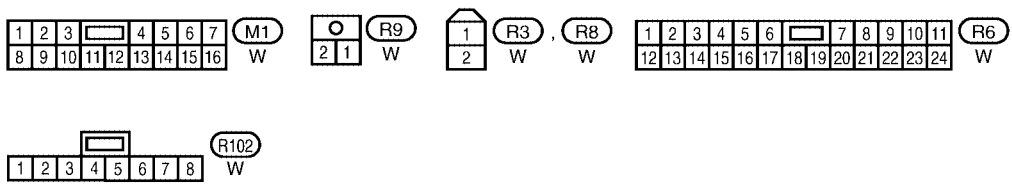
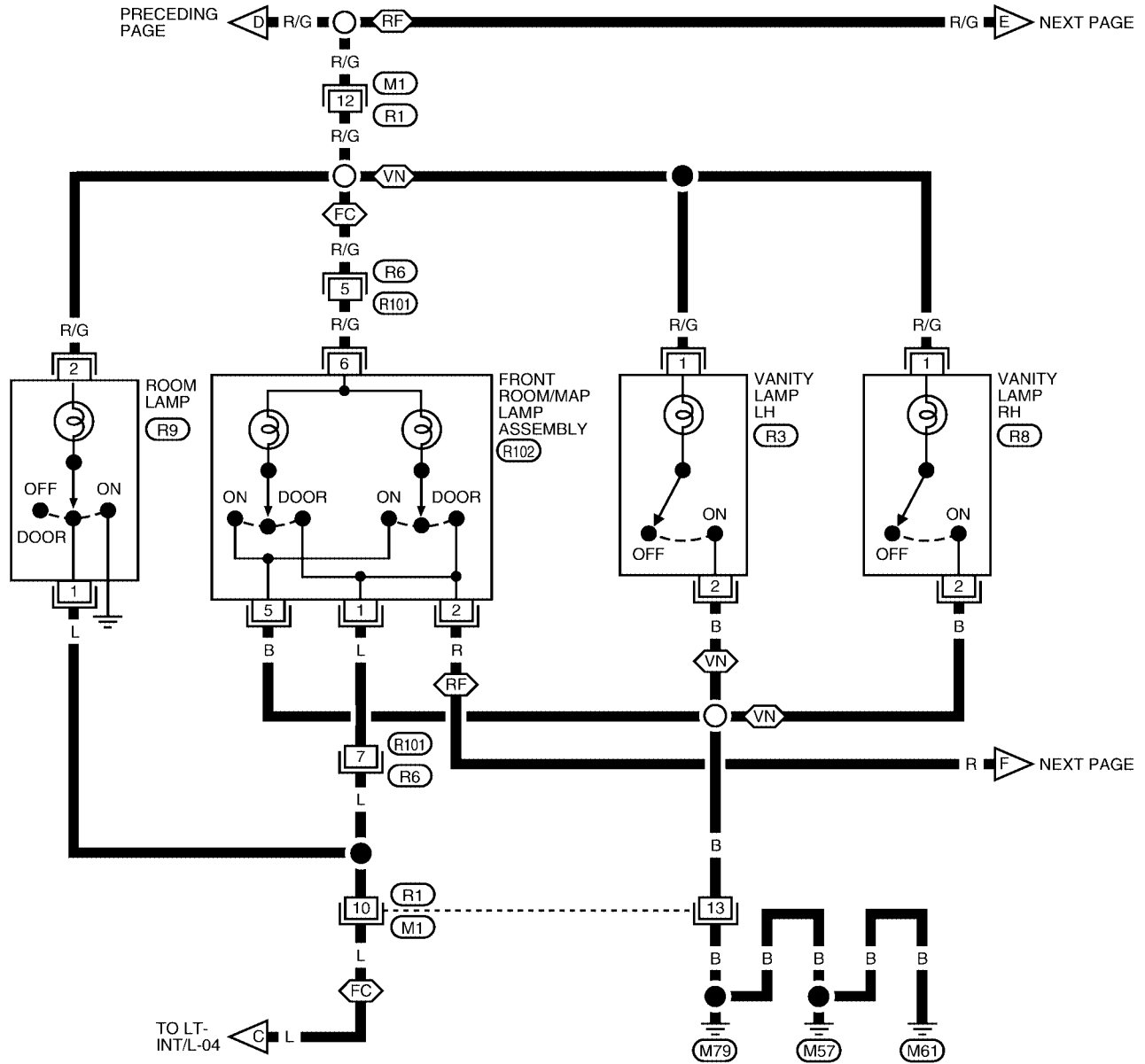

WKWA1084E

INTERIOR ROOM LAMP

LT-INT/L-07

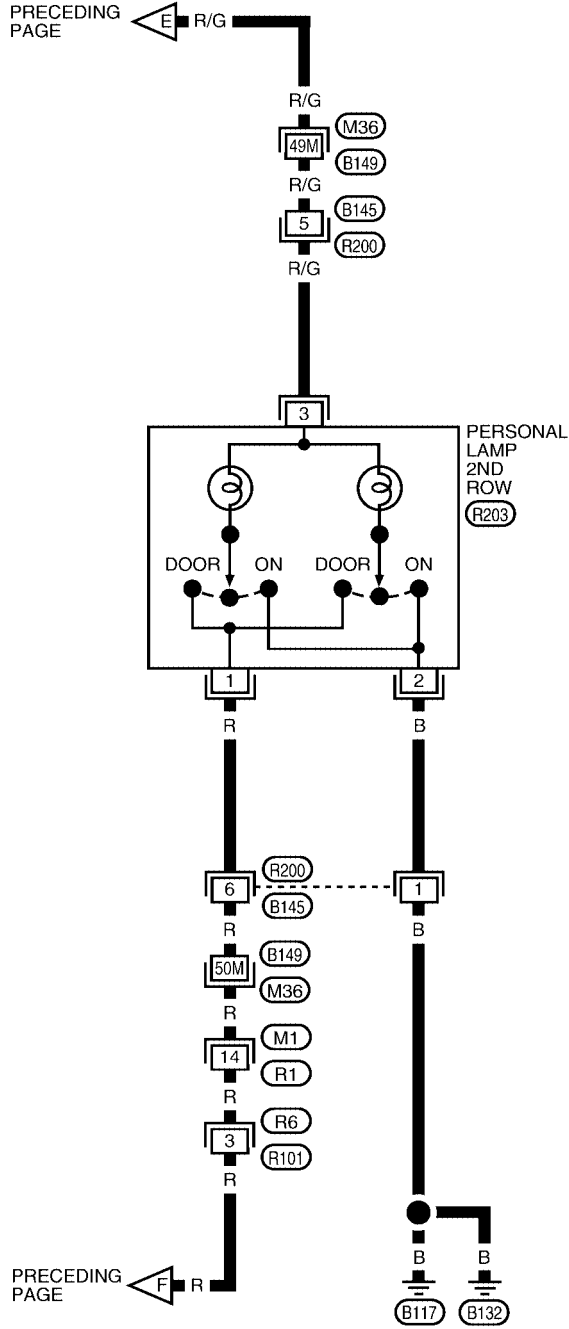

A
B
C
D
E
F
G
H
I
J
LT
L
M

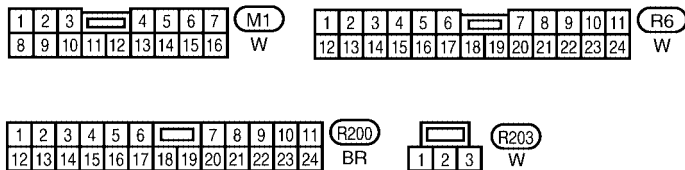

REFER TO THE FOLLOWING.
M36 - SUPER MULTIPLE JUNCTION (SMJ)

LKWA0287E

INTERIOR ROOM LAMP

LT-INT/L-08

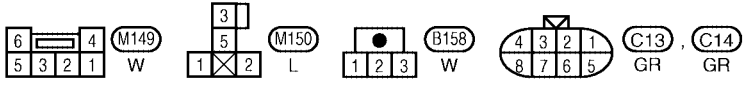
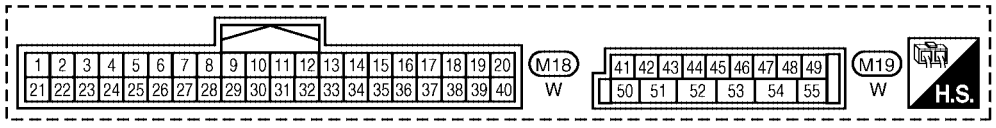
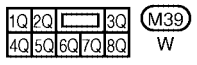
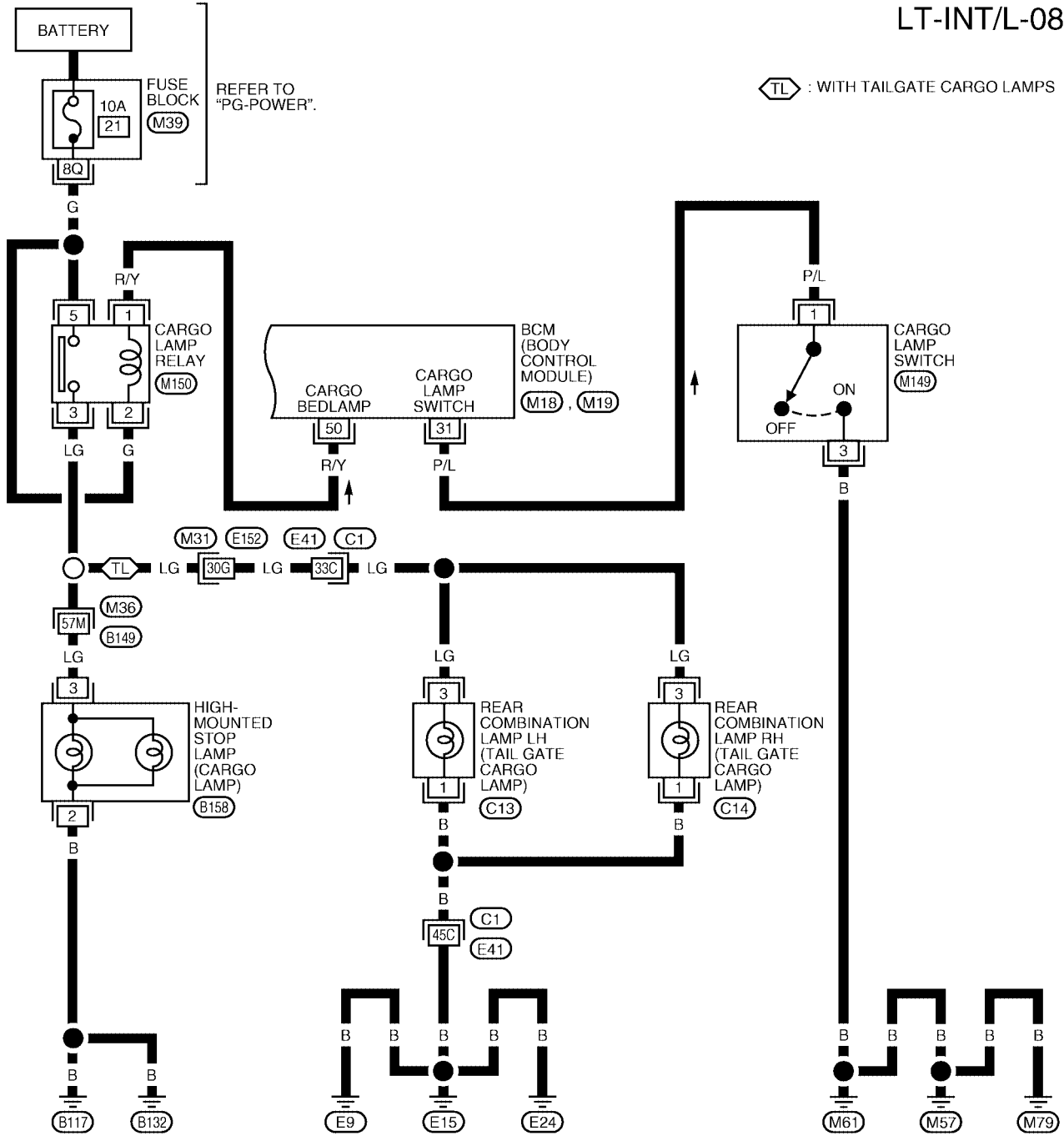

REFER TO THE FOLLOWING.
(M31), (M36), (C1) - SUPER
MULTIPLE JUNCTION (SMJ)

WKWA1564E

INTERIOR ROOM LAMP

Terminals and Reference Value for BCM

EKS0076G

Terminal No.	Wire color	Signal name	Measuring condition			Reference value (Approx.)	
			Ignition switch	Operation or condition			
12 (crew cab)	R/L	Front door switch RH signal	OFF	Front door switch RH	ON (open)	0V	
					OFF (closed)	Battery voltage	
12 (king cab)	R/L	Door switch RH signal	OFF	Door switch RH	ON (open)	0V	
					OFF (closed)	Battery voltage	
13 (crew cab)	GR	Rear door switch RH signal	OFF	Rear door switch RH	ON (open)	0V	
					OFF (closed)	Battery voltage	
22	G	Power window switch serial link	—	—	 <p style="text-align: right; font-size: small;">PIIA2344J</p>		
31	P/L	Cargo lamp switch signal	OFF	Cargo lamp switch ON.		0V	
				Cargo lamp switch OFF.		Battery voltage	
37	B/R	Key-in detection switch signal	OFF	Vehicle key is removed.		0V	
				Vehicle key is inserted.		Battery voltage	
38	W/L	Ignition power supply	ON	—	Battery voltage		
39	W	CAN-H	—	—	—		
40	R	CAN-L	—	—	—		
47 (crew cab)	SB	Front door switch LH signal	OFF	Front door switch LH	ON (open)	0V	
					OFF (closed)	Battery voltage	
47 (king cab)	SB	Door switch LH signal	OFF	Door switch LH	ON (open)	0V	
					OFF (closed)	Battery voltage	
48 (crew cab)	R/Y	Rear door switch LH signal	OFF	Rear door switch LH	ON (open)	0V	
					OFF (closed)	Battery voltage	
50	R/Y	Cargo bed lamp control	OFF	Cargo lamp switch ON		0V	
				Cargo lamp switch OFF		Battery voltage	
56	R/G	Battery saver output signal	OFF	30 minutes after ignition switch is turned to OFF		0V	
			ON	—	Battery voltage		
57	Y/R	Battery power supply	OFF	—	Battery voltage		
62	R/W	Step lamp signal	OFF	Any door is open (ON)		0V	
				All doors are closed (OFF)		Battery voltage	
63	L	Interior room/map lamp signal	OFF	Each interior lamp switch in DOOR position	Any door switch	ON (open)	0V
						OFF (closed)	Battery voltage
67	B	Ground	ON	—	0V		
70	W/B	Battery power supply	OFF	—	Battery voltage		

A
B
C
D
E
F
G
H
I
J
K
L
M

LT

INTERIOR ROOM LAMP

EKS0076H

How to Proceed With Trouble Diagnosis

1. Confirm the symptom or customer complaint.
2. Understand operation description and function description. Refer to [LT-131, "System Description"](#).
3. Carry out the Preliminary Check. Refer to [LT-146, "Preliminary Check"](#).
4. Check symptom and repair or replace the cause of malfunction.
5. Does the interior room lamp operate normally? If YES: GO TO 6. If NO: GO TO 4.
6. INSPECTION END.

Preliminary Check

EKS0076I

INSPECTION FOR POWER SUPPLY AND GROUND CIRCUIT

1. CHECK FUSES OR FUSIBLE LINK

Check for blown BCM fuses or fusible link.

Unit	Power source	Fuse or fusible link No.
BCM	Battery	f
		22
	Ignition switch ON or START position	59

Refer to [LT-137, "Wiring Diagram — INT/L —"](#).

OK or NG

OK >> GO TO 2.

NG >> If fuse is blown, be sure to eliminate cause of malfunction before installing new fuse. Refer to [PG-4, "POWER SUPPLY ROUTING CIRCUIT"](#).

2. CHECK POWER SUPPLY CIRCUIT

1. Disconnect BCM connector.
2. Check voltage between BCM connector and ground.

Terminals		Ignition switch position	
(+)		(-)	
Connector	Terminal (Wire color)	OFF	ON
M20	57 (Y/R)	Battery voltage	Battery voltage
	70 (W/B)	Battery voltage	Battery voltage
M18	38 (W/L)	0V	Battery voltage

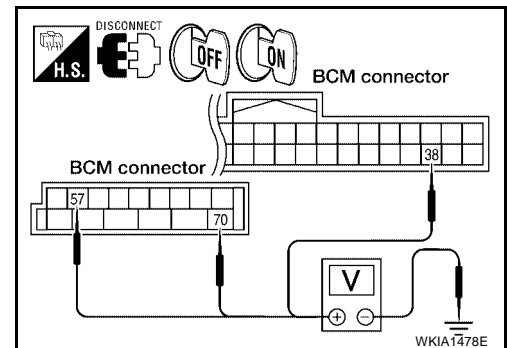

OK or NG

OK >> GO TO 3.

NG >> Check harness for open between BCM and fuse.

3. CHECK GROUND CIRCUIT

Check continuity between BCM and ground.

Terminals		(-)	Continuity
(+)			
Connector	Terminal (Wire color)		
M20	67 (B)	Ground	Yes

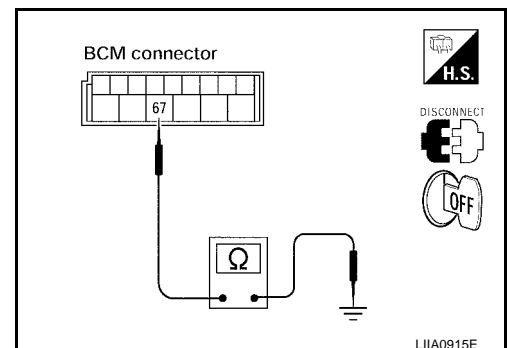

OK or NG

OK >> INSPECTION END

NG >> Check harness ground circuit.

INTERIOR ROOM LAMP

EKS0076J

CONSULT-II Functions

CONSULT-II can display each diagnostic item using the diagnostic test modes shown following.

BCM diagnosis part	Check item, diagnosis mode	Description
INT LAMP	Work support	Changes the setting for each function.
	Data monitor	Displays BCM input data in real time.
	CAN DIAG SUPPORT MNTR	The result of transmit/receive diagnosis of CAN communication can be read.
	Active test	Operation of electrical loads can be checked by sending driving signal to them.

CONSULT-II BASIC OPERATION

CAUTION:

If CONSULT-II is used with no connection of CONSULT-II CONVERTER, malfunctions might be detected in self-diagnosis depending on control unit which carries out CAN communication.

1. With the ignition switch OFF, connect CONSULT-II and CONSULT-II CONVERTER to the data link connector, then turn ignition switch ON.

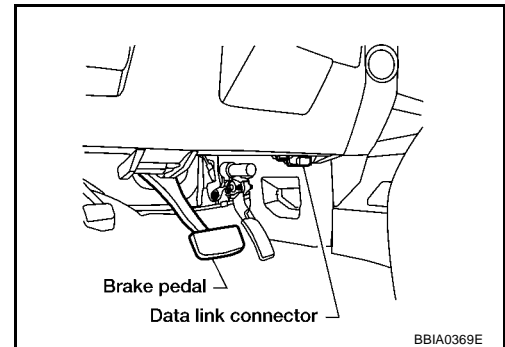

2. Touch "START (NISSAN BASED VHCL)".

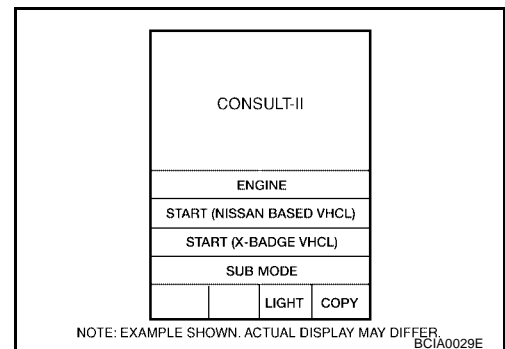

3. Touch "BCM" on "SELECT SYSTEM" screen. If "BCM" is not indicated, go to [GI-38, "CONSULT-II Data Link Connector \(DLC\) Circuit"](#).

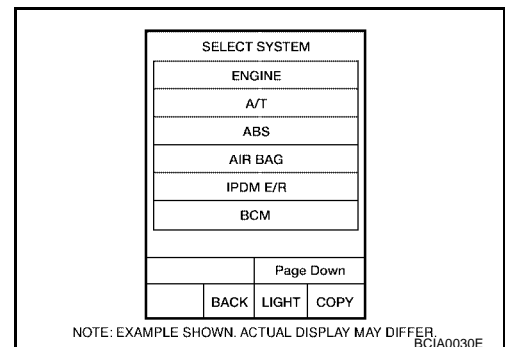

INTERIOR ROOM LAMP

4. Touch "INT LAMP" on "SELECT SYSTEM" screen.

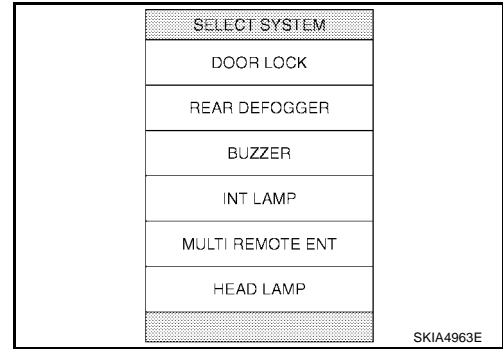

WORK SUPPORT

Operation Procedure

1. Touch "INT LAMP" on "SELECT SYSTEM" screen.
2. Touch "WORK SUPPORT" on "SELECT DIAG MODE" screen.
3. Touch "SET I/L D- UNLCK INTCON" on "SELECT WORK ITEM" screen.
4. Touch "START".
5. Touch "CHANGE SETT".
6. The setting will be changed and "CUSTOMIZING COMPLETED " will be displayed.
7. Touch "END".

Display Item List

Item	Description	CONSULT-II
SET I/L D-UNLCK INTCON	The 30 seconds operating function of the interior room lamps can be selected when driver door is released (unlocked).	ON/OFF
ROOM LAMP ON TIME SET	The time in order to escalate illumination can be adjusted when the interior room lamps are turned on.	MODE 1 – 7
ROOM LAMP OFF TIME SET	The time in order to diminish illumination can be adjusted when the interior room lamps are turned off.	MODE 1 – 7

Reference between "MODE" and "TIME" for "TURN ON/OFF"

MODE	1	2	3	4	5	6	7
Time (sec.)	0.5	1	2	3	4	5	0

DATA MONITOR

Operation Procedure

1. Touch "INT LAMP" on "SELECT TEST ITEM" screen.
2. Touch "DATA MONITOR" on "SELECT DIAG MODE" screen.
3. Touch either "ALL SIGNALS" or "SELECTION FROM MENU" on "DATA MONITOR" screen.

All signals	Monitors all the signals.
Selection from menu	Selects and monitors the individual signal.

4. Touch "START".
5. When "SELECTION FROM MENU" is selected, touch items to be monitored. When "ALL SIGNALS" is selected, all the items will be monitored.
6. Touch "RECORD" while monitoring, then the status of the monitored item can be recorded. To stop recording, touch "STOP".

INTERIOR ROOM LAMP

Display Item List

Monitor item	Contents
IGN ON SW "ON/OFF"	Displays "IGN position (ON)/OFF, ACC position (OFF)" judged from the ignition switch signal.
KEY ON SW "ON/OFF"	Displays "Key inserted (ON)/key removed (OFF)" status judged from the key switch signal.
DOOR SW - DR "ON/OFF"	Displays status of the driver door as judged from the driver door switch signal. (Door is open: ON/Door is closed: OFF)
DOOR SW - AS "ON/OFF"	Displays "Door open (ON)/Door closed (OFF)" status, determined from passenger door switch signal.
DOOR SW - RR "ON/OFF"	Displays "Door open (ON)/Door closed (OFF)" status, determined from rear door switch RH signal.
DOOR SW - RL "ON/OFF"	Displays "Door open (ON)/Door closed (OFF)" status, determined from rear door switch LH signal.
BACK DOOR SW "ON/OFF"	Displays "Door open (ON)/Door closed (OFF)" status, determined from back door switch signal.
KEY CYL LK - SW "ON/OFF"	Displays "Door locked (ON) status, determined from key cylinder lock switch in driver door.
KEY CYL UN - SW "ON/OFF"	Displays "Door unlocked (OFF) status, determined from key cylinder lock switch in driver door.
CDL LOCK SW "ON/OFF"	Displays "Door locked (ON)/Door unlocked (OFF) status, determined from locking detection switch in driver door.
CDL UNLOCK SW "ON/OFF"	Displays "Door unlocked (OFF)" status, determined from locking detection switch in passenger door.
KEYLESS LOCK "ON/OFF"	Displays "Locked (ON)/Other (OFF)" status, determined from lock signal.
KEYLESS UNLOCK "ON/OFF"	Displays "Unlocked (ON)/Other (OFF)" status, determined from unlock signal.

ACTIVE TEST

Operation Procedure

1. Touch "INT LAMP" on "SELECT TEST ITEM" screen.
2. Touch "ACTIVE TEST" on "SELECT DIAG MODE" screen.
3. Touch item to be tested and check operation of the selected item.
4. During the operation check, touching "BACK" or "OFF" deactivates the operation.

Display Item List

Test item	Description
INT LAMP	Interior room lamp can be operated by any ON-OFF operations.
IGN ILLUM ^{NOTE}	Ignition keyhole illumination can be operated by ON-OFF operation.

NOTE: This item is displayed but this model is not equipped.

Front Room/Map Lamp Assembly Control Does Not Operate

EKS0076K

1. CHECK EACH SWITCH

Select "BCM" on CONSULT-II. With "INT LAMP" data monitor, make sure switches listed in display item list turn ON-OFF linked with switch operation. Refer to [LT-149, "Display Item List"](#) for switches and their functions.

OK or NG

- OK >> GO TO 2.
 NG >> Inspect malfunctioning switch system.

DATA MONITOR	
MONITOR	
IGN ON SW	ON
KEY ON SW	ON
DOOR SW-DR	ON
DOOR SW-AS	ON
DOOR SW-RR	OFF
DOOR SW-RL	OFF
BACK DOOR SW	OFF
KEY CYL LK-SW	OFF
KEY CYL UN-SW	OFF

SKIA5930E

INTERIOR ROOM LAMP

2. ACTIVE TEST

1. Select "BCM" on CONSULT-II. Select "INT LAMP" active test.
2. When switch is in "DOOR" position, use active test to make sure interior room lamp operates.

Room lamps should turn on.

OK or NG

- OK >> Replace BCM. Refer to [BCS-25, "Removal and Installation of BCM"](#).
- NG >> GO TO 3.

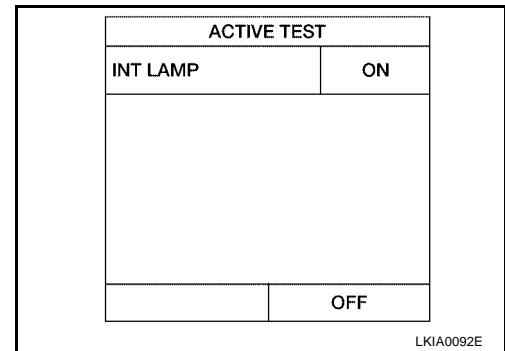

3. CHECK FRONT ROOM/MAP LAMP ASSEMBLY INPUT

1. Turn ignition switch OFF.
2. Check voltage between front room/map lamp assembly harness connector R102 terminal 6 (R/G) and ground.

Battery voltage should exist.

OK or NG

- OK >> GO TO 4.
- NG >> GO TO 5.

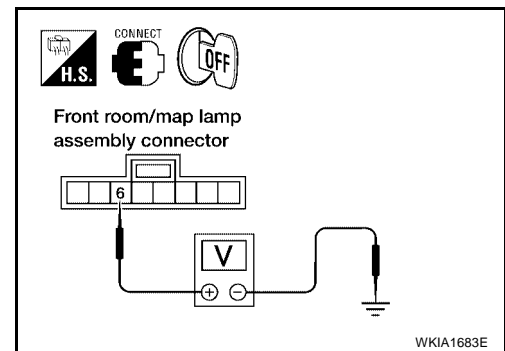

4. CHECK FRONT ROOM/MAP LAMP ASSEMBLY CIRCUIT

1. Disconnect BCM connector.
2. Check continuity between BCM harness connector M20 terminal 63 (L) and front room/map lamp assembly harness connector R102 terminal 1 (L).

Continuity should exist.

OK or NG

- OK >> Replace front room/map lamp assembly.
- NG >> Repair harness or connector.

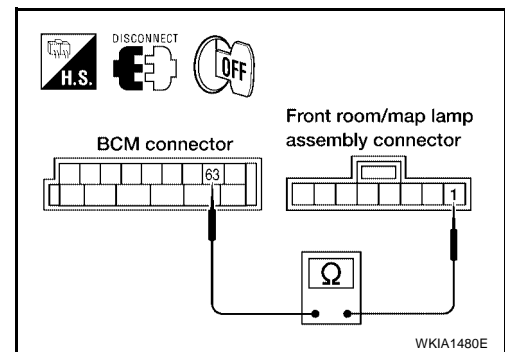

5. CHECK FRONT ROOM/MAP LAMP ASSEMBLY CIRCUIT

1. Disconnect BCM connector and interior room lamp connector.
2. Check continuity between BCM harness connector M20 terminal 56 (R/G) and front room/map lamp assembly harness connector R102 terminal 6 (R/G).

Continuity should exist.

OK or NG

- OK >> Replace BCM if interior lamp does not work after setting the connector again. Refer to [BCS-25, "Removal and Installation of BCM"](#).
- NG >> Repair harness or connector between BCM and room/map lamp.

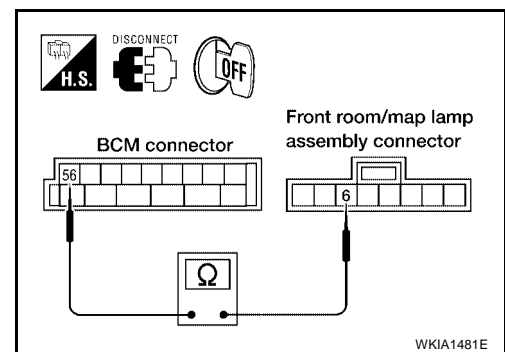

INTERIOR ROOM LAMP

Personal Lamp 2nd Row Control Does Not Operate (Room/Map Lamps Operate)

EKS0076L

1. CHECK EACH DOOR SWITCH

Select "BCM" on CONSULT-II. With "INT LAMP" data monitor, make sure switches listed in display item list turn ON-OFF linked with switch operation. Refer to [LT-132, "SWITCH OPERATION"](#) for switches and their function.

OK or NG

- OK >> GO TO 2.
- NG >> Inspect malfunctioning door switch.

DATA MONITOR	
MONITOR	
IGN ON SW	ON
KEY ON SW	ON
DOOR SW-DR	ON
DOOR SW-AS	ON
DOOR SW-RR	OFF
DOOR SW-RL	OFF
BACK DOOR SW	OFF
KEY CYL LK-SW	OFF
KEY CYL UN-SW	OFF

SKIA5930E

2. CHECK PERSONAL LAMP 2ND ROW OUTPUT

1. Turn ignition switch OFF.
2. Confirm lamp switch is in the "DOOR" position.
3. Disconnect personal lamp 2nd row connector.
4. Open any door.
5. Check voltage between personal lamp 2nd row harness connector terminal 3 (R/G) and ground.

Battery voltage should exist.

OK or NG

- OK >> GO TO 3.
- NG >> Repair harness or connector.

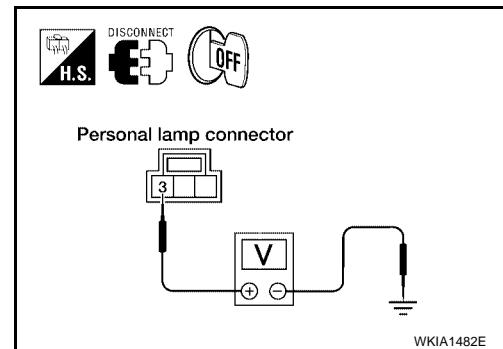

3. CHECK PERSONAL LAMP 2ND ROW CONTROL CIRCUIT

1. Disconnect front room/map lamp assembly connector.
2. Check continuity between front room/map lamp assembly harness connector R102 terminal 2 (R) and personal lamp 2nd row harness connector terminal 1 (R).

Continuity should exist.

OK or NG

- OK >> Replace personal lamp 2nd row.
- NG >> Repair harness or connector.

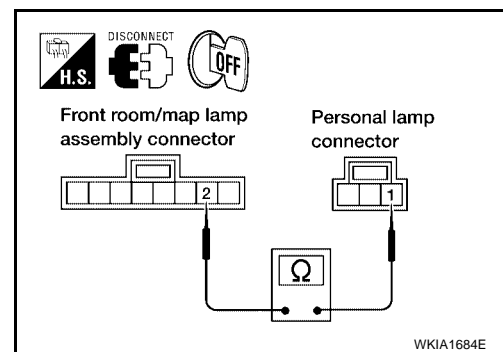

INTERIOR ROOM LAMP

EKS0076M

All Step/Foot/Puddle Lamps Do Not Operate

1. CHECK EACH DOOR SWITCH

Select "BCM" on CONSULT-II. With "INT LAMP" data monitor, make sure switches listed in display item list turn ON-OFF linked with switch operation. Refer to [LT-149, "Display Item List"](#) for switches and their functions.

OK or NG

- OK >> GO TO 2.
- NG >> Inspect malfunctioning switch system.

DATA MONITOR	
MONITOR	
IGN ON SW	ON
KEY ON SW	ON
DOOR SW-DR	ON
DOOR SW-AS	ON
DOOR SW-RR	OFF
DOOR SW-RL	OFF
BACK DOOR SW	OFF
KEY CYL LK-SW	OFF
KEY CYL UN-SW	OFF

SKIA5930E

2. CHECK STEP LAMP POWER SUPPLY

1. Turn ignition switch OFF.
2. Check voltage between front step lamp LH harness connector D11 terminal + (R/G) and ground.

Battery voltage should exist.

OK or NG

- OK >> GO TO 3.
- NG >> GO TO 4.

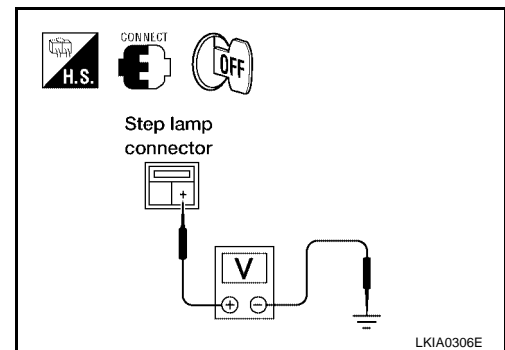

3. CHECK STEP LAMP CONTROL CIRCUIT

1. Disconnect BCM connector and front step lamp LH connector.
2. Check continuity between BCM harness connector M20 terminal 62 (R/W) and front step lamp LH harness connector D11 terminal - (R/W).

Continuity should exist.

OK or NG

- OK >> Replace BCM if step lamp does not work after setting the connector again. Refer to [BCS-25, "Removal and Installation of BCM"](#).
- NG >> Repair harness or connector.

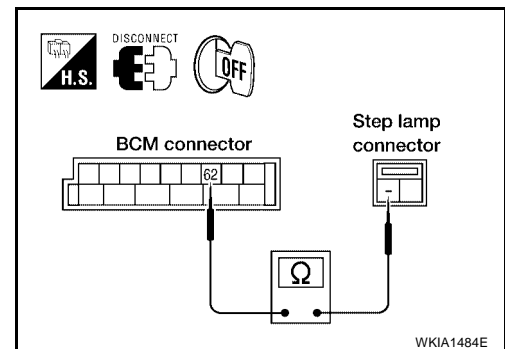

4. CHECK STEP LAMP CIRCUIT

1. Disconnect BCM connector and step lamp LH connector.
2. Check continuity between BCM harness connector M20 terminal 56 (R/G) and front step lamp LH harness connector D11 terminal + (R/G).

Continuity should exist.

OK or NG

- OK >> Replace BCM if step lamp does not work after setting the connector again. Refer to [BCS-25, "Removal and Installation of BCM"](#).
- NG >> Repair harness or connector.

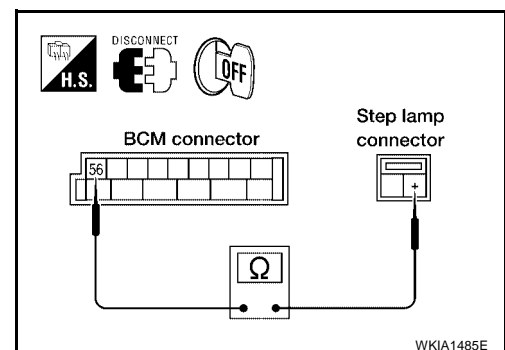

INTERIOR ROOM LAMP

All Interior Room Lamps Do Not Operate

EKS0076N

1. CHECK POWER SUPPLY CIRCUIT

1. All interior room lamp switches are OFF.
2. Turn ignition switch ON.
3. Check voltage between BCM harness connector M20 terminal 56 (R/G) and ground.

Battery voltage should exist.

OK or NG

- OK >> Repair harness or connector. In a case of making a short circuit, be sure to disconnect battery negative cable after repairing harness, and then reconnect.
- NG >> Replace BCM. Refer to [BCS-25, "Removal and Installation of BCM"](#).

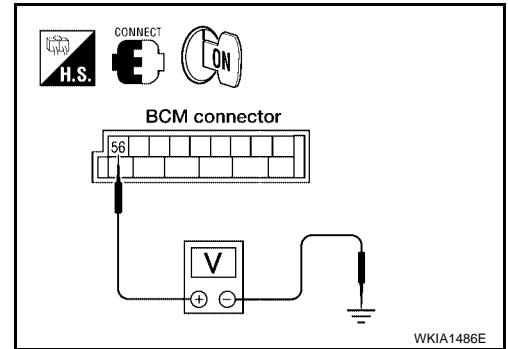

A
B
C
D
E
F
G
H
I
J
LT
L
M

ILLUMINATION

PFP:27545

ILLUMINATION

Component Parts and Harness Connector Location

EKS00760

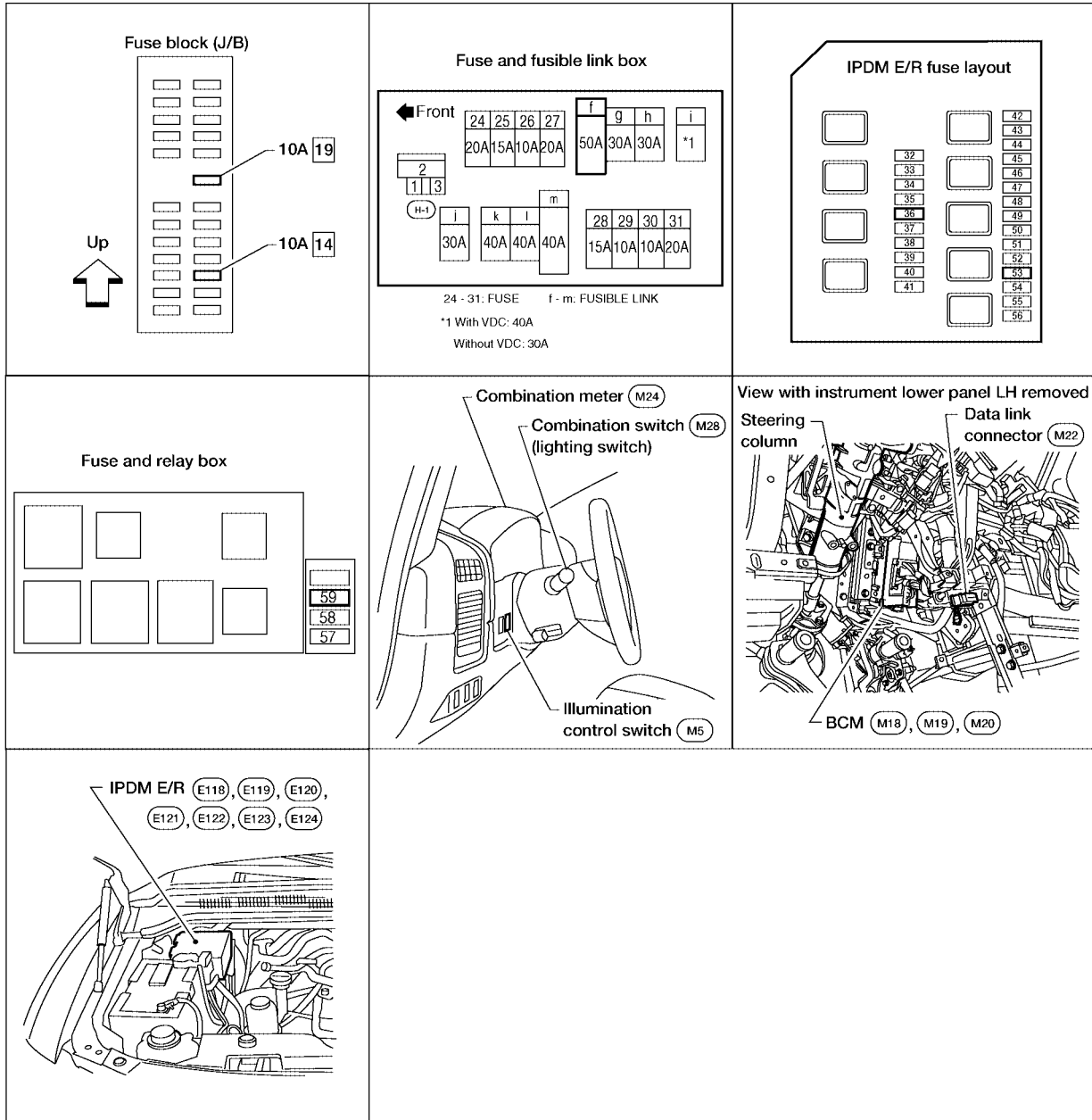

WKIA2836E

ILLUMINATION

EKS0076P

System Description

Control of the illumination lamps operation is dependent upon the position of the lighting switch (combination switch). When the lighting switch is placed in the 1ST or 2ND position (or if the auto light system is activated) the BCM (body control module) receives input signal requesting the illumination lamps to illuminate. This input signal is communicated to the IPDM E/R (intelligent power distribution module engine room) across the CAN communication lines. The central processing unit of the IPDM E/R controls the tail lamp relay coil. This relay, when energized, directs power to the illumination lamps, which then illuminate.

Power is supplied at all times to tail lamp relay, located in the IPDM E/R.

Power is also supplied at all times

- to BCM terminal 70
- through 50A fusible link (letter f , located in the fuse and fusible link box)
- to CPU (central processing unit) in the IPDM E/R
- through 20A fuse (No. 53 located in the IPDM E/R)
- to combination meter terminal 8
- through 10A fuse [No.19 located in fuse block (J/B)] and
- to ignition relay (located in the IPDM E/R) from battery.

With the ignition switch in the ON or START position, power is supplied

- to BCM terminal 38
- through 10A fuse (No. 59, located in the fuse and relay box)
- to ignition relay in the IPDM E/R
- to combination meter terminal 24
- through 10A fuse [No. 14 located in the fuse block (J/B)].

Ground is supplied

- to BCM terminal 67 and
- to combination meter terminal 17
- through grounds M57, M61, and M79
- to IPDM E/R terminals 38 and 59
- through grounds E9, E15 and E24.

ILLUMINATION OPERATION BY LIGHTING SWITCH

With the lighting switch in the 1ST or 2ND position (or if the auto light system is activated), the BCM receives input signal requesting the illumination lamps to illuminate. This input signal is communicated to the IPDM E/R across the CAN communication lines. The central processing unit of the IPDM E/R controls the tail lamp relay coil, which, when energized, directs power

- through 10A fuse (No. 36, located in the IPDM E/R)
- to IPDM E/R terminal 49
- to illumination control switch terminal 1
- to glove box lamp terminal + (with glove box lamp)
- to A/T device terminal 11
- to cargo lamp switch terminal 4
- to VDC OFF switch terminal 3 (with VDC)
- to hazard switch terminal 7
- to AV switch terminal 3
- to audio unit terminal 8
- to rear sonar system OFF switch terminal 3 (with rear sonar system)
- to front room/map lamp assembly (console box illumination) terminal 7
- to display control unit terminal 14 (with NAVI)
- to A/C control unit terminal 23
- to NAVI control unit terminal 25 (with NAVI)
- to DVD player terminal 12 (with DVD entertainment system)
- to 4WD shift switch terminal 7 (with 4-wheel drive)

A
B
C
D
E
F
G
H
I
J

LT

L

M

ILLUMINATION

- to pedal adjusting switch terminal 5
- to electric brake terminal 4
- to tow mode switch terminal 3
- to heated seat switches terminal 5 (with heated seats).

Illumination is controlled

- through illumination control switch terminal 2
- to A/T device terminal 12
- to VDC OFF switch terminal 4 (with VDC)
- to audio unit terminal 7
- to hazard switch terminal 8
- to AV switch terminal 4
- to rear sonar system OFF switch terminal 4 (with rear sonar system)
- to front room/map lamp assembly (console box illumination) terminal 8
- to A/C control unit terminal 24
- to DVD player terminal 10 (with DVD entertainment system)
- to cargo lamp switch terminal 2
- to 4WD switch terminal 8 (with 4-wheel drive)
- to pedal adjusting switch terminal 6
- to heated seat switches terminal 6 (with heated seats)
- to combination meter terminal 18
- to tow mode switch terminal 4.

Ground is supplied at all times

- to illumination control switch terminal 3
- to glove box lamp terminal -
- to display control unit terminal 3 (with NAVI)
- to electric brake terminal 1
- through grounds M57, M61 and M79
- to NAVI control unit terminal 30 (with NAVI)
- through grounds B117 and B132.

With power and ground supplied, illumination lamps illuminate.

EXTERIOR LAMP BATTERY SAVER CONTROL

When the combination switch (lighting switch) is in the 1ST or 2ND position (or if auto light system is activated), and the ignition switch is turned from ON or ACC to OFF, the battery saver control function is activated. Under this condition, the illumination lamps remain illuminated for 5 minutes, then the illumination lamps are turned off.

When the lighting switch is turned from OFF to 1ST or 2ND position (or if auto light system is activated) after illumination lamps are turned off by the battery saver control, the illumination lamps illuminate again. Exterior lamp battery saver control mode can be changed by the function setting of CONSULT-II.

CAN Communication System Description

EKS0076Q

Refer to [LAN-8, "CAN COMMUNICATION"](#) .

ILLUMINATION

Schematic

EKS0076R

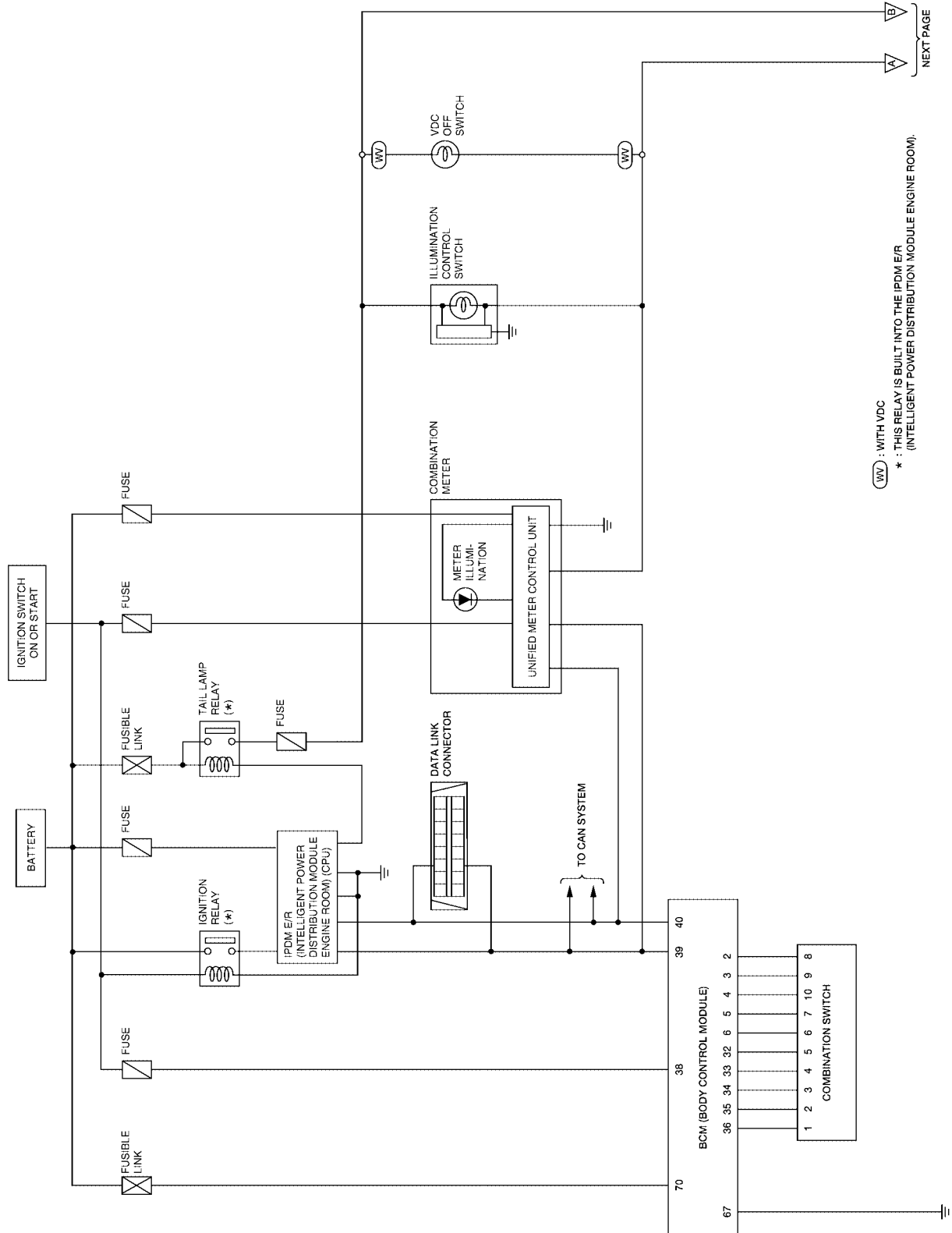

(WV) : WITH VDC
 * : THIS RELAY IS BUILT INTO THE IPDM E/R
 (INTELLIGENT POWER DISTRIBUTION MODULE ENGINE ROOM).

△ A }
 △ B }
 NEXT PAGE

A
 B
 C
 D
 E
 F
 G
 H
 I
 J
 LT
 L
 M

WKWA1085E

ILLUMINATION

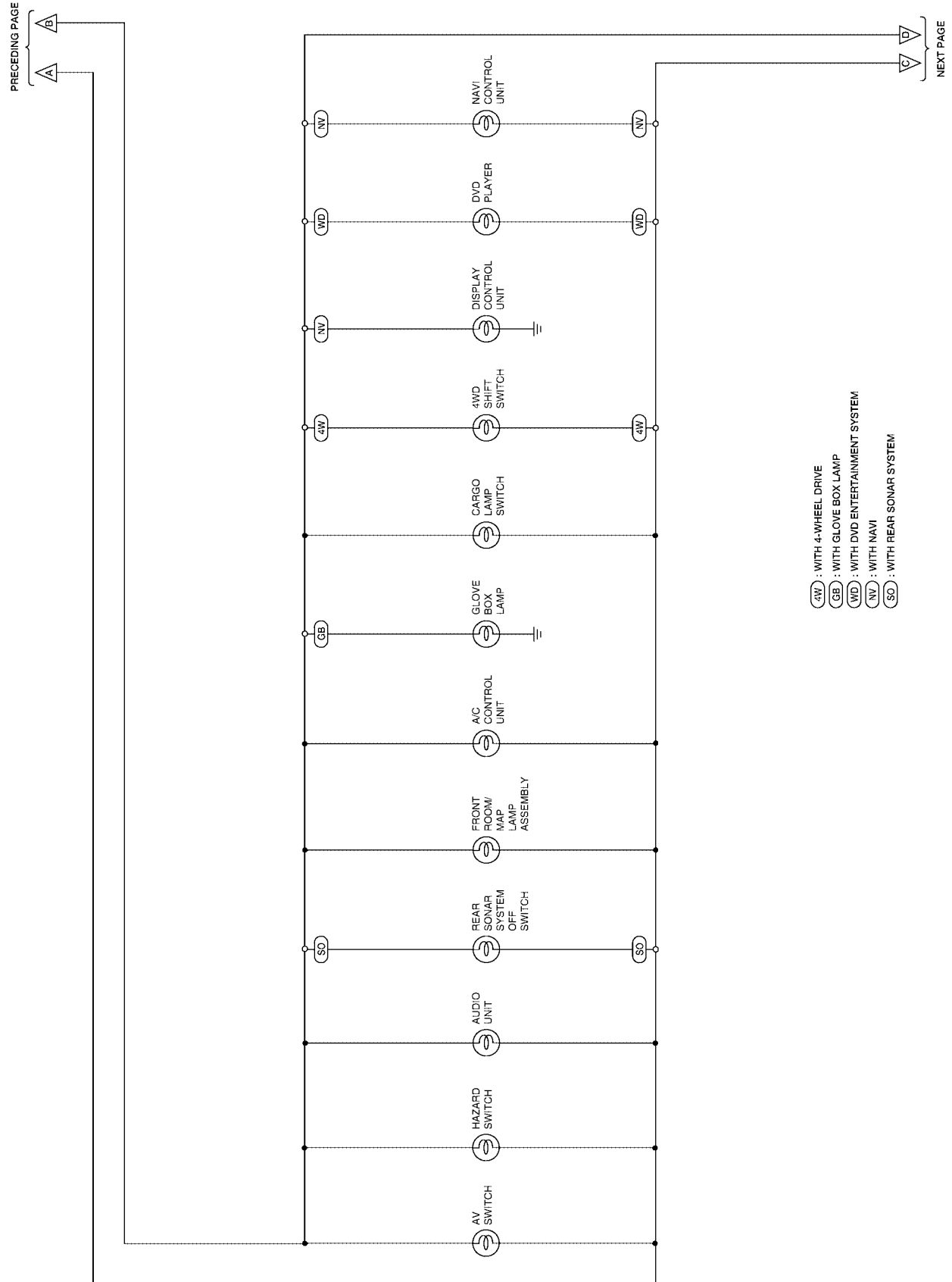

WKWA1086E

ILLUMINATION

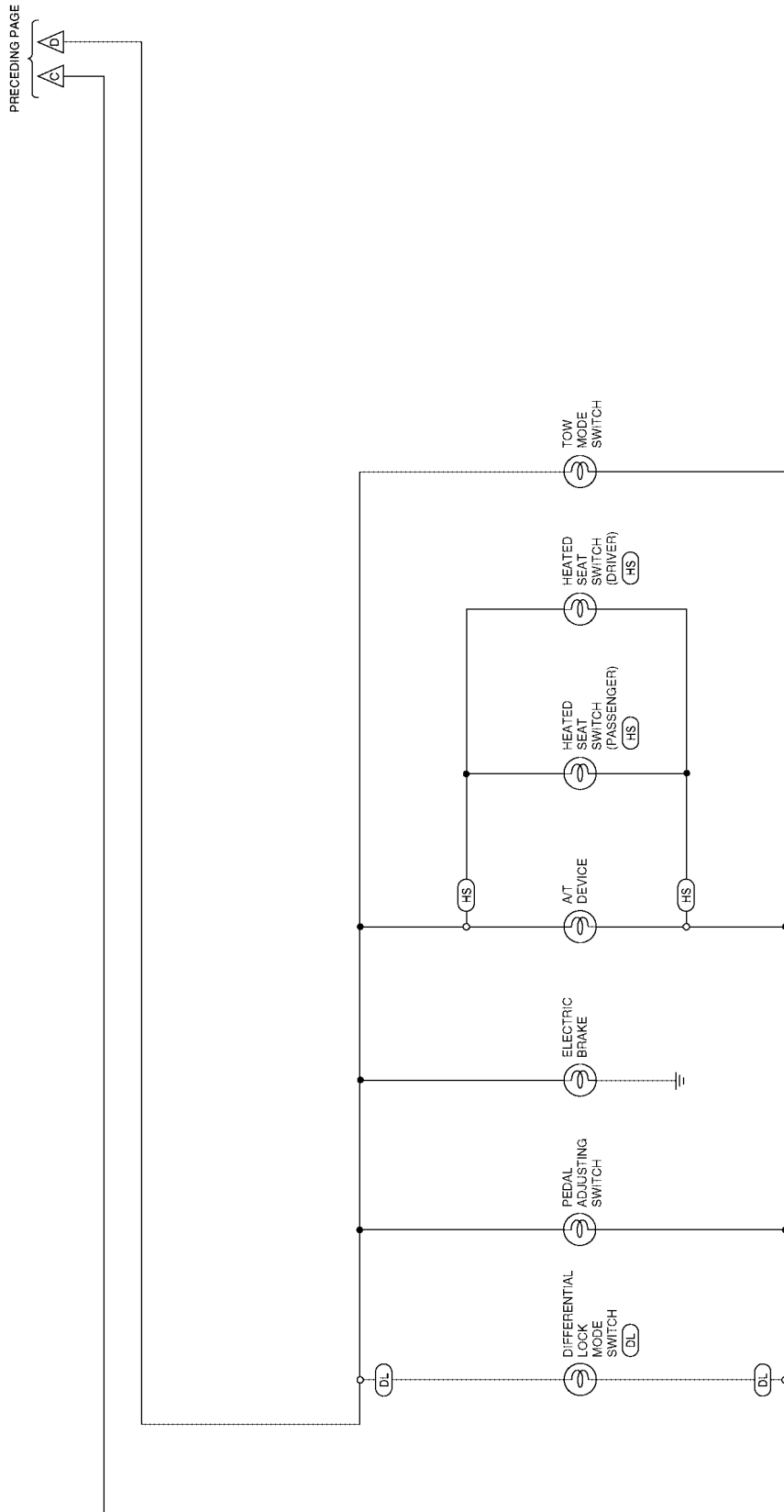

(HS) : WITH HEATED SEATS
 (DL) : WITH ELECTRONIC LOCKING REAR DIFFERENTIAL

A
 B
 C
 D
 E
 F
 G
 H
 I
 J
LT
 L
 M

ILLUMINATION

Wiring Diagram — ILL —

EKS0076S

LT-ILL-01

— — — : DATA LINE

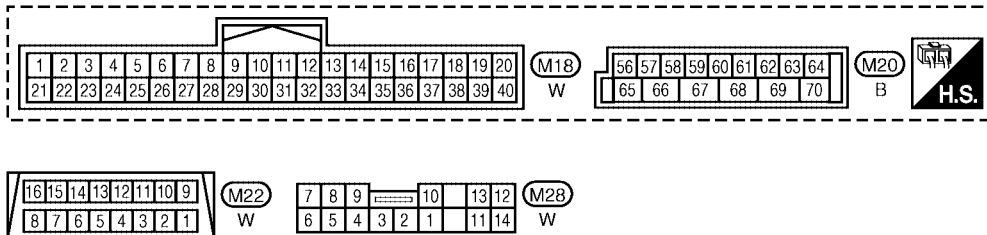
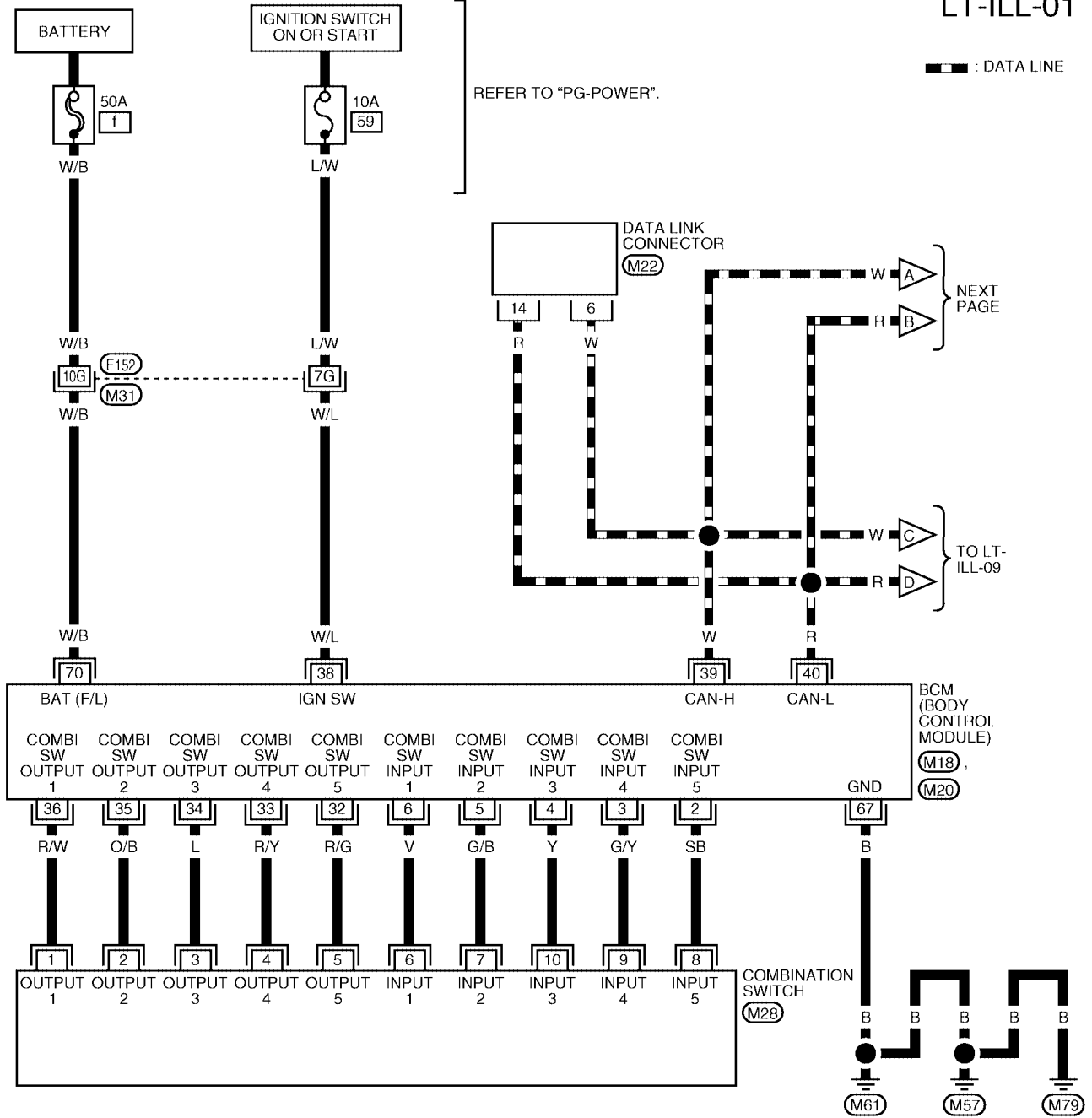

REFER TO THE FOLLOWING.
 (M31) - SUPER MULTIPLE JUNCTION (SMJ)

WKWA1164E

ILLUMINATION

LT-ILL-02

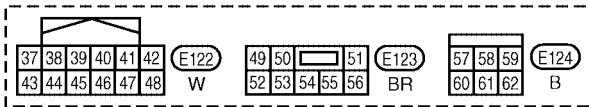
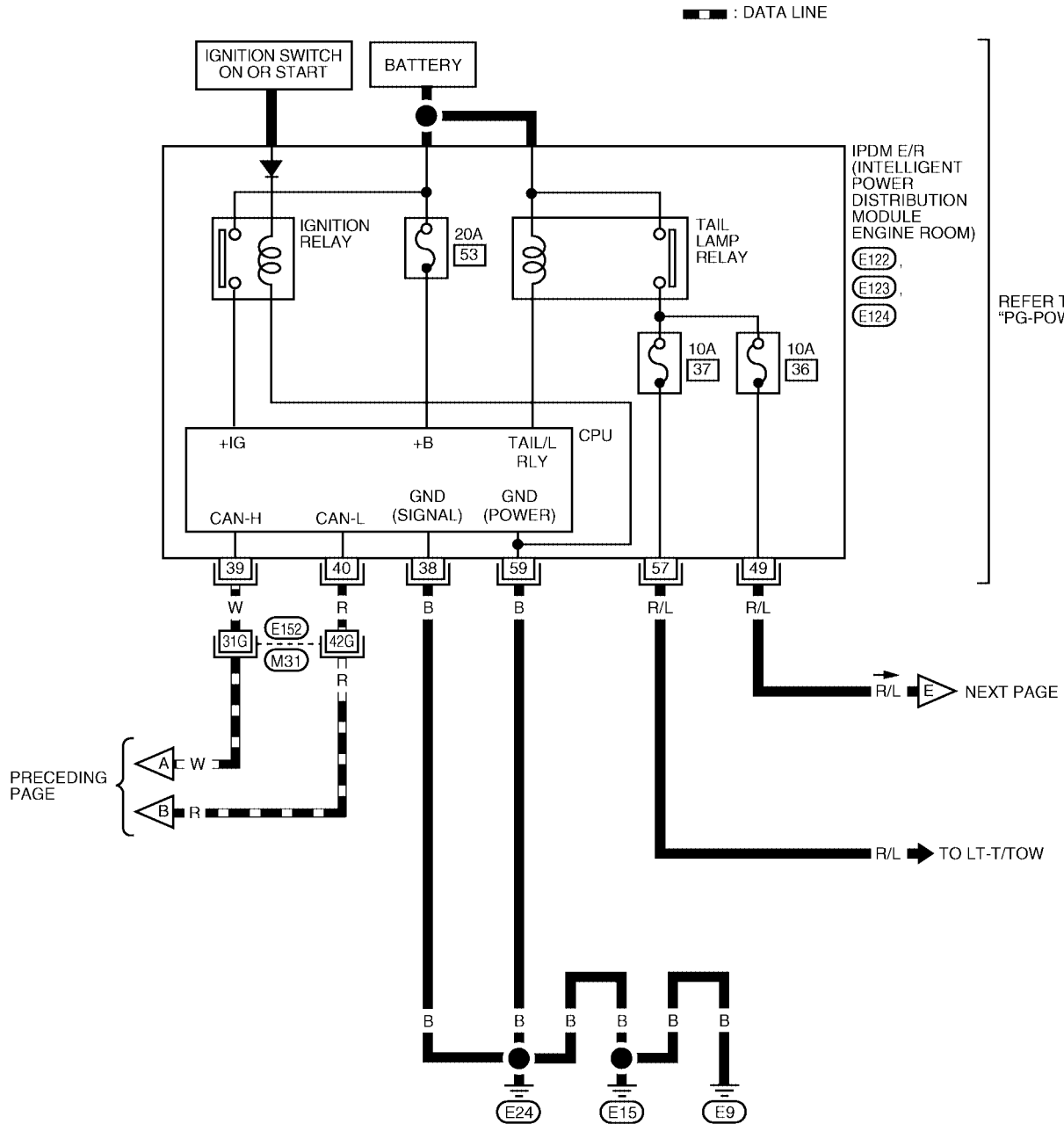

REFER TO THE FOLLOWING.
 (M31) - SUPER MULTIPLE JUNCTION (SMJ)

WKWA1514E

ILLUMINATION

LT-ILL-03

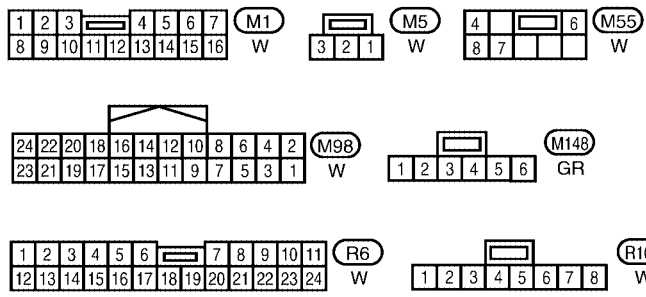
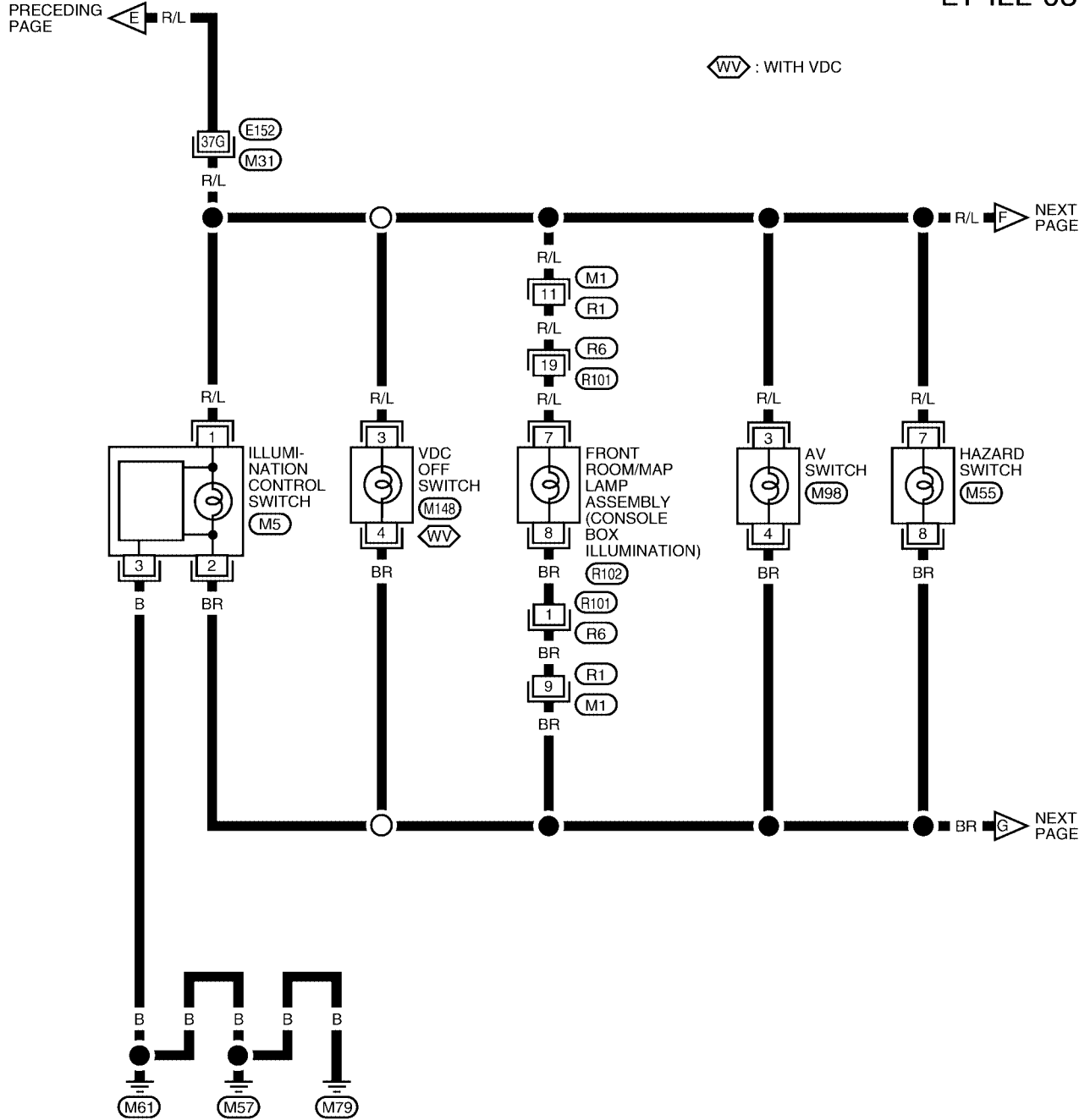

REFER TO THE FOLLOWING.
 (M31) - SUPER MULTIPLE JUNCTION (SMJ)

WKWA1089E

ILLUMINATION

LT-ILL-04

: WITH ELECTRONIC LOCKING REAR DIFFERENTIAL

: WITH GLOVE BOX LAMP

: WITH REAR SONAR SYSTEM

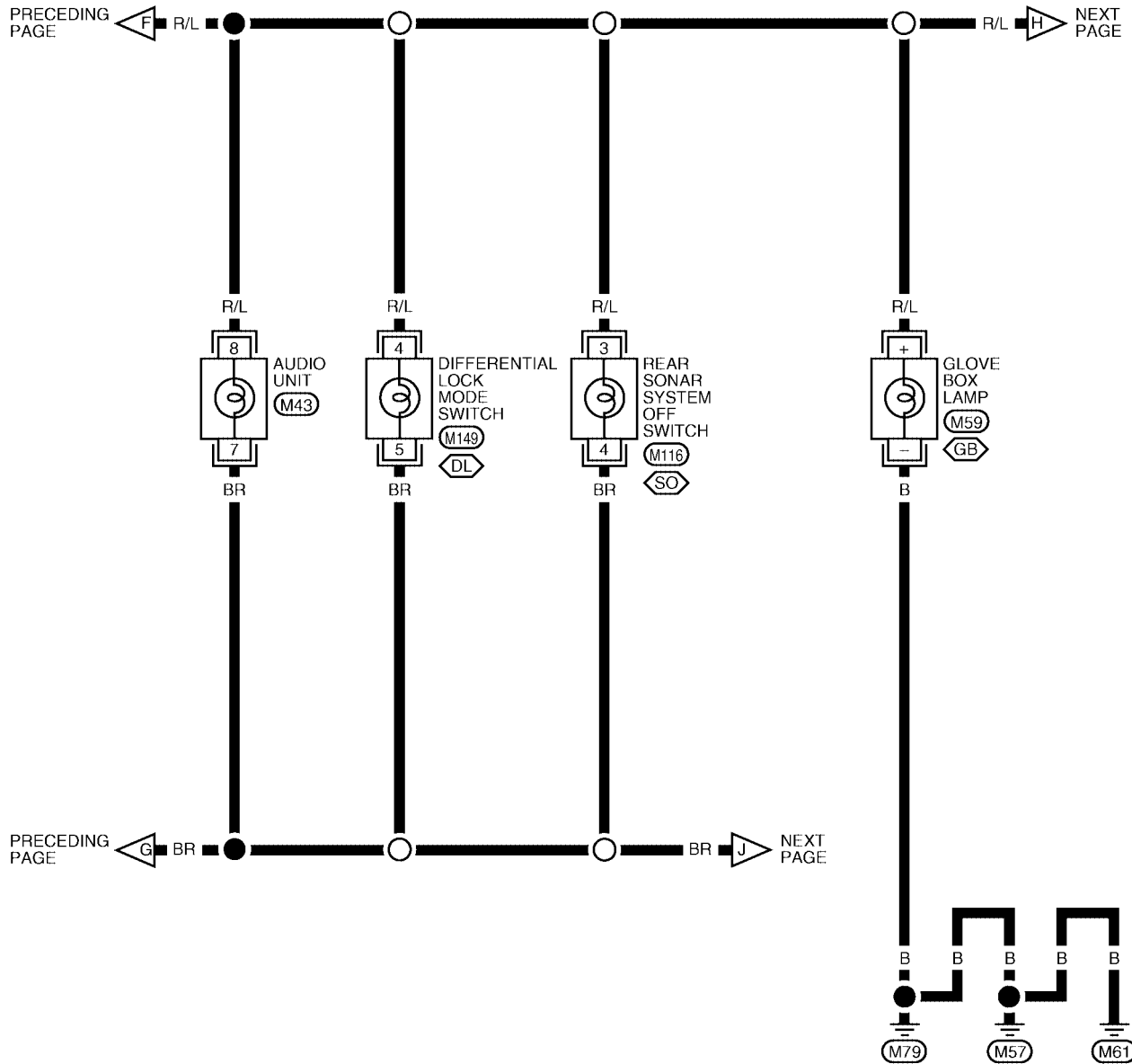

A
B
C
D
E
F
G
H
I
J
LT
L
M

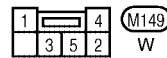
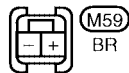
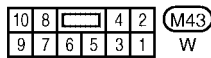

WKWA1506E

ILLUMINATION

LT-ILL-05

NV : WITH NAVI
4W : WITH 4-WHEEL DRIVE

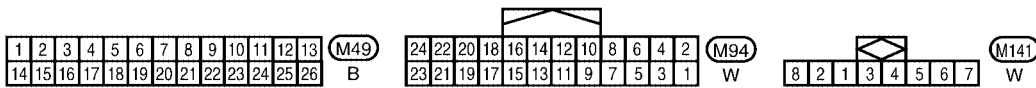
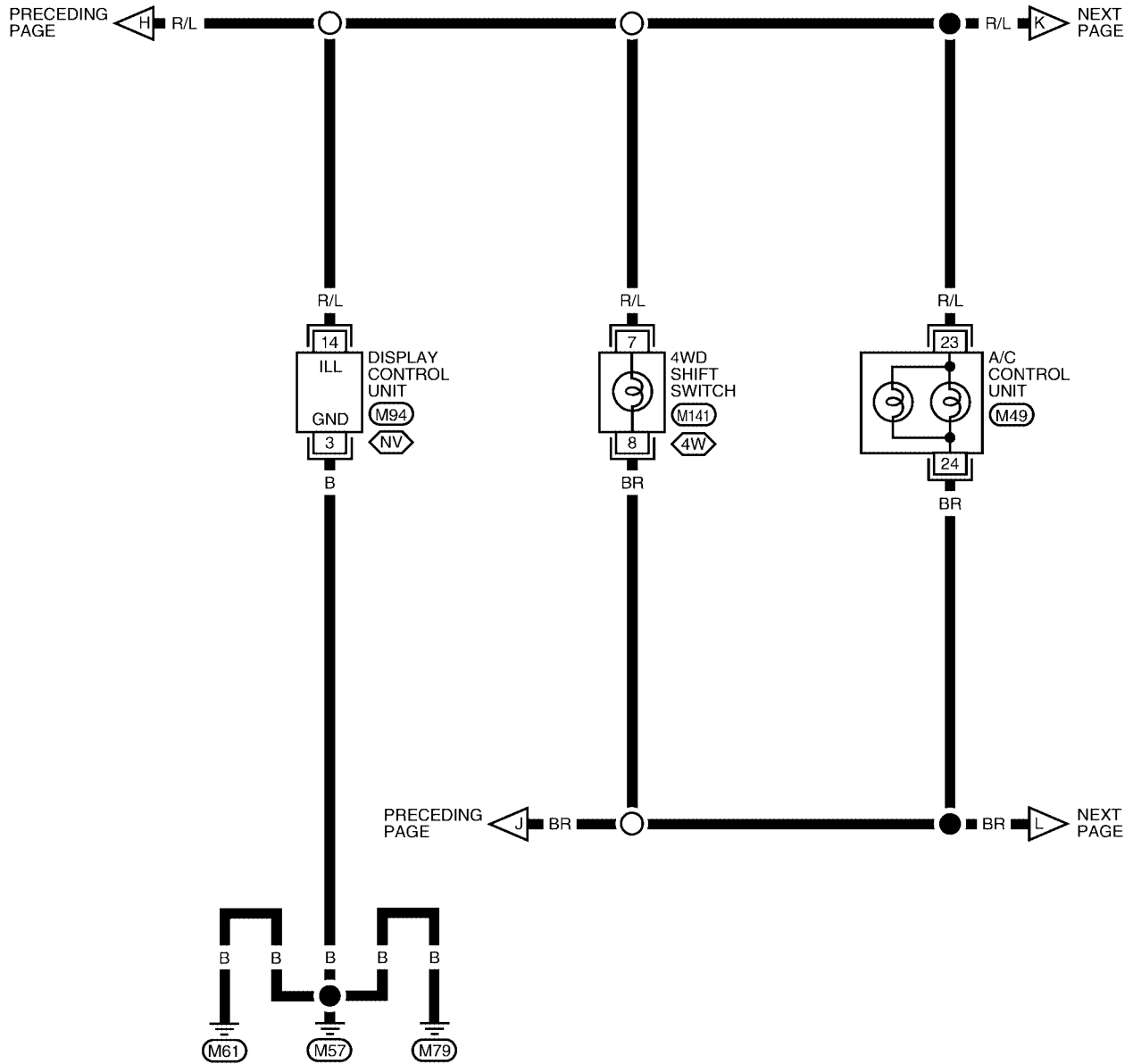

WKWA1091E

ILLUMINATION

LT-ILL-06

: WITH NAVI

: WITH DVD ENTERTAINMENT SYSTEM

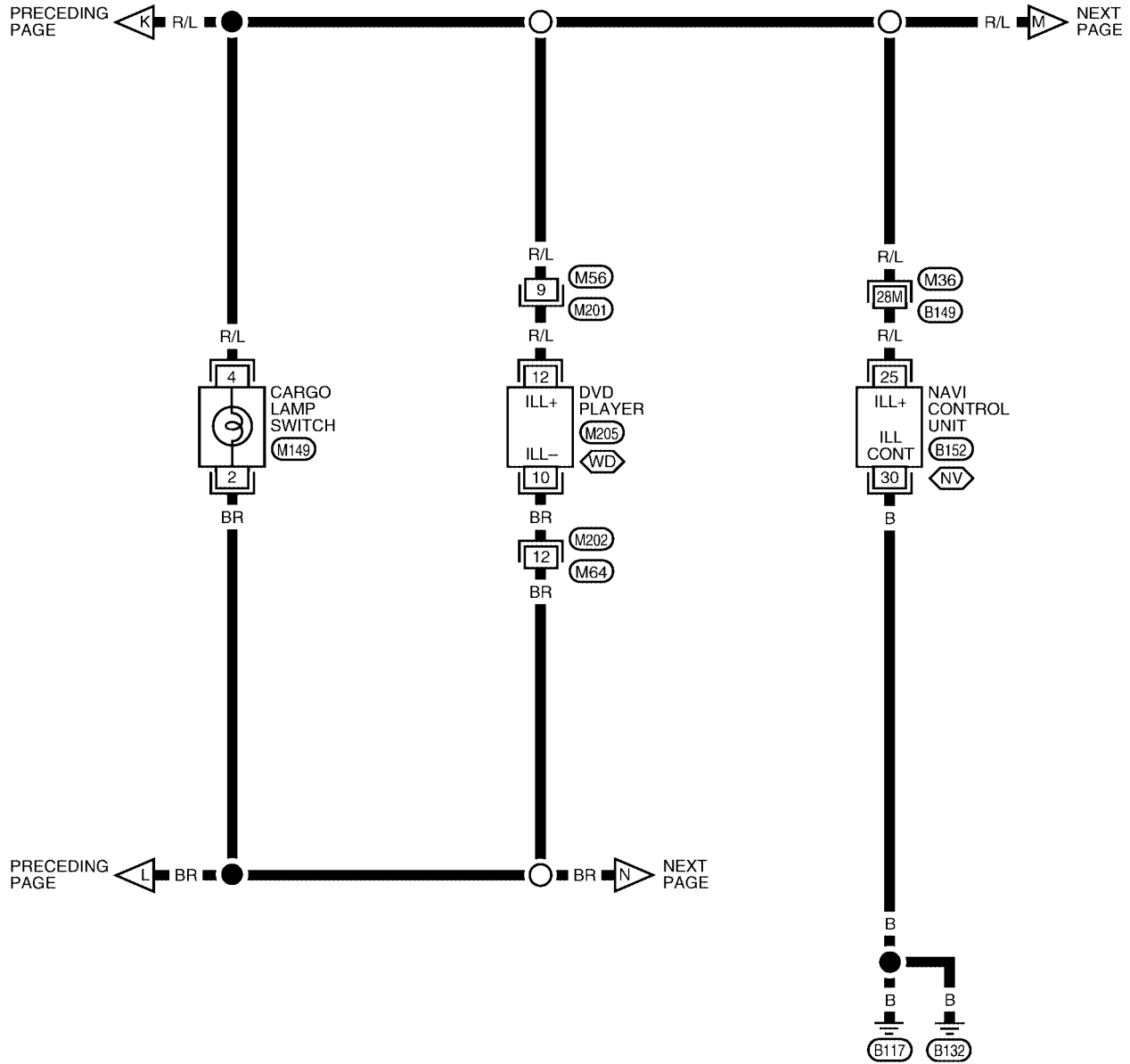

A
B
C
D
E
F
G
H
I
J
LT
L
M

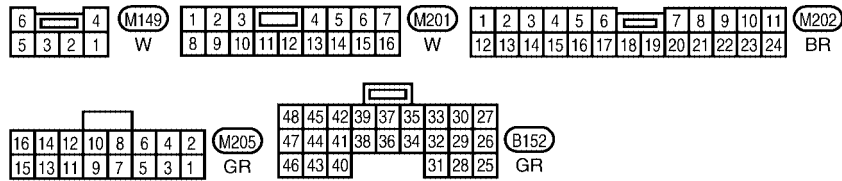

REFER TO THE FOLLOWING.
 - SUPER MULTIPLE JUNCTION (SMJ)

WKWA1092E

ILLUMINATION

LT-ILL-07

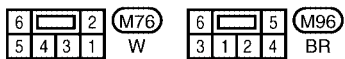
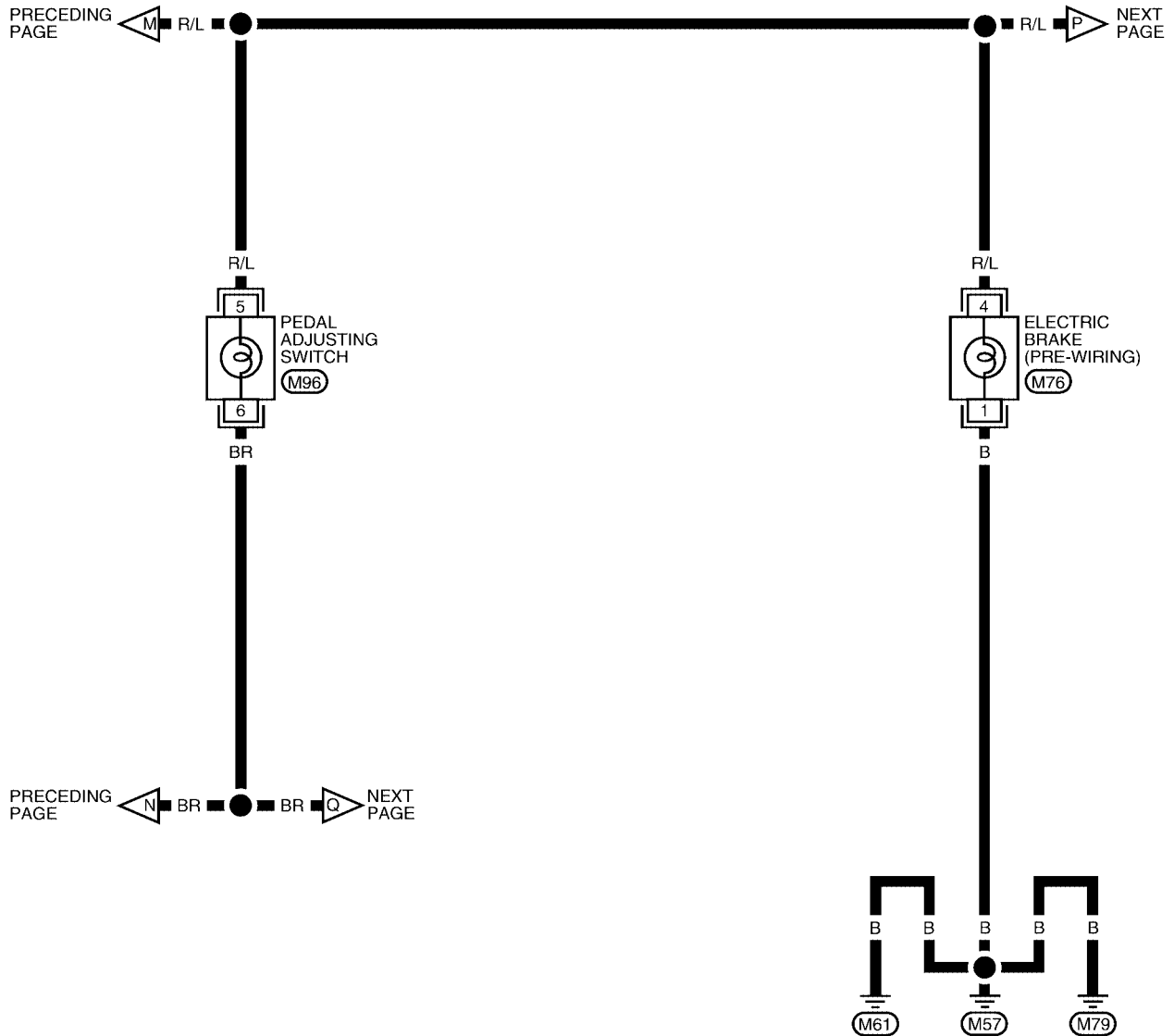

WKWA1093E

ILLUMINATION

LT-ILL-08

HS : WITH HEATED SEATS
 FS : FLOOR SHIFT

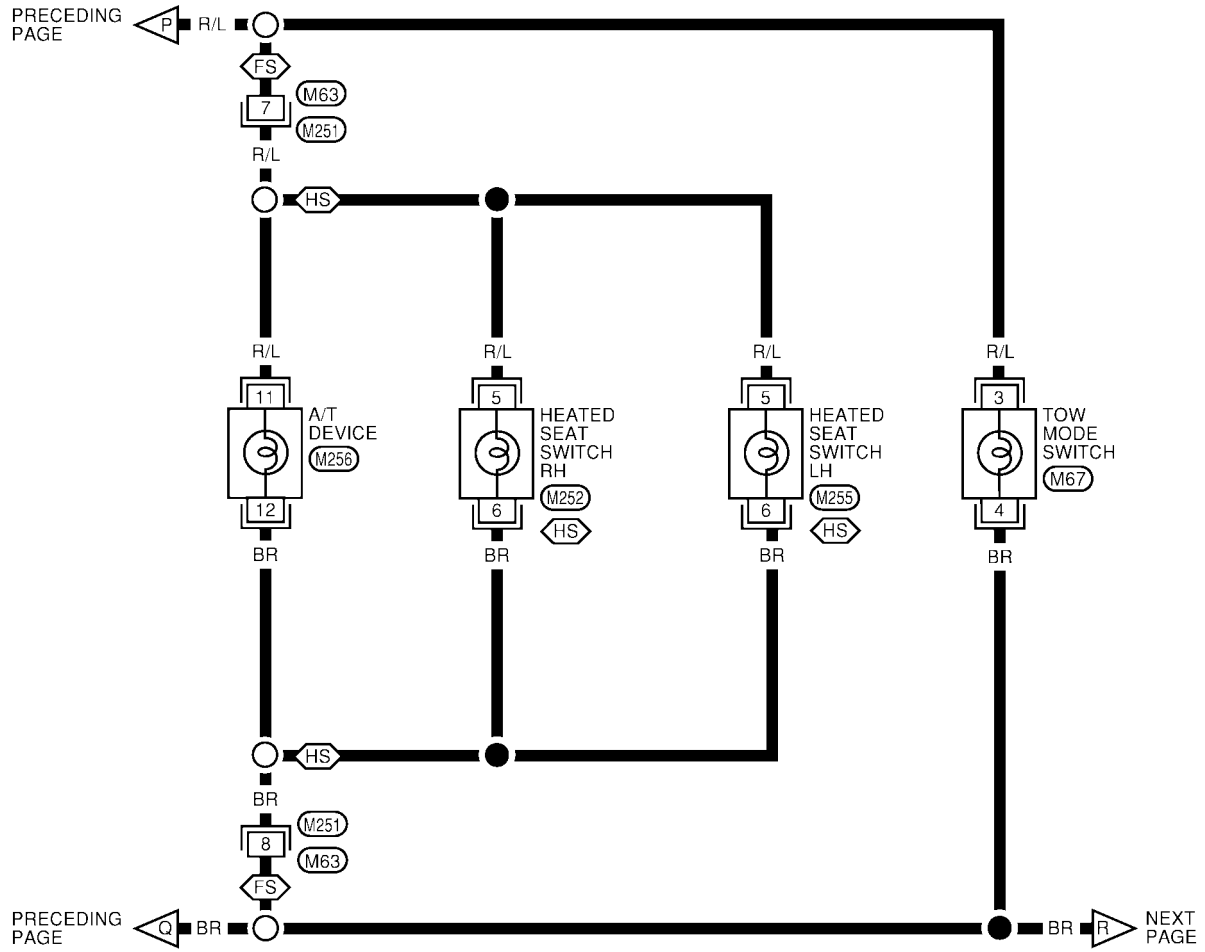

A
B
C
D
E
F
G
H
I
J
LT
L
M

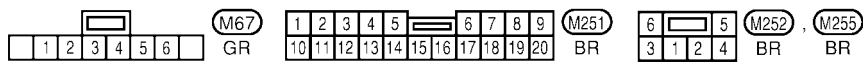

WKWA1565E

ILLUMINATION

LT-ILL-09

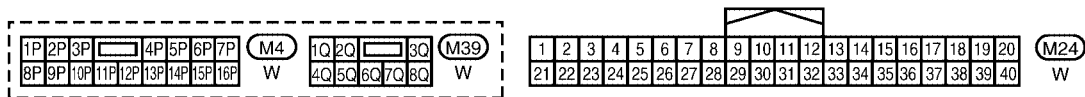
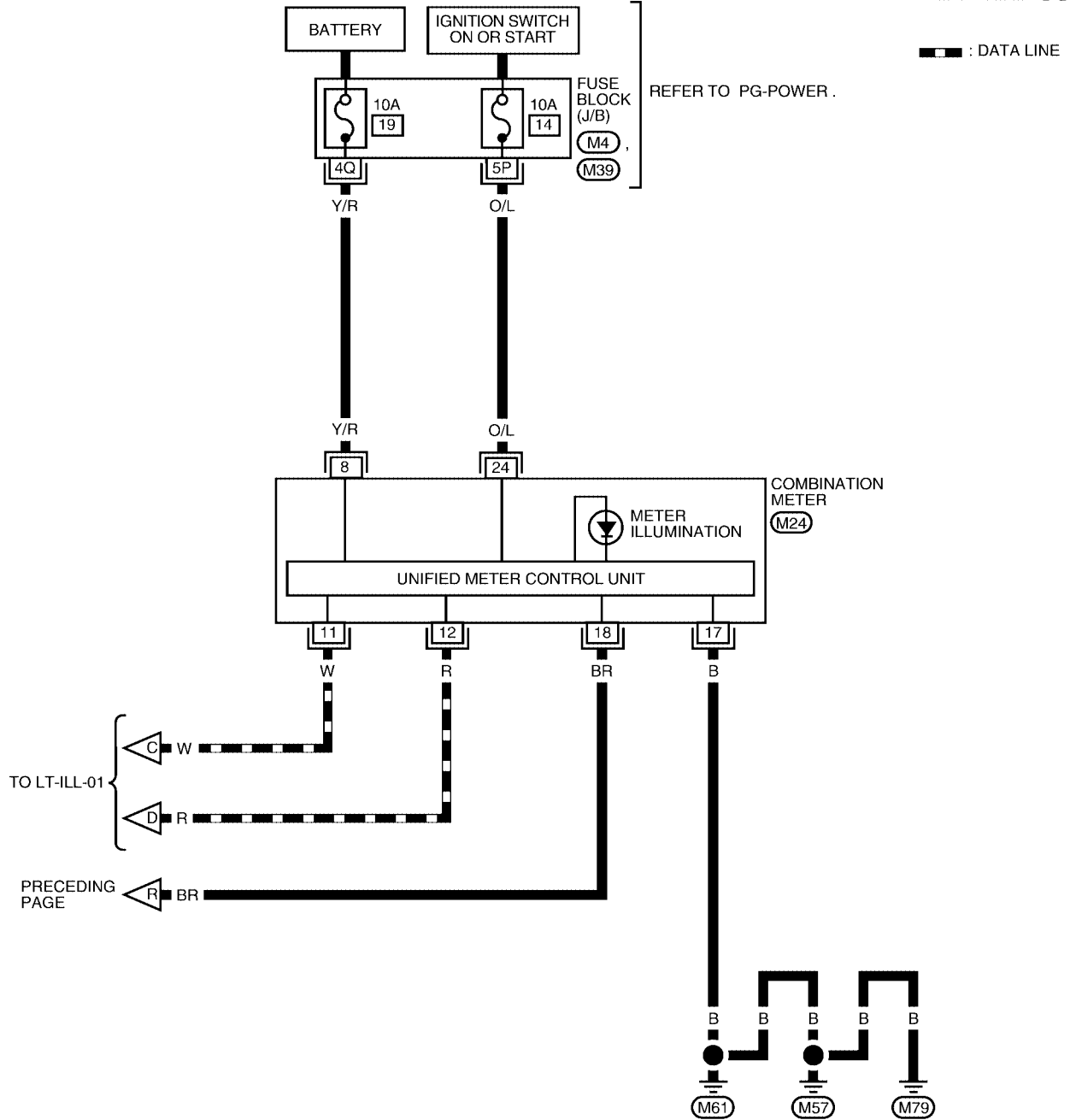

WKWA1095E

ILLUMINATION

Removal and Installation

ILLUMINATION CONTROL SWITCH

EKS0076T

1. Remove cluster lid A. Refer to [IP-13, "COMBINATION METER"](#) .
2. Carefully pry tabs and remove illumination control switch from cluster lid A.
3. Installation is in the reverse order of removal.

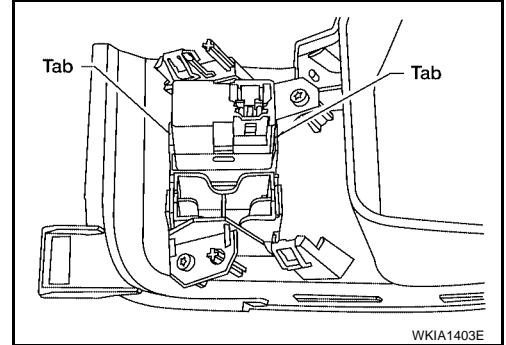

A

B

C

D

E

F

G

H

I

J

LT

L

M

BULB SPECIFICATIONS

BULB SPECIFICATIONS

PFP:26297

Headlamp

EKS0076U

Item	Wattage (W)*
Low	51 (HB4)
High	60 (HB3)

*: Always check with the Parts Department for the latest parts information.

Exterior Lamp

EKS0076V

Item	Wattage (W)*	
Front combination lamp	Turn signal lamp/parking lamp	27/8
	Side marker	3.8
Rear combination lamp	Stop/Tail lamp	27/7
	Turn signal lamp	27
	Back-up lamp	18
	Cargo lamp (tail gate)	16
Fog lamp	37.5	
License plate lamp	5	
High-mounted stop lamp	*	
Cargo lamp (in high-mounted stop lamp)	16	

*: Always check with the Parts Department for the latest parts information.

Interior Lamp/Illumination

EKS0076W

Item	Wattage (W)*
Glove box lamp	3.4
Room/Map lamp	8
A/T device lamp	3
Foot lamp	3.4
Step lamp	3.8
Vanity mirror lamp	1.32
Personal lamp	5
Puddle lamp	8

*: Always check with the Parts Department for the latest parts information.