

# SECTION **DI**

## DRIVER INFORMATION SYSTEM

A  
B  
C

### CONTENTS

D  
E

<p><b>PRECAUTION</b> ..... 3</p> <p style="padding-left: 20px;">Precautions for Supplemental Restraint System (SRS) "AIR BAG" and "SEAT BELT PRE-TENSIONER" ..... 3</p> <p style="padding-left: 20px;">Wiring Diagrams and Trouble Diagnosis ..... 3</p> <p><b>PREPARATION</b> ..... 4</p> <p style="padding-left: 20px;">Commercial Service Tool ..... 4</p> <p><b>COMBINATION METERS</b> ..... 5</p> <p style="padding-left: 20px;">System Description ..... 5</p> <p style="padding-left: 40px;">UNIFIED METER CONTROL UNIT ..... 5</p> <p style="padding-left: 40px;">POWER SUPPLY AND GROUND CIRCUIT ..... 6</p> <p style="padding-left: 40px;">WATER TEMPERATURE GAUGE ..... 6</p> <p style="padding-left: 40px;">ENGINE OIL PRESSURE GAUGE ..... 6</p> <p style="padding-left: 40px;">A/T OIL TEMPERATURE GAUGE ..... 6</p> <p style="padding-left: 40px;">VOLTAGE GAUGE ..... 6</p> <p style="padding-left: 40px;">TACHOMETER ..... 6</p> <p style="padding-left: 40px;">FUEL GAUGE ..... 6</p> <p style="padding-left: 40px;">SPEEDOMETER ..... 6</p> <p style="padding-left: 20px;">CAN Communication System Description ..... 7</p> <p style="padding-left: 20px;">Component Parts and Harness Connector Location... 7</p> <p style="padding-left: 20px;">Combination Meter ..... 8</p> <p style="padding-left: 40px;">CHECK ..... 8</p> <p style="padding-left: 20px;">Circuit Diagram ..... 9</p> <p style="padding-left: 20px;">Wiring Diagram — METER — ..... 10</p> <p style="padding-left: 20px;">Terminals and Reference Value for Combination Meter ..... 12</p> <p style="padding-left: 20px;">Meter/Gauge Operation and Do/Trip Meter ..... 13</p> <p style="padding-left: 40px;">SELF-DIAGNOSIS FUNCTION ..... 13</p> <p style="padding-left: 40px;">HOW TO INITIATE COMBINATION METER SELF-DIAGNOSIS MODE ..... 13</p> <p style="padding-left: 40px;">COMBINATION METER SELF-DIAGNOSIS MODE FUNCTIONS ..... 13</p> <p style="padding-left: 20px;">How to Proceed With Trouble Diagnosis ..... 17</p> <p style="padding-left: 20px;">Diagnosis Flow ..... 17</p> <p style="padding-left: 20px;">Power Supply and Ground Circuit Inspection ..... 18</p> <p style="padding-left: 20px;">Symptom Chart ..... 19</p> <p style="padding-left: 20px;">Vehicle Speed Signal Inspection ..... 19</p> <p style="padding-left: 20px;">Water Temperature Signal Inspection ..... 19</p> <p style="padding-left: 20px;">Engine Speed Signal Inspection ..... 19</p> <p style="padding-left: 20px;">Engine Oil Pressure Signal Inspection ..... 20</p>	<p style="padding-left: 20px;">Fuel Level Sensor Unit Inspection ..... 22</p> <p style="padding-left: 40px;">FUEL LEVEL SENSOR UNIT ..... 22</p> <p style="padding-left: 40px;">LOW-FUEL WARNING LAMP ..... 22</p> <p style="padding-left: 20px;">Fuel Gauge Fluctuates, Indicates Wrong Value, or Varies ..... 24</p> <p style="padding-left: 20px;">Fuel Gauge Does Not Move to Full-position ..... 24</p> <p style="padding-left: 20px;">Electrical Components Inspection ..... 25</p> <p style="padding-left: 40px;">FUEL LEVEL SENSOR UNIT CHECK ..... 25</p> <p style="padding-left: 20px;">Removal and Installation of Combination Meter .... 25</p> <p><b>COMPASS AND THERMOMETER</b> ..... 26</p> <p style="padding-left: 20px;">System Description ..... 26</p> <p style="padding-left: 40px;">OUTSIDE TEMPERATURE DISPLAY ..... 26</p> <p style="padding-left: 40px;">DIRECTION DISPLAY ..... 26</p> <p style="padding-left: 20px;">Wiring Diagram — COMPASS — ..... 27</p> <p style="padding-left: 20px;">Trouble Diagnoses ..... 28</p> <p style="padding-left: 40px;">PRELIMINARY CHECK FOR THERMOMETER.. 28</p> <p style="padding-left: 40px;">INSPECTION/COMPASS AND THERMOMETER ..... 28</p> <p style="padding-left: 20px;">Calibration Procedure for Compass ..... 29</p> <p style="padding-left: 40px;">CORRECTION FUNCTIONS OF COMPASS ..... 29</p> <p style="padding-left: 40px;">INITIAL CORRECTION PROCEDURE FOR COMPASS ..... 29</p> <p><b>WARNING LAMPS</b> ..... 30</p> <p style="padding-left: 20px;">Schematic ..... 30</p> <p style="padding-left: 20px;">Wiring Diagram — WARN — ..... 31</p> <p><b>A/T INDICATOR</b> ..... 37</p> <p style="padding-left: 20px;">Wiring Diagram — AT/IND — ..... 37</p> <p style="padding-left: 20px;">A/T Indicator Does Not Illuminate ..... 38</p> <p><b>WARNING CHIME</b> ..... 39</p> <p style="padding-left: 20px;">Component Parts and Harness Connector Location.. 39</p> <p style="padding-left: 20px;">System Description ..... 40</p> <p style="padding-left: 40px;">FUNCTION ..... 40</p> <p style="padding-left: 40px;">IGNITION KEY WARNING CHIME ..... 40</p> <p style="padding-left: 40px;">LIGHT WARNING CHIME ..... 40</p> <p style="padding-left: 40px;">SEAT BELT WARNING CHIME ..... 41</p> <p style="padding-left: 20px;">CAN Communication System Description ..... 41</p> <p style="padding-left: 20px;">Wiring Diagram — CHIME — ..... 42</p> <p style="padding-left: 20px;">Terminals and Reference Value for BCM ..... 44</p> <p style="padding-left: 20px;">Terminals and Reference Value for Combination Meter ..... 45</p>
--	---

F  
G  
H  
I  
J  
**DI**  
L  
M

How to Proceed With Trouble Diagnosis .....	45	REAR SONAR SENSOR .....	58
Preliminary Check .....	45	Wiring Diagram — SONAR — .....	59
INSPECTION FOR POWER SUPPLY AND GROUND CIRCUIT .....	45	Terminals And Reference Value For Sonar Control Unit .....	61
CONSULT-II Function .....	47	How to Proceed With Trouble Diagnosis .....	61
DIAGNOSTIC ITEMS DESCRIPTION .....	47	Pre-diagnosis Inspection .....	62
CONSULT-II BASIC OPERATION PROCEDURE .....	47	SENSOR STATUS CHECK .....	62
DATA MONITOR .....	48	Self-diagnosis Function .....	62
ACTIVE TEST .....	48	ENTERING DIAGNOSTICS MODE .....	62
SELF-DIAGNOSTIC RESULTS .....	49	REQUESTING NUMBER OF FAULT CODES MODE .....	62
All Warning Chimes Do Not Operate .....	49	REQUESTING FAULT CODES MODE .....	63
Key Warning Chime and Light Warning Chime Do Not Operate (Seat Belt Warning Chime Does Oper- ate) .....	50	IDLING OR CLEARING FAULT CODES MODE...63	
Key Warning Chime Does Not Operate .....	51	Preliminary Check .....	64
Light Warning Chime Does Not Operate .....	53	INSPECTION FOR POWER SUPPLY AND GROUND CIRCUIT .....	64
Seat Belt Warning Chime Does Not Operate .....	54	Symptom Chart .....	65
<b>REAR SONAR SYSTEM .....</b>	<b>56</b>	Component Inspection .....	66
Component Parts and Harness Connector Location..	56	SONAR BUZZER .....	66
System Description .....	57	REAR SONAR SYSTEM OFF SWITCH .....	66
FUNCTION .....	57	REAR SONAR SYSTEM OFF INDICATOR .....	67
REAR SONAR SYSTEM OFF SWITCH .....	57	Removal and Installation of Rear Sonar System ...	67
SONAR BUZZER .....	57	REAR SONAR SENSORS .....	67
		SONAR CONTROL UNIT .....	67

# PRECAUTION

## PRECAUTION

PFP:00011

### Precautions for Supplemental Restraint System (SRS) “AIR BAG” and “SEAT BELT PRE-TENSIONER”

EKS00779

The Supplemental Restraint System such as “AIR BAG” and “SEAT BELT PRE-TENSIONER”, used along with a front seat belt, helps to reduce the risk or severity of injury to the driver and front passenger for certain types of collision. This system includes seat belt switch inputs and dual stage front air bag modules. The SRS system uses the seat belt switches to determine the front air bag deployment, and may only deploy one front air bag, depending on the severity of a collision and whether the front occupants are belted or unbelted. Information necessary to service the system safely is included in the SRS and SB section of this Service Manual.

#### **WARNING:**

- To avoid rendering the SRS inoperative, which could increase the risk of personal injury or death in the event of a collision which would result in air bag inflation, all maintenance must be performed by an authorized NISSAN/INFINITI dealer.
- Improper maintenance, including incorrect removal and installation of the SRS, can lead to personal injury caused by unintentional activation of the system. For removal of Spiral Cable and Air Bag Module, see the SRS section.
- Do not use electrical test equipment on any circuit related to the SRS unless instructed to in this Service Manual. SRS wiring harnesses can be identified by yellow and/or orange harnesses or harness connectors.

### Wiring Diagrams and Trouble Diagnosis

EKS0077A

When you read wiring diagrams, refer to the following:

- Refer to [GI-15, "How to Read Wiring Diagrams"](#) .
- Refer to [PG-4, "POWER SUPPLY ROUTING CIRCUIT"](#) for power distribution circuit.

When you perform trouble diagnosis, refer to the following:

- Refer to [GI-11, "HOW TO FOLLOW TEST GROUPS IN TROUBLE DIAGNOSES"](#) .
- Refer to [GI-27, "How to Perform Efficient Diagnosis for an Electrical Incident"](#) .

A  
B  
C  
D  
E  
F  
G  
H  
I  
J  
DI  
L  
M

# PREPARATION

## PREPARATION

PF0:00002

### Commercial Service Tool

EKS0077B

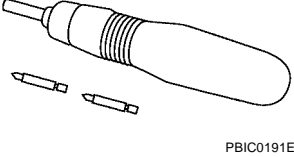
Tool name	Description
<p data-bbox="162 298 272 323">Power tool</p>  <p data-bbox="852 499 925 514">PBIC0191E</p>	<p data-bbox="1015 298 1274 323">Loosening bolts and nuts.</p>

# COMBINATION METERS

## COMBINATION METERS

PFP:24814

### System Description

EKS0077C

#### UNIFIED METER CONTROL UNIT

- Speedometer, odometer, tachometer, fuel gauge, oil pressure gauge, voltage meter, A/T temperature gauge, and water temperature gauge are controlled by the unified meter control unit, which is built into the combination meter.
- Warning indicators are controlled by signals drawn from the CAN communication system, and components connected directly to the combination meter.
- Digital meter is adopted for odometer/trip meters\*, as well as the A/T position indicator display.  
\*The record of the odometer is kept even if the battery cable is disconnected.
- Odometer/trip meters and A/T indicator segments can be checked in diagnosis mode.
- Meters/gauges can be checked in diagnosis mode.

#### Illumination control

The unified meter control unit outputs the speedometer, odometer/trip meters, tachometer, engine oil pressure gauge, voltage meter, A/T indicator, A/T oil temperature gauge, fuel and temperature gauge lighting when the ignition switch is turned on. When the headlamp (combination) switch is turned on, the illumination control switch can be used to adjust the brightness of the combination meter illumination and the odometer/trip meters and meter illumination. When the ignition switch is turned from the OFF to the ON position, the combination meter dial lighting will remain off for 0.7 seconds. For additional combination meter illumination control information, refer to [LT-155. "System Description"](#).

A

B

C

D

E

F

G

H

I

J

DI

L

M

# COMBINATION METERS

---

## POWER SUPPLY AND GROUND CIRCUIT

Power is supplied at all times

- through 10A fuse [No.19, located in the fuse block (J/B)]
- to combination meter terminal 8.

With the ignition switch in the ON or START position, power is supplied

- through 10A fuse [No.14, located in the fuse block (J/B)]
- to combination meter terminal 24.

With the ignition switch in the ACC or ON position, power is supplied

- through 10A fuse [No.4, located in the fuse block (J/B)]
- to combination meter terminal 1.

Ground is supplied

- to combination meter terminal 17
- through body grounds M57, M61 and M79.

## WATER TEMPERATURE GAUGE

The water temperature gauge indicates the engine coolant temperature.

ECM provides an engine coolant temperature signal to combination meter via CAN communication lines.

## ENGINE OIL PRESSURE GAUGE

The engine oil pressure gauge indicates the engine oil pressure.

With the ignition switch in the ON or START position, power is supplied

- through combination meter terminal 22
- to oil pressure sensor terminal 1.

Ground is supplied

- to combination meter terminal 21
- through oil pressure sensor terminal 3.

The combination meter receives the oil pressure signal from oil pressure sensor

- through oil pressure sensor terminal 2
- to combination meter terminal 20.

### NOTE:

**This gauge is not designed to indicate low oil level. Use the oil level gauge to check the oil level.**

## A/T OIL TEMPERATURE GAUGE

The A/T oil temperature gauge indicates the A/T fluid temperature.

TCM provides a A/T oil temperature signal to combination meter via CAN communication lines.

## VOLTAGE GAUGE

The voltage gauge indicates the battery/charging system voltage.

The voltage gauge is regulated by the unified meter control unit.

## TACHOMETER

The tachometer indicates engine speed in revolutions per minute (rpm).

ECM provides an engine speed signal to combination meter via CAN communication lines.

## FUEL GAUGE

The fuel gauge indicates the approximate fuel level in the fuel tank.

The fuel gauge is regulated by the unified meter control unit and a variable resistor signal supplied

- to combination meter terminal 15.
- through fuel level sensor unit and fuel pump terminal 2
- through fuel level sensor unit and fuel pump terminal 5
- from combination meter terminal 16.

## SPEEDOMETER

ABS actuator and electric unit (control unit) provides a vehicle speed signal to the combination meter via CAN communication lines.

# COMBINATION METERS

## CAN Communication System Description

EKS008XM

Refer to [LAN-8, "CAN COMMUNICATION"](#).

## Component Parts and Harness Connector Location

EKS0077D

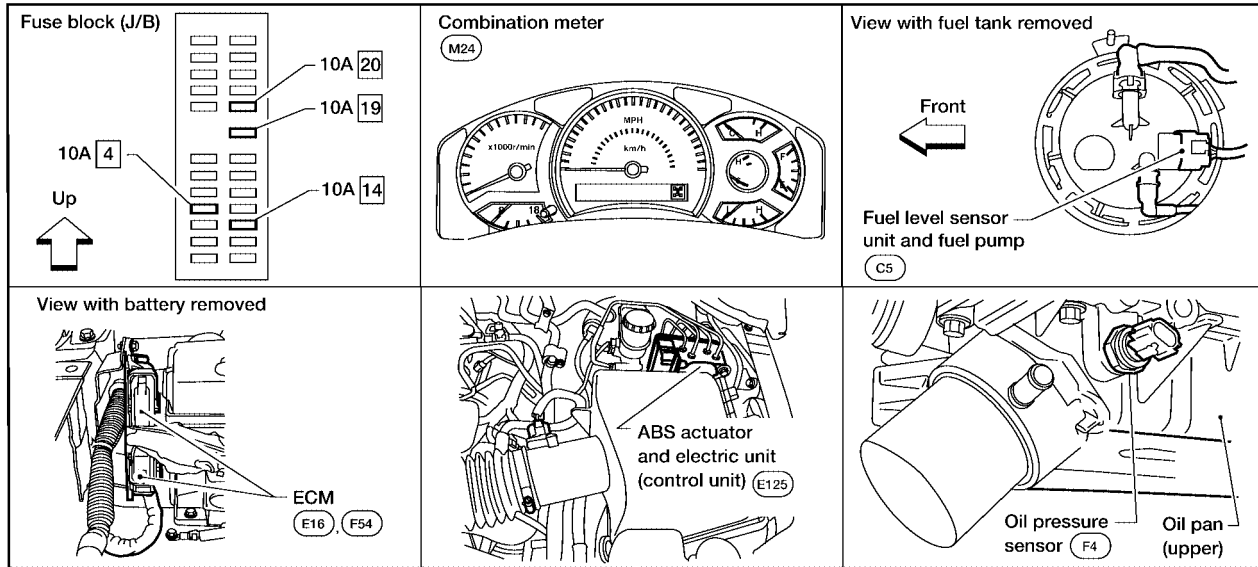

A  
B  
C  
D  
E  
F  
G  
H  
I  
J  
L  
M

WKIA2805E

DI

# COMBINATION METERS

## Combination Meter CHECK

EKS0077E

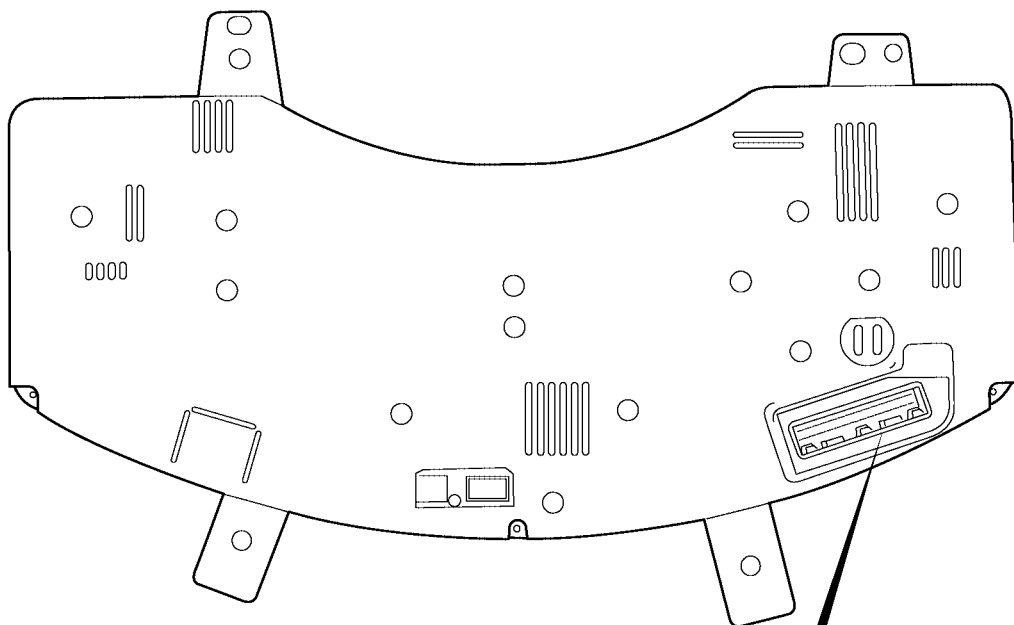
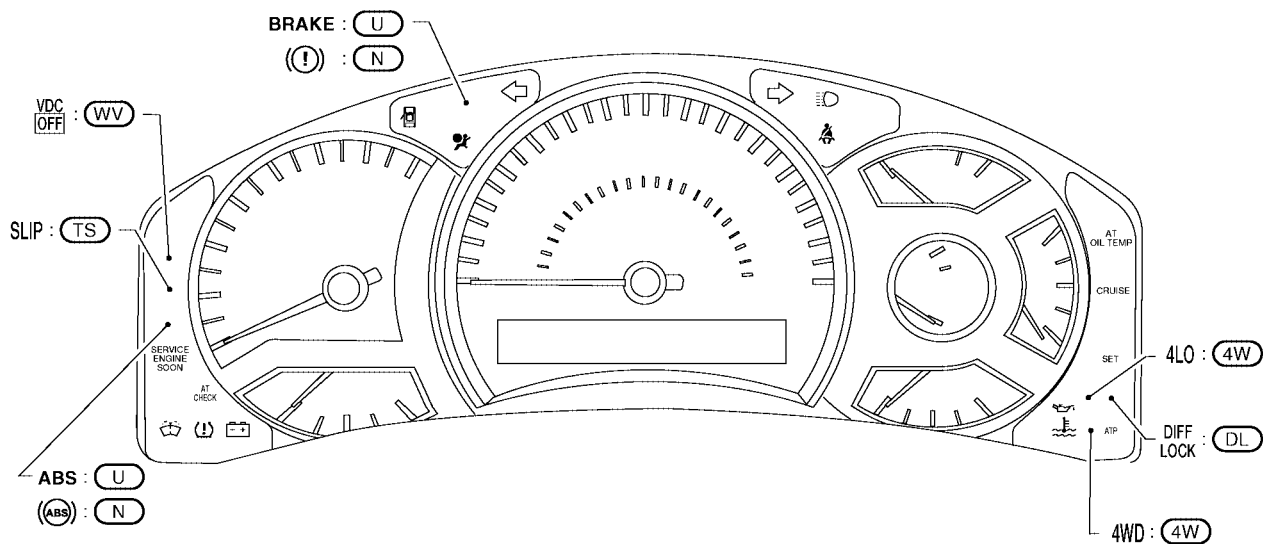

- 4W** : WITH 4-WHEEL DRIVE
- DL** : WITH ELECTRONIC LOCKING REAR DIFFERENTIAL
- N** : CANADA
- TS** : WITH TCS
- U** : USA
- WV** : WITH VDC

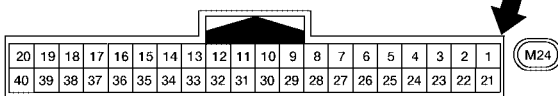

WKIA2806E



# COMBINATION METERS

## Circuit Diagram

EKS0077F

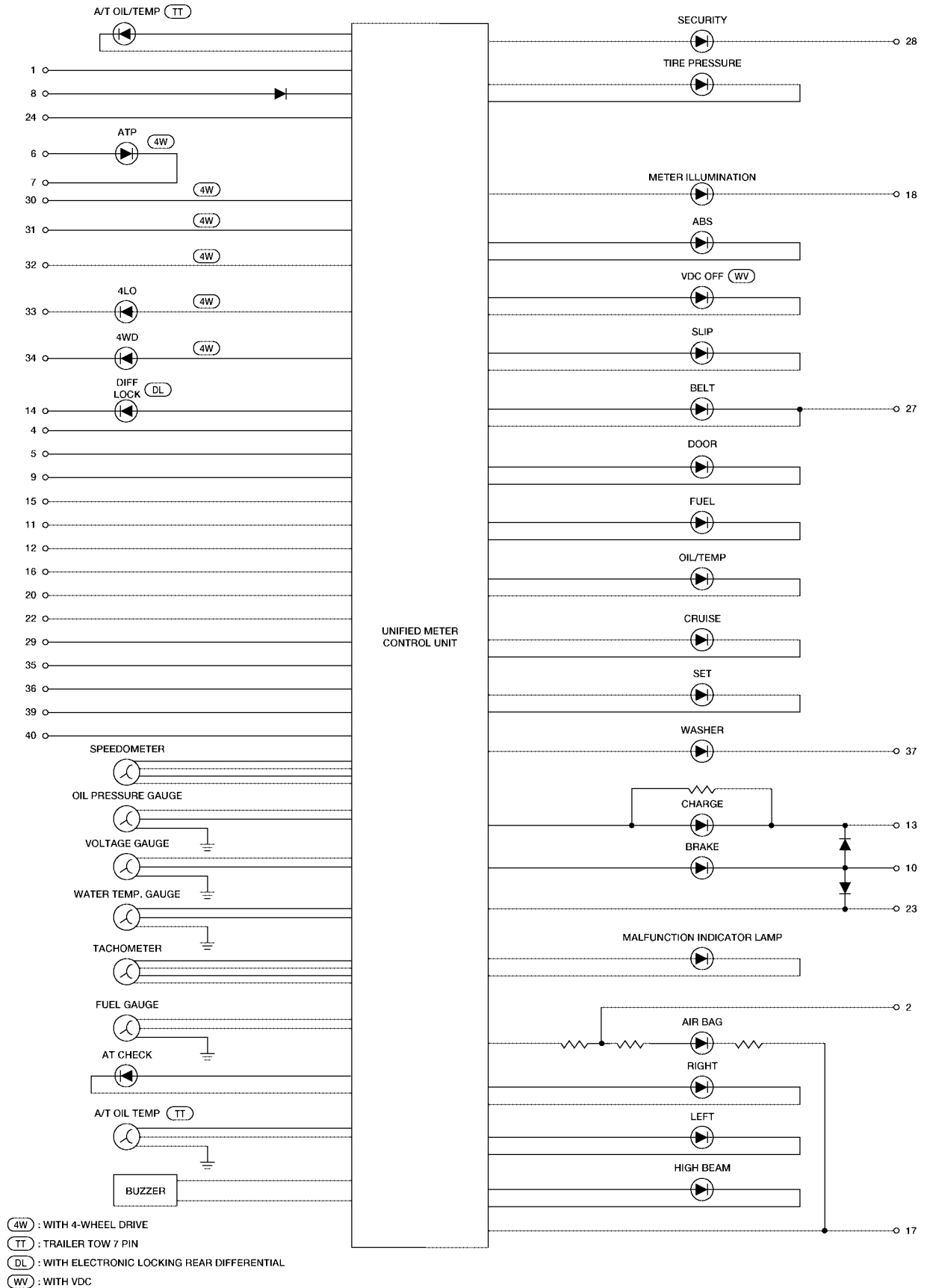

A  
B  
C  
D  
E  
F  
G  
H  
I  
J  
DI  
L  
M

# COMBINATION METERS

## Wiring Diagram — METER —

EKS0077G

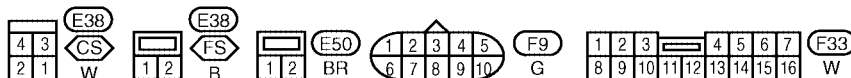
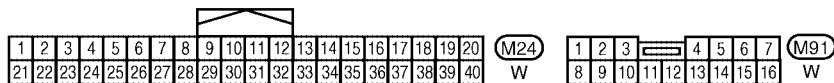
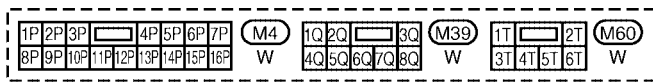
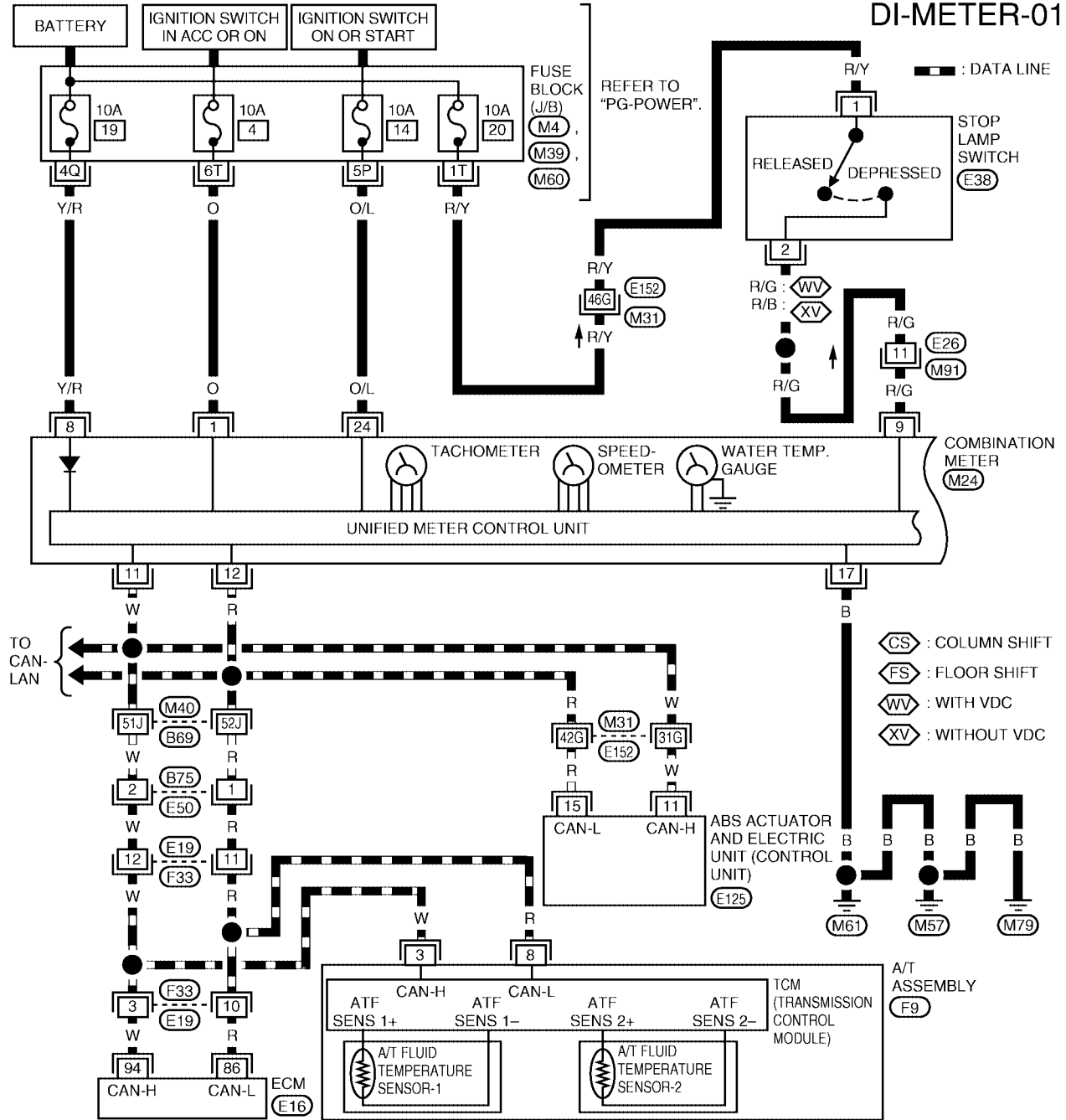

REFER TO THE FOLLOWING.

(E16), (E125) - ELECTRICAL UNITS

(M31), (M40) - SUPER MULTIPLE JUNCTION (SMJ)

WKWA1536E

# COMBINATION METERS

## DI-METER-02

: WITH NAVI

: TRAILER TOW 7 PIN

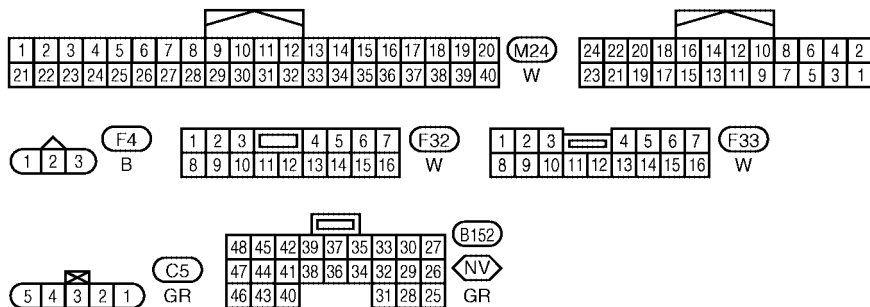
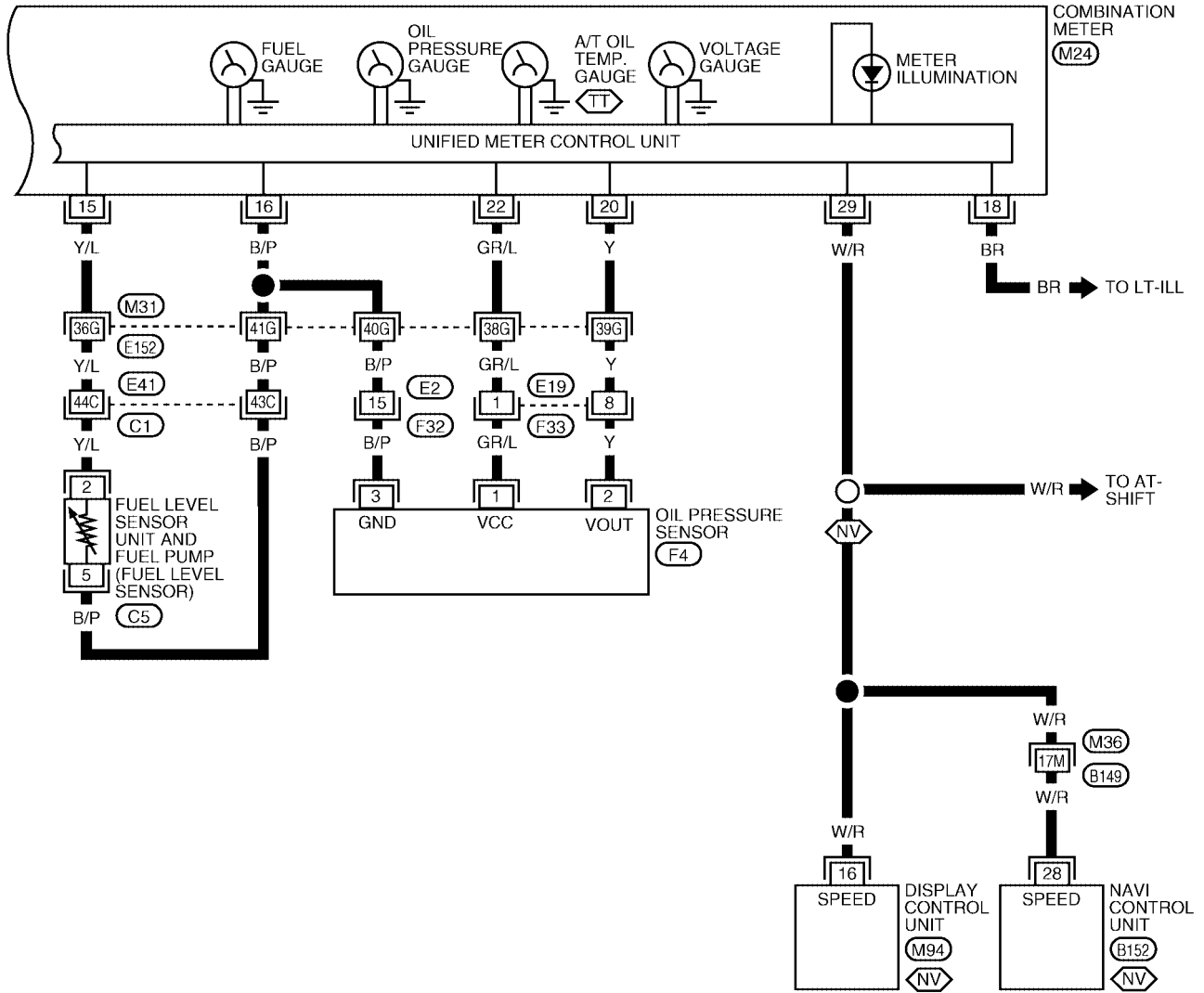

REFER TO THE FOLLOWING  
 , , - SUPER  
 MULTIPLE JUNCTION (SMJ)

WKWA1516E

# COMBINATION METERS

## Terminals and Reference Value for Combination Meter

EKS0077H

Terminal No.	Wire color	Item	Condition		Reference value (V) (Approx.)
			Ignition switch	Operation or condition	
1	O	Ignition switch ACC or ON	ACC	—	Battery voltage
8	Y/R	Battery power supply	OFF	—	Battery voltage
9	R/G	Stop lamp switch input	OFF	Brake pedal pressed	Battery voltage
				Brake pedal released	0V
10	P/B	Brake fluid level switch input	—	Brake fluid level low	Refer to <a href="#">BRC-138, "Brake Fluid Level Sensor System Inspection"</a> .
11	W	CAN-H	—	—	—
12	R	CAN-L	—	—	—
15	Y/L	Fuel level sensor signal	—	—	Refer to <a href="#">DI-22, "Fuel Level Sensor Unit Inspection"</a> .
16	B/P	Fuel level sensor and oil pressure sensor ground	ON	—	Refer to <a href="#">DI-22, "Fuel Level Sensor Unit Inspection"</a> .
17	B	Ground	—	—	0V
18	BR	Illumination control switch	—	Lighting switch ON	Refer to <a href="#">LT-155, "ILLUMINATION OPERATION BY LIGHTING SWITCH"</a> .
20	Y	Oil pressure sensor signal	ON	—	0 - 5V
22	GR/L	Oil pressure sensor power supply	ON	—	5V
24	O/L	Ignition switch ON or START	ON	—	Battery voltage
29	W/R	Vehicle speed signal output	ON	Vehicle speed signal received over CAN	Refer to <a href="#">AV-71, "System Description"</a> (without NAVI) or <a href="#">AV-79, "System Description"</a> (with NAVI).

# COMBINATION METERS

EKS00771

## Meter/Gauge Operation and Do/Trip Meter SELF-DIAGNOSIS FUNCTION

The following items can be checked during Combination Meter Self-Diagnosis Mode.

- Gauge sweep and present gauge values.
- Illuminates all odometer, fuel, and engine temperature segments.
- Illuminates all micro controlled lamps/LEDs regardless of switch configuration.
- Displays estimated present battery voltage.
- Displays seat belt buckle switch LH status.

### HOW TO INITIATE COMBINATION METER SELF- DIAGNOSIS MODE

#### NOTE:

Once entered, Combination Meter Self-Diagnosis Mode will function with the ignition switch in ON or START. Combination Meter Self-Diagnosis Mode will exit upon turning the ignition switch to OFF or ACC. To initiate Combination Meter Self-Diagnosis Mode, refer to the following procedure.

1. Turn the ignition switch ON, while holding the odometer/trip meter switch for 5 - 8 seconds.

#### NOTE:

If the diagnosis function is activated the odometer/trip meter will display tESt.

### COMBINATION METER SELF-DIAGNOSIS MODE FUNCTIONS

To interpret Combination Meter Self-Diagnosis Mode functions, refer to the following table.

Event	Odometer Display	Description of Test/Data	Notes:
Odometer/trip meter A/B switch held from 5 to 8 seconds (or until released)	tESt		Initiating self-diagnosis mode
Odometer/trip meter A/B switch engaged and released = next test requested	rXXXX, FAIL	Return to normal operation of all lamps/LEDs and displays hex ROM rev. If a ROM checksum fault exists, display alternates between "r XXXX" and "FAIL".	
Next test requested	nrXXXX	Displays hex ROM rev as stored in NVM.	
Next test requested	GAGE	Performs sweep of all gauges, then displays present gauge values. Performs checksum tests on ROM and EE.	Gauges sweep within 10 seconds
Next test requested	(All segments illuminated)	Lights all odometer/trip meter, fuel, and engine temperature display segments.	Initiating self-diagnosis mode complete
Next test requested	bulb	Illuminates all micro-controlled lamps/LEDs regardless of SW configuration.	
Next test requested	EE XX, FAIL	Hex EE level. If EE checksum fault exists, display alternates between "EE XX" and "FAIL".	
Next test requested	dtXXXX	Hex coding of final manufacturing test date.	

## COMBINATION METERS

Event	Odometer Display	Description of Test/Data	Notes:
Next test requested	Sc1XX	Displays 8-bit software configuration value in Hex format.	Bit Coding 7-3 = reserved for future use 2 = TCS/VDC 0 = not present 1 = present 1 = Shift type 0 = Column shift 1 = Floor shift 0 = ICC 0 = not present 1 = present
Next test requested	Sc2XX	Displays 8-bit software configuration value in Hex format.	Bit coding 7-0 = Reserved for future use
Next test requested	EprXX	Displays 8-bit software configuration value in Hex format.	Bit Coding 7-2 = reserved for future use 1 = A/T Oil Temp (gauge) 0 = not present 1 = present 1 = Odo Units 0 = kilometers 1 = miles
Next test requested	1nFXX	Displays 8-bit market info value in Hex format.	\$31 = USA \$2A = Canada
Next test requested	cYLXX	Displays 8-bit engine configuration value in Hex format.	\$08 = 8 cylinder \$06 = 6 cylinder
Next test requested	FFXXXX	Displays 16-bit fuel flow constant "Q" in tenths of cc/min in Hex format.	\$0000 - \$FFFF
Next test requested	tF	Displays 16-bit tire factor "A" in hundredths in Hex format.	\$0000 - \$FFFF
Next test requested	ot1XX	Displays oil pressure tell-tale "on" threshold in A/D counts in Hex format.	\$00 - \$FF
Next test requested	ot0XX	Displays oil pressure tell-tale "off" threshold in A/D counts in Hex format.	\$00 - \$FF
Next test requested	XXXXX	Raw uncompensated english speed value in hundredths of MPH. Speedometer indicates present speed.	Will display "-----" if message is not received. Will display "99999" if data received is invalid
Next test requested	XXXXX	Raw uncompensated metric speed value in hundredths of KPH. Speedometer indicates present speed.	Will display "-----" if message is not received. Will display "99999" if data received is invalid
Next test requested	tXXXX	Tachometer value in RPM. Tachometer indicates present RPM.	Will display "-----" if message is not received.
Next test requested	F1 XXXX	Present ratioed fuel level A/D input 1 in decimal format. Fuel gauge indicates present filtered level.	000-009 = Short circuit 010-254 = Normal range 255 = Open circuit --- = Missing 5 seconds
Next test requested	XXXXC	Last temperature gauge input value in degrees C. Temperature gauge indicates present filtered temperature.	Will display "----"C if message is not received. Will display "999" if data received is invalid.

## COMBINATION METERS

Event	Odometer Display	Description of Test/Data	Notes:	
Next test requested	BAtXX.X	Estimated present battery voltage.		A
Next test requested	rES -X	Seat belt buckle switch LH status.	1= Buckled 0 = Unbuckled	B
Next test requested	PA -XX	Hex value port A.		
Next test requested	Pb -XX	Hex value port B.		C
Next test requested	PE -XX	Hex value port E.		
Next test requested	PL -XX	Hex value port L.		
Next test requested	P6 -XX	Hex value port K.		D
Next test requested	Pn -XX	Hex value port M.		
Next test requested	PP -XX	Hex value port P.		
Next test requested	PS -XX	Hex value port S.		E
Next test requested	Pt -XX	Hex value port T.		
Next test requested	Pu -XX	Hex value port U.		F
Next test requested	P4 -XX	Hex value port V.		
Next test requested	Puu -XX	Hex value port W.		
Next test requested	A01XXX	A/D port A/D value (non-ratioed).	0-255	G
Next test requested	A02XXX	A/D port A/D value (non-ratioed).	0-255	H
Next test requested	A03XXX	A/D port A/D value (non-ratioed).	0-255	
Next test requested	A04XXX	A/D port A/D value (non-ratioed).	0-255	I
Next test requested	A05XXX	A/D port A/D value (non-ratioed).	0-255	
Next test requested	A06XXX	A/D port A/D value (non-ratioed).	0-255	J
Next test requested	A07XXX	A/D port A/D value (non-ratioed).	0-255	DI
Next test requested	A08XXX	A/D port A/D value (non-ratioed).	0-255	
Next test requested	A09XXX	A/D port A/D value (non-ratioed).	0-255	L
Next test requested	A10XXX	A/D port A/D value (non-ratioed).	0-255	
Next test requested	A11XXX	A/D port A/D value (non-ratioed).	0-255	M
Next test requested	A12XXX	A/D port A/D value (non-ratioed).	0-255	
Next test requested	A13XXX	A/D port A/D value (non-ratioed).	0-255	
Next test requested	A14XXX	A/D port A/D value (non-ratioed).	0-255	
Next test requested	A15XXX	A/D port A/D value (non-ratioed).	0-255	
Next test requested	PA0-XX	Hex value representing state of A/D ports 0-7.		
Next test requested	PA1-XX	Hex value representing state of A/D ports 0-7.		

## COMBINATION METERS

Event	Odometer Display	Description of Test/Data	Notes:
Next test requested	Thr-XXX	Decimal value of thermistor A/D reading.	0-255
Next test requested	D-HI	Meter/LCD Illumination.	Full daytime brightness all LCD segments active
Next test requested	N-HI	Meter/LCD Illumination.	Full nighttime brightness all LCD segments active
Next test requested	N-LO	Meter/LCD Illumination.	Min. nighttime brightness all LCD segments active
Next test requested	GAGE		Return to beginning of self-diagnosis.



# COMBINATION METERS

## How to Proceed With Trouble Diagnosis

EKS0077J

1. Confirm the symptom or customer complaint.
2. Perform diagnosis according to diagnosis flow. Refer to [DI-17, "Diagnosis Flow"](#) .
3. According to the symptom chart, repair or replace the cause of the symptom.
4. Does the meter operate normally? If so, go to 5. If not, go to 2.
5. Inspection End.

## Diagnosis Flow

EKS0077K

### 1. CHECK WARNING INDICATOR ILLUMINATION

1. Turn ignition switch ON.
2. Make sure warning indicators (such as malfunction indicator lamp and oil pressure low/coolant temperature high warning indicator) illuminate.

Do warning indicators illuminate?

YES >> GO TO 2.

NO >> Check ignition power supply system of combination meter. Refer to [DI-18, "Power Supply and Ground Circuit Inspection"](#) .

### 2. CHECK SELF-DIAGNOSIS OPERATION OF COMBINATION METER

Perform combination meter self-diagnosis. Refer to [DI-13, "SELF-DIAGNOSIS FUNCTION"](#) .

Does self-diagnosis function operate?

YES >> GO TO 3.

NO >> Check the following.

- Combination meter power supply and ground circuit. Refer to [DI-18, "Power Supply and Ground Circuit Inspection"](#) .

### 3. CHECK ODOMETER OPERATION

Check segment display status of odometer.

Is the display normal?

YES >> GO TO 4.

NO >> Replace the combination meter. Refer to [DI-25, "Removal and Installation of Combination Meter"](#) .

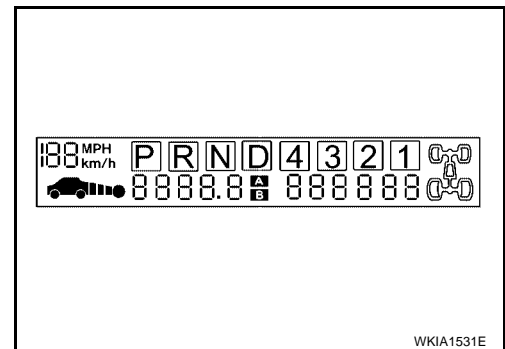

### 4. CHECK COMBINATION METER CIRCUIT

Check indication of each meter/gauge in self-diagnosis mode.

OK or NG

OK >> Go to [DI-19, "Symptom Chart"](#) .

NG >> Replace the combination meter. Refer to [DI-25, "Removal and Installation of Combination Meter"](#) .

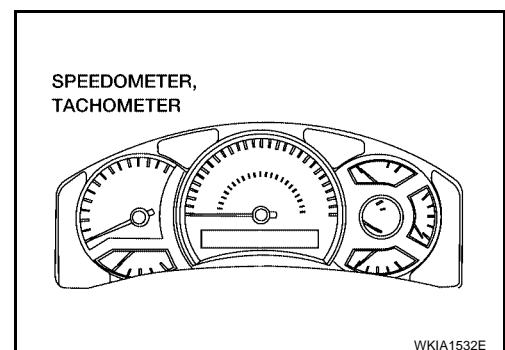

# COMBINATION METERS

EKS0077L

## Power Supply and Ground Circuit Inspection

### 1. CHECK FUSES

Check for blown combination meter fuses.

Unit	Power source	Fuse No.
Combination meter	Battery	19
	Ignition switch ON or START	14
	Ignition switch ACC or ON	4

Refer to [DI-10, "Wiring Diagram — METER —"](#).

#### OK or NG

OK >> GO TO 2.

NG >> If fuse is blown, be sure to eliminate cause of malfunction before installing new fuse. Refer to [PG-4, "POWER SUPPLY ROUTING CIRCUIT"](#).

### 2. CHECK POWER SUPPLY CIRCUIT

- Disconnect combination meter connector.
- Check voltage between combination meter harness connector terminals and ground.

Terminals		Ignition switch position			
(+)		(-)	OFF	ACC	ON
Connector	Terminal (Wire color)				
M24	1 (O)	Ground	0V	Battery voltage	Battery voltage
	8 (Y/R)		Battery voltage	Battery voltage	Battery voltage
	24 (O/L)		0V	0V	Battery voltage

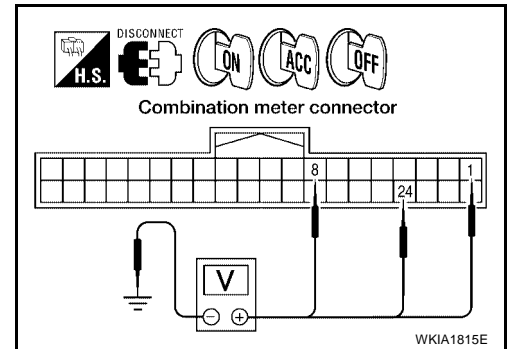

#### OK or NG

OK >> GO TO 3.

NG >> Check the harness for open between combination meter and fuse.

### 3. CHECK GROUND CIRCUIT

- Turn ignition switch OFF.
- Check continuity between combination meter harness connector terminals and ground.

Terminals		(-)	Continuity
(+)			
Connector	Terminal (Wire color)		
M24	17 (B)	Ground	Yes

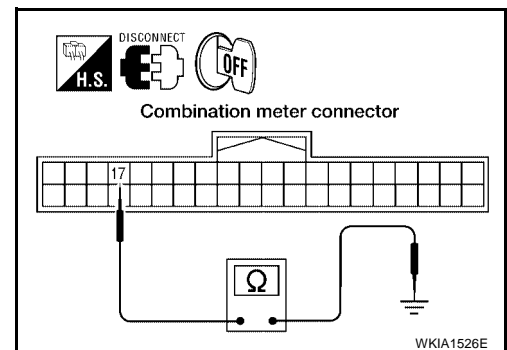

#### OK or NG

OK >> Inspection End.

NG >> Repair harness or connector.

# COMBINATION METERS

## Symptom Chart

EKS0077M

Trouble phenomenon	Possible cause
Improper tachometer indication.	Refer to <a href="#">DI-19, "Engine Speed Signal Inspection"</a> .
Improper water temperature gauge indication.	Refer to <a href="#">DI-19, "Water Temperature Signal Inspection"</a> .
Improper speedometer or odometer.	Refer to <a href="#">DI-19, "Vehicle Speed Signal Inspection"</a> .
Improper engine oil pressure gauge indication.	Refer to <a href="#">DI-20, "Engine Oil Pressure Signal Inspection"</a> .
Improper A/T oil temperature gauge indication.	Refer to <a href="#">AT-134, "DTC P1710 A/T FLUID TEMPERATURE SENSOR CIRCUIT"</a> .
Improper voltage meter indication.	Refer to <a href="#">IP-13, "COMBINATION METER"</a> .
Improper fuel gauge indication.	Refer to <a href="#">DI-22, "Fuel Level Sensor Unit Inspection"</a> .
Fuel warning lamp indication is irregular.	
More than one gauge does not give proper indication.	Replace the combination meter. Refer to <a href="#">DI-25, "Removal and Installation of Combination Meter"</a> .
Improper A/T position indication.	Refer to <a href="#">DI-37, "A/T INDICATOR"</a> .
Illumination control does not operate properly.	Refer to <a href="#">LT-154, "ILLUMINATION"</a> .

## Vehicle Speed Signal Inspection

EKS0077N

### 1. CHECK ABS ACTUATOR AND ELECTRIC UNIT (CONTROL UNIT) SELF-DIAGNOSIS

Perform ABS actuator and electric unit (control unit) self-diagnosis. Refer to [BRC-24, "SELF-DIAGNOSIS"](#) .

#### Self-diagnostic result content

No malfunction detected>>Replace the combination meter. Refer to [DI-25, "Removal and Installation of Combination Meter"](#) .

Malfunction detected>>Perform the "Diagnostic Procedure" for displayed DTC.

## Water Temperature Signal Inspection

EKS0077O

### 1. CHECK ECM SELF-DIAGNOSIS

1. Perform ECM self-diagnosis. Refer to [EC-106, "SELF-DIAG RESULTS MODE"](#) .

#### Self-diagnostic result content

No malfunction detected>>Replace the combination meter. Refer to [DI-25, "Removal and Installation of Combination Meter"](#) .

Malfunction detected>>Perform "Diagnostic procedure" for displayed DTC.

## Engine Speed Signal Inspection

EKS0077P

### 1. CHECK ECM SELF-DIAGNOSIS

1. Perform ECM self-diagnosis. Refer to [EC-106, "SELF-DIAG RESULTS MODE"](#) .

#### Self-diagnostic result content

No malfunction detected>>Replace the combination meter. Refer to [DI-25, "Removal and Installation of Combination Meter"](#) .

Malfunction detected>>Perform "Diagnostic procedure" for displayed DTC.

# COMBINATION METERS

EKS007RY

## Engine Oil Pressure Signal Inspection

### 1. CHECK OIL PRESSURE SENSOR SIGNAL

1. Turn ignition switch ON.
2. Check voltage between combination meter harness connector M24 terminal 20 (Y) and ground.

Terminals			Condition	Voltage (V)
(+)		(-)		
Connector	Terminal (Wire color)			
M24	20 (Y)	Ground	When ignition switch is in ON position. (Engine stopped.)	Yes
			Engine running. (Idle speed)	Yes

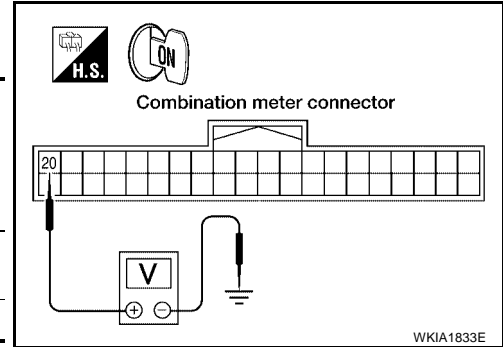

OK or NG

- OK >> Replace combination meter. Refer to [IP-13, "COMBINATION METER"](#) .  
 NG >> GO TO 2.

### 2. CHECK OIL PRESSURE SENSOR SIGNAL

1. Turn ignition switch OFF.
2. Disconnect oil pressure sensor connector F4.
3. Turn ignition switch ON.
4. Check voltage between combination meter harness connector M24 terminal 22 (GR/L) and ground.

**Voltage : Approx. 5V**

OK or NG

- OK >> GO TO 3.  
 NG >> Replace combination meter. Refer to [IP-13, "COMBINATION METER"](#) .

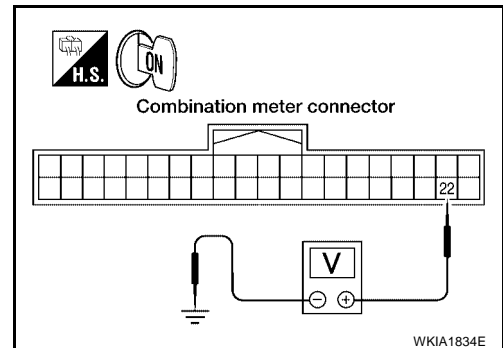

### 3. CHECK OIL PRESSURE SENSOR POWER SUPPLY CIRCUIT

1. Turn ignition switch OFF.
2. Disconnect combination connector M24.
3. Check continuity between combination meter harness connector M24 terminal 22 (GR/L) and oil pressure sensor harness connector F4 terminal 1 (GR/L).

**Continuity should exist.**

4. Check continuity between combination meter harness connector M24 terminal 22 (GR/L) and ground.

**Continuity should not exist.**

OK or NG

- OK >> GO TO 4.  
 NG >> Repair harness or connector.

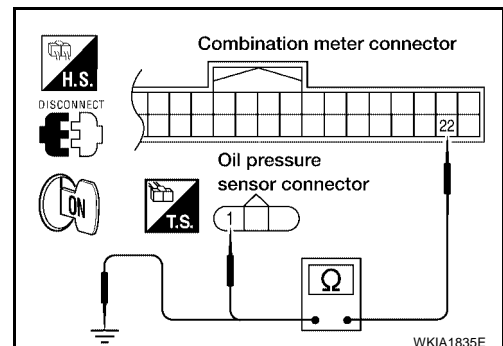

# COMBINATION METERS

## 4. CHECK OIL PRESSURE SENSOR SIGNAL CIRCUIT

1. Check continuity between combination meter harness connector M24 terminal 20 (Y) and oil pressure sensor harness connector F4 terminal 2 (Y).

**Continuity should exist.**

2. Check continuity between combination meter harness connector M24 terminal 20 (Y) and ground.

**Continuity should not exist.**

OK or NG

- OK >> GO TO 5.
- NG >> Repair harness or connector.

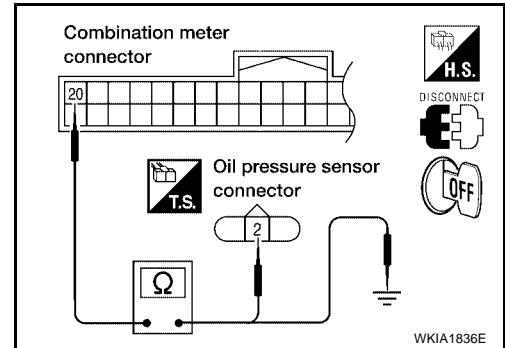

## 5. CHECK OIL PRESSURE SENSOR GROUND CIRCUIT

Check continuity between combination meter harness connector M24 terminal 16 (B/P) and oil pressure sensor harness connector F4 terminal 3 (B/P).

**Continuity should exist.**

OK or NG

- OK >> Replace oil pressure sensor.
- NG >> Repair harness or connector.

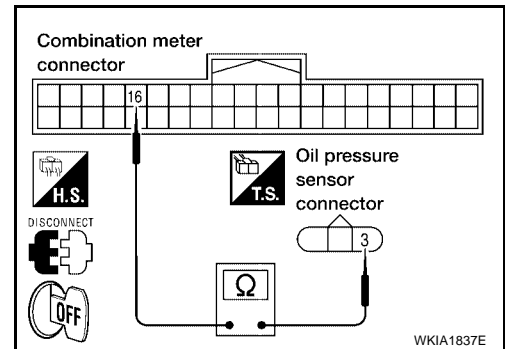

A  
B  
C  
D  
E  
F  
G  
H  
I  
J  
L  
M

DI

# COMBINATION METERS

EKS0077Q

## Fuel Level Sensor Unit Inspection

### FUEL LEVEL SENSOR UNIT

The following symptoms do not indicate a malfunction.

- Depending on vehicle position or driving circumstance, the fuel in the tank shifts and the indication may fluctuate.
- If the vehicle is fueled with the ignition switch ON, the indication will update slowly.
- If the vehicle is tilted when the ignition switch is turned ON, fuel in the tank may flow to one direction resulting in a change of reading.

### LOW-FUEL WARNING LAMP

Depending on vehicle posture or driving circumstances, the fuel level in the tank varies, and the warning lamp ON timing may be changed.

## 1. CHECK HARNESS CONNECTOR

Check combination meter and fuel level sensor unit and fuel pump terminals (meter-side, and harness-side) for poor connection.

OK or NG

- OK >> GO TO 2.  
NG >> Repair or replace terminals or connectors.

## 2. CHECK HARNESS CONNECTOR OUTPUT SIGNAL

1. Disconnect fuel level sensor unit and fuel pump connector.
2. Turn ignition switch ON.
3. Check voltage between combination meter harness connector M24 terminal 15 (Y/L) and ground.

**Battery voltage**

OK or NG

- OK >> GO TO 3.  
NG >> Replace the combination meter. Refer to [DI-25](#), "[Removal and Installation of Combination Meter](#)".

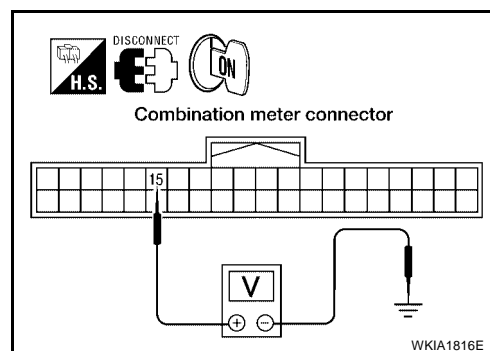

## 3. CHECK HARNESS FOR OPEN OR SHORT CIRCUIT

1. Turn ignition switch OFF.
2. Disconnect combination meter connector M24.
3. Check continuity between combination meter harness connector M24 terminal 15 (Y/L) and fuel level sensor unit and fuel pump harness connector C5 terminal 2 (Y/L).

**Continuity should exist.**

4. Check continuity between fuel level sensor unit and fuel pump harness connector C5 terminal 2 (Y/L) and ground.

**Continuity should not exist.**

OK or NG

- OK >> GO TO 4.  
NG >> Repair harness or connector.

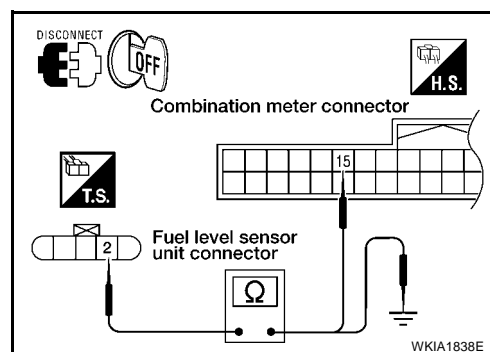

# COMBINATION METERS

## 4. CHECK FUEL LEVEL SENSOR CIRCUIT

1. Check continuity between combination meter harness connector M24 terminal 16 (B/P) and fuel level sensor unit and fuel pump harness connector C5 terminal 5 (B/P).

**Continuity should exist.**

2. Check continuity between fuel level sensor unit and fuel pump harness connector C5 terminal 5 (B/P) and ground.

**Continuity should not exist.**

OK or NG

- OK >> GO TO 5.
- NG >> Repair harness or connector.

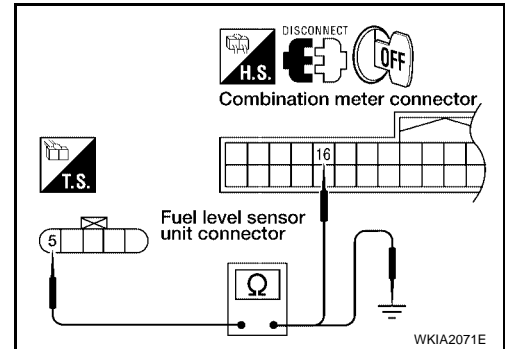

## 5. CHECK FUEL LEVEL SENSOR UNIT

Check the fuel level sensor unit. Refer to [DI-25, "FUEL LEVEL SENSOR UNIT CHECK"](#).

OK or NG

- OK >> GO TO 6.
- NG >> Replace the fuel level sensor unit. Refer to [FL-5, "Removal and Installation"](#).

## 6. CHECK INSTALLATION CONDITION

Check fuel level sensor unit installation, and determine whether the float arm interferes or binds with any of the internal components in the fuel tank.

OK or NG

- OK >> Replace the combination meter. Refer to [DI-25, "Removal and Installation of Combination Meter"](#).
- NG >> Install the fuel level sensor unit properly.

A  
B  
C  
D  
E  
F  
G  
H  
I  
J  
L  
M

DI

# COMBINATION METERS

---

## Fuel Gauge Fluctuates, Indicates Wrong Value, or Varies

EKS0077R

### 1. CHECK FUEL GAUGE FLUCTUATION

---

Test drive vehicle to see if gauge fluctuates only during driving or just before or just after stopping.

Does the indication value vary only during driving or just before or just after stopping?

- YES >> The fluctuation may be caused by fuel level change in the fuel tank. Condition is normal.  
NO >> Ask the customer about the situation when the symptom occurs in detail, Refer to [DI-22, "Fuel Level Sensor Unit Inspection"](#).

## Fuel Gauge Does Not Move to Full-position

EKS0077S

### 1. CHECK POINTER MOVEMENT TO FULL-POSITION

---

Does it take a long time for the pointer to move to full-position?

YES or NO

- YES >> GO TO 2.  
NO >> GO TO 3.

### 2. CHECK IGNITION SWITCH POSITION

---

Was the vehicle fueled with the ignition switch ON?

YES or NO

- YES >> Be sure to fuel the vehicle with the ignition switch OFF. Otherwise, it will take a long time for the pointer to move to full-position because of the characteristic of the fuel gauge.  
NO >> GO TO 3.

### 3. OBSERVE VEHICLE POSITION

---

Is the vehicle parked on an incline?

YES or NO

- YES >> Check the fuel level indication with vehicle on a level surface.  
NO >> GO TO 4.

### 4. CHECK POINTER MOVEMENT TO EMPTY-POSITION

---

During driving, does the fuel gauge move gradually toward empty-position?

YES or NO

- YES >> Check the fuel level sensor unit. Refer to [DI-25, "FUEL LEVEL SENSOR UNIT CHECK"](#).  
NO >> Check fuel level sensor unit installation, and determine whether the float arm interferes or binds with any of the internal components in the fuel tank.



# COMBINATION METERS

## Electrical Components Inspection FUEL LEVEL SENSOR UNIT CHECK

EKS0077T

For removal, refer to [FL-5, "Removal and Installation"](#) .

### Check Fuel Level Sensor Unit and Fuel Pump

Check resistance between fuel level sensor unit and fuel pump connector terminals 2 and 5.

Terminals		Float position mm (in)			Resistance value $\Omega$ (Approx.)
2	5	*1	Empty	25.86 (1.02)	81.66
		*2	Full	254.6 (10.02)	6.98

\*1 and \*2: When float rod is in contact with stopper.

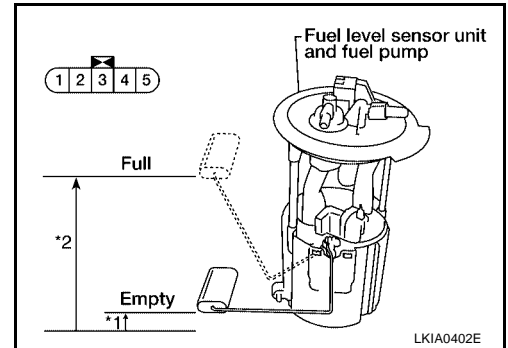

### Removal and Installation of Combination Meter

EKS0077U

Refer to [IP-13, "COMBINATION METER"](#) .

A  
B  
C  
D  
E  
F  
G  
H  
I  
J  
DI  
L  
M

DI

# COMPASS AND THERMOMETER

## COMPASS AND THERMOMETER

PF2:24835

### System Description

EKS008X8

The compass and thermometer are an integral part of the auto anti-dazzling inside mirror. This unit displays the following items:

- Earth magnetism and heading direction of vehicle.
- Outside air temperature.
- Caution for frozen road surfaces.

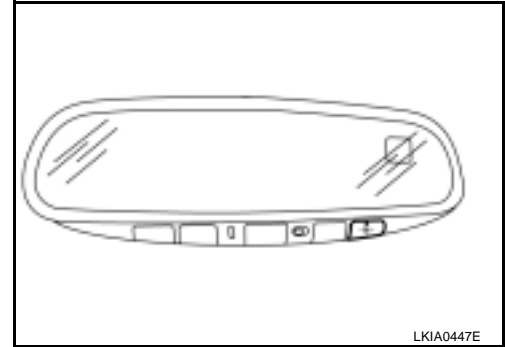

LKIA0447E

### OUTSIDE TEMPERATURE DISPLAY

Push the mode switch when the ignition switch is in the ACC or ON position. The outside temperature will be displayed in "°F". To change the indication from "°F" to "°C", push and hold the mode switch for about 3 seconds until the display begins to flash. Press the mode switch again to toggle between "°F" and "°C".

### DIRECTION DISPLAY

Push the mode switch when the ignition switch is in the ACC or ON position. The direction will be displayed.

# COMPASS AND THERMOMETER

## Wiring Diagram — COMPASS —

EKS0077W

DI-COMPAS-01

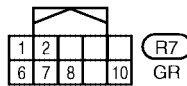
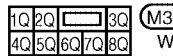
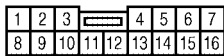
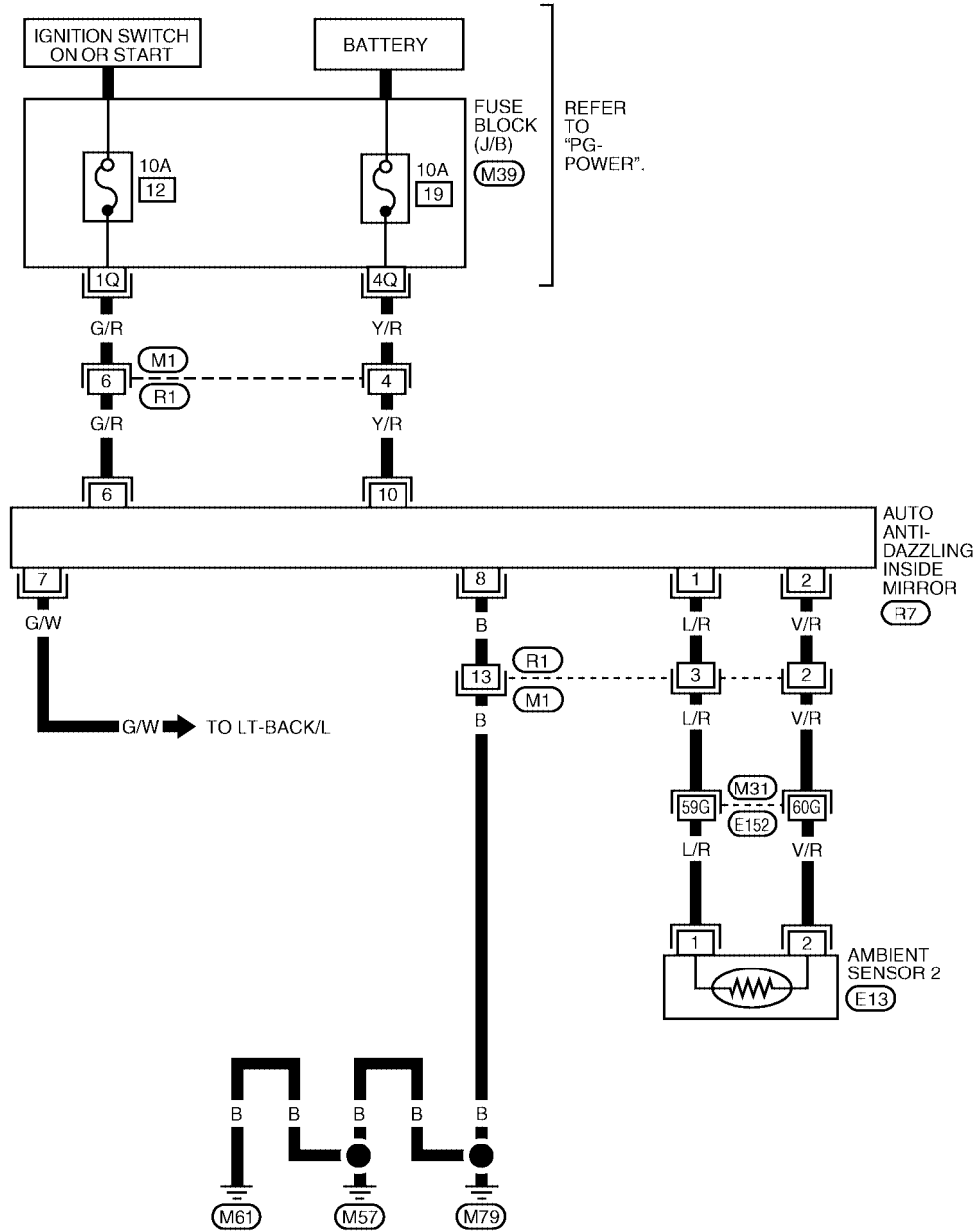

REFER TO THE FOLLOWING.

M31 - SUPER MULTIPLE JUNCTION (SMJ)

WKWA1517E

# COMPASS AND THERMOMETER

EKS0077X

## Trouble Diagnoses

### PRELIMINARY CHECK FOR THERMOMETER

#### 1. COOL DOWN CHECK

1. Turn the ignition switch to the ON position.
2. Cool down the ambient sensor 2 with water or ice.

Does the indicated temperature drop?

Yes >> GO TO 2.

No >> The system is malfunctioning. Check the system following "INSPECTION/COMPASS AND THERMOMETER". Refer to [DI-28, "INSPECTION/COMPASS AND THERMOMETER"](#).

#### 2. WARM UP CHECK

1. Leave the vehicle for 10 minutes.
2. With the ignition switch in the ON position, disconnect and reconnect the ambient sensor 2 connector.

Does the indicated temperature rise?

Yes >> The system is OK.

No >> The system is malfunctioning. Check the system following "INSPECTION/COMPASS AND THERMOMETER". Refer to [DI-28, "INSPECTION/COMPASS AND THERMOMETER"](#).

### INSPECTION/COMPASS AND THERMOMETER

Symptom	Possible causes	Repair order
No display at all	1. 10A fuse 2. Ground circuit 3. Auto anti-dazzling inside mirror	1. Check 10A fuses [No. 12 and 19, located in fuse block (J/B)]. Turn the ignition switch ON and verify that battery positive voltage is at terminals 6 and 10 of auto anti-dazzling inside mirror. 2. Check ground circuit for auto anti-dazzling inside mirror. 3. Replace auto anti-dazzling inside mirror.
Forward direction indication slips off the mark or incorrect.	1. In manual correction mode (Bar and display vanish.) 2. Zone variation change is not done.	1. Drive the vehicle and turn at an angle of 90°. 2. Perform the zone variation change.
Displays wrong temperature when ambient temperature is between -40°C (-40°F) and 55°C (130°F). (See NOTE above.)	1. Check operation 2. Ambient sensor 2 circuit 3. Ambient sensor 2 4. Auto anti-dazzling inside mirror	1. Perform preliminary check shown above. 2. Check harness for open or short between ambient sensor 2 and auto anti-dazzling inside mirror. 3. Replace ambient sensor 2. 4. Replace auto anti-dazzling inside mirror.
Displays SC or OC.	1. Ambient sensor 2 circuit. 2. Ambient sensor 2. 3. Auto anti-dazzling inside mirror.	1. Check harness for open or short between ambient sensor 2 and auto anti-dazzling inside mirror. 2. Replace ambient sensor 2. 3. Replace auto anti-dazzling inside mirror.

# COMPASS AND THERMOMETER

EKS0077Y

## Calibration Procedure for Compass

The difference between magnetic North and geographical North can sometimes be great enough to cause false compass readings. In order for the compass to operate accurately in a particular zone, it must be calibrated using the following procedure.

Zone Variation Chart

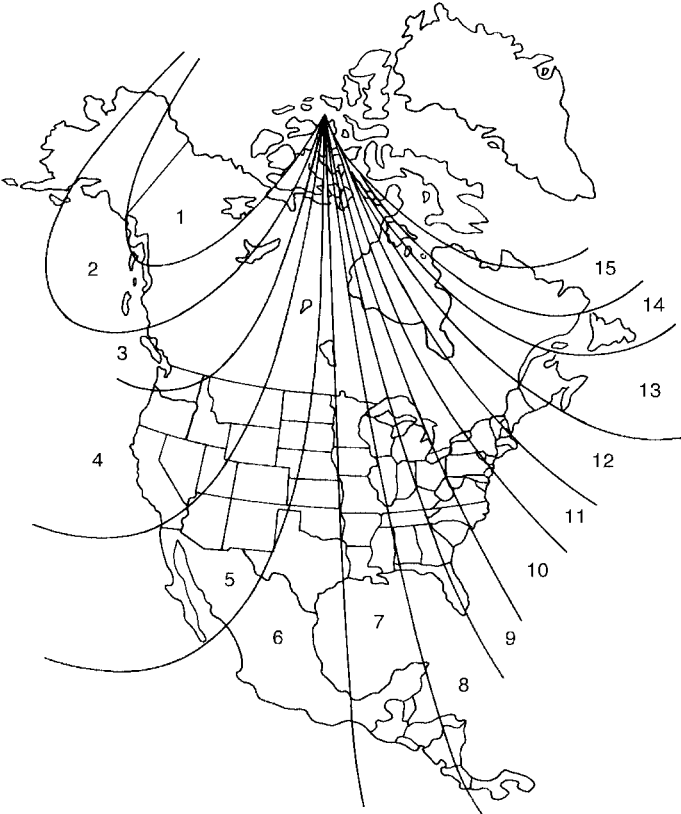

1. Determine your location on the zone map. Record your zone number.

2. Turn the ignition switch to the ON position.

3. Push the "Mode" switch continuously for five seconds until the current zone entry number and the "VAR" icon is displayed.

4. Press the "Mode" switch repeatedly until the desired zone number is displayed.

Once the desired zone number is displayed, stop pressing the "Mode" switch and the display will show compass direction after a few seconds.

NOTE: Use zone number 5 for Hawaii.

WEL859A

## CORRECTION FUNCTIONS OF COMPASS

The direction display is equipped with automatic correction function. If the direction is not shown correctly, carry out initial correction.

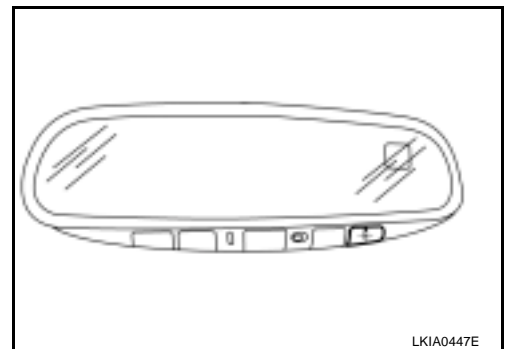

## INITIAL CORRECTION PROCEDURE FOR COMPASS

1. Pushing the Mode switch for about 10 seconds will enter the initial correction mode. The "CAL" icon will illuminate.
2. Turn the vehicle slowly in an open, safe place. The initial correction is completed in one or two turns.

### NOTE:

In places where the terrestrial magnetism is extremely disturbed, the initial correction may start automatically.

# WARNING LAMPS

## WARNING LAMPS

PF2:24814

### Schematic

EKS0077Z

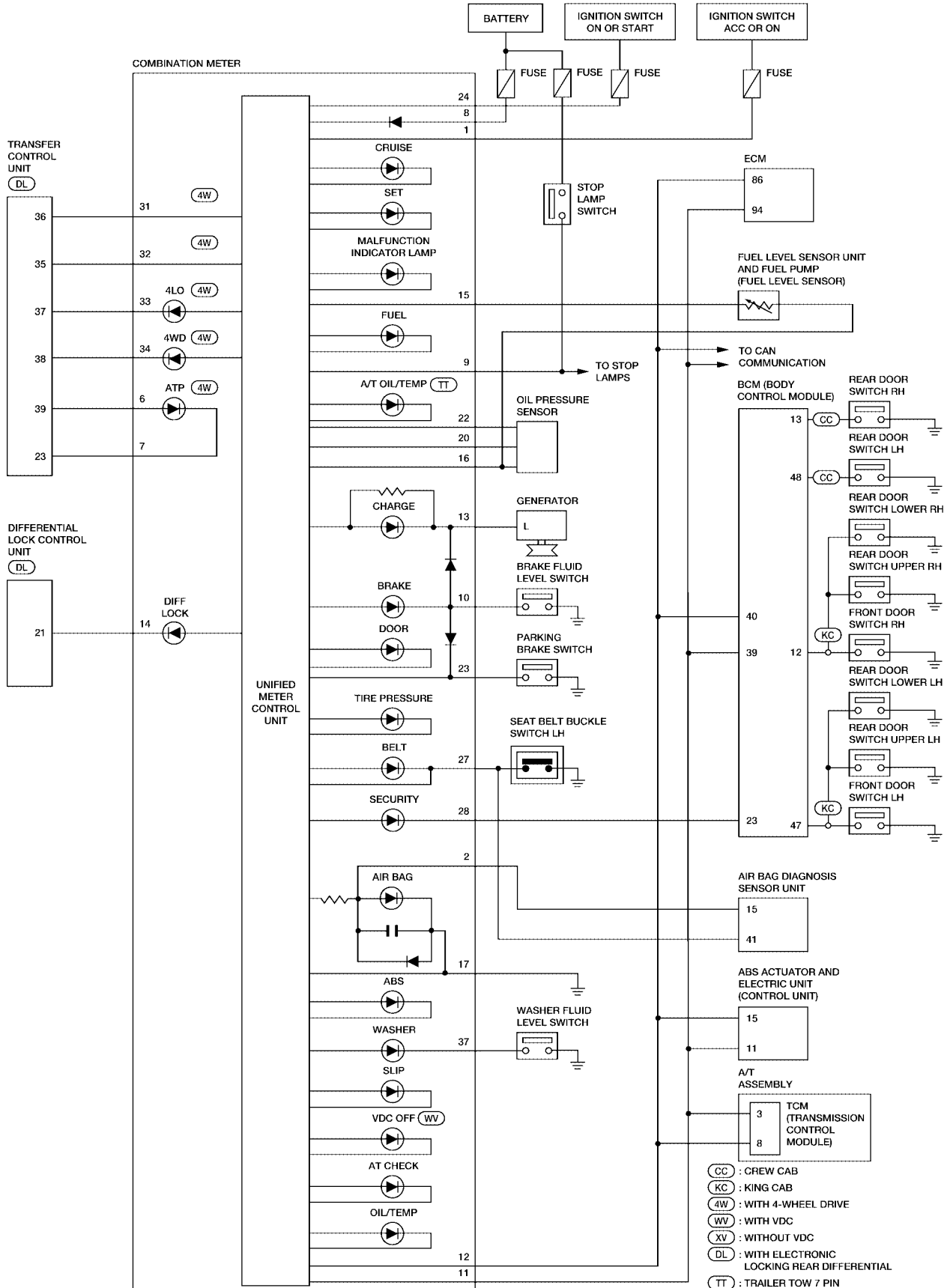

WKWA1547E

# WARNING LAMPS

## Wiring Diagram — WARN —

EKS00780

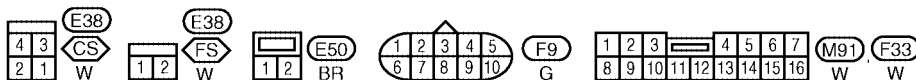
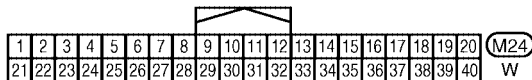
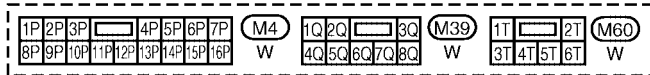
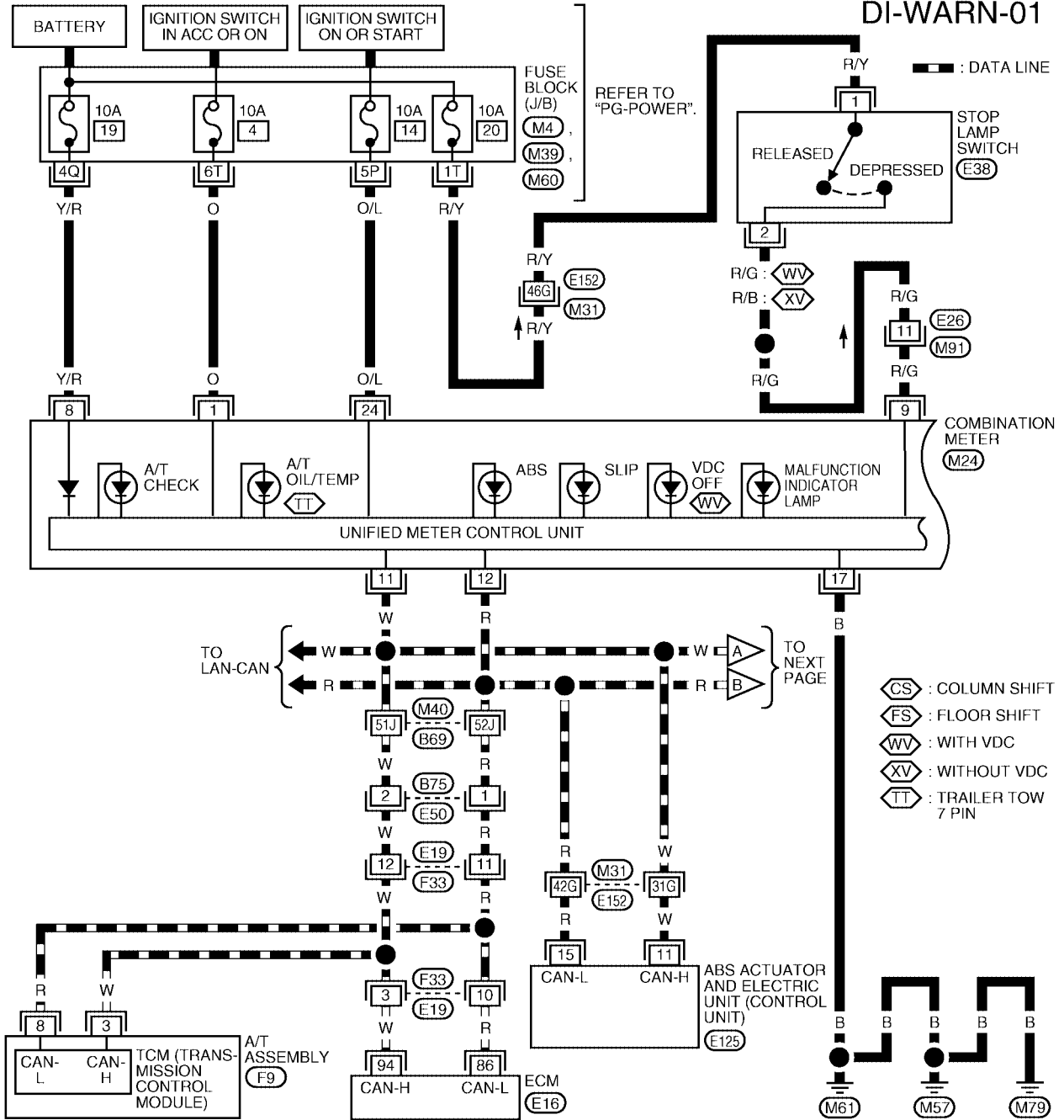

REFER TO THE FOLLOWING.  
 (E16), (E125) - ELECTRICAL UNITS  
 (M31), (M40) - SUPER MULTIPLE JUNCTION (SMJ)

WKWA1548E

# WARNING LAMPS

DI-WARN-02

▬▬▬ : DATA LINE

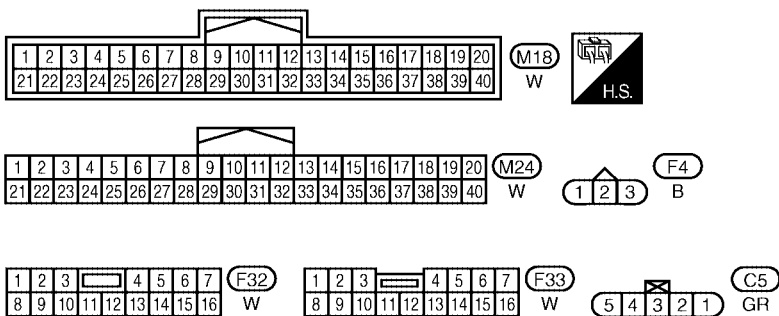
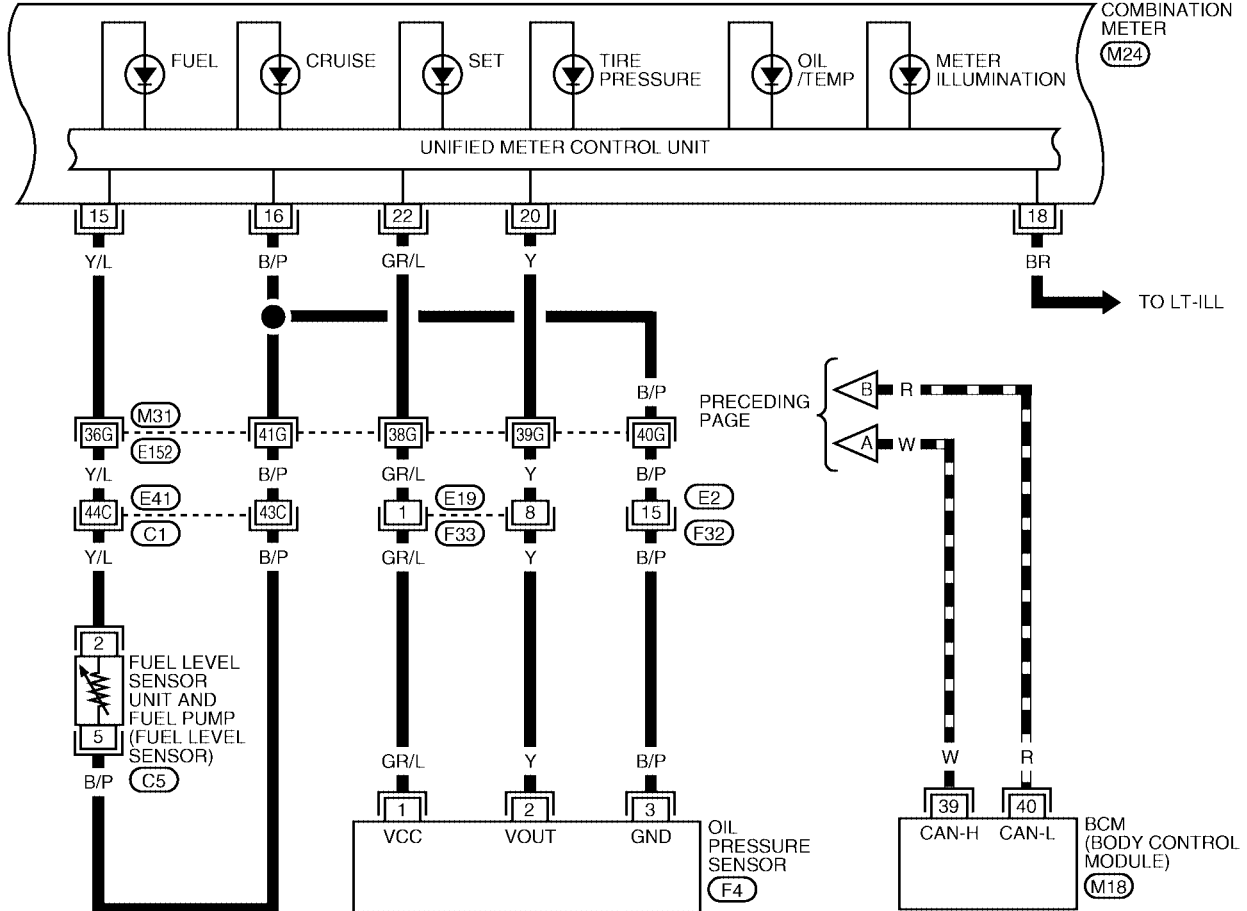

REFER TO THE FOLLOWING  
 (M31), (C1) - SUPER  
 MULTIPLE JUNCTION (SMJ)

WKWA1549E



# WARNING LAMPS

DI-WARN-03

CC : CREW CAB  
KC : KING CAB

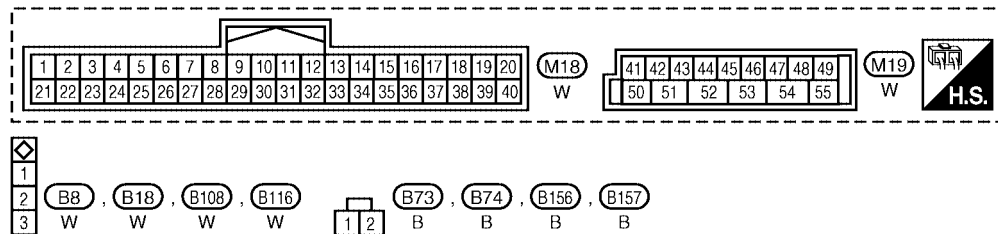
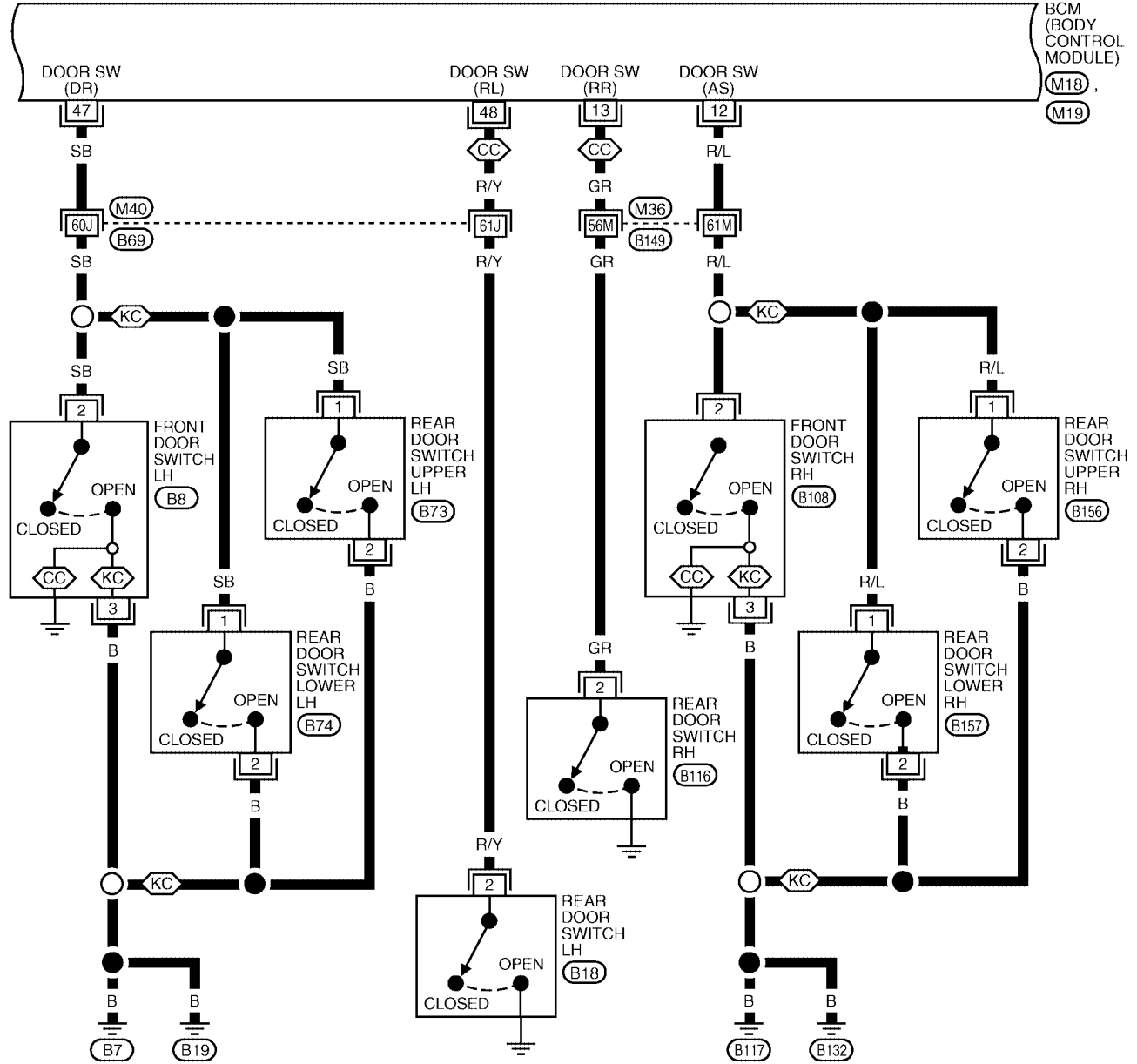

REFER TO THE FOLLOWING.  
M36, M40 - SUPER  
MULTIPLE JUNCTION (SMJ)

WKWA1550E

# WARNING LAMPS

DI-WARN-04

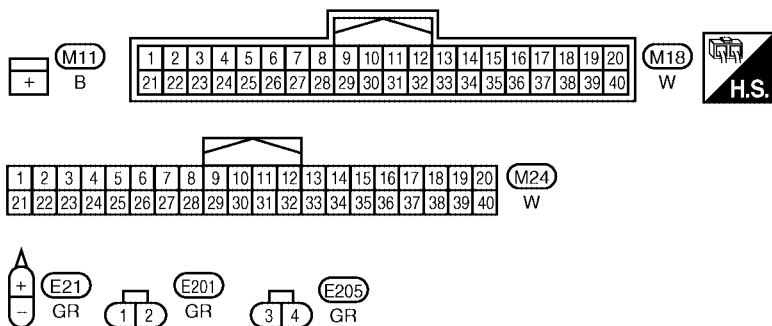
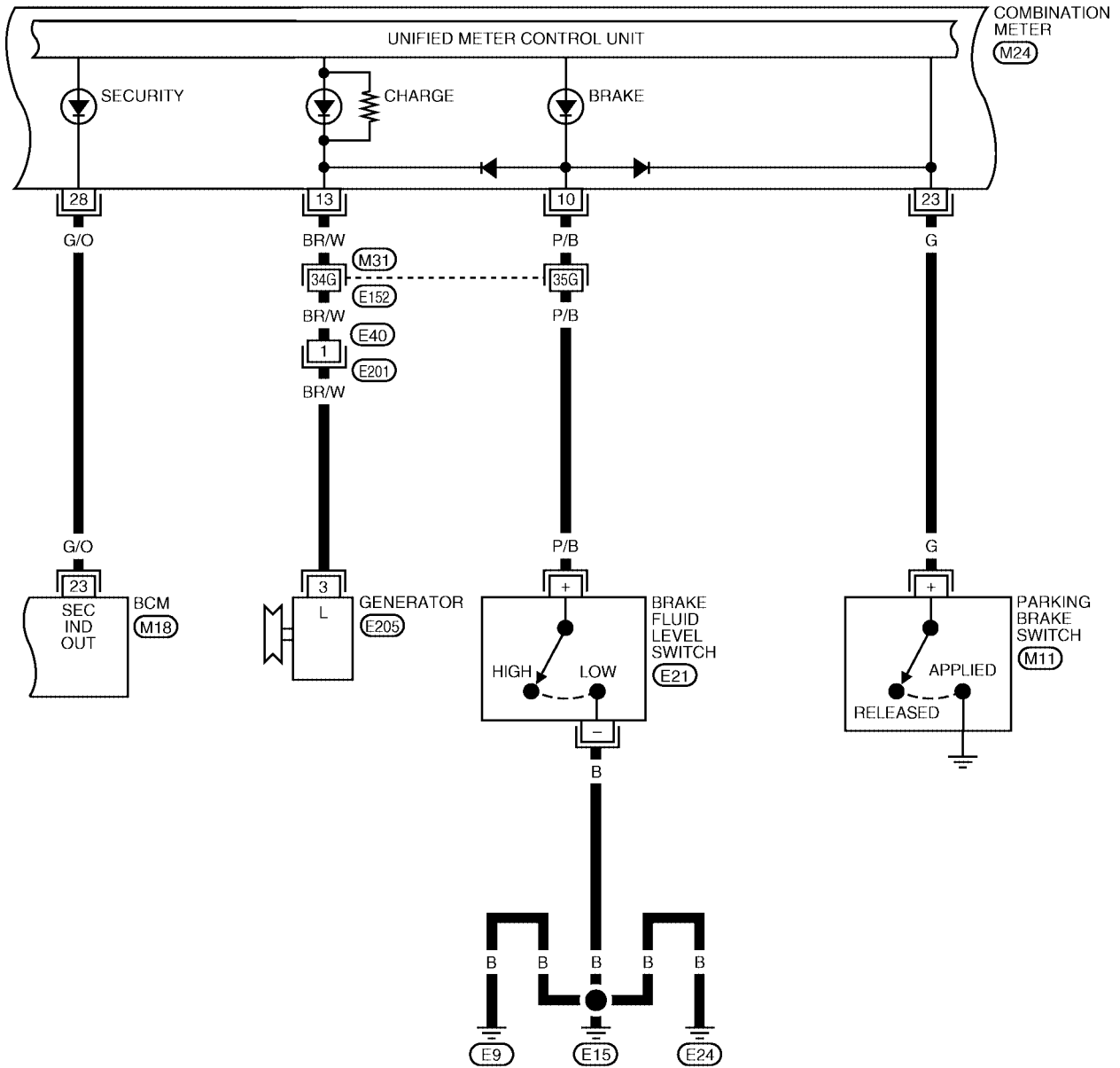

REFER TO THE FOLLOWING.  
 (M31) - SUPER MULTIPLE JUNCTION (SMJ)

WKWA1170E



# WARNING LAMPS

## 4WD Models

## DI-WARN-06

 : WITH ELECTRONIC LOCKING REAR DIFFERENTIAL

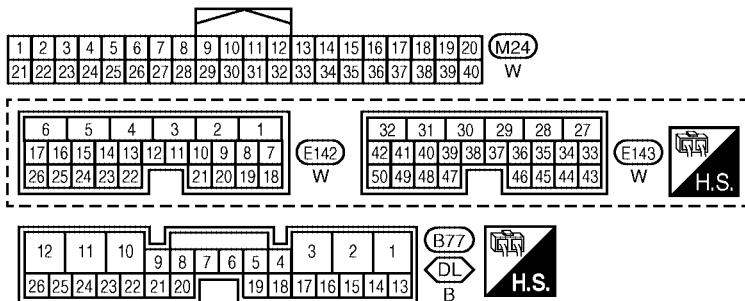
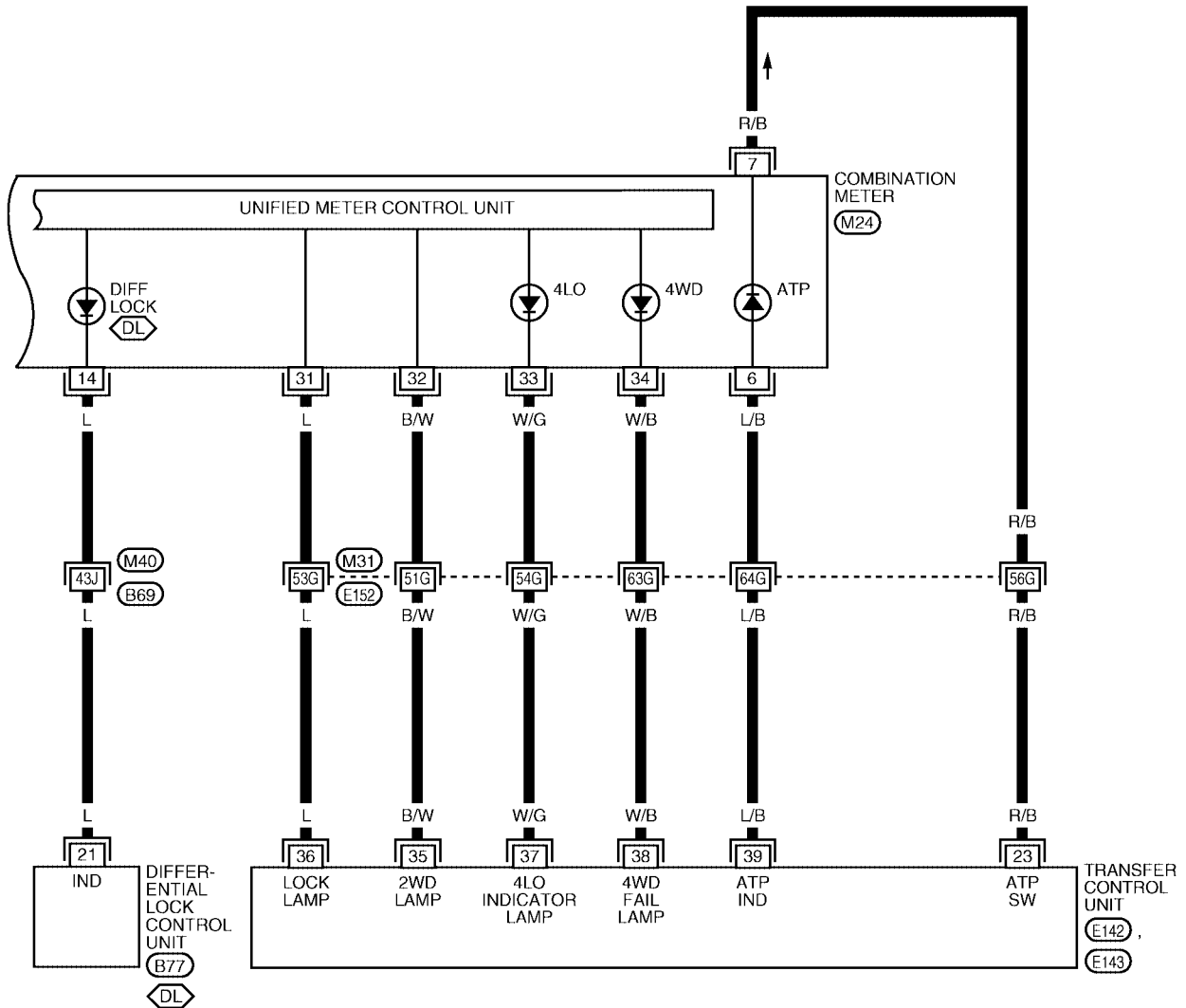

REFER TO THE FOLLOWING.  
 (M31), (M40) - SUPER MULTIPLE JUNCTION (SMJ)

WKWA1551E

# A/T INDICATOR

PF24814

EKS00783

## A/T INDICATOR

### Wiring Diagram — AT/IND —

## DI-AT/IND-01

— : DATA LINE

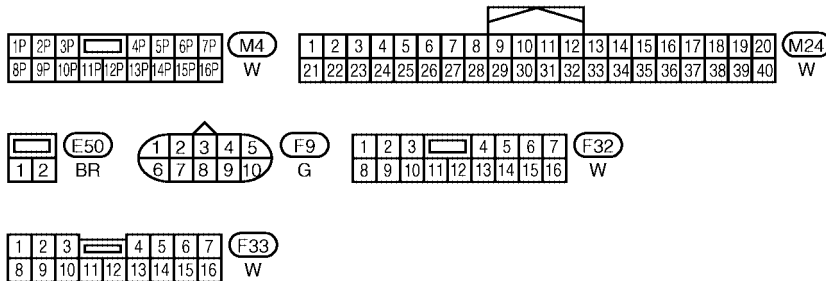
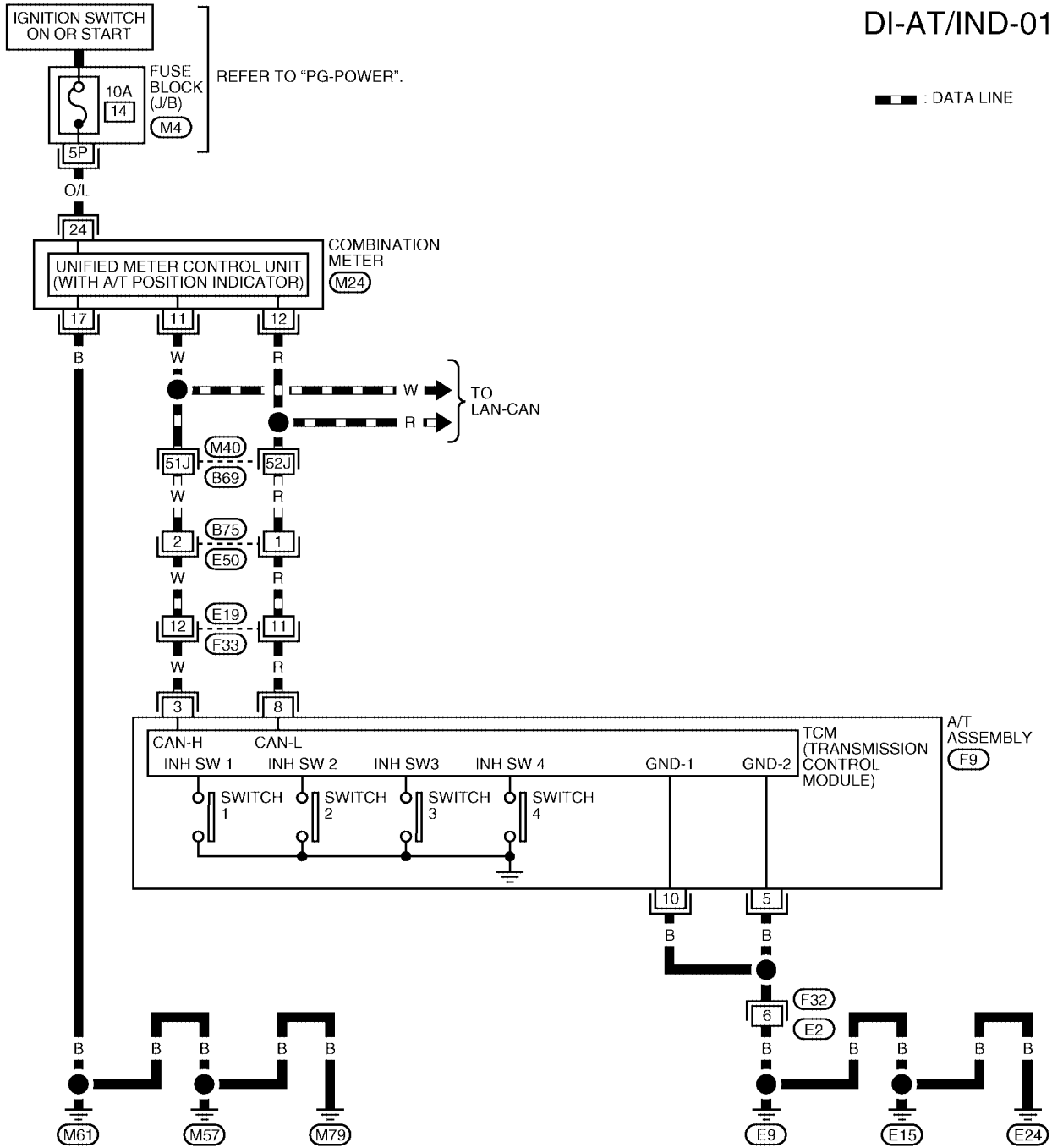

REFER TO THE FOLLOWING.  
**(M40)** - SUPER MULTIPLE JUNCTION (SMJ)

WKWA1566E

# A/T INDICATOR

---

## A/T Indicator Does Not Illuminate

EKS00784

### 1. CHECK SELF-DIAGNOSIS OF COMBINATION METER

---

Perform combination meter self-diagnosis. Refer to [DI-13, "SELF-DIAGNOSIS FUNCTION"](#) .

OK or NG

OK >> GO TO 2.

NG >> Replace combination meter. Refer to [IP-13, "COMBINATION METER"](#) .

### 2. CHECK TCM

---

Perform self-diagnosis of TCM. Refer to [AT-97, "SELF-DIAGNOSTIC RESULT MODE"](#) .

OK or NG

OK >> Replace combination meter. Refer to [IP-13, "COMBINATION METER"](#) .

NG >> Refer to [DI-13, "SELF-DIAGNOSIS FUNCTION"](#) .

# WARNING CHIME

PFP:24814

EKS00785

## WARNING CHIME

### Component Parts and Harness Connector Location

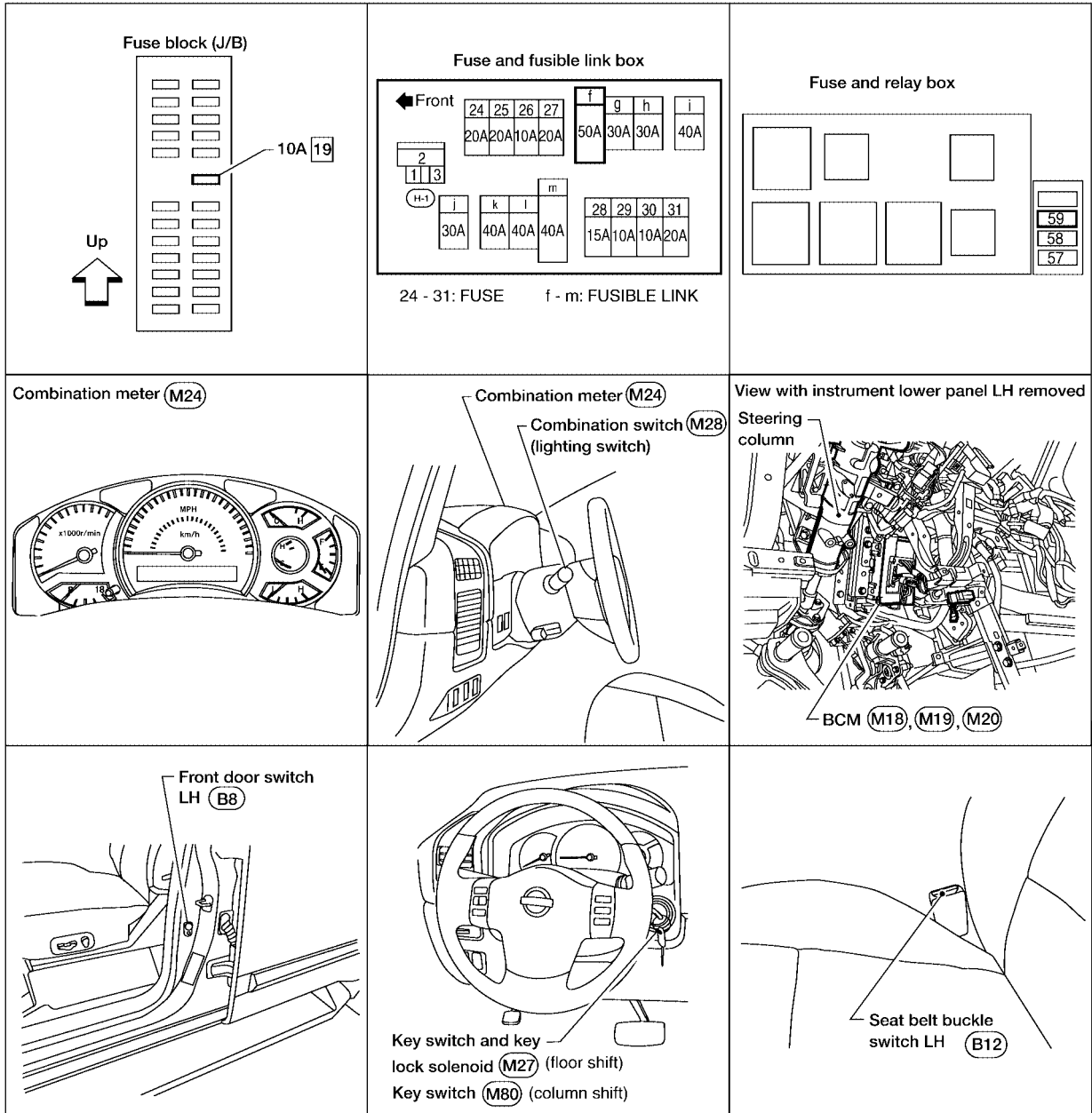

A  
B  
C  
D  
E  
F  
G  
H  
I  
J  
DI  
L  
M

WKIA1829E

# WARNING CHIME

EKS00786

## System Description

### FUNCTION

Power is supplied at all times

- through 50A fusible link (letter **f** , located in the fuse and fusible link box)
- to BCM terminal 70, and
- through 10A fuse [No. 19, located in the fuse block (J/B)]
- to key switch and key lock solenoid terminal 3 (floor shift) or key switch terminal 3 (console shift).

With ignition switch in ON or START position, power is supplied

- through 10A fuse [No. 59, located in the fuse and relay box)
- to BCM terminal 38.

Ground is supplied

- to BCM terminal 67
- through body grounds M57, M61, and M79.

### NOTE:

When ignition key warning chime, light warning chime, and seat belt warning chime are required at the same time, the priorities for each chime are the following.

1. Light warning chime
2. Ignition key warning chime
3. Seat belt warning chime

### IGNITION KEY WARNING CHIME

With the key inserted in the ignition switch, the ignition switch in OFF position, and the driver's door open, the warning chime will sound.

Power is supplied

- through key switch and key lock solenoid terminal 4 (floor shift) or key switch terminal 4 (console shift)
- to BCM terminal 37.

Ground is supplied

- to BCM terminal 47
- through front door switch LH terminal 2
- through body grounds B7 and B19 (king cab) or through front door switch LH case ground (crew cab).

BCM detects key inserted into the ignition switch, and sends key warning signal to combination meter via CAN communication lines. When the combination meter receives key warning signal, it sounds warning chime.

### LIGHT WARNING CHIME

With the key removed from the ignition switch, the driver's door open, and the lighting switch (part of the combination switch) in 1st or 2nd position, the warning chime will sound. [Except when headlamp battery saver control operates (5 minutes after ignition switch is turned to OFF or ACC position) and headlamps do not illuminate.]

Signal is supplied

- from combination switch (lighting switch) terminals 1, 2, 3, 4, 5, 6, 7, 8, 9 and 10
- to BCM terminals 2, 3, 4, 5, 6, 32, 33, 34, 35 and 36.

### NOTE:

BCM detected lighting switch in 1st or 2nd position. Refer to [BCS-3, "COMBINATION SWITCH READING FUNCTION"](#) .

Ground is supplied

- to BCM terminal 47
- through front door switch LH terminal 2.
- through body grounds B7 and B19 (king cab) or through front door switch LH case ground (crew cab).

Front door switch LH is case grounded.

BCM detects headlamps are illuminated, and sends light warning signal to combination meter CAN communication lines. When the combination meter receives light warning signal, it sounds warning chime.



# WARNING CHIME

## SEAT BELT WARNING CHIME

When the ignition switch is turned ON with the seat belt unfastened (seat belt buckle switch LH unfastened), warning chime will sound for approximately 6 seconds.

Ground is supplied

- to combination meter terminal 27
- through seat belt buckle switch LH terminal 1.

Seat belt buckle switch LH terminal 2 is grounded through body grounds B7 and B19.

The combination meter sends seat belt buckle switch LH unfastened signal to BCM via CAN communication line.

BCM receives seat belt buckle switch LH unfastened signal from combination meter via CAN communication line, and sends seat belt warning signal to the combination meter via CAN communication line. When the combination meter receives the seat belt warning signal, it sounds the warning chime. The BCM controls the (6 second) duration of the seat belt warning chime.

## CAN Communication System Description

EKS00787

Refer to [LAN-8, "CAN COMMUNICATION"](#) .

A  
B  
C  
D  
E  
F  
G  
H  
I  
J  
DI  
L  
M

DI

# WARNING CHIME

EKS00788

## Wiring Diagram — CHIME —

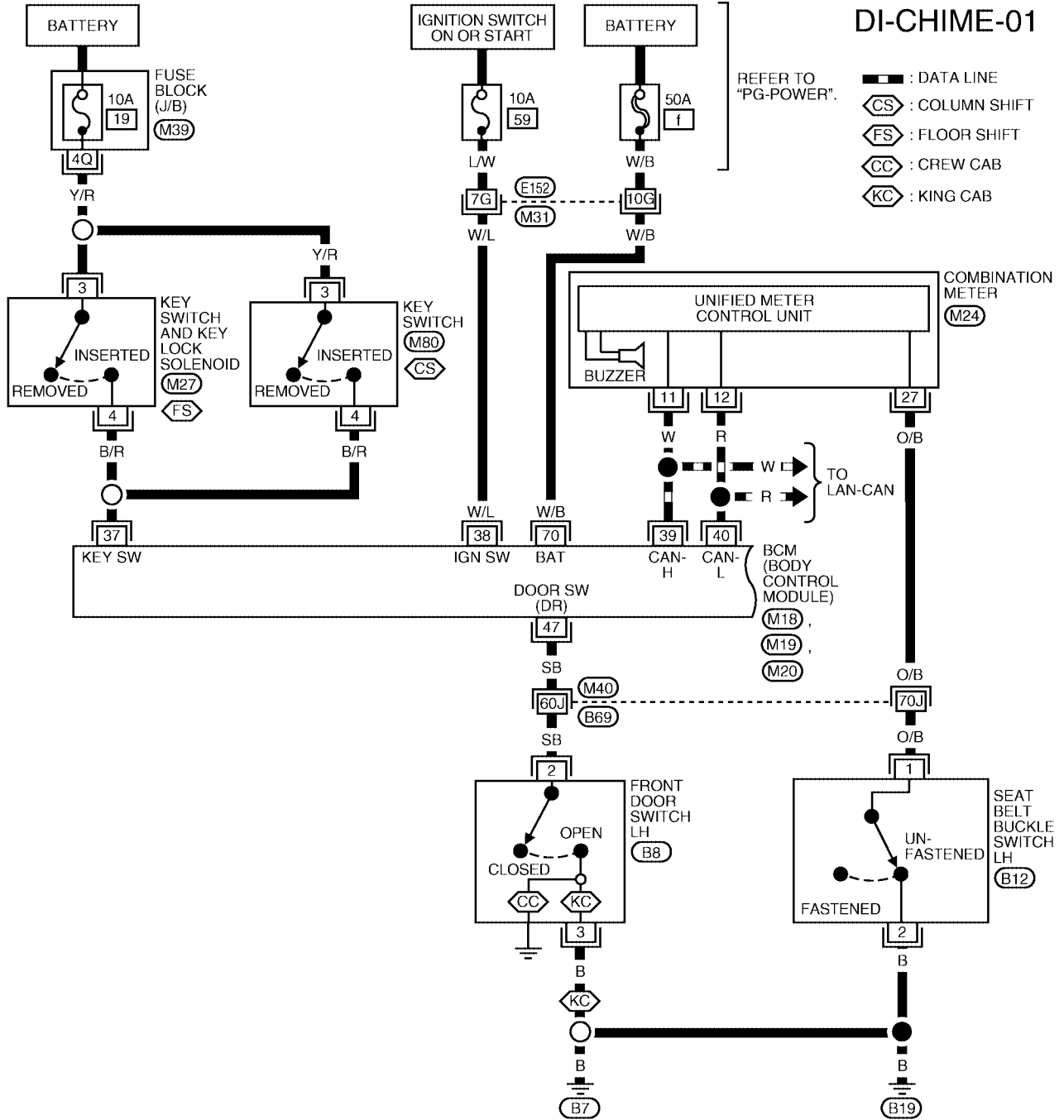

### DI-CHIME-01

REFER TO "PG-POWER".

- : DATA LINE
- CS : COLUMN SHIFT
- FS : FLOOR SHIFT
- CC : CREW CAB
- KC : KING CAB

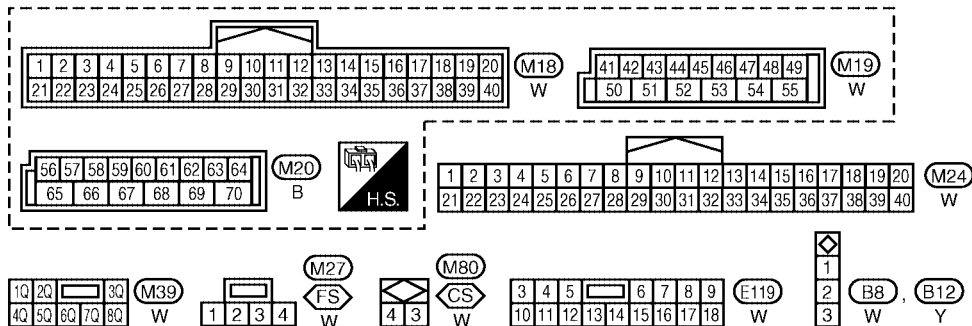

REFER TO THE FOLLOWING.  
M31 , M40 - SUPER  
 MULTIPLE JUNCTION (SMJ)

WKWA1552E

# WARNING CHIME

DI-CHIME-02

A  
B  
C  
D  
E  
F  
G  
H  
I  
J  
DI  
L  
M

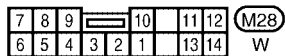
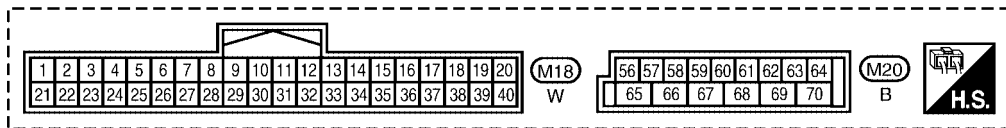
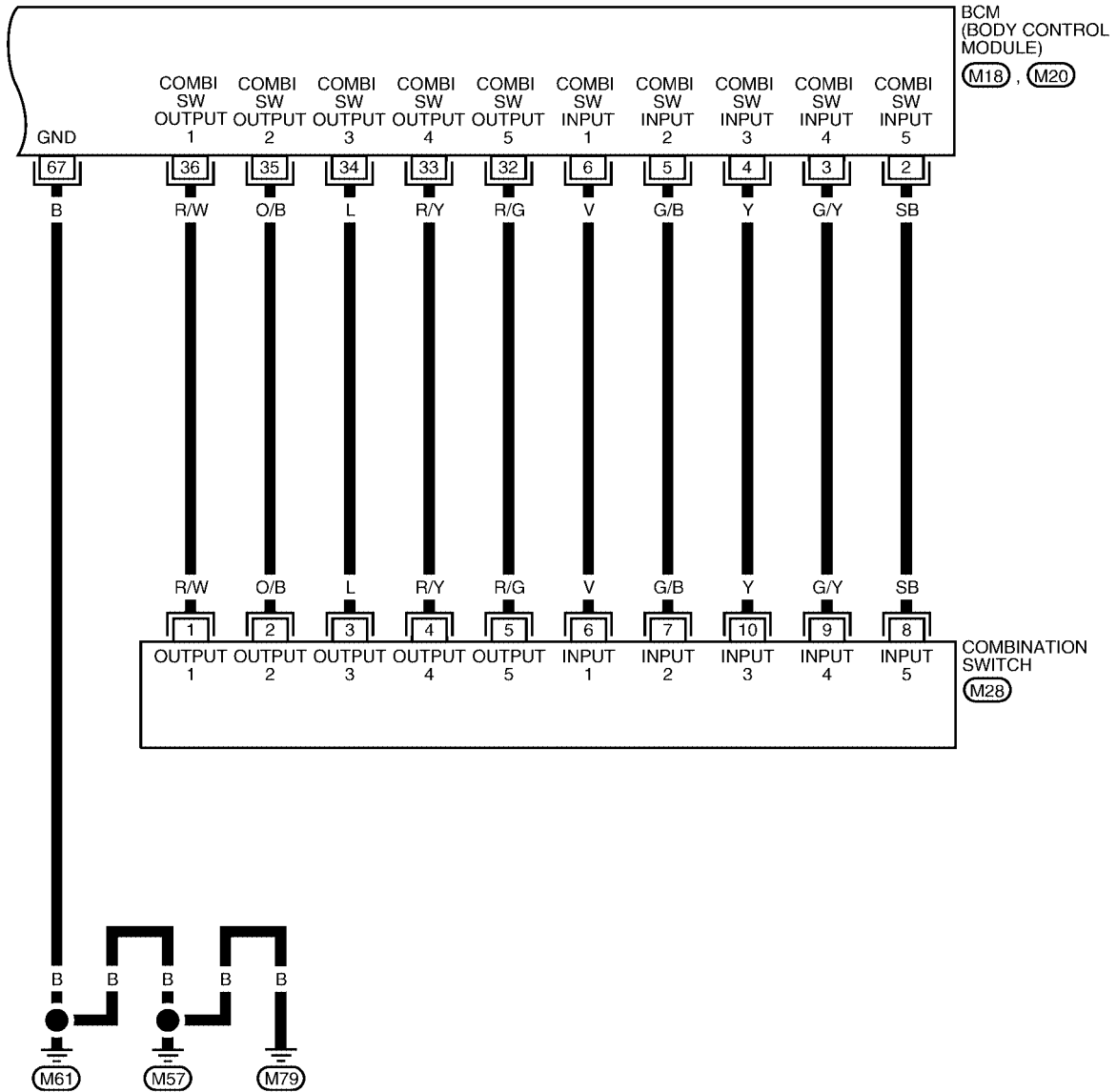



WKWA1131E

# WARNING CHIME

## Terminals and Reference Value for BCM

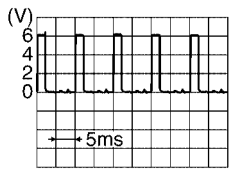
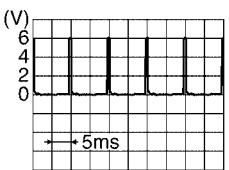
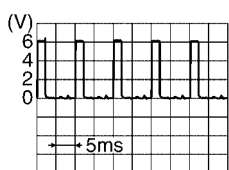
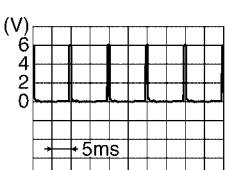
EKS00789

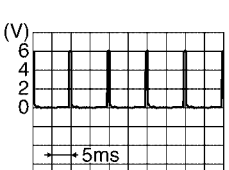
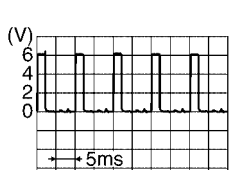
Terminal No.	Wire color	Item	Condition		Reference value (V) (Approx.)
			Ignition switch	Measurement method	
2	SB	Combination switch input 5	ON	<ul style="list-style-type: none"> <li>Light switch and wiper switch OFF</li> <li>Wiper dial position 4</li> </ul>	 <p style="text-align: right;">SKIA5291E</p>
3	G/Y	Combination switch input 4	ON	<ul style="list-style-type: none"> <li>Light switch and wiper switch OFF</li> <li>Wiper dial position 4</li> </ul>	 <p style="text-align: right;">SKIA5292E</p>
4	Y	Combination switch input 3	ON	<ul style="list-style-type: none"> <li>Light switch and wiper switch OFF</li> <li>Wiper dial position 4</li> </ul>	 <p style="text-align: right;">SKIA5291E</p>
5	G/B	Combination switch input 2	ON	<ul style="list-style-type: none"> <li>Light switch and wiper switch OFF</li> <li>Wiper dial position 4</li> </ul>	 <p style="text-align: right;">SKIA5292E</p>
6	V	Combination switch input 1			
32	R/G	Combination switch output 5	ON	<ul style="list-style-type: none"> <li>Light switch and wiper switch OFF</li> <li>Wiper dial position 4</li> </ul>	 <p style="text-align: right;">SKIA5291E</p>
33	R/Y	Combination switch output 4	ON	<ul style="list-style-type: none"> <li>Light switch and wiper switch OFF</li> <li>Wiper dial position 4</li> </ul>	 <p style="text-align: right;">SKIA5292E</p>
34	L	Combination switch output 3	ON	<ul style="list-style-type: none"> <li>Light switch and wiper switch OFF</li> <li>Wiper dial position 4</li> </ul>	 <p style="text-align: right;">SKIA5291E</p>

# WARNING CHIME

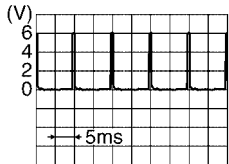
Terminal No.	Wire color	Item	Condition		Reference value (V) (Approx.)
			Ignition switch	Measurement method	
35	O/B	Combination switch output 2	ON	<ul style="list-style-type: none"> <li>● Light switch and wiper switch OFF</li> <li>● Wiper dial position 4</li> </ul>	
36	R/W	Combination switch output 1			
37	B/R	Key switch signal	OFF	Key is removed	0
				Key is inserted	Battery voltage
38	W/L	Ignition switch ON or START	ON	—	Battery voltage
39	W	CAN-H	—	—	—
40	R	CAN-L	—	—	—
47	SB	Front door switch LH signal	OFF	ON (open)	0
				OFF (closed)	5
67	B	Ground	ON	—	0
70	W/B	Battery power supply	OFF	—	Battery voltage

## Terminals and Reference Value for Combination Meter

EKS0078A

Terminal No.	Wire color	Item	Condition		Reference value (V) (Approx.)
			Ignition switch	Measurement method	
11	W	CAN-H	—	—	—
12	R	CAN-L	—	—	—
27	O/B	Seat belt buckle switch LH	ON	Unfastened (ON)	0
				Fastened (OFF)	Battery voltage

## How to Proceed With Trouble Diagnosis

EKS0078B

1. Confirm the symptom or customer complaint.
2. Understand operation description and function description. Refer to [DI-40, "System Description"](#) .
3. Perform the preliminary check. Refer to [DI-45, "Preliminary Check"](#) .
4. Check symptom and repair or replace the cause of malfunction.
5. Does the warning chime operate properly? If so, go to 6. If not, go to 3.
6. Inspection End.

## Preliminary Check

EKS0078C

### INSPECTION FOR POWER SUPPLY AND GROUND CIRCUIT

#### 1. CHECK FUSE AND FUSIBLE LINK

Check for blown BCM fuse or fusible link.

Unit	Power source	Fuse or fusible link No.
BCM	Battery	f
	Ignition switch ON or START	59

Refer to [DI-42, "Wiring Diagram — CHIME —"](#) .

OK or NG

OK >> GO TO 2.

NG >> If fuse is blown, be sure to eliminate cause of malfunction before installing new fuse. Refer to [PG-4, "POWER SUPPLY ROUTING CIRCUIT"](#) .

# WARNING CHIME

## 2. CHECK POWER SUPPLY CIRCUIT

1. Disconnect BCM connector.
2. Check voltage between BCM harness connector terminals and ground.

Terminals		Ignition switch position	
(+)		OFF	ON
Connector	Terminal (Wire color)	(-)	
M20	70 (W/B)	Battery voltage	Battery voltage
M18	38 (W/L)	0V	Battery voltage

OK or NG

OK >> GO TO 3.

NG >> Check harness for open between BCM and fuse.

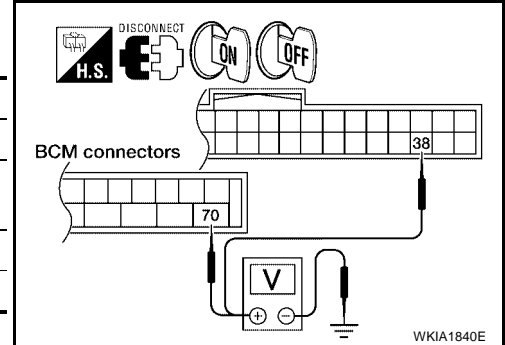

## 3. CHECK GROUND CIRCUIT

1. Turn ignition switch OFF.
2. Check continuity between BCM harness connector M20 terminal 67 (B) and ground.

**Continuity should exist.**

OK or NG

OK >> Inspection End.

NG >> Repair harness or connector.

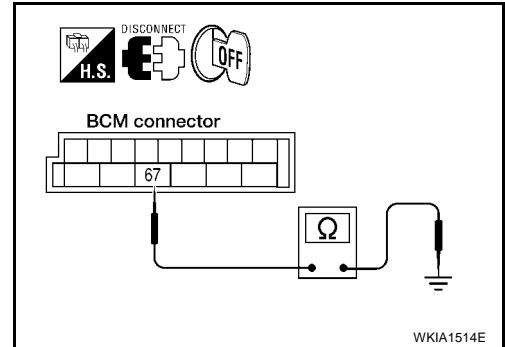

# WARNING CHIME

EKS0078D

## CONSULT-II Function

CONSULT-II can display each diagnostic item using the diagnostic test modes shown following.

### DIAGNOSTIC ITEMS DESCRIPTION

BCM diagnosis position	Diagnosis mode	Description
BUZZER	Data monitor	The input data to the BCM is displayed in real time.
	Active test	Operation of electrical loads can be checked by sending driving signal to them.
BCM	Self-diagnostic results	BCM performs self-diagnosis of CAN communication.

### CONSULT-II BASIC OPERATION PROCEDURE

#### CAUTION:

If CONSULT-II is used with no connection of CONSULT-II CONVERTER, malfunctions might be detected in self-diagnosis depending on control unit which carries out CAN communication.

1. With the ignition switch OFF, connect "CONSULT-II" and "CONSULT-II CONVERTER" to the data link connector, and turn ignition switch ON.

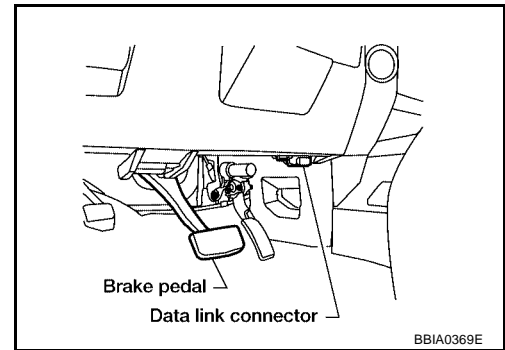

2. Touch "START (NISSAN BASED VHCL)".

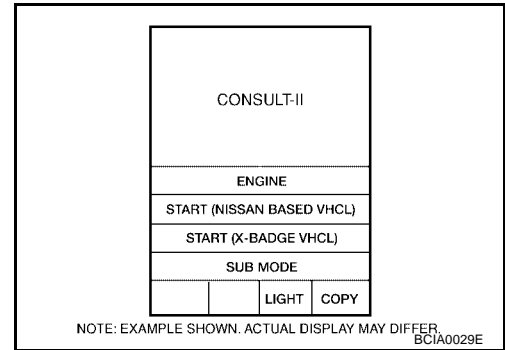

3. Touch "BCM" on "SELECT SYSTEM" screen. If "BCM" is not indicated, go to [BCS-11. "CONSULT-II INSPECTION PROCEDURE"](#).

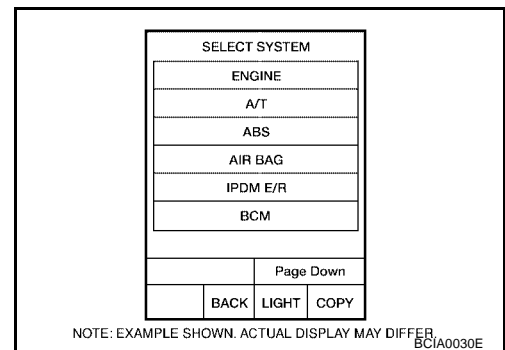

# WARNING CHIME

4. Touch "BUZZER" in "BCM".

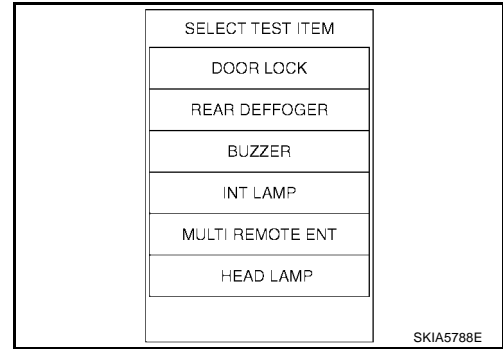

5. Select "DATA MONITOR" or "SELF-DIAG RESULTS".

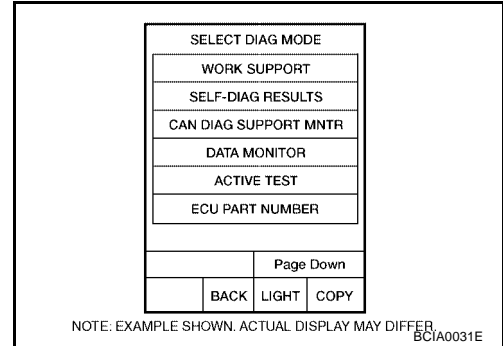

## DATA MONITOR

### Operation Procedure

1. Touch "BUZZER" on "SELECT TEST ITEM" screen.
2. Touch "DATA MONITOR" on "SELECT DIAG MODE" screen.
3. Touch "ALL SIGNALS" or "SELECTION FROM MENU" on "DATA MONITOR" screen.

ALL SIGNALS	Monitors main items.
SELECTION FROM MENU	Selects and monitors items.

4. If "SELECTION FROM MENU" is selected, touch the item you desire to monitor. If "ALL SIGNALS" is selected, all control items are monitored.
5. Touch "START".
6. During monitoring, touching "RECORD" can start recording the monitored item status.

### Display Item List

Monitored item	Description
IGN ON SW	Indicates [ON/OFF] condition of ignition switch.
KEY ON SW	Indicates [ON/OFF] condition of key switch.
DOOR SW-DR	Indicates [ON/OFF] condition of front door switch (driver side).
TAIL LAMP SW	Indicates [ON/OFF] condition of lighting switch.
BUCKLE SW	Indicates [ON/OFF] condition of seat belt buckle switch LH.

## ACTIVE TEST

### Operation Procedure

1. Touch "BUZZER" on "SELECT TEST ITEM" screen.
2. Touch "ACTIVE TEST" on "SELECT DIAG MODE" screen.
3. Touch the item to be tested, and check the operation.
4. During the operation check, touching "OFF" deactivates the operation.



# WARNING CHIME

## Display Item List

Test item	Malfunction is detected when...
LIGHT WARN ALM	This test is able to check light warning chime operation. Light warning chime sounds for 2 seconds after touching "ON" on CONSULT-II screen.
IGN KEY WARN ALM	This test is able to check key warning chime operation. Key warning chime sounds for 2 seconds after touching "ON" on CONSULT-II screen.
SEAT BELT WARN TEST	This test is able to check seat belt warning chime operation. Seat belt warning chime sounds for 2 seconds after touching "ON" on CONSULT-II screen.

## SELF-DIAGNOSTIC RESULTS

### Operation Procedure

1. Touch "BCM" on "SELECT TEST ITEM" screen.
2. Touch "SELF-DIAG RESULTS" on "SELECT DIAG MODE" screen.
3. Self-diagnostic results are displayed.

### Display Item List

Monitored Item	CONSULT-II display	Description
CAN communication	CAN communication [U1000]	Malfunction is detected in CAN communication.

### NOTE:

If "CAN communication [U1000]" is displayed, after printing the monitor item, go to "CAN System". Refer to [LAN-8, "CAN COMMUNICATION"](#).

## All Warning Chimes Do Not Operate

EKS0078E

### 1. CHECK BCM CHIME OPERATION

Select "BUZZER" on CONSULT-II, and perform "LIGHT WARN ALM", "IGN KEY WARN ALM", OR "SEAT BELT WARN" active test.

Does chime sound?

- YES >> Replace the BCM. Refer to [BCS-25, "Removal and Installation of BCM"](#).
- NO >> Replace the combination meter. Refer to [DI-25, "Removal and Installation of Combination Meter"](#).

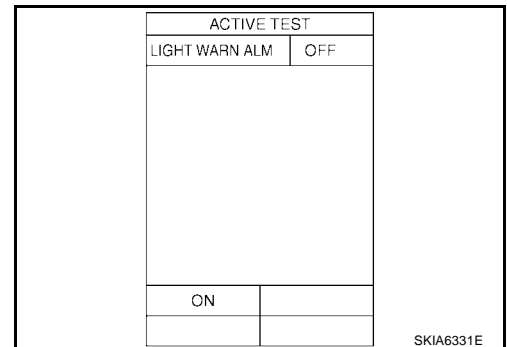

# WARNING CHIME

## Key Warning Chime and Light Warning Chime Do Not Operate (Seat Belt Warning Chime Does Operate)

EKS0078F

### 1. CHECK BCM INPUT SIGNAL

#### Ⓟ With CONSULT-II

1. Select "BCM" on CONSULT-II.
2. With "DATA MONITOR" of "BUZZER", confirm "DOOR SW-DR" changes with the status of front door LH.

**When front door LH is opened : DOOR SW-DR ON**

**When front door LH is closed : DOOR SW-DR OFF**

DATA MONITOR	
MONITOR	NO DTC
IGN ON SW	ON
KEY ON SW	ON
DOOR SW-DR	OFF

LKIA0335E

#### ⊗ Without CONSULT-II

Check voltage between BCM harness connector M19 terminal 47 (SB) and ground.

**When front door LH is opened : Approx. 0V**

**When front door LH is closed : Approx. 5V**

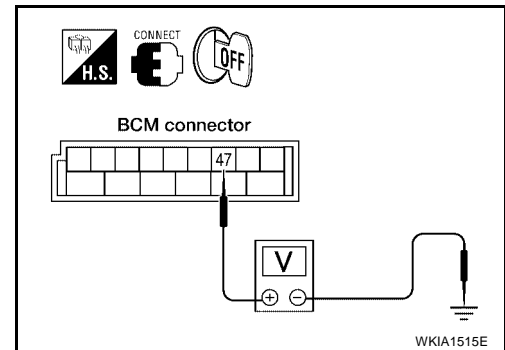

#### OK or NG

- OK >> Replace the BCM. Refer to [BCS-25. "Removal and Installation of BCM"](#).
- NG >> GO TO 2.

### 2. CHECK FRONT DOOR SWITCH LH CIRCUIT

1. Turn ignition switch OFF.
2. Disconnect BCM connector and front door switch LH connector.
3. Check continuity between BCM harness connector M19 terminal 47 (SB) and front door switch LH harness connector B8 terminal 2 (SB).

**Continuity should exist.**

4. Check continuity between BCM harness connector M19 terminal 47 (SB) and ground.

**Continuity should not exist.**

#### OK or NG

- OK >> GO TO 3.
- NG >> Repair harness or connector.

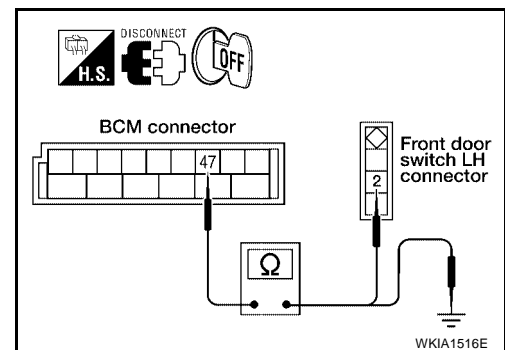

# WARNING CHIME

## 3. CHECK FRONT DOOR SWITCH LH

### CREW CAB MODELS

Check continuity between front door switch LH connector B8 terminal 2 and exposed metal of switch while pushing and releasing switch.

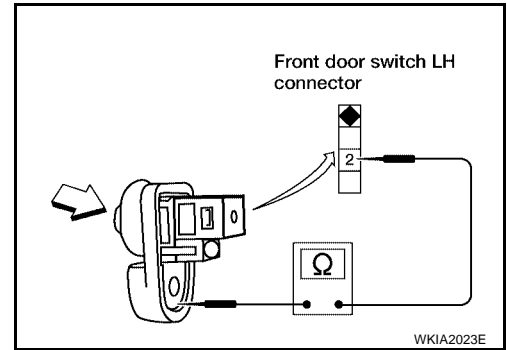

### KING CAB MODELS

Check continuity between front door switch LH connector B8 terminal 2 and terminal 3 of switch while pushing and releasing switch.

**When front door switch LH is released** : Continuity should exist.

**When front door switch LH is pushed** : Continuity should not exist.

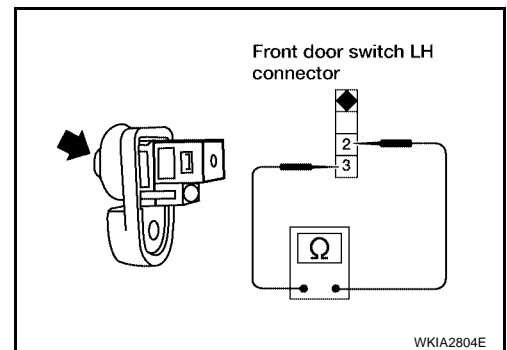

OK or NG

OK >> Replace the BCM. Refer to [BCS-25, "Removal and Installation of BCM"](#) .

NG >> Replace the front door switch LH.

## Key Warning Chime Does Not Operate

### 1. CHECK FUSE

Check if the key switch fuse [No. 19, located in the fuse block (J/B)] is blown. Refer to [DI-42, "Wiring Diagram — CHIME —"](#) .

Is the fuse blown?

YES >> Replace the fuse. Be sure to repair the cause of malfunction before installing new fuse.

NO >> GO TO 2.

### 2. CHECK WARNING CHIME OPERATION

With key removed from the ignition and the front door LH open, turn the lighting switch to 1st or 2nd position.

Does warning chime sound?

YES >> GO TO 3.

NO >> Go to [DI-49, "All Warning Chimes Do Not Operate"](#) or [DI-50, "Key Warning Chime and Light Warning Chime Do Not Operate \(Seat Belt Warning Chime Does Operate\)"](#) .

# WARNING CHIME

## 3. CHECK BCM INPUT SIGNAL

### With CONSULT-II

With "DATA MONITOR" of "BUZZER", confirm "KEY ON SW" changes when the key is inserted/removed from the ignition key cylinder.

**When key is inserted in ignition key cylinder : KEY ON SW ON**

**When key is removed from ignition key cylinder : KEY ON SW OFF**

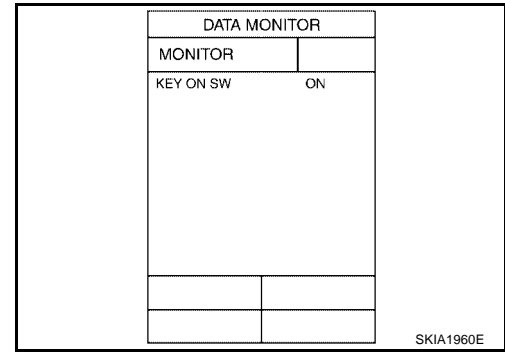

### Without CONSULT-II

Check voltage between BCM harness connector M18 terminal 37 (B/R) and ground.

**When key is inserted in ignition key cylinder : Approx. 12V**

**When key is removed from ignition key cylinder : Approx. 0V**

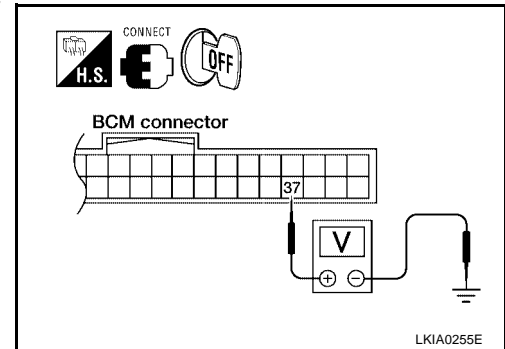

### OK or NG

OK >> Replace the BCM. Refer to [BCS-25, "Removal and Installation of BCM"](#).

NG >> GO TO 4.

## 4. CHECK KEY SWITCH

1. Turn ignition switch OFF.
2. Disconnect key switch and key lock solenoid connector (floor shift) or key switch connector (column shift).
3. Check continuity between key switch and key lock solenoid harness connector M27 (floor shift) or key switch harness connector M80 (column shift) terminals 3 and 4.

**When key is inserted in ignition key cylinder : Continuity should exist**

**When key is removed from ignition key cylinder : Continuity should not exist**

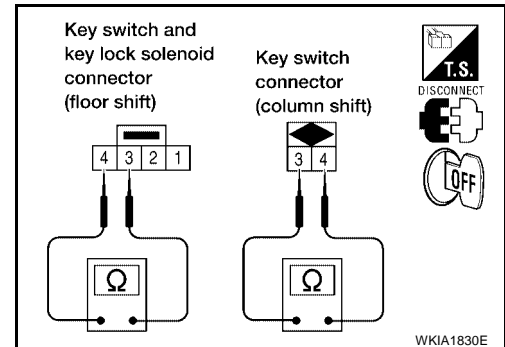

### OK or NG

OK >> GO TO 5.

NG >> Replace the key switch and key lock solenoid connector (floor shift) or key switch connector (column shift).

# WARNING CHIME

## 5. CHECK KEY SWITCH CIRCUIT

1. Disconnect BCM connector.
2. Check continuity between BCM harness connector M18 terminal 37 (B/R) and key switch and key lock solenoid harness connector M80 (floor shift) or key switch harness connector M27 (column shift) terminal 4 (B/R).

Continuity should exist.

3. Check continuity between BCM harness connector M18 terminal 37 (B/R) and ground.

Continuity should not exist.

OK or NG

- OK >> GO TO 6.
- NG >> Repair harness or connector.

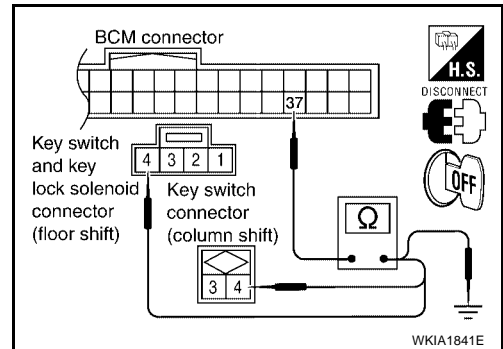

## 6. CHECK KEY SWITCH POWER SUPPLY CIRCUIT

Check voltage between key switch and key lock solenoid harness connector M80 (floor shift) or key switch harness connector M27 (column shift) terminal 3 (Y/R) and ground.

Battery voltage should exist.

OK or NG

- OK >> Replace the BCM. Refer to [BCS-25, "Removal and Installation of BCM"](#).
- NG >> Check harness for open or short between fuse and key switch and key lock solenoid connector (floor shift) or key switch connector (column shift).

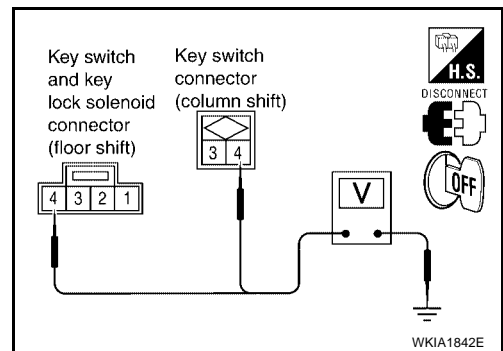

## Light Warning Chime Does Not Operate

### 1. CHECK WARNING CHIME OPERATION

Check key warning chime and seat belt warning chime functions.

Do key warning chime and seat belt warning chime sound?

- YES >> GO TO 2.
- NO >> Go to [DI-49, "All Warning Chimes Do Not Operate"](#).

### 2. CHECK BCM INPUT SIGNAL

**With CONSULT-II**

1. Select "BCM".
2. With "DATA MONITOR" of "BUZZER", confirm "TAIL LAMP SW" status changes when the lighting switch is moved from ON (1st position) to OFF.

Lighting switch ON (1st position) : TAIL LAMP SW ON  
Lighting switch OFF : TAIL LAMP SW OFF

**Without CONSULT-II**

Check combination switch. Refer to [LT-97, "Combination Switch Reading Function"](#).

OK or NG

- OK >> Replace the BCM. Refer to [BCS-25, "Removal and Installation of BCM"](#).
- NG >> Check lighting switch. Refer to [LT-97, "Combination Switch Reading Function"](#).

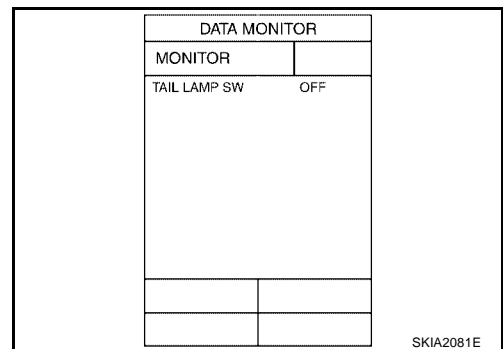

# WARNING CHIME

EKS0078I

## Seat Belt Warning Chime Does Not Operate

### 1. CHECK WARNING CHIME OPERATION

1. With key removed from the ignition and the front door LH open, turn the lighting switch to 1st or 2nd position.
2. Return lighting switch to OFF position, and insert key into ignition.

Does warning chime sound for both steps?

- YES >> GO TO 2.  
NO >> Go to [DI-49, "All Warning Chimes Do Not Operate"](#) .

### 2. CHECK SEAT BELT WARNING LAMP OPERATION

Turn ignition switch ON. Buckle and unbuckle the driver seat belt while watching seat belt warning lamp.

- When seat belt is fastened : Warning lamp OFF**  
**When seat belt is unfastened : Warning lamp ON**

OK or NG

- OK >> Replace the BCM. Refer to [BCS-25, "Removal and Installation of BCM"](#) .  
NG >> GO TO 3.

### 3. CHECK COMBINATION METER INPUT SIGNAL

1. Turn ignition switch ON.
2. Check voltage between combination meter harness connector M24 terminal 27 (O/B) and ground.

- When seat belt is fastened : Approx. 12V**  
**When seat belt is unfastened : Approx. 0V**

OK or NG

- OK >> Replace the combination meter. Refer to [DI-25, "Removal and Installation of Combination Meter"](#)  
NG >> GO TO 4.

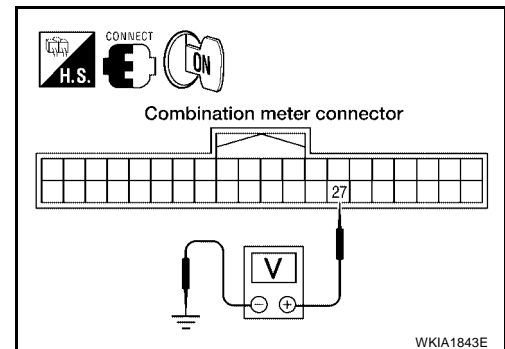

WKIA1843E

### 4. CHECK SEAT BELT BUCKLE SWITCH

1. Turn ignition switch OFF.
2. Disconnect seat belt buckle switch LH connector.
3. Check continuity between seat belt buckle switch LH harness connector B12 terminals 1 and 2.

- When seat belt is fastened : Continuity should exist**  
**When seat belt is unfastened : Continuity should not exist**

OK or NG

- OK >> GO TO 5.  
NG >> Replace the seat belt buckle switch LH.

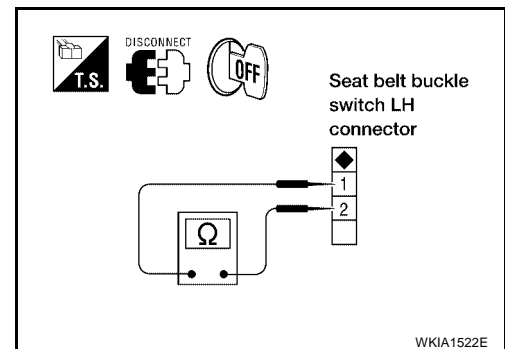

WKIA1522E

# WARNING CHIME

## 5. CHECK SEAT BELT BUCKLE SWITCH CIRCUIT

1. Disconnect combination meter connector.
2. Check continuity between combination meter harness connector M24 terminal 27 (O/B) and seat belt buckle switch LH harness connector B12 terminal 1 (O/B).

**Continuity should exist.**

3. Check continuity between combination meter harness connector M24 terminal 27 (O/B) and ground.

**Continuity should not exist.**

OK or NG

OK >> GO TO 6.

NG >> Repair harness or connector.

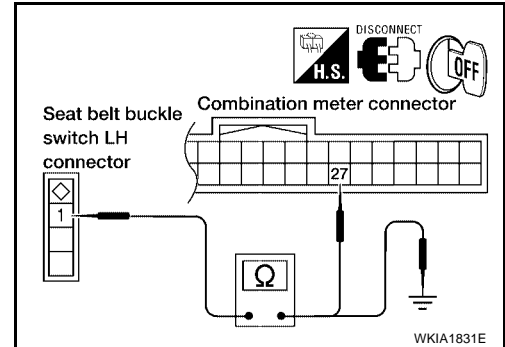

## 6. CHECK SEAT BELT BUCKLE SWITCH GROUND CIRCUIT

Check continuity between seat belt buckle switch LH harness connector B12 terminal 2 (B) and ground.

**Continuity should exist.**

OK or NG

OK >> Replace combination meter. Refer to [IP-13, "COMBINATION METER"](#).

NG >> Repair harness or connector.

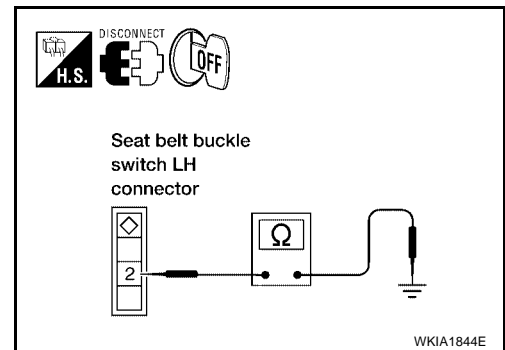

A  
B  
C  
D  
E  
F  
G  
H  
I  
J  
DI  
L  
M

# REAR SONAR SYSTEM

PF2:28532

EKS0078J

## REAR SONAR SYSTEM

### Component Parts and Harness Connector Location

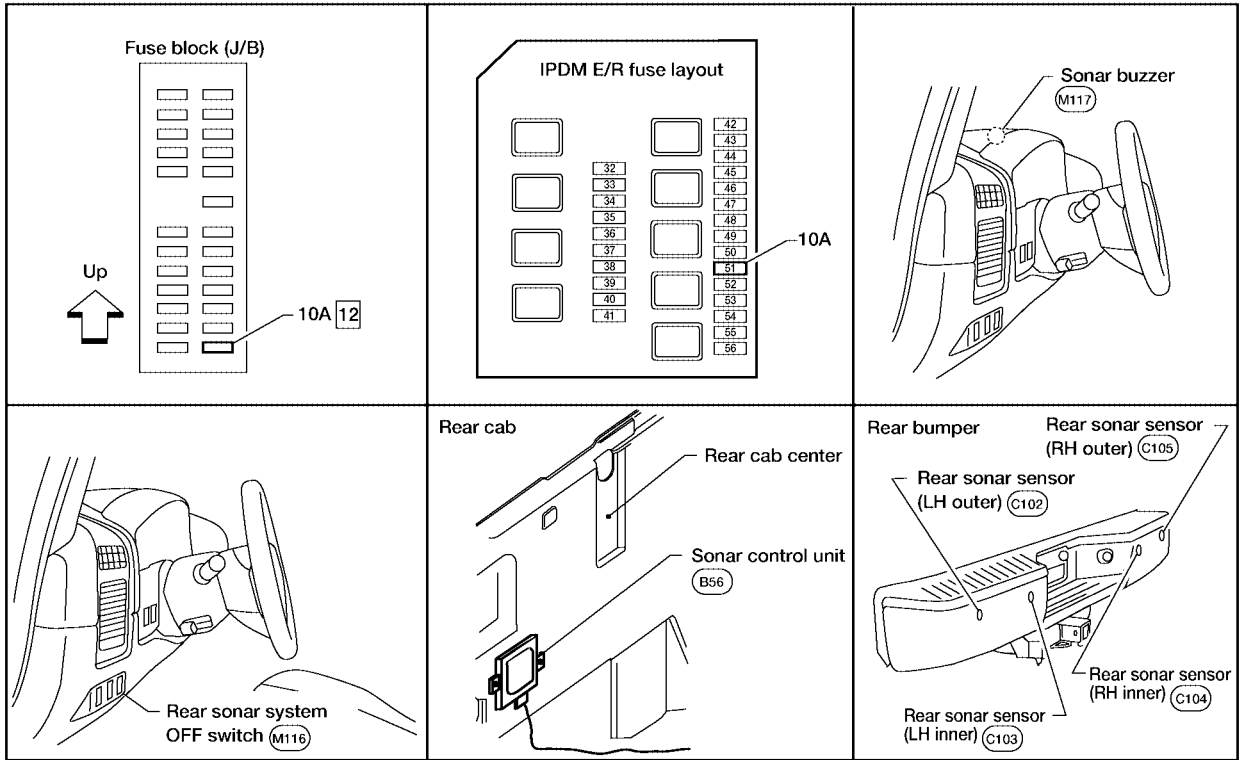
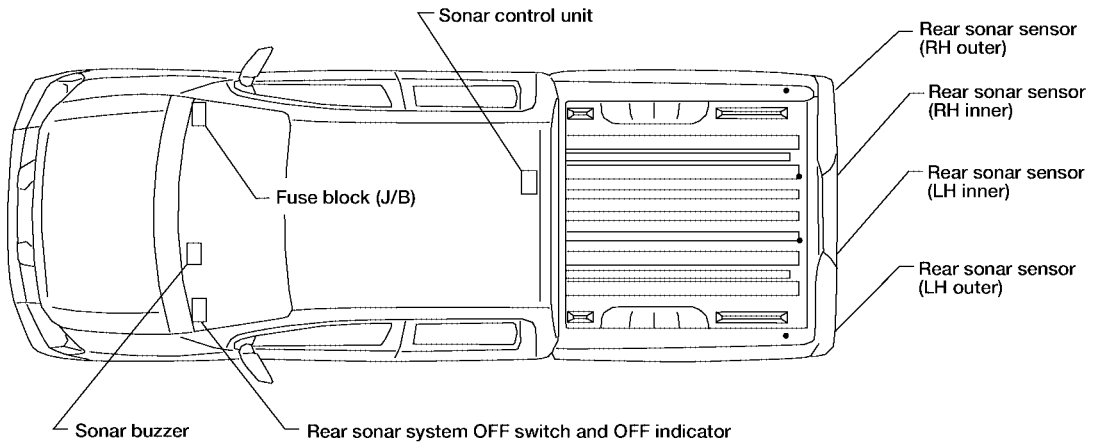

WKIA2871E



# REAR SONAR SYSTEM

EKS0078K

## System Description

### FUNCTION

With the ignition switch in the ON or START position, power is supplied

- through 10A fuse [No. 12 , located in the fuse block (J/B)]
- to sonar control unit terminal 8, and
- through 10A fuse [No. 51, located in the IPDM E/R]
- to back-up lamp relay terminals 1 and 3.

Ground is supplied

- to sonar control unit terminal 6
- through body grounds B7 and B19.

With the ignition switch in the ON or START position, and the transmission gear selector lever in the R position, power is supplied

- to sonar control unit terminal 5
- from back-up lamp relay terminal 5.

With power and ground supplied, transmission gear selector lever in R position, and the rear sonar system OFF switch ON, the rear sonar system will detect obstacles within 1.8 m (5.9 ft.) of the rear sonar sensors. The vehicle operator is notified of obstacles by varied rate of tone from the sonar buzzer depending on distance of obstacle being sensed.

### REAR SONAR SYSTEM OFF SWITCH

With power and ground supplied to the sonar control unit, transmission gear selector lever in R position, the sonar system can be disabled and the sonar buzzer silenced by momentarily pressing the rear sonar system OFF switch. The rear sonar system OFF indicator lamp will be illuminated in the rear sonar system OFF switch.

To disable the rear sonar system, ground is supplied

- to sonar control unit terminal 13
- through rear sonar system OFF switch terminal 1
- through rear sonar system OFF switch terminal 2
- from body grounds M57, M61, and M79.

To light the rear sonar system OFF indicator, power is supplied

- to the rear sonar system OFF switch terminal 5
- from sonar control unit terminal 4.

Ground is supplied

- to the rear sonar system OFF switch terminal 6
- from body grounds M57, M61, and M79.

The rear sonar system and buzzer will be disabled and the rear sonar system OFF indicator will be illuminated until the ignition switch is turned OFF. When the ignition is turned ON, the rear sonar system will be enabled. Depressing the rear sonar system OFF switch momentarily will enable the rear sonar system also. Enabling the rear sonar system will cause the rear sonar system OFF indicator to go out.

### SONAR BUZZER

With the power supplied to the sonar control unit and the transmission gear selector lever in R position, a stationary object that is at least 7.0 cm (2.8 in.) wide and 1.0 m (39.0 in.) tall and that is closer than 1.8 meters (5.9 ft.) will be detected by the rear sonar sensors, causing the sonar buzzer to sound a tone. As the vehicle moves closer to the object, the rate of the tone will increase. When the object is less than 25.0 cm (10 in.) from the rear bumper, the tone will sound continuously.

Power is supplied

- to sonar buzzer terminal +
- from sonar control unit terminal 7.

Ground is supplied

- to sonar buzzer terminal -
- from sonar control unit terminal 3.

A  
B  
C  
D  
E  
F  
G  
H  
I  
J  
L  
M

DI

# REAR SONAR SYSTEM

---

## REAR SONAR SENSOR

With power and ground supplied to the rear sonar sensors, the sonar sensors transmit a 38.4 kHz ultrasonic signal. This signal is reflected back to the sensor by objects large enough and close enough to be detected. The rear sonar sensors measure the time from the transmitted signal to the time the signal is reflected back and sends this information to the sonar control unit.

Power is supplied

- to each rear sonar sensor terminal 1
- from sonar control unit terminal 16.

Ground is supplied

- to each rear sonar sensor terminal 3
- from sonar control unit terminal 15.

Signal is supplied

- to sonar control unit terminals 9, 10, 11 and 12.
- from each rear sonar sensor terminal 2

# REAR SONAR SYSTEM

EKS0078L

## Wiring Diagram — SONAR —

### DI-SONAR-01

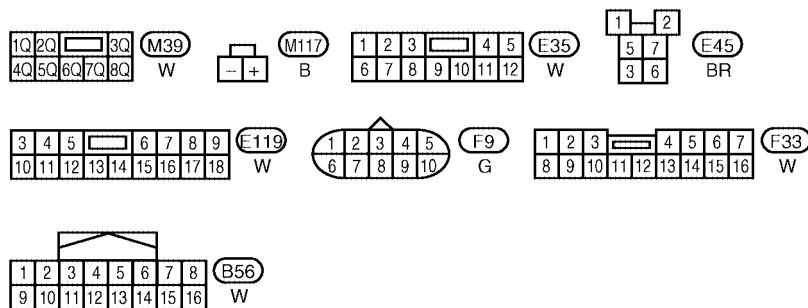
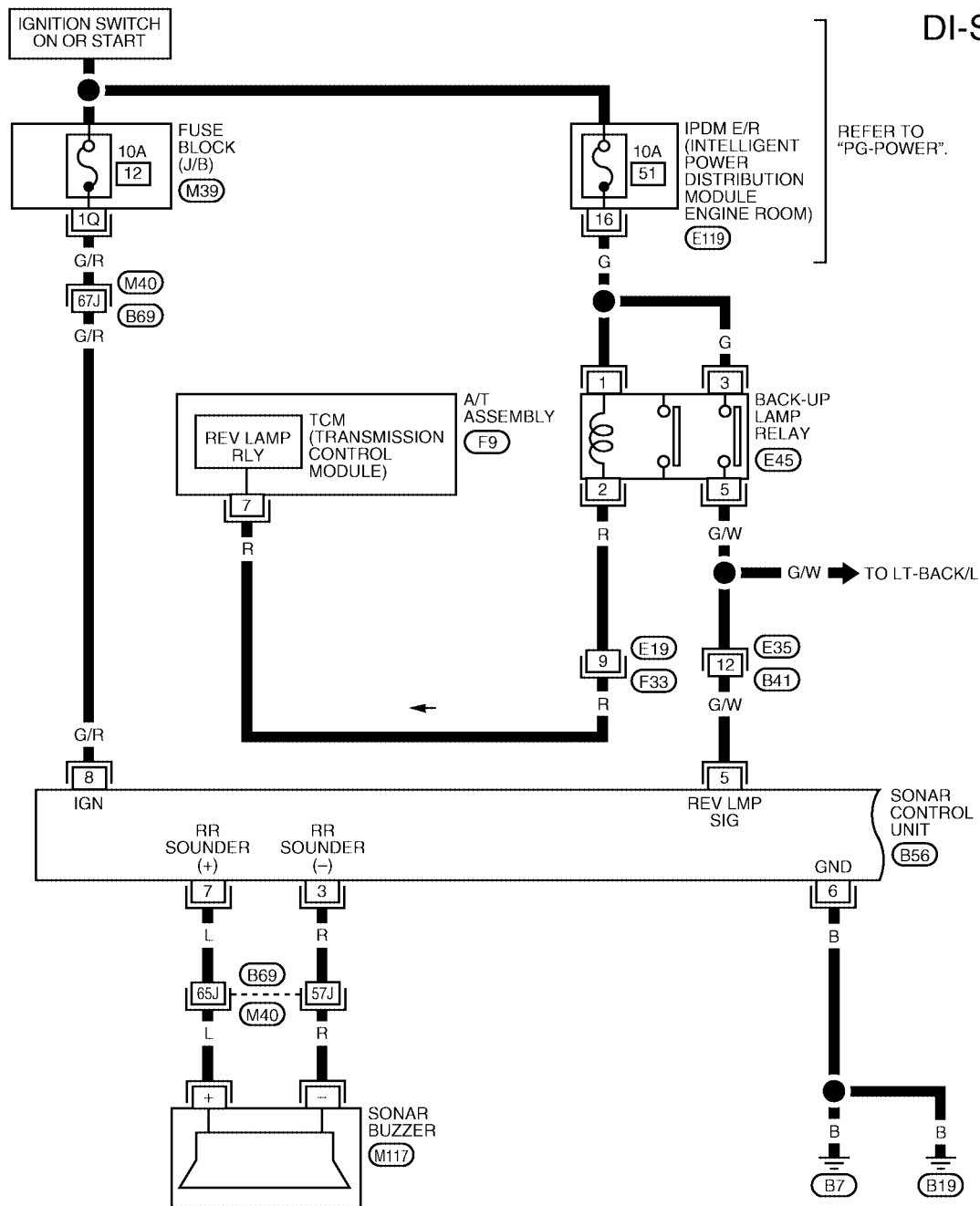

REFER TO THE FOLLOWING.  
**(M40)** - SUPER MULTIPLE JUNCTION (SMJ)

WKWA1176E

# REAR SONAR SYSTEM

## DI-SONAR-02

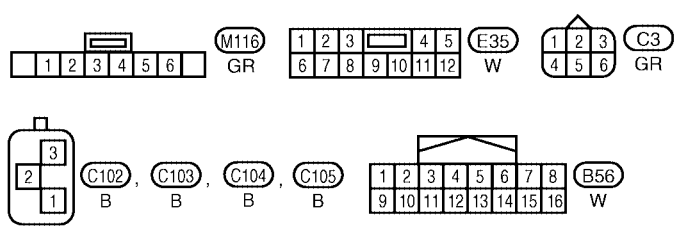
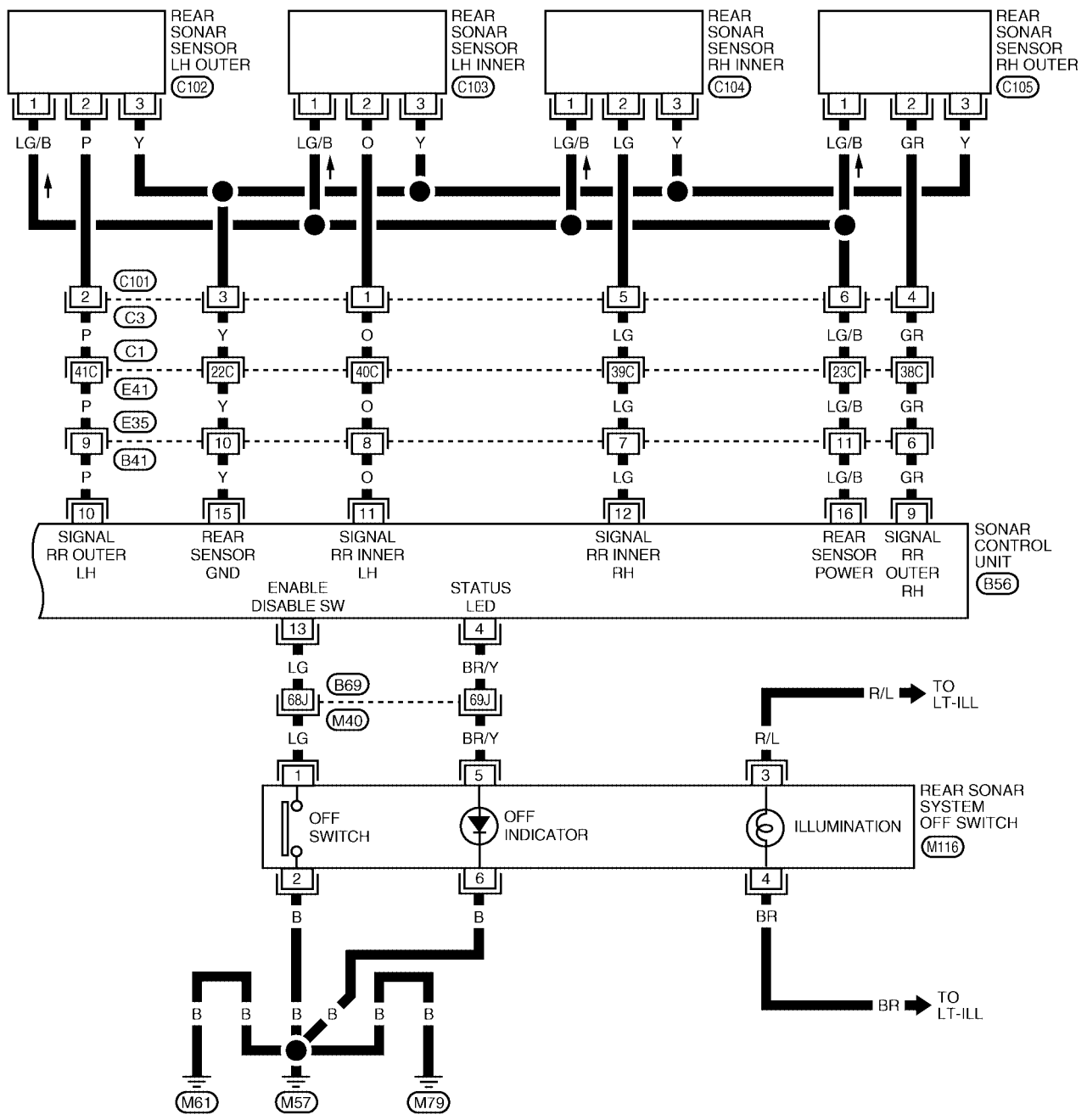

REFER TO THE FOLLOWING.  
 (M40), (C1) - SUPER MULTIPLE JUNCTION (SMJ)

# REAR SONAR SYSTEM

## Terminals And Reference Value For Sonar Control Unit

EKS0078M

TERMINAL (COLOR)	ITEM	CONDITION		Reference value (V) (Approx.)	
		IGNITION SWITCH	OPERATION		
3 (R)	Sonar buzzer return	ON	—	0 - 12 (variable)	
4 (BR/Y)	Rear sonar system OFF indicator output	ON	Rear sonar system OFF switch	ON OFF	0 Battery voltage
			5 (G/W)	Reverse signal	ON
Transmission gear selector lever	Not R position	0			
6 (B)	Sonar control unit ground	—	—	0	
7 (L)	Sonar buzzer drive signal	ON	—	Battery voltage	
8 (G/R)	Sonar control unit power	ON	—	Battery voltage	
9 (GR)	Rear sonar sensor signal - RH outer	ON	<ul style="list-style-type: none"> <li>● Rear sonar system OFF switch ON</li> <li>● Transmission gear selector lever in R position</li> <li>● Distant or no obstacles</li> </ul>	Battery voltage	
10 (P)	Rear sonar sensor signal - LH outer	ON	<ul style="list-style-type: none"> <li>● Rear sonar system OFF switch ON</li> <li>● Transmission gear selector lever in R position</li> <li>● Distant or no obstacles</li> </ul>	Battery voltage	
11 (O)	Rear sonar sensor signal - LH inner	ON	<ul style="list-style-type: none"> <li>● Rear sonar system OFF switch ON</li> <li>● Transmission gear selector lever in R position</li> <li>● Distant or no obstacles</li> </ul>	Battery voltage	
12 (LG)	Rear sonar sensor signal - RH inner	ON	<ul style="list-style-type: none"> <li>● Rear sonar system OFF switch ON</li> <li>● Transmission gear selector lever in R position</li> <li>● Distant or no obstacles</li> </ul>	Battery voltage	
13 (LG)	Rear sonar system OFF switch signal	ON	Rear sonar system OFF switch	ON	0
				OFF	Battery voltage
15 (Y)	Rear sonar sensor ground	ON	—	0	
16 (LG/B)	Rear sonar sensor power	ON	Ignition switch ON	Battery voltage	

## How to Proceed With Trouble Diagnosis

EKS0078N

1. Confirm the symptom or customer complaint.
2. Understand operation description and function description. Refer to [DI-57, "System Description"](#).
3. Perform pre-diagnosis inspection. Refer to [DI-62, "Pre-diagnosis Inspection"](#).
4. Perform self-diagnosis. Refer to [DI-62, "Self-diagnosis Function"](#).
5. Perform the preliminary check. Refer to [DI-64, "Preliminary Check"](#).
6. Check symptom and repair or replace the cause of malfunction. Refer to [DI-65, "Symptom Chart"](#).
7. Clear fault codes. Refer to [DI-63, "IDLING OR CLEARING FAULT CODES MODE"](#).
8. Does the rear sonar system operate properly? If so, go to 9. If not, go to 3.
9. Inspection End.

# REAR SONAR SYSTEM

EKS0078O

## Pre-diagnosis Inspection SENSOR STATUS CHECK

- Check that the rear sonar sensors are properly aligned (bumper is not misaligned, no deformation in sensor mounting area).
- Check that snow, mud, or other foreign objects are not adhering to the rear sonar sensors.
- Check that there is no deformation, scratches, or other damage to the rear sonar sensors.
- Check that water has not accumulated in the rear sonar sensors.

### CAUTION:

Use water, cotton swab, or other soft material for cleaning the sensors.

1. Check that there are no obstacles within each rear sonar sensor's detection range.

	Detection range
Rear sonar sensors	Approx. 1.8 m (5.9 ft.) maximum

2. Check that there are no nearby ultrasound sources (such as the sounds of vehicle horns, motorcycle engines, or truck air brakes).
3. Check that the vehicle is on a level surface.

## Self-diagnosis Function

EKS0078P

There are four modes of self-diagnosis; entering diagnostics, requesting number of fault codes, requesting fault codes, and idling or clearing fault codes. These steps must be followed in order. Self-diagnosis can be manually exited by turning the ignition OFF, or selecting reverse gear. Self-diagnosis will exit unless a fault code request occurs before a message is repeated five times without acknowledgement.

### ENTERING DIAGNOSTICS MODE

1. Turn ignition switch ON. Rear sonar system OFF switch indicator lamp illuminates for three seconds and then turns off.
2. Immediately push rear sonar system OFF switch ten times within five seconds.
3. The sonar buzzer will sound once and the rear sonar system OFF indicator will flash once.

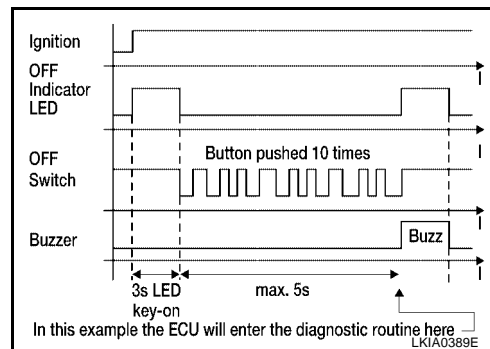

### REQUESTING NUMBER OF FAULT CODES MODE

1. While in diagnostic mode, push rear sonar system OFF switch once.
2. The sonar buzzer will sound once.
3. Rear sonar system OFF indicator will flash once and sonar buzzer will sound once for each fault code detected.
4. There will be a four second pause.
5. The number of fault codes will repeat five times then pause.

#### NOTE:

Self-diagnosis will exit unless requesting fault codes occurs before five repeats ends.

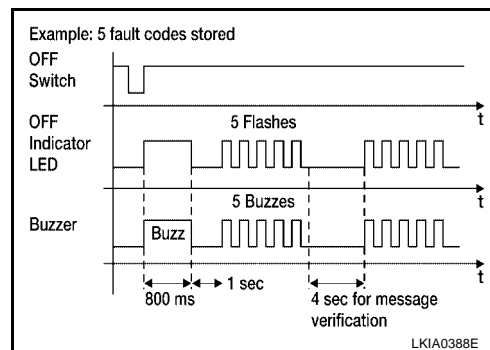

# REAR SONAR SYSTEM

## REQUESTING FAULT CODES MODE

1. While in "requesting number of fault codes" mode, push rear sonar system OFF switch once.
2. The sonar buzzer will sound once.
3. Rear sonar system OFF indicator will flash and sonar buzzer will sound the first digit of the fault code followed by a one second pause.
4. Rear sonar system OFF indicator will flash and sonar buzzer will sound the second digit of the fault code followed by a four second pause.
5. The fault codes will repeat five times then pause.

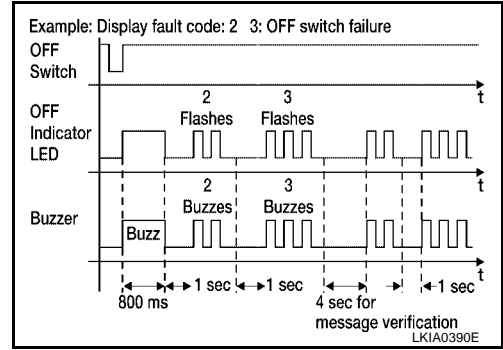

### NOTE:

Requesting fault codes will exit unless the fault code is acknowledged before five repeats ends.

The fault code is acknowledged by pushing the rear sonar system OFF switch once (the sonar buzzer may sound). When all fault codes have been indicated, idle mode will be entered. See the following table for fault code identification.

Fault Code	Malfunction	Page Reference
1 1	Rear sonar sensor LH outer	Check harness for open or short. If NG repair or replace harness. If OK replace sensor. Refer to <a href="#">DI-67, "REAR SONAR SENSORS"</a> .
1 2	Rear sonar sensor LH inner	
1 3	Rear sonar sensor RH inner	
1 4	Rear sonar sensor RH outer	
2 1	Sonar buzzer	<a href="#">DI-66, "SONAR BUZZER"</a>
2 2	Rear sonar system OFF indicator	<a href="#">DI-67, "REAR SONAR SYSTEM OFF INDICATOR"</a>
2 3	Rear sonar system OFF switch	<a href="#">DI-66, "REAR SONAR SYSTEM OFF SWITCH"</a>
2 4	Sonar control unit	Replace sonar control unit. Refer to <a href="#">DI-67, "SONAR CONTROL UNIT"</a> .

## IDLING OR CLEARING FAULT CODES MODE

### NOTE:

While in idle mode, self-diagnosis will automatically exit if no activity occurs for thirty seconds.

1. Push and hold rear sonar system OFF switch for three seconds to reset time-out counter.
2. Push and hold rear sonar system OFF switch for three seconds to clear codes.

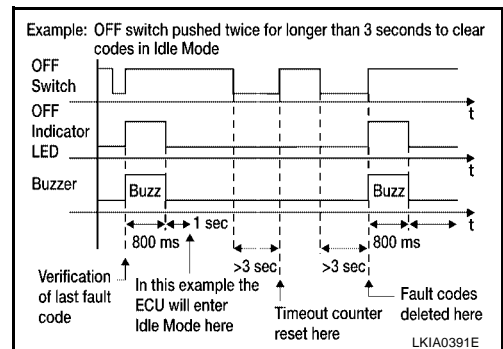

# REAR SONAR SYSTEM

EKS0078Q

## Preliminary Check INSPECTION FOR POWER SUPPLY AND GROUND CIRCUIT

### 1. CHECK FUSES

Check for blown rear sonar system fuses.

Unit	Power Source	Fuse
Sonar control unit	ON or START	12

Refer to [DI-59, "Wiring Diagram — SONAR —"](#).

OK or NG

OK >> GO TO 2.

NG >> If fuse is blown, be sure to eliminate cause of problem before installing new fuse. Refer to [PG-4, "POWER SUPPLY ROUTING CIRCUIT"](#).

### 2. CHECK POWER SUPPLY CIRCUIT

1. Disconnect sonar control unit connector.
2. Check voltage between sonar control unit connector B56 terminal 8 (G/R) and ground.

Terminals		Ignition switch position	
(+)		ON or START	
Connector	Terminal (Wire color)	(-)	
B56	8 (G/R)	Ground	Battery voltage

OK or NG

OK >> GO TO 3.

NG >> Check harness for open between sonar control unit and fuse.

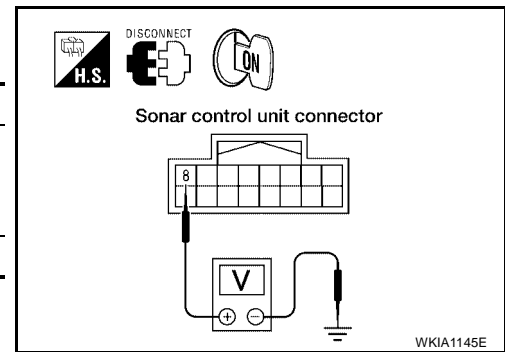

### 3. CHECK GROUND CIRCUIT

1. Turn ignition switch OFF.
2. Check continuity between sonar control unit B56 terminal 6 and ground.

Terminals		Continuity	
(+)		(-)	
Connector	Terminal (Wire color)	(-)	
B56	6 (B)	Ground	Yes

OK or NG

OK >> Inspection End.

NG >> Check harness ground circuit.

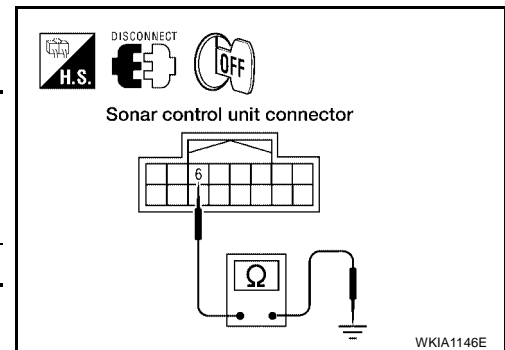



# REAR SONAR SYSTEM

EKS0078R

## Symptom Chart

Symptom	Repair order
When the rear sonar system OFF switch is OFF, the indicator lamp does not light and the buzzer does not sound.	<ol style="list-style-type: none"> <li>1. Check rear sonar system OFF switch for malfunction. Refer to <a href="#">DI-66, "REAR SONAR SYSTEM OFF SWITCH"</a> .</li> <li>2. Check rear sonar system OFF switch ground circuit.</li> <li>3. Check harness and connections between rear sonar system OFF switch and sonar control unit.</li> <li>4. Replace sonar control unit. Refer to <a href="#">DI-67, "SONAR CONTROL UNIT"</a> .</li> </ol>
When the rear sonar system OFF switch is OFF, the indicator lamp does not light but buzzer sounds.	<ol style="list-style-type: none"> <li>1. Check rear sonar system OFF indicator for malfunction. Refer to <a href="#">DI-67, "REAR SONAR SYSTEM OFF INDICATOR"</a> .</li> <li>2. Check harness and connections between rear sonar system OFF indicator and sonar control unit.</li> <li>3. Replace sonar control unit. Refer to <a href="#">DI-67, "SONAR CONTROL UNIT"</a> .</li> </ol>
When the rear sonar system OFF switch is OFF, the sonar buzzer does not sound but indicator lamp illuminates.	<ol style="list-style-type: none"> <li>1. Check sonar buzzer. Refer to <a href="#">DI-66, "SONAR BUZZER"</a> .</li> <li>2. Check harness and connections between sonar buzzer and sonar control unit.</li> <li>3. Replace sonar control unit. Refer to <a href="#">DI-67, "SONAR CONTROL UNIT"</a> .</li> </ol>
When rear sonar system OFF switch is ON, the rear sonar system OFF indicator lamp lights up and the sonar buzzer sounds intermittently (for about 4 seconds).	<ol style="list-style-type: none"> <li>1. Check harness between rear sonar sensors and sonar control unit for an open condition.</li> <li>2. Check rear sonar sensors for malfunction.</li> <li>3. Replace sonar control unit. Refer to <a href="#">DI-67, "SONAR CONTROL UNIT"</a> .</li> </ol>
The rear sonar system operates with the rear sonar system OFF switch OFF.	<ol style="list-style-type: none"> <li>1. Check rear sonar system OFF switch for malfunction. Refer to <a href="#">DI-66, "REAR SONAR SYSTEM OFF SWITCH"</a> .</li> <li>2. Check rear sonar system OFF switch ground circuit.</li> <li>3. Check harness and connections between rear sonar system OFF switch and sonar control unit.</li> <li>4. Replace sonar control unit. Refer to <a href="#">DI-67, "SONAR CONTROL UNIT"</a> .</li> </ol>
When the transmission gear selector lever is in the R position and the rear sonar system OFF switch is OFF, the sonar system does not operate.	<ol style="list-style-type: none"> <li>1. Check for PNP switch failure. Refer to <a href="#">AT-97, "SELF-DIAGNOSTIC RESULT MODE"</a> .</li> <li>2. Check harness and connections between sonar control unit and PNP/reverse lamp circuits.</li> <li>3. Replace sonar control unit. Refer to <a href="#">DI-67, "SONAR CONTROL UNIT"</a> .</li> </ol>

A  
B  
C  
D  
E  
F  
G  
H  
I  
J  
DI  
L  
M

# REAR SONAR SYSTEM

Symptom	Repair order
<p>When the rear sonar system OFF switch is OFF, the indicator lamp lights up and buzzer sounds although there is no obstacle within the detection range.</p>	<ol style="list-style-type: none"> <li>1. Check for adhesion of snow, mud, or other foreign objects to rear sonar sensors; dew condensation; etc. Refer to <a href="#">DI-62. "Pre-diagnosis Inspection"</a> .</li> <li>2. Check that the rear sonar sensors are properly aligned (bumper is not misaligned, no deformation in sensor mounting area)</li> <li>3. Check harness and connections between rear sonar sensors and sonar control unit.</li> <li>4. Check rear sonar sensors for malfunction.</li> <li>5. Replace sonar control unit. Refer to <a href="#">DI-67. "SONAR CONTROL UNIT"</a> .</li> </ol>
<p>The rear sonar sensors do not operate according to the distance between each sensor and the obstacle. (There is a large error in the obstacle detection distance.)</p>	<ol style="list-style-type: none"> <li>1. Check rear sonar sensors for malfunction.</li> <li>2. Replace sonar control unit. Refer to <a href="#">DI-67. "SONAR CONTROL UNIT"</a> .</li> <li>3. Check for adhesion of snow, mud, or other foreign objects to rear sonar sensors; dew condensation; etc. Refer to <a href="#">DI-62. "Pre-diagnosis Inspection"</a> .</li> <li>4. Check that the rear sonar sensors are properly aligned (bumper is not misaligned, no deformation in sensor mounting area.)</li> </ol>

## Component Inspection SONAR BUZZER

EKS0078S

1. Disconnect the sonar buzzer connector.
2. Check continuity between buzzer connector M117 terminal (+) and terminal (-)

(+) - (-) : Continuity should exist

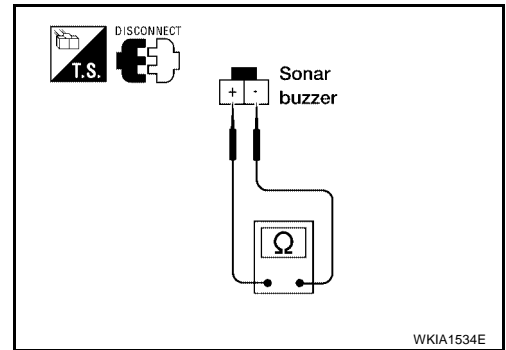

## REAR SONAR SYSTEM OFF SWITCH

Disconnect the rear sonar system OFF switch M116. Check the continuity between following terminals.

Rear sonar system OFF switch	Terminal to be inspected	Continuity
ON	1 - 2	Yes
OFF		No

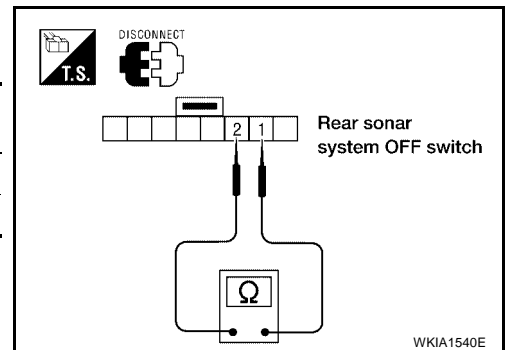

# REAR SONAR SYSTEM

## REAR SONAR SYSTEM OFF INDICATOR

Disconnect the rear sonar system OFF switch connector M116, and apply battery voltage (approx. 12V) to terminal 5. Check the rear sonar system OFF indicator operation when terminal 6 is connected to battery ground.

	Terminal to be inspected	Condition	Operation
Rear sonar system OFF switch	5	Approx. 12V	Rear sonar system OFF indicator lights
	6	Ground	

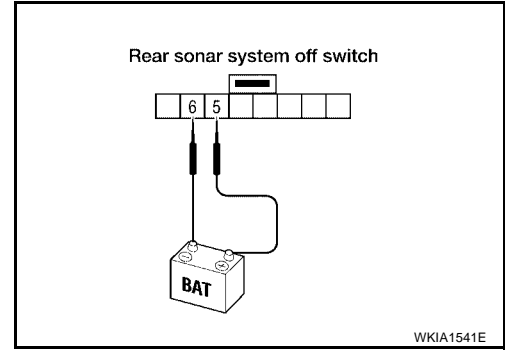

## Removal and Installation of Rear Sonar System REAR SONAR SENSORS

Refer to [EI-18, "Removal and Installation"](#) .

### SONAR CONTROL UNIT

1. Remove rear seat back. Refer to [SE-100, "Removal and Installation"](#) .
2. Remove rear finisher to gain access to sonar control unit. Refer to [EI-39, "REAR"](#) .
3. Disconnect electrical connector then remove sonar control unit. Refer to [DI-56, "Component Parts and Harness Connector Location"](#) .
4. Follow the steps in reverse order for installation.

A  
B  
C  
D  
E  
F  
G  
H  
I  
J  
DI  
L  
M

# REAR SONAR SYSTEM

---