

SECTION **AP**

ADJUSTABLE PEDAL

CONTENTS

PRECAUTIONS	2	Automatic Drive Positioner Interlocking Adjustable Pedal	3
Precautions for Supplemental Restraint System (SRS) "AIR BAG" and "SEAT BELT PRE-TENSIONER"	2	Adjustable Pedal (Only Manual Operation Model)....	3
Trouble Diagnosis Precaution	2	Trouble Diagnosis	7
ADJUSTABLE PEDAL SYSTEM	3	Removal and Installation	15

A
B
C
D
E
F
G
H
J
K
L
M

AP

PRECAUTIONS

PRECAUTIONS

PFP:00001

Precautions for Supplemental Restraint System (SRS) “AIR BAG” and “SEAT BELT PRE-TENSIONER”

EIS0020S

The Supplemental Restraint System such as “AIR BAG” and “SEAT BELT PRE-TENSIONER”, used along with a front seat belt, helps to reduce the risk or severity of injury to the driver and front passenger for certain types of collision. This system includes seat belt switch inputs and dual stage front air bag modules. The SRS system uses the seat belt switches to determine the front air bag deployment, and may only deploy one front air bag, depending on the severity of a collision and whether the front occupants are belted or unbelted. Information necessary to service the system safely is included in the SRS and SB section of this Service Manual.

WARNING:

- To avoid rendering the SRS inoperative, which could increase the risk of personal injury or death in the event of a collision which would result in air bag inflation, all maintenance must be performed by an authorized NISSAN/INFINITI dealer.
- Improper maintenance, including incorrect removal and installation of the SRS, can lead to personal injury caused by unintentional activation of the system. For removal of Spiral Cable and Air Bag Module, see the SRS section.
- Do not use electrical test equipment on any circuit related to the SRS unless instructed to in this Service Manual. SRS wiring harnesses can be identified by yellow and/or orange harnesses or harness connectors.

Trouble Diagnosis Precaution

EIS0020T

When you read wiring diagrams, refer to the following:

- [GI-15, "How to Read Wiring Diagrams"](#).
- [PG-4, "POWER SUPPLY ROUTING CIRCUIT"](#).

When you perform trouble diagnosis, refer to the following:

- [GI-11, "HOW TO FOLLOW TEST GROUPS IN TROUBLE DIAGNOSES"](#).
- [GI-27, "How to Perform Efficient Diagnosis for an Electrical Incident"](#).

Check for any service bulletins before servicing the vehicle.

ADJUSTABLE PEDAL SYSTEM

PF9:98800

ADJUSTABLE PEDAL SYSTEM

Automatic Drive Positioner Interlocking Adjustable Pedal

EIS0020U

Automatic drive positioner interlocking adjustable pedal. Refer to [SE-11, "AUTOMATIC DRIVE POSITIONER"](#).

Adjustable Pedal (Only Manual Operation Model)

EIS0020V

COMPONENT PARTS AND HARNESS CONNECTOR LOCATION

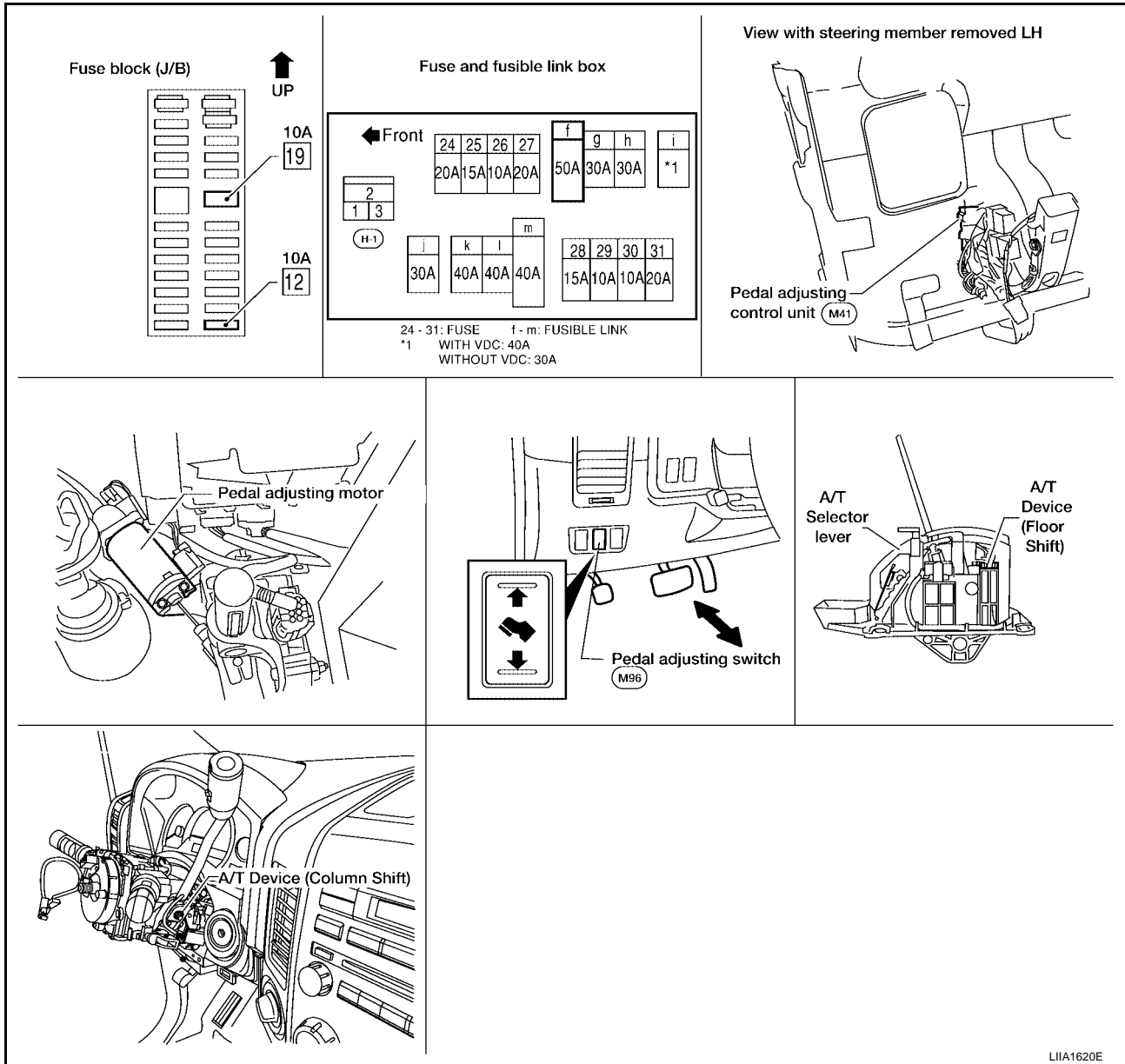

SYSTEM DESCRIPTION

The adjustable pedal system power supply is controlled by pedal adjusting control unit. Power is supplied at all times

- through 50A fuse (letter f , located in the fuse and fusible link box),
- to circuit breaker-2 terminal 2,
- through circuit breaker-2 terminal 1,
- to pedal adjusting control unit terminal 5.

With the ignition switch ON or START, power is supplied

- through 10A fuse [No. 12, located in the fuse block (J/B)],
- to pedal adjusting control unit terminal 4.

A
B
C
D
E
F
G
H
AP
J
K
L
M

ADJUSTABLE PEDAL SYSTEM

Ground is supplied

- to pedal adjusting switch terminal 4 and
- to pedal adjusting control unit terminal 1,
- through body grounds M57, M61 and M79.

Column Shift

When the A/T selector lever is in other than P position, ground is supplied

- to pedal adjusting control unit terminal 3,
- through A/T device terminal 8,
- through A/T device terminal 1,

Floor Shift

When the A/T selector lever is in other than P position, ground is supplied

- to pedal adjusting control unit terminal 3,
- through A/T device terminal 6,
- through A/T device terminal 5,

Then pedal adjusting control unit recognizes that A/T selector lever is in other than P position.

When A/T selector lever is shifted to the P position, power is supplied

- through pedal adjusting control unit terminal 7,
- to pedal adjusting switch terminal 1.

With power supplied, pedal adjusting switch is energized.

When pedal is adjusted forward, power is supplied

- through pedal adjusting switch terminal 3,
- to pedal adjusting motor terminal +.

Then ground is supplied

- to pedal adjusting motor terminal -,
- through pedal adjusting switch terminal 2,
- through pedal adjusting switch terminal 4,
- through body grounds M57, M61 and M79.

With power and ground are supplied, accelerator and brake pedal moves forward.

When pedal is adjusted backward, power is supplied

- through pedal adjusting switch terminal 2,
- to pedal adjusting motor terminal -.

Then ground is supplied

- to pedal adjusting motor terminal +,
- through pedal adjusting switch terminal 3,
- through pedal adjusting switch terminal 4,
- through body grounds M57, M61 and M79.

With power and ground are supplied, accelerator and brake pedal move backward.

ADJUSTABLE PEDAL SYSTEM

WIRING DIAGRAM -PEDAL-

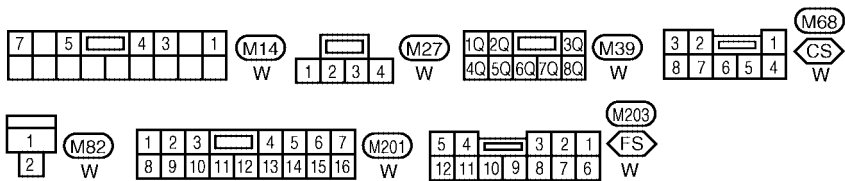
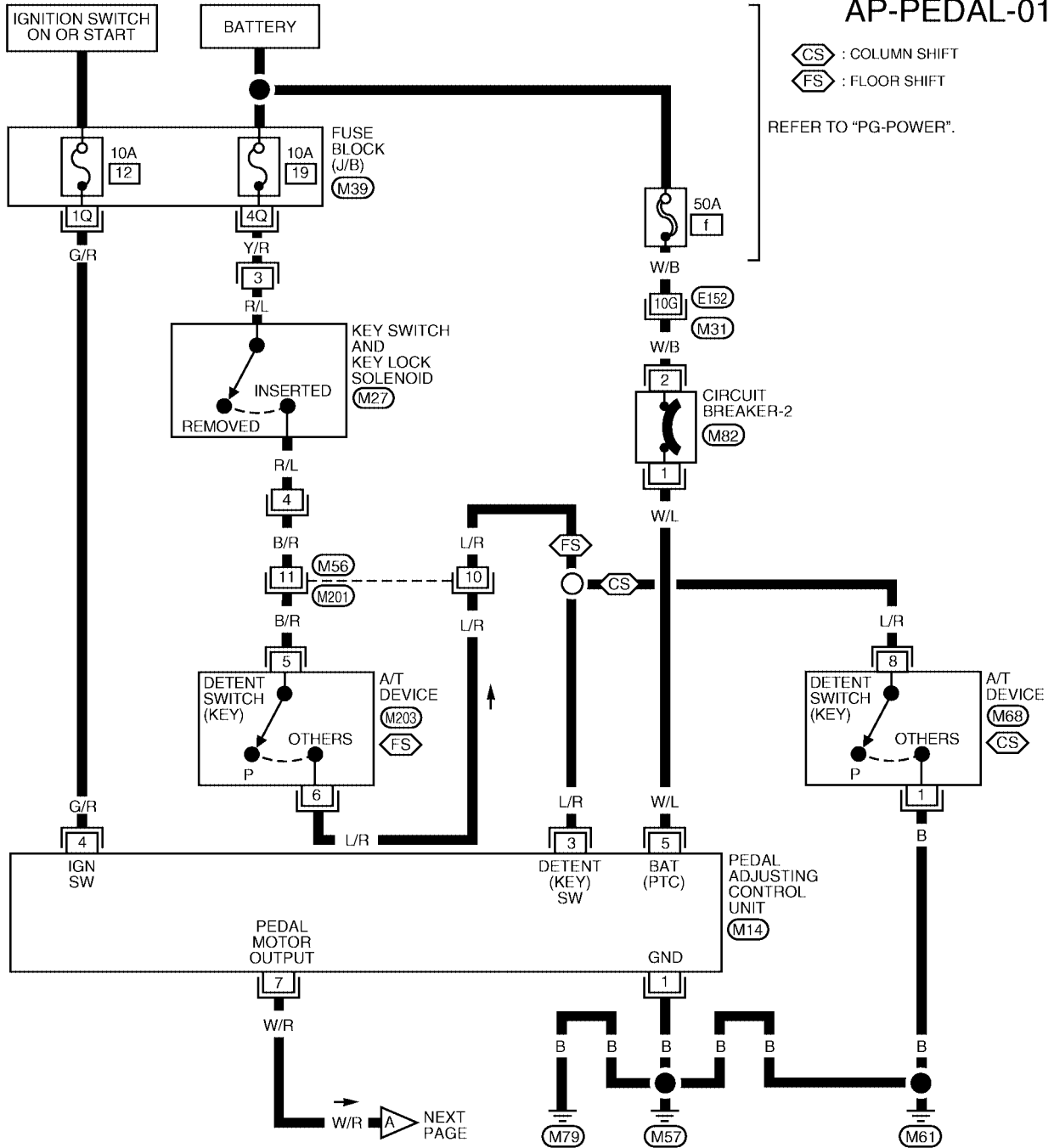

REFER TO THE FOLLOWING.
(M31) - SUPER MULTIPLE JUNCTION (SMJ)

WIWA0256E

ADJUSTABLE PEDAL SYSTEM

AP-PEDAL-02

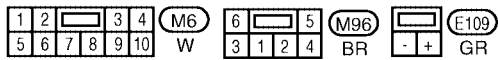
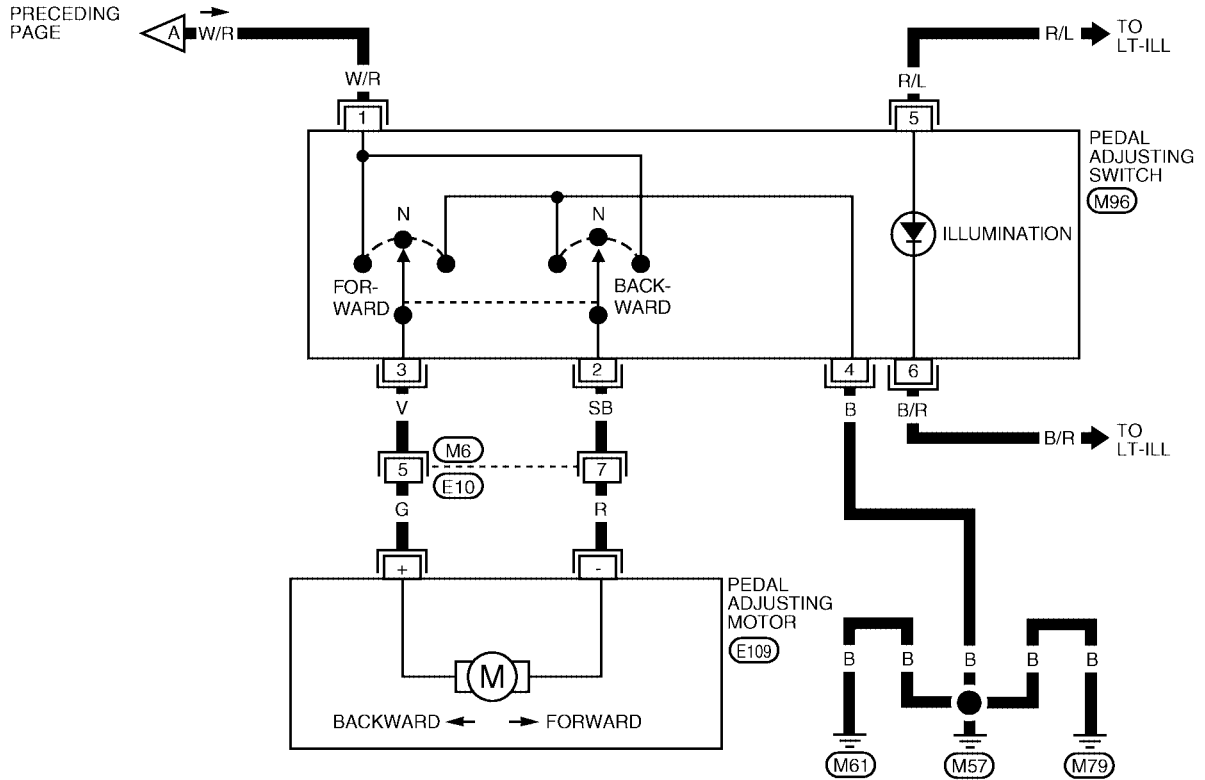

WIWA0191E

ADJUSTABLE PEDAL SYSTEM

TERMINAL AND REFERENCE VALUE FOR PEDAL ADJUSTING CONTROL UNIT

TERMI- NAL	WIRE COLOR	ITEM	CONDITON	VOLTAGE (V) (Approx.)
1	B	Ground	—	0
3	L/R	Detent (key) switch signal	Selector lever in other than P position	0
			Except the above	Battery voltage
4	G/R	Ignition switch (ON or START)	Ignition switch (ON or START position)	Battery voltage
5	W/L	Battery power supply	—	Battery voltage
7	W/R	Pedal adjusting switch power supply out- put	Ignition switch ON Selector lever in other than P position	0
			Ignition switch ON Selector lever in P position	Battery voltage

Trouble Diagnosis

EIS0020W

WORK FLOW

1. Check the symptom and customer's requests.
2. Perform the preliminary check. Refer to [AP-7, "PRELIMINARY CHECK"](#) .
3. According to the trouble diagnosis chart, repair or replace the cause of the malfunction. Refer to [AP-8, "TROUBLE DIAGNOSIS CHART BY SYMPTOM"](#) .
4. Does adjustable pedal system operate normally?
YES: GO TO 5.
NO: GO TO 3.
5. INSPECTION END.

PRELIMINARY CHECK

1. CHECK ADJUSTABLE PEDAL MECHANISM

Check the following.

- Movable part of accelerator pedal or brake pedal is deformed, or there is foreign material in it.
- Accelerator pedal or brake pedal is deformed or broken.

OK or NG

- OK >> Preliminary check is OK.
NG >> Repair the malfunctioning part and check again.

ADJUSTABLE PEDAL SYSTEM

TROUBLE DIAGNOSIS CHART BY SYMPTOM

NOTE:

Always check the WORK FLOW before troubleshooting. Refer to [AP-7, "WORK FLOW"](#) .

Symptom	Diagnosis / service procedure	Reference page
Adjustable pedal system does not operate.	1. Pedal adjusting control unit power supply and ground circuit inspection.	AP-9
	2. Pedal adjusting switch power supply and ground circuit inspection.	AP-12
	3. Pedal adjusting motor circuit inspection.	AP-13
	4. Replace pedal adjusting motor.	AP-15
Adjustable pedal system does operate when ignition switch is turned ON and A/T selector lever is in other than P position.	1. A/T device circuit inspection.	AP-11
	2. Pedal adjusting control unit signal inspection.	AP-8
	3. Replace pedal adjusting control unit.	—
Adjustable pedal system does not operate when ignition switch is turned ON and A/T selector lever is in P position.	1. A/T device circuit inspection.	AP-11

PEDAL ADJUSTING CONTROL UNIT IGNITION SIGNAL INSPECTION

1. CHECK FUSE

Check 10A fuse [No. 12, located in fuse block (J/B)].

NOTE:

Refer to [AP-3, "COMPONENT PARTS AND HARNESS CONNECTOR LOCATION"](#) .

OK or NG

OK >> GO TO 2.

NG >> If fuse is blown, be sure to eliminate cause of malfunction before installing new fuse. Refer to [PG-4, "POWER SUPPLY ROUTING CIRCUIT"](#) .

2. CHECK PEDAL ADJUSTING CONTROL UNIT IGNITION POWER SUPPLY CIRCUIT

1. Disconnect pedal adjusting control unit.
2. Check voltage between pedal adjusting control unit connector and ground.

Connector	Terminal (Wire color)		Condition	Voltage (V) (Approx.)
	(+)	(-)		
M14	4 (G/R)	Ground	Ignition switch ON	Battery voltage
			Ignition switch OFF	0

OK or NG

OK >> Pedal adjusting control unit ignition signal is OK.

NG >> Repair or replace the harness.

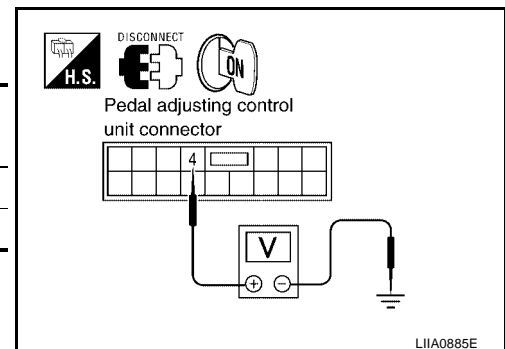

ADJUSTABLE PEDAL SYSTEM

PEDAL ADJUSTING CONTROL UNIT POWER SUPPLY AND GROUND INSPECTION

1. CHECK PEDAL ADJUSTING CONTROL UNIT OUTPUT POWER SUPPLY

1. Turn ignition OFF.
2. Check voltage between pedal adjusting control unit connector M14 terminal 7 and ground.

7 (W/R) – Ground : Battery voltage

OK or NG

- OK >> Pedal adjusting control unit power supply and ground is OK.
NG >> GO TO 2.

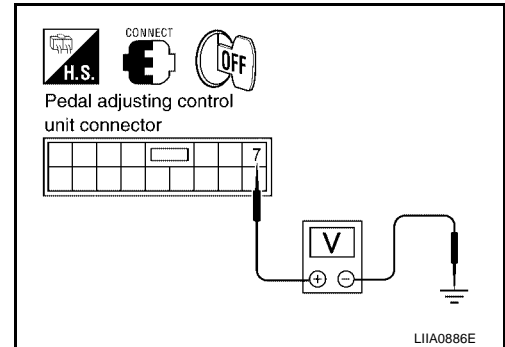

2. CHECK PEDAL ADJUSTING CONTROL UNIT POWER SUPPLY CIRCUIT

1. Disconnect pedal adjusting control unit.
2. Check voltage between pedal adjusting control unit connector M14 terminal 5 and ground.

5 (W/L) - Ground : Battery voltage

OK or NG

- OK >> GO TO 3.
NG >> Repair or replace the harness.

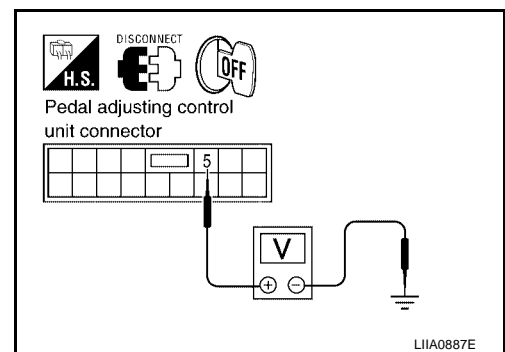

3. CHECK PEDAL ADJUSTING CONTROL UNIT GROUND CIRCUIT

Check continuity between pedal adjusting control unit connector M14 terminal 1 and ground.

1 (B) - Ground : Continuity should exist.

OK or NG

- OK >> Replace pedal adjusting control unit.
NG >> Repair or replace the harness.

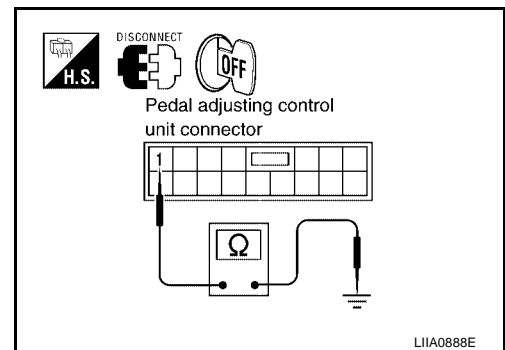

A
B
C
D
E
F
G
H
AP
J
K
L
M

ADJUSTABLE PEDAL SYSTEM

A/T DEVICE CIRCUIT INSPECTION / FLOOR SHIFT

1. CHECK PEDAL ADJUSTING CONTROL UNIT INPUT SIGNAL

1. Disconnect pedal adjusting control unit.
2. Turn ignition switch ON.
3. Check voltage between pedal adjusting control unit connector and ground.

Connector	Terminal (Wire color)		Condition	Voltage (V) (Approx.)
	(+)	(-)		
M14	3 (L/R)	Ground	P position	Battery voltage
			Other than P position	0

OK or NG

- OK >> A/T device circuit is OK.
 NG >> GO TO 2.

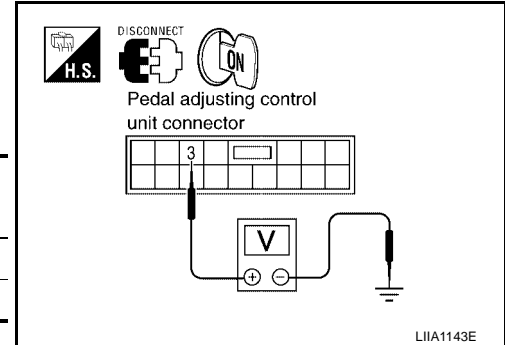

2. CHECK A/T DEVICE POWER SUPPLY CIRCUIT

1. Disconnect A/T device.
2. Check voltage between A/T device connector M203 terminal 5 and ground.

5 (B/R) - Ground : Battery voltage

OK or NG

- OK >> GO TO 4.
 NG >> GO TO 3.

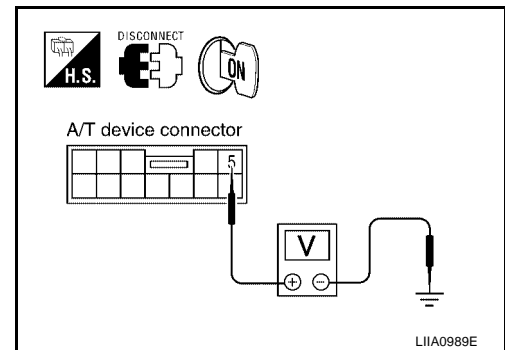

3. CHECK A/T DEVICE HARNESS

1. Turn ignition switch OFF.
2. Disconnect pedal adjusting control unit.
3. Check continuity between pedal adjusting control unit connector M14 terminal 3 and A/T device connector M203 terminal 6.

3 (L/R) - 6 (L/R) : Continuity should exist.

4. Check continuity between pedal adjusting control unit connector M14 terminal 3 and ground.

3 (L/R) - Ground : Continuity should not exist.

OK or NG

- OK >> Check the condition of the harness and connector.
 NG >> Repair or replace harness.

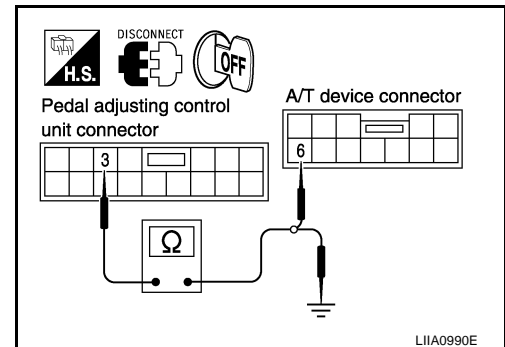

ADJUSTABLE PEDAL SYSTEM

4. CHECK A/T DEVICE

Check continuity between A/T device as follows.

Terminal		Condition	Continuity
5	6	P position	No
		Other than P position	Yes

OK or NG

- OK >> Inspect shift lock system. Refer to [AT-244, "A/T SHIFT LOCK SYSTEM"](#) .
- NG >> Replace control device assembly. Refer to [AT-244, "A/T SHIFT LOCK SYSTEM"](#) .

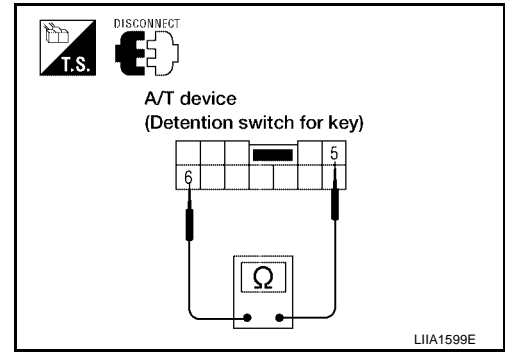

A/T DEVICE CIRCUIT INSPECTION / COLUMN SHIFT

1. CHECK PEDAL ADJUSTING CONTROL UNIT INPUT SIGNAL

1. Disconnect pedal adjusting control unit.
2. Turn ignition switch ON.
3. Check voltage between pedal adjusting control unit connector and ground.

Connector	Terminal (Wire color)		Condition	Voltage (V) (Approx.)
	(+)	(-)		
M14	3 (L/R)	Ground	P position	Battery voltage
			Other than P position	0

OK or NG

- OK >> A/T device circuit is OK.
- NG >> GO TO 2.

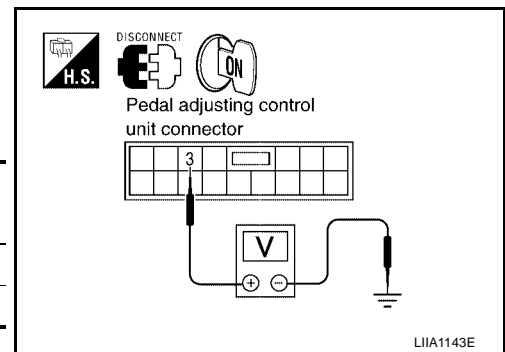

2. CHECK A/T DEVICE POWER SUPPLY CIRCUIT

1. Disconnect A/T device.
2. Check voltage between A/T device connector M68 terminal 1 and ground.

1 (B) - Ground : Battery voltage

OK or NG

- OK >> GO TO 4.
- NG >> GO TO 3.

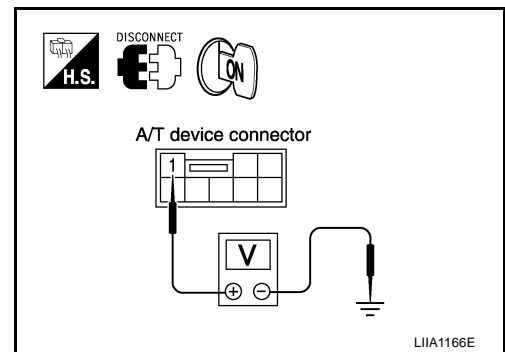

ADJUSTABLE PEDAL SYSTEM

3. CHECK A/T DEVICE HARNESS

1. Turn ignition switch OFF.
2. Disconnect pedal adjusting control unit.
3. Check continuity between pedal adjusting control unit connector M14 terminal 3 and A/T device connector M68 terminal 8.

3 (L/R) - 8 (L/R) : Continuity should exist.

4. Check continuity between pedal adjusting control unit connector M14 terminal 3 and ground.

3 (L/R) - Ground : Continuity should not exist.

OK or NG

- OK >> Check the condition of the harness and connector.
 NG >> Repair or replace harness.

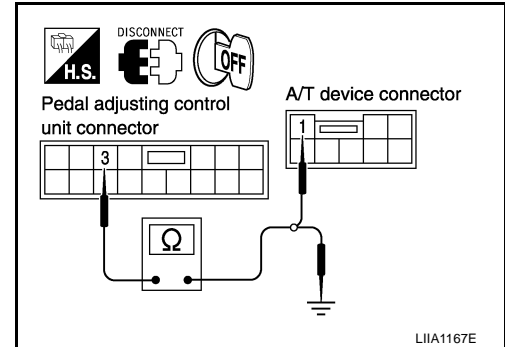

LIA1167E

4. CHECK A/T DEVICE

Check continuity between A/T device as follows.

Terminal		Condition	Continuity
1	8	P position	No
		Other than P position	Yes

OK or NG

- OK >> Inspect shift lock system. Refer to [AT-244, "A/T SHIFT LOCK SYSTEM"](#) .
 NG >> Replace column shift control. Refer to [AT-241, "SHIFT CONTROL SYSTEM"](#) .

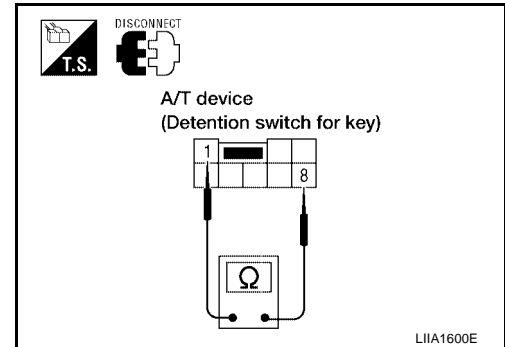

LIA1600E

PEDAL ADJUSTING SWITCH POWER SUPPLY AND GROUND INSPECTION

1. CHECK PEDAL ADJUSTING SWITCH POWER SUPPLY

1. Turn ignition switch OFF.
2. Disconnect pedal adjusting switch.
3. Check voltage between pedal adjusting switch connector M96 terminal 1 and ground.

1 (W/R) - Ground : Battery voltage

OK or NG

- OK >> GO TO 3.
 NG >> GO TO 2.

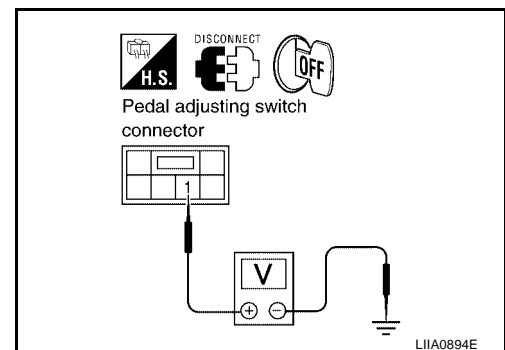

LIA0894E

ADJUSTABLE PEDAL SYSTEM

2. CHECK PEDAL ADJUSTING SWITCH HARNESS

1. Disconnect pedal adjusting control unit.
2. Check continuity between pedal adjusting control unit connector M14 terminal 7 and pedal adjusting switch connector M96 terminal 1.
7 (W/R) - 1 (W/R) : Continuity should exist.
3. Check continuity between pedal adjusting control unit connector M14 terminal 7 and ground.
7 (W/R) - Ground : Continuity should not exist.

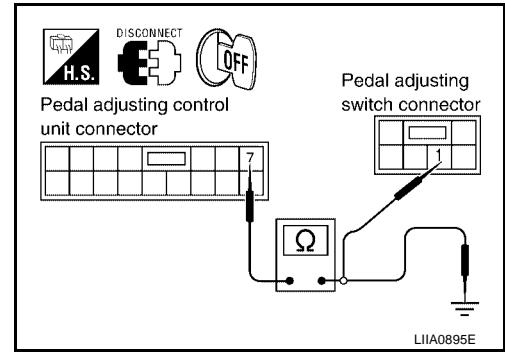

OK or NG

- OK >> Check the condition of the harness and connector.
- NG >> Repair or replace harness.

3. CHECK PEDAL ADJUSTING SWITCH GROUND CIRCUIT

Check continuity between pedal adjusting switch connector M96 terminal 4 and ground.

4 (B) - Ground : Continuity should exist.

OK or NG

- OK >> Pedal adjusting switch power supply and ground circuit is OK.
- NG >> Repair or replace the harness.

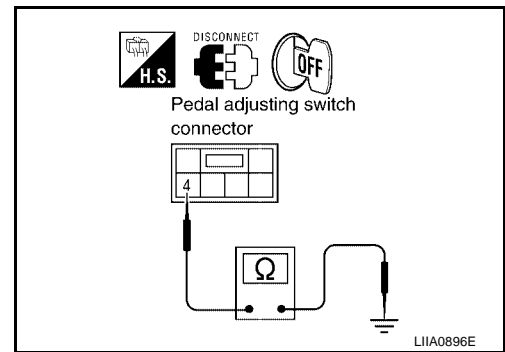

PEDAL ADJUSTING MOTOR CIRCUIT INSPECTION

1. CHECK PEDAL ADJUSTING SWITCH

1. Turn ignition switch OFF.
2. Disconnect pedal adjusting switch.
3. Check continuity between pedal adjusting switch as follows.

Terminals	Condition	Continuity	
3	1	Pedal adjusting switch forward.	Yes
		Pedal adjusting switch neutral.	No
	4	Pedal adjusting switch backward.	Yes
		Pedal adjusting switch neutral.	No
2	1	Pedal adjusting switch backward.	Yes
		Pedal adjusting switch neutral.	No
	4	Pedal adjusting switch forward.	Yes
		Pedal adjusting switch neutral.	No

OK or NG

- OK >> GO TO 2.
- NG >> Replace pedal adjusting switch.

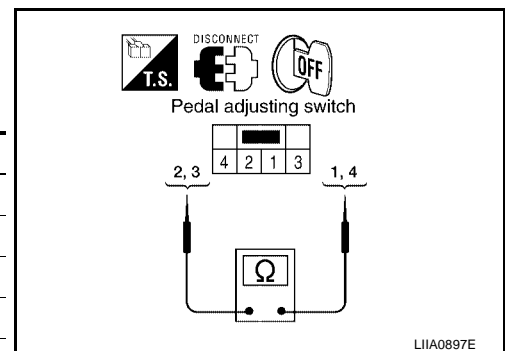

ADJUSTABLE PEDAL SYSTEM

2. CHECK PEDAL ADJUSTING MOTOR HARNESS

1. Disconnect pedal adjusting motor.
2. Check continuity between pedal adjusting switch connector M96 terminals 2, 3 and pedal adjusting motor connector E109 terminals +, -.

2 (SB) - - (R) : Continuity should exist.

3 (V) - + (G) : Continuity should exist.

3. Check continuity between pedal adjusting switch connector M96 terminals 2 (SB), 3 (V) and ground.

2 (SB) - Ground : Continuity should not exist.

3 (V) - Ground : Continuity should not exist.

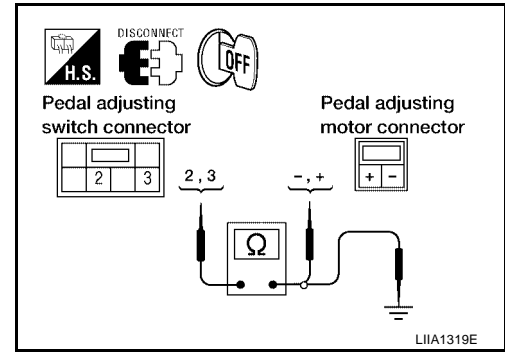

OK or NG

OK >> GO TO 3.

NG >> Repair or replace harness between pedal adjusting switch and pedal adjusting motor.

3. CHECK PEDAL ADJUSTING MOTOR POWER SUPPLY

1. Connect pedal adjusting switch.
2. Check voltage between pedal adjusting motor and ground.

Connector	Terminal (Wire color)		Condition	Voltage (V) (Approx.)
	(+)	(-)		
M14	+ (G)	Ground	Pedal adjusting switch forward	Battery voltage
			Other than above	0
	- (R)		Pedal adjusting switch backward	Battery voltage
			Other than above	0

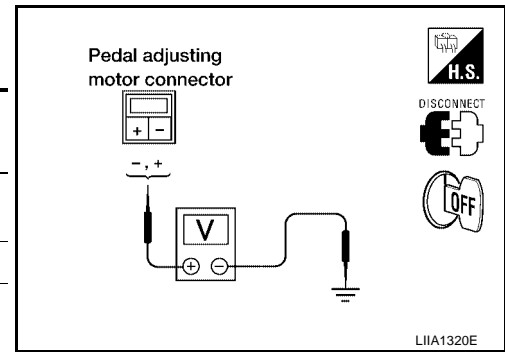

OK or NG

OK >> Replace pedal adjusting motor. Refer to [AP-15, "Removal and Installation"](#).

NG >> Repair or replace harness.

ADJUSTABLE PEDAL SYSTEM

Removal and Installation

EIS0020X

Refer to [ACC-2, "ACCELERATOR CONTROL SYSTEM"](#) and [BR-6, "BRAKE PEDAL"](#) .

A

B

C

D

E

F

G

H

AP

J

K

L

M

ADJUSTABLE PEDAL SYSTEM
