

SECTION **RAX**
REAR AXLE

A
B
C

RAX

CONTENTS

E

PRECAUTIONS	2	WHEEL HUB	5	
Precautions for Supplemental Restraint System (SRS) "AIR BAG" and "SEAT BELT PRE-TENSIONER"	2	On-Vehicle Inspection and Service	5	F
Precautions for Rear Axle	2	REAR WHEEL BEARING	5	
PREPARATION	3	Removal and Installation	6	G
Commercial Service Tools	3	REMOVAL	6	
NOISE, VIBRATION, AND HARSHNESS (NVH)		INSPECTION AFTER REMOVAL	7	H
TROUBLESHOOTING	4	INSTALLATION	7	
NVH Troubleshooting Chart	4	INSPECTION AFTER INSTALLATION	7	H
		SERVICE DATA AND SPECIFICATIONS (SDS)	8	
		Wheel Bearing (Rear)	8	I

I

J

K

L

M

PRECAUTIONS

PRECAUTIONS

PF0:00001

Precautions for Supplemental Restraint System (SRS) “AIR BAG” and “SEAT BELT PRE-TENSIONER”

EDS003R3

The Supplemental Restraint System such as “AIR BAG” and “SEAT BELT PRE-TENSIONER”, used along with a front seat belt, helps to reduce the risk or severity of injury to the driver and front passenger for certain types of collision. This system includes seat belt switch inputs and dual stage front air bag modules. The SRS system uses the seat belt switches to determine the front air bag deployment, and may only deploy one front air bag, depending on the severity of a collision and whether the front occupants are belted or unbelted. Information necessary to service the system safely is included in the SRS and SB section of this Service Manual.

WARNING:

- To avoid rendering the SRS inoperative, which could increase the risk of personal injury or death in the event of a collision which would result in air bag inflation, all maintenance must be performed by an authorized NISSAN/INFINITI dealer.
- Improper maintenance, including incorrect removal and installation of the SRS, can lead to personal injury caused by unintentional activation of the system. For removal of Spiral Cable and Air Bag Module, see the SRS section.
- Do not use electrical test equipment on any circuit related to the SRS unless instructed to in this Service Manual. SRS wiring harnesses can be identified by yellow and/or orange harnesses or harness connectors.

Precautions for Rear Axle

EDS00357

CAUTION:

- When installing each rear suspension rubber component, the final fastener tightening must be carried out with the vehicle under unladen condition* with the tires on the ground.
*Fuel, engine coolant and engine oil full. Spare tire, jack, hand tools, and floor mats in designated positions.
- After installing suspension components, check the rear wheel alignment.
- Do not jack up the vehicle at the rear suspension components.

PREPARATION

PREPARATION

PF0:00002

Commercial Service Tools

EDS00358

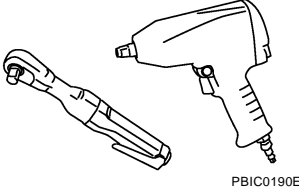
Tool name	Description
<p data-bbox="162 298 272 323">Power tool</p>  <p data-bbox="852 499 922 514">PBIC0190E</p>	<p data-bbox="1015 298 1409 323">Loosening and removing bolts and nuts</p>

A

B

C

RAX

E

F

G

H

I

J

K

L

M

NOISE, VIBRATION, AND HARSHNESS (NVH) TROUBLESHOOTING

NOISE, VIBRATION, AND HARSHNESS (NVH) TROUBLESHOOTING

PF0:00003

NVH Troubleshooting Chart

EDS00359

Use the chart below to help you find the cause of the symptom. If necessary, repair or replace these parts.

Reference page		RAX-6	RAX-5	RAX-5	WT-5, "NVH Troubleshooting Chart"	BR-5, "NVH Troubleshooting Chart" (brakes) PB-4, "On-Vehicle Service" (parking brake)	RSU-4, "NVH Troubleshooting Chart"	WT-5, "NVH Troubleshooting Chart"
Possible cause and SUSPECTED PARTS		Improper installation, looseness	Parts interference	Wheel bearing damage	TIRES	BRAKES	REAR SUSPENSION	ROAD WHEEL
Symptom	Noise	x	x		x	x	x	x
	Shake	x	x		x		x	x
	Vibration	x	x		x	x	x	
	Shimmy	x	x		x		x	x
	Shudder	x			x	x	x	x
	Poor quality ride or handling	x	x	x	x		x	x

x: Applicable

WHEEL HUB

WHEEL HUB

PF:43202

On-Vehicle Inspection and Service

EDS0035A

Check the axle and suspension parts for excessive play, wear, or damage.

- Shake each rear wheel to check for excessive play.

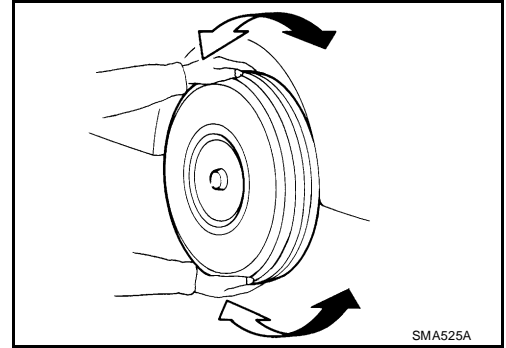

REAR WHEEL BEARING

- Check that the wheel hub bearing axial end play is within specification as shown.

Axial end play : 0.05 mm (0.002 in) or less

- Check that the wheel hub bearing operates smoothly.
- Replace the wheel hub assembly if the axial end play exceeds specification, or if the wheel bearing does not turn smoothly. Refer to [RAX-6, "Removal and Installation"](#).

CAUTION:

The wheel hub assembly does not require maintenance. If any of the following symptoms are noted, replace the wheel hub assembly.

- Growling noise is emitted from the wheel hub bearing during operation.
- Wheel hub bearing drags or turns roughly.

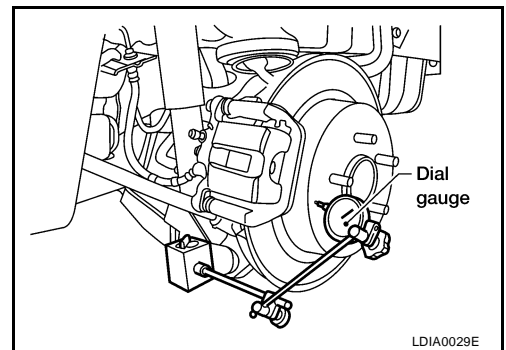

A
B
C
RAX
E
F
G
H
I
J
K
L
M

WHEEL HUB

EDS0035B

Removal and Installation

Rear Wheel Hub Assembly

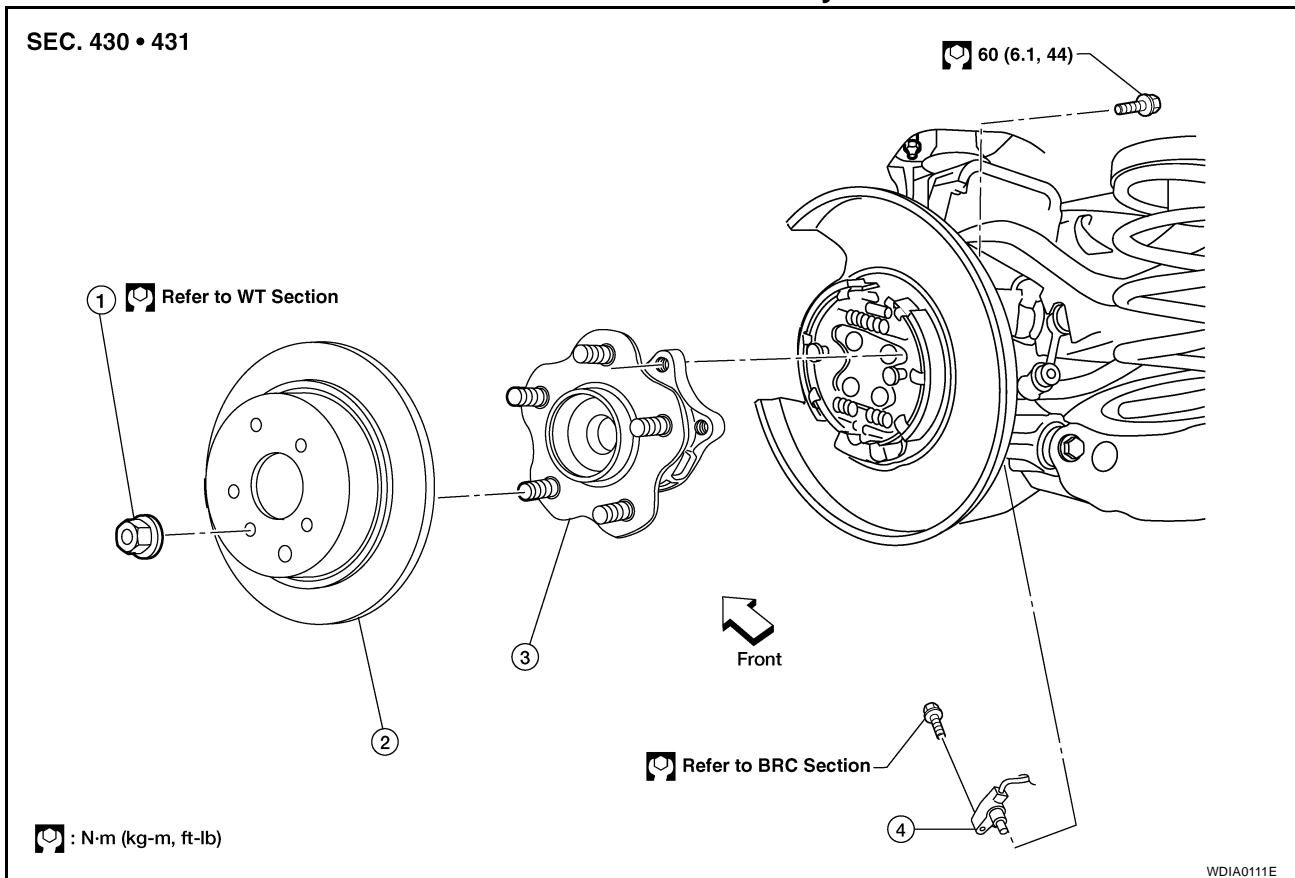

1. Wheel nut
2. Brake rotor
3. Wheel hub assembly
4. Rear ABS sensor

REMOVAL

1. Remove the rear wheel and tire using power tool.
2. Reposition the cylinder body assembly out of the way using a suitable wire without disconnecting the hydraulic hose. Refer to [BR-35, "Removal and Installation of Caliper Assembly and Disc Rotor"](#).
 - The brake hose should not be disconnected from the cylinder body.
 - Suspend the cylinder body assembly using a suitable wire so that the brake hose is not stretched.

CAUTION:

- Do not depress brake pedal, piston will pop out with cylinder body removed.
- Do not twist the brake hose.

3. Remove the brake rotor.

NOTE:

The parking brake must be fully released.

4. Remove the rear ABS sensor, then position it away from the hub assembly using wire. Refer to [BRC-42, "WHEEL SENSORS"](#) (TCS/ABS), [BRC-94, "WHEEL SENSORS"](#) (VDC/TCS/ABS).

CAUTION:

- Failure to remove the rear ABS sensor may result in damage to the sensor, causing the sensor to become inoperative.
- Do not stretch the rear ABS sensor wire harness.

5. Remove the wheel hub assembly from the knuckle using power tool.

WHEEL HUB

INSPECTION AFTER REMOVAL

Check for deformity, cracks, and damage on the wheel hub assembly, replace if necessary.

CAUTION:

The wheel hub assembly does not require maintenance. If any of the following symptoms are noted, replace the wheel hub assembly.

- Growling noise is emitted from the wheel hub bearing during operation.
- Wheel hub bearing drags or turns roughly.

INSTALLATION

Installation is in the reverse order of removal.

INSPECTION AFTER INSTALLATION

- Check that the wheel bearing operates smoothly.
- Check that the wheel hub bearing axial end play is within specification as shown.

Axial end play : 0.05 mm (0.002 in) or less

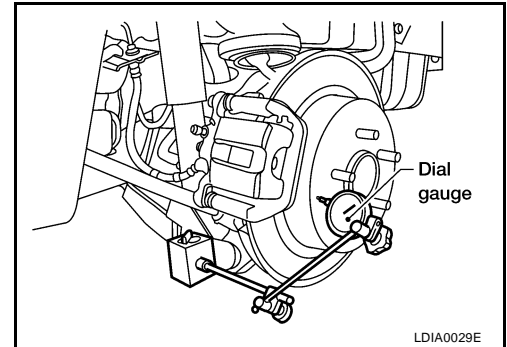

A
B
C

RAX

E
F
G
H
I
J
K
L
M

SERVICE DATA AND SPECIFICATIONS (SDS)

SERVICE DATA AND SPECIFICATIONS (SDS)

PF:00030

Wheel Bearing (Rear)

EDS0035C

Axial end play	0.05 mm (0.002 in) or less
----------------	----------------------------
