

SECTION PG

POWER SUPPLY, GROUND & CIRCUIT ELEMENTS

CONTENTS

<p>PRECAUTIONS 3</p> <p> Precautions for Supplemental Restraint System (SRS) "AIR BAG" and "SEAT BELT PRE-TENSIONER" 3</p> <p>POWER SUPPLY ROUTING CIRCUIT 4</p> <p> Schematic 4</p> <p> Wiring Diagram — POWER — 6</p> <p> BATTERY POWER SUPPLY — IGNITION SW. IN ANY POSITION 6</p> <p> ACCESSORY POWER SUPPLY — IGNITION SW. IN ACC OR ON 10</p> <p> IGNITION POWER SUPPLY — IGNITION SW. IN ON 11</p> <p> IGNITION POWER SUPPLY — IGNITION SW. IN ON AND/OR START 12</p> <p> Fuse 17</p> <p> Fusible Link 17</p> <p> Circuit Breaker (Built Into BCM) 17</p> <p> Circuit Breaker (PTC) 17</p> <p>IPDM E/R (INTELLIGENT POWER DISTRIBUTION MODULE ENGINE ROOM) 18</p> <p> System Description 18</p> <p> SYSTEMS CONTROLLED BY IPDM E/R 18</p> <p> CAN COMMUNICATION LINE CONTROL 18</p> <p> IPDM E/R STATUS CONTROL 20</p> <p> CAN Communication System Description 20</p> <p> Function of Detecting Ignition Relay Malfunction ... 20</p> <p> CONSULT-II Function (IPDM E/R) 21</p> <p> CONSULT-II START PROCEDURE 21</p> <p> SELF-DIAGNOSTIC RESULTS 21</p> <p> DATA MONITOR 21</p> <p> CAN DIAG SUPPORT MNTR 22</p> <p> ACTIVE TEST 22</p> <p> Auto Active Test 23</p> <p> DESCRIPTION 23</p> <p> OPERATION PROCEDURE 23</p> <p> INSPECTION IN AUTO ACTIVE TEST MODE... 24</p> <p> IPDM E/R Terminal Arrangement 26</p> <p> Terminals and Reference Values for IPDM E/R 27</p> <p> IPDM E/R Power/Ground Circuit Inspection 31</p>	<p> Inspection with CONSULT-II (Self-Diagnosis) 32</p> <p> Removal and Installation of IPDM E/R 33</p> <p> REMOVAL 33</p> <p> INSTALLATION 33</p> <p>GROUND CIRCUIT 34</p> <p> Ground Distribution 34</p> <p> MAIN HARNESS 34</p> <p> ENGINE ROOM HARNESS 36</p> <p> ENGINE CONTROL HARNESS 39</p> <p> BODY HARNESS 40</p> <p> BODY NO. 2 HARNESS 42</p> <p> BACK DOOR NO. 2 HARNESS 43</p> <p>HARNESS 44</p> <p> Harness Layout 44</p> <p> HOW TO READ HARNESS LAYOUT 44</p> <p> OUTLINE 45</p> <p> MAIN HARNESS 46</p> <p> ENGINE ROOM HARNESS (RH VIEW) 49</p> <p> ENGINE ROOM HARNESS (LH VIEW) 53</p> <p> ENGINE CONTROL HARNESS 55</p> <p> BODY HARNESS 57</p> <p> BODY NO. 2 HARNESS 59</p> <p> ROOM LAMP HARNESS 61</p> <p> FRONT DOOR HARNESS LH 63</p> <p> FRONT DOOR HARNESS RH 64</p> <p> SLIDING DOOR HARNESS LH 65</p> <p> SLIDING DOOR HARNESS RH 66</p> <p> BACK DOOR HARNESS 67</p> <p> Wiring Diagram Codes (Cell Codes) 69</p> <p>ELECTRICAL UNITS LOCATION 72</p> <p> Electrical Units Location 72</p> <p> ENGINE COMPARTMENT 72</p> <p> PASSENGER COMPARTMENT 73</p> <p>HARNESS CONNECTOR 76</p> <p> Description 76</p> <p> HARNESS CONNECTOR (TAB-LOCKING TYPE) 76</p> <p> HARNESS CONNECTOR (SLIDE-LOCKING TYPE) 77</p> <p> HARNESS CONNECTOR (LEVER LOCKING</p>
--	---

A
B
C
D
E
F
G
H
I
J
L
M

PG

TYPE)	78	MIXED TYPE RELAYS	81
HARNESS CONNECTOR (DIRECT-CONNECT		TYPE OF STANDARDIZED RELAYS	81
SRS COMPONENT TYPE)	79	SUPER MULTIPLE JUNCTION (SMJ)	83
ELECTRICAL UNITS	80	Terminal Arrangement	83
Terminal Arrangement	80	FUSE BLOCK-JUNCTION BOX (J/B)	84
STANDARDIZED RELAY	81	Terminal Arrangement	84
Description	81	FUSE AND FUSIBLE LINK BOX	85
NORMAL OPEN, NORMAL CLOSED AND		Terminal Arrangement	85

PRECAUTIONS

PRECAUTIONS

PFP:00011

Precautions for Supplemental Restraint System (SRS) “AIR BAG” and “SEAT BELT PRE-TENSIONER”

EKS00F0N

The Supplemental Restraint System such as “AIR BAG” and “SEAT BELT PRE-TENSIONER”, used along with a front seat belt, helps to reduce the risk or severity of injury to the driver and front passenger for certain types of collision. This system includes seat belt switch inputs and dual stage front air bag modules. The SRS system uses the seat belt switches to determine the front air bag deployment, and may only deploy one front air bag, depending on the severity of a collision and whether the front occupants are belted or unbelted. Information necessary to service the system safely is included in the SRS and SB section of this Service Manual.

WARNING:

- To avoid rendering the SRS inoperative, which could increase the risk of personal injury or death in the event of a collision which would result in air bag inflation, all maintenance must be performed by an authorized NISSAN/INFINITI dealer.
- Improper maintenance, including incorrect removal and installation of the SRS, can lead to personal injury caused by unintentional activation of the system. For removal of Spiral Cable and Air Bag Module, see the SRS section.
- Do not use electrical test equipment on any circuit related to the SRS unless instructed to in this Service Manual. SRS wiring harnesses can be identified by yellow and/or orange harnesses or harness connectors.

A

B

C

D

E

F

G

H

I

J

PG

L

M

POWER SUPPLY ROUTING CIRCUIT

(MD) : WITH MIRROR DEFOGGER

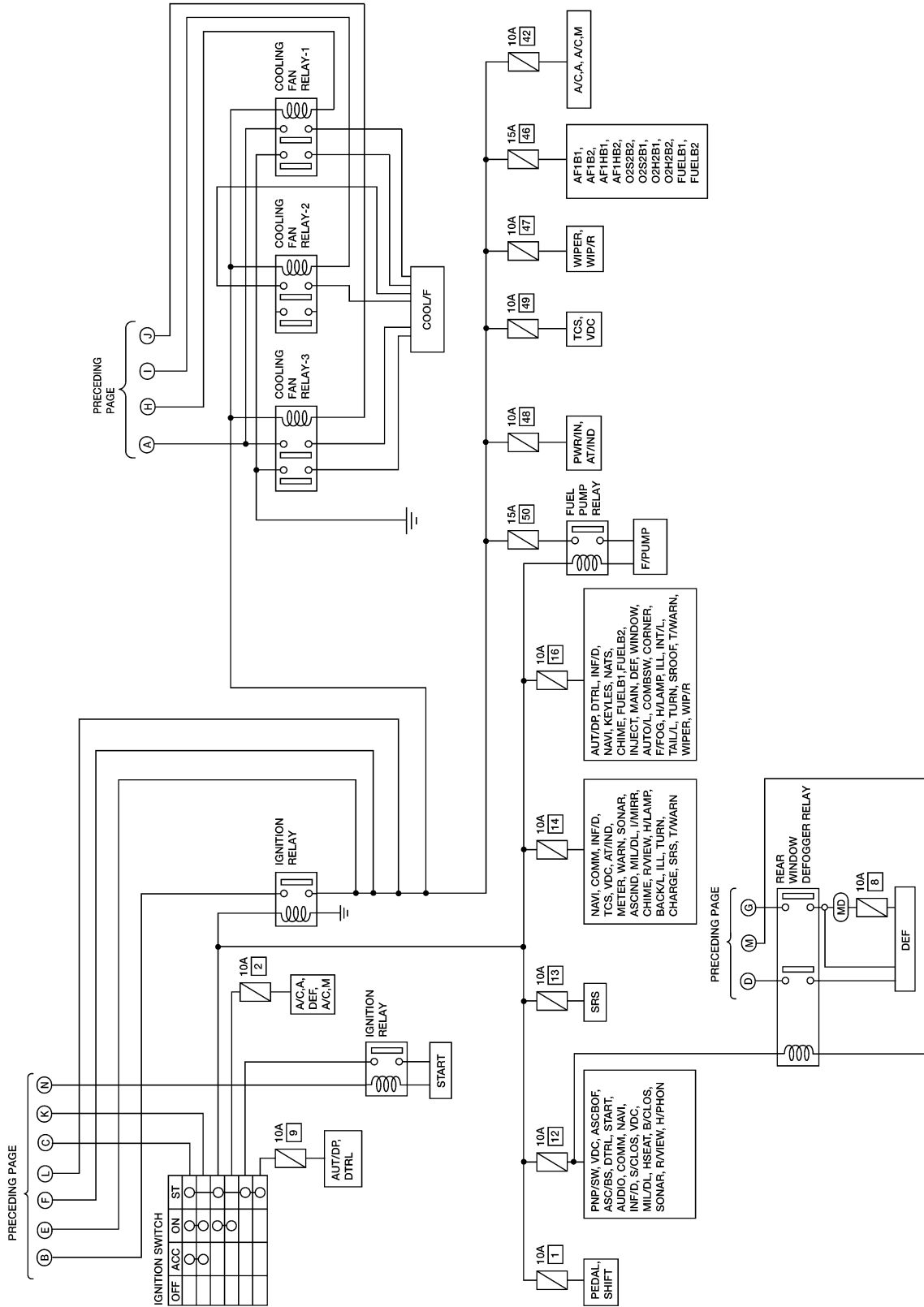

WKWA4810E

A
B
C
D
E
F
G
H
I
J
L
M

PG

POWER SUPPLY ROUTING CIRCUIT

EKS00FOO

Wiring Diagram — POWER — BATTERY POWER SUPPLY — IGNITION SW. IN ANY POSITION

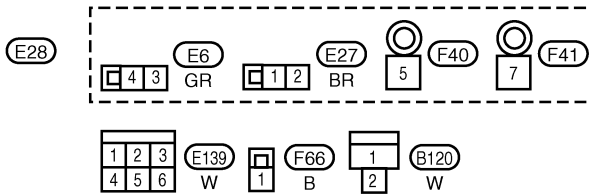
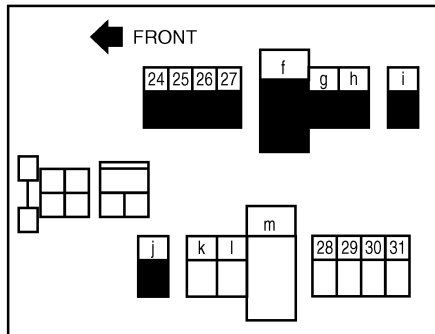
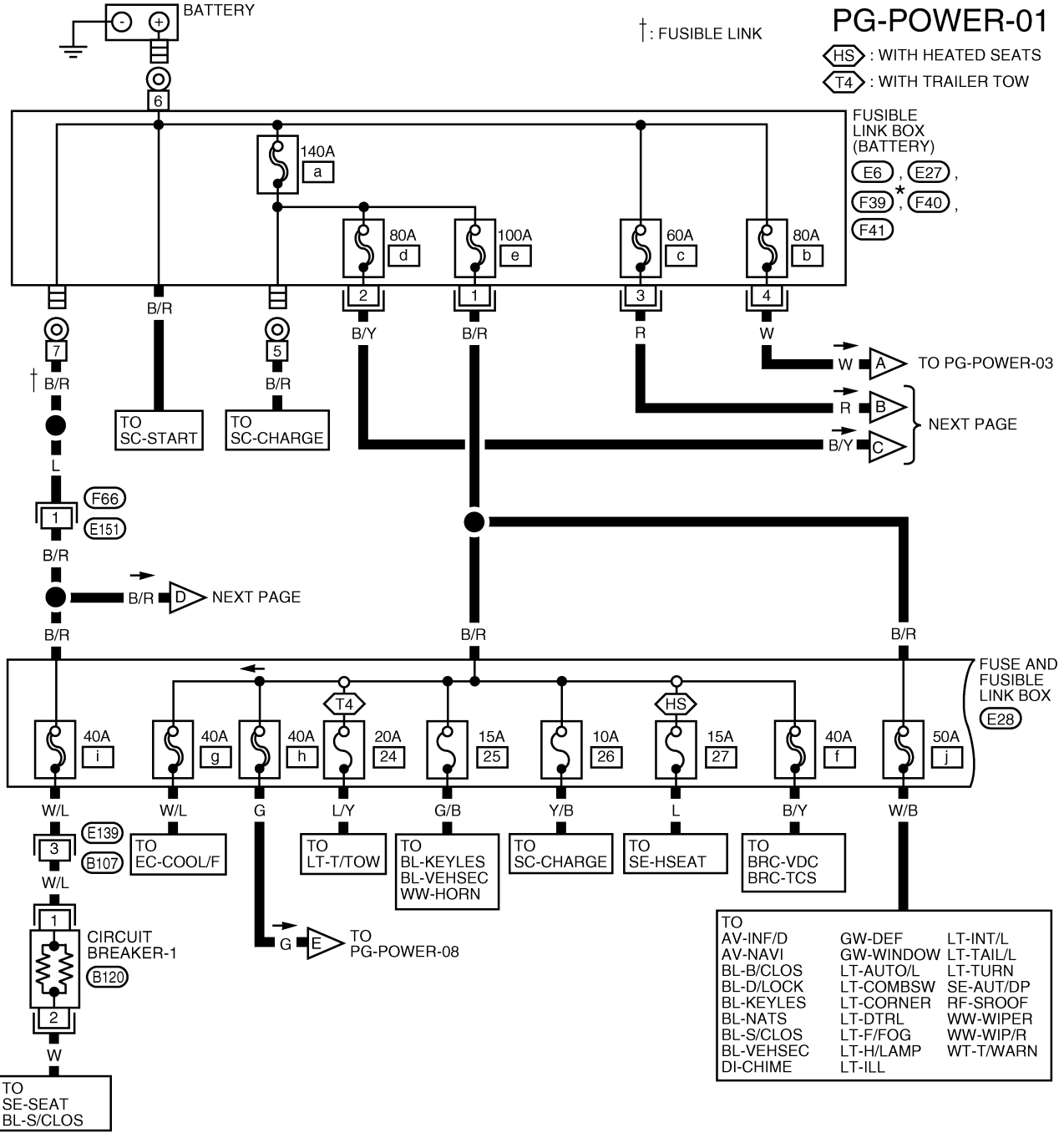

*: (F39) IS AN INTEGRAL PART OF FUSIBLE LINK BOX (BATTERY) ASSEMBLY.

WKWA4811E

POWER SUPPLY ROUTING CIRCUIT

PG-POWER-02

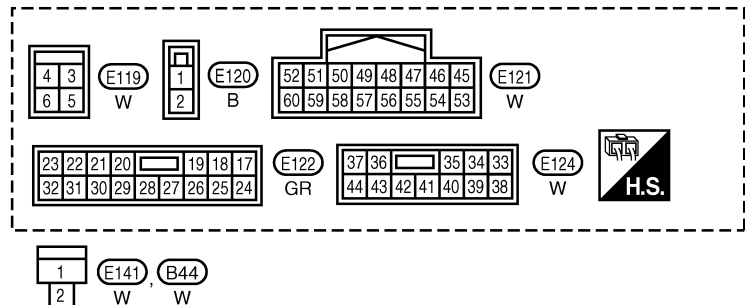
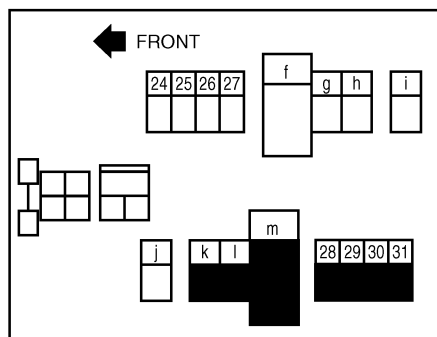
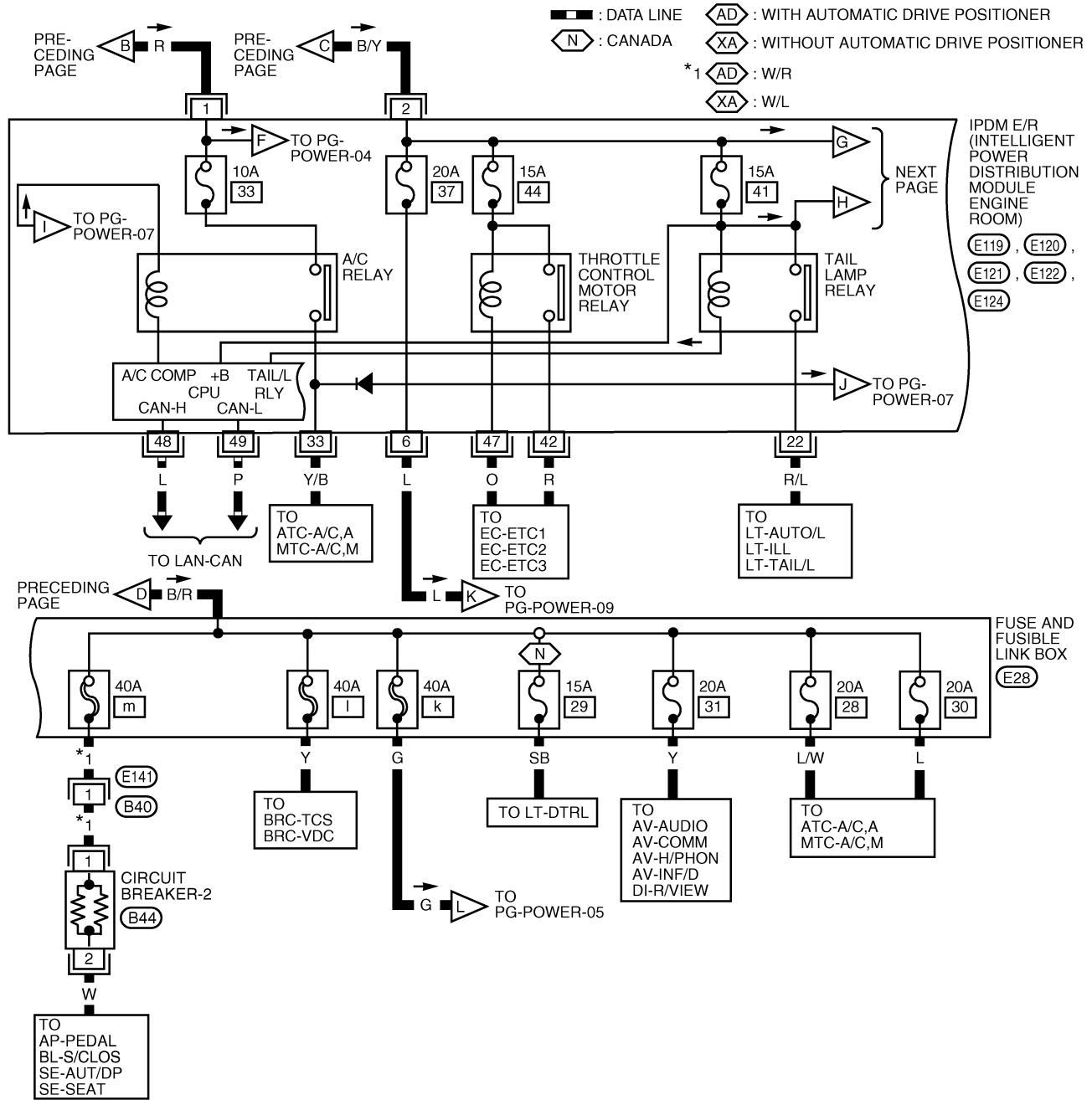

WKWA4812E

POWER SUPPLY ROUTING CIRCUIT

PG-POWER-03

FL : WITH FRONT FOG LAMPS

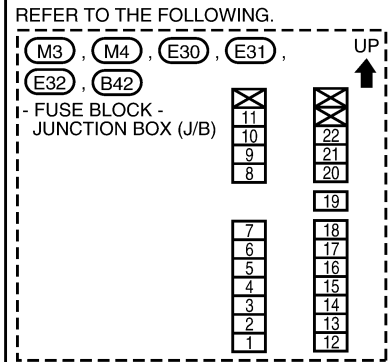
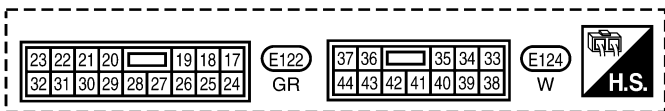
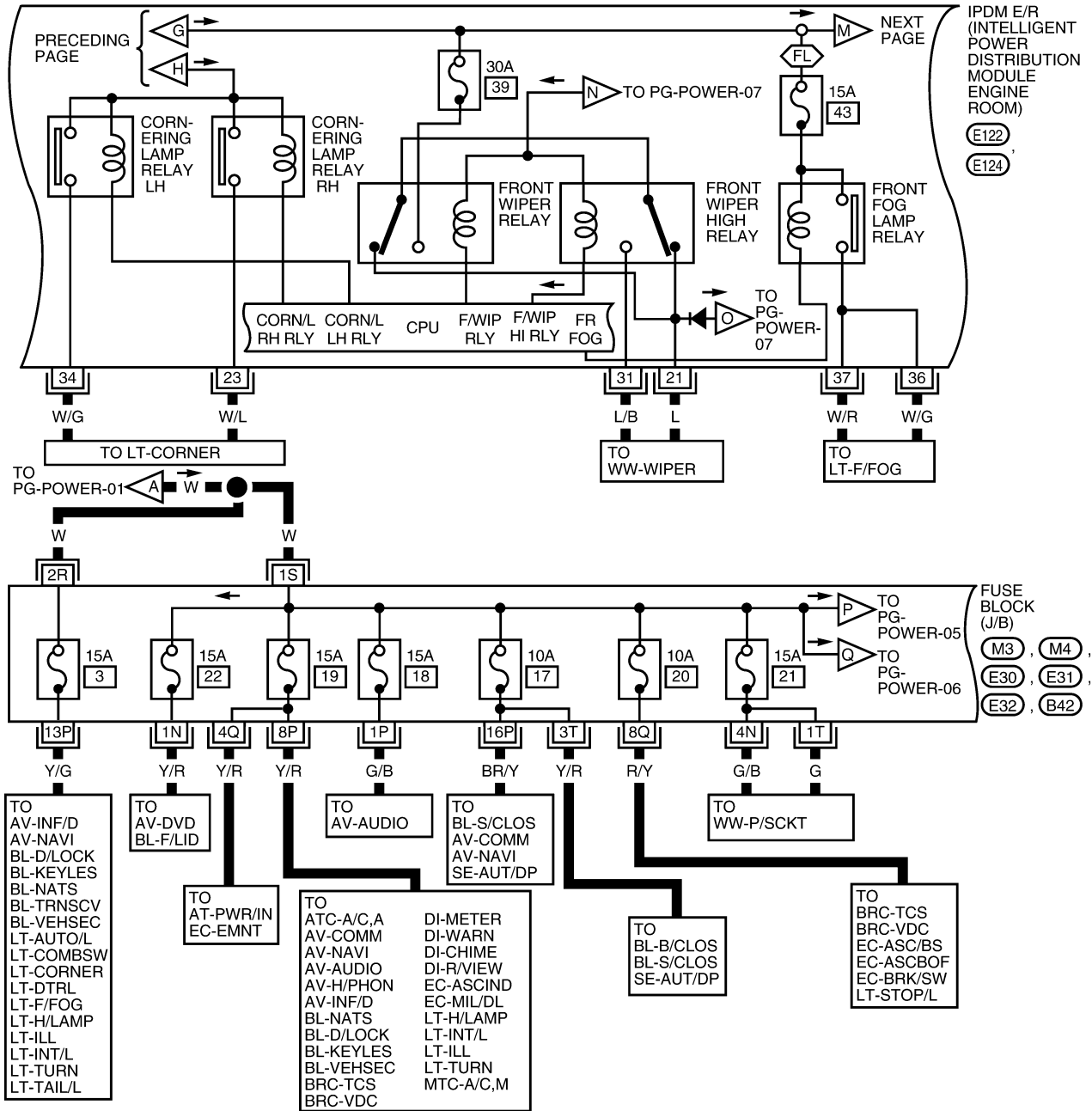

WKWA4813E

POWER SUPPLY ROUTING CIRCUIT

PG-POWER-04

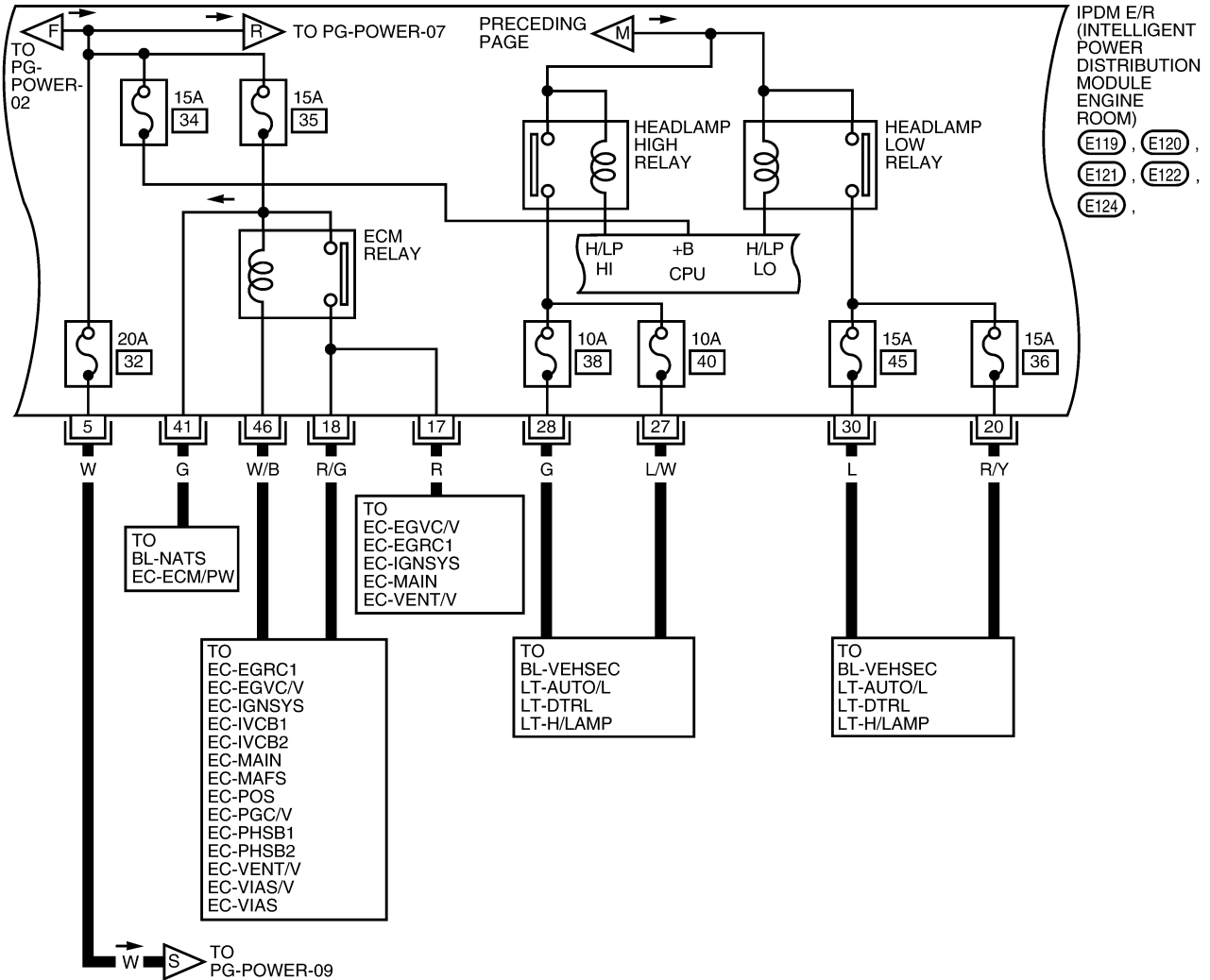

A
B
C
D
E
F
G
H
I
J
PG
L
M

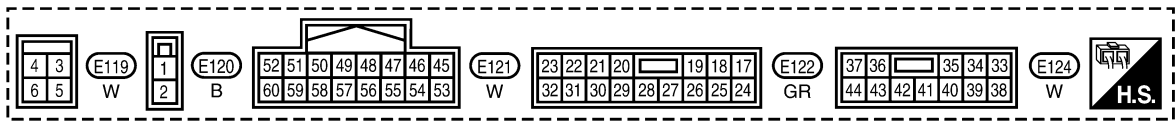

WKWA4814E

POWER SUPPLY ROUTING CIRCUIT

ACCESSORY POWER SUPPLY — IGNITION SW. IN ACC OR ON

PG-POWER-05

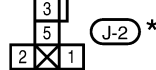
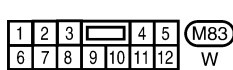
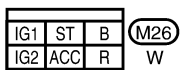
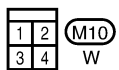
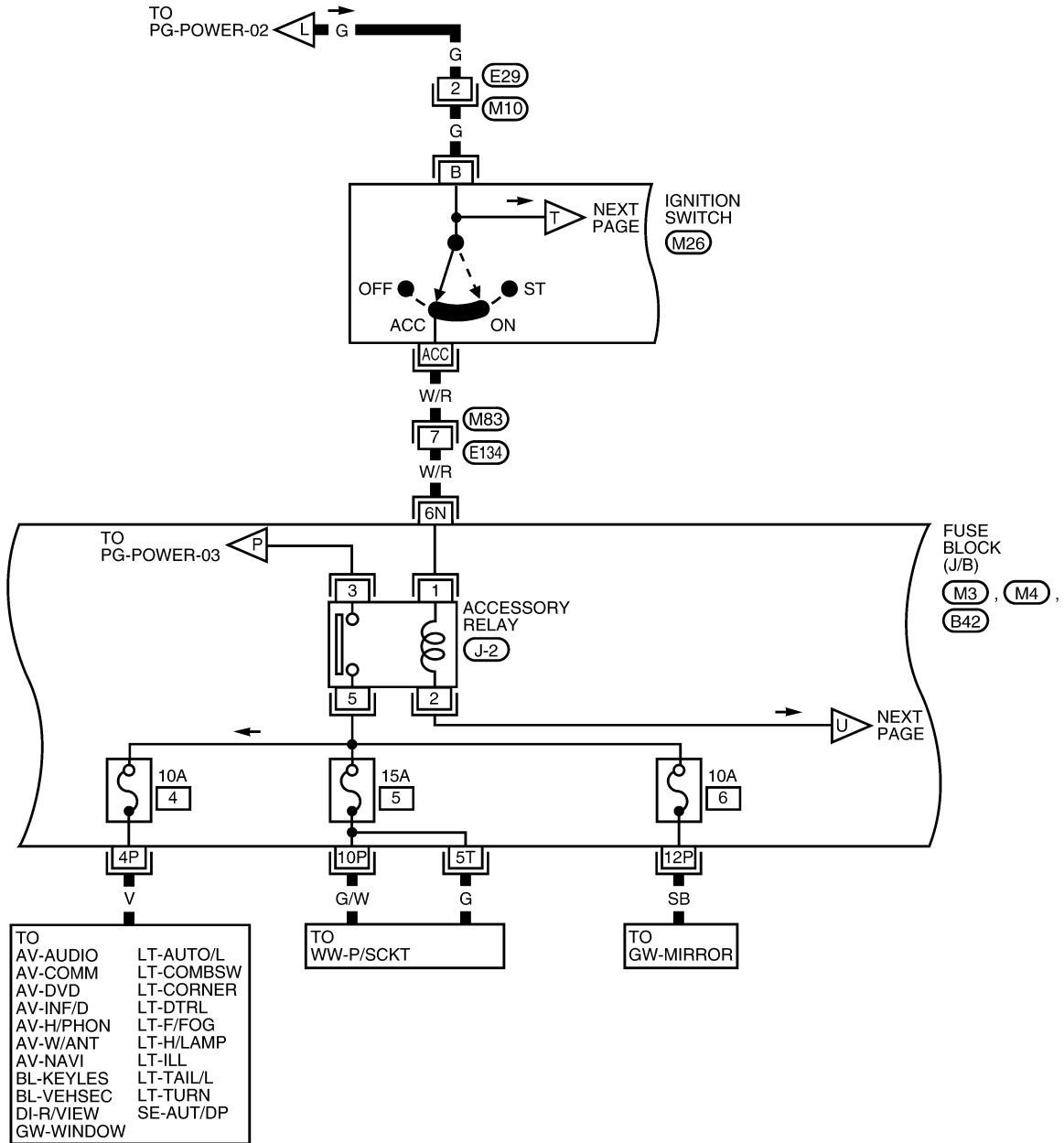

* : THIS CONNECTOR IS NOT SHOWN IN "HARNESS LAYOUT".

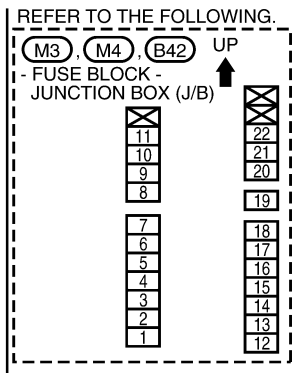

WKWA4815E

POWER SUPPLY ROUTING CIRCUIT

IGNITION POWER SUPPLY — IGNITION SW. IN ON

PG-POWER-06

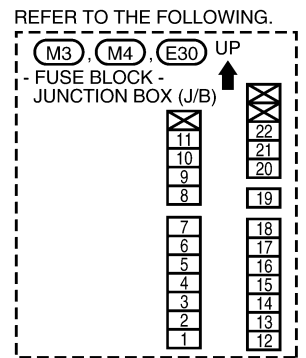
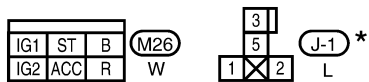
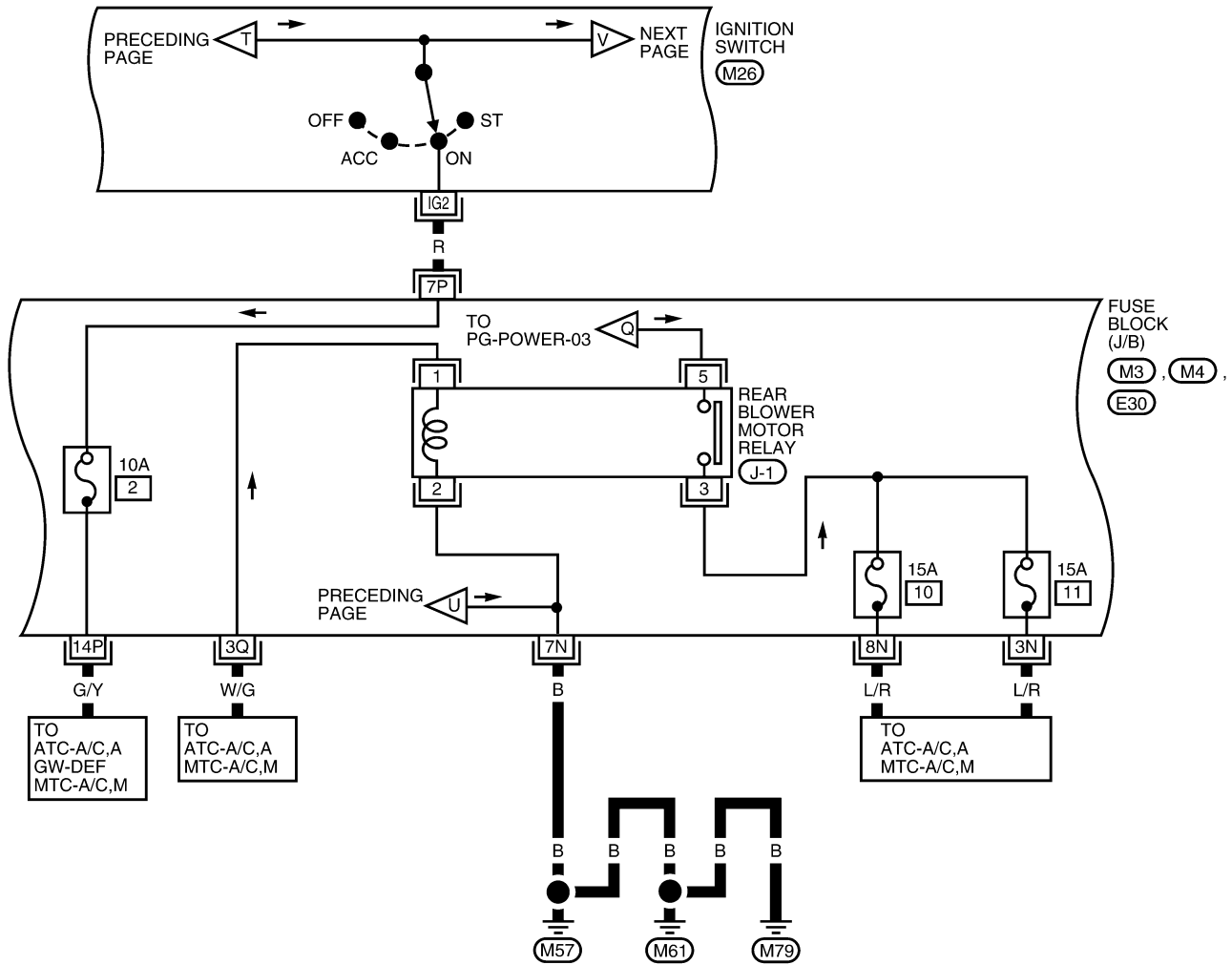

*: THIS CONNECTOR IS NOT SHOWN IN "HARNESS LAYOUT".

WKWA4816E

POWER SUPPLY ROUTING CIRCUIT

IGNITION POWER SUPPLY — IGNITION SW. IN ON AND/OR START

PG-POWER-07

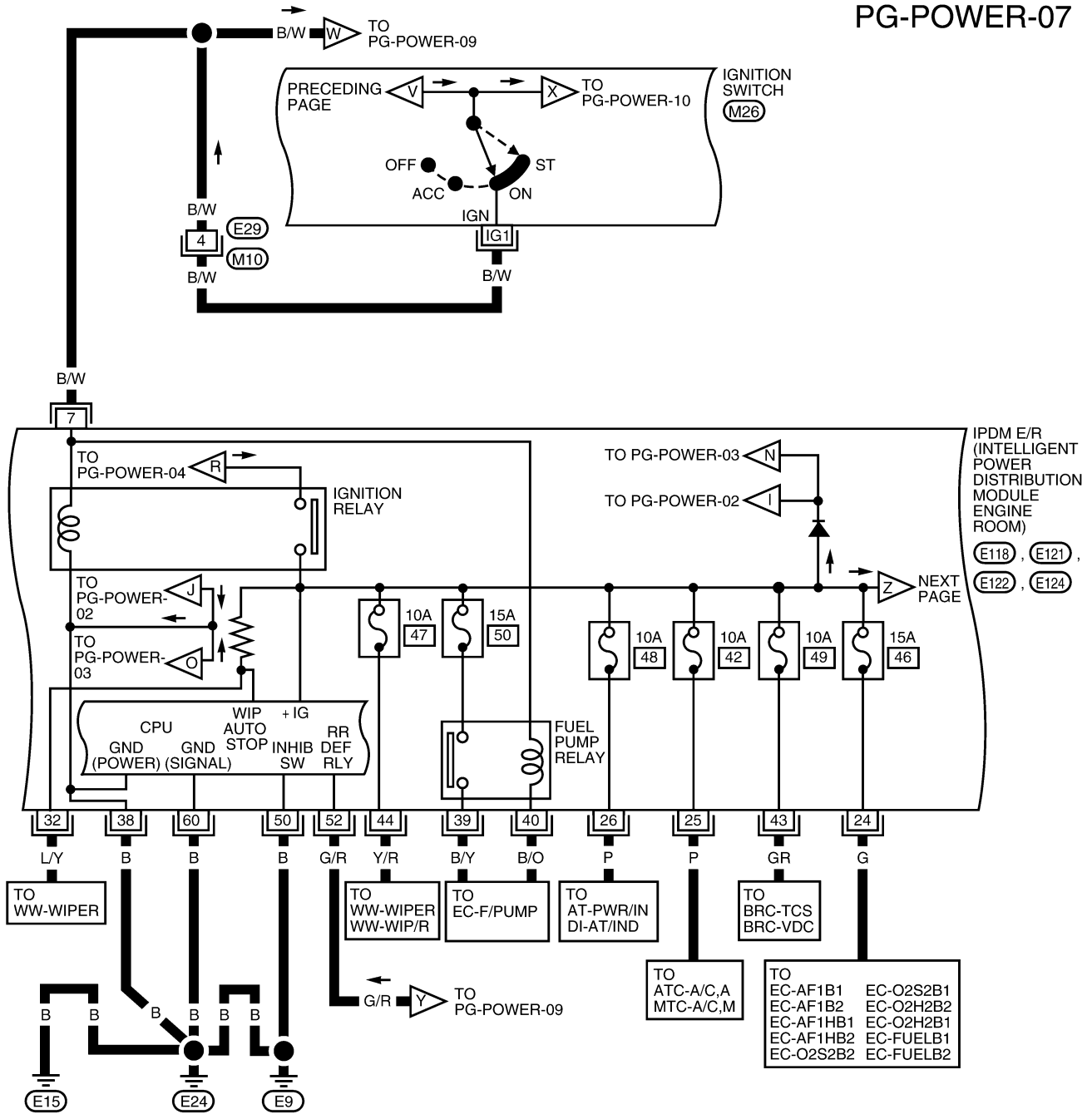

IPDM E/R
(INTELLIGENT
POWER
DISTRIBUTION
MODULE
ENGINE
ROOM)
E118, E121,
E122, E124

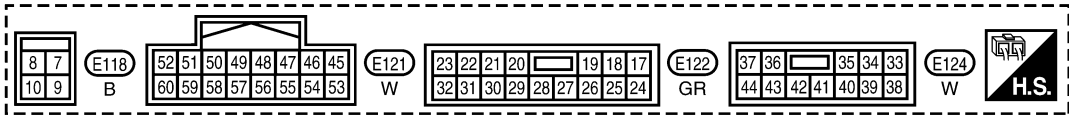

WKWA4817E

POWER SUPPLY ROUTING CIRCUIT

PG-POWER-08

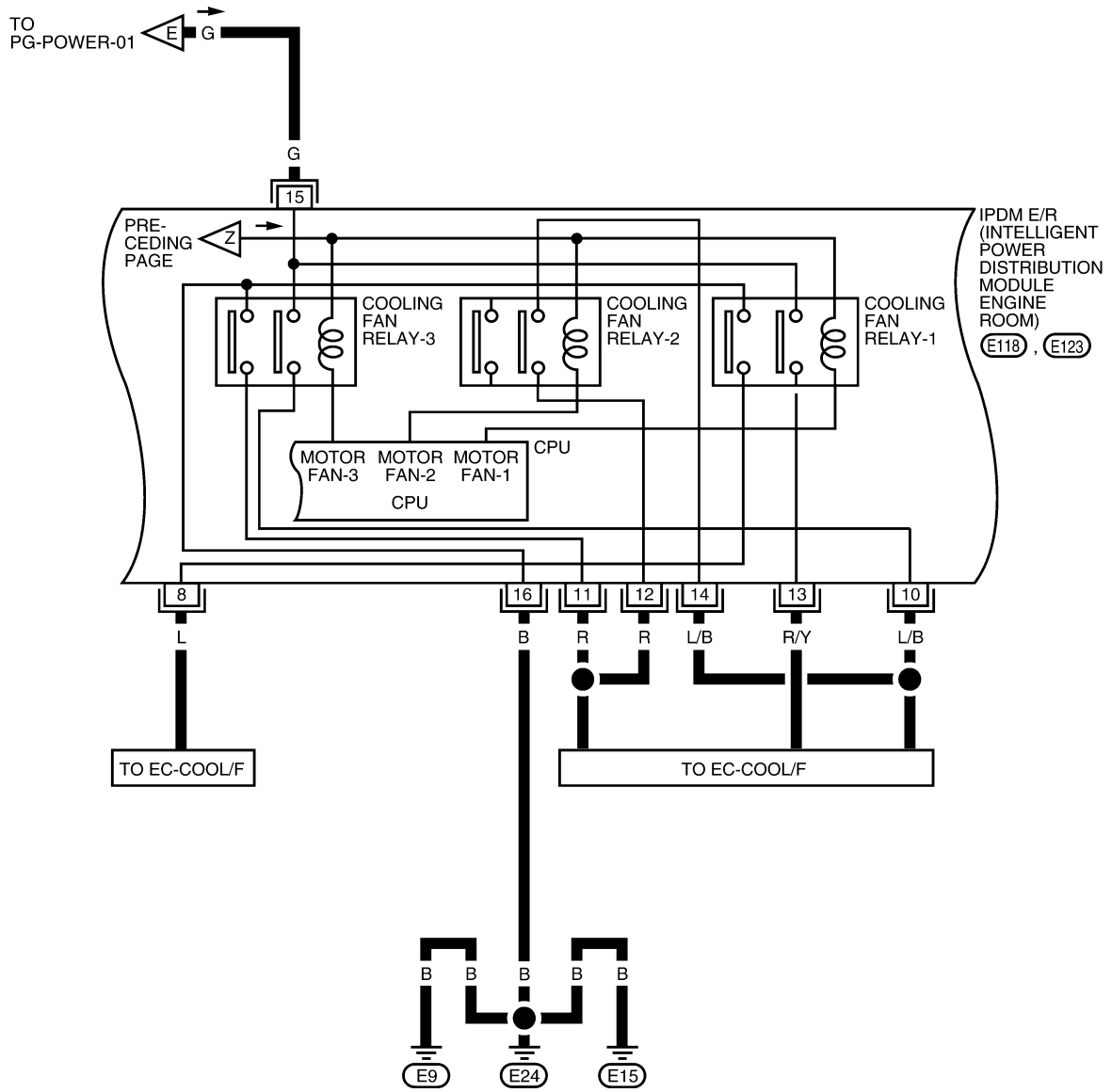

A
B
C
D
E
F
G
H
I
J
L
M

PG

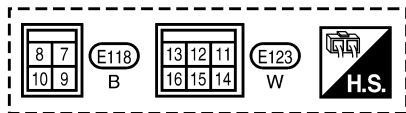

WKWA4818E

POWER SUPPLY ROUTING CIRCUIT

PG-POWER-09

MD : WITH MIRROR DEFOGGER

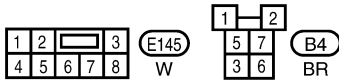
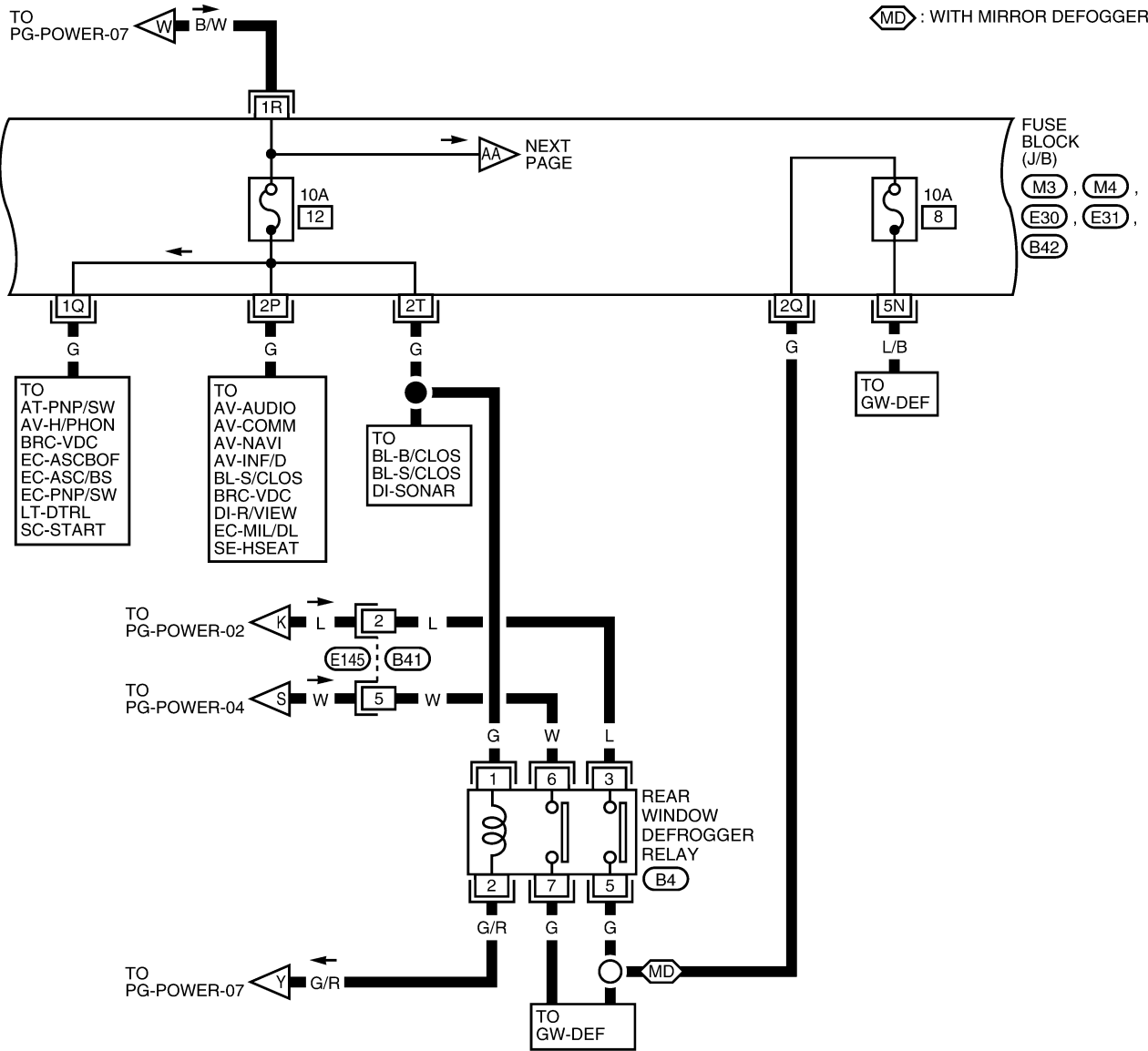

REFER TO THE FOLLOWING.

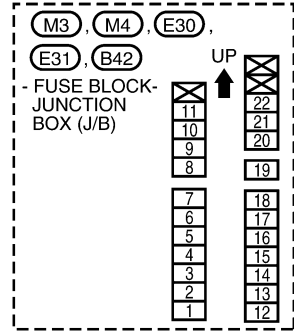

WKWA4819E

POWER SUPPLY ROUTING CIRCUIT

PG-POWER-10

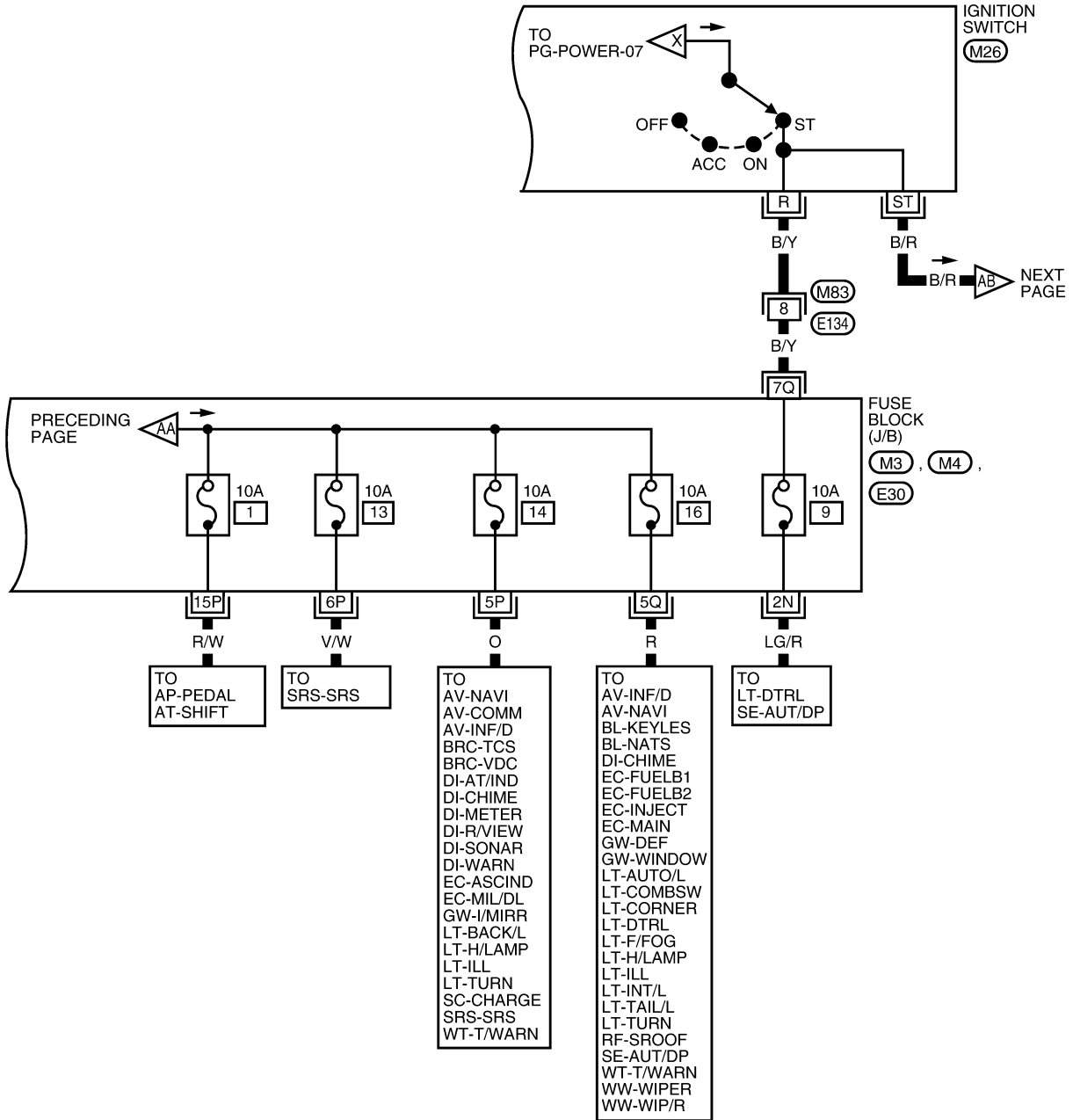

IG1	ST	B	M26
IG2	ACC	R	W

1	2	3	4	5	M83		
6	7	8	9	10	11	12	W

REFER TO THE FOLLOWING.

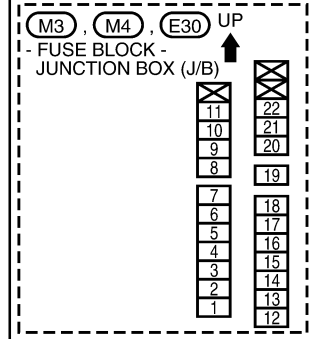

WKWA4820E

POWER SUPPLY ROUTING CIRCUIT

PG-POWER-11

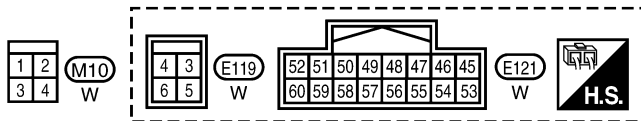
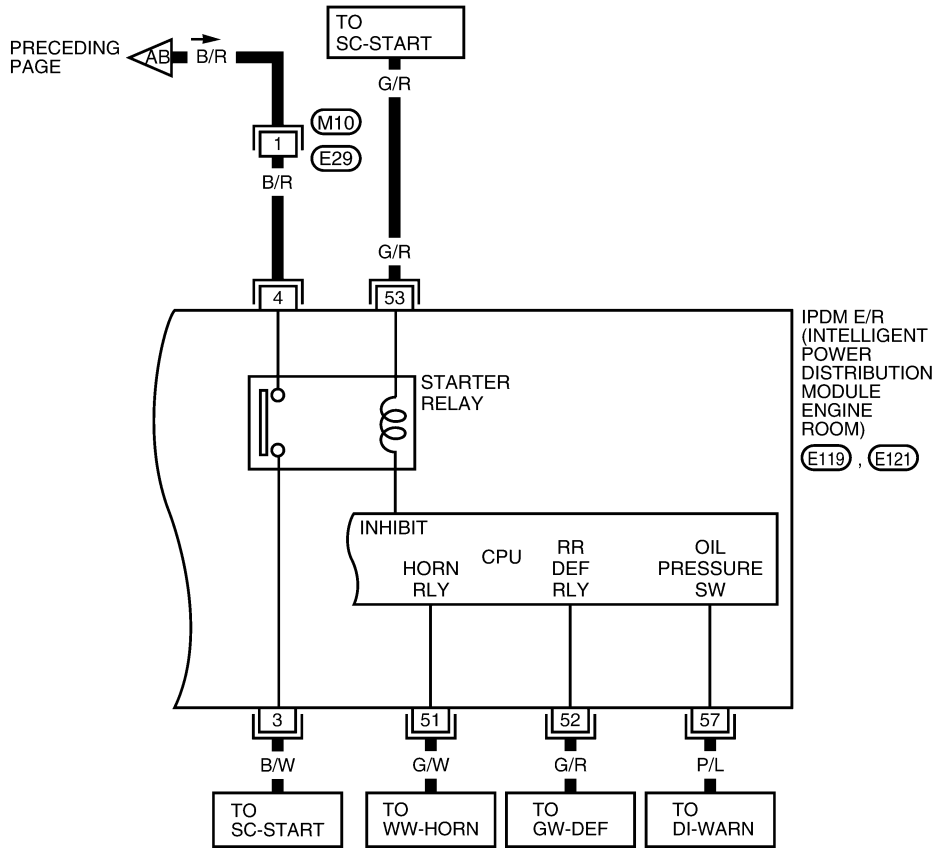

WKWA4944E

POWER SUPPLY ROUTING CIRCUIT

Fuse

EKS00GAA

- If fuse is blown, be sure to eliminate cause of incident before installing new fuse.
- Use fuse of specified rating. Never use fuse of more than specified rating.
- Do not partially install fuse, always insert it into fuse holder properly.
- Remove fuse for "ELECTRICAL PARTS (BAT)" if vehicle is not used for a long period of time.

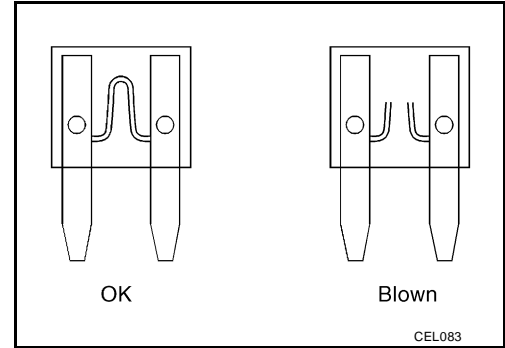

Fusible Link

EKS00GAB

A melted fusible link can be detected either by visual inspection or by feeling with finger tip. If its condition is questionable, use circuit tester or test lamp.

CAUTION:

- If fusible link should melt, it is possible that critical circuit (power supply or large current carrying circuit) is shorted. In such a case, carefully check and eliminate cause of incident.
- Never wrap outside of fusible link with vinyl tape.
- Never let fusible link touch any other wiring harness, vinyl or rubber parts.

Circuit Breaker (Built Into BCM)

EKS00GAC

For example, when current is 30A, the circuit is broken within 8 to 20 seconds.

A circuit breaker is used for the following systems:

- Power windows
- Power sunroof

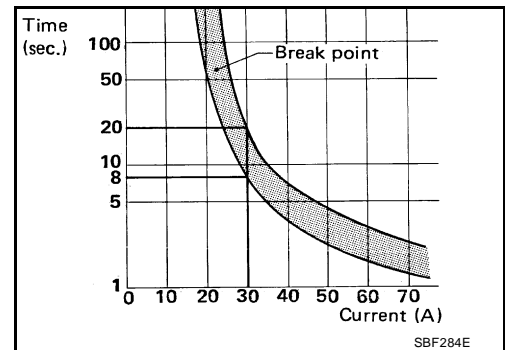

Circuit Breaker (PTC)

EKS00IBK

The PTC thermistor generates heat in response to current flow. The temperature (and resistance) of the thermistor element varies with current flow. Excessive current flow will cause the element's temperature to rise. When the temperature reaches a specified level, the electrical resistance will rise sharply to reduce the circuit current. This reduced current flow will cause the element to cool lowering the resistance accordingly. Once resistance falls to a specified level normal circuit current flow is allowed to resume.

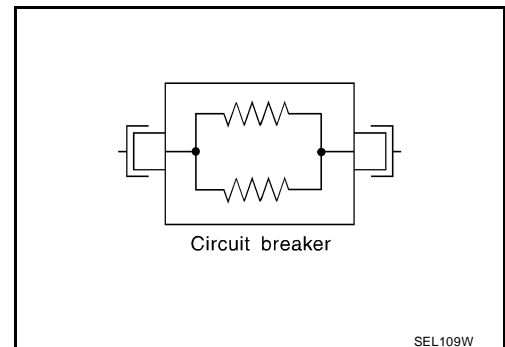

IPDM E/R (INTELLIGENT POWER DISTRIBUTION MODULE ENGINE ROOM)

IPDM E/R (INTELLIGENT POWER DISTRIBUTION MODULE ENGINE ROOM)

PF0:284B7

System Description

EKS00FOR

- IPDM E/R (Intelligent Power Distribution Module Engine Room) integrates the relay box and fuse block which were originally placed in engine compartment. It controls integrated relays via IPDM E/R control circuits.
- IPDM E/R-integrated control circuits perform ON-OFF operation of relays, CAN communication control, oil pressure switch signal reception, etc.
- It controls operation of each electrical component via ECM, BCM and CAN communication lines.

CAUTION:

None of the IPDM E/R integrated relays can be removed.

SYSTEMS CONTROLLED BY IPDM E/R

1. Lamp control
Using CAN communication lines, it receives signals from the BCM and controls the following lamps:
 - Headlamps (High, Low)
 - Parking lamps
 - Tail and license plate lamps
 - Cornering lamps
 - Front fog lamps
2. Wiper control
Using CAN communication lines, it receives signals from the BCM and controls the front wipers.
3. Rear window defogger relay control
Using CAN communication lines, it receives signals from the BCM and controls the rear window defogger relay.
4. A/C compressor control
Using CAN communication lines, it receives signals from the ECM and controls the A/C compressor (magnet clutch).
5. Starter control
Using CAN communication lines, it receives signals from the BCM and controls the starter relay.
6. Cooling fan control
Using CAN communication lines, it receives signals from the ECM and controls the cooling fan relays.
7. Horn control
Using CAN communication lines, it receives signals from the BCM and controls the horn relay.

CAN COMMUNICATION LINE CONTROL

With CAN communication, by connecting each control unit using two communication lines (CAN L-line, CAN H-line), it is possible to transmit a maximum amount of information with minimum wiring. Each control unit can transmit and receive data, and reads necessary information only.

1. Fail-safe control
 - When CAN communication with other control units is impossible, IPDM E/R performs fail-safe control. After CAN communication returns to normal operation, it also returns to normal control.
 - Operation of control parts by IPDM E/R during fail-safe mode is as follows:

Controlled system	Fail-safe mode
Headlamp	<ul style="list-style-type: none">● With the ignition switch ON, the headlamp (low relay) is ON.● With the ignition switch OFF, the headlamp (low relay) is OFF.
Tail, license plate and parking lamps	<ul style="list-style-type: none">● With the ignition switch ON, the tail lamp relay is ON.● With the ignition switch OFF, the tail lamp relay is OFF.
Cooling fan	<ul style="list-style-type: none">● With the ignition switch ON, the cooling fan HI relay is ON.● With the ignition switch OFF, the cooling fan relays are OFF.
Front wiper	Until the ignition switch is turned off, the front wiper relays remain in the same status they were in just before fail-safe control was initiated.
Rear window defogger	Rear window defogger relay OFF

IPDM E/R (INTELLIGENT POWER DISTRIBUTION MODULE ENGINE ROOM)

Controlled system	Fail-safe mode
A/C compressor	A/C relay is OFF
Front fog lamps	Front fog lamp relay OFF

A

B

C

D

E

F

G

H

I

J

PG

L

M

IPDM E/R (INTELLIGENT POWER DISTRIBUTION MODULE ENGINE ROOM)

IPDM E/R STATUS CONTROL

In order to save power, IPDM E/R switches status by itself based on each operating condition.

1. CAN communication status
 - CAN communication is normally performed with other control units.
 - Individual unit control by IPDM E/R is normally performed.
 - When sleep request signal is received from BCM, mode is switched to sleep waiting status.
2. Sleep waiting status
 - Process to stop CAN communication is activated.
 - All systems controlled by IPDM E/R are stopped. When 1 second has elapsed after CAN communication with other control units is stopped, mode switches to sleep status.
3. Sleep status
 - IPDM E/R operates in low current-consumption mode.
 - CAN communication is stopped.
 - When a change in CAN communication signal is detected, mode switches to CAN communication status.
 - When a change in ignition switch signal is detected, mode switches to CAN communication status.

CAN Communication System Description

EKS00F0S

Refer to [LAN-4, "SYSTEM DESCRIPTION"](#) .

Function of Detecting Ignition Relay Malfunction

EKS00F0T

- When the integrated ignition relay is stuck in a "closed contact" position and cannot be turned OFF, IPDM E/R turns ON tail and parking lamps for 10 minutes to indicate IPDM E/R malfunction.
- When the state of the integrated ignition relay does not agree with the state of the ignition switch signal received via CAN communication, the IPDM E/R activates the tail lamp relay.

Ignition switch signal	Ignition relay status	Tail lamp relay
ON	ON	—
OFF	OFF	—
ON	OFF	—
OFF	ON	ON (10 minutes)

NOTE:

When the ignition switch is turned ON, the tail lamps are OFF.

IPDM E/R (INTELLIGENT POWER DISTRIBUTION MODULE ENGINE ROOM)

CONSULT-II Function (IPDM E/R)

EKS00FOU

CONSULT-II can display each diagnostic item using the diagnostic test modes shown following.

IPDM E/R diagnostic Mode	Description
SELF-DIAG RESULTS	Displays IPDM E/R self-diagnosis results.
DATA MONITOR	Displays IPDM E/R input/output data in real time.
CAN DIAG SUPPORT MNTR	The result of transmit/receive diagnosis of CAN communication can be read.
ACTIVE TEST	Operation of electrical loads can be checked by sending drive signal to them.

CONSULT-II START PROCEDURE

Refer to [GI-37, "CONSULT-II Start Procedure"](#).

SELF-DIAGNOSTIC RESULTS

Operation Procedure

1. Touch "SELF-DIAG RESULTS" on "SELECT DIAG MODE" screen.
2. Self-diagnosis results are displayed.

Display Item List

Display items	CONSULT-II display code	Malfunction detection	TIME		Possible causes
			CRNT	PAST	
NO DTC IS DETECTED. FURTHER TESTING MAY BE REQUIRED.	—	—	—	—	—
CAN COMM CIRC	U1000	<ul style="list-style-type: none"> ● If CAN communication reception/transmission data has a malfunction, or if any of the control units fail, data reception/transmission cannot be confirmed. ● When the data in CAN communication is not received before the specified time. 	X	X	Any of items listed below have errors: <ul style="list-style-type: none"> ● TRANSMIT DIAG ● ECM ● BCM/SEC

NOTE:

The details for display of the period are as follows:

- CRNT: Error currently detected with IPDM E/R.
- PAST: Error detected in the past and placed in IPDM E/R memory.

DATA MONITOR

Operation Procedure

1. Touch "DATA MONITOR" on "SELECT DIAG MODE" screen.
2. Touch "ALL SIGNALS", "MAIN SIGNALS" or "SELECTION FROM MENU" on the "DATA MONITOR" screen.

ALL SIGNALS	All signals will be monitored.
MAIN SIGNALS	Monitors the predetermined item(s).
SELECTION FROM MENU	Selects and monitors individual signal(s).

3. Touch "START".
4. When "SELECTION FROM MENU" is selected, touch items to be monitored. When "ALL SIGNALS" is selected, all the items will be monitored. When "MAIN SIGNALS" is selected, predetermined items are monitored.
5. Touch "RECORD" while monitoring to record the status of the item being monitored. To stop recording, touch "STOP".

IPDM E/R (INTELLIGENT POWER DISTRIBUTION MODULE ENGINE ROOM)

All Signals, Main Signals, Selection From Menu

Item name	CONSULT-II screen display	Display or unit	Monitor item selection			Description
			ALL SIGNALS	MAIN SIGNALS	SELECTION FROM MENU	
Motor fan request	MOTOR FAN REQ	1/2/3/4	X	X	X	Signal status input from ECM
Compressor request	AC COMP REQ	ON/OFF	X	X	X	Signal status input from ECM
Parking, license, and tail lamp request	TAIL & CLR REQ	ON/OFF	X	X	X	Signal status input from BCM
Headlamp low beam request	HL LO REQ	ON/OFF	X	X	X	Signal status input from BCM
Headlamp high beam request	HL HI REQ	ON/OFF	X	X	X	Signal status input from BCM
Front fog request	FR FOG REQ	ON/OFF	X	X	X	Signal status input from BCM
FR wiper request	FR WIP REQ	STOP/1LO/LO/HI	X	X	X	Signal status input from BCM
Wiper auto stop	WIP AUTO STOP	ACT P/STOP P	X	X	X	Output status of IPDM E/R
Wiper protection	WIP PROT	OFF/LS/HS/Block	X	X	X	Control status of IPDM E/R
Starter request	ST RLY REQ	ON/OFF	X		X	Status of input signal ^{NOTE}
Ignition relay status	IGN RLY	ON/OFF	X	X	X	Ignition relay status monitored with IPDM E/R
Rear defogger request	RR DEF REQ	ON/OFF	X	X	X	Signal status input from BCM
Oil pressure switch	OIL P SW	OPEN/CLOSE	X		X	Signal status input from IPDM E/R
Hood switch	HOOD SW (*1)	OFF	X		X	Signal status input from IPDM E/R
Theft warning horn request	THFT HRN REQ (*1)	ON/OFF	X		X	Signal status input from BCM
Horn chirp	HORN CHIRP	ON/OFF	X		X	Output status of IPDM E/R
Cornering lamp request	CRNRNG LMP REQ	OFF/LEFT/RIGHT	X		X	Signal status input from BCM

NOTE:

- Perform monitoring of IPDM E/R data with the ignition switch ON. When the ignition switch is in ACC position, display may not be correct.
- (*1) This item is displayed, but does not function.

CAN DIAG SUPPORT MNTR

Refer to [LAN-4, "SYSTEM DESCRIPTION"](#) .

ACTIVE TEST

Operation Procedure

1. Touch "ACTIVE TEST" on "SELECT DIAG-MODE" screen.
2. Touch item to be tested, and check operation.
3. Touch "START".
4. Touch "STOP" while testing to stop the operation.

Test name	CONSULT-II screen display	Description
Tail lamp output	TAIL LAMP	With a certain ON-OFF operation, the tail lamp relay can be operated.
Rear defogger output	REAR DEFOGGER	With a certain ON-OFF operation, the rear defogger relay can be operated.

IPDM E/R (INTELLIGENT POWER DISTRIBUTION MODULE ENGINE ROOM)

Test name	CONSULT-II screen display	Description
Front wiper (HI, LO) output	FRONT WIPER	With a certain operation (OFF, HI ON, LO ON), the front wiper relay (Lo, Hi) can be operated.
Cooling fan output	MOTOR FAN	With a certain operation (1, 2, 3, 4), the cooling fan can be operated.
Lamp (HI, LO, FOG) output	LAMPS	With a certain operation (OFF, HI ON, LO ON, FOG ON), the lamp relay (Lo, Hi, Fog) can be operated.
Cornering lamp output	CORNERING LAMP	—
Horn output	HORN	With a certain ON-OFF operation, the horn relay can be operated.

Auto Active Test DESCRIPTION

EKS00FOV

- In auto active test mode, operation inspection can be performed when IPDM E/R sends a drive signal to the following systems:
 - Rear window defogger
 - Front wipers
 - Tail, license and parking lamps
 - Cornering lamps
 - Front fog lamps
 - Headlamps (High, Low)
 - A/C compressor (magnet clutch)
 - Cooling fan

OPERATION PROCEDURE

1. Close hood and front door RH, and lift wiper arms away from windshield (to prevent glass damage by wiper operation).
NOTE:
When auto active test is performed with hood opened, sprinkle water on windshield beforehand.
2. Turn ignition switch OFF.
3. Turn ignition switch ON and, within 20 seconds, press front door switch LH 10 times. Then turn ignition switch OFF.
4. Turn ignition switch ON within 10 seconds after ignition switch OFF.
5. When auto active test mode is actuated, horn chirps once.
6. After a series of operations is repeated three times, auto active test is completed.

NOTE:

When auto active test mode has to be cancelled halfway, turn ignition switch OFF.

CAUTION:

Be sure to perform [BL-41, "Door Switch Check \(With Automatic Back Door System\)"](#) or [BL-39, "Door Switch Check \(Without Automatic Back Door System\)"](#) when the auto active test cannot be performed.

IPDM E/R (INTELLIGENT POWER DISTRIBUTION MODULE ENGINE ROOM)

INSPECTION IN AUTO ACTIVE TEST MODE

When auto active test mode is actuated, the following nine steps are repeated three times.

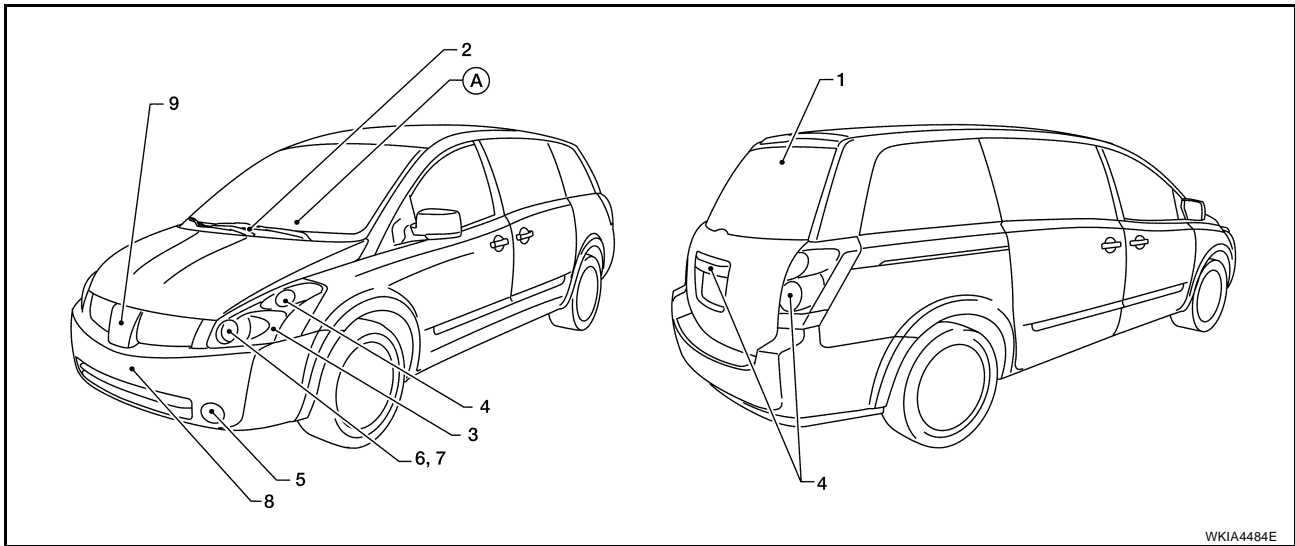

(A): Oil pressure warning lamp is blinking when the auto active test is operating.

Item Number	Test Item	Operation Time/Frequency
1	Rear window defogger	10 seconds
2	Front wipers	LOW 5 seconds then HIGH 5 seconds
3	Cornering lamps	10 seconds
4	Tail, license, and parking lamps	10 seconds
5	Front fog lamps	10 seconds
6	Headlamps (low)	10 seconds
7	Headlamps (high)	ON-OFF 5 times
8	A/C compressor (magnetic clutch)	ON-OFF 5 times
9	Cooling fan	LOW 2 seconds → MID 2 seconds → HIGH 2 seconds → MID 2 seconds → LOW 2 seconds

Concept of Auto Active Test

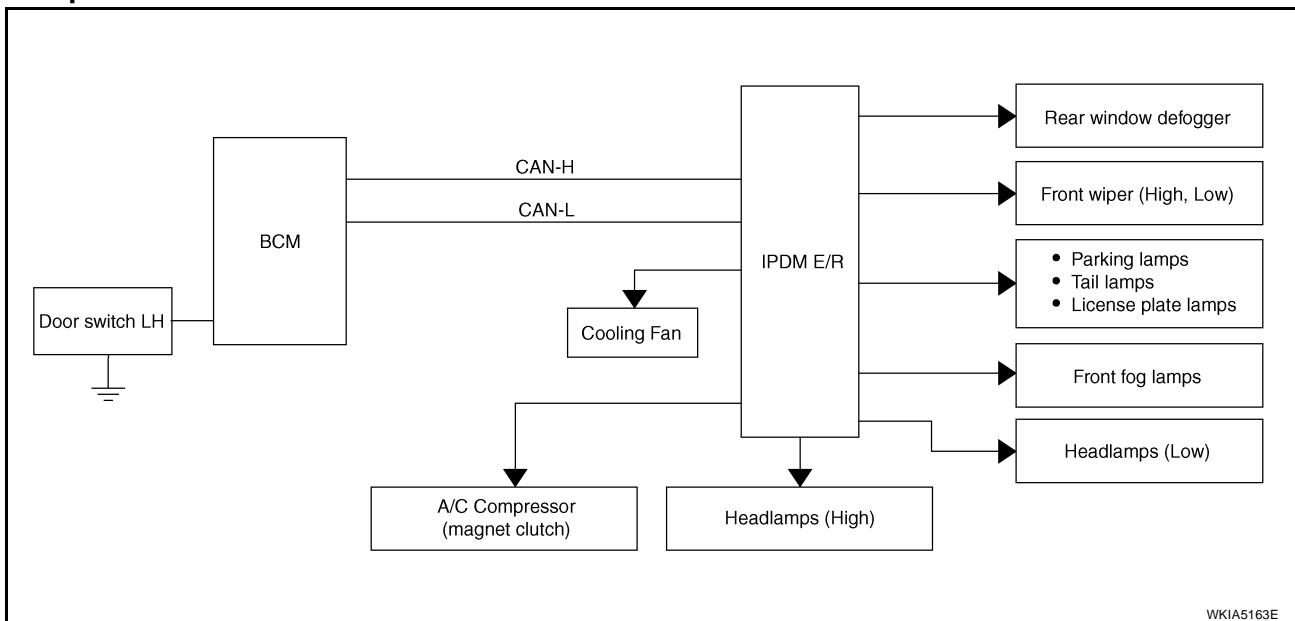

IPDM E/R (INTELLIGENT POWER DISTRIBUTION MODULE ENGINE ROOM)

- IPDM E/R actuates auto active test mode when it receives door switch signal from BCM via CAN communication line. Therefore, when auto active test mode is activated successfully, CAN communication between IPDM E/R and BCM is normal.
- If any of the systems controlled by IPDM E/R cannot be operated, possible cause can be easily diagnosed using auto active test.

Diagnosis chart in auto active test mode

Symptom	Inspection contents	Possible cause	
Rear window defogger does not operate.	Perform auto active test. Does rear window defogger operate?	YES	● BCM signal input circuit
		NO	<ul style="list-style-type: none"> ● Rear window defogger relay ● Open circuit of rear window defogger ● IPDM E/R malfunction ● Harness or connector malfunction between IPDM E/R and rear window defogger
Any of front wipers, tail and parking lamps, front fog lamps, cornering lamps, and headlamps (High, Low) do not operate.	Perform auto active test. Does system in question operate?	YES	● BCM signal input system
		NO	<ul style="list-style-type: none"> ● Lamp/wiper motor malfunction ● Lamp/wiper motor ground circuit malfunction ● Harness/connector malfunction between IPDM E/R and system in question ● IPDM E/R (integrated relay) malfunction
A/C compressor does not operate.	Perform auto active test. Does magnet clutch operate?	YES	<ul style="list-style-type: none"> ● BCM signal input circuit ● CAN communication signal between BCM and ECM. ● CAN communication signal between ECM and IPDM E/R
		NO	<ul style="list-style-type: none"> ● Magnet clutch malfunction ● Harness/connector malfunction between IPDM E/R and magnet clutch ● IPDM E/R (integrated relay) malfunction
Cooling fan does not operate.	Perform auto active test. Does cooling fan operate?	YES	<ul style="list-style-type: none"> ● ECM signal input circuit ● CAN communication signal between ECM and IPDM E/R
		NO	<ul style="list-style-type: none"> ● Cooling fan motor malfunction ● Harness/connector malfunction between IPDM E/R and cooling fan motor ● IPDM E/R (integrated relay) malfunction
Oil pressure warning lamp does not operate.	Perform auto active test. Does oil pressure warning lamp blink?	YES	<ul style="list-style-type: none"> ● Harness/connector malfunction between IPDM E/R and oil pressure switch ● Oil pressure switch malfunction ● IPDM E/R
		NO	<ul style="list-style-type: none"> ● CAN communication signal between BCM and Combination Meter ● Combination meter

A
B
C
D
E
F
G
H
I
J
PG
L
M

IPDM E/R Terminal Arrangement

EKS00FOX

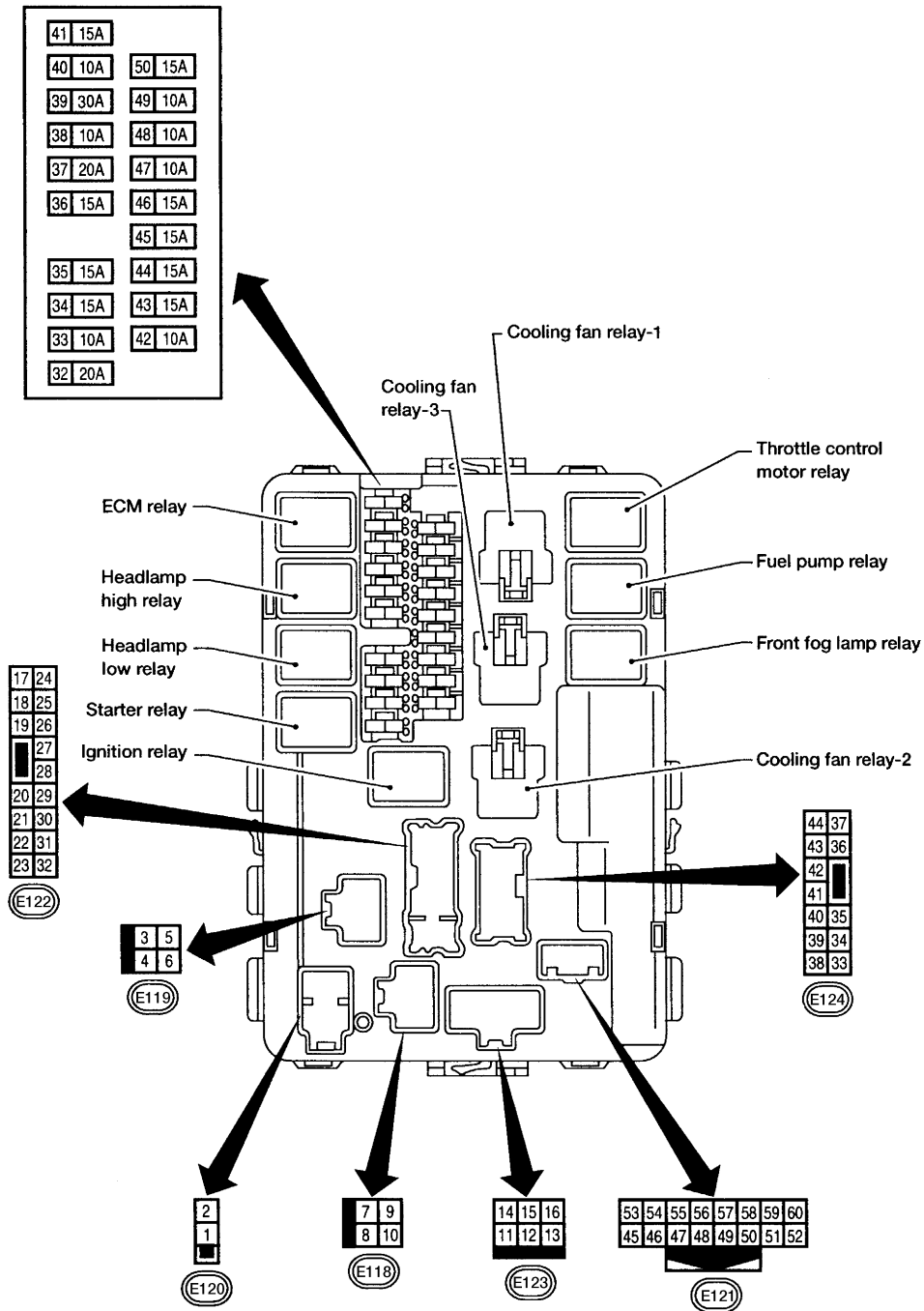

WKIA1203E

IPDM E/R (INTELLIGENT POWER DISTRIBUTION MODULE ENGINE ROOM)

Terminals and Reference Values for IPDM E/R

EKS00HS7

Terminal	Wire color	Signal name	Signal input/output	Measuring condition		Reference value (Approx.)
				Ignition switch	Operation or condition	
1	R	Battery power supply	Input	OFF	—	Battery voltage
2	B/Y	Battery power supply	Input	OFF	—	Battery voltage
3	B/W	Starter motor	Output	START	—	Battery voltage
4	B/R	Ignition switch	Input	—	OFF or ACC or ON	0V
					START	Battery voltage
5	W	Rear window defogger	Output	—	—	Battery voltage
6	L	Battery power supply (Rear window defogger)	Output	—	—	Battery voltage
7	B/W	Ignition switch supplied power	Input	—	OFF or ACC	0V
					ON or START	Battery voltage
8	L	Cooling fan motor low 1	Input	—	Ignition switch ON or START, with engine coolant temperature above 100 °C (212 °F) or with air conditioner switch : ON	0V
					Ignition switch OFF or ACC, with engine coolant temperature below 100 °C (212 °F) or with air conditioner switch : OFF	Battery voltage
10	L/B	Cooling fan motor high 2	Output	—	Ignition switch ON or START, with engine coolant temperature 105 °C (221 °F) or higher with air conditioner switch : ON	Battery voltage
					Ignition switch ON or START, with engine coolant temperature between 95 °C (203 °F) and 99 °C (210 °F) or with air conditioner switch : OFF	Less than battery voltage
11	R	Cooling fan motor high 1	Input	—	Ignition switch ON or START, with engine coolant temperature 105 °C (221 °F) or higher with air conditioner switch : ON	0V
					Ignition switch OFF or ACC, with engine coolant temperature 94 °C (201 °F) or less or with air conditioner switch : OFF	Battery voltage
					Ignition switch ON or START, with engine coolant temperature between 95 °C (203 °F) and 99 °C (210 °F) or with air conditioner switch : OFF	Less than battery voltage

A
B
C
D
E
F
G
H
I
J
PG
L
M

IPDM E/R (INTELLIGENT POWER DISTRIBUTION MODULE ENGINE ROOM)

Terminal	Wire color	Signal name	Signal input/output	Measuring condition		Reference value (Approx.)	
				Ignition switch	Operation or condition		
12	R	Cooling fan motor ground 2	Input	—	Ignition switch ON or START, with engine coolant temperature between 95 °C (203 °F) and 99 °C (210 °F) or with air conditioner switch : OFF	Less than battery voltage	
					Ignition switch OFF or ACC, or with engine coolant temperature below 95 °C (203 °F) or with engine coolant temperature above 99 °C (210 °F) but below 105 °C (221 °F) or with air conditioner switch : OFF	Battery voltage	
					Ignition switch ON or START, with engine coolant temperature 105 °C (221 °F) or higher with air conditioner switch : ON	0V	
13	R/Y	Cooling fan motor low 2	Output	—	Ignition switch ON or START, with engine coolant temperature above 100 °C (212 °F) or with air conditioner switch : ON	Battery voltage	
					Ignition switch OFF or ACC, with engine coolant temperature below 100 °C (212 °F) or with air conditioner switch : OFF	0V	
14	L/B	Cooling fan motor ground	Output	—	Ignition switch ON or START, with engine coolant temperature between 95 °C (203 °F) and 99 °C (210 °F) or with air conditioner switch : OFF	Less than battery voltage	
					Ignition switch ON or START, with engine coolant temperature 105 °C (221 °F) or higher with air conditioner switch : ON	0V	
15	G	Battery power supply	Input	—	—	Battery voltage	
16	B	Ground	Input	—	—	0V	
17	R	ECM Relay	Output	—	Ignition switch ON or START	Battery voltage	
18	R/G	ECM relay	Output	—	Ignition switch ON or START	Battery voltage	
					Ignition switch OFF or ACC	0V	
20	R/Y	RH Low beam head-lamp	Output	—	Lighting switch in 2nd position	Battery voltage	
21	L	Wiper low speed signal	Output	ON or START	Wiper switch	OFF	0V
						LO	Battery voltage
22	R/L	Rear parking, license plate, and tail lamp	Output	—	Lighting switch 1ST position	OFF	0V
						ON	Battery voltage
23	W/L	RH Cornering lamp	Output	—	Lighting switch ON or AUTO and turn signal switch in the RIGHT position	Battery voltage	

IPDM E/R (INTELLIGENT POWER DISTRIBUTION MODULE ENGINE ROOM)

Terminal	Wire color	Signal name	Signal input/output	Measuring condition		Reference value (Approx.)	
				Ignition switch	Operation or condition		
24	G	Ignition 1	Output	—	Ignition switch ON or START	Battery voltage	
					Ignition switch OFF or ACC	0V	
25	P	Ignition 1	Output	—	Ignition switch ON or START	Battery voltage	
					Ignition switch OFF or ACC	0V	
26	P	Ignition 1	Output	—	Ignition switch ON or START	Battery voltage	
					Ignition switch OFF or ACC	0V	
27	L/W	RH High beam head-lamp	Output	—	Lighting switch in 2nd position and placed in HIGH or PASS position	Battery voltage	
28	G	LH High beam head-lamp	Output	—	Lighting switch in 2nd position and placed in HIGH or PASS position	Battery voltage	
30	L	LH Low beam head-lamp	Output	—	Lighting switch in 2nd position	Battery voltage	
31	L/B	Wiper high speed signal	Output	ON or START	Wiper switch	OFF	0V
						HI	Battery voltage
32	L/Y	Wiper auto stop signal	Input	ON or START	Wipers not in park position		Battery voltage
					Wipers in park position		0V
33	Y/B	A/C compressor	Output	ON or START	A/C switch or auto A/C request ON		Battery voltage
					A/C switch or auto A/C request OFF		0V
34	WG	LH Cornering lamp	Output	—	Lighting switch ON or AUTO and turn signal switch in the LEFT position	Battery voltage	
36	W/G	Front fog lamp (RH)	Output	ON or START	Lighting switch must be in the 2ND position or AUTO position (LOW beam is ON) and the front fog lamp switch	OFF	0V
						ON	Battery voltage
37	W/R	Front fog lamp (LH)	Output	ON or START	Lighting switch must be in the 2ND position or AUTO position (LOW beam is ON) and the front fog lamp switch	OFF	0V
						ON	Battery voltage
38	B	Ground	Input	—	—	0V	
39	B/Y	Fuel pump	Output	—	Ignition switch ON or START	Battery voltage	
					Ignition switch OFF or ACC	0V	
40	B/O	Fuel pump relay control	Input	—	Ignition switch ON or START	0V	
					Ignition switch OFF or ACC	Battery voltage	
41	G	Battery power supply	Output	—	—	Battery voltage	

A
B
C
D
E
F
G
H
I
J
PG
L
M

IPDM E/R (INTELLIGENT POWER DISTRIBUTION MODULE ENGINE ROOM)

Terminal	Wire color	Signal name	Signal input/output	Measuring condition		Reference value (Approx.)
				Ignition switch	Operation or condition	
42	R	Throttle control motor relay	Output	—	Ignition switch ON or START	Battery voltage
					Ignition switch OFF or ACC	0V
43	GR	Ignition 1	Output	—	Ignition switch ON or START	Battery voltage
					Ignition switch OFF or ACC	0V
44	Y/R	Ignition 1	Output	—	Ignition switch ON or START	Battery voltage
					Ignition switch OFF or ACC	0V
46	W/B	ECM relay control	Input	—	Ignition switch ON or START	0V
					Ignition switch OFF or ACC	Battery voltage
47	O	Throttle control motor relay control	Input	—	Ignition switch ON or START	0V
					Ignition switch OFF or ACC	Battery voltage
48	L	CAN-H	—	ON	—	—
49	P	CAN-L	—	ON	—	—
50	B	Ground	Input	—	—	0V
51	G/W	Horn relay control	Input	—	Horn switch : PUSHED or when a door is locked or unlocked via the keyfob	0V
					Horn switch: RELEASED or with no door lock feature activated via the keyfob	Battery voltage
52	G/R	Rear window defogger relay control	Input	ON or START	Defogger Switch: ON	0V
					Defogger Switch: OFF	Battery voltage
53	G/R	Starter relay (inhibit switch)	Input	ON or START	Selector lever in "P" or "N"	Battery voltage
					Selector lever any other position	0V
57	P/L	Oil pressure switch	Input	ON or START	—	Battery voltage
60	B	Ground	Input	—	—	0V

IPDM E/R (INTELLIGENT POWER DISTRIBUTION MODULE ENGINE ROOM)

IPDM E/R Power/Ground Circuit Inspection

EKS00FOY

1. FUSE AND FUSIBLE LINK INSPECTION

Check that the following fusible links or IPDM E/R fuses are not blown.

Terminal No.	Signal name	Fuse, fusible link No.
1, 2	Battery power	c, d

OK or NG

- OK >> GO TO 2.
- NG >> Replace fuse or fusible link.

2. POWER CIRCUIT INSPECTION

1. Turn ignition switch OFF.
2. Disconnect IPDM E/R harness connector E120.
3. Check voltage between IPDM E/R harness connector E120 terminals 1, 2 and ground.

Battery voltage should exist.

OK or NG

- OK >> GO TO 3.
- NG >> Repair or replace IPDM E/R power circuit harness.

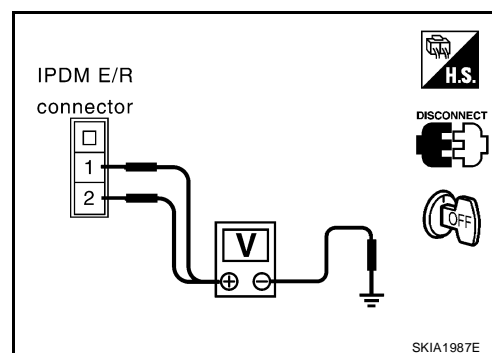

3. GROUND CIRCUIT INSPECTION

1. Disconnect IPDM E/R harness connectors E121 and E124.
2. Check continuity between IPDM E/R harness connector E121(A) terminal 60, E124(B) terminal 38 and ground.

Continuity should exist.

OK or NG

- OK >> Inspection End.
- NG >> Repair or replace IPDM E/R ground circuit harness.

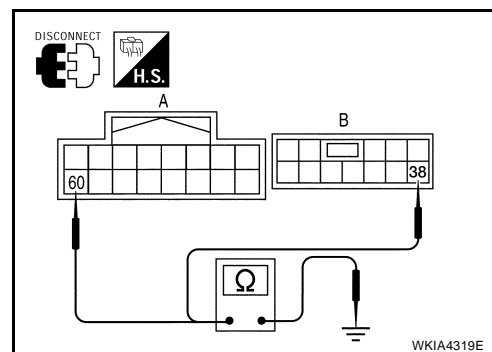

IPDM E/R (INTELLIGENT POWER DISTRIBUTION MODULE ENGINE ROOM)

Inspection with CONSULT-II (Self-Diagnosis)

EKS00FOZ

CAUTION:

If a CONSULT-II is used with no connection of CONSULT-II CONVERTER, malfunctions might be detected in self-diagnosis depending on which control unit(s) carry out CAN communication.

1. SELF-DIAGNOSIS RESULT CHECK

1. Connect CONSULT-II and select "IPDM E/R" on the "SELECT SYSTEM" screen.
2. Select "SELF-DIAG RESULTS" on the "SELECT DIAG MODE" screen.
3. Check display content in self-diagnosis results.

CONSULT-II Display	CONSULT-II display code	TIME		Details of diagnosis result
		CRNT	PAST	
NO DTC IS DETECTED. FURTHER TESTING MAY BE REQUIRED.	—	—	—	No malfunction
CAN COMM CIRC	U1000	X	X	Any of items listed below have errors: <ul style="list-style-type: none">● TRANSMIT DIAG● ECM● BCM/SEC

NOTE:

The Details for Display for the Period are as follows:

- CRNT: Error currently detected by IPDM E/R.
- PAST: Error detected in the past and stored in IPDM E/R memory.

Contents displayed

NO DTC DETECTED. FURTHER TESTING MAY BE REQUIRED.>>INSPECTION END.

CAN COMM CIRC>>Print out the self-diagnosis result and refer to [LAN-4, "SYSTEM DESCRIPTION"](#) .

IPDM E/R (INTELLIGENT POWER DISTRIBUTION MODULE ENGINE ROOM)

EKS00FP0

Removal and Installation of IPDM E/R

REMOVAL

1. Disconnect negative battery cable.
2. Remove coolant reservoir fasteners.
3. Move coolant reservoir aside.
4. Remove IPDM E/R upper cover.

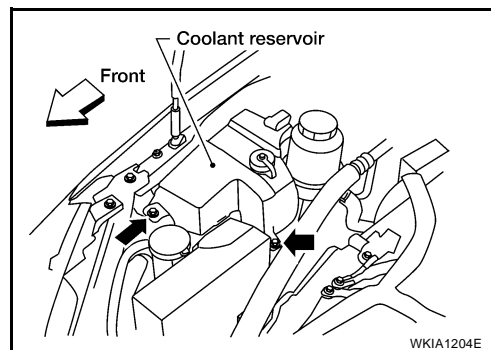

5. Remove IPDM E/R harness cover.

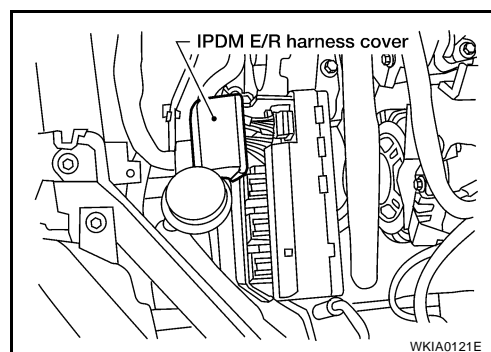

6. Release 2 clips and pull IPDM E/R up from case.
7. Disconnect IPDM E/R connectors and remove the IPDM E/R.

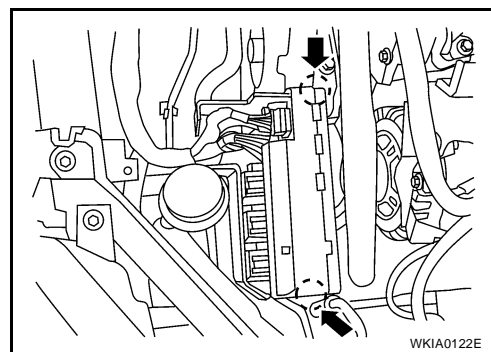

INSTALLATION

Installation is in the reverse order of removal.

A
B
C
D
E
F
G
H
I
J
PG
L
M

GROUND CIRCUIT

PFP:24080

EKS00FP1

GROUND CIRCUIT

Ground Distribution MAIN HARNESS

View with instrument lower panel LH removed

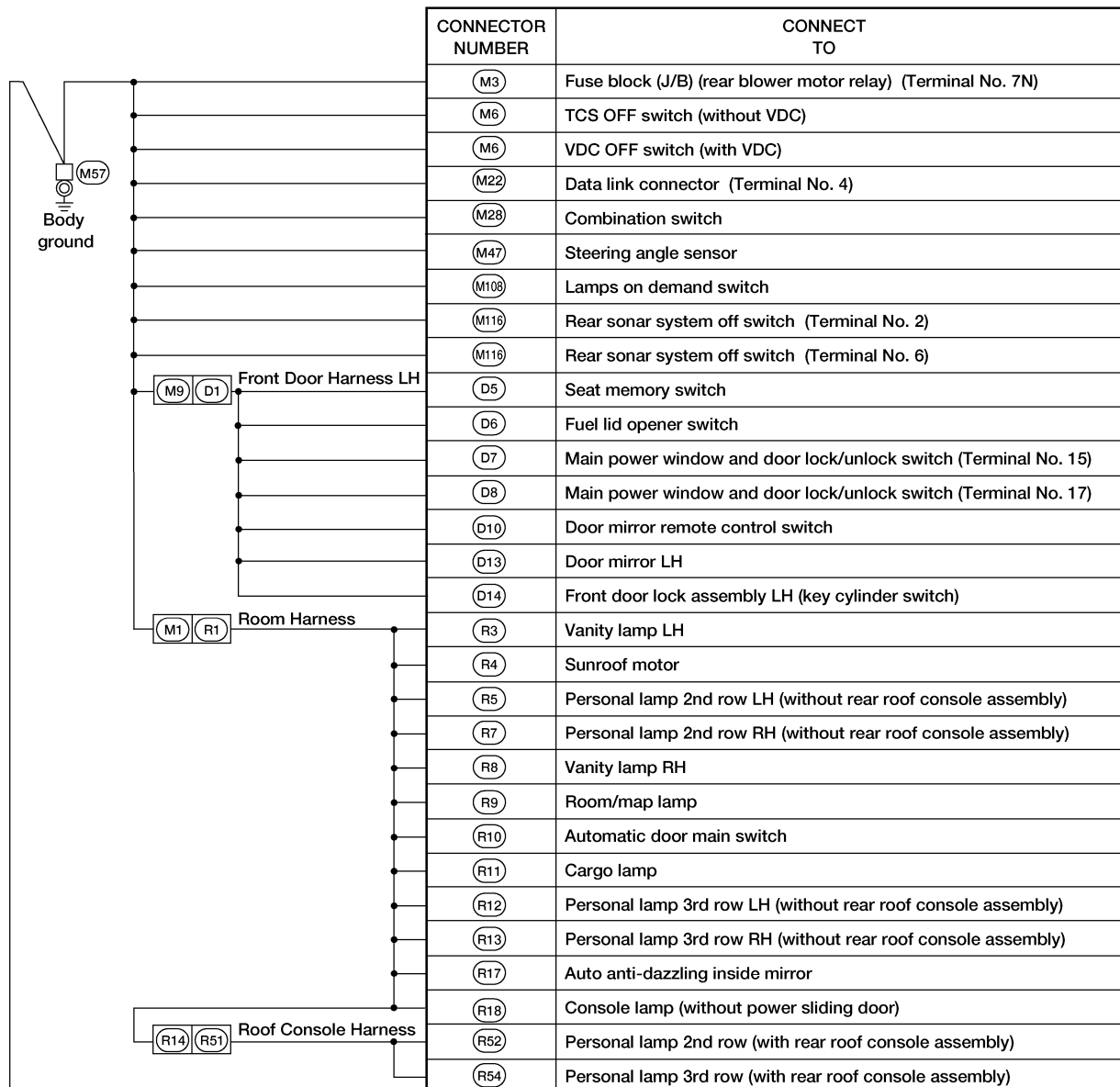
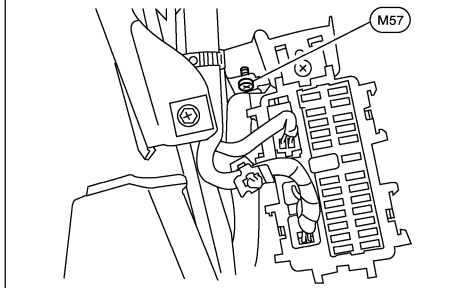

Next page

WKIA5413E

GROUND CIRCUIT

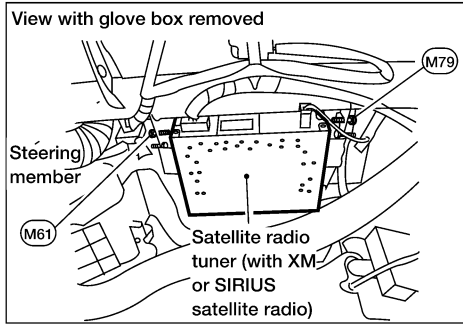

Preceding page

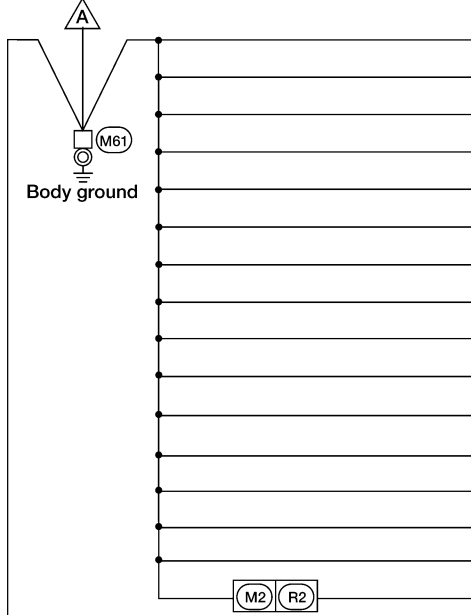

CONNECTOR NUMBER	CONNECT TO
M14	Pedal adjusting control unit (Terminal No. 1)
M20	BCM (body control module) (Terminal No. 67)
M21	NATS antenna amplifier
M22	Data link connector (Terminal No. 5)
M31	Passenger air bag off indicator
M32	In-vehicle sensor
M34	A/T device (Terminal No. 6)
M35	Air bag diagnosis sensor unit (Terminal No. 2)
M42	Automatic drive positioner control unit (Terminal No. 48)
M49	Front air control (Terminal No. 36)
M55	Hazard switch
M56	Front power socket LH
M59	Glove box lamp
M122	Variable blower control (Terminal No. 4)
M154	DVD player
R19	Rear air control (front)

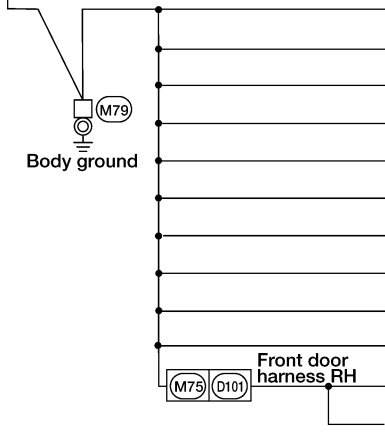

CONNECTOR NUMBER	CONNECT TO
M7	Door mirror remote control switch (with automatic drive positioner)
M24	Combination meter (Terminal No. 20)
M24	Combination meter (Terminal No. 21)
M33	Front power socket RH
M42	Automatic drive positioner control unit (Terminal No. 40)
M93	Display unit (Terminal No. 6) (with monochrome display)
M93	Display unit (Terminal No. 1) (with color display)
M94	Display control unit (Terminal No. 3) (with color display)
M98	AV switch
M113	BOSE [®] speaker amp.
D105	Power window and door lock/unlock switch RH
D113	Door mirror RH

A
B
C
D
E
F
G
H
I
J
L
M

PG

WKIA6234E

GROUND CIRCUIT

ENGINE ROOM HARNESS

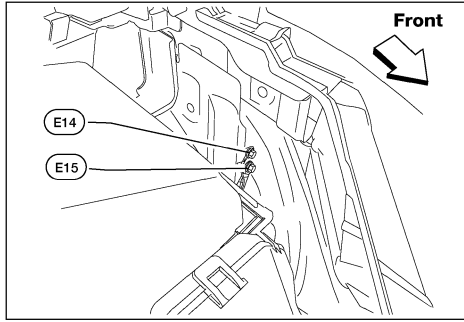

CONNECTOR NUMBER	CONNECT TO
(E4)	Crash zone sensor (shield wire)

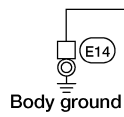

CONNECTOR NUMBER	CONNECT TO
(E11)	Front combination lamp LH
(E12)	Front combination lamp RH (headlamp low)
(E13)	Front combination lamp RH (headlamp high)
(E21)	Brake fluid level switch
(E23)	Front wiper motor
(E43)	Cornering lamp LH
(E44)	Front combination lamp LH (headlamp low)
(E45)	Front combination lamp LH (headlamp high) (without DTRL)
(E101)	Front fog lamp RH
(E102)	Front fog lamp LH
(E103)	Daytime light control unit (Terminal No. 9)
(E127)	Heater pump
(E148)	Daytime light relay
(H-2)	Front blower motor relay

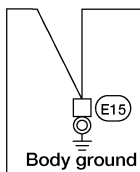

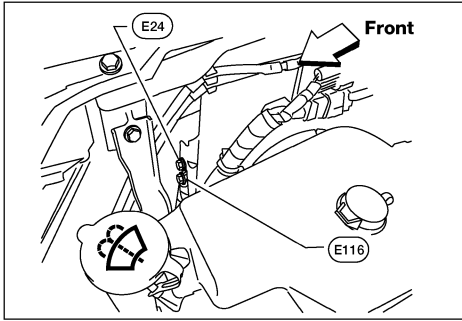

 Next page

GROUND CIRCUIT

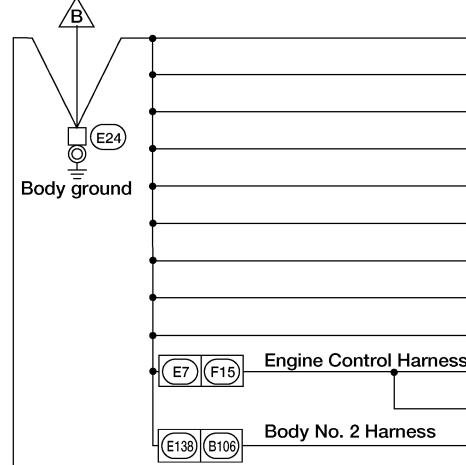

Preceding page



CONNECTOR NUMBER	CONNECT TO
E106	Washer fluid level switch
E107	Front combination lamp RH
E113	Cooling fan motor-1 (Terminal No. 3)
E113	Cooling fan motor-1 (Terminal No. 4)
E121	IPDM E/R (intelligent power dist module eng room) (Terminal No. 60)
E123	IPDM E/R (intelligent power dist module eng room) (Terminal No. 16)
E124	IPDM E/R (intelligent power dist module eng room) (Terminal No. 38)
E137	Cornering lamp RH
E142	TCM (Terminal No. 48)
F37	Turbine revolution sensor (shield wire)
F38	Revolution sensor (shield wire)
B125	Yaw rate/side/decel G-sensor (shield wire)

Next page

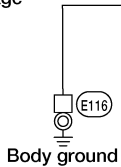

CONNECTOR NUMBER	CONNECT TO
E112	Generator

A
B
C
D
E
F
G
H
I
J
L
M

PG

WKIA5236E

GROUND CIRCUIT

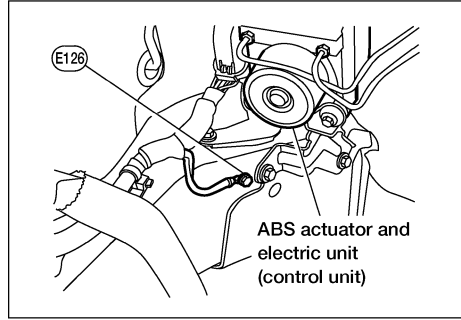
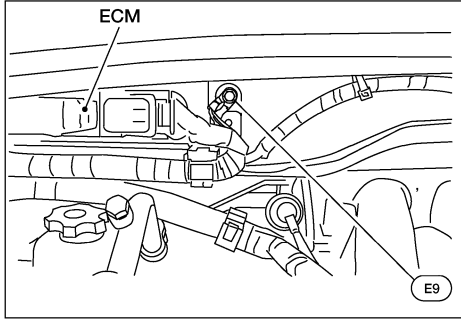

Preceding page

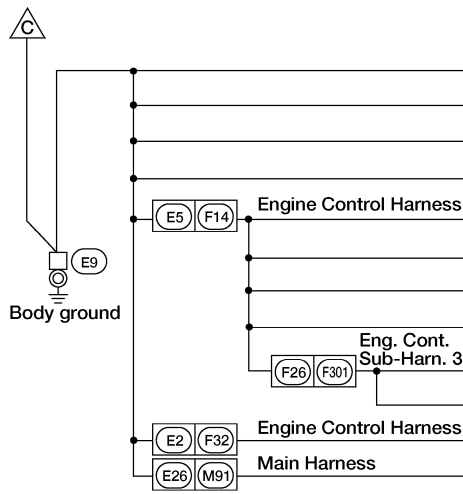

CONNECTOR NUMBER	CONNECT TO
E16	ECM (Terminal 115)
E16	ECM (Terminal 116)
E121	IPDM E/R (Intelligent power distribution engine room) (Terminal 50)
E143	TCM (Terminal 14)
F11	Crankshaft position sensor
F23	Camshaft position sensor (Phase) (Bank 2)
F50	Electronic throttle control actuator (Throttle position sensor) (shield wire)
F54	ECM (Terminal 1)
F302	Knock sensor
F303	Camshaft position sensor (Phase) (Bank 1)
F29	Park/neutral position (PNP) switch
M34	A/T device (Terminal 2)

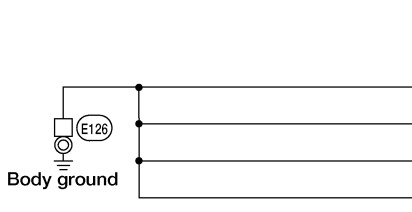

CONNECTOR NUMBER	CONNECT TO
E125	ABS actuator and electric unit (control unit) (without VDC) (Terminal No. 3)
E125	ABS actuator and electric unit (control unit) (without VDC) (Terminal No. 4)
E125	ABS actuator and electric unit (control unit) (with VDC) (Terminal No. 31)
E125	ABS actuator and electric unit (control unit) (with VDC) (Terminal No. 46)

WKIA5237E

GROUND CIRCUIT

ENGINE CONTROL HARNESS

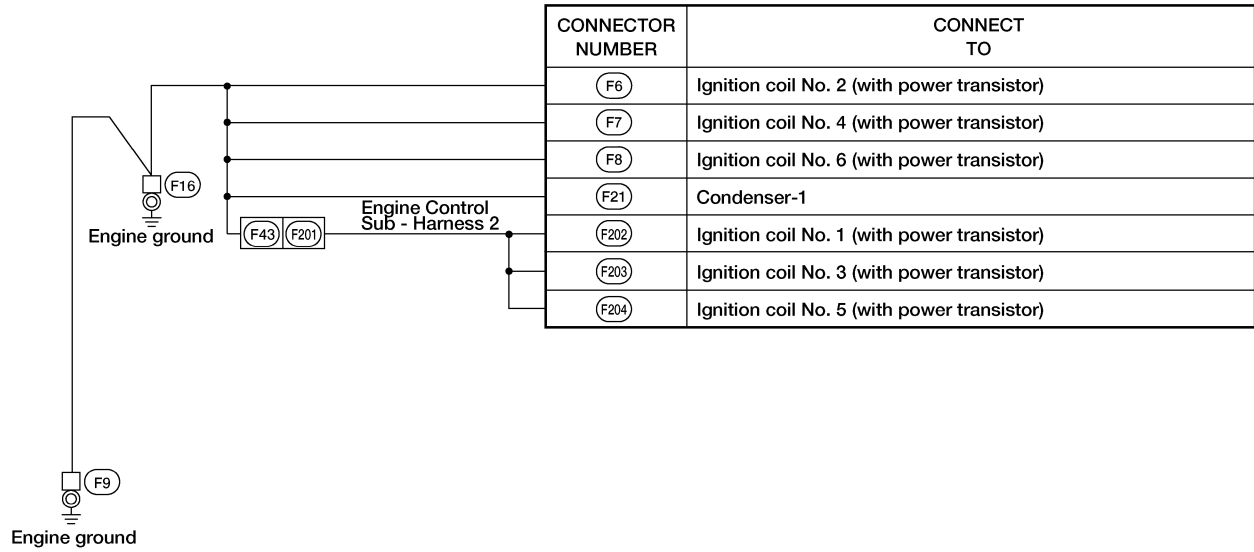
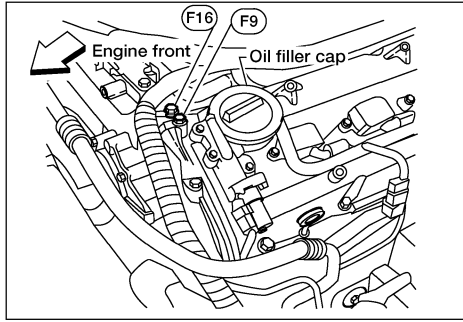

A
B
C
D
E
F
G
H
I
J
PG
L
M

GROUND CIRCUIT

BODY HARNESS

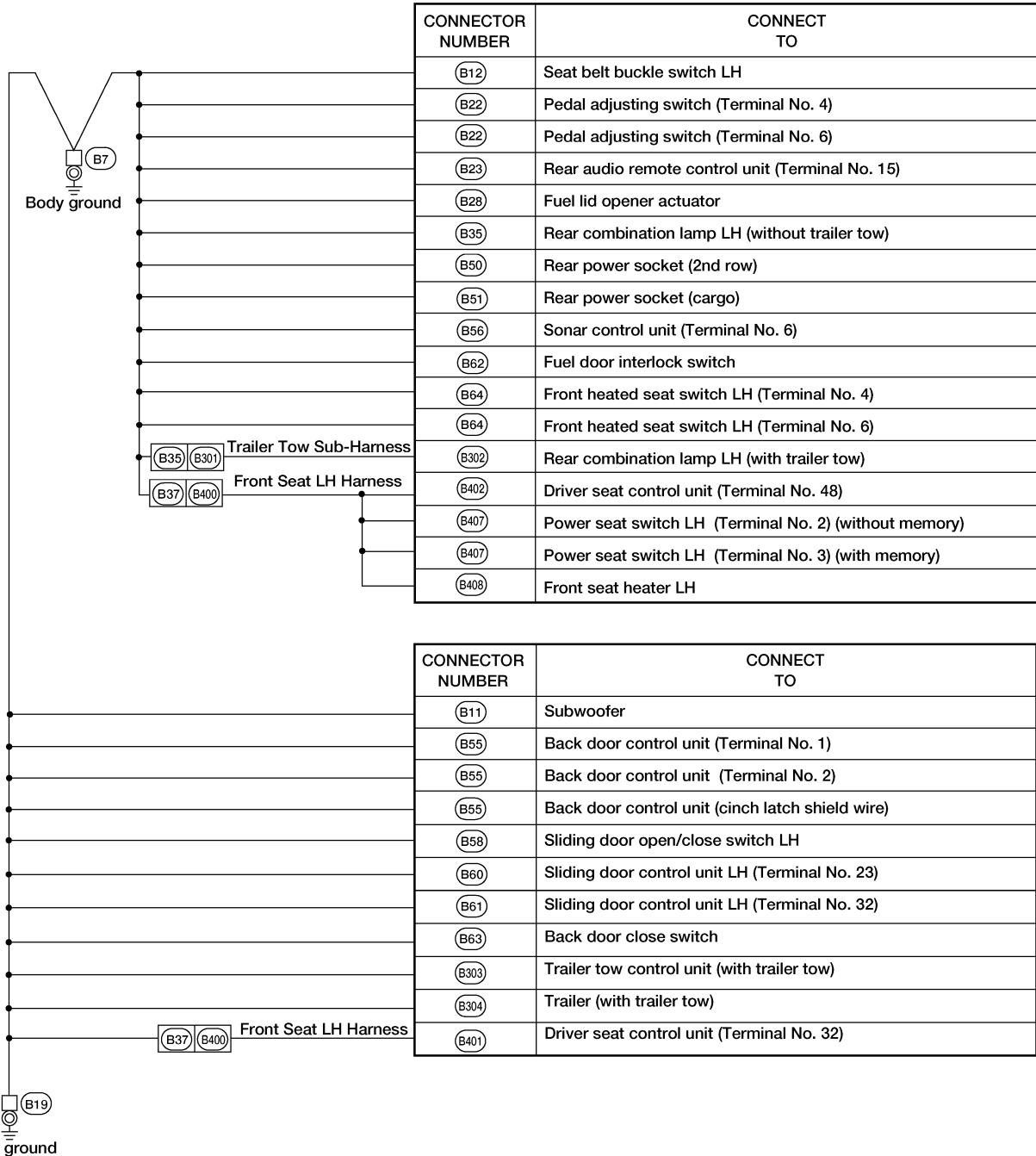
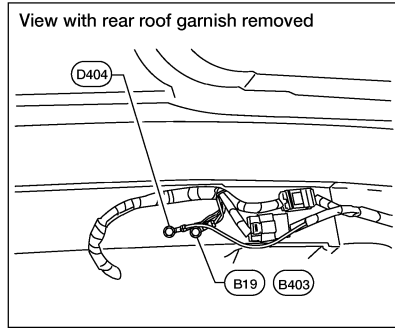
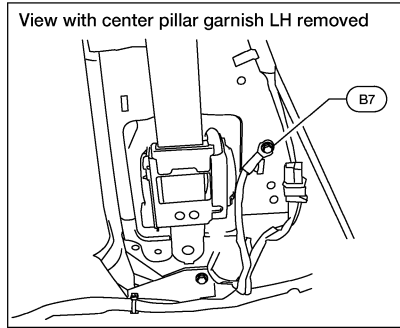

WKIA5239E

GROUND CIRCUIT

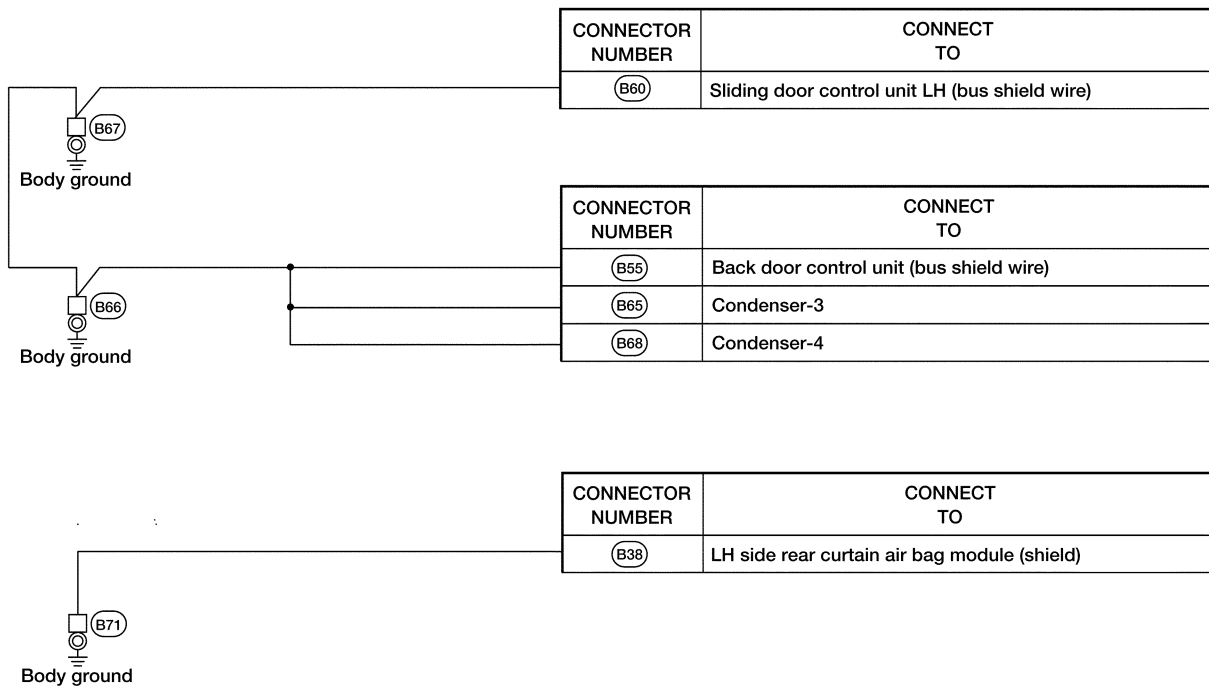
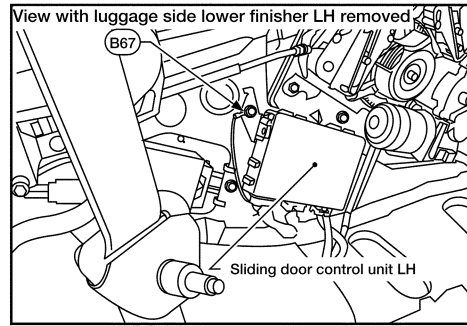
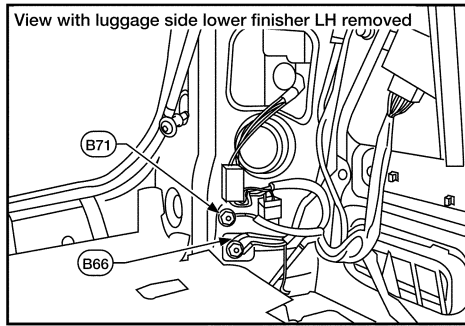

A
B
C
D
E
F
G
H
I
J
L
M

PG

WKIA4491E

GROUND CIRCUIT

BODY NO. 2 HARNESS

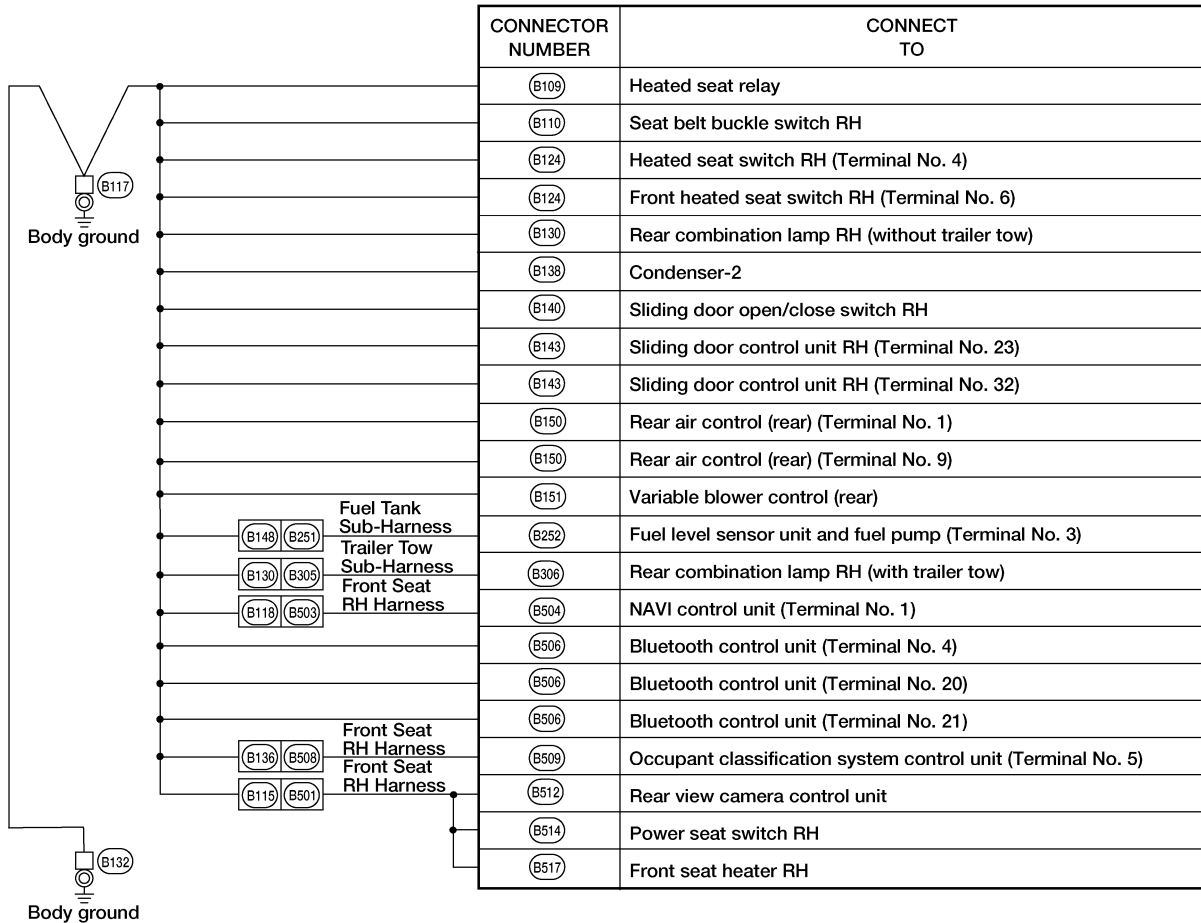
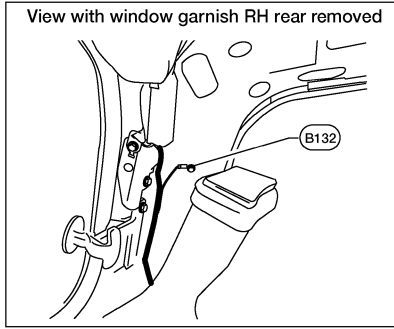
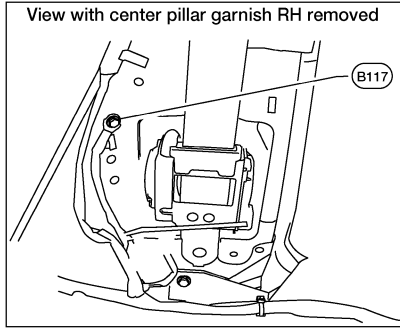

WKIA5240E

GROUND CIRCUIT

BACK DOOR NO. 2 HARNESS

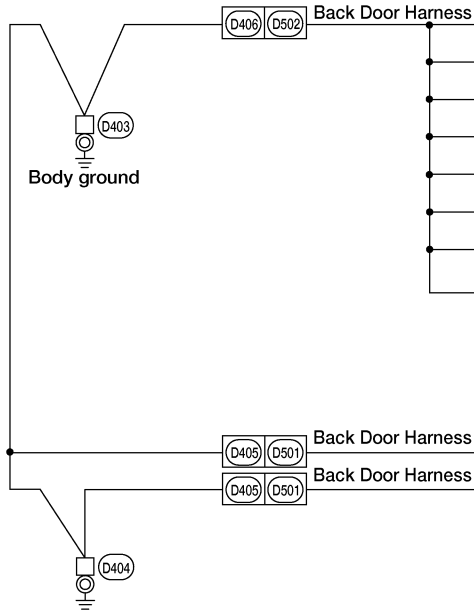
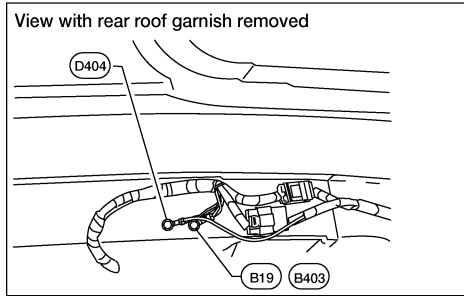

CONNECTOR NUMBER	CONNECT TO
D503	High mounted stop lamp
D507	Rear wiper motor (Terminal No. E)
D507	Rear wiper motor (Terminal No. G)
D508	License plate lamp RH
D509	License plate lamp LH
D510	Back door handle switch
D511	Back door latch
D512	Back door switch
D518	Rear view camera

CONNECTOR NUMBER	CONNECT TO
D511	Back door latch (cinch latch motor shield)
D515	Rear window defogger

WKIA5241E

A
B
C
D
E
F
G
H
I
J
L
M

PG

HARNESS

PF2:24010

EKS0018L

HARNESS

Harness Layout

HOW TO READ HARNESS LAYOUT

The following Harness Layouts use a map style grid to help locate connectors on the drawings:

- Main Harness and Air Conditioner Control Sub-harness
- Engine Room Harness (RH View) Engine Compartment
- Engine Room Harness (Passenger Compartment)
- Engine Room Harness (LH View) Engine Compartment
- Engine Control Harness, Engine Control Sub-harness-1, Engine Control Sub-harness-2 and Engine Control Sub-harness-3
- Body Harness, Rear Sonar Sensor Sub-harness and Trailer Tow Sub-harness
- Body No. 2 Harness and Fuel Tank Sub-harness
- Room Lamp Harness and Overhead Console harness
- Back Door Harness and Back Door No. 2 Harness

To use the grid reference

1. Find the desired connector number on the connector list.
2. Find the grid reference.
3. On the drawing, find the crossing of the grid reference letter column and number row.
4. Find the connector number in the crossing zone.
5. Follow the line (if used) to the connector.

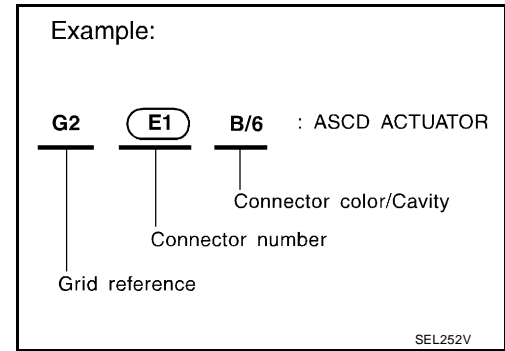

CONNECTOR SYMBOL

Main symbols of connector (in Harness Layout) are indicated below.

Connector type	Water proof type		Standard type	
	Male	Female	Male	Female
<ul style="list-style-type: none"> ● Cavity: 4 or Less ● Relay connector 				
<ul style="list-style-type: none"> ● Cavity: From 5 to 8 				
<ul style="list-style-type: none"> ● Cavity: 9 or More 				
<ul style="list-style-type: none"> ● Ground terminal etc. 	—			

HARNESSES

OUTLINE

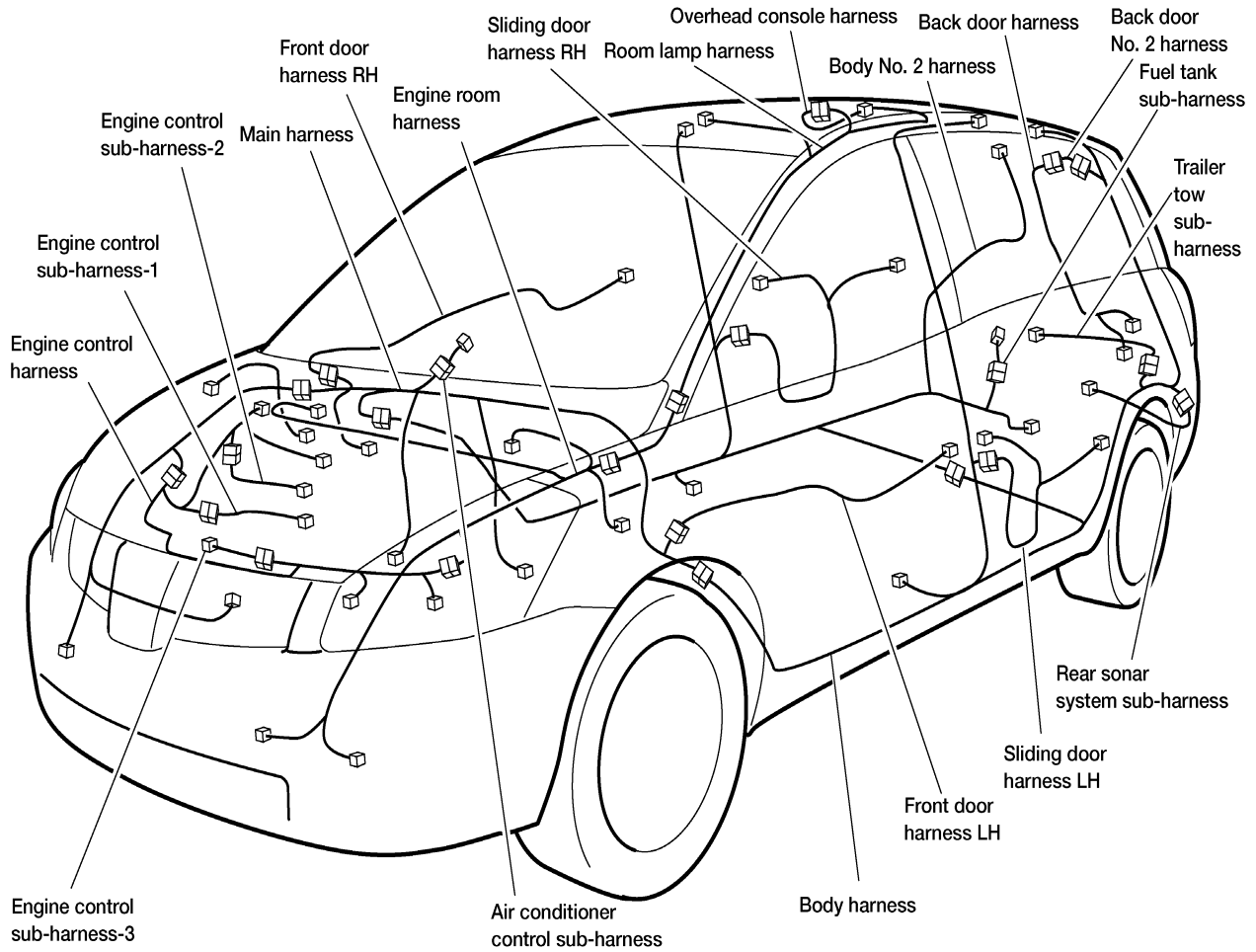

A

B

C

D

E

F

G

H

I

J

PG

L

M

WKIA5381E

HARNESS

MAIN HARNESS

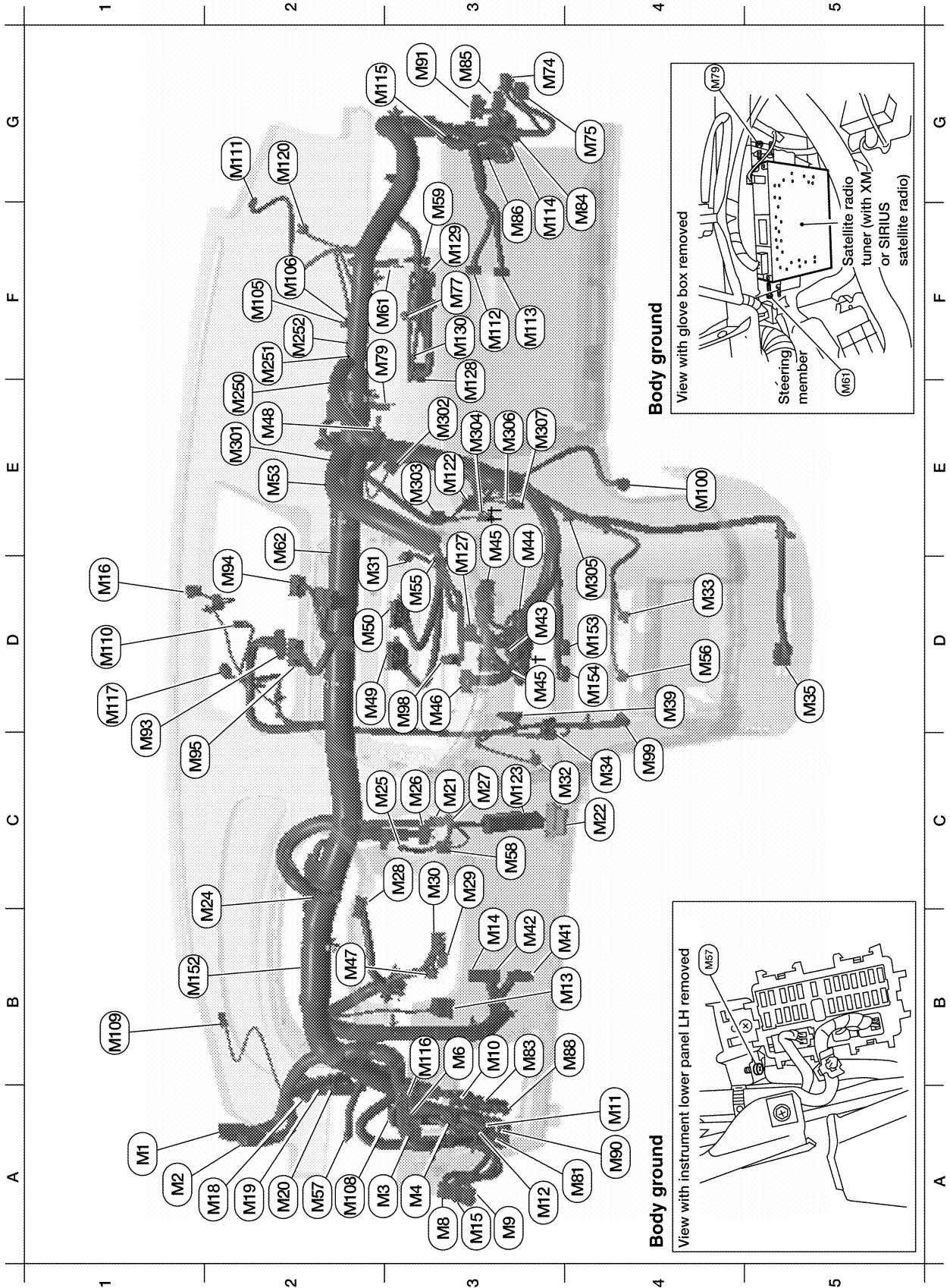

WKIA5382E

HARNESSES

A1	M1	W/16	: To R1	E2	M53	W/16	: To M301	A
A1	M2	W/32	: To R2	D3	M55	W/4	: Hazard switch	
A2	M3	W/8	: Fuse block (J/B)	D4	M56	B/3	: Front power socket LH	B
A3	M4	W/16	: Fuse block (J/B)	A2	M57	—	: Body ground	
B3	M6	GR/6	: TCS OFF switch (without VDC)	C3	M58	B/6	: Intake door motor driver	C
B3	M6	GR/6	: VDC OFF switch (with VDC)	G3	M59	BR/2	: Glove box lamp	
A3	M8	W/12	: To D2	F2	M61	—	: Body ground	D
A3	M9	GR/12	: To D1	E2	M62	W/2	: Front blower motor	
B3	M10	W/4	: To E29	G3	M74	W/16	: To D102	E
A4	M11	W/16	: To B1	G4	M75	W/8	: To D101	
A3	M12	GR/24	: To B2	F3	M77	Y/4	: Front passenger air bag module (service replacement)	F
B4	M13	L/4	: Fuel lid opener relay	F2	M79	—	: Body ground	
B3	M14	W/16	: Pedal adjusting control unit	A4	M81	W/16	: To B20	G
A3	M15	W/20	: To D15	B3	M83	W/12	: To E134	
D1	M16	B/4	: Optical sensor	F4	M84	W/16	: To B101	H
A2	M18	W/40	: BCM (body control module)	G3	M85	BR/24	: To B102	
A2	M19	W/15	: BCM (body control module)	F3	M86	BR/20	: To B103	I
A2	M20	B/15	: BCM (body control module)	B4	M88	Y/4	: To E42	
C3	M21	W/4	: NATS antenna amp.	A4	M90	W/24	: To E25	J
C4	M22	W/16	: Data link connector	G3	M91	BR/16	: To E26	
C2	M24	W/40	: Combination meter	C1	M93	W/24	: Display unit	PG
C3	M25	W/2	: Ignition keyhole illumination	D2	M94	W/24	: Display control unit (with color display)	
C3	M26	W/6	: Ignition switch	C1	M95	W/32	: Display control unit (with color display)	L
C3	M27	W/2	: Key switch	D2	M98	W/16	: AV switch	
C3	M28	W/16	: Combination switch	C4	M99	BR/2	: Foot lamp LH	M
C4	M29	Y/6	: Combination switch (spiral cable)	E4	M100	BR/2	: Foot lamp RH	
C3	M30	GR/8	: Combination switch (spiral cable)	F2	M105	Y/2	: Front passenger air bag module	
D2	M31	W/3	: Passenger air bag OFF indicator	F2	M106	O/2	: Front passenger air bag module	
C3	M32	W/4	: In-vehicle sensor	A2	M108	BR/6	: Lamps on demand switch	
D4	M33	B/3	: Front power socket RH	B1	M109	BR/2	: Front tweeter LH	
C4	M34	GR/8	: A/T device	D1	M110	BR/2	: Center speaker (with BOSE)	
D5	M35	Y/28	: Air bag diagnosis sensor unit	G2	M111	BR/2	: Front tweeter RH	
D4	M39	B/6	: Air mix door motor (driver)	F2	M112	B/24	: BOSE speaker amp.	
B4	M41	W/32	: Automatic drive positioner control unit	F3	M113	GR/8	: BOSE speaker amp.	
B3	M42	W/16	: Automatic drive positioner control unit	F3	M114	W/24	: To B104	
D3	M43	W/10	: Audio unit	G2	M115	W/4	: To B105	
E3	M44	W/6	: Audio unit	B3	M116	GR/8	: Rear sonar system OFF switch	
D3	M45†	W/8	: Audio unit (with base audio system)	D1	M117	B/2	: Sonar buzzer	
D3	M45† †	W/6	: Audio unit (except base audio system)	G2	M120	W/4	: Remote keyless entry receiver	
D3	M46	W/20	: Audio unit	E3	M122	GR/4	: Variable blower control	
B2	M47	W/8	: Steering angle sensor	C3	M123	W/2	: Tire pressure warning check connector	
E2	M48	BR/2	: To M501	E3	M127	W/12	: Audio unit (with satellite radio tuner)	
D2	M49	B/26	: Front air control	E3	M128	W/16	: Satellite radio tuner	
E3	M50	L/24	: Front air control					

HARNESS

ENGINE ROOM HARNESS (RH VIEW)

Engine Compartment

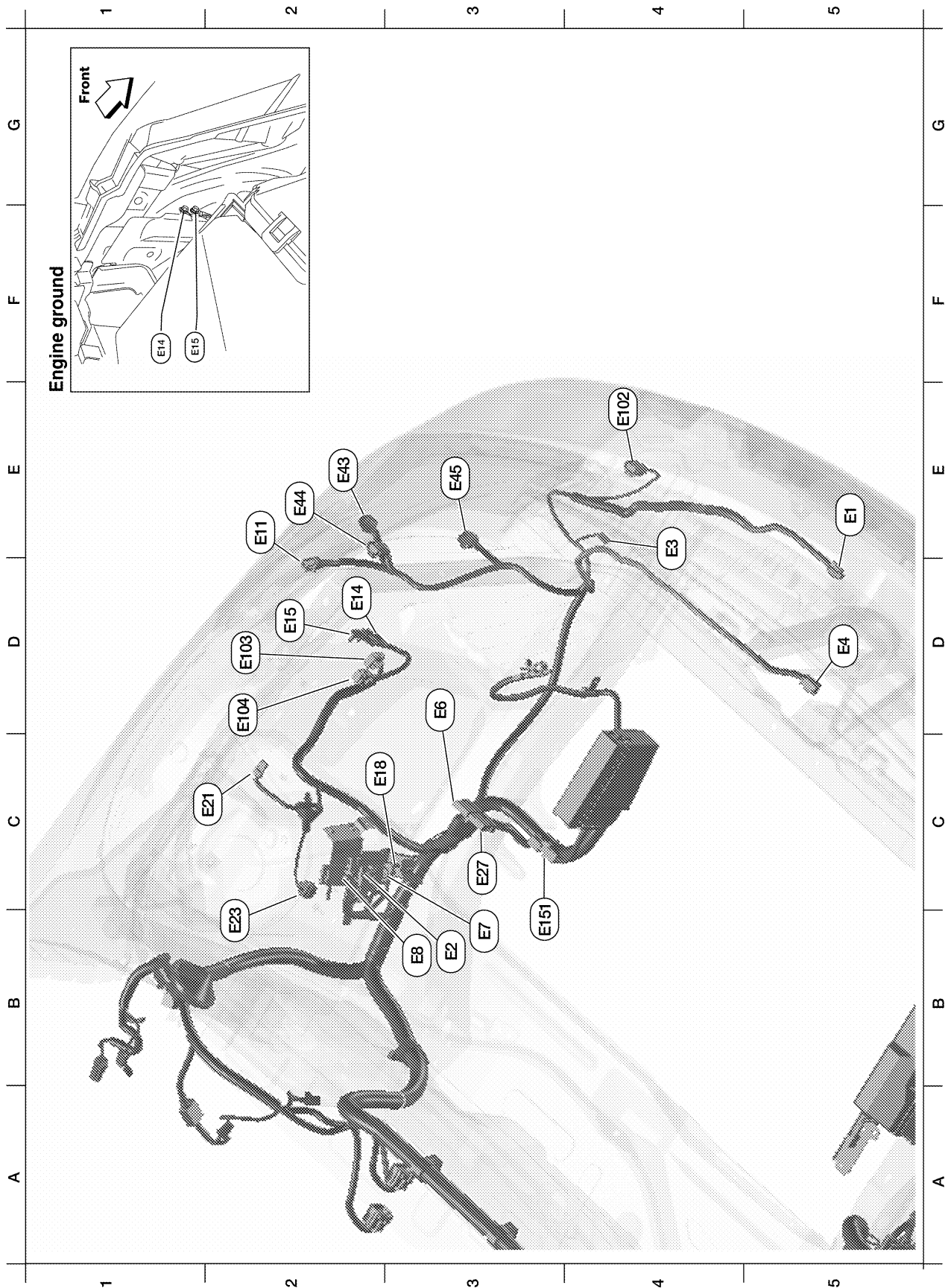

Refer to [PG-53, "ENGINE ROOM HARNESS \(LH VIEW\)"](#) for continuation of engine room harness.

HARNESS

Passenger Compartment

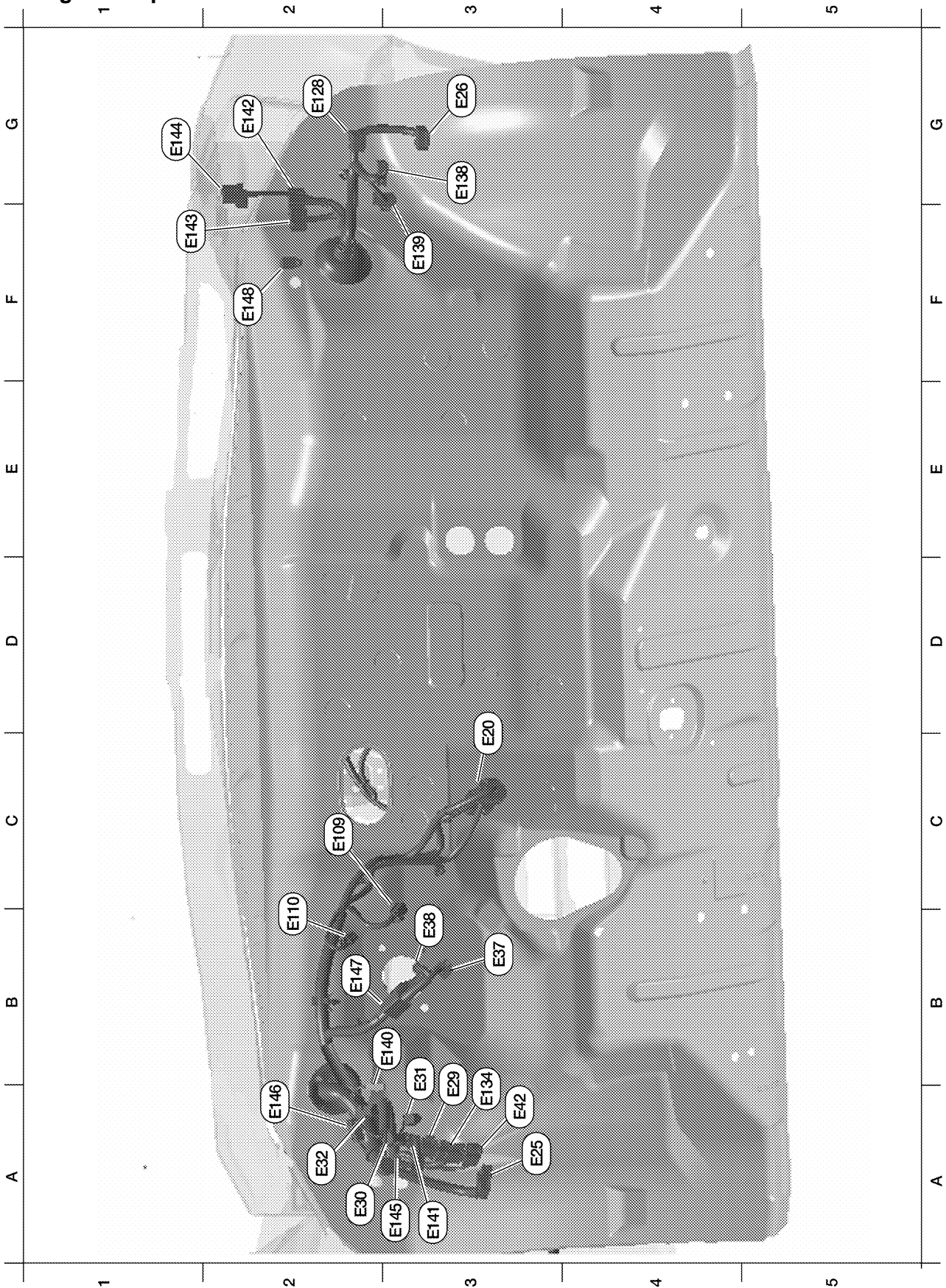

WKIA5384E

HARNESS

Passenger compartment							
C3	E20	B/8	: Accelerator pedal position (APP) sensor				
A3	E25	W/24	: To M90				
G3	E26	BR/16	: To M91				
B3	E29	W/4	: To M10				
A2	E30	W/8	: Fuse block (J/B)				
A3	E31	B/2	: Fuse block (J/B)				
A2	E32	B/1	: Fuse block (J/B)				
B3	E37	BR/2	: ASCD brake switch				
B3	E38	W/4	: Stop lamp switch				
A3	E42	Y/4	: To M88				
C2	E109	GR/2	: Pedal adjusting motor				
C2	E110	W/3	: Pedal adjusting motor				
G2	E128	L/4	: Heater pump relay				
A3	E134	W/12	: To M83				
G3	E138	W/20	: To B106				
F3	E139	W/6	: To B107				
B3	E140	B/1	: Park brake switch				
A3	E141	W/2	: To B40				
G2	E142	GR/28	: TCM				
F1	E143	GR/20	: TCM				
G1	E144	L/4	: A/T PV IGN relay				
A3	E145	W/8	: To B41				
A2	E146	/3	: Diode-3				
B2	E147	/2	: Diode-1				
F2	E148	W/3	: Daytime light relay				

HARNESSES

D2	E5	B/8	: To F14				
E2	E9	—	: Engine ground				
D3	E12	BR/2	: Front combination lamp RH (head-lamp low)				
D4	E13	B/2	: Front combination lamp RH (head-lamp high)				
E2	E16	B/32	: ECM				
D2	E19	GR/9	: To F33				
D2	E24	—	: Engine ground				
D5	E101	B/2	: Front fog lamp RH				
D4	E105	GR/2	: Washer motor				
D5	E106	BR/2	: Washer fluid level switch				
D2	E107	GR/3	: Front combination lamp RH				
D5	E108	B/1	: Horn (high)				
E5	E111	B/3	: Refrigerant pressure sensor				
F4	E112	—	: Generator				
F5	E113	GR/4	: Cooling fan motor-1				
F5	E114	GR/4	: Cooling fan motor-2				
D3	E116	—	: Body ground (generator)				
F3	E117	GR/2	: Front wheel sensor RH				
E3	E118	B/4	: IPDM E/R (Intelligent Power Distribution Module Engine Room)				
E3	E119	W/4	: IPDM E/R (Intelligent Power Distribution Module Engine Room)				
E3	E120	B/2	: IPDM E/R (Intelligent Power Distribution Module Engine Room)				
E4	E121	W/16	: IPDM E/R (Intelligent Power Distribution Module Engine Room)				
E4	E122	GR/16	: IPDM E/R (Intelligent Power Distribution Module Engine Room)				
E3	E123	W/6	: IPDM E/R (Intelligent Power Distribution Module Engine Room)				
E4	E124	W/12	: IPDM E/R (Intelligent Power Distribution Module Engine Room)				
F2	E125	B/32	: ABS actuator and electric unit (control unit) (without VDC)				
F2	E125	B/46	: ABS actuator and electric unit (control unit) (with VDC)				
F3	E126	—	: Engine ground				
G2	E127	B/2	: Heater pump				
C3	E137	GR/2	: Front combination lamp RH (cornering lamp)				

HARNESS

ENGINE CONTROL HARNESS

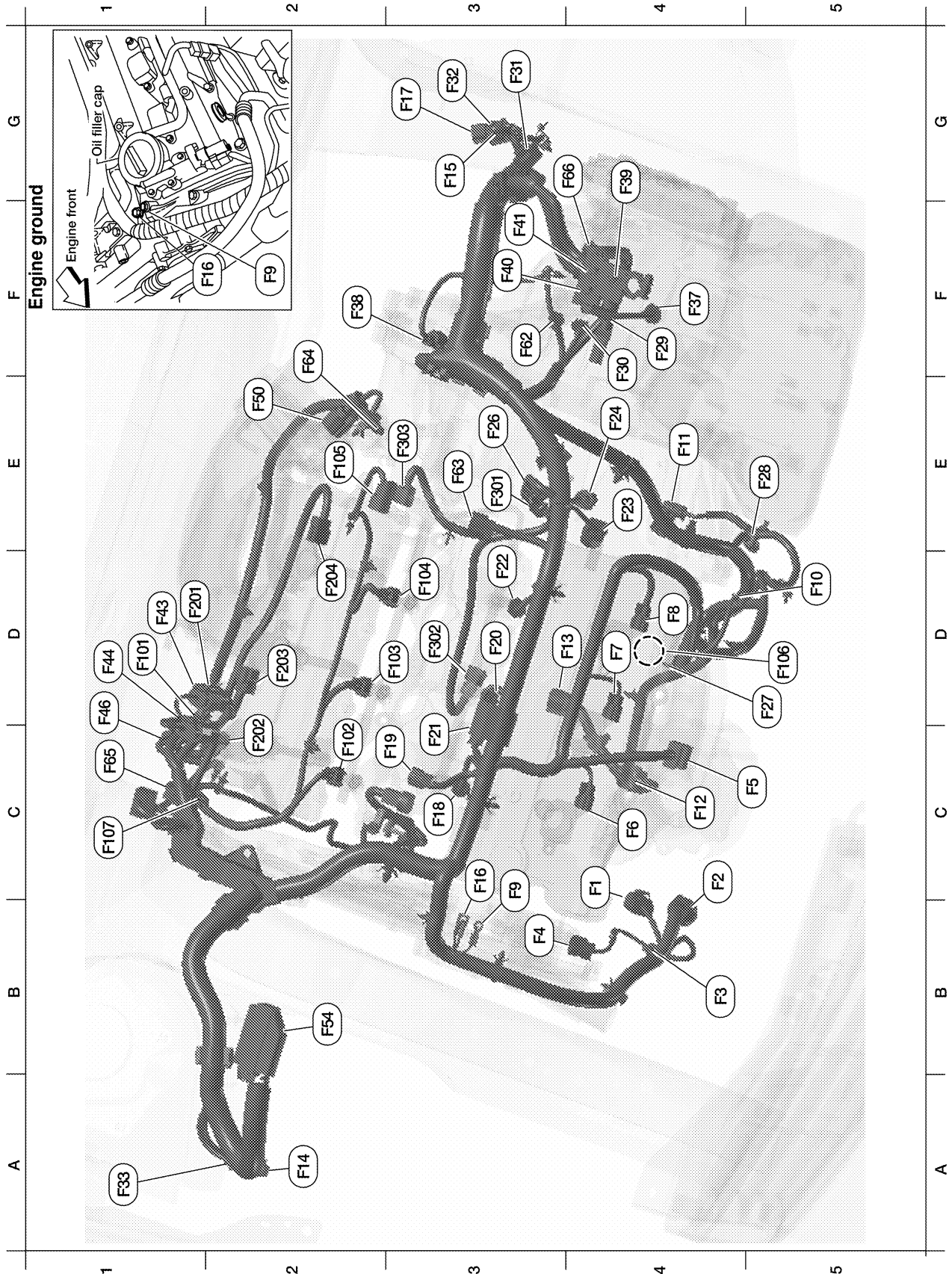

A
B
C
D
E
F
G
H
I
J
K
L
M

PG

WKIA5386E

HARNESS

B4	F1	W/2	: Generator	D1	F44	G/8	: To F101
C4	F2	—	: Generator	D1	F46	B/3	: Power steering pressure sensor
B4	F3	B/1	: Mass air flow sensor	E2	F50	GR/6	: Electric throttle control actuator
B3	F4	G/2	: Intake valve timing control solenoid valve (Bank 2)	B2	F54	B/76	: ECM
C5	F5	B/6	: Air fuel ratio (A/F) sensor (Bank 2)	F3	F62	GR/6	: Terminal cord assembly
C4	F6	GR/3	: Ignition coil No. 2 (with power transistor)	E3	F63	GR/2	: EGR temperature sensor
D4	F7	GR/3	: Ignition coil No. 4 (with power transistor)	F2	F64	GR/6	: EGR volume control valve
D4	F8	GR/3	: Ignition coil No. 6 (with power transistor)	C1	F65	B/6	: Air fuel ratio (A/F) sensor (Bank 1)
B3	F9	—	: Engine ground	G4	F66	B/1	: To E151
D5	F10	BR/3	: Front electronic controlled engine mount	Engine control sub-harness-1			
E4	F11	B/3	: Crankshaft position sensor (POS)	D1	F101	G/8	: To F44
C4	F12	L/4	: Heated oxygen sensor 2 (Bank 2)	C2	F102	GR/2	: Fuel injector No. 1
D3	F13	G/4	: Heated oxygen sensor 2 (Bank 1)	D2	F103	GR/2	: Fuel injector No. 3
A2	F14	B/8	: To E5	D3	F104	GR/2	: Fuel injector No. 5
G3	F15	G/10	: To E7	E2	F105	L/2	: EVAP canister purge volume control solenoid valve
C3	F16	—	: Engine ground	D5	F106	B/1	: Oil pressure switch
G3	F17	B/12	: To E8	C1	F107	G/2	: Intake valve timing control solenoid valve (Bank-1)
C3	F18	GR/2	: Fuel injector No. 2	Engine control sub-harness-2			
C3	F19	B/2	: VIAS control solenoid valve	D1	F201	G/6	: To F43
D3	F20	GR/2	: Fuel injector No. 4	C2	F202	GR/3	: Ignition coil No. 1 (with power transistor)
C3	F21	W/2	: Condenser-1	D2	F203	GR/3	: Ignition coil No. 3 (with power transistor)
D3	F22	GR/2	: Fuel injector No. 6	D2	F204	GR/3	: Ignition coil No. 5 (with power transistor)
E4	F23	B/3	: Camshaft position sensor (PHASE) (Bank 2)	Engine control sub-harness-3			
E4	F24	GR/2	: Engine coolant temperature sensor	E3	F301	GR/6	: To F26
E3	F26	GR/6	: To F301	D3	F302	B/2	: Knock sensor
D5	F27	—	: Starter motor	E3	F303	G/3	: Camshaft position sensor (PHASE) (Bank 1)
E5	F28	GR/1	: Starter motor				
F4	F29	GR/10	: Park/neutral position (PNP) switch				
F4	F30	BR/8	: Terminal cord assembly				
G3	F31	B/6	: Mass air flow sensor				
G3	F32	GR/10	: To E2				
A1	F33	GR/9	: To E19				
F4	F37	L/2	: Turbine revolution sensor				
F2	F38	L/2	: Revolution sensor				
G4	F39	—	: Fusible link box (battery)				
F3	F40	—	: Fusible link box (battery)				
F3	F41	—	: Fusible link box (battery)				
D1	F43	G/6	: To F201				

HARNESS

BODY HARNESS

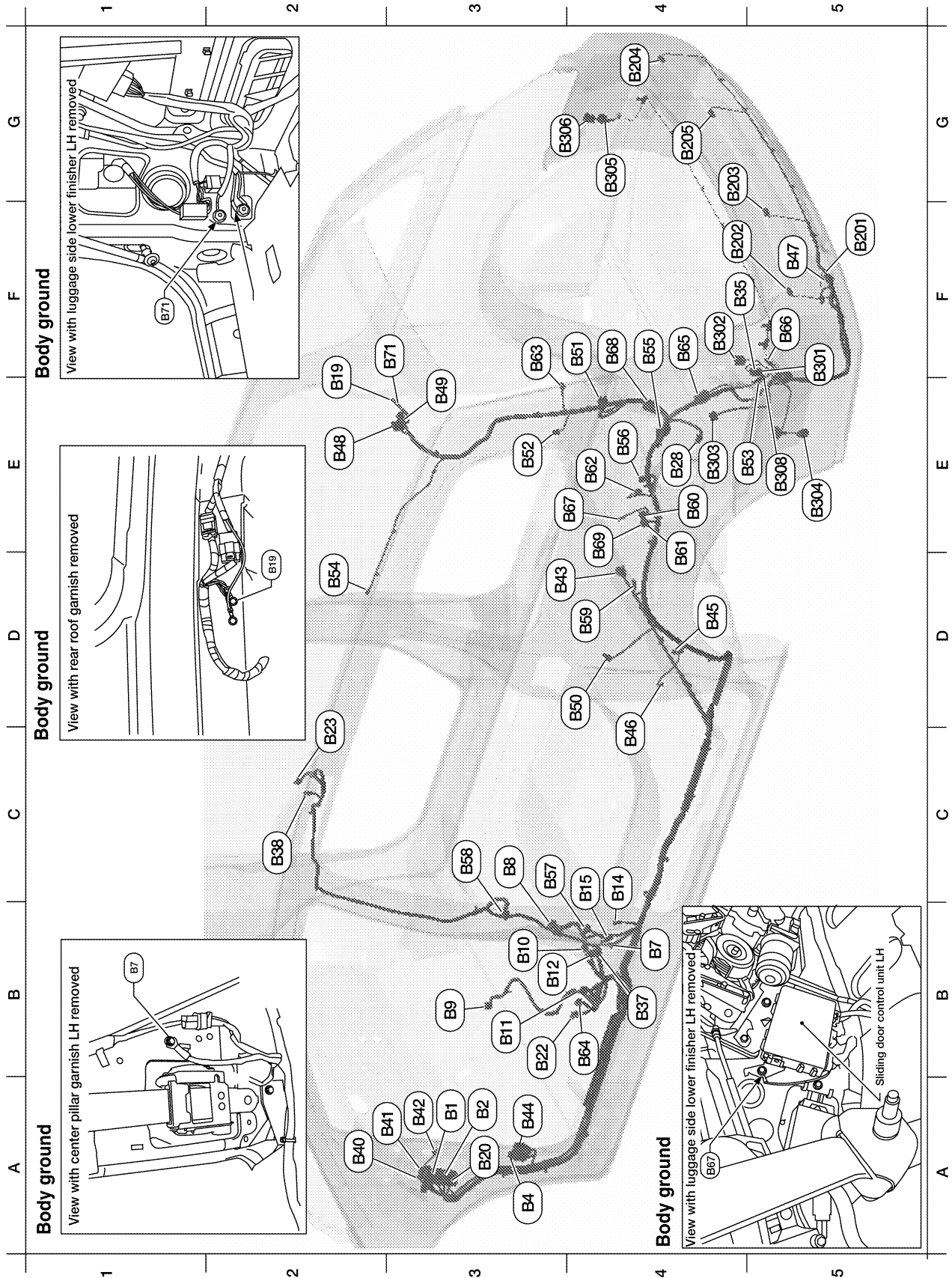

WKIA5387E

HARNESSES

A3	B1	W/16	: To M11	C3	B58	W/4	: Sliding door open/close switch LH
A3	B2	GR/24	: To M12	D4	B59	W/4	: Sliding door motor assembly LH (sliding door encoder)
A3	B4	BR/6	: Rear window defogger relay	E4	B60	W/24	: Sliding door control unit LH
B4	B7	—	: Body ground	D4	B61	W/8	: Sliding door control unit LH
C3	B8	W/3	: Front door switch LH	E4	B62	B/2	: Fuel door interlock switch
B3	B9	Y/12	: Air bag diagnosis sensor unit	E3	B63	GR/6	: Back door close switch
B3	B10	Y/2	: Front LH side air bag module	B4	B64	W/6	: Front heated seat switch LH
B3	B11	W/8	: Subwoofer	F4	B65	W/2	: Condenser-3
B3	B12	W/3	: Seat belt buckle switch LH	F5	B66	—	: Body ground
C4	B14	Y/2	: Front LH seat belt pre-tensioner	E4	B67	—	: Body ground
C4	B15	Y/2	: LH side air bag (satellite) sensor	F4	B68	W/2	: Condenser-4
E2	B19	—	: Body ground	D4	B69	W/6	: Sliding door control unit LH
A3	B20	W/16	: To M81	F3	B71	—	: Body ground
B3	B22	BR/6	: Pedal adjusting switch	Rear sonar sensor sub-harness			
C2	B23	W/16	: Rear audio remote control unit	F5	B201	GR/6	: To B47
E4	B28	W/4	: Fuel lid opener actuator	F4	B202	B/3	: Rear sonar sensor LH outer
F4	B35	W/6	: Rear combination lamp LH (without trailer tow)	F4	B203	B/3	: Rear sonar sensor LH inner
F4	B35	W/6	: To D301 (with trailer tow)	G4	B204	B/3	: Rear sonar sensor RH outer
B4	B37	W/16†	: To B400 (with memory seat)	G4	B205	B/3	: Rear sonar sensor RH inner
B4	B37	W/10††	: To B400 (without memory seat)	Trailer tow sub-harness			
B4	B37	W/6	: To B400 (heated seat only)	F5	B301	W/6	: To B35
C2	B38	Y/2	: LH side rear curtain air bag module	F4	B302	W/6	: Rear combination lamp LH (with trailer tow)
A2	B40	W/2	: To E141	E4	B303	W/10	: Trailer tow control unit (with trailer tow)
A3	B41	W/8	: To E145	E5	B304	GR/4	: Trailer (with trailer tow)
A3	B42	W/6	: Fuse block (J/B)	G4	B305	W/6	: To B130
D4	B43	W/10	: To B111	G3	B306	W/6	: Rear combination lamp RH (with trailer tow)
A3	B44	W/2	: Circuit breaker-2	E5	B308	W/1	: To B53
D4	B45	W/2	: Rear speaker LH				
C4	B46	W/3	: Sliding door switch LH				
C5	B47	GR/6	: To B201				
E2	B48	W/12	: To D401 (without power back door)				
E2	B48	W/24	: To D401 (with power back door)				
E3	B49	W/4	: To D402				
D4	B50	B/3	: Rear power socket (2nd row)				
F4	B51	B/3	: Rear power socket (cargo)				
E3	B52	W/2	: Rear power vent window motor LH				
E5	B53	W/1	: To B308				
D2	B54	Y/2	: LH side front curtain air bag module				
F4	B55	W/26	: Back door control unit				
E4	B56	W/16	: Sonar control unit				
C3	B57	W/8	: Sliding door contact switch LH (pillar)				

HARNESSES

BODY NO. 2 HARNESS

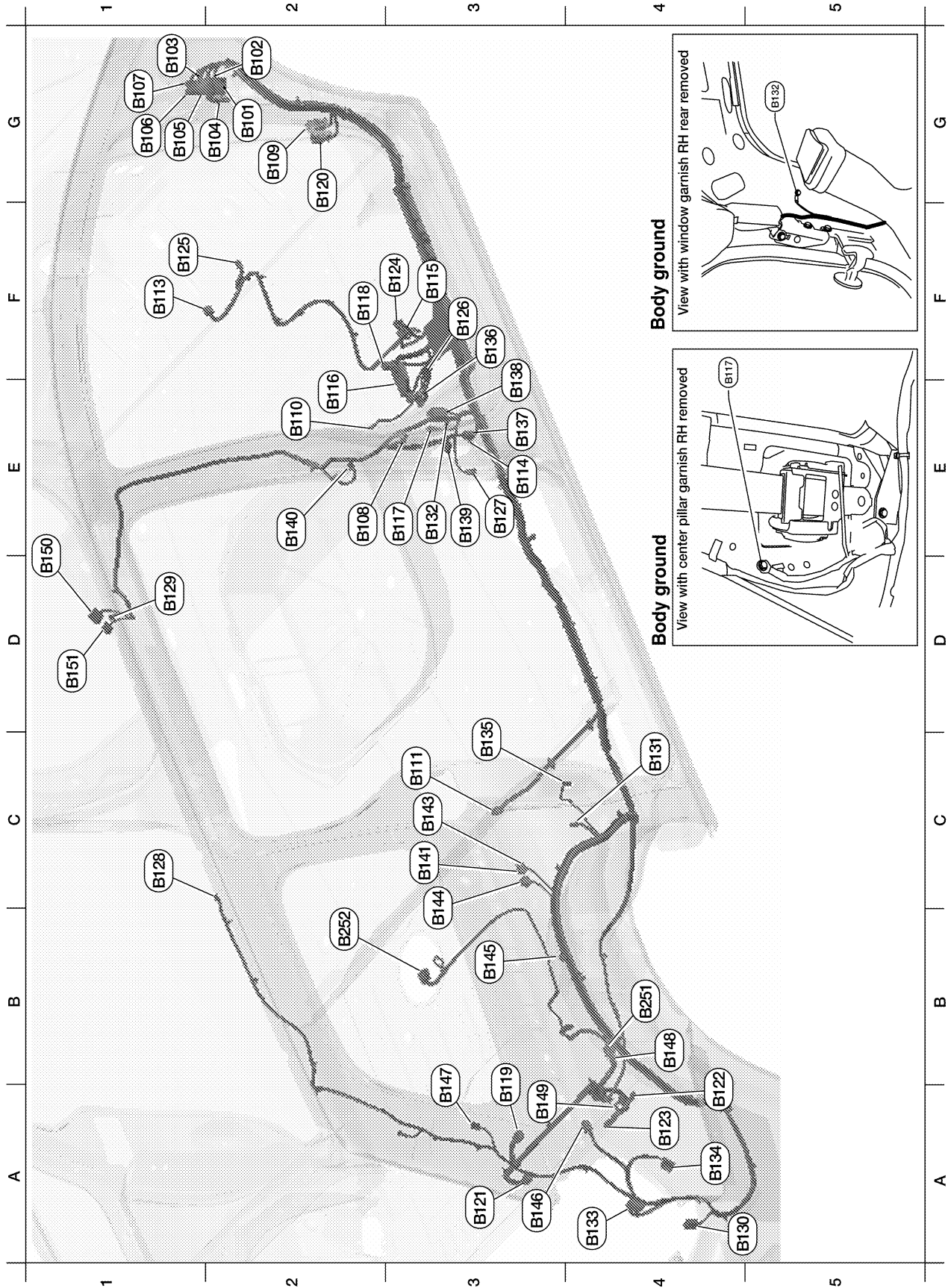

WKIA5388E

A
B
C
D
E
F
G
H
I
J
PG
L
M

HARNESSES

G2	B101	W/16	: To M84	B3	B144	W/8	: Sliding door control unit RH
G2	B102	BR/24	: To M85	B3	B145	W/4	: Sliding door motor assembly RH (sliding door encoder)
G1	B103	BR/20	: To M86	A3	B146	B/6	: Air mix door (rear)
G2	B104	W/24	: To M114	B3	B147	W/2	: Rear power vent window motor RH
G1	B105	W/4	: To M115	B4	B148	GR/6	: To B251
G1	B106	W/20	: To E138	A3	B149	GR/2	: Running board lamps pre-wiring
G1	B107	W/6	: To E139	E1	B150	B/10	: Rear air control (rear)
E2	B108	W/3	: Front door switch RH	D1	B151	W/4	: Variable blower control (rear)
G2	B109	L/4	: Heated seat relay	C3	B141	W/6	: Sliding door control unit RH
E2	B110	W/3	: Seat belt buckle switch RH	Fuel tank sub-harness			
C3	B111	W/10	: To B43	B4	B251	GR/6	: To B148
F1	B113	Y/12	: Air bag diagnosis sensor unit	B2	B252	GR/5	: Fuel level sensor unit and fuel pump
E3	B114	Y/2	: RH side air bag (satellite) sensor				
F3	B115	W/6	: To B501				
E2	B116	W/48	: To B502				
E2	B117	—	: Body ground				
F2	B118	W/12	: To B503				
B3	B119	GR/3	: EVAP control system pressure sensor				
G2	B120	W/2	: Circuit breaker-1				
A3	B121	B/2	: EVAP canister vent control valve				
B4	B122	GR/2	: Rear wheel sensor RH				
A4	B123	L/2	: Rear wheel sensor LH				
F3	B124	BR/6	: Front heated seat switch RH				
F1	B125	B/6	: Yaw rate/side/decel G-sensor				
F3	B126	Y/2	: Front RH side air bag module				
E3	B127	Y/2	: Front RH seat belt pre-tensioner				
C1	B128	Y/2	: RH side rear curtain air bag module				
D1	B129	Y/2	: RH side front curtain air bag module				
A4	B130	W/6	: Rear combination lamp RH (without trailer tow)				
A4	B130	W/6	: To B305 (with trailer tow)				
C4	B131	W/2	: Rear speaker RH				
E3	B132	—	: Body ground				
A4	B133	W/4	: Rear blower motor resistor				
A4	B134	W/2	: Rear blower motor				
C3	B135	W/3	: Sliding door switch RH				
F3	B136	W/8	: To B508				
E3	B137	B/3	: Belt tension sensor				
E3	B138	W/2	: Condenser-2				
E3	B139	W/8	: Sliding door contact switch RH (pillar)				
E2	B140	W/4	: Sliding door open/close switch RH				
C3	B143	W/24	: Sliding door control unit RH				

HARNESS

ROOM LAMP HARNESS

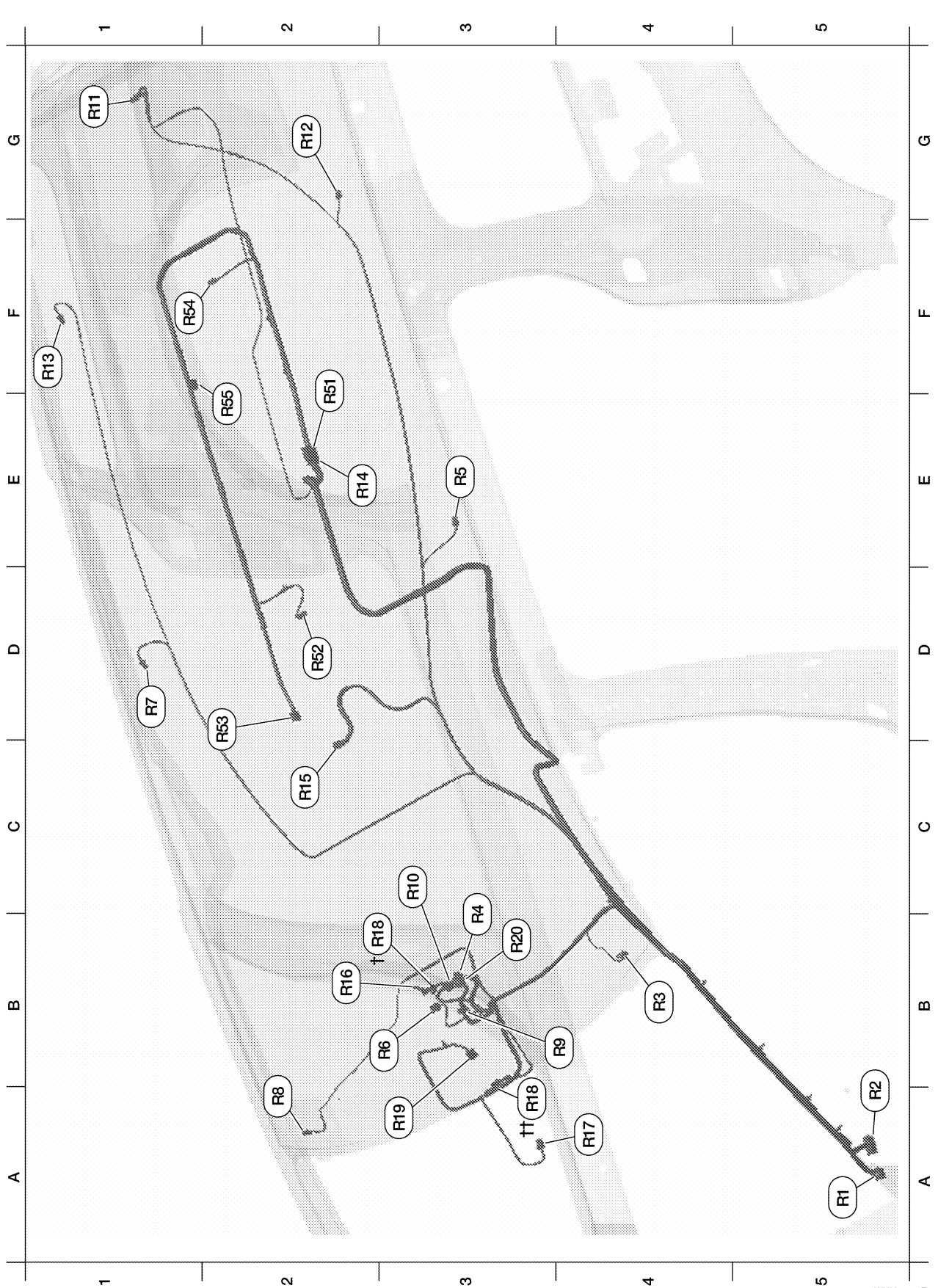

WKIA5389E

HARNESSES

A5	R1	W/16	: To M1				
A5	R2	W/32	: To M2				
B4	R3	W/2	: Vanity lamp LH				
B3	R4	W/10	: Sunroof motor assembly				
E3	R5	W/3	: Personal lamp 2nd row LH (without rear roof console)				
B2	R6	GR/6	: Sunroof switch				
D1	R7	W/3	: Personal lamp 2nd row RH (without rear roof console)				
A2	R8	W/2	: Vanity lamp RH				
B3	R9	W/3	: Room/map lamps				
C3	R10	W/8	: Automatic door main switch				
G1	R11	W/3	: Cargo lamp				
F2	R12	W/3	: Personal lamp 3rd row LH (without rear roof console)				
F1	R13	W/3	: Personal lamp 3rd row RH (without rear roof console)				
E2	R14	W/4	: To R51 (without DVD entertainment system)				
E2	R14	W/24	: To R51 (with DVD entertainment system)				
C2	R15	W/12	: Video monitor (with DVD entertainment system except models with overhead console)				
B2	R16	W/4	: Bluetooth ON indicator				
A4	R17	B/10	: Auto anti-dazzling inside mirror				
A3	R18†	W/2	: Console lamp (without power sliding door)				
A3	R18† †	W/2	: Console lamp				
A3	R19	B/10	: Rear air control (front)				
B3	R20	W/4	: Microphone				
Overhead console harness							
E2	R51	W/4	: To R14 (without DVD entertainment system)				
E2	R51	W/24	: To R14 (with DVD entertainment system)				
D2	R52	W/3	: Personal lamp 2nd row (with rear roof console)				
C2	R53	W/12	: Front video monitor				
F1	R54	W/3	: Personal lamp 3rd row (with rear roof console)				
E2	R55	W/12	: Rear video monitor (with dual monitor DVD entertainment system)				

HARNESS

FRONT DOOR HARNESS LH

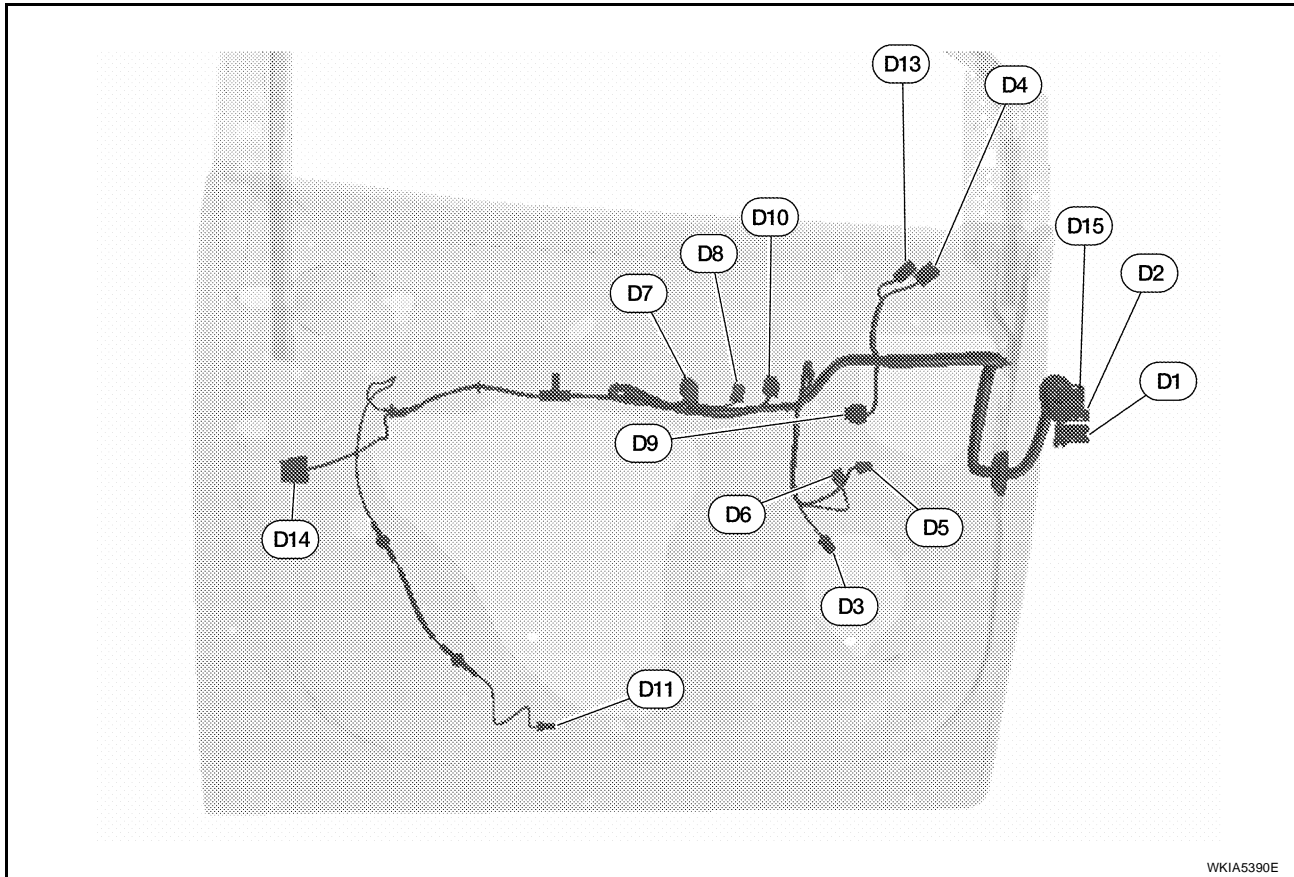

WKIA5390E

D1	GR/12	: To M9	D8	W/3	: Main power window and door lock/ unlock switch
D2	W/12	: To M8	D9	GR/6	: Front power window motor LH
D3	W/2	: Front door speaker LH (without BOSE audio system)	D10	W/10	: Door mirror remote control switch
D3	BR/2	: Front door speaker LH (with BOSE audio system)	D11	W/2	: Front step lamp LH
D4	W/8	: Door mirror LH	D13	W/6	: Door mirror LH
D5	W/8	: Seat memory switch	D14	B/6	: Front door lock assembly LH
D6	W/4	: Fuel lid open switch	D15	W/20	: To M15
D7	W/16	: Main power window and door lock/ unlock switch			

A
B
C
D
E
F
G
H
I
J
PG
L
M

HARNESS

FRONT DOOR HARNESS RH

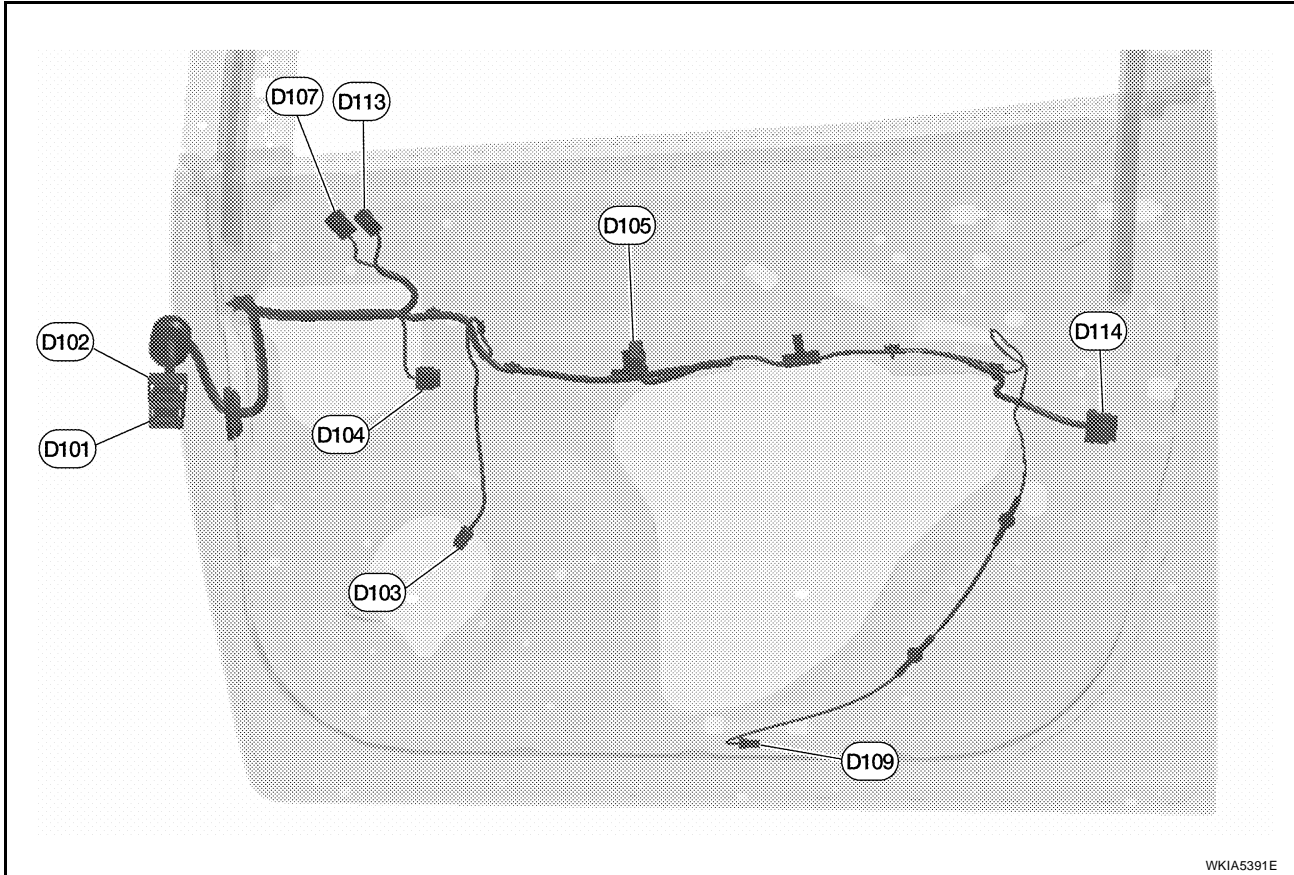

WKIA5391E

D101	W/8	: To M5	D105	W/16	: Power window and door lock/unlock switch RH)
D102	W/16	: To M74	D107	W/8	: Door mirror RH
D103	W/2	: Front door speaker RH (without BOSE audio system)	D109	W/2	: Front step lamp RH
D103	BR/2	: Front door speaker RH (with BOSE audio system)	D113	W/6	: Door mirror RH
D104	GR/6	: Front power window motor RH	D114	B/6	: Front door lock actuator RH

HARNESS

SLIDING DOOR HARNESS LH

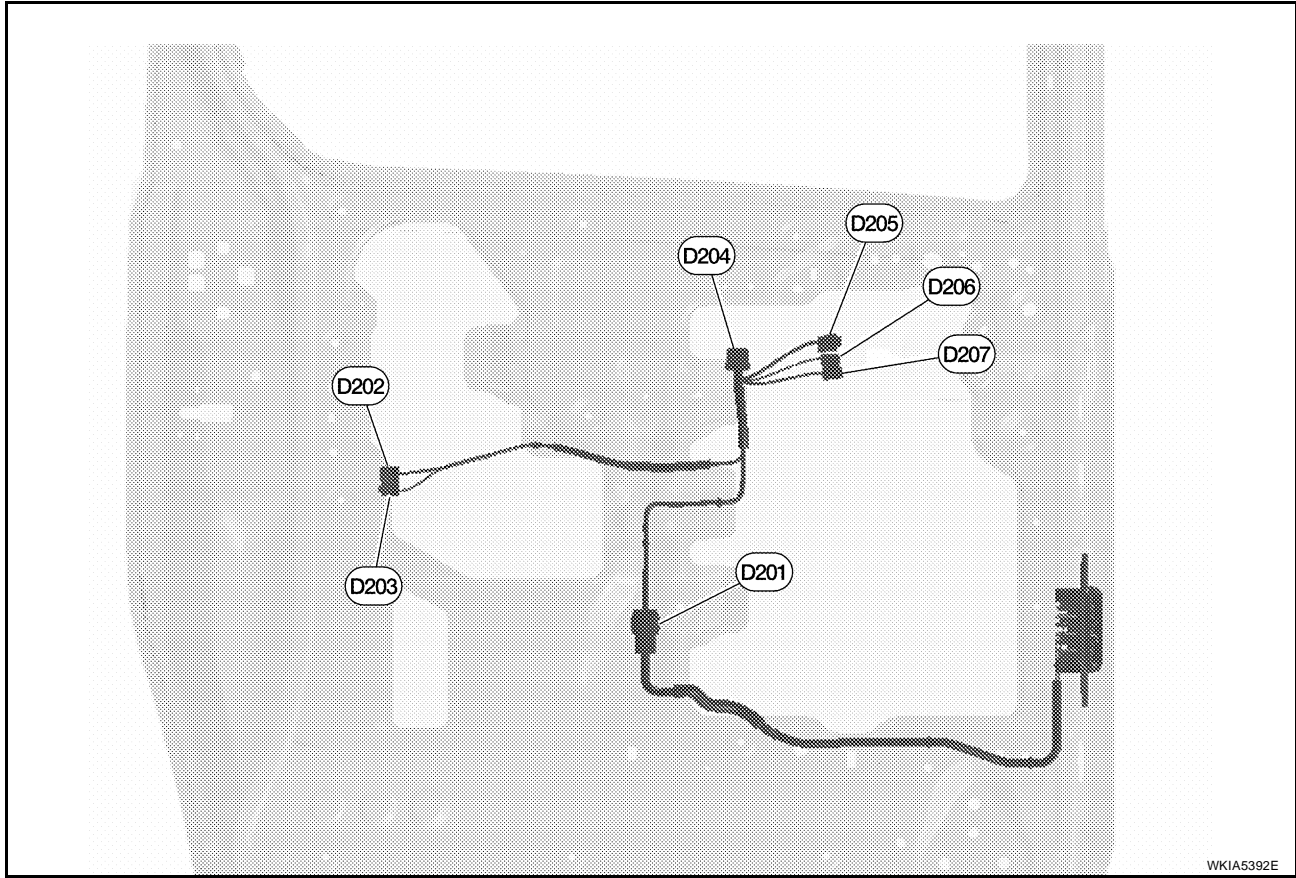

D201	GR/8	: Sliding door contact switch LH	D205	GR/4	: Sliding door lock actuator LH
D202	W/4	: Cinch latch switch LH	D206	W/2	: Latch release actuator LH
D203	W/2	: Cinch latch Motor LH	D207	W/3	: Sliding door remote control switch LH
D204	W/10	: Sliding door latch control unit LH			

A
B
C
D
E
F
G
H
I
J
PG
L
M

HARNESS

SLIDING DOOR HARNESS RH

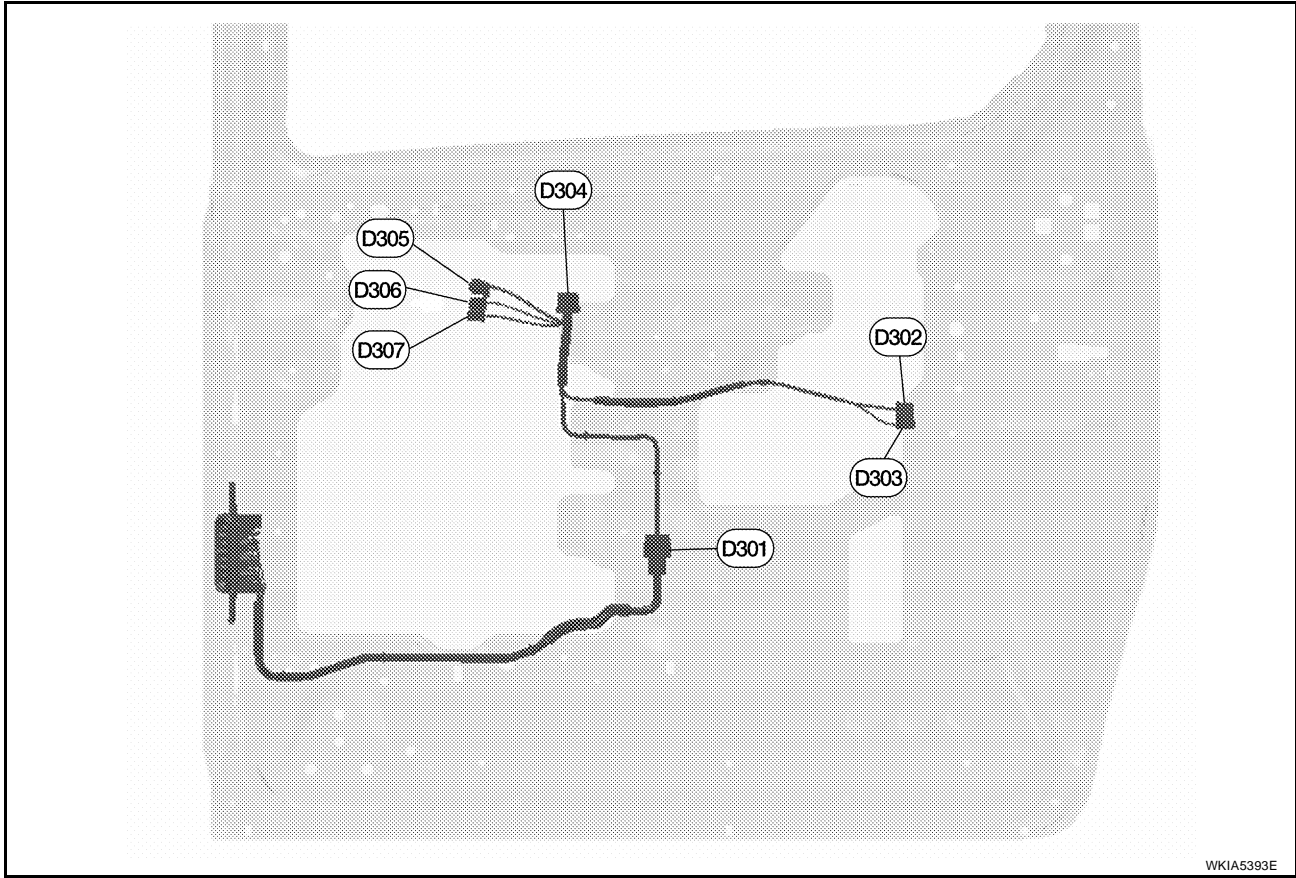

WKIA5393E

D301	GR/8	: Sliding door contact switch RH	D305	GR/4	: Sliding door lock actuator RH
D302	W/4	: Cinch latch switch LH	D306	W/2	: Latch release actuator RH
D303	W/2	: Cinch latch Motor LH	D307	W/3	: Sliding door remote control switch RH
D304	W/10	: Sliding door latch control unit RH			

HARNESS

BACK DOOR HARNESS

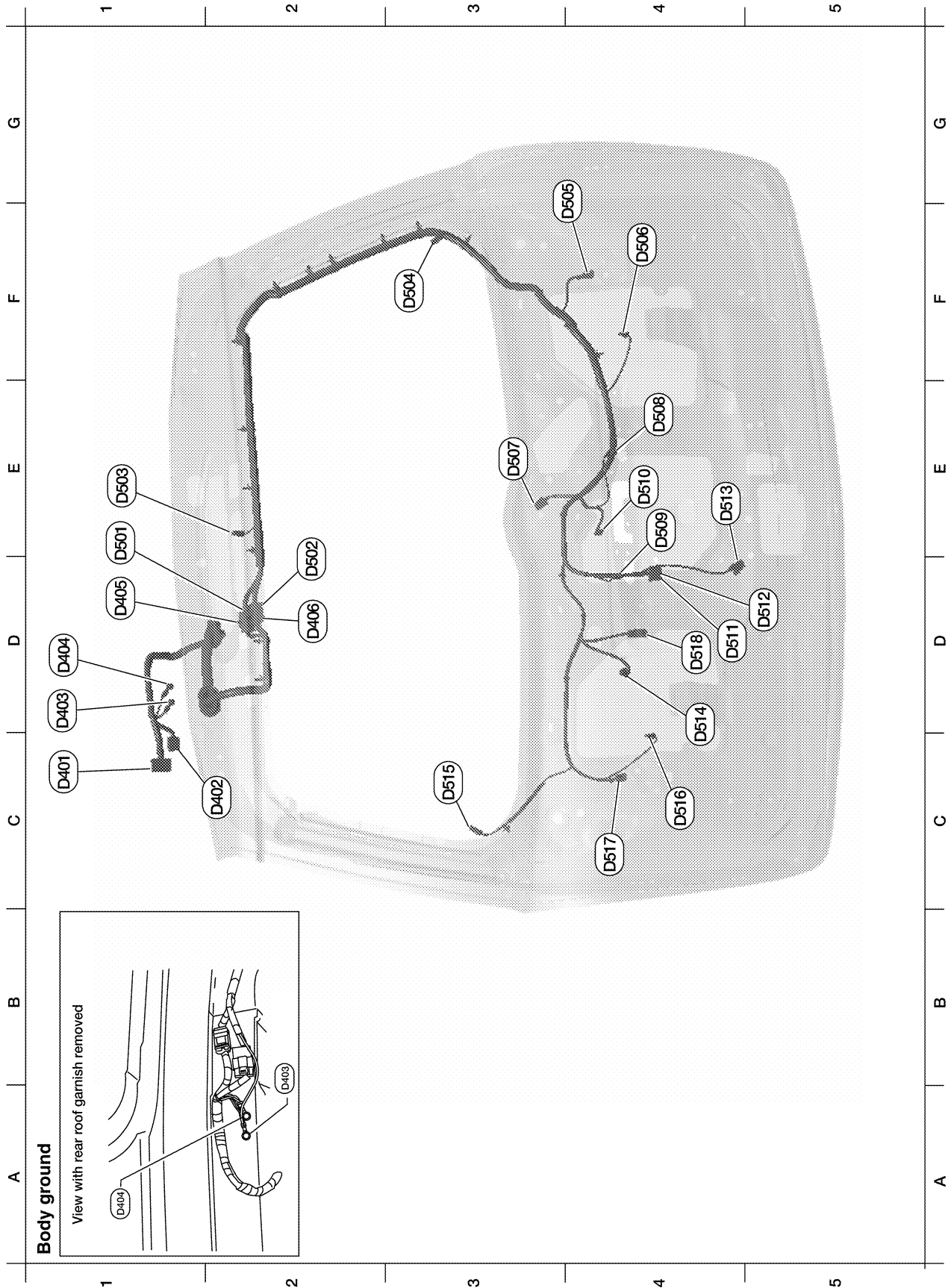

A
B
C
D
E
F
G
H
I
J
K
L
M

PG

WKIA5394E

HARNESSES

Back door No.2 harness							
C1	D401	W/12	: To B48 (without power back door)				
C1	D401	W/24	: To B48 (without power back door)				
C2	D402	W/4	: To B49				
D1	D403	W/2	: Body ground				
D1	D404	W/10	: Body ground				
D1	D405	W/6	: To D501				
D2	D406	W/12	: To D501 (without power back door)				
D2	D406	W/24	: To D501 (with power back door)				
Back door harness							
E1	D501	W/6	: To D405				
E2	D502	W/12	: To D406 (without power back door)				
E2	D502	W/24	: To D406 (with power back door)				
E1	D503	W/2	: High mounted stop lamp				
F3	D504	B/1	: Rear window defogger (+)				
G4	D505	BR/2	: Pinch strip RH				
F4	D506	BR/2	: Rear tweeter RH				
E3	D507	W/4	: Rear wiper motor				
E4	D508	BR/2	: License plate lamp RH				
E4	D509	BR/2	: License plate lamp LH				
E4	D510	GR/2	: Back door handle switch				
D4	D511	W/8	: Back door latch				
D5	D512	W/3	: Back door switch				
E4	D513	W/4	: Back door lock actuator				
D4	D514	BR/2	: Back door warning chime				
C3	D515	B/1	: Rear window defogger (-)				
C4	D516	BR/2	: Rear tweeter LH				
C4	D517	BR/2	: Pinch strip LH				
D4	D518	W/4	: Rear view camera				

HARNESSES

Wiring Diagram Codes (Cell Codes)

EKS00FP3

Use the chart below to find out what each wiring diagram code stands for.

Refer to the wiring diagram code in the alphabetical index to find the location (page number) of each wiring diagram.

Code	Section	Wiring Diagram Name
1STSIG	AT	A/T 1st Signal
2NDSIG	AT	A/T 2nd Signal
3RDSIG	AT	A/T 3rd Signal
4THSIG	AT	A/T 4th Signal
5THSIG	AT	A/T 5th Signal
A/C,A	ATC	Auto Air Conditioner
A/C,M	MTC	Manual Air Conditioner
AF1B1	EC	Air Fuel Ratio Sensor 1 Bank 1
AF1B2	EC	Air Fuel Ratio Sensor 1 Bank 2
AF1HB1	EC	Air Fuel Ratio Sensor 1 Heater Bank 1
AF1HB2	EC	Air Fuel Ratio Sensor 1 Heater Bank 2
APPS1	EC	Accelerator Pedal Position Sensor
APPS2	EC	Accelerator Pedal Position Sensor
APPS3	EC	Accelerator Pedal Position Sensor
ASC/BS	EC	ASCD Brake Switch
ASC/SW	EC	ASCD Steering Switch
ASCBOF	EC	ASCD Brake Switch
ASCIND	EC	ASCD Indicator
AT/IND	DI	A/T Indicator Lamp
AUDIO	AV	Audio
AUT/DP	SE	Automatic Drive Positioner
AUTO/L	LT	Auto Light Control
B/CLOS	BL	Back Door Auto Closure System
BACK/L	LT	Back-up Lamp
BRK/SW	EC	Brake Switch
CAN	AT	CAN Communication Line
CAN	EC	CAN Communication Line
CAN	LAN	CAN System
CHARGE	SC	Charging System
CHIME	DI	Warning Chime
COOL/F	EC	Cooling Fan Control
COMBSW	LT	Combination Switch
COMM	AV	Audio Visual Communication System
CORNER	LT	Cornering Lamps
D/LOCK	BL	Power Door Lock
DEF	GW	Rear Window Defogger
DTRL	LT	Headlamp - With Daytime Light System
DVD	AV	DVD Entertainment System
ECM/PW	EC	ECM Power Supply for Back-Up
ECTS	EC	Engine Coolant Temperature Sensor
EGR/TS	EC	EGR Temperature Sensor
EGRC1	EC	EGR Function
EGVC/V	EC	EGR Volume Control Valve
EMNT	EC	Engine Mount
ETC1	EC	Electric Throttle Control Function
ETC2	EC	Throttle Control Motor Relay
ETC3	EC	Throttle Control Motor

HARNESS

F/FOG	LT	Front Fog Lamp
F/LID	BL	Fuel Lid Opener
F/PUMP	EC	Fuel Pump
FTS	AT	A/T Fluid Temperature Sensor
FTSP	AT	A/T Fluid Temperature Sensor Failure
FTTS	EC	Fuel Tank Temperature Sensor
FUELB1	EC	Fuel Injection System Bank 1
FUELB2	EC	Fuel Injection System Bank 2
H/LAMP	LT	Headlamp
H/PHON	AV	Hands Free Telephone
HORN	WW	Horn
HSEAT	SE	Heated Seat
I/MIRR	GW	Inside Mirror (Auto Anti-Dazzling Mirror)
IATS	EC	Intake Air Temperature Sensor
IGNSYS	EC	Ignition System
ILL	LT	Illumination
INF/D	AV	Vehicle Information and Integrated Switch System
INJECT	EC	Injector
INT/L	LT	Room/Map, Vanity, Cargo, Personal, Foot, Step, Puddle and Running Board Lamps
IVCB1	EC	Intake Valve Timing Control Solenoid Valve Bank 1
IVCB2	EC	Intake Valve Timing Control Solenoid Valve Bank 2
KEYLES	BL	Remote Keyless Entry System
KS	EC	Knock Sensor
LVRSW	AT	A/T Device Lever Switch
MAFS	EC	Mass Air Flow Sensor
MAIN	EC	Main Power Supply and Ground Circuit
METER	DI	Speedometer, Tachometer, Temp. and Fuel Gauges
MIL/DL	EC	Malfunction Indicator Lamp
MIRROR	GW	Door Mirror
NATS	BL	Nissan Anti-Theft System
NAVI	AV	Navigation System
O2H2B1	EC	Rear Heated Oxygen Sensor 2 Heater Bank 1
O2H2B2	EC	Rear Heated Oxygen Sensor 2 Heater Bank 2
O2S2B1	EC	Heated Oxygen Sensor 2 Bank 1
O2S2B2	EC	Heated Oxygen Sensor 2 Bank 2
P/SCKT	WW	Power Socket
PC/A	AT	Line Pressure Solenoid Valve
PC/B	AT	Shift Pressure Solenoid Valve
PC/C	AT	Pressure Control Solenoid Valve
PC/CS	AT	Pressure Control Solenoid Valve Failure
PEDAL	AP	Adjustable Pedal System
PGC/V	EC	EVAP Canister Purge Volume Control Solenoid Valve
PHSB1	EC	Camshaft Position Sensor (PHASE) (Bank 1)
PHSB2	EC	Camshaft Position Sensor (PHASE) (Bank 2)
PNP/SW	AT	Park/Neutral Position Switch
PNP/SW	EC	Park/Neutral Position Switch
POS	EC	Crankshaft Position Sensor (POS)
POWER	PG	Power Supply Routing
PRE/SE	EC	EVAP Control System Pressure Sensor
PS/SEN	EC	Power Steering Pressure Sensor
PWR/IN	AT	TCM Ignition Power

HARNESSES

R/VIEW	DI	Rear View Camera	
RP/SEN	EC	Refrigerant Pressure Sensor	A
S/CLOS	BL	Slide Door Auto Closure System	
SEAT	SE	Power Seat	
SEN/PW	EC	Sensor Power Supply	B
SFTFNC	AT	Unusual Shifting	
SHIFT	AT	A/T Shift Lock System	
SONAR	DI	Rear Sonar System	C
SROOF	RF	Sunroof	
SRS	SRS	Supplemental Restraint System	
SSV/A	AT	Shift Solenoid Valve A	D
SSV/B	AT	Shift Solenoid Valve B	
SSV/C	AT	Shift Solenoid Valve C	
SSV/CS	AT	Shift Solenoid Valve C Failure	E
SSV/D	AT	Shift Solenoid Valve D	
SSV/E	AT	Shift Solenoid Valve E	
START	SC	Starting System	F
STOP/L	LT	Stop Lamp	
T/TOW	LT	Trailer Tow	
T/WARN	WT	Low Tire Pressure Warning System	G
TAIL/L	LT	Parking, License and Tail Lamps	
TCCSIG	AT	A/T TCC Signal (Lock Up)	
TCS	BRC	Traction Control System	H
TPS1	EC	Throttle Position Sensor	
TPS2	EC	Throttle Position Sensor	
TPS3	EC	Throttle Position Sensor	I
TRNSCV	BL	HOMELINK® Universal Transceiver	
TRSC	AT	Turbine Revolution Sensor	J
TURN	LT	Turn Signal and Hazard Warning Lamps	
VDC	BRC	Vehicle Dynamic Control System	
VEHSEC	BL	Vehicle Security (Theft Warning) System	PG
VENT/V	EC	EVAP Canister Vent Control Valve	
VIAS	EC	Variable Air Induction Control System	
VIAS/V	EC	Variable Air Induction Control System Valve	L
VSSATC	AT	Revolution Sensor	
W/ANT	AV	Audio Antenna	
WARN	DI	Warning Lamps	M
WINDOW	GW	Power Window	
WIP/R	WW	Rear Wiper and Washer	
WIPER	WW	Front Wiper and Washer	

ELECTRICAL UNITS LOCATION

PF2:25230

EKS00FP4

ELECTRICAL UNITS LOCATION

Electrical Units Location ENGINE COMPARTMENT

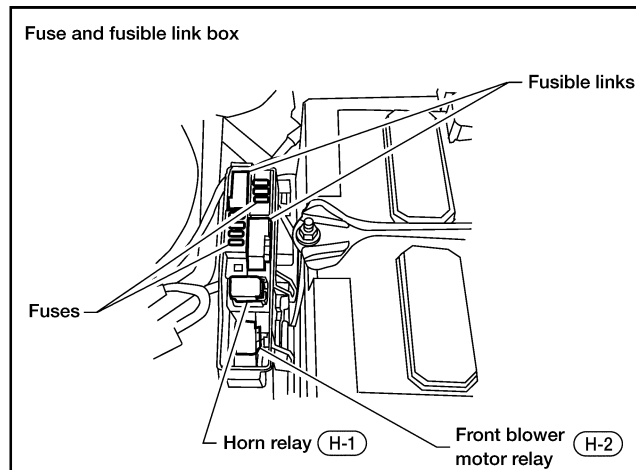
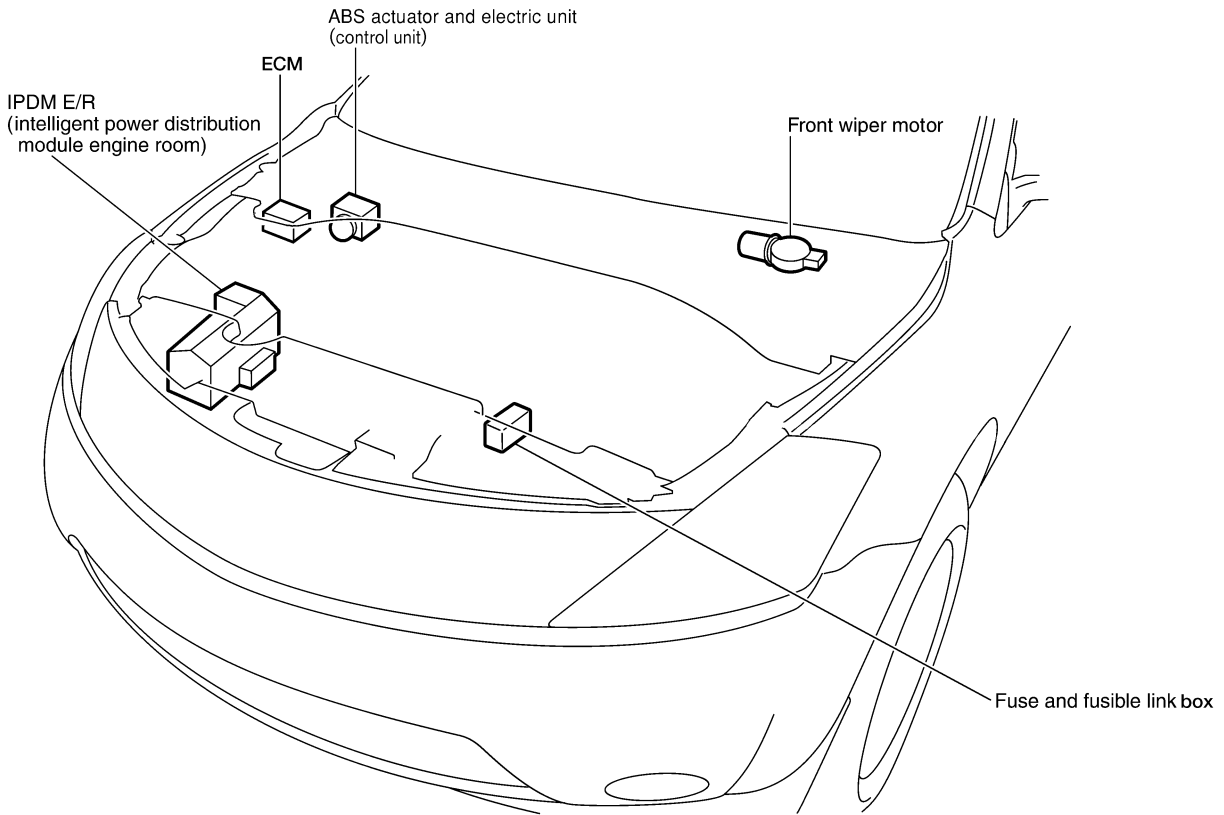

ELECTRICAL UNITS LOCATION

PASSENGER COMPARTMENT

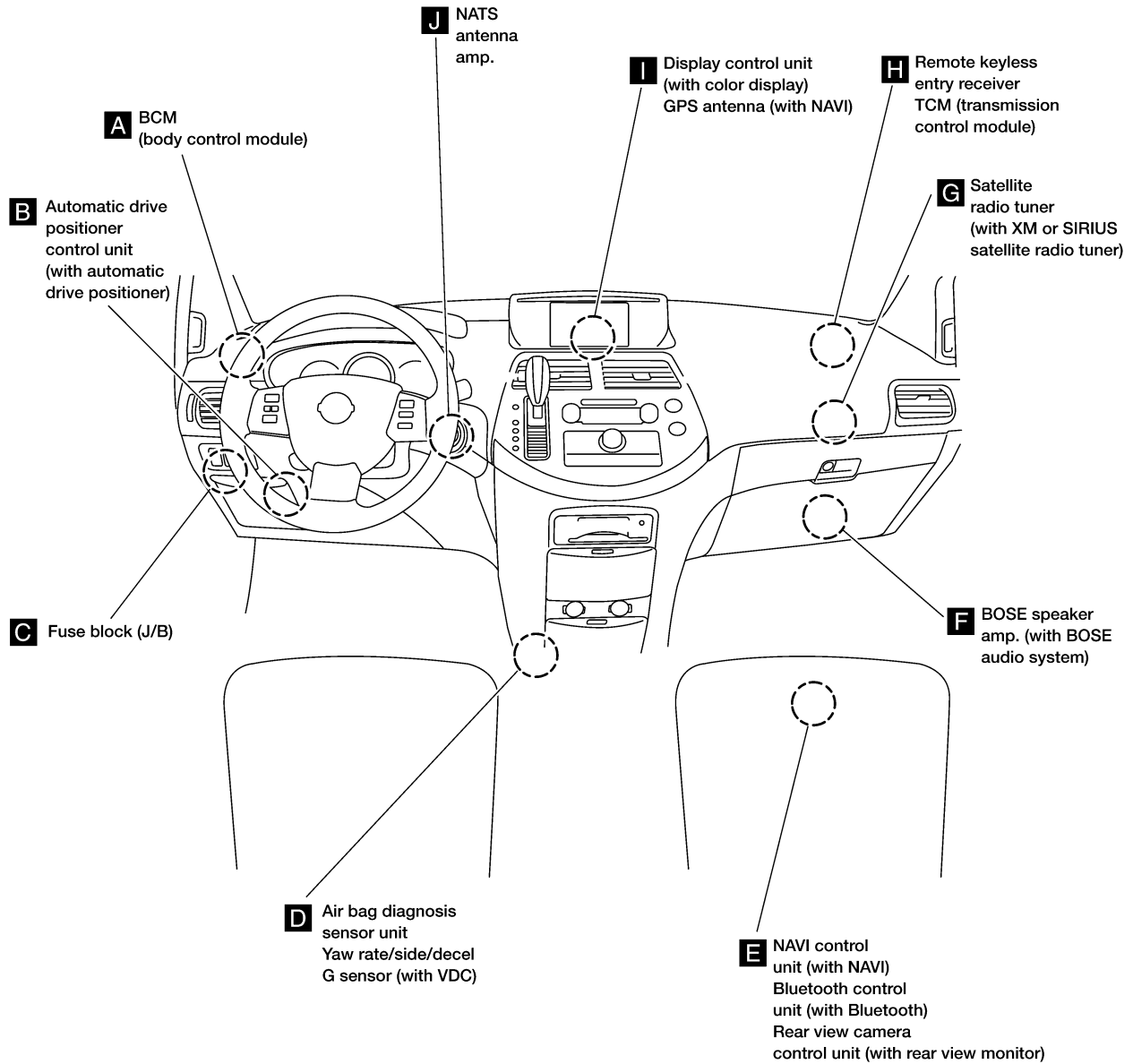

A
B
C
D
E
F
G
H
I
J
PG
L
M

WKIA5242E

ELECTRICAL UNITS LOCATION

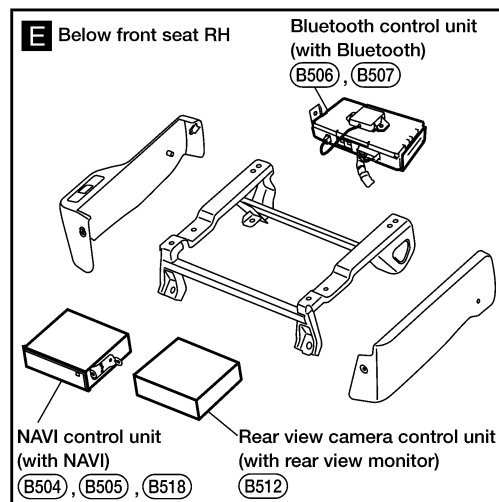
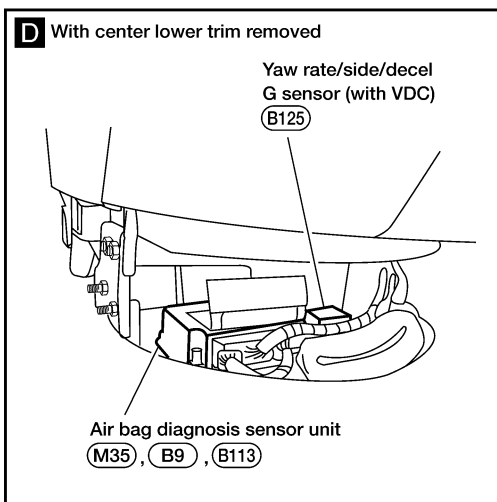
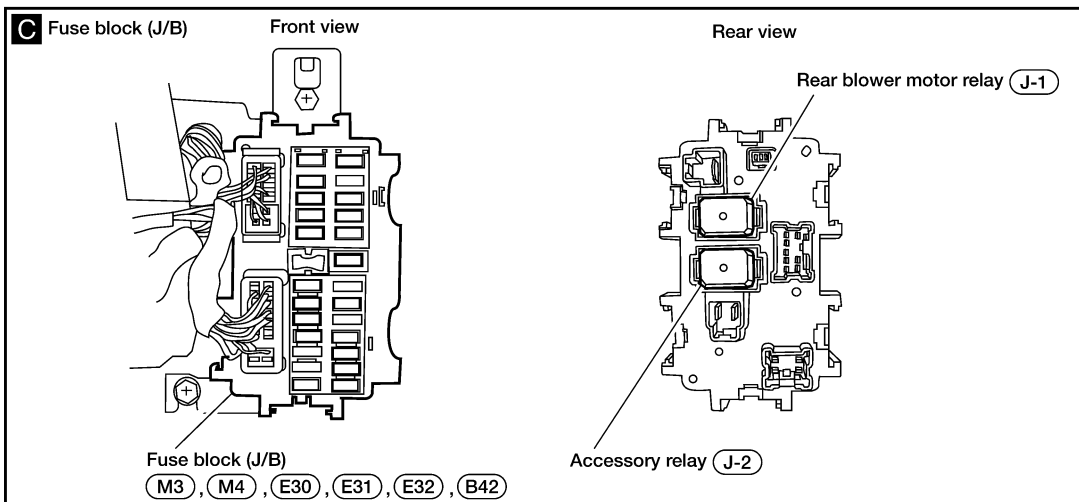
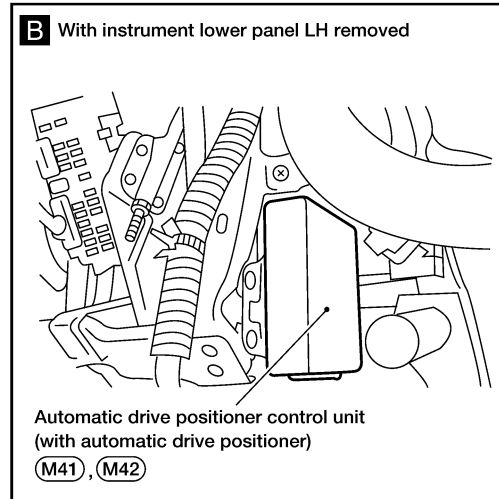
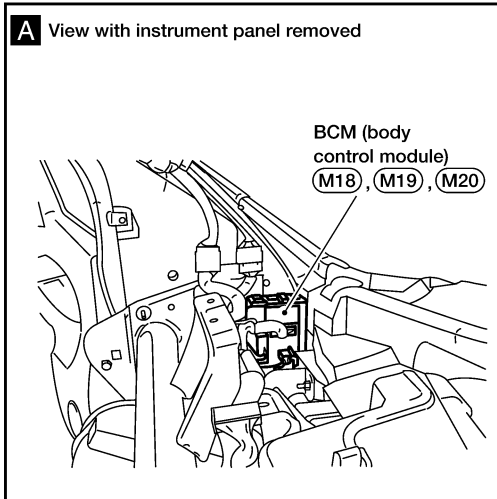

WKIA5245E

ELECTRICAL UNITS LOCATION

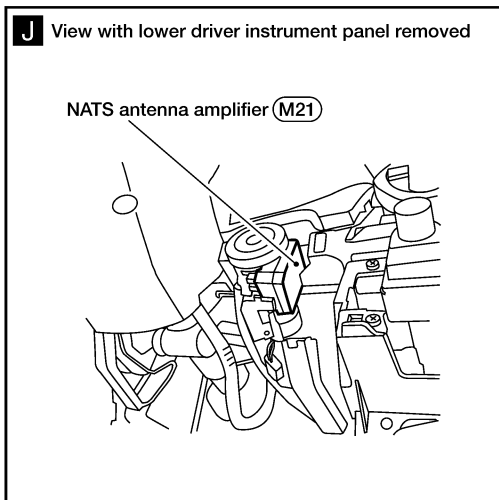
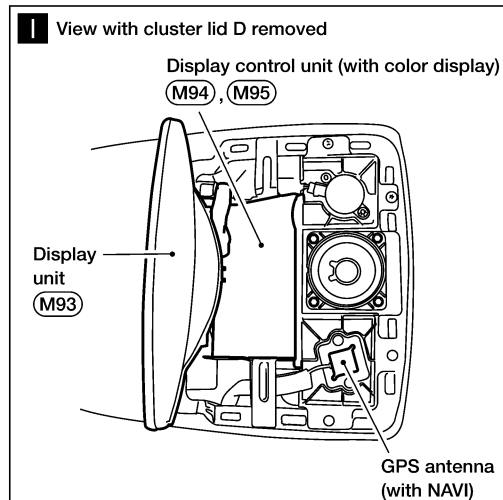
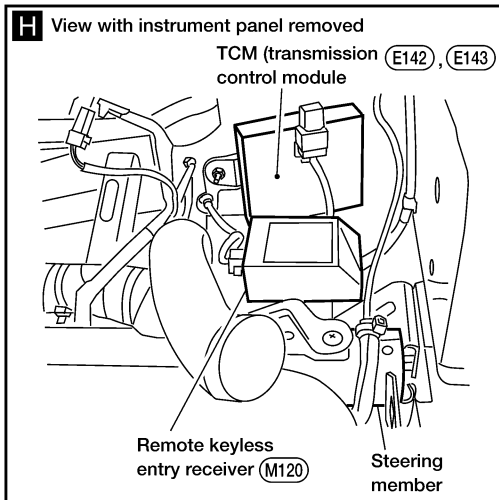
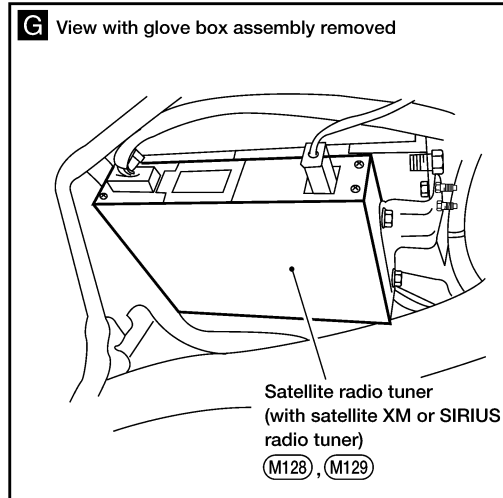
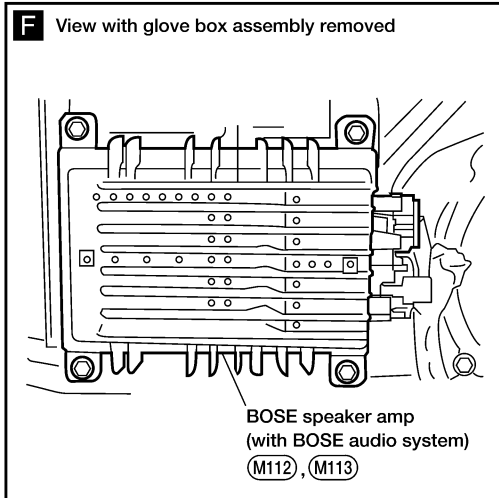

A
B
C
D
E
F
G
H
I
J
L
M

PG

WKIA5367E

HARNESS CONNECTOR

PPF:B4341

HARNESS CONNECTOR

EKS00FP8

Description

HARNESS CONNECTOR (TAB-LOCKING TYPE)

- The tab-locking type connectors help prevent accidental looseness or disconnection.
- The tab-locking type connectors are disconnected by pushing or lifting the locking tab(s). Refer to the illustration below.

Refer to the next page for description of the slide-locking type connector.

CAUTION:

Do not pull the harness or wires when disconnecting the connector.

[Example]

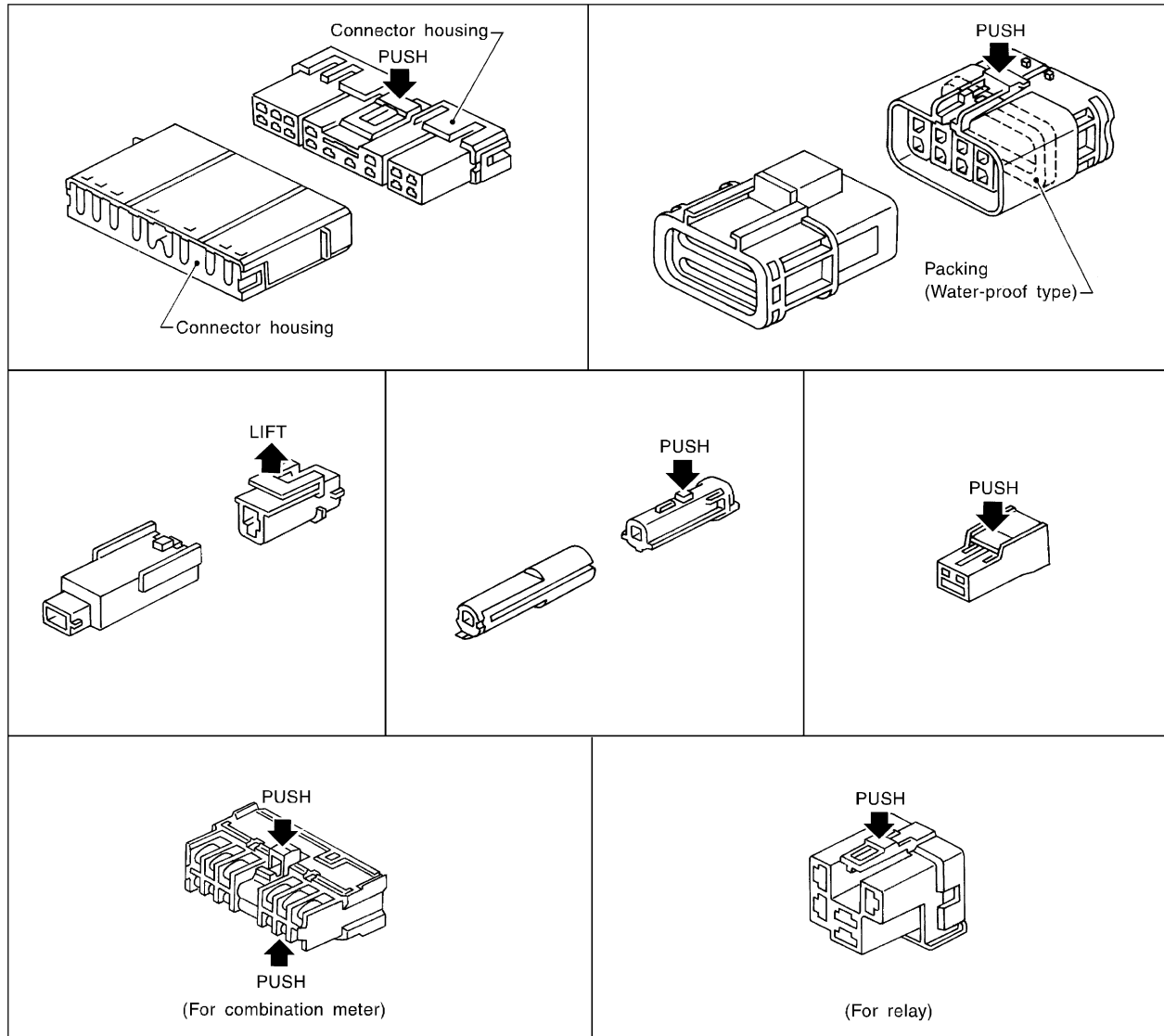

SEL769DA

HARNESS CONNECTOR

HARNESS CONNECTOR (SLIDE-LOCKING TYPE)

- A new style slide-locking type connector is used on certain systems and components, especially those related to OBD.
- The slide-locking type connectors help prevent incomplete locking and accidental looseness or disconnection.
- The slide-locking type connectors are disconnected by pushing or pulling the slider. Refer to the illustration below.

CAUTION:

- Do not pull the harness or wires when disconnecting the connector.
- Be careful not to damage the connector support bracket when disconnecting the connector.

[Example]

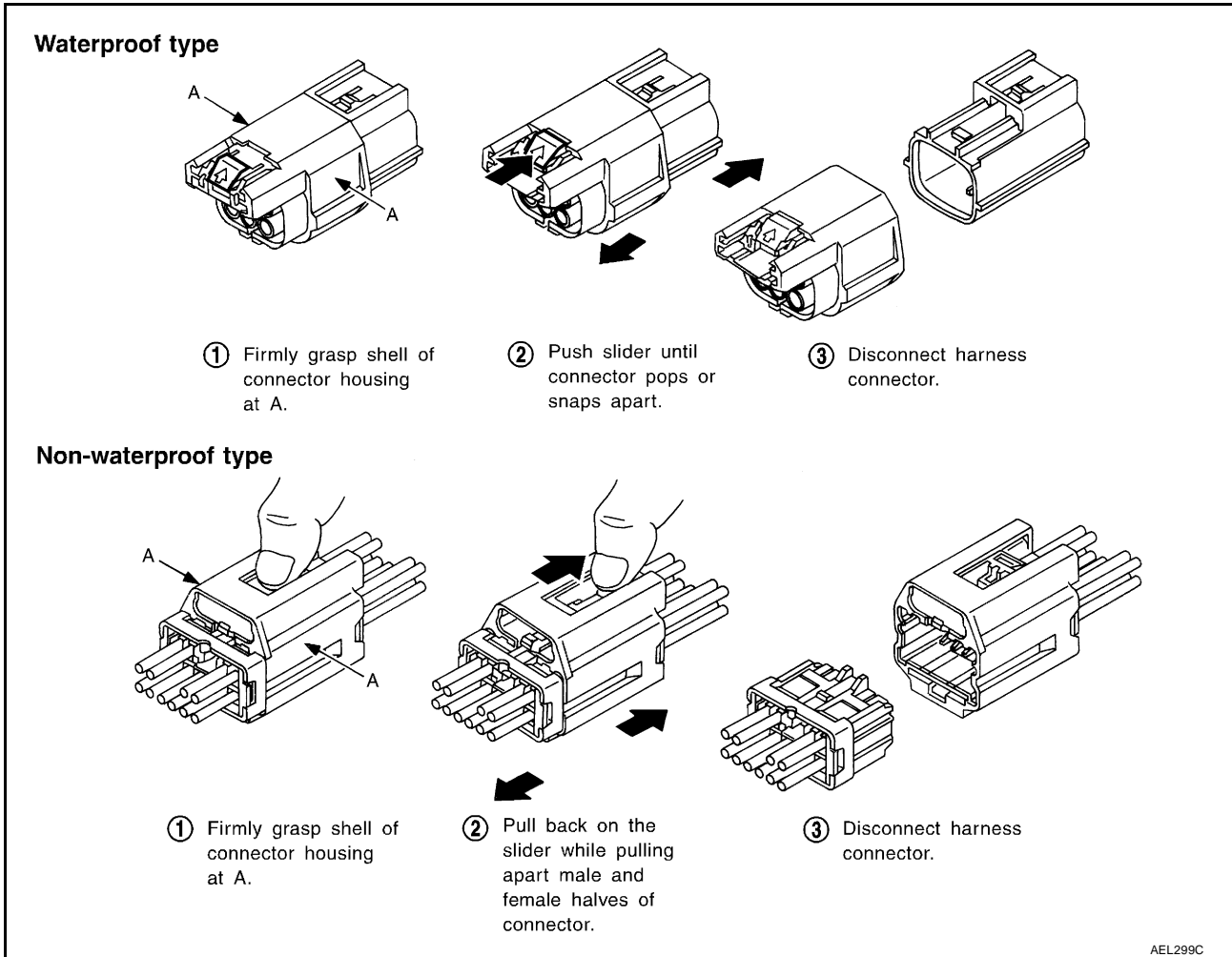

A
B
C
D
E
F
G
H
I
J
L
M

PG

HARNES CONNECTOR

HARNES CONNECTOR (LEVER LOCKING TYPE)

- Lever locking type harness connectors are used on certain control units and control modules such as ECM, ABS actuator and electric unit (control unit), etc.
- Lever locking type harness connectors are also used on super multiple junction (SMJ) connectors.
- Always confirm the lever is fully locked in place by moving the lever as far as it will go to ensure full connection.

CAUTION:

Always confirm the lever is fully released (loosened) before attempting to disconnect or connect these connectors to avoid damage to the connector housing or terminals.

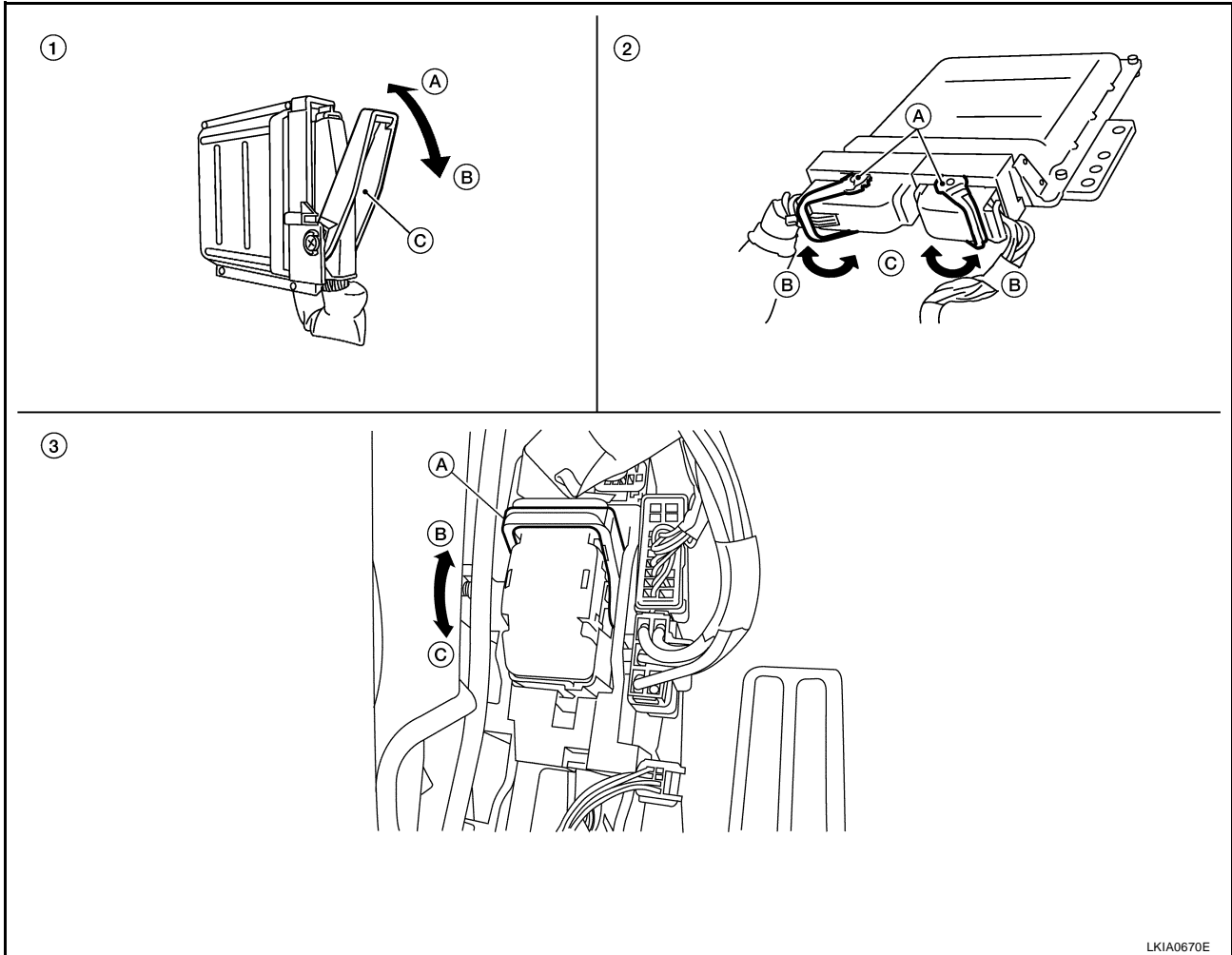

LKIA0670E

- | | | |
|-----------------------------------|----------------------------------|------------------|
| 1. Control unit with single lever | 2. Control unit with dual levers | 3. SMJ connector |
| A. Fasten | A. Levers | A. Lever |
| B. Loosen | B. Fasten | B. Fasten |
| C. Lever | C. Loosen | C. Loosen |

HARNESS CONNECTOR

HARNESS CONNECTOR (DIRECT-CONNECT SRS COMPONENT TYPE)

- SRS direct-connect type harness connectors are used on certain SRS components such as air bag modules and seat belt pre-tensioners.
- Always pull up to release black locking tab prior to removing connector from SRS component.
- Always push down to lock black locking tab after installing connector to SRS component. When locked, the black locking tab is level with the connector housing.

CAUTION:

- **Do not pull the harness or wires when removing connectors from SRS components.**

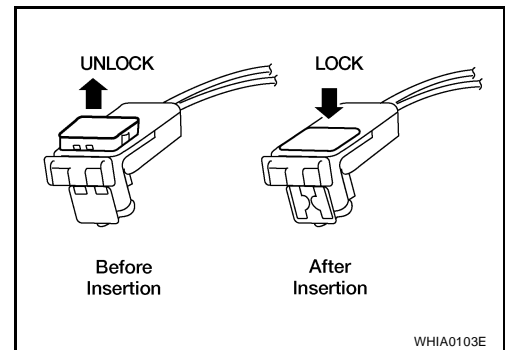

A

B

C

D

E

F

G

H

I

J

PG

L

M



ELECTRICAL UNITS

ELECTRICAL UNITS

PF2:23710

Terminal Arrangement

EKS00FP9

 : WITH VDC
 : WITHOUT VDC

BCM (BODY CONTROL MODULE)

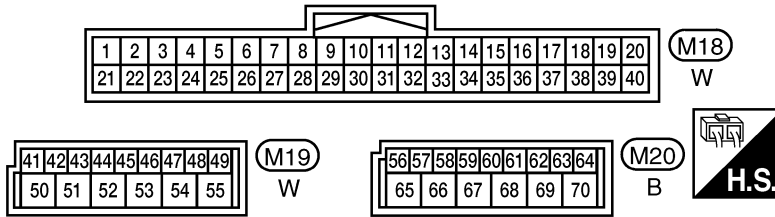

ABS ACTUATOR AND ELECTRIC UNIT (CONTROL UNIT)

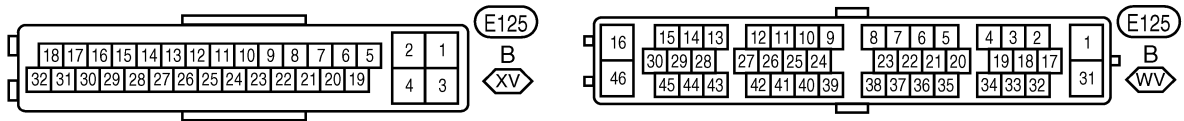

ECM

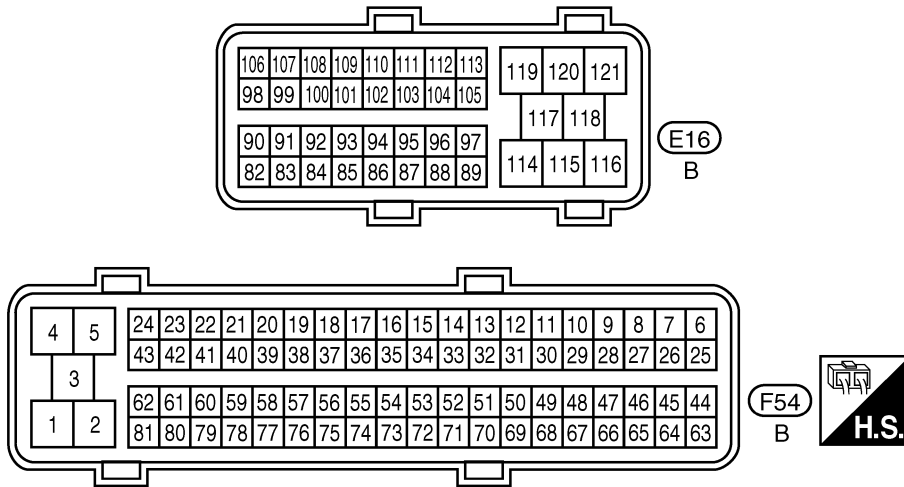

TCM (TRANSMISSION CONTROL MODULE)

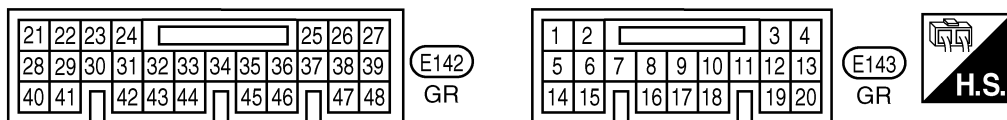

WKIA5412E

STANDARDIZED RELAY

PFP:25230

EKS00FPA

STANDARDIZED RELAY

Description

NORMAL OPEN, NORMAL CLOSED AND MIXED TYPE RELAYS

Relays can mainly be divided into three types: normal open, normal closed and mixed type relays.

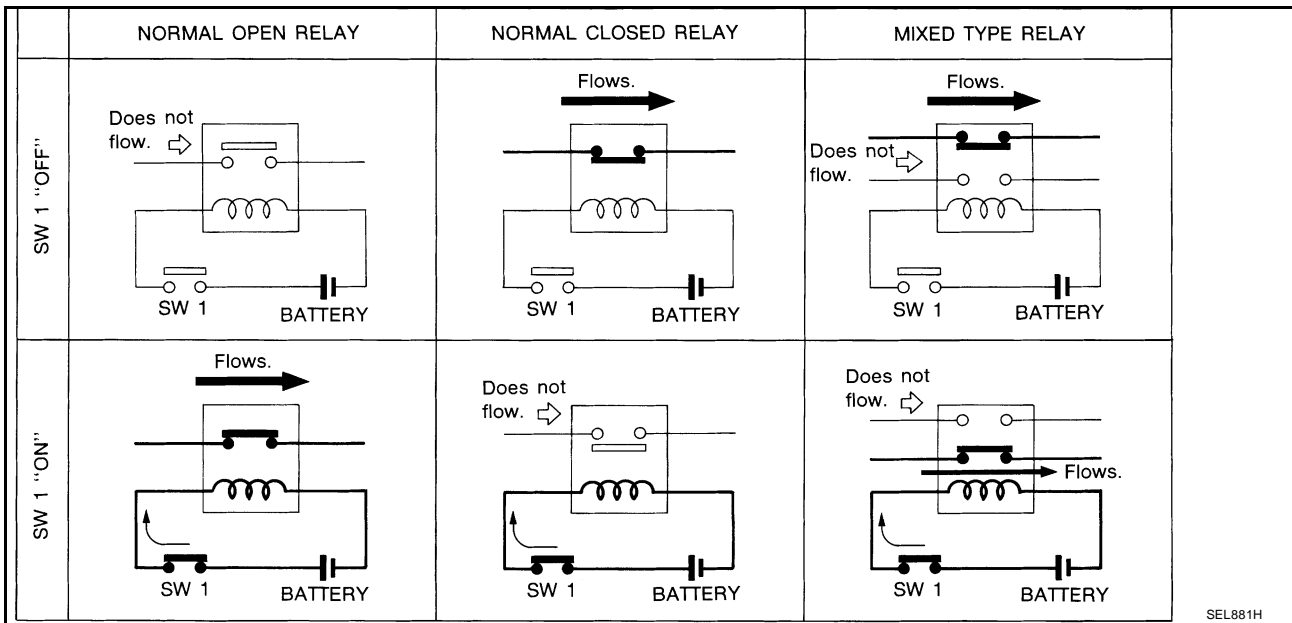

TYPE OF STANDARDIZED RELAYS

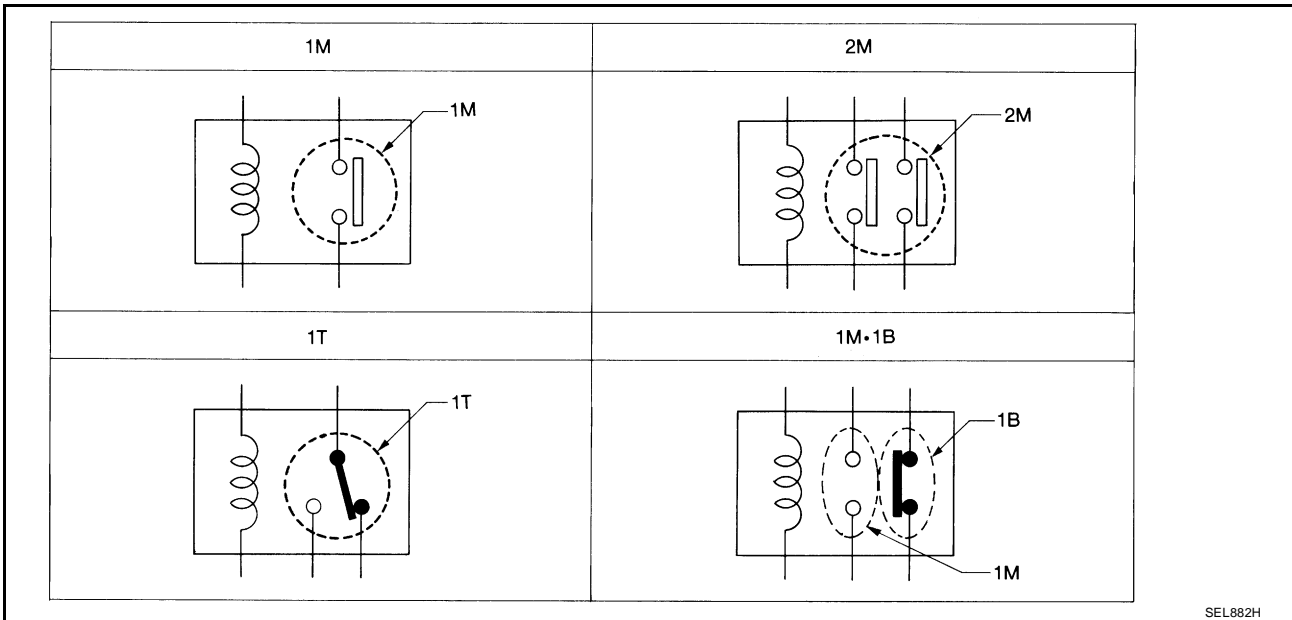

1M	1 Make	2M	2 Make
1T	1 Transfer	1M-1B	1 Make 1 Break

STANDARDIZED RELAY

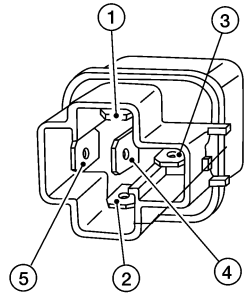
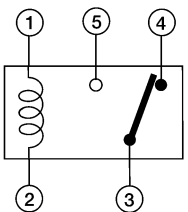
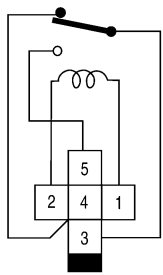
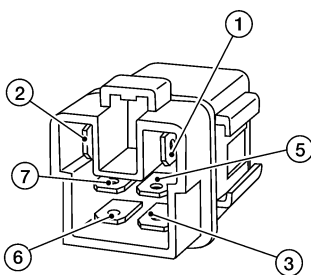
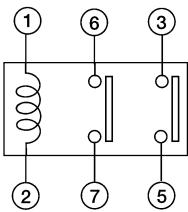
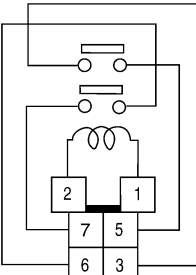
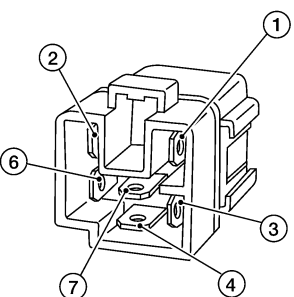
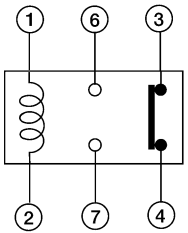
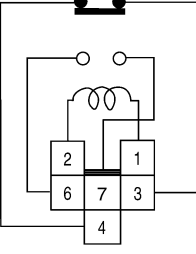
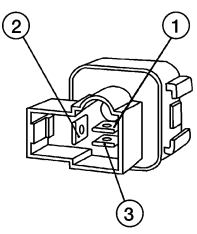
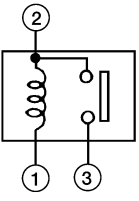
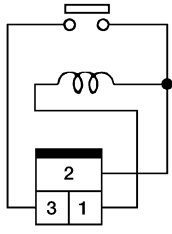
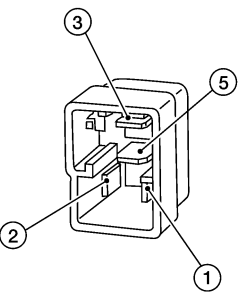
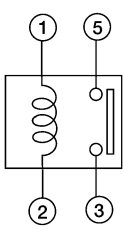
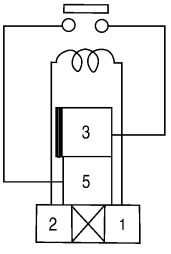
Type	Outer view	Circuit	Connector Symbol and connection	Case color
1T				BLACK
2M				BROWN
1M-1B				GRAY
1M				BLACK
				BLUE

The arrangement of terminal numbers on the actual relays may differ from those shown above.

WKIA0253E

SUPER MULTIPLE JUNCTION (SMJ)

SUPER MULTIPLE JUNCTION (SMJ)

PF:84341

Terminal Arrangement

EKS00FPB

FRONT SEAT HARNESS RH

(P102)

24A	23A	22A	21A	20A	19A	18A	17A	16A	15A	14A	13A	12A	11A	10A	9A	8A	7A	6A	5A	4A	3A	2A	1A
24B	23B	22B	21B	20B	19B	18B	17B	16B	15B	14B	13B	12B	11B	10B	9B	8B	7B	6B	5B	4B	3B	2B	1B



(B116)

24B	23B	22B	21B	20B	19B	18B	17B	16B	15B	14B	13B	12B	11B	10B	9B	8B	7B	6B	5B	4B	3B	2B	1B
24A	23A	22A	21A	20A	19A	18A	17A	16A	15A	14A	13A	12A	11A	10A	9A	8A	7A	6A	5A	4A	3A	2A	1A

BODY NO.2 HARNESS

A
B
C
D
E
F
G
H
I
J
L
M

PG

FUSE BLOCK-JUNCTION BOX (J/B)

PFP:24350

EKS00FPC

FUSE BLOCK-JUNCTION BOX (J/B)

Terminal Arrangement

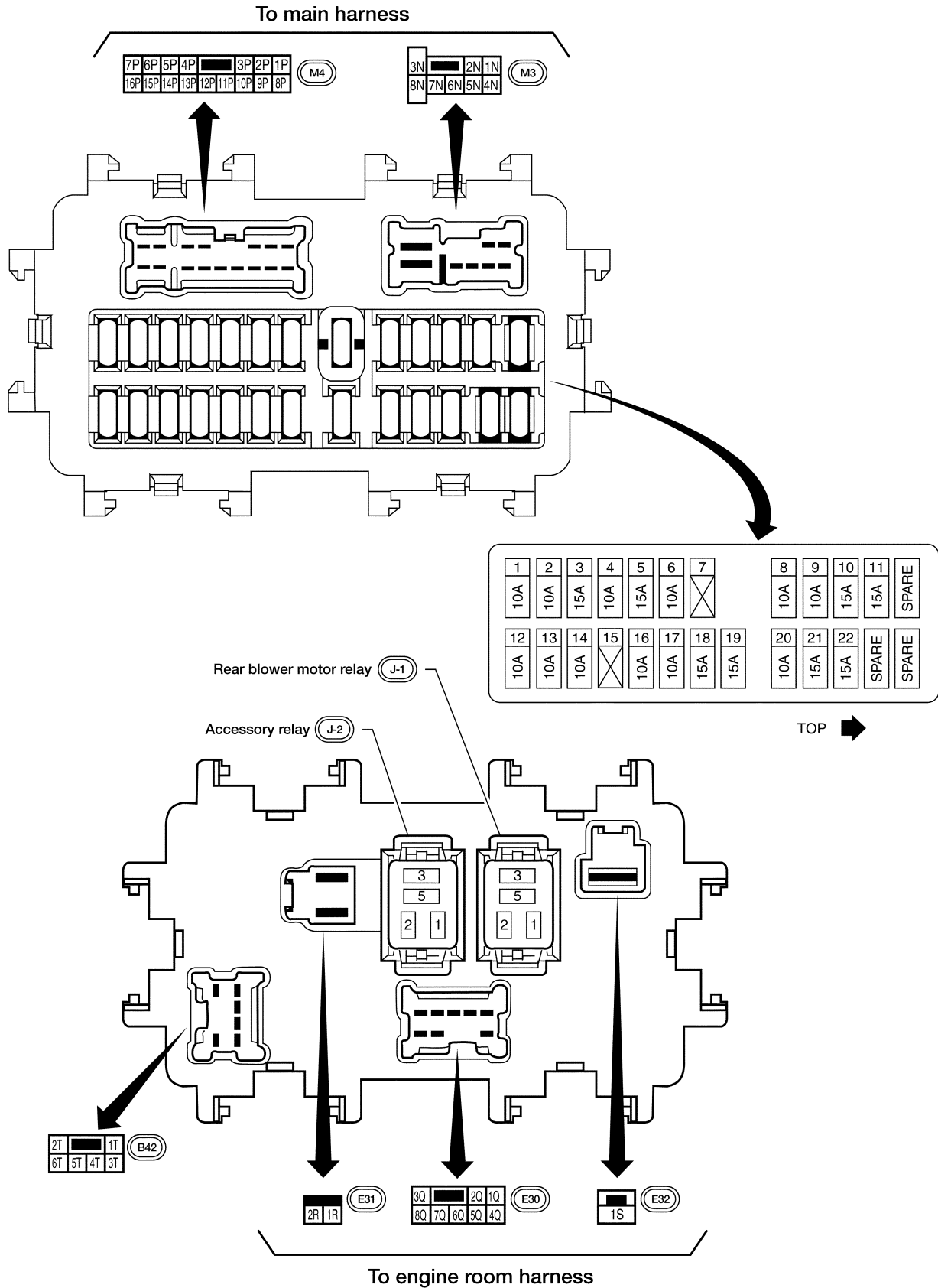

WKIA4511E

FUSE AND FUSIBLE LINK BOX

FUSE AND FUSIBLE LINK BOX

Terminal Arrangement

PFP:24381

EKS00FPD

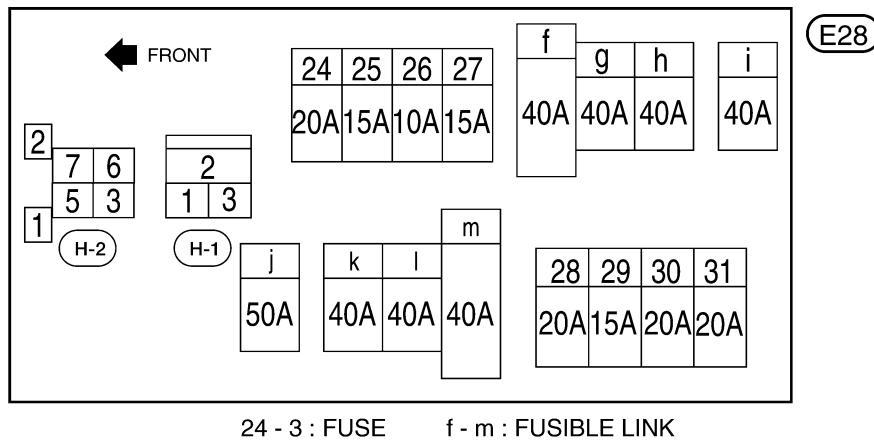

A
B
C
D
E
F
G
H
I
J
L
M

PG

WKIA5415E

FUSE AND FUSIBLE LINK BOX
