

A
EM
C
D
E
F
G
H
I
J
K
L
M

SECTION **EM**

ENGINE MECHANICAL

CONTENTS

<p>PRECAUTIONS 4</p> <ul style="list-style-type: none"> Precautions for Supplemental Restraint System (SRS) “AIR BAG” and “SEAT BELT PRE-TENSIONER” 4 Precautions for Drain Coolant 4 Precautions for Disconnecting Fuel Piping 4 Precautions for Removal and Disassembly 4 Precautions for Inspection, Repair and Replacement 4 Precautions for Assembly and Installation 4 Parts Requiring Angular Tightening 5 Precautions for Liquid Gasket 5 REMOVAL OF LIQUID GASKET SEALING 5 LIQUID GASKET APPLICATION PROCEDURE..... 5 <p>PREPARATION 7</p> <ul style="list-style-type: none"> Special Service Tools 7 Commercial Service Tools 9 <p>NOISE, VIBRATION, AND HARSHNESS (NVH)</p> <p>TROUBLESHOOTING11</p> <ul style="list-style-type: none"> NVH Troubleshooting — Engine Noise 11 Use the Chart Below to Help You Find the Cause of the Symptom. 12 <p>DRIVE BELTS 13</p> <ul style="list-style-type: none"> Checking Drive Belts 13 Tension Adjustment 13 GENERATOR AND AIR CONDITIONER COMPRESSOR BELT 14 POWER STEERING OIL PUMP BELT 15 Removal and Installation 15 REMOVAL 15 INSTALLATION 15 <p>AIR CLEANER AND AIR DUCT 16</p> <ul style="list-style-type: none"> Removal and Installation 16 REMOVAL 16 INSTALLATION 17 CHANGING AIR CLEANER FILTER 17 	<p>INTAKE MANIFOLD COLLECTOR 18</p> <ul style="list-style-type: none"> Removal and Installation 18 REMOVAL 19 INSPECTION AFTER REMOVAL 20 INSTALLATION 20 <p>EGR VOLUME CONTROL VALVE 22</p> <ul style="list-style-type: none"> Removal and Installation 22 REMOVAL 23 INSTALLATION 23 <p>INTAKE MANIFOLD 24</p> <ul style="list-style-type: none"> Removal and Installation 24 REMOVAL 24 INSPECTION AFTER REMOVAL 25 INSTALLATION 25 <p>EXHAUST MANIFOLD AND THREE WAY CATALYST 26</p> <ul style="list-style-type: none"> Removal and Installation 26 REMOVAL 27 INSPECTION AFTER REMOVAL 28 INSTALLATION 28 <p>OIL PAN AND OIL STRAINER 30</p> <ul style="list-style-type: none"> Removal and Installation 30 REMOVAL 30 INSPECTION AFTER REMOVAL 33 INSTALLATION 33 INSPECTION AFTER INSTALLATION 35 <p>IGNITION COIL 36</p> <ul style="list-style-type: none"> Removal and Installation 36 REMOVAL 36 INSTALLATION 37 <p>SPARK PLUG (PLATINUM-TIPPED TYPE) 38</p> <ul style="list-style-type: none"> Removal and Installation 38 REMOVAL 38 INSPECTION AFTER REMOVAL 39 INSTALLATION 39 <p>FUEL INJECTOR AND FUEL TUBE 40</p> <ul style="list-style-type: none"> Removal and Installation 40 REMOVAL 40 INSTALLATION 41 INSPECTION AFTER INSTALLATION 42
--	--

ROCKER COVER	43	ENGINE ASSEMBLY	112
Removal and Installation	43	Removal and Installation	112
REMOVAL	43	REMOVAL	113
INSTALLATION	44	INSTALLATION	116
FRONT TIMING CHAIN CASE	45	INSPECTION AFTER INSTALLATION	116
Removal and Installation	45	CYLINDER BLOCK	118
REMOVAL	46	Disassembly and Assembly	118
INSTALLATION	51	DISASSEMBLY	119
INSPECTION AFTER INSTALLATION	55	ASSEMBLY	122
TIMING CHAIN	56	How to Select Piston and Bearing	129
Removal and Installation	56	DESCRIPTION	129
REMOVAL	57	HOW TO SELECT A PISTON	129
INSPECTION AFTER INSTALLATION	77	HOW TO SELECT CONNECTING ROD BEAR-	
CAMSHAFT	78	INGS	130
Removal and Installation	78	HOW TO SELECT MAIN BEARINGS	131
REMOVAL	79	Inspection After Disassembly	134
INSPECTION AFTER REMOVAL	80	CRANKSHAFT END PLAY	134
INSTALLATION	82	CONNECTING ROD SIDE CLEARANCE	134
Inspection After Installation	87	PISTON AND PISTON PIN CLEARANCE	134
INSPECTION OF CAMSHAFT SPROCKET		PISTON RING SIDE CLEARANCE	135
(INT) OIL GROOVE	87	PISTON RING END GAP	135
Valve Clearance	87	CONNECTING ROD BEND AND TORSION ...	136
CHECKING	87	CONNECTING ROD BEARING HOUSING	
VALVE ADJUSTING	90	DIAMETER (BIG END)	136
INSPECTION AFTER INSTALLATION	91	CONNECTING ROD BUSHING OIL CLEAR-	
OIL SEAL	92	ANCE (SMALL END)	136
Removal and Installation of Valve Oil Seal	92	CYLINDER BLOCK DISTORTION	137
REMOVAL	92	INNER DIAMETER OF MAIN BEARING HOUS-	
INSTALLATION	92	ING	138
Removal and Installation of Front Oil Seal	92	PISTON-TO-CYLINDER BORE CLEARANCE .	138
REMOVAL	92	OUTER DIAMETER OF CRANKSHAFT JOUR-	
INSTALLATION	93	NAL	140
Removal and Installation of Rear Oil Seal	95	OUTER DIAMETER OF CRANKSHAFT PIN ...	140
REMOVAL	95	OUT-OF-ROUND AND TAPER OF CRANK-	
INSTALLATION	95	SHAFT	140
CYLINDER HEAD	96	CRANKSHAFT RUNOUT	140
On-Vehicle Service	96	OIL CLEARANCE OF CONNECTING ROD	
CHECKING COMPRESSION PRESSURE	96	BEARING	140
Removal and Installation	97	OIL CLEARANCE OF MAIN BEARING	141
REMOVAL	97	CRUSH HEIGHT OF MAIN BEARING	142
INSPECTION AFTER REMOVAL	99	CRUSH HEIGHT OF CONNECTING ROD	
INSTALLATION	99	BEARING	142
Disassembly and Assembly	105	OUTER DIAMETER OF MAIN BEARING CAP	
DISASSEMBLY	106	BOLTS	142
Inspection After Disassembly	107	OUTER DIAMETER OF CONNECTING ROD	
CYLINDER HEAD DISTORTION	107	BOLTS	143
VALVE DIMENSIONS	107	DRIVE PLATE	143
VALVE GUIDE CLEARANCE	107	OIL JET	143
VALVE GUIDE REPLACEMENT	108	OIL JET RELIEF VALVE	143
VALVE SEAT CONTACT	109	SERVICE DATA AND SPECIFICATIONS (SDS) ...	144
VALVE SEAT REPLACEMENT	109	Standard and Limit	144
VALVE SPRING SQUARENESS	110	GENERAL SPECIFICATIONS	144
VALVE SPRING DIMENSIONS AND VALVE		DRIVE BELT	145
SPRING PRESSURE LOAD	110	INTAKE MANIFOLD COLLECTOR, INTAKE	
ASSEMBLY	110		

MANIFOLD AND EXHAUST MANIFOLD	145
SPARK PLUG	146
CYLINDER HEAD	146
VALVE	146
CAMSHAFT AND CAMSHAFT BEARING	150
CYLINDER BLOCK	150
PISTON, PISTON RING AND PISTON PIN	151
CONNECTING ROD	152
CRANKSHAFT	153
AVAILABLE MAIN BEARING	154
CONNECTING ROD BEARING	154
BEARING CLEARANCE	155

A

EM

C

D

E

F

G

H

I

J

K

L

M

PRECAUTIONS

PRECAUTIONS

PF0:00001

Precautions for Supplemental Restraint System (SRS) “AIR BAG” and “SEAT BELT PRE-TENSIONER”

EBS00U6C

The Supplemental Restraint System such as “AIR BAG” and “SEAT BELT PRE-TENSIONER”, used along with a front seat belt, helps to reduce the risk or severity of injury to the driver and front passenger for certain types of collision. This system includes seat belt switch inputs and dual stage front air bag modules. The SRS system uses the seat belt switches to determine the front air bag deployment, and may only deploy one front air bag, depending on the severity of a collision and whether the front occupants are belted or unbelted. Information necessary to service the system safely is included in the SRS and SB section of this Service Manual.

WARNING:

- To avoid rendering the SRS inoperative, which could increase the risk of personal injury or death in the event of a collision which would result in air bag inflation, all maintenance must be performed by an authorized NISSAN/INFINITI dealer.
- Improper maintenance, including incorrect removal and installation of the SRS, can lead to personal injury caused by unintentional activation of the system. For removal of Spiral Cable and Air Bag Module, see the SRS section.
- Do not use electrical test equipment on any circuit related to the SRS unless instructed to in this Service Manual. SRS wiring harnesses can be identified by yellow and/or orange harnesses or harness connectors.

Precautions for Drain Coolant

EBS00PR4

- Drain coolant when engine is cooled.

Precautions for Disconnecting Fuel Piping

EBS00PR5

- Before starting work, make sure no fire or spark producing items are in the work area.
- Release fuel pressure before disassembly.
- After disconnecting pipes, plug openings to stop fuel leakage.

Precautions for Removal and Disassembly

EBS00PR6

- When instructed to use special service tools, use the specified tools. Always be careful to work safely, avoid forceful or uninstructed operations.
- Exercise maximum care to avoid damage to mating or sliding surfaces.
- Cover openings of engine system with tape or the equivalent, if necessary, to seal out foreign materials.
- Mark and arrange disassembly parts in an organized way for easy troubleshooting and assembly.
- When loosening nuts and bolts, as a basic rule, start with the one furthest outside, then the one diagonally opposite, and so on. If the order of loosening is specified, do exactly as specified. Power tools may be used where noted in the step.

Precautions for Inspection, Repair and Replacement

EBS00PR7

- Before repairing or replacing, thoroughly inspect parts. Inspect new replacement parts in the same way, and replace if necessary.

Precautions for Assembly and Installation

EBS00PR8

- Use torque wrench to tighten bolts or nuts to specification.
- When tightening nuts and bolts, as a basic rule, equally tighten in several different steps starting with the ones in center, then ones on inside and outside diagonally in this order. If the order of tightening is specified, do exactly as specified.
- Replace with new gasket, packing, oil seal or O-ring.
- Thoroughly wash, clean, and air-blow each part. Carefully check oil or coolant passages for any restriction and blockage.
- Avoid damaging sliding or mating surfaces. Completely remove foreign materials such as cloth lint or dust. Before assembly, oil sliding surfaces well.
- Release air within route after draining coolant.

PRECAUTIONS

- Before starting engine, apply fuel pressure to fuel lines with turning ignition switch ON (with engine stopped). Then make sure that there are no leaks at fuel line connections.
- After repairing, start engine and increase engine speed to check coolant, fuel, oil, and exhaust systems for leakage.

Parts Requiring Angular Tightening

EBS00PR9

- Use an angle wrench for the final tightening of the following engine parts:
 - Cylinder head bolts
 - Main bearing cap bolts
 - Connecting rod cap nuts
 - Crankshaft pulley bolt
- Do not use a torque value for final tightening.
- The torque value for these parts are for a preliminary step.
- Ensure thread and seat surfaces are clean and coated with engine oil.

Precautions for Liquid Gasket

EBS00PRA

REMOVAL OF LIQUID GASKET SEALING

- After removing the bolts and nuts, separate the mating surface using Tool and remove the liquid gasket sealing.

Tool number : KV10111100 (J-37228)

CAUTION:

Be careful not to damage the mating surfaces.

- In areas where the Tool is difficult to use, use a plastic hammer to lightly tap the Tool (1) where the Silicone RTV Sealant is applied. Use a plastic hammer to slide the Tool (2) by tapping on the side.

CAUTION:

If for some unavoidable reason a tool such as a flat-bladed screwdriver is used, be careful not to damage the mating surfaces.

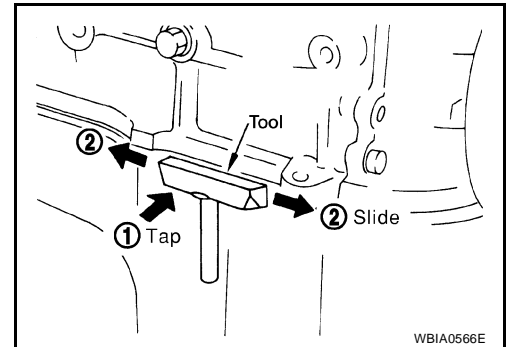

LIQUID GASKET APPLICATION PROCEDURE

1. Using a scraper, remove the old Silicone RTV Sealant adhering to the gasket application surface and the mating surface.
 - Remove the sealant completely from the groove of the gasket application surface, bolts, and bolt holes.
2. Thoroughly clean the gasket application surface and the mating surface and remove adhering moisture, grease and foreign materials.
3. Attach the sealant tube to the tube presser.
 - Use Genuine Silicone RTV Sealant or equivalent. Refer to [GI-46, "RECOMMENDED CHEMICAL PRODUCTS AND SEALANTS"](#).
4. Apply the sealant using Tool without breaks to the specified location.

Tool number : WS39930000 (—)

- If there is a groove for the sealant application, apply the sealant to the groove.
- As for the bolt holes, normally apply the sealant inside the holes. If specified, it should be applied outside the holes. Make sure to read the text of this manual.
- Within five minutes of the sealant application, install the mating component.
- If the sealant protrudes, wipe it off immediately.

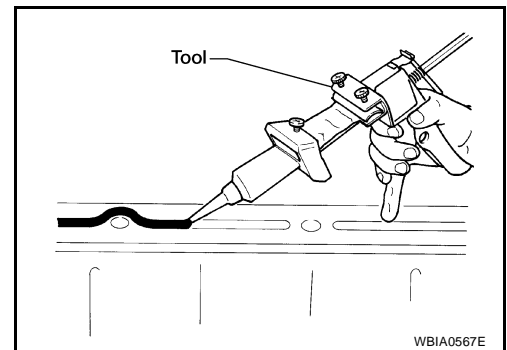
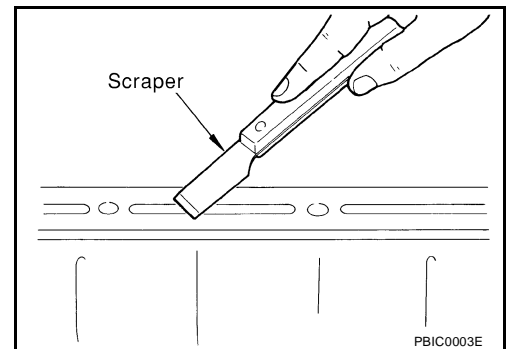

PRECAUTIONS

- Do not retighten after the installation.
- After 30 minutes or more have passed from the installation, fill the engine with the specified oil and coolant. Refer to [MA-9](#), "[RECOMMENDED FLUIDS AND LUBRICANTS](#)".

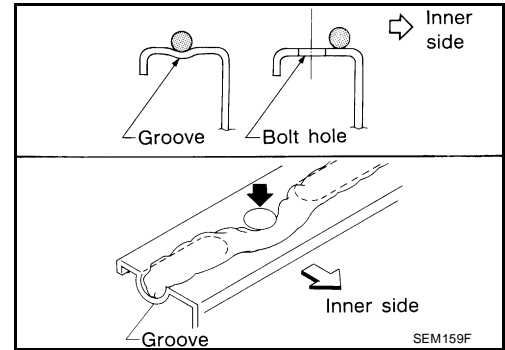

CAUTION:
Follow all specific instructions in this manual.

PREPARATION

PF0:00002

PREPARATION

Special Service Tools



EBS00PRB

The actual shapes of Kent-Moore tools may differ from those of special service tools illustrated here.

Tool number (Kent-Moore No.) Tool name	Description
— (J-47242) Engine support table	Engine and transmission assembly removal
KV10116200 (J-26336-B) Valve spring compressor 1 KV10115900 (J-26336-20) Attachment 2 KV1019230 (—)	Disassembling valve mechanism Part (1) is a component of KV10116200 (J-26336-B), but Part (2) is not.
KV10107902 (J-38959) Valve oil seal puller	Removing valve oil seal
(J-39386) Valve oil seal drift	Installing valve oil seal
KV991J0120 (J-47128) Seal installer	Installing rear main seal
EM03470000 (J-8037) Piston ring compressor	Installing piston assembly into cylinder bore
ST16610001 (J-23907) Pilot bushing puller	Removing crankshaft pilot bushing

A
EM
C
D
E
F
G
H
I
J
K
L
M

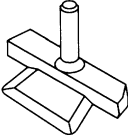
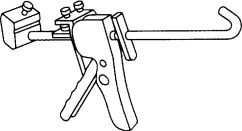
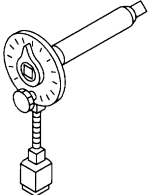
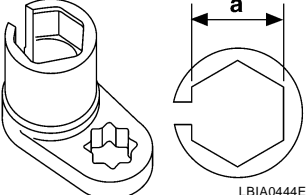
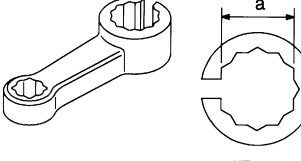
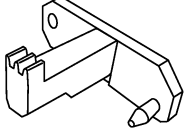
PREPARATION

Tool number (Kent-Moore No.) Tool name	Description
KV10111100 (J-37228) Seal cutter  NT046	Removing steel oil pan and rear timing chain case
WS39930000 (—) Tube presser  NT052	Pressing the tube of liquid gasket
KV10112100 (BT-8653-A) Angle wrench  NT014	Tightening bolts for bearing cap, cylinder head, etc.
KV991J0050 (J-44626) Air fuel sensor Socket  LBIA0444E	Loosening or tightening air fuel ratio A/F sensor a: 22 mm (0.87 in) Unit: mm (in)
KV10114400 (J-38365) Heated oxygen sensor wrench  NT636	Loosening or tightening rear heated oxygen sensor a: 22 (0.87) Unit: mm (in)
KV10117700 (J-44716) Ring gear stopper  NT822	Removing and installing crankshaft pulley
— (J-45488) Quick connector release  PBIC0198E	Disconnecting fuel tube quick disconnect connectors in engine compartment

PREPARATION

Commercial Service Tools

EBS00PRC

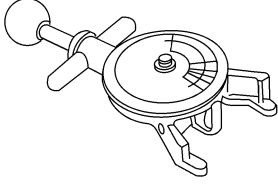
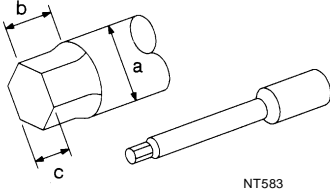
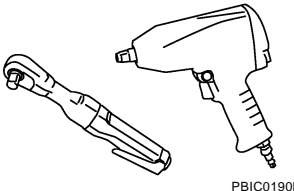
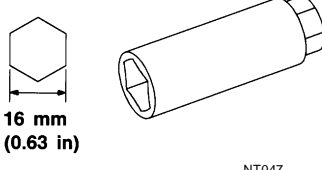
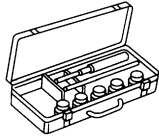
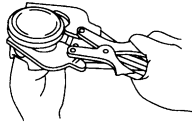
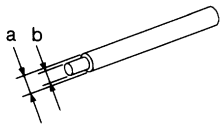
(Kent-Moore No.) Tool name	Description	A
(BT-3373-F) Belt tension gauge  <p style="text-align: right; margin-right: 50px;">AMA126</p>	Checking drive belt tension	EM
(J-24239-01) Cylinder head bolt wrench  <p style="text-align: right; margin-right: 50px;">NT583</p>	Loosening and tightening cylinder head bolt a: 13 (0.51) dia. b: 12 (0.47) c: 10 (0.39) Unit: mm (in)	C
Power tool  <p style="text-align: right; margin-right: 50px;">PBIC0190E</p>	Loosening bolts and nuts	D
Spark plug wrench  <p style="text-align: right; margin-right: 50px;">NT047</p>	Removing and installing spark plug	E
Valve seat cutter set  <p style="text-align: right; margin-right: 50px;">NT048</p>	Finishing valve seat dimensions	F
Piston ring expander  <p style="text-align: right; margin-right: 50px;">NT030</p>	Removing and installing piston ring	G
Valve guide drift  <p style="text-align: right; margin-right: 50px;">NT015</p>	Removing and installing valve guide Intake & Exhaust: a = 9.5 (0.374) dia. b = 5.5 (0.217) Unit: mm (in)	H

PREPARATION

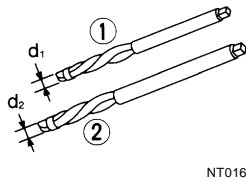
(Kent-Moore No.) Tool name	Description
Valve guide reamer 	Reaming valve guide 1 or hole for oversize valve guide 2 Intake & Exhaust: d1 = 6.0 (0.236) dia. d2 = 10.175 - 10.196 (0.4006 - 0.4014) Unit: mm (in)
(J-43897-18) (J-43897-12) Oxygen sensor thread cleaner	Reconditioning the exhaust system threads before installing a new heated oxygen sensor (Use with anti-seize lubricant shown below.) a = (J-43897-18) 18 mm (0.71 in) for zirconia heated oxygen sensor b = (J-43897-12) 12 mm (0.47 in) for titania heated oxygen sensor
Anti-seize lubricant (Permatex 133AR or equivalent meeting MIL specification MIL-A-907)	Lubricating heated oxygen sensor thread cleaning tool when reconditioning exhaust system threads

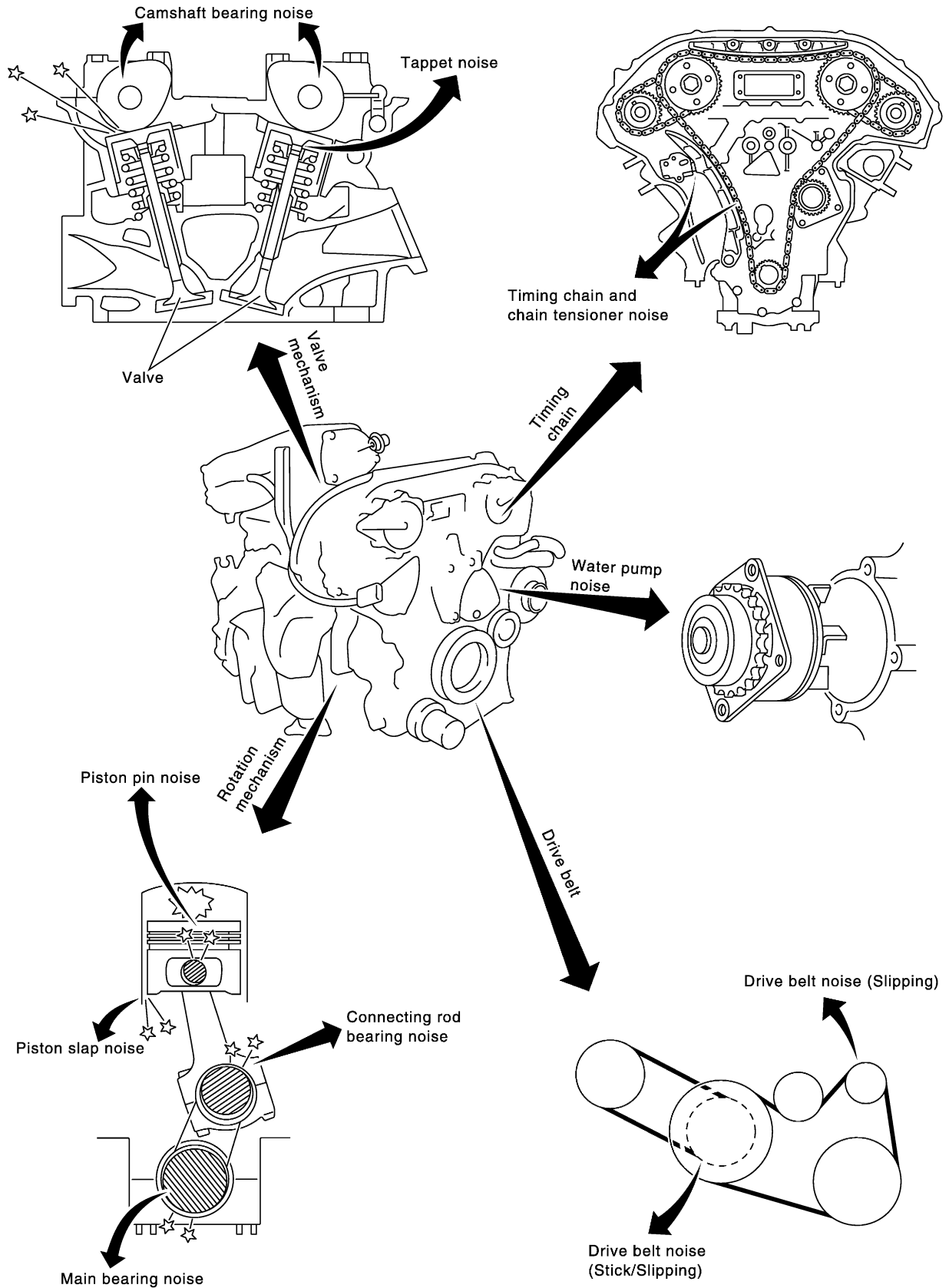

NOISE, VIBRATION, AND HARSHNESS (NVH) TROUBLESHOOTING

Use the Chart Below to Help You Find the Cause of the Symptom.

EBS00PRE

1. Locate the area where noise occurs.
2. Confirm the type of noise.
3. Specify the operating condition of engine.
4. Check specified noise source. Repair or replace the identified part as necessary.

Location of noise	Type of noise	Operating condition of engine						Source of noise	Check item	Reference page
		Before warm-up	After warm-up	When starting	When idling	When racing	While driving			
Top of engine Rocker cover Cylinder head	Ticking or clicking	C	A	—	A	B	—	Tappet noise	Valve clearance	EM-87
	Rattle	C	A	—	A	B	C	Camshaft bearing noise	Camshaft journal clearance Camshaft runout	EM-78
Crankshaft pulley Cylinder block (Side of engine) Oil pan	Slap or knock	—	A	—	B	B	—	Piston pin noise	Piston and piston pin clearance Connecting rod bushing clearance	EM-96
	Slap or rap	A	—	—	B	B	A	Piston slap noise	Piston-to-bore clearance Piston ring side clearance Piston ring end gap Connecting rod bend and torsion	EM-118
	Knock	A	B	C	B	B	B	Connecting rod bearing noise	Connecting rod bushing clearance (Small end) Connecting rod bearing clearance (Big end)	EM-118
	Knock	A	B	—	A	B	C	Main bearing noise	Main bearing oil clearance Crankshaft runout	EM-118
Front of engine Timing chain cover	Tapping or ticking	A	A	—	B	B	B	Timing chain and chain tensioner noise	Timing chain cracks and wear Timing chain tensioner operation	EM-56
Front of engine	Squeaking or fizzing	A	B	—	B	—	C	Drive belts (Sticking or slipping)	Drive belts deflection	EM-13
	Creaking	A	B	A	B	A	B	Drive belts (Slipping)	Idler pulley bearing operation	
	Squall Creak	A	B	—	B	A	B	Water pump noise	Water pump operation	CO-18

A: Closely related B: Related C: Sometimes related —: Not related

DRIVE BELTS

FPF:02117

EBS00PRF

DRIVE BELTS

Checking Drive Belts

WARNING:

Be sure to perform when the engine is not running.

1. Inspect belt for cracks, fraying, wear or oil adhesion. If necessary, replace with a new one.
2. Inspect drive belt deflections by applying 98 N (10 kg-f, 22 lb-f) on the belt midway between pulleys as shown.
3. Measure the belt tension using Tool at the locations as shown.

Tool number : BT-3373-F

NOTE:

- Inspect drive belt deflection or tension when engine is cold.
- Adjust if belt deflections exceed the limit or if belt tension is not within specifications.

CAUTION:

- When checking belt deflection or tension immediately after installation, first adjust it to the specification value. Then, after turning the crankshaft two turns or more, readjust to the specified value to avoid variation in deflection between pulleys.
- Tighten idler pulley lock nut by hand and measure deflection or tension without looseness.

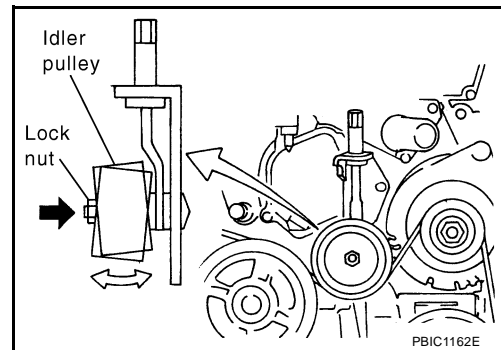
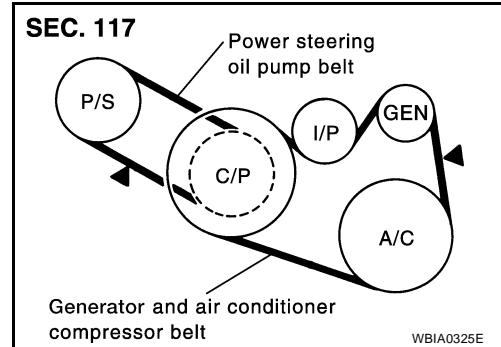

Belt Deflection and Tension

	Deflection adjustment		Unit: mm (in)	Tension adjustment*		Unit: N (kg-f, lb-f)
	Used belt			Used belt		
	Limit	After adjustment	New belt	Limit	After adjustment	New belt
Generator and air conditioner compressor	7 (0.28)	4.2 - 4.6 (0.17 - 0.18)	3.7 - 4.1 (0.15 - 0.16)	294 (30, 66)	730 - 818 (74.5 - 83.5, 164 - 184)	838 - 926 (85.5 - 94.5, 188 - 208)
Power steering oil pump	11 (0.43)	7.3 - 8.0 (0.29 - 0.30)	6.5 - 7.2 (0.26 - 0.28)	196 (20, 44)	495 - 583 (50.5 - 59.5, 111 - 131)	603 - 691 (61.5 - 70.5, 135.6 - 155.4)
Applied pushing force	98 N (10 kg-f, 22 lb-f)			—		

*: If belt tension gauge cannot be installed at check points as shown, check drive belt tension at different location on the belt.

Tension Adjustment

EBS00PRG

Belt description	Belt tightening method for adjustment
Power steering oil pump belt	Adjusting bolt on power steering oil pump
Generator and air conditioner compressor belt	Adjusting bolt on idler pulley bracket

CAUTION:

- When belt is replaced with a new one, adjust it to value for "New belt" to accommodate for insufficient adaptability with pulley grooves.

DRIVE BELTS

- When deflection or tension of belt being used exceeds "Used belt limit" adjust it to value for "After adjustment" of "Used belt".
- When checking belt deflection or tension immediately after installation, first adjust it to the specification value. Then, after turning the crankshaft two turns or more, readjust to the specified value to avoid variation in deflection between pulleys.
- When installing belt, make sure that it is correctly engaged with pulley groove.
- Keep oil and water away from belt.
- Do not twist or bend belt excessively.

GENERATOR AND AIR CONDITIONER COMPRESSOR BELT

1. Remove engine undercover.
2. Loosen idler pulley lock nut "A" and adjust the belt by turning adjusting bolt "B".
 - For specified belt deflection and tension, refer to [EM-13. "Checking Drive Belts"](#) .
3. Tighten lock nut "A".

Lock nut "A" : 34.8 N·m (3.5 kg-m, 26 ft-lb)

4. Tighten adjusting bolt "B".

Adjusting bolt "B" : 5.4 N·m (0.55 kg-m, 48 in-lb)

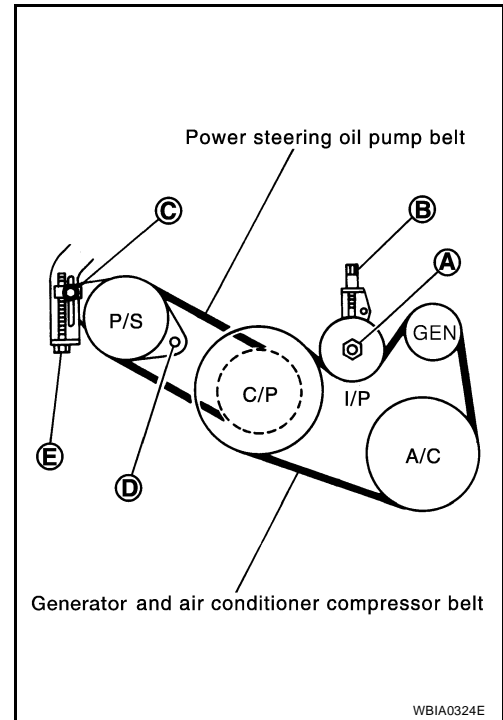

DRIVE BELTS

POWER STEERING OIL PUMP BELT

1. Remove engine undercover.
2. Loosen adjusting bolt "C".
3. Loosen power steering oil pump bolt "D".

NOTE:

Bolt head "D" is at the engine rear side.

4. Adjust the belt by turning the adjusting bolt "E".
 - For specified belt deflection and tension, refer to [EM-13, "Checking Drive Belts"](#).

NOTE:

Adjusting bolt "E" is loosened with counterclockwise rotation.

5. Tighten adjusting bolt "C".

Adjusting bolt "C" : 28.0 N·m (2.9 kg-m, 21 ft-lb)

6. Tighten power steering oil pump bolt "D".

Power steering pump bolt "D" : 43.2 N·m (4.4 kg-m, 32 ft-lb)

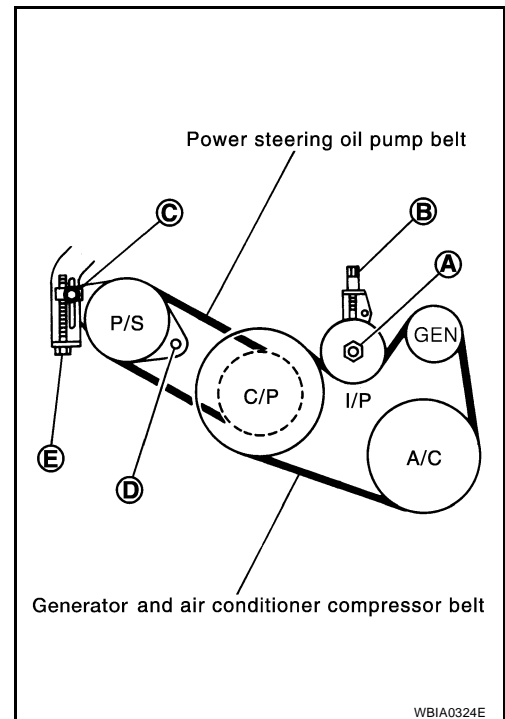

Removal and Installation

REMOVAL

1. Remove engine undercover.
2. Fully loosen each belt. Refer to [EM-13, "Tension Adjustment"](#). Remove generator and air conditioner compressor belt and then power steering oil pump belt.

CAUTION:

Grease is applied to idler pulley adjusting bolt. Be careful to keep grease away from the belts.

INSTALLATION

Installation is in the reverse order of removal.

CAUTION:

- Make sure belts are correctly engaged with the pulley groove.
- Clean off any oil and coolant on belts and each pulley groove.
- Adjust belt tension. Refer to [EM-13, "Tension Adjustment"](#).

AIR CLEANER AND AIR DUCT

AIR CLEANER AND AIR DUCT

PF16500

Removal and Installation

EBS00PRI

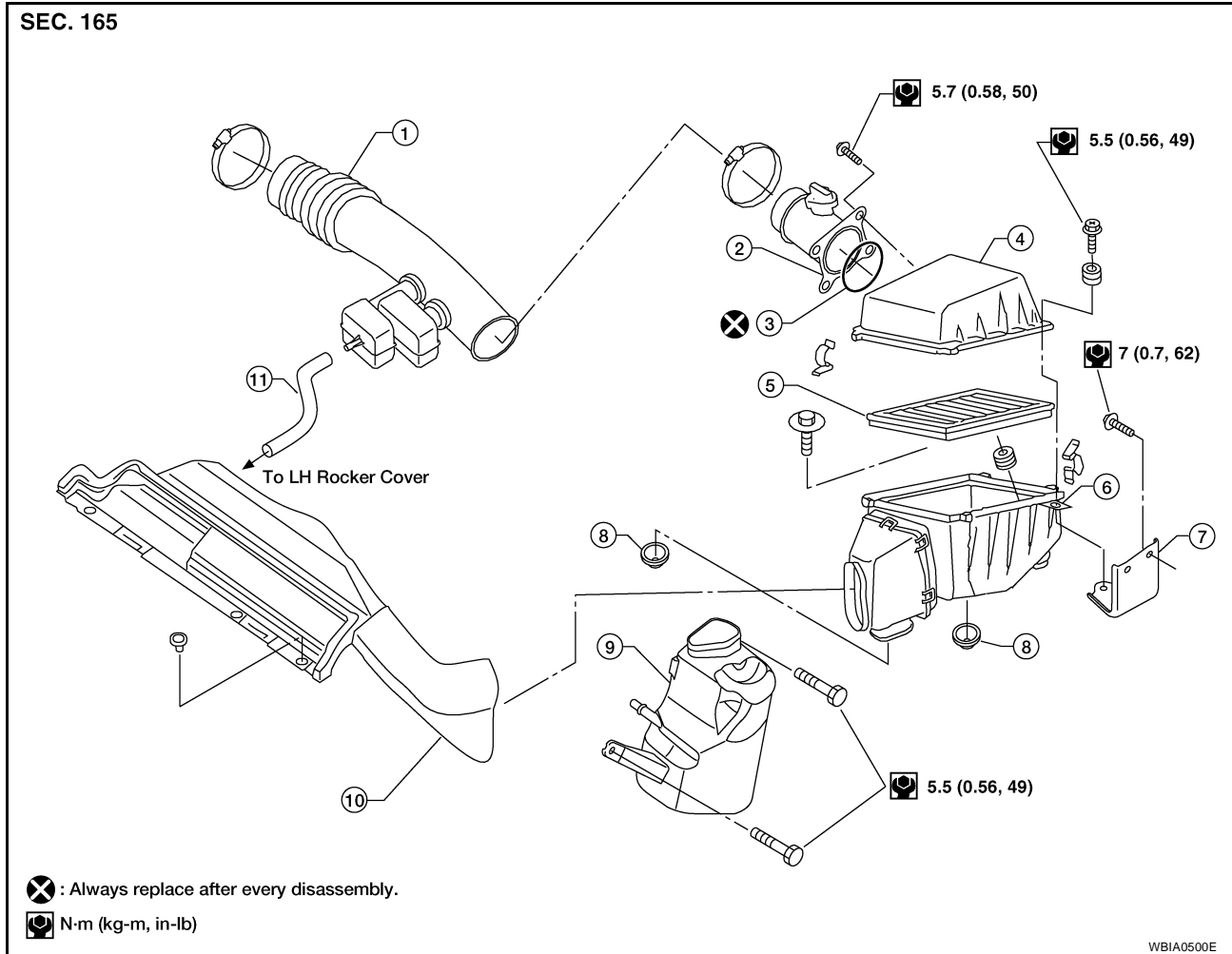

- | | | |
|---|-------------------------|-----------------------------|
| 1. Air cleaner to electric throttle control actuator tube | 2. Mass air flow sensor | 3. O-ring |
| 4. Air cleaner case (upper) | 5. Air cleaner filter | 6. Air cleaner case (lower) |
| 7. Air cleaner case bracket | 8. Grommet | 9. Resonator (in fender) |
| 10. Fresh air duct | 11. PCV hose | |

REMOVAL

1. Remove the fresh air duct.
2. Disconnect the harness connector from the mass air flow sensor.
3. Disconnect the tube clamp at the electric throttle control actuator.
4. Disconnect the PCV hose.
5. Remove air cleaner to electric throttle control actuator tube, air cleaner case (upper) with the mass air flow sensor attached.
6. Remove mass air flow sensor from air cleaner case (upper), as necessary.

CAUTION:

Handle mass air flow sensor with care.

- Do not shock it.
- Do not disassemble it.
- Do not touch ithe sensor.

7. Remove the air cleaner case (lower).
8. Remove resonator in the fender, lifting left fender protector, as necessary.

AIR CLEANER AND AIR DUCT

INSTALLATION

Installation is in the reverse order of removal.

CHANGING AIR CLEANER FILTER

NOTE:

The viscous paper type filter does not need cleaning between replacement intervals. Refer to [MA-6, "PERIODIC MAINTENANCE"](#).

1. Disconnect the tube clamp at the air cleaner to electric throttle control actuator tube at the mass air flow sensor.
2. Separate the mass air flow sensor from the air cleaner to electric throttle control actuator tube.
3. Unhook the air cleaner case side clips and remove the air cleaner case (upper).
4. Remove the air cleaner filter.
5. Install a new air cleaner filter.
6. Install the remaining components in the reverse order of removal.

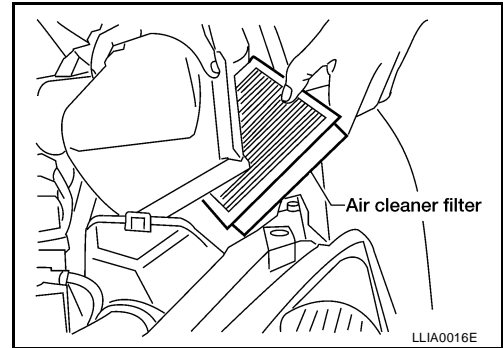

A

EM

C

D

E

F

G

H

I

J

K

L

M

INTAKE MANIFOLD COLLECTOR

INTAKE MANIFOLD COLLECTOR

PFP:14010

Removal and Installation

EBS00PRJ

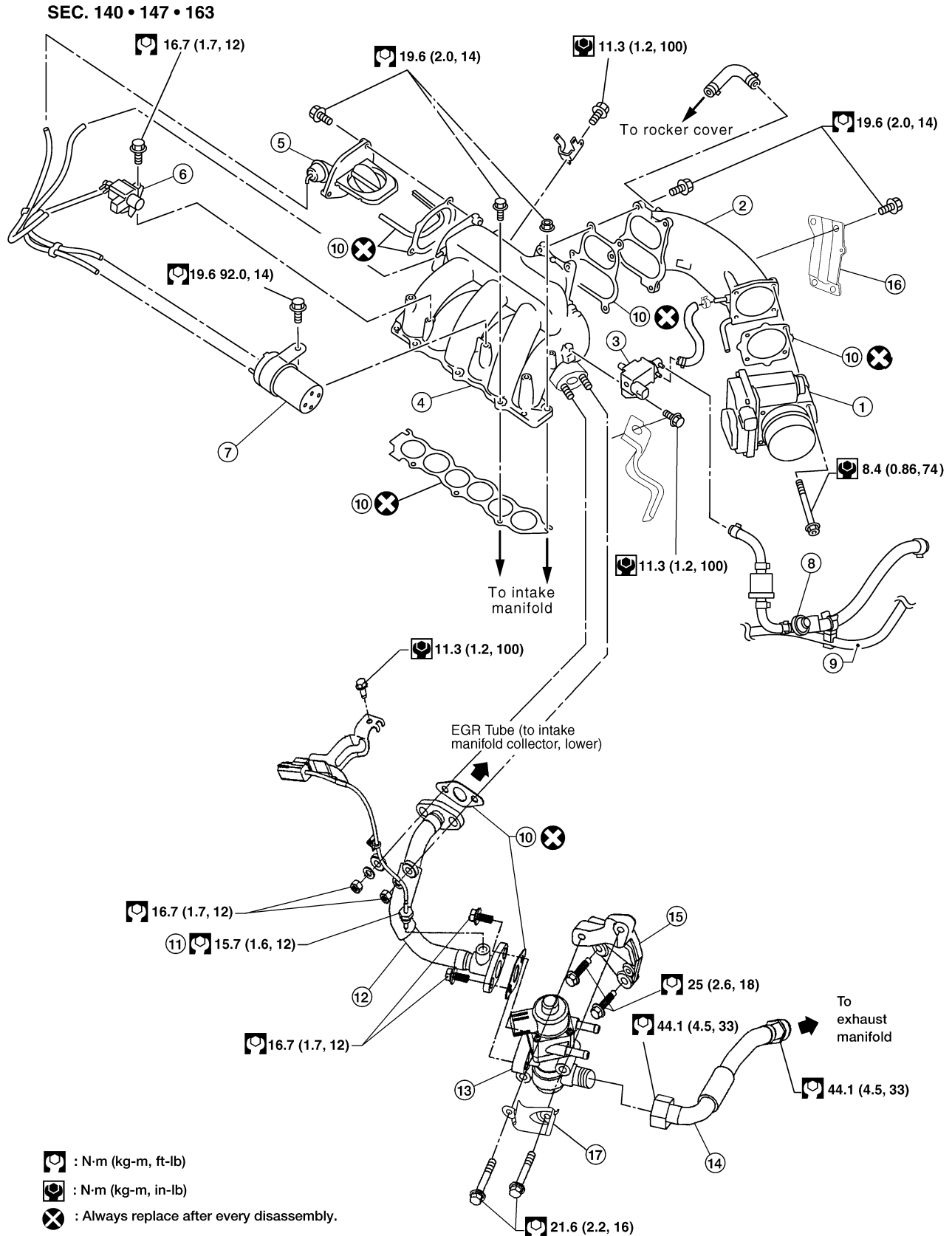

WBIA0592E

INTAKE MANIFOLD COLLECTOR

- | | | |
|---|--------------------------------------|--|
| 1. Electric throttle control actuator | 2. Intake manifold collector (upper) | 3. EVAP canister purge volume control solenoid valve |
| 4. Intake manifold collector (lower) | 5. Power valve | 6. VIAS control solenoid valve |
| 7. Vacuum tank | 8. Service port | 9. Fuel hose |
| 10. Gasket | 11. EGR temperature sensor | 12. EGR tube [to intake manifold collector (lower)] |
| 13. EGR volume control valve | 14. EGR tube (to exhaust manifold) | 15. EGR volume control valve bracket |
| 16. Intake manifold collector (upper) support bracket | 17. Washers | |

REMOVAL

WARNING:

- To avoid the danger of being scalded, never drain the coolant when the engine is hot.
- The gasket for intake manifold collector (upper) is secured together with intake manifold collector (lower) bolt. Thus, when replacing only the upper gasket the lower gasket must also be replaced.

1. Remove the cowl top and cowl top extension. Refer to [EI-19, "Removal and Installation"](#).
2. Remove the engine cover using power tool.
3. Remove air cleaner case, (upper) mass air flow sensor, and air cleaner to electric throttle control actuator tube as an assembly. Refer to [EM-16, "Removal and Installation"](#).
4. Partially drain the coolant when the engine is cool. Refer to [CO-10, "DRAINING ENGINE COOLANT"](#).
5. Disconnect the following:

- Power brake booster vacuum hose
- Coolant hoses from the intake manifold collector (upper)
- Vacuum lines from the intake manifold collector (lower) and power valve
- Fuel injector electrical connectors
- PCV hose
- Electric throttle control actuator electrical connectors
- EVAP canister purge volume control solenoid valve hose
- EGR temperature sensor electrical connector

CAUTION:

- Cover any engine openings to avoid the entry of any foreign material.

6. Remove the EGR tube [to intake manifold collector, (lower)] nuts.
7. Disconnect the power steering hose bracket from the back of the intake manifold collector (upper).
8. Remove the EVAP canister purge volume control solenoid valve bracket bolt. Position the valve aside.
9. Remove the VIAS control solenoid valve bracket bolt. Position the valve aside.
10. Remove the vacuum tank.
11. Remove the intake manifold collector (upper) support bracket from the back of the intake manifold collector (upper) using power tool.
12. Loosen the intake manifold collector (lower) bolts in the order as shown using power tool, and remove the intake manifold collector (upper and lower) and gasket.

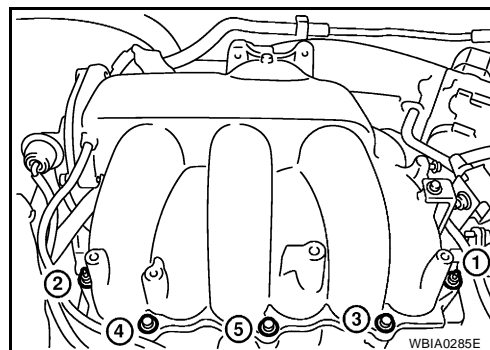
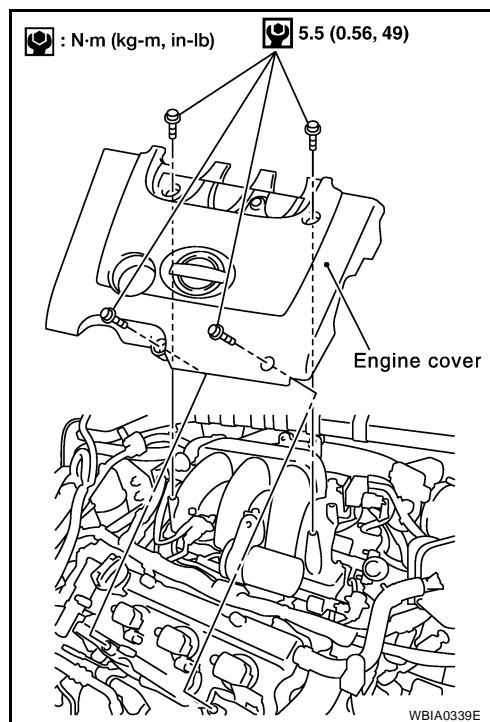

INTAKE MANIFOLD COLLECTOR

13. If necessary, remove the electric throttle control actuator bolts in the order as shown and remove the electric throttle control actuator.

CAUTION:

- Handle carefully to avoid any shock to the electric throttle control actuator.
- Do not disassemble.

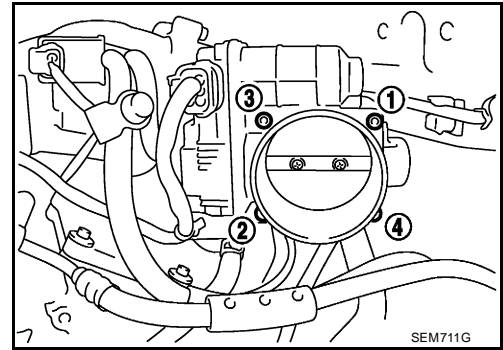

14. If necessary, remove the intake manifold collector (upper) bolts in the order as shown, using power tool and remove the intake manifold collector (upper).

CAUTION:

- Handle carefully to avoid any shock to the electric throttle control actuator, if installed.

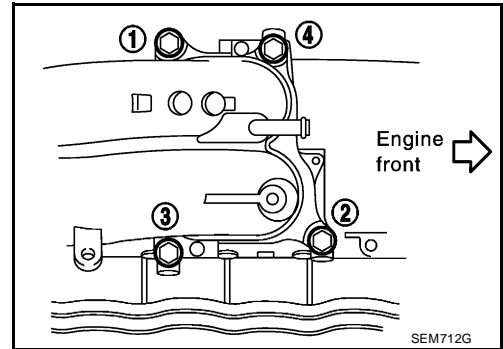

15. If necessary, remove power valve bolts in the order as shown and remove the power valve.

16. If necessary remove the following components:

- Vacuum tank
- VIAS control solenoid valve
- EVAP canister purge volume control solenoid valve

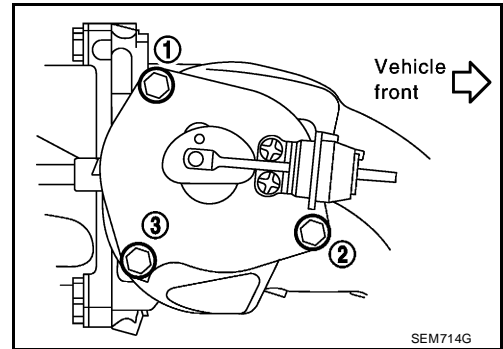

INSPECTION AFTER REMOVAL

Surface Distortion

- Using straightedge and feeler gauge, inspect the surface distortion of intake manifold collector (lower).

Limit : 0.1 mm (0.004 in)

- If it exceeds the limit, replace the intake manifold collector (lower).

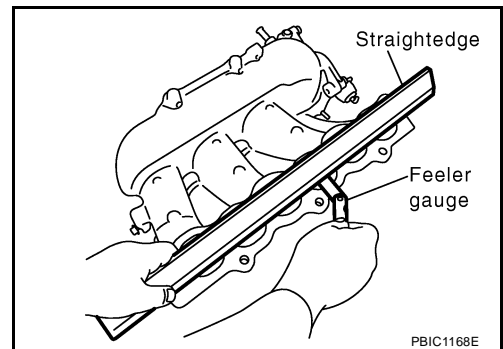

INSTALLATION

Installation is in the reverse order of removal.

NOTE:

After installation, it is necessary to re-calibrate the electric throttle control actuator as follows:

1. Perform the "Throttle Valve Closed Position Learning" when harness connector of the electric throttle control actuator is disconnected. Refer to [EC-80, "Throttle Valve Closed Position Learning"](#).
2. Perform the "Idle Air Volume Learning" when the electric throttle control actuator is replaced. Refer to [EC-80, "Idle Air Volume Learning"](#).

INTAKE MANIFOLD COLLECTOR

- If removed, install power valve bolts in the order as shown.

Power valve bolts : 19.6 N-m (2.0 kg-m, 14 ft-lb)

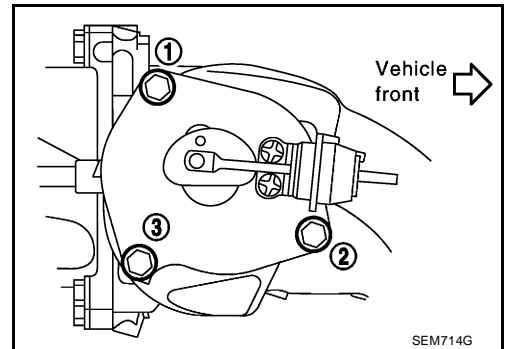

- If removed, tighten the intake manifold collector (upper) bolts in the order as shown.

Intake manifold collector (upper) bolts : 19.6 N-m (2.0 kg-m, 14 ft-lb)

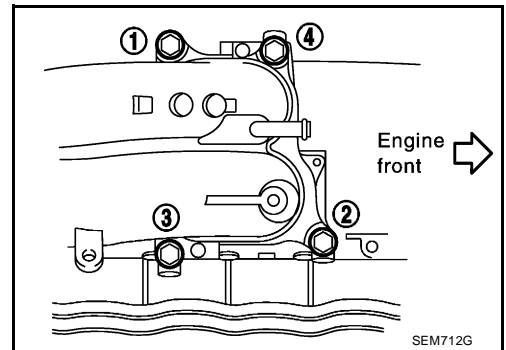

- If removed, install the electric throttle control actuator bolts in the order as shown. Install gasket with three protrusions facing down.

Electric throttle control actuator bolts : 8.4 N-m (0.86 kg-m, 74 in-lb)

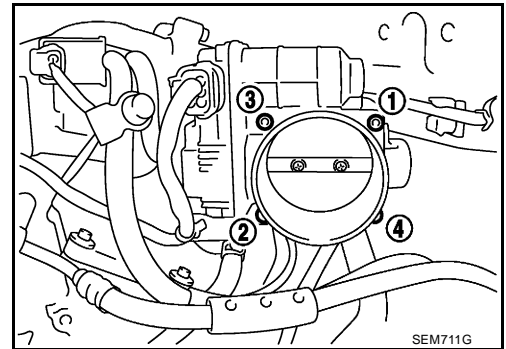

- Install the intake manifold collector (lower) bolts in the order as shown.

Intake manifold collector (lower) bolts : 19.6 N-m (2.0 kg-m, 14 ft-lb)

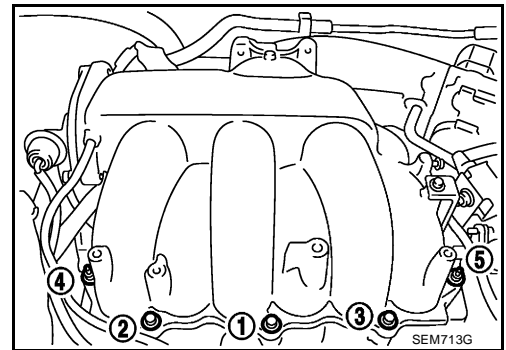

A
EM
C
D
E
F
G
H
I
J
K
L
M

EGR VOLUME CONTROL VALVE

EGR VOLUME CONTROL VALVE

PF14710

Removal and Installation

EBS00PRK

SEC. 147

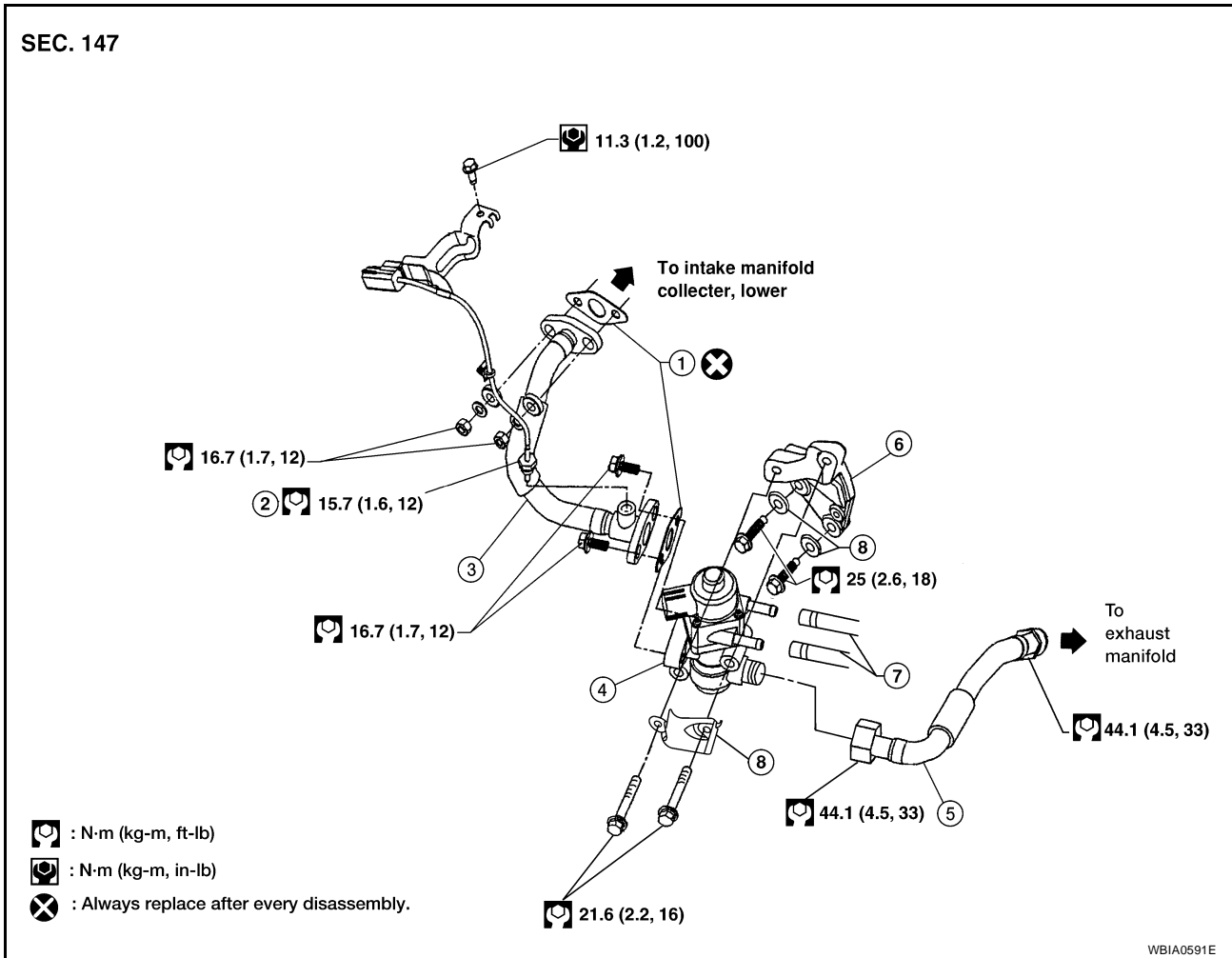

WBIA0591E

- | | | |
|-----------------------------|-----------------------------------|--|
| 1. Gasket | 2. EGR temperature sensor | 3. EGR tube [to intake manifold collector (lower)] |
| 4. EGR volume control valve | 5. EGR tube (to exhaust manifold) | 6. EGR volume control valve bracket |
| 7. Coolant lines | 8. Washers | |

EGR VOLUME CONTROL VALVE

REMOVAL

1. Remove the engine cover using power tool.
2. Remove air cleaner case (upper), mass air flow sensor, and air cleaner to electric throttle control actuator tube as an assembly. Refer to [EM-16, "Removal and Installation"](#).
3. Partially drain the coolant when the engine is cool. Refer to [CO-10, "DRAINING ENGINE COOLANT"](#).

CAUTION:

Cover any engine openings to avoid the entry of any foreign material.

4. Disconnect the EGR temperature sensor electrical connector and bracket.
5. If necessary, remove the EGR temperature sensor.
6. Disconnect the EGR volume control valve electrical connector.
7. Remove the EGR tube [to intake manifold collector (lower) bolts at the intake manifold collector (lower).
8. Remove the EGR tube (to intake manifold collector (lower) bolts at the EGR volume control valve and remove the tube.
9. Loosen the EGR tube (to exhaust manifold) to EGR volume control valve.
10. If necessary remove the EGR tube (to exhaust manifold) as follows:
 - a. Remove the cowl top and cowl top extension. Refer to [EI-19, "Removal and Installation"](#).
 - b. Disconnect the EGR tube (to exhaust manifold) to EGR volume control valve fitting.
 - c. Disconnect the air fuel ratio (A/F) sensor 1 (bank 1).
 - d. Remove the RH heat shield.
 - e. Remove the EGR tube (to exhaust manifold) to exhaust manifold fitting.
11. Disconnect the coolant lines at the EGR volume control valve.
12. Remove the EGR volume control valve bolts and the valve.

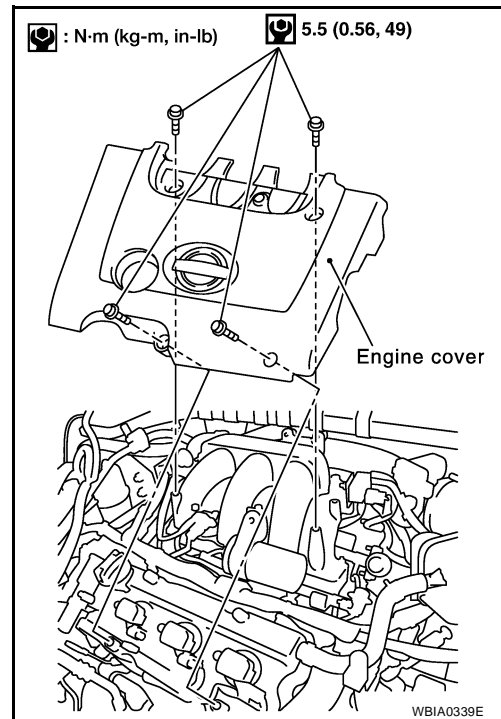

INSTALLATION

Installation is in the reverse order of removal.

- Tighten the RH heat shield bolts to specification.

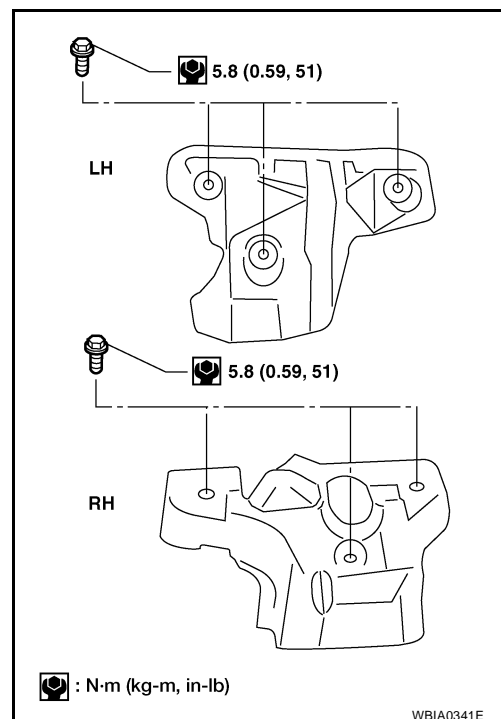

INTAKE MANIFOLD

PF:14003

INTAKE MANIFOLD

Removal and Installation

EBS00PRL

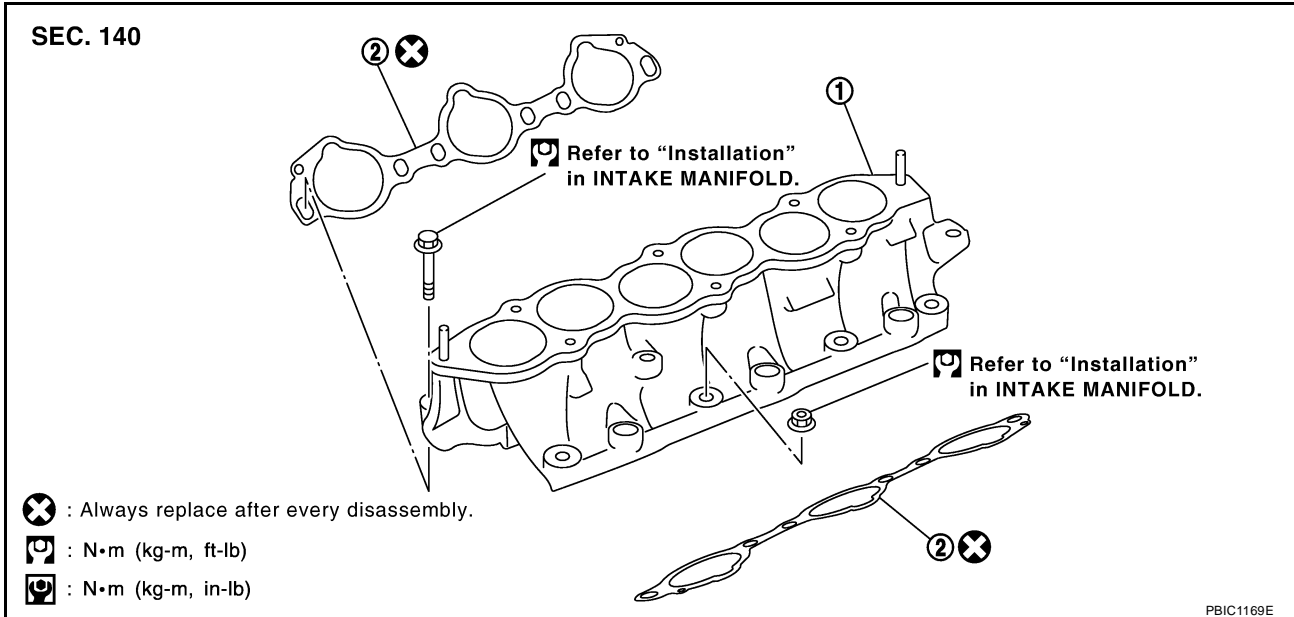

1. Intake manifold

2. Gasket

REMOVAL

1. Release the fuel pressure. Refer to [EC-82, "FUEL PRESSURE RELEASE"](#).
2. Remove the intake manifold collector (upper and lower). Refer to [EM-18, "Removal and Installation"](#).
3. Remove the fuel rail with the fuel injectors. Refer to [EM-40, "Removal and Installation"](#).
4. Loosen the intake manifold nuts and bolts in the order as shown using power tool, and remove the intake manifold.

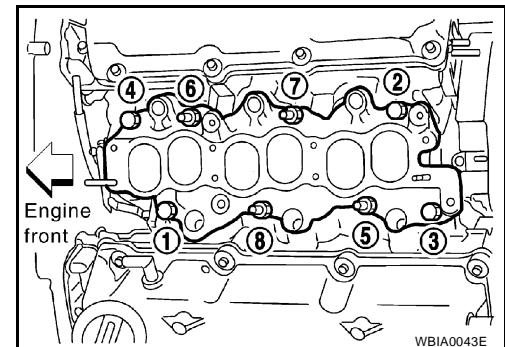

INTAKE MANIFOLD

INSPECTION AFTER REMOVAL

Surface Distortion

Using straightedge and feeler gauge, inspect the surface distortion of both the intake manifold and the intake manifold collector (lower).

Limit : 0.1 mm (0.004 in)

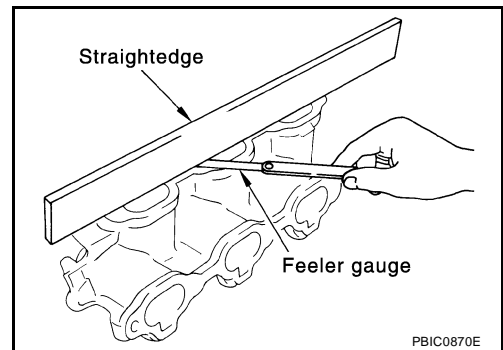
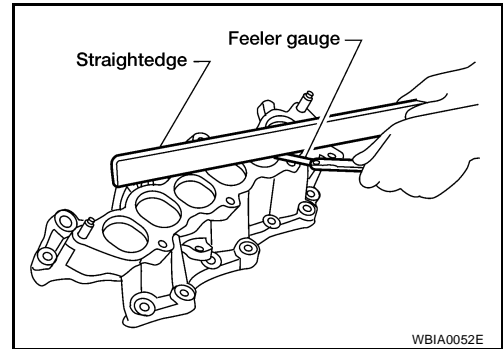

INSTALLATION

Installation is in the reverse order of removal.

- If removed, install the stud bolts.

Stud bolts : 10.8 N·m (1.1 kg-m, 96 in-lb)

- Install intake manifold nuts and bolts in the order in two steps as shown.

Step 1 : 7.4 N·m (0.75 kg-m, 65 in-lb)

Step 2 : 29 N·m (3.0 kg-m, 21 ft-lb)

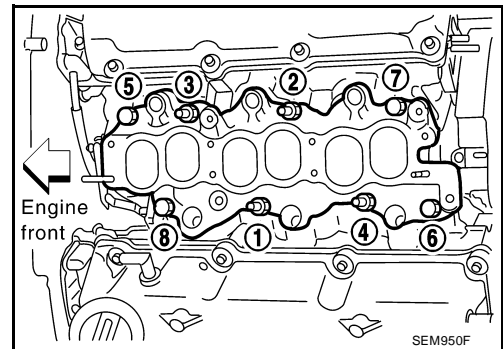

EXHAUST MANIFOLD AND THREE WAY CATALYST

EXHAUST MANIFOLD AND THREE WAY CATALYST

PF14004

Removal and Installation

EBS00PRM

SEC. 140 • 208

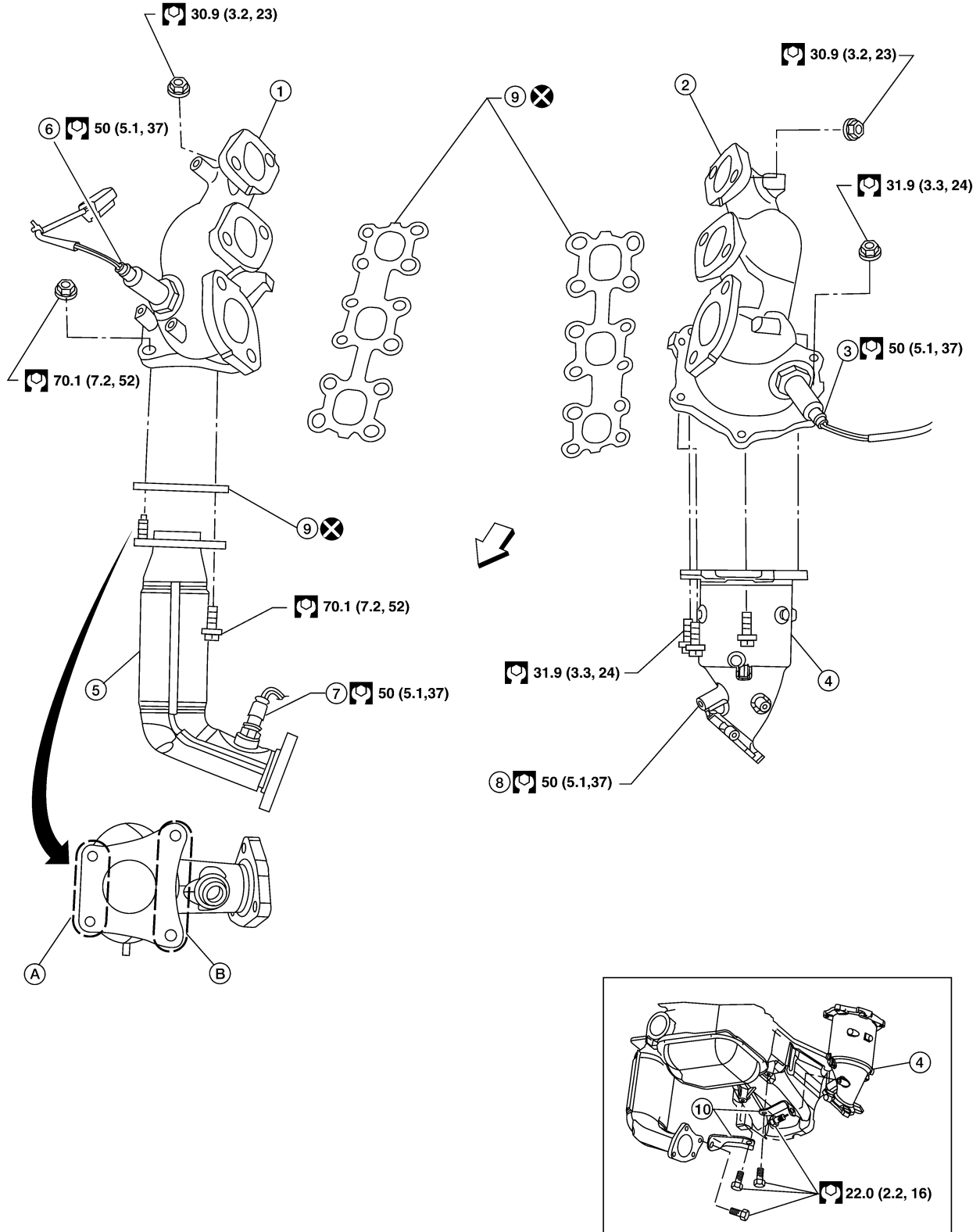

WBIA0743E

EXHAUST MANIFOLD AND THREE WAY CATALYST

- | | | |
|---|---|---|
| 1. Exhaust manifold (RH bank) | 2. Exhaust manifold (LH bank) | 3. Air fuel ratio (A/F) sensor 1 (bank 2) |
| 4. Three way catalyst (manifold) (bank 2) | 5. Three way catalyst (manifold) (bank 1) | 6. Air fuel ratio (A/F) sensor 1 (bank 1) |
| 7. Heated oxygen sensor 2 (bank 1) | 8. Heated oxygen sensor 2 (bank 2) | 9. Gasket |
| 10. Three way catalyst supports | A. Stud | B. Bolt |
- ← Engine Front

REMOVAL

WARNING:

- Perform the work when the exhaust and cooling system have completely cooled down.
- When removing the front and rear engine mounting through bolts and nuts, lift the engine up slightly for safety. For engine slingers, refer to [EM-113, "REMOVAL"](#).

1. Disconnect battery. Refer to [SC-9, "Removal and Installation"](#).
2. Remove cowl top. Refer to [EI-19, "Removal and Installation"](#).
3. Disconnect air fuel ratio (A/F) sensor 1 (bank 2) connector.
4. Remove the front wheel and tires using power tool.
5. Remove the engine undercover.
6. Remove the inner wheel well splash shields.
7. If removing only air fuel ratio (A/F) sensor 1 (bank 2) do so at this time through the wheel well opening, using Tool.

Tool number : KV991J0050 (J-44626)

8. If removing the exhaust manifold (LH bank), remove the radiator and cooling fan assembly. Refer to [CO-15, "Removal and Installation"](#).
9. Remove the front exhaust tube. Refer to [EX-3, "Removal and Installation"](#).
10. If removing the exhaust manifold (RH), remove the front suspension member. Refer to [FSU-15, "Removal and Installation"](#).
11. Remove the bank 1 (1) and bank 2 (2) three way catalyst manifolds support bolts in the order as shown.

- ←: Engine front

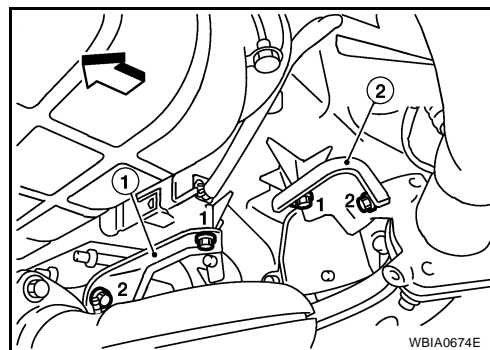

12. Remove heated oxygen sensor 2 (bank 1), heated oxygen sensor 2 (bank 2), air fuel ratio (A/F) sensor 1 (bank 1) and air fuel ratio (A/F) sensor 1 (bank 2).
 - a. Remove harness connector of each sensor, and disconnect the harness from the bracket and middle clamp.
 - b. Remove both heated oxygen sensors and air fuel ratio (A/F) sensors using Tool.

Tool numbers : KV10114400 (J-38365)

CAUTION:

- Be careful not to damage heated oxygen sensors or air fuel ratio (A/F) sensors.
 - Discard any heated oxygen sensor which has been dropped from a height of more than 0.5 m (19.7 in) onto a hard surface such as a concrete floor; replace with a new sensor.
13. Remove exhaust manifold and three way catalyst manifold heat shields using power tool.
 14. Remove the three way catalyst (manifold) (bank 1) and three way catalyst (manifold) (bank 2) by loosening the bolts first and then removing the nuts and through bolts using power tool.

EXHAUST MANIFOLD AND THREE WAY CATALYST

15. Remove the RH bank(1) and LH bank (2) exhaust manifolds. Loosen the exhaust manifold nuts in the order as shown using power tool.

- ⇐: Engine front

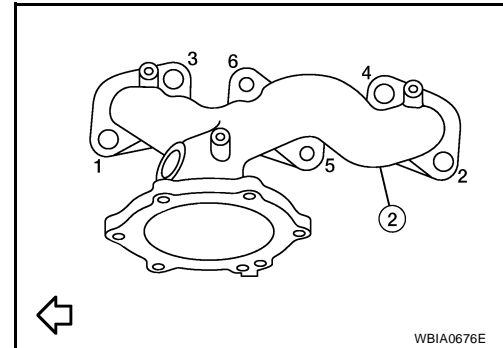
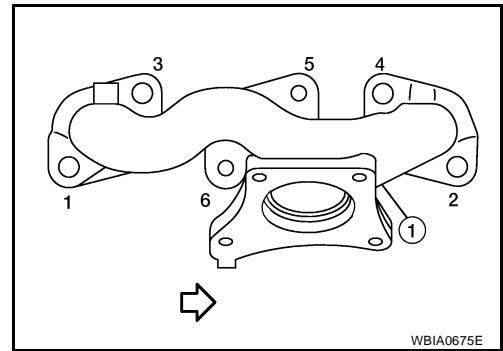

INSPECTION AFTER REMOVAL

Surface Distortion

- Use a reliable straightedge and feeler gauge to check the flatness of the exhaust manifold mating surfaces.

Limit : 0.3 mm (0.012 in)

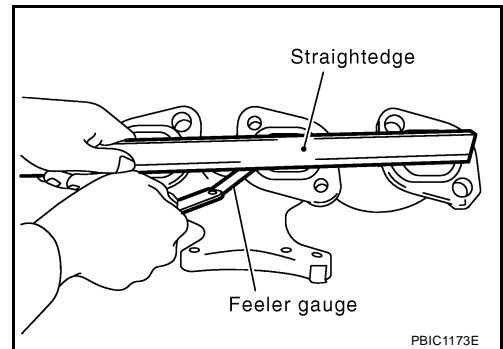

INSTALLATION

Installation is in the reverse order of removal.

- ⇐: Engine front
- Install the RH bank (1) and LH bank (2) exhaust manifold nuts in the order as shown.

CAUTION:

- Before installing a heated oxygen sensor or air fuel ratio (A/F) sensor, clean the exhaust manifold threads using Tool, and apply anti-seize lubricant.

Tool numbers : J-43897-18

: J-43897-12

- Do not over-tighten the air fuel ratio (A/F) sensor or heated oxygen sensors. Doing so may cause damage.

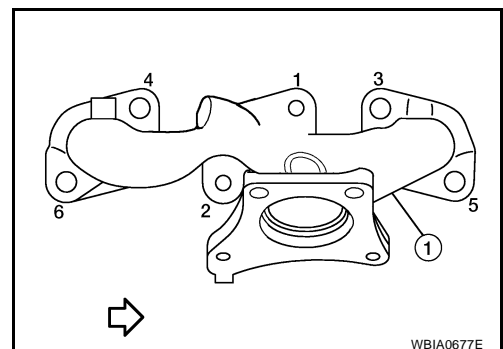

EXHAUST MANIFOLD AND THREE WAY CATALYST

Tool numbers : KV10114400 (J-38365)

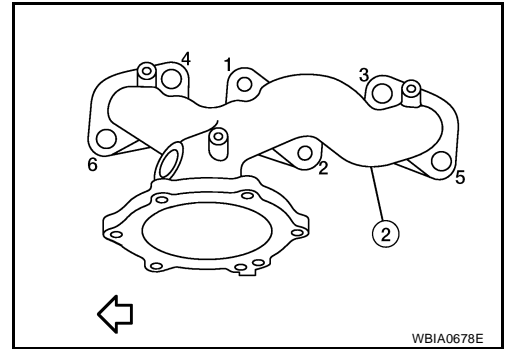

- Install the bank 1 (1) and bank 2 (2) three way catalyst support bolts in the order as shown.

Three way catalyst support bolts : 22.0 N·m (2.2 kg-m, 16 ft-lb)

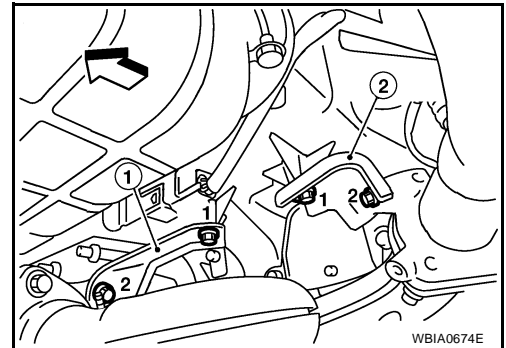

- Install the exhaust manifold heat shield bolts.

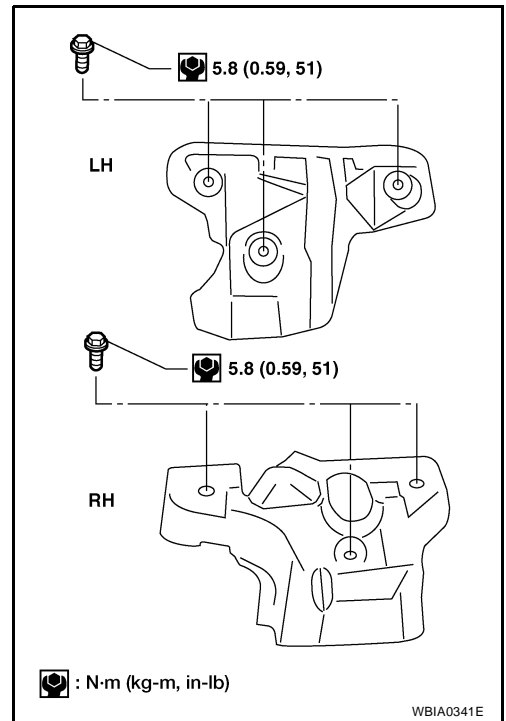

- Install the three way catalyst manifolds heat shield bolts.

Three way catalyst manifold heat shield bolts : 8.3 N·m (0.85 kg-m, 73 in-lb)

A
EM
C
D
E
F
G
H
I
J
K
L
M

OIL PAN AND OIL STRAINER

PF1:11110

OIL PAN AND OIL STRAINER

Removal and Installation

EBS00PRN

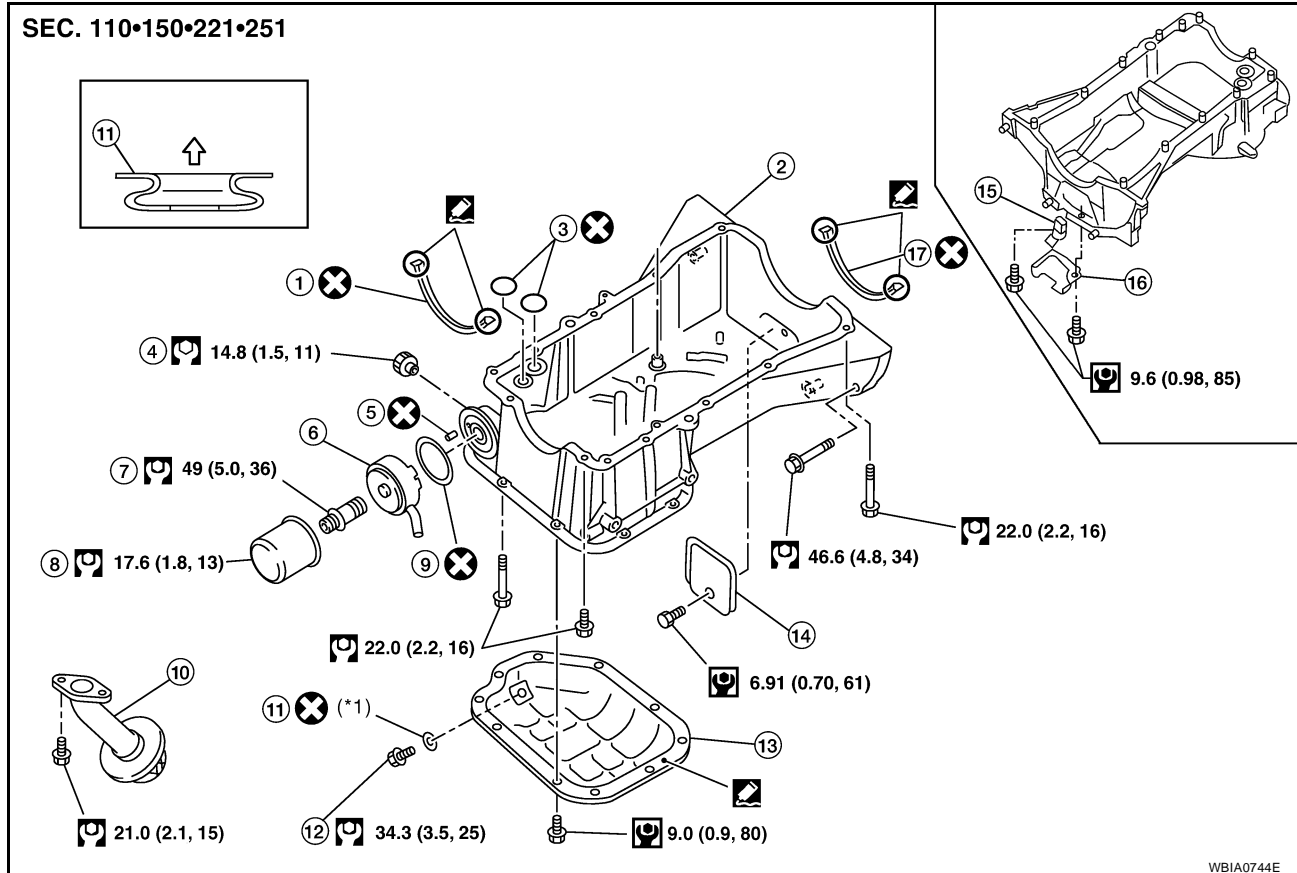

WBIA0744E

- | | | |
|--|-----------------------------------|--------------------------------------|
| 1. Front cover gasket | 2. Upper oil pan | 3. O-ring |
| 4. Oil pressure switch | 5. Relief valve | 6. Oil cooler |
| 7. Oil cooler connection | 8. Oil filter | 9. Gasket |
| 10. Oil strainer (connects to oil pump body) | 11. Gasket (← oil pan side) | 12. Drain plug |
| 13. Lower oil pan | 14. Rear cover plate | 15. Crankshaft position sensor (POS) |
| 16. Crankshaft position sensor (POS) shield | 17. Rear oil seal retainer gasket | ← Oil pan side |

REMOVAL

WARNING:

- You should not remove the oil pan until the exhaust system and cooling system have completely cooled off.
- When removing the front and rear engine mounting through bolts and nuts, lift the engine up slightly for safety.

CAUTION:

When removing the upper oil pan from the engine, first remove the crankshaft position sensor (POS). Be careful not to damage sensor edges or signal plate teeth.

1. Remove the front RH wheel and tire using power tool.
2. Drain engine oil. Refer to [LU-9, "Changing Engine Oil"](#).
3. Drain the engine coolant. Refer to [CO-10, "DRAINING ENGINE COOLANT"](#).
4. Remove the oil dipstick.
5. Remove the engine undercover.
6. Remove the RH inner fender splash shield.
7. Remove the A/C drive belt. Refer to [EM-15, "REMOVAL"](#).

OIL PAN AND OIL STRAINER

8. Remove the front exhaust tube. Refer to [EX-3, "Removal and Installation"](#) .
9. Remove coolant pipe bolts.
10. Discharge and recover the A/C refrigerant. Refer to [ATC-193, "HFC-134a \(R-134a\) Service Procedure"](#) .
11. Remove the A/C compressor using power tools. Refer to [ATC-197, "Removal and Installation for Compressor"](#) .
12. Remove oil cooler from the upper oil pan. Refer to [LU-16, "REMOVAL"](#) .
13. Remove the oil pressure switch, and the crankshaft position sensor (POS) from the upper oil pan.
14. Remove the front drive shafts. Refer to [FAX-8, "FRONT DRIVE SHAFT"](#) .
15. Remove the front suspension member. Refer to [FSU-15, "Removal and Installation"](#) .
16. Disconnect the heated oxygen sensors and air flow ratio (A/F) sensors and remove the two three way catalysts manifold from the exhaust manifolds using power tool. Refer to [EX-3, "Removal and Installation"](#) .
17. Remove the rear cover plate from the upper oil pan.

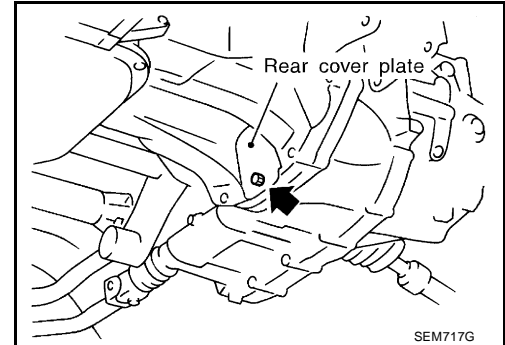

18. Loosen the lower oil pan bolts using power tool in order as shown.

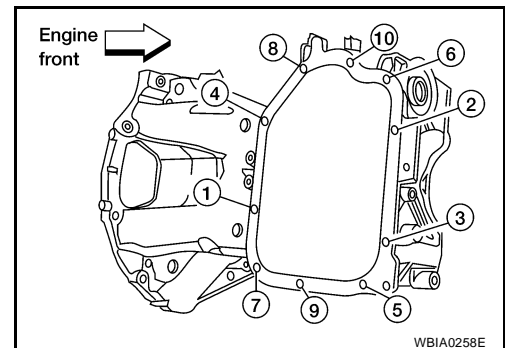

19. Remove the lower oil pan.

- a. Insert Tool between the lower oil pan and the upper oil pan.
 - After removing the bolts and nuts, separate the mating surface using Tool and remove the liquid gasket sealing.

Tool number : KV10111100 (J-37228)

- In areas where the Tool is difficult to use, use a plastic hammer to lightly tap the Tool (1) where the Silicone RTV Sealant is applied. Use a plastic hammer to slide the Tool (2) by tapping on the side.

CAUTION:

If for some unavoidable reason a tool such as a flat-bladed screwdriver is used, be careful not to damage the mating surfaces.

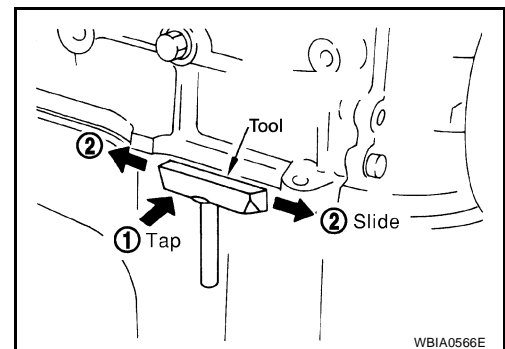

OIL PAN AND OIL STRAINER

20. Remove the four upper oil pan to transaxle bolts.

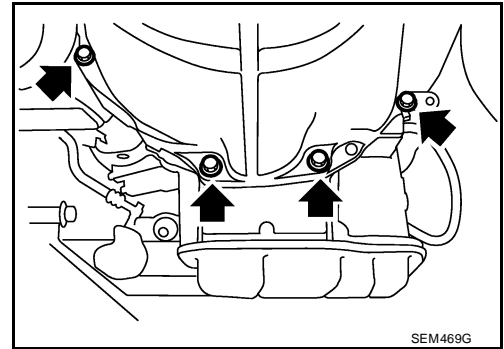

21. Remove the upper oil pan.

a. Loosen the bolts in the order as shown, using power tool.

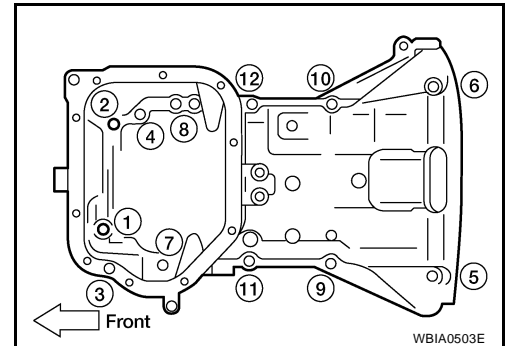

b. Insert a suitable tool into the notch (1) of the upper oil pan as shown.

c. Pry off the upper oil pan by moving the suitable tool up and down (2) as shown.

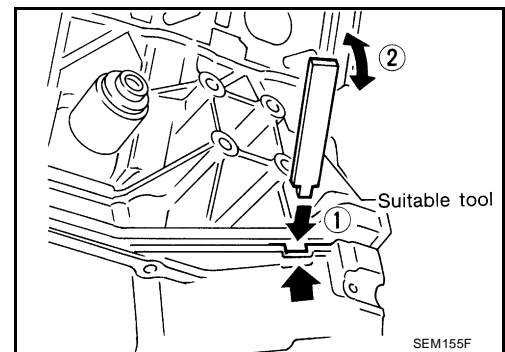

22. Remove the O-ring seals from the bottom of the cylinder block and oil pump housing, use new O-rings for installation.

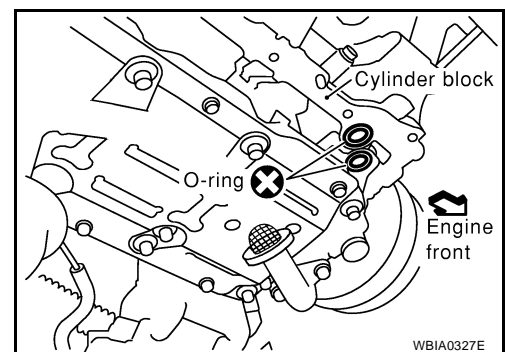

23. Remove front cover gasket and rear oil seal retainer gasket.

24. Remove the oil strainer.

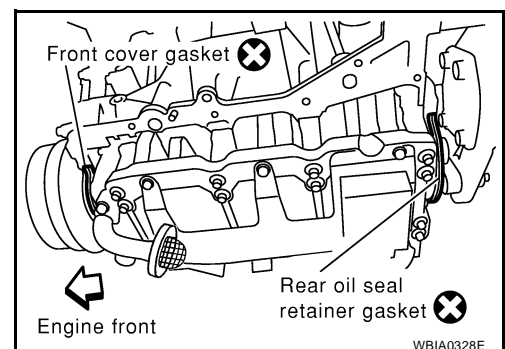

OIL PAN AND OIL STRAINER

25. If re-installing the original oil pan, remove the old sealant from the mating surfaces using a scraper.

- Also remove the old sealant from mating surface of the cylinder block.
- Remove the old sealant from the bolt holes and threads.

CAUTION:

Do not scratch or damage the mating surfaces when cleaning off the old sealant.

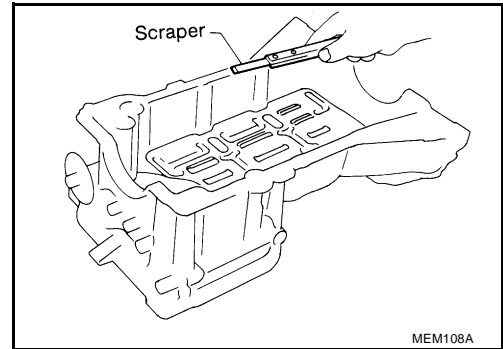

INSPECTION AFTER REMOVAL

Clean oil strainer of any foreign material.

INSTALLATION

CAUTION:

Wait at least 30 minutes after completing installation before refilling the engine with oil.

1. Install oil strainer refer to [EM-30, "Removal and Installation"](#) .
2. Apply Genuine Silicone RTV Sealant or equivalent, to the front cover gasket and the rear oil seal retainer gasket as shown. Refer to [GI-46, "RECOMMENDED CHEMICAL PRODUCTS AND SEALANTS"](#) .

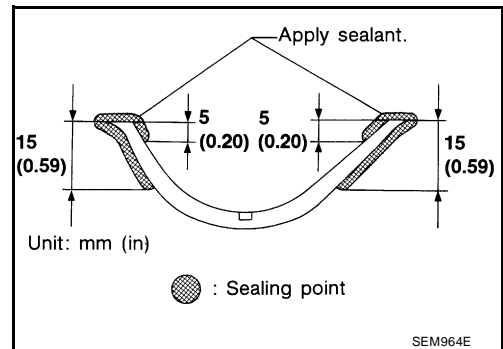

3. Install a new front cover gasket and rear oil seal retainer gasket.

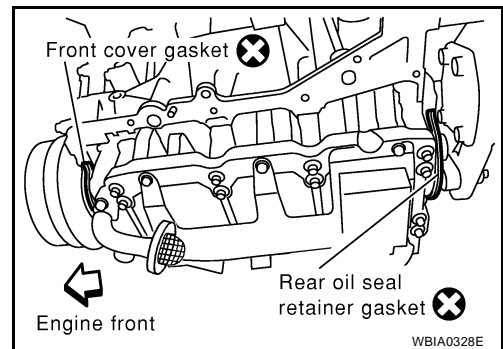

4. Apply a bead of sealant to the cylinder block mating surface of the upper oil pan as shown.

- Use Genuine Silicone RTV Sealant, or equivalent. Refer to [GI-46, "RECOMMENDED CHEMICAL PRODUCTS AND SEALANTS"](#) .
- Be sure the sealant is applied as shown, and the sealant is 4.0 - 5.0 mm (0.157 - 0.197 in) or 4.5 - 5.5 mm (0.177 - 0.217 in) wide.
- Installation must be done within 5 minutes after applying sealant.

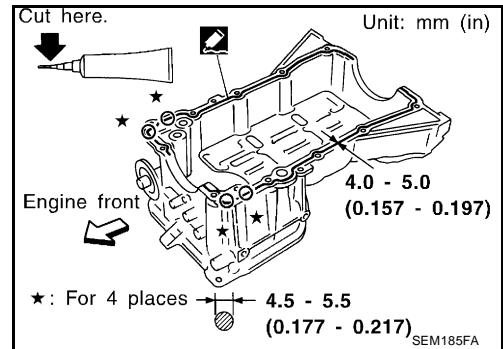

OIL PAN AND OIL STRAINER

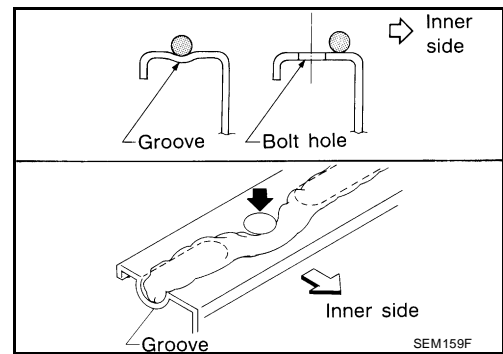

5. Install new O-rings on the cylinder block and oil pump body.

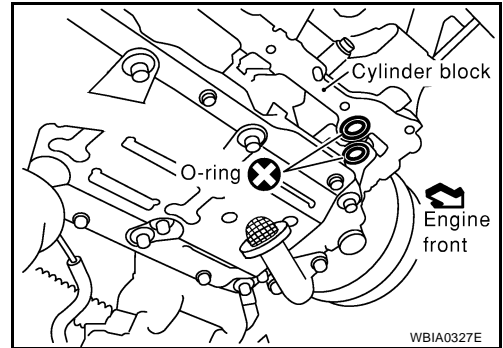

6. Install the upper oil pan.
● Tighten upper oil pan bolts in the order as shown refer to [EM-30, "Removal and Installation"](#).

CAUTION:

Wait at least 30 minutes before refilling the engine with oil.

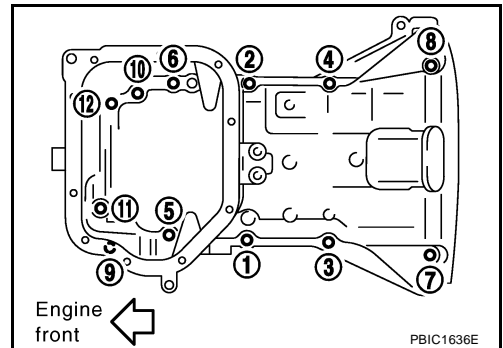

7. Install the four upper oil pan to transaxle bolts. Refer to [EM-116, "INSTALLATION"](#).

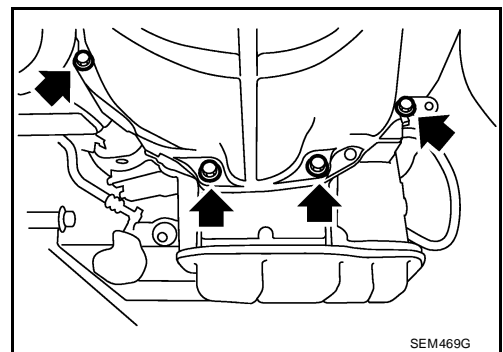

8. Apply a continuous bead of sealant to the lower oil pan.
● Use Genuine Silicone RTV Sealant, or equivalent. Refer to [GI-46, "RECOMMENDED CHEMICAL PRODUCTS AND SEALANTS"](#).
● Be sure the sealant is 4.5 - 5.5 mm (0.177 - 0.217 in) wide.
● Installation must be done within 5 minutes after applying sealant.

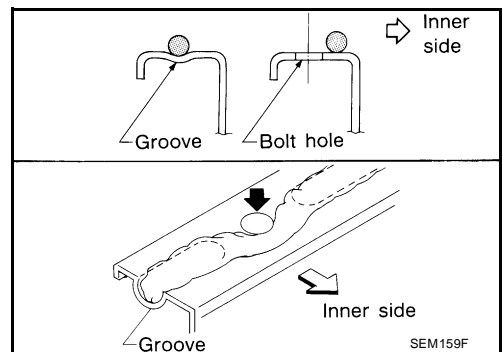

OIL PAN AND OIL STRAINER

9. Install the lower oil pan. Tighten the lower oil pan bolts in order as shown refer to [EM-30, "Removal and Installation"](#) .

CAUTION:

Wait at least 30 minutes before refilling the engine with oil.

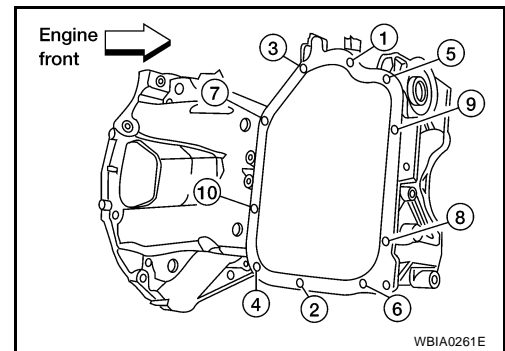

10. Install rear plate cover refer to [EM-30, "Removal and Installation"](#) .
11. Installation of the remaining components is in the reverse order of removal.

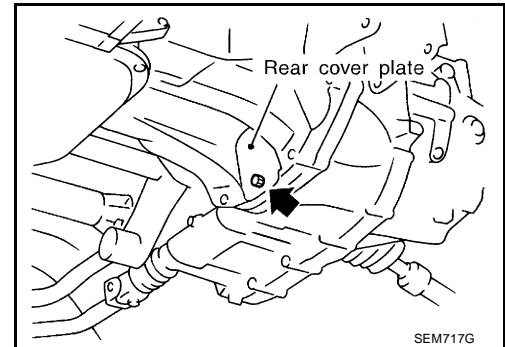

INSPECTION AFTER INSTALLATION

- Start the engine and check for leaks. Refer to [LU-9, "Changing Engine Oil"](#) .
- Inspect the engine oil level. Refer to [LU-9, "Changing Engine Oil"](#) .

CAUTION:

Wait at least 30 minutes before refilling the engine with oil.

A
EM
C
D
E
F
G
H
I
J
K
L
M

IGNITION COIL

IGNITION COIL

PF2:22448

Removal and Installation

EBS00PRO

SEC. 111

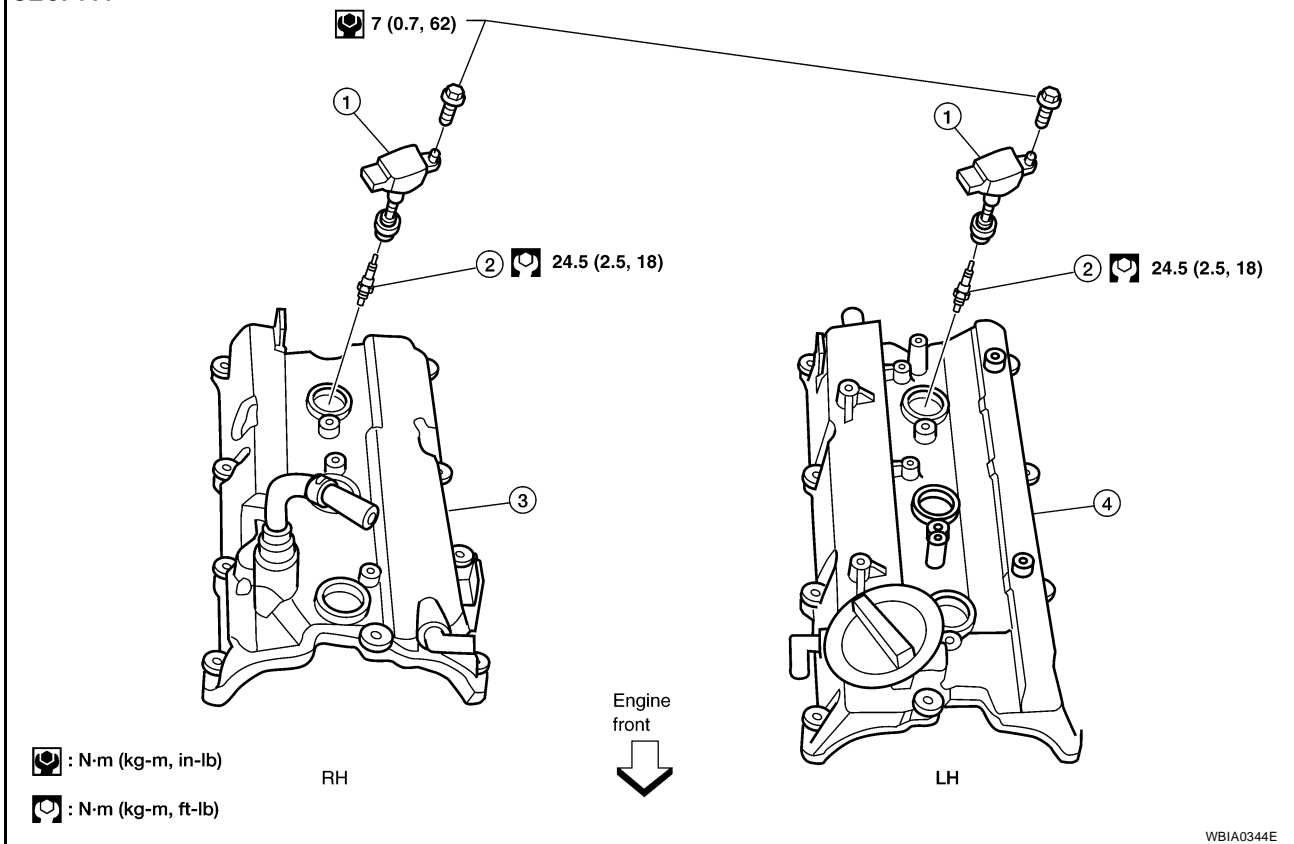

1. Ignition coil
2. Spark plug
3. Rocker cover (RH)
4. Rocker cover (LH)

REMOVAL

1. Remove the engine cover using power tool.
2. Drain engine coolant. Refer to [CO-10, "DRAINING ENGINE COOLANT"](#).
3. Disconnect the mass air flow sensor electrical connector and remove the air cleaner case (upper), mass air flow sensor and air cleaner to electric throttle control actuator tube. Refer to [EM-16, "Removal and Installation"](#).
4. Remove the intake manifold collector (upper), gasket, and electric throttle control actuator. Refer to [EM-18, "Removal and Installation"](#).
5. Remove the six ignition coils.

CAUTION:
Do not shock it.

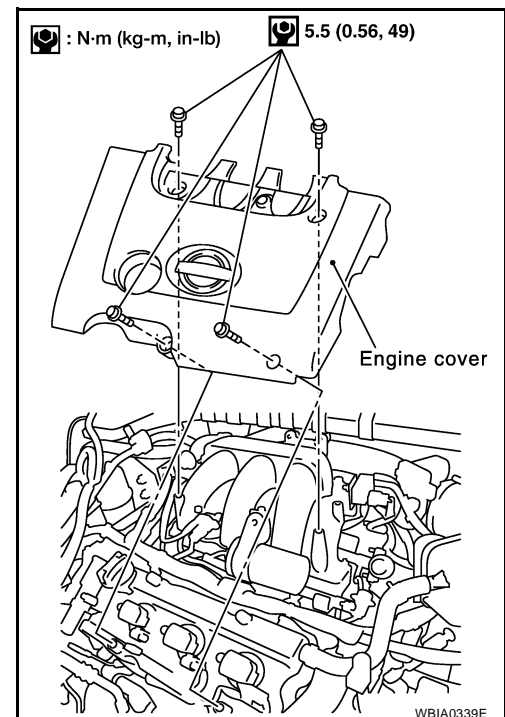

IGNITION COIL

INSTALLATION

Installation is in the reverse order of removal.

A

EM

C

D

E

F

G

H

I

J

K

L

M

SPARK PLUG (PLATINUM-TIPPED TYPE)

SPARK PLUG (PLATINUM-TIPPED TYPE)

PF22401

Removal and Installation

EBS00PRP

SEC. 111

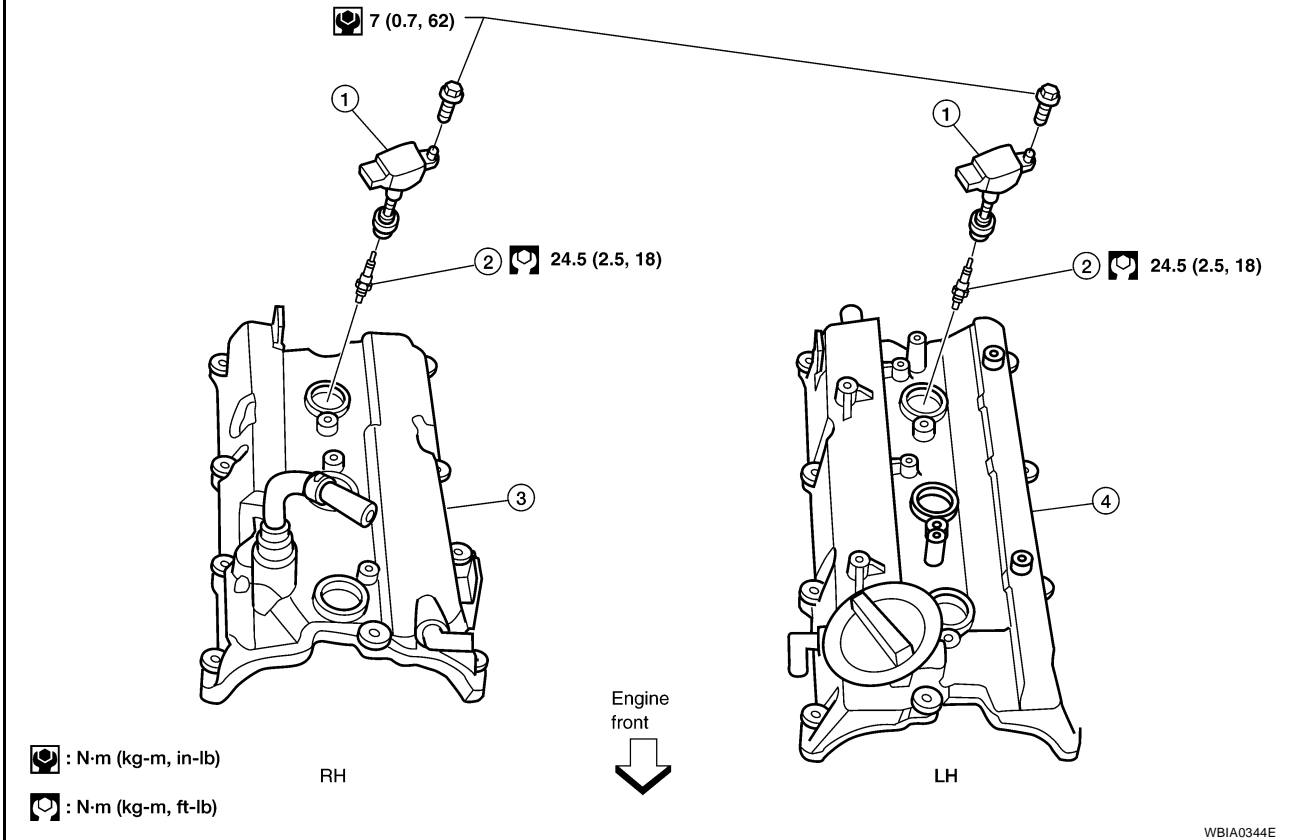

1. Ignition coil
2. Spark plug
3. Rocker cover (RH)
4. Rocker cover (LH)

REMOVAL

1. Remove the engine cover, using power tool.
2. Drain the engine coolant. Refer to [CO-10, "DRAINING ENGINE COOLANT"](#).
3. Disconnect the mass air flow sensor electrical connector and remove the air cleaner case (upper), mass air flow sensor and air cleaner to electric throttle control actuator tube. Refer to [EM-16, "Removal and Installation"](#).
4. Remove the intake manifold collector (upper), gasket, and electric throttle control actuator. Refer to [EM-18, "Removal and Installation"](#).
5. Remove the six ignition coils.

CAUTION:
Do not shock them.

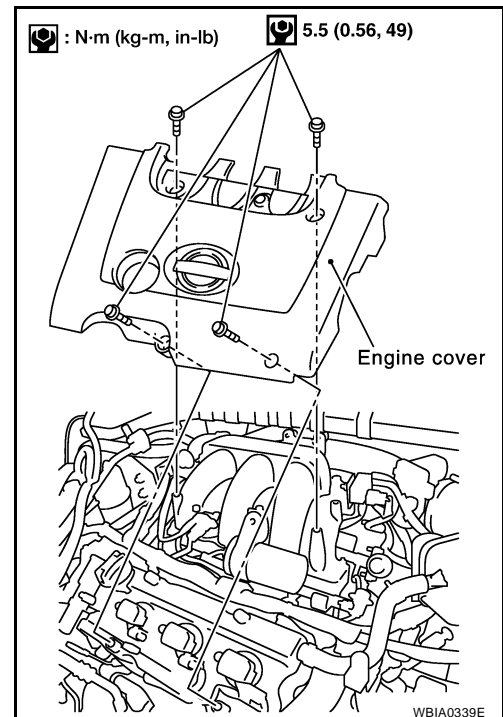

SPARK PLUG (PLATINUM-TIPPED TYPE)

6. Remove the six spark plugs using a suitable tool.
- If replacing the spark plugs use the correct spark plug for maximum performance. Refer to [MA-20, "Changing Spark Plugs \(Platinum - Tipped Type\)"](#).

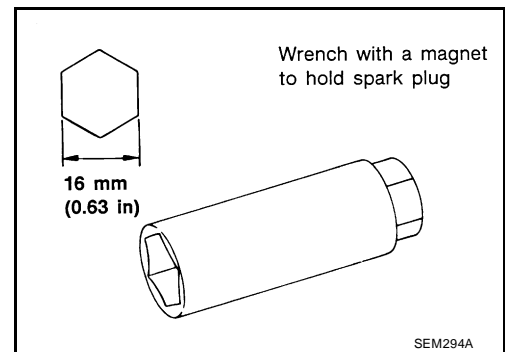

INSPECTION AFTER REMOVAL

CAUTION:

- Do not use a wire brush for cleaning.
- Do not drop or shock spark plug.

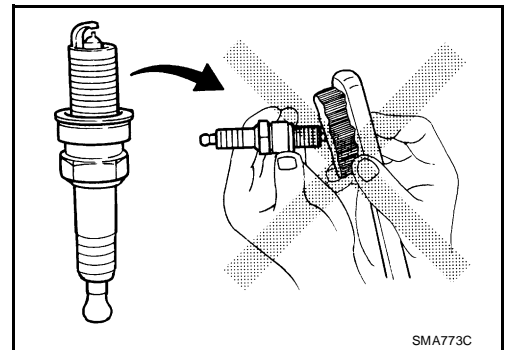

If plug tip is covered with carbon, a spark plug cleaner may be used.

Cleaner air pressure : less than 588 kPa (6 kg/cm² , 85 psi)

Cleaning time : less than 20 seconds

Checking and adjusting plug gap is not required between change intervals.

Gap (nominal) : 1.1 mm (0.043 in)

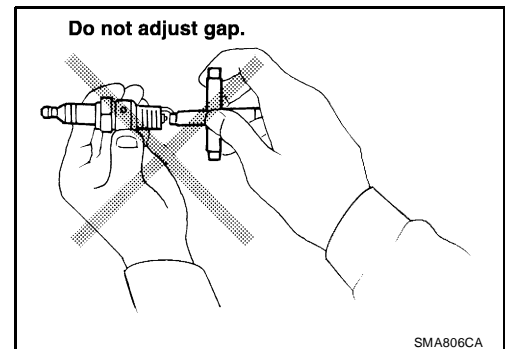

INSTALLATION

Installation is in the reverse order of removal.

- Use standard type spark plug for normal driving conditions. Refer to [EM-146, "SPARK PLUG"](#).
- The hot type spark plug is suitable when fouling occurs with the standard type spark plug under conditions such as:
 - Frequent engine starts
 - Low ambient temperatures
- The cold type spark plug is suitable when engine spark knock occurs with the standard type spark plug under conditions such as:
 - Extended highway driving
 - Frequent high engine revolution

FUEL INJECTOR AND FUEL TUBE

PF16600

FUEL INJECTOR AND FUEL TUBE

Removal and Installation

EBS00PRO

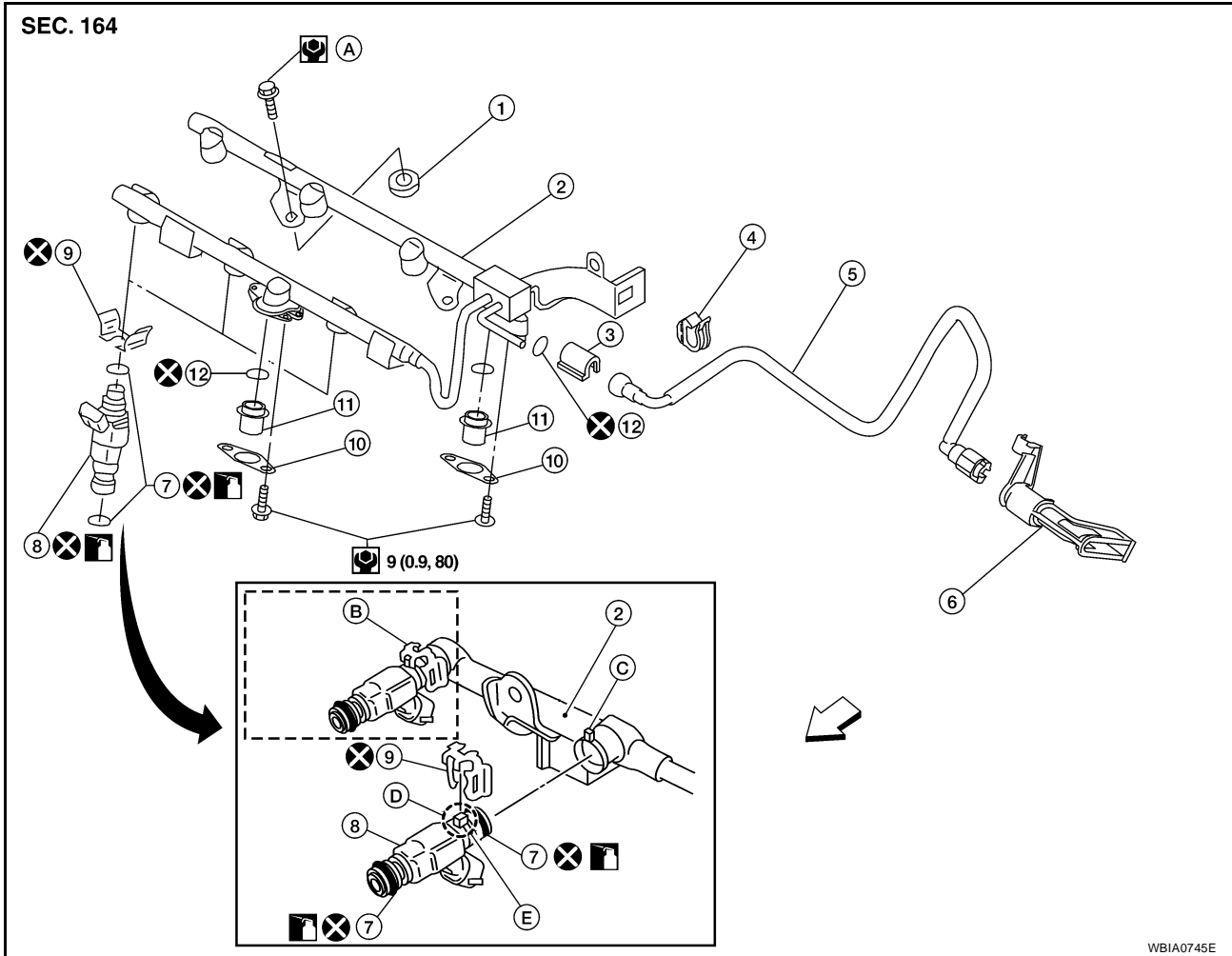

- | | | |
|--------------------------|-----------------------------------|-------------------------|
| 1. Insulator | 2. Fuel tube assembly | 3. Quick connector cap |
| 4. Clip | 5. Fuel hose | 6. Quick connector cap |
| 7. O-ring | 8. Fuel injector | 9. Clip |
| 10. Fuel damper retainer | 11. Fuel damper | 12. O-ring |
| ← Front | A. Refer to EM-41 | B. Installed condition |
| C. Protrusion | D. Alignment protrusion | E. Clip mounting groove |

CAUTION:

- Apply new engine oil when installing the parts as specified to do so.
- Do not remove or disassemble parts unless instructed as shown.

REMOVAL

1. Release the fuel pressure. Refer to [EC-82, "FUEL PRESSURE RELEASE"](#).
2. Remove the intake manifold collector (upper and lower). Refer to [EM-18, "Removal and Installation"](#).
3. Disconnect the fuel quick connector on the engine side.
 - Using Tool perform the following steps to disconnect the quick connector.

Tool number : — (J-45488)

FUEL INJECTOR AND FUEL TUBE

- a. Remove quick connector cap.

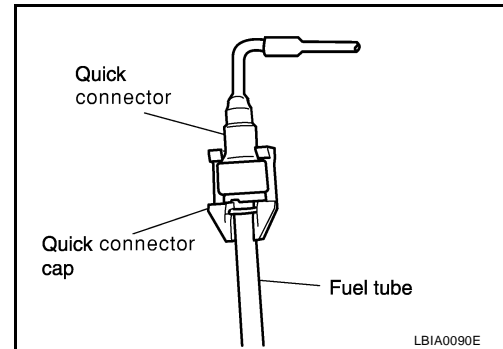

- b. With the sleeve side of Tool facing quick connector, install Tool onto fuel tube.
 c. Insert Tool into quick connector until sleeve contacts and goes no further. Hold the Tool on that position.

CAUTION:

Inserting the Tool hard will not disconnect quick connector. Hold Tool where it contacts and goes no further.

- d. Pull the quick connector straight out from the fuel tube.

CAUTION:

- Pull quick connector holding it at the "A" position, as shown.
- Do not pull with lateral force applied. O-ring inside quick connector may be damaged.
- Prepare container and cloth beforehand as fuel will leak out.
- Avoid fire and sparks.
- Be sure to cover openings of disconnected pipes with plug or plastic bag to avoid fuel leakage and entry of foreign materials.

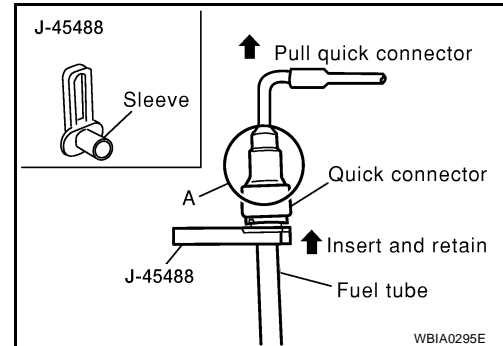

4. Remove the fuel rail with the fuel injectors attached, from the intake manifold. Remove the fuel injector O-rings and use new O-rings for installation.
 5. If necessary, remove fuel damper bolts and the fuel dampers. Remove fuel damper O-rings and use new O-rings for installation.

INSTALLATION

1. If necessary, install fuel dampers and fuel damper bolts. Use new O-rings for installation.
 2. Install the fuel rails with fuel injectors attached.

NOTE:

- Carefully install O-ring.
- Lubricate O-rings by lightly coating with new engine oil.
- Be careful not to damage the O-rings and surfaces for O-ring sealing surfaces. Do not expand or twist O-rings.
- Discard old clips; replace with new ones.
- Make sure that protrusions of fuel injectors are aligned with cutouts of clips after installation.
- Position clips in grooves on the fuel injectors.
- Align the protrusions of the fuel tube assembly with those of the fuel injectors.
- After properly inserting the fuel injectors onto the fuel tube assembly, check that the fuel tube protrusions are engaged with those of fuel injectors, and the flanges of the fuel tube assembly are fully engaged with the clips.

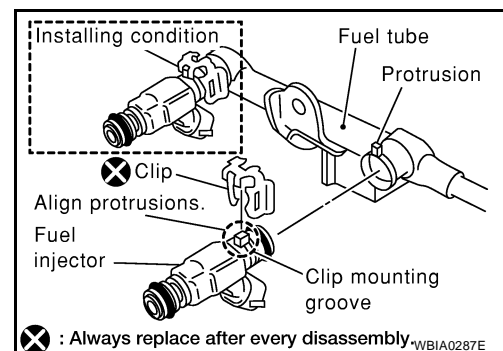

FUEL INJECTOR AND FUEL TUBE

3. Tighten fuel tube assembly bolts in the order as shown, in two steps:

Fuel tube assembly bolts

Step 1 : 10.1 N·m (1.0 kg-m, 89 in-lb)

Step 2 : 22.0 N·m (2.2 kg-m, 16 ft-lb)

CAUTION:

- After properly connecting fuel tube assembly to injector and fuel hose, check connection for fuel leakage.

4. Install the quick connector as follows:
 - a. Make sure no foreign substances are deposited in and around the fuel tube and quick connector and that there is no damage.
 - b. Align the center to insert the quick connector straight onto the fuel tube.
 - c. Insert the fuel tube until a click is heard.
 - d. Install the quick connector cap.
5. Installation of the remaining components is in the reverse order of removal.

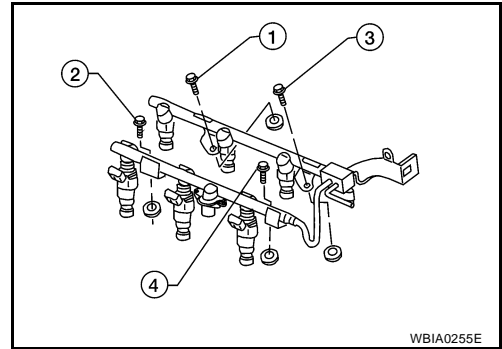

WBIA0255E

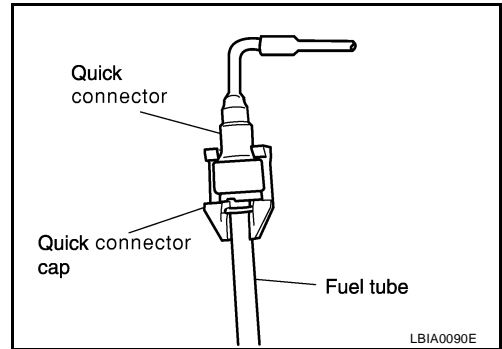

LBIA0090E

INSPECTION AFTER INSTALLATION

Make sure there are no fuel leaks at connections as follows:

1. Apply fuel pressure to fuel lines by turning ignition switch ON (with engine stopped). Then check for fuel leaks at connections.
2. Start the engine and rev it up and check for fuel leaks at connections.

CAUTION:

Do not touch engine immediately after stopping as engine is extremely hot.

NOTE:

Use mirrors for checking on connections out of the direct line of sight.

ROCKER COVER

PFP:13264

EBS00PRR

ROCKER COVER

Removal and Installation

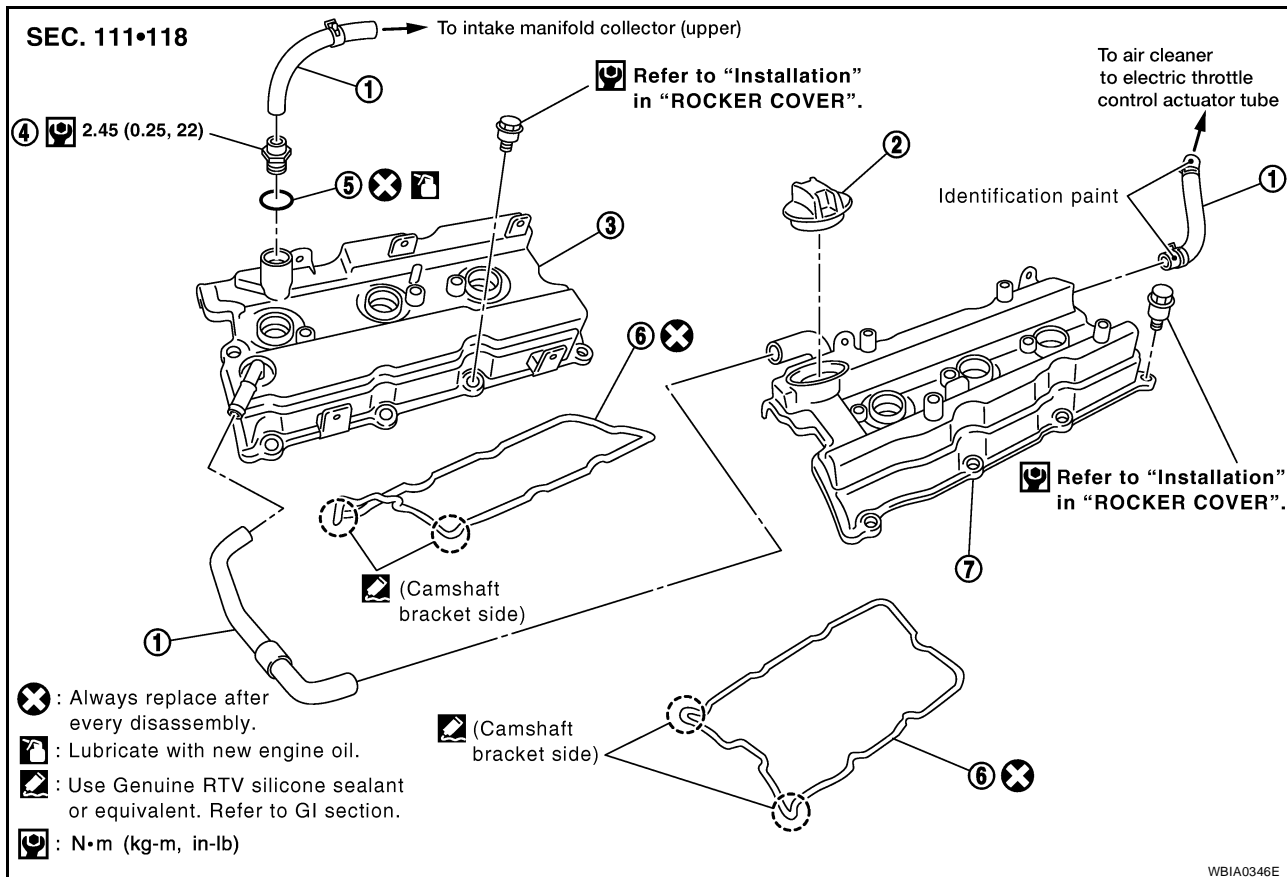

- | | | |
|----------------------|-------------------|------------------------|
| 1. PCV hose | 2. Oil filler cap | 3. Rocker cover (RH) |
| 4. PCV valve | 5. O-ring | 6. Rocker cover gasket |
| 7. Rocker cover (LH) | | |

REMOVAL

1. Remove the engine cover using power tool.
2. If removing rocker cover (RH), disconnect the mass air flow sensor electrical connector and remove the air cleaner to electric throttle control actuator tube and air cleaner lid. Refer to [EM-16, "Removal and Installation"](#).
3. If removing rocker cover (RH), remove the front cowl panel. Refer to [EI-19, "Removal and Installation"](#).
4. If removing rocker cover (RH), remove the windshield wiper arms and motor assembly. Refer to [WW-24, "Wiper Motor and Linkage"](#).
5. If removing rocker cover (RH), remove the intake manifold collector. Refer to [EM-18, "Removal and Installation"](#).
6. If removing rocker cover (LH), disconnect the air fuel ratio (A/F) sensor.
7. Remove the ignition coils. Refer to [EM-36, "Removal and Installation"](#).
8. Position engine harness aside.
9. Disconnect PCV hoses.
10. Remove the engine oil dipstick.
11. Remove rocker covers bolts in the order as shown.

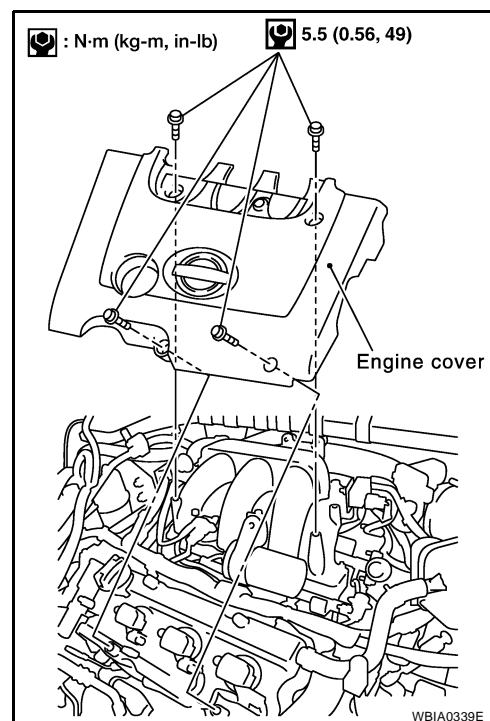

ROCKER COVER

INSTALLATION

Installation is in the reverse order of removal.

- Apply sealant to the areas on the front corners. Refer to [EM-96, "CYLINDER HEAD"](#).
- Use Genuine Silicone RTV Sealant or equivalent. Refer to [GI-46, "RECOMMENDED CHEMICAL PRODUCTS AND SEALANTS"](#).
- Tighten the rocker cover bolts in two steps in the order as shown.

Rocker cover bolts

Step 1 : 1.96 N·m (0.20 kg-m, 17 in-lb)

Step 2 : 8.33 N·m (0.85 kg-m, 74 in-lb)

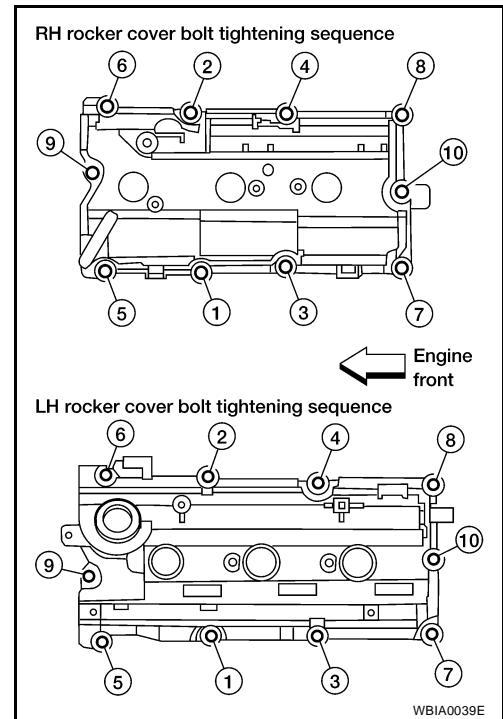

- Install engine cover using power tools.

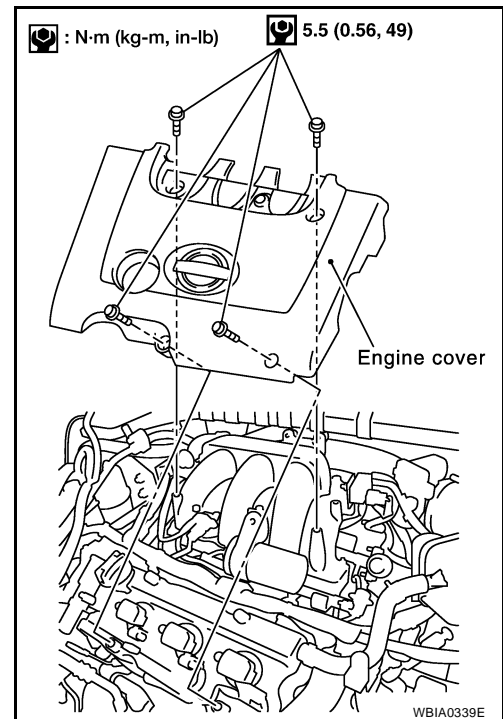

FRONT TIMING CHAIN CASE

FRONT TIMING CHAIN CASE

Removal and Installation

PF1:13599

EBS00PRS

SEC. 120•130•150•210•275

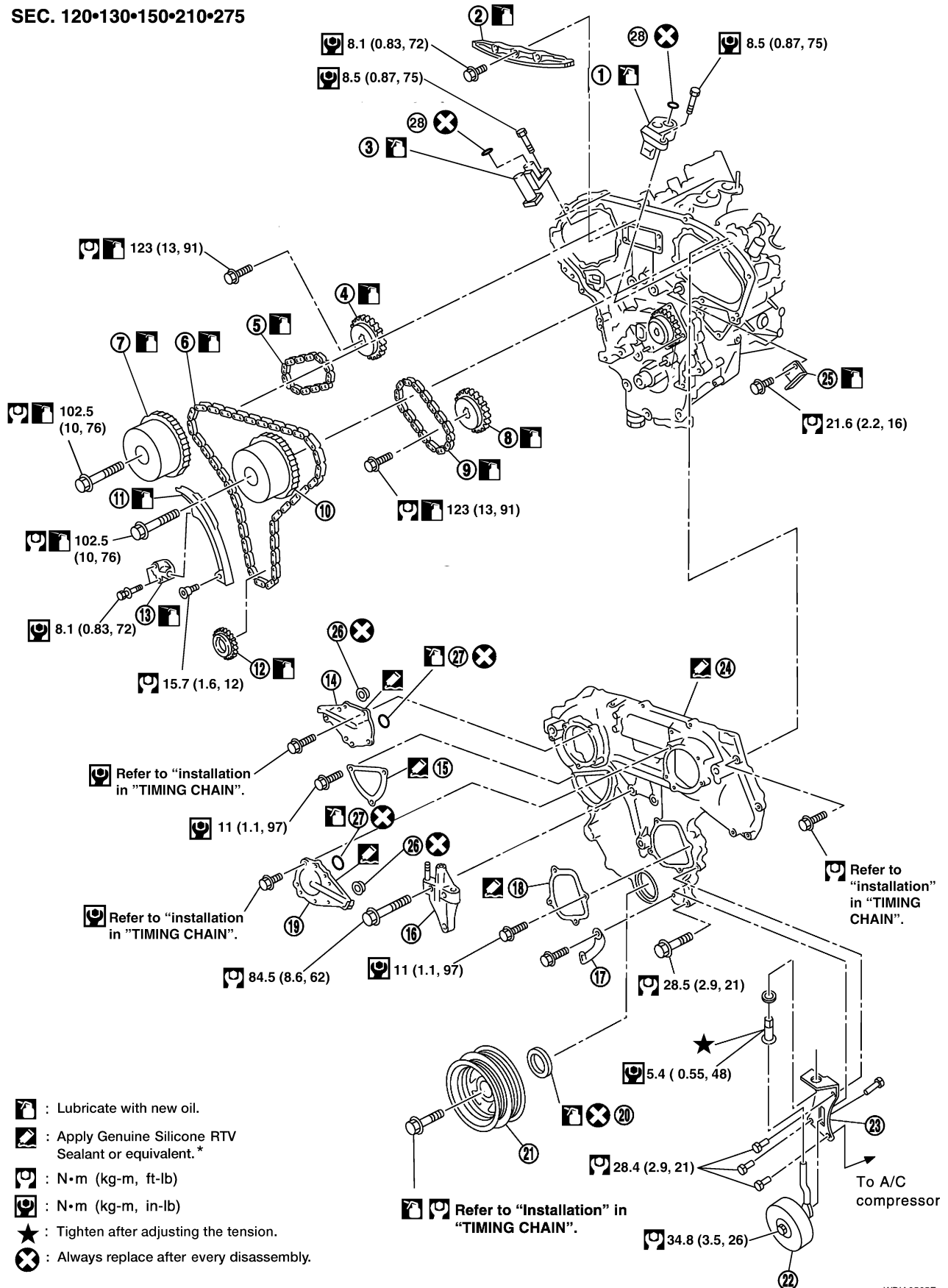

A
EM
C
D
E
F
G
H
I
J
K
L
M

FRONT TIMING CHAIN CASE

- | | | |
|------------------------------------|-------------------------------------|-----------------------------|
| 1. Timing chain tensioner | 2. Internal chain guide | 3. Timing chain tensioner |
| 4. Camshaft sprocket (EXH) | 5. Timing chain (secondary) | 6. Timing chain (primary) |
| 7. Camshaft sprocket (INT) | 8. Camshaft sprocket (EXH) | 9. Timing chain (secondary) |
| 10. Camshaft sprocket (INT) | 11. Slack guide | 12. Crankshaft sprocket |
| 13. Timing chain tensioner | 14. IVT control valve cover - right | 15. Chain tensioner cover |
| 16. RH engine mounting bracket | 17. Water hose clamp | 18. Water pump cover |
| 19. IVT control valve cover - left | 20. Front oil seal | 21. Crankshaft pulley |
| 22. Idler pulley | 23. Idler pulley bracket | 24. Front timing chain case |
| 25. Timing chain tension guide | 26. Collared O-ring | 27. Seal ring |
| 28. O-ring | | |

NOTE:

- This section describes procedures for removal/installation procedure of the front timing chain case and timing chain related parts without removing the upper oil pan from the vehicle.
- When upper oil pan needs to be removed or installed, or when rear timing chain case is removed or installed, remove upper and lower oil pans first. Then remove front timing chain case, timing chain related parts, and rear timing chain case in this order, and install in reverse order of removal. Refer to [EM-56, "TIMING CHAIN"](#).
- Refer to [EM-56, "TIMING CHAIN"](#) for component parts location.

REMOVAL

1. Disconnect the battery negative terminal.
2. Drain the engine cooling system. Refer to [CO-10, "DRAINING ENGINE COOLANT"](#).
3. Drain engine oil. Refer to [LU-9, "Changing Engine Oil"](#).
4. Remove engine cover using power tool.
5. Remove the upper air cleaner case, mass air flow sensor and air cleaner to electric throttle control actuator tube. Refer to [EM-16, "REMOVAL"](#).
6. Remove the engine coolant reservoir tank. Refer to [CO-15, "Removal and Installation"](#).

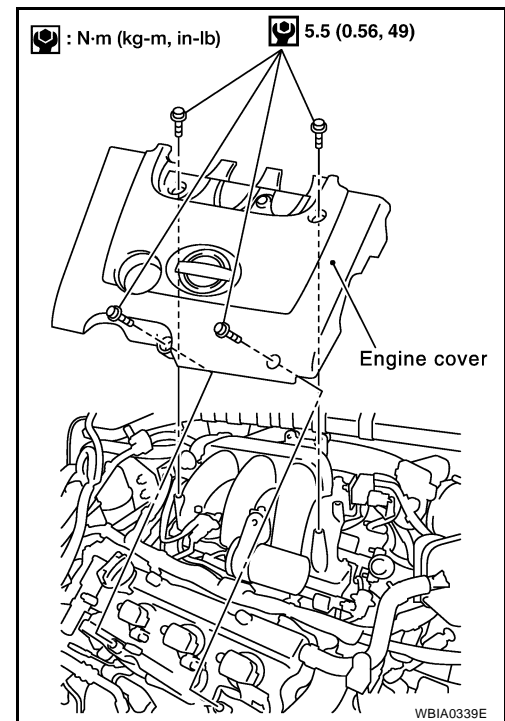

7. Remove the cowl top and cowl top extension. Refer to [EI-19, "Removal and Installation"](#).
8. Remove the IPDM E/R and position aside. Remove the bracket. Refer to [PG-33, "Removal and Installation of IPDM E/R"](#).
9. Remove the front RH wheel and tire using power tool. Refer to [WT-7, "ROAD WHEEL TIRE ASSEMBLY"](#).
10. Remove the engine undercover.
11. Remove the RH inner fender splash shield.
12. Remove the drive belts and idler pulley. Refer to [EM-15, "REMOVAL"](#).

FRONT TIMING CHAIN CASE

13. Recover the A/C refrigerant and remove the A/C compressor. Refer to [ATC-193, "Evacuating System and Charging Refrigerant"](#) .
14. Remove engine oil cooler pipe bolts.
15. Remove the power steering oil pump and reservoir tank with lines attached and position them aside. Refer to [PS-22, "Removal and Installation"](#) .
16. Remove the lower oil pan. Refer to [EM-30, "REMOVAL"](#) .
17. Remove the generator. Refer to [SC-26, "REMOVAL"](#) .
18. Disconnect the engine harness and position aside.
19. Remove the A/C low-pressure flexible hose. Refer to [ATC-201, "Removal and Installation for Low-pressure Flexible Hose"](#) (ATC) or [MTC-180, "Removal and Installation for Low-pressure Flexible Hose"](#) (MTC).
20. Support the engine and remove the RH engine mounting insulator, mount and bracket. Refer to [EM-112, "Removal and Installation"](#) .

21. Remove the chain tensioner cover and water pump cover using plastic hammer to tap (1) and slide (2) Tool.

Tool number : KV1011100 (J-37228)

CAUTION:
Be careful not to damage mating surface.

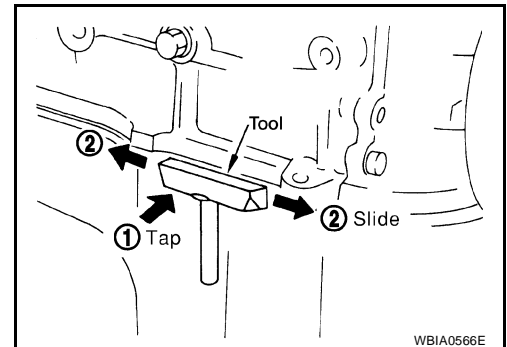
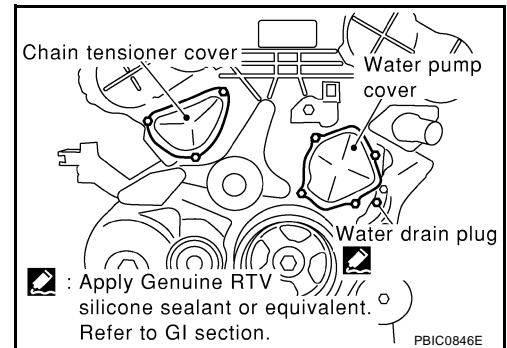

22. Loosen the IVT control cover bolts in the order as shown and remove the IVT control covers.

NOTE:

The shaft in the cover is inserted into the center hole of the intake camshaft sprocket. Remove the cover by pulling straight out until the cover disengages from the camshaft sprocket.

23. Remove the starter motor. Refer to [SC-16, "REMOVAL"](#) .
24. Remove the upper and lower intake manifold collectors. Refer to [EM-19, "REMOVAL"](#) .

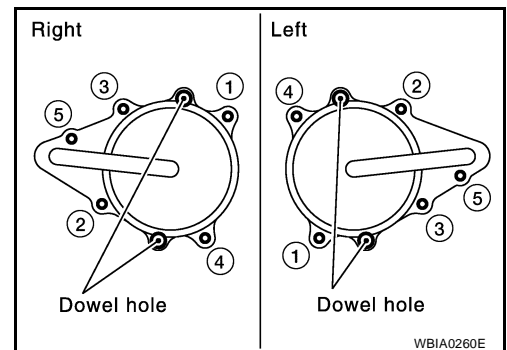

FRONT TIMING CHAIN CASE

- 25. Remove the six ignition coils.
- 26. Remove the engine oil dipstick.

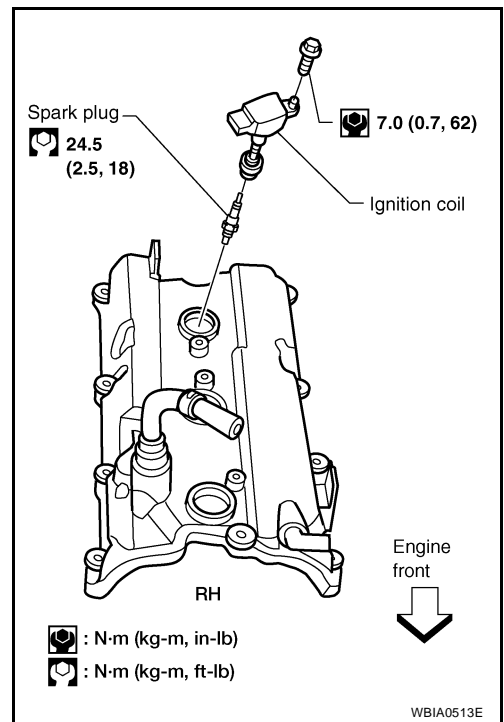

- 27. If necessary, remove the rocker covers. Loosen the rocker covers bolts in the order as shown.

NOTE:

Necessary only when removing secondary timing chains.

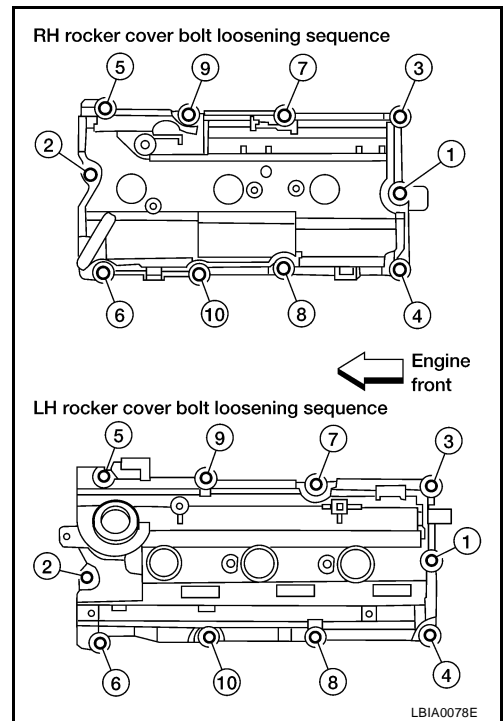

- 28. Remove the IVT control solenoid valves.
 - Discard the gaskets and use new gaskets for installation.

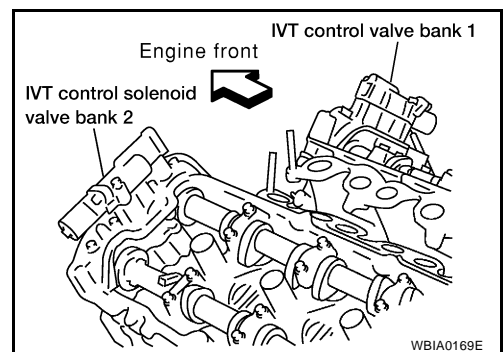

FRONT TIMING CHAIN CASE

29. Obtain compression TDC of No. 1 cylinder as follows:

- Rotate crankshaft pulley clockwise to align timing mark (grooved line without color) with timing indicator.

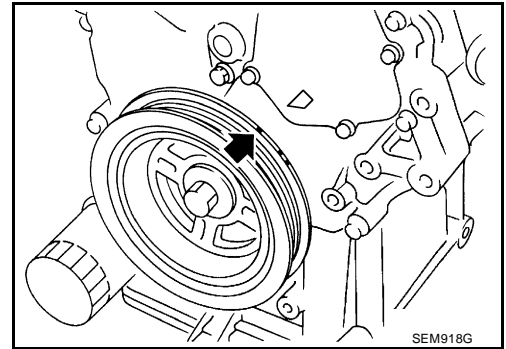

- Check that intake and exhaust camshaft lobes on No. 1 cylinder (right bank of engine) are located as shown.

- If not, turn the crankshaft one revolution (360°) and align as shown.

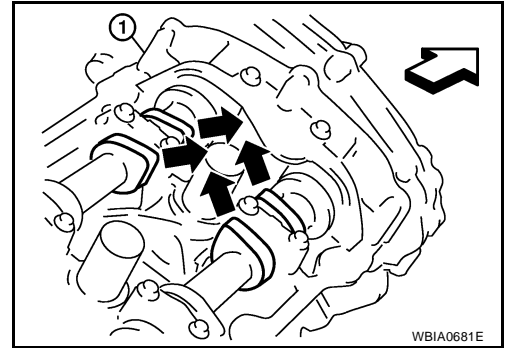

30. Lock the ring gear using Tool attached to the starter bolt hole.

Tool number : KV10117700 (J-44716)

CAUTION:

Do not damage the ring gear teeth, or the signal plate teeth behind the ring gear, when setting the Tool.

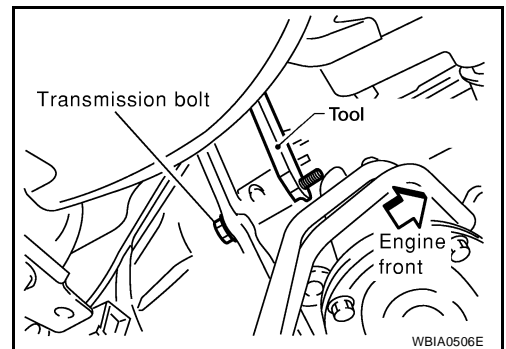

31. Remove the crankshaft pulley as follows:

- Loosen crankshaft pulley bolt and locate bolt seating surface at 10 mm (0.39 in) from its original position.
- Position a pulley puller at recess hole of crankshaft pulley to remove crankshaft pulley.

CAUTION:

Do not use a puller claw on crankshaft pulley periphery.

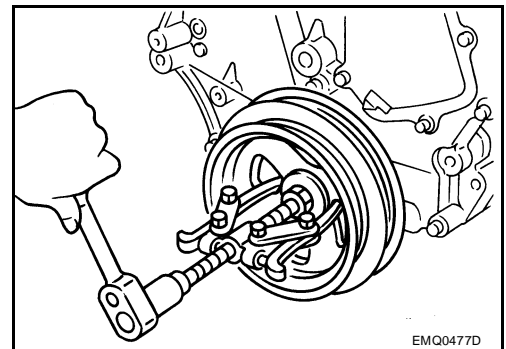

FRONT TIMING CHAIN CASE

32. Loosen the lower oil pan bolts in the order as shown. Remove the lower oil pan.

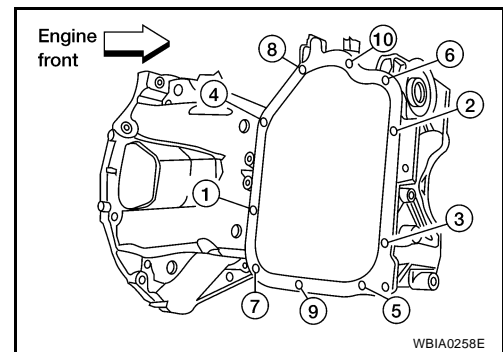

33. Remove the lower oil pan.
 a. Insert Tool between the lower oil pan and the upper oil pan.

Tool number : KV10111100 (J-37228)

- Be careful not to damage the mating surface.
 - Do not insert a screwdriver, this will damage the mating surfaces.
- b. Use the Tool by tapping (1) and sliding (2) using a plastic hammer to remove the lower oil pan from the upper oil pan.

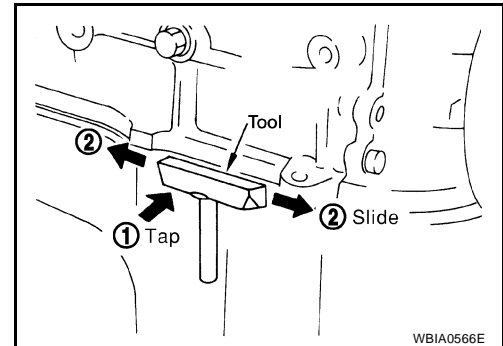

34. Loosen upper oil pan front bolts in the order as shown.

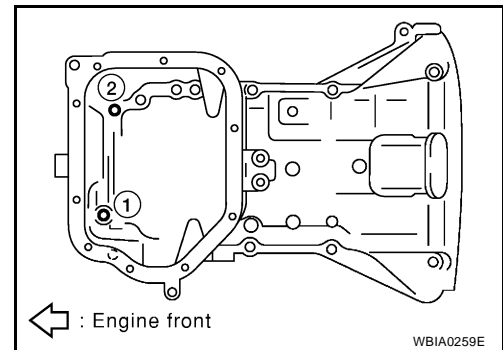

35. Temporarily install lower oil pan.
 36. Support front of engine under oil pan using a jack.
 37. Remove the front timing chain case.
 a. Loosen the front timing chain case bolts in the order as shown.

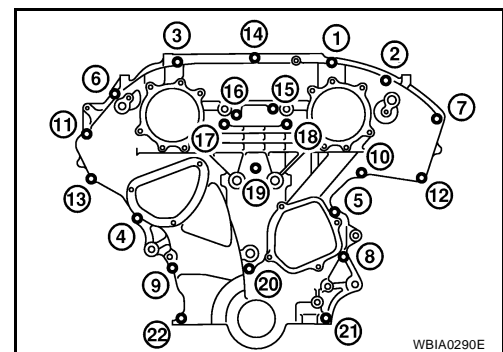

FRONT TIMING CHAIN CASE

- b. Insert the suitable tool into the notch (1) at the top of the front timing chain case to pry (2) it loose as shown.

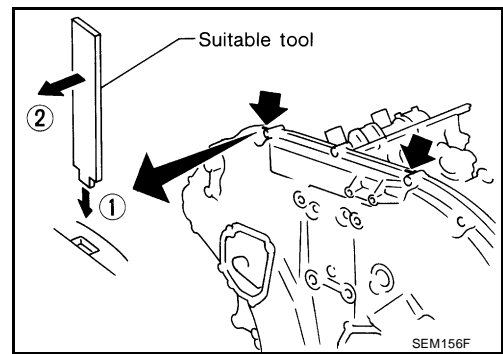

- c. Use the Tool by tapping (1) and sliding (2) using a plastic hammer to remove the lower oil pan from the upper oil pan.

Tool number : KV10111100 (J-37228)

CAUTION:

- Do not use a screwdriver or similar tool.
- After removal, handle carefully so it does not bend, or warp under a load.

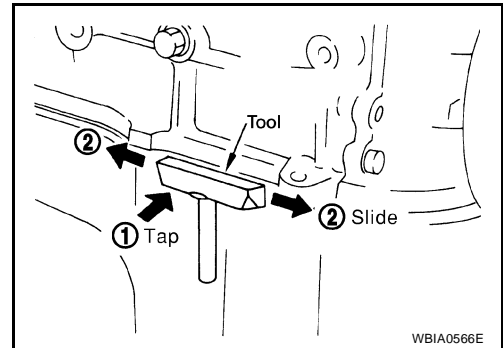

38. Remove the water pump cover and chain tensioner cover from the front timing chain case using Tool.

Tool number : KV10111100 (J-37228)

CAUTION:

- Be careful not to damage the mating surface.
- Do not insert a screwdriver, this will damage the mating surfaces.

39. Remove the front oil seal from the front timing chain case using a suitable tool.

CAUTION:

Do not damage the front cover.

40. Remove timing chain and related parts if necessary. Refer to [EM-57, "REMOVAL"](#).

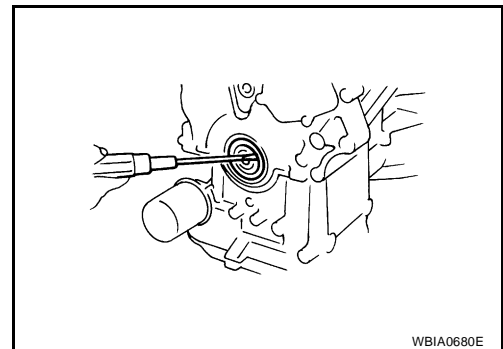

41. Remove O-rings and seal rings from front and rear timing chain case.

42. Use a scraper to remove all of the old Silicone RTV Sealant from the front timing chain case and opposite mating surfaces.

CAUTION:

Do not damage the mating surfaces.

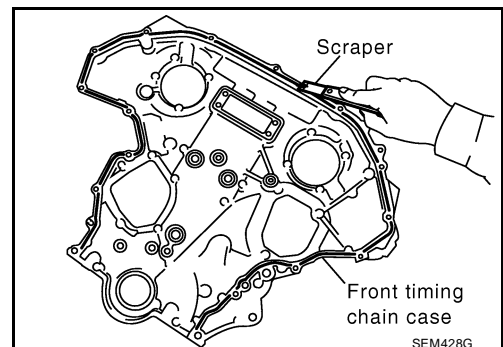

INSTALLATION

1. Install timing chain and related parts. Refer to [EM-57, "REMOVAL"](#).

FRONT TIMING CHAIN CASE

2. Install dowel pins (right and left) into front timing chain case up to a point close to taper in order to shorten protrusion length using suitable tool.

NOTE:

If removed during disassembly make sure dowel pins are installed correctly to insure proper assembly.

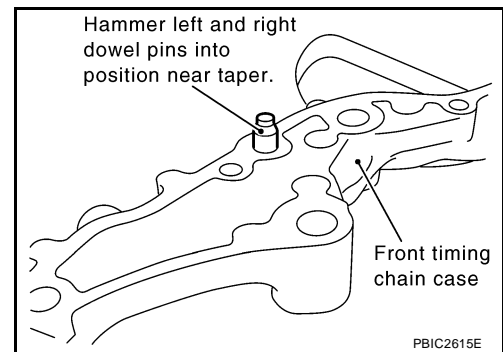

3. Apply new engine oil to new oil seal and install it flush with front of mounting surface using a suitable tool.

- Install new oil seal in the direction as shown.

Suitable drift

Outer diameter : 59 mm (2.32 in)

Inner diameter : 49 mm (1.93 in)

CAUTION:

Press fit straight and avoid causing burrs or tilting the oil seal.

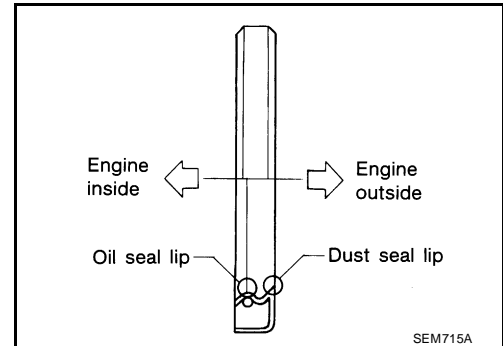

4. Apply Silicone RTV Sealant to front timing chain case as shown.

- Use Genuine Silicone RTV Sealant, or equivalent. Refer to [MA-9. "Fluids and Lubricants"](#).
- Before installation, wipe off the protruding sealant.
- Install dowel pin on the rear timing chain case into dowel pin hole in front timing chain case.

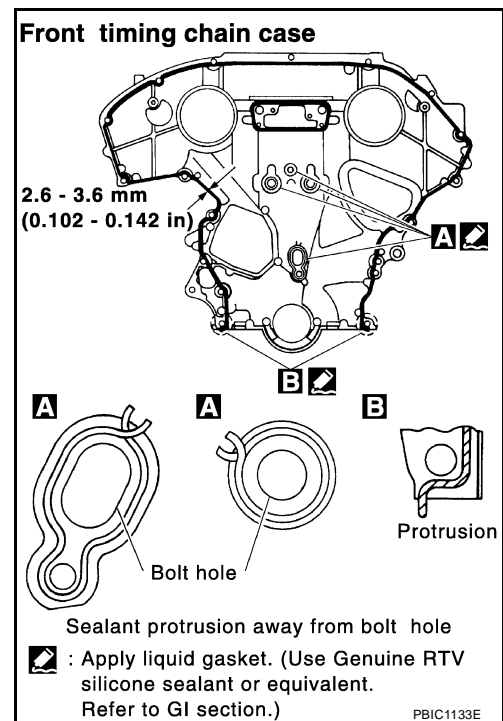

FRONT TIMING CHAIN CASE

5. Apply Silicone RTV Sealant to top surface of oil pan (upper) as shown.
- Use Genuine Silicone RTV Sealant, or equivalent. Refer to [MA-9, "RECOMMENDED FLUIDS AND LUBRICANTS"](#).

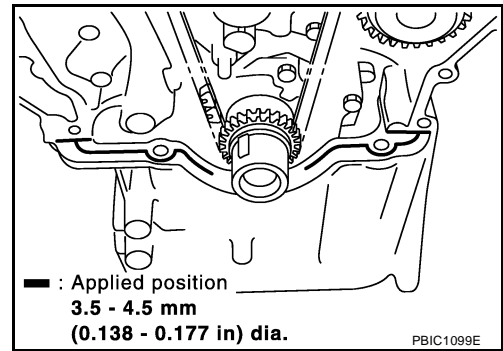

6. Install front timing chain case.
- a. Install lower end of front timing chain case tightly onto top surface of oil pan (upper).

CAUTION:

Be careful that oil pan gasket is in place.

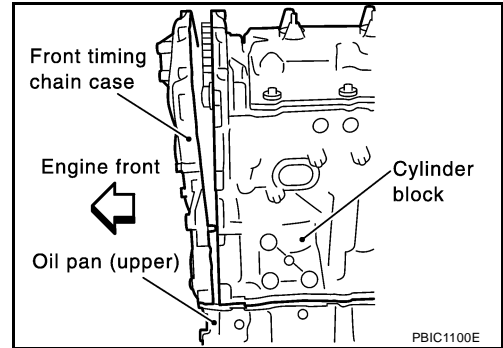

- b. While pressing front timing chain case from its front and top as shown, hammer dowel pin until the outer end becomes flush with surface using suitable tool.
- Install dowel pin on the rear timing chain case into dowel pin hole in front timing chain case.

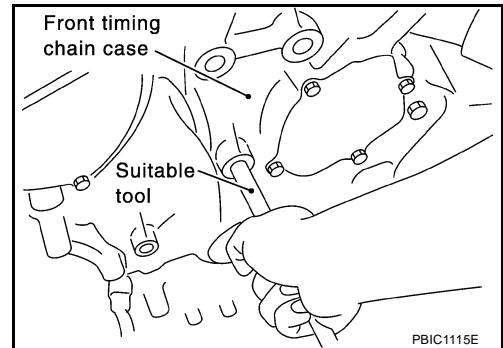

7. Loosely install the front timing chain case bolts.

Bolt position	Bolt diameter
1, 2	: 8 mm (0.31 in)
3 - 22	: 6 mm (0.24 in)

8. Tighten the front timing chain case bolts in the order as shown.
- Retighten the front timing chain case bolts in the order as shown.

Bolt position	Tightening specification
1, 2	: 28.5 N·m (2.9 kg-m, 21 ft-lb)
3 - 22	: 12.8 N·m (1.3 kg-m, 9 ft-lb)

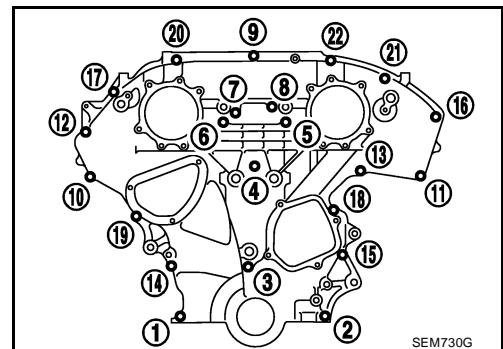

FRONT TIMING CHAIN CASE

9. Install the upper oil pan front bolts in the order as shown.

Upper oil pan front bolts : 17.2 N-m (1.8 kg-m, 13 ft-lb)

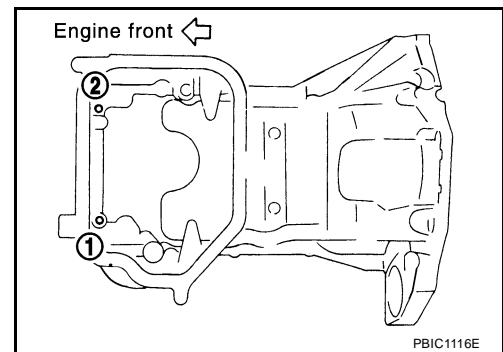

10. Install IVT control valve covers as follows:

a. Install new collared O-rings in front cover oil hole (LH and RH sides).

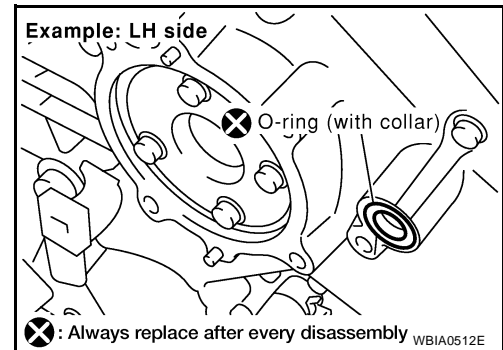

b. Install new seal rings on the IVT control covers.

c. Apply Silicone RTV Sealant to the IVT control covers.

- Use Genuine Silicone RTV Sealant, or equivalent. Refer to [GI-46, "RECOMMENDED CHEMICAL PRODUCTS AND SEALANTS"](#).

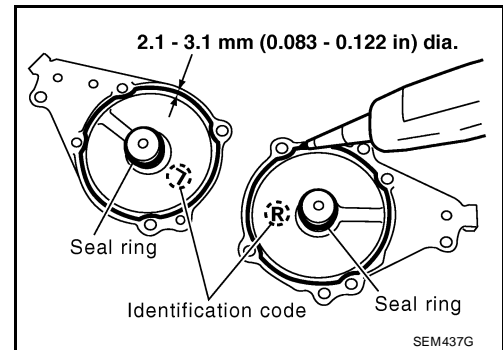

- Being careful not to move the seal ring from the installation groove, align the dowel pins on the chain case with the holes to install the IVT control covers.
- Tighten the intake valve timing control cover bolts in the order as shown.

Intake valve timing control cover bolts : 11.3 N-m (1.2 kg-m, 100 in-lb)

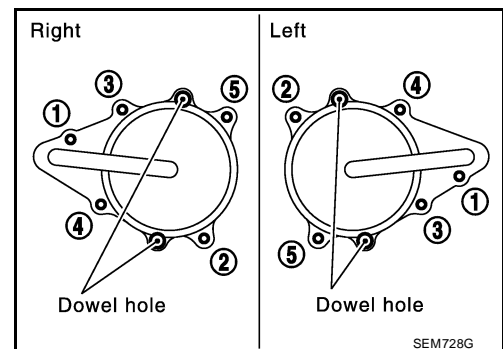

11. Apply liquid gasket and install the water pump cover and the chain tensioner cover.

Water pump cover bolts : 11 N-m (1.1 kg-m, 97 in-lb)

Chain tensioner cover bolts : 11 N-m (1.1 kg-m, 97 in-lb)

- Use Genuine Silicone RTV Sealant or equivalent. Refer to [GI-46, "RECOMMENDED CHEMICAL PRODUCTS AND SEALANTS"](#).

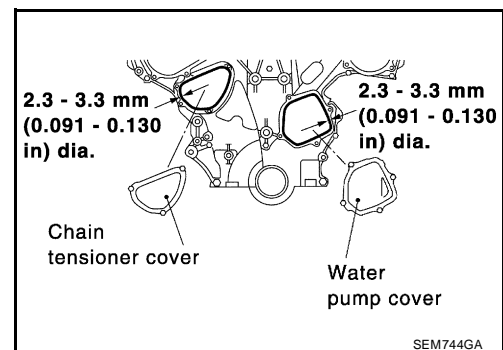

FRONT TIMING CHAIN CASE

12. Install crankshaft pulley and tighten the bolt in two steps.
- Lubricate thread and seat surface of the bolt with new engine oil.
 - For the second step of angle tightening. Using Tool.

Step 1 : 44 N·m (4.5 kg·m, 32 ft·lb)

Step 2 : 84° - 90° degrees clockwise

Tool number : KV10112100 (BT-8653-A)

13. Remove Tool.

Tool number : KV10117700 (J-44716)

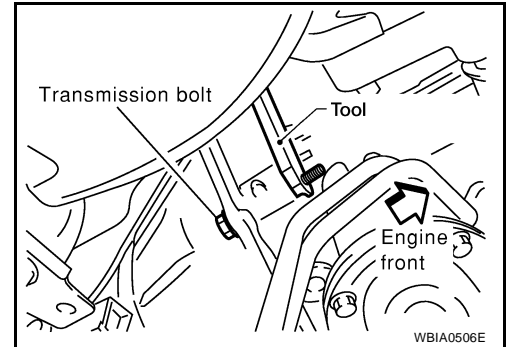

14. Rotate crankshaft pulley in normal direction (clockwise when viewed from front) to confirm it turns smoothly.
15. Installation of the remaining components is in reverse order of removal.

INSPECTION AFTER INSTALLATION

Inspection for Leaks

The following are procedures for checking fluid leaks, lubricant leaks and exhaust gases leaks.

- Before starting engine, check oil/fluid levels including engine coolant and engine oil. If less than required quantity, fill to the specified level. Refer to [MA-9, "Fluids and Lubricants"](#).
- Use procedure below to check for fuel leakage.
- Turn ignition switch "ON" (with engine stopped). With fuel pressure applied to fuel piping, check for fuel leakage at connection points.
- Start engine. With engine speed increased, check again for fuel leakage at connection points.
- Run engine to check for unusual noise and vibration.

NOTE:

If hydraulic pressure inside timing chain tensioner drops after removal/installation, slack in the guide may generate a pounding noise during and just after engine start. However, this is normal. Noise will stop after hydraulic pressure rises.

- Warm up engine thoroughly to make sure there is no leakage of fuel, exhaust gases, or any oil/fluids including engine oil and engine coolant.
- Bleed air from lines and hoses of applicable lines, such as in cooling system.
- After cooling down engine, again check oil/fluid levels including engine oil and engine coolant. Refill to the specified level, if necessary.

Summary of the inspection items:

Item	Before starting engine	Engine running	After engine stopped
Engine coolant	Level	Leakage	Level
Engine oil	Level	Leakage	Level
Other oils and fluid*	Level	Leakage	Level
Fuel	Leakage	Leakage	Leakage

* Transmission/transaxle/CVT fluid, power steering fluid, brake fluid, etc.

TIMING CHAIN

PFP:13028

EBS00PRT

TIMING CHAIN

Removal and Installation

SEC. 120•130•150•210•275

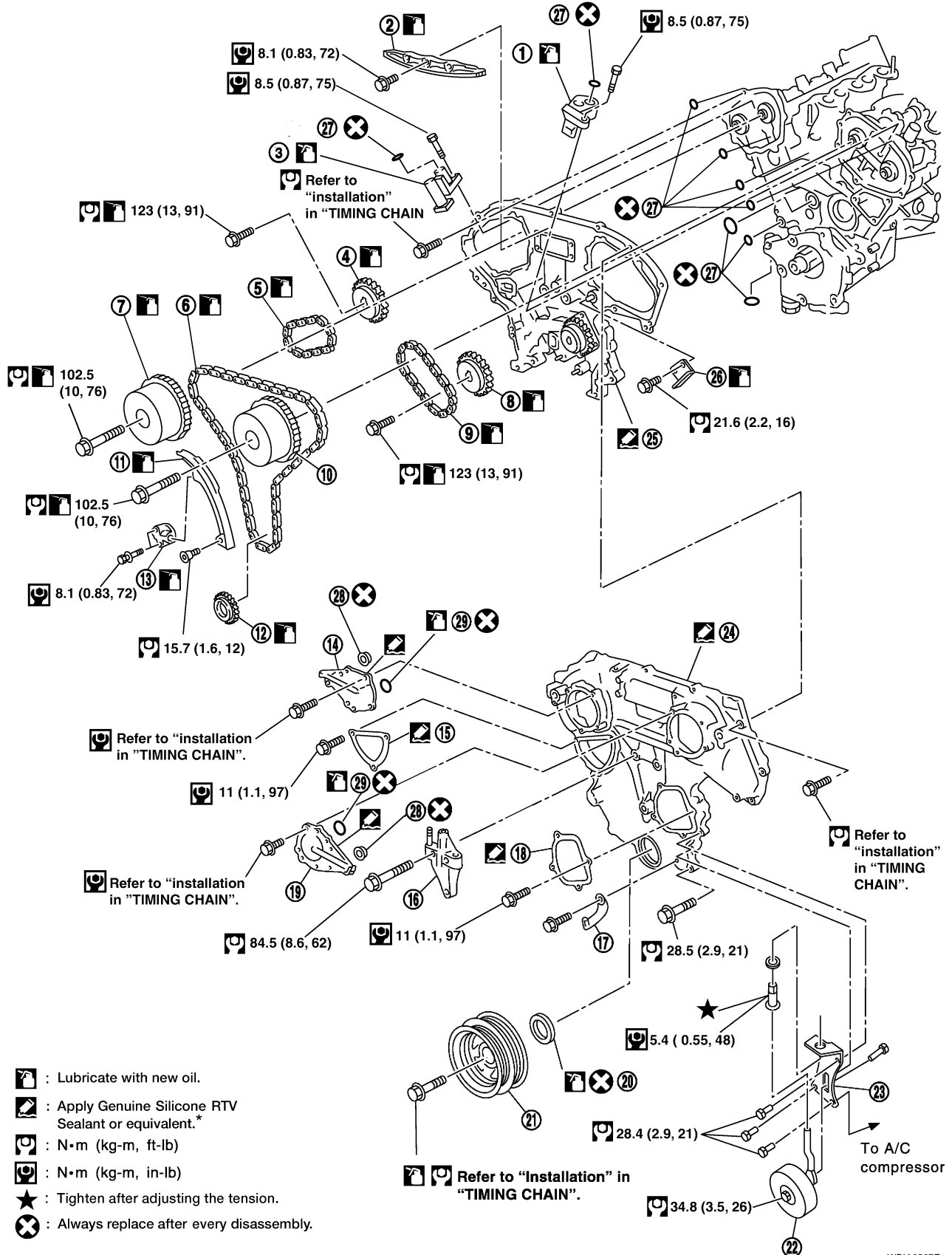

WBIA0507E

TIMING CHAIN

*Refer to [MA-9, "Fluids and Lubricants"](#) .

- | | | |
|------------------------------------|-------------------------------------|-----------------------------|
| 1. Timing chain tensioner | 2. Internal chain guide | 3. Timing chain tensioner |
| 4. Camshaft sprocket (EXH) | 5. Timing chain (secondary) | 6. Timing chain (primary) |
| 7. Camshaft sprocket (INT) | 8. Camshaft sprocket (EXH) | 9. Timing chain (secondary) |
| 10. Camshaft sprocket (INT) | 11. Slack guide | 12. Crankshaft sprocket |
| 13. Timing chain tensioner | 14. IVT control valve cover - right | 15. Chain tensioner cover |
| 16. RH engine mounting bracket | 17. Water hose clamp | 18. Water pump cover |
| 19. IVT control valve cover - left | 20. Front oil seal | 21. Crankshaft pulley |
| 22. Idler pulley | 23. Idler pulley bracket | 24. Front timing chain case |
| 25. Rear timing chain case | 26. Timing chain tension guide | 27. O-ring |
| 28. Collared O-ring | 29. Seal ring | |

CAUTION:

- After removing timing chain, do not turn the crankshaft and camshaft separately, or the valves will strike the pistons.
- When installing camshafts, chain tensioners, oil seals, or other sliding parts, lubricate contacting surfaces with new engine oil.
- Apply new engine oil to bolt threads and seat surfaces when installing camshaft sprockets, camshaft brackets, and crankshaft pulley.
- Before removing the upper oil pan, remove the crankshaft position sensor (POS).
- Be careful not to damage sensor edges.
- Do not spill engine oil or coolant on drive belts.

NOTE:

- This section describes procedures for removal/installation procedure of the front timing chain case and timing chain related parts, and rear timing chain case, when oil pan (upper) needs to be removed/installed for engine overhaul, etc.
- To remove/install front timing chain case, timing chain, and its related parts without removing oil pan (upper), refer to [EM-45, "FRONT TIMING CHAIN CASE"](#) .

REMOVAL

1. Remove the engine assembly from the vehicle. Refer to [EM-113, "REMOVAL"](#) .
2. Install engine slingers.

Engine slinger bolts : 28 N·m (2.9 kg-m, 21 ft-lb)

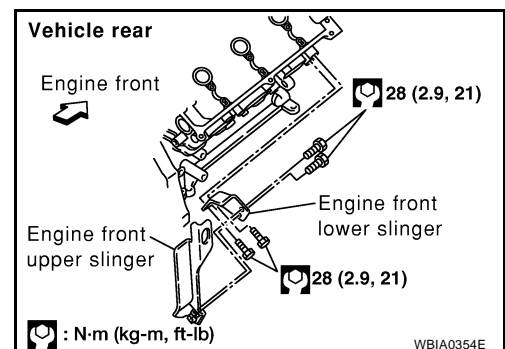
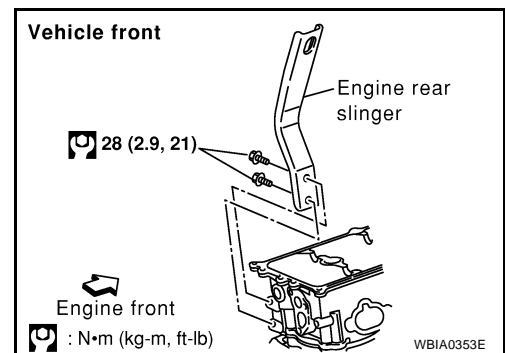

3. Remove idler pulley and bracket.
4. Remove the upper and lower oil pans. Refer to [EM-30, "REMOVAL"](#) .
5. Remove the generator. Refer to [SC-26, "REMOVAL"](#) .

TIMING CHAIN

6. Remove the chain tensioner cover and water pump cover using plastic hammer to tap (1) and slide (2) Tool.

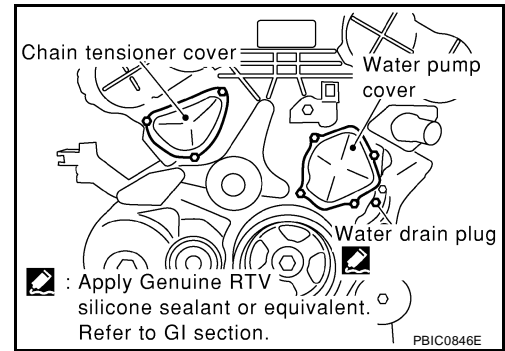

Tool number : KV10111100 (J-37228)

CAUTION:
Be careful not to damage mating surface.

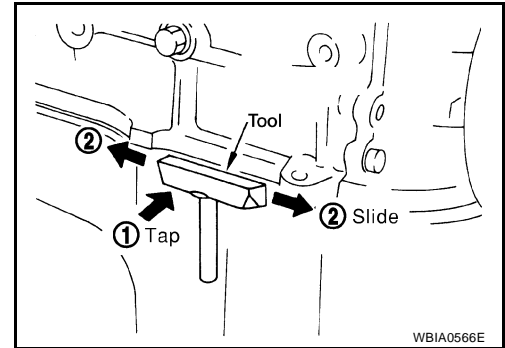

7. Remove the IVT control cover bolts in the order as shown and remove the IVT control covers.

NOTE:

The shaft in the cover is inserted into the center hole of the intake camshaft sprocket. Remove the cover by pulling straight out until the cover disengages from the camshaft sprocket.

8. Remove the starter motor. Refer to [SC-16, "Removal and Installation"](#).
9. Remove the intake manifold collectors (upper and lower). Refer to [EM-19, "REMOVAL"](#).

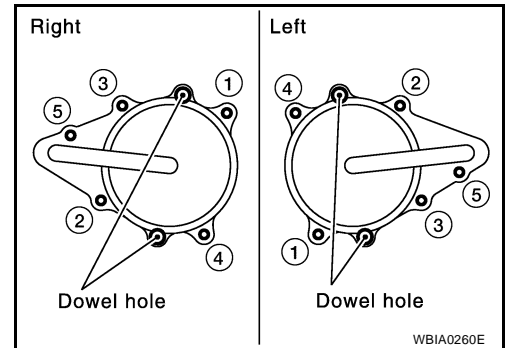

10. Remove the six spark plugs. Refer to [EM-38, "REMOVAL"](#).
11. Remove the rocker covers. Refer to [EM-43, "REMOVAL"](#).
12. Disconnect the connectors and remove the bank 1 and bank 2 IVT control solenoid valves.

- Discard the gaskets and use new gaskets for installation.

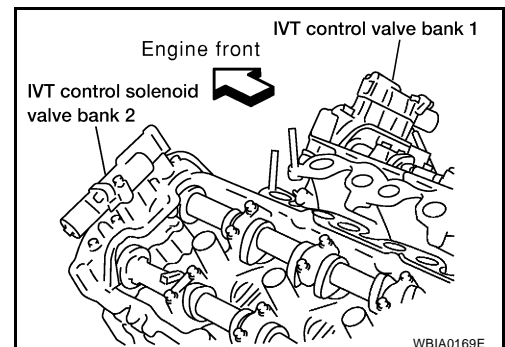

TIMING CHAIN

13. Obtain compression TDC of No. 1 cylinder as follows:

- Rotate crankshaft pulley clockwise to align timing mark (grooved line without color) with timing indicator.

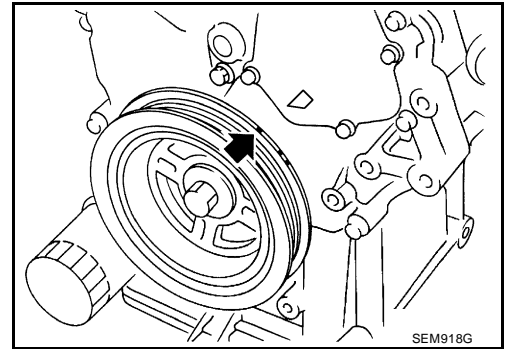

- Check that intake and exhaust camshaft lobes on No. 1 cylinder (right bank of engine) are located as shown.

- If not, turn the crankshaft one revolution (360°) and align as shown.

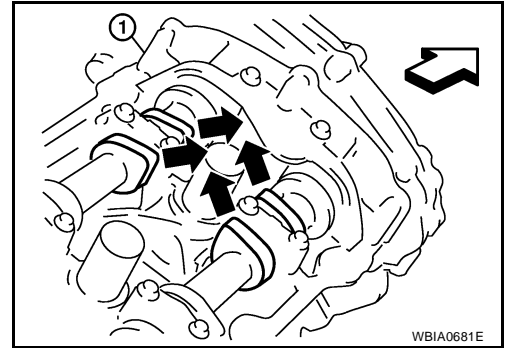

14. Lock the ring gear using Tool attached to the starter bolt hole.

Tool number : KV10117700 (J-44716)

CAUTION:

Do not damage the ring gear teeth, or the signal plate teeth behind the ring gear, when setting the Tool.

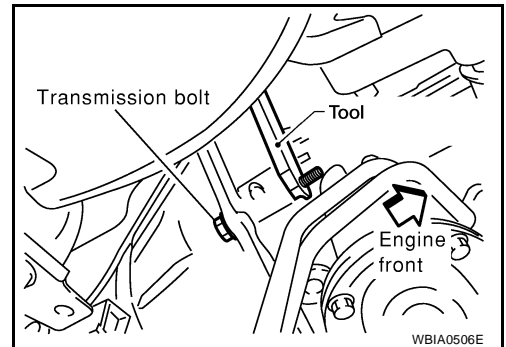

15. Remove the crankshaft pulley as follows:

- Loosen crankshaft pulley bolt and locate bolt seating surface at 10 mm (0.39 in) from its original position.

- Position a pulley puller at recess hole of crankshaft pulley to remove crankshaft pulley.

CAUTION:

Do not use a puller claw on crankshaft pulley periphery.

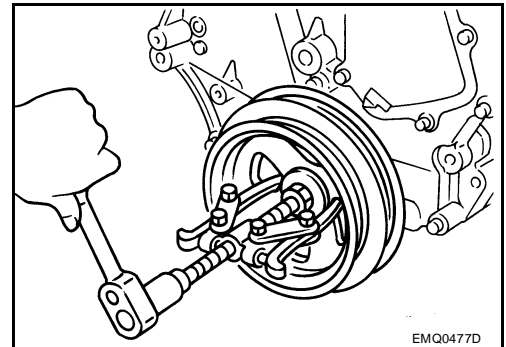

TIMING CHAIN

16. Remove the front timing chain case.

a. Loosen the front timing chain case bolts in the order as shown.

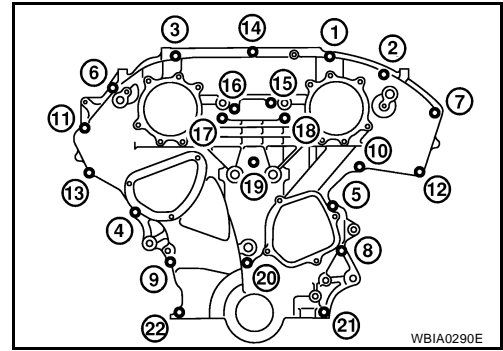

b. Insert the suitable tool into the notch (1) at the top of the front timing chain case to pry (2) it loose as shown.

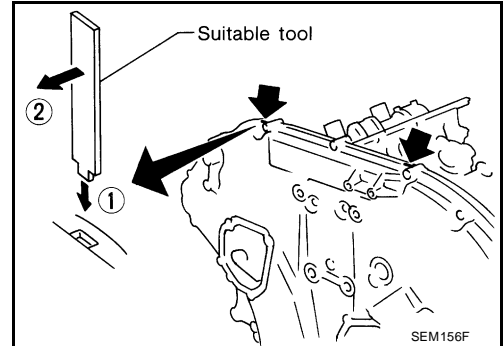

c. Use the Tool by tapping (1) and sliding (2) using a plastic hammer to remove the lower oil pan from the upper oil pan.

Tool number : KV10111100 (J-37228)

CAUTION:

- Do not use a screwdriver or similar tool.
- After removal, handle carefully so it does not bend, or warp under a load.

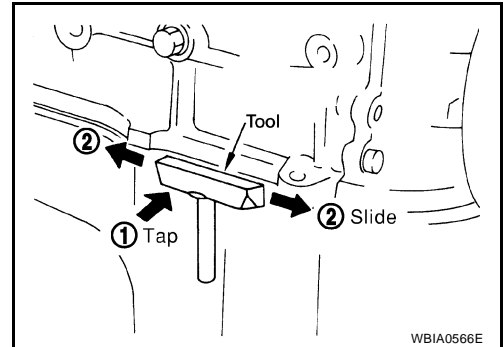

17. Remove the internal chain guide (1).

- Timing chain tensioner (2)
- Timing chain tensioner guide (3)
- Slack guide (4)

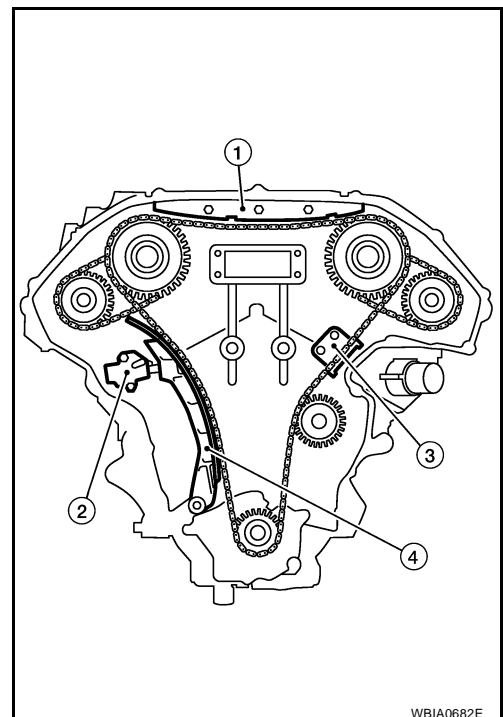

TIMING CHAIN

18. Remove the timing chain tensioner (1) and slack guide (6).
- Place paint marks on the timing chain and sprockets to indicate the correct position of the components for installation.
- a. Pull lever (4) down and release plunger stopper tab (2). Plunger stopper tab (2) can be pushed up to release [coaxial structure with lever (4)].
- ←: pull lever
- b. Insert stopper pin (3) into tensioner body hole to hold lever (4), and keep the tab (2) released. An Allen wrench [2.5 mm (0.098 in)] (3) is used for a stopper pin as an example.
- c. Insert plunger (5) into tensioner body hole by pressing the slack guide (6).
- ←: Press slack guide
- d. Keep the slack guide (6) pressed and hold it by pushing the stopper pin (3) through the lever hole and body hole as shown.
- e. Remove the timing chain tensioner installation bolts (7) and remove the timing chain tensioner (1).
- f. Remove slack guide installation bolt and the slack guide (6).

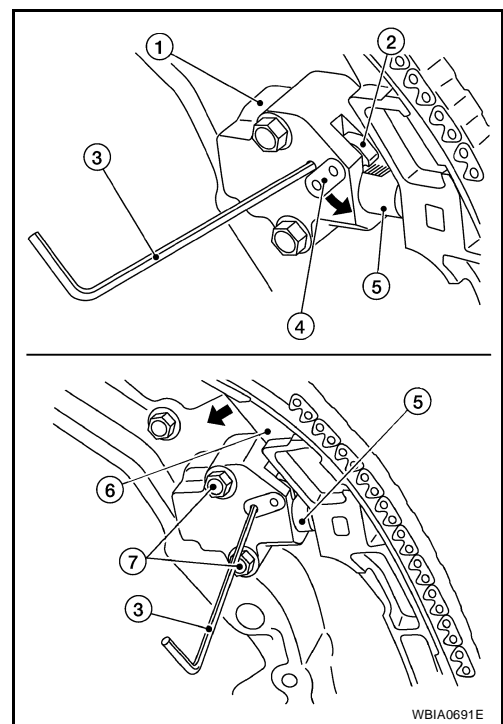

19. Remove primary timing chain and crankshaft sprocket.

CAUTION:

After removing timing chain, do not turn the crankshaft and camshaft separately, or the valves will strike the pistons.

20. Attach a suitable stopper pin (1) to the RH (2) and LH (3) secondary timing chain tensioners.

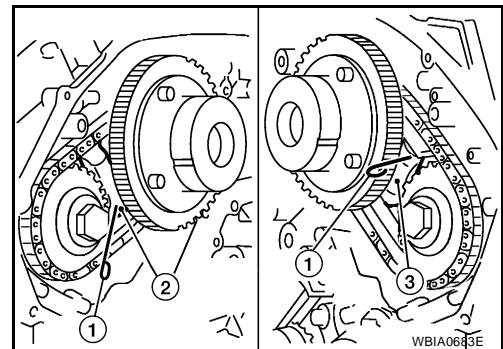

21. Remove the intake and exhaust camshaft sprocket bolts.

- Apply paint to the timing chain and camshaft sprockets for alignment during installation.
- Secure the hexagonal portion of the camshaft using a wrench to loosen the bolts as shown.

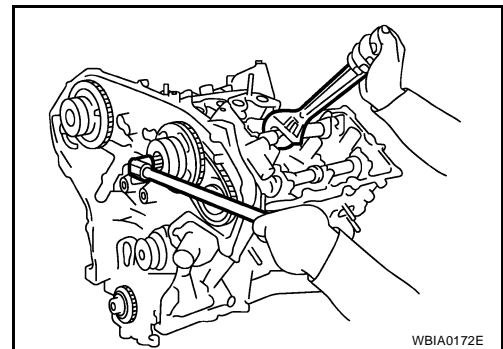

22. Remove the secondary timing chains (3) with camshaft sprockets.

TIMING CHAIN

- Illustration shows RH (1) secondary timing chain (3), refer to side view (7) if needed.
- Rotate camshaft slightly, and loosen secondary timing chain (3) on secondary timing chain tensioner side.
 - Insert metal or resin plate (5) [0.5 mm (0.020 in)] into plunger (6) between secondary timing chain (3) and secondary timing chain tensioner plunger (6). Remove camshaft sprocket and secondary timing chain (3) with secondary timing chain removed from plunger (6) groove.
- Intake camshaft sprocket is two-for-one structure of primary and secondary sprockets.
 - Handle the intake sprockets as an assembly.

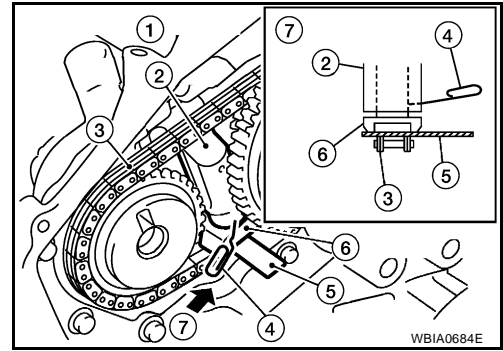

CAUTION:

- Secondary timing chain tensioner plunger (6) can move while stopper pin (4) is inserted in timing chain tensioner (2). Plunger can come out of tensioner when timing chain is removed. Use caution during removal.
- Avoid impact or dropping the intake sprockets.
- Do not disassemble the intake sprockets (never loosen bolts A and B as shown).

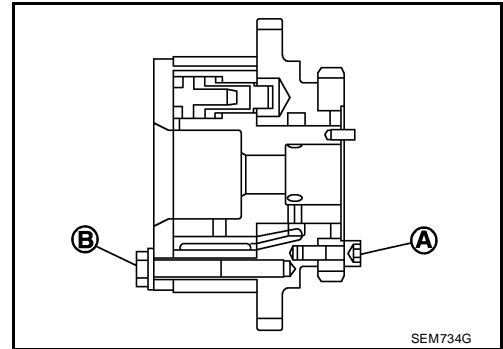

- Loosen the No. 1 camshaft bracket bolts in several steps in the order as shown and remove No. 1 camshaft brackets.

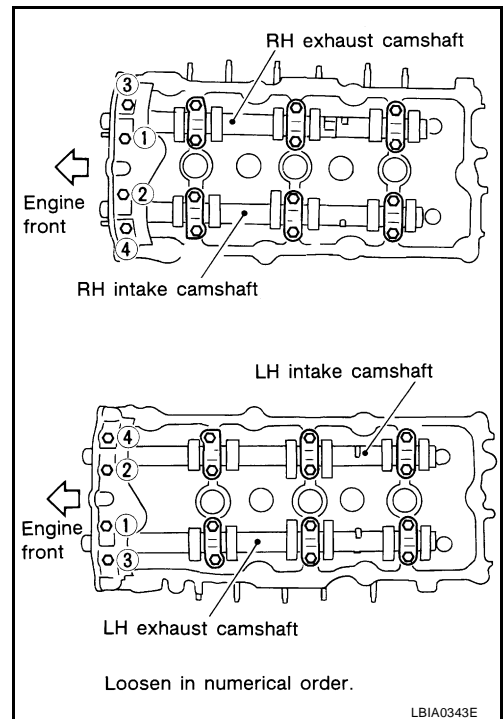

- Remove the timing chain tension guide.

TIMING CHAIN

25. Remove the rear timing chain case.

CAUTION:

- Do not remove the plate metal covers for the oil passage.
- After removing the chain case, do not apply any load to the case that might bend it.

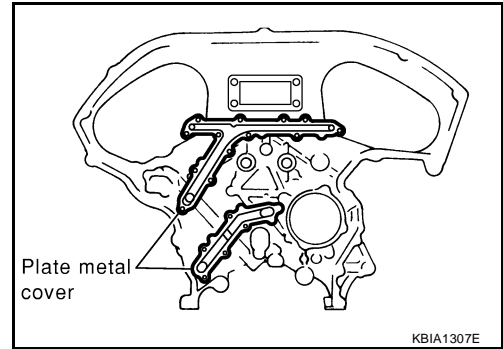

a. Loosen and remove the rear timing chain case bolts in the order as shown.

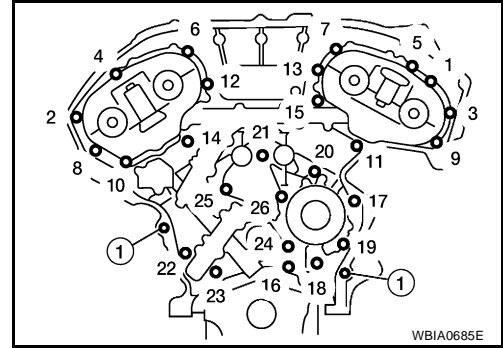

b. Cut the sealant using Tool (A) and remove the rear timing chain case.

Tool number : KV10111100 (J-37228)

CAUTION:

Be careful not to damage mating surface.

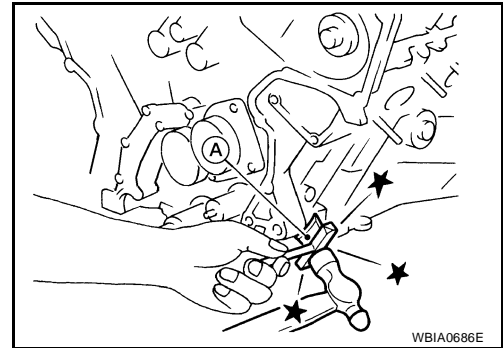

26. Remove the engine coolant inlet and thermostat assembly.

27. Remove O-rings (3) on the RH (1) and LH (2) No. 1 camshaft bracket, cylinder head and cylinder block.

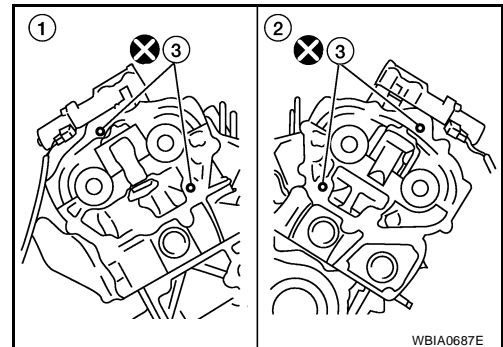

TIMING CHAIN

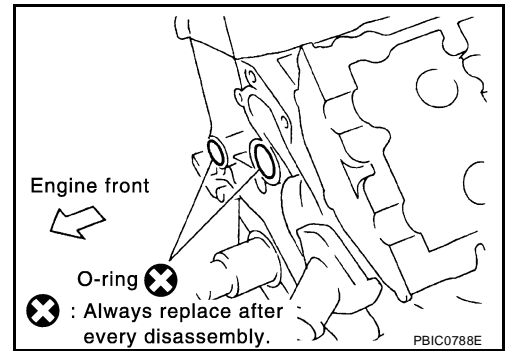

28. If necessary, remove the water pump. Refer to [CO-18](#), "[REMOVAL](#)".

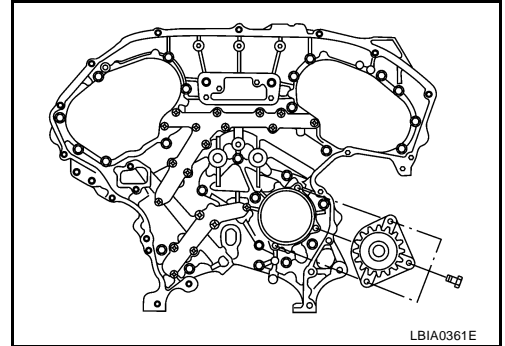

29. Remove the camshaft chain tensioners (for secondary timing chains).

30. Use a scraper to remove all of the old Silicone RTV Sealant from the front and rear timing chain case and opposite mating surfaces.

CAUTION:

Do not damage the mating surfaces.

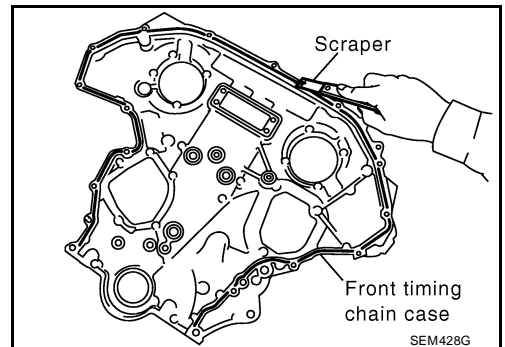

31. Remove all old Silicone RTV Sealant from all the bolt holes and bolts.

CAUTION:

Do not damage the threads or mating surfaces.

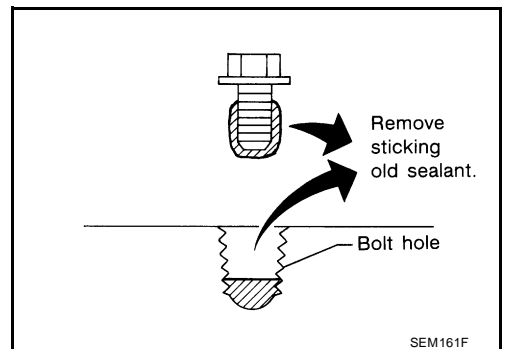

TIMING CHAIN

32. Use a scraper to remove all the old Silicone RTV Sealant from the water pump cover, chain tensioner cover and IVT control covers.

CAUTION:
Do not damage the mating surfaces.

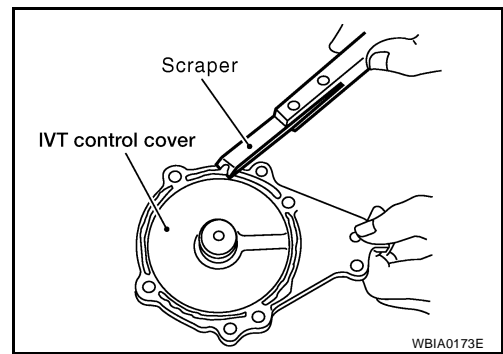

33. Remove the old Silicone RTV Sealant from the camshaft No. 1 bracket mating surface using a scraper.

CAUTION:
Do not scratch or damage the mating surface.

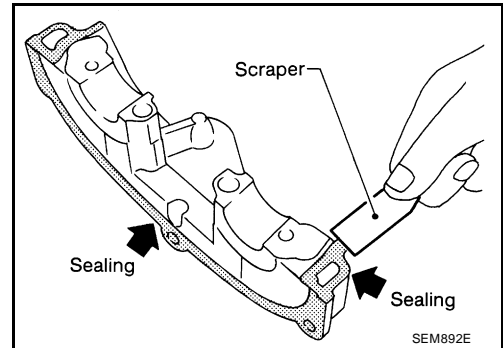

34. Remove the front oil seal from the front timing chain case using a suitable tool.

CAUTION:
Do not damage the front cover.

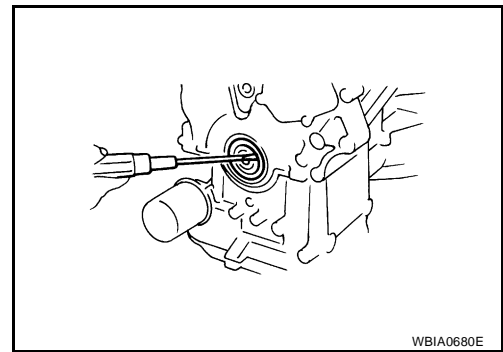

Inspection after removal

Check for cracks and any excessive wear at the roller links of the timing chain. Replace the timing chain as necessary.

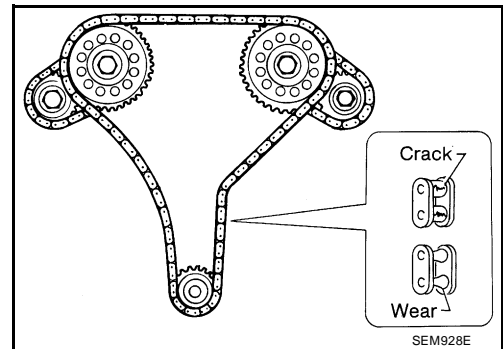

A
EM
C
D
E
F
G
H
I
J
K
L
M

TIMING CHAIN

Installation

NOTE:

The figure shows the relationship between the mating mark on each timing chain and that on the corresponding sprocket, with the components installed.

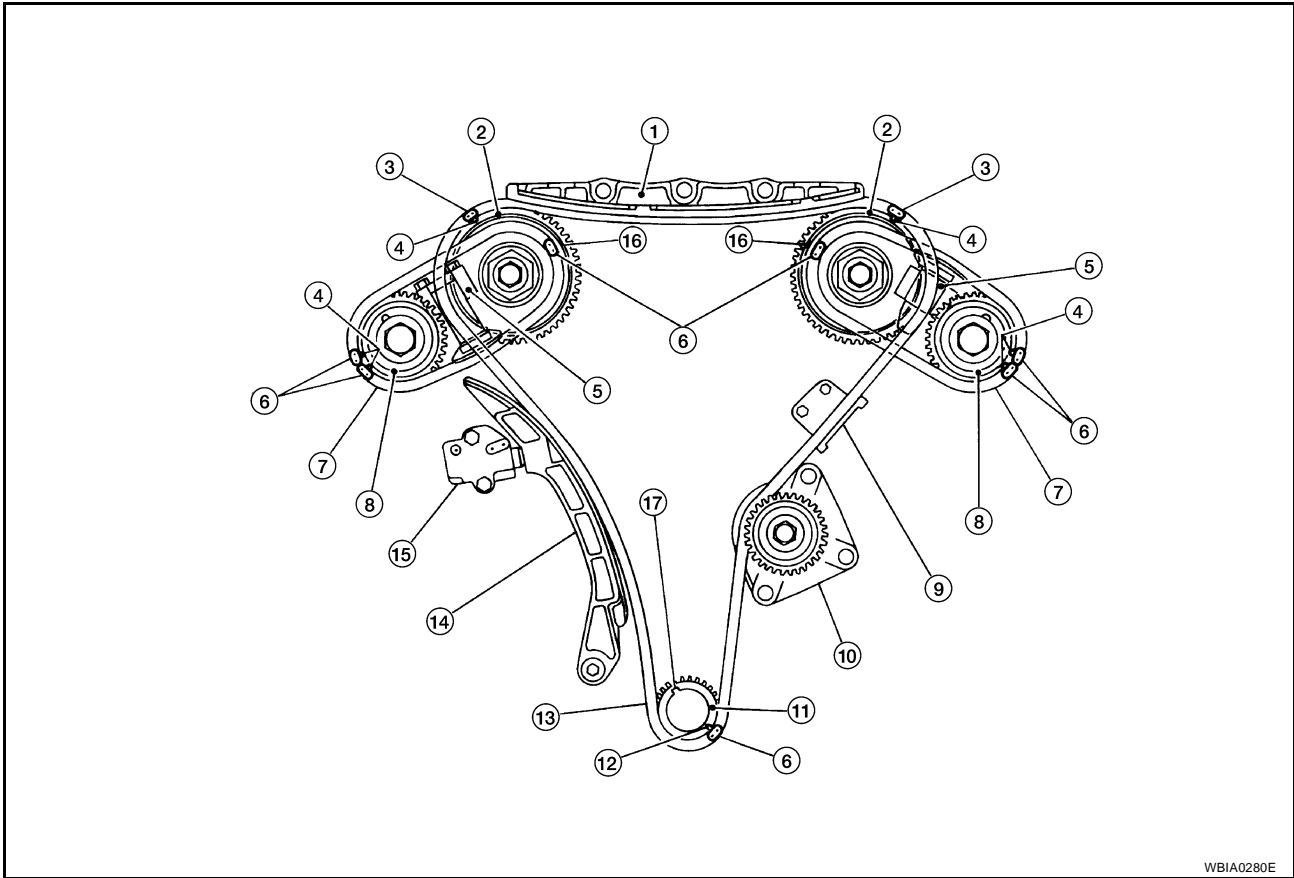

WBIA0280E

- | | | |
|-----------------------------|-------------------------------------|------------------------------------|
| 1. Internal chain guide | 2. Camshaft sprocket (intake) | 3. Mating mark (yellow link) |
| 4. Mating mark (punched) | 5. Secondary timing chain tensioner | 6. Mating mark (gold link) |
| 7. Secondary timing chain | 8. Camshaft sprocket (exhaust) | 9. Timing chain tension guide |
| 10. Water pump | 11. Crankshaft sprocket | 12. Mating mark (notched) |
| 13. Primary timing chain | 14. Slack guide | 15. Primary timing chain tensioner |
| 16. Mating mark (back side) | 17. Crankshaft key | |

1. Install the RH (1) and LH (2) secondary timing chain tensioners (3).

Secondary timing chain tensioner bolts : 8.5 N-m (0.87 kg-m, 75 in-lb)

- O-ring (4)
- Stopper pin (5)

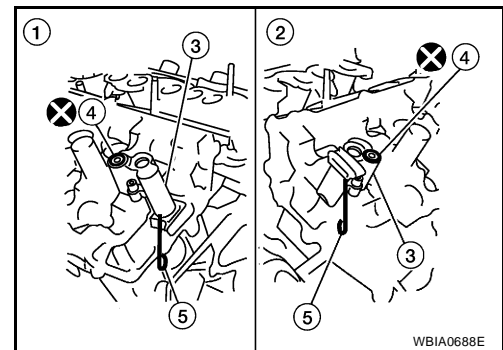

WBIA0688E

TIMING CHAIN

2. Before installing No. 1 camshaft bracket, apply sealant to mating surface.
 - Use Genuine Silicone RTV Sealant, or equivalent. Refer to [GI-46, "RECOMMENDED CHEMICAL PRODUCTS AND SEALANTS"](#).
 - Before installation, wipe off any protruding sealant.
 - Refer to [EM-5, "Precautions for Liquid Gasket"](#).

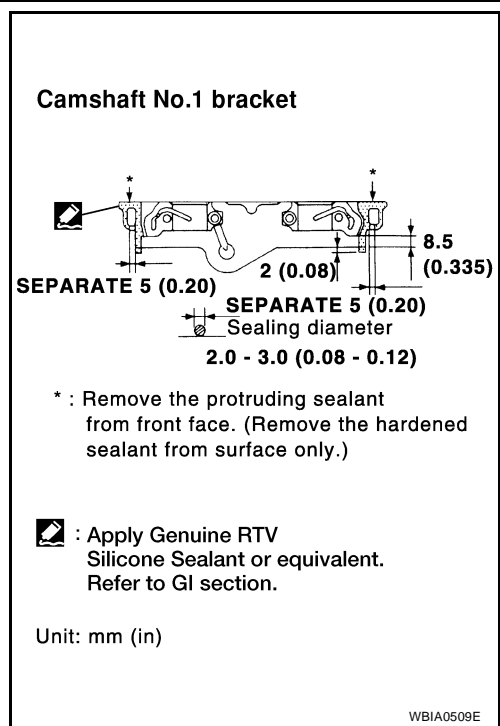

3. Tighten the camshaft brackets in the four steps, as shown.

Camshaft bracket bolts

- | | |
|------------------------------|--|
| Step 1 (bolts 7 - 10) | : 1.96 N·m (0.2 kg·m, 17 in·lb) |
| Step 2 (bolts 1 - 6) | : 1.96 N·m (0.2 kg·m, 17 in·lb) |
| Step 3 | : 5.88 N·m (0.6 kg·m, 52 in·lb) |
| Step 4 | : 10.4 N·m (1.1 kg·m, 92 in·lb) |

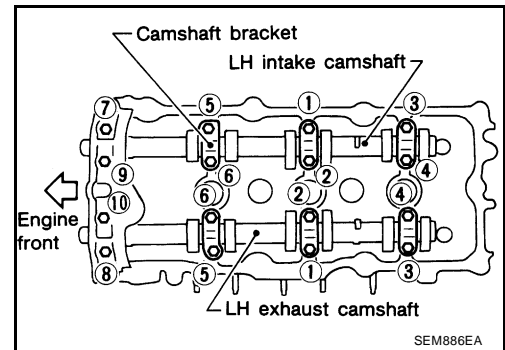
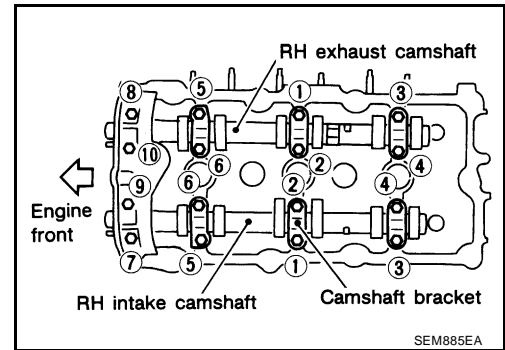

4. Install the engine coolant inlet and thermostat assembly and gasket and coolant inlet housing.

- | | |
|---|--|
| Engine coolant inlet and thermostat assembly bolts | : 9.8 N·m (1.00 kg·m, 87 in·lb) |
|---|--|

TIMING CHAIN

5. Install rear timing chain case as follows:
 - a. Install new O-rings on cylinder block.

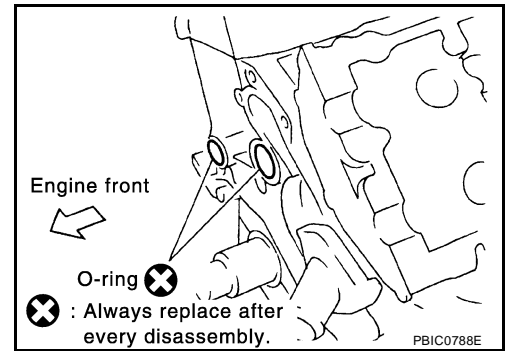

- b. Install new O-rings (4) on RH (1) and LH (2) cylinder heads.
 - Secondary timing chain tensioner (3)
 - Stopper pin (5)

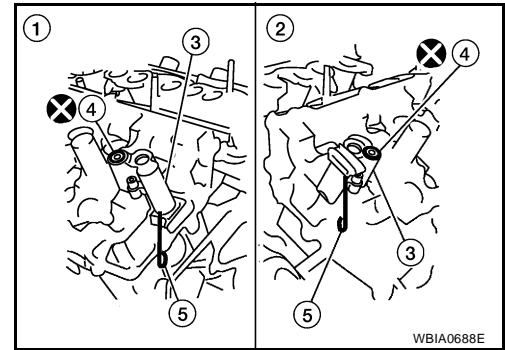

6. If removed, install the water pump. Refer to [CO-20, "INSTALLATION"](#).

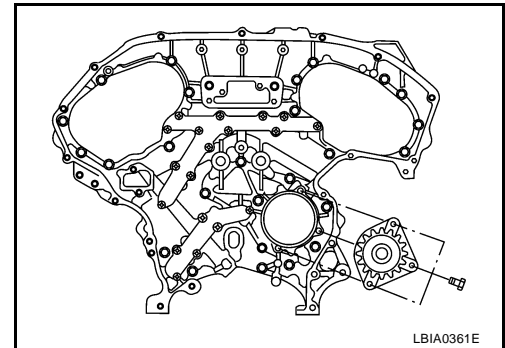

TIMING CHAIN

7. Apply Silicone RTV Sealant to rear timing chain case as shown.

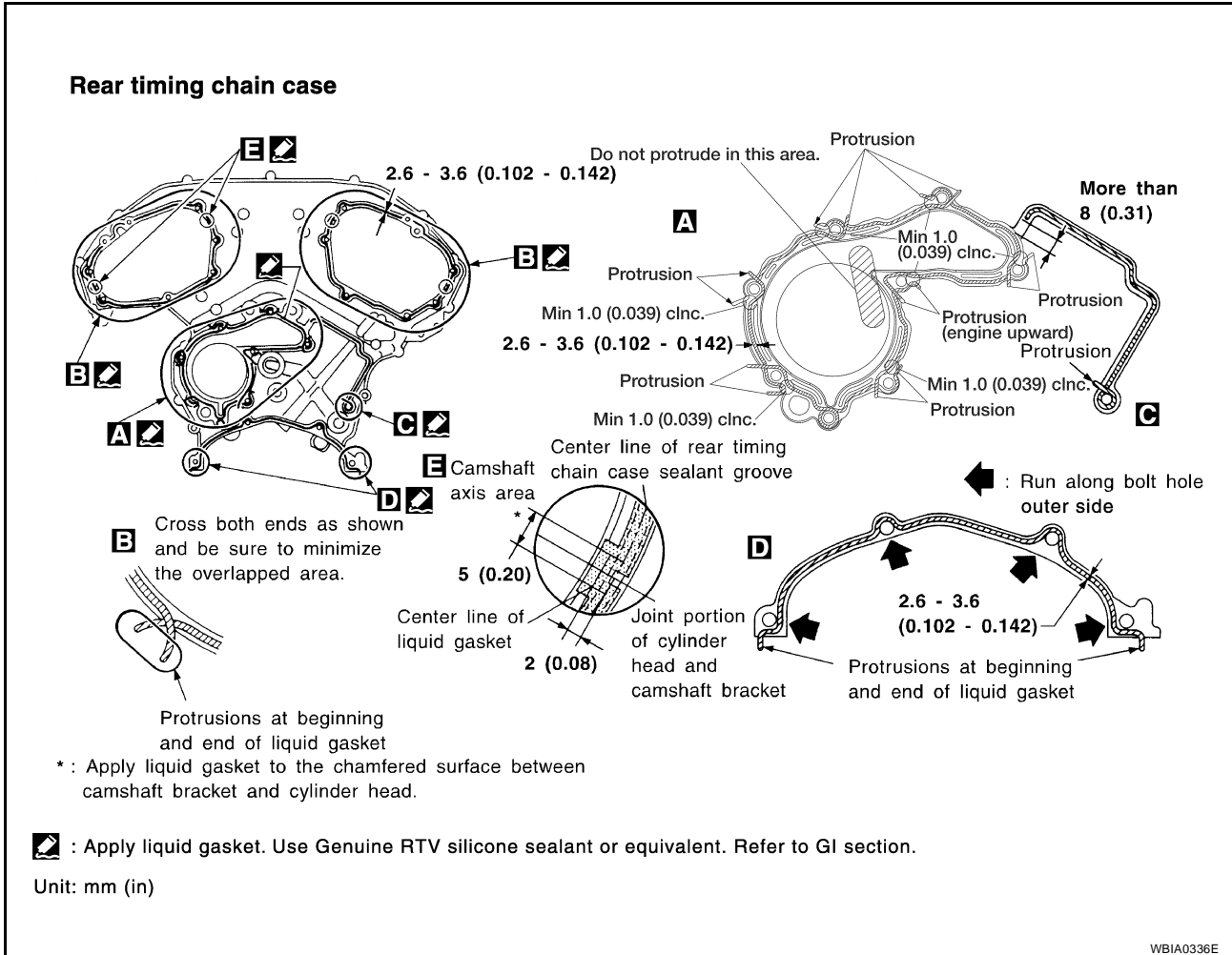

- Use Genuine Silicone RTV Sealant, or equivalent. Refer to [GI-46, "RECOMMENDED CHEMICAL PRODUCTS AND SEALANTS"](#).
- Before installation, wipe off the protruding sealant.

8. Align the rear timing chain case with the dowel pins (RH and LH) on the cylinder block and install the case. Make sure the O-rings stay in place during installation.

a. Tighten the rear timing chain case bolts in the order as shown. There are two bolt lengths used. Follow the chart below for proper bolt length specifications.

Bolt position	Bolt length
1, 2, 3, 6, 7, 8, 9, 10	20 mm (0.79 in)
4, 5, 11 - 26	16 mm (0.63 in)

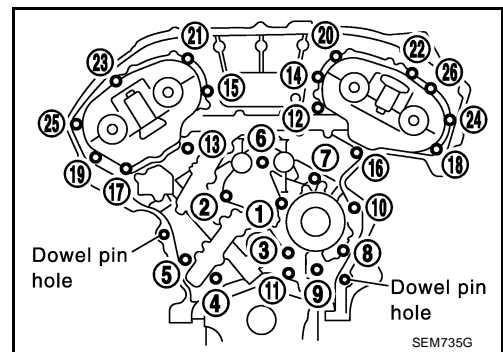

b. After all bolts are initially tightened, retighten them to the specification in the order as shown.

Rear timing chain case bolts : 12.5 N-m (1.3 kg-m, 9 ft-lb)

9. After installing rear timing chain case, check surface height difference between the rear timing chain case to cylinder block.

Standard : -0.24 - 0.14 mm (-0.0094 - 0.0055 in)

- If not within standard, repeat above installation procedure.

10. Install the timing chain tension guide.

TIMING CHAIN

Timing chain tension guide bolts : 21.6 N-m (2.2 kg-m, 16 ft-lb)

11. Position the crankshaft so No. 1 piston is set at TDC on the compression stroke.

- Make sure that the dowel pin hole, dowel pin and crankshaft key are located as shown.
Camshaft dowel pin hole (intake side): at cylinder head upper face side in each bank.
Camshaft dowel pin (exhaust side): at cylinder head upper face side in each bank.
Crankshaft key: at cylinder head side of RH bank.

CAUTION:

Hole on small diameter side must be used for intake camshaft sprocket dowel pin. Do not misidentify (ignore big diameter side).

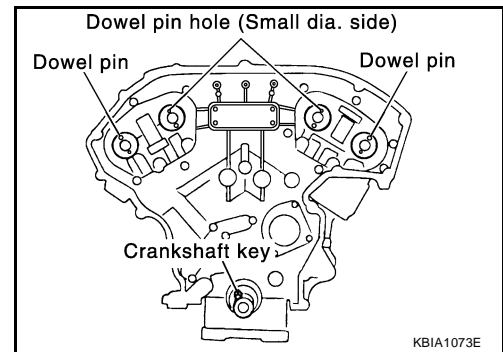

12. Install the secondary timing chains and camshaft sprockets.

CAUTION:

Matching marks between the timing chain and sprockets slip easily. Confirm all matching mark positions repeatedly during the installation process.

- Push the sleeve of the secondary chain tensioner and keep it pressed in with a stopper pin.

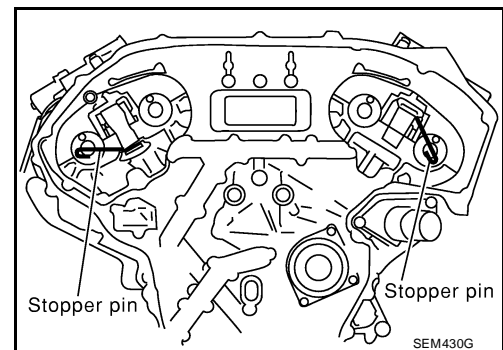

- a. Align the intake (1) and exhaust (9) sprockets (stamped) matching marks (4), (5), (7) and (10) to the secondary timing chain (8) [gold link (2)] and install them.

- Illustration shows RH (rear view)
- Matching marks for the intake sprocket are on the back side of the secondary sprocket.
- There are two types of matching marks, round (7) and (10) and oval (4) and (5) types. They should be used for the RH and LH banks, respectively.
RH bank: use round type (7) and (10).
LH (6) bank: use oval type (4) and (5).

- b. Align the dowel pin (3) and pin hole on the camshaft (1) the dowel pin groove (11) and dowel pin on the camshaft front end, and install them.

- On the intake side, align the pin hole on the small diameter side of the camshaft front end with the dowel pin (3) on the back side of the camshaft sprocket (1), and install them.
- On the exhaust side, align the dowel pin on the camshaft front end with the dowel pin groove (11) on the camshaft sprocket (9), and install them.
- Camshaft sprocket bolts must be tightened in the next step. Tightening them by hand is enough to prevent the dislocation of the dowel pins (3).

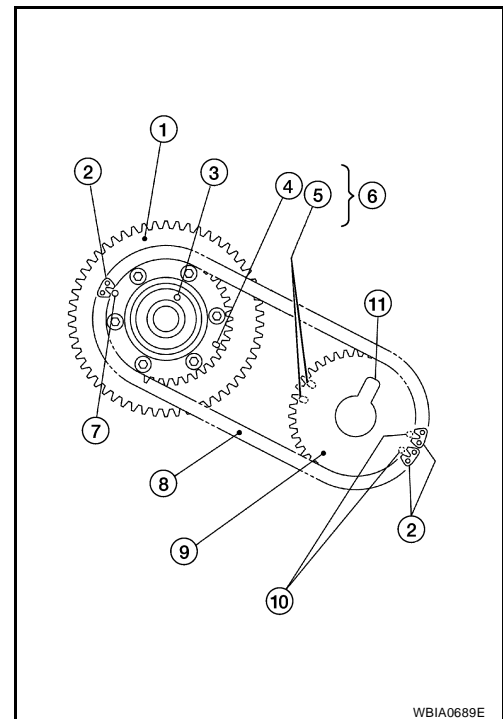

TIMING CHAIN

- It may be difficult to visually check the dislocation of mating marks during and after installation. To make the matching easier, make a mating mark on the sprocket teeth in advance with paint.

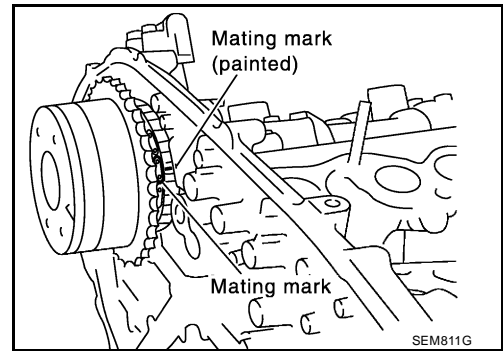

13. After confirming the mating marks are aligned, tighten the camshaft sprocket bolts.

- Secure the camshaft using a wrench at the hexagonal portion to tighten the camshaft sprocket bolts.

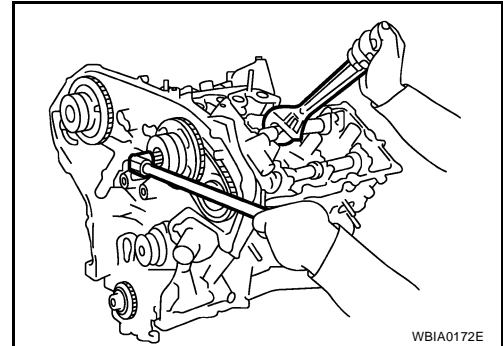

14. Pull the stopper pins (1) out from the secondary timing chain tensioners (2) and (3).

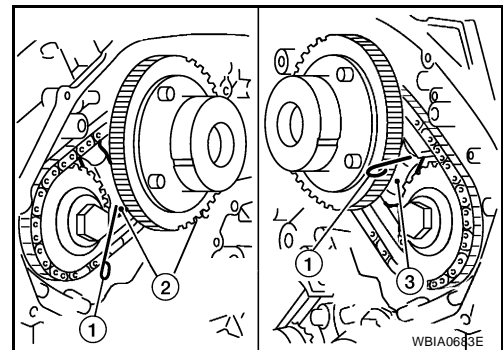

15. Install the crankshaft sprocket on the crankshaft.

- Make sure the mating marks on the crankshaft sprocket face the front of the engine.

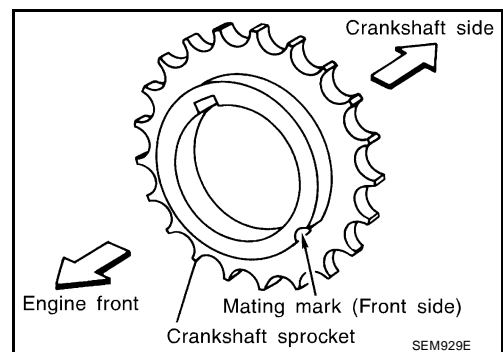

A
EM
C
D
E
F
G
H
I
J
K
L
M

TIMING CHAIN

16. Install the primary timing chain.

- Install primary timing chain so the mating mark (punched) on camshaft sprocket is aligned with the yellow link on the timing chain, while the mating mark (notched) on the crankshaft sprocket is aligned with the gold link on the timing chain, as shown.
- When it is difficult to align mating marks of the primary timing chain with each sprocket, gradually turn the camshaft using a wrench on the hexagonal portion to align it with the mating marks.
- During alignment, be careful to prevent dislocation of mating mark alignments of the secondary timing chains.

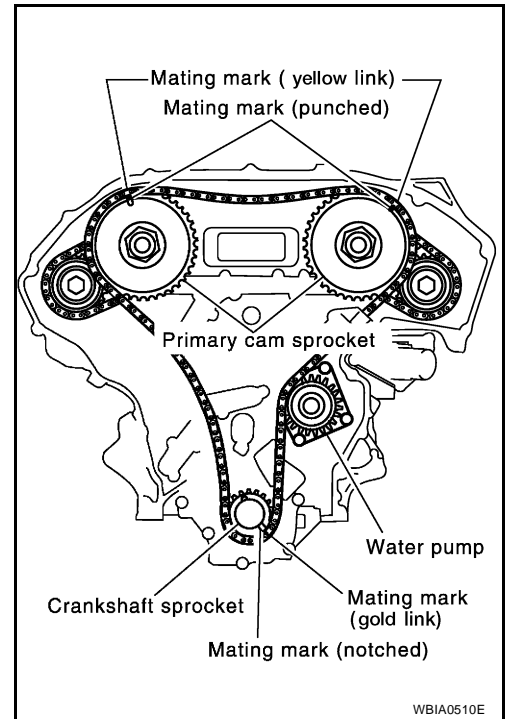

17. Install the internal chain guide.

- Timing chain tensioner (2)
- Timing chain tensioner guide (3)
- Slack guide (4)

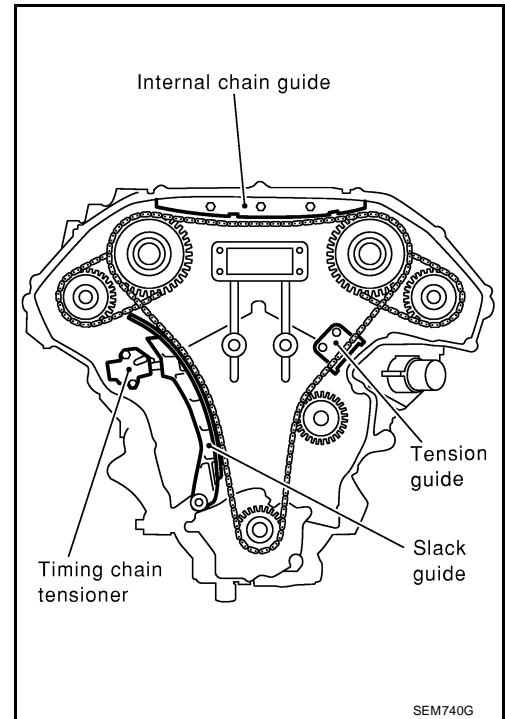

18. Install the slack guide.

- Do not overtighten the slack guide installation bolt. It is normal for a gap to exist under the bolt seats when the installation bolt are tightened to specification.

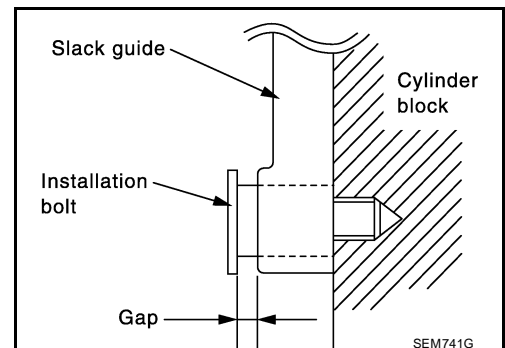

TIMING CHAIN

19. Install the timing chain tensioner (1) and slack guide (6).
- a. Install the timing chain tensioner (1) and install the timing chain tensioner installation bolts (7).
 - b. Keep the slack guide (6) pressed and hold it by pushing the stopper pin (3) through the lever hole and body hole as shown.
 - c. Insert plunger (5) into tensioner body hole by pressing the slack guide (6).
- ←: Press slack guide
- d. Insert stopper pin (3) into tensioner body hole to hold lever (4), and keep the tab (2) released. An Allen wrench [2.5 mm (0.098 in)] (3) is used for a stopper pin as an example.
 - e. Pull lever (4) down and release plunger stopper tab (2). Plunger stopper tab (2) can be pushed up to release (coaxial structure with lever (4)).
- ←: pull lever
 - When installing the chain tensioner, push in the sleeve and keep it pressed in with the stopper pin.
 - Remove any dirt and foreign materials completely from the back and the mounting surfaces of the chain tensioner.
 - After installation, pull out the stopper pin by pressing the slack guide.

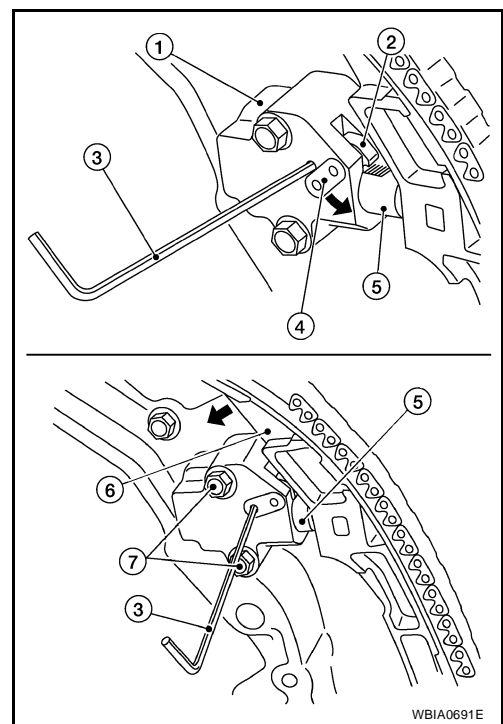

20. Reconfirm that the matching marks on the sprockets and the timing chain have not slipped out of alignment.
21. Install new RH (1) and LH (2) O-rings (3) on the rear timing chain case.

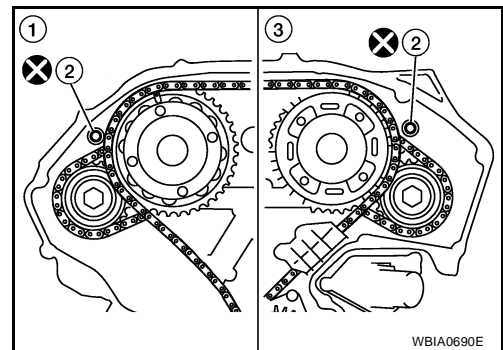

22. Install the front oil seal on the front timing chain case using a suitable tool. Apply clean engine oil to the oil seal edges.
- Install it so that each seal lip is oriented as shown.

Suitable drift

Outer diameter : 59 mm (2.32 in)

Inner diameter : 49 mm (1.93 in)

CAUTION:

Press fit straight and avoid causing burrs or tilting the oil seal.

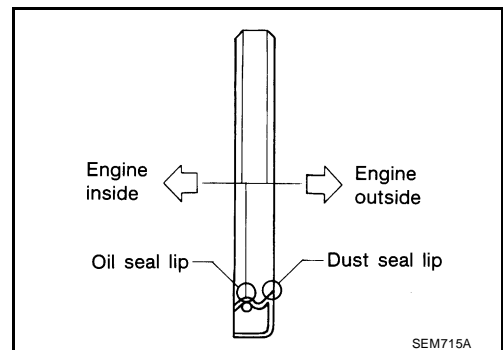

TIMING CHAIN

- Press-fit oil seal until it becomes flush with timing chain case end face, using a suitable drift.
- Make sure the garter spring in the oil seal is in position and seal lip is not inverted.

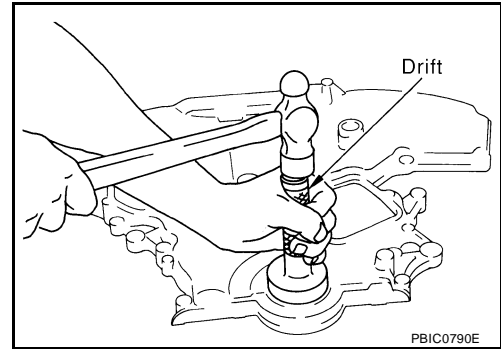

23. Apply Silicone RTV Sealant to front timing chain case as shown.

- Use Genuine Silicone RTV Sealant, or equivalent. Refer to [MA-9. "RECOMMENDED FLUIDS AND LUBRICANTS"](#).
- Before installation, wipe off the protruding sealant.
- If removed install dowel pin on the rear timing chain case into dowel pin hole in front timing chain case.

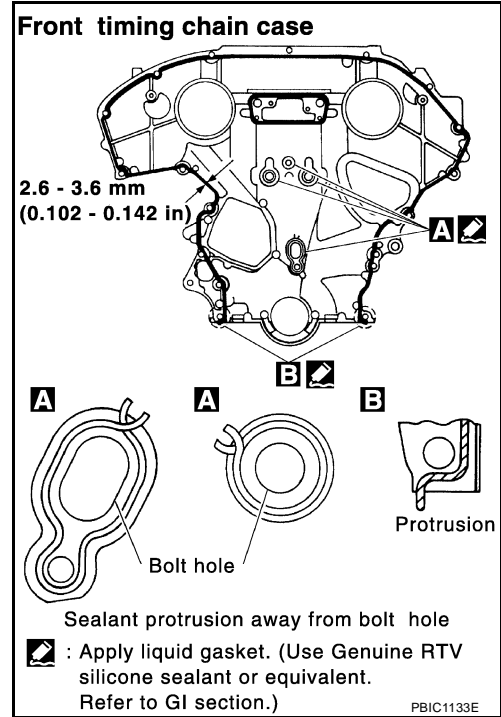

24. Loosely install the front timing chain case bolts.

Bolt position	Bolt diameter
1, 2	: 8 mm (0.31 in)
3 – 22	: 6 mm (0.24 in)

25. Tighten the front timing chain case bolts in the order as shown.

- Retighten the front timing chain case bolts in the order as shown.

Bolt position	Tightening specification
1, 2	: 28.5 N·m (2.9 kg·m, 21 ft·lb)
3 – 22	: 12.8 N·m (1.3 kg·m, 9 ft·lb)

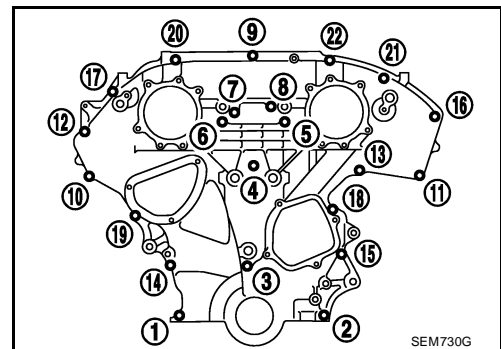

TIMING CHAIN

26. After installing the front timing chain case, check the surface height difference between the following parts on the oil pan mounting surface.

- If not within specification, repeat the installation procedure.

Front timing chain case to rear timing chain case : (-0.14) - 0.14 mm [(-0.0055) - 0.0055 in]

Front timing chain case to cylinder block : (-0.36) - (-0.10) mm [(-0.0142) - (-0.0039) in]

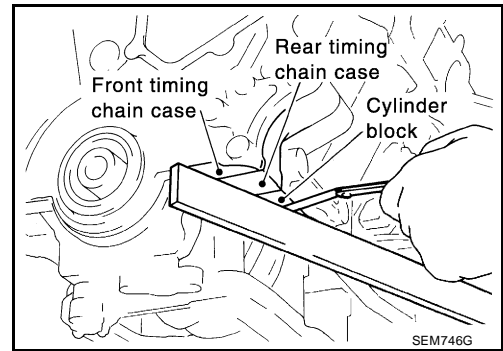

27. Install IVT control valve covers as follows:

a. Install new collared O-rings in front cover oil hole (LH and RH sides).

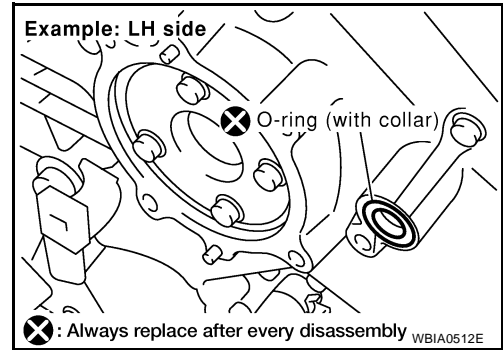

b. Install new seal rings on the IVT control covers.

c. Apply Silicone RTV Sealant to the IVT control covers.

- Use Genuine Silicone RTV Sealant, or equivalent. Refer to [GI-46, "RECOMMENDED CHEMICAL PRODUCTS AND SEALANTS"](#).

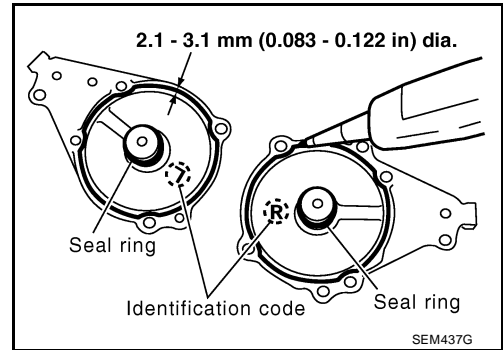

- Being careful not to move the seal ring from the installation groove, align the dowel pins on the chain case with the holes to install the IVT control covers.

- Tighten the intake valve timing control cover bolts in the order as shown.

Intake valve timing control cover bolts : 11.3 N-m (1.2 kg-m, 100 in-lb)

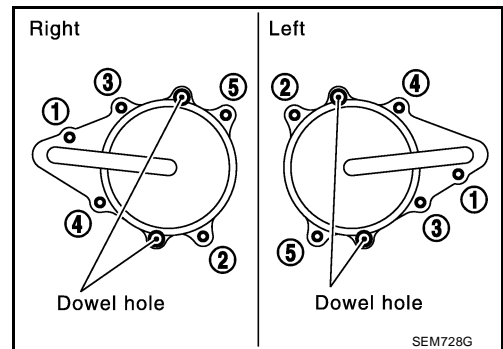

28. Apply liquid gasket and install the chain tensioner cover.

- Use Genuine Silicone RTV Sealant or equivalent. Refer to [GI-46, "RECOMMENDED CHEMICAL PRODUCTS AND SEALANTS"](#).

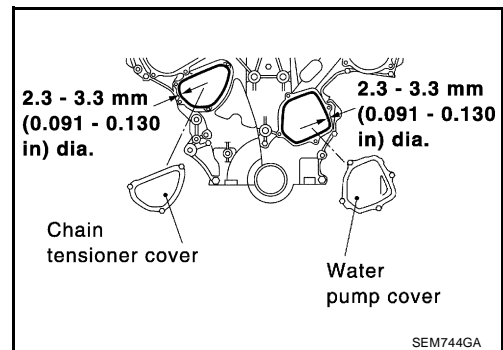

TIMING CHAIN

29. Install the RH engine mounting insulator, mount and bracket. Refer to [EM-112, "Removal and Installation"](#).
30. Install the rocker covers. Refer to [EM-44, "INSTALLATION"](#).
31. Install the IVT control solenoid valve bank 1 and bank 2.

IVT control solenoid valve bolts : 11.3 N-m (1.2 kg-m, 100 in-lb)

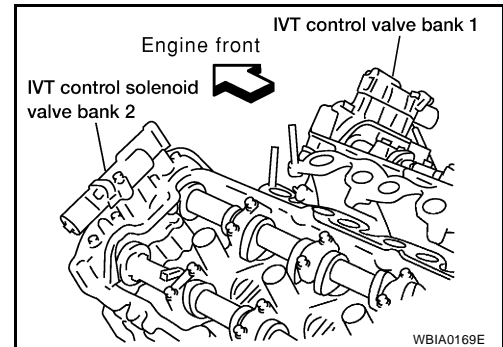

32. Install the six spark plugs in their original positions refer to [EM-39, "INSTALLATION"](#).
33. Install the intake manifold collectors (upper and lower). Refer to [EM-20, "INSTALLATION"](#).
34. Install crankshaft pulley and tighten the bolt in two steps.
- Lubricate thread and seat surface of the bolt with new engine oil.
 - For the second step of angle tightening. Using Tool.

Step 1 : 44 N-m (4.5 kg-m, 32 ft-lb)

Step 2 : 84° - 90° degrees clockwise

Tool number : KV10112100 (BT-8653-A)

35. Remove Tool.

Tool number : KV10117700 (J-44716)

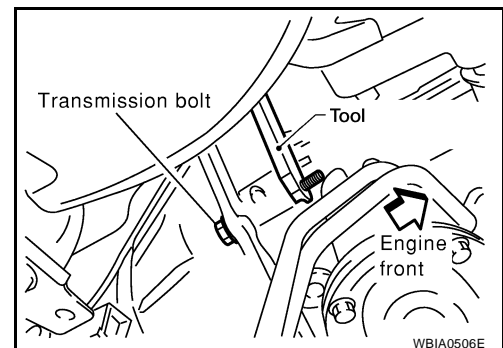

36. Rotate crankshaft pulley in normal direction (clockwise when viewed from front) to confirm it turns smoothly.
37. Installation of the remaining components is in reverse order of removal.
38. Refill the engine with oil and coolant. Refer to [MA-9, "Fluids and Lubricants"](#).

CAUTION:

- **Wait at least 30 minutes for the Silicone RTV Sealant to set before filling the engine with fluids to avoid leaks.**
- **Activate the fuel system. Check for any leaks when the system is repressurized and correct as necessary.**
- **Start the engine and check all systems for leaks or improper operation. Correct as necessary.**
- **After starting engine, keep idling for three minutes. Then rev engine up to 3,000 rpm under no load to purge air from the high-pressure oil chamber of the chain tensioners. The engine may produce a rattling noise. This indicates that air still remains in the chamber and is not a matter of concern.**

TIMING CHAIN

INSPECTION AFTER INSTALLATION

Inspection for Leaks

The following are procedures for checking fluid leaks, lubricant leaks and exhaust gases leaks.

- Before starting engine, check oil/fluid levels including engine coolant and engine oil. If less than required quantity, fill to the specified level. Refer to [MA-9, "Fluids and Lubricants"](#) .
- Use procedure below to check for fuel leakage.
- Turn ignition switch "ON" (with engine stopped). With fuel pressure applied to fuel piping, check for fuel leakage at connection points.
- Start engine. With engine speed increased, check again for fuel leakage at connection points.
- Run engine to check for unusual noise and vibration.

NOTE:

If hydraulic pressure inside timing chain tensioner drops after removal/installation, slack in the guide may generate a pounding noise during and just after engine start. However, this is normal. Noise will stop after hydraulic pressure rises.

- Warm up engine thoroughly to make sure there is no leakage of fuel, exhaust gases, or any oil/fluids including engine oil and engine coolant.
- Bleed air from lines and hoses of applicable lines, such as in cooling system.
- After cooling down engine, again check oil/fluid levels including engine oil and engine coolant. Refill to the specified level, if necessary.

Summary of the inspection items:

Item	Before starting engine	Engine running	After engine stopped
Engine coolant	Level	Leakage	Level
Engine oil	Level	Leakage	Level
Other oils and fluid*	Level	Leakage	Level
Fuel	Leakage	Leakage	Leakage

* Transmission/transaxle/CVT fluid, power steering fluid, brake fluid, etc.

CAMSHAFT

PF1:13001

EBS00PRU

CAMSHAFT

Removal and Installation

SEC. 111•118•130•140•220

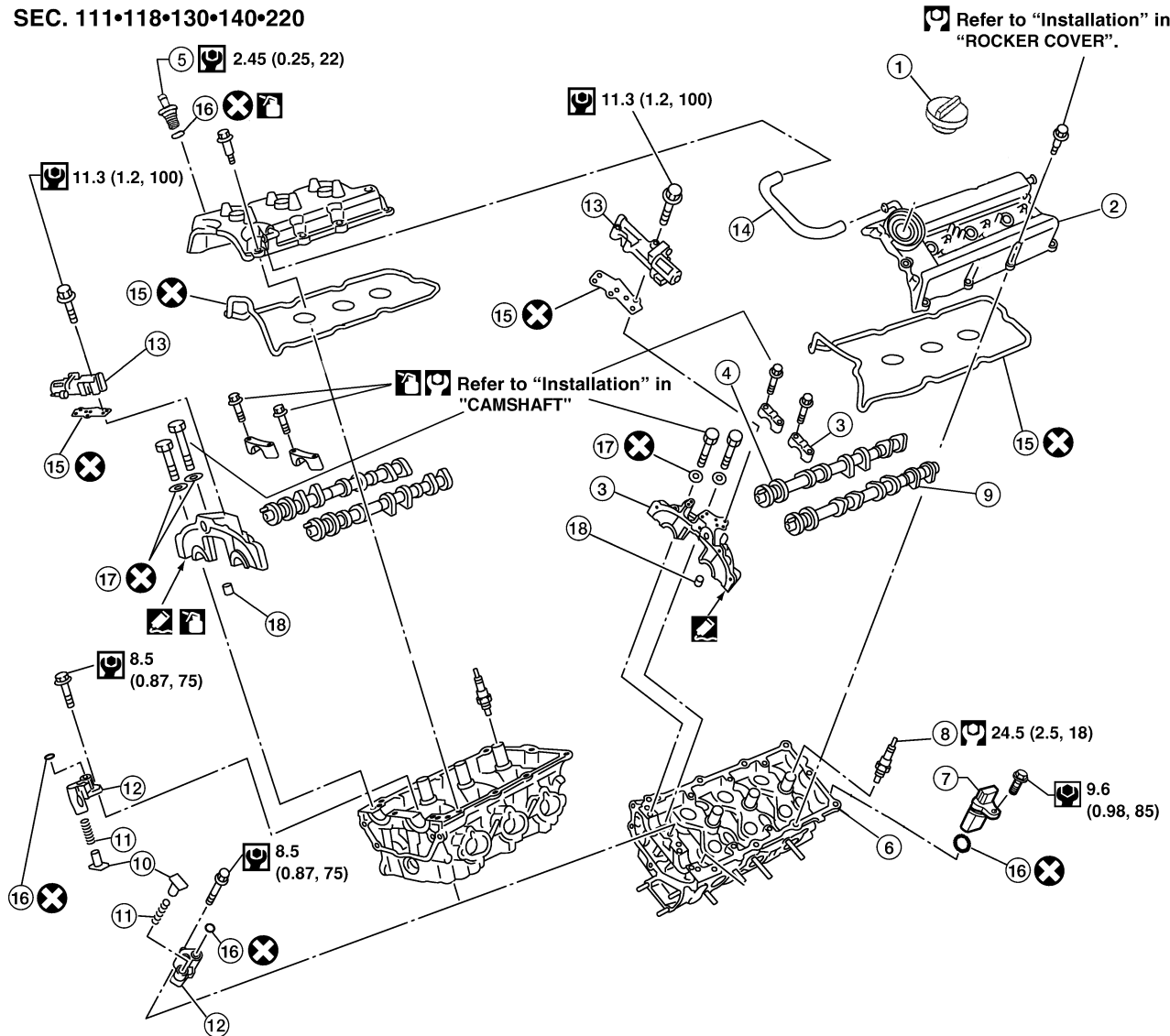

- : Apply Genuine Silicone RTV Sealant or equivalent.
Refer to GI Section.
- : Lubricate with engine oil
- : N·m (kg-m, ft-lb)
- : N·m (kg-m, in-lb)
- : Always replace after every disassembly.

WBIA0515E

- | | | |
|-------------------------------------|----------------------|--|
| 1. Oil filler cap | 2. Rocker cover (LH) | 3. Camshaft bracket (LH) |
| 4. Camshaft (INT) | 5. PCV valve | 6. Cylinder head (LH) |
| 7. Camshaft position sensor (PHASE) | 8. Spark plug | 9. Camshaft (EXH) |
| 10. Tensioner sleeve | 11. Tensioner spring | 12. Secondary camshaft chain tensioner |
| 13. IVT control solenoid valve | 14. PCV hose | 15. Gasket |
| 16. O-ring | 17. Seal washer | 18. Dowel pin |

CAUTION:
Apply new engine oil to parts marked in illustration before installation.

CAMSHAFT

REMOVAL

1. Remove the timing chains. Refer to [EM-56, "Removal and Installation"](#).
2. If necessary, remove camshaft position sensor (PHASE) (right and left bank) from cylinder head back side.

CAUTION:

- Handle carefully to avoid dropping and shocks.
- Do not disassemble.
- Do not allow any metal particles to adhere to magnetic part at sensor tip.
- Do not place sensors in a location where they are exposed to magnetism.

Example: Left bank

Keep off any magnetic materials.

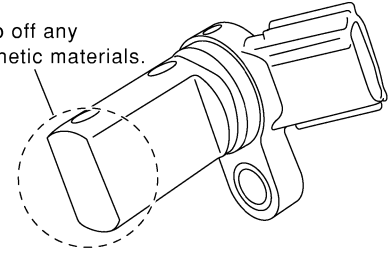

KBIA1046E

3. Remove the IVT control solenoid valves.
 - Discard the IVT control solenoid valve gaskets and use new gaskets for installation.

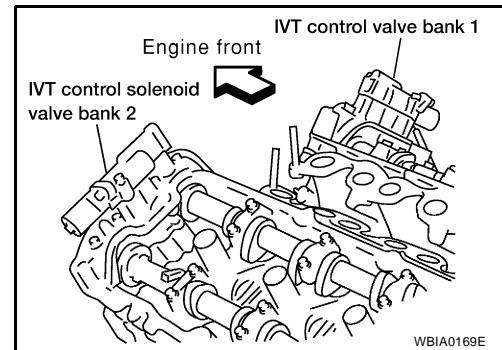

WBIA0169E

4. Remove the intake and exhaust camshaft brackets and the camshafts.
 - Mark the camshafts, camshaft brackets, and bolts so they are placed in the same position and direction for installation.
 - Equally loosen the camshaft bracket bolts in several steps in the order as shown.

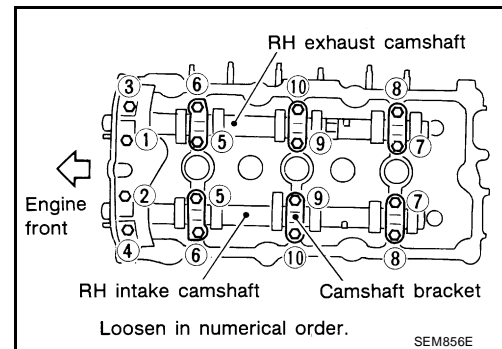

SEM856E

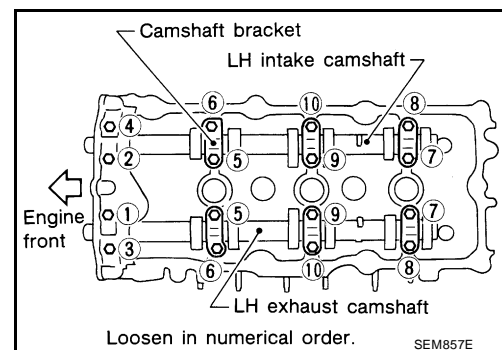

SEM857E

5. Remove valve lifters.

NOTE:
Identify installation positions to ensure proper installation.

CAMSHAFT

- Remove camshaft RH (1) and LH (2) secondary timing chain tensioner (3) from cylinder head with the stopper pin (5) inserted.

NOTE:

Stopper pin (5) was installed when secondary timing chain was removed.

- O-rings (4)

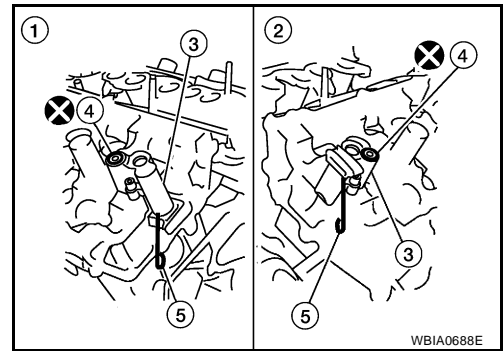

INSPECTION AFTER REMOVAL

Camshaft Visual Check

Check camshaft for scratches, seizure and wear. Replace if necessary.

Camshaft Runout

- Put V-block on precise flat bed and support No. 2 and No. 4 journal of camshaft as shown.
- Set dial gauges vertically to No. 3 journal as shown.
- Turn camshaft in one direction slowly by hand, measure the camshaft runout on the dial gauges.
 - Runout is the largest indicator reading after one full revolution.

Camshaft Runout

Standard : Less than 0.02 mm (0.0008 in)

Limit : 0.05 mm (0.0020 in)

- If actual runout exceeds the limit, replace the camshaft.

Camshaft Cam Lobe Height

- Measure camshaft cam lobe height as shown. Refer to [EM-150, "CAMSHAFT AND CAMSHAFT BEARING"](#).
- If wear has reduced the lobe height below specifications, replace the camshaft.

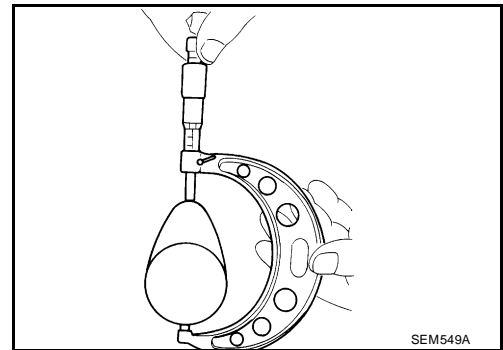
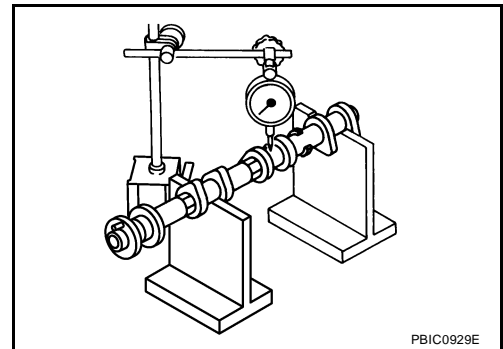

Camshaft Journal Clearance

Outer Diameter of Camshaft Journal

- Measure outer diameter of camshaft journal as shown.

Standard outer diameter, No.1 : 25.935 - 25.955 mm (1.0211 - 1.0218 in)

Standard outer diameter, No.2, 3, 4 : 23.445 - 23.465 mm (0.9230 - 0.9238 in)

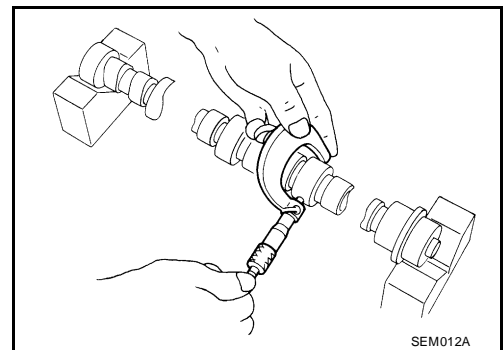

CAMSHAFT

Inner Diameter of Camshaft Bracket

1. Tighten camshaft bracket bolts to specified torque. Refer to [EM-82, "INSTALLATION"](#).
2. Using inside micrometer, measure inner diameter "A" of camshaft bearing.

Standard inner diameter	: 26.000 - 26.021 mm
No. 1	(1.0236 - 1.0244 in)
Standard inner diameter	: 23.500 - 23.521 mm
No. 2, 3, 4	(0.9252 - 0.9260 in)

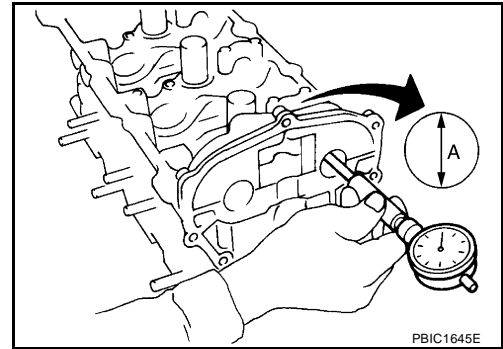

Calculation of Camshaft Journal to Bracket Clearance

(Journal clearance) = (inner diameter of camshaft bracket) – (outer diameter of camshaft journal)

Standard	: 0.045 - 0.086 mm (0.0018 - 0.0034 in)
No.1	
Standard No.	: 0.035 - 0.076 mm (0.0014 - 0.0030 in)
2, 3, 4	
Limit	: 0.15 mm (0.0059 in)

- When out of the specified range, replace either or both camshaft and cylinder head.

NOTICE:

Inner diameter of camshaft bracket is manufactured together with cylinder head. Replace the whole cylinder head assembly.

Camshaft End Play

1. Install the camshaft in the cylinder head. Refer to [EM-82, "INSTALLATION"](#).
2. Install dial gauge in thrust direction on front end of camshaft. Measure end play when camshaft is moved forward/backward (in direction to axis) as shown.

Standard	: 0.115 - 0.188 mm (0.0045 - 0.0074 in)
Limit	: 0.24 mm (0.0094 in)

- If out of the specified range, replace with new camshaft and measure again.
- If out of the specified range again, replace with new cylinder head.

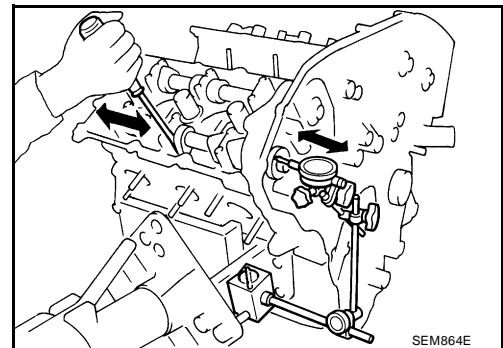

Camshaft Sprocket Runout

1. Put V-block on precise flat bed and support No. 2 and No. 4 journal of camshaft as shown.
2. Install camshaft sprocket on camshaft.
3. Measure camshaft sprocket runout.

Limit	: 0.15 mm (0.0059 in)
--------------	------------------------------

4. If sprocket runout exceeds the limit, replace camshaft sprocket.

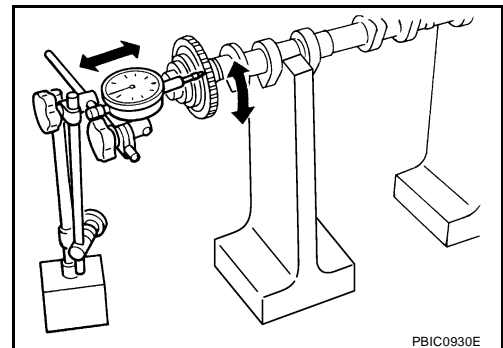

CAMSHAFT

Valve Lifter

- Check if the surface of the valve lifter has any excessive wear or cracks, replace as necessary.

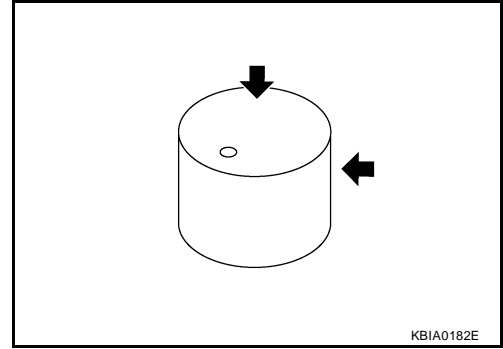

Valve Lifter Clearance

Outer Diameter of Valve Lifter

- Measure the outer diameter of the valve lifter. Refer to [EM-147, "Valve Lifter"](#).
- If out of the specified range, replace the valve lifter.

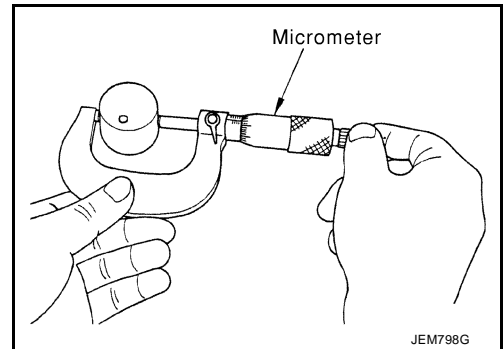

Valve Lifter Bore Diameter

- Using inside micrometer, measure diameter of valve lifter bore of cylinder head. Refer to [EM-147, "Valve Lifter"](#).
- If out of the specified range, replace the cylinder head assembly.

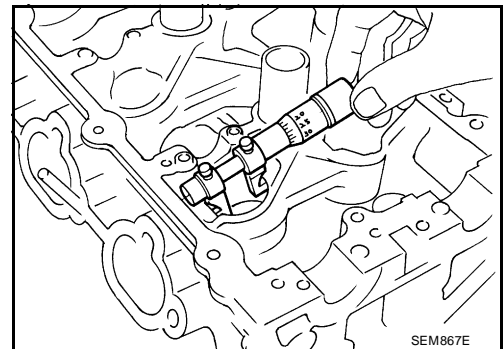

Calculation of Valve Lifter Clearance

- (Valve lifter clearance) = (hole diameter for valve lifter) – (outer diameter of valve lifter). Refer to [EM-147, "Valve Lifter"](#).
- If out of specified range, replace either or both valve lifter and cylinder head assembly.

INSTALLATION

1. Before installation, remove any old Silicone RTV Sealant from component mating surfaces using suitable tool.

CAUTION:

Do not scratch or damage the mating surfaces.

NOTE:

Remove the old Silicone RTV Sealant from the bolt holes and threads.

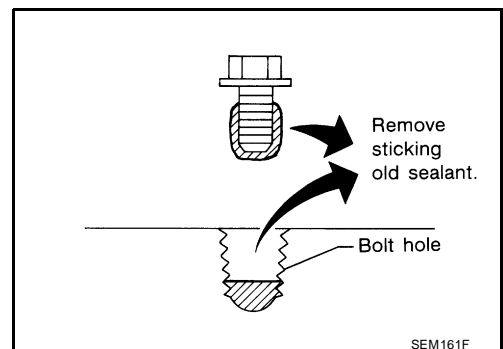

CAMSHAFT

2. Before installing the No. 1 camshaft bracket, remove the old Silicone RTV Sealant from the mating surface using suitable scraper.

CAUTION:

Do not scratch or damage the mating surface.

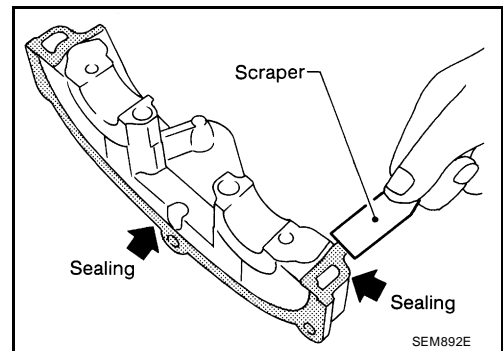

3. Turn the crankshaft until No. 1 piston is set at TDC on the compression stroke.
 - The crankshaft key should line up with the right bank cylinder center line as shown.

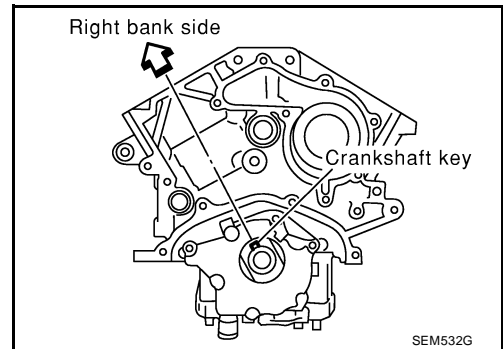

4. Install the RH (1) and LH (2) secondary timing chain tensioners (3) on the cylinder heads.
 - O-rings (4)
 - Stopper pins (5)

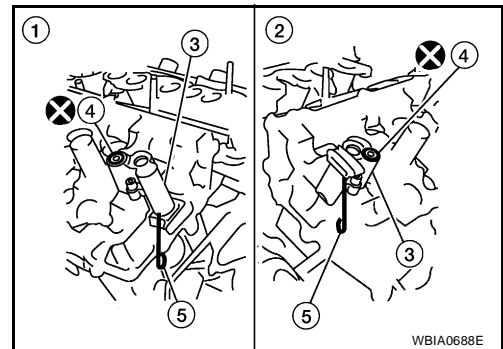

5. Install valve lifters.

NOTE:

Install them in original positions.

6. Install exhaust and intake camshafts and camshaft brackets.

- Intake camshaft has a drill mark on camshaft sprocket mounting flange.

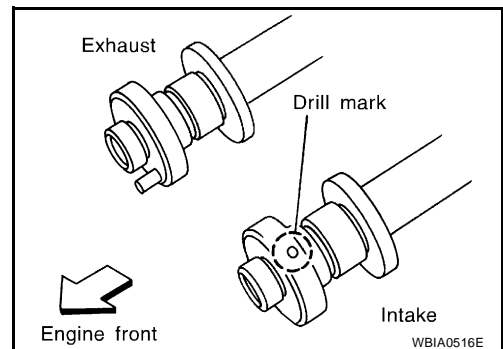

CAMSHAFT

- Follow your identification marks (2) and (3) made during removal, or follow the identification marks (1) that are present on the new camshafts components for proper placement and direction of the components.

← Indicates engine front

Bank	INT/EXH	Identification mark (1)	Drill mark	Paint marks	
				M1 (3)	M2 (2)
RH (4)	INT	RE	Yes	Yes	No
	EXH	RE	No	No	Yes
LH (5)	INT	LH	Yes	Yes	No
	EXH	LH	No	No	Yes

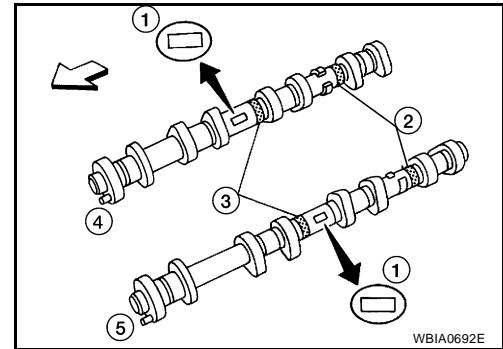

- Position the camshafts:
RH exhaust camshaft dowel pin at about 10 o'clock.
LH exhaust camshaft dowel pin at about 2 o'clock.

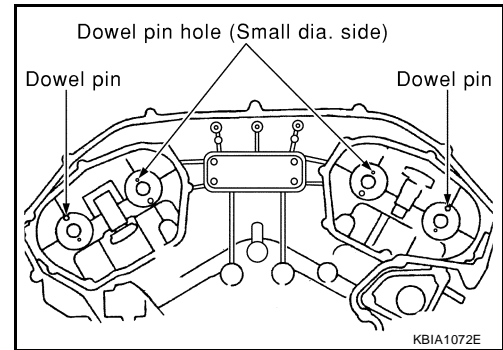

7. Before installing No. 1 camshaft brackets, apply sealant to mating surface of No. 1 camshaft bracket.

- Use Genuine Silicone RTV Sealant, or equivalent. Refer to [GI-46, "RECOMMENDED CHEMICAL PRODUCTS AND SEALANTS"](#).

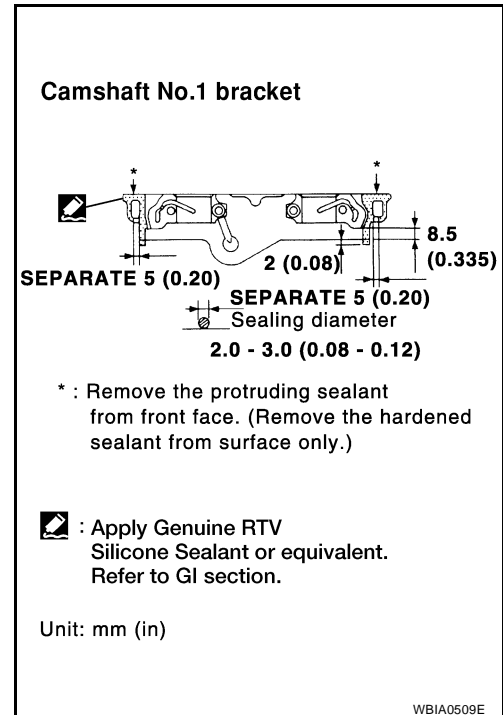

CAMSHAFT

- Before installation, wipe off any protruding sealant.
- Refer to [EM-5, "Precautions for Liquid Gasket"](#) .

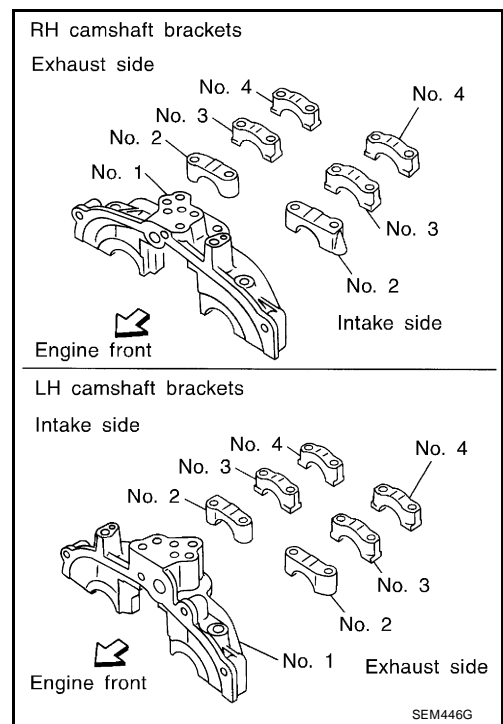

- Install remaining camshaft brackets in their original positions and direction. Align the stamp marks as shown.
- If checking and adjusting any part of valve assembly or camshaft, check valve clearance according to the reference data. Refer to [EM-87, "Valve Clearance"](#) .

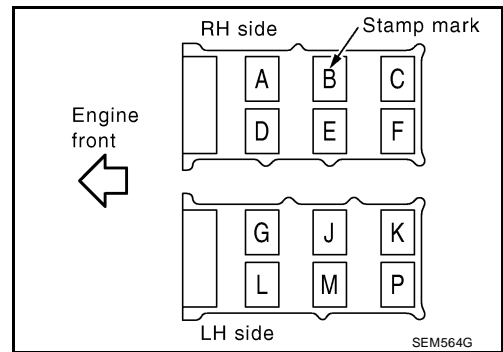

8. Tighten the camshaft brackets in the four steps, as shown.

Camshaft bracket bolts

Step 1 (bolts 7 - 10) : 1.96 N·m (0.2 kg·m, 17 in·lb)

Step 2 (bolts 1 - 6) : 1.96 N·m (0.2 kg·m, 17 in·lb)

Step 3 : 5.88 N·m (0.6 kg·m, 52 in·lb)

Step 4 : 10.4 N·m (1.1 kg·m, 92 in·lb)

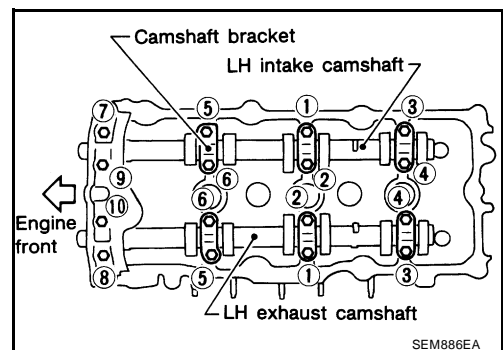
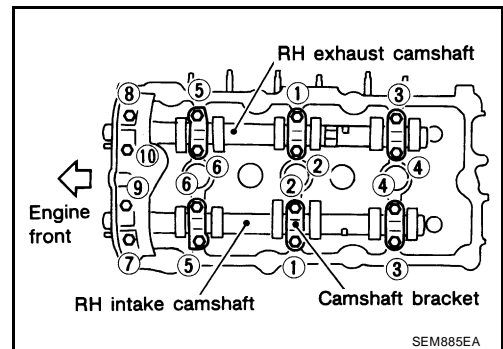

CAMSHAFT

9. Measure difference in levels between front end faces of No.1 camshaft bracket and cylinder head.

Standard : - 0.14 (- 0.0055 in)

- If measurement is outside the specified range, re-install camshaft and camshaft bracket.

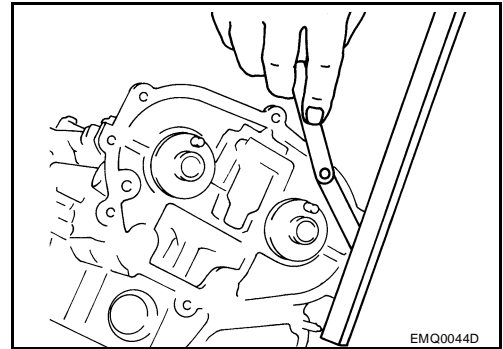

10. Install the IVT control solenoid valves with new gaskets.

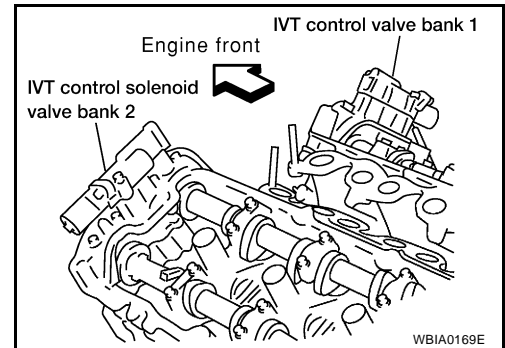

11. If necessary, install camshaft position sensor (PHASE) (RH and LH bank.)
12. Install the timing chains. Refer to [EM-56, "Removal and Installation"](#) .

CAMSHAFT

EBS00PRV

Inspection After Installation

INSPECTION OF CAMSHAFT SPROCKET (INT) OIL GROOVE

CAUTION:

- Perform this inspection only when DTC P0011 or P0021 are detected in self-diagnostic results of CONSULT-II and it is directed according to inspection procedure of EC section. Refer to [EC-122, "SELF-DIAG RESULTS MODE"](#) .
 - Check when engine is cold so as to prevent burns from any splashing engine oil.
1. Check the engine oil level. Refer to [LU-8, "ENGINE OIL"](#) .
 2. Perform the following procedure so as to prevent the engine from being unintentionally started while checking.
 - a. Release fuel pressure. Refer to [EC-82, "FUEL PRESSURE RELEASE"](#) .
 - b. Disconnect ignition coil and injector harness connectors.
 3. Remove intake valve timing control solenoid valve. Refer to [EM-78, "CAMSHAFT"](#) .
 4. Crank the engine, and then make sure that engine oil comes out from camshaft bracket (No. 1) oil hole. End crank after checking.

WARNING:

Be careful not to touch rotating parts (drive belts, idler pulley, and crankshaft pulley, etc.).

CAUTION:

Engine oil may squirt from intake valve timing control solenoid valve installation hole during cranking. Use a shop cloth to protect the engine components and the vehicle. Do not allow engine oil to get on rubber components such as drive belt or engine mount insulators. Immediately wipe off any splashed engine oil.

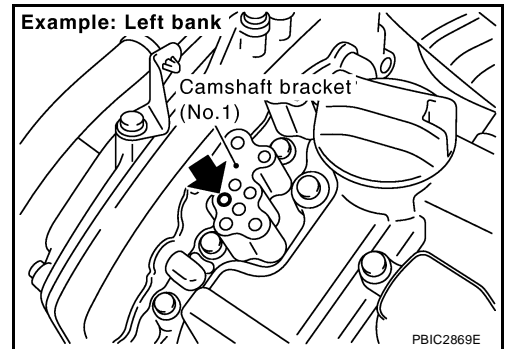

- Clean oil groove between oil strainer and intake valve timing control solenoid valve if engine oil does not come out from camshaft bracket (No. 1) oil hole. Refer to [LU-6, "LUBRICATION SYSTEM"](#) .
5. Remove components between intake valve timing control solenoid valve and camshaft sprocket (INT), and then check each oil groove for clogging.
 - Clean oil groove if necessary. Refer to [LU-6, "LUBRICATION SYSTEM"](#) .
 6. After inspection, install removed parts.

Valve Clearance CHECKING

EBS00PRW

Perform inspection as follows after removal, installation or replacement of camshaft or valve related parts, or if there is unusual engine conditions regarding valve clearance.

NOTE:

Check valve clearance while engine is cold and not running.

1. Remove the intake manifold collectors. Refer to [EM-19, "REMOVAL"](#) .
2. Remove the ignition coils. Refer to [EM-36, "REMOVAL"](#) .
3. Remove the rocker covers. [EM-43, "REMOVAL"](#) .
4. Set No.1 cylinder at TDC on its compression stroke.

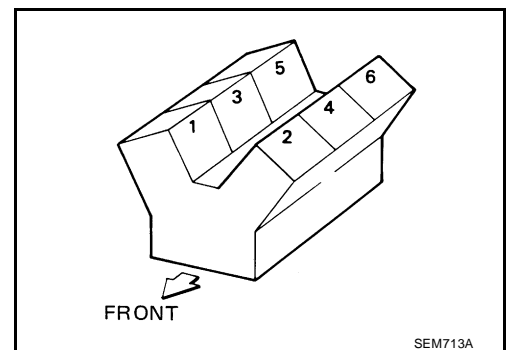

CAMSHAFT

- Align pointer with TDC mark on crankshaft pulley.

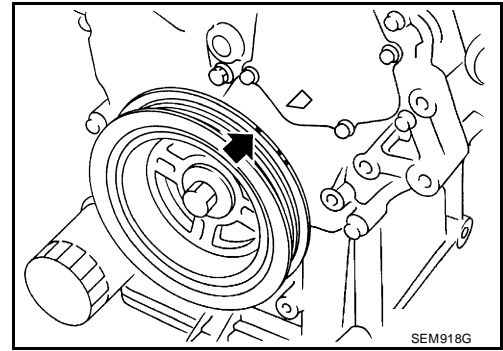

- Check that the valve lifters on No.1 cylinder are loose and valve lifters on No.4 are tight. If not, turn the crankshaft one full revolution (360°) and align as shown.
 - RH cylinder head (1)
 - ⇐ Engine front

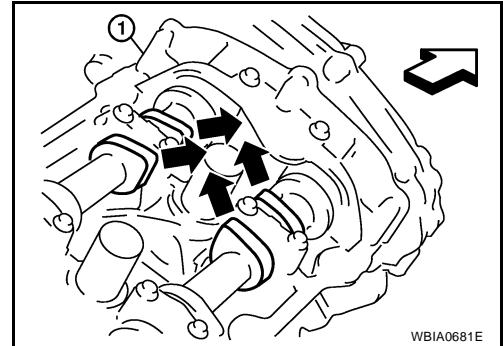

5. Check only the valves as shown.

Crank Position	Valve No. 1	Valve No. 2	Valve No. 3	Valve No. 6
No. 1 TDC	Intake	Exhaust	Exhaust	Intake

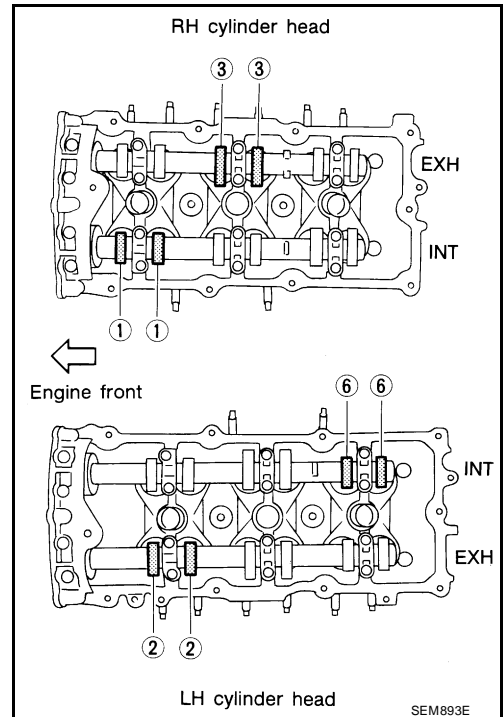

- Using a feeler gauge, measure the clearance between the valve lifter and camshaft.
- Record any valve clearance measurements which are out of specification. They will be used later to determine the required replacement lifter size.

Valve Clearance for Checking (cold)

Intake : 0.26 - 0.34 mm (0.010 - 0.013 in)

Exhaust : 0.29 - 0.37 mm (0.011 - 0.015 in)

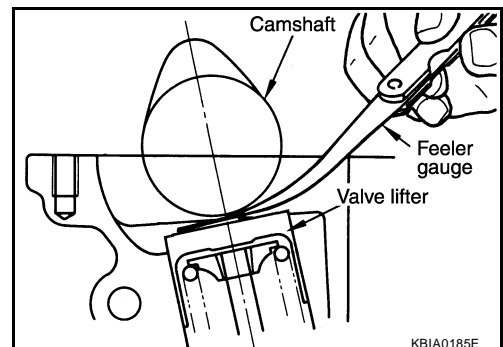

CAMSHAFT

6. Turn crankshaft 240°.
7. Set No.3 cylinder at TDC on its compression stroke.
8. Check only those valves as shown.

Crank Position	Valve No. 2	Valve No. 3	Valve No. 4	Valve No. 5
No. 3 TDC	Intake	Intake	Exhaust	Exhaust

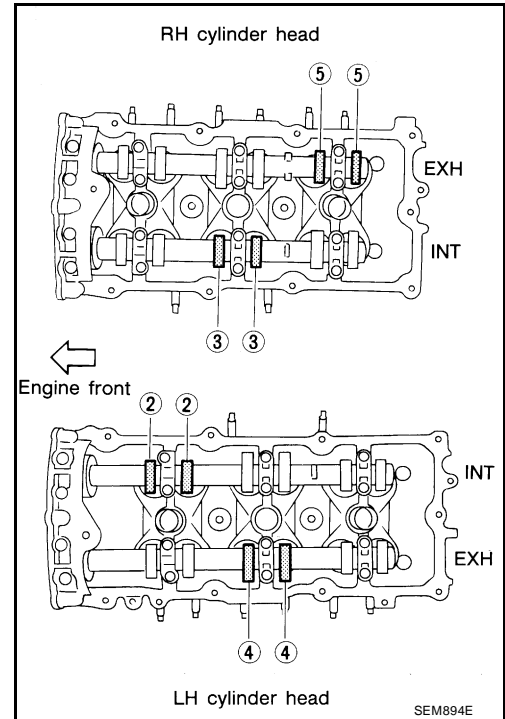

9. Turn the crankshaft 240° and align as above.
10. Set No.5 cylinder at TDC on its compression stroke.
11. Check only those valves as shown.

Crank Position	Valve No. 1	Valve No. 4	Valve No. 5	Valve No. 6
No. 5 TDC	Exhaust	Intake	Intake	Exhaust

12. If all valve clearances are within specification, installation of the remaining components is in the reverse order of removal. If the valve clearances are out of specification, adjust the valve clearances. Refer to [EM-90, "VALVE ADJUSTING"](#).

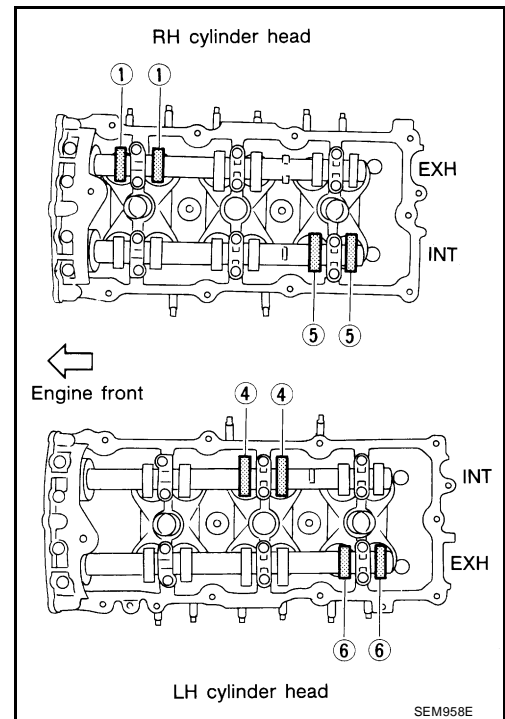

CAMSHAFT

VALVE ADJUSTING

CAUTION:

Adjust valve clearance while engine is cold.

NOTE:

- Perform adjustment by selecting the correct head thickness of the valve lifter (adjusting shims are not used).
 - The specified valve lifter thickness is the dimension at normal temperatures. Ignore dimensional differences caused by temperature. Use specifications for hot engine condition to confirm valve clearances.
1. Remove the camshaft. Refer to [EM-79, "REMOVAL"](#) .
 2. Remove the valve lifter that was measured as being outside the standard specifications.
 3. Measure the center thickness of the removed lifter with a micrometer as shown.

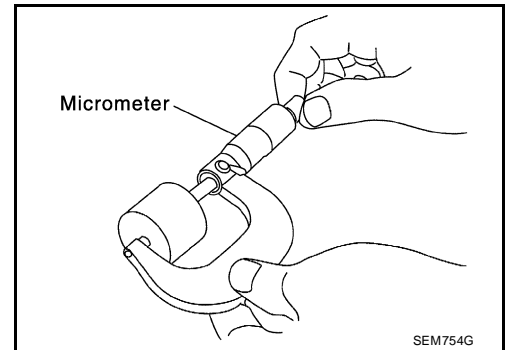

4. Use the equation below to calculate valve lifter thickness for replacement.

Valve lifter thickness calculation: $t = t_1 + (C_1 - C_2)$

t = Valve lifter thickness to be replaced

t₁ = Removed valve lifter thickness

C₁ = Measured valve clearance

C₂ = Standard valve clearance:

Intake : 0.30 mm (0.012 in)*

Exhaust : 0.33 mm (0.013 in)*

***: Approximately 20°C (68°F)**

- Thickness of new valve lifter can be identified by stamp marks on the reverse side (inside the cylinder).

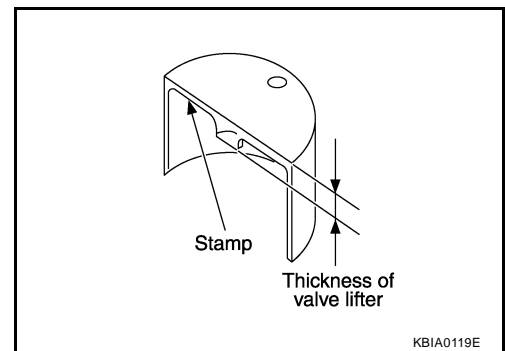

Intake and Exhaust

Stamp mark	Thickness
788U	7.88 mm (0.3102 in)
840U	8.40 mm (0.3307 in)

Available thickness of valve lifter: 27 sizes with range 7.88 to 8.40 mm (0.3102 to 0.3307 in) in steps of 0.02 mm (0.0008 in) (when manufactured at factory). Refer to [EM-147, "Available Valve Lifter"](#) .

CAUTION:

Install identification letter at the end and top, "U" and "N", at each of proper positions. (Be careful of mis-installation between intake and exhaust.)

5. Install the selected replacement valve lifter.

CAMSHAFT

6. Install the camshaft. Refer to [EM-82, "INSTALLATION"](#) .
7. Rotate the crankshaft a few turns by hand.
8. Confirm that the valve clearances are within specification.
9. After the engine has been run to full operating temperature, confirm that the valve clearances are within specification.

Valve Clearance	Cold	Hot* (reference data)
Intake	0.26 - 0.34 mm (0.010 - 0.013 in)	0.304 - 0.416 mm (0.012 - 0.016 in)
Exhaust	0.29 - 0.37 mm (0.011 - 0.015 in)	0.308 - 0.432 mm (0.012 - 0.017 in)

* Approximately 80°C (176°F)

INSPECTION AFTER INSTALLATION

- Before starting engine, check the levels of engine coolant, engine oil and working fluid. If less than required quantity, fill to the specified level.
- Use procedure below to check for fuel leakage.
- Turn ignition switch ON (with engine stopped). With fuel pressure applied to fuel piping, check for fuel leakage at connection points.
- Start engine. With engine speed increased, check again for fuel leakage at connection points.
- Run engine to check for unusual noise and vibration.
- Warm up engine thoroughly to make sure there is no leakage of engine coolant, engine oil, working fluid, fuel and exhaust gas.
- Bleed air from passages in pipes and tubes of applicable lines, such as in cooling system.
- After cooling down engine, again check amounts of engine coolant, engine oil and working fluid. Refill to specified level, if necessary.
- Summary of the inspection items:

Item	Before starting engine	Engine running	After engine stopped
Engine coolant	Level	Leakage	Level
Engine oil	Level	Leakage	Level
Working fluid	Level	Leakage	Level
Fuel	Leakage	Leakage	Leakage
Exhaust gas	—	Leakage	—

*Transmission/transaxle/CVT fluid, power steering fluid, brake fluid, etc.

OIL SEAL

Removal and Installation of Valve Oil Seal

EBS00PRX

1. Remove camshaft and valve lifter relating to valve oil seal to be removed. Refer to [EM-78, "Removal and Installation"](#) .
2. Rotate crankshaft, and set piston whose oil seal is to be removed to top dead center. This prevents valve from dropping inside cylinder.

CAUTION:

When rotating crankshaft, be careful to avoid scarring the front timing chain case with the timing chain.

3. Remove valve collet, valve spring retainer and valve spring using Tool.

Tool numbers : KV10116200 (J-26336-B)
 : KV10115900 (J-26336-20)
 : KV10109230 (—)

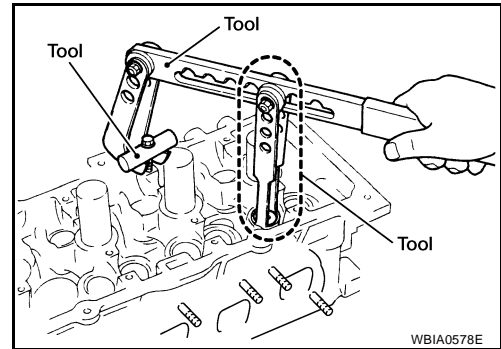

4. Remove valve oil seal using Tool.

Tool number : KV10107902 (J-38959)

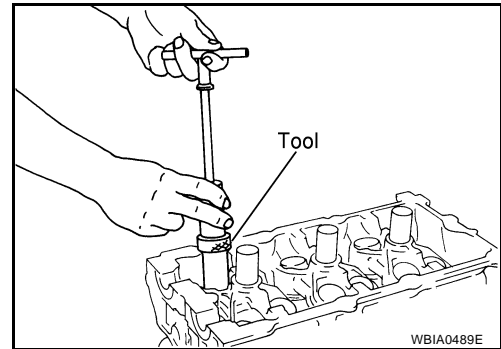

INSTALLATION

1. Apply new engine oil to new valve oil seal joint surface and seal lip.
2. Press in valve oil seal to height "H" using Tool to specified height.

Tool number : — (J-39386)

NOTE:

Dimension "H": height measured before valve spring seat installation.

Intake and exhaust : 14.3 - 14.9 mm (0.563 - 0.587 in)

3. Installation of the remaining components is in the reverse order of removal.

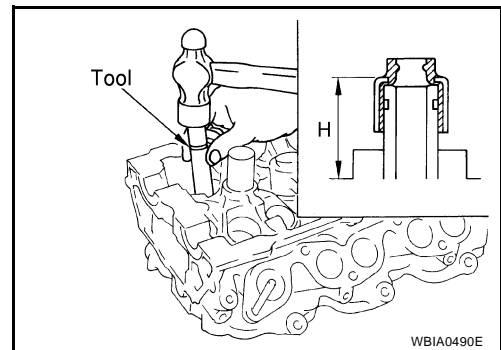

Removal and Installation of Front Oil Seal

EBS00PRY

REMOVAL

1. Remove the following parts:
 - Engine undercover.
 - Drive belts. Refer to [EM-13, "DRIVE BELTS"](#) .
 - Radiator fan. Refer to [CO-15, "Removal and Installation"](#) .
2. Remove the crankshaft pulley as follows:
 - a. Remove the starter motor. Refer to [SC-16, "Removal and Installation"](#) .

OIL SEAL

- b. Lock the ring gear using Tool attached to the starter bolt hole.

Tool number : KV10117700 (J-44716)

CAUTION:

Do not damage the ring gear teeth, or the signal plate teeth behind the ring gear when setting the Tool.

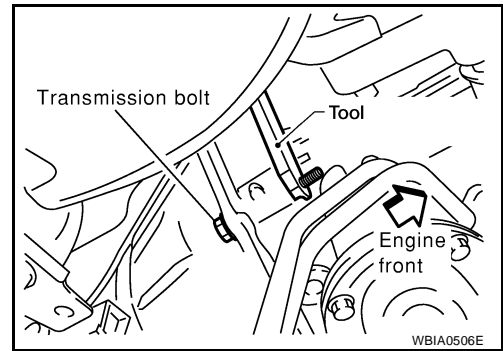

- c. Loosen crankshaft pulley bolt and locate bolt seating surface at 10 mm (0.39 in) from its original position.

- d. Position a pulley puller at recess hole of crankshaft pulley to remove crankshaft pulley.

CAUTION:

Do not use a puller claw on crankshaft pulley periphery.

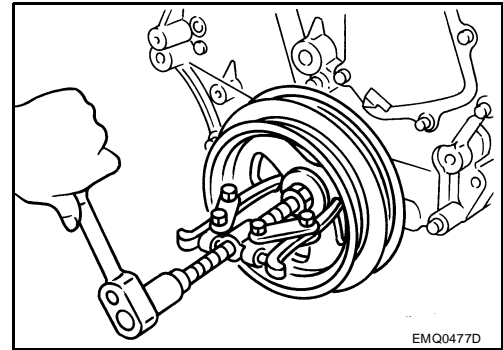

3. Remove front oil seal from front timing chain case.

CAUTION:

Be careful not to damage front timing chain case or crankshaft.

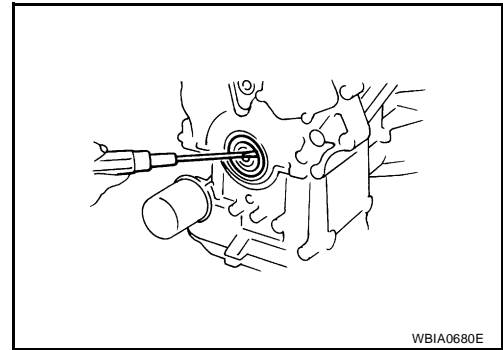

INSTALLATION

1. Install the front oil seal on the front timing chain case using a suitable tool. Apply clean engine oil to the oil seal edges.

- Install it so that each seal lip is oriented as shown.

Suitable drift

Outer diameter : 59 mm (2.32 in)

Inner diameter : 49 mm (1.93 in)

CAUTION:

Press fit straight and avoid causing burrs or tilting the oil seal.

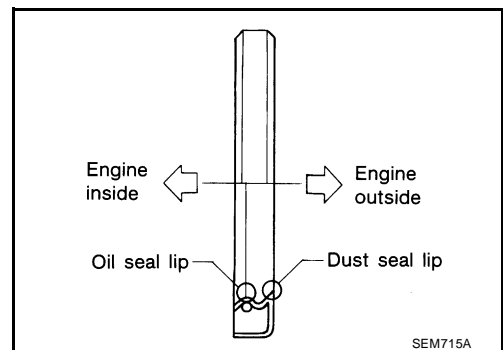

OIL SEAL

- Press-fit oil seal until it becomes flush with timing chain case end face, using a suitable drift.
- Make sure the garter spring in the oil seal is in position and seal lip is not inverted.

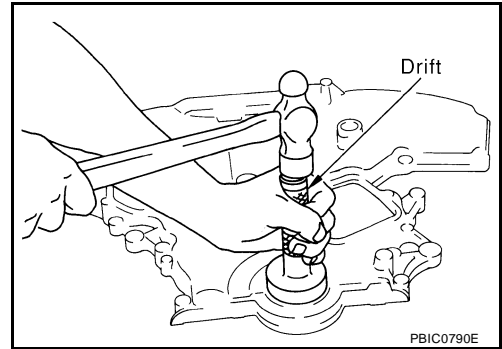

2. Install crankshaft pulley and tighten the bolt in two steps.
 - Lubricate thread and seat surface of the bolt with new engine oil.
 - For the second step of angle tightening. Use Tool.

Step 1 : 44 N-m (4.5 kg-m, 32 ft-lb)

Step 2 : 84° - 90° degrees clockwise

Tool number : KV10112100 (BT-8653-A)

3. Remove Tool attached to the starter bolt hole.

Tool number : KV10117700 (J-44716)

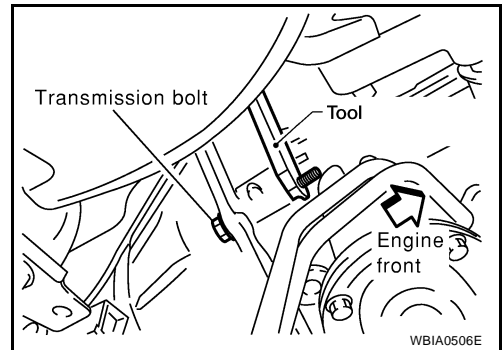

4. Rotate crankshaft pulley in normal direction (clockwise when viewed from front) to confirm it turns smoothly.
5. Installation of the remaining components is in reverse order of removal.

OIL SEAL

EBS00QUT

Removal and Installation of Rear Oil Seal

REMOVAL

1. Remove transmission assembly. Refer to [AT-239, "REMOVAL AND INSTALLATION"](#) .
2. Remove rear oil seal with a suitable tool.

CAUTION:

Be careful not to damage crankshaft and cylinder block.

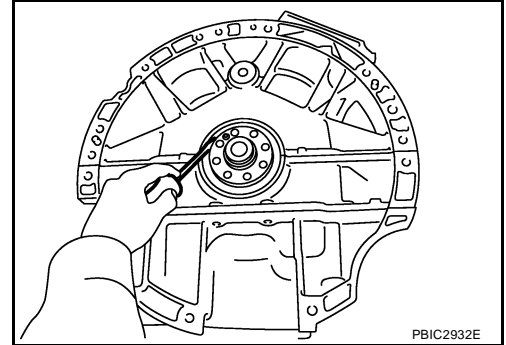

INSTALLATION

1. Apply new engine oil to new rear oil seal joint surface and seal lip.
2. Install rear oil seal so that each seal lip is oriented as shown.

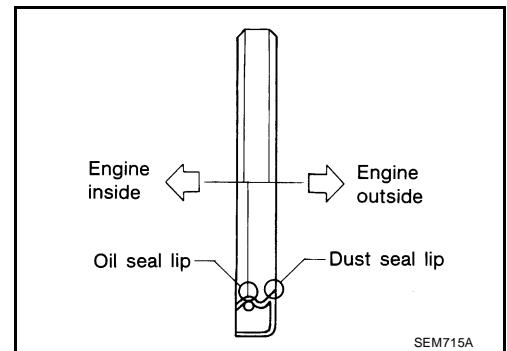

- Press in rear oil seal to the position as shown.

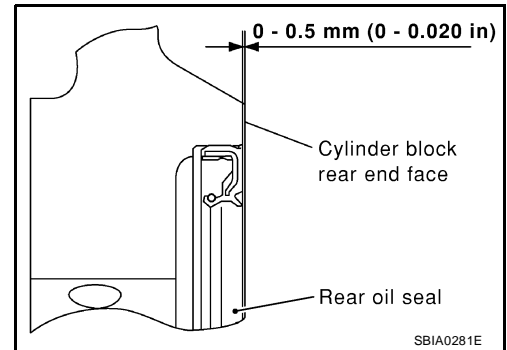

- Press-fit rear oil seal using Tool.

Tool number : — (J-47128)

CAUTION:

- Be careful not to damage crankshaft and cylinder block.
- Press-fit oil seal straight to avoid causing burrs or tilting.
- Do not touch grease applied onto oil seal lip.

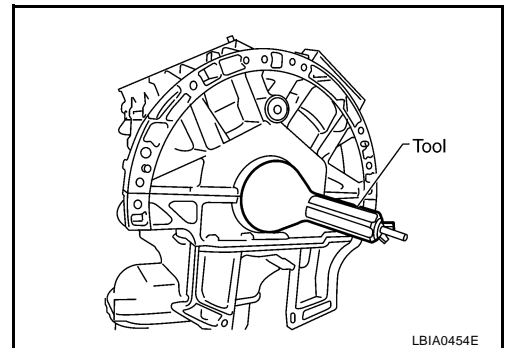

3. Installation of the remaining components is in the reverse order of removal.

CYLINDER HEAD

PF11041

CYLINDER HEAD

On-Vehicle Service

EBS00PS0

CHECKING COMPRESSION PRESSURE

1. Run the engine until it reaches normal operating temperature.
2. Turn the ignition switch to OFF.
3. Release fuel pressure and leave the fuel pump electrically disconnected. Refer to [EC-82, "FUEL PRESSURE RELEASE"](#).
4. Remove all six spark plugs. Refer to [EM-38, "Removal and Installation"](#).
5. Attach a compression tester to No. 1 cylinder.
6. Depress accelerator pedal fully to keep the electric throttle control actuator butterfly-valve wide open to maximize air intake flow.
7. Crank the engine and record the highest gauge indication.
8. Repeat the measurement on each cylinder (steps 5 - 7).

NOTE:

Always use a fully-charged battery to obtain specified engine speed.

Unit: kPa (kg/cm², psi)/300 rpm

Standard	Minimum	Difference limit between cylinders
1,275 (13.0, 185)	981 (10.0, 142)	98 (1.0, 14)

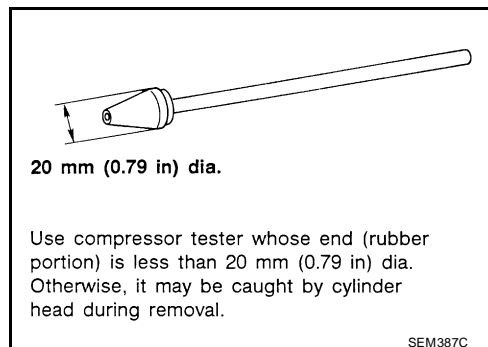

9. If compression in one or more cylinders is low:
 - a. Pour a small amount of engine oil into cylinders through the spark plug holes.
 - b. Retest compression (steps 5 - 8).
 - If adding oil helps raise compression pressure, then the piston rings may be worn or damaged. If so, replace piston rings after checking piston.
 - If the pressure stays low, a valve may be sticking or is seating improperly. Inspect and repair the valve and/or valve seat. Refer to [EM-146, "VALVE"](#). If the valve and/or valve seat is damaged excessively, replace as necessary.
 - If compression stays low in two or more cylinders that are next to each other:
 - The cylinder head gasket may be leaking.
 - Both cylinders may have valve component damage. Inspect and repair as necessary.
10. After inspection is complete, install removed components.
11. Start engine and confirm that engine runs smoothly.
12. Perform trouble diagnosis. If DTC appears, erase it. Refer to [EC-86, "TROUBLE DIAGNOSIS"](#).

CYLINDER HEAD

Removal and Installation

EBS00PS1

SEC. 111•118•130•140•220

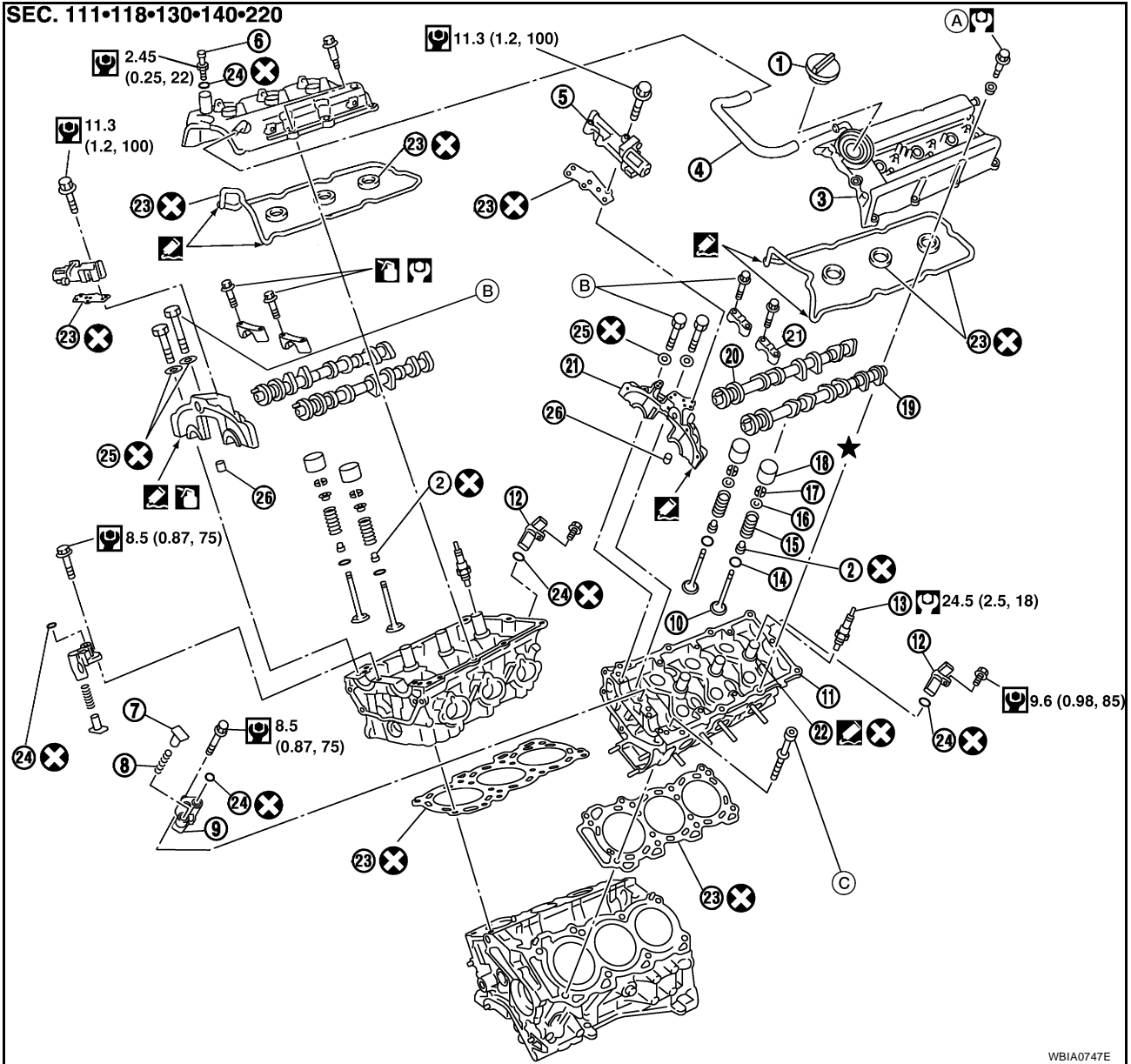

- | | | |
|-----------------------------------|-----------------------------------|--------------------------------------|
| 1. Oil filler cap | 2. Oil seal | 3. Rocker cover |
| 4. PCV hose | 5. IVT control solenoid valve | 6. PCV valve |
| 7. Tensioner sleeve | 8. Spring | 9. Secondary timing chain tensioner |
| 10. Valve | 11. Cylinder head | 12. Camshaft position sensor (PHASE) |
| 13. Spark plug | 14. Valve spring seat | 15. Valve spring |
| 16. Valve spring retainer | 17. Valve collet | 18. Valve lifter |
| 19. Camshaft (EXH) | 20. Camshaft (INT) | 21. Camshaft bracket |
| 22. Spark plug tube | 23. Gasket | 24. O-ring |
| 25. Seal washer | 26. Dowel pin | ☆ Selectable parts |
| A. Refer to EM-44 | B. Refer to EM-82 | C. Refer to EM-99 |

REMOVAL

1. Remove the intake manifold. Refer to [EM-24, "REMOVAL"](#) .
2. Remove the timing chains. Refer to [EM-56, "Removal and Installation"](#) .
3. Remove the three way catalysts (manifolds), exhaust manifold heat shields and RH exhaust manifold. Refer to [EM-26, "Removal and Installation"](#) .

CYLINDER HEAD

4. Remove the intake and exhaust camshafts and the camshaft brackets.

- Mark the camshaft brackets so they are placed in the same position and direction for installation.
- Equally loosen the camshaft bracket bolts in several steps in the order as shown.

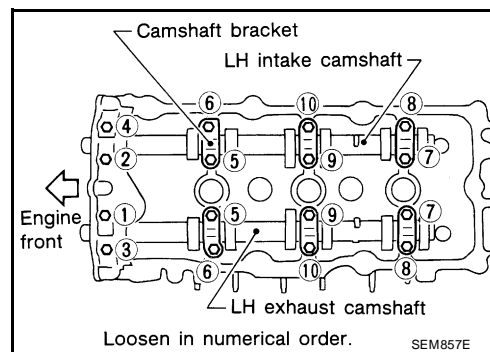
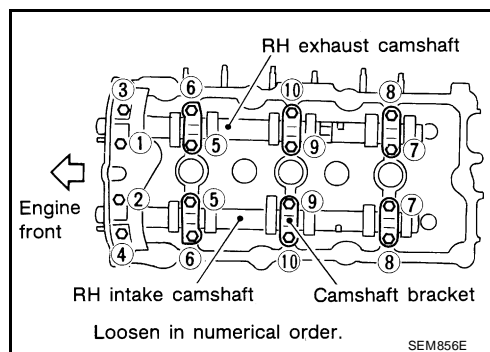

5. Remove the water outlet. Refer to [CO-25, "REMOVAL"](#).
6. Remove the RH and LH cylinder head bolts, using power tool.
- The bolts should be loosened gradually in three steps in the order as shown.

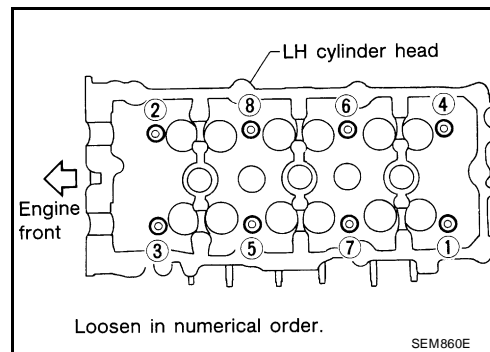
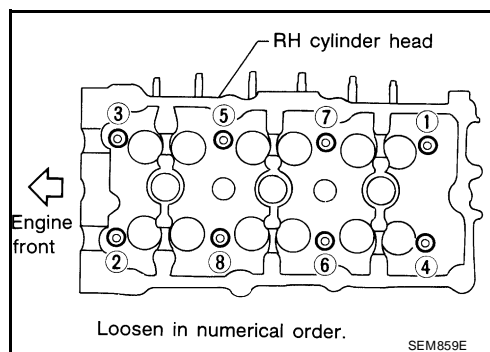

7. Remove cylinder heads and gaskets.
- Discard the cylinder head gaskets and use new gaskets for installation.

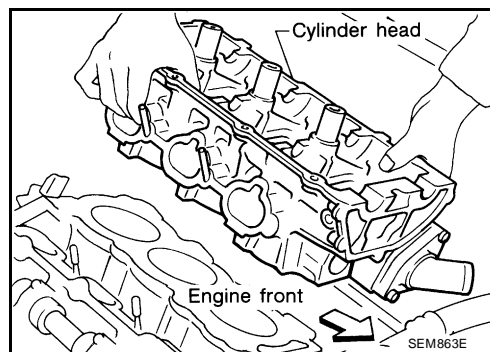

CYLINDER HEAD

- If necessary, remove the LH exhaust manifold. Loosen the exhaust manifold nuts in the order as shown.

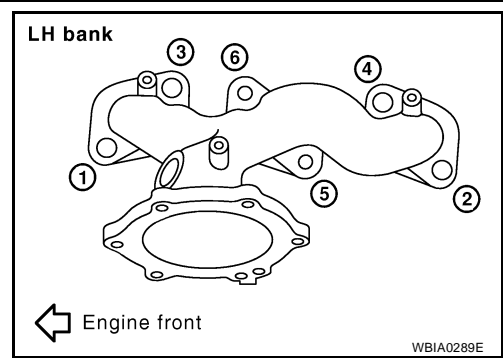

INSPECTION AFTER REMOVAL

Outer Diameter of Cylinder Head Bolts

- Inspect the cylinder head bolts before installing the cylinder heads.

CAUTION:

Cylinder head bolts are tightened by degree rotation tightening method. Whenever the size difference between d1 and d2 exceeds the limit, replace the bolts with new ones.

Limit (d1 - d2) : 0.11 mm (0.0043 in)

- If a reduction in outer diameter appears in a position other than d2, use it as the d2 measuring point.
- Lubricate threads and seat surfaces of the bolts with new engine oil for installation.

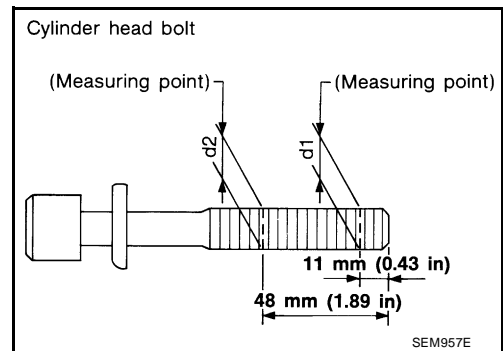

INSTALLATION

- Before installing the rear timing chain case, remove the old Silicone RTV Sealant from mating surface using a scraper.

- Also remove old sealant from mating surface of cylinder block.

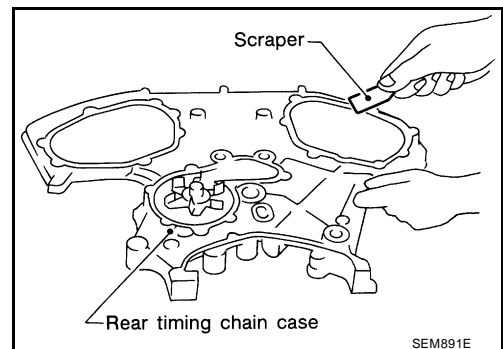

- Remove the old Silicone RTV Sealant from the bolt hole and thread.

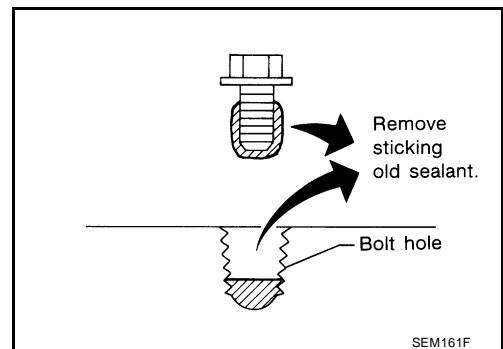

CYLINDER HEAD

- Before installing the No. 1 camshaft bracket, remove the old Silicone RTV Sealant from the mating surface using a scraper.
 - Do not scratch the mating surface.

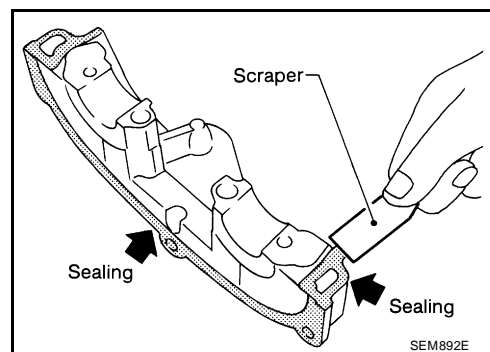

- Turn the crankshaft until No. 1 piston is set at TDC on the compression stroke.
 - The crankshaft key should line up with the right bank cylinder center line as shown.

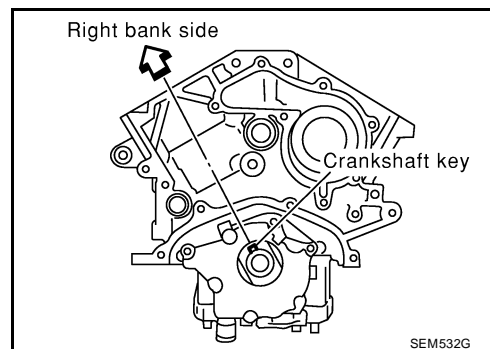

- Install new gaskets on the cylinder heads.

CAUTION:

Do not rotate crankshaft and camshaft separately or valves will strike piston heads.

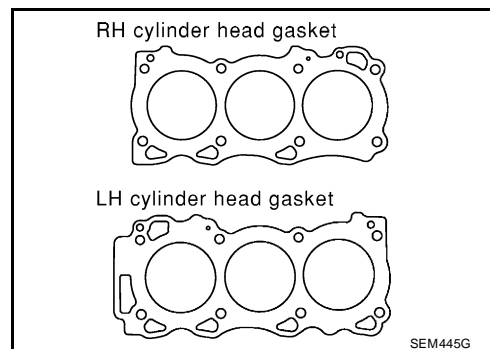

- If necessary, install the LH exhaust manifold. Tighten the exhaust manifold nuts in the order as shown.

Exhaust manifold nuts : 30.9 N·m (3.2 kg-m, 23 ft - lb)

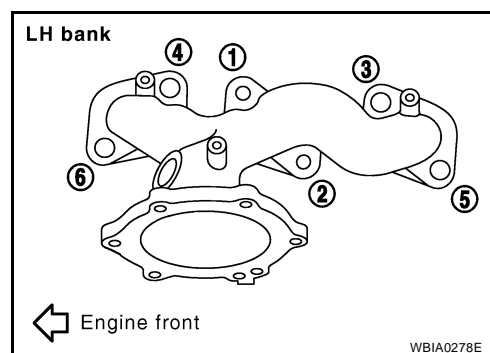

- Install the cylinder heads on the cylinder block. Tighten the cylinder head bolts in five steps in the order as shown using Tool.

Tool number : KV10112100 (BT-8653-A)

Step a : 98 N·m (10 kg-m, 72 ft-lb)

Step b : Loosen in the reverse order of tightening.

Step c : 39.2 N·m (4.0 kg-m, 29 ft-lb)

Step d : 90° clockwise

Step e : 90° clockwise

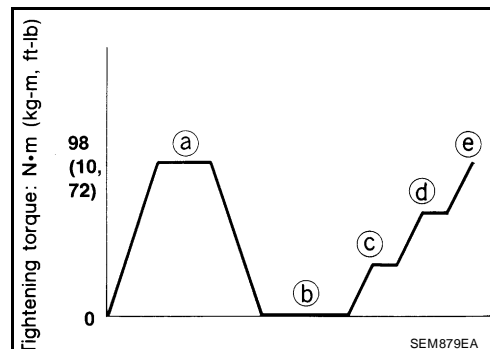

CYLINDER HEAD

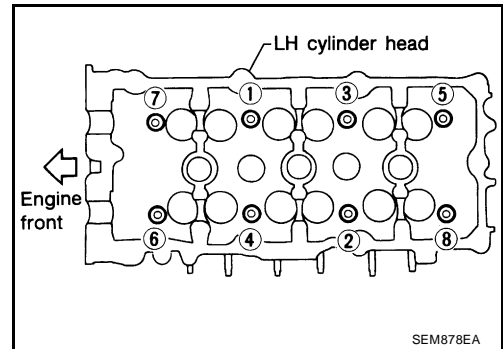
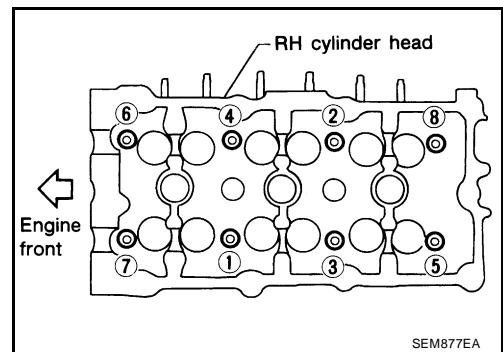

7. Install the water outlet. Refer to [CO-25, "INSTALLATION"](#) .
8. Install secondary timing chain tensioners (3) on both RH (1) and LH (2) cylinder heads.
 - O-rings (4)
 - Stopper pin (5)

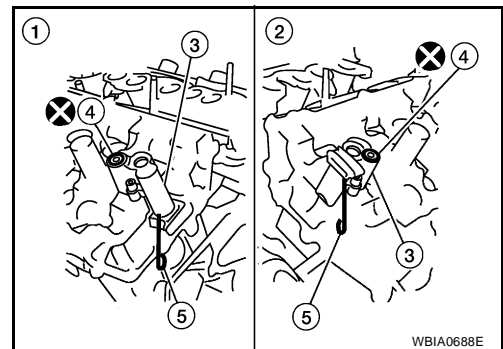

9. Install exhaust and intake camshafts and camshaft brackets.
 - Intake camshaft has a drill mark on camshaft sprocket mounting flange.

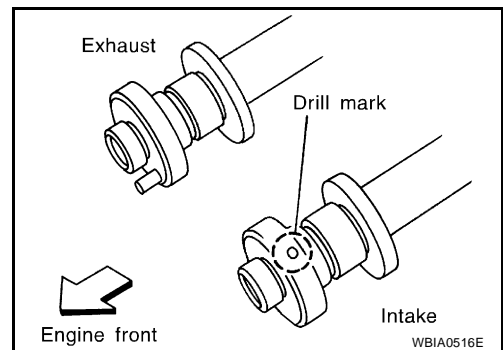

CYLINDER HEAD

- Follow your identification marks made during removal, or follow the identification marks that are present on the new camshaft components for proper placement.
 ← Indicates engine front.

Bank	INT/EXH	Identification mark	Drill mark	Paint marks	
				M1 (3)	M2 (2)
RH (4)	INT	RE	Yes	Yes	No
	EXH	RE	No	No	Yes
LH (5)	INT	LH	Yes	Yes	No
	EXH	LH	No	No	Yes

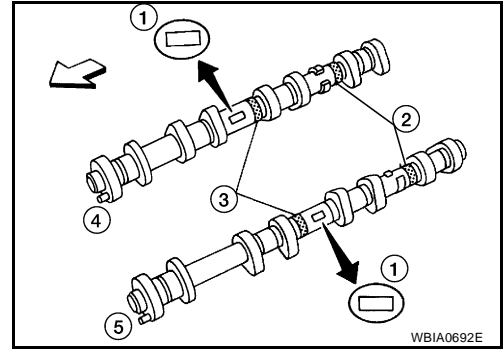

- Position the camshafts:
 RH exhaust camshaft dowel pin at about 10 o'clock
 LH exhaust camshaft dowel pin at about 2 o'clock.

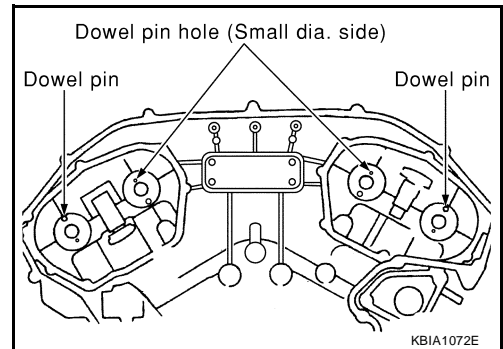

10. Before installing No. 1 camshaft bracket, apply sealant to mating surface.

- Use Genuine Silicone RTV Sealant, or equivalent. Refer to [GI-46, "RECOMMENDED CHEMICAL PRODUCTS AND SEALANTS"](#).

Camshaft No.1 bracket

SEPARATE 5 (0.20) 2 (0.08) 8.5 (0.335)

SEPARATE 5 (0.20)
 Sealing diameter
 2.0 - 3.0 (0.08 - 0.12)

* : Remove the protruding sealant from front face. (Remove the hardened sealant from surface only.)

☑ : Apply Genuine RTV Silicone Sealant or equivalent. Refer to GI section.

Unit: mm (in)

CYLINDER HEAD

- Before installation, wipe off any protruding sealant.
- Refer to [EM-5, "Precautions for Liquid Gasket"](#) .

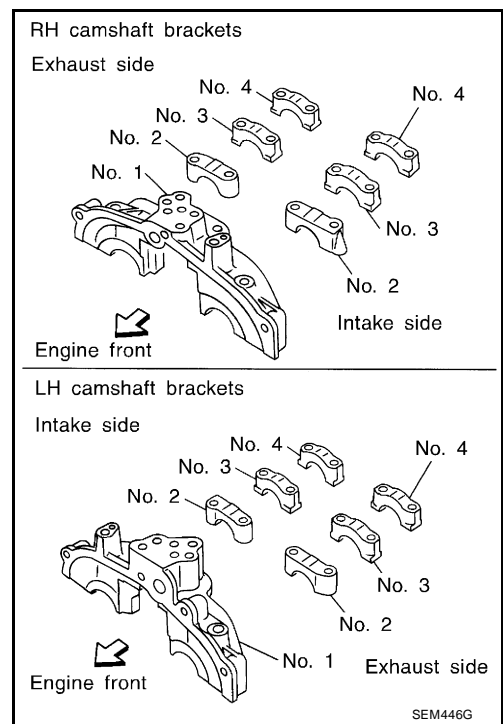

- Install No. 2 and 4 camshaft brackets in their original positions and directions. Align the stamp marks as shown.
- If any part of the valve assembly or camshaft is replaced, check and adjust the valve clearance. Refer to [EM-87, "Valve Clearance"](#) .

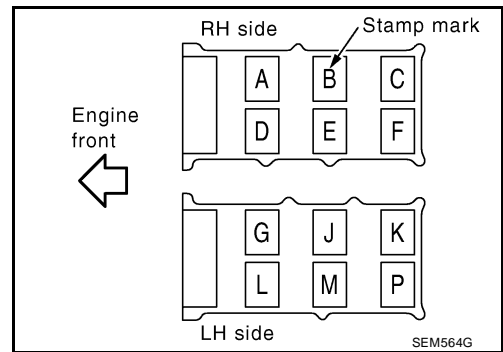

11. Tighten the camshaft brackets in four steps in the order as shown.

NOTE:

Lubricate the threads and seat surfaces of the camshaft bracket bolts with new engine oil before installation.

Camshaft bracket bolts

Step 1 (bolts 7 - 10) : 1.96 N-m (0.2 kg-m, 17 in-lb)

Step 2 (bolts 1 - 6) : 1.96 N-m (0.2 kg-m, 17 in-lb)

Step 3 : 5.88 N-m (0.6 kg-m, 52 in-lb)

Step 4 : 10.4 N-m (1.1 kg-m, 92 in-lb)

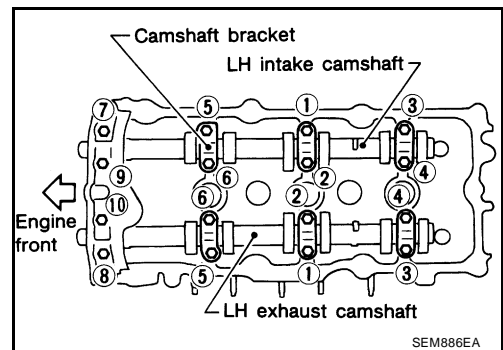
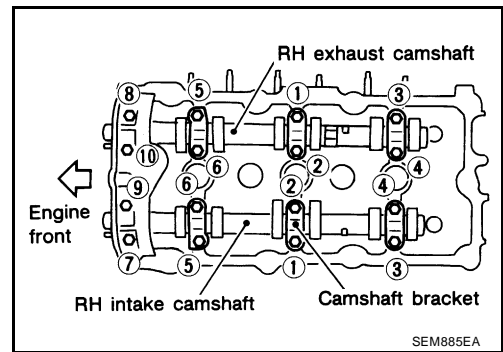

CYLINDER HEAD

12. Measure difference in levels between front end faces of camshaft No. 1 bracket and cylinder head.

Standard : — 0.14 mm (–0.0055 in)

NOTE:

If measurement is outside the specific range, re-install camshaft and camshaft bracket.

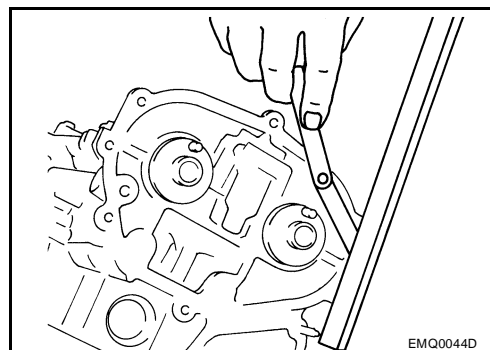

13. Install the IVT control solenoid valves with new gaskets.

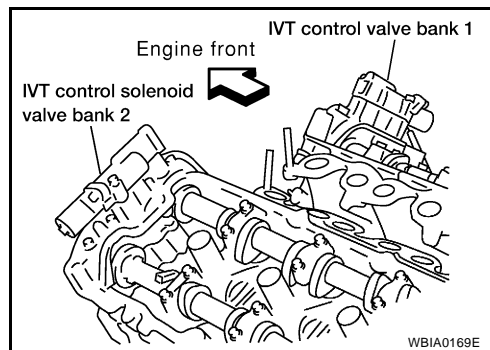

14. Install new O-rings on the cylinder block.

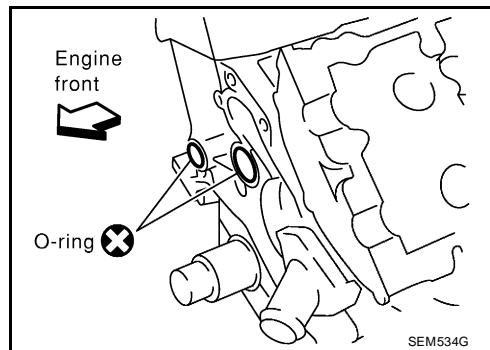

15. Install RH (1) and LH (2) new O-rings (3) on the cylinder heads.

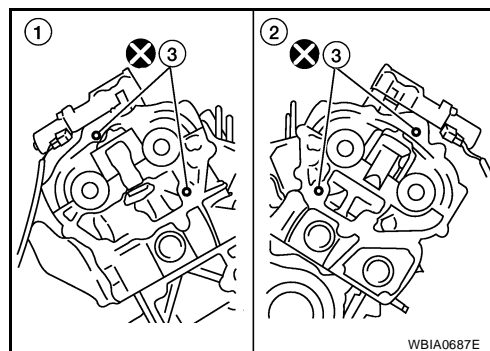

16. Install the RH exhaust manifold, three way catalysts (manifolds) and exhaust manifold heat shields. Refer to [EM-26, "Removal and Installation"](#) .
17. Install timing chain. Refer to [EM-56, "Removal and Installation"](#) .
18. Install the intake manifold. Refer to [EM-25, "INSTALLATION"](#) .

CYLINDER HEAD

Disassembly and Assembly

EBS00PS2

SEC. 111•140

A

EM

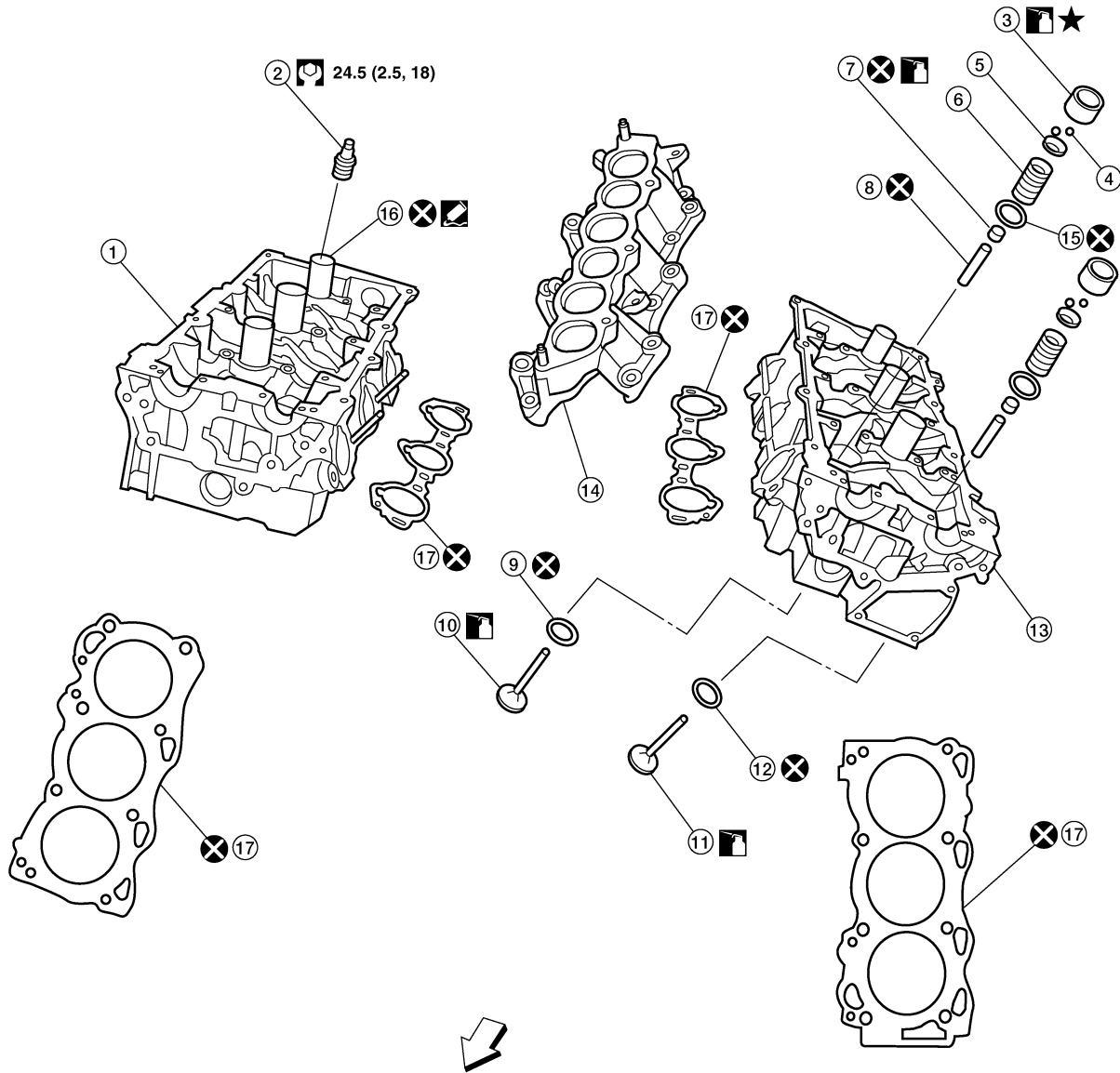

C

D

E

F

G

H

I

J

K

L

M

- 1. Cylinder head (right bank)
- 4. Valve collet
- 7. Valve oil seal
- 10. Valve (INT)
- 13. Cylinder head (left bank)
- 16. Spark plug tube

- 2. Spark plug
- 5. Valve spring retainer
- 8. Valve guide
- 9. Valve seat (INT)
- 11. Valve (EXH)
- 12. Valve seat (EXH)
- 14. Intake manifold
- 17. Gaskets

- 3. Valve lifter
- 6. Valve spring
- 15. Valve spring seat
- ⇒ Engine front

WBIA0693E

CYLINDER HEAD

CAUTION:

- When installing camshafts, chain tensioners, oil seals, or other sliding parts, lubricate contacting surfaces with new engine oil.
- Apply new engine oil to threads and seat surface when installing cylinder head, camshaft sprocket, crankshaft pulley, and camshaft bracket.
- Attach tags to valve lifters so as not to mix them up.

DISASSEMBLY

1. Remove valve lifter.
 - Mark position for installation.
2. Remove valve collet.
 - Compress valve spring using Tool. Remove valve collet with magnet driver.

Tool numbers : KV10116200 (J-26336-B)
: KV10115900 (J-26336-20)
: KV10109230 (—)

3. Remove valve spring retainer, valve spring, and valve spring seat.
4. Push valve stem to combustion chamber side, and remove valve, mark for assembly.

- Inspect valve guide clearance before removal. Refer to [EM-107, "VALVE GUIDE CLEARANCE"](#).
- Confirm installation point.

5. Remove the valve oil seals using Tool.

Tool number : KV10107902 (J-38959)

6. If valve seat must be replaced, refer to [EM-109, "VALVE SEAT REPLACEMENT"](#).
7. If valve guide must be replaced, refer to [EM-108, "VALVE GUIDE REPLACEMENT"](#).
8. Remove spark plug with spark plug wrench.
9. Remove spark plug tube, as necessary.
 - Using a pair of pliers, pull spark plug tube out of cylinder head.

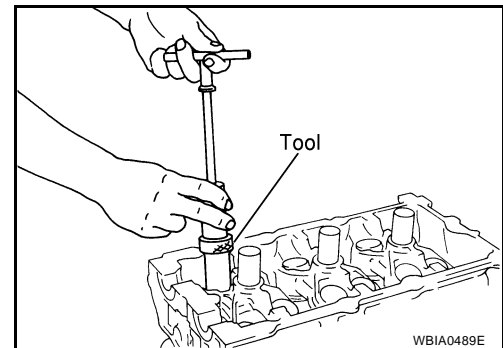
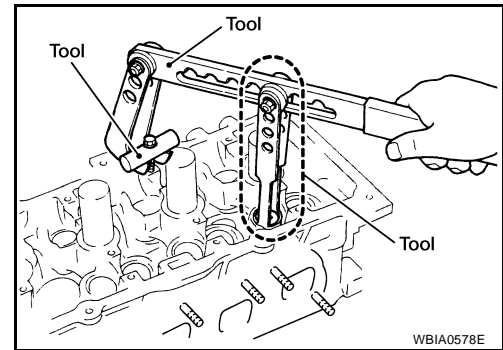

CAUTION:

- Be careful not to damage cylinder head.
- Once removed, a spark plug tube will be deformed and cannot be reused. Do not remove it unless absolutely necessary.

CYLINDER HEAD

EBS00PS3

Inspection After Disassembly CYLINDER HEAD DISTORTION

- Clean the surface of the cylinder head. Use a reliable straightedge and feeler gauge to check the flatness of cylinder head surface.
- Check along six positions as shown.

Head surface distortion

Limit : 0.1 mm (0.004 in)

- If beyond the specified limit, resurface or replace it.
- The limit for cylinder head resurfacing is determined by the cylinder block resurfacing.

Resurfacing Limit

Amount of cylinder head resurfacing is "A".

Amount of cylinder block resurfacing is "B".

The maximum limit : $A + B = 0.2 \text{ mm (0.008 in)}$

- After resurfacing cylinder head, check that camshaft rotates freely by hand. If resistance is felt, cylinder head must be replaced.

Nominal cylinder head height "H" : 126.3 - 126.5 mm (4.972 - 4.980 in)

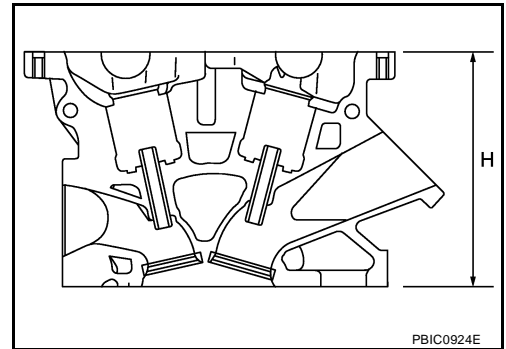
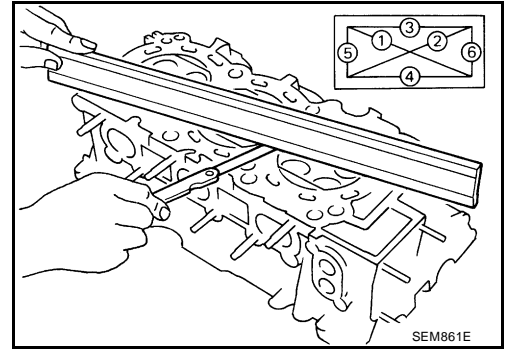

VALVE DIMENSIONS

Check dimensions of each valve, refer to [EM-146, "Valve Dimensions"](#).

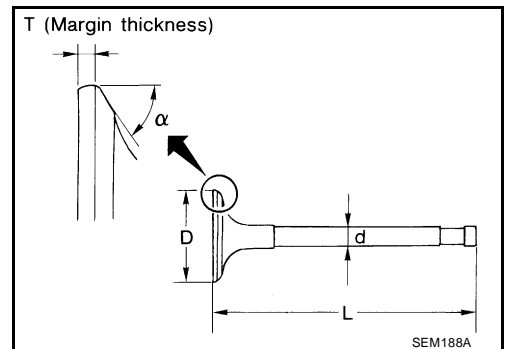

VALVE GUIDE CLEARANCE

1. Measure valve deflection as shown. (Valve and valve guide mostly wear in this direction.)

Valve deflection limit (dial gauge reading)

Intake : 0.24 mm (0.0094 in)

Exhaust : 0.28 mm (0.0110 in)

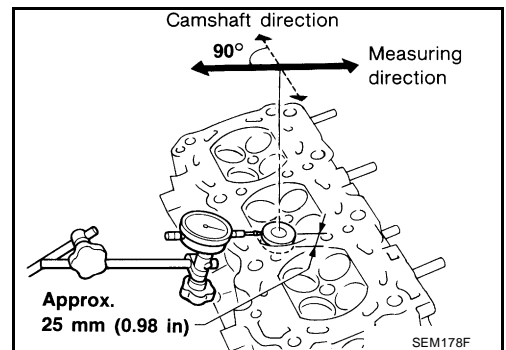

CYLINDER HEAD

2. If it exceeds the limit, check valve to valve guide clearance.
 - a. Measure valve stem diameter and valve guide inner diameter.
 - b. Check that clearance is within specification.

Valve to valve guide clearance standard

Intake : 0.020 - 0.053 mm (0.0008 - 0.0021 in)

Exhaust : 0.030 - 0.063 mm (0.0012 - 0.0025 in)

Valve to valve guide clearance limit

Intake : 0.08 mm (0.0031 in)

Exhaust : 0.09 mm (0.0035 in)

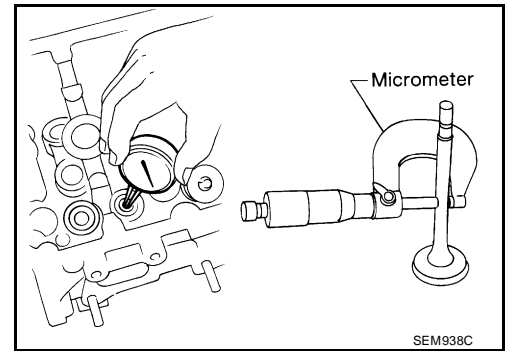

- c. If it exceeds the limit, replace valve or valve guide.

VALVE GUIDE REPLACEMENT

NOTE:

When valve guide is removed, replace with oversized [0.2 mm (0.008 in)] valve guide.

1. To remove valve guide, heat cylinder head to 110° - 130°C (230° - 266°F) by soaking in heated oil.

WARNING:

Cylinder head is hot. Wear protective equipment to prevent getting burned.

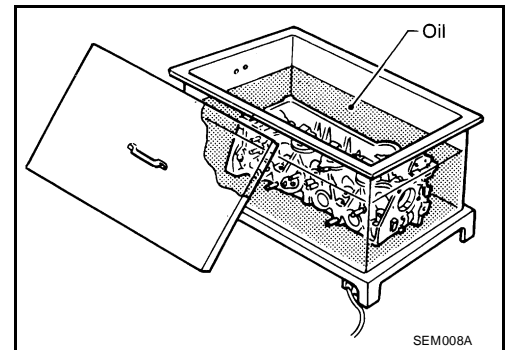

2. Drive out the valve guide with a press [under a 20 kn (2.2 US ton) pressure] or hammer and suitable tool.

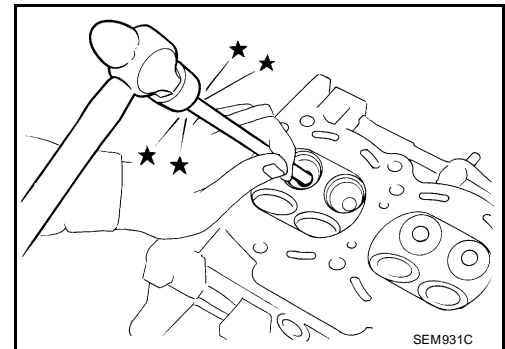

3. Ream cylinder head valve guide hole using suitable reamer.

Valve guide hole diameter : 10.175 - 10.196 mm
(for service parts), intake (0.4006 - 0.4014 in)
and exhaust

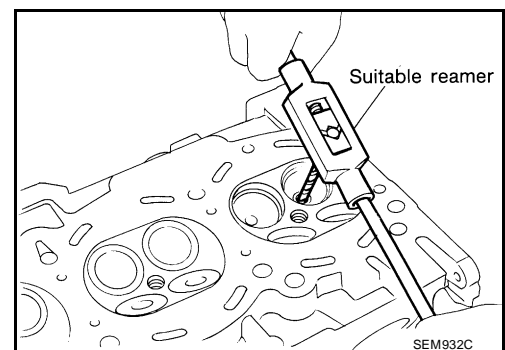

CYLINDER HEAD

- Heat cylinder head to 110° - 130°C (230° - 266°F) by soaking in heated oil and press new valve guide from camshaft side into the cylinder head to the dimensions as shown.

WARNING:

Cylinder head is hot. Wear protective equipment to prevent getting burned.

Projection "L" : 12.6 - 12.8 mm (0.496 - 0.504 in)

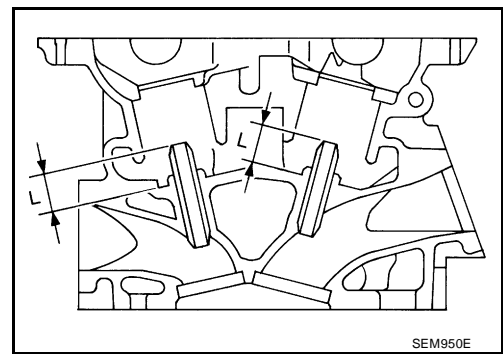

- Apply a reamer finish to the valve guide, using suitable reamer.

Intake and exhaust finished size : 6.000 - 6.018 mm (0.2362 - 0.2369 in)

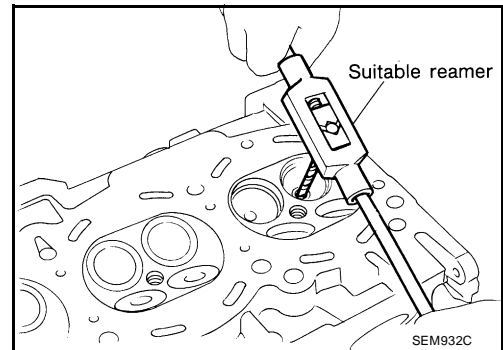

VALVE SEAT CONTACT

- After confirming that the dimensions of valve guides and valves are within specifications, perform this procedure.
- Apply prussian blue onto contacting surface of valve seat to check the condition of the valve contact on the surface.
- Check if the contact area band is continuous all around the circumference.
- If not, grind to adjust valve fitting and check again. If the contacting surface still has N.G conditions even after the re-check, replace valve seat.

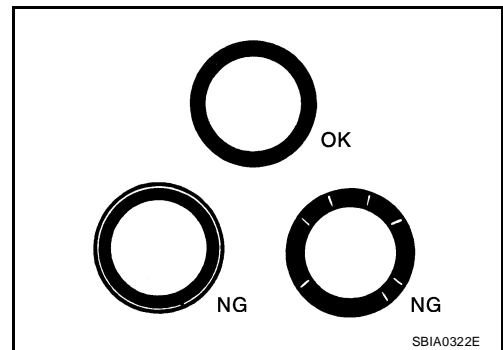

VALVE SEAT REPLACEMENT

- Bore out old seat until it collapses. Boring should not continue beyond the bottom face of the seat recess in cylinder head. Set the machine depth stop to ensure this.
- Ream cylinder head recess for service valve seat.

Oversize : 0.5 mm (0.020 in)

Intake : 38.500 - 38.516 mm (1.5157 - 1.5164 in)

Exhaust : 32.700 - 32.716 mm (1.2874 - 1.2880 in)

- Be sure to ream in circles concentric to the valve guide center.
- This will enable valve seat to fit correctly.

- Heat cylinder head to 110° - 130°C (230° - 266°F) by soaking in heated oil.

WARNING:

Cylinder head is hot. Wear protective equipment to prevent getting burned.

- Press fit valve seat until it seats on the bottom.
- Cut or grind valve seat using suitable tool to the specified dimensions. Refer to [EM-146, "VALVE"](#).
- After cutting, lap valve seat with abrasive compound.
- Check valve seating condition.

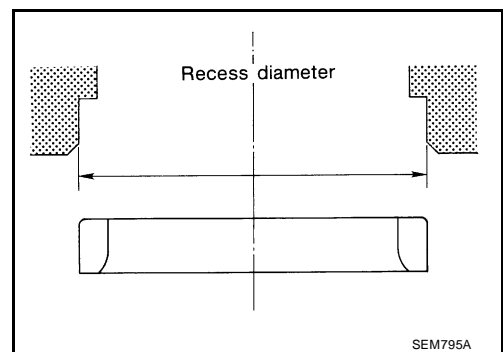

CYLINDER HEAD

Seat face angle " α "	: 45° 25' - 46° 15' degrees/minutes (45.42° - 46.25° degree decimal)
Contacting width " W " for intake	: 1.09 - 1.31 mm (0.043 - 0.052 in)
Contacting width " W " for exhaust	: 1.29 - 1.51 mm (0.051 - 0.059 in)

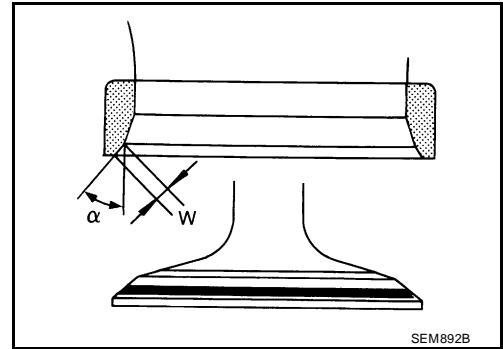

8. Use a depth gauge to measure the distance between the mounting surface of the cylinder head spring seat and the valve stem end. If the distance is shorter than specified, repeat step 5 to adjust it. If it is longer, replace the valve seat with a new one.

Valve seat resurface limit " L " intake	: 41.07 - 41.67 mm (1.6169 - 1.6405 in)
Valve seat resurface limit " L " exhaust	: 41.00 - 41.60 mm (1.6142 - 1.6378 in)

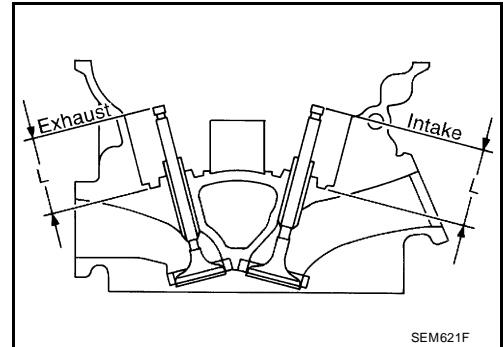

VALVE SPRING SQUARENESS

Set try square along the side of valve spring and rotate the spring. Measure the maximum clearance between the top face of spring and try square.

Out-of-square limit : Less than 2.0 mm (0.079 in)

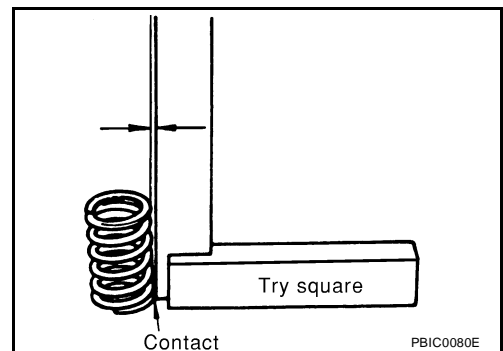

VALVE SPRING DIMENSIONS AND VALVE SPRING PRESSURE LOAD

Check valve spring pressure at specified spring height.

Standard	: 166 - 188 N (16.9 - 19.2 kg, 37.3 - 42.3 lb) at height 37.0 mm (1.457 in)
Limit	: 378 - 426 N (38.6 - 43.5 kg, 85.0 - 95.8 lb) at height 27.8 mm (1.094 in)

If it is not within specifications, replace the spring.

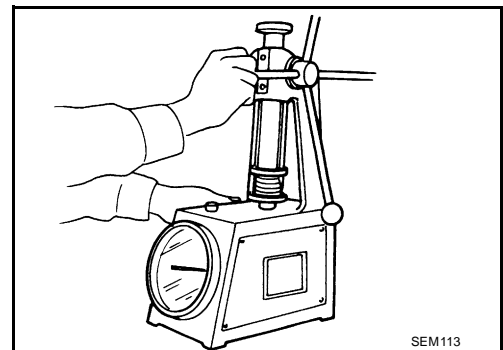

ASSEMBLY

1. Install valve guide. Refer to [EM-108, "VALVE GUIDE REPLACEMENT"](#).
2. Install valve seat. Refer to [EM-109, "VALVE SEAT REPLACEMENT"](#).

CYLINDER HEAD

3. Install new valve spring seats and new valve oil seals using Tool.

Tool number : (J-39386)

- Install with valve oil seal drift to match dimension in illustration.

NOTE:

Dimension "H": Height measured before valve spring seat installation.

Height "H"

Intake and exhaust : 14.3 - 14.9 mm (0.563 - 0.587 in)

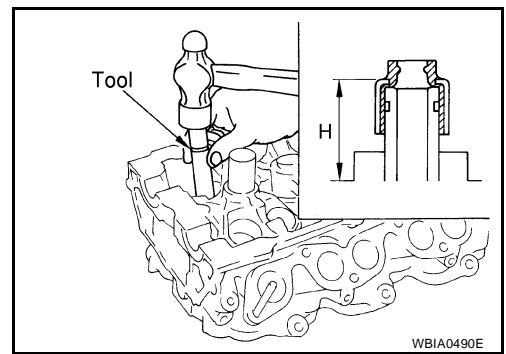

4. Install the valves in their original position, as marked during disassembly.

5. Install valve spring (uneven pitch type).

- Install smaller pitch end (paint mark) to cylinder head side (valve spring seat side).

6. Install valve spring retainer.

Paint mark color **Blue**
 Violet

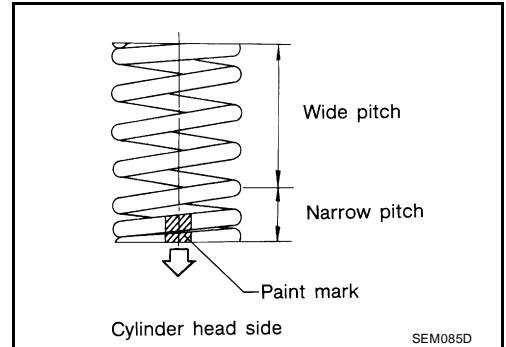

7. Install valve collet.

Tool numbers : KV10116200 (J-26336-B)

: KV10115900 (J-26336-20)

: KV10109230 (—)

- Compress valve spring using Tool and install valve collet.
- Tap stem edge lightly with plastic hammer after installation to check its installed condition.

8. Install valve lifter.

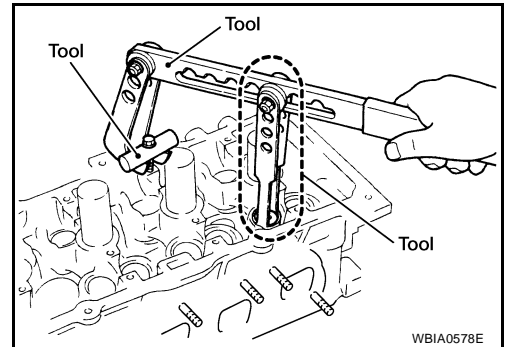

9. Install spark plug tube as follows:

- Remove old liquid gasket from all cylinder head holes.
- Apply liquid gasket to area within approximately 12 mm (0.47 in) from edge of spark plug tube press fit side.
 - Use Genuine RTV Silicone Sealant or equivalent. Refer to [GI-46, "RECOMMENDED CHEMICAL PRODUCTS AND SEALANTS"](#).
- Press fit the spark plug tube so that its height "H" is as specified, using suitable tool.

Standard press fit : 38.55 - 38.65 mm
height "H" : (1.5177 - 1.5217 in)

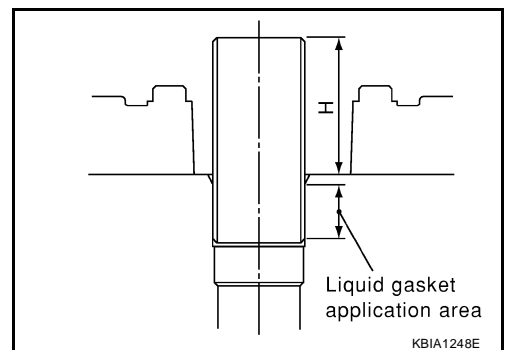

CAUTION:

- When press fitting, take care not to deform spark plug tube.
- After press fitting, wipe off liquid gasket protruding onto cylinder head upper face.

10. Install spark plug with spark plug wrench.

ENGINE ASSEMBLY

ENGINE ASSEMBLY

PF:10001

Removal and Installation

EBS00PS4

Engine mounting

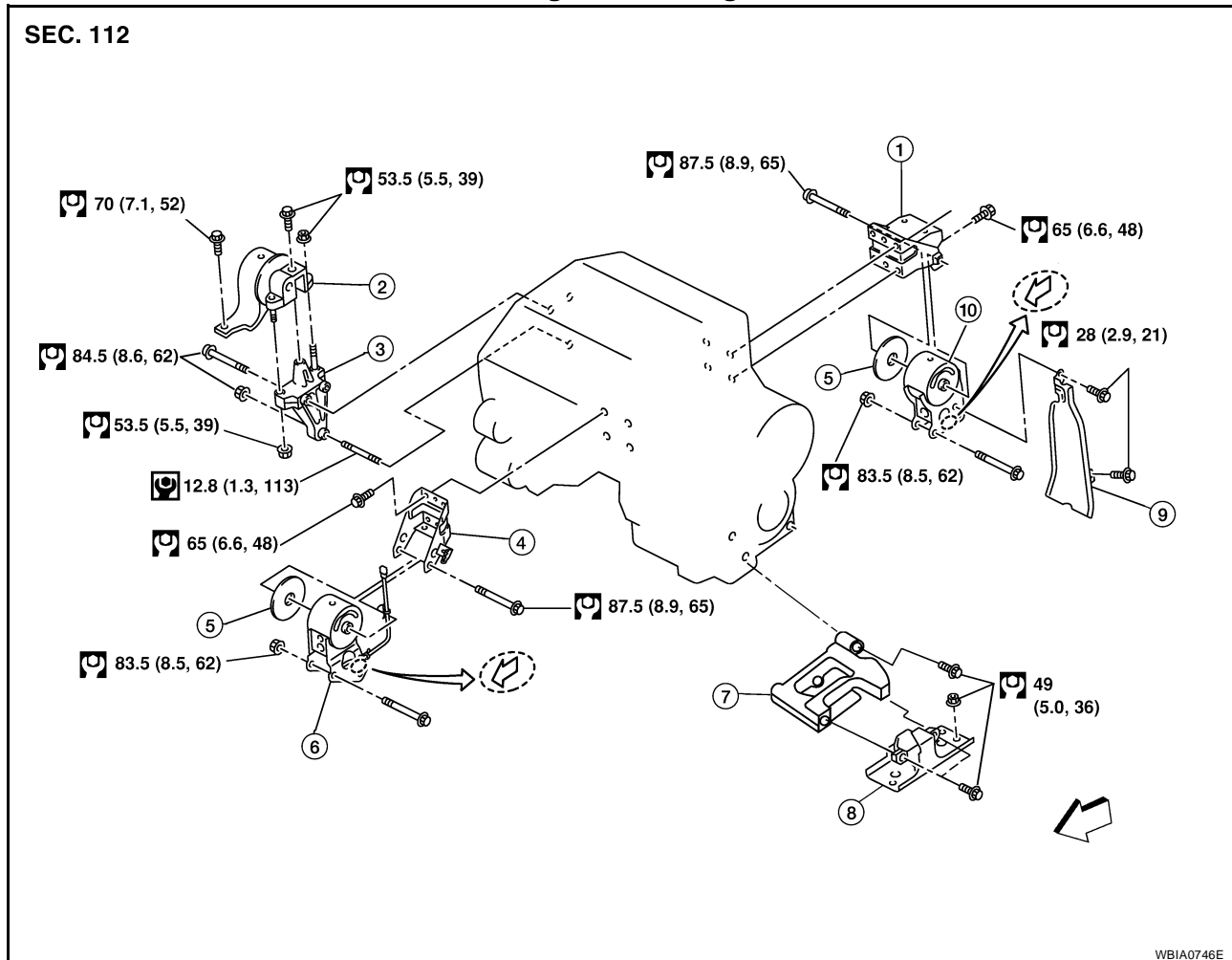

WBIA0746E

- | | | |
|------------------------------------|------------------------------------|------------------------------------|
| 1. Rear engine mounting bracket | 2. RH engine mounting insulator | 3. RH engine mounting bracket |
| 4. Front engine mounting bracket | 5. Stopper | 6. Front engine mounting insulator |
| 7. LH transaxle mounting bracket | 8. LH transaxle mounting insulator | 9. Air guide |
| 10. Rear engine mounting insulator | ← Front | ○ Stamping indication |

ENGINE ASSEMBLY

Front suspension member mounting

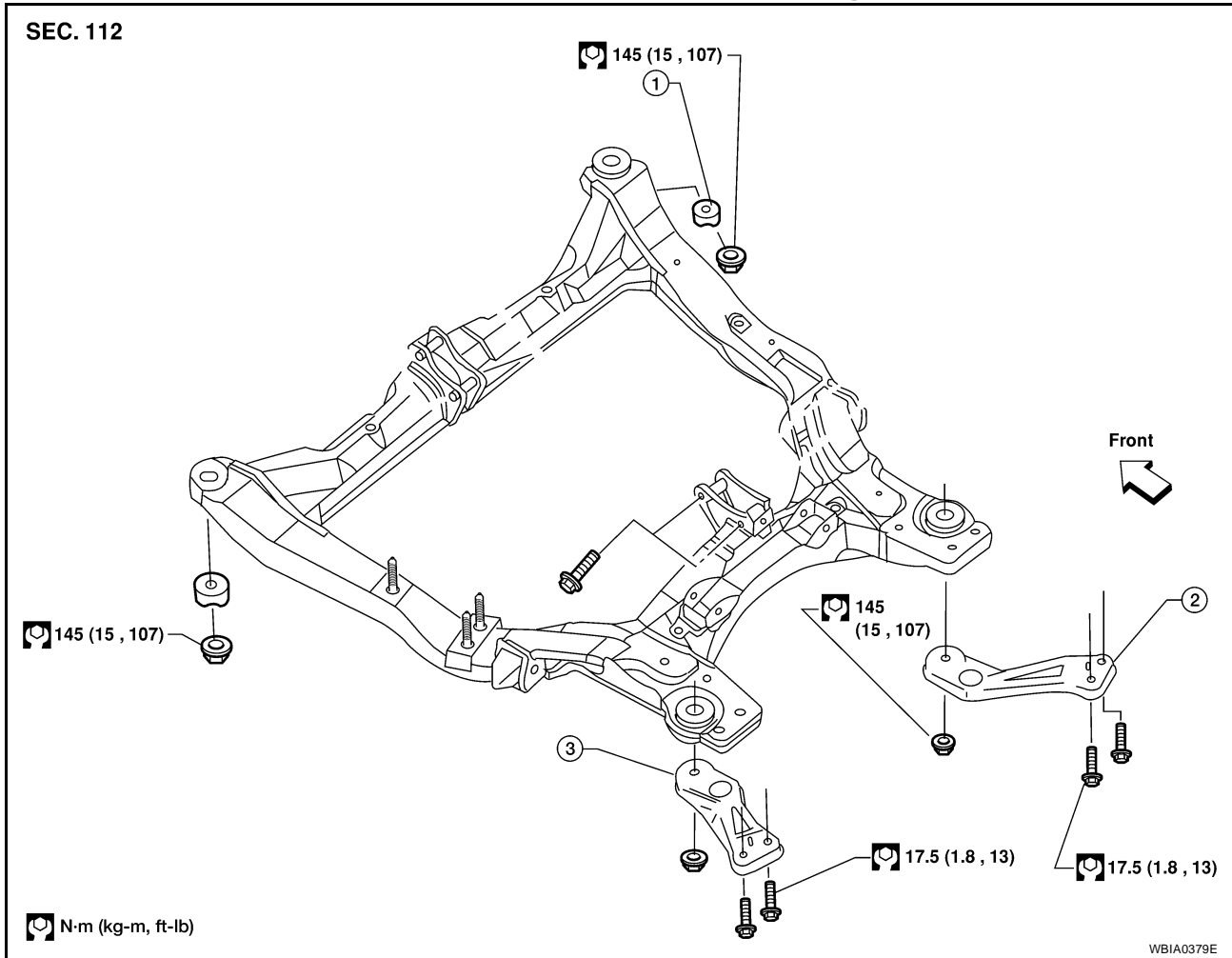

1. Cup

2. Member pin stay, RH

3. Member pin stay, LH

WARNING:

- Place chocks at front and back of rear wheels.
- For engines not equipped with engine slingers, attach proper slingers and bolts as described in the NISSAN Parts Catalog.

CAUTION:

- Do not start working until exhaust system and coolant are cool.
- If items or work required are not covered by the engine section, refer to the applicable sections.
- Use the correct supporting points for lifting and jacking. Refer to [GI-41, "LIFTING POINT"](#).
- In removing the drive shafts, be careful not to damage any transaxle grease seals.
- Before separating the engine and transaxle, remove the crankshaft position sensor (POS).
- Do not damage the edge of the crankshaft position sensor (POS) or the ring gear teeth.

REMOVAL

1. Disconnect battery positive and negative terminals.
2. Drain coolant. Refer to [CO-10, "DRAINING ENGINE COOLANT"](#).
3. Drain A/T fluid. Refer to [MA-24, "Changing A/T Fluid"](#).
4. Remove the cowl top extension. Refer to [EI-19, "Removal and Installation"](#).
5. Disconnect engine room harness from the PCM and the two connections at the RH strut tower. Disconnect engine harness ground connections.
6. Disconnect the mass air flow sensor electrical connector.
7. Remove the fresh air intake tube and air cleaner to electric throttle control actuator tube attached to air cleaner lid. Remove air cleaner case (lower). Refer to [EM-16, "Removal and Installation"](#).

ENGINE ASSEMBLY

8. Remove the engine cover using power tool.
9. Remove the battery and battery tray. Refer to [SC-9, "Removal and Installation"](#) .
10. Release fuel pressure. Refer to [EC-82, "FUEL PRESSURE RELEASE"](#) .
11. Disconnect fuel hose quick connection at vehicle piping side.
 - a. Remove connector cap from the fuel hose.
 - b. Squeeze the two tabs and pull the fuel hose from the fuel line.

NOTE:

If the connector and the tube are stuck together, push and pull several times until they start to move. Then disconnect them by pulling.

CAUTION:

- The tube can be removed when the tabs are completely depressed. Do not twist it more than necessary.
- Do not use any tools to remove the quick connector.
- Keep the resin tube away from heat. Be especially careful when welding near the tube.
- Prevent acid liquids such as battery electrolyte, etc. from getting on the resin tube.
- Do not bend or twist the tube during removal or installation.
- Do not remove the remaining retainer on the tube.
- When the tube is replaced, also replace the retainer with a new one.
- To keep the connecting portion clean and to avoid damage and foreign materials entering, cover the ends of the fuel tubes with plastic bags or something similar.

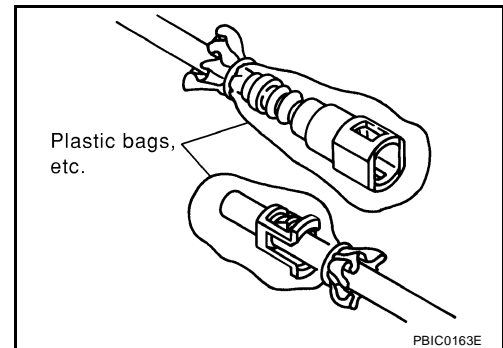
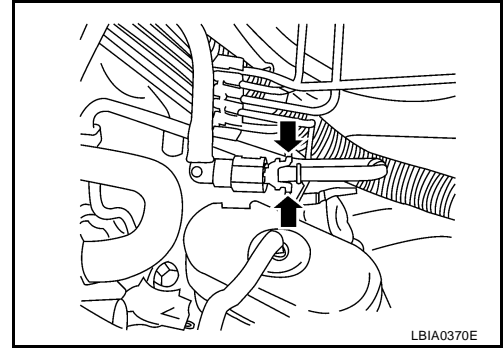

12. Remove the radiator assembly, engine coolant reservoir tank, and system hoses. Refer to [CO-15, "Removal and Installation"](#) .
13. Disconnect the brake booster vacuum hose from the back of the intake manifold collector.
14. Disconnect the EVAP canister purge volume control solenoid valve hose.
15. Disconnect heater hoses at the water outlet and heater pipe.
16. Disconnect the two fusible link connectors at the battery positive terminal.
17. Disconnect two engine harness connectors below mass air flow sensor attached to the strut tower.
18. Disconnect the harness retainers and position the engine harness aside.
19. Remove the ground cable and ground wire from transaxle.
20. Disconnect the transaxle shift controls. Refer to [AT-230, "Removal and Installation"](#) .
21. Remove the drive belts. Refer to [EM-15, "Removal and Installation"](#) .
22. Remove the front exhaust tube and hanger using power tools. Refer to [EX-3, "Removal and Installation"](#) .
23. Remove the front drive shafts. Refer to [FAX-8, "FRONT DRIVE SHAFT"](#) .

ENGINE ASSEMBLY

24. Remove the lower ball joint pinch bolt using power tool, then separate the transverse link from the steering knuckle.
25. Remove the power steering line bracket from the front suspension member.
26. Remove the bolts on the lower side of the steering gear. Refer to [PS-15, "Removal and Installation"](#) .
27. Disconnect the front engine mount electrical connector.

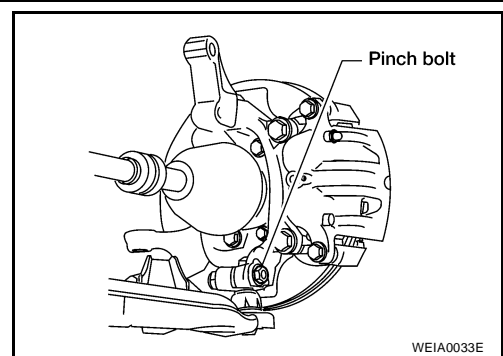

28. Disconnect the connecting rod from the front strut using power tool.

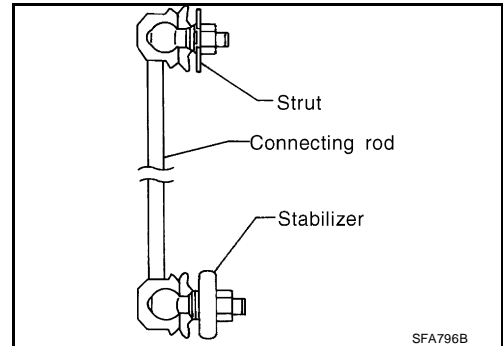

29. Disconnect power steering line brackets from rear engine mounting insulator and rear of lower intake manifold collector.
30. Remove engine oil cooler pipe bolts.
31. Discharge and recover the A/C refrigerant. Refer to [ATC-193, "HFC-134a \(R-134a\) Service Procedure"](#) .
32. Remove A/C low-pressure flexible hose. Refer to [ATC-201, "Removal and Installation for Low-pressure Flexible Hose"](#) (ATC) or [MTC-180, "Removal and Installation for Low-pressure Flexible Hose"](#) (MTC).
33. Remove A/C high-pressure flexible hose. Refer to [ATC-201, "Removal and Installation for High-pressure Flexible Hose"](#) (ATC) or [MTC-180, "Removal and Installation for High-pressure Flexible Hose"](#) (MTC).
34. Remove the A/C compressor using power tools. Refer to [ATC-197, "Removal and Installation for Compressor"](#) .
35. Disconnect transaxle breather hose.
36. Disconnect the power steering pressure switch.
37. Disconnect harness retainer from power steering oil pump bracket.
38. Remove the idler pulley and idler pulley bracket and power steering pump, without disconnecting the piping, from the engine and position and secure it aside. Refer to [PS-22, "Removal and Installation"](#)
39. Remove the crankshaft position sensor (POS).
40. Remove the rear cover plate and bolts securing the torque converter to drive plate

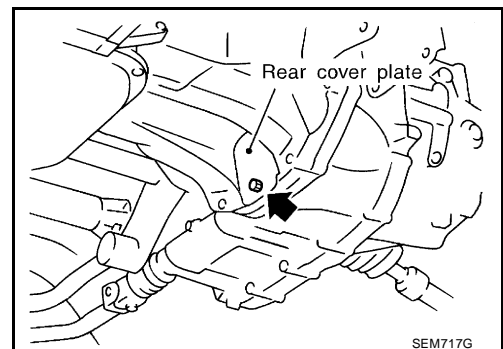

41. Position a transmission jack under the engine/transaxle assembly.
42. Remove the RH engine mounting insulator nuts and bolt.
43. Remove the front suspension member and engine/transaxle assembly as follows:
 - a. Remove the RH and LH member pin stay bolts.

ENGINE ASSEMBLY

- b. Remove the front suspension member nuts and cups and carefully lower the front suspension member and engine/transaxle assembly avoiding interference with the vehicle body.

CAUTION:

- **Make sure to disconnect electrically controlled engine mounting insulator harness clips from the front suspension member prior to removal.**
- **Before and during this procedure, always check if any harnesses are left connected.**
- **Avoid any damage to, or any oil/grease smearing or spills onto the engine mounting insulators.**

44. Remove the starter motor. Refer to [SC-16, "Removal and Installation"](#) .
45. Disconnect the electrical connectors, harness retainers and remove harnesses.
46. Disconnect the ATF cooler hoses and remove the ATF cooler. Refer to [AT-235, "REMOVAL"](#) .
47. Remove the front and rear engine mount through bolts.
48. Remove the LH transaxle mount bolts.
49. Raise the engine/transaxle and remove the front suspension member.
50. Remove the ATF cooler valve from the engine with the hoses attached. Refer to [AT-235, "ATF Cooler"](#) .
51. Separate the engine and transaxle and mount the engine on a suitable engine stand.

INSTALLATION

Installation is in the reverse order of removal.

When installing the transaxle to the engine, use the specified tightening torque in the numerical sequence as shown.

Bolt No.	1	2	3	4	5	6	7	8	9
Tightening torque N·m (kg·m, ft·lb)	74.5 (7.6, 55)					41.5 (4.2, 31)			

- Install converter to drive plate bolts.

**Converter to drive : 54 N·m (5.5 kg·m, 40 ft·lb)
plate bolts 5 A/T**

NOTE:

With converter installed, rotate crankshaft several turns to check that transaxle rotates freely without binding.

- Install rear cover plate.

Rear cover plate bolt : 6.91 N·m (0.70 kg·m, 61 in·lb)

- Install crankshaft position sensor (POS).

**Crankshaft position : 9.6 N·m (0.98 kg·m,
sensor (POS) bolt 85 in·lb)**

- Tighten the front suspension member nuts and bolts to specification. Refer to [EM-112, "Removal and Installation"](#) .
- Install the stabilizer bar bushings and clamps in the specified orientation. Refer to [FSU-11, "Removal and Installation"](#) .
- Tighten the stabilizer bar and connecting rod nuts and bolts to specification. Refer to [FSU-5, "Components"](#) .
- Tighten the steering gear bolts to specification. Refer to [PS-15, "Removal and Installation"](#) .

INSPECTION AFTER INSTALLATION

- Before starting engine, check oil/fluid levels including engine coolant and engine oil. If less than required quantity, fill to the specified level. Refer to [GI-46, "RECOMMENDED CHEMICAL PRODUCTS AND SEALANTS"](#) .
- Use procedure below to check for fuel leakage.
- Turn ignition switch ON (with engine stopped). With fuel pressure applied to fuel piping, check for fuel leakage at connection points.
- Start engine. With engine speed increased, check again for fuel leakage at connection points.
- Run engine to check for unusual noise and vibration.

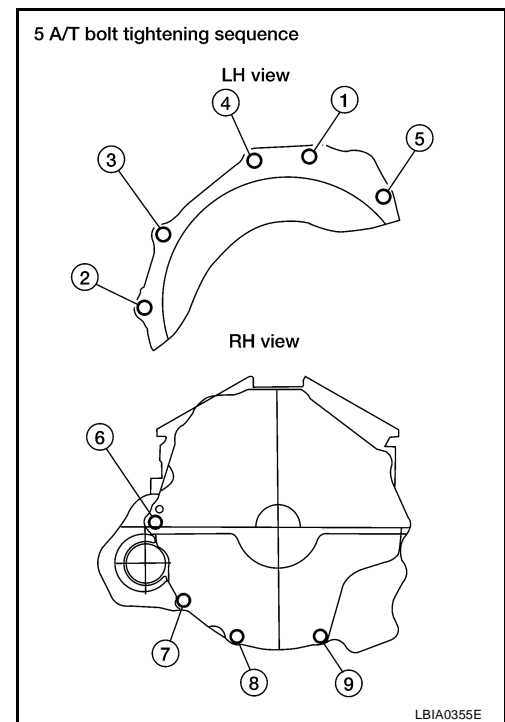

ENGINE ASSEMBLY

- Warm up engine thoroughly to make sure there is no leakage of Fuel, exhaust gas, or any oils/fluids including engine oil and engine coolant.
- Bleed air from passages in lines and hoses, such as in cooling system.
- After cooling down engine, again check oil/fluid levels including engine oil and engine coolant. Refill to specified level, if necessary.
- Summary of the inspection items:

Item	Before starting engine	Engine running	After engine stopped
Engine coolant	Level	Leakage	Level
Engine oil	Level	Leakage	Level
Other oils and fluids*	Level	Leakage	Level
Fuel	Leakage	Leakage	Leakage
Exhaust gas	—	Leakage	—

*Transmission/transaxle/CVT fluid, power steering fluid, brake fluid, etc.

A

EM

C

D

E

F

G

H

I

J

K

L

M

CYLINDER BLOCK

PF11010

CYLINDER BLOCK

Disassembly and Assembly

EBS00PS5

SEC. 110•120•226

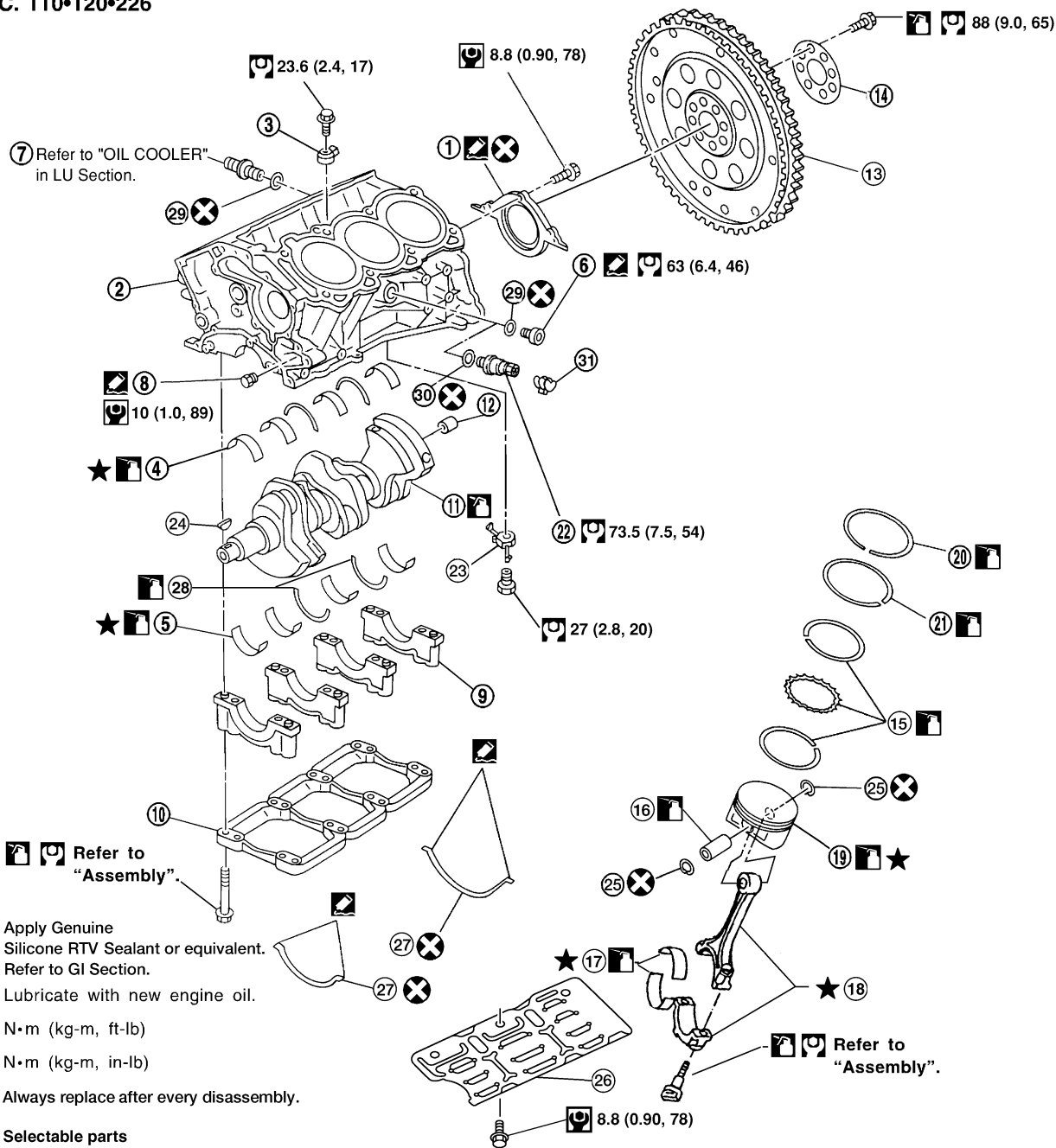

WBIA0552E

- | | | |
|---|---------------------------------------|-------------------------------|
| 1. Rear oil seal retainer | 2. Cylinder block | 3. Knock sensor |
| 4. Upper main bearing | 5. Lower main bearing | 6. Water drain plug (LH side) |
| 7. Water connector (RH side) | 8. Water drain plug (water pump side) | 9. Main bearing cap |
| 10. Main bearing beam | 11. Crankshaft | 12. Pilot converter |
| 13. Drive plate with signal plate | 14. Drive plate reinforcement | 15. Oil ring set |
| 16. Piston pin | 17. Connecting rod bearing | 18. Connecting rod |
| 19. Piston | 20. Top ring | 21. Second ring |
| 22. Cylinder block heater (Canada only) | 23. Oil jet | 24. Key |
| 25. Snap ring | 26. Baffle plate | 27. Gasket |
| 28. Thrust bearing | 29. Gasket | 30. O-ring |
| 31. Connector protector cap | | |

CYLINDER BLOCK

CAUTION:

- Apply new engine oil to parts as marked in illustrations before installation.
- Place removed parts such as bearings and bearing caps in their proper order and direction.
- When installing the connecting rod nuts, and main bearing cap bolts, apply new engine oil to the threads and mating surfaces
- Do not allow any magnetic materials to contact the signal plate teeth on the drive plate.

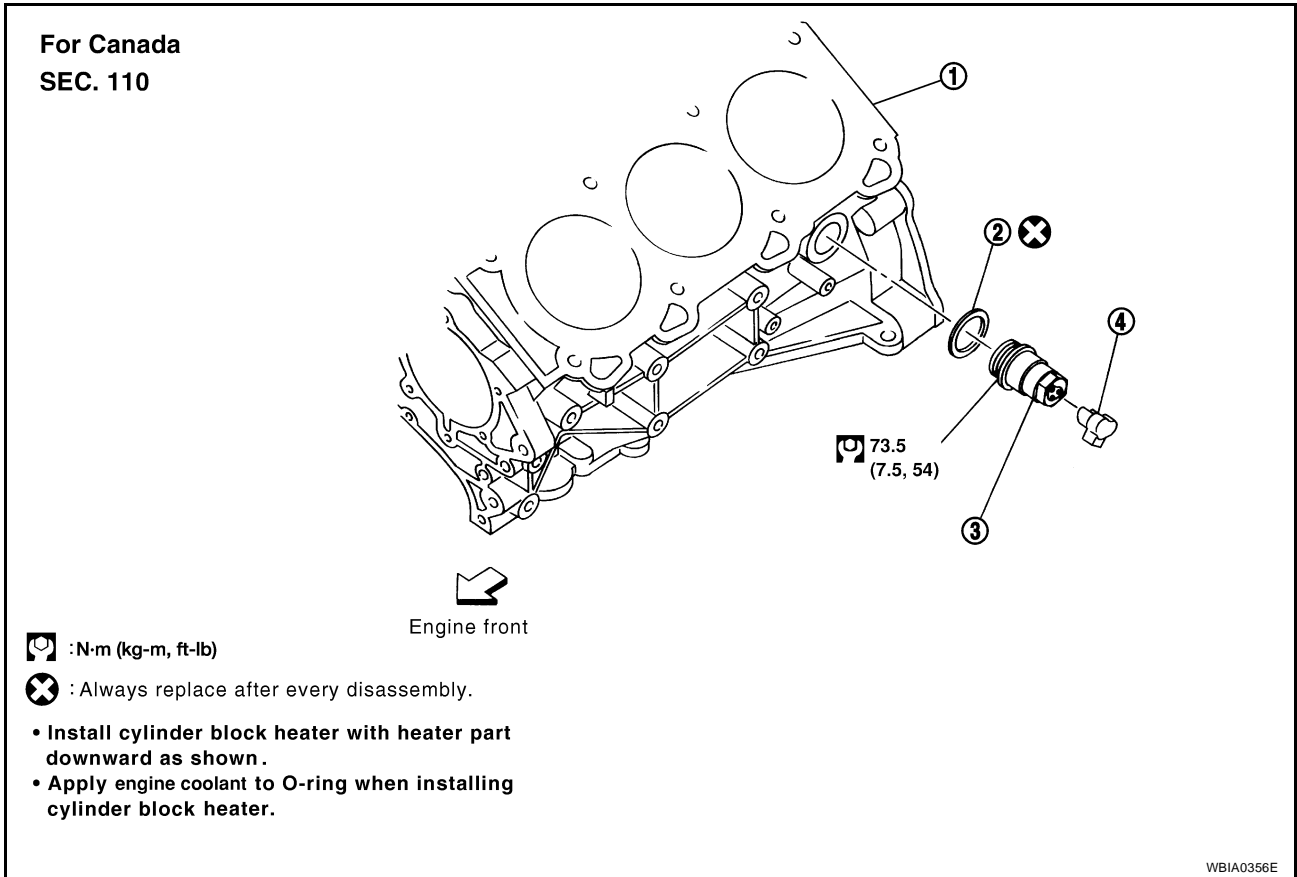

- | | | |
|----------------------------|-----------|--------------------------|
| 1. Cylinder block | 2. O-ring | 3. Cylinder block heater |
| 4. Connector protector cap | | |

DISASSEMBLY

1. Remove the engine assembly. Refer to [EM-112, "ENGINE ASSEMBLY"](#).
2. Lift engine and mount it on Tool.
 - A commercial engine stand can be used.

CAUTION:

Use an engine stand that has a load capacity of approximately 220kg (441 lb) or more.

NOTE:

This example is an engine stand for holding at the transaxle mounting side with the drive plate removed.

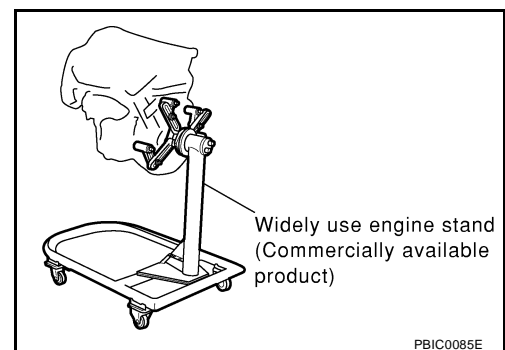

CYLINDER BLOCK

3. Remove the knock sensor.

CAUTION:

Carefully handle sensor avoiding shocking it.

4. Drain the engine of all coolant and oil.
5. Remove the lower and upper oil pans. Refer to [EM-30, "REMOVAL"](#).
6. Remove the timing chain. Refer to [EM-56, "Removal and Installation"](#).
7. Remove oil pump. Refer to [LU-12, "REMOVAL"](#).
8. Remove the cylinder heads. Refer to [EM-97, "REMOVAL"](#).
9. Lock crankshaft using Tool, and remove drive plate bolts.
- Loosen the bolts in diagonal order.

Tool number : KV10117700 (J-44716)

CAUTION:

- Do not disassemble drive plate.
- Never place the drive plate with signal plate facing down.
- When handling signal plate, take care not to damage or scratch it.
- Handle signal plate in a manner that prevents it from becoming magnetized.

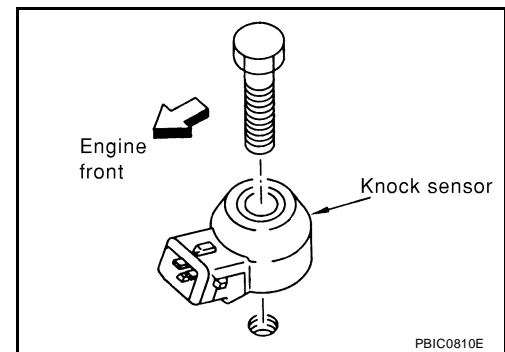

10. Remove pilot converter using Tool.

Tool number : ST16610001 (J-23907)

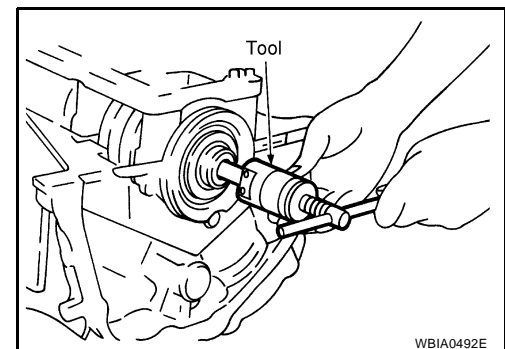

11. Cut away liquid gasket using Tool and remove rear oil seal retainer. Refer to [EM-5, "REMOVAL OF LIQUID GASKET SEALING"](#).

Tool number : KV10111100 (J-37228)

CAUTION:

- Be careful not to damage mounting surface.
- If rear oil seal retainer is removed, replace it with a new one.

NOTE:

Rear oil seal and retainer form a single part and are handled as an assembly.

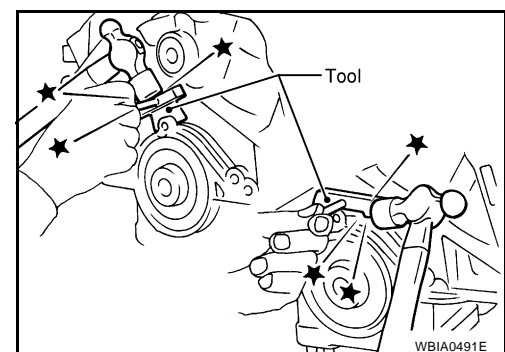

12. Remove baffle plate from main bearing beam.
13. Remove the piston and connecting rod assemblies.
- a. Position the crankshaft pin corresponding to the connecting rod to be removed onto the bottom dead center.
b. Remove the connecting rod cap.
c. Using a hammer handle or similar tool, push the piston and connecting rod assembly out to the cylinder head side.
- Before removing the piston and connecting rod assembly, check the connecting rod side clearance. Refer to [EM-152, "CONNECTING ROD"](#).

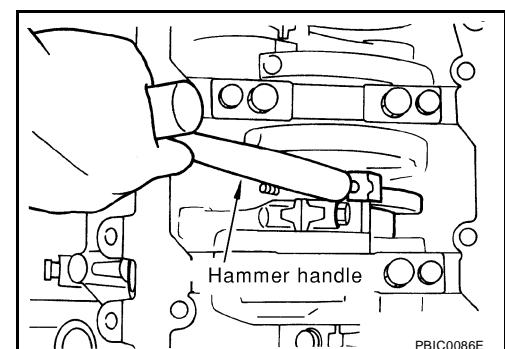

CYLINDER BLOCK

14. Remove the connecting rod bearings.

CAUTION:

- When removing the connecting rod side bearings, note the installation position. Keep them in the correct order.

15. Remove the piston rings from the piston.

- Use a piston ring expander.
- Before removing the piston rings, check the piston ring side clearance. Refer to [EM-135, "PISTON RING SIDE CLEARANCE"](#).

CAUTION:

- When removing the piston rings, be careful not to damage the piston. Do not expand the rings excessively.
- Be careful to mark the rings if they are to be reused so they are installed in their original position.

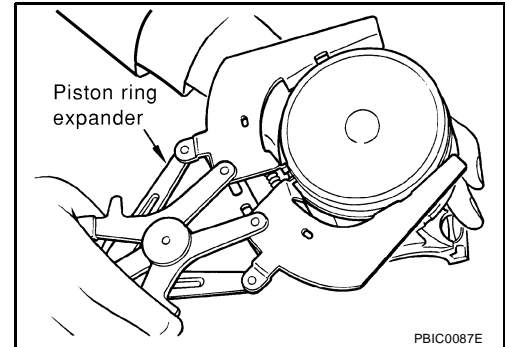

16. Remove the piston from the connecting rod as follows.

a. Remove the snap ring, using suitable snap ring pliers.

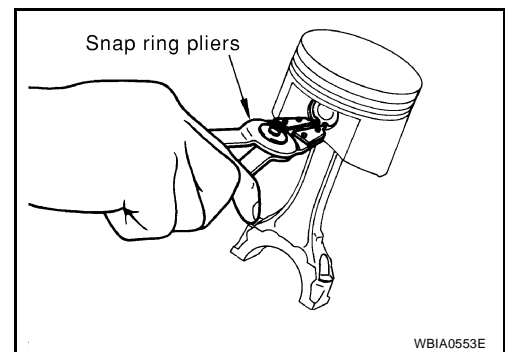

b. Heat the pistons to 60° - 70°C (140° - 158°F).

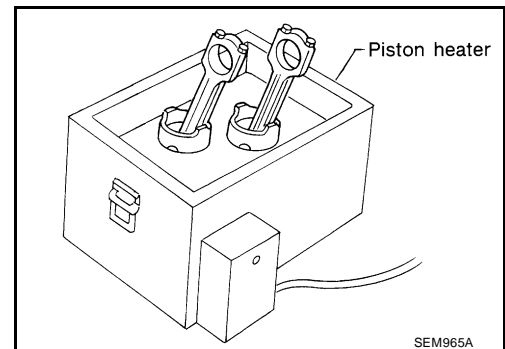

c. Push out the piston pin using a suitable tool, with an outer diameter approximately 20 mm (0.8 in).

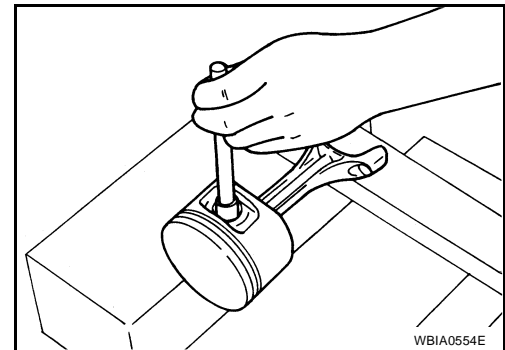

A

EM

C

D

E

F

G

H

I

J

K

L

M

CYLINDER BLOCK

17. Loosen the main bearing cap bolts as shown and remove the main bearing beam, bearing caps and crankshaft.
- Before loosening the main bearing cap bolts, measure the crankshaft side clearance. Refer to [EM-140, "OUT-OF-ROUND AND TAPER OF CRANKSHAFT"](#).

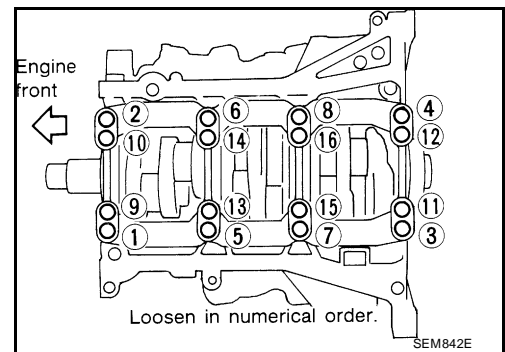

18. Remove the oil jets.
19. Remove the main bearings and thrust bearings from the cylinder block and main bearing caps.

CAUTION:
When removing them, note their direction and position.
Keep them in the correct order for installation.

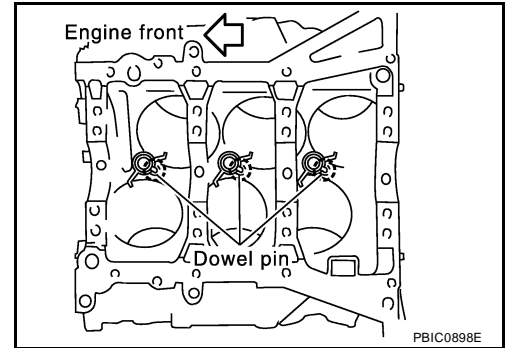

ASSEMBLY

1. Blow out the coolant and oil passages and cylinder bore to remove any foreign materials.

WARNING:
Use goggles to protect your eyes.

2. Apply liquid gasket and install each plug into the cylinder block.
- Use Genuine Silicone RTV Sealant or equivalent. Refer to [GI-46, "RECOMMENDED CHEMICAL PRODUCTS AND SEALANTS"](#).
3. Install the oil jets.
- Insert the oil jet dowel pin into the cylinder block dowel pin hole, and tighten the oil jet bolts.

Oil jet bolts : 27 N-m (2.8 kg-m, 20 ft-lb)

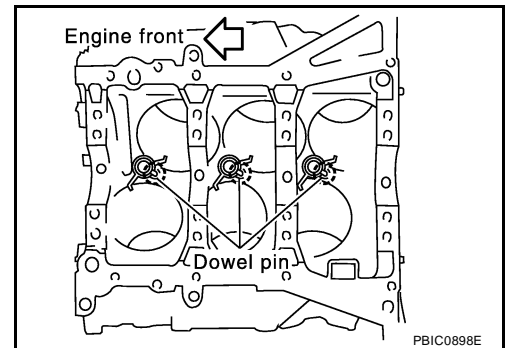

4. Install the main bearings and the thrust bearings.
- a. Remove dust, dirt, and oil on the bearing mating surfaces of the cylinder block and the main bearing cap.
- b. Install the thrust bearings to both sides of the No. 3 journal housing on the cylinder block and the main bearing cap.
- Install the thrust bearings with the oil groove facing the crankshaft arm (outside).
 - Install bearing with a projection on one end on cylinder block and bearing with a projection at center on cap. Align each projection with mating notch.

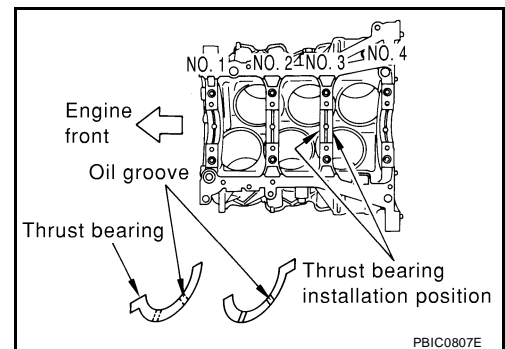

CYLINDER BLOCK

5. Set the upper main bearings in their proper positions on the cylinder block.

- Confirm the correct main bearings are used. Refer to [EM-138](#), "[PISTON-TO-CYLINDER BORE CLEARANCE](#)".

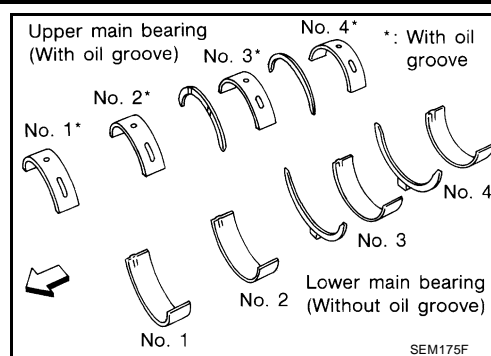

6. Check specifications for the re-use of the main bearing cap bolts.

- Measure d1 and d2 as shown.
- For d2, select the minimum diameter in the measuring area.
- If the difference between d1 and d2 exceeds the limit, replace the bolts for assembly.

Limit (d1 - d2) : 0.11 mm (0.0043 in)

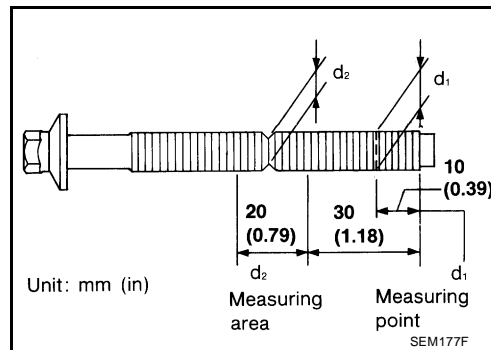

7. After installing the crankshaft, lower main bearings, main bearing caps, main bearing beam, and bearing cap bolts.

- Make sure that the front marks on the main bearing beam faces the front of the engine.
- Prior to tightening all the bearing cap bolts, place the bearing beam in its proper position by shifting the crankshaft in the axial position.
- Lubricate the threads and seat surfaces of the bolts with new engine oil.

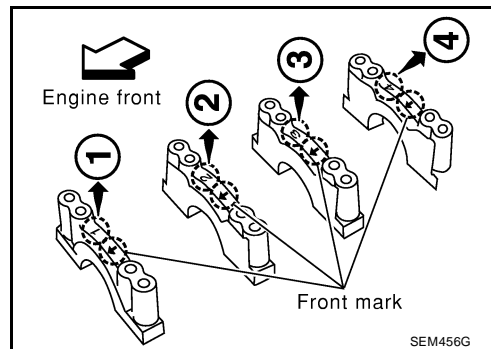

d. Tighten the bearing cap bolts in two steps in the order as shown:

Step 1 : 35 N·m (3.6 kg·m, 26 ft-lb)

Step 2 : 90° - 95° degrees clockwise

CAUTION:

Measure the tighten angle with an angle wrench. Do not measure visually.

Tool number : KV10112100 (BT-8653-A)

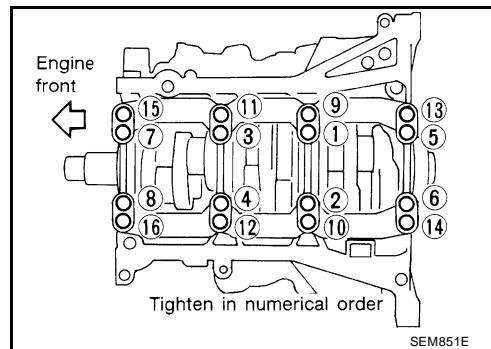

CYLINDER BLOCK

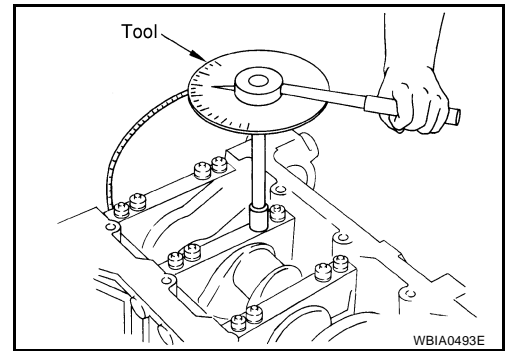

e. After tightening the bearing cap bolts, make sure the crankshaft turns smoothly.

8. Using a dial indicator, measure the clearance between the thrust bearings and the connecting rods when the crankshaft is moved from front to rear.

Standard : 0.10 - 0.25 mm (0.0039 - 0.0098 in)

Limit : 0.30 mm (0.0118 in)

- If beyond the limit, replace the thrust bearings and measure again. If still beyond the limit, replace the crankshaft.

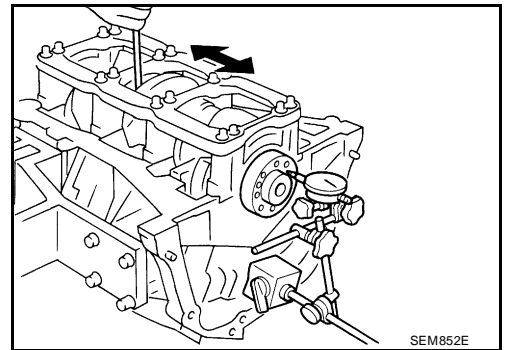

9. Install the rear oil seal retainer.

- Apply sealant to rear oil seal retainer using Tool. Refer to [EM-5, "LIQUID GASKET APPLICATION PROCEDURE"](#) .

Tool number : WS39930000 (—)

- Use Genuine Silicone RTV Sealant, or equivalent. Refer to [GI-46, "RECOMMENDED CHEMICAL PRODUCTS AND SEALANTS"](#) .

Rear oil seal retainer bolts : 8.8 N-m (0.90 kg-m, 78 in-lb)

CAUTION:

Rear oil seal is replaced with the rear oil seal retainer and must be replaced as an assembly.

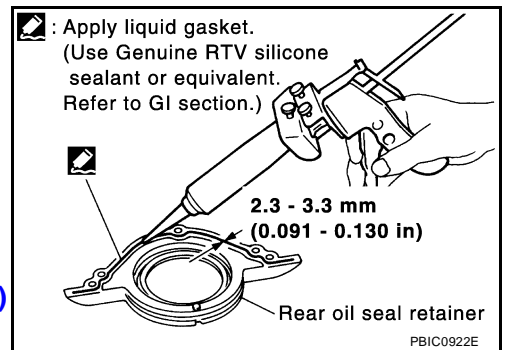

10. Install the piston to the connecting rod.

a. Install the snap ring into the pin-groove of the piston rear side using suitable tool.

- Insert it fully into groove to install.

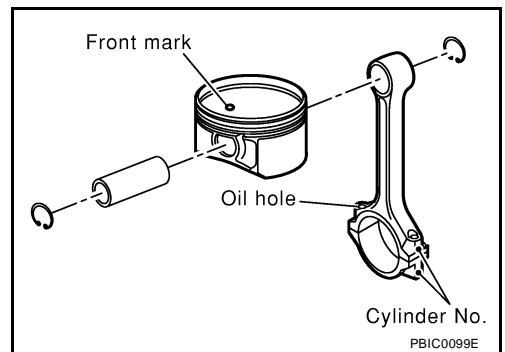

b. Install the piston to the connecting rod.

CYLINDER BLOCK

- Heat the piston until the piston pin can be pushed in by hand without excess force [approx. 60° - 70°C (140° - 158°F)]. From the front to the rear, insert the piston pin into the piston and through the connecting rod.

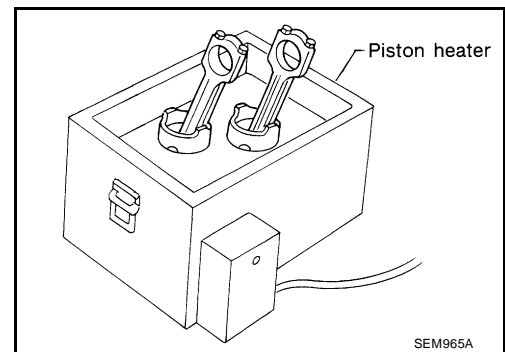

- Assemble so that the front mark on the piston crown and the oil holes and the cylinder No. on the connecting rod are positioned as shown.

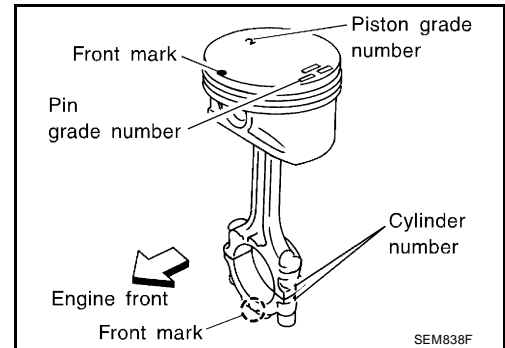

- c. Install the snap ring into the front of the piston pin-groove.
- After installing, check that the connecting rod pivots smoothly on the pin.

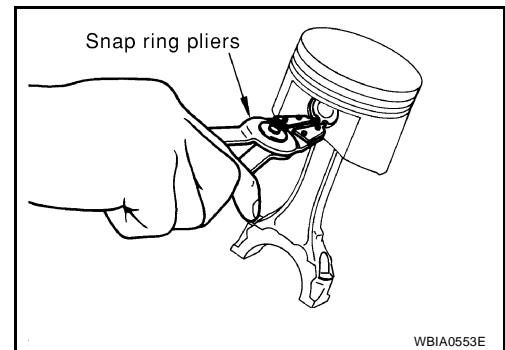

11. Install the piston rings using a piston ring expander.
- Install the top ring and the second ring with the stamped surface facing upward. If the ring is not stamped it can face in either direction.

CAUTION:

- Be careful not to damage the piston.
- When the piston rings are not replaced, remount the rings in their original positions.

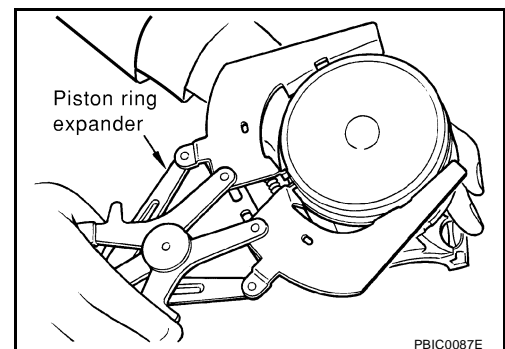

A
EM
C
D
E
F
G
H
I
J
K
L
M

CYLINDER BLOCK

- When replacing the piston rings, those without punch marks can be installed either side up.

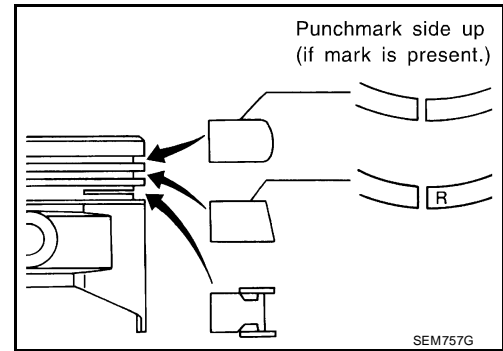

- Position each ring with the gap as shown, referring to the piston front mark.

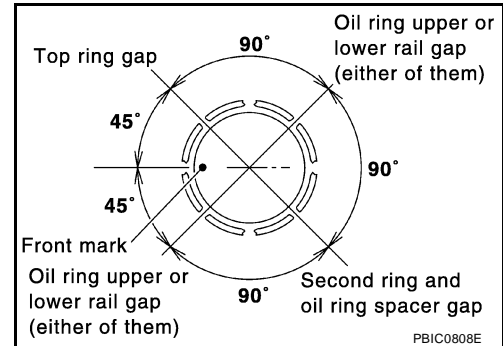

12. Install the connecting rod bearings to the connecting rod and the connecting rod cap.

- When installing the connecting rod bearings, apply engine oil to the bearing surface (crankshaft side). Do not apply oil to the back surface (connecting rod and cap side), but thoroughly clean it.
- When installing, align the connecting rod bearing protrusion with the notch of the connecting rod to install.
- Check that the oil holes on the connecting rod and on the corresponding bearing are aligned.

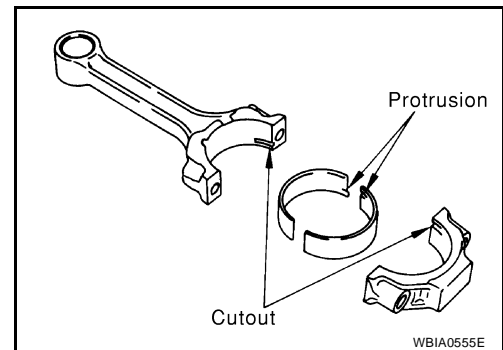

13. Install the piston and connecting rod assembly into the corresponding cylinder.

- Position the crankshaft pin corresponding to the connecting rod to be installed onto the bottom dead center.
- Apply engine oil sufficiently to the cylinder bore, piston, and crankshaft pin.
- Match the cylinder position with the cylinder No. on the connecting rod to install.
- Install the piston using Tool with the front mark on the piston crown facing the front of the engine.

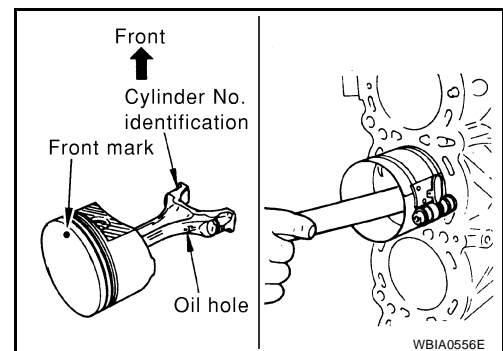

Tool number : EM03470000 (J-8037)

CAUTION:

Be careful not to damage the crankshaft pin and cylinder wall, resulting from an interference of the connecting rod big end.

CYLINDER BLOCK

14. Install the connecting rod cap.

- Match the stamped cylinder number marks on the connecting rod with those on the cylinder cap for installation.
- Install the piston connecting rod assembly and cap so that the front mark on the cap and piston are facing the front of the engine.
- Lubricate the threads and seat surfaces with new engine oil.

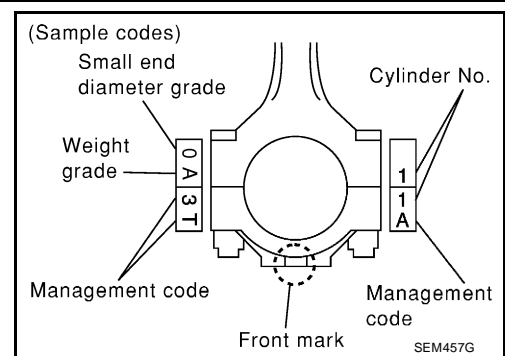

15. Check the connecting rod cap bolts before reusing, then install in their original position in the connecting rod. The bolts should screw in smoothly by hand.

- Measure the outer diameter of the connecting rod cap bolt as shown.

Outer diameter "d" of the connecting rod bolt
Standard : 7.90 - 8.00 mm (0.3110 - 0.3150 in)
Limit : 7.75 mm (0.3051 in)

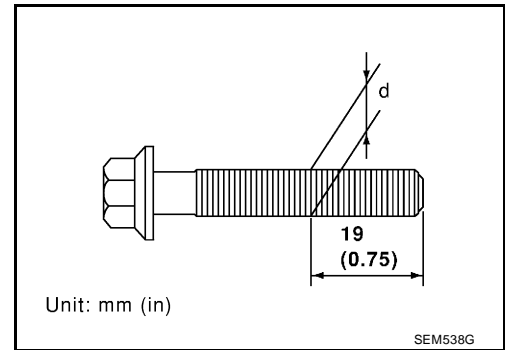

16. Tighten the connecting rod bolts in two steps:

Connecting rod bolts
Step 1 : 20 N·m (2.0 kg-m, 15 ft-lb)
Step 2 : 90° - 95° degrees clockwise

CAUTION:
Always use either an angle wrench or protractor. Avoid tightening based on visual check alone.

Tool number : KV10112100 (BT-8653-A)

- Apply engine oil to the threads and seats of the connecting rod bolts.
- After tightening the bolts, make sure that the crankshaft rotates smoothly.
- Check the connecting rod side clearance. If beyond the limit, replace the connecting rod and/or crankshaft.

Connecting rod side clearance:
Standard : 0.20 - 0.35 mm (0.0079 - 0.0138 in)
Limit : 0.40 mm (0.0157 in)

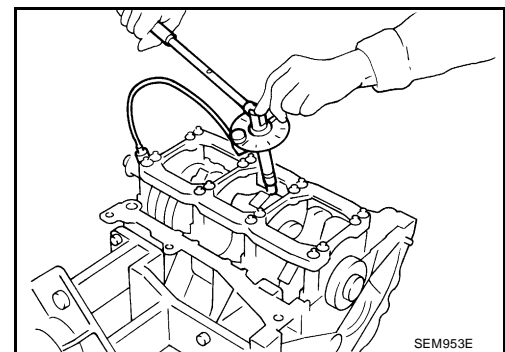

17. Install the baffle plate.

18. Install the knock sensor.

- Make sure that there is no foreign material on the cylinder block mating surface and the back surface of the knock sensor.
- Install the knock sensor with the connector facing the rear of the engine.
- Do not tighten the knock sensor bolt while holding the connector.
- Make sure that the knock sensor does not interfere with other parts.

CAUTION:
If any impact by dropping occurs to the knock sensor, replace it with new one.

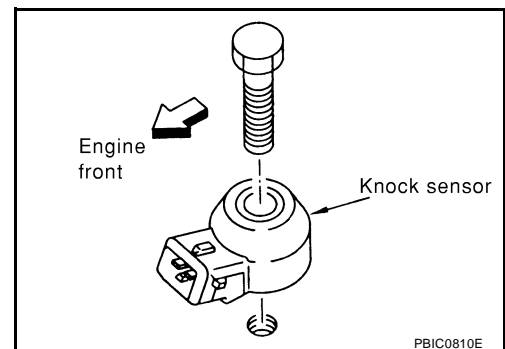

CYLINDER BLOCK

19. Install the pilot converter using suitable tool.

Outer diameter of drift

Pilot converter : Approx. 33 mm (1.30 in)

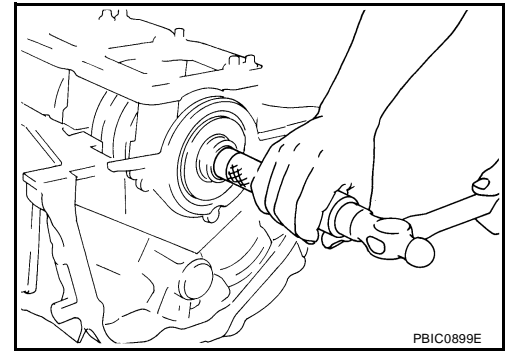

- Install pilot converter as shown.

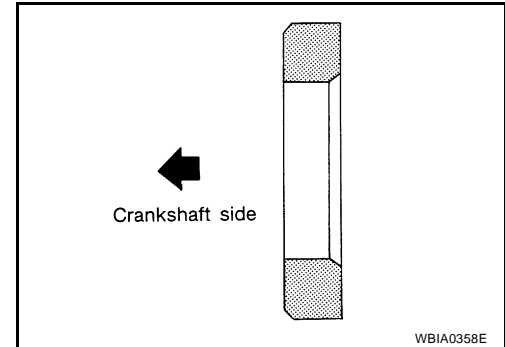

20. Install the drive plate and reinforcement plate in the direction shown.

CAUTION:

- Ensure the dowel pin is installed in the crankshaft.
- When installing the drive plate to crankshaft, be sure to correctly align crankshaft side dowel pin and drive plate side dowel pin hole.
- Tighten drive plate bolts crosswise several times.

NOTE:

- Secure the drive plate using Tool.

Tool number : KV10117700 (J-44716)

- Unlock drive plate, remove Tool.

Tool number : KV10117700 (J-44716)

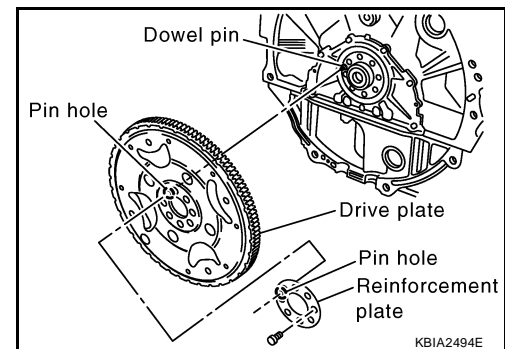

21. Install the cylinder head. Refer to [EM-97, "Removal and Installation"](#) .

22. Install the oil pump. Refer to [LU-12, "INSTALLATION"](#) .

23. Install the timing chain. Refer to [EM-56, "Removal and Installation"](#) .

24. Install the upper and lower oil pans. Refer to [EM-33, "INSTALLATION"](#) .

25. Remove the engine from the stand and install the engine assembly into the vehicle. Refer to [EM-112, "Removal and Installation"](#) .

26. Assembly of the remaining parts is in the reverse order of disassembly.

27. Fill the engine with the specified oil and coolant. Refer to [MA-9, "Fluids and Lubricants"](#) .

CAUTION:

Wait at least 30 minutes for the sealant to set-up before filling the engine with fluids and running it.

CYLINDER BLOCK

EBS00PS6

How to Select Piston and Bearing DESCRIPTION

Selection points	Selection parts	Selection items	Selection methods
Between cylinder block and crankshaft	Main bearing	Main bearing grade (bearing thickness)	Determined by matching of cylinder block bearing housing grade (inner diameter of housing) and crankshaft journal grade (outer diameter of journal)
Between crankshaft and connecting rod	Connecting rod bearing	Connecting rod bearing grade (bearing thickness)	Combining service grades for connecting rod big end inner diameter and crankshaft pin outer diameter determine connecting rod bearing selection.
Between cylinder block and piston	Piston and piston pin assembly (The piston is available together with piston pin as an assembly.)	Piston grade (piston outer diameter)	Piston grade = cylinder bore grade (inner diameter of bore)
*Between piston and connecting rod	-	-	-

* For the service parts, the grade for fitting cannot be selected between a piston pin and a connecting rod. (Only 0 grade is available.) The information at the shipment from the plant is described as a reference.

- The identification grade stamped on each part is the grade for the dimension measured in new condition. This grade cannot apply to reused parts.
- For reused or repair parts, measure the dimension accurately. Determine the grade by comparing the measurement with the values or each selection table.
- For details of the measurement method of each part, the reuse standards and the selection method of the selective fitting parts, refer to the text.

HOW TO SELECT A PISTON

When New Cylinder Block is Used

- Check the cylinder bore grade (1, 2 or 3) on rear side of cylinder block, and select a piston of the same grade.
- The piston is available with piston pin as a set for the service part. (Only 0 grade piston pin is available.)

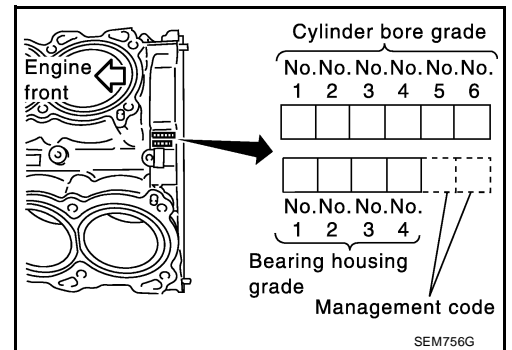

When Cylinder Block is Reused

1. Measure the cylinder block bore inner diameter.
2. Determine the bore grade by comparing the measurement with the values under the cylinder bore inner diameter of the [EM-130, "Piston Selection Table"](#).
3. Select the piston of the same grade.

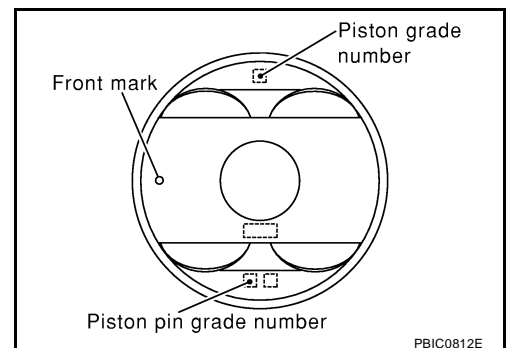

CYLINDER BLOCK

Piston Selection Table

Unit: mm (in)

Grade	1	2 (or no mark)	3
Inner diameter of cylinder bore	95.500 - 95.510 (3.7598 - 3.7602)	95.510 - 95.520 (3.7602 - 3.7606)	95.520 - 95.530 (3.7606 - 3.7610)
Outer diameter of piston	95.480 - 95.490 (3.7590 - 3.7594)	95.490 - 95.500 (3.7594 - 3.7598)	95.500 - 95.510 (3.7598 - 3.7602)

NOTE:

- The piston is available together with piston pin as an assembly.
- The piston pin (piston pin bore) grade is provided only for the parts installed at the plant. For service parts, no piston pin grades can be selected. (Only 0 grade is available.)
- No grade mark is indicated on 2 grade piston.

HOW TO SELECT CONNECTING ROD BEARINGS

When New Connecting Rod and Crankshaft are Used

Check pin diameter grade number (0, 1 or 2) stamped in front of crankshaft and select connecting rod bearing of same grade number.

NOTE:

There is no grading for connecting rod big end inner diameter.

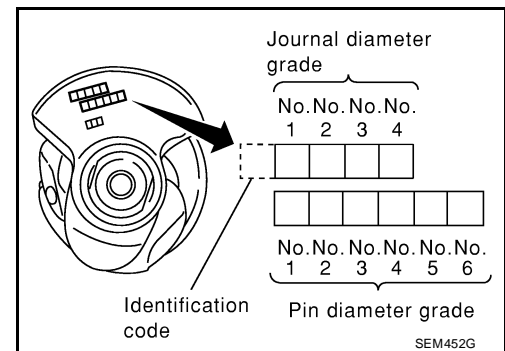

When Crankshaft and Connecting Rod are Reused

1. Measure dimensions of the big end inner diameter of connecting rod and outer diameter of crankshaft pin individually.
2. Confirm the big end inner diameter of connecting rod is within the standard value.
3. Apply the measured dimension to the [EM-130, "Connecting Rod Bearing Selection Table"](#).
4. Determine the grade of crankshaft pin diameter grade by comparing the measurement with the values under the crankshaft pin outer diameter of the [EM-130, "Connecting Rod Bearing Selection Table"](#).

Connecting Rod Bearing Selection Table

Unit: mm (in)

Connecting rod big end inner diameter		55.000 - 55.013 (2.1654 - 2.1659)
Crankshaft pin outer diameter	Grade (Mark)	– (No grade)
51.968 - 51.974 (2.0460 - 2.0462)	0	Bearing grade No. STD 0 Bearing thickness range: 1.500 - 1.503 (0.00591 - 0.0592) Color: Black
51.962 - 51.968 (2.0457 - 2.0460)	1	Bearing grade No. STD 1 Bearing thickness range: 1.503 - 1.506 (0.00592 - 0.0593) Color: Brown
51.956 - 51.962 (2.0455 - 2.0457)	2	Bearing grade No. STD 2 Bearing thickness range: 1.506 - 1.509 (0.00593 - 0.0594) Color: Green

Undersize Bearings Usage Guide

- When the specified oil clearance is not obtained with standard size connecting rod bearings use undersize bearings.
- When using undersize bearings measure the bearing inner diameter with bearing installed and grind the crankshaft pin so that the oil clearance satisfies the standard.

CYLINDER BLOCK

Bearing Undersize Table

Unit: mm (in)

Size	Thickness
0.25 (0.0098)	1.626 - 1.634 (0.0640 - 0.0643)

CAUTION:

In grinding the crankshaft pin to use undersize bearings, keep the fillet R (all crankshaft pins).

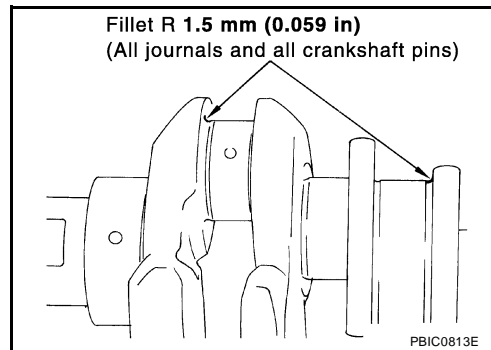

HOW TO SELECT MAIN BEARINGS

When New Cylinder Block and Crankshaft are Used

1. [EM-132, "Main Bearing Selection Table"](#) rows correspond to bearing housing grade on rear left side of cylinder block.

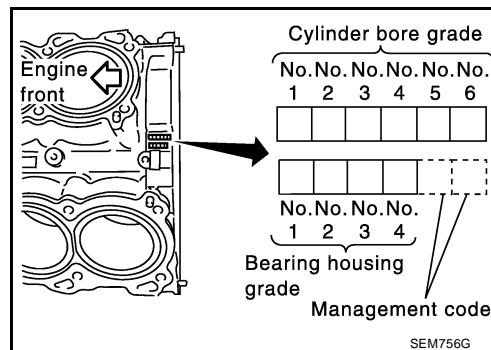

2. Apply journal diameter grade stamped on crankshaft front side to column in [EM-132, "Main Bearing Selection Table"](#).
3. Find sign (main bearing grade) at crossing of row and column in [EM-132, "Main Bearing Selection Table"](#).

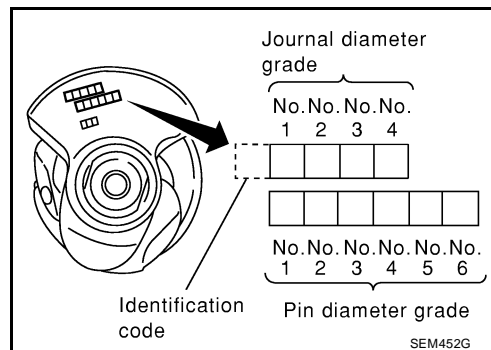

When Cylinder Block and Crankshaft are Reused

1. Measure inner diameter of cylinder block main bearing housing and outer diameter of crankshaft journal.
2. Find measured dimension in "Cylinder block bearing housing inner diameter" row of [EM-132, "Main Bearing Selection Table"](#).
3. Find the measured dimension in "Crankshaft main journal diameter" column in [EM-132, "Main Bearing Selection Table"](#).
4. Select main bearing grade at the point where selected row and column intersect.

CYLINDER BLOCK

Main Bearing Selection Table

<div style="display: flex; justify-content: space-around;"> <div style="width: 45%; text-align: center;"> Cylinder block bearing housing inner diameter Unit: mm (in) </div> <div style="width: 45%; text-align: center;"> Crankshaft main journal diameter Unit: mm (in) </div> </div>		Mark																								
		Hole diameter																								
Mark	Axle diameter	A	B	C	D	E	F	G	H	J	K	L	M	N	P	R	S	T	U	V	W	X	Y	4	7	
A	59.975 - 59.974 (2.3612 - 2.3612)	0	0	0	01	01	01	1	1	1	1	1	1	1	2	2	2	2	2	3	3	3	3	3	3	3
B	59.974 - 59.973 (2.3612 - 2.3611)	0	0	01	01	01	01	1	1	1	1	1	1	1	2	2	2	2	2	3	3	3	3	3	3	3
C	59.973 - 59.972 (2.3611 - 2.3611)	0	01	01	01	01	1	1	1	1	1	1	1	1	2	2	2	2	2	3	3	3	3	3	3	3
D	59.972 - 59.971 (2.3611 - 2.3611)	01	01	01	1	1	1	1	1	1	1	1	1	1	2	2	2	2	2	3	3	3	3	3	3	3
E	59.971 - 59.970 (2.3611 - 2.3610)	01	01	1	1	1	1	1	1	1	1	1	1	1	2	2	2	2	2	3	3	3	3	3	3	3
F	59.970 - 59.969 (2.3610 - 2.3610)	01	1	1	1	1	1	1	1	1	1	1	1	1	2	2	2	2	2	3	3	3	3	3	3	3
G	59.969 - 59.968 (2.3610 - 2.3609)	1	1	1	1	1	1	1	1	1	1	1	1	1	2	2	2	2	2	3	3	3	3	3	3	3
H	59.968 - 59.967 (2.3609 - 2.3609)	1	1	1	1	1	1	1	1	1	1	1	1	1	2	2	2	2	2	3	3	3	3	3	3	3
J	59.967 - 59.966 (2.3609 - 2.3609)	1	1	1	1	1	1	1	1	1	1	1	1	1	2	2	2	2	2	3	3	3	3	3	3	3
K	59.966 - 59.965 (2.3909 - 2.3608)	1	1	1	1	1	1	1	1	1	1	1	1	1	2	2	2	2	2	3	3	3	3	3	3	3
L	59.965 - 59.964 (2.3608 - 2.3608)	1	1	1	1	1	1	1	1	1	1	1	1	1	2	2	2	2	2	3	3	3	3	3	3	3
M	59.964 - 59.963 (2.3608 - 2.3607)	1	1	1	1	1	1	1	1	1	1	1	1	1	2	2	2	2	2	3	3	3	3	3	3	3
N	59.963 - 59.962 (2.3607 - 2.3607)	1	1	1	1	1	1	1	1	1	1	1	1	1	2	2	2	2	2	3	3	3	3	3	3	3
P	59.962 - 59.961 (2.3607 - 2.3607)	1	1	1	1	1	1	1	1	1	1	1	1	1	2	2	2	2	2	3	3	3	3	3	3	3
R	59.961 - 59.960 (2.3607 - 2.3606)	1	1	1	1	1	1	1	1	1	1	1	1	1	2	2	2	2	2	3	3	3	3	3	3	3
S	59.960 - 59.959 (2.3606 - 2.3606)	1	1	1	1	1	1	1	1	1	1	1	1	1	2	2	2	2	2	3	3	3	3	3	3	3
T	59.959 - 59.958 (2.3606 - 2.3605)	1	1	1	1	1	1	1	1	1	1	1	1	1	2	2	2	2	2	3	3	3	3	3	3	3
U	59.958 - 59.957 (2.3605 - 2.3605)	1	1	1	1	1	1	1	1	1	1	1	1	1	2	2	2	2	2	3	3	3	3	3	3	3
V	59.957 - 59.956 (2.3605 - 2.3605)	1	1	1	1	1	1	1	1	1	1	1	1	1	2	2	2	2	2	3	3	3	3	3	3	3
W	59.956 - 59.955 (2.3605 - 2.3604)	1	1	1	1	1	1	1	1	1	1	1	1	1	2	2	2	2	2	3	3	3	3	3	3	3
X	59.955 - 59.954 (2.3604 - 2.3604)	1	1	1	1	1	1	1	1	1	1	1	1	1	2	2	2	2	2	3	3	3	3	3	3	3
Y	59.954 - 59.953 (2.3604 - 2.3603)	1	1	1	1	1	1	1	1	1	1	1	1	1	2	2	2	2	2	3	3	3	3	3	3	3
4	59.953 - 59.952 (2.3603 - 2.3603)	1	1	1	1	1	1	1	1	1	1	1	1	1	2	2	2	2	2	3	3	3	3	3	3	3
7	59.952 - 59.951 (2.3603 - 2.3603)	1	1	1	1	1	1	1	1	1	1	1	1	1	2	2	2	2	2	3	3	3	3	3	3	3

PBIC0814E

CYLINDER BLOCK

Main Bearing Grade Table (All Journals)

Grade number	Thickness "T" mm (in)	Width "W" mm (in)	Identification color (UPR/LWR)	Remarks	
0	2.000 - 2.003 (0.0787 - 0.0789)	19.9 - 20.1 (0.783 - 0.791)	Black	Grade is the same for upper and lower bearings.	
1	2.003 - 2.006 (0.0789 - 0.0790)		Brown		
2	2.006 - 2.009 (0.0790 - 0.0791)		Green		
3	2.009 - 2.012 (0.0791 - 0.0792)		Yellow		
4	2.012 - 2.015 (0.0792 - 0.0793)		Blue		
5	2.015 - 2.018 (0.0793 - 0.0794)		Pink		
6	2.018 - 2.021 (0.0794 - 0.0796)		Purple		
7	2.021 - 2.024 (0.0796 - 0.0797)		White	Grade is different for upper and lower bearings.	
01	UPR		2.003 - 2.006 (0.0789 - 0.0790)		Brown/Black
	LWR		2.000 - 2.003 (0.0787 - 0.0789)		
12	UPR		2.006 - 2.009 (0.0790 - 0.0791)		Green/Brown
	LWR		2.003 - 2.006 (0.0789 - 0.0790)		
23	UPR		2.009 - 2.012 (0.0791 - 0.0792)		Yellow/Green
	LWR		2.006 - 2.009 (0.0790 - 0.0791)		
34	UPR	2.012 - 2.015 (0.0792 - 0.0793)	Blue/Yellow		
	LWR	2.009 - 2.012 (0.0791 - 0.0792)			
45	UPR	2.015 - 2.018 (0.0793 - 0.0794)	Pink/Blue		
	LWR	2.012 - 2.015 (0.0792 - 0.0793)			
56	UPR	2.018 - 2.021 (0.0794 - 0.0796)	Purple/Pink		
	LWR	2.015 - 2.018 (0.0793 - 0.0794)			
67	UPR	2.021 - 2.024 (0.0796 - 0.0797)	White/Purple		
	LWR	2.018 - 2.021 (0.0794 - 0.0796)			

Undersize Bearing Usage Guide

- Use undersize bearing when oil clearance with standard size main bearing is not within specification.

CAUTION:

Keep fillet R when grinding crankshaft journal in order to use undersize bearing (all journals).

- When using undersize bearing, measure the bearing inner diameter with bearing installed, and grind journal until oil clearance falls within specification.

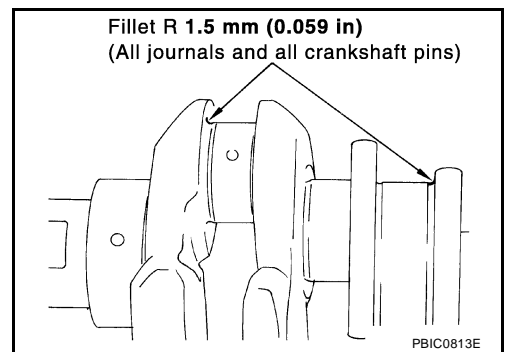

Bearing Undersize Table

Unit: mm (in)

Size	Thickness
0.25 (0.0098)	2.132 - 2.140 (0.0839 - 0.0843)

CYLINDER BLOCK

EBS00PS7

Inspection After Disassembly CRANKSHAFT END PLAY

- Using a dial indicator, measure the clearance between the thrust bearings and the crankshaft arms when the crankshaft is moved from front to rear.

Standard : 0.10 - 0.25 mm (0.0039 - 0.0098 in)

Limit : 0.30 mm (0.0118 in)

- If beyond the limit, replace the thrust bearings and measure again. If still beyond the limit, replace the crankshaft.

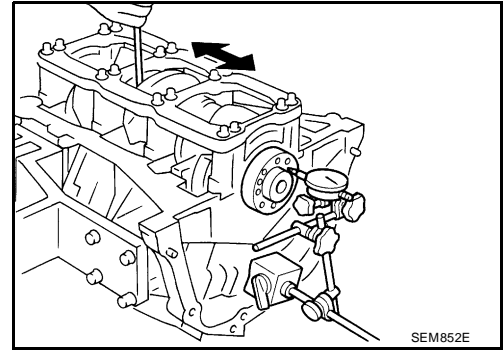

CONNECTING ROD SIDE CLEARANCE

- Measure the side clearance between the connecting rod and crankshaft with a feeler gauge.

Standard : 0.20 - 0.35 mm (0.0079 - 0.0138 in)

Limit : 0.40 mm (0.0157 in)

- If beyond the limit, replace the connecting rod and measure again. If still beyond the limit, replace the crankshaft.

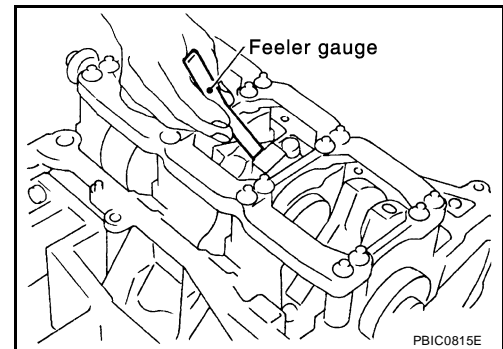

PISTON AND PISTON PIN CLEARANCE

Inner Diameter of Piston Pin Hole

- Measure the inner diameter of piston pin hole "dp".

Standard diameter "dp"

Grade No. 0 : 21.993 - 21.999 mm (0.8659 - 0.8661 in)

Grade No. 1 : 21.999 - 22.005 mm (0.8661 - 0.8663 in)

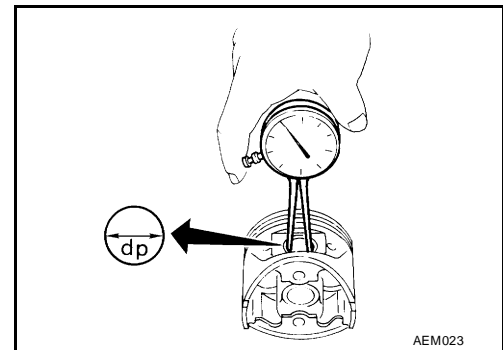

Outer Diameter of Piston Pin

- Measure outer diameter of piston pin "Dp".

Standard diameter "Dp"

Grade No. 0 : 21.989 - 21.995 mm (0.8657 - 0.8659 in)

Grade No. 1 : 21.995 - 22.001 mm (0.8659 - 0.8662 in)

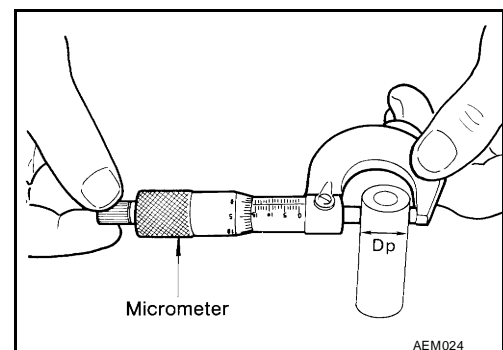

CYLINDER BLOCK

Piston and Piston Pin Interference Fit

Standard Interference Fit = "Dp" – "dp"

Standard : 0.002 mm - 0.006 mm (0.0001 - 0.0002 in)

- If clearance exceeds specification, replace piston/piston pin assembly and connecting rod assembly with reference to specification of each part.
- When replacing piston/piston pin assembly, refer to [EM-138, "PISTON-TO-CYLINDER BORE CLEARANCE"](#).

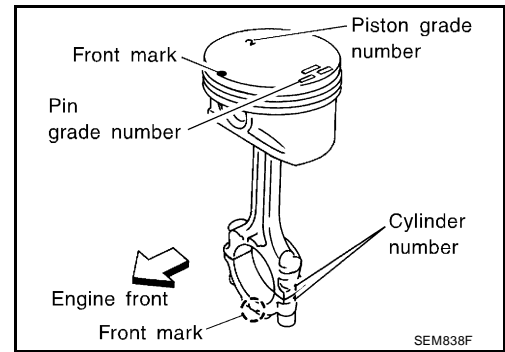

PISTON RING SIDE CLEARANCE

- Measure side clearance of piston ring and piston ring groove with feeler gauge.

Standard Side Clearance

Top ring : 0.045 - 0.080 mm (0.0018 - 0.0031 in)

2nd ring : 0.030 - 0.070 mm (0.0012 - 0.0028 in)

Oil ring : 0.065 - 0.135 mm (0.0026 - 0.0053 in)

Maximum Limit

Top ring : 0.11 mm (0.0043 in)

2nd ring : 0.1 mm (0.004 in)

Oil ring : —

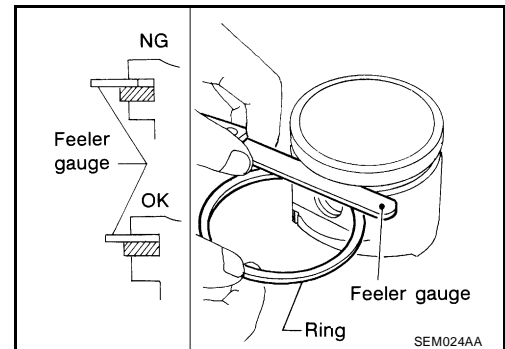

- If out of specification, replace piston ring assembly. If clearance exceeds maximum limit with new rings, replace piston

PISTON RING END GAP

- Check if inner diameter of cylinder bore is within specification. Refer to [EM-138, "PISTON-TO-CYLINDER BORE CLEARANCE"](#).
- Insert piston ring until it is in the middle of the cylinder bore and measure the end gap.

Standard

Top ring : 0.23 - 0.33 mm (0.0091 - 0.0130 in)

2nd ring : 0.33 - 0.48 mm (0.0130 - 0.0189 in)

Oil ring : 0.20 - 0.50 mm (0.0079 - 0.0197 in)

Limit:

Top ring : 0.54 mm (0.0213 in)

2nd ring : 0.80 mm (0.0315 in)

Oil ring : 0.95 mm (0.0374 in)

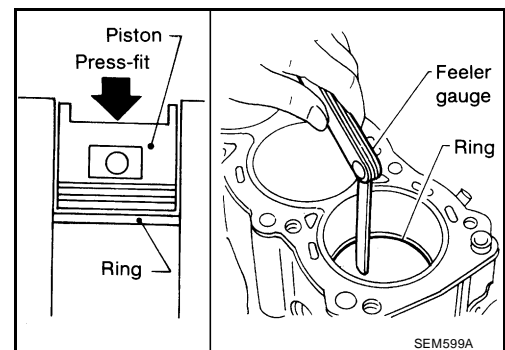

- If out of specification, replace piston ring. If gap still exceeds the limit even with a new ring, re-bore cylinder and use oversized piston and piston ring.

CYLINDER BLOCK

CONNECTING ROD BEND AND TORSION

Bend : Limit 0.15 mm (0.0059 in) per 100 mm (3.94 in) length

Torsion : Limit 0.30 mm (0.0118 in) per 100 mm (3.94 in) length

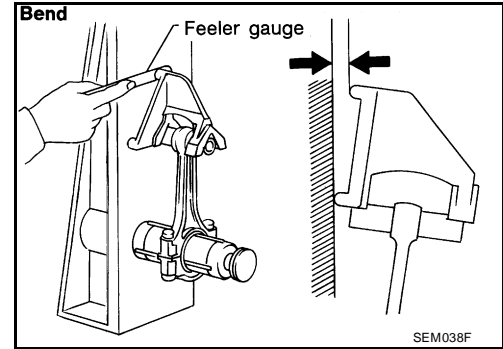

- If it exceeds the limit, replace connecting rod assembly.

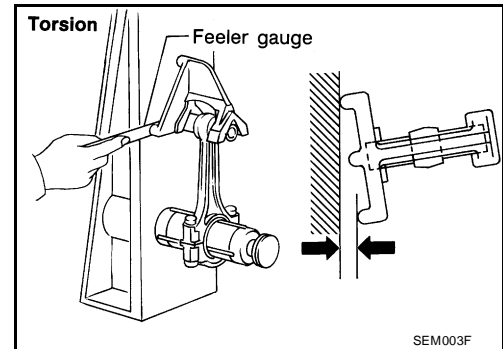

CONNECTING ROD BEARING HOUSING DIAMETER (BIG END)

- Install the connecting rod cap without the connecting rod bearing installed. After tightening the connecting rod bolt to the specified torque, measure the connecting rod bearing housing big end inner diameter using an inside micrometer.

Standard : 55.000 - 55.013 mm (2.1654 - 2.1659 in)

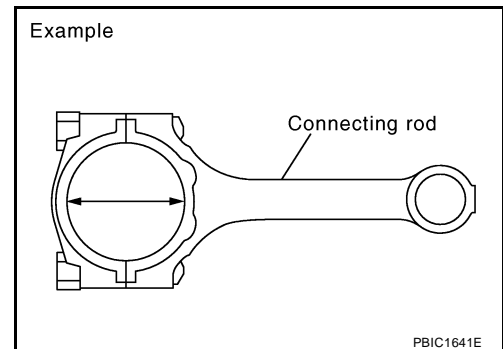

CONNECTING ROD BUSHING OIL CLEARANCE (SMALL END)

Inner Diameter of Connecting Rod (Small End)

- Measure inner diameter of piston pin bushing.

Standard

Grade No. 0 : 22.000 - 22.006 mm (0.8661 - 0.8664 in)

Grade No. 1 : 22.006 - 22.012 mm (0.8664 - 0.8666 in)

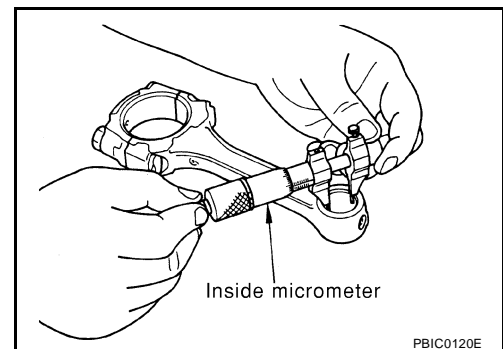

CYLINDER BLOCK

Outer Diameter of Piston Pin

- Measure outer diameter of piston pin.

Standard

Grade No. 0 : 21.989 - 21.995 mm (0.8657 - 0.8659 in)

Grade No. 1 : 21.995 - 22.001 mm (0.8659 - 0.8662 in)

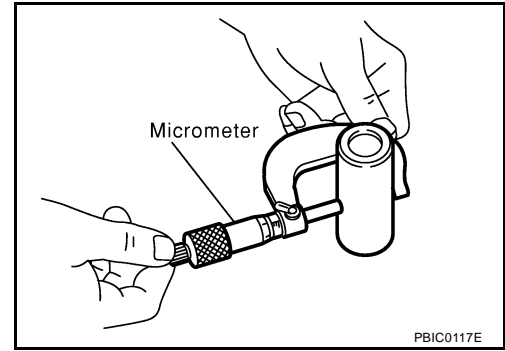

Connecting Rod Bushing Oil Clearance (Small End)

(Connecting rod small end oil clearance) = (Inner diameter of connecting rod small end) – (Outer diameter of piston pin)

Standard : 0.005 - 0.017 mm (0.0002 - 0.0007 in)

Limit : 0.030 mm (0.0012 in)

- If the measured value exceeds the standard, replace the connecting rod assembly and/or piston and piston pin assembly.
- If replacing the piston and piston pin assembly, refer to the Table for Selective Fitting for Piston to select the piston corresponding to the applicable bore grade of the cylinder block to be used. Refer to [EM-138, "PISTON-TO-CYLINDER BORE CLEARANCE"](#).
- If replacing the connecting rod assembly, refer to [EM-136, "CONNECTING ROD BUSHING OIL CLEARANCE \(SMALL END\)"](#).

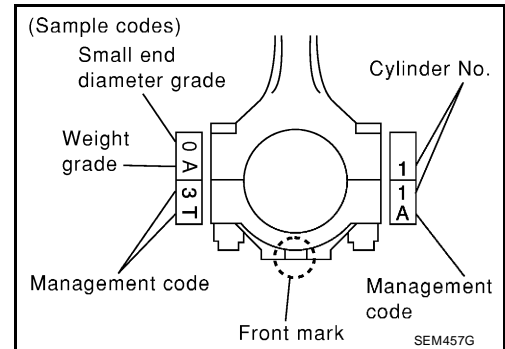

Factory installed parts grading:

- Service parts apply only to grade 0.

Grade	Unit: mm (in)	
	0	1
Piston pin bushing inner diameter*	22.000 - 22.006 (0.8661 - 0.8664)	22.006 - 22.012 (0.8664 - 0.8666)
Piston pin outer diameter	21.989 - 21.995 (0.8657 - 0.8659)	21.995 - 22.001 (0.8659 - 0.8662)
Piston pin hole diameter	21.993 - 21.999 (0.8659 - 0.8661)	21.999 - 22.005 (0.8661 - 0.8663)

*: After installing in connecting rod

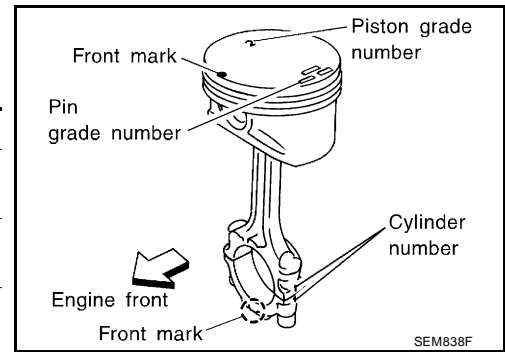

CYLINDER BLOCK DISTORTION

- Remove any old gasket material on the cylinder block surface, and remove any oil, scale, carbon, or other contamination using suitable tool.

CAUTION:

Be careful not to allow gasket flakes to enter the oil or coolant passages.

- Measure the distortion on the block upper face at different points in six directions.

Distortion limit : 0.10 mm (0.0039 in)

- If out of specification, resurface the cylinder block. The allowable amount of resurfacing is dependent on the amount of any cylinder head resurfacing. The resurfacing limit is [amount of cylinder head resurfacing] + [amount of cylinder head resurfacing] = 0.2 mm (0.008 in).

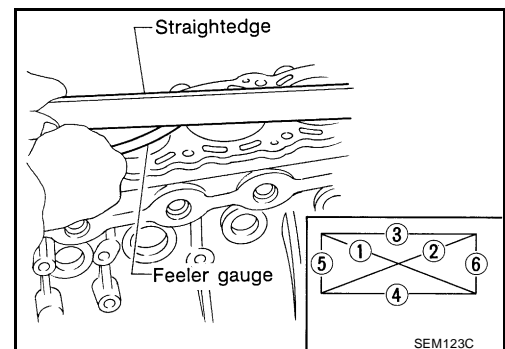

CYLINDER BLOCK

Cylinder block height : 214.95 - 215.05 mm (8.4626 - 8.4665 in)

INNER DIAMETER OF MAIN BEARING HOUSING

- Install the main bearing caps with the main bearings removed, and tighten the bolts to the specified torque.
- Using a bore gauge, measure the inner diameter of the main bearing housing.

Standard : 63.993 - 64.017 mm (2.5194 - 2.5203 in)

- If out of the standard, replace the cylinder block and main bearing caps as an assembly.

NOTE:

These components cannot be replaced individually, since they were processed together.

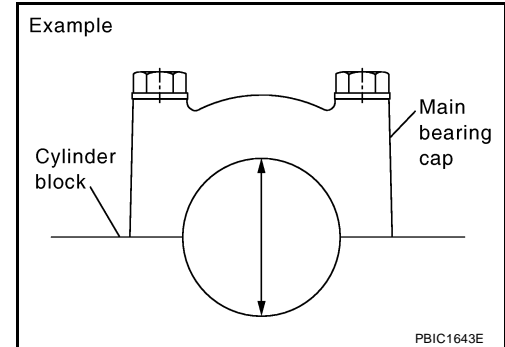

PISTON-TO-CYLINDER BORE CLEARANCE

1. Using a bore gauge, measure cylinder bore for wear, out-of-round and taper. The X axis is in the longitudinal direction of the engine.

Cylinder bore inner diameter

Grade No.	Standard inner diameter	Wear limit
No. 1	95.500 - 95.510 mm (3.7598 - 3.7602 in)	0.20 mm (0.0079 in)
No. 2	95.510 - 95.520 mm (3.7602 - 3.7606 in)	
No. 3	95.520 - 95.530 mm (3.7606 - 3.7610 in)	

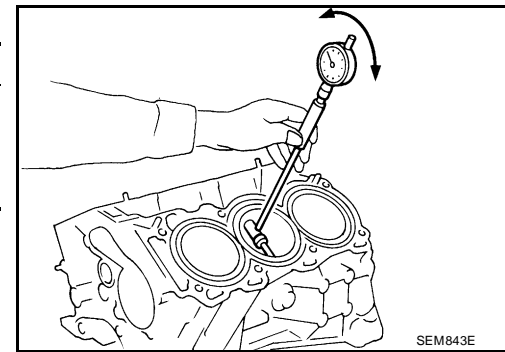

If it exceeds the limit, re bore all cylinders. Replace cylinder block if necessary.

Out-of-round (Difference between, X - Y) : less than 0.015 mm (0.0006 in)

Taper (Difference between, C - A) : less than 0.015 mm (0.0006 in)

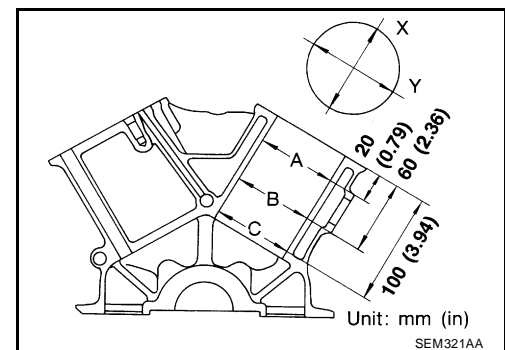

2. Check for scratches and seizure. If seizure is found, hone it.

- If both cylinder block and piston are replaced with new ones, select piston of the same grade number punched on cylinder block rear position. These numbers are punched in either Arabic or Roman numerals.

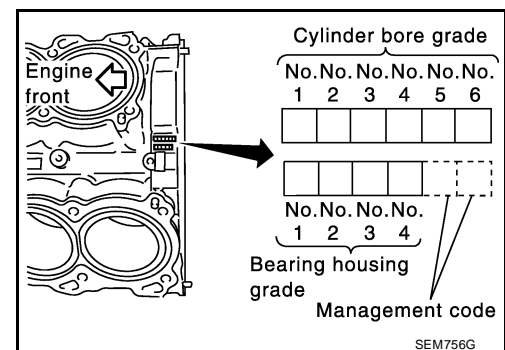

CYLINDER BLOCK

3. Measure piston skirt diameter.

Piston diameter "A" : Refer to [EM-151, "PISTON, PISTON RING AND PISTON PIN"](#) .

Measuring point "a" (distance from the top) : 41.0 mm (1.614 in)

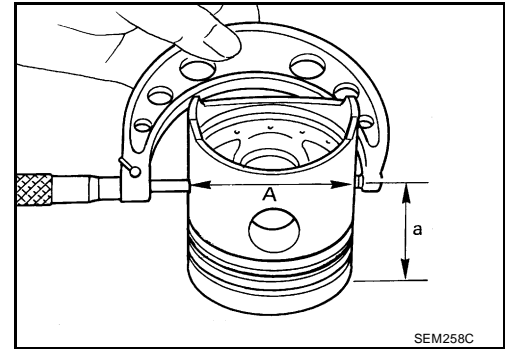

4. Check that piston-to-bore clearance is within specification.

Piston-to-bore clearance at "B" : 0.010 - 0.030 mm (0.0004 - 0.0012 in)

- The piston-to-bore clearance is measured at the "B" level in the cylinder as shown.

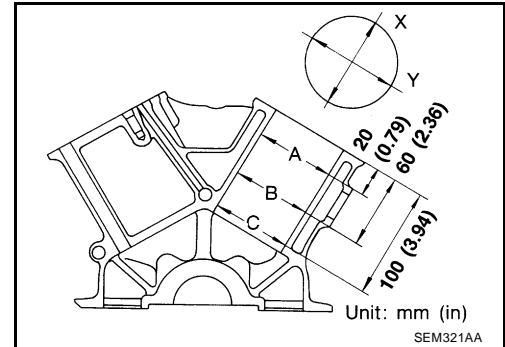

5. Determine piston oversize according to amount of cylinder wear.

- Oversize pistons are available for service.
- If oversize piston is used, use it for all cylinders with oversize piston ring. Refer to [EM-151, "PISTON, PISTON RING AND PISTON PIN"](#) .

6. Cylinder bore size is determined by adding piston-to-bore clearance to piston diameter "A".

Rebored size calculation : $D = A + B - C$

where,

D : Bored diameter
A : Piston diameter as measured
B : Piston-to-bore clearance
C : Honing allowance 0.02 mm (0.0008 in)

7. Install main bearing caps, and tighten to the specified torque. Otherwise, cylinder bores may be distorted after boring.

8. Cut cylinder bores.

- When any cylinder needs boring, all other cylinders must also be bored.
- Do not cut too much out of cylinder bore at a time. Cut only 0.05 mm (0.0020 in) or so in diameter at a time.

- 9.hone cylinders to obtain specified piston-to-bore clearance.

10. Measure finished cylinder bore for out-of-round and taper.

- Measurement should be done after cylinder bore cools down.

CYLINDER BLOCK

OUTER DIAMETER OF CRANKSHAFT JOURNAL

Measure outer diameter of crankshaft journals. Refer to [EM-140, "OUT-OF-ROUND AND TAPER OF CRANKSHAFT"](#).

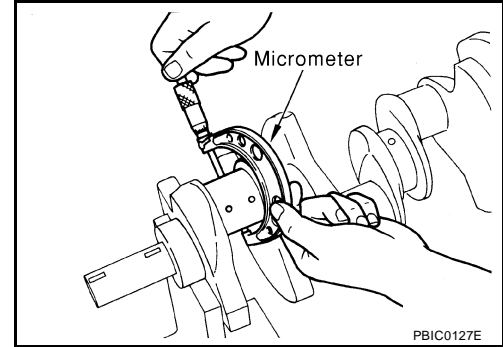

OUTER DIAMETER OF CRANKSHAFT PIN

Measure outer diameter of crankshaft pin. Refer to [EM-140, "OUT-OF-ROUND AND TAPER OF CRANKSHAFT"](#).

OUT-OF-ROUND AND TAPER OF CRANKSHAFT

- Check the crankshaft main and pin journals for scoring, wear, or cracks.
- Measure the journals for taper and out-of-round.

Standard

Out-of-round (difference between, X - Y) : 0.002 mm (0.0001 in)

Taper (difference between, A - B) : 0.002 mm (0.0001 in)

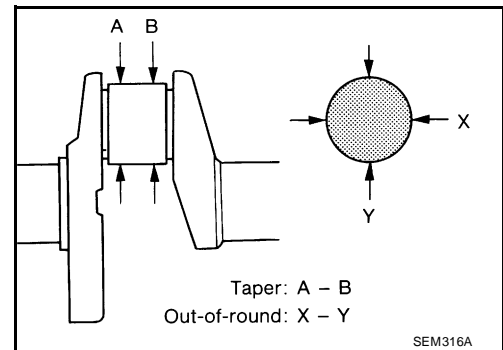

CRANKSHAFT RUNOUT

- Place a V-block on a precise flat table to support the journals on the both ends of the crankshaft.
- Place a dial gauge straight up on the No. 3 journal.
- While rotating the crankshaft, read the movement of the pointer on the dial gauge.

Runout limit (total indicator reading) : less than 0.10 mm (0.0039 in)

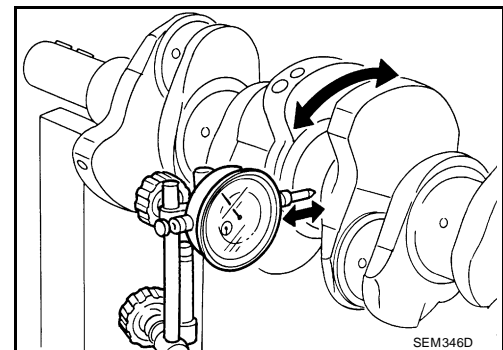

OIL CLEARANCE OF CONNECTING ROD BEARING

Method by Calculation

1. Install the connecting rod bearing to the connecting rod and cap.
2. Install the connecting rod cap to the connecting rod. Tighten to specification. Refer to [EM-122, "ASSEMBLY"](#).

CYLINDER BLOCK

3. Measure the inner diameter "C" of each connecting rod (big end) as shown.

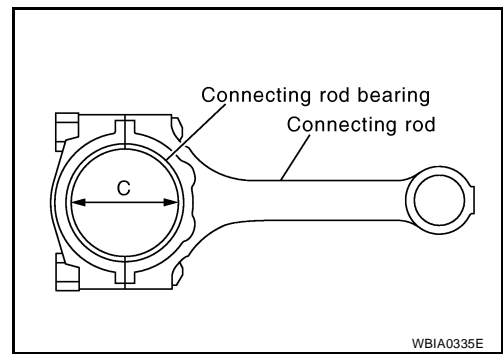

4. Measure the outer diameter "Dp" of each crankshaft pin journal.
5. Calculate the connecting rod bearing clearance.
Connecting rod bearing clearance = $C - D_p$

Standard : 0.034 - 0.059 mm (0.0013 - 0.0023 in)

Limit : 0.070 mm (0.0028 in)

6. If the clearance cannot be adjusted within the standard of any bearing, grind the crankshaft journal and use undersized bearings. Refer to [EM-130, "HOW TO SELECT CONNECTING ROD BEARINGS"](#).

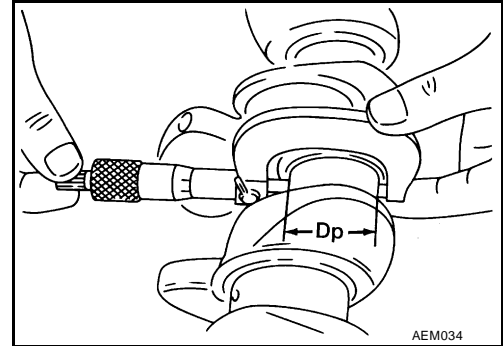

Method of Using Plastigage

- Remove oil and dust on the crankshaft pin and the surfaces of each bearing completely.
- Cut a Plastigage slightly shorter than the bearing width, and place it in crankshaft axial direction, avoiding oil holes.
- Install the connecting rod bearings to the connecting rod cap, and tighten the connecting rod bolts to the specified torque. Refer to [EM-118, "CYLINDER BLOCK"](#)

CAUTION:

Never rotate the crankshaft.

- Remove the connecting rod cap and bearings, and using the scale on the Plastigage bag, measure the Plastigage width.

NOTE:

The procedure when the measured value exceeds the repair limit is same as that described in [EM-140, "Method by Calculation"](#).

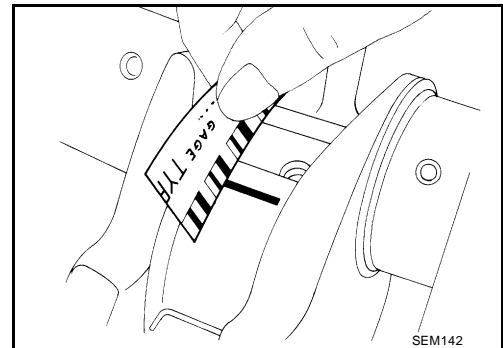

OIL CLEARANCE OF MAIN BEARING

Method by Calculation

1. Install the main bearings to the cylinder block and bearing cap. Refer to [EM-122, "ASSEMBLY"](#).
2. Calculate the main bearing clearance. (Oil clearance) = (Inner diameter of main bearing) - (Outer diameter of crankshaft journal)

Standard : 0.035 - 0.045 mm (0.0014 - 0.0018 in)

Limit : 0.065 mm (0.0026 in)

3. If the calculated clearance exceeds the specified limit, replace the bearings. Refer to [EM-131, "HOW TO SELECT MAIN BEARINGS"](#).

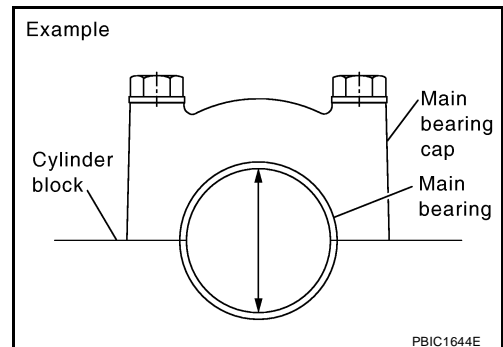

CYLINDER BLOCK

Method of Using Plastigage

- Remove oil and dust on the crankshaft pin and the surfaces of each bearing completely.
- Cut a Plastigage slightly shorter than the bearing width, and place it in crankshaft axial direction, avoiding oil holes.
- Install the main bearings and main bearing caps. Refer to [EM-122, "ASSEMBLY"](#).

CAUTION:

Never rotate the crankshaft.

- Remove the main bearing caps and bearings, and using the scale on the Plastigage bag, measure the Plastigage width.

NOTE:

The procedure when the measured value exceeds the repair limit is same as that described in [EM-141, "Method by Calculation"](#).

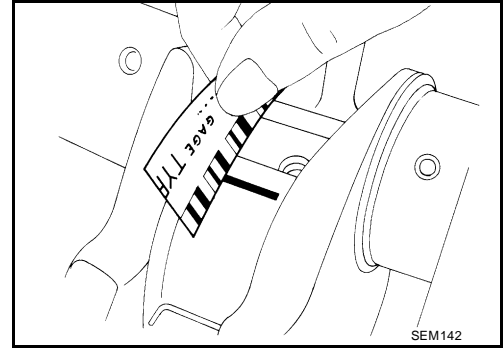

CRUSH HEIGHT OF MAIN BEARING

- When the bearing cap is removed after being tightened to the specified torque with main bearings installed, the tip end of the bearing must protrude. Refer to [EM-122, "ASSEMBLY"](#) for tightening procedure.

Standard : There must be a crush height.

- If the standard is not met, replace main bearings.

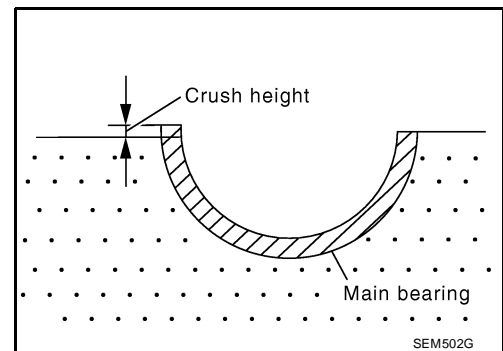

CRUSH HEIGHT OF CONNECTING ROD BEARING

- When the connecting rod bearing cap is removed after being tightened to the specified torque with connecting rod bearings installed, the tip end of the bearing must protrude. Refer to [EM-122, "ASSEMBLY"](#) for tightening procedure.

Standard : There must be a crush height.

- If the standard is not met, replace connecting rod bearings.

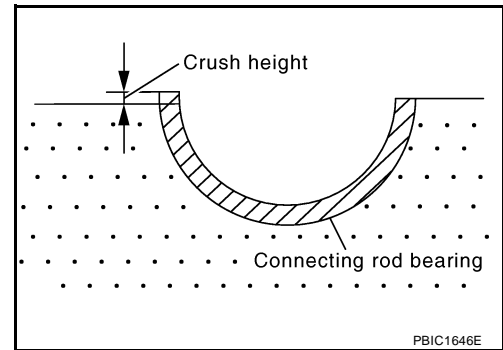

OUTER DIAMETER OF MAIN BEARING CAP BOLTS

Check specifications for the re-use of the main bearing cap bolts.

- Measure d1 and d2 as shown.
- For d2, select the minimum diameter in the measuring area.
- If the difference between d1 and d2 exceeds the limit, replace the bolts for assembly.

Limit (d1 - d2) : 0.11 mm (0.0043 in)

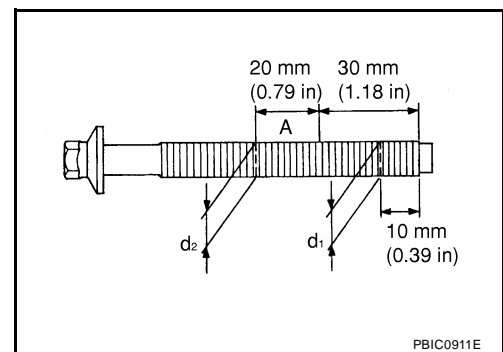

CYLINDER BLOCK

OUTER DIAMETER OF CONNECTING ROD BOLTS

- Measure outer diameter d as shown.
 - Standard : 7.90 - 8.00 mm (0.3110 - 0.3150 in)**
 - Limit : 7.75 mm (0.3051 in)**
- When the value of d exceeds the limit (when it becomes thinner) replace the bolt with a new one.

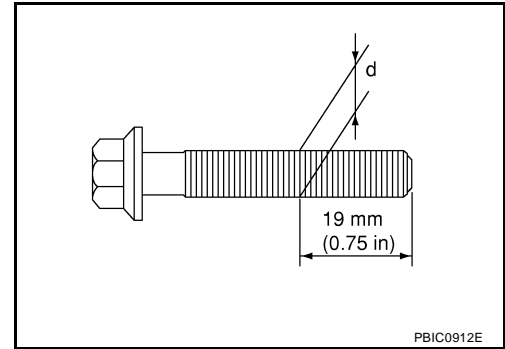

DRIVE PLATE

Check the drive plate and signal plate for deformation or damage.

CAUTION:

- The signal plate is built into the drive assembly. Be careful not to damage the signal plate, particularly the teeth.
- Check the drive plate and signal plate for deformation or cracks.
- Keep any magnetized objects away from the signal plate, particularly the teeth.

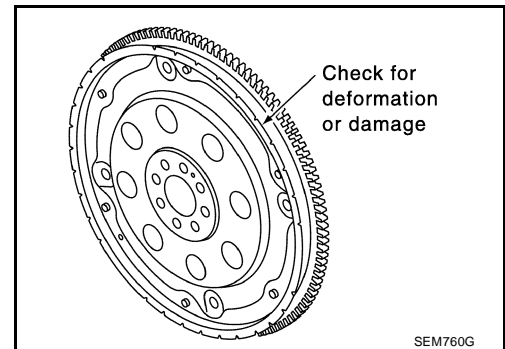

OIL JET

- Check nozzle for deformation and damage.
- Blow compressed air from nozzle, and check for clogs.
- If it is not satisfied, clean or replace oil jet.

OIL JET RELIEF VALVE

- Using a clean plastic stick, press check valve in oil jet relief valve. Make sure that valve moves smoothly with proper reaction force.
- If it is not satisfied, replace oil jet relief valve.

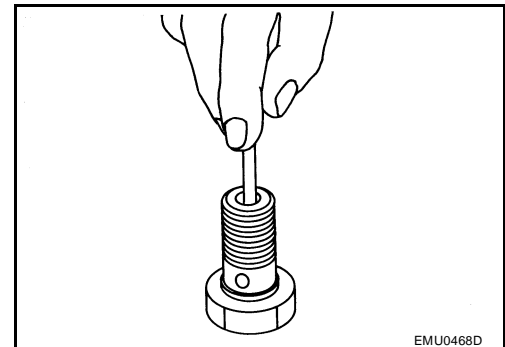

SERVICE DATA AND SPECIFICATIONS (SDS)

SERVICE DATA AND SPECIFICATIONS (SDS)

PF00100

Standard and Limit GENERAL SPECIFICATIONS

EBS00PS8

Cylinder arrangement		V-6
Displacement cm ³ (cu in)		3,498 (213.45)
Bore and stroke mm (in)		95.5 x 81.4 (3.760 x 3.205)
Valve arrangement		DOHC
Firing order		1-2-3-4-5-6
Number of piston rings	Compression	2
	Oil	1
Number of main bearings		4
Compression ratio		10.0:1
Compression pressure kPa (kg/cm ² , psi)/300 rpm	Standard	1,275 (13.0, 185)
	Minimum	981 (10.0, 142)
	Differential limit between cylinders	98 (1.0, 14)

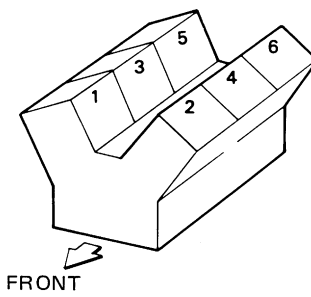
Cylinder number	 <p style="text-align: right; margin-top: 10px;">SEM713A</p>
-----------------	---

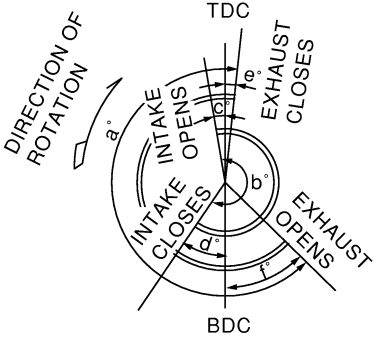
Valve timing (IVTC - OFF)	 <p style="text-align: right; margin-top: 10px;">PBIC0187E</p>
---------------------------	--

Unit: degree					
a	b	c	d	e	f
240°	238°	- 6°	64°	8°	52°

SERVICE DATA AND SPECIFICATIONS (SDS)

DRIVE BELT

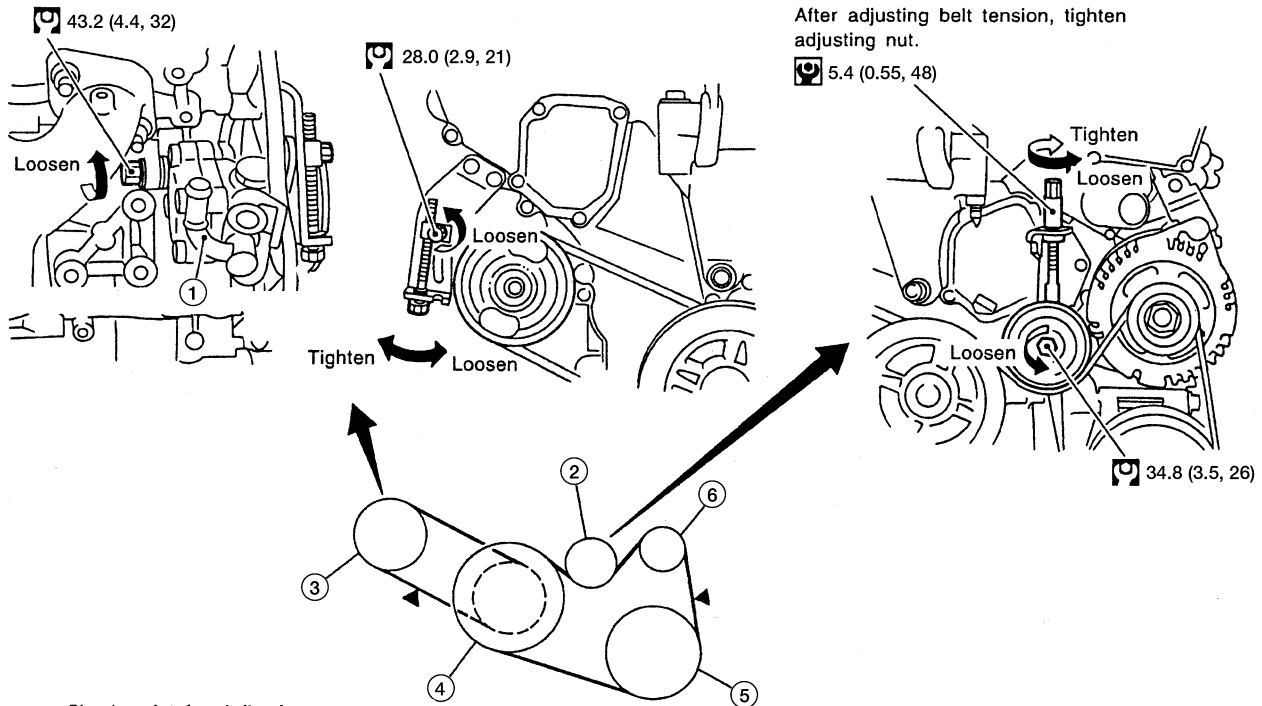

▼ : Check point for deflection

🔧 : N·m (kg-m, ft-lb)

🔧 : N·m (kg-m, in-lb)

- | | | |
|----------------------------|-------------------------------|----------------------------|
| 1. Power steering oil pump | 2. Idler pulley | 3. Power steering oil pump |
| 4. Crankshaft pulley | 5. Air conditioner compressor | 6. Generator |

WBIA0385E

	Deflection adjustment		Unit: mm (in)	Tension adjustment*		Unit: N (kg-f, lb-f)
	Used belt		New belt	Used belt		New belt
	Limit	After adjustment		Limit	After adjustment	
Generator and air conditioner compressor	7 (0.28)	4.2 - 4.6 (0.17 - 0.18)	3.7 - 4.1 (0.15 - 0.16)	294 (30, 66)	730 - 818 (74.5 - 83.5, 164 - 184)	838 - 926 (85.5 - 94.5, 188 - 208)
Power steering oil pump	11 (0.43)	7.3 - 8.0 (0.29 - 0.31)	6.5 - 7.2 (0.26 - 0.28)	196 (20, 44)	495 - 583 (50.5 - 59.5, 111 - 131)	603 - 691 (61.5 - 70.5, 135.6 - 155.4)
Applied pushing force	98 N (10 kg-f, 22 lb-f)			—		

*: If belt tension gauge cannot be installed at check points shown, check drive belt tension at different location on the belt.

INTAKE MANIFOLD COLLECTOR, INTAKE MANIFOLD AND EXHAUST MANIFOLD

Unit: mm (in)

Item	Limit	
Surface distortion	Intake manifold collector	0.1 (0.004)
	Intake manifold	0.1 (0.004)
	Exhaust manifold	0.3 (0.012)

SERVICE DATA AND SPECIFICATIONS (SDS)

SPARK PLUG

Make	NGK
Standard type	PLFR5A-11
Hot type	PLFR4A-11
Cold type	PLFR6A-11
Gap (nominal)	1.1 mm (0.043 in)

CYLINDER HEAD

Unit: mm (in)

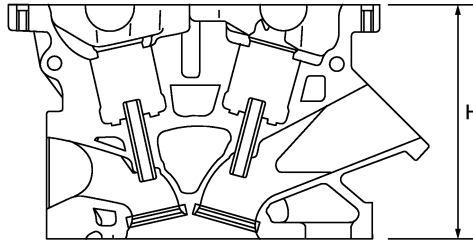

PBIC0924E

	Standard	Limit
Head surface distortion	—	0.1 (0.004)
Nominal cylinder head height "H"	126.3 - 126.5 (4.972 - 4.980)	—

VALVE

Valve Dimensions

Unit: mm (in)

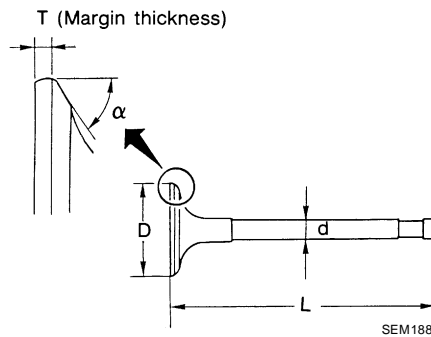

Valve head diameter "D"	Intake	37.0 - 37.3 (1.4567 - 1.4685)
	Exhaust	31.2 - 31.5 (1.228 - 1.240)
Valve length "L"	Intake	96.21 - 96.71 (3.7878 - 3.8075)
	Exhaust	93.74 - 94.24 (3.6905 - 3.7102)
Valve stem diameter "d"	Intake	5.965 - 5.980 (0.2348 - 0.2354)
	Exhaust	5.945 - 5.960 (0.2341 - 0.2346)
Valve seat angle " α " degree/minute (degree decimal)	Intake	45°25' - 46°75' (45.42° - 46.25°)
	Exhaust	
Valve margin "T"	Intake	1.15 - 1.45 (0.0453 - 0.0571)
	Exhaust	1.45 - 1.75 (0.0571 - 0.0689)
Valve margin "T" limit		More than 0.5 (0.020)
Valve stem end surface grinding limit		Less than 0.2 (0.008)
Valve oil seal installation height	14.3 14.9 mm (0.563 - 0.587 in)	

SERVICE DATA AND SPECIFICATIONS (SDS)

Valve Clearance

Unit: mm (in)

	Cold	Hot* (reference data)
Intake	0.26 - 0.34 (0.010 - 0.013)	0.304 - 0.416 (0.012 - 0.016)
Exhaust	0.29 - 0.37 (0.011 - 0.015)	0.308 - 0.432 (0.012 - 0.017)

*: Approximately 80°C (176°F)

Valve Spring

Free height mm (in)	46.90 (1.8465)
Pressure N (kg, lb) at height mm (in)	Standard 166 - 188 (16.9 - 19.2, 37.3 - 42.3) at 37.0 (1.457)
	Limit 378 - 426 (38.6 - 43.5, 85.0 - 95.8) at 27.8 (1.094)
Out-of-square mm (in)	Less than 2.0 (0.079)

Valve Lifter

Unit: mm (in)

Valve lifter outer diameter	33.977 - 33.987 (1.3377 - 1.3381)
Lifter lifter bore diameter	34.000 - 34.016 (1.3386 - 1.3392)
Clearance between lifter and lifter guide	0.013 - 0.039 (0.0005 - 0.0015)

Available Valve Lifter

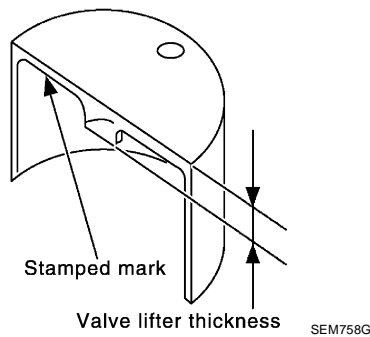

Identification Mark	Thickness mm (in)
788U	7.88 (0.3102)
790U	7.90 (0.3110)
792U	7.92 (0.3118)
794U	7.94 (0.3126)
796U	7.96 (0.3134)
798U	7.98 (0.3142)
800U	8.00 (0.3150)
802U	8.02 (0.3157)
804U	8.04 (0.3165)
806U	8.06 (0.3173)
808U	8.08 (0.3181)
810U	8.10 (0.3189)
812U	8.12 (0.3197)
814U	8.14 (0.3205)
816U	8.16 (0.3213)
818U	8.18 (0.3220)
820U	8.20 (0.3228)
822U	8.22 (0.3236)

SERVICE DATA AND SPECIFICATIONS (SDS)

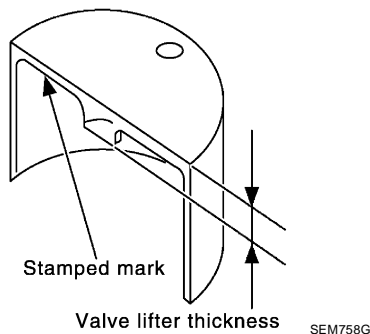

Identification Mark	Thickness mm (in)
824U	8.24 (0.3244)
826U	8.26 (0.3252)
828U	8.28 (0.3260)
830U	8.30 (0.3268)
832U	8.32 (0.3276)
834U	8.34 (0.3283)
836U	8.36 (0.3291)
838U	8.38 (0.3299)
840U	8.40 (0.3307)

Valve Guide

Unit: mm (in)

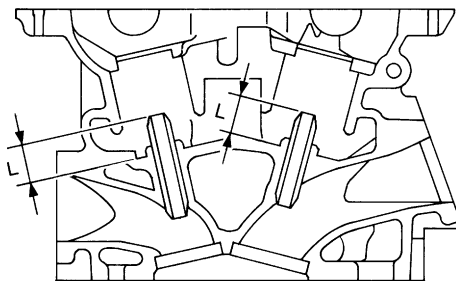

		Standard	Service
Valve guide	Outer diameter	10.023 - 10.034 (0.3946 - 0.3950)	10.223 - 10.234 (0.4025 - 0.4029)
Valve guide	Inner diameter (Finished size)	6.000 - 6.018 (0.2362 - 0.2369)	
Valve guide hole diameter		9.975 - 9.996 (0.3927 - 0.3935)	10.175 - 10.196 (0.4006 - 0.4014)
Interference fit of valve guide		0.027 - 0.059 (0.0011 - 0.0023)	
		Standard	Limit
Valve to valve guide clearance	Intake	0.020 - 0.053 (0.0008 - 0.0021)	0.08 (0.0031)
	Exhaust	0.030 - 0.063 (0.0012 - 0.0025)	0.09 (0.0035)
Valve deflection	Intake	—	0.24 (0.0094)
	Exhaust	—	0.28 (0.0110)
Projection length "L"		12.6 - 12.8 (0.496 - 0.504)	

SERVICE DATA AND SPECIFICATIONS (SDS)

Valve Seat

Unit: mm (in)

* : Machining data

*1: $45^{\circ}50' \pm 25'$

Contacting width (W)

1.09 - 1.31 (0.043 - 0.052)

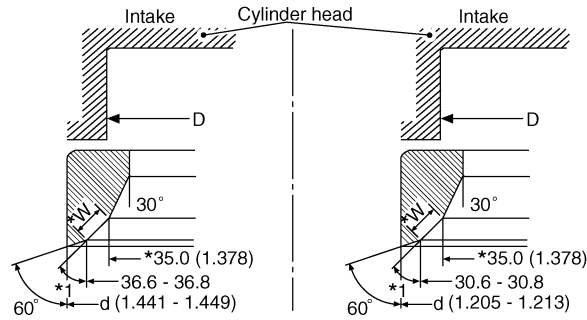

Unit: mm (in)

Contacting width (W)

1.29 - 1.51 (0.051 - 0.059)

WBIA0498E

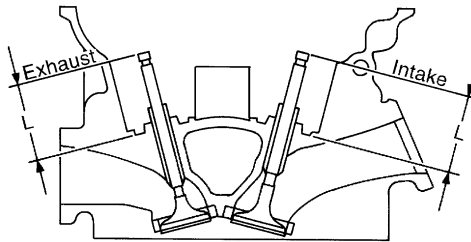

SEM621F

		Standard	Service
Cylinder head seat recess diameter (D)	Intake	38.000 - 38.016 (1.4961 - 1.4967)	38.500 - 38.516 (1.5157 - 1.5164)
	Exhaust	32.200 - 32.216 (1.2677 - 1.2683)	32.700 - 32.716 (1.2874 - 1.2880)
Valve seat interference fit	Intake	0.081 - 0.113 (0.0032 - 0.0044)	
	Exhaust	0.064 - 0.096 (0.0025 - 0.0038)	
Valve seat outer diameter (d)	Intake	38.097 - 38.113 (1.4999 - 1.5005)	38.597 - 38.613 (1.5196 - 1.5202)
	Exhaust	32.280 - 32.296 (1.2709 - 1.2715)	32.780 - 32.796 (1.2905 - 1.2912)
Height (h)	Intake	5.9 - 6.0 (0.232 - 0.236)	5.05 - 5.15 (0.1988 - 0.2028)
	Exhaust	5.9 - 6.0 (0.232 - 0.236)	4.95 - 5.05 (0.1949 - 0.1988)
Depth (H)	5.9 - 6.1 (0.232 - 0.240)		
Valve seat resurface limit (L)	Intake	41.07 - 41.67 (1.6169 - 1.6405)	
	Exhaust	41.00 - 41.60 (1.6142 - 1.6378)	

SERVICE DATA AND SPECIFICATIONS (SDS)

CAMSHAFT AND CAMSHAFT BEARING

Unit: mm (in)

	Standard	Limit
Camshaft journal to bracket clearance	No. 1 0.045 - 0.086 (0.0018 - 0.0034) No. 2, 3, 4 0.035 - 0.076 (0.0014 - 0.0030)	0.15 (0.0059)
Inner diameter of camshaft bracket	No. 1 26.000 - 26.021 (1.0236 - 1.0244) No. 2, 3, 4 23.500 - 23.521 (0.9252 - 0.9260)	—
Outer diameter of camshaft journal	No. 1 25.935 - 25.955 (1.0211 - 1.0218) No. 2, 3, 4 23.445 - 23.465 (0.9230 - 0.9238)	—
Camshaft runout [TIR*]	Less than 0.02 (0.0008)	0.05 (0.0020)
Camshaft sprocket runout [TIR*]	—	0.15 (0.0059)
Camshaft end play	0.115 - 0.188 (0.0045 - 0.0074)	0.24 (0.0094)

*: Total indicator reading

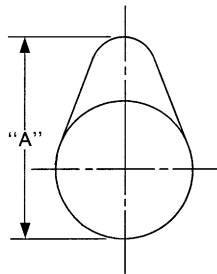

SEM671

Cam lobe height "A"	Intake and exhaust	44.865 - 45.055 (1.7663 - 1.7738)
Wear limit of cam lobe height		0.2 (0.008)

CYLINDER BLOCK

Unit: mm (in)

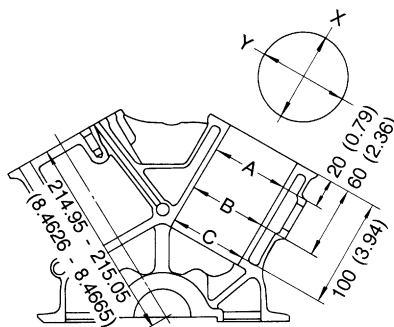

SEM022EA

Surface distortion	Limit	0.10 (0.0039)		
Cylinder bore	Inner diameter	Standard	Grade No. 1	95.500 - 95.510 (3.7598 - 3.7602)
			Grade No. 2	95.510 - 95.520 (3.7602 - 3.7606)
			Grade No. 3	95.520 - 95.530 (3.7606 - 3.7610)
		Wear limit	0.20 (0.0079)	
Main Bearing Housing	Inner Diameter	Standard	: 63.993 - 64.017 mm (2.5194 - 2.5203 in)	

SERVICE DATA AND SPECIFICATIONS (SDS)

Out-of-round (Difference between X - Y)		Less than 0.015 (0.0006)
Taper (Difference between C - A)		Less than 0.015 (0.0006)
Main journal inner diameter grade (Without bearing)	Grade No. A	63.993 - 63.994 (2.5194 - 2.5194)
	Grade No. B	63.994 - 63.995 (2.5194 - 2.5195)
	Grade No. C	63.995 - 63.996 (2.5195 - 2.5195)
	Grade No. D	63.996 - 63.997 (2.5195 - 2.5196)
	Grade No. E	63.997 - 63.998 (2.5196 - 2.5196)
	Grade No. F	63.998 - 63.999 (2.5196 - 2.5196)
	Grade No. G	63.999 - 64.000 (2.5196 - 2.5197)
	Grade No. H	64.000 - 64.001 (2.5197 - 2.5197)
	Grade No. J	64.001 - 64.002 (2.5197 - 2.5198)
	Grade No. K	64.002 - 64.003 (2.5198 - 2.5198)
	Grade No. L	64.003 - 64.004 (2.5198 - 2.5198)
	Grade No. M	64.004 - 64.005 (2.5198 - 2.5199)
	Grade No. N	64.005 - 64.006 (2.5199 - 2.5199)
	Grade No. P	64.006 - 64.007 (2.5199 - 2.5200)
	Grade No. R	64.007 - 64.008 (2.5200 - 2.5200)
	Grade No. S	64.008 - 64.009 (2.5200 - 2.5200)
	Grade No. T	64.009 - 64.010 (2.5200 - 2.5201)
	Grade No. U	64.010 - 64.011 (2.5201 - 2.5201)
	Grade No. V	64.011 - 64.012 (2.5201 - 2.5202)
Grade No. W	64.012 - 64.013 (2.5202 - 2.5202)	
Grade No. X	64.013 - 64.014 (2.5202 - 2.5202)	
Grade No. Y	64.014 - 64.015 (2.5202 - 2.5203)	
Grade No. 4	64.015 - 64.016 (2.5203 - 2.5203)	
Grade No. 7	64.016 - 64.017 (2.5203 - 2.5203)	

PISTON, PISTON RING AND PISTON PIN

Available Piston

Unit: mm (in)

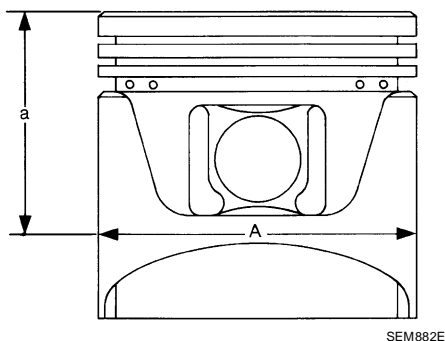

SEM882E

Piston skirt diameter "A"	Standard	Grade No. 1	95.480 - 95.490 (3.7590 - 3.7594)
		Grade No. 2	95.490 - 95.500 (3.7594 - 3.7598)
		Grade No. 3	95.500 - 95.510 (3.7598 - 3.7602)
		0.20 (0.0079) oversize (service)	95.680 - 95.710 (3.7669 - 3.7681)
"a" measuring point (distance from the top)			41.0 (1.614)
Piston pin hole diameter	Grade No. 0		21.993 - 21.999 (0.8659 - 0.8661)
	Grade No. 1		21.999 - 22.005 (0.8661 - 0.8663)
Piston-to-bore clearance to cylinder block			0.010 - 0.030 (0.0004 - 0.0012)

Piston Ring

Unit: mm (in)

		Standard	Limit
Side clearance	Top	0.045 - 0.080 (0.0018 - 0.0031)	0.11 (0.0043)
	2nd	0.030 - 0.070 (0.0012 - 0.0028)	0.1 (0.004)
	Oil ring	0.065 - 0.135 (0.0026 - 0.0053)	—

SERVICE DATA AND SPECIFICATIONS (SDS)

End gap	Top	0.23 - 0.33 (0.0091 - 0.0130)	0.54 (0.0213)
	2nd	0.33 - 0.48 (0.0130 - 0.0189)	0.80 (0.0315)
	Oil (rail ring)	0.20 - 0.50 (0.0079 - 0.0197)	0.95 (0.0374)

Piston Pin

Unit: mm (in)

Piston pin outer diameter	Grade No. 0	21.989 - 21.995 (0.8657 - 0.8659)
	Grade No. 1	21.995 - 22.001 (0.8659 - 0.8662)
Interference fit of piston pin to piston		0.002 - 0.006 (0.0001 - 0.0002)
Piston pin to connecting rod bushing oil clearance	Standard	0.005 - 0.017 (0.0002 - 0.0007)
	Limit	0.030 (0.0012)

CONNECTING ROD

Unit: mm (in)

Center distance		144.15 - 144.25 (5.6752 - 5.6791)
Bend [per 100 (3.94)]	Limit	0.15 (0.0059)
Torsion [per 100 (3.94)]	Limit	0.30 (0.0118)
Piston pin bushing inner diameter*	Grade No. 0	22.000 - 22.006 (0.8661 - 0.8664)
	Grade No. 1	22.006 - 22.012 (0.8664 - 0.8666)
Connecting rod big end inner diameter		55.000 - 55.013 (2.1654 - 2.1659)
Connecting rod side clearance	Standard	0.20 - 0.35 (0.0079 - 0.0138)
	Limit	0.40 (0.0157)

*: After installing in connecting rod

SERVICE DATA AND SPECIFICATIONS (SDS)

CRANKSHAFT

Unit: mm (in)

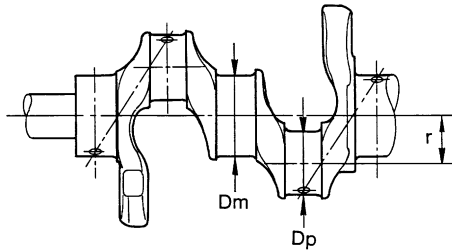

SEM645

Out-of-round (X - Y)
Taper (A - B)

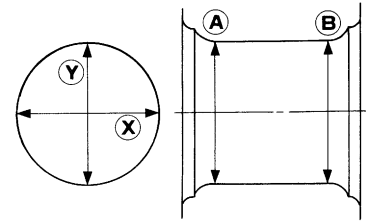

SEM715

Main journal dia. "Dm" grade	Grade No. A	59.975 - 59.974 (2.3612 - 2.3612)
	Grade No. B	59.974 - 59.973 (2.3612 - 2.3611)
	Grade No. C	59.973 - 59.972 (2.3611 - 2.3611)
	Grade No. D	59.972 - 59.971 (2.3611 - 2.3611)
	Grade No. E	59.971 - 59.970 (2.3611 - 2.3610)
	Grade No. F	59.970 - 59.969 (2.3610 - 2.3610)
	Grade No. G	59.969 - 59.968 (2.3610 - 2.3609)
	Grade No. H	59.968 - 59.967 (2.3609 - 2.3609)
	Grade No. J	59.967 - 59.966 (2.3609 - 2.3609)
	Grade No. K	59.966 - 59.965 (2.3609 - 2.3608)
	Grade No. L	59.965 - 59.964 (2.3608 - 2.3608)
	Grade No. M	59.964 - 59.963 (2.3608 - 2.3607)
	Grade No. N	59.963 - 59.962 (2.3607 - 2.3607)
	Grade No. P	59.962 - 59.961 (2.3607 - 2.3607)
	Grade No. R	59.961 - 59.960 (2.3607 - 2.3606)
	Grade No. S	59.960 - 59.959 (2.3606 - 2.3606)
	Grade No. T	59.959 - 59.958 (2.3606 - 2.3605)
Grade No. U	59.958 - 59.957 (2.3605 - 2.3605)	
Grade No. V	59.957 - 59.956 (2.3605 - 2.3605)	
Grade No. W	59.956 - 59.955 (2.3605 - 2.3604)	
Grade No. X	59.955 - 59.954 (2.3604 - 2.3604)	
Grade No. Y	59.954 - 59.953 (2.3604 - 2.3603)	
Grade No. 4	59.953 - 59.952 (2.3603 - 2.3603)	
Grade No. 7	59.952 - 59.951 (2.3603 - 2.3603)	
Pin journal dia. "Dp"	Grade No. 0	51.968 - 51.974 (2.0460 - 2.0462)
	Grade No. 1	51.962 - 51.968 (2.0457 - 2.0460)
	Grade No. 2	51.956 - 51.962 (2.0445 - 2.0457)
Center distance "r"		40.36 - 40.44 (1.5890 - 1.5921)
Out-of-round (Difference between, X - Y)	Standard	Less than 0.002 (0.0001)
Taper (Difference between, A - B)	Standard	Less than 0.002 (0.0001)
Runout [TIR*]	Limit	Less than 0.10 (0.0039)
End play	Standard	0.10 - 0.25 (0.0039 - 0.0098)
	Limit	0.30 (0.0118)

*: Total indicator reading

SERVICE DATA AND SPECIFICATIONS (SDS)

AVAILABLE MAIN BEARING

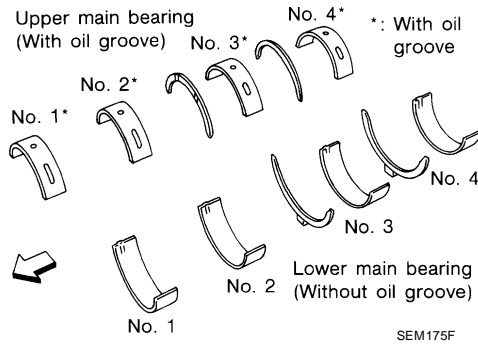

Grade number	Thickness "T" mm (in)	Width "W" mm (in)	Identification color (UPR/LWR)	Remarks	
0	2.000 - 2.003 (0.0787 - 0.0789)	19.9 - 20.1 (0.783 - 0.791)	Black	Grade is the same for upper and lower bearings.	
1	2.003 - 2.006 (0.0789 - 0.0790)		Brown		
2	2.006 - 2.009 (0.0790 - 0.0791)		Green		
3	2.009 - 2.012 (0.0791 - 0.0792)		Yellow		
4	2.012 - 2.015 (0.0792 - 0.0793)		Blue		
5	2.015 - 2.018 (0.0793 - 0.0794)		Pink		
6	2.018 - 2.021 (0.0794 - 0.0796)		Purple		
7	2.021 - 2.024 (0.0796 - 0.0797)		White	Grade is different for upper and lower bearings.	
01	UPR		2.003 - 2.006 (0.0789 - 0.0790)		Brown/Black
	LWR		2.000 - 2.003 (0.0787 - 0.0789)		
12	UPR		2.006 - 2.009 (0.0790 - 0.0791)		Green/Brown
	LWR		2.003 - 2.006 (0.0789 - 0.0790)		
23	UPR		2.009 - 2.012 (0.0791 - 0.0792)		Yellow/Green
	LWR		2.006 - 2.009 (0.0790 - 0.0791)		
34	UPR	2.012 - 2.015 (0.0792 - 0.0793)	Blue/Yellow		
	LWR	2.009 - 2.012 (0.0791 - 0.0792)			
45	UPR	2.015 - 2.018 (0.0793 - 0.0794)	Pink/Blue		
	LWR	2.012 - 2.015 (0.0792 - 0.0793)			
56	UPR	2.018 - 2.021 (0.0794 - 0.0796)	Purple/Pink		
	LWR	2.015 - 2.018 (0.0793 - 0.0794)			
67	UPR	2.021 - 2.024 (0.0796 - 0.0797)	White/Purple		
	LWR	2.018 - 2.021 (0.0794 - 0.0796)			

Undersize

Unit: mm (in)

	Thickness	Main journal diameter "Dm"
0.25 (0.0098)	2.132 - 2.140 (0.0839 - 0.0843)	Grind so that bearing clearance is the specified value.

CONNECTING ROD BEARING

Grade number	Thickness "T" mm (in)	Identification color (mark)
0	1.500 - 1.503 (0.0591 - 0.0592)	Black
1	1.503 - 1.506 (0.0592 - 0.0593)	Brown
2	1.506 - 1.509 (0.0593 - 0.0594)	Green

SERVICE DATA AND SPECIFICATIONS (SDS)

Undersize

Unit: mm (in)

	Thickness	Crank pin journal diameter "Dp"
0.25 (0.0098)	1.626 - 1.634 (0.0640 - 0.0643)	Grind so that bearing clearance is the specified value.

A

EM

BEARING CLEARANCE

Unit: mm (in)

Main bearing clearance	Standard	0.035 - 0.045 (0.0014 - 0.0018)*
	Limit	0.065 (0.0026)
Connecting rod bearing clearance	Standard	0.034 - 0.059 (0.0013 - 0.0023)*
	Limit	0.070 (0.0028)

C

D

*: Actual clearance

E

F

G

H

I

J

K

L

M

SERVICE DATA AND SPECIFICATIONS (SDS)
