

SECTION **AP**  
ADJUSTABLE PEDAL

A  
B  
C  
D  
E  
F  
G  
H  
J  
K  
L  
M

CONTENTS

<b>PRECAUTIONS</b> .....	2	Pedal Adjusting Control Unit Harness Connector	7
Precautions for Supplemental Restraint System		Terminal Layout .....	7
(SRS) "AIR BAG" and "SEAT BELT PRE-TENSIONER" .....	2	Terminal And Reference Value For Pedal Adjusting	
<b>ADJUSTABLE PEDAL SYSTEM</b> .....	3	Control Unit .....	7
Automatic Drive Positioner Adjustable Pedal .....	3	Trouble Diagnosis .....	7
Adjustable Pedal (Only Manual Operation Model)....	3	Removal and Installation .....	13

AP

# PRECAUTIONS

---

## PRECAUTIONS

PF0:00001

### Precautions for Supplemental Restraint System (SRS) “AIR BAG” and “SEAT BELT PRE-TENSIONER”

EIS007MK

The Supplemental Restraint System such as “AIR BAG” and “SEAT BELT PRE-TENSIONER”, used along with a front seat belt, helps to reduce the risk or severity of injury to the driver and front passenger for certain types of collision. This system includes seat belt switch inputs and dual stage front air bag modules. The SRS system uses the seat belt switches to determine the front air bag deployment, and may only deploy one front air bag, depending on the severity of a collision and whether the front occupants are belted or unbelted. Information necessary to service the system safely is included in the SRS and SB section of this Service Manual.

#### **WARNING:**

- To avoid rendering the SRS inoperative, which could increase the risk of personal injury or death in the event of a collision which would result in air bag inflation, all maintenance must be performed by an authorized NISSAN/INFINITI dealer.
- Improper maintenance, including incorrect removal and installation of the SRS, can lead to personal injury caused by unintentional activation of the system. For removal of Spiral Cable and Air Bag Module, see the SRS section.
- Do not use electrical test equipment on any circuit related to the SRS unless instructed to in this Service Manual. SRS wiring harnesses can be identified by yellow and/or orange harnesses or harness connectors.

# ADJUSTABLE PEDAL SYSTEM

PFP:98800

## ADJUSTABLE PEDAL SYSTEM

### Automatic Drive Positioner Adjustable Pedal

EIS007MM

Automatic drive positioner adjustable pedal. Refer to [SE-11, "AUTOMATIC DRIVE POSITIONER"](#).

### Adjustable Pedal (Only Manual Operation Model)

EIS007MN

#### COMPONENT PARTS AND HARNESS CONNECTOR LOCATION

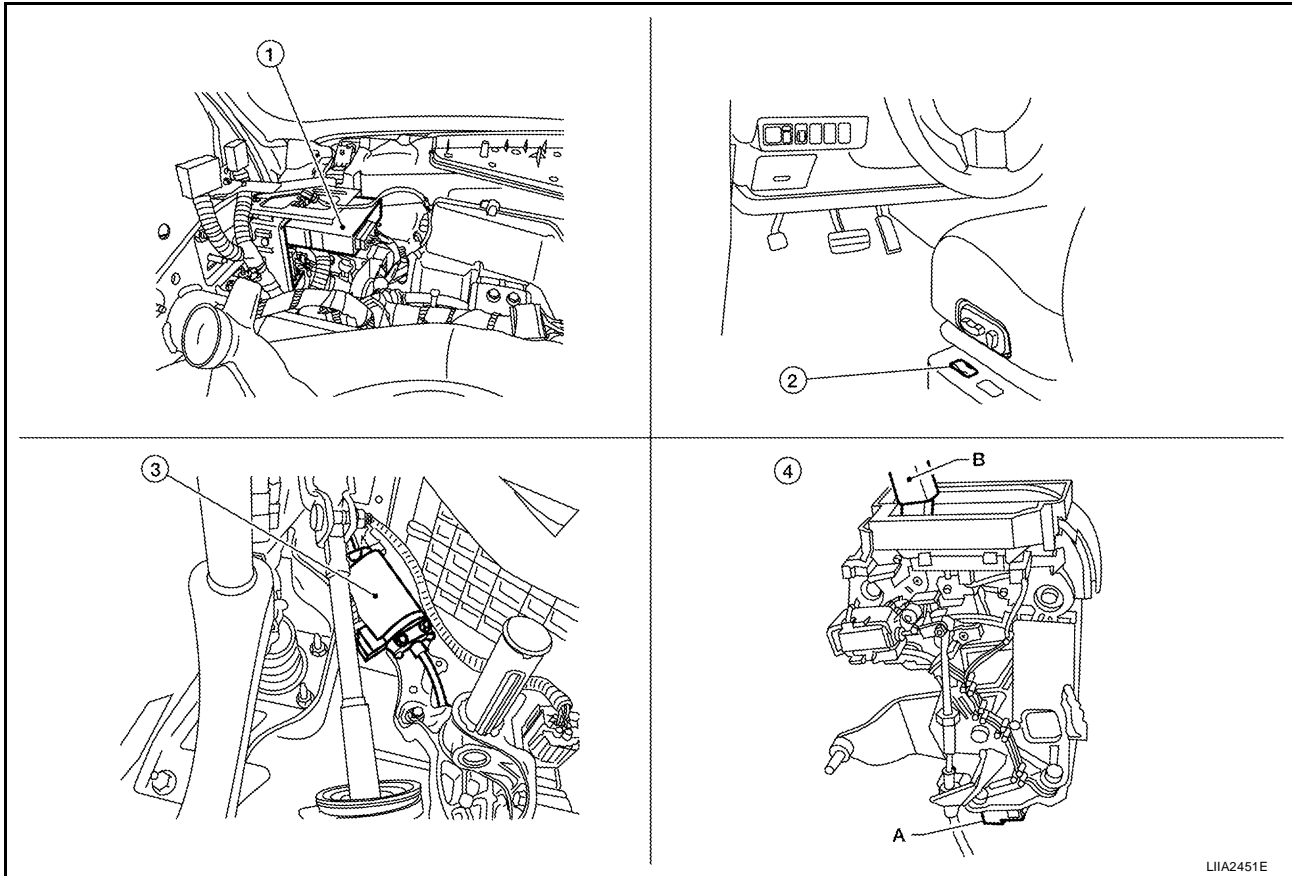

1. Pedal adjusting control unit M14 (view with instrument panel removed)
2. Pedal adjusting switch B22
3. Pedal adjusting motor E109 (view with instrument lower panel LH removed)
4. A. A/T device M34  
B. A/T selector lever (view with center console removed)

#### SYSTEM DESCRIPTION

The adjustable pedal system power supply is controlled by the pedal adjusting control unit. Power is supplied at all times

- through 40A fusible link (letter **m**, located in the fuse and fusible link box)
- to circuit breaker-2 terminal 1
- through circuit breaker-2 terminal 2
- to pedal adjusting control unit terminal 5.

With the ignition switch in ON or START, power is supplied

- through 10A fuse [No. 1, located in the fuse block (J/B)]
- to pedal adjusting control unit terminal 4.

Ground is supplied

- to pedal adjusting control unit terminal 1
- through body grounds M57, M61 and M79
- to pedal adjusting switch terminal 4
- through body grounds B7 and B19.

A  
B  
C  
D  
E  
F  
G  
H  
AP  
J  
K  
L  
M

## ADJUSTABLE PEDAL SYSTEM

---

When the A/T selector lever is shifted to P position, ground is supplied

- to pedal adjusting control unit terminal 3
- through A/T device (park position switch) terminal 7
- through A/T device (park position switch) terminal 6
- through body grounds M57, M61 and M79.

Then pedal adjusting control unit recognizes that A/T selector lever is in P position.

With power supplied, pedal adjusting switch is energized

- through pedal adjusting control unit terminal 7
- to pedal adjusting switch terminal 1.

With power supplied, pedal adjusting switch is energized.

When pedal is adjusted forward, power is supplied

- through pedal adjusting switch terminal 3
- to pedal adjusting motor terminal 1.

Then ground is supplied

- to pedal adjusting motor terminal 2
- through pedal adjusting switch terminal 2
- through pedal adjusting switch terminal 4
- through body grounds B7 and B19.

With power and ground supplied, accelerator and brake pedals move forward.

When pedal is adjusted backward, power is supplied

- through pedal adjusting switch terminal 2
- to pedal adjusting motor terminal 2.

Then ground is supplied

- to pedal adjusting motor terminal 1
- through pedal adjusting switch terminal 3
- through pedal adjusting switch terminal 4
- through body grounds B7 and B19.

With power and ground supplied, accelerator and brake pedals move backward.

# ADJUSTABLE PEDAL SYSTEM

## WIRING DIAGRAM — PEDAL —

AP-PEDAL-01

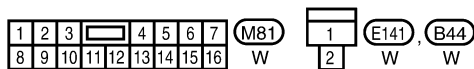
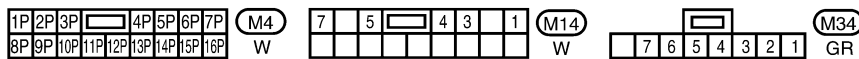
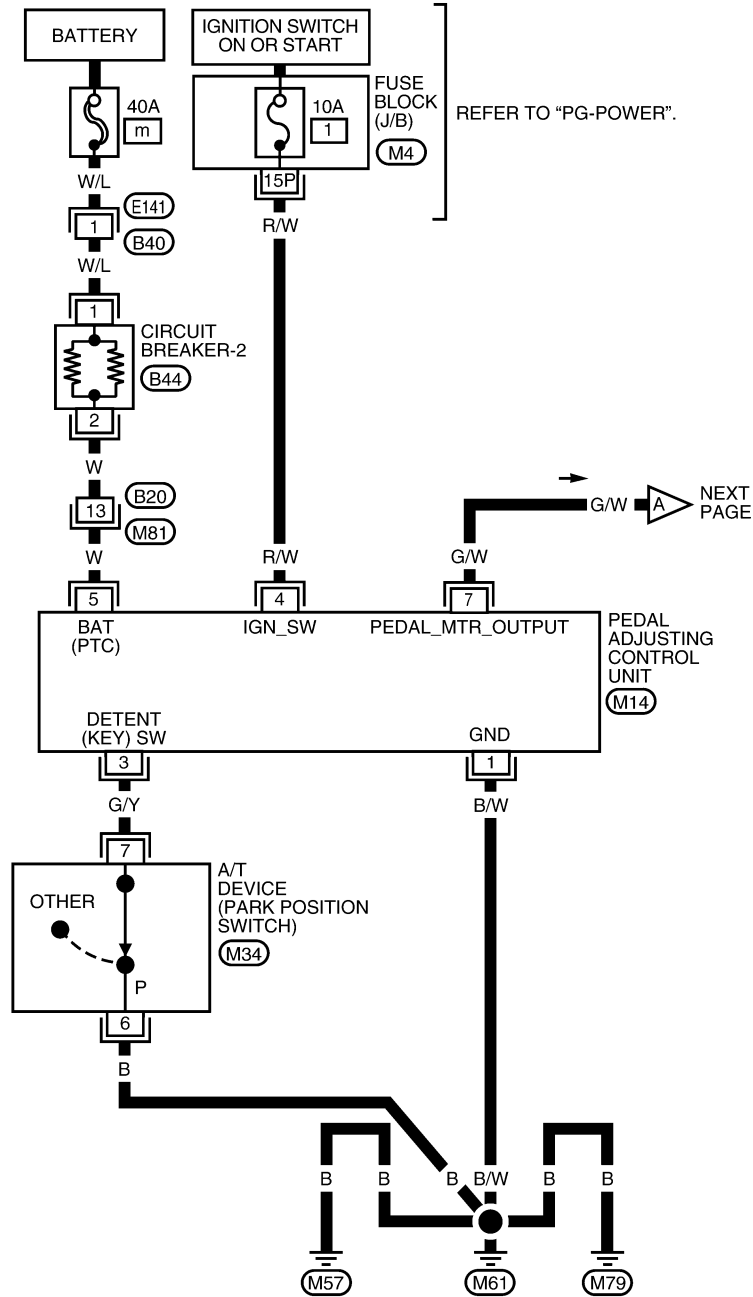

W1WA1772E

# ADJUSTABLE PEDAL SYSTEM

AP-PEDAL-02

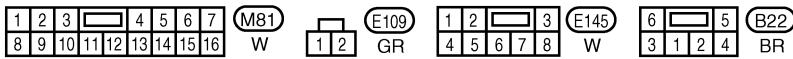
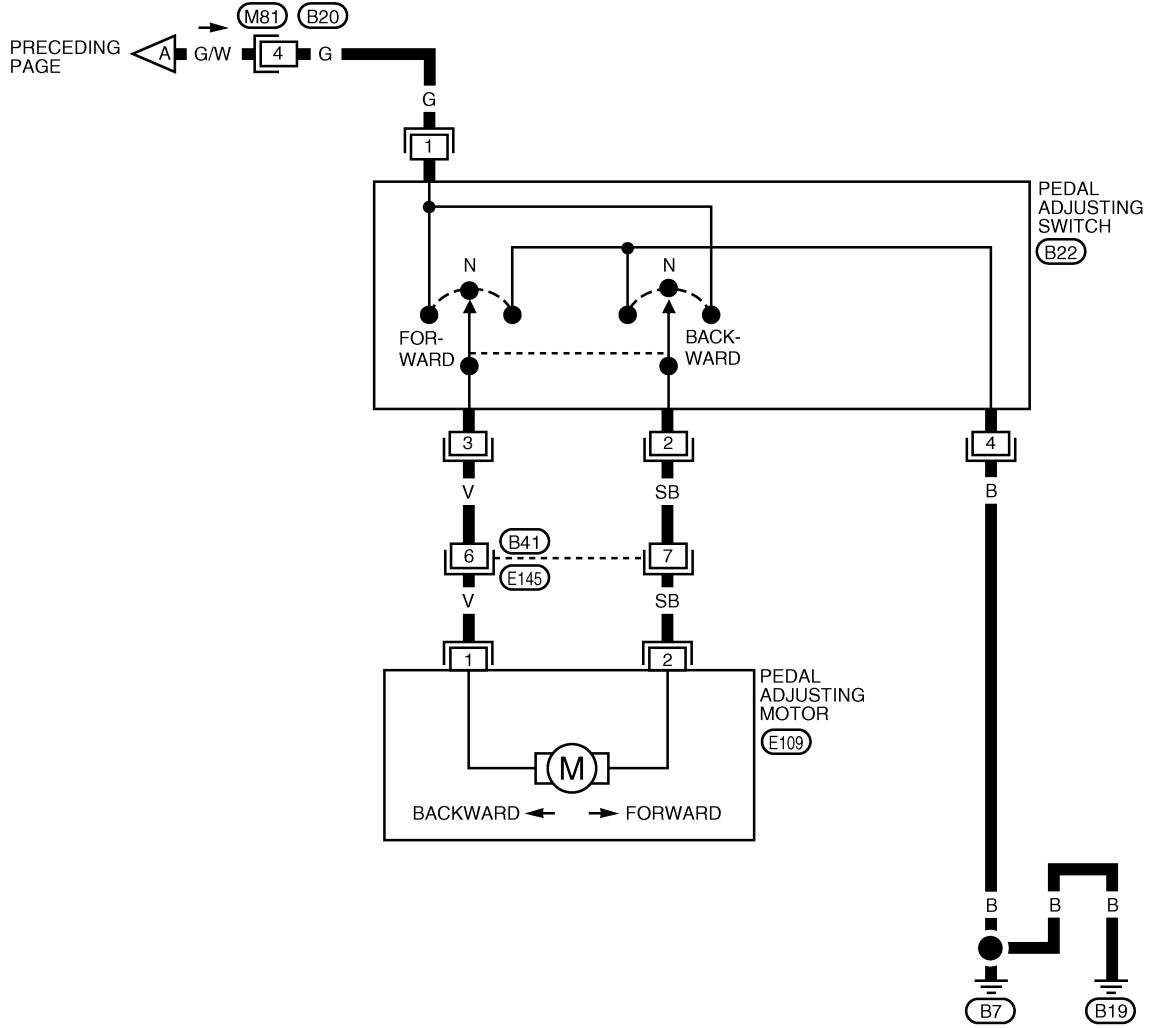

WIWA1773E

# ADJUSTABLE PEDAL SYSTEM

## Pedal Adjusting Control Unit Harness Connector Terminal Layout

EIS0099X

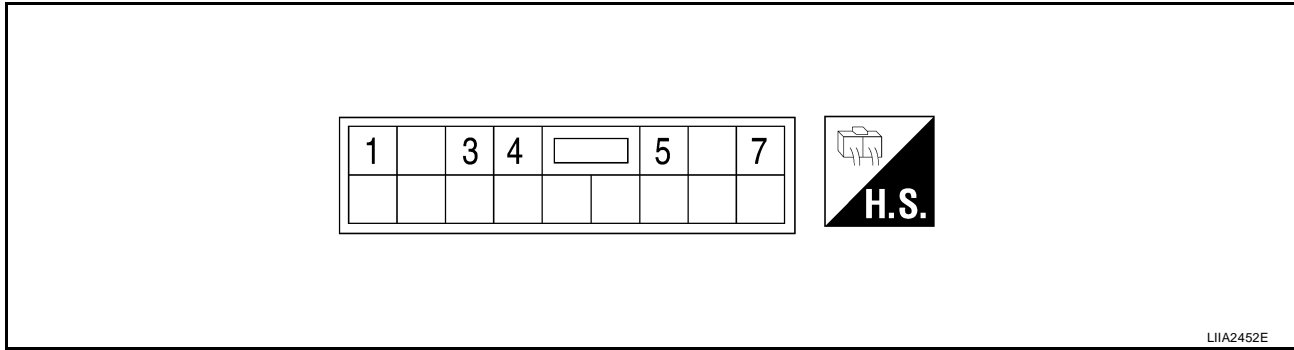

LIA2452E

## Terminal And Reference Value For Pedal Adjusting Control Unit

EIS007WT

Terminal	Wire Color	Item	Conditon	Voltage (V) (Approx.)
1	B/W	Ground	—	0
3	G/Y	A/T device (park position switch) signal	A/T selector lever in other than P position	Battery voltage
			A/T selector lever in P position	0
4	R/W	Ignition switch (ON or START)	Ignition switch (ON or START position)	Battery voltage
5	W	Battery power supply	—	Battery voltage
7	G/W	Pedal adjusting switch power supply output	Ignition switch ON A/T selector lever in other than P position	0
			Ignition switch ON A/T selector lever in P position	Battery voltage

## Trouble Diagnosis

EIS007MO

### WORK FLOW

1. Check the symptom and customer's requests.
2. Perform the preliminary check. Refer to [AP-7, "PRELIMINARY CHECK"](#) .
3. According to the trouble diagnosis chart, repair or replace the cause of the malfunction. Refer to [AP-7, "TROUBLE DIAGNOSIS CHART BY SYMPTOM"](#) .
4. Does adjustable pedal system operate normally?  
YES: GO TO 5.  
NO: GO TO 3.
5. Inspection End.

### PRELIMINARY CHECK

#### 1. CHECK ADJUSTABLE PEDAL MECHANISM

Check the following.

- Movable part of accelerator pedal or brake pedal is deformed or there is foreign material in it.
- Accelerator pedal or brake pedal is deformed or broken.

#### OK or NG

- OK >> Preliminary check is OK.  
NG >> Repair or replace the malfunctioning part and check again.

### TROUBLE DIAGNOSIS CHART BY SYMPTOM

#### NOTE:

Always check the WORK FLOW before troubleshooting. Refer to [AP-7, "WORK FLOW"](#) .

# ADJUSTABLE PEDAL SYSTEM

Symptom	Diagnosis/service procedure	Reference page
Adjustable pedal system does not operate.	1. Pedal adjusting control unit power supply and ground circuit inspection.	<a href="#">AP-9</a>
	2. Pedal adjusting switch power supply and ground circuit inspection.	<a href="#">AP-11</a>
	3. Pedal adjusting motor circuit inspection.	<a href="#">AP-12</a>
	4. Replace pedal adjusting motor.	<a href="#">AP-13</a>
Adjustable pedal system does operate when ignition switch is turned ON and A/T selector lever is in other than P position.	1. A/T device (park position switch) circuit inspection.	<a href="#">AP-10</a>
	2. Pedal adjusting control unit signal inspection.	<a href="#">AP-8</a>
	3. Replace pedal adjusting control unit.	<a href="#">AP-13</a>
Adjustable pedal system does not operate when ignition switch is turned ON and A/T selector lever is in P position.	1. A/T device (park position switch) circuit inspection.	<a href="#">AP-10</a>

## PEDAL ADJUSTING CONTROL UNIT IGNITION SIGNAL INSPECTION

### 1. CHECK FUSE

Check 10A fuse [No. 1, located in fuse block (J/B)].

#### OK or NG

OK >> GO TO 2.

NG >> If fuse is blown, be sure to eliminate cause of malfunction before installing new fuse. Refer to [PG-4, "POWER SUPPLY ROUTING CIRCUIT"](#) .

### 2. CHECK PEDAL ADJUSTING CONTROL UNIT IGNITION POWER SUPPLY CIRCUIT

1. Disconnect pedal adjusting control unit.
2. Turn ignition switch ON.
3. Check voltage between pedal adjusting control unit connector M14 terminal 4 and ground.

Connector	Terminal		Condition	Voltage (V) (Approx.)
	(+)	(-)		
M14	4	Ground	Ignition switch ON	Battery voltage
			Ignition switch OFF	0

#### OK or NG

OK >> Pedal adjusting control unit ignition signal is OK.

NG >> Repair or replace harness.

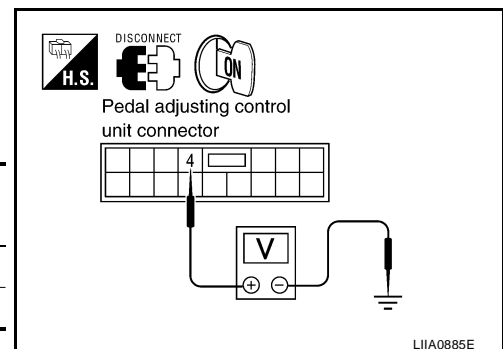



# ADJUSTABLE PEDAL SYSTEM

## PEDAL ADJUSTING CONTROL UNIT POWER SUPPLY AND GROUND INSPECTION

### 1. CHECK PEDAL ADJUSTING CONTROL UNIT OUTPUT POWER SUPPLY

1. Turn ignition switch ON.
2. Check voltage between pedal adjusting control unit connector M14 terminal 7 and ground.

Connector	Terminal		Condition	Voltage (V) (Approx.)
	(+)	(-)		
M14	7	Ground	Ignition switch ON A/T selector lever in P position	Battery voltage
			Ignition switch OFF A/T selector lever in other than P position	0

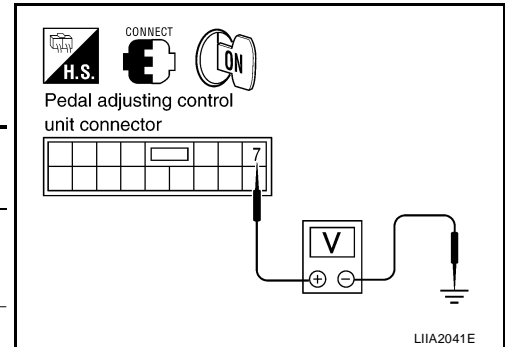

#### OK or NG

- OK >> Pedal adjusting control unit power supply and ground is OK.
- NG >> GO TO 2.

### 2. CHECK PEDAL ADJUSTING CONTROL UNIT POWER SUPPLY CIRCUIT

1. Turn ignition switch OFF.
2. Disconnect pedal adjusting control unit.
3. Check voltage between pedal adjusting control unit connector M14 terminal 5 and ground.

**5 - Ground : Battery voltage**

#### OK or NG

- OK >> GO TO 3.
- NG >> Repair or replace harness.

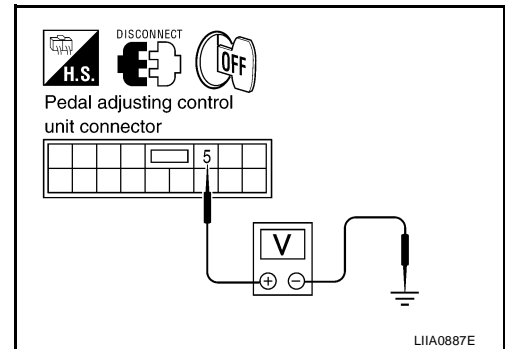

### 3. CHECK PEDAL ADJUSTING CONTROL UNIT GROUND CIRCUIT

Check continuity between pedal adjusting control unit connector M14 terminal 1 and ground.

**1 - Ground : Continuity should exist.**

#### OK or NG

- OK >> Replace pedal adjusting control unit.
- NG >> Repair or replace harness.

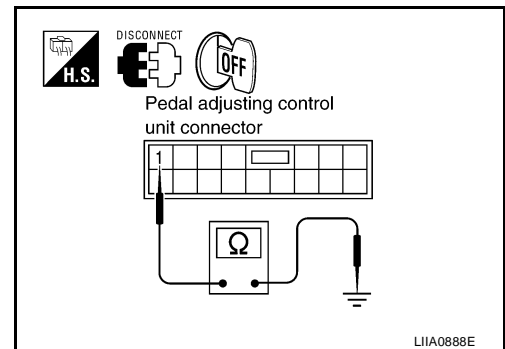

# ADJUSTABLE PEDAL SYSTEM

## A/T DEVICE (PARK POSITION SWITCH) CIRCUIT INSPECTION

### 1. CHECK FUNCTION

#### ④ With CONSULT-II

1. Refer to [GI-37, "CONSULT-II Start Procedure"](#) .
2. Check that when the A/T selector lever is in P position, "DETENT SW" on the DATA MONITOR becomes OFF.

Monitor item [OPERATION or UNIT]		Contents
DETENT SW	"ON/ OFF"	The A/T selector lever position "P position (OFF)/other than P position (ON)" judged from the A/T device (park position switch) signal is displayed.

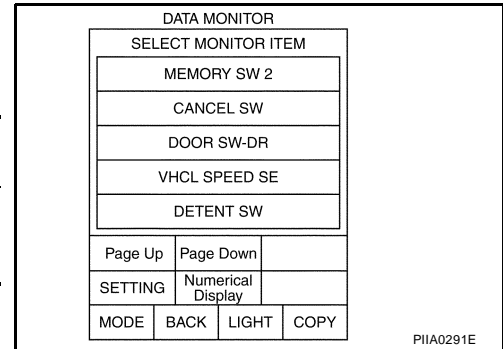

#### ⊗ Without CONSULT-II

GO TO 2.

OK or NG

- OK >> A/T device (park position switch) circuit is OK.
- NG >> GO TO 2.

### 2. CHECK A/T DEVICE (PARK POSITION SWITCH) HARNESS

1. Disconnect pedal adjusting control unit.
2. Check continuity between pedal adjusting control unit connector M14 terminal 3 and A/T device connector M34 terminal 7.

**3 - 7 : Continuity should exist.**

3. Check continuity between pedal adjusting control unit connector M14 terminal 3 and ground.

**3 - Ground : Continuity should not exist.**

OK or NG

- OK >> GO TO 3.
- NG >> Repair or replace harness.

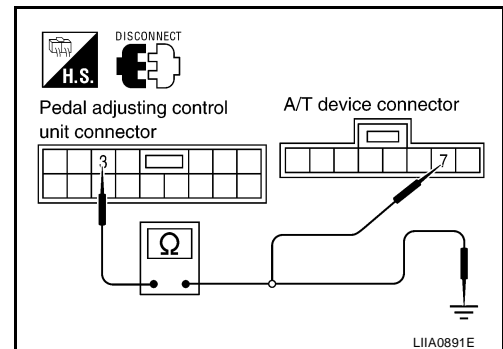

### 3. CHECK A/T DEVICE (PARK POSITION SWITCH)

Check continuity between A/T device terminals 6 and 7.

Terminals	Condition	Continuity
6   7	P position	Yes
	Other than P position	No

OK or NG

- OK >> GO TO 4.
- NG >> Replace A/T device. Refer to [AT-230, "CONTROL DEVICE"](#) .

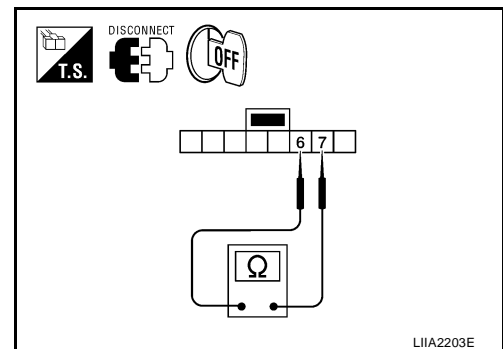

# ADJUSTABLE PEDAL SYSTEM

## 4. CHECK A/T DEVICE GROUND CIRCUIT

Check continuity between A/T device connector M34 terminal 6 and ground.

**6 - Ground : Continuity should exist.**

OK or NG

- OK >> Replace pedal adjusting control unit.
- NG >> Repair or replace harness.

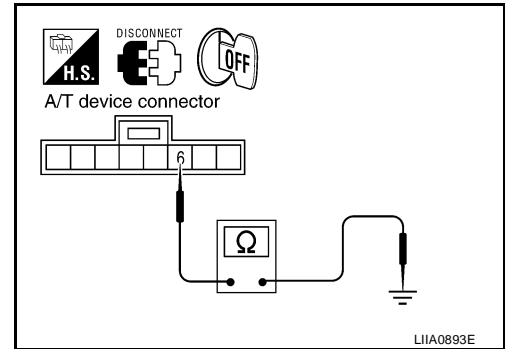

## PEDAL ADJUSTING SWITCH POWER SUPPLY AND GROUND INSPECTION

### 1. CHECK PEDAL ADJUSTING SWITCH POWER SUPPLY

1. Turn ignition switch OFF.
2. Disconnect pedal adjusting switch connector.
3. Check voltage between pedal adjusting switch connector B22 terminal 1 and ground.

**1 - Ground : Battery voltage**

OK or NG

- OK >> GO TO 3.
- NG >> GO TO 2.

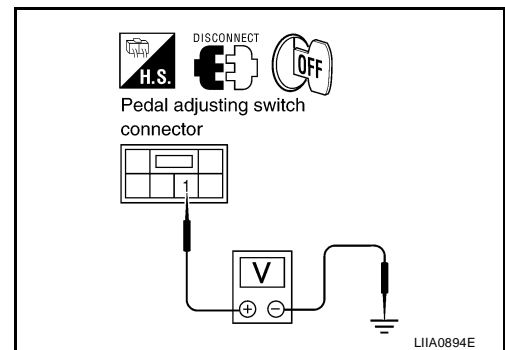

### 2. CHECK PEDAL ADJUSTING SWITCH HARNESS

1. Disconnect pedal adjusting control unit.
  2. Check continuity between pedal adjusting control unit connector M14 terminal 7 and pedal adjusting switch connector B22 terminal 1.
- 7 - 1 : Continuity should exist.**
3. Check continuity between pedal adjusting control unit connector M14 terminal 7 and ground.

**7 - Ground : Continuity should not exist.**

OK or NG

- OK >> Replace pedal adjusting control unit.
- NG >> Repair or replace harness.

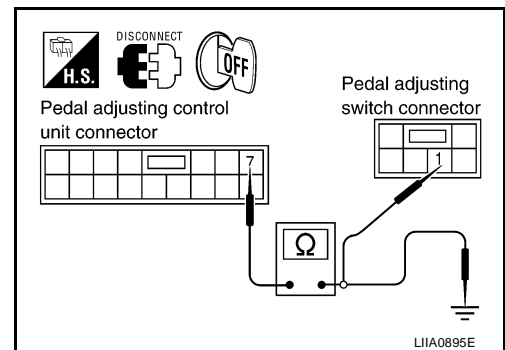

### 3. CHECK PEDAL ADJUSTING SWITCH GROUND CIRCUIT

Check continuity between pedal adjusting switch connector B22 terminal 4 and ground.

**4 - Ground : Continuity should exist.**

OK or NG

- OK >> Replace pedal adjusting switch.
- NG >> Repair or replace harness.

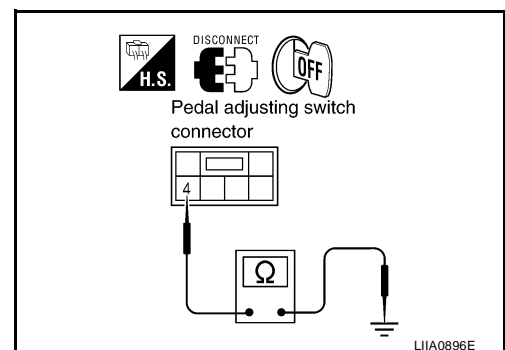

# ADJUSTABLE PEDAL SYSTEM

## PEDAL ADJUSTING MOTOR CIRCUIT INSPECTION

### 1. CHECK PEDAL ADJUSTING SWITCH

1. Turn ignition switch OFF.
2. Disconnect pedal adjusting switch.
3. Check continuity between pedal adjusting switch terminals as follows.

Terminals	Condition	Continuity
3	1	Pedal adjusting switch forward. Yes
		Pedal adjusting switch neutral. No
	4	Pedal adjusting switch backward. Yes
		Pedal adjusting switch neutral. No
2	1	Pedal adjusting switch backward. Yes
		Pedal adjusting switch neutral. No
	4	Pedal adjusting switch forward. Yes
		Pedal adjusting switch neutral. No

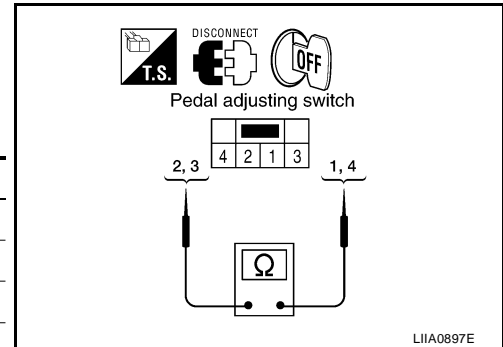

#### OK or NG

- OK >> GO TO 2.  
 NG >> Replace pedal adjusting switch.

### 2. CHECK PEDAL ADJUSTING MOTOR HARNESS

1. Disconnect pedal adjusting motor.
2. Check continuity between pedal adjusting switch connector B22 terminals 2, 3 and pedal adjusting motor connector E109 terminals 1, 2.

**2 - 2 : Continuity should exist.**

**3 - 1 : Continuity should exist.**

3. Check continuity between pedal adjusting switch connector B22 terminals 2, 3 and ground.

**2 - Ground : Continuity should not exist.**

**3 - Ground : Continuity should not exist.**

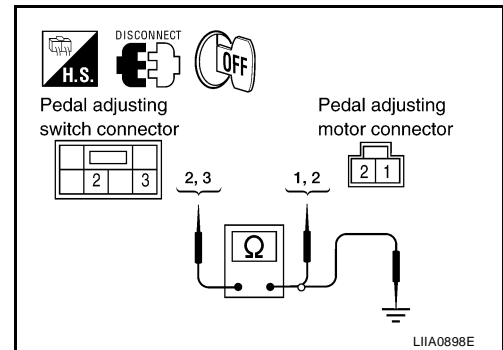

#### OK or NG

- OK >> Replace pedal adjusting motor. Refer to [ACC-5, "ADJUSTABLE PEDAL ELECTRIC MOTOR"](#) .  
 NG >> Repair or replace harness.

# ADJUSTABLE PEDAL SYSTEM

## Removal and Installation

EIS007MP

Refer to [ACC-3, "ACCELERATOR CONTROL SYSTEM"](#) and [BR-6, "BRAKE PEDAL"](#) .

A

B

C

D

E

F

G

H

AP

J

K

L

M

# ADJUSTABLE PEDAL SYSTEM

---