

SECTION **PG**

POWER SUPPLY, GROUND & CIRCUIT ELEMENTS

CONTENTS

PRECAUTIONS	3	GROUND CIRCUIT	30
Precautions for Supplemental Restraint System (SRS) "AIR BAG" and "SEAT BELT PRE-TENSIONER"	3	Ground Distribution	30
Wiring Diagrams and Trouble Diagnosis	3	MAIN HARNESS	30
POWER SUPPLY ROUTING CIRCUIT	4	ENGINE ROOM HARNESS	32
Schematic	4	ENGINE CONTROL HARNESS	35
Wiring Diagram — POWER —	6	BODY HARNESS	36
BATTERY POWER SUPPLY — IGNITION SW. IN ANY POSITION	6	BODY NO. 2 HARNESS	38
ACCESSORY POWER SUPPLY — IGNITION SW. IN ACC OR ON	10	BACK DOOR NO. 2 HARNESS	39
IGNITION POWER SUPPLY — IGNITION SW. IN ON	11	HARNESS	40
IGNITION POWER SUPPLY — IGNITION SW. IN ON AND/OR START	12	Harness Layout	40
IPDM E/R (INTELLIGENT POWER DISTRIBUTION MODULE ENGINE ROOM)	15	HOW TO READ HARNESS LAYOUT	40
System Description	15	OUTLINE	41
SYSTEMS CONTROLLED BY IPDM E/R	15	MAIN HARNESS	42
CAN COMMUNICATION LINE CONTROL	15	ENGINE ROOM HARNESS (LH VIEW)	44
IPDM E/R STATUS CONTROL	17	ENGINE ROOM HARNESS (RH VIEW)	47
CAN Communication System Description	17	ENGINE CONTROL HARNESS	50
Function of Detecting Ignition Relay Malfunction ...	17	BODY HARNESS	52
CONSULT-II Function (IPDM E/R)	18	BODY NO. 2 HARNESS	54
CONSULT-II BASIC OPERATION	18	ROOM LAMP HARNESS	56
SELF-DIAGNOSTIC RESULTS	19	FRONT DOOR LH HARNESS	57
DATA MONITOR	19	FRONT DOOR RH HARNESS	57
ACTIVE TEST	21	SLIDING DOOR LH HARNESS	58
Auto Active Test	22	SLIDING DOOR RH HARNESS	58
DESCRIPTION	22	BACK DOOR HARNESS	59
OPERATION PROCEDURE	22	Wiring Diagram Codes (Cell Codes)	60
INSPECTION IN AUTO ACTIVE TEST MODE... ..	23	ELECTRICAL UNITS LOCATION	63
Schematic	25	Electrical Units Location	63
IPDM E/R Terminal Arrangement	26	ENGINE COMPARTMENT	63
IPDM E/R Power/Ground Circuit Inspection	27	PASSENGER COMPARTMENT	64
Inspection with CONSULT-II (Self-Diagnosis)	28	Fuse	66
Removal and Installation of IPDM E/R	29	Fusible Link	66
REMOVAL	29	Circuit Breaker (Built Into BCM)	66
INSTALLATION	29	HARNESS CONNECTOR	67
		Description	67
		HARNESS CONNECTOR (TAB-LOCKING TYPE)	67
		HARNESS CONNECTOR (SLIDE-LOCKING TYPE)	68
		HARNESS CONNECTOR (DIRECT-CONNECT SRS COMPONENT TYPE)	69

ELECTRICAL UNITS	70	SUPER MULTIPLE JUNCTION (SMJ)	73
Terminal Arrangement	70	Terminal Arrangement	73
STANDARDIZED RELAY	71	FUSE BLOCK-JUNCTION BOX (J/B)	74
Description	71	Terminal Arrangement	74
NORMAL OPEN, NORMAL CLOSED AND		FUSE AND FUSIBLE LINK BOX	75
MIXED TYPE RELAYS	71	Terminal Arrangement	75
TYPE OF STANDARDIZED RELAYS	71		

PRECAUTIONS

PRECAUTIONS

PFP:00011

Precautions for Supplemental Restraint System (SRS) “AIR BAG” and “SEAT BELT PRE-TENSIONER”

EKS006F6

The Supplemental Restraint System such as “AIR BAG” and “SEAT BELT PRE-TENSIONER”, used along with a front seat belt, helps to reduce the risk or severity of injury to the driver and front passenger for certain types of collision. This system includes seat belt switch inputs and dual stage front air bag modules. The SRS system uses the seat belt switches to determine the front air bag deployment, and may only deploy one front air bag, depending on the severity of a collision and whether the front occupants are belted or unbelted. Information necessary to service the system safely is included in the SRS and SB section of this Service Manual.

WARNING:

- To avoid rendering the SRS inoperative, which could increase the risk of personal injury or death in the event of a collision which would result in air bag inflation, all maintenance must be performed by an authorized NISSAN/INFINITI dealer.
- Improper maintenance, including incorrect removal and installation of the SRS, can lead to personal injury caused by unintentional activation of the system. For removal of Spiral Cable and Air Bag Module, see the SRS section.
- Do not use electrical test equipment on any circuit related to the SRS unless instructed to in this Service Manual. SRS wiring harnesses can be identified by yellow and/or orange harnesses or harness connectors.

Wiring Diagrams and Trouble Diagnosis

EKS006F8

When you read wiring diagrams, refer to the following:

- Refer to [GI-13, "How to Read Wiring Diagrams"](#) in GI section.
- Refer to [PG-4, "POWER SUPPLY ROUTING CIRCUIT"](#) for power distribution.

When you perform trouble diagnosis, refer to the following:

- Refer to [GI-10, "HOW TO FOLLOW TEST GROUPS IN TROUBLE DIAGNOSES"](#) in GI section.
- Refer to [GI-25, "How to Perform Efficient Diagnosis for an Electrical Incident"](#) in GI section.

A

B

C

D

E

F

G

H

I

J

PG

L

M

POWER SUPPLY ROUTING CIRCUIT

PF:24110

EKS0064B

POWER SUPPLY ROUTING CIRCUIT

Schematic

For detailed ground distribution, refer to [PG-30, "Ground Distribution"](#).

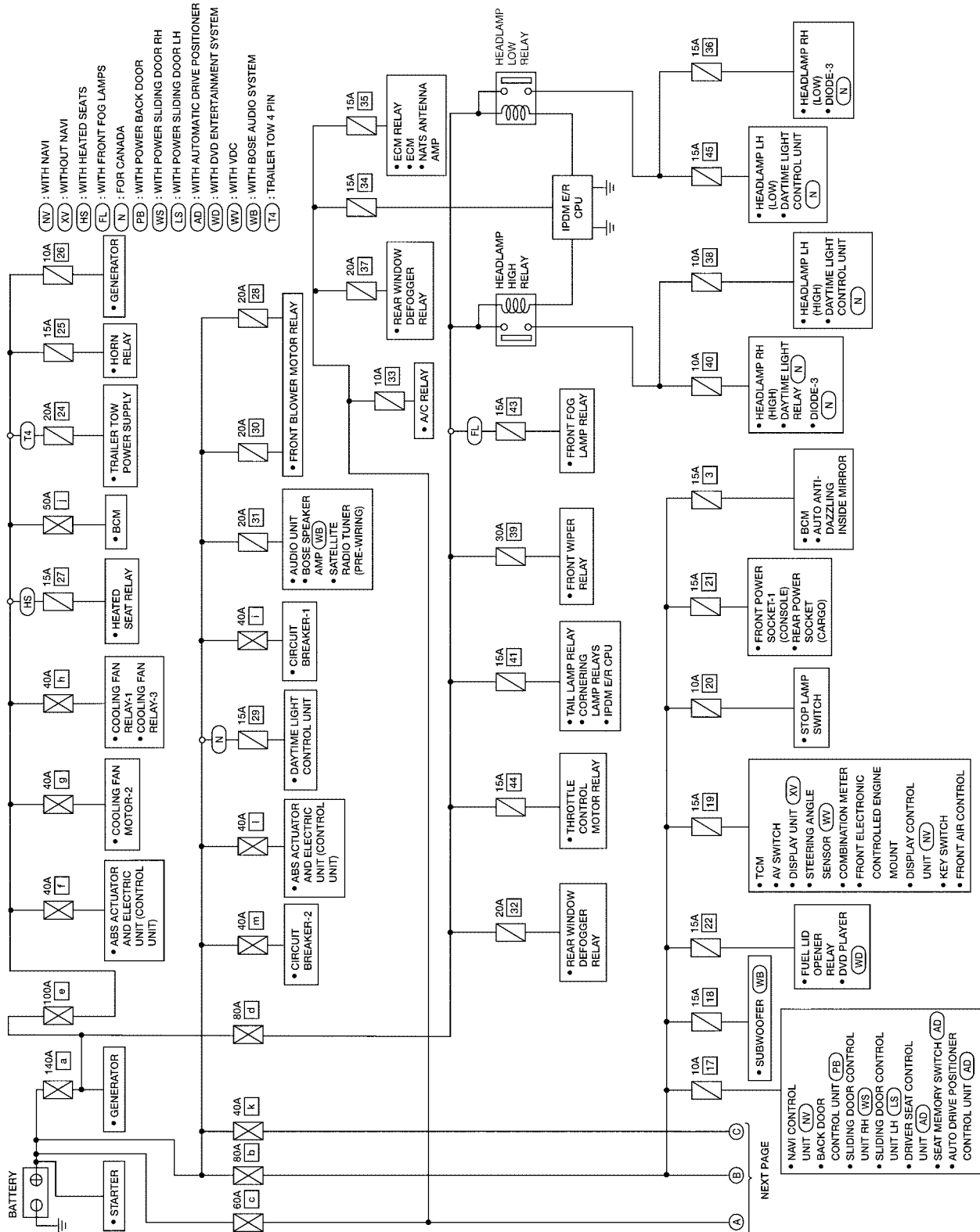

WKWA2246E

POWER SUPPLY ROUTING CIRCUIT

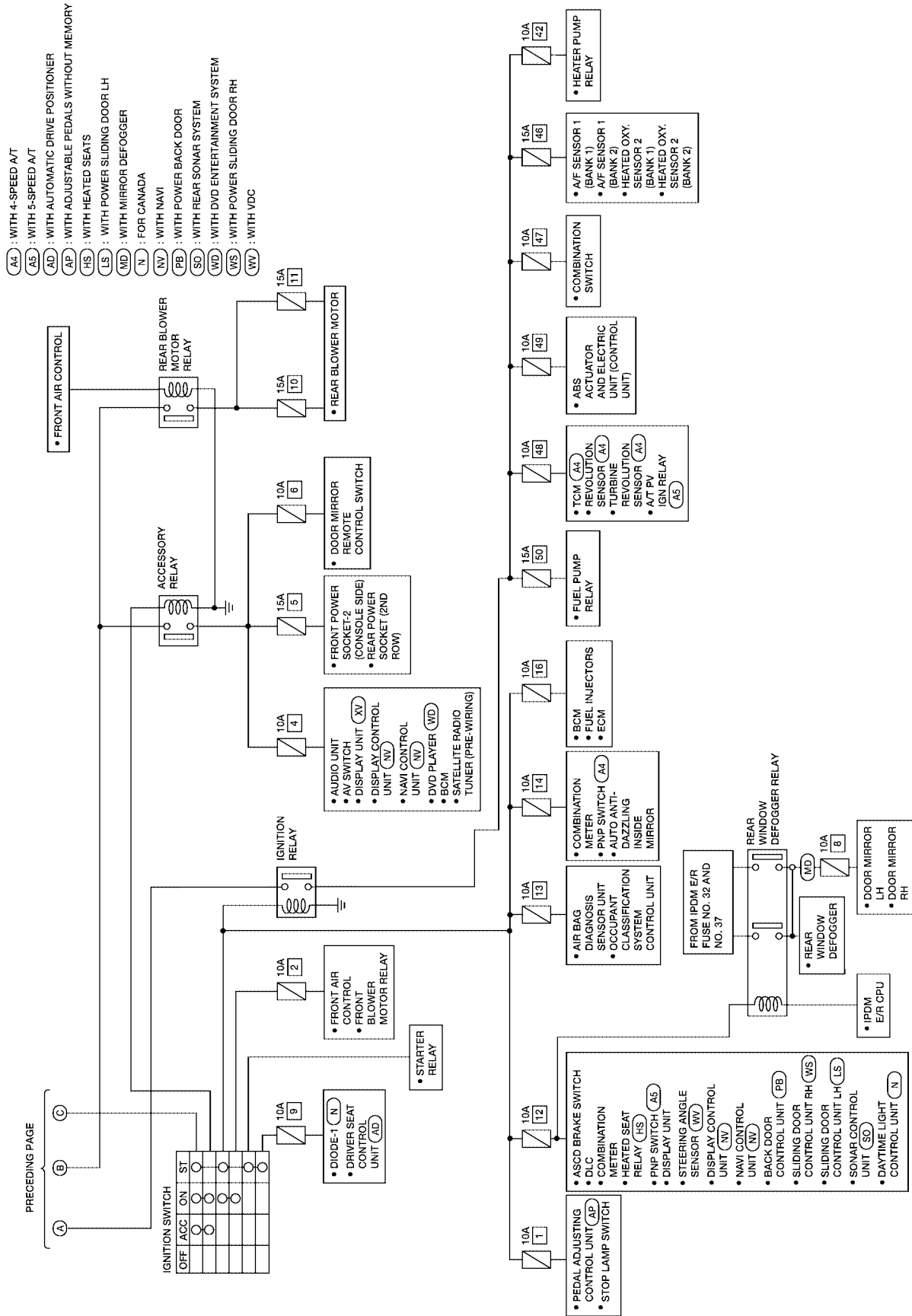

POWER SUPPLY ROUTING CIRCUIT

EKS0064C

Wiring Diagram — POWER — BATTERY POWER SUPPLY — IGNITION SW. IN ANY POSITION

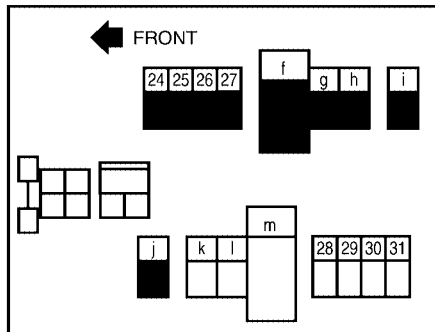
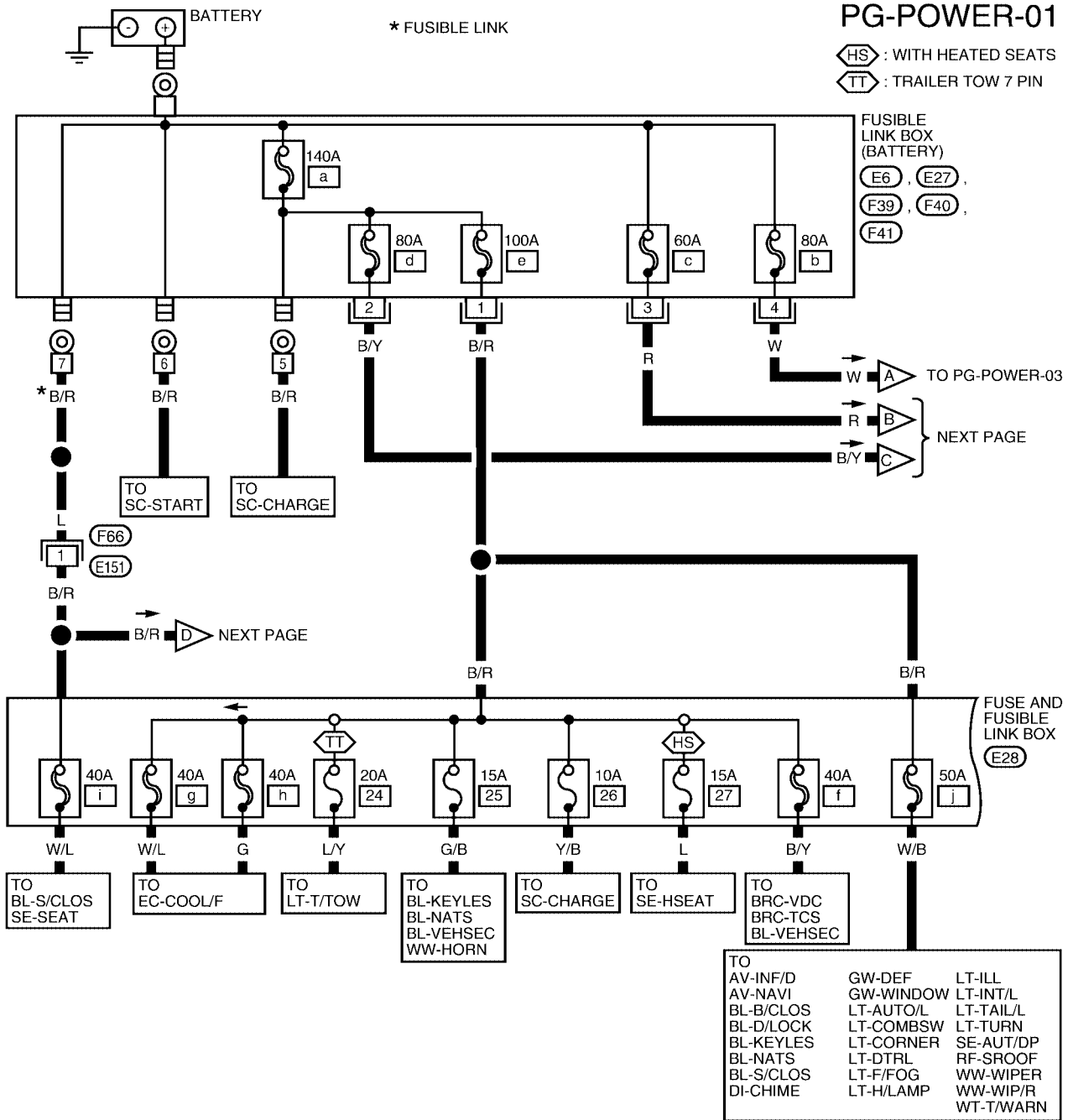

E28

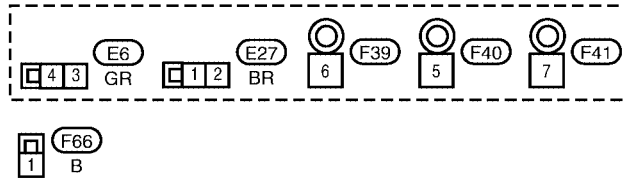

WKWA3991E

POWER SUPPLY ROUTING CIRCUIT

PG-POWER-02

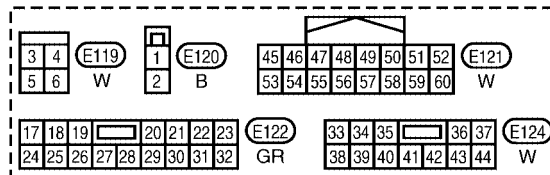
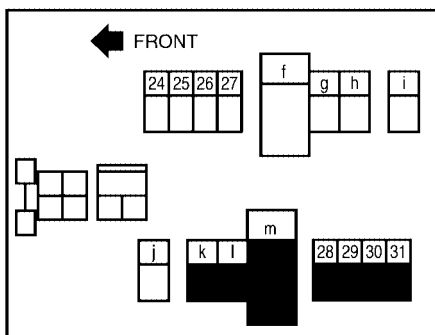
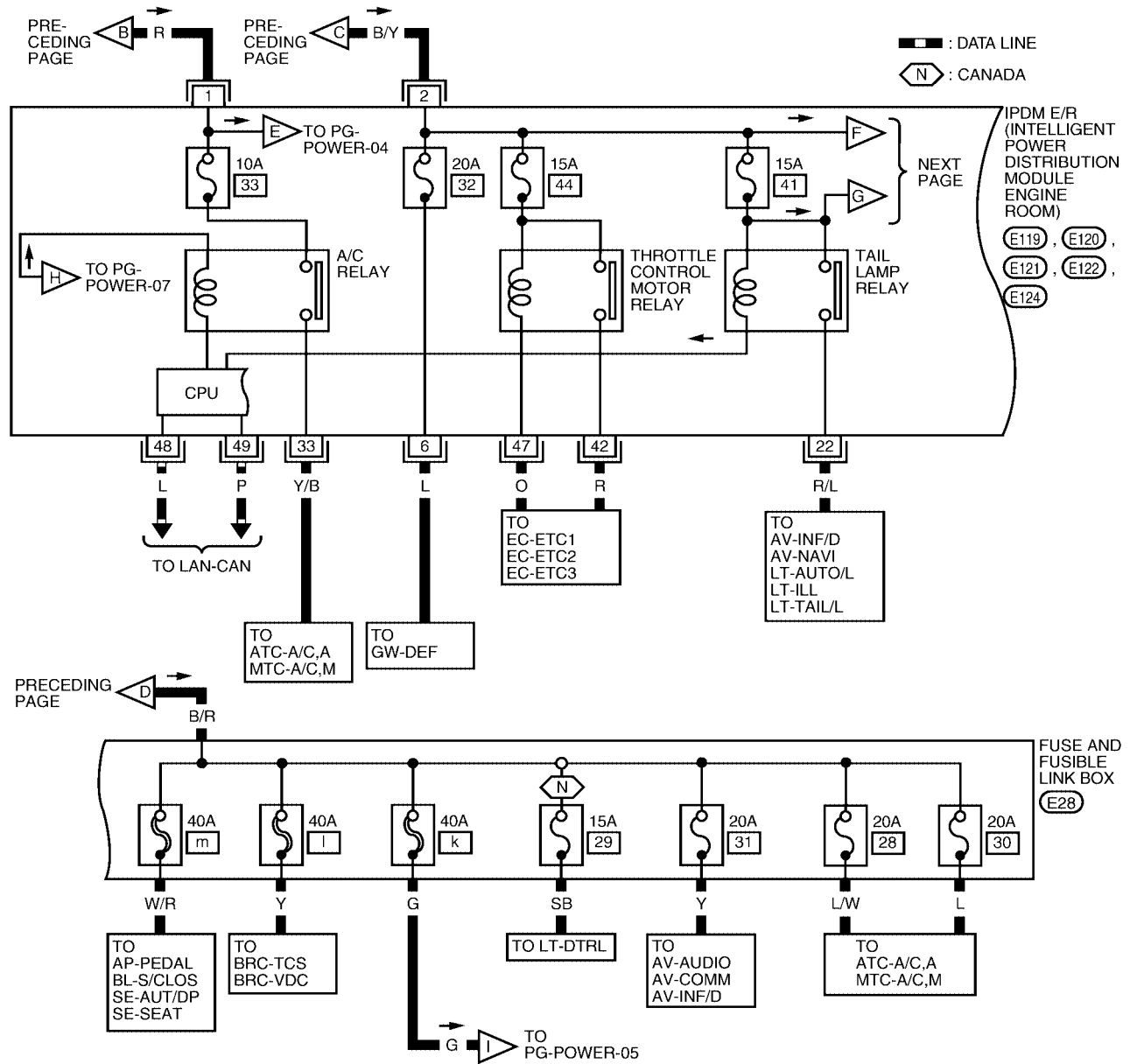

WKWA3992E

POWER SUPPLY ROUTING CIRCUIT

PG-POWER-03

⬠ : WITH FRONT FOG LAMPS

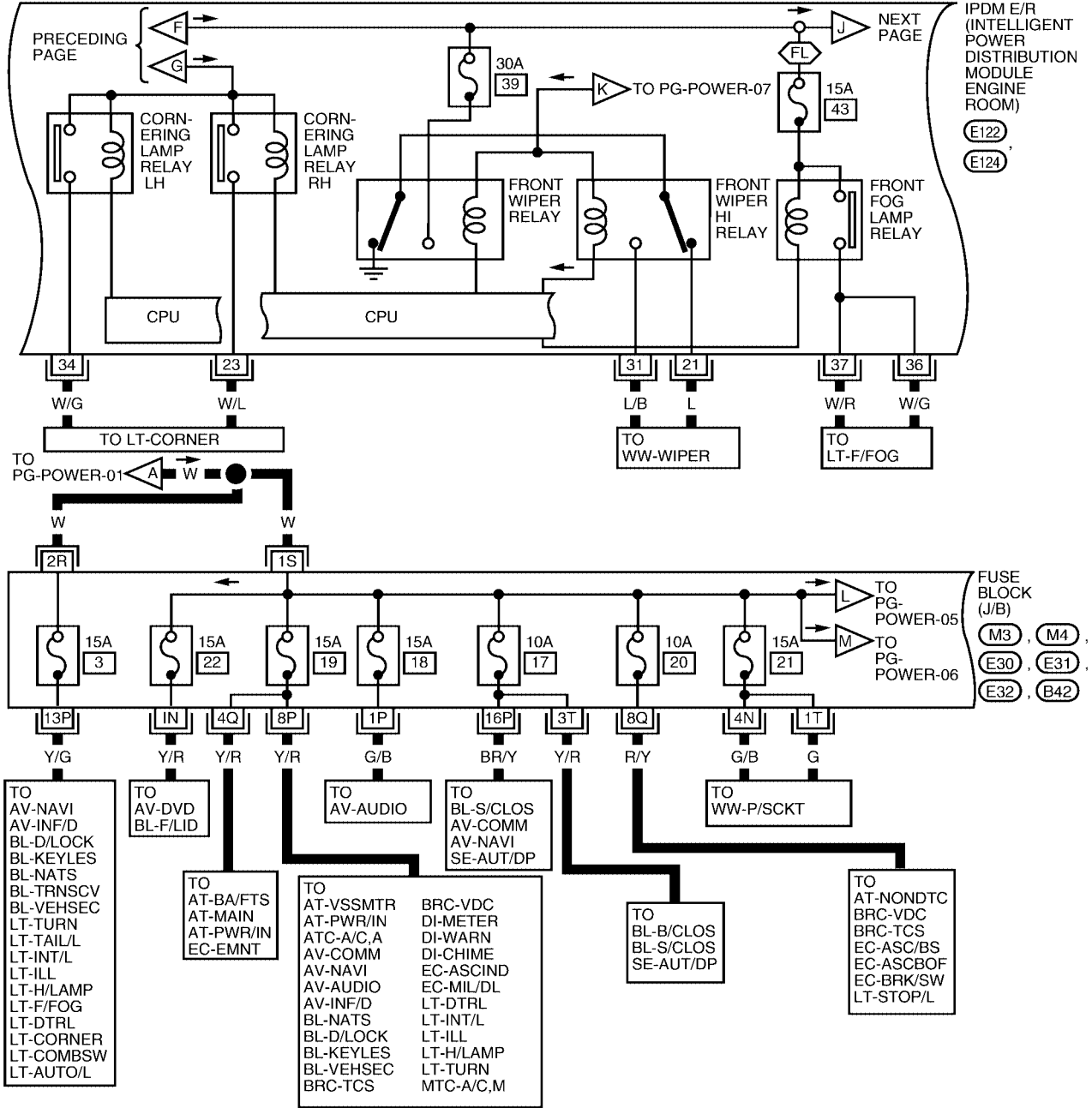

17	18	19	20	21	22	23	E122	33	34	34	36	37	E124		
24	25	26	27	28	29	30	GR	38	39	40	41	42	43	44	W

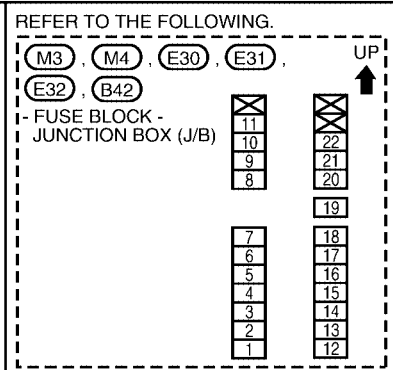

WKWA3993E

POWER SUPPLY ROUTING CIRCUIT

PG-POWER-04

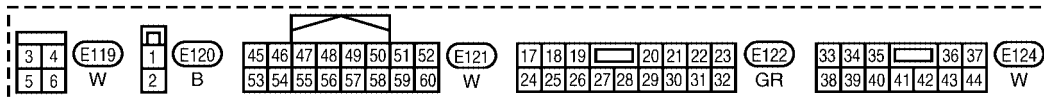
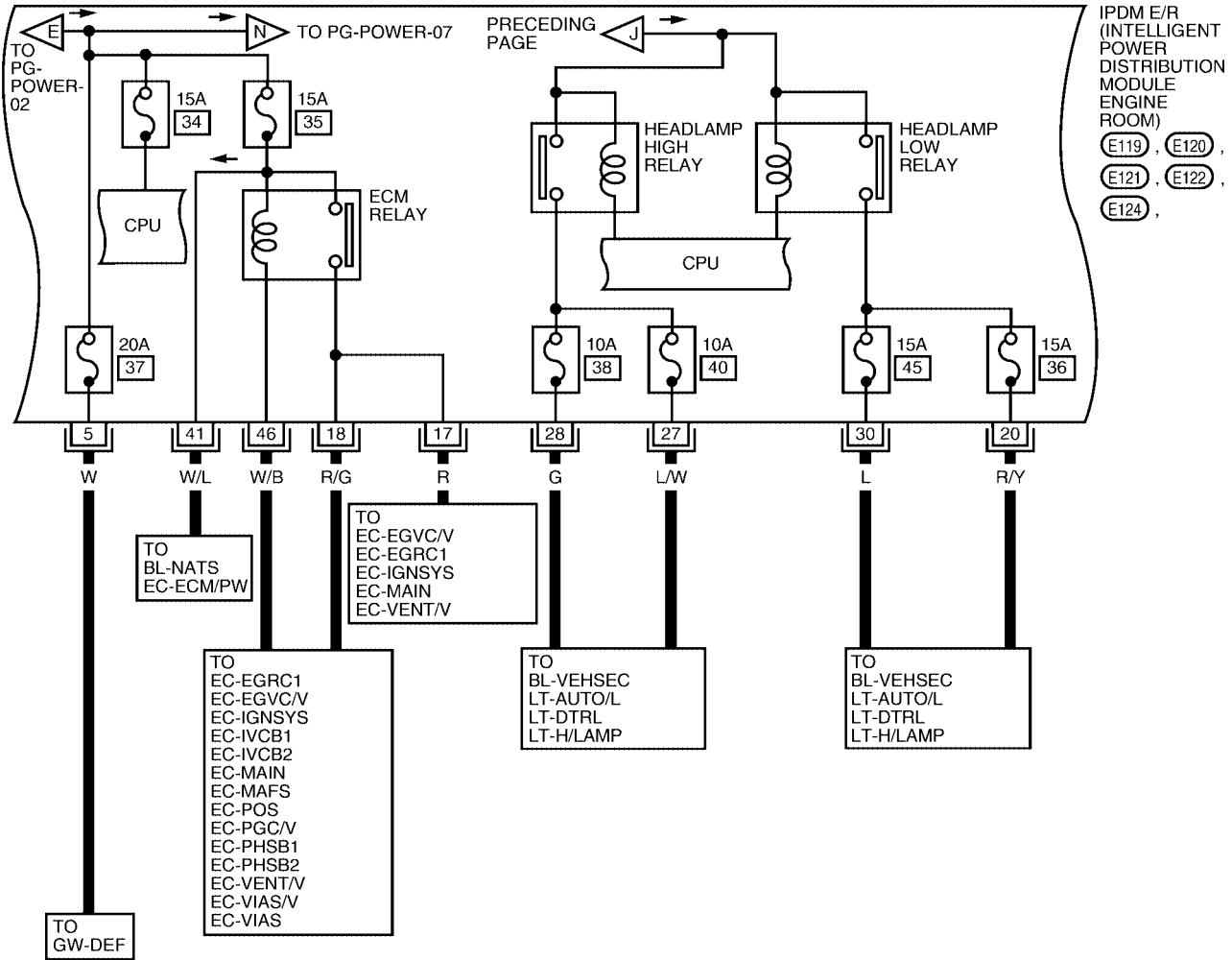

POWER SUPPLY ROUTING CIRCUIT

ACCESSORY POWER SUPPLY — IGNITION SW. IN ACC OR ON

PG-POWER-05

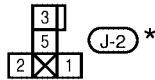
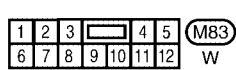
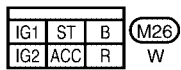
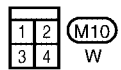
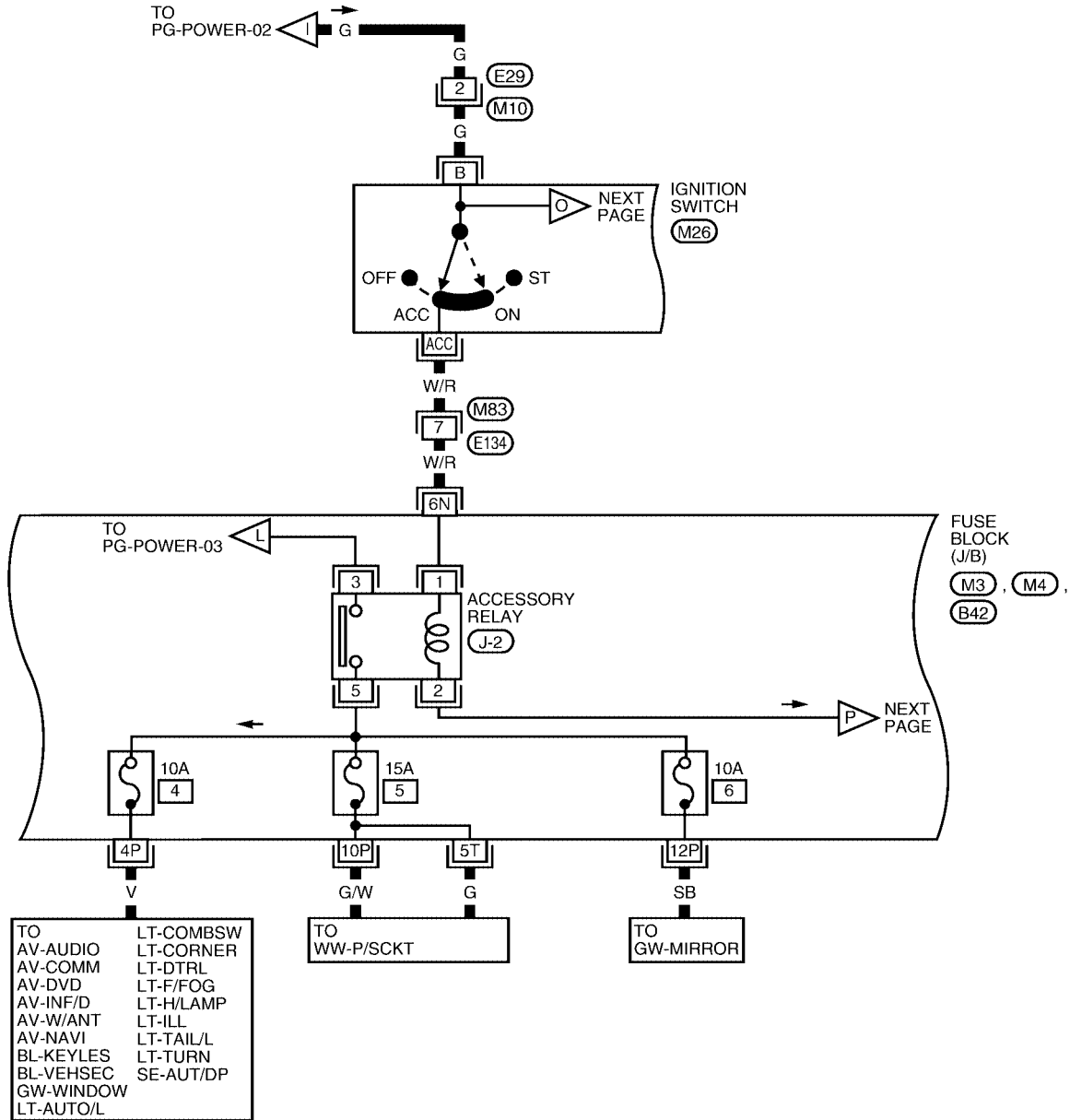

*: THIS CONNECTOR IS NOT SHOWN IN "HARNESS LAYOUT".

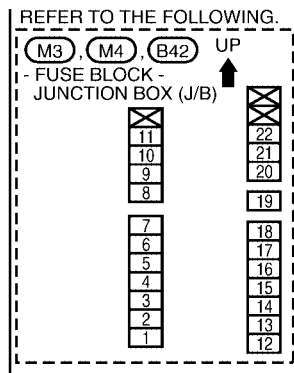

WKWA2252E

POWER SUPPLY ROUTING CIRCUIT

IGNITION POWER SUPPLY — IGNITION SW. IN ON

PG-POWER-06

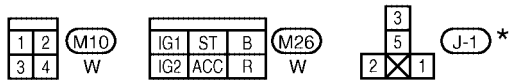
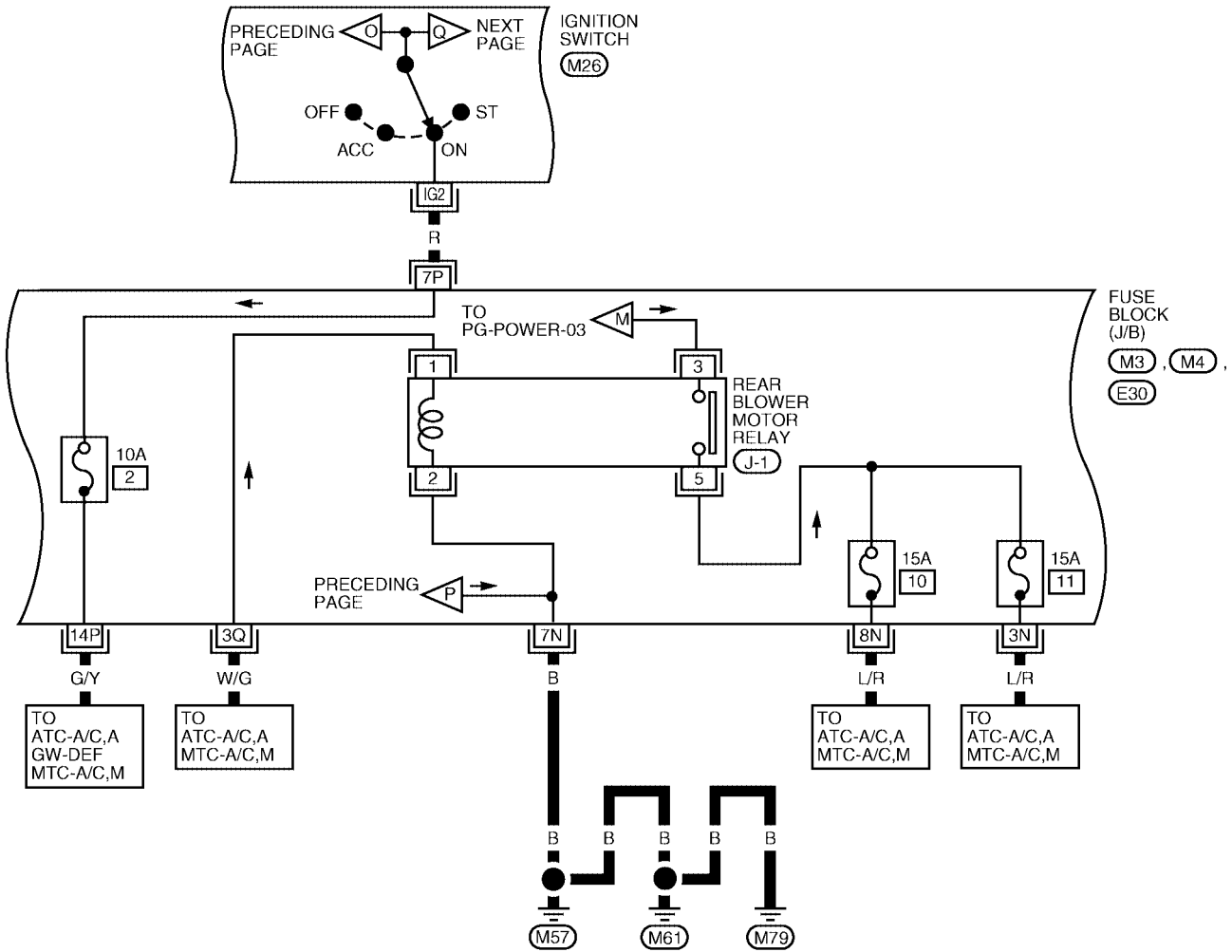

*: THIS CONNECTOR IS NOT SHOWN IN "HARNESS LAYOUT".

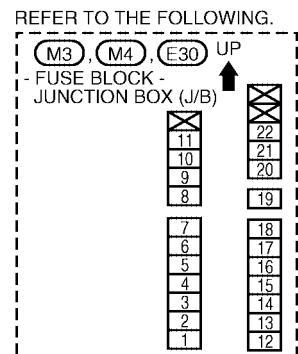

WKWA1709E

POWER SUPPLY ROUTING CIRCUIT

IGNITION POWER SUPPLY — IGNITION SW. IN ON AND/OR START

PG-POWER-07

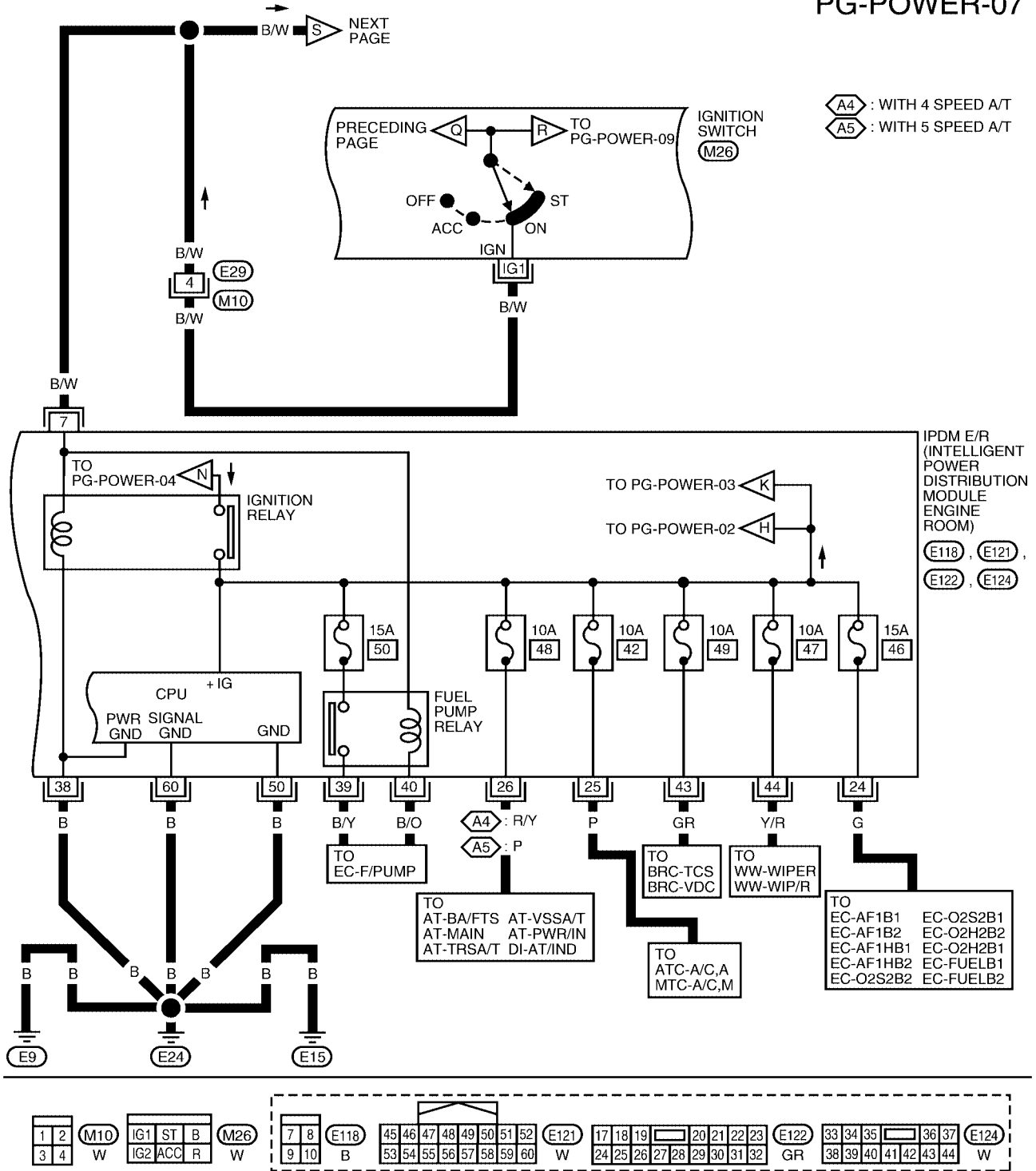

POWER SUPPLY ROUTING CIRCUIT

PG-POWER-08

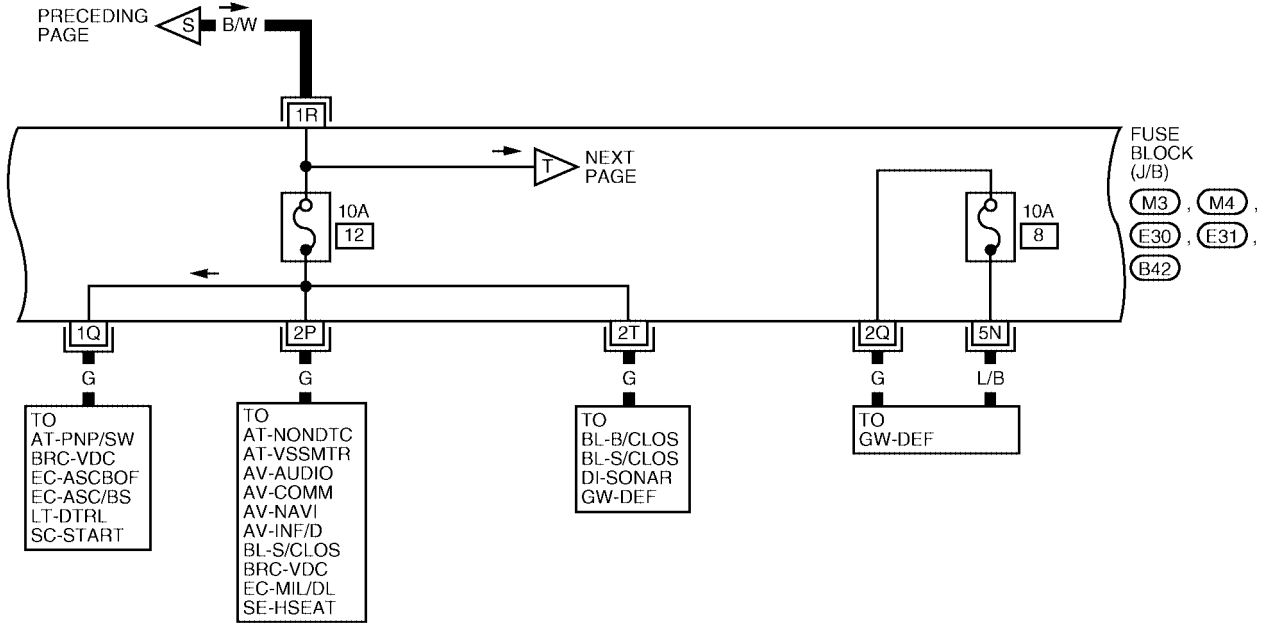

A
B
C
D
E
F
G
H
I
J
L
M

PG

REFER TO THE FOLLOWING.

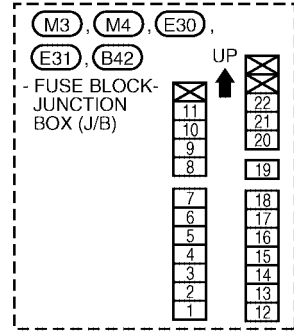

WKWA1711E

POWER SUPPLY ROUTING CIRCUIT

PG-POWER-09

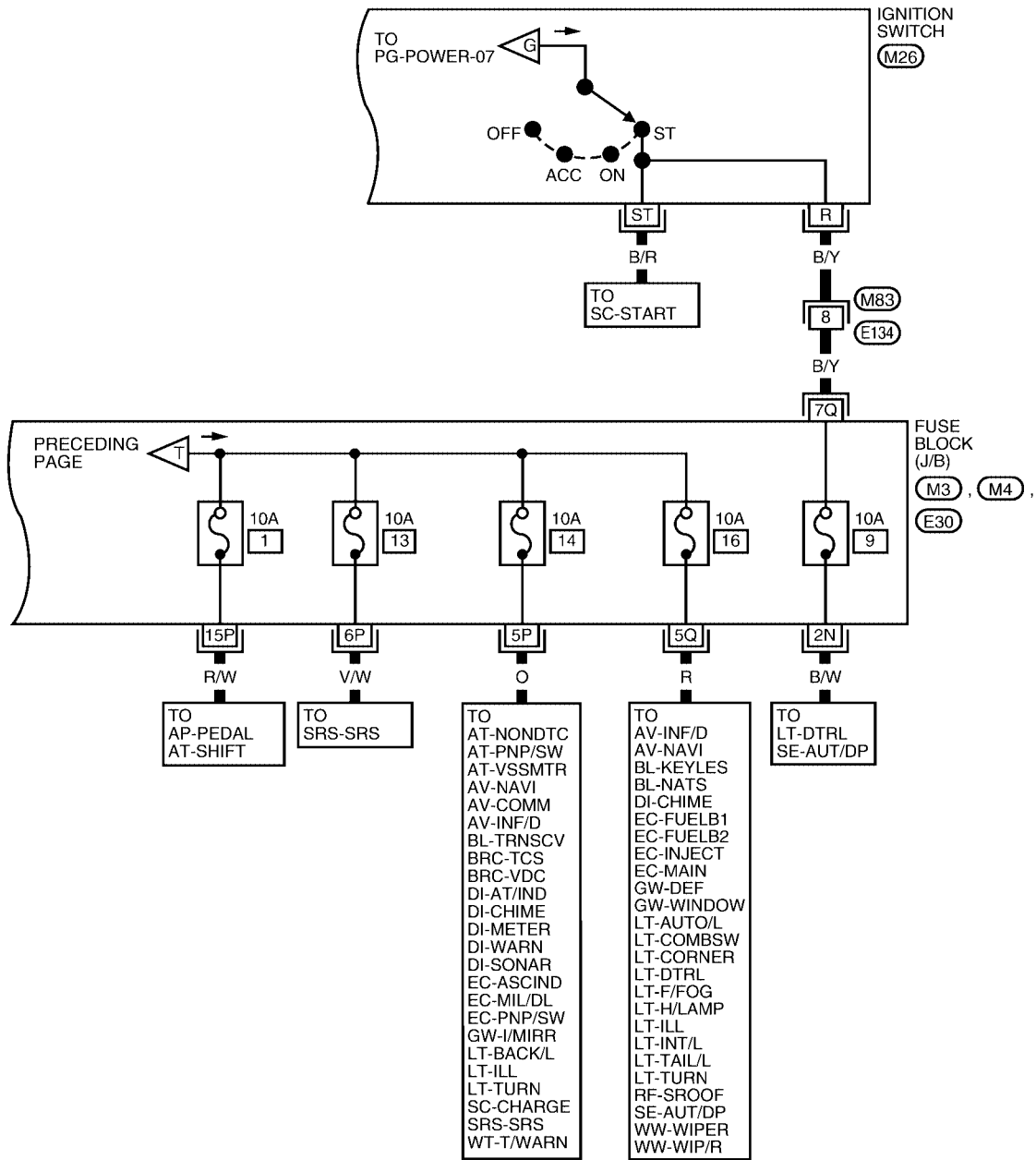

IG1	ST	B	(M26)
IG2	ACC	R	W

1	2	3	4	5	(M83)		
6	7	8	9	10	11	12	W

REFER TO THE FOLLOWING.

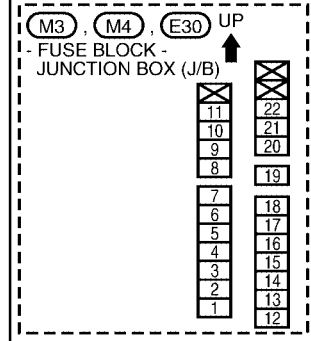

WKWA3994E

IPDM E/R (INTELLIGENT POWER DISTRIBUTION MODULE ENGINE ROOM)

IPDM E/R (INTELLIGENT POWER DISTRIBUTION MODULE ENGINE ROOM)

PF:284B7

System Description

EKS0064D

- IPDM E/R (Intelligent Power Distribution Module Engine Room) integrates the relay box and fuse block which were originally placed in engine compartment. It controls integrated relays via IPDM E/R control circuits.
- IPDM E/R-integrated control circuits perform ON-OFF operation of relays, CAN communication control, oil pressure switch signal reception, etc.
- It controls operation of each electrical component via ECM, BCM and CAN communication lines.

CAUTION:

None of the IPDM E/R integrated relays can be removed.

SYSTEMS CONTROLLED BY IPDM E/R

1. Lamp control
Using CAN communication lines, it receives signals from the BCM and controls the following lamps:
 - Headlamps (Hi, Lo)
 - Parking lamps
 - Tail and license lamps
 - Cornering lamps
 - Front fog lamps
2. Wiper control
Using CAN communication lines, it receives signals from the BCM and controls the front wipers.
3. Rear window defogger relay control
Using CAN communication lines, it receives signals from the BCM and controls the rear window defogger relay.
4. A/C compressor control
Using CAN communication lines, it receives signals from the ECM and controls the A/C compressor (magnetic clutch).
5. Starter control
Using CAN communication lines, it receives signals from the BCM and controls the starter relay.
6. Cooling fan control
Using CAN communication lines, it receives signals from the ECM and controls the cooling fan relays.
7. Horn control
Using CAN communication lines, it receives signals from the BCM and controls the horn relay.

CAN COMMUNICATION LINE CONTROL

With CAN communication, by connecting each control unit using two communication lines (CAN L-line, CAN H-line), it is possible to transmit a maximum amount of information with minimum wiring. Each control unit can transmit and receive data, and reads necessary information only.

1. Fail-safe control
 - When CAN communication with other control units is impossible, IPDM E/R performs fail-safe control. After CAN communication returns to normal operation, it also returns to normal control.
 - Operation of control parts by IPDM E/R during fail-safe mode is as follows:

Controlled system	Fail-safe mode
Headlamp	<ul style="list-style-type: none">● With the ignition switch ON, the headlamp (low) is ON.● With the ignition switch OFF, the headlamp (low) is OFF.
Tail and parking lamps	<ul style="list-style-type: none">● With the ignition switch ON, the tail and parking lamps are ON.● With the ignition switch OFF, the tail and parking lamps are OFF.
Cooling fan	<ul style="list-style-type: none">● With the ignition switch ON, the cooling fan HI operates.● With the ignition switch OFF, the cooling fan stops.
Front wiper	Until the ignition switch is turned off, the front wiper LO and HI remains in the same status it was in just before fail-safe control was initiated.
Rear window defogger	Rear window defogger relay OFF

IPDM E/R (INTELLIGENT POWER DISTRIBUTION MODULE ENGINE ROOM)

Controlled system	Fail-safe mode
A/C compressor	A/C compressor OFF
Front fog lamps	Front fog lamp relay OFF

IPDM E/R (INTELLIGENT POWER DISTRIBUTION MODULE ENGINE ROOM)

IPDM E/R STATUS CONTROL

In order to save power, IPDM E/R switches status by itself based on each operating condition.

1. CAN communication status
 - CAN communication is normally performed with other control units.
 - Individual unit control by IPDM E/R is normally performed.
 - When sleep request signal is received from BCM, mode is switched to sleep waiting status.
2. Sleep waiting status
 - Process to stop CAN communication is activated.
 - All systems controlled by IPDM E/R are stopped. When 1 second has elapsed after CAN communication with other control units is stopped, mode switches to sleep status.
3. Sleep status
 - IPDM E/R operates in low current-consumption mode.
 - CAN communication is stopped.
 - When a change in CAN communication signal is detected, mode switches to CAN communication status.
 - When a change in ignition switch signal is detected, mode switches to CAN communication status.

CAN Communication System Description

EKS0061C

Refer to [LAN-5, "CAN COMMUNICATION"](#) .

Function of Detecting Ignition Relay Malfunction

EKS0064E

- When the integrated ignition relay is stuck in a "closed contact" position and cannot be turned OFF, IPDM E/R turns ON tail and parking lamps for 10 minutes to indicate IPDM E/R malfunction.
- When the state of the integrated ignition relay does not agree with the state of the ignition switch signal received via CAN communication, the IPDM E/R activates the tail lamp relay.

Ignition switch signal	Ignition relay status	Tail lamp relay
ON	ON	—
OFF	OFF	—
ON	OFF	—
OFF	ON	ON (10 minutes)

NOTE:

When the ignition switch is turned ON, the tail lamps are OFF.

IPDM E/R (INTELLIGENT POWER DISTRIBUTION MODULE ENGINE ROOM)

EKS0064F

CONSULT-II Function (IPDM E/R)

CONSULT-II can display each diagnostic item using the diagnostic test modes shown following.

IPDM E/R diagnostic Mode	Description
SELF-DIAG RESULTS	Displays IPDM E/R self-diagnosis results.
DATA MONITOR	Displays IPDM E/R input/output data in real time.
CAN DIAG SUPPORT MNTR	The result of transmit/receive diagnosis of CAN communication can be read.
ACTIVE TEST	Operation of electrical loads can be checked by sending drive signal to them.

CONSULT-II BASIC OPERATION

CAUTION:

If CONSULT-II is used with no connection of CONSULT-II CONVERTER, malfunctions might be detected in self-diagnosis depending on control unit which carries out CAN communication.

1. With the ignition switch OFF, connect CONSULT-II and CONSULT-II CONVERTER to the data link connector, then turn ignition switch ON.

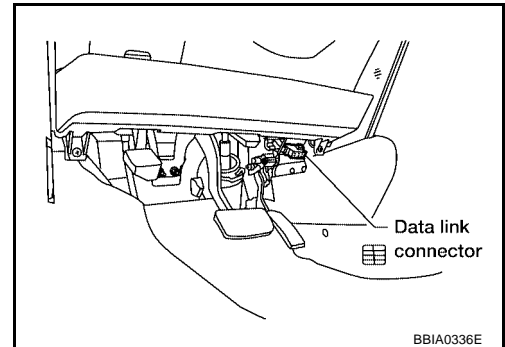

2. Touch "START (NISSAN BASED VHCL)".

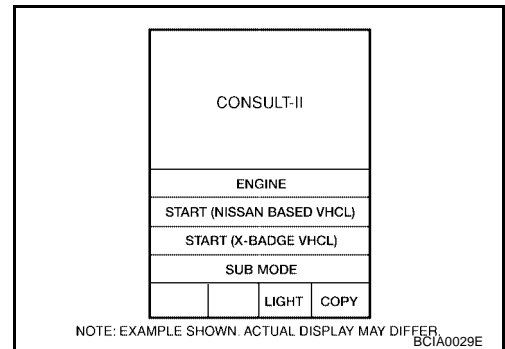

3. Touch "IPDM E/R" on "SELECT SYSTEM" screen. If "IPDM E/R" is not displayed go to [GI-37, "CONSULT-II Data Link Connector \(DLC\) Circuit"](#).

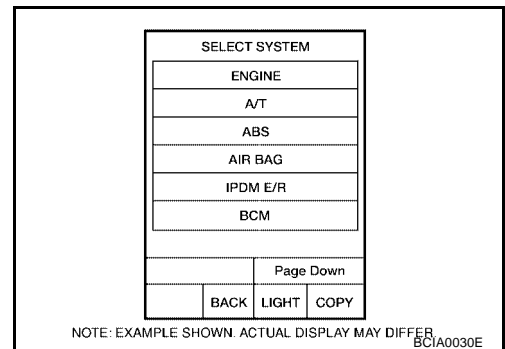

IPDM E/R (INTELLIGENT POWER DISTRIBUTION MODULE ENGINE ROOM)

- Select the desired part to be diagnosed on the "SELECT DIAG MODE" screen.

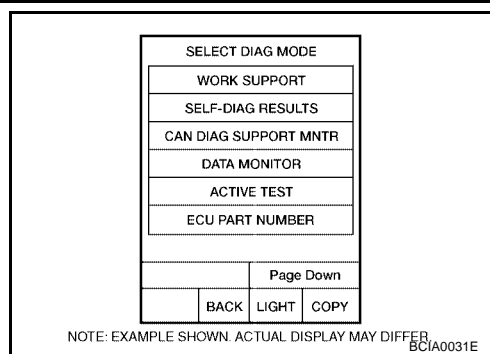

SELF-DIAGNOSTIC RESULTS

Operation Procedure

- Touch "SELF-DIAG RESULTS" on "SELECT DIAG MODE" screen.
- Self-diagnosis results are displayed.

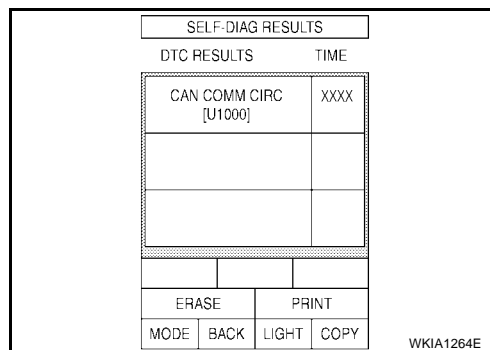

Display Item List

Display items	CONSULT-II display code	Malfunction detection	TIME		Possible causes
			CRNT	PAST	
NO DTC IS DETECTED. FURTHER TESTING MAY BE REQUIRED.	—	—	—	—	—
CAN COMM CIRC	U1000	<ul style="list-style-type: none"> If CAN communication reception/transmission data has a malfunction, or if any of the control units fail, data reception/transmission cannot be confirmed. When the data in CAN communication is not received before the specified time. 	X	X	Any of items listed below have errors: <ul style="list-style-type: none"> TRANSMIT DIAG ECM BCM/SEC

NOTE:

The details for display of the period are as follows:

- CRNT: Error currently detected with IPDM E/R.
- PAST: Error detected in the past and placed in IPDM E/R memory.

DATA MONITOR

Operation Procedure

- Touch "DATA MONITOR" on "SELECT DIAG MODE" screen.
- Touch "ALL SIGNALS", "MAIN SIGNALS" or "SELECTION FROM MENU" on the "DATA MONITOR" screen.

ALL SIGNALS	All signals will be monitored.
MAIN SIGNALS	Monitors the predetermined item(s).
SELECTION FROM MENU	Selects and monitors individual signal(s).

- Touch "START".
- When "SELECTION FROM MENU" is selected, touch items to be monitored. When "ALL SIGNALS" is selected, all the items will be monitored. When "MAIN SIGNALS" is selected, predetermined items are monitored.

IPDM E/R (INTELLIGENT POWER DISTRIBUTION MODULE ENGINE ROOM)

5. Touch "RECORD" while monitoring to record the status of the item being monitored. To stop recording, touch "STOP".

IPDM E/R (INTELLIGENT POWER DISTRIBUTION MODULE ENGINE ROOM)

All Signals, Main Signals, Selection From Menu

Item name	CONSULT-II screen display	Display or unit	Monitor item selection			Description
			ALL SIGNALS	MAIN SIGNALS	SELECTION FROM MENU	
Motor fan request	MOTOR FAN REQ	1/2/3/4	X	X	X	Signal status input from ECM
Compressor request	AC COMP REQ	ON/OFF	X	X	X	Signal status input from ECM
Parking, license, and tail lamp request	TAIL & CLR REQ	ON/OFF	X	X	X	Signal status input from BCM
Headlamp low beam request	HL LO REQ	ON/OFF	X	X	X	Signal status input from BCM
Headlamp high beam request	HL HI REQ	ON/OFF	X	X	X	Signal status input from BCM
Front fog request	FR FOG REQ	ON/OFF	X	X	X	Signal status input from BCM
FR wiper request	FR WIP REQ	STOP/1LO/LO/HI	X	X	X	Signal status input from BCM
Wiper auto stop	WIP AUTO STOP	ACT P/STOP P	X	X	X	Output status of IPDM E/R
Wiper protection	WIP PROT	OFF/LS/HS/Block	X	X	X	Control status of IPDM E/R
Starter request	ST RLY REQ	ON/OFF	X		X	Status of input signal ^{NOTE}
Ignition relay status	IGN RLY	ON/OFF	X	X	X	Ignition relay status monitored with IPDM E/R
Rear defogger request	RR DEF REQ	ON/OFF	X	X	X	Signal status input from BCM
Oil pressure switch	OIL P SW	OPEN/CLOSE	X		X	Signal status input from IPDM E/R
Hood switch	HOOD SW (*1)	OFF	X			Signal status input from IPDM E/R
Theft warning horn request	THFT HRN REQ	ON/OFF	X		X	Signal status input from BCM
Horn chirp	HORN CHIRP	ON/OFF	X		X	Output status of IPDM E/R
Cornering lamp request	CRNRNG LMP REQ	OFF/LEFT/RIGHT	X		X	Signal status input from BCM

NOTE:

- Perform monitoring of IPDM E/R data with the ignition switch ON. When the ignition switch is in ACC position, display may not be correct.
- (*1) This item is displayed, but does not function.

ACTIVE TEST

Operation Procedure

1. Touch "ACTIVE TEST" on "SELECT DIAG-MODE" screen.
2. Touch item to be tested, and check operation.
3. Touch "START".
4. Touch "STOP" while testing to stop the operation.

Test name	CONSULT-II screen display	Description
Tail lamp output	TAIL LAMP	With a certain ON-OFF operation, the tail lamp relay can be operated.
Rear defogger output	REAR DEFOGGER	With a certain ON-OFF operation, the rear defogger relay can be operated.
Front wiper (HI, LO) output	FRONT WIPER	With a certain operation (OFF, HI ON, LO ON), the front wiper relay (Lo, Hi) can be operated.

IPDM E/R (INTELLIGENT POWER DISTRIBUTION MODULE ENGINE ROOM)

Test name	CONSULT-II screen display	Description
Cooling fan output	MOTOR FAN	With a certain operation (1, 2, 3, 4), the cooling fan can be operated.
Lamp (HI, LO, FOG) output	LAMPS	With a certain operation (OFF, HI ON, LO ON, FOG ON), the lamp relay (Lo, Hi, Fog) can be operated.
Cornering lamp output	CORNERING LAMP	—
Horn output	HORN	With a certain ON-OFF operation, the horn relay can be operated.

Auto Active Test DESCRIPTION

EKS0064G

- In auto active test mode, operation inspection can be performed when IPDM E/R sends a drive signal to the following systems:
 - Rear window defogger
 - Front wipers
 - Tail, license and parking lamps
 - Cornering lamps
 - Front fog lamps
 - Headlamps (Hi, Lo)
 - A/C compressor (magnetic clutch)
 - Cooling fan

OPERATION PROCEDURE

1. Close hood and front door RH, and lift wiper arms away from windshield (to prevent glass damage by wiper operation).

NOTE:

When auto active test is performed with hood opened, sprinkle water on windshield beforehand.

2. Turn ignition switch OFF.
3. Turn ignition switch ON and, within 20 seconds, press front door switch LH 10 times. Then turn ignition switch OFF.
4. Turn ignition switch ON within 10 seconds after ignition switch OFF.
5. When auto active test mode is actuated, horn chirps once.
6. After a series of operations is repeated three times, auto active test is completed.

NOTE:

When auto active test mode has to be cancelled halfway, turn ignition switch OFF.

CAUTION:

Be sure to perform **BL-43, "Door Switch Check (With Automatic Back Door System)"** or **BL-41, "Door Switch Check (Without Automatic Back Door System)"** when the auto active test cannot be performed.

IPDM E/R (INTELLIGENT POWER DISTRIBUTION MODULE ENGINE ROOM)

INSPECTION IN AUTO ACTIVE TEST MODE

- When auto active test mode is actuated, the following nine steps are repeated three times.

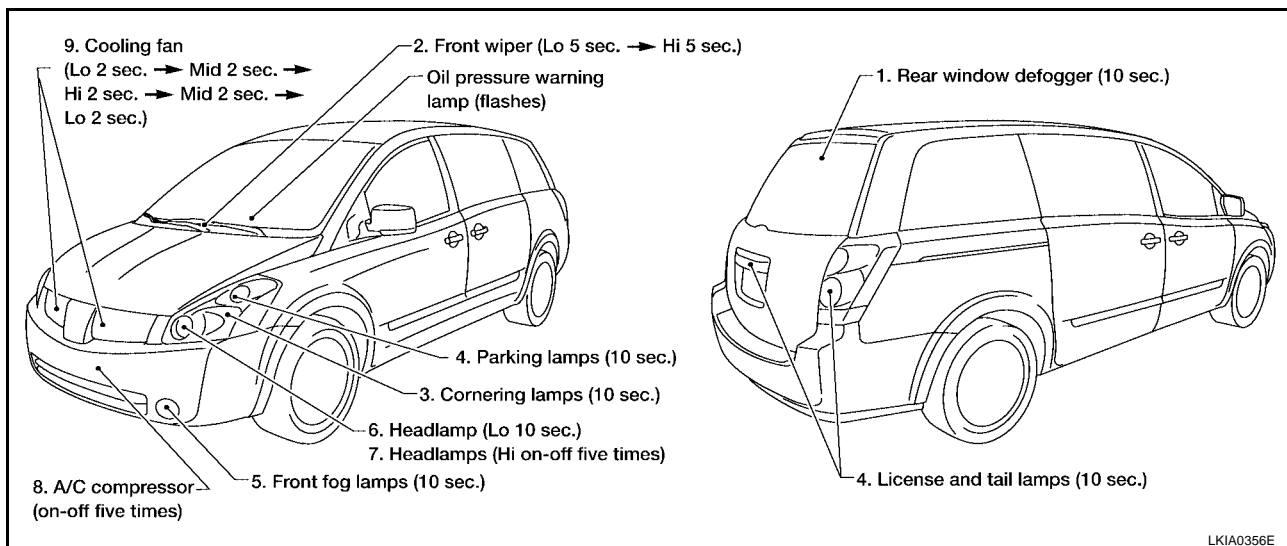

Concept of Auto Active Test

- IPDM E/R actuates auto active test mode when it receives door switch signal from BCM via CAN communication line. Therefore, when auto active test mode is activated successfully, CAN communication between IPDM E/R and BCM is normal.
- If any of the systems controlled by IPDM E/R cannot be operated, possible cause can be easily diagnosed using auto active test.

Diagnosis chart in auto active test mode

Symptom	Inspection contents	Possible cause	
Rear window defogger does not operate.	Perform auto active test. Does rear window defogger operate?	YES	<ul style="list-style-type: none"> ● BCM signal input circuit
		NO	<ul style="list-style-type: none"> ● Rear window defogger relay ● Open circuit of rear window defogger ● IPDM E/R malfunction ● Harness or connector malfunction between IPDM E/R and rear window defogger
Any of front wipers, tail and parking lamps, front fog lamps, cornering lamps, and headlamps (Hi, Lo) do not operate.	Perform auto active test. Does system in question operate?	YES	<ul style="list-style-type: none"> ● BCM signal input system
		NO	<ul style="list-style-type: none"> ● Lamp/wiper motor malfunction ● Lamp/wiper motor ground circuit malfunction ● Harness/connector malfunction between IPDM E/R and system in question ● IPDM E/R (integrated relay) malfunction
A/C compressor does not operate.	Perform auto active test. Does magnetic clutch operate?	YES	<ul style="list-style-type: none"> ● BCM signal input circuit ● CAN communication signal between BCM and ECM. ● CAN communication signal between ECM and IPDM E/R
		NO	<ul style="list-style-type: none"> ● Magnetic clutch malfunction ● Harness/connector malfunction between IPDM E/R and magnetic clutch ● IPDM E/R (integrated relay) malfunction
Cooling fan does not operate.	Perform auto active test. Does cooling fan operate?	YES	<ul style="list-style-type: none"> ● ECM signal input circuit ● CAN communication signal between ECM and IPDM E/R
		NO	<ul style="list-style-type: none"> ● Cooling fan motor malfunction ● Harness/connector malfunction between IPDM E/R and cooling fan motor ● IPDM E/R (integrated relay) malfunction

IPDM E/R (INTELLIGENT POWER DISTRIBUTION MODULE ENGINE ROOM)

Symptom	Inspection contents		Possible cause
Oil pressure warning lamp does not operate.	Perform auto active test. Does oil pressure warning lamp blink?	YES	<ul style="list-style-type: none"> ● Harness/connector malfunction between IPDM E/R and oil pressure switch ● Oil pressure switch malfunction ● IPDM E/R
		NO	<ul style="list-style-type: none"> ● CAN communication signal between BCM and Combination Meter ● Combination meter

IPDM E/R (INTELLIGENT POWER DISTRIBUTION MODULE ENGINE ROOM)

EKS0064H

Schematic

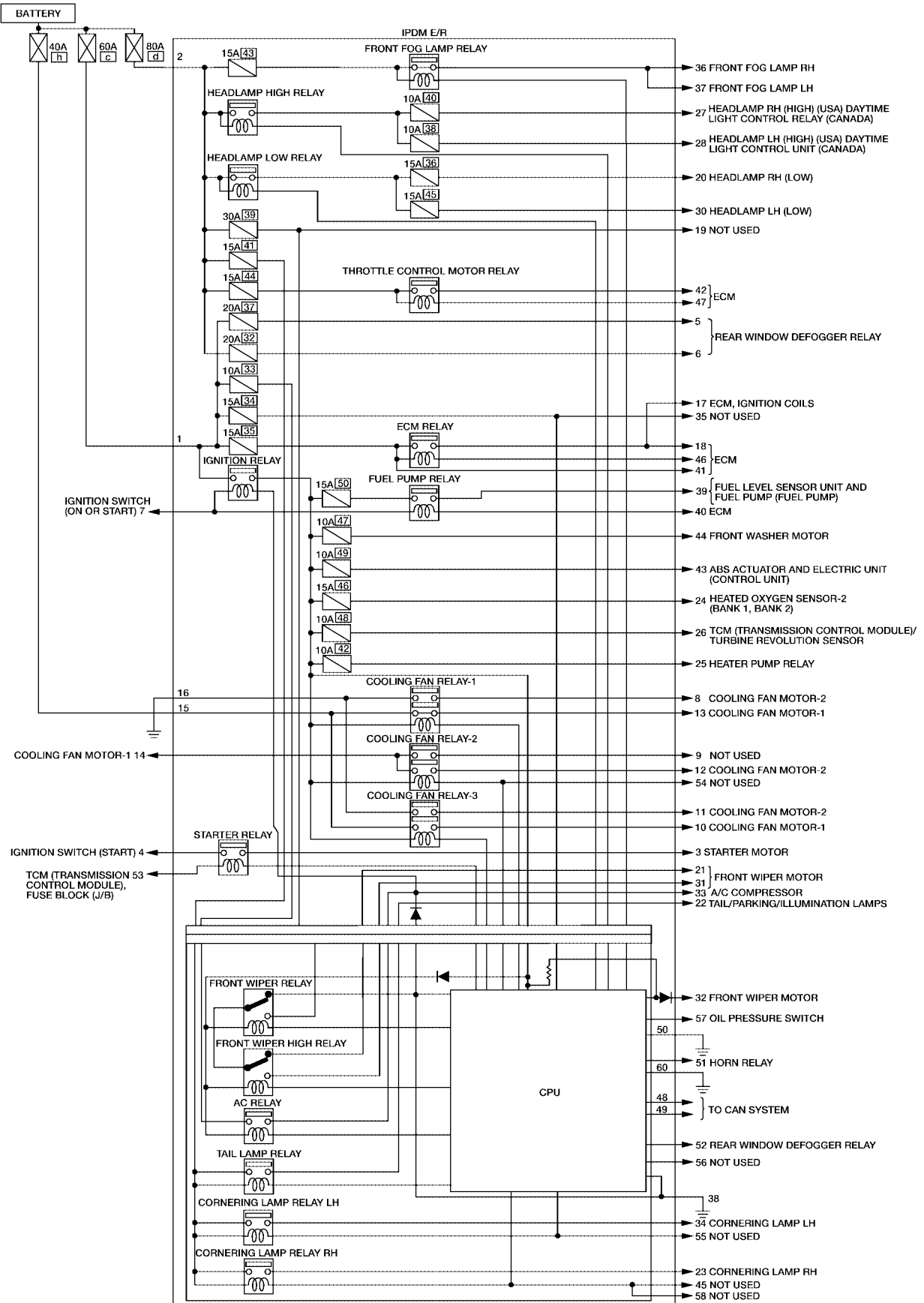

A
B
C
D
E
F
G
H
I
J
K
L
M

PG

WKWA3995E

IPDM E/R Terminal Arrangement

EKS0064I

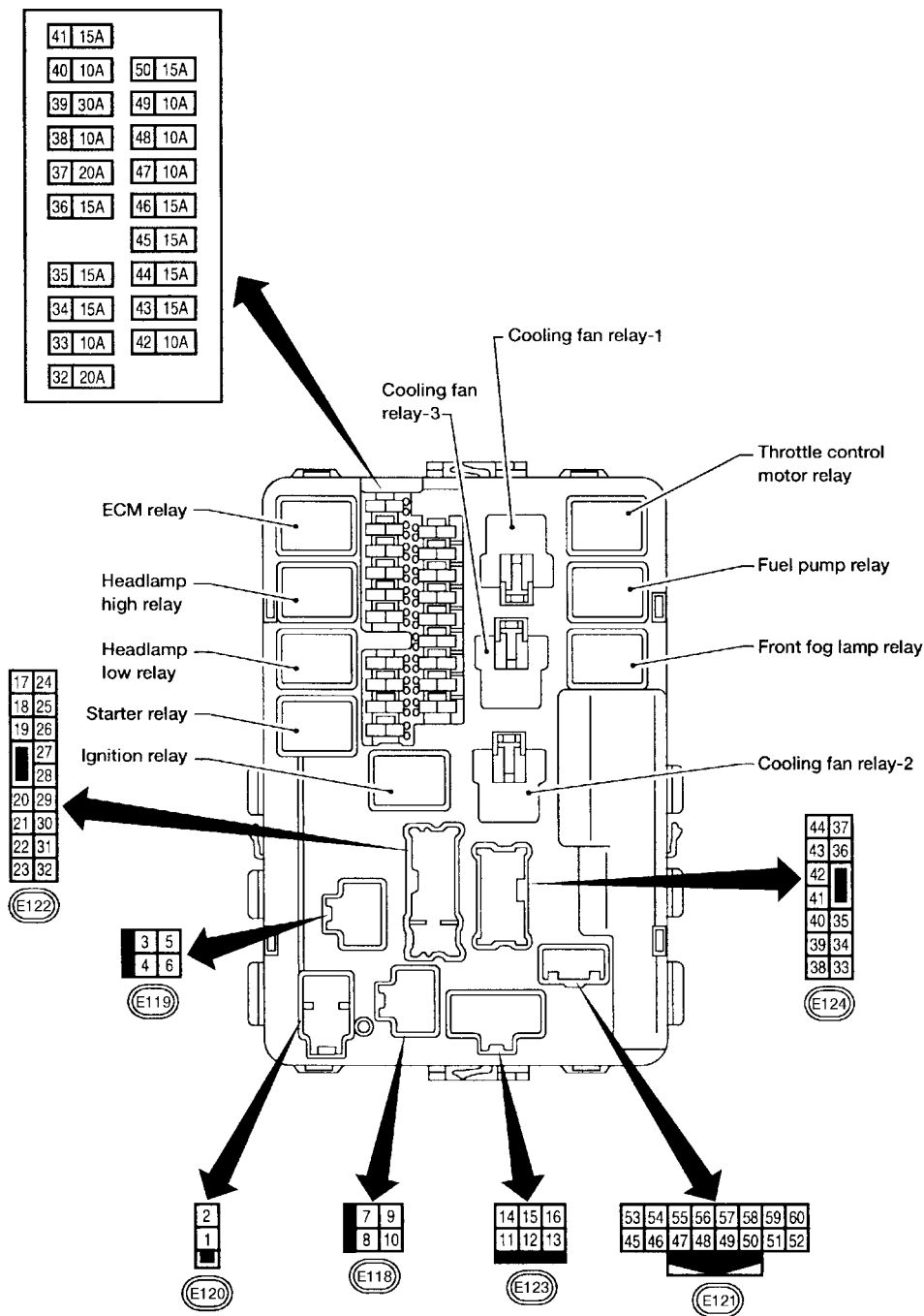

WKIA1203E

IPDM E/R (INTELLIGENT POWER DISTRIBUTION MODULE ENGINE ROOM)

IPDM E/R Power/Ground Circuit Inspection

EKS0064J

1. FUSE AND FUSIBLE LINK INSPECTION

Check that the following fusible links or IPDM E/R fuses are not blown.

Terminal No.	Signal name	Fuse, fusible link No.
1, 2,	Battery power	a, c, d

OK or NG

- OK >> GO TO 2.
- NG >> Replace fuse or fusible link.

2. POWER CIRCUIT INSPECTION

1. Turn ignition switch off.
2. Disconnect IPDM E/R harness connector E120.
3. Check voltage between IPDM E/R harness connector E120 terminals 1 (R), 2 (B/Y) and ground.

Battery voltage should exist.

OK or NG

- OK >> GO TO 3.
- NG >> Repair or replace IPDM E/R power circuit harness.

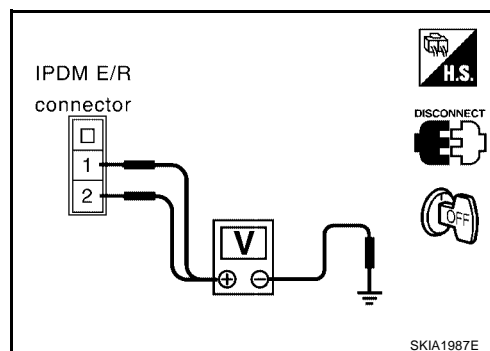

3. GROUND CIRCUIT INSPECTION

1. Disconnect IPDM E/R harness connectors E121 and E124.
2. Check continuity between IPDM E/R harness connector (A) E121 terminal 60 (B), (B) E124 terminal 38 (B) and ground.

Continuity should exist.

OK or NG

- OK >> Inspection End.
- NG >> Repair or replace IPDM E/R ground circuit harness.

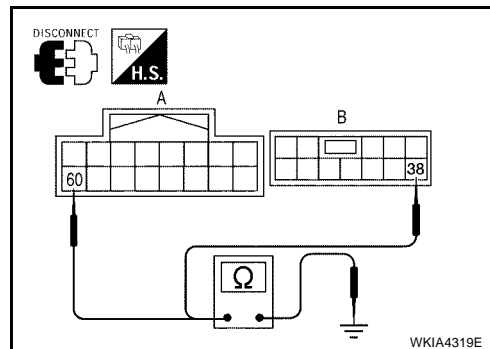

IPDM E/R (INTELLIGENT POWER DISTRIBUTION MODULE ENGINE ROOM)

Inspection with CONSULT-II (Self-Diagnosis)

EKS0064K

CAUTION:

If a CONSULT-II is used with no connection of CONSULT-II CONVERTER, malfunctions might be detected in self-diagnosis depending on which control unit(s) carry out CAN communication.

1. SELF-DIAGNOSIS RESULT CHECK

1. Connect CONSULT-II and select "IPDM E/R" on the Diagnosis System Selection screen.
2. Select "SELF-DIAG RESULTS" on the diagnosis mode selection screen.
3. Check display content in self-diagnosis results.

CONSULT-II Display	CONSULT-II display code	TIME		Details of diagnosis result
		CRNT	PAST	
NO DTC IS DETECTED. FURTHER TESTING MAY BE REQUIRED.	—	—	—	No malfunction
CAN COMM CIRC	U1000	X	X	Any of items listed below have errors: <ul style="list-style-type: none">● TRANSMIT DIAG● ECM● BCM/SEC

NOTE:

The Details for Display for the Period are as follows:

- CRNT: Error currently detected by IPDM E/R.
- PAST: Error detected in the past and stored in IPDM E/R memory.

Contents displayed

NO DTC DETECTED. FURTHER TESTING MAY BE REQUIRED.>>INSPECTION END.

CAN COMM CIRC>>Print out the self-diagnosis result and refer to [LAN-5, "CAN COMMUNICATION"](#) .

IPDM E/R (INTELLIGENT POWER DISTRIBUTION MODULE ENGINE ROOM)

EKS0064L

Removal and Installation of IPDM E/R

REMOVAL

1. Disconnect negative battery cable.
2. Remove coolant reservoir fasteners.
3. Move coolant reservoir aside.
4. Remove IPDM E/R upper cover.

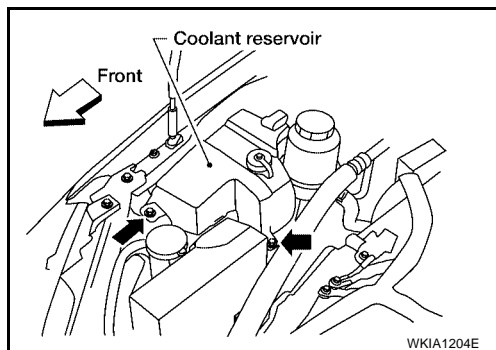

5. Remove IPDM E/R harness cover.

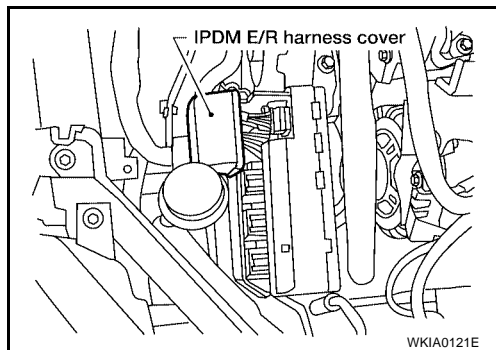

6. Release 2 clips and pull IPDM E/R up from case.
7. Disconnect IPDM E/R connectors and remove the IPDM E/R.

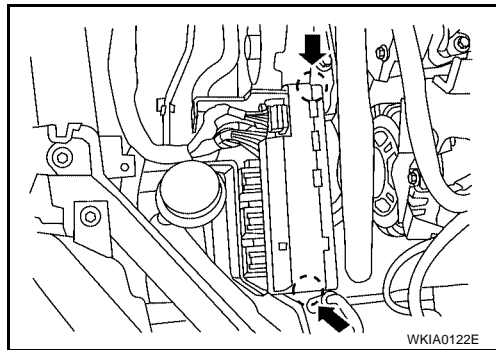

INSTALLATION

Installation is in the reverse order of removal.

A
B
C
D
E
F
G
H
I
J
PG
L
M

GROUND CIRCUIT

PFP:24080

EKS0064M

GROUND CIRCUIT

Ground Distribution MAIN HARNESS

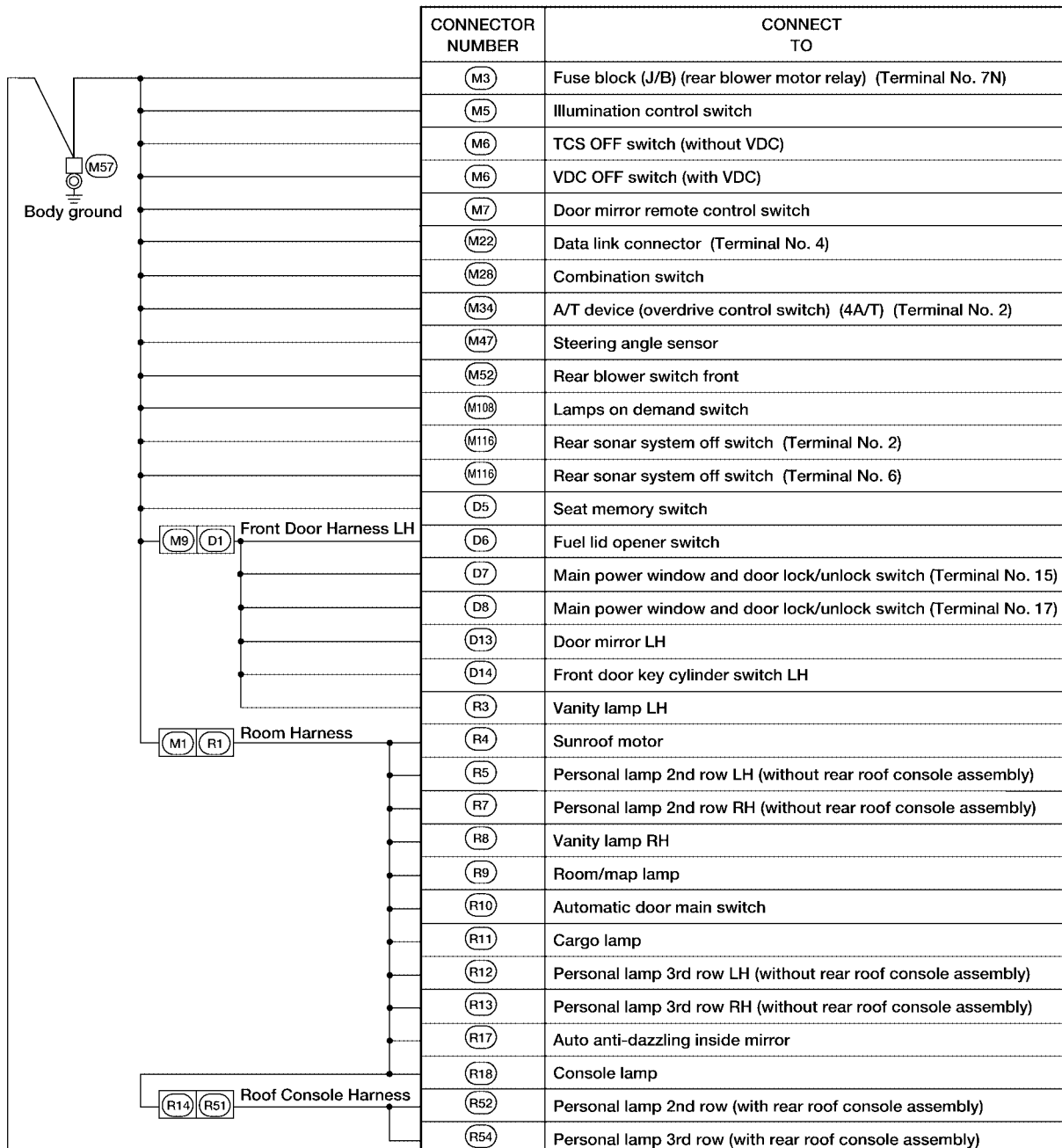
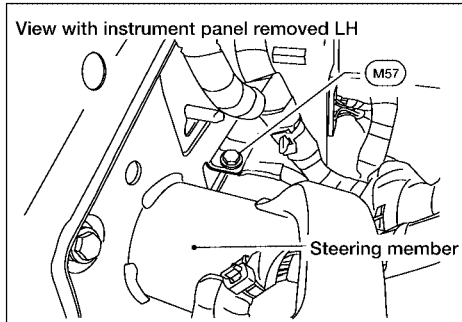

Next page

WKIA3426E

GROUND CIRCUIT

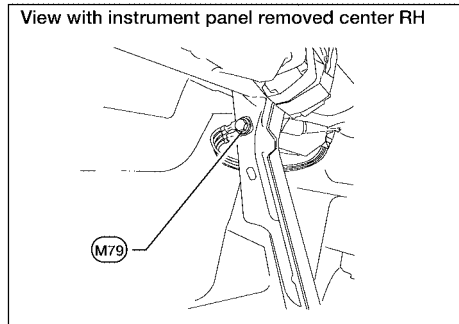
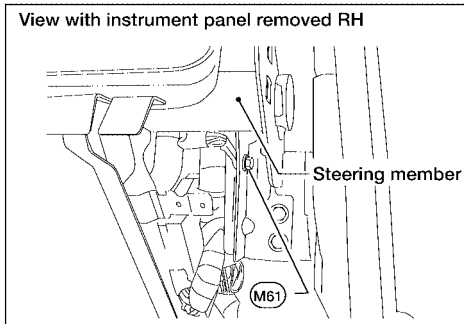

Preceding page

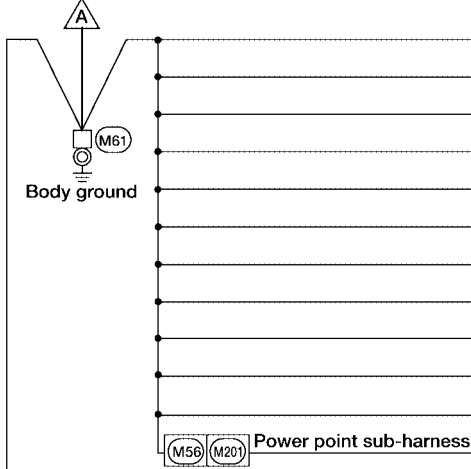

CONNECTOR NUMBER	CONNECT TO
M14	Pedal adjusting control unit (Terminal No. 1)
M19	BCM (body control module) (Terminal No. 52)
M21	NATS antenna amplifier
M22	Data link connector (Terminal No. 5)
M34	A/T device (shift lock and detent switch) (Terminal No. 6)
M35	Air bag diagnosis sensor unit (Terminal No. 2)
M42	Automatic drive positioner control unit (Terminal No. 40)
M49	Front air control (Terminal No. 1)
M55	Hazard switch
M59	Glove box lamp
M122	Variable blower control (Terminal No. 4)
M202	Front power socket-1 (console)

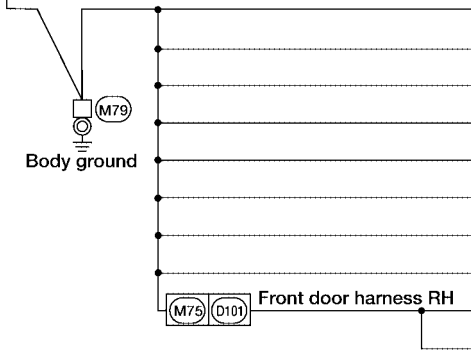

CONNECTOR NUMBER	CONNECT TO
M23	Combination meter (Terminal No. 32)
M33	Front power socket-2 (console side)
M42	Automatic drive positioner control unit (Terminal No. 48)
M93	Display unit (without NAVI) (Terminal No. 6)
M93	Display unit (with NAVI) (Terminal No. 1)
M94	Display control unit (with NAVI) (Terminal No. 3)
M98	AV switch
M113	BOSE® speaker amp.
D105	Front power window and door lock/unlock switch RH
D113	Door mirror RH

A
B
C
D
E
F
G
H
I
J
L
M

PG

WKIA4803E

GROUND CIRCUIT

ENGINE ROOM HARNESS

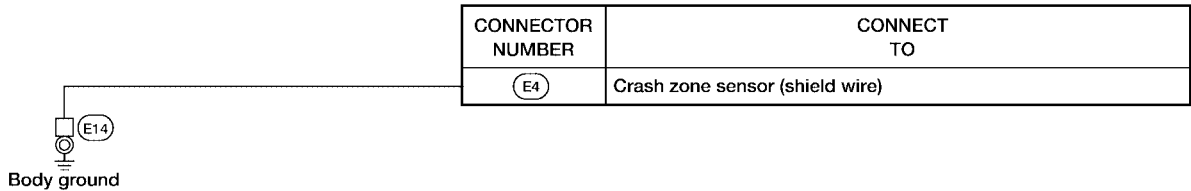
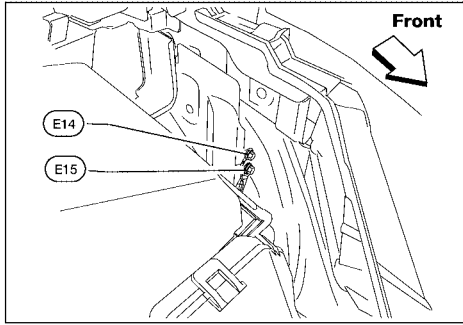

CONNECTOR NUMBER	CONNECT TO
(E4)	Crash zone sensor (shield wire)

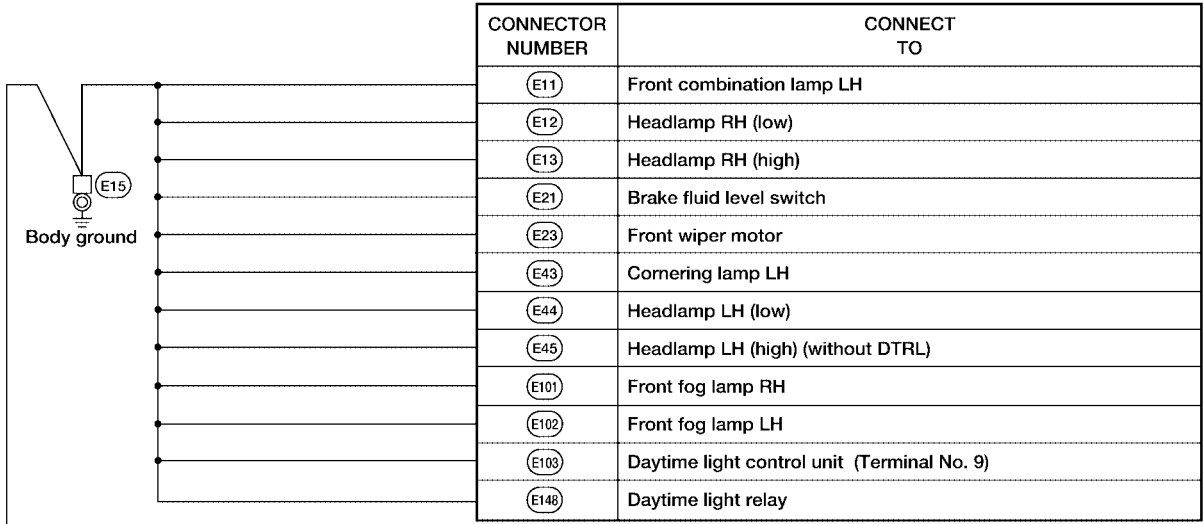

CONNECTOR NUMBER	CONNECT TO
(E11)	Front combination lamp LH
(E12)	Headlamp RH (low)
(E13)	Headlamp RH (high)
(E21)	Brake fluid level switch
(E23)	Front wiper motor
(E43)	Cornering lamp LH
(E44)	Headlamp LH (low)
(E45)	Headlamp LH (high) (without DTRL)
(E101)	Front fog lamp RH
(E102)	Front fog lamp LH
(E103)	Daytime light control unit (Terminal No. 9)
(E148)	Daytime light relay

B
Next page

GROUND CIRCUIT

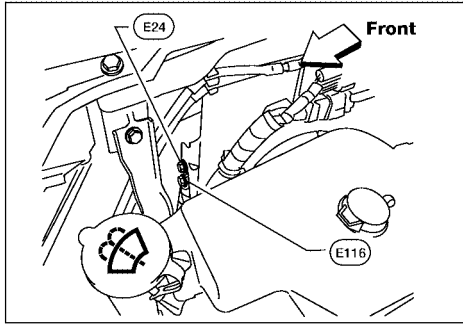

Preceding page

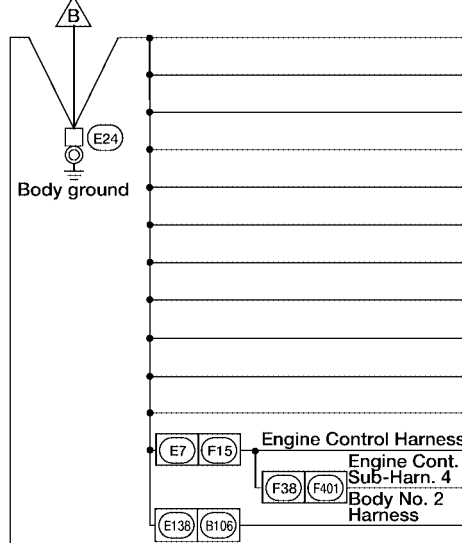

CONNECTOR NUMBER	CONNECT TO
(E106)	Washer fluid level switch
(E107)	Front combination lamp RH
(E113)	Cooling fan motor-1 (Terminal No. 3)
(E113)	Cooling fan motor-1 (Terminal No. 4)
(E121)	IPDM E/R (intelligent power dist module eng room) (Terminal No. 50)
(E121)	IPDM E/R (intelligent power dist module eng room) (Terminal No. 60)
(E123)	IPDM E/R (intelligent power dist module eng room) (Terminal No. 16)
(E124)	IPDM E/R (intelligent power dist module eng room) (Terminal No. 38)
(E127)	Heater pump
(E137)	Cornering lamp RH
(E142)	TCM (5 A/T) (Terminal No. 48)
(F37)	Turbine revolution sensor (5 A/T) (shield wire)
(F402)	Revolution sensor (5 A/T) (shield wire)
(B125)	Yaw rate/side/decel G-sensor (shield wire)

Next page

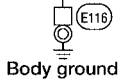

CONNECTOR NUMBER	CONNECT TO
(E112)	Generator

A
B
C
D
E
F
G
H
I
J
L
M

PG

WKIA4804E

GROUND CIRCUIT

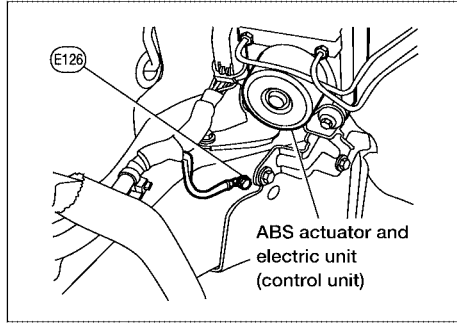
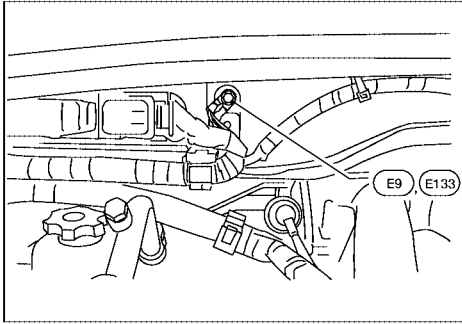

Preceding page

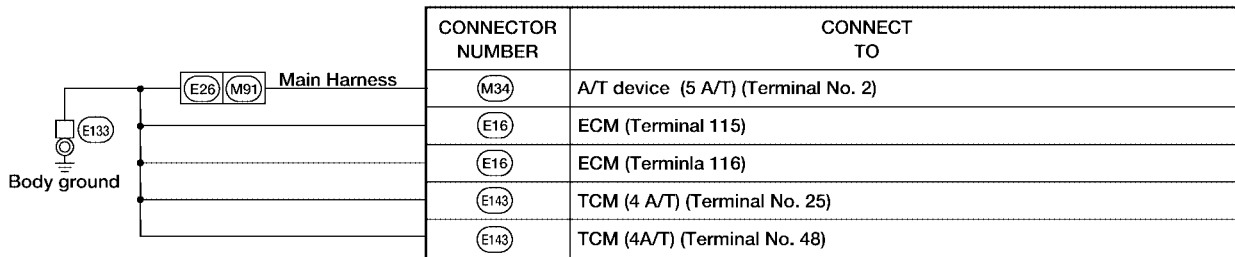
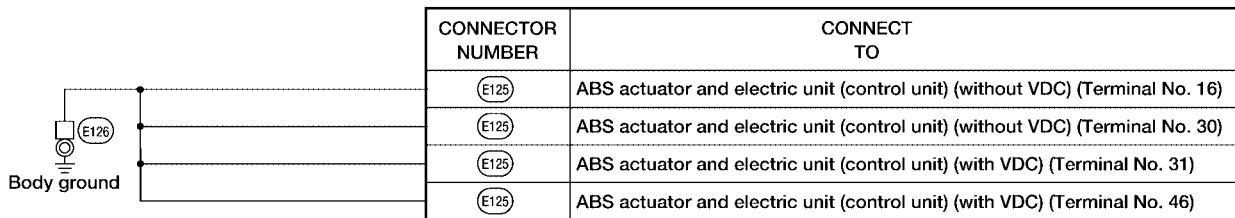
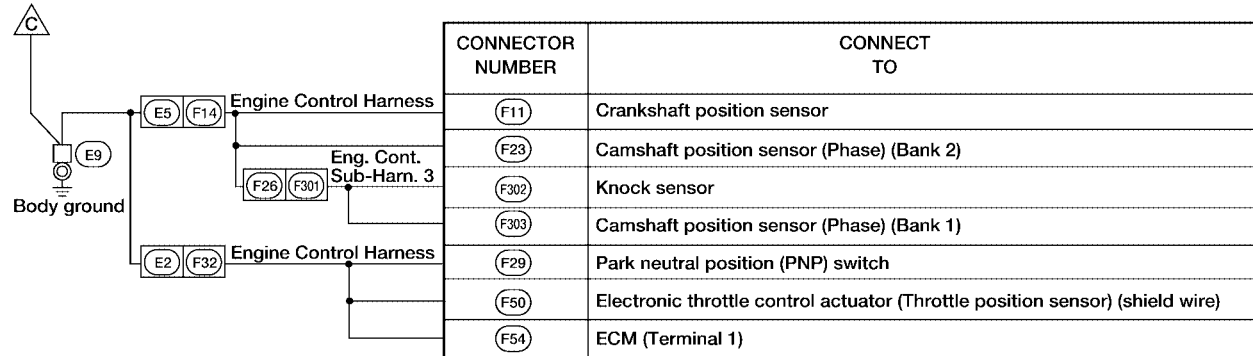

WKIA4805E

GROUND CIRCUIT

ENGINE CONTROL HARNESS

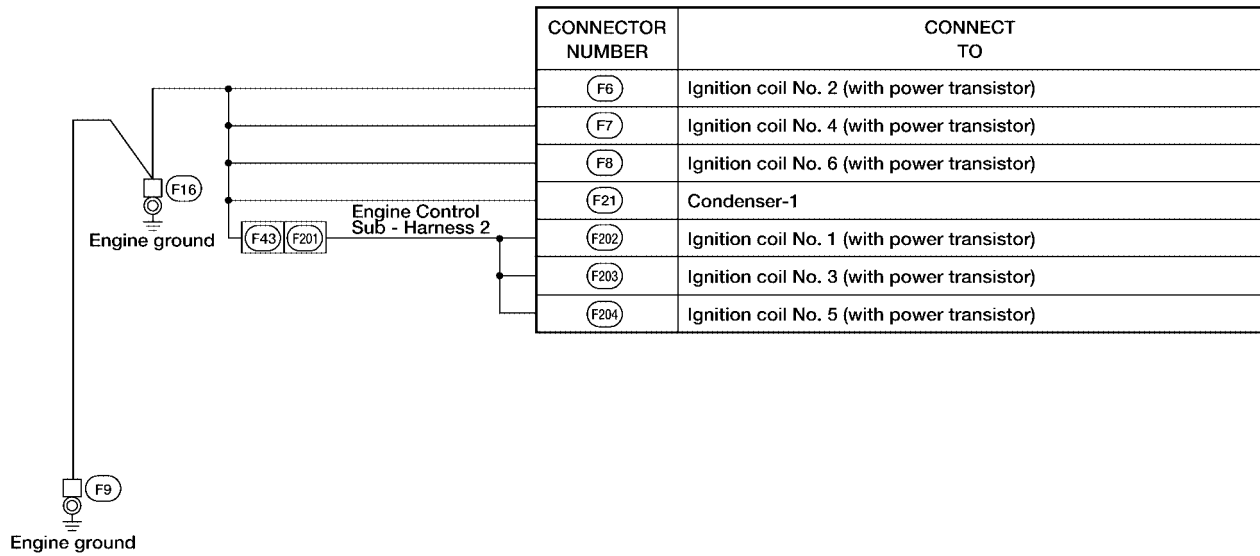
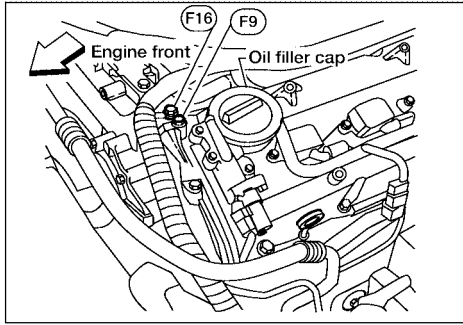

A
B
C
D
E
F
G
H
I
J
PG
L
M

GROUND CIRCUIT

BODY HARNESS

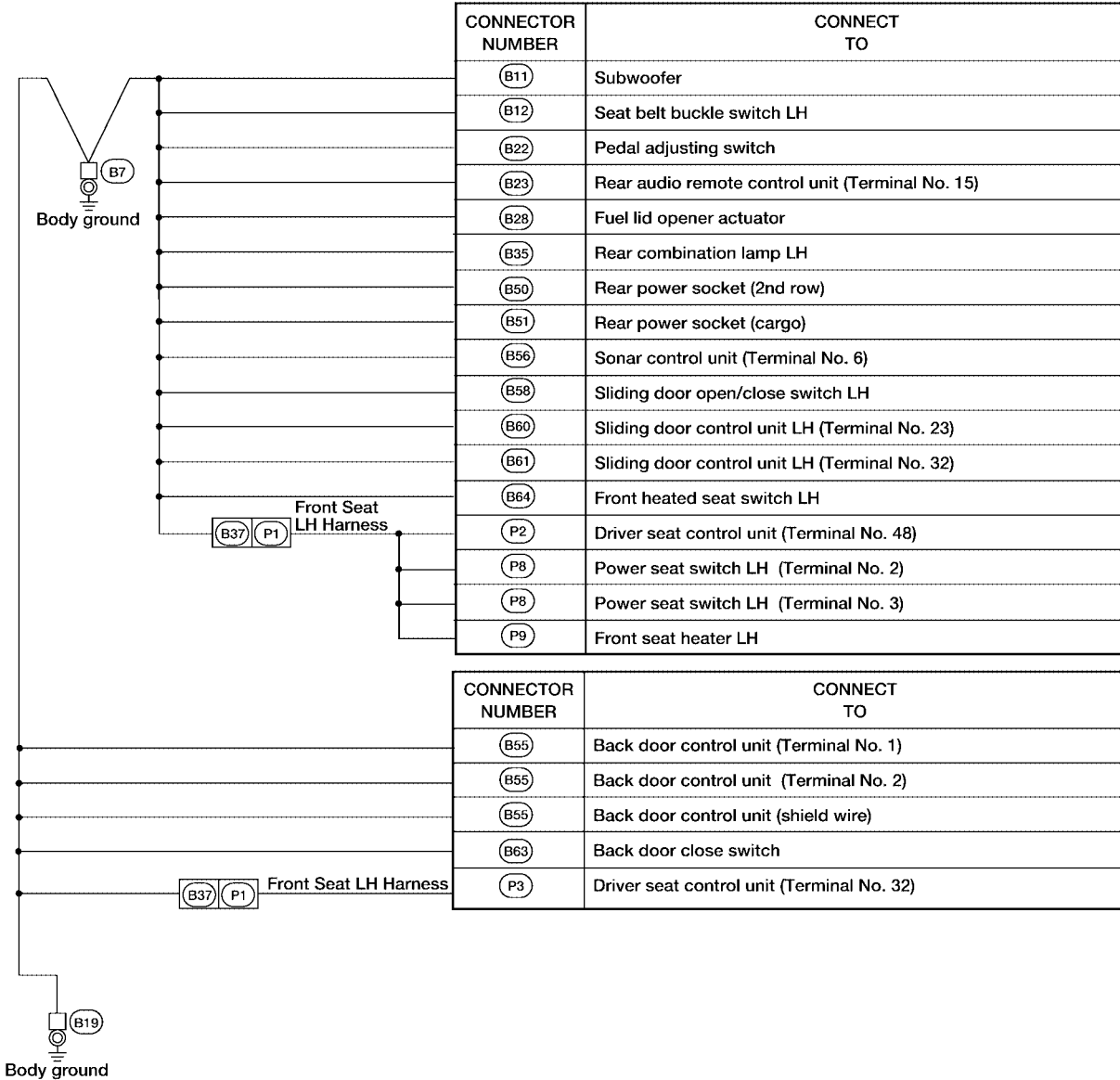
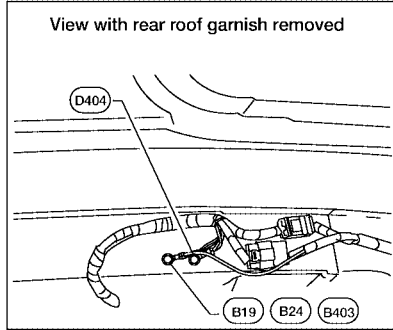
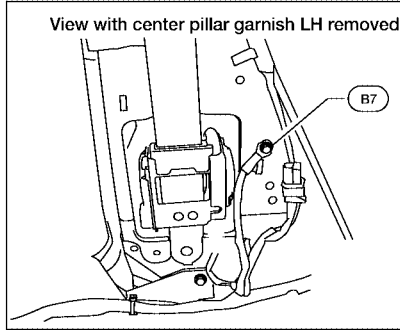

WKIA4806E

GROUND CIRCUIT

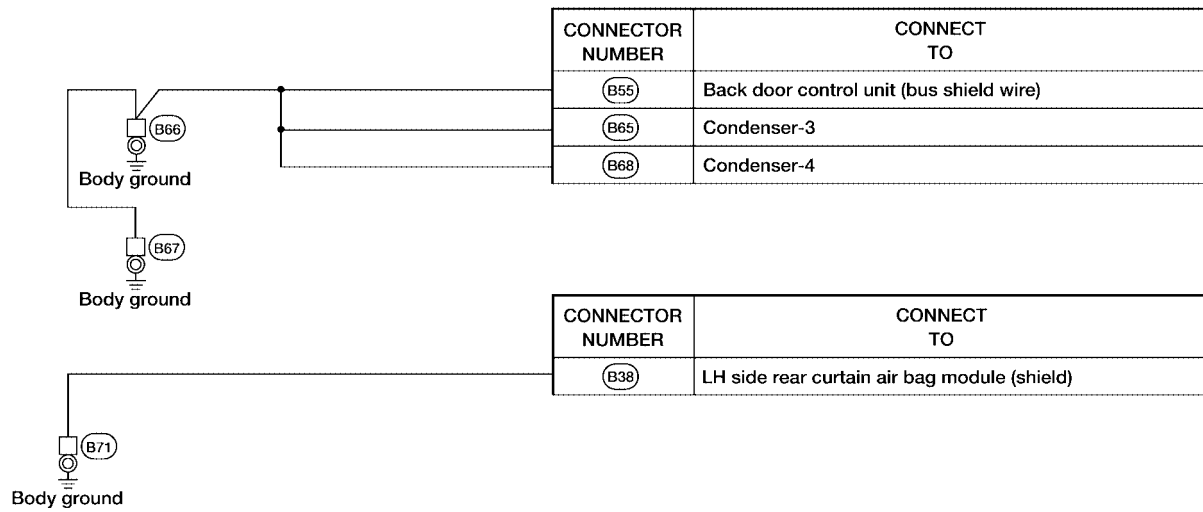
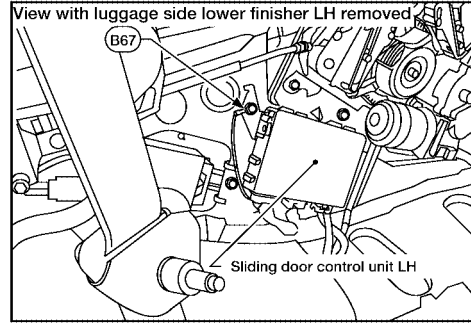
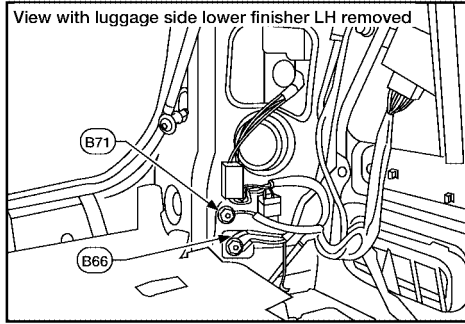

A
B
C
D
E
F
G
H
I
J
PG
L
M

WKIA4807E

GROUND CIRCUIT

BODY NO. 2 HARNESS

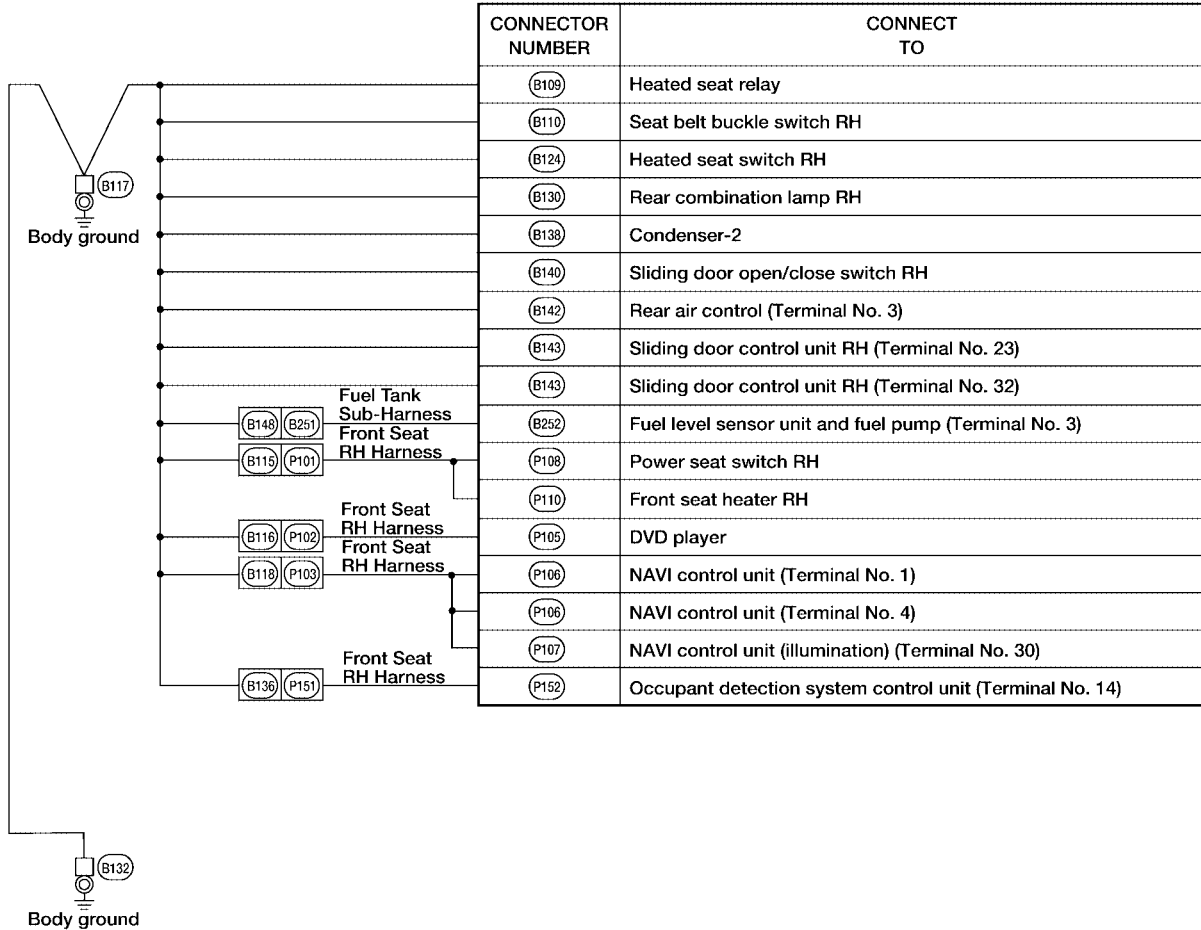
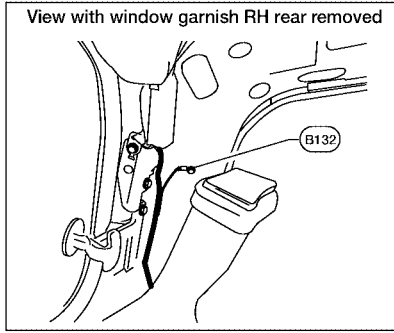
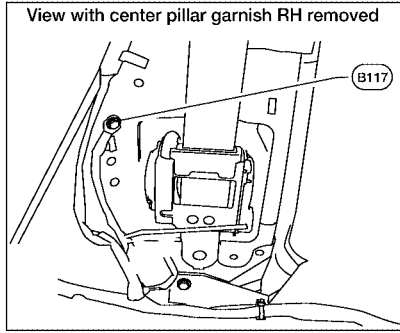

WKIA3433E

GROUND CIRCUIT

BACK DOOR NO. 2 HARNESS

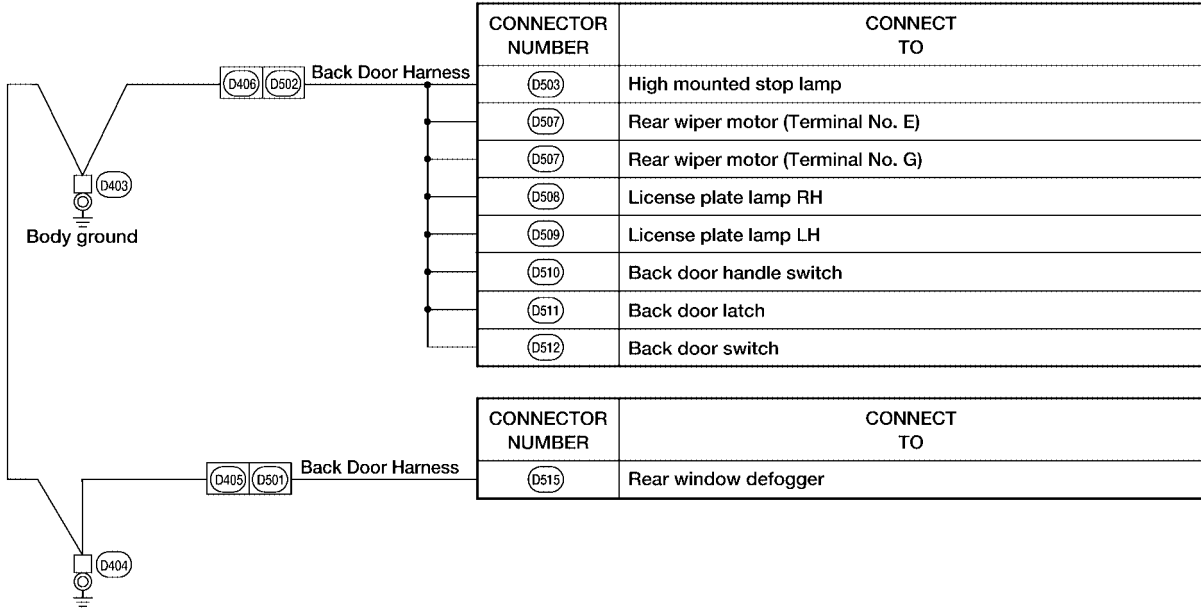
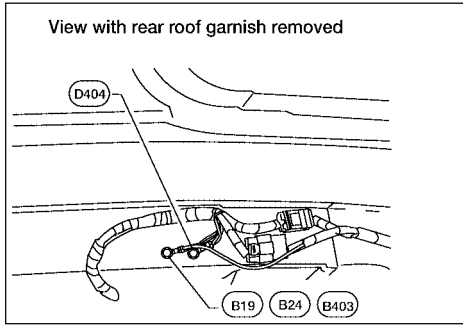

WKIA1218E

A
B
C
D
E
F
G
H
I
J
L
M

PG

HARNESS

PFP:24010

EKS0064N

HARNESS

Harness Layout

HOW TO READ HARNESS LAYOUT

The following Harness Layouts use a map style grid to help locate connectors on the drawings:

- Main Harness
- Engine Room Harness LH View (Engine Compartment)
- Engine Room Harness RH View (Engine Compartment)
- Engine Control Harness
- Body Harness and Rear Sonar Sensor Sub-Harness
- Body No. 2 Harness and Fuel Tank Sub-Harness

To use the grid reference

1. Find the desired connector number on the connector list.
2. Find the grid reference.
3. On the drawing, find the crossing of the grid reference letter column and number row.
4. Find the connector number in the crossing zone.
5. Follow the line (if used) to the connector.

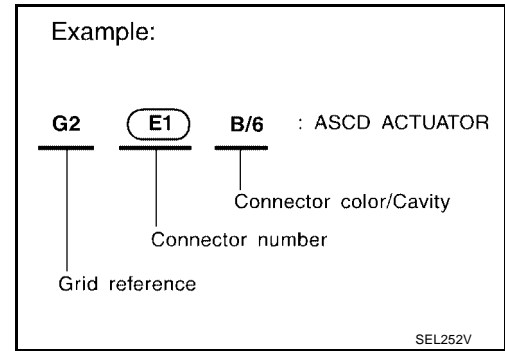

CONNECTOR SYMBOL

Main symbols of connector (in Harness Layout) are indicated below.

Connector type	Water proof type		Standard type	
	Male	Female	Male	Female
<ul style="list-style-type: none"> ● Cavity: 4 or Less ● Relay connector 				
<ul style="list-style-type: none"> ● Cavity: From 5 to 8 				
<ul style="list-style-type: none"> ● Cavity: 9 or More 				
<ul style="list-style-type: none"> ● Ground terminal etc. 	—			

HARNESS

OUTLINE

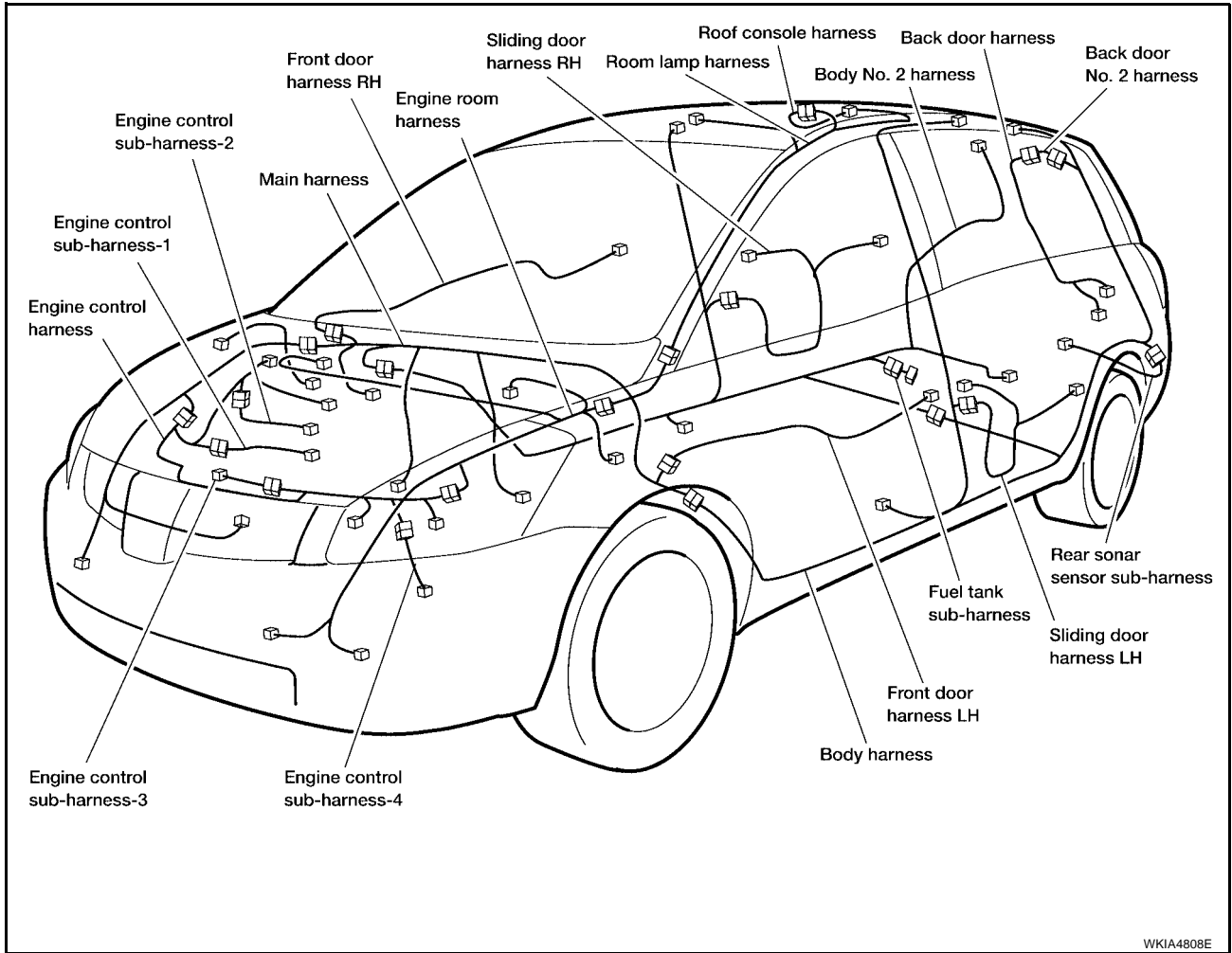

A
B
C
D
E
F
G
H
I
J

PG

L

M

HARNESS

MAIN HARNESS

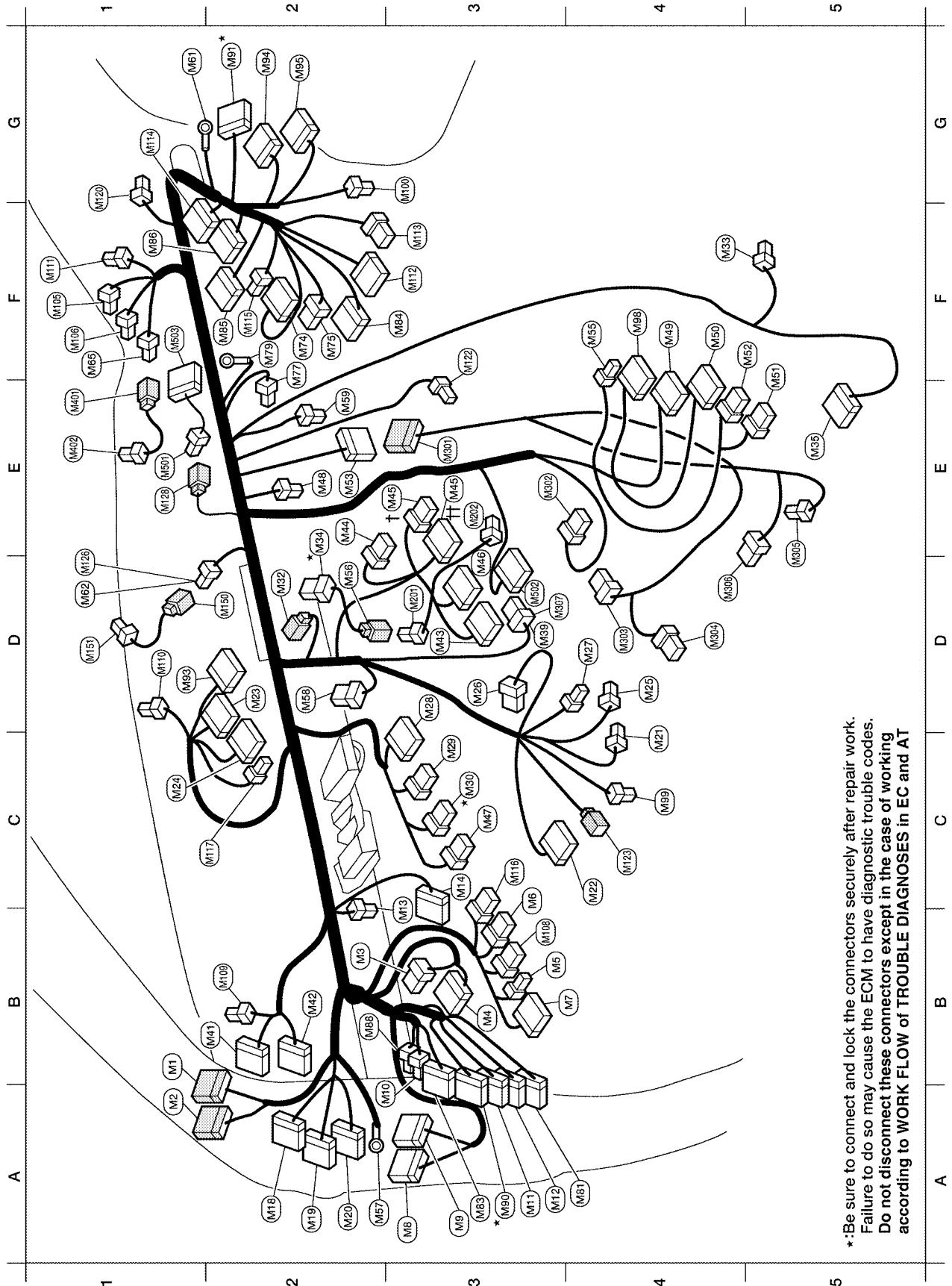

*:Be sure to connect and lock the connectors securely after repair work.
 Failure to do so may cause the ECM to have diagnostic trouble codes.
 Do not disconnect these connectors except in the case of working
 according to WORK FLOW of TROUBLE DIAGNOSES in EC and AT

WKIA4809E

HARNESS

ENGINE ROOM HARNESS (LH VIEW)

Engine Compartment

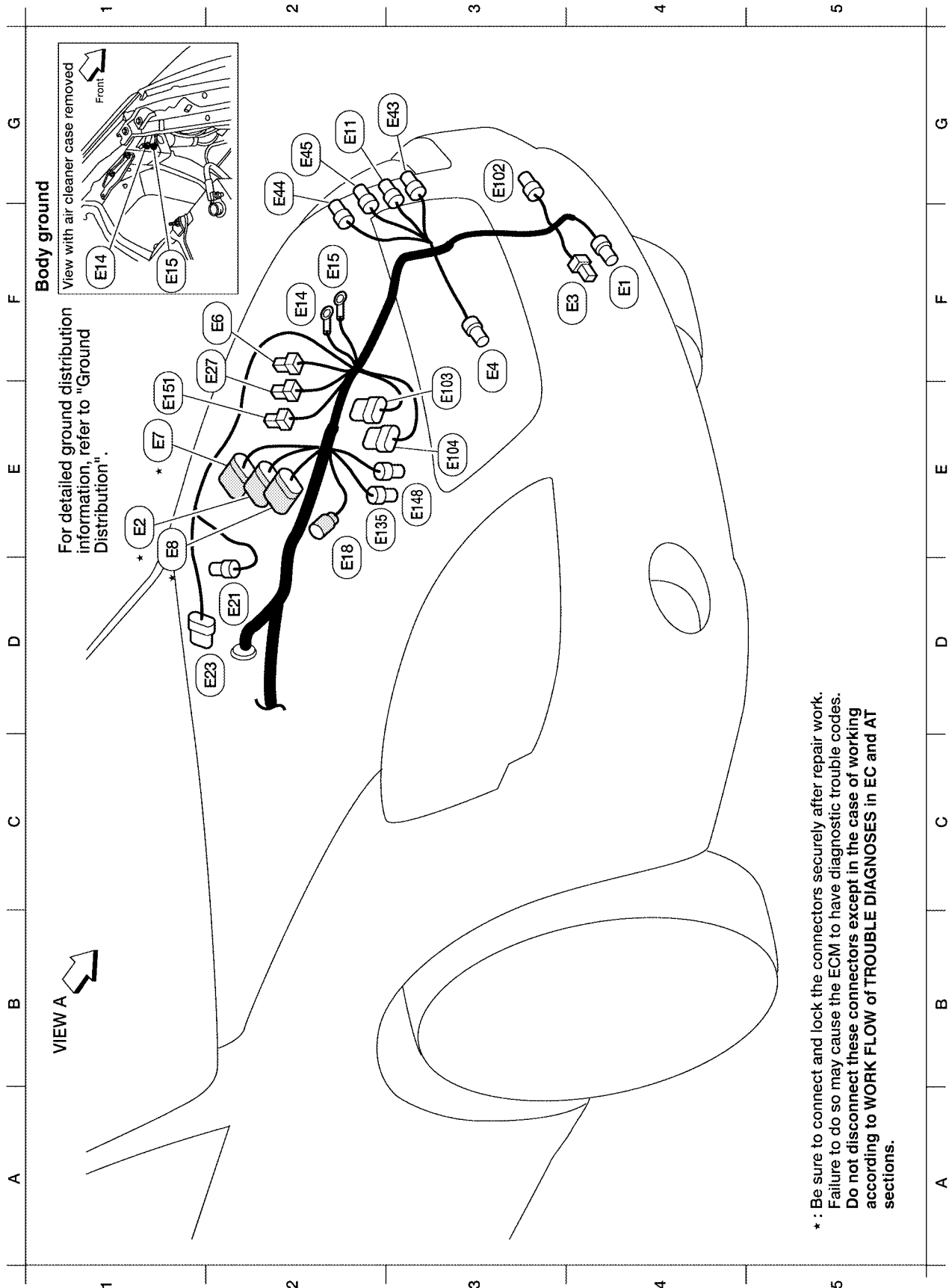

Refer to [PG-47, "ENGINE ROOM HARNESS \(RH VIEW\)"](#) for continuation of engine room harness.

LKIA0363E

HARNESS

F4	(E1)	B/2	: Ambient sensor
E1 *	(E2)	GR/10	: To (F32)
F4	(E3)	B/1	: Horn (low)
F3	(E4)	Y/2	: Crash zone sensor
F2	(E6)	GR/2	: Fusible link box (battery)
E1 *	(E7)	G/10	: To (F15) (with 5 A/T)
E1 *	(E8)	B/12	: To (F17)
G2	(E11)	GR/3	: Front combination lamp LH
F2	(E14)	-	: Body ground
F2	(E19)	-	: Body ground
D2	(E18)	B/2	: Front wheel sensor LH
D2	(E21)	GR/2	: Brake fluid level switch
D2	(E23)	GR/6	: Front wiper motor
F2	(E27)	BR/2	: Fusible link box (battery)
G3	(E43)	GR/2	: Cornering lamp LH
G2	(E44)	BR/2	: Headlamp LH (low)
G2	(E45)	B/2	: Headlamp LH (high)
G3	(E102)	B/2	: Front fog lamp LH
F3	(E103)	GR/8	: Daytime light control unit
E3	(E104)	GR/6	: Daytime light control unit
E3	(E135)	GR/2	: Dropping resistor (with 4 A/T)
E3	(E148)	W/3	: Daytime light relay
E1	(E151)	B/1	: To (F66)

*: Be sure to connect and lock the connectors securely after repair work.
 Failure to do so may cause the ECM to have diagnostic trouble codes.
Do not disconnect these connectors except in the case of working according to WORK FLOW of TROUBLE DIAGNOSES in EC and AT sections.

A
B
C
D
E
F
G
H
I
J
PG
L
M

HARNESS

Passenger Compartment

- * (E20) B/8 : Accelerator pedal position (APP) sensor
- (E25) W/24 : To (M90)
- (E29) W/4 : To (M10)
- * (E30) W/8 : Fuse block J/B
- (E31) B/2 : Fuse block J/B
- (E32) B/1 : Fuse block J/B
- * (E37) BR/2 : ASCD brake switch
- * (E38) W/4 : Stop lamp switch
- (E42) Y/4 : To (M88)
- (E109) GR/2 : Pedal adjusting motor
- (E110) W/3 : Pedal adjusting motor
- (E134) W/12 : To (M83)
- (E140) B/1 : Parking brake switch
- (E141) W/2 : To (B40)
- (E145) W/8 : To (B41)
- (E146) /3 : Diode-3
- (E147) /2 : Diode-1
- (E149) /2 : Diode-4

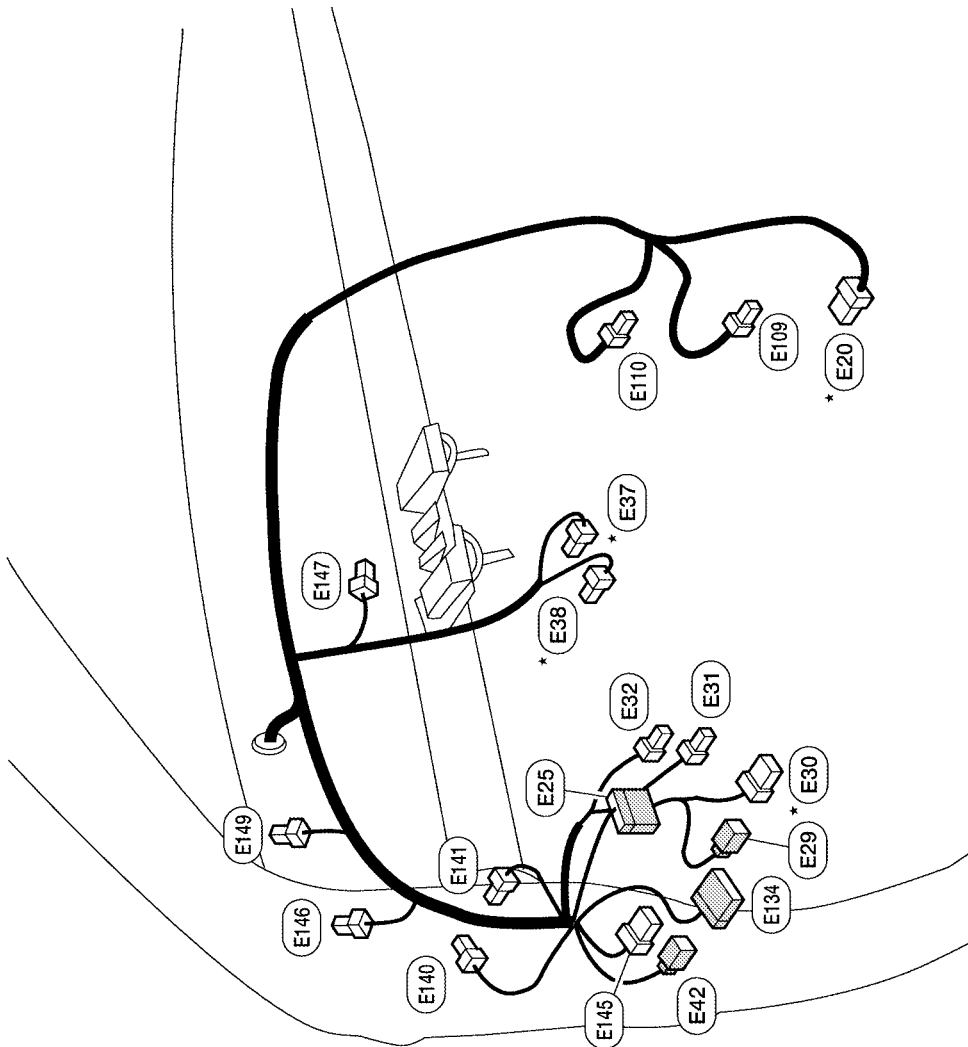

* : Be sure to connect and lock the connectors securely after repair work. Failure to do so may cause the ECM to have diagnostic trouble codes.
 Do not disconnect these connectors except in the case of working according to WORK FLOW of TROUBLE DIAGNOSES in EC and AT sections.

LKIA0365E

HARNESS

ENGINE ROOM HARNESS (RH VIEW) Engine Compartment

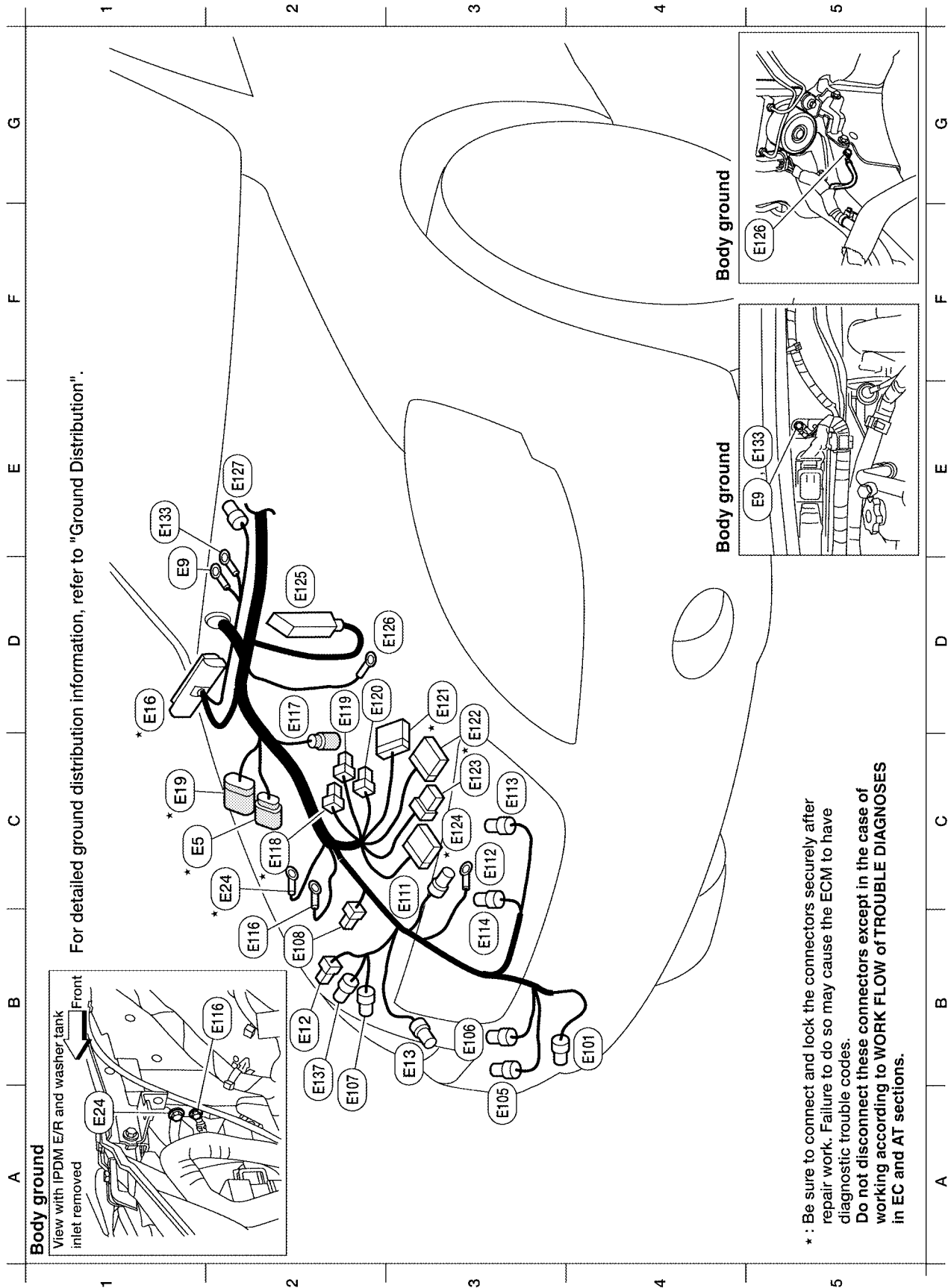

Refer to [PG-44, "ENGINE ROOM HARNESS \(LH VIEW\)"](#) for continuation of engine room harness.

HARNESS

C1	* E5	B/8	:	To	F14
D1	E9	-	:	Body ground	
B2	E12	BR/2	:	Headlamp RH (low)	
B3	E13	B/2	:	Headlamp RH (high)	
D1	* E16	B/32	:	ECM	
C1	* E19	GR/9	:	To	F33
C3	* E24	-	:	Body ground	
B4	E101	B/2	:	Front fog lamp RH	
A3	E105	GR/2	:	Washer motor	
B3	E106	BR/2	:	Washer fluid level switch	
A2	E107	GR/3	:	Front combination lamp RH	
B2	E108	B/1	:	Horn (high)	
C3	E111	B/3	:	Refrigerant pressure sensor	
C3	E112	-	:	Generator (ground)	
C3	E113	GR/4	:	Cooling fan motor-1	
B3	E114	GR/4	:	Cooling fan motor-2	
B2	E116	-	:	Body ground	
D2	E117	GR/2	:	Front wheel sensor RH	
C2	* E118	B/4	:	IPDM E/R (Intelligent Power Distribution Module Engine Room)	
D2	E119	W/4	:	IPDM E/R (Intelligent Power Distribution Module Engine Room)	
D2	E120	B/2	:	IPDM E/R (Intelligent Power Distribution Module Engine Room)	
D3	* E121	W/16	:	IPDM E/R (Intelligent Power Distribution Module Engine Room)	
D3	* E122	GR/16	:	IPDM E/R (Intelligent Power Distribution Module Engine Room)	
C3	E123	W/6	:	IPDM E/R (Intelligent Power Distribution Module Engine Room)	
C3	* E124	W/12	:	IPDM E/R (Intelligent Power Distribution Module Engine Room)	
D2	E125	GR/30	:	ABS actuator and electric unit (control unit) (without VDC)	
D2	E125	B/46	:	ABS actuator and electric unit (control unit) (with VDC)	
D3	E126	-	:	Body ground	
E2	E127	B/2	:	Heater pump	
E1	E133	-	:	Body ground	
B2	E137	GR/2	:	Cornering lamp RH	

*: Be sure to connect and lock the connectors securely after repair work.
 Failure to do so may cause the ECM to have diagnostic trouble codes.
Do not disconnect these connectors except in the case of working according to WORK FLOW of TROUBLE DIAGNOSES in EC and AT sections.

WKIA3438E

HARNESS

Passenger Compartment

- * E26 BR/16 : To M91
- E128 L/4 : Heater pump relay
- * E138 W/20 : To E106
- * E139 W/6 : To E107
- * E142 W/24 : TCM (with 4 A/T)
- * E142 GR/28 : TCM (with 5 A/T)
- * E143 GR/24 : TCM (with 4 A/T)
- * E143 GR/20 : TCM (with 5 A/T)
- * E144 L/4 : A/T PV IGN relay

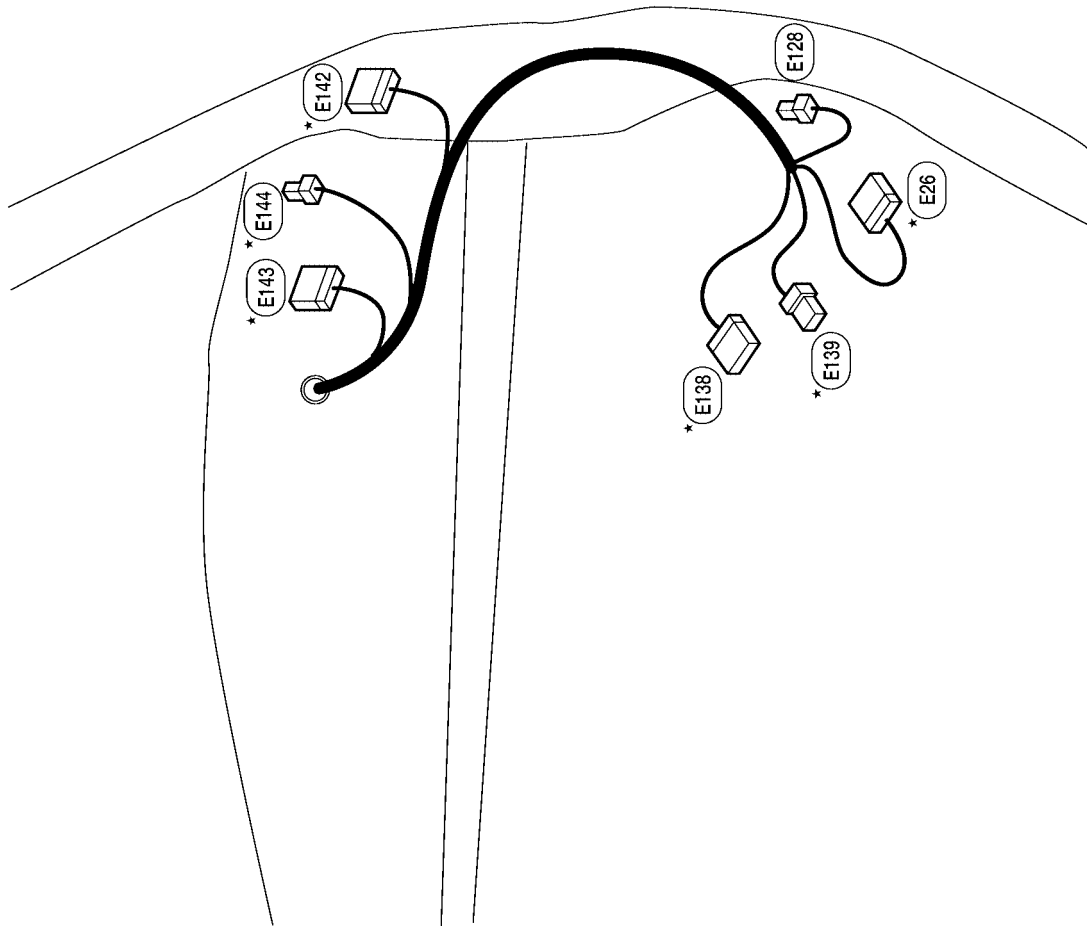

* : Be sure to connect and lock the connectors securely after repair work. Failure to do so may cause the ECM to have diagnostic trouble codes.
 Do not disconnect these connectors except in the case of working according to WORK FLOW of TROUBLE DIAGNOSES in EC and AT sections.

A
B
C
D
E
F
G
H
I
J
L
M

PG

WKIA2966E

HARNESS

ENGINE CONTROL HARNESS

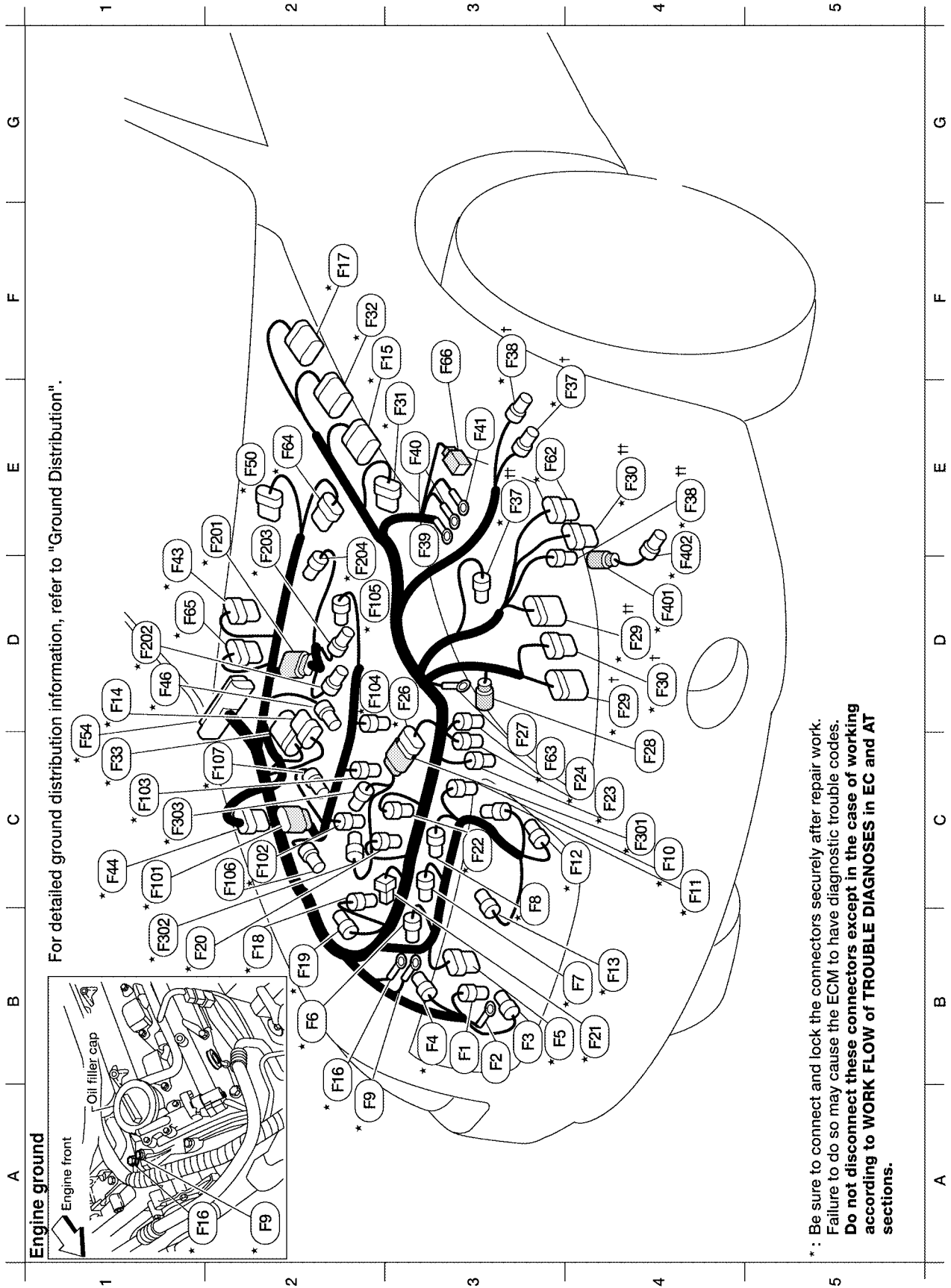

WKIA4812E

B3	(F1)	W/2	: Generator	E4	*(F30) ^{††} BR/8	: Terminal cord assembly (with 5 A/T)	C2	*(F106)	B/1	: Oil pressure switch	
B3	(F2)	-	: Generator	D4	*(F30) [†] B/8	: Terminal cord assembly (with 4 A/T)	C2	*(F107)	G/2	: Intake valve timing control solenoid valve (Bank 1)	
B3	(F3)	B/1	: A/C compressor	E3	*(F31)	B/6	Engine control sub-harness-2				
B3	*(F4)	G/2	: Intake valve timing control solenoid valve (Bank 2)	F2	*(F32)	GR/10	To (E2)	E2	*(F201)	G/6	To (F43)
B3	*(F5)	B/6	: Air fuel ratio (A/F) sensor (Bank 2)	C1	*(F33)	GR/9	To (E19)	D1	*(F202)	GR/3	: Ignition coil No. 1 (with power transistor)
B2	*(F6)	GR/3	: Ignition coil No. 2 (with power transistor)	E3	*(F37) ^{††} L/2	: Turbine revolution sensor (with 5 A/T)	E2	*(F203)	GR/3	: Ignition coil No. 3 (with power transistor)	
B4	*(F7)	GR/3	: Ignition coil No. 4 (with power transistor)	E4	*(F37) [†] B/3	: Turbine revolution sensor (with 4 A/T)	E2	*(F204)	GR/3	: Ignition coil No. 5 (with power transistor)	
C3	*(F8)	GR/3	: Ignition coil No. 6 (with power transistor)	E4	*(F38) ^{††} B/3	To (F40) [†] (with 5 A/T)	Engine control sub-harness-3				
A2	*(F9)	GR/3	: Engine ground	F3	*(F38) [†] B/3	: Revolution sensor (with 4 A/T)	C4	*(F301)	GR/6	To (F26)	
C4	*(F10)	BR/3	: Front electronic controlled engine mount	E3	*(F39)	-	B1	*(F302)	B/2	: Knock sensor	
C4	*(F11)	B/3	: Crankshaft position sensor (POS)	E3	(F40)	-	C1	*(F303)	G/3	: Camshaft position sensor (PHASE) (Bank 1)	
C3	*(F12)	G/4	: Heated oxygen sensor 2 (Bank 2)	E3	(F41)	-	Engine control sub-harness-4				
B4	*(F13)	G/4	: Heated oxygen sensor 2 (Bank 1)	D1	*(F43)	G/6	To (F20)	D4	*(F401)	GR/2	To (F38)
D1	*(F14)	B/8	To (E5)	C1	*(F44)	G/8	To (F10)	D4	*(F402)	L/2	: Revolution sensor (with 5 A/T)
F3	*(F15)	G/10	To (E7) (with 5 A/T)	D1	*(F46)	B/3	: Power steering pressure sensor				
B2	*(F16)	-	: Engine ground	E2	*(F50)	G/6	: Electric throttle control actuator				
F2	*(F17)	B/12	To (E8)	D1	*(F54)	B/7/6	: ECM				
B2	*(F18)	GR/2	: Injector No. 2	E4	*(F62)	GR/6	: Terminal cord assembly (with 5 A/T)				
B2	*(F19)	B/2	: VIAS control solenoid valve	C3	*(F63)	GR/2	: EGR temperature sensor				
B1	*(F20)	GR/2	: Injector No. 4	E2	*(F64)	GR/6	: EGR volume control valve				
B4	*(F21)	W/2	: Condenser-1	D1	*(F65)	B/6	: Air fuel ratio (A/F) sensor (Bank 1)				
C3	*(F22)	GR/2	: Injector No. 6	F3	(F66)	B/1	To (E15) [†]				
C4	(F23)	B/3	: Camshaft position sensor (PHASE) (Bank 2)	Engine control sub-harness-1							
C4	*(F24)	GR/2	: Engine coolant temperature sensor	C1	*(F101)	G/8	To (F44)				
D3	(F26)	GR/6	To (F30) [†]	C2	*(F102)	GR/2	: Injector No. 1				
C3	(F27)	-	: Starter motor	C1	*(F103)	GR/2	: Injector No. 3				
C4	*(F28)	GR/1	: Starter motor	D2	*(F104)	GR/2	: Injector No. 5				
D4	(F29) ^{††}	GR/10	: Park/neutral position (PNP) switch (with 5 A/T)	D2	*(F105)	L/2	: EVAP canister purge volume control solenoid valve				
D4	(F29) [†]	B/10	: Park/neutral position (PNP) switch (with 4 A/T)								

* Be sure to connect and lock the connectors securely after repair work. Failure to do so may cause the ECM to have diagnostic trouble codes. Do not disconnect these connectors except in the case of working according to WORK FLOW of TROUBLE DIAGNOSES in EC and AT sections.

HARNESS

BODY HARNESS

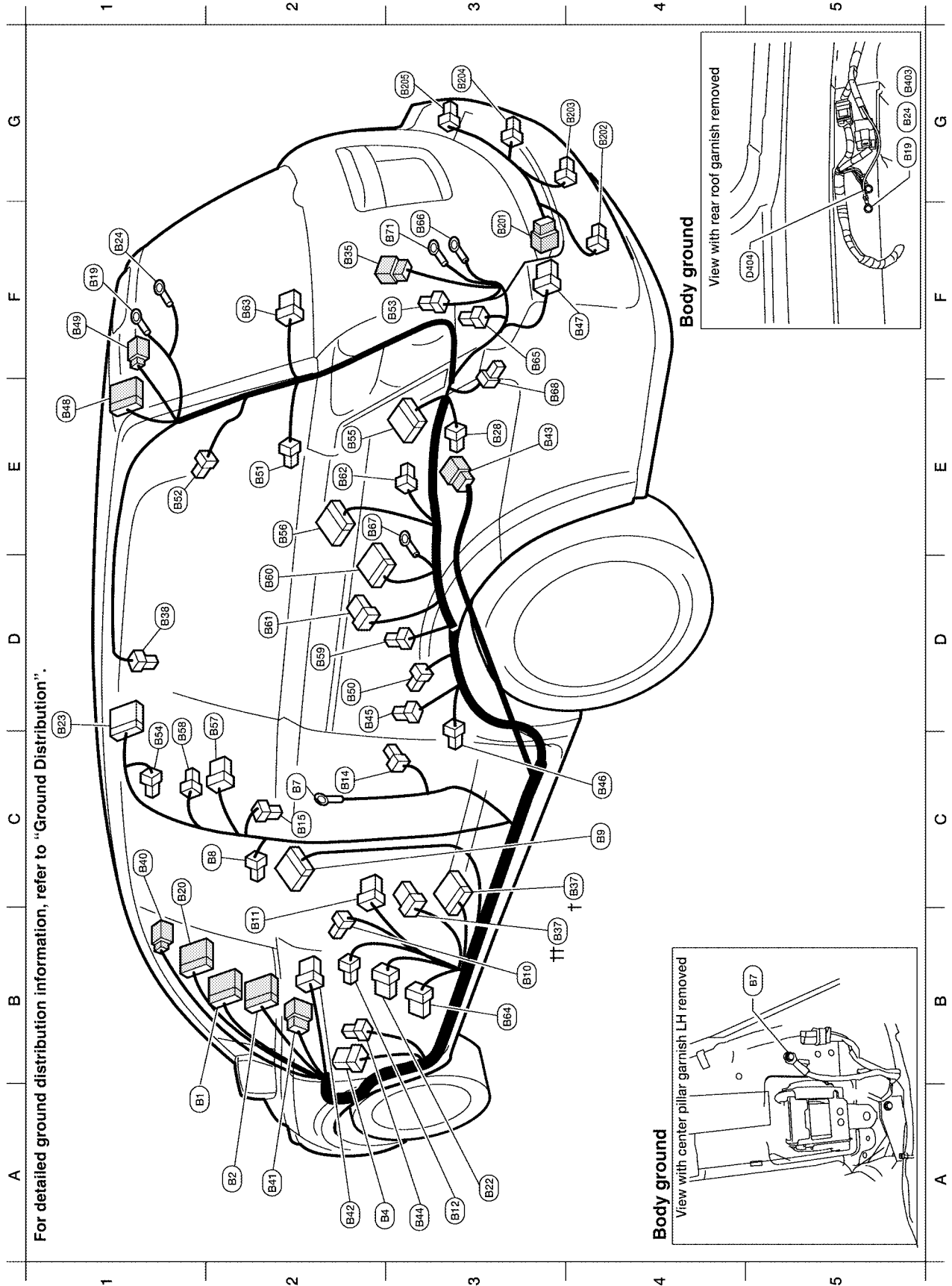

A1	(B1) W/16 : To (M11)	E1	(E48) W/24 : To (D40) (with power back door)
A2	(B2) GR/24 : To (M12)	F1	(E49) W/4 : To (G402)
A3	(B4) BR/6 : Rear window defogger relay	D2	(E50) B/3 : Rear power socket (2nd row)
C2	(B7) : Body ground	E2	(E61) B/3 : Rear power socket (cargo)
C2	(B8) W/3 : Front door switch LH	E1	(E52) W/2 : Rear power vent window motor LH
C4	(B9) Y/12 : Air bag diagnosis sensor unit	F3	(E53) GR/1 : To (E30) (trailer tow acc. sub-harness)
B3	(B10) Y/2 : Front LH side air bag module	C1	(E54) Y/2 : LH side curtain air bag module
B2	(B11) W/8 : Subwoofer	E2	(E56) W/26 : Back door control unit
A3	(B12) W/3 : Seat belt buckle switch LH	E2	(E56) W/16 : Sonar control unit
C2	(B14) Y/2 : Front LH seat belt pre-tensioner	C2	(E57) W/8 : Sliding door contact switch LH (pillar)
C2	(B15) Y/2 : LH side air bag (satellite) sensor	C1	(E58) W/4 : Sliding door open/close switch LH
F1	(B19) - : Body ground	D2	(E59) W/4 : Sliding door motor assembly LH (sliding door encoder LH)
C1	(B20) W/16 : To (M81)	D2	(E60) W/24 : Sliding door control unit LH
A3	(B22) W/6 : Pedal adjusting switch	D2	(E61) W/8 : Sliding door control unit LH
C1	(B23) W/16 : Rear audio remote control unit	E2	(E62) B/2 : Fuel door interlock switch
F1	(B24) - : Body ground	F2	(E63) GR/6 : Back door close switch
E3	(B26) W/4 : Fuel lid opener actuator	B3	(E64) BR/6 : Front heated seat switch LH
F2	(B36) W/6 : Rear combination lamp LH	F3	(E65) W/2 : Condenser-3
C4	(B37) W/16 : To (P1) (with memory seat)	F3	(E66) - : Body ground
B3	(B37) W/6 : To (P1) (w/o memory seat)	E2	(E67) - : Body ground
D1	(B38) Y/2 : LH side curtain air bag module	E4	(E68) W/2 : Condenser-4
C1	(B40) W/2 : To (E141)	F3	(E71) - : Body ground
A2	(B41) W/8 : To (E145)	Rear sonar system sensor sub-harness	
A2	(B42) W/6 : Fuse block (J/B)	F3	(E201) GR/6 : To (E47)
E3	(B43) W/8 : To (E111)	G4	(E202) B/3 : Rear sonar system sensor (LH outer)
A3	(B44) W/2 : Circuit breaker-2	G4	(E203) B/3 : Rear sonar system sensor (LH inner)
D2	(B45) W/2 : Rear speaker LH	G3	(E204) B/3 : Rear sonar system sensor (RH inner)
C4	(B46) W/3 : Sliding door switch LH	G3	(E205) B/3 : Rear sonar system sensor (RH outer)
F4	(B47) GR/6 : To (E201)		
E1	(B48) W/12 : To (D40) (without power back door)		

WKIA4815E

A
B
C
D
E
F
G
H
I
J
PG
L
M

HARNESS

BODY NO. 2 HARNESS

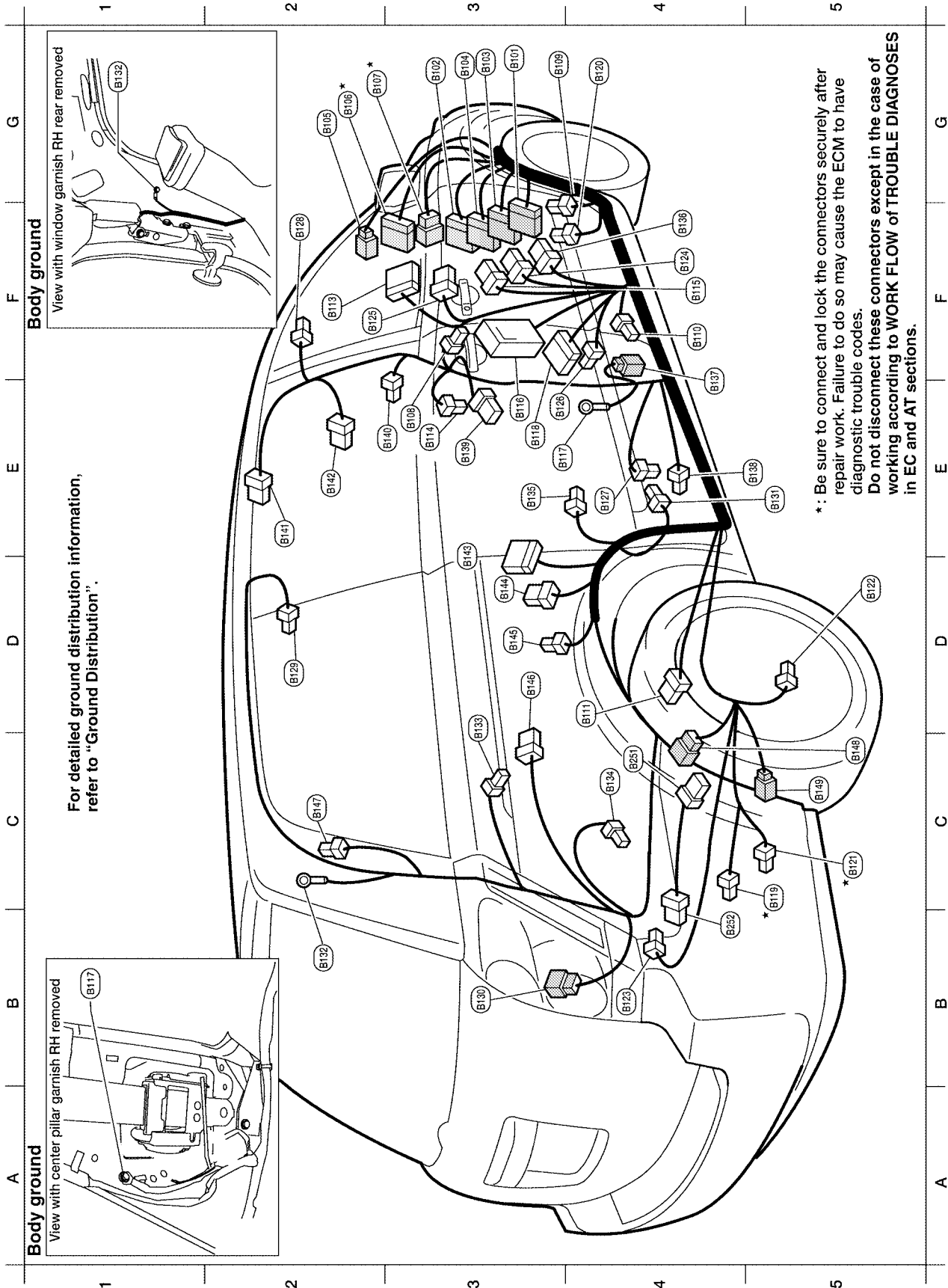

Body ground
View with window garnish RH rear removed

For detailed ground distribution information, refer to "Ground Distribution".

Body ground
View with center pillar garnish RH removed

*: Be sure to connect and lock the connectors securely after repair work. Failure to do so may cause the ECM to have diagnostic trouble codes. Do not disconnect these connectors except in the case of working according to **WORK FLOW of TROUBLE DIAGNOSES** in EC and AT sections.

WKIA3443E

G3	(B101)	W/16	: To (M84)
G3	(B102)	BR/24	: To (M85)
G3	(B103)	BR/20	: To (M86)
G3	(B104)	W/24	: To (M114)
G2	(B105)	W/4	: To (M115)
G2	(B106)	W/20	: To (E138)
G2	(B107)	W/6	: To (E139)
E3	(B108)	W/3	: Front door switch RH
G3	(B109)	L/4	: Heated seat relay
F4	(B110)	W/3	: Seat belt buckle switch RH
D4	(B111)	W/8	: To (B43)
F2	(B113)	Y/12	: Air bag diagnosis sensor unit
E3	(B114)	Y/2	: RH side air bag (satellite) sensor
F4	(B115)	W/6	: To (P101)
E3	(B116)	SMJ	: To (P102)
E3	(B117)		: Body ground
E3	(B118)	BR/24	: To (P103)
C5	(B119)	GR/3	: EVAP control system pressure sensor
G4	(B120)	W/2	: Circuit breaker-1
C5	(B121)	B/2	: EVAP canister vent control valve
D5	(B122)	GR/2	: Rear wheel sensor RH
B4	(B123)	L/2	: Rear wheel sensor LH
F4	(B124)	BR/6	: Front heated seat switch RH
F2	(B125)	B/6	: Yaw rate/side/decel G-sensor
F4	(B126)	Y/2	: Front RH side air bag module
E4	(B127)	Y/2	: Front RH seat belt pre-tensioner
F2	(B128)	Y/2	: RH side curtain air bag module
D2	(B129)	Y/2	: RH side curtain air bag module
B3	(B130)	W/6	: Rear combination lamp RH
E5	(B131)	W/2	: Rear speaker RH

B2	(B132)	-	: Body ground
C3	(B133)	B/4	: Rear blower motor resistor
C4	(B134)	B/2	: Rear blower motor
E3	(B135)	W/3	: Sliding door switch RH
G4	(B136)	W/8	: To (B15)
F4	(B137)	B/3	: Belt tension sensor
E5	(B138)	W/2	: Condenser-2
E3	(B139)	W/8	: Sliding door contact switch RH (pillar)
E2	(B140)	W/4	: Sliding door open/close switch RH
E2	(B141)	B/5	: Rear air control
E2	(B142)	W/6	: Rear air control
E3	(B143)	W/24	: Sliding door control unit RH
D3	(B144)	W/8	: Sliding door control unit RH
D3	(B145)	W/4	: Sliding door motor assembly RH (sliding door encoder RH)
D3	(B146)	B/6	: Air mix door rear
C2	(B147)	W/2	: Rear power vent window motor RH
C5	(B148)	GR/6	: To (B25)
C5	(B149)	GR/2	: Running board lamp pre-wiring

Fuel tank sub-harness

C4	(B251)	GR/6	: To (B148)
B4	(B252)	GR/5	: Fuel tank

* : Be sure to connect and lock the connectors securely after repair work. Failure to do so may cause the ECM to have diagnostic trouble codes.
Do not disconnect these connectors except in the case of working according to WORK FLOW of TROUBLE DIAGNOSES in EC and AT sections.

HARNESS

ROOM LAMP HARNESS

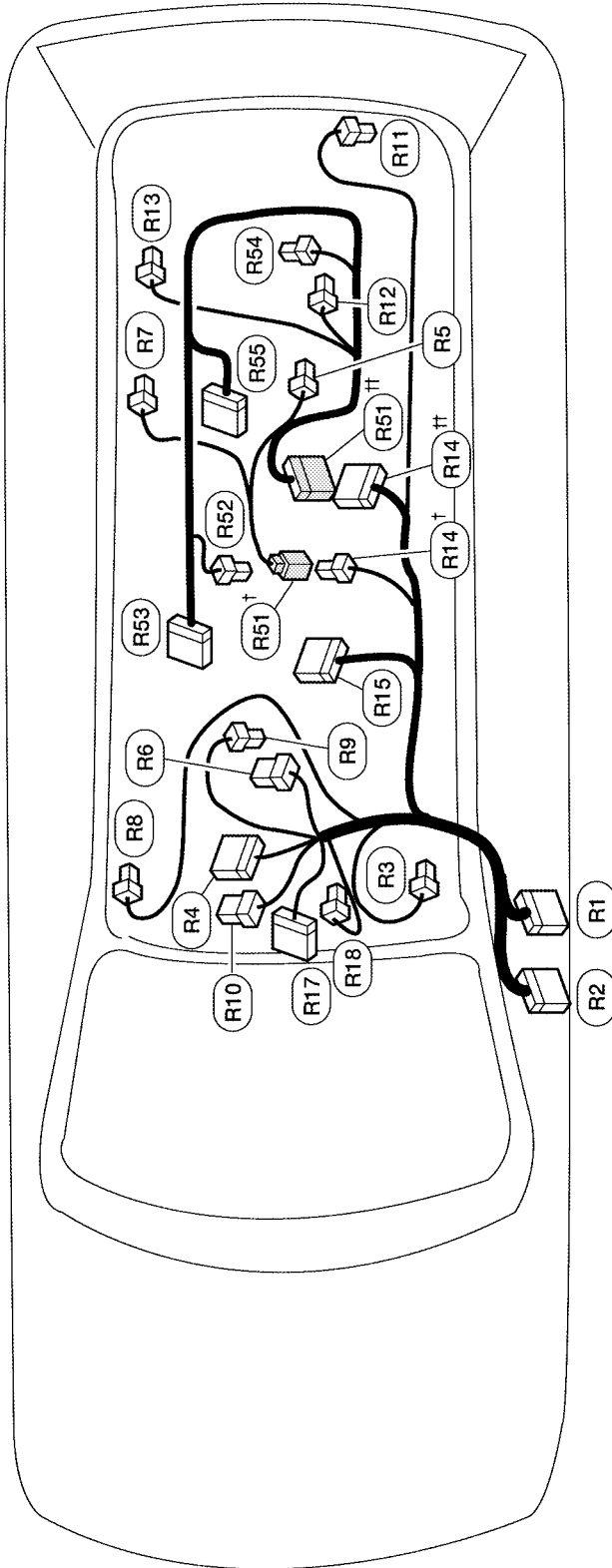

- | | | | |
|-----------|---|---------------------------------|---|
| (R1) W/16 | : To (M1) | (R14) W/4 | : To (R51) (without DVD entertainment system) |
| (R2) W/16 | : To (M2) (with DVD entertainment system) | (R14) W/24 | : To (R51) (with DVD entertainment system) |
| (R3) W/2 | : Vanity lamp LH | (R15) W/12 | : Video monitor (with DVD entertainment system except models with overhead console) |
| (R4) W/10 | : Sunroof motor | (R17) B/10 | : Auto anti-dazzling inside mirror |
| (R5) W/3 | : Personal lamp 2nd row LH (without overhead console) | (R18) W/2 | : Console lamp |
| (R6) GR/6 | : Sunroof switch | Overhead console harness | |
| (R7) W/3 | : Personal lamp 2nd row RH (without overhead console) | (R51) W/4 | : To (R14) (without DVD entertainment system) |
| (R8) W/2 | : Vanity lamp RH | (R51) W/24 | : To (R14) (with DVD entertainment system) |
| (R9) W/3 | : Room/map lamp | (R52) W/3 | : Personal lamp 2nd row |
| (R10) W/8 | : Automatic door main switch | (R53) W/12 | : Front video monitor |
| (R11) W/3 | : Cargo lamp | (R54) W/3 | : Personal lamp 3rd row |
| (R12) W/3 | : Personal lamp 3rd row LH (without overhead console) | (R55) W/12 | : Rear video monitor (with dual monitor DVD entertainment system) |
| (R13) W/3 | : Personal lamp 3rd row RH (without overhead console) | | |

WKIA3445E

HARNESS

FRONT DOOR LH HARNESS

- Ⓛ1 GR/12 : To Ⓛ9
- Ⓛ2 BR/24 : To Ⓛ6
- Ⓛ3 W/2 : Front door speaker LH
(without BOSE audio system)
- Ⓛ3 BR/2 : Front door speaker LH (with
BOSE audio system)
- Ⓛ4 W/8 : Door mirror LH
- Ⓛ5 W/8 : Seat memory switch
- Ⓛ6 W/4 : Fuel lid opener switch
- Ⓛ7 W/16 : Main power window and door
lock/unlock switch
- Ⓛ8 W/3 : Main power window and door
lock/unlock switch
- Ⓛ9 GR/6 : Front power window motor LH
- Ⓛ11 W/2 : Front step lamp LH
- Ⓛ13 W/6 : Door mirror LH
- Ⓛ14 B/6 : Front door lock actuator LH (front
door key cylinder switch LH)

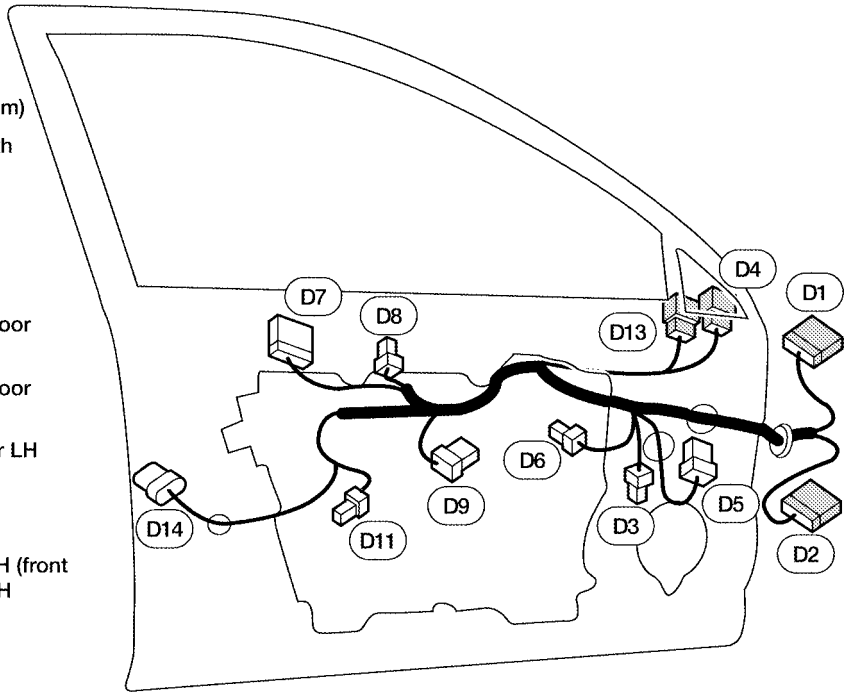

LKIA0378E

FRONT DOOR RH HARNESS

- Ⓛ101 W/8 : To Ⓛ75
- Ⓛ102 W/16 : To Ⓛ74
- Ⓛ103 W/2 : Front door speaker RH (without BOSE audio system)
- Ⓛ103 BR/2 : Front door speaker RH (with BOSE audio system)
- Ⓛ104 GR/6 : Front power window motor RH
- Ⓛ105 W/16 : Power window and door lock/unlock
switch RH
- Ⓛ107 W/8 : Door mirror RH
- Ⓛ109 W/2 : Front step lamp RH
- Ⓛ113 W/6 : Door mirror RH
- Ⓛ114 B/6 : Front door lock actuator RH

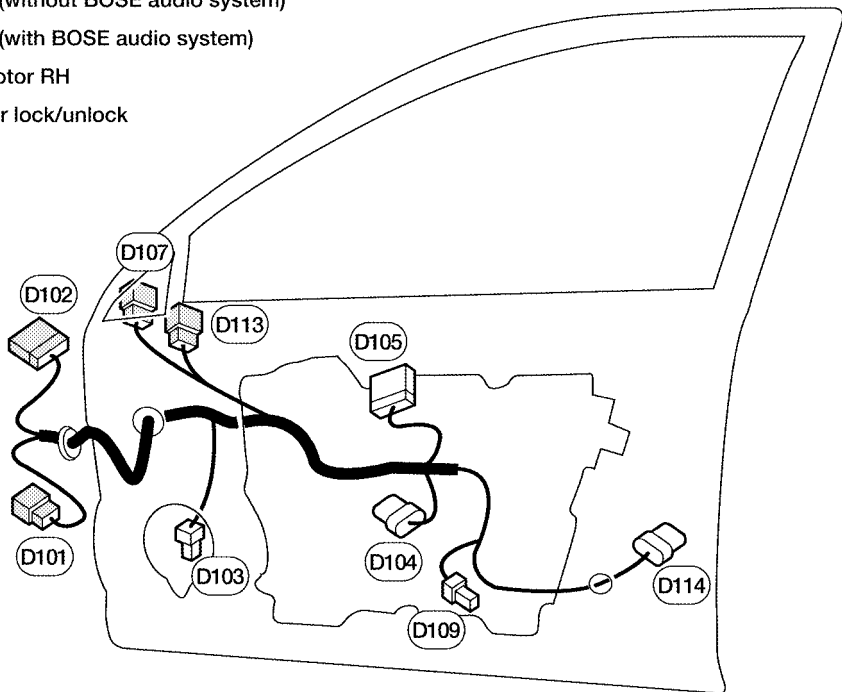

LKIA0379E

A
B
C
D
E
F
G
H
I
J
PG
L
M

HARNESS

SLIDING DOOR LH HARNESS

- (D201) GR/8 : Sliding door contact switch LH
- (D202) W/4 : Cinch latch switch LH
- (D203) W/2 : Cinch latch motor LH
- (D204) W/10 : Sliding door latch control unit
- (D205) GR/4 : Sliding door lock actuator LH
- (D206) W/2 : Latch release actuator LH
- (D207) W/3 : Sliding door remote control switch LH

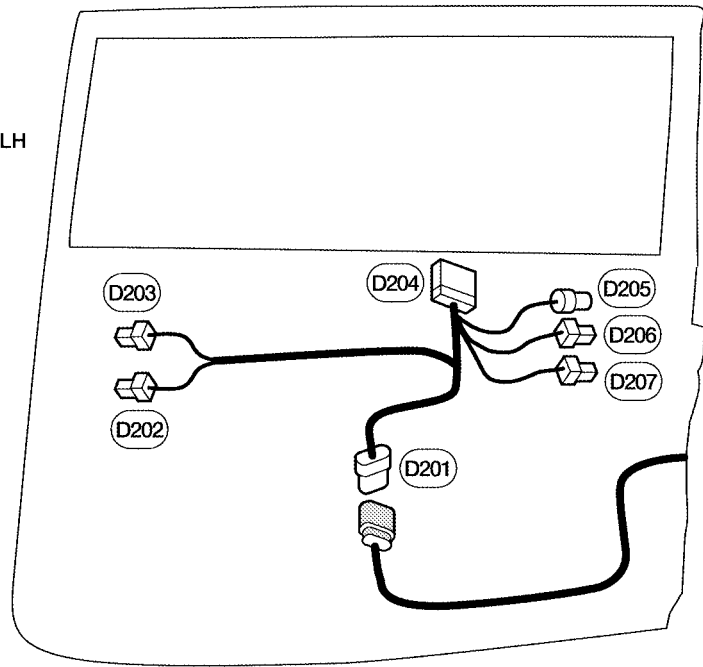

LKIA0380E

SLIDING DOOR RH HARNESS

- (D301) GR/8 : Sliding door contact switch RH
- (D302) W/4 : Cinch latch switch RH
- (D303) W/2 : Cinch latch motor RH
- (D304) W/10 : Sliding door latch control unit RH
- (D305) GR/4 : Sliding door lock actuator RH
- (D306) W/2 : Latch release actuator RH
- (D307) W/3 : Sliding door remote control switch RH

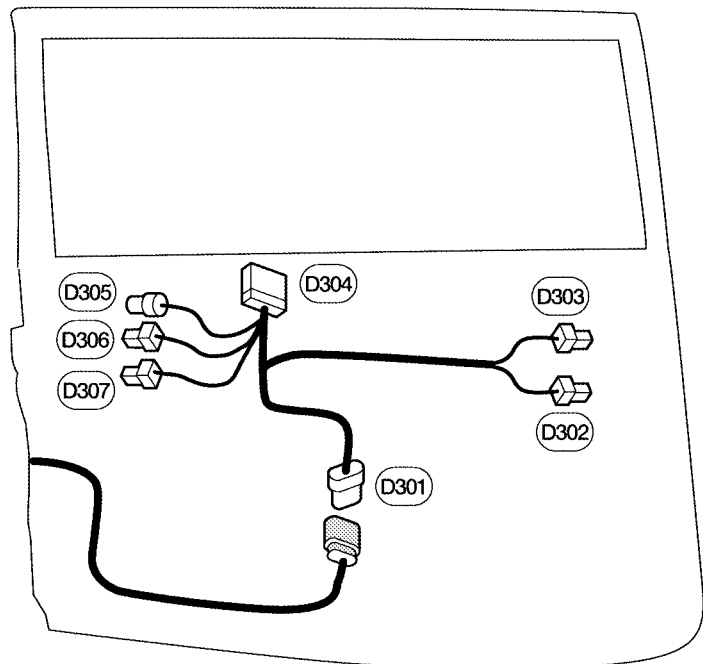

LKIA0381E

HARNESS

BACK DOOR HARNESS

Body ground

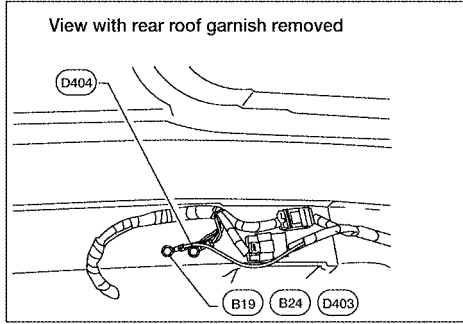

For detailed ground distribution information, refer to "Ground Distribution".

Back door No.2 harness

- (D401) W/12 : To (B48) (without power back door)
- (D401) W/24 : To (B48) (with power back door)
- (D402) W/6 : To (B49)
- (D403) - : Body ground
- (D404) - : Body ground
- (D405) W/6 : To (D501)
- (D406) W/12 : To (D502) (without power back door)
- (D406) W/24 : To (D502) (with power back door)

Back door harness

- (D501) W/6 : To (D405)
- (D502) W/12 : To (D406) (without power back door)
- (D502) W/24 : To (D406) (with power back door)
- (D503) W/2 : High mounted stop lamp
- (D504) B/1 : Rear window defogger (+)
- (D505) BR/2 : Pinch strip RH
- (D506) BR/2 : Rear tweeter RH
- (D507) W/4 : Rear wiper motor
- (D508) BR/2 : License lamp RH
- (D509) BR/2 : License lamp LH
- (D510) GR/2 : Back door handle switch

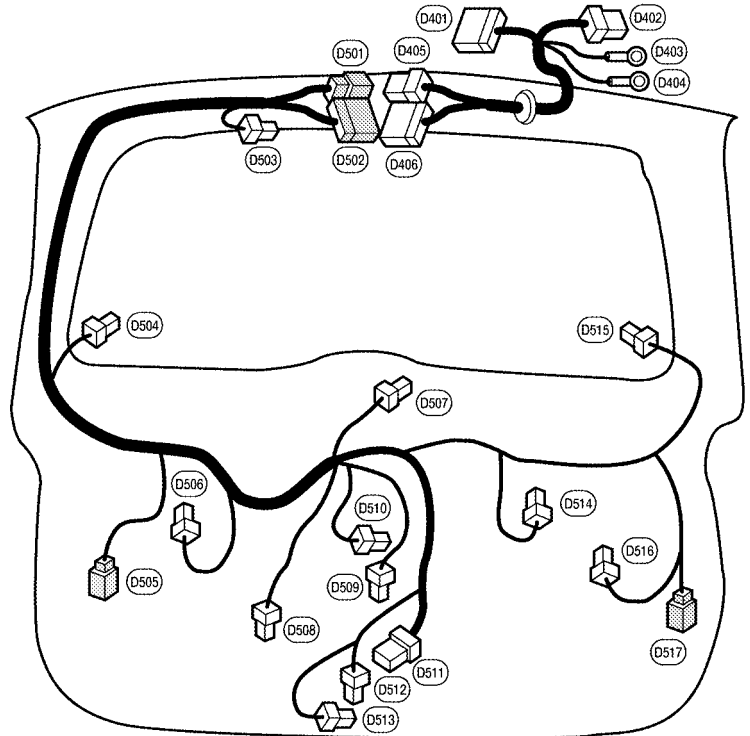

- (D511) W/8 : Back door latch
- (D512) W/3 : Back door switch
- (D513) W/4 : Back door lock actuator
- (D514) BR/2 : Back door warning chime
- (D515) B/1 : Rear window defogger (-)
- (D516) BR/2 : Rear tweeter LH
- (D517) BR/2 : Pinch strip LH

WKIA4817E

A
B
C
D
E
F
G
H
I
J
PG
L
M

HARNESS

EKS00640

Wiring Diagram Codes (Cell Codes)

Use the chart below to find out what each wiring diagram code stands for.

Refer to the wiring diagram code in the alphabetical index to find the location (page number) of each wiring diagram.

Code	Section	Wiring Diagram Name
1STSIG	AT	A/T 1st Signal
2NDSIG	AT	A/T 2nd Signal
3RDSIG	AT	A/T 3rd Signal
4THSIG	AT	A/T 4th Signal
5THSIG	AT	A/T 5th Signal
A/C,A	ATC	Auto Air Conditioner
A/C,M	MTC	Manual Air Conditioner
AF1B1	EC	Air Fuel Ratio Sensor 1 Bank 1
AF1B2	EC	Air Fuel Ratio Sensor 1 Bank 2
AF1HB1	EC	Air Fuel Ratio Sensor 1 Heater Bank 1
AF1HB2	EC	Air Fuel Ratio Sensor 1 Heater Bank 2
APPS1	EC	Accelerator Pedal Position Sensor
APPS2	EC	Accelerator Pedal Position Sensor
APPS3	EC	Accelerator Pedal Position Sensor
ASC/BS	EC	ASCD Brake Switch
ASC/SW	EC	ASCD Steering Switch
ASCBOF	EC	ASCD Brake Switch
ASCIND	EC	ASCD Indicator
AT/IND	DI	A/T Indicator Lamp
AUDIO	AV	Audio
AUT/DP	SE	Automatic Drive Positioner
AUTO/L	LT	Auto Light Control
B/CLOS	BL	Back Door Auto Closure System
BA/FTS	AT	A/T Fluid Temperature Sensor and TCM Power Supply
BACK/L	LT	Back-up Lamp
BRK/SW	EC	Brake Switch
CAN	AT	CAN Communication Line
CAN	EC	CAN Communication Line
CAN	LAN	CAN System
CHARGE	SC	Charging System
CHIME	DI	Warning Chime
COOL/F	EC	Cooling Fan Control
COMBSW	LT	Combination Switch
COMM	AV	Audio Visual Communication System
CORNER	LT	Cornering Lamps
D/LOCK	BL	Power Door Lock
DEF	GW	Rear Window Defogger
DTRL	LT	Headlamp - With Daytime Light System
DVD	AV	DVD Entertainment System
ECM/PW	EC	ECM Power Supply for Back-Up
ECTS	EC	Engine Coolant Temperature Sensor
EGR/TS	EC	EGR Temperature Sensor
EGRC1	EC	EGR Function
EGVC/V	EC	EGR Volume Control Valve
EMNT	EC	Engine Mount
ENGSS	AT	Engine Speed Signal
ETC1	EC	Electric Throttle Control Function

HARNESSES

ETC2	EC	Throttle Control Motor Relay	A
ETC3	EC	Throttle Control Motor	
F/FOG	LT	Front Fog Lamp	
F/LID	BL	Fuel Lid Opener	B
F/PUMP	EC	Fuel Pump	
FTS	AT	A/T Fluid Temperature Sensor	
FTSP	AT	A/T Fluid Temperature Sensor Failure	C
FTTS	EC	Fuel Tank Temperature Sensor	
FUELB1	EC	Fuel Injection System Bank 1	
FUELB2	EC	Fuel Injection System Bank 2	D
H/LAMP	LT	Headlamp	
HORN	WW	Horn	
HSEAT	SE	Heated Seat	E
I/MIRR	GW	Inside Mirror (Auto Anti-Dazzling Mirror)	
IATS	EC	Intake Air Temperature Sensor	
IGNSYS	EC	Ignition System	F
ILL	LT	Illumination	
INF/D	AV	Vehicle Information and Integrated Switch System	
INJECT	EC	Injector	G
INT/L	LT	Room/Map, Vanity, Cargo, Personal, Foot, Step, Puddle and Running Board Lamps	
IVCB1	EC	Intake Valve Timing Control Solenoid Valve Bank 1	H
IVCB2	EC	Intake Valve Timing Control Solenoid Valve Bank 2	
KEYLES	BL	Remote Keyless Entry System	
KS	EC	Knock Sensor	I
LPSV	AT	Line Pressure Solenoid Valve	
LVRSW	AT	A/T Device Lever Switch	J
MAFS	EC	Mass Air Flow Sensor	
MAIN	AT	Main Power Supply and Ground Circuit	
MAIN	EC	Main Power Supply and Ground Circuit	
METER	DI	Speedometer, Tachometer, Temp. and Fuel Gauges	PG
MIL/DL	EC	Malfunction Indicator Lamp	
MIRROR	GW	Door Mirror	
NATS	BL	Nissan Anti-Theft System	L
NAVI	AV	Navigation System	
NONDTC	AT	Non-detectable Items	
O2H2B1	EC	Rear Heated Oxygen Sensor 2 Heater Bank 1	M
O2H2B2	EC	Rear Heated Oxygen Sensor 2 Heater Bank 2	
O2S2B1	EC	Heated Oxygen Sensor 2 Bank 1	
O2S2B2	EC	Heated Oxygen Sensor 2 Bank 2	
OVRCV	AT	Overrun Clutch Solenoid Valve	
P/SCKT	WW	Power Socket	
PC/A	AT	Line Pressure Solenoid Valve	
PC/B	AT	Shift Pressure Solenoid Valve	
PC/C	AT	Pressure Control Solenoid Valve	
PC/CS	AT	Pressure Control Solenoid Valve Failure	
PEDAL	AP	Adjustable Pedal System	
PGC/V	EC	EVAP Canister Purge Volume Control Solenoid Valve	
PHSB1	EC	Camshaft Position Sensor (PHASE) (Bank 1)	
PHSB2	EC	Camshaft Position Sensor (PHASE) (Bank 2)	
PNP/SW	AT	Park/Neutral Position Switch	
PNP/SW	EC	Park/Neutral Position Switch	

HARNESSES

POS	EC	Crankshaft Position Sensor (POS)
POWER	PG	Power Supply Routing
PRE/SE	EC	EVAP Control System Pressure Sensor
PS/SEN	EC	Power Steering Pressure Sensor
PWR/IN	AT	TCM Ignition Power
RP/SEN	EC	Refrigerant Pressure Sensor
S/CLOS	BL	Slide Door Auto Closure System
SEAT	SE	Power Seat
SEN/PW	EC	Sensor Power Supply
SFTFNC	AT	Unusual Shifting
SHIFT	AT	A/T Shift Lock System
SONAR	DI	Rear Sonar System
SROOF	RF	Sunroof
SRS	SRS	Supplemental Restraint System
SSV/A	AT	Shift Solenoid Valve A
SSV/B	AT	Shift Solenoid Valve B
SSV/C	AT	Shift Solenoid Valve C
SSV/CS	AT	Shift Solenoid Valve C Failure
SSV/D	AT	Shift Solenoid Valve D
SSV/E	AT	Shift Solenoid Valve E
START	SC	Starting System
STOP/L	LT	Stop Lamp
T/TOW	LT	Trailer Tow
T/WARN	WT	Low Tire Pressure Warning System
TAIL/L	LT	Parking, License and Tail Lamps
TCCSIG	AT	A/T TCC Signal (Lock Up)
TCS	BRC	Traction Control System
TCV	AT	Torque Converter Clutch Solenoid Valve
TPS	AT	Throttle Position Sensor
TPS1	EC	Throttle Position Sensor
TPS2	EC	Throttle Position Sensor
TPS3	EC	Throttle Position Sensor
TRNSCV	BL	HOMELINK® Universal Transceiver
TRS/AT	AT	Turbine Revolution Sensor
TRSC	AT	Turbine Revolution Sensor
TURN	LT	Turn Signal and Hazard Warning Lamps
VDC	BRC	Vehicle Dynamic Control System
VEHSEC	BL	Vehicle Security (Theft Warning) System
VENT/V	EC	EVAP Canister Vent Control Valve
VIAS	EC	Variable Air Induction Control System
VIAS/V	EC	Variable Air Induction Control System Valve
VSS/AT	AT	Vehicle Speed Sensor A/T (Revolution Sensor)
VSS/ATC	AT	Revolution Sensor
VSS/MTR	AT	Vehicle Speed Sensor Meter
W/ANT	AV	Audio Antenna
WARN	DI	Warning Lamps
WINDOW	GW	Power Window
WIP/R	WW	Rear Wiper and Washer
WIPER	WW	Front Wiper and Washer

ELECTRICAL UNITS LOCATION

ELECTRICAL UNITS LOCATION

PFP:25230

Electrical Units Location ENGINE COMPARTMENT

EKS0064P

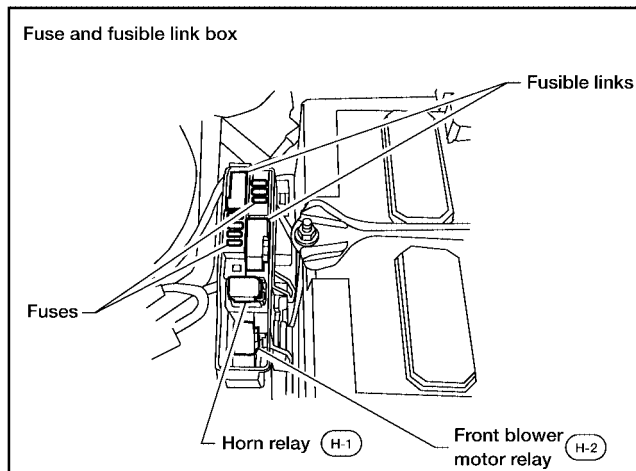
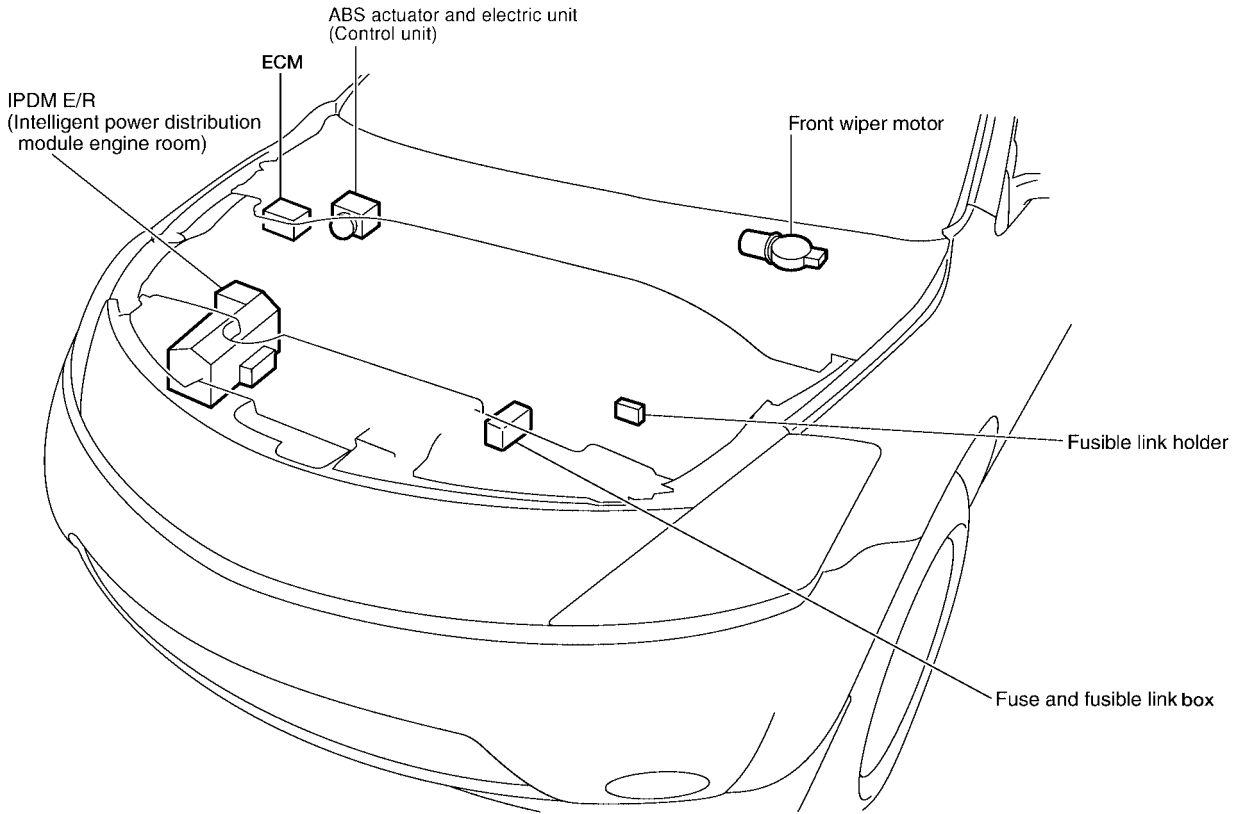

A
B
C
D
E
F
G
H
I
J

PG

L
M

ELECTRICAL UNITS LOCATION

PASSENGER COMPARTMENT

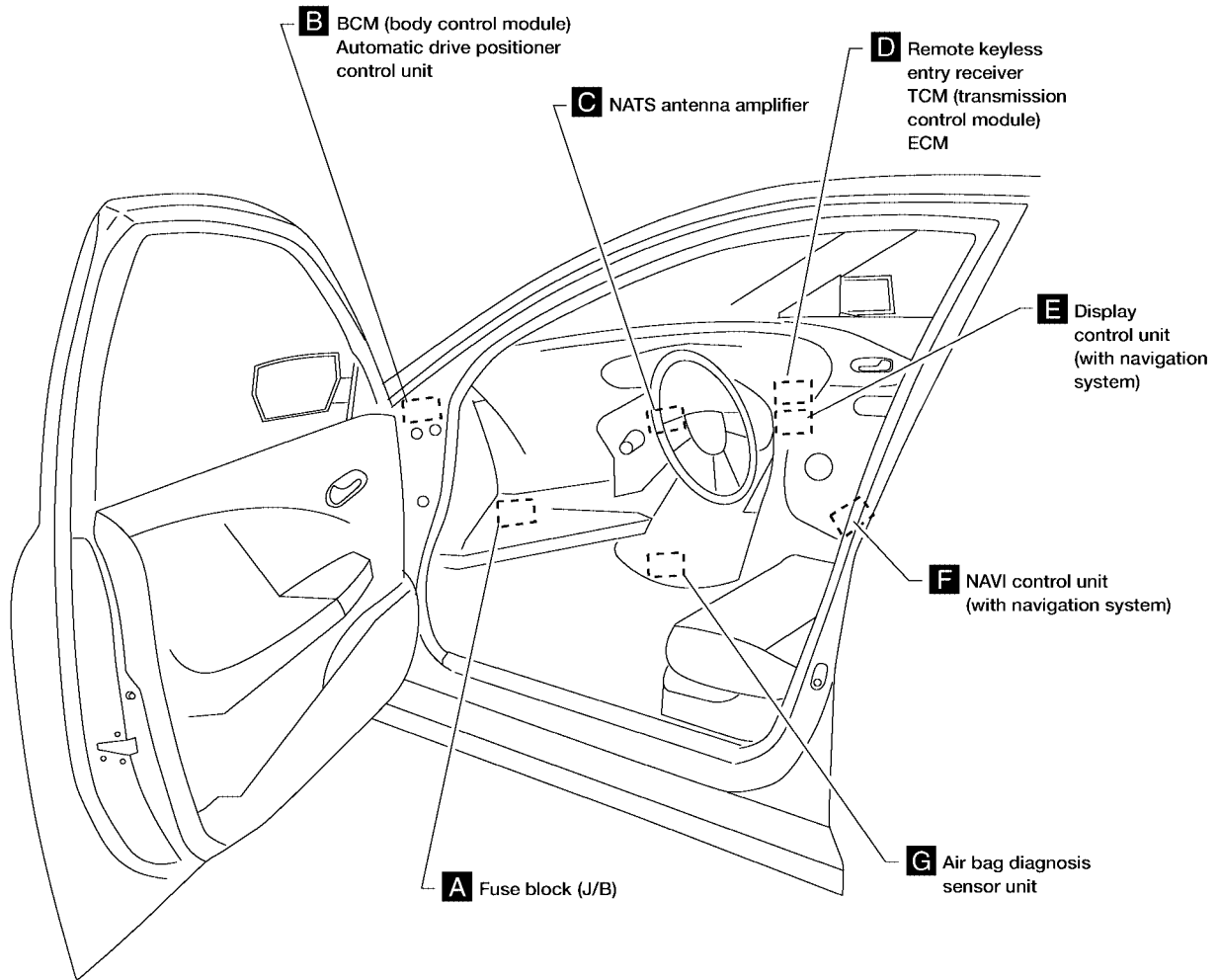

A Instrument panel side LH

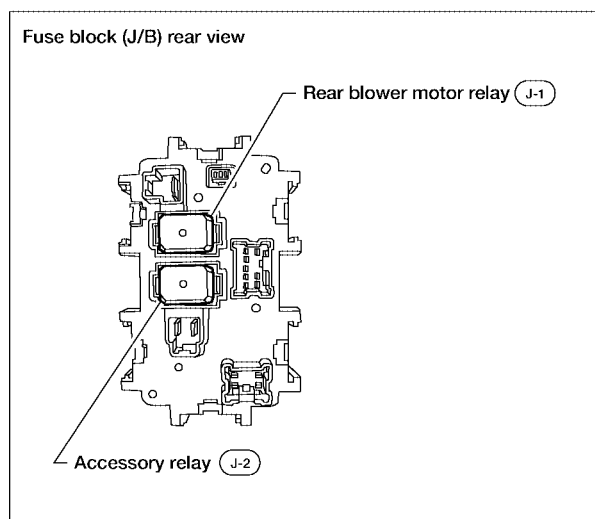
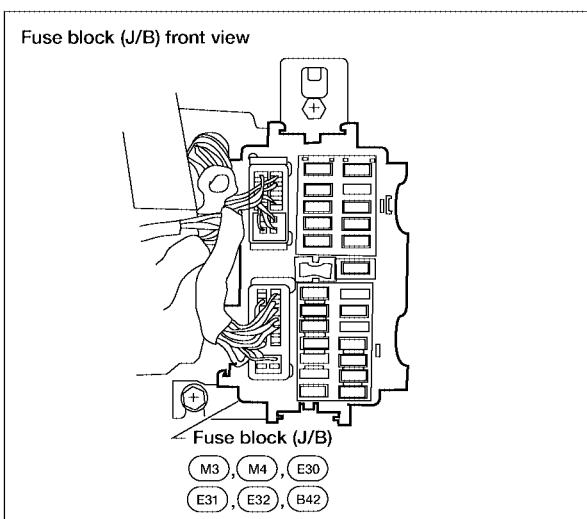

WKIA4818E

ELECTRICAL UNITS LOCATION

A
B
C
D
E
F
G
H
I
J
PG
L
M

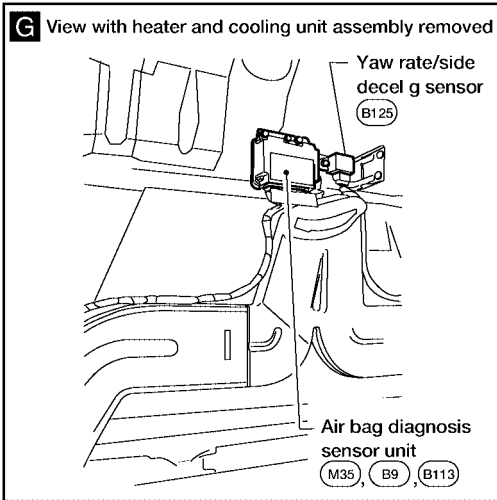
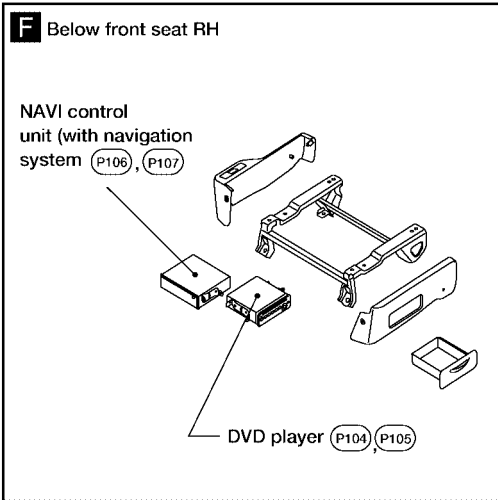
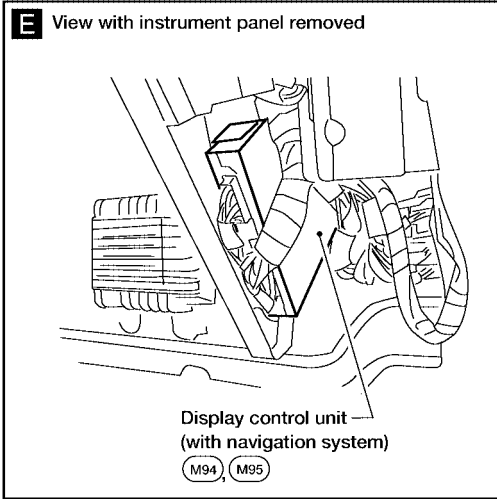
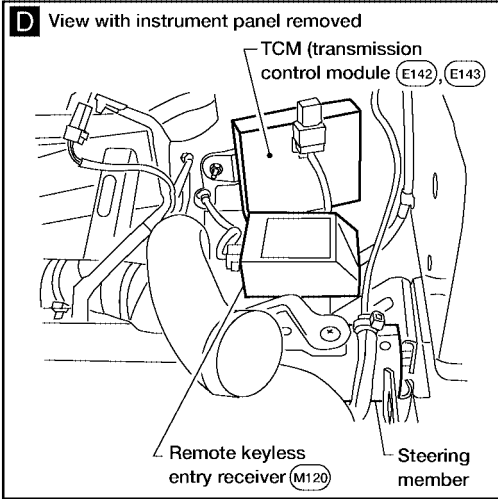
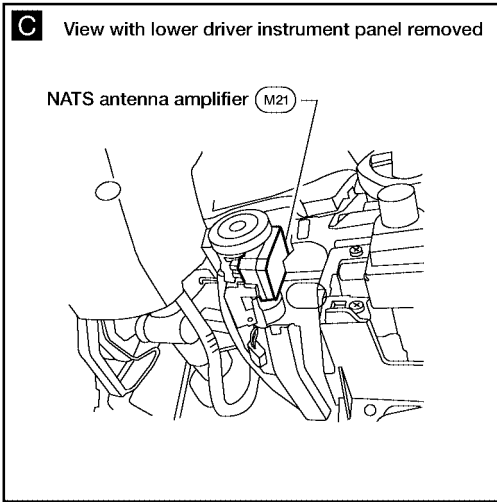
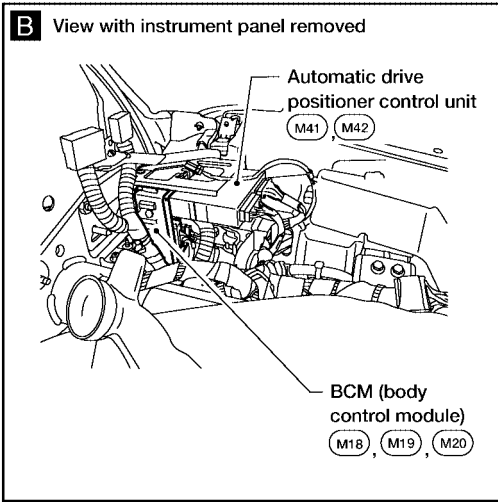

WKIA2935E

ELECTRICAL UNITS LOCATION

Fuse

EKS0064Q

- If fuse is blown, be sure to eliminate cause of incident before installing new fuse.
- Use fuse of specified rating. Never use fuse of more than specified rating.
- Do not partially install fuse; always insert it into fuse holder properly.
- Remove fuse for "ELECTRICAL PARTS (BAT)" if vehicle is not used for a long period of time.

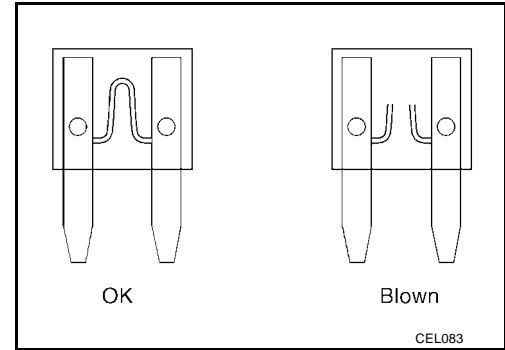

Fusible Link

EKS0064R

A melted fusible link can be detected either by visual inspection or by feeling with finger tip. If its condition is questionable, use circuit tester or test lamp.

CAUTION:

- If fusible link should melt, it is possible that critical circuit (power supply or large current carrying circuit) is shorted. In such a case, carefully check and eliminate cause of incident.
- Never wrap outside of fusible link with vinyl tape.
- Never let fusible link touch any other wiring harness, vinyl or rubber parts.

Circuit Breaker (Built Into BCM)

EKS0064S

For example, when current is 30A, the circuit is broken within 8 to 20 seconds.

A circuit breaker is used for the following systems:

- Power windows
- Power door locks
- Remote keyless entry system
- Power sunroof
- Rear window wiper

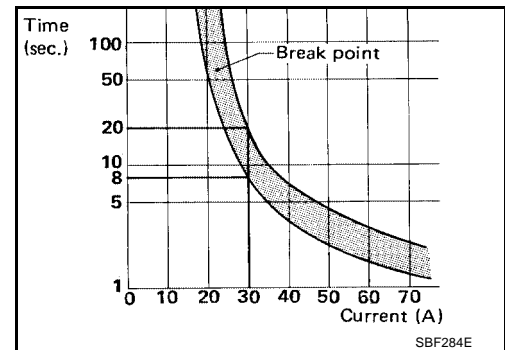

HARNESS CONNECTOR

PFP:B4341

EKS0064T

HARNESS CONNECTOR

Description

HARNESS CONNECTOR (TAB-LOCKING TYPE)

- The tab-locking type connectors help prevent accidental looseness or disconnection.
- The tab-locking type connectors are disconnected by pushing or lifting the locking tab(s). Refer to the illustration below.

Refer to the next page for description of the slide-locking type connector.

CAUTION:

Do not pull the harness or wires when disconnecting the connector.

[Example]

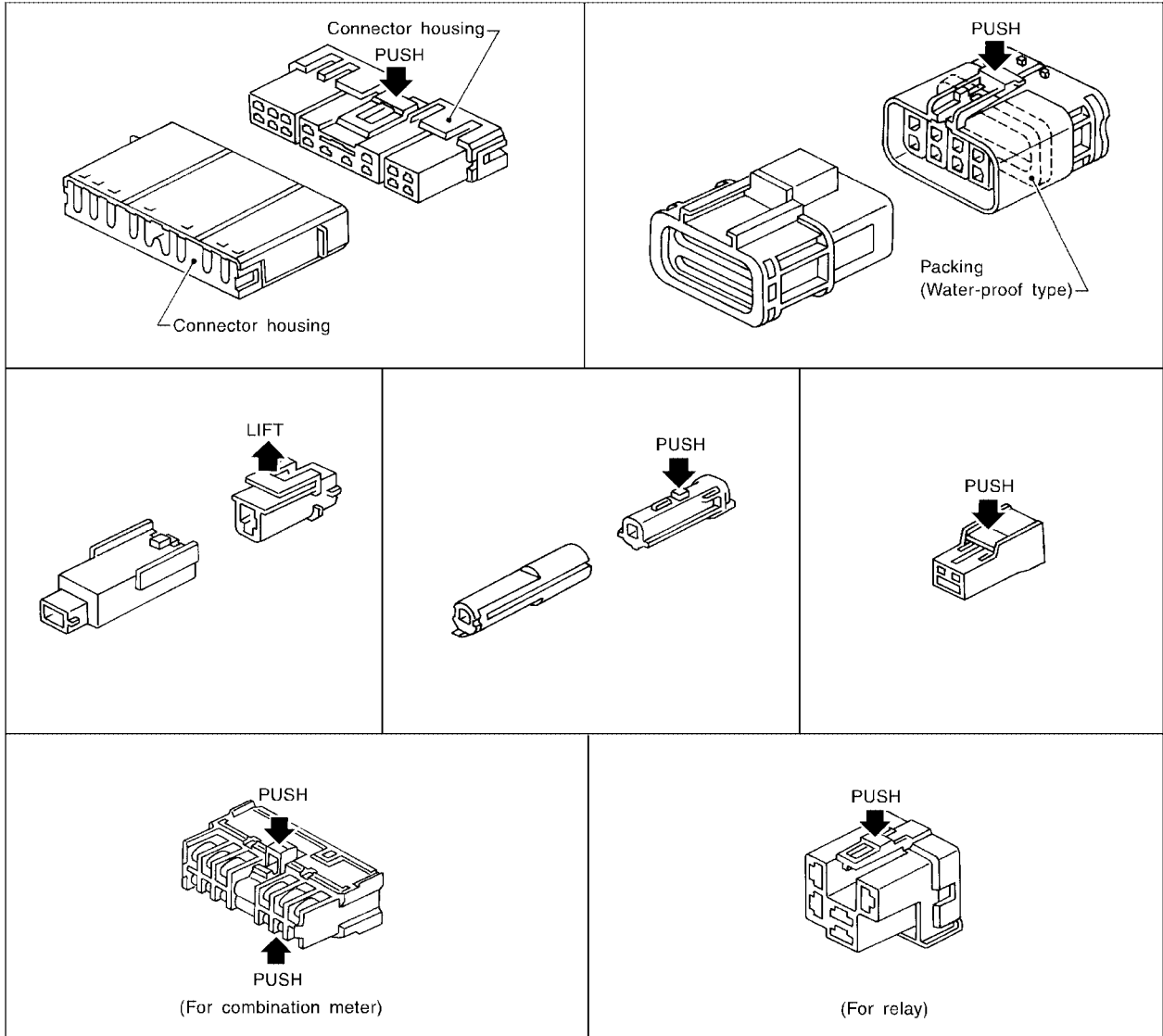

A
B
C
D
E
F
G
H
I
J
L
M

PG

HARNESS CONNECTOR

HARNESS CONNECTOR (SLIDE-LOCKING TYPE)

- A new style slide-locking type connector is used on certain systems and components, especially those related to OBD.
- The slide-locking type connectors help prevent incomplete locking and accidental looseness or disconnection.
- The slide-locking type connectors are disconnected by pushing or pulling the slider. Refer to the illustration below.

CAUTION:

- Do not pull the harness or wires when disconnecting the connector.
- Be careful not to damage the connector support bracket when disconnecting the connector.

[Example]

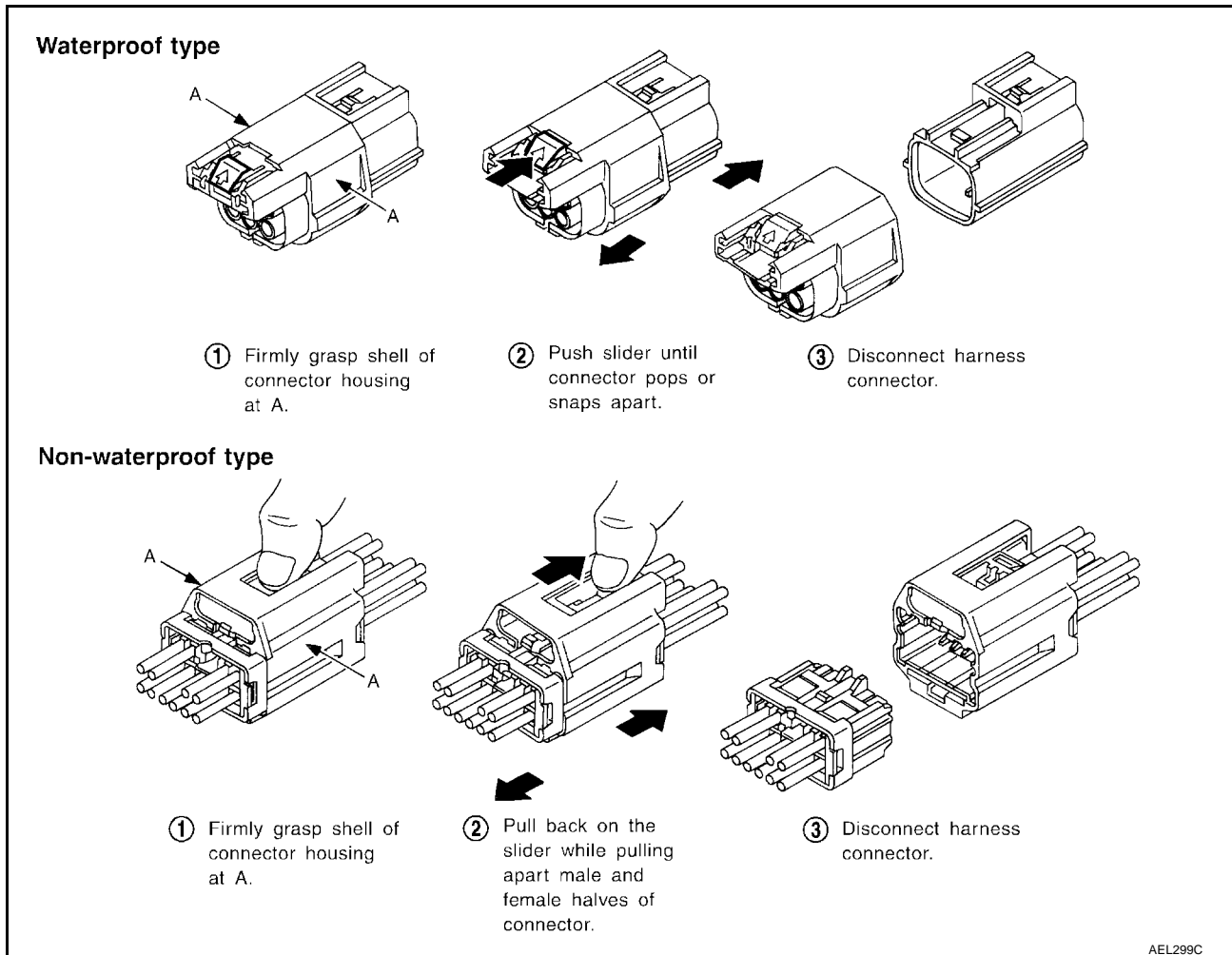

HARNES CONNECTOR

HARNES CONNECTOR (DIRECT-CONNECT SRS COMPONENT TYPE)

- SRS direct-connect type harness connectors are used on certain SRS components such as air bag modules and seat belt pre-tensioners.
- Always pull up to release black locking tab prior to removing connector from SRS component.
- Always push down to lock black locking tab after installing connector to SRS component. When locked, the black locking tab is level with the connector housing.

CAUTION:

- **Do not pull the harness or wires when removing connectors from SRS components.**

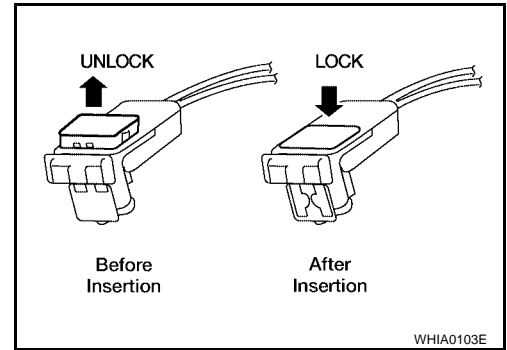

A
B
C
D
E
F
G
H
I
J
L
M

PG

ELECTRICAL UNITS

ELECTRICAL UNITS Terminal Arrangement

PFP:23710

EKS0064U

- : WITH VDC
- : EXCEPT VDC
- : WITH 4-SPEED A/T
- : WITH 5-SPEED A/T

BCM (BODY CONTROL MODULE)

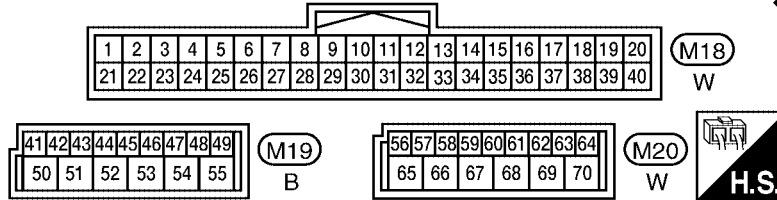

ABS ACTUATOR AND ELECTRIC UNIT (CONTROL UNIT)

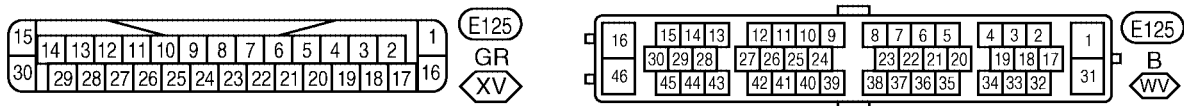

ECM

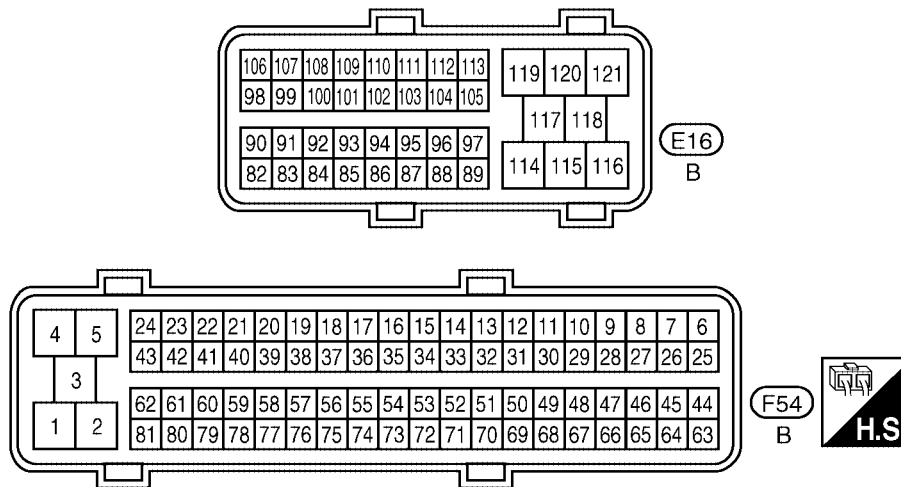

TCM (TRANSMISSION CONTROL MODULE)

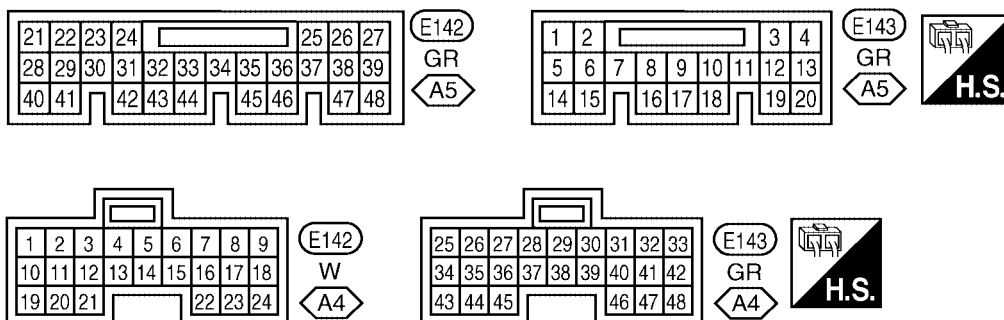

WKIA4819E

STANDARDIZED RELAY

PFP:25230

EKS0064V

STANDARDIZED RELAY

Description

NORMAL OPEN, NORMAL CLOSED AND MIXED TYPE RELAYS

Relays can mainly be divided into three types: normal open, normal closed and mixed type relays.

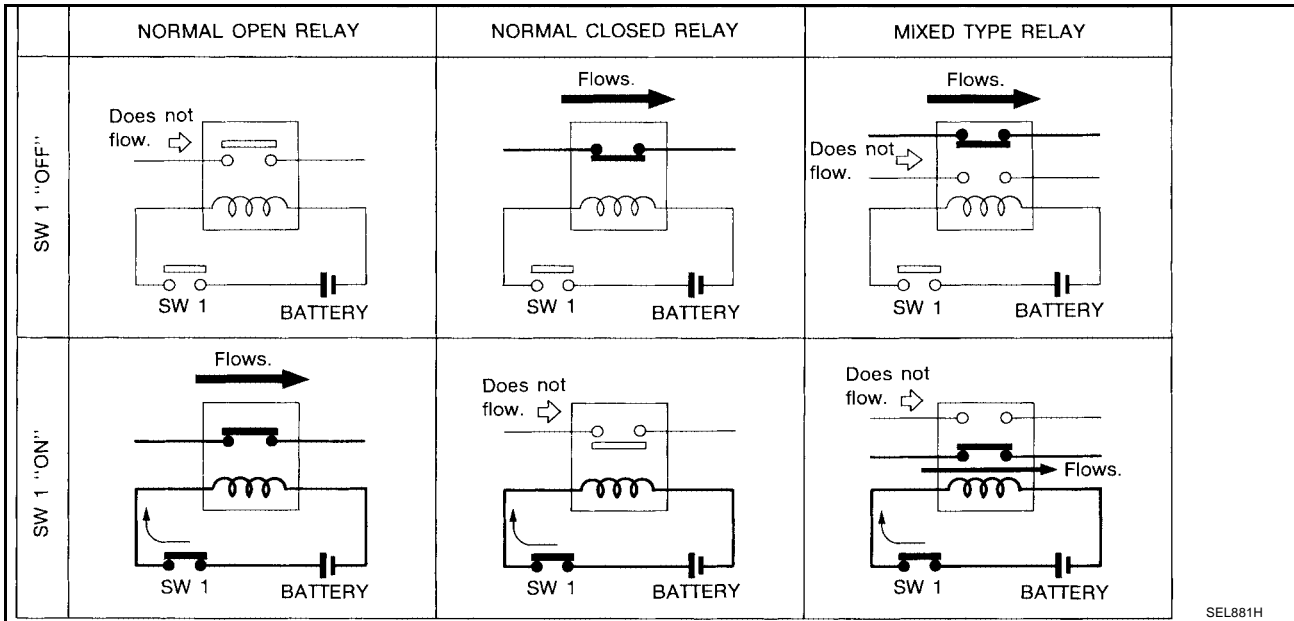

SEL881H

TYPE OF STANDARDIZED RELAYS

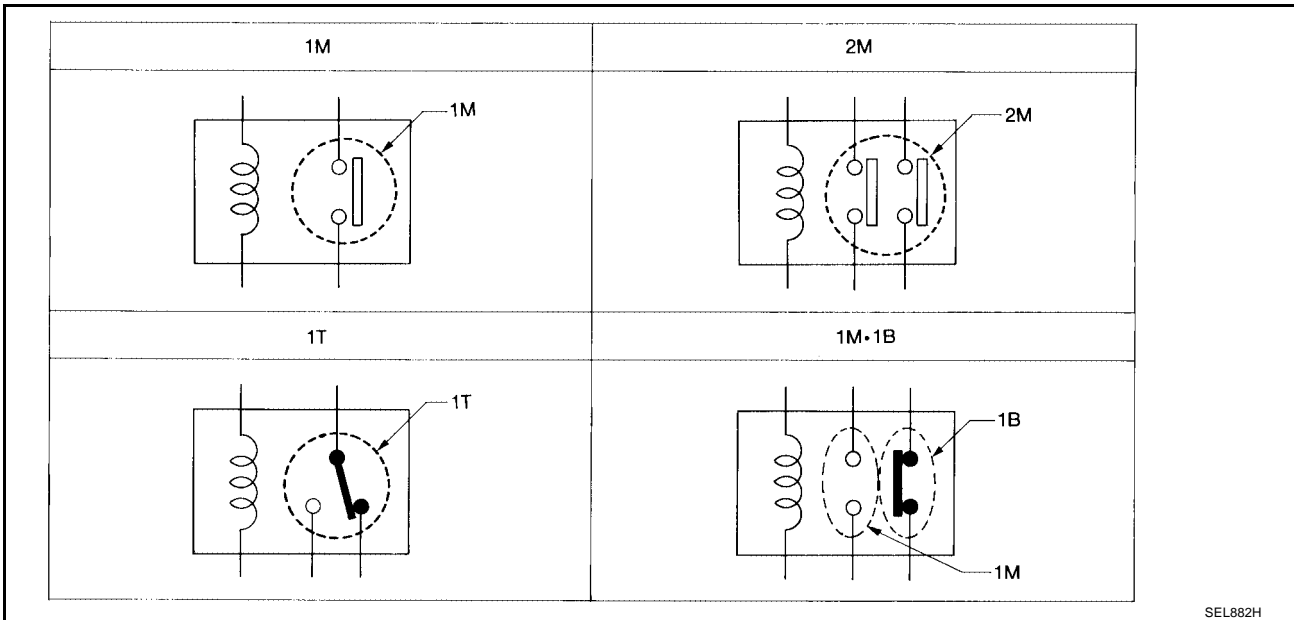

SEL882H

1M	1 Make	2M	2 Make
1T	1 Transfer	1M-1B	1 Make 1 Break

STANDARDIZED RELAY

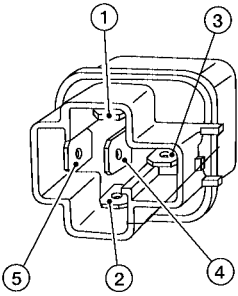
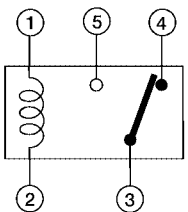
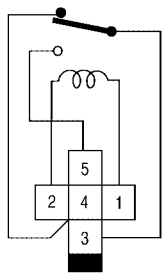
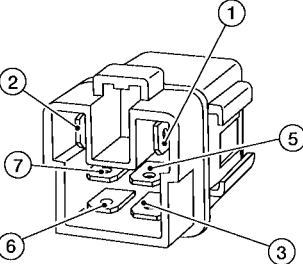
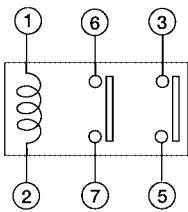
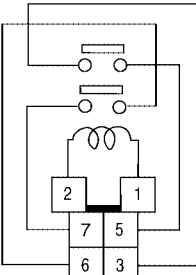
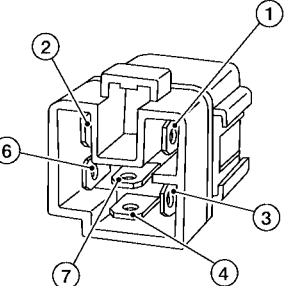
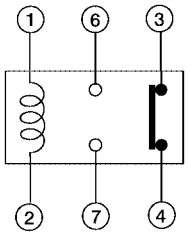
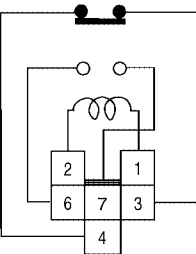
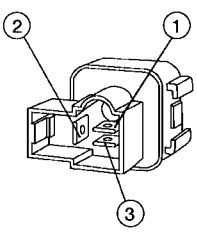
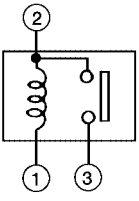
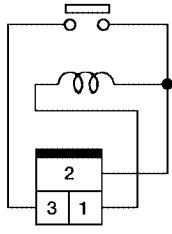
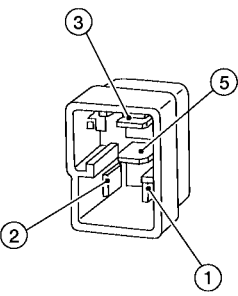
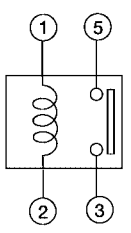
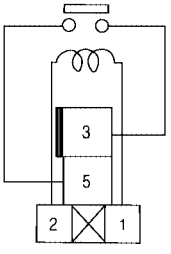
Type	Outer view	Circuit	Connector Symbol and connection	Case color
1T				BLACK
2M				BROWN
1M-1B				GRAY
1M				BLACK
				BLUE

The arrangement of terminal numbers on the actual relays may differ from those shown above.

WKIA0253E

SUPER MULTIPLE JUNCTION (SMJ)

SUPER MULTIPLE JUNCTION (SMJ)

PF:84341

Terminal Arrangement

EKS006FA

A
B
C
D
E
F
G
H
I
J
PG
L
M

FRONT SEAT HARNESS RH

P102

24A	23A	22A	21A	20A	19A	18A	17A	16A	15A	14A	13A	12A	11A	10A	9A	8A	7A	6A	5A	4A	3A	2A	1A
24B	23B	22B	21B	20B	19B	18B	17B	16B	15B	14B	13B	12B	11B	10B	9B	8B	7B	6B	5B	4B	3B	2B	1B



B116

24B	23B	22B	21B	20B	19B	18B	17B	16B	15B	14B	13B	12B	11B	10B	9B	8B	7B	6B	5B	4B	3B	2B	1B
24A	23A	22A	21A	20A	19A	18A	17A	16A	15A	14A	13A	12A	11A	10A	9A	8A	7A	6A	5A	4A	3A	2A	1A

BODY NO.2 HARNESS

LKIA0358E

FUSE BLOCK-JUNCTION BOX (J/B)

PF0:24350

EKS0064W

FUSE BLOCK-JUNCTION BOX (J/B)

Terminal Arrangement

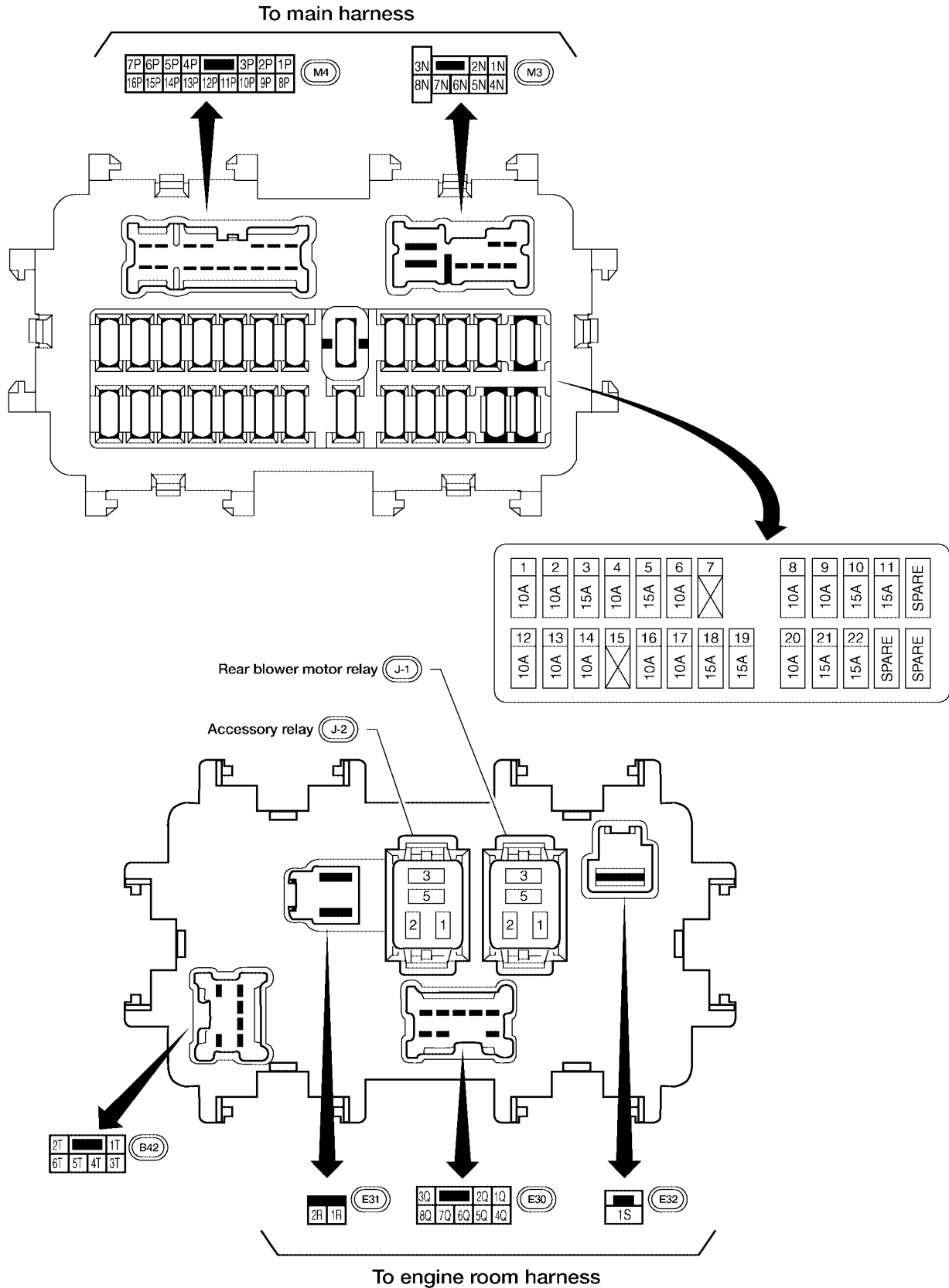

WKIA4820E

FUSE AND FUSIBLE LINK BOX

FUSE AND FUSIBLE LINK BOX

PFP:24381

Terminal Arrangement

EKS0064X

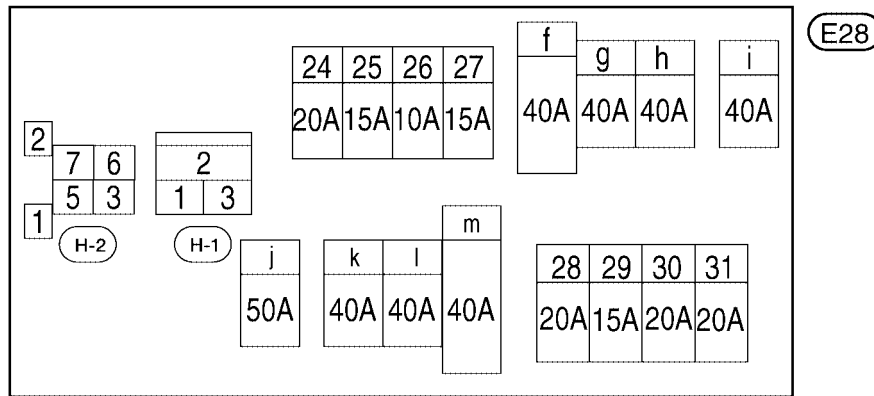

24 - 31: FUSE f - m: FUSIBLE LINK

A
B
C
D
E
F
G
H
I
J
L
M

PG

FUSE AND FUSIBLE LINK BOX
