

ACCELERATOR CONTROL, FUEL & EXHAUST SYSTEMS

GI

MA

EM

LC

EC

FE

SECTION FE

CONTENTS

PREPARATION	2	FUEL SYSTEM	4	AT
Special Service Tool	2	Removal and Installation	4	
Commercial Service Tool	2	FUEL TANK	5	AX
ACCELERATOR CONTROL SYSTEM	3	FUEL PUMP AND GAUGE	6	
Removal and Installation	3	EXHAUST SYSTEM	8	SU
Adjusting Accelerator Wire	3	Removal and Installation	8	

BR

ST

RS

BT

HA

SC

EL

IDX

PREPARATION

Special Service Tool

Special Service Tool

NDFE0001

The actual shapes of Kent-Moore tools may differ from those of special service tools illustrated here.

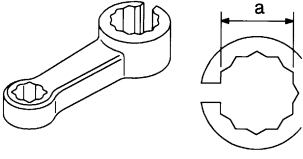
Tool number (Kent-Moore No.) Tool name	Description
KV10114400 (J38365) Heated oxygen sensor wrench	 <p data-bbox="1031 352 1442 430">Loosening or tightening rear heated oxygen sensor a: 22 mm (0.87 in)</p> <p data-bbox="402 525 462 546">NT636</p>

Commercial Service Tool

NDFE0006

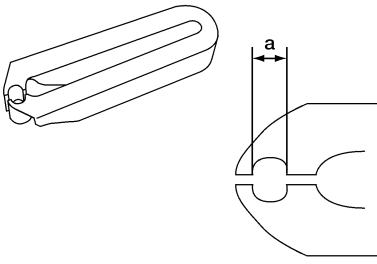
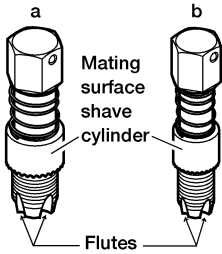
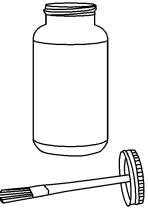
Tool number (Kent-Moore No.) Tool name	Description
Fuel tube removal tool	 <p data-bbox="1031 735 1453 814">For disconnecting fuel tube quick connectors a: 7.9 mm (5/16 in)</p> <p data-bbox="402 1060 470 1081">AFE111</p>
(J-43897-18) (J-43897-12) Oxygen Sensor Thread Cleaner	 <p data-bbox="1031 1096 1469 1285">Reconditioning the exhaust system threads before installing a new oxygen sensor. Use with anti-seize lubricant shown below a: J-43897-18 18mm diameter, for Zirconia oxygen sensor a: J-43897-12 12mm diameter, for Titania oxygen sensor</p> <p data-bbox="402 1375 479 1396">AEM488</p>
Anti-seize lubricant (Permatex [™] 133AR or equivalent meeting MIL specification MIL-A-907)	 <p data-bbox="1031 1411 1458 1486">Lubricating oxygen sensor thread cleaning tool when reconditioning exhaust system threads</p> <p data-bbox="402 1690 479 1711">AEM489</p>

ACCELERATOR CONTROL SYSTEM

Removal and Installation

Removal and Installation

NDFE0002

CAUTION:

- When removing accelerator wire, make a mark to indicate lock nut's initial position.
- Check that throttle valve opens fully when accelerator pedal is fully depressed. Also check that it returns to idle position when pedal is released.
- Check accelerator control parts for improper contact with any adjacent parts.
- When connecting accelerator wire, be careful not to twist or scratch its inner wire.
- For ASCD wire adjustment refer to *EL-236*, "ASCDC Wire Adjustment".

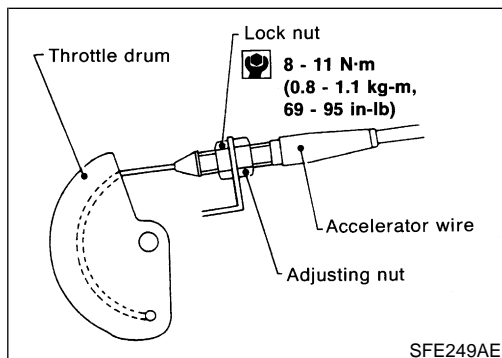
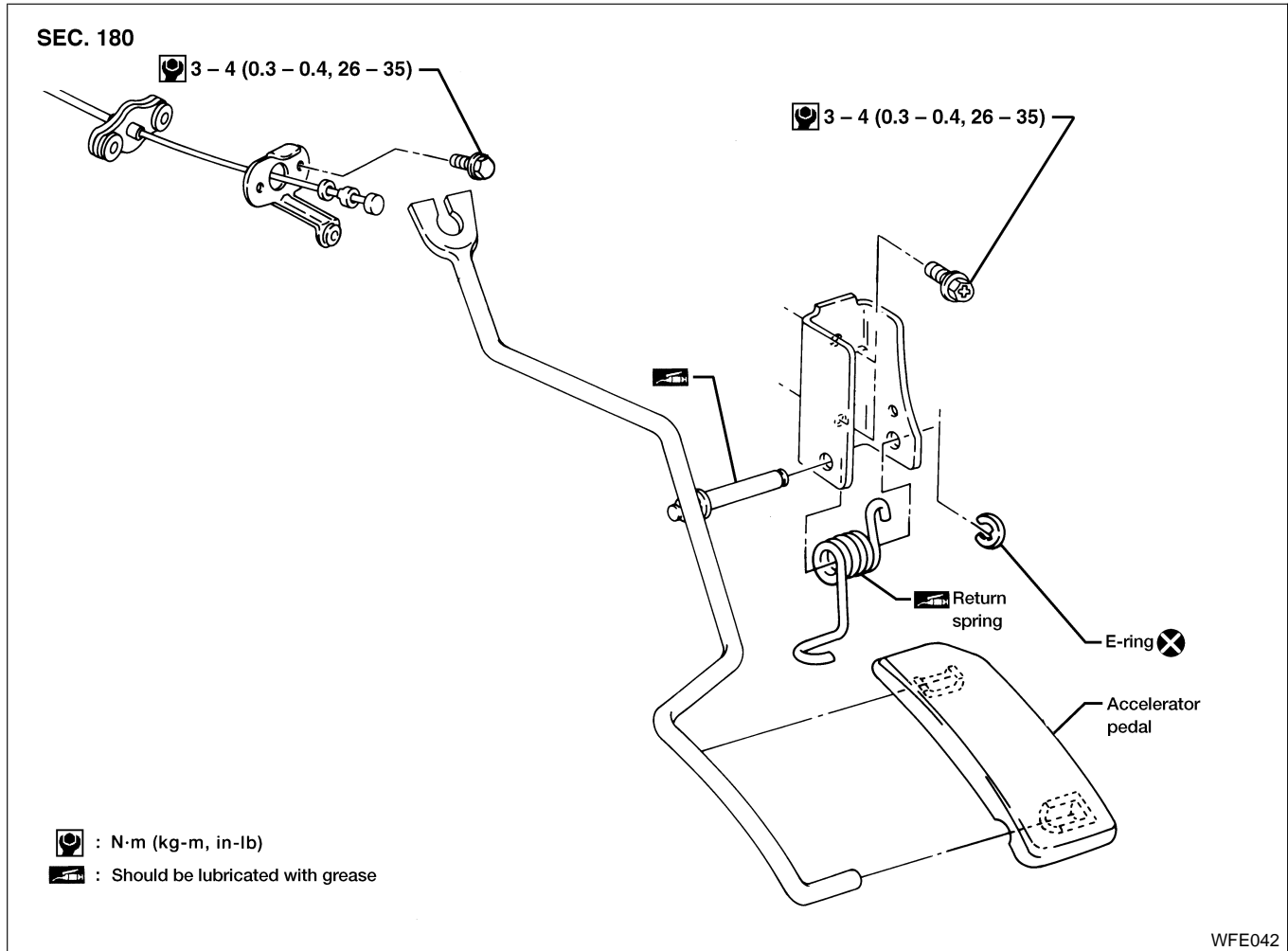

Adjusting Accelerator Wire

NDFE0003

NOTE:

Adjust accelerator wire with the engine warmed up to normal operating temperature and ignition switch turned to OFF.

1. Loosen lock nut, and tighten adjusting nut until throttle drum starts to move.
2. From that position turn back adjusting nut 1.5 to 2 turns, and secure lock nut.

GI

MA

EM

LC

EC

FE

AT

AX

SU

BR

ST

RS

BT

HA

SC

EL

IDX

Removal and Installation

NDFE0004

WARNING:

When replacing fuel line parts, be sure to observe the following:

- Put a “CAUTION: INFLAMMABLE” sign in workshop.
- Do not smoke while servicing fuel system. Keep open flames and sparks away from work area.
- Be sure to furnish the workshop with a CO₂ fire extinguisher.

CAUTION:

- Before removing fuel line parts, carry out the following procedures:
 - a) Put drained fuel in an explosion-proof container and put lid on securely.
 - b) Release fuel pressure from fuel line. Refer to *MA-19*, “Changing Fuel Filter”.
 - c) Disconnect battery ground cable.
 - Remove quick connectors with Commercial Service Tool.
 - Always replace O-ring with a new one.
 - Do not kink or twist hoses and tubes when installed.
 - Do not tighten hose clamps excessively to avoid damaging hoses.
- When installing fuel check valve, be careful of its designated direction. Refer to *EC-28*, “EVAPORATIVE EMISSION SYSTEM”.
- After installation, run engine and check for fuel leaks at connections.

FUEL SYSTEM

Removal and Installation (Cont'd)

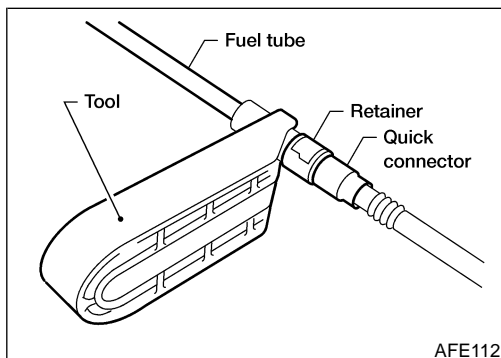
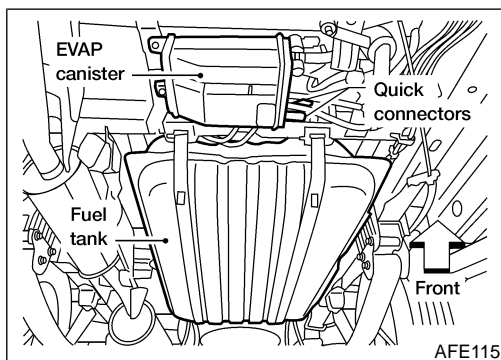
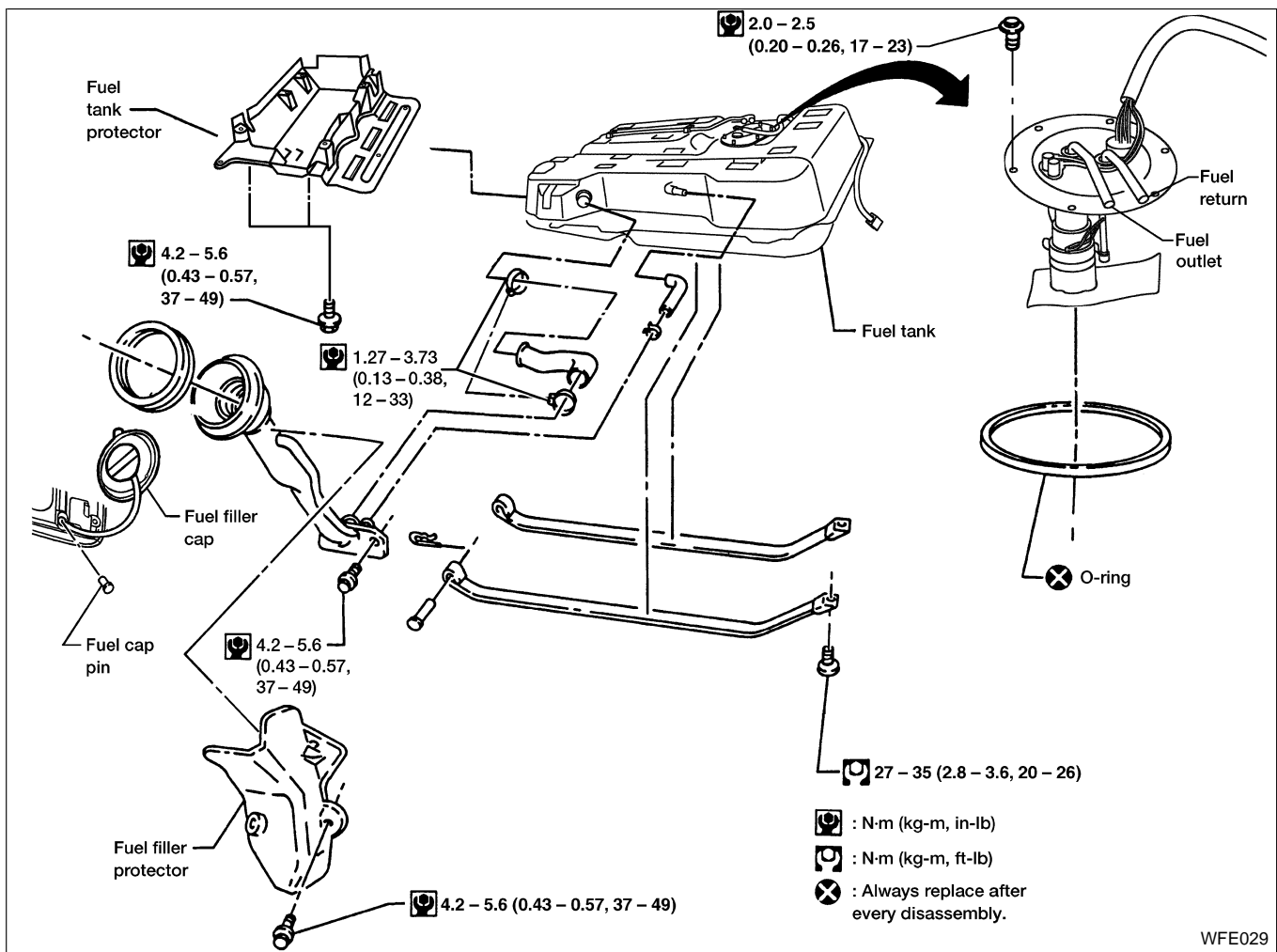

FUEL TANK

NDFE0004S01

1. Release fuel pressure from fuel line. Refer to **MA-19**, "Changing Fuel Filter".
2. Disconnect battery ground cable.
3. Drain fuel from fuel tank.
4. Disconnect electrical connectors.
5. Remove filler protector.
6. Disconnect filler tube.

7. Disconnect the quick connectors as follows.

CAUTION:

- To prevent damaging fuel lines, remove quick connectors with Tool.
- Keep the connecting portion of the tubes and quick connector clean.

- 1) Put mating marks on tubes and connectors for correct installation.
- 2) Hold side of connector, slide tool inside of quick connector to open retainer and pull tube out of quick connector.

GI

MA

EM

LC

EC

FE

AT

AX

SU

BR

ST

RS

BT

HA

SC

EL

IDX

FUEL SYSTEM

Removal and Installation (Cont'd)

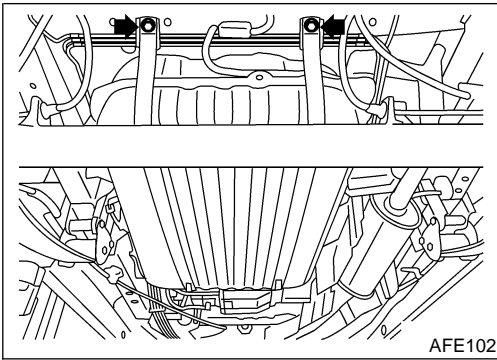

8. Remove tank mounting band bolts while supporting fuel tank.

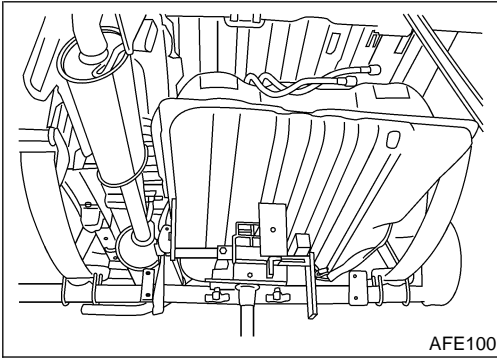

9. Remove fuel tank.

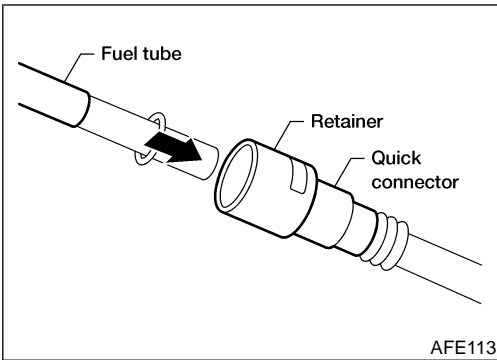

To install, reverse the removal procedure. Connect the quick connectors as follows.

- Be sure that the connecting portion is clean and smooth.
- Align mating marks.
- Insert tube into the center of the connector until you hear a click.

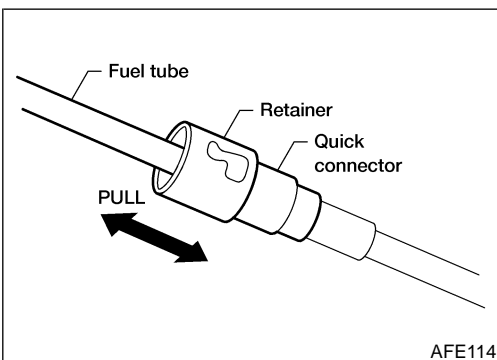

After connecting quick connectors, make sure the connection is firmly made using the following method.

- Pull on the fuel tube and connector to make sure they are firmly connected.
- Start the engine, increase engine speed and verify that there are no leaks.

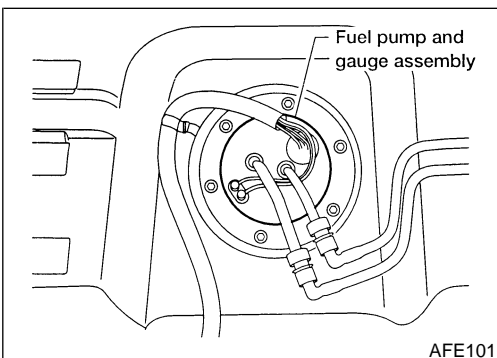

FUEL PUMP AND GAUGE

NDFE0004S02

1. Remove fuel tank. Refer to "FUEL TANK", FE-5.
 - For removal of quick connectors, refer to step 7 of "FUEL TANK", FE-5.
2. Disconnect battery ground cable.
3. Disconnect fuel tubes and electrical connectors.
4. Remove the six bolts.

FUEL SYSTEM

Removal and Installation (Cont'd)

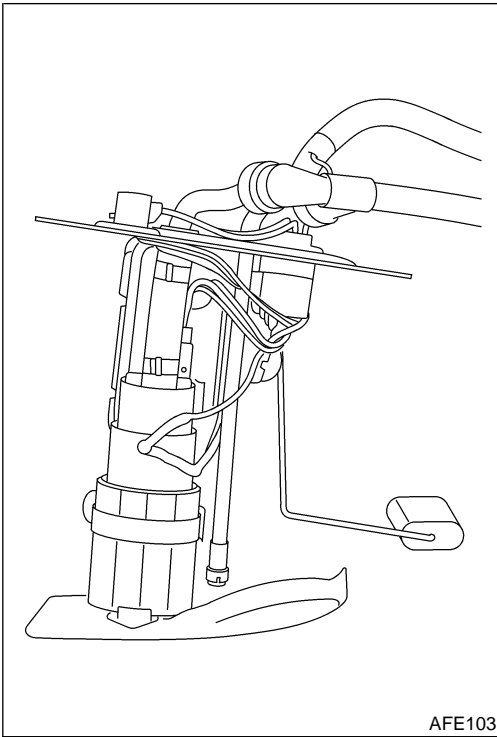

5. Remove fuel gauge assembly.

Installation procedure is the reverse order of removal.

CAUTION:

- Tighten bolts to specified torque.
 - ☑ : 2.0 - 2.5 N-m (0.20 - 0.26 kg-m, 17.4 - 22.6 in-lb)
- Always replace O-ring with a new one.
- After installation, run engine and check for leaks at connectors.

GI

MA

EM

LC

EC

FE

AT

AX

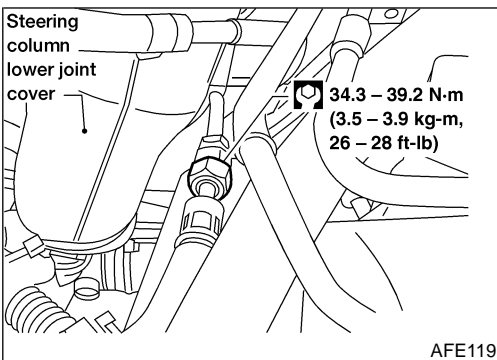

CAUTION:

Do not overtighten the flare nut, otherwise it may damage the seating surface.

SU

BR

ST

RS

BT

HA

SC

EL

IDX

EXHAUST SYSTEM

Removal and Installation

Removal and Installation

NDFE0005

CAUTION:

- Always replace exhaust gaskets with new ones when reassembling.
- With engine running, check all tube connections for exhaust gas leaks, and entire system for unusual noises.
- Check to ensure that mounting brackets and mounting insulators are installed properly and free from undue stress. Improper installation could result in excessive noise or vibration.
- Discard any heated oxygen sensor which has been dropped from a height of more than 0.5 m (19.7 in) onto a hard surface such as a concrete floor; use a new one.
- Before installing new heated oxygen sensor, clean exhaust system threads using Oxygen Sensor Thread Cleaner tool J-43897-18 or J-43897-12 and approved anti-seize lubricant.
- Do not overtorque the heated oxygen sensor. Doing so may cause damage to the heated oxygen sensor, resulting in the MIL coming on.

EXHAUST SYSTEM

Removal and Installation (Cont'd)

SEC. 200

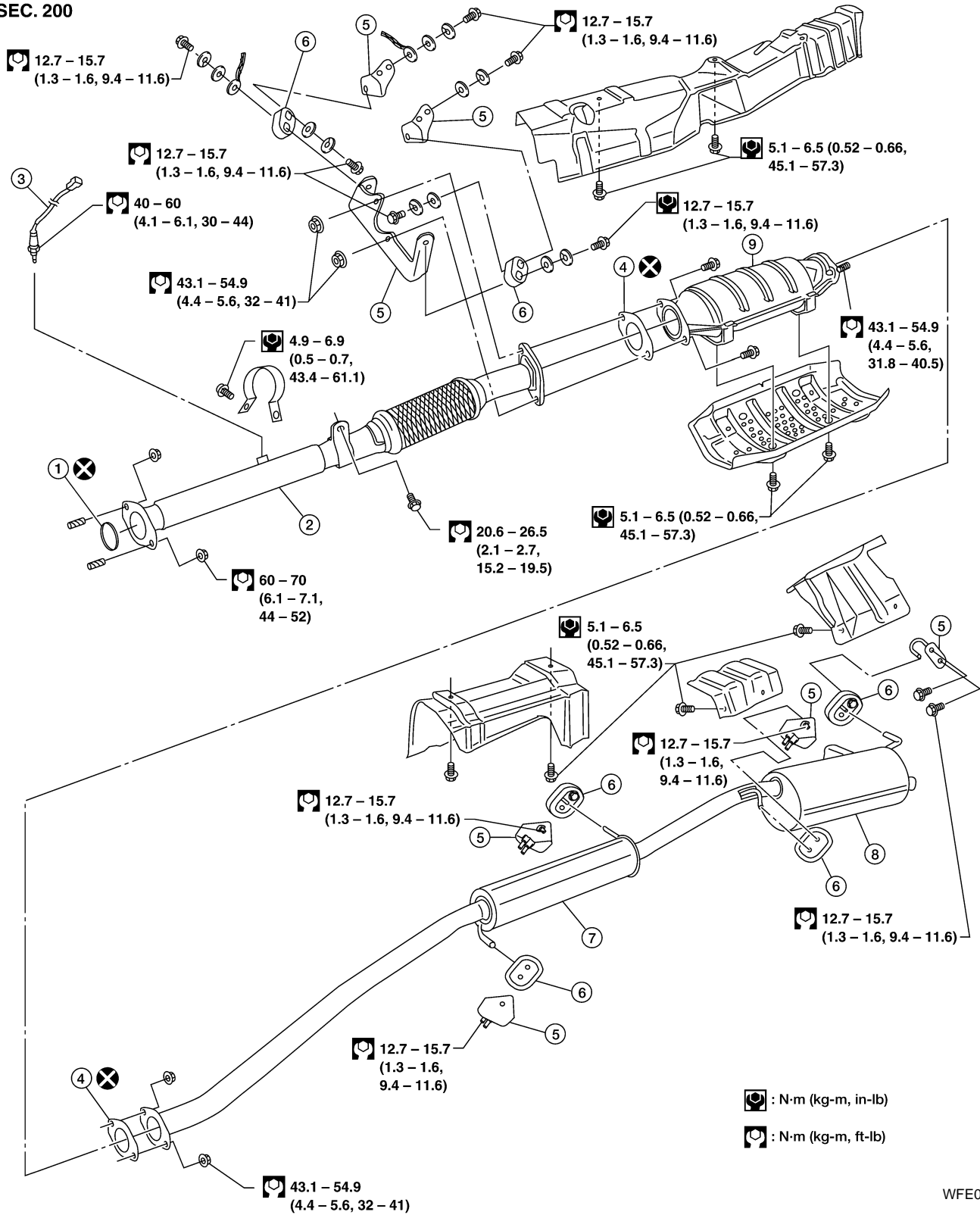

- 1. Gasket
- 2. Front tube
- 3. Heated oxygen sensor 2 (Rear)

- 4. Gasket
- 5. Mounting bracket
- 6. Mounting rubber

- 7. Center muffler
- 8. Rear muffler
- 9. Three way catalyst (under floor)

GI

MA

EM

LC

EC

FE

AT

AX

SU

BR

ST

RS

BT

HA

SC

EL

IDX

NOTES