

ENGINE LUBRICATION & COOLING SYSTEMS

GI

MA

EM

LC

EC

FE

AT

AX

SU

BR

ST

RS

BT

HA

SC

EL

IDX

SECTION **LC**

CONTENTS

ENGINE LUBRICATION SYSTEM	2	Cooling Circuit	8
Precautions	2	System Check.....	8
LIQUID GASKET APPLICATION PROCEDURE.....	2	CHECKING COOLING SYSTEM HOSES.....	8
Preparation	2	CHECKING RADIATOR CAP.....	8
SPECIAL SERVICE TOOLS	2	CHECKING COOLING SYSTEM FOR LEAKS.....	9
Lubrication Circuit.....	3	Water Pump.....	9
Oil Pressure Check.....	3	REMOVAL.....	9
Oil Pump.....	4	INSPECTION.....	10
REMOVAL AND INSTALLATION.....	4	INSTALLATION.....	10
DISASSEMBLY AND ASSEMBLY.....	4	Thermostat.....	11
INSPECTION.....	5	REMOVAL.....	11
REGULATOR VALVE INSPECTION	5	INSPECTION.....	11
OIL FILTER	6	INSTALLATION.....	12
Service Data and Specifications (SDS).....	6	Radiator	12
OIL PRESSURE	6	REMOVAL AND INSTALLATION.....	12
REGULATOR VALVE	6	INSPECTION.....	13
OIL PUMP.....	6	Refilling Engine Coolant	14
ENGINE COOLING SYSTEM	7	Overheating Cause Analysis	14
Precautions	7	Cooling Fan Control System	15
LIQUID GASKET APPLICATION PROCEDURE.....	7	Service Data and Specifications (SDS).....	15
Preparation	7	THERMOSTAT	15
SPECIAL SERVICE TOOLS	7	RADIATOR.....	16

ENGINE LUBRICATION SYSTEM

Precautions

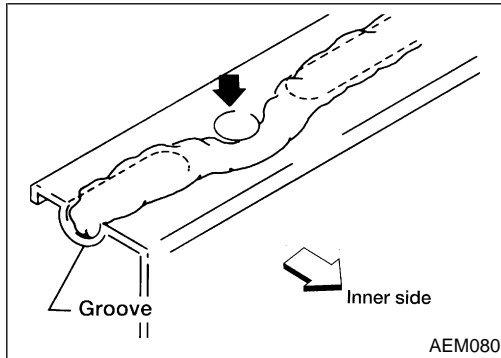
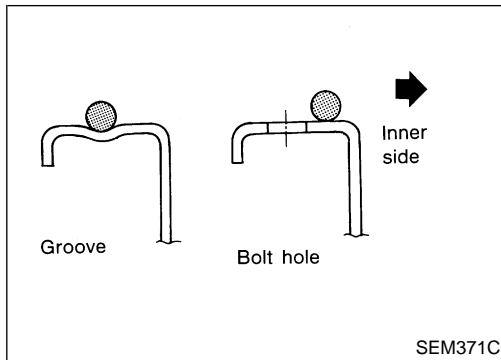

Precautions

LIQUID GASKET APPLICATION PROCEDURE

NDLC0001

1. Use a scraper to remove all traces of old liquid gasket from mating surface and grooves. Also, completely clean any oil from these areas.
2. Apply a continuous bead of liquid gasket to mating surfaces. (Use Genuine RTV Silicone Sealant Part No. 999MP-A7007 or equivalent.)
 - Be sure liquid gasket is 3.5 to 4.5 mm (0.138 to 0.177 in) dia. (for oil pan).
 - Be sure liquid gasket is 2.0 to 3.0 mm (0.079 to 0.118 in) dia. (in areas except oil pan).
3. Apply liquid gasket around the inner side of bolt holes (unless otherwise specified).
4. Assembly should be done within 5 minutes after coating.
5. Wait at least 30 minutes before refilling engine oil and engine coolant.

Preparation

SPECIAL SERVICE TOOLS

NDLC0002

The actual shapes of Kent-Moore tools may differ from those of special service tools illustrated here.

Tool number (Kent-Moore No.) Tool name	Description
ST25051001 (J25695-1) Oil pressure gauge	<p>PF1/4x19/in</p> <p>Measuring oil pressure Maximum measuring range: 2,452 kPa (25 kg/cm², 356 psi)</p> <p>NT558</p>
ST25052000 (J25695-2) Hose	<p>PS1/4x19/in PS1/8x28/in</p> <p>Adapting oil pressure gauge to cylinder block</p> <p>NT559</p>
KV10115801 (J38956) Oil filter wrench	<p>14 faces, Inner span: 64.3 mm (2.531 in) (Face to opposite face)</p> <p>Removing oil filter</p> <p>NT362</p>
WS39930000 () Tube presser	<p>Pressing the tube of liquid gasket</p> <p>NT052</p>

NDLC0003

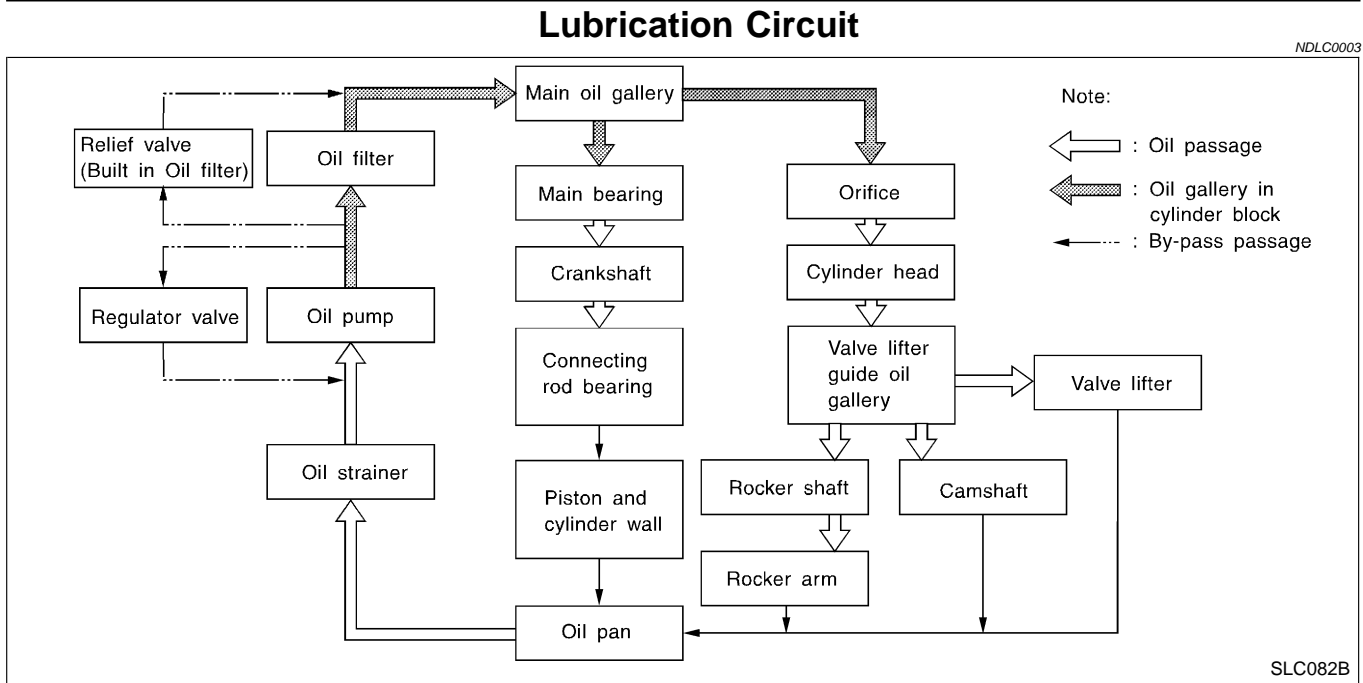

GI

MA

EM

LC

EC

FE

AT

AX

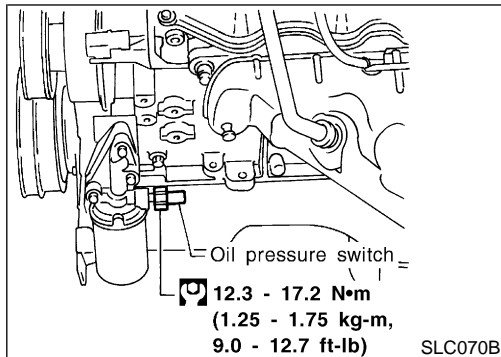

Oil Pressure Check

NDLC0004

WARNING:

- Be careful not to burn yourself, as the engine and oil may be hot.

- Put selector lever in Park P position.

1. Check oil level.
2. Remove oil pressure switch.

3. Install pressure gauge.
4. Start engine and warm it up to normal operating temperature.
5. Check oil pressure with engine running under no-load.

Engine speed rpm	Approximate discharge pressure kPa (kg/cm ² , psi)
Idle speed	More than 59 (0.6, 9)
2,000	412 - 451 (4.2 - 4.6, 60 - 65)

If difference is extreme, check oil passage and oil pump for oil leaks.

6. Install oil pressure switch with sealant.

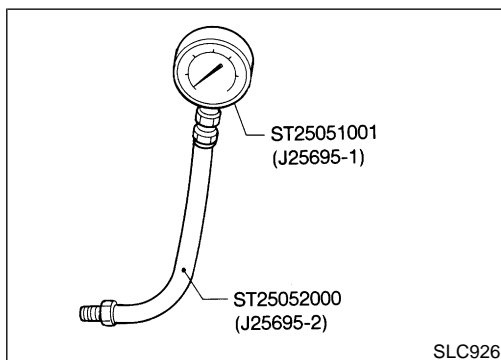

ST

RS

BT

HA

SC

EL

IDX

ENGINE LUBRICATION SYSTEM

Oil Pump

REMOVAL AND INSTALLATION

NDLC0005

1. Drain engine oil.
2. Remove oil pan. Refer to **EM-14**, "Removal".
3. After removing oil pan, install center member assembly and engine mounting insulator bolts and nuts.
4. Remove timing belt. Refer to **EM-18**, "Removal".
5. Remove timing belt tensioner.
6. Remove crankshaft sprocket and timing belt plate.
7. Remove oil pump assembly and gasket.

DISASSEMBLY AND ASSEMBLY

NDLC0006

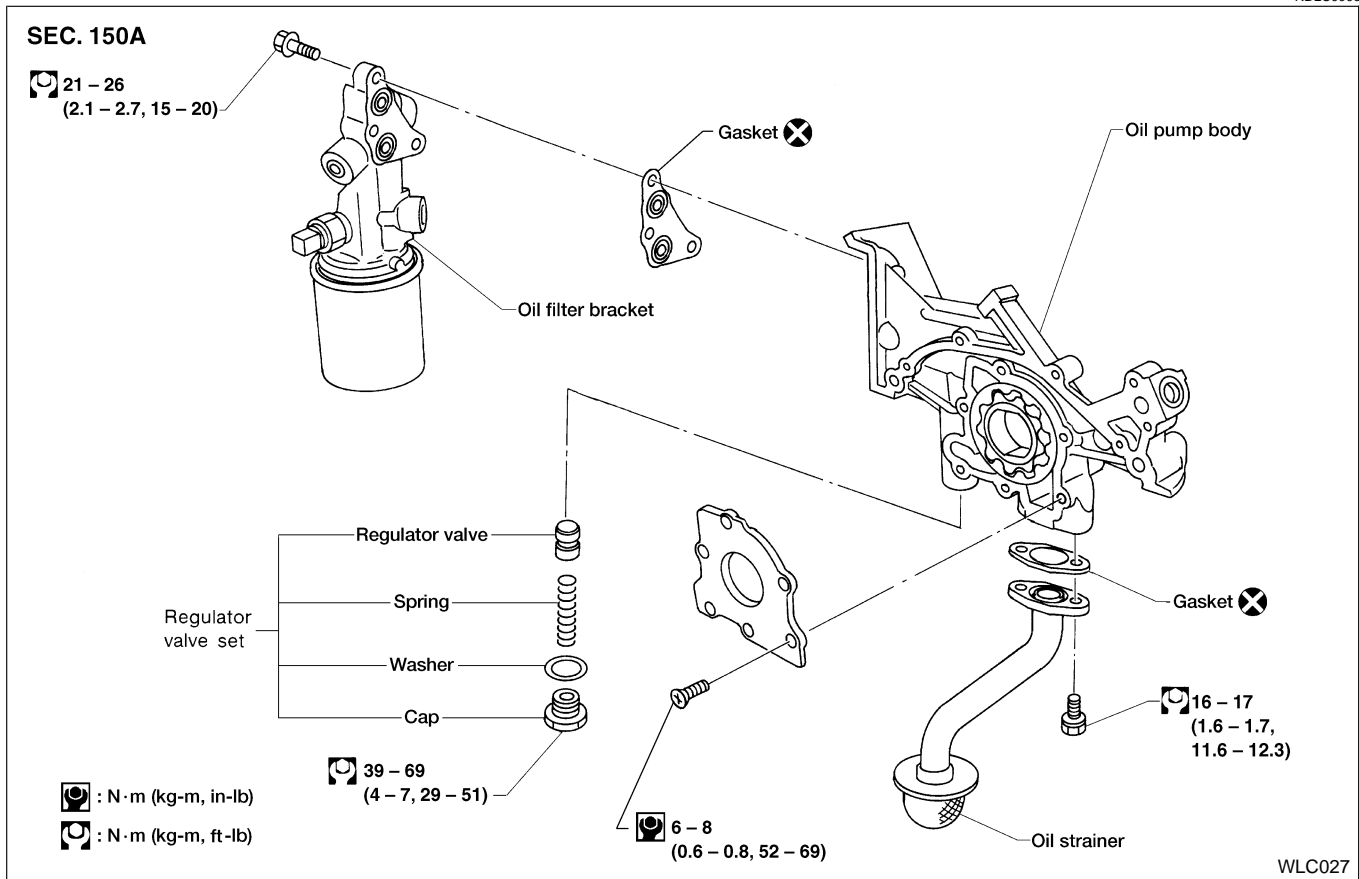

- Always replace with new oil seal and gasket.
- When installing oil pump, apply engine oil to inner and outer gears.

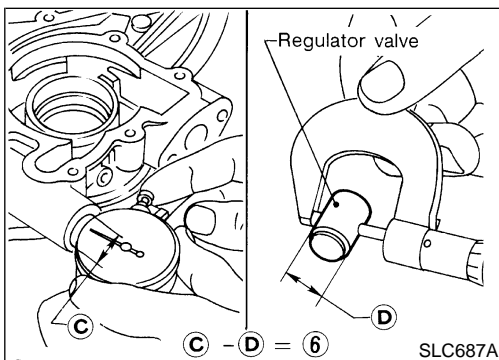
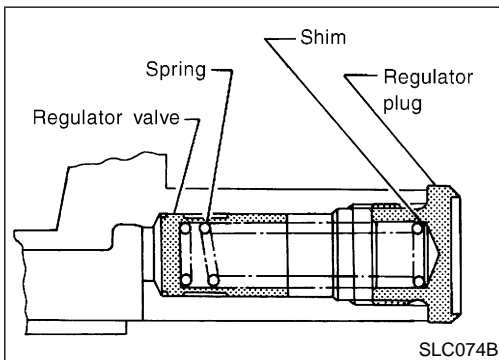
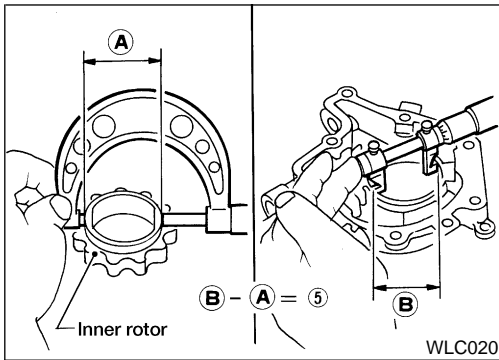
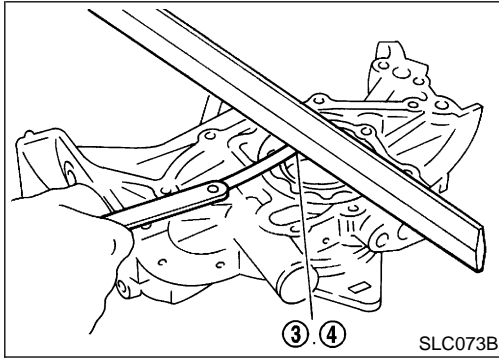
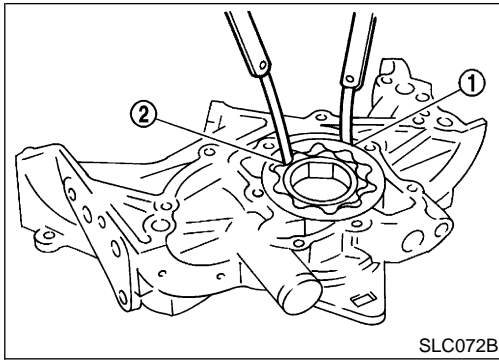

INSPECTION

NDLC0007

Using a feeler gauge, straightedge and micrometers, check the following clearances:

Unit: mm (in)

Body to outer rotor radial clearance 1	0.114 - 0.200 (0.0045 - 0.0079)
Inner rotor to outer rotor tip clearance 2	Below 0.18 (0.0071)
Body to inner rotor axial clearance 3	0.05 - 0.09 (0.0020 - 0.0035)
Body to outer rotor axial clearance 4	0.050 - 0.110 (0.0020 - 0.0043)
Inner rotor to brazed portion of housing clearance 5	0.045 - 0.091 (0.0018 - 0.0036)

- If the tip clearance (2) exceeds the limit, replace rotor set.
- If body to rotor clearances (1, 3, 4, 5) exceed the limit, replace oil pump body assembly.

REGULATOR VALVE INSPECTION

NDLC0008

1. Visually inspect components for wear and damage.
2. Check oil pressure regulator valve sliding surface and valve spring.
3. Coat regulator valve with engine oil. Check that it falls smoothly into the valve hole by its own weight.

If damaged, replace regulator valve set or oil pump assembly.

4. Check regulator valve to oil pump cover clearance.

Clearance:

6 : 0.040 - 0.097 mm (0.0016 - 0.0038 in)

If it exceeds the limit, replace oil pump assembly.

ENGINE LUBRICATION SYSTEM

Oil Pump (Cont'd)

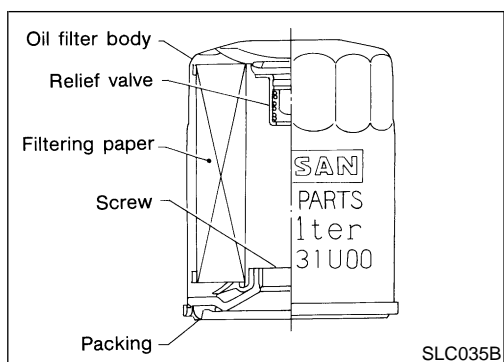

OIL FILTER

NDLC0009

The oil filter is a small, full-flow cartridge type and is provided with a relief valve.

- The new and previous oil filter designs differ from each other and are not interchangeable.
- Use Tool KV10115801 (J38956) for removing oil filter.

Service Data and Specifications (SDS)

OIL PRESSURE

NDLC0011

Engine speed rpm	Approximate discharge pressure kPa (kg/cm ² , psi)
Idle speed	More than 59 (0.6, 9)
2,000	412 - 451 (4.2 - 4.6, 60 - 65)

REGULATOR VALVE

NDLC0012

Unit: mm (in)

Regulator valve to oil pump cover clearance	0.040 - 0.097 (0.0016 - 0.0038)
---	---------------------------------

OIL PUMP

NDLC0013

Unit: mm (in)

Body to outer gear radial clearance	0.114 - 0.200 (0.0045 - 0.0079)
Inner gear to outer gear tip clearance	Below 0.18 (0.0071)
Body to inner gear axial clearance	0.05 - 0.09 (0.0020 - 0.0035)
Body to outer gear axial clearance	0.050 - 0.110 (0.0020 - 0.0043)
Inner gear to brazed portion of housing clearance	0.045 - 0.091 (0.0018 - 0.0036)

ENGINE COOLING SYSTEM

Precautions

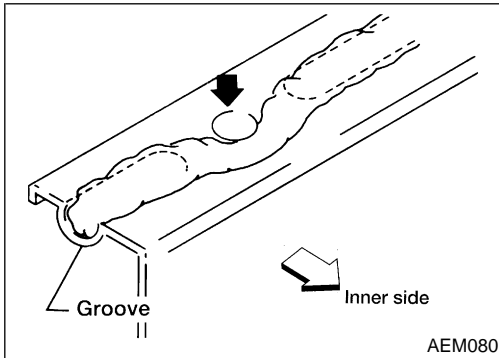
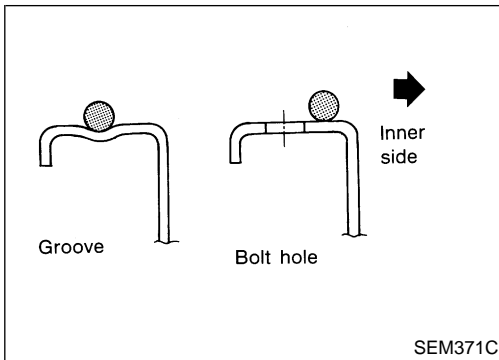

Precautions

LIQUID GASKET APPLICATION PROCEDURE

NDLC0014

1. Use a scraper to remove all traces of old liquid gasket from mating surface and grooves. Also, completely clean any oil from these areas.
2. Apply a continuous bead of liquid gasket to mating surfaces. (Use Genuine RTV Silicone Sealant Part No. 999MP-A7007 or equivalent).
 - Be sure liquid gasket is 3.5 to 4.5 mm (0.138 to 0.177 in) dia. (for oil pan).
 - Be sure liquid gasket is 2.0 to 3.0 mm (0.079 to 0.118 in) dia. (in areas except oil pan).
3. Apply liquid gasket around the inner side of bolt holes (unless otherwise specified).
4. Assembly should be done within 5 minutes after coating.
5. Wait at least 30 minutes before refilling engine oil and engine coolant.

GI

MA

EM

LC

EC

FE

AT

AX

SU

NDLC0015

BR

ST

RS

BT

HA

SC

EL

IDX

Preparation

SPECIAL SERVICE TOOLS

The actual shapes of Kent-Moore tools may differ from those of special service tools illustrated here.

Tool number (Kent-Moore No.) Tool name	Description
EG17650301 (J33984-A) Radiator cap tester adapter	<p>Adapting radiator cap tester to radiator filler neck a: 28 (1.10) dia. b: 31.4 (1.236) dia. c: 41.3 (1.626) dia. Unit: mm (in)</p>
WS39930000 () Tube presser	<p>Pressing the tube of liquid gasket</p>

ENGINE COOLING SYSTEM

Cooling Circuit

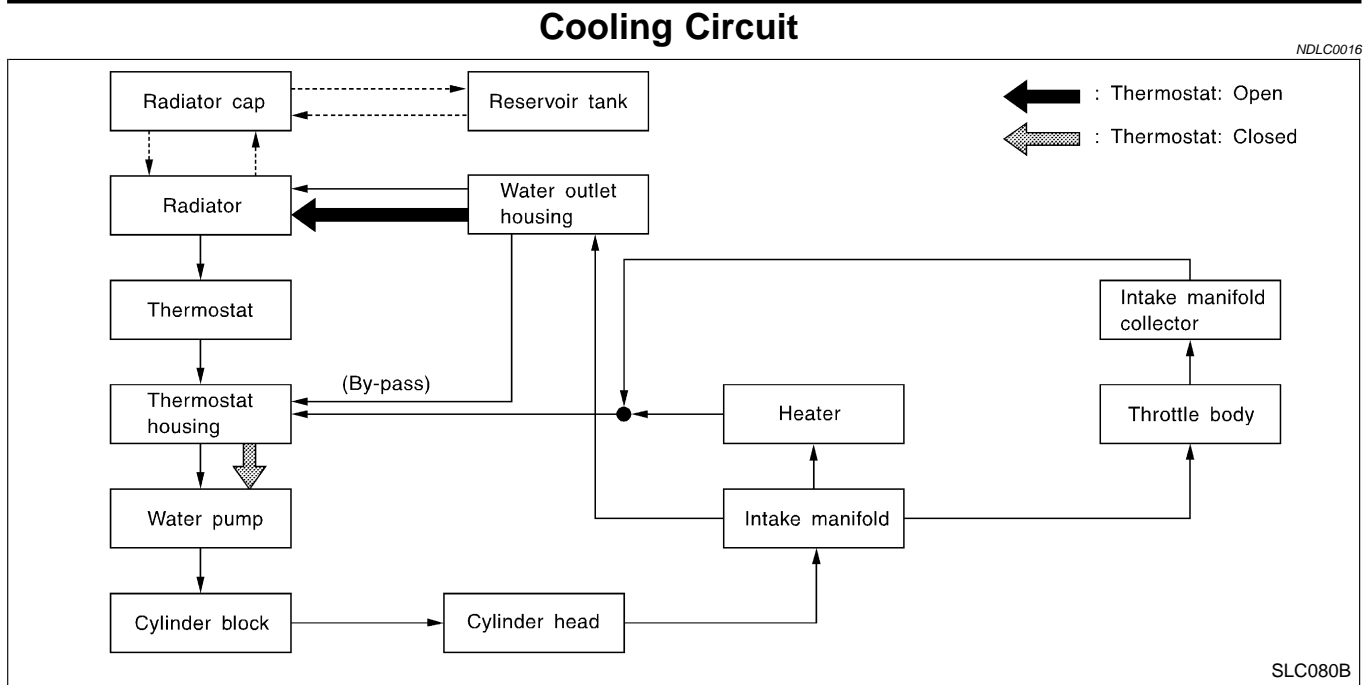

System Check

NDLC0017

WARNING:

Never remove the radiator cap when the engine is hot. Serious burns could occur from high pressure coolant escaping from the radiator.

Wrap a thick cloth around the cap. Slowly turn it a quarter turn to allow built-up pressure to escape. Carefully remove the cap by turning it all the way.

CHECKING COOLING SYSTEM HOSES

NDLC0017S01

Check hoses for improper attachment, leaks, cracks, damage, loose connections, chafing and deterioration.

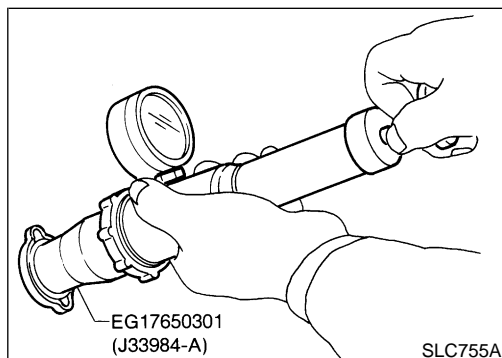

CHECKING RADIATOR CAP

NDLC0017S02

To check radiator cap, apply pressure to cap with a tester.

Radiator cap relief pressure:

Standard

78 - 98 kPa (0.8 - 1.0 kg/cm², 11 - 14 psi)

Limit

59 - 98 kPa (0.6 - 1.0 kg/cm², 9 - 14 psi)

ENGINE COOLING SYSTEM

System Check (Cont'd)

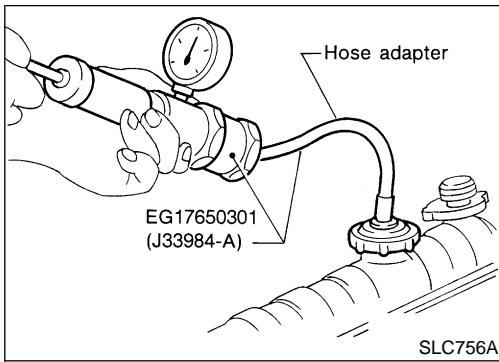

CHECKING COOLING SYSTEM FOR LEAKS

NDLC0017S03

To check for leakage, apply pressure to the cooling system with a tester.

Testing pressure: 157 kPa (1.6 kg/cm², 23 psi)

CAUTION:

Higher pressure than specified may cause radiator damage.

Water Pump REMOVAL

NDLC0018

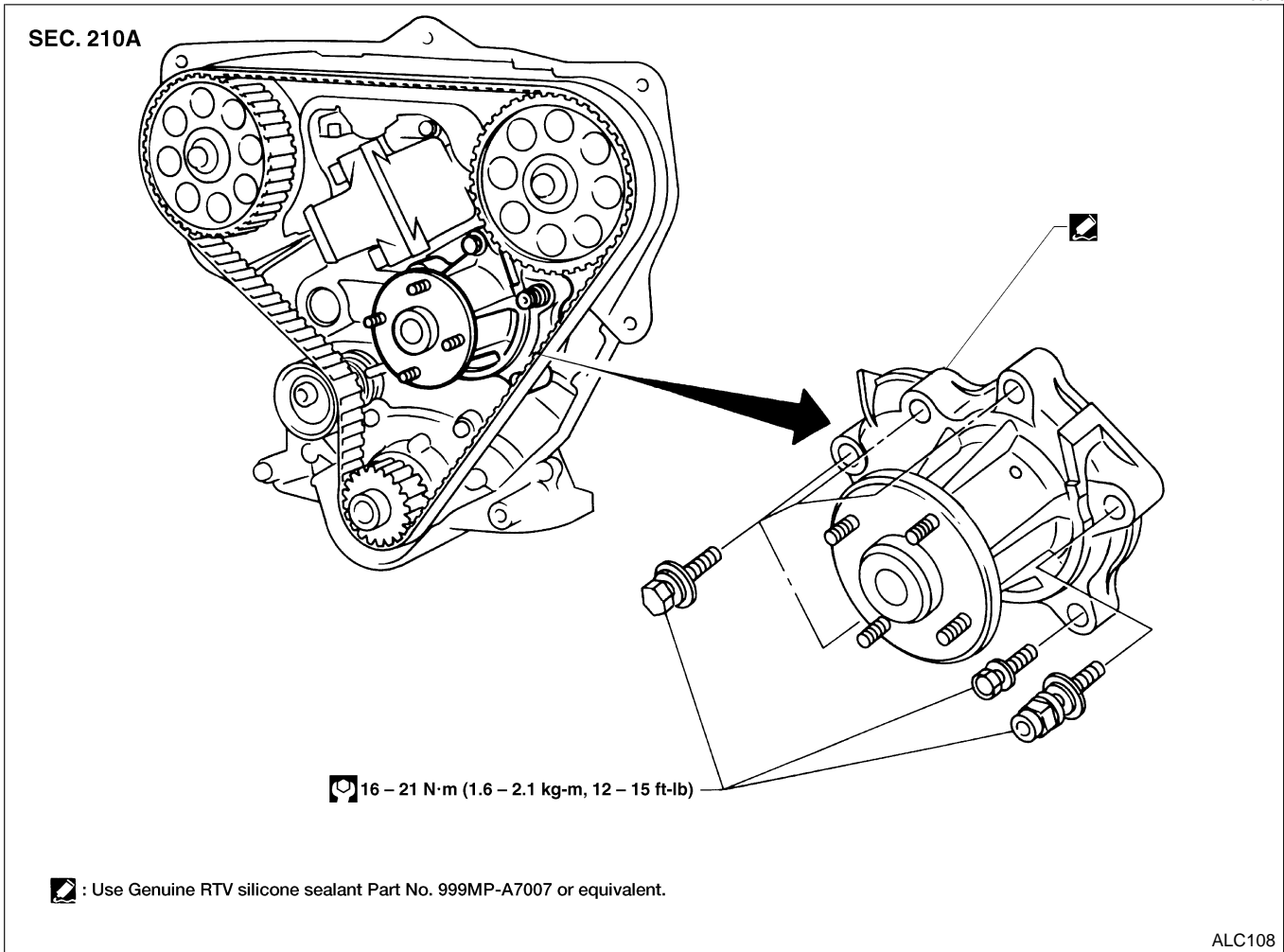

CAUTION:

- When removing water pump assembly, be careful not to get coolant on timing belt.
 - Water pump cannot be disassembled and should be replaced as a unit.
 - After installing water pump, connect hose and clamp securely, then check for leaks using radiator cap tester.
 - To avoid deforming timing cover, make sure there is adequate clearance between it and the hose clamp.
1. Drain coolant from cylinder block and radiator. Refer to **MA-14**, "Changing Engine Coolant".

ENGINE COOLING SYSTEM

Water Pump (Cont'd)

2. Remove radiator hoses (upper and lower) and fan shroud. Refer to "Radiator", LC-12.
3. Remove drive belts. Refer to **MA-13**, "Checking Drive Belts".
4. Remove water pump pulley.
5. Remove crankshaft pulley and front (upper and lower) belt cover. Refer to **EM-18**, "TIMING BELT".
6. Remove water pump.

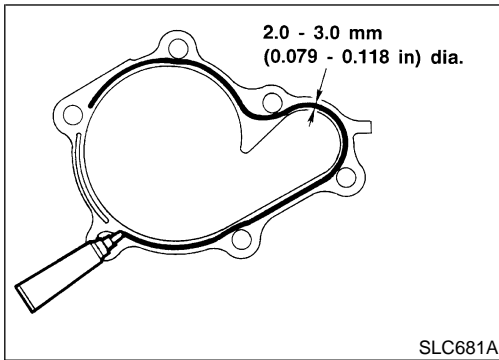
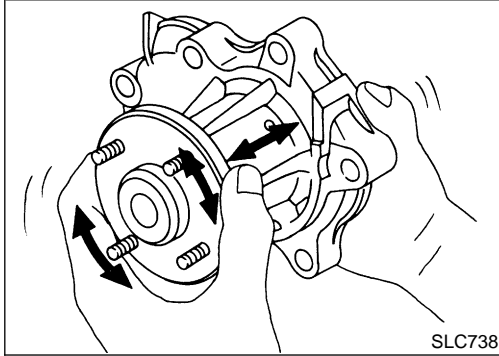

INSPECTION

1. Check for badly rusted or corroded body assembly and vanes. NDLC0019
2. Check for rough operation due to excessive end play.

INSTALLATION

1. Use a scraper to remove old liquid gasket from water pump. NDLC0036
 - **Also remove old liquid gasket from mating surface of cylinder block.**
2. Apply a continuous bead of liquid gasket to mating surface of water pump.
Use Genuine RTV Silicone Sealant Part No. 999MP-A7007 or equivalent.
3. Install water pump.
4. Install remaining parts in reverse order of removal.

When installing drive belts, refer to MA-13, "Checking Drive Belts".

When filling radiator with coolant, refer to MA-14, "Changing Engine Coolant".

Thermostat REMOVAL

NDLC0020

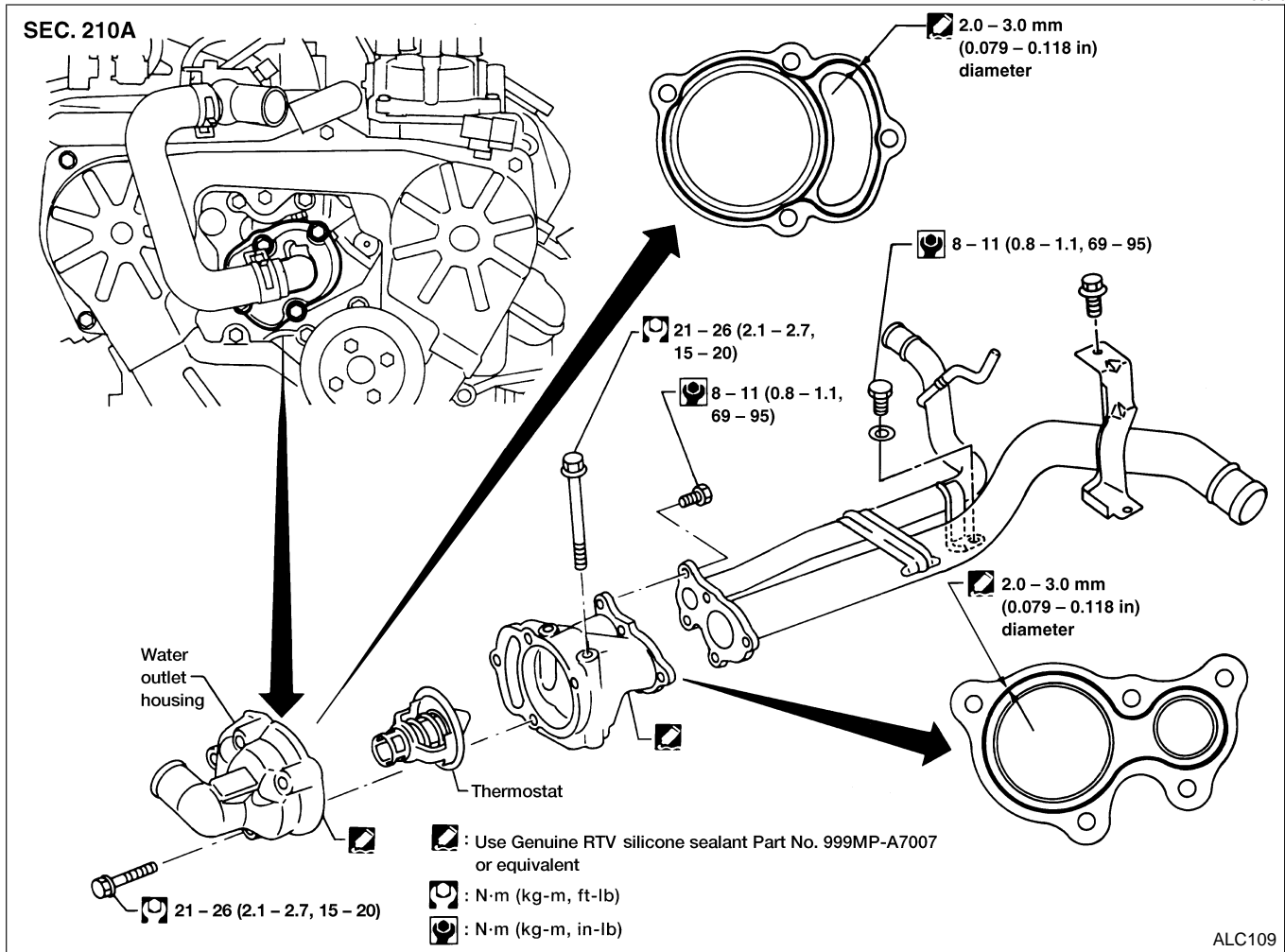

GI
MA
EM
LC
EC
FE
AT
AX
SU
BR
ST
RS

Be careful not to spill coolant over engine compartment. Use a rag to absorb coolant.

1. Drain engine coolant from drain plugs on radiator.
2. Remove radiator hoses (upper and lower) and fan shroud.
3. Remove drive belts.
4. Remove pulley bracket.
5. Remove water inlet and thermostat assembly.

INSPECTION

1. Check valve seating condition at ordinary temperatures. It should seat tightly.

NDLC0021

2. Check valve opening temperature and valve lift.

Valve opening temperature	°C (°F)	82 (180)
Valve lift	mm/°C (in/°F)	More than 10/90 (0.39/194)

3. Then check if valve is closed at 5°C (9°F) below valve opening temperature.

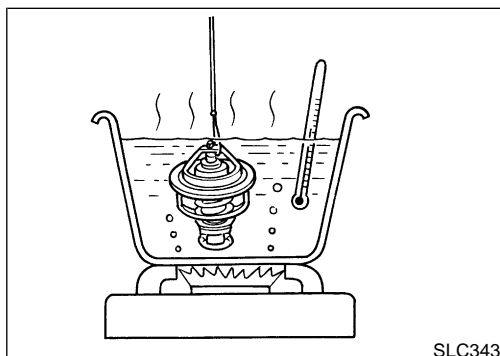

EL
IDX

ENGINE COOLING SYSTEM

Thermostat (Cont'd)

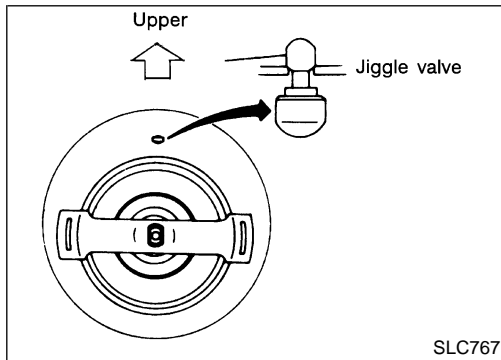
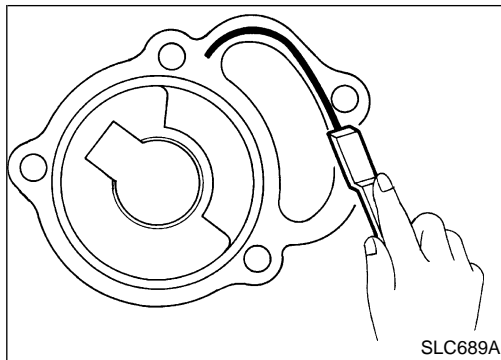

INSTALLATION

NDLC0022

1. Use a scraper to remove old liquid gasket from water outlet housing.
 2. Apply a continuous bead of liquid gasket to mating surface of water outlet housing.
Use Genuine RTV Silicone Sealant Part No. 999MP-A7007 or equivalent.
 3. Install thermostat with jiggle valve or air bleeder at upper side.
 4. Install water outlet housing.
 5. Install water hose to water outlet housing.
 6. Refill engine coolant. Refer to **MA-14**, "Changing Engine Coolant".
- **After installation, run engine for a few minutes, and check for leaks.**

Radiator REMOVAL AND INSTALLATION

NDLC0023

SEC. 214

4.6 – 6.5
(0.47 – 0.66, 41 – 57)
CAUTION: Use only specified bolts. If a bolt longer than 12 mm (0.47 in) is used, damage may occur to the wiring harness.

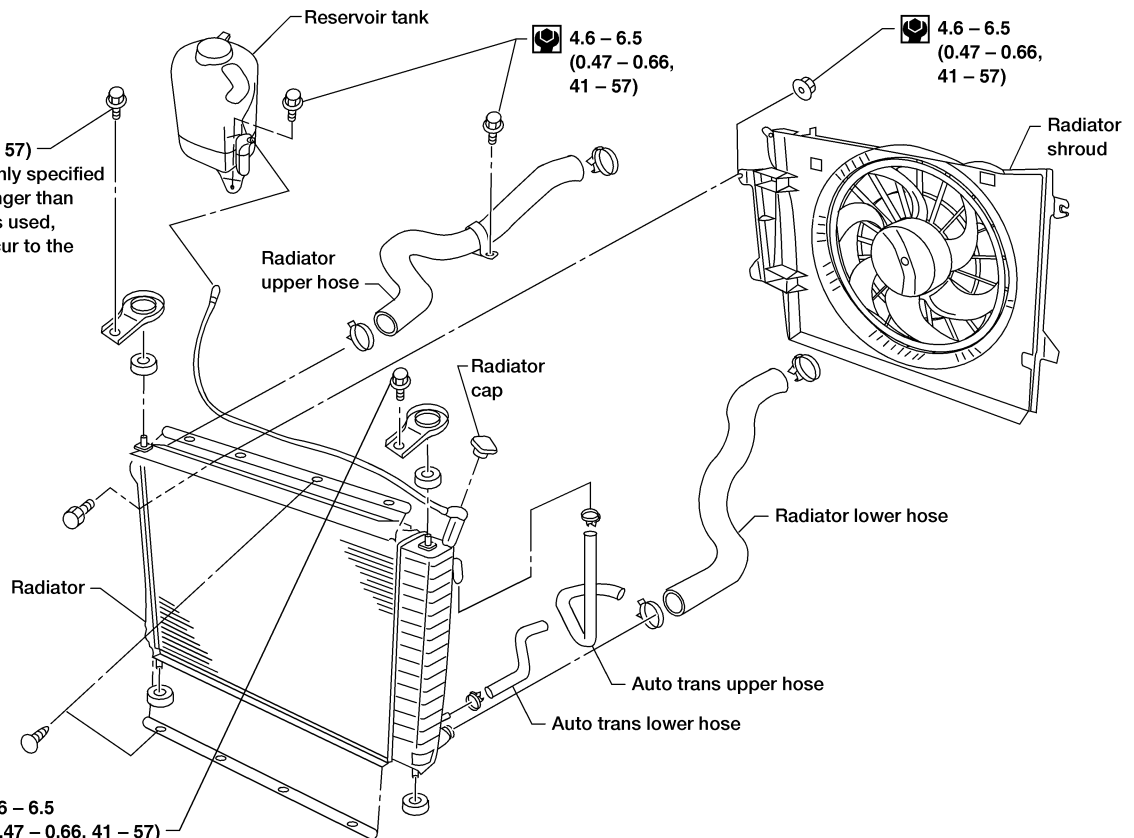

4.6 – 6.5
(0.47 – 0.66, 41 – 57)
CAUTION: Use only specified bolts. If a bolt longer than 12 mm (0.47 in) is used, damage may occur to the wiring harness.

⊙ : N·m (kg·m, in·lb)

WLC004

ENGINE COOLING SYSTEM

Radiator (Cont'd)

- Radiators are manufactured with saw cuts in the upper and lower center supports. Do not replace radiators because they have saw cuts in them.
1. Remove under cover.
 2. Drain coolant from radiator.
 3. Disconnect radiator upper and lower hoses.
 4. Remove A/T oil cooler hoses.
 5. Disconnect reservoir tank hose.
 6. Remove right bolt from fuse box and position fuse box aside.
 7. Disconnect cooling fan harness connector.
 8. Remove radiator.
 9. After repairing or replacing radiator, install all parts in reverse order of removal.
 10. Fill radiator with engine coolant.
- Proper heater performance and engine cooling requires accurately following “Refilling Engine Coolant”, LC-14.

GI

MA

EM

LC

EC

FE

AT

AX

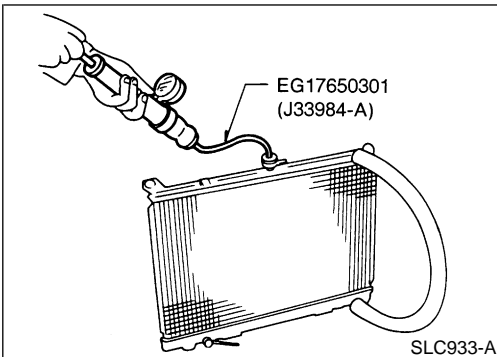

INSPECTION

1. Apply pressure with Tool.

Specified pressure value:

157 kPa (1.6 kg/cm², 23 psi)

WARNING:

To prevent the risk of the hose coming undone while under pressure, securely fasten it down with a hose clamp. Attach a hose to the oil cooler as well.

NDLC0028

SU

BR

ST

RS

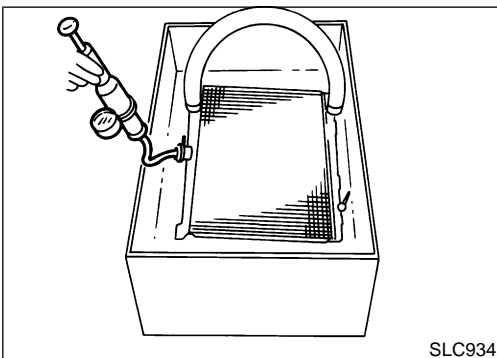

2. Check for leakage.

BT

HA

SC

EL

IDX

ENGINE COOLING SYSTEM

Refilling Engine Coolant

Refilling Engine Coolant

For details on refilling engine coolant, refer to **MA-14**, "Changing Engine Coolant". =NDLC0031

Overheating Cause Analysis

NDLC0032

		Symptom	Check items		
Cooling system parts malfunction	Poor heat transfer	Water pump malfunction	—	—	
		Thermostat stuck closed	—		
		Damaged fins	Dust contamination or paper clogging		—
			Mechanical damage		
		Clogged radiator cooling tube	Excess foreign material (rust, dirt, sand, etc.)		
	Reduced air flow	Cooling fan does not operate	—	—	
		High resistance to fan rotation			
		Damaged fan blades			
		Damaged radiator shroud	—	—	
		Improper coolant mixture ratio	—	—	
		Poor coolant quality	—	—	
	Insufficient coolant	Coolant leaks	Cooling hose	Loose clamp	
				Cracked hose	
			Water pump	Poor sealing	
Radiator cap			Loose		
		Poor sealing			
Radiator		O-ring for damage, deterioration or improper fitting			
		Cracked radiator tank			
		Cracked radiator core			
	Reservoir tank	Cracked reservoir tank			
Overflowing reservoir tank	Exhaust gas leaks into cooling system	Cylinder head deterioration			
		Cylinder head gasket deterioration			

ENGINE COOLING SYSTEM

Overheating Cause Analysis (Cont'd)

		Symptom		Check items		
Except cooling system parts malfunction	—	Overload on engine	Abusive driving	High engine rpm under no load	GI	
				Driving in low gear for extended time	MA	
				Driving at extremely high speed	EM	
			Powertrain system malfunction	—	LC	
			Installed improper size wheels and tires		EC	
			Dragging brakes		FE	
	Blocked or restricted air flow	Blocked bumper	—	—	AT	
			Blocked radiator grille		Installed car brassiere	AX
					Mud contamination or paper clogging	SU
			Blocked radiator		—	BR
			Blocked condenser		—	ST
	Installed large fog lamp	—	RS			

Cooling Fan Control System

Cooling fan is controlled by the ECM.
For details, refer to **EC-392**, "Cooling Fan Control".

NDLC0037

Service Data and Specifications (SDS)

THERMOSTAT

NDLC0033

Valve opening temperature °C (°F)	82 (180)
Valve lift mm/°C (in/°F)	More than 10/90 (0.39/194)

ENGINE COOLING SYSTEM

Service Data and Specifications (SDS) (Cont'd)

RADIATOR

Unit: kPa (kg/cm², psi)^{NDLC0034}

Cap relief pressure	Standard	78 - 98 (0.8 - 1.0, 11 - 14)
	Limit	59 - 98 (0.6 - 1.0, 9 - 14)
Leakage test pressure		157 (1.6, 23)