

SECTION **ST**

CI

MA

EM

LC

EC

FE

AT

FA

RA

BR

ST

RS

BT

HA

EL

IDX

CONTENTS

PRECAUTIONS AND PREPARATION	2	STEERING WHEEL AND STEERING COLUMN	9
Supplemental Restraint System (SRS) "AIR BAG"	2	Removal	9
Steering System	2	Installation	10
Special Service Tools.....	2	Disassembly and Assembly.....	11
Commercial Service Tool	4	Inspection.....	13
ON-VEHICLE SERVICE	5	POWER STEERING GEAR AND LINKAGE	14
Checking and Adjusting Drive Belts	5	Removal and Installation	14
Checking Fluid Level	5	Description	16
Checking Fluid Leakage	5	Disassembly.....	17
Bleeding Hydraulic System.....	5	Inspection.....	17
Checking Steering Wheel Turning Force (For power steering)	6	Assembly.....	18
Checking Steering Wheel Play.....	6	POWER STEERING OIL PUMP	20
Checking Neutral Position on Steering Wheel	7	Pre-disassembly Inspection	20
Front Wheel Turning Angle.....	7	Inspection	21
Checking Gear Housing Movement.....	7	Disassembly.....	21
Checking Hydraulic System.....	7	Assembly.....	21
		SERVICE DATA AND SPECIFICATIONS (SDS)	23
		General Specifications	23
		Inspection and Adjustment.....	23

PRECAUTIONS AND PREPARATION



Supplemental Restraint System (SRS) "AIR BAG"

The Supplemental Restraint System "Air Bag" used along with a seat belt, helps to reduce the risk of severity of injury to the driver and front passenger in a frontal collision. The Supplemental Restraint System consists of air bag modules (located in the center of the steering wheel and on the instrument panel on the passenger side), a diagnosis sensor unit, warning lamp, wiring harness and spiral cable. Information necessary to service the system safety is included in the **RS section** of this Service Manual.

WARNING:

- To avoid rendering the SRS inoperative, which could increase the risk of personal injury or death in the event of a collision which would result in air bag inflation, all maintenance must be performed by an authorized NISSAN dealer.
- Improper maintenance, including incorrect removal and installation of the SRS, can lead to personal injury caused by unintentional activation of the system.
- Do not use electrical test equipment on any circuit related to the SRS unless instructed to in this Service Manual. SRS wiring harnesses are covered with yellow insulation either just before the harness connectors or for the complete harness, for easy identification.

STEERING SYSTEM

- Before disassembly, thoroughly clean the outside of the unit.
- Disassembly should be done in a clean work area. It is important to prevent the internal parts from becoming contaminated by dirt or other foreign matter.
- For easier and proper assembly, place disassembled parts in order on a parts rack.
- Use nylon cloths or paper towels to clean the parts; common shop rags can leave lint that might interfere with their operation.
- Before inspection or reassembly, carefully clean all parts with a general purpose, non-flammable solvent.
- Before assembly, apply a coat of Type F Automatic Transmission Fluid to the hydraulic parts. Petroleum jelly may be applied to O-rings and seals. Do not use any grease.
- Replace all gaskets, seals and O-rings. Avoid damaging O-rings, seals and gaskets during installation. Perform functional tests whenever designated.

Special Service Tools

The actual shapes of Kent-Moore tools may differ from those of special service tools illustrated here.

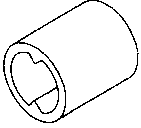
Tool number (Kent-Moore No.) Tool name	Description
KV48100700 (J26364) Torque adapter	 Measuring pinion rotating torque NT169

PRECAUTIONS AND PREPARATION

Special Service Tools (Cont'd)

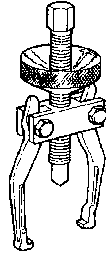
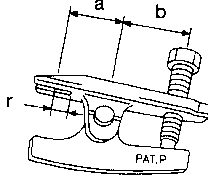
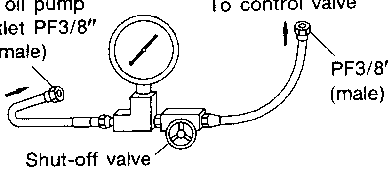
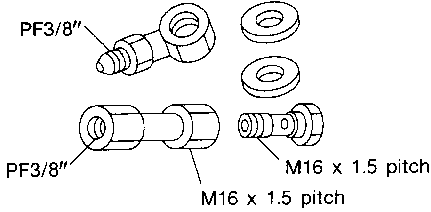
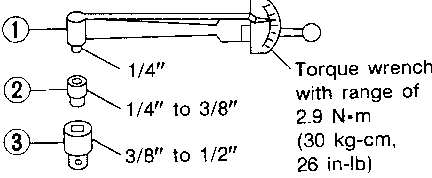
Tool number (Kent-Moore No.) Tool name	Description	
(J41777) Steering wheel puller	 <p style="text-align: center;">AST162</p>	GI NA EM LC
HT72520000 (J25730-B) Ball joint remover	 <p style="text-align: center;">NT546</p>	EC FE AT
ST27091000 (J26357) Pressure gauge	 <p style="text-align: center;">NT547</p>	RA FA RA
KV48102500 (—) Pressure gauge adapter	 <p style="text-align: center;">NT542</p>	BR ST RS
ST3127S000 ① GG91030000 (See J25765-A) Torque wrench ② HT62940000 (—) Socket adapter ③ HT62900000 (—) Socket adapter	 <p style="text-align: center;">NT541</p>	BT HA EL IDX

PRECAUTIONS AND PREPARATION

Commercial Service Tool

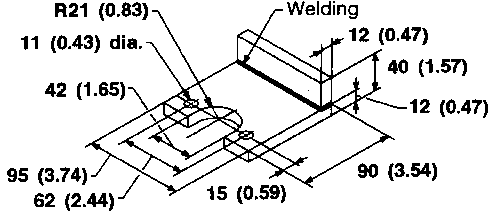
Tool name	Description
Oil pump attachment	<p data-bbox="1024 268 1458 296">Disassembling and assembling oil pump</p>  <p data-bbox="456 527 688 554">NT179 Unit: mm (in)</p> <p>The technical drawing shows a perspective view of a rectangular metal tool with a raised section on one end. Dimensions are provided in millimeters and inches in parentheses. The main body is 95 mm (3.74 in) long and 62 mm (2.44 in) wide. The raised section is 15 mm (0.59 in) wide and 12 mm (0.47 in) high. The top surface of the raised section is 40 mm (1.57 in) long. The tool has a radius of R21 (0.83 in) on the top edge of the main body and a diameter of 11 mm (0.43 in) for a hole. The word 'Welding' is written near the raised section.</p>

Checking and Adjusting Drive Belts

Refer to MA section ("Checking Drive Belts", "ENGINE MAINTENANCE").

GI

MA

EM

LC

EC

FE

AT

FA

RA

BR

ST

RS

BT

HA

EL

IDX

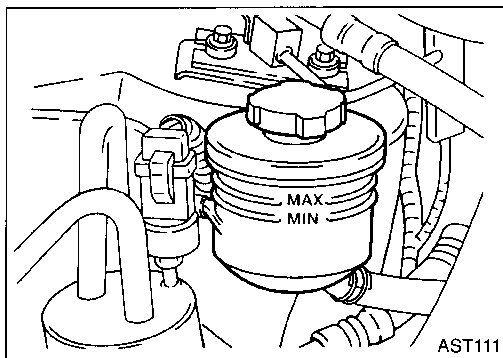

AST111

Checking Fluid Level

Check fluid level by referring to the scale on reservoir tank. Fluid level should be checked at fluid temperatures of 0 to 30°C (32 to 86°F).

CAUTION:

- Do not overfill.
- Recommended fluid is Type F Automatic Transmission Fluid.

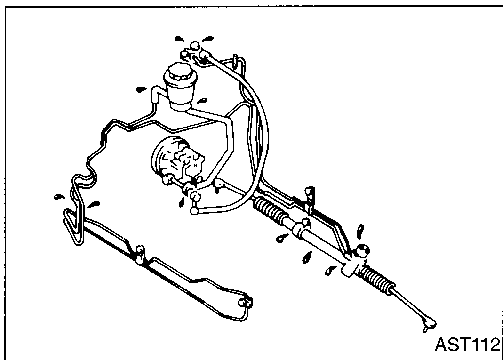

AST112

Checking Fluid Leakage

Check the lines for improper attachment, leaks, cracks, damage, chafing or deterioration.

1. Run engine at idle speed or 1,000 rpm.

Make sure fluid temperature in reservoir tank rises to 60 to 80°C (140 to 176°F).

2. Turn steering wheel right-to-left several times.
3. Hold steering wheel at each "lock" position for five seconds and carefully check for fluid leakage.

CAUTION:

Do not hold the steering wheel in a locked position for more than 15 seconds.

4. If fluid leakage from any line is noticed, loosen flare nut and then retighten.

- Do not overtighten flare nut as this can damage O-ring, washer and threads.

5. Check rack boots for accumulation of power steering fluid.

Bleeding Hydraulic System

1. Raise front end of vehicle until wheels are clear of the ground.
2. Add fluid into reservoir tank to specified level. Then quickly turn steering wheel fully to right and left and lightly touch steering stoppers.

Repeat steering wheel operation until fluid level no longer decreases.

3. Start engine.
Repeat step 2.

ON-VEHICLE SERVICE

Bleeding Hydraulic System (Cont'd)

- Incomplete air bleeding will cause the following to occur:
 - a. Air bubbles in reservoir tank
 - b. Clicking noise in power steering pump
 - c. Excessive buzzing in power steering pumpWhen this happens, bleed air again.

Fluid noise may occur in the valve or power steering pump. This is common when the vehicle is stationary or while turning the steering wheel slowly. This does not affect the performance or durability of the system.

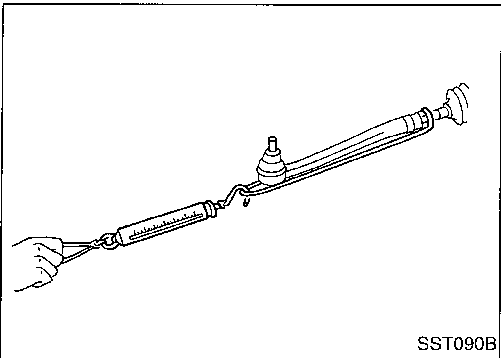
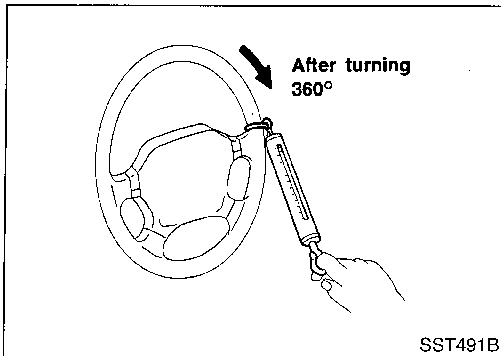

Checking Steering Wheel Turning Force (For power steering)

1. Park vehicle on a level, dry surface and set parking brake.
 2. Run engine at idle speed or 1,000 rpm.
 3. Bring power steering fluid up to operating temperature.
- **Make sure fluid temperature in reservoir tank rises to 60 to 80°C (140 to 176°F).**
 - **Tires need to be inflated to normal pressure.**
4. Check steering wheel turning force when steering wheel has been turned 360° from the neutral position.

Steering wheel turning force:

39 N (4 kg, 9 lb) or less

5. If steering wheel turning force is out of specification, check rack sliding force.
 - a. Disconnect steering column lower joint and knuckle arms from the gear.
 - b. Start and run engine at idle to make sure steering fluid has reached normal operating temperature.
 - c. Pull tie-rod slowly to move it from neutral position to ± 11.5 mm (± 0.453 in) at speed of 3.5 mm (0.138 in)/s. Check that rack sliding force is within specification.

Average rack sliding force:

108 - 284 N (11 - 29 kg, 24 - 64 lb)

Maximum rack sliding force:

324 N (33 kg, 73 lb)

6. If rack sliding force is not within specification, refer to "Checking Hydraulic System", ST-7.
7. If rack sliding force is OK, inspect steering column. Refer to ST-13.

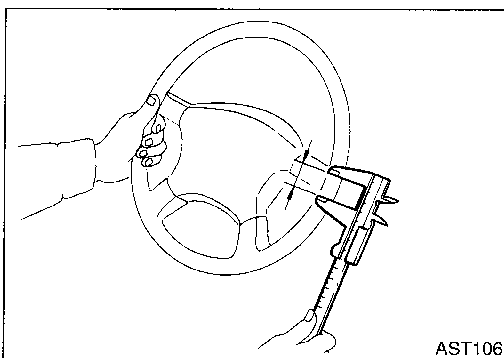

Checking Steering Wheel Play

- With wheels in a straight-ahead position, check steering wheel play.

Steering wheel play:

35 mm (1.38 in) or less

- If it is not within specification, check the following for loose or worn components.
 - (1) Steering gear assembly
 - (2) Steering column
 - (3) Front suspension and axle

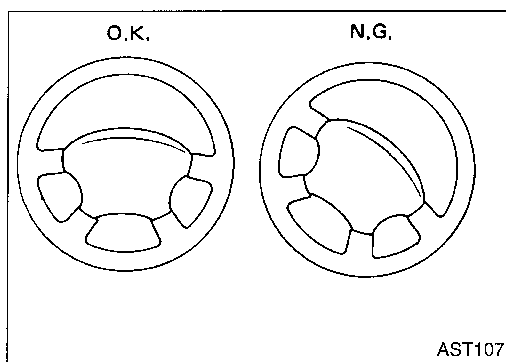

Checking Neutral Position on Steering Wheel

Pre-checking

- Make sure that wheel alignment is correct.
Wheel alignment:
Refer to FA section ("Inspection and Adjustment", "SERVICE DATA AND SPECIFICATIONS").
- Verify that the steering gear is centered before removing the steering wheel.

Checking

1. Check that the steering wheel is in the neutral position when driving straight ahead.
2. If it is not in the neutral position, remove the steering wheel and reinstall it correctly.
3. If the neutral position is still not correct:
 - a. Loosen tie-rod lock nuts.
 - b. Move tie-rods in the opposite direction by the same amount on both left and right sides. This will compensate for error in the neutral position.

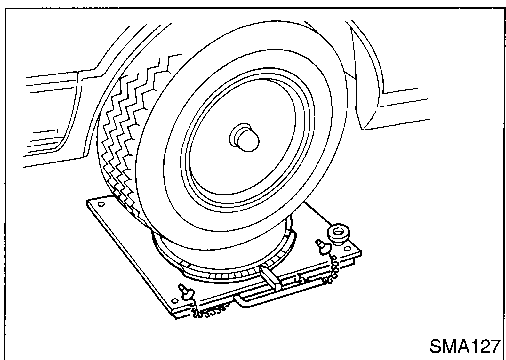

Front Wheel Turning Angle

1. Rotate steering wheel all the way right and left; measure turning angle.

Turning angle of full turns:

Refer to FA section ("Inspection and Adjustment", "SERVICE DATA AND SPECIFICATIONS").

2. If it is not within specification, check rack stroke.
Rack stroke "L":
Refer to ST-24.

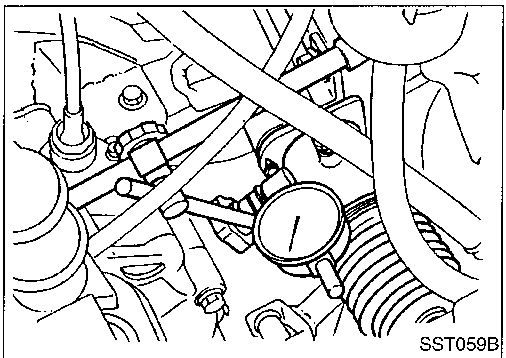

Checking Gear Housing Movement

1. Check the movement of steering gear housing during stationary steering on a dry paved surface.
 - Apply a force of 49 N (5 kg, 11 lb) to steering wheel to check the gear housing movement.
Turn off ignition key while checking.
Movement of gear housing:
 $\pm 2 \text{ mm } (\pm 0.08 \text{ in})$ or less
2. If movement exceeds the limit, replace mounting insulator after confirming proper installation of gear housing mounting brackets.

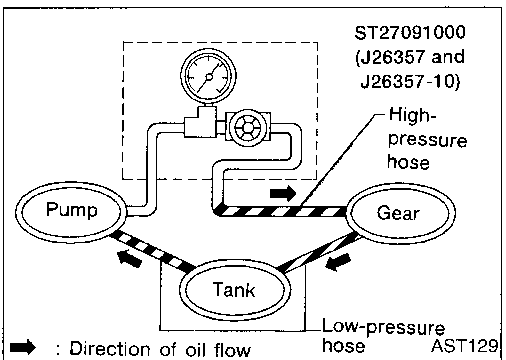

Checking Hydraulic System

Before starting, check belt tension, driving pulley and tire pressure.

1. Set Tool. Open shut-off valve. Then bleed air. Refer to "Bleeding Hydraulic System", ST-5.
2. Run engine at idle speed or 1,000 rpm.
 - **Make sure fluid temperature in reservoir tank rises to 60 to 80°C (140 to 176°F).**

Checking Hydraulic System (Cont'd)

WARNING:

Warm up engine with shut-off valve fully opened. If engine is started with shut-off valve closed, fluid pressure in power steering pump increases to maximum. This will raise fluid temperature abnormally.

3. Check pressure with steering wheel fully turned to left and right positions with engine idling at 1,000 rpm.

CAUTION:

Do not hold the steering wheel in a locked position for more than 15 seconds.

4. If power steering pressure is at standard pressure, measure pinion rotating torque. Refer to ST-17.

Power steering pump maximum pressure:

7,355 - 8,336 kPa

(75 - 85 kg/cm², 1,067 - 1,209 psi)

5. If power steering pressure is below the standard pressure, slowly close shut-off valve and check pressure.

CAUTION:

Do not close shut-off valve for more than 15 seconds.

- When pressure reaches standard pressure, gear is damaged. Replace power steering gear. Refer to "Removal and Installation", ST-14.
 - When pressure remains below standard pressure, pump is damaged. Replace power steering pump.
6. If power steering pressure is higher than standard pressure, power steering pump flow control valve is damaged. Replace power steering pump.
 7. After checking hydraulic system, remove Tool and add fluid as necessary. Then completely bleed air out of system.

STEERING WHEEL AND STEERING COLUMN

Removal and Installation

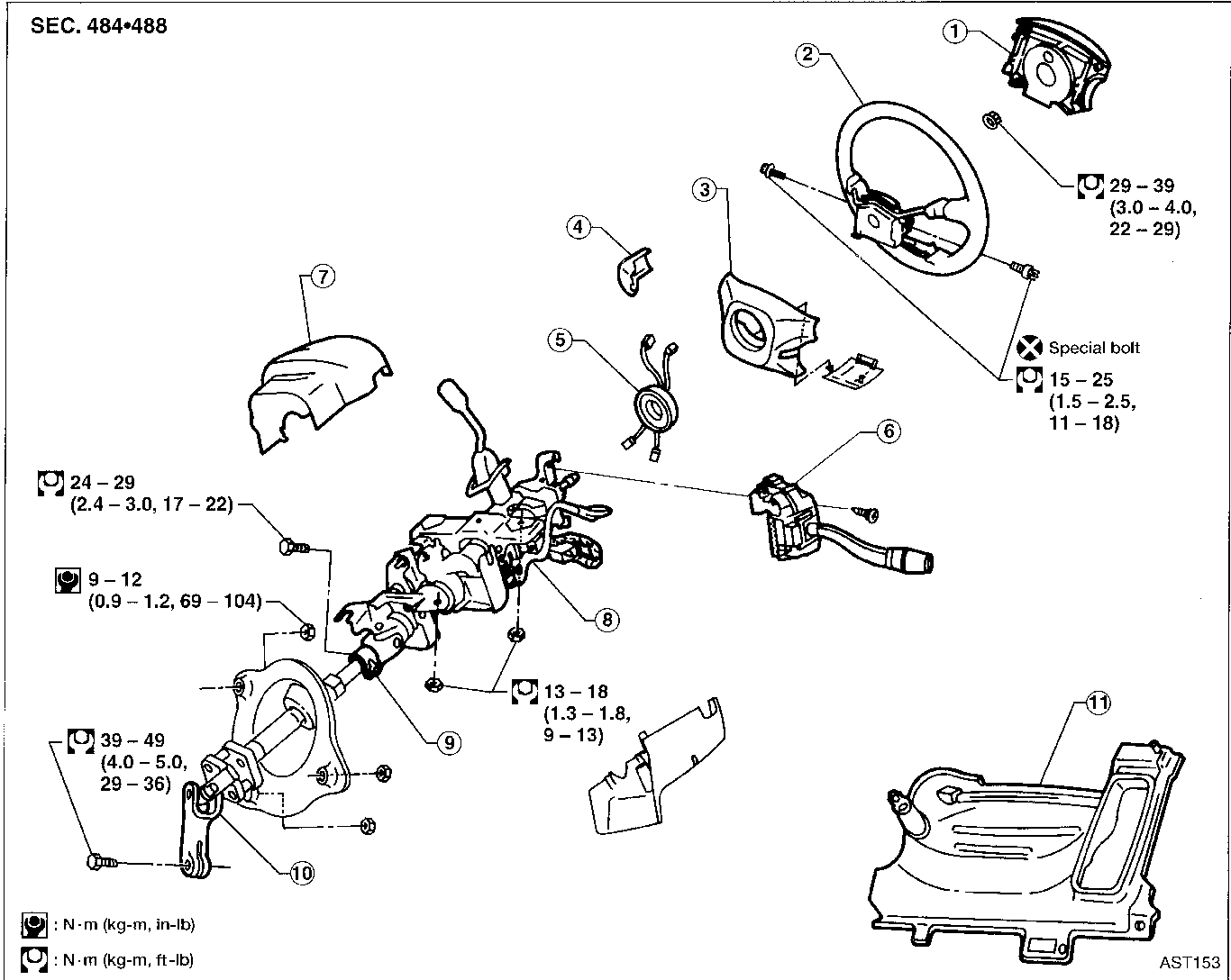

- | | | |
|------------------------|----------------------------|------------------------------|
| ① Air bag module | ⑤ Spiral cable | ⑨ Upper joint |
| ② Steering wheel | ⑥ Combination switch | ⑩ Lower joint |
| ③ Steering wheel cover | ⑦ Column cover | ⑪ Driver lower reinforcement |
| ④ Side cover | ⑧ Steering column assembly | |

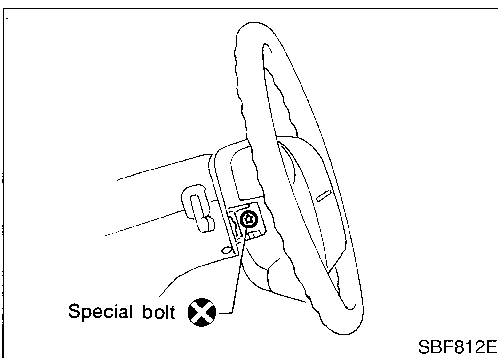

Removal

STEERING WHEEL

- Remove air bag module and spiral cable. Refer to RS section ["Removal — Air Bag Module and Spiral Cable", "SUPPLEMENTAL RESTRAINT SYSTEM (SRS)"].
- Disconnect horn connector and remove steering wheel nut.

STEERING WHEEL AND STEERING COLUMN

Removal (Cont'd)

- Remove steering wheel with puller.

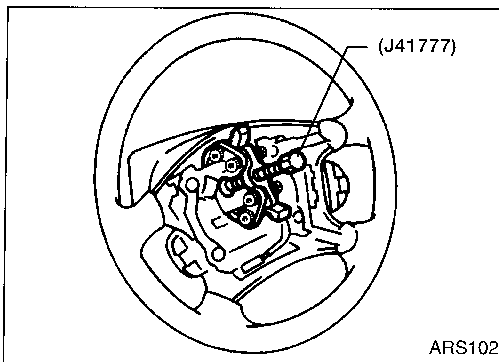

STEERING COLUMN

CAUTION:

- The rotation of the spiral cable (SRS "Air bag" component part) is limited. If the steering gear must be removed, set the front wheels in the straight-ahead direction. Do not rotate the steering column while the steering gear is removed.
 - Remove the steering wheel before removing the steering lower joint to avoid damaging the SRS spiral cable. Refer to ST-9
1. Remove driver lower finisher and reinforcement.
 2. Remove position indicator wire.
 3. Remove side ventilator duct on driver side.
 4. Remove shift control cable.
 5. Disconnect electrical connectors from ignition switch, shift lock solenoid and combination switch.
 6. Remove two screws securing combination switch and remove combination switch.
 7. Remove four nuts attaching steering column and remove steering column.

Installation

STEERING COLUMN

- Align spiral cable correctly when installing steering wheel. Refer to RS section ["Installation—Air Bag Module and Spiral Cable", "SUPPLEMENTAL RESTRAINT SYSTEM (SRS)"].
 - When installing steering column, fingertighten all lower bracket and clamp retaining bolts; then tighten them securely. Do not apply undue stress to steering column.
 - When attaching upper joint, be sure tightening bolt faces cutout portion.
- When installing intermediate shaft, align slit of lower joint with pinion shaft. Insert joint until surface A contacts surface B.

CAUTION:

After installation, turn steering wheel to make sure it moves smoothly. Ensure the number of turns from the straight forward position to left and right locks are the same. Be sure that the steering wheel is in a neutral position when driving straight ahead.

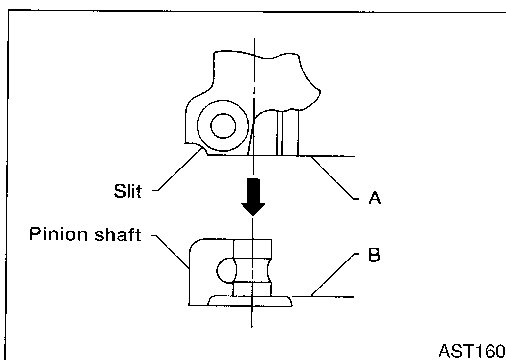
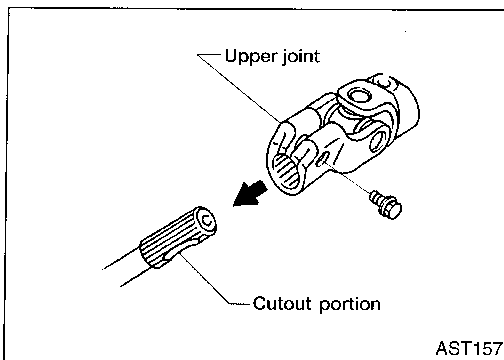

STEERING WHEEL AND STEERING COLUMN

Disassembly and Assembly

SEC. 484•488

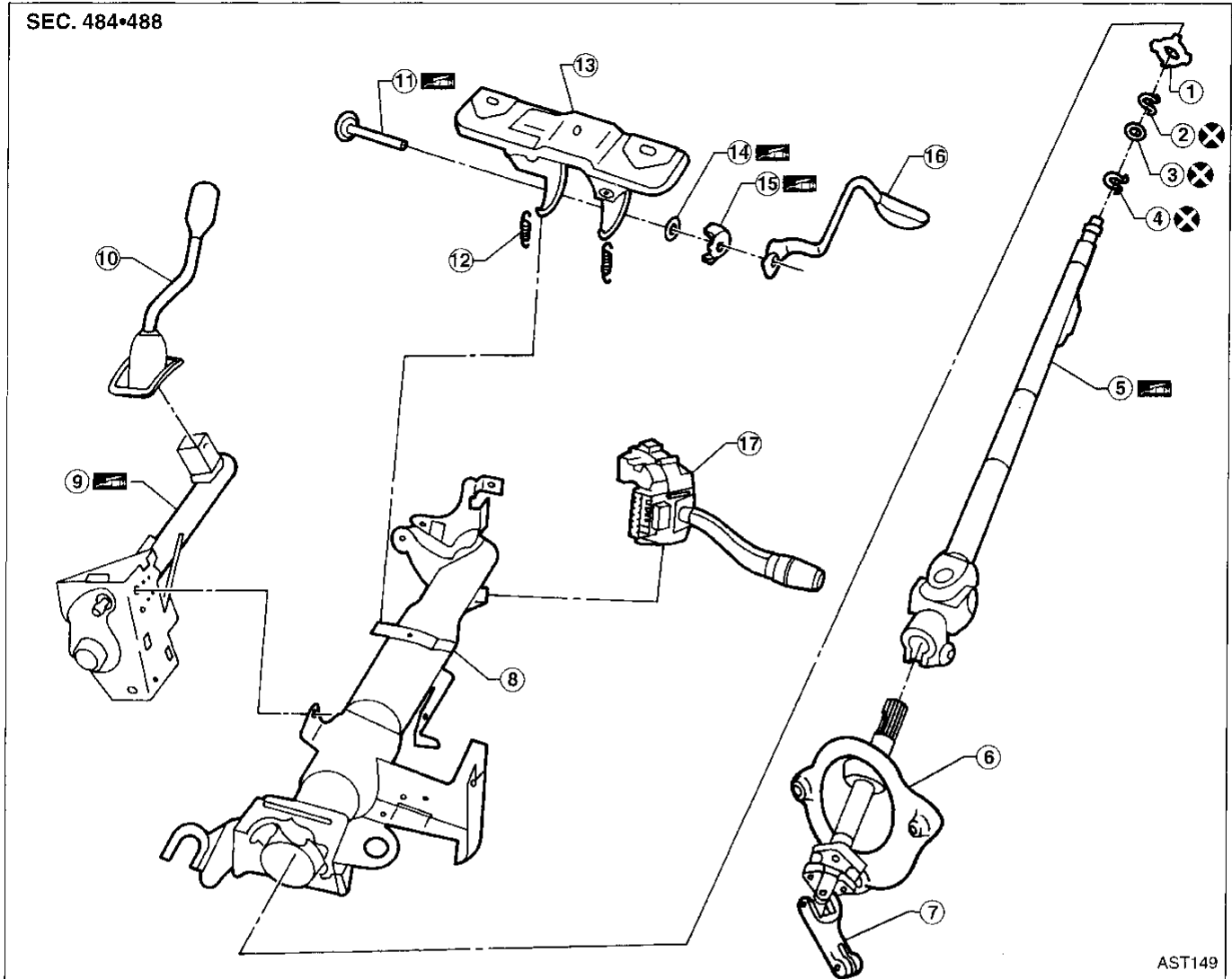

- ① Turn signal cancel cam
- ② Snap ring (A)
- ③ O-ring
- ④ Snap ring (B)
- ⑤ Column shaft assembly
- ⑥ Cover

- ⑦ Lower joint
- ⑧ Jacket tube assembly
- ⑨ Shift control tube
- ⑩ Selector lever
- ⑪ Adjusting bolt
- ⑫ Spring

- ⑬ Steering column mounting bracket
- ⑭ Washer
- ⑮ Tilt lever stopper
- ⑯ Tilt lever
- ⑰ Combination switch

1. When disassembling and assembling, unlock steering lock with key.
2. Remove bolt attaching shift control tube and remove shift control tube.

STEERING WHEEL AND STEERING COLUMN

Disassembly and Assembly (Cont'd)

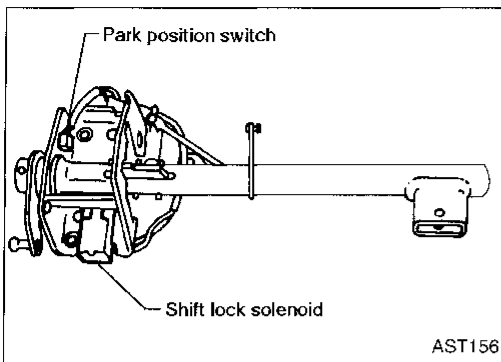

3. Remove four screws securing shift lock solenoid and park position switch.

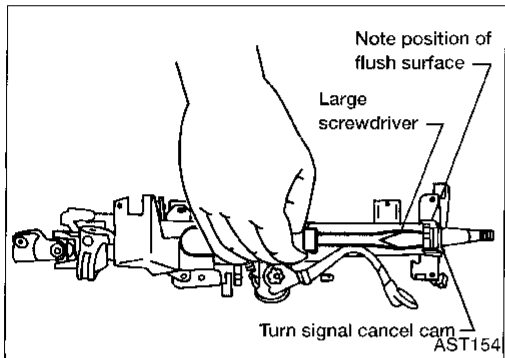

4. Remove turn signal cancel cam by pushing up with a flat-bladed screwdriver.
5. Remove snap ring (A) from column shaft and remove column shaft assembly.

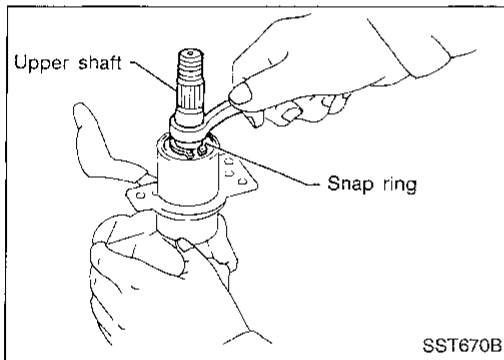

6. Ensure that rounded surface of snap ring faces toward bearing when snap ring is installed. Install snap ring on upper shaft with a suitable tool.

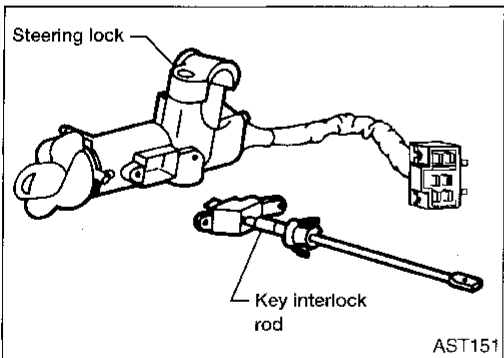

Steering lock

1. Remove shift lock rod from steering lock.

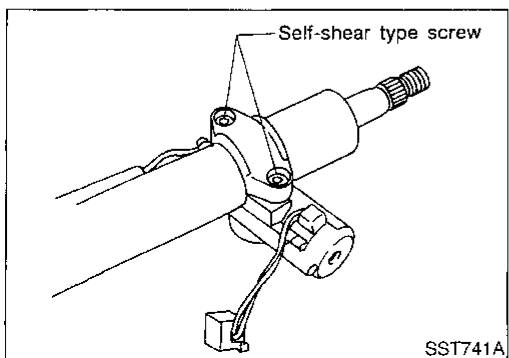

2. Break self-shear type screws with a drill or other appropriate tool and remove steering lock.

STEERING WHEEL AND STEERING COLUMN

Disassembly and Assembly (Cont'd)

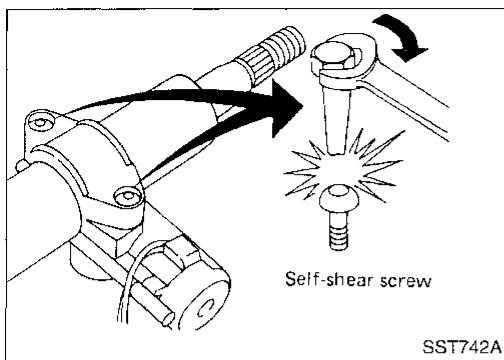

3. Install self-shear type screws, then tighten until heads break off.

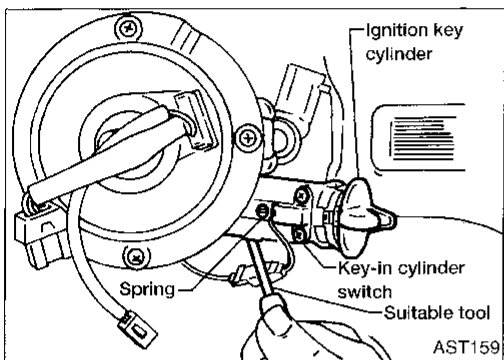

Ignition key cylinder

CAUTION:

Spring will pop out of steering lock when ignition key cylinder is removed.

1. Remove two screws securing key-in cylinder switch.
2. Remove shift lock rod.
3. Turn ignition key cylinder to the ON position and depress tab using a suitable tool.
4. Remove ignition key cylinder.

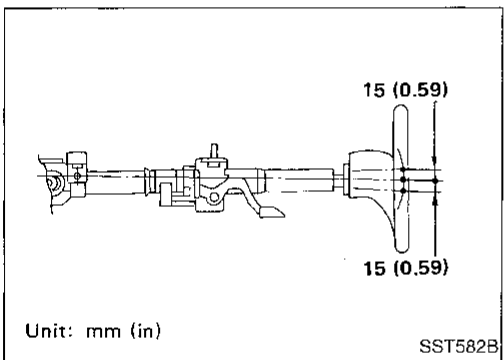

Tilt mechanism

1. Remove two springs.

CAUTION:

Springs are under tension.

2. Remove adjusting bolt.
 - Adjusting bolt has left-hand threads.
3. Remove tilt lever and steering column mounting bracket.
4. After installing steering column, check tilt mechanism operation.

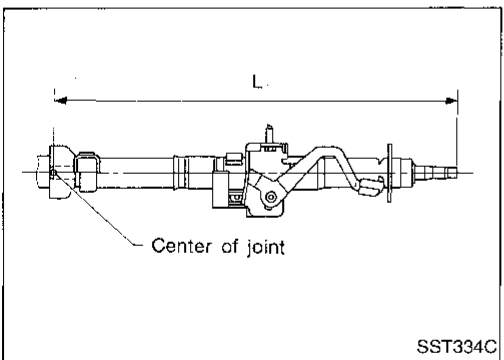

Inspection

- When steering wheel does not turn smoothly, check the steering column as follows and replace damaged parts.
 - a. Check column bearings for damage or unevenness. Lubricate with recommended multi-purpose grease or replace steering column as an assembly, if necessary.
 - b. Check jacket tube for deformation or breakage.
- When the vehicle is involved in a light collision, check column length "L". If it is not within specifications, replace steering column as an assembly.

Column length "L":

505.5 - 507.1 mm (19.90 - 19.96 in)

GI

MA

EM

LC

EC

FE

AT

FA

BA

BR

ST

RS

BT

HA

ET

DX

POWER STEERING GEAR AND LINKAGE

Removal and Installation

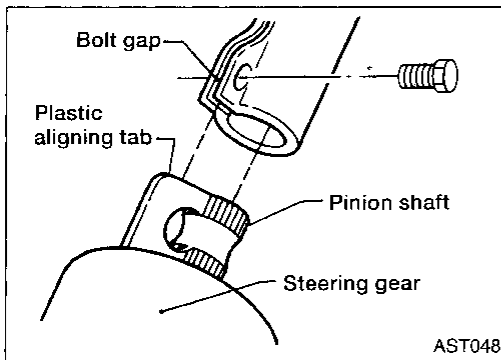
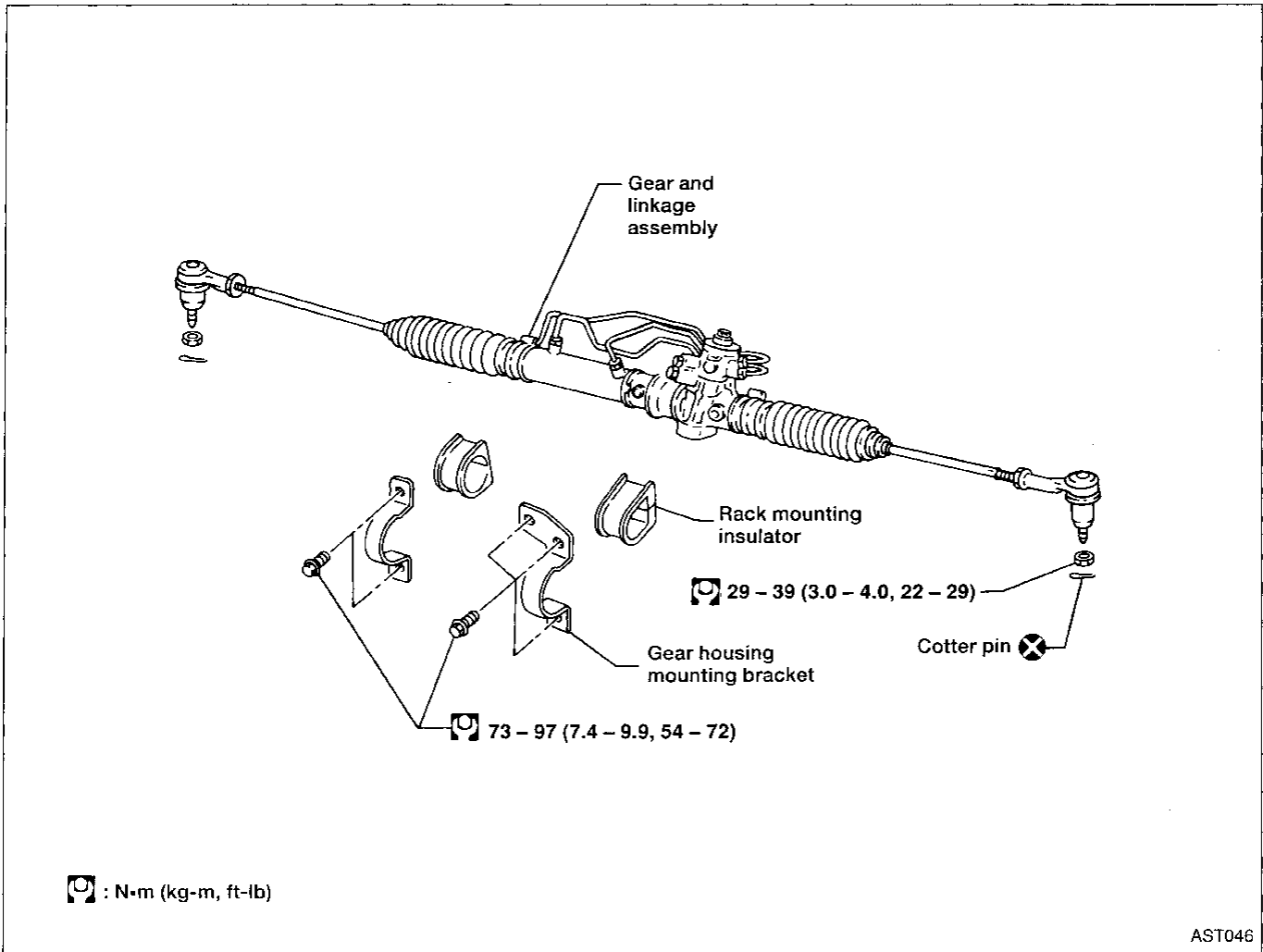

CAUTION:

The rotation of the spiral cable (SRS "Air Bag" component part) is limited. If the steering gear must be removed, set the front wheels in the straight-ahead direction. Do not rotate the steering column while the steering gear is removed.

- Before removing lower joint from gear, set gear in neutral (wheels in straight-ahead position).
- To install, set left and right dust boots to equal deflection. Raise steering gear and linkage assembly so plastic aligning tab on pinion shaft enters bolt gap on lower joint assembly.

Service parts may not have plastic aligning tab.

POWER STEERING GEAR AND LINKAGE

Removal and Installation (Cont'd)

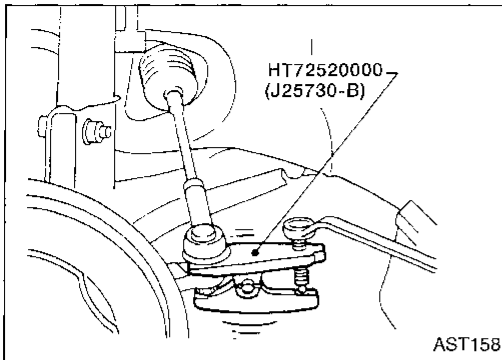

- Detach tie-rod outer sockets from knuckle arms with Tool.

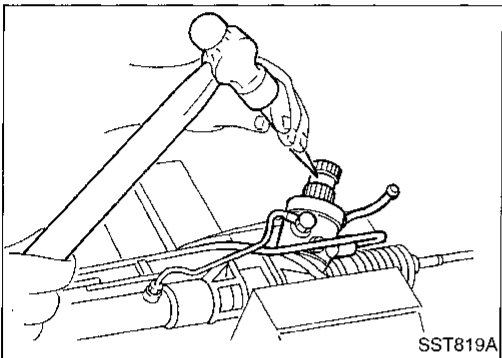

- After removing steering gear from vehicle, mark pinion shaft and pinion housing to record neutral position.
- To install, set left and right dust boots to equal deflection. Align matching marks on pinion shaft and pinion housing.

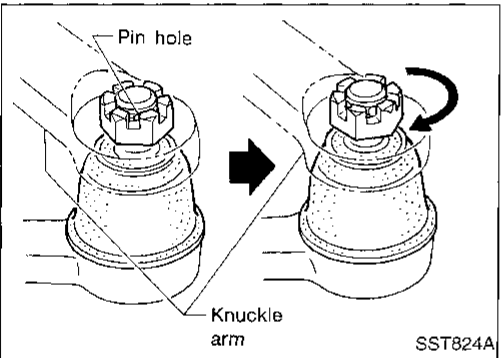

- Initially tighten nut on tie-rod outer socket and knuckle arm to 29 to 39 N·m (3 to 4 kg-m, 22 to 29 ft-lb). Then tighten further to align nut groove with first pin hole so that cotter pin can be installed.

CAUTION:

Tightening torque must not exceed 49 N·m (5 kg-m, 36 ft-lb).

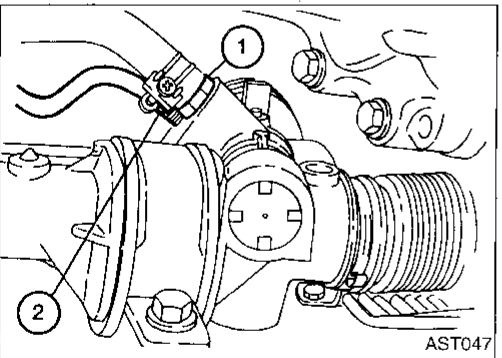

- Install lines.
- The O-ring in the low-pressure line ① is larger than that in the high-pressure line ②. Take care to install the proper O-ring.
- Observe specified tightening torque when tightening high-pressure and low-pressure line flare nuts. Excessive tightening can damage threads or O-rings.

Low-pressure side "①":

: 27 - 39 N·m (2.8 - 4.0 kg-m, 20 - 29 ft-lb)

High-pressure side "②":

: 15 - 25 N·m (1.5 - 2.5 kg-m, 11 - 18 ft-lb)

- Tighten gear housing mounting bracket bolts in the order shown.

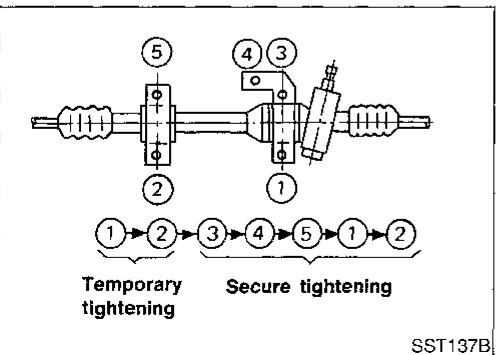

POWER STEERING GEAR AND LINKAGE

Description

SEC. 492

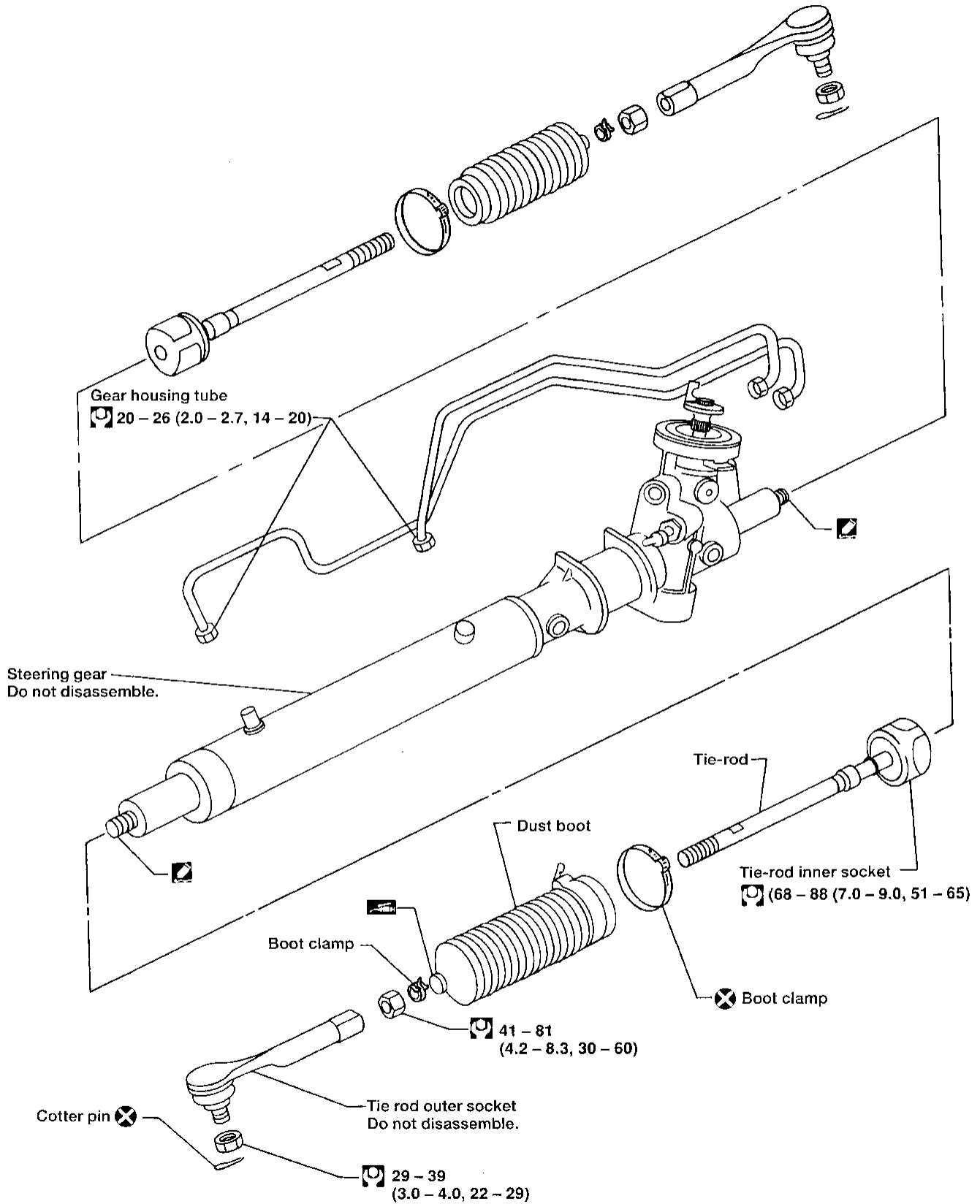

\square : N·m (kg·m, ft·lb)

\otimes : Always replace after every disassembly.

POWER STEERING GEAR AND LINKAGE

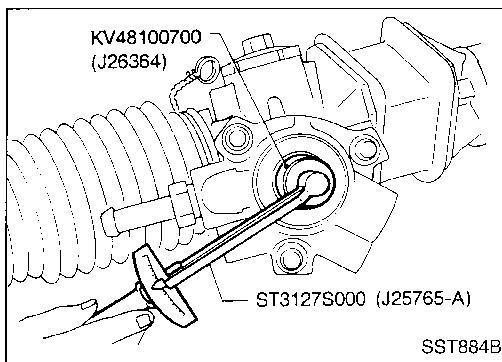

Disassembly

1. Prior to disassembling, measure pinion rotating torque.

Within $\pm 100^\circ$ from the neutral position:

Average rotating torque

0.5 - 1.4 N·m (5 - 14 kg-cm, 4.3 - 12.2 in-lb)

Maximum torque deviation

0.4 N·m (4 kg-cm, 3.5 in-lb)

Except for above measuring range:

Maximum rotating torque

1.9 N·m (19 kg-cm, 16 in-lb)

Maximum force deviation

0.6 N·m (6 kg-cm, 5.2 in-lb)

- If pinion rotating torque is not within specifications, replace steering gear assembly.
- Before measuring, disconnect gear housing tube and drain fluid.
- Use soft jaws when holding steering gear housing. Handle gear housing carefully, as it is made of aluminum. Do not grip cylinder in a vise.

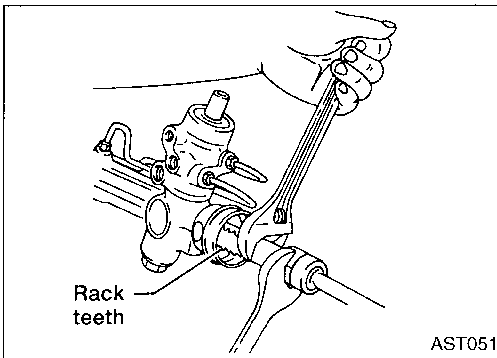

2. Remove tie-rod outer sockets and boots.
3. Remove tie-rod inner sockets.

Inspection

Thoroughly clean all parts in cleaning solvent or Type F Automatic Transmission Fluid or equivalent. Blow dry with compressed air, if available.

BOOT

- Check condition of boots. If cracked excessively, replace.
- Check boots for accumulation of power steering fluid.

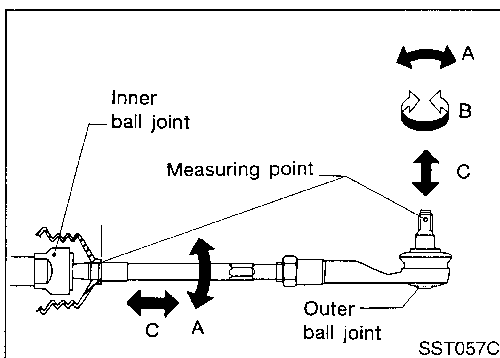

TIE-ROD OUTER AND INNER SOCKET

- Check outer and inner ball joints for swing force "A" and axial end play "C".
Refer to SDS, ST-23.
- Check outer ball joint for rotating torque "B".
Refer to SDS, ST-23.
- Check condition of dust cover. If excessively cracked, replace outer tie-rod.

POWER STEERING GEAR AND LINKAGE

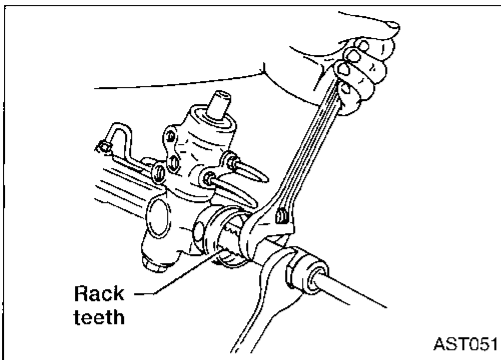

Assembly

1. Install tie-rod inner sockets, dust boots and outer sockets.
 - Apply locking sealant to inner socket threads.

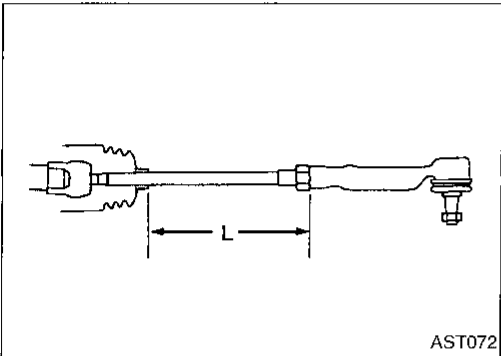

2. Tighten outer socket lock nut.
Tie-rod length "L":
Refer to ST-23.

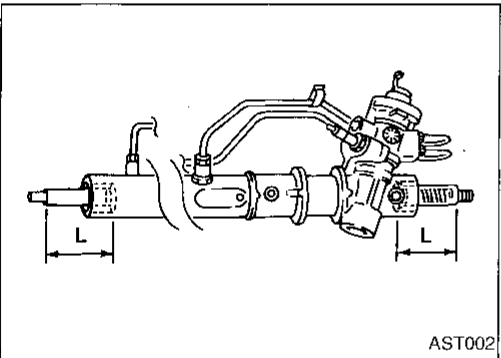

3. Measure rack stroke.
Rack stroke "L":
Refer to ST-24.

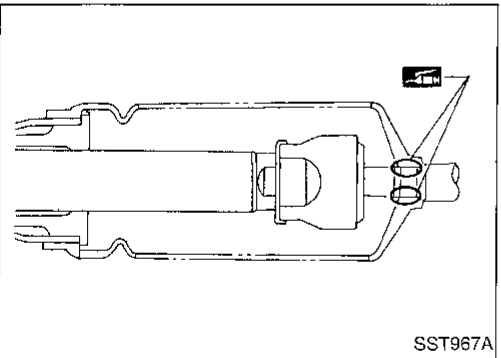

4. Before installing boot, coat the contact surfaces between boot and tie-rod with grease.

POWER STEERING GEAR AND LINKAGE

Assembly (Cont'd)

5. Install boot clamps.
 - Install large boot clamp using suitable tool and crimp securely.
 - Install small boot clamp as shown.

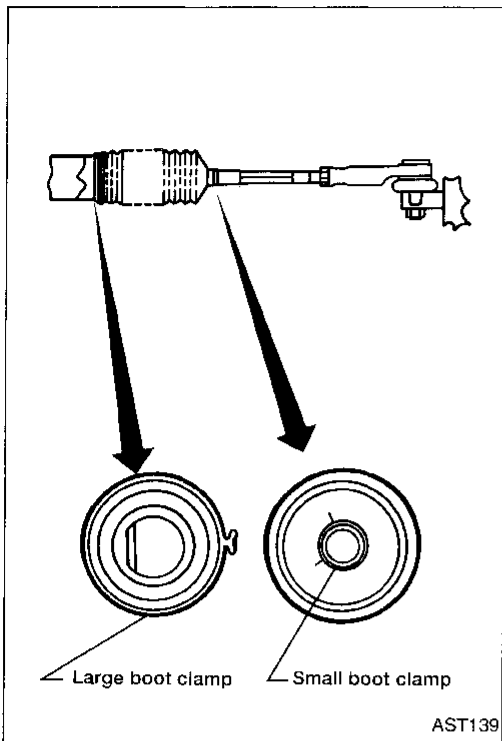

GI

MA

EM

LC

EC

FE

AT

FA

FA

BR

ST

RS

BT

HA

EL

IDX

POWER STEERING OIL PUMP

SEC. 490

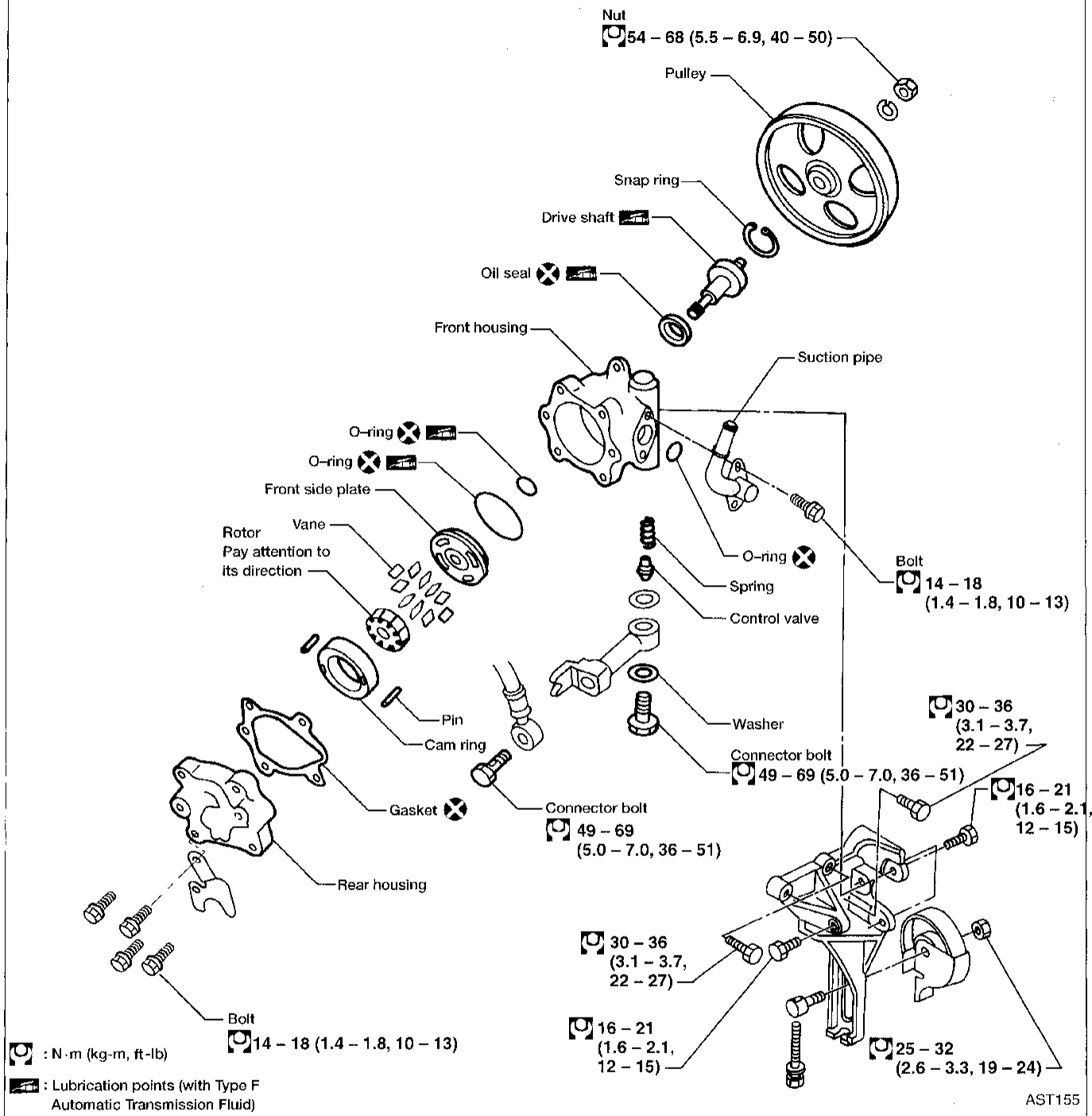

AST155

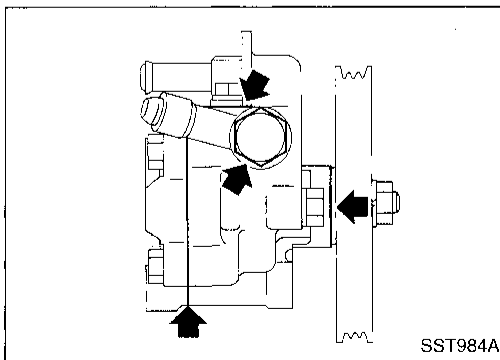

Pre-disassembly Inspection

Disassemble the power steering pump only if the following items are found.

- Fluid leak from any point shown in the figure.
- Deformed or damaged pulley.

POWER STEERING OIL PUMP

Inspection

PULLEY AND PULLEY SHAFT

- If pulley is cracked or deformed, replace it.
- If fluid leak is found around the pulley shaft oil seal, replace the seal.

Disassembly

CAUTION:

- Parts which can be serviced are strictly limited.
- Disassemble in as clean a place as possible.
- Clean your hands before disassembly.
- Do not use rags; use nylon cloths or paper towels.
- When disassembling and reassembling, do not let foreign matter enter or contact the parts.

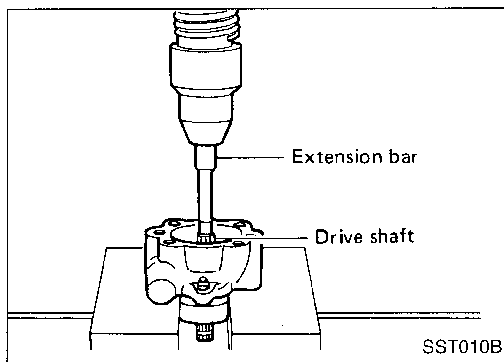

- Remove snap ring, then draw drive shaft out.
- Be careful not to drop drive shaft.

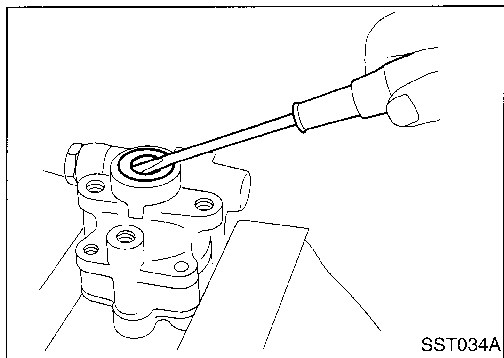

- Remove oil seal.
- Be careful not to damage front housing.

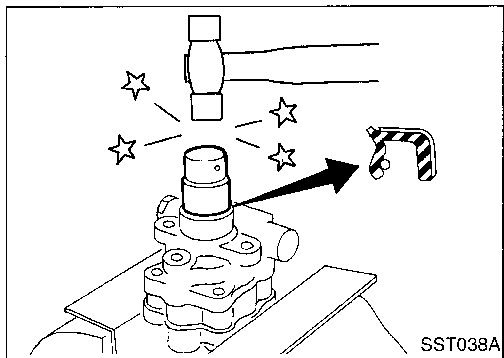

Assembly

Assemble power steering pump, noting the following instructions.

- Make sure O-rings and oil seal are properly installed.
- Always install new O-rings and oil seal.
- Be careful of oil seal direction.
- Coat each part with Type F Automatic Transmission Fluid when assembling.

POWER STEERING OIL PUMP

Assembly (Cont'd)

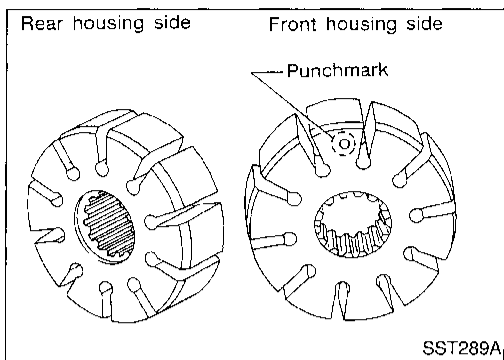

- Pay attention to the direction of rotor.

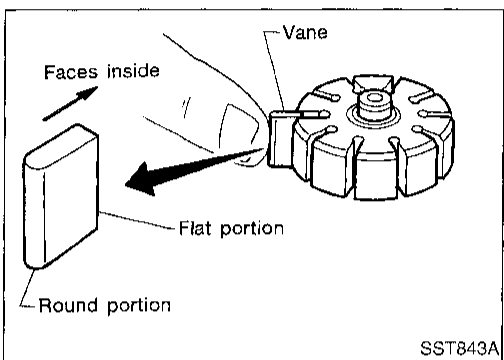

- When assembling vanes to rotor, rounded surfaces of vanes must face cam ring side.

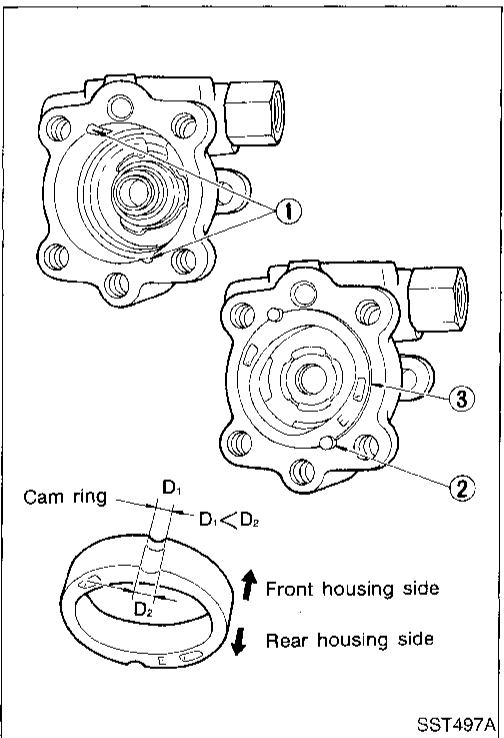

- Insert pin ② into pin groove ① of front housing and front side plate. Then install cam ring ③ as shown at left.

Cam ring:

D_1 is less than D_2

SERVICE DATA AND SPECIFICATIONS (SDS)

General Specifications

Applied model	All
Steering model	Power steering (TRW)
Steering gear type	PR28T
Turns of steering wheel (Lock to lock)	3.0
Steering column type	Collapsible, tilt

Inspection and Adjustment

GENERAL

Steering wheel axial play mm (in)	0 (0)
Steering wheel play mm (in)	35 (1.38) or less
Movement of gear housing mm (in)	±2 (±0.08) or less

STEERING COLUMN

Steering column length "L" mm (in)	505.5 - 507.1 (19.90 - 19.96)
---------------------------------------	-------------------------------

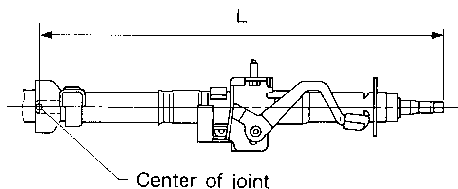

SST334C

STEERING GEAR AND LINKAGE

Steering gear type	PR28T
Tie-rod outer ball joint Swinging force "A" at cotter pin hole N (kg, lb)	2.0 - 137.3 (0.2 - 14, 0.4 - 30.9)
Rotating torque "B" N-m (kg-cm, in-lb)	0.15 - 6.22 (1.5 - 63.4, 1.3 - 55.0)
Tie-rod inner ball joint Swinging force* "A" N (kg, lb)	0.20 - 215.8 (0.02 - 22, 0.04 - 48.5)
Axial end play limit "C" mm (in)	0.4 (0.016)
Tie-rod standard length "L" mm (in)	
RH side	205.1 (8.07)
LH side	182.7 (7.19)

*: Measuring point at outside end of boot

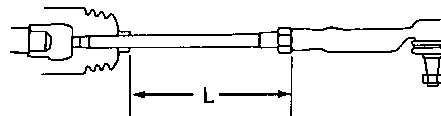

AST072

SERVICE DATA AND SPECIFICATIONS (SDS)

Inspection and Adjustment (Cont'd)

STEERING GEAR AND LINKAGE (Cont'd)

Steering gear type	PR28T
Rack stroke "L" mm (in)	72 (2.83)

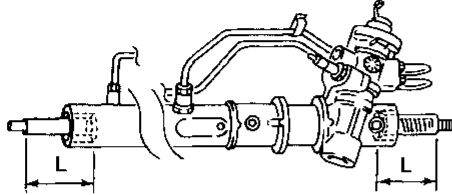

AST002

Pinion gear preload without gear oil N·m (kg-cm, in-lb)	
Within $\pm 100^\circ$ from the neutral position	
Average rotating torque	0.5 - 1.4 (5 - 14, 4.3 - 12.2)
Maximum torque deviation	0.4 (4, 3.5)
Except above range	
Maximum rotating torque	1.9 (19, 16)
Maximum torque deviation	0.6 (6, 5.2)

POWER STEERING

Rack sliding force Under normal operating oil pressure	N (kg, lb)	
Range within ± 11.5 mm (± 0.453 in) from the neutral position		108-284 (11 - 29, 24 - 64)
Except above range		Not more than 324 (33, 73)
Steering wheel turning force (Measured at one full turn from the neutral position)	N (kg, lb)	39 (4, 9) or less
Fluid capacity (Approximate) l (US qt, Imp qt)		1.1 (1-1/8, 1)
Oil pump maximum pressure kPa (kg/cm ² , psi)		7,355 - 8,336 (75 - 85, 1,067 - 1,209)