A

ACC

ACC

C

D

E

F

G

H

I

J

K

L

M

N

O

P

SECTION **ACC**

ACCELERATOR CONTROL SYSTEM

CONTENTS

PRECAUTION	2	ACCELERATOR CONTROL SYSTEM	3
PRECAUTIONS	2	Component	3
Precaution for Supplemental Restraint System (SRS) "AIR BAG" and "SEAT BELT PRE-TEN- SIONER"	2	Removal and Installation	4
Precaution Necessary for Steering Wheel Rota- tion After Battery Disconnect	2	SERVICE DATA AND SPECIFICATIONS (SDS)	6
REMOVAL AND INSTALLATION	3	SERVICE DATA AND SPECIFICATIONS (SDS)	6
		Accelerator Control	6

PRECAUTIONS

< PRECAUTION >

PRECAUTION

PRECAUTIONS

Precaution for Supplemental Restraint System (SRS) "AIR BAG" and "SEAT BELT PRE-TENSIONER"

INFOID:000000003938679

The Supplemental Restraint System such as "AIR BAG" and "SEAT BELT PRE-TENSIONER", used along with a front seat belt, helps to reduce the risk or severity of injury to the driver and front passenger for certain types of collision. This system includes seat belt switch inputs and dual stage front air bag modules. The SRS system uses the seat belt switches to determine the front air bag deployment, and may only deploy one front air bag, depending on the severity of a collision and whether the front occupants are belted or unbelted. Information necessary to service the system safely is included in the SR and SB section of this Service Manual.

WARNING:

- To avoid rendering the SRS inoperative, which could increase the risk of personal injury or death in the event of a collision which would result in air bag inflation, all maintenance must be performed by an authorized NISSAN/INFINITI dealer.
- Improper maintenance, including incorrect removal and installation of the SRS, can lead to personal injury caused by unintentional activation of the system. For removal of Spiral Cable and Air Bag Module, see the SR section.
- Do not use electrical test equipment on any circuit related to the SRS unless instructed to in this Service Manual. SRS wiring harnesses can be identified by yellow and/or orange harnesses or harness connectors.

Precaution Necessary for Steering Wheel Rotation After Battery Disconnect

INFOID:000000004448866

NOTE:

- This Procedure is applied only to models with Intelligent Key system and NATS (NISSAN ANTI-THEFT SYSTEM).
- Remove and install all control units after disconnecting both battery cables with the ignition knob in the "LOCK" position.
- Always use CONSULT-III to perform self-diagnosis as a part of each function inspection after finishing work. If DTC is detected, perform trouble diagnosis according to self-diagnostic results.

For models equipped with the Intelligent Key system and NATS, an electrically controlled steering lock mechanism is adopted on the key cylinder.

For this reason, if the battery is disconnected or if the battery is discharged, the steering wheel will lock and steering wheel rotation will become impossible.

If steering wheel rotation is required when battery power is interrupted, follow the procedure below before starting the repair operation.

OPERATION PROCEDURE

1. Connect both battery cables.

NOTE:

Supply power using jumper cables if battery is discharged.

2. Use the Intelligent Key or mechanical key to turn the ignition switch to the "ACC" position. At this time, the steering lock will be released.
3. Disconnect both battery cables. The steering lock will remain released and the steering wheel can be rotated.
4. Perform the necessary repair operation.
5. When the repair work is completed, return the ignition switch to the "LOCK" position before connecting the battery cables. (At this time, the steering lock mechanism will engage.)
6. Perform a self-diagnosis check of all control units using CONSULT-III.

ACCELERATOR CONTROL SYSTEM

< REMOVAL AND INSTALLATION >

REMOVAL AND INSTALLATION

ACCELERATOR CONTROL SYSTEM

Component

INFOID:000000003938680

A

ACC

Adjustable Accelerator Pedal

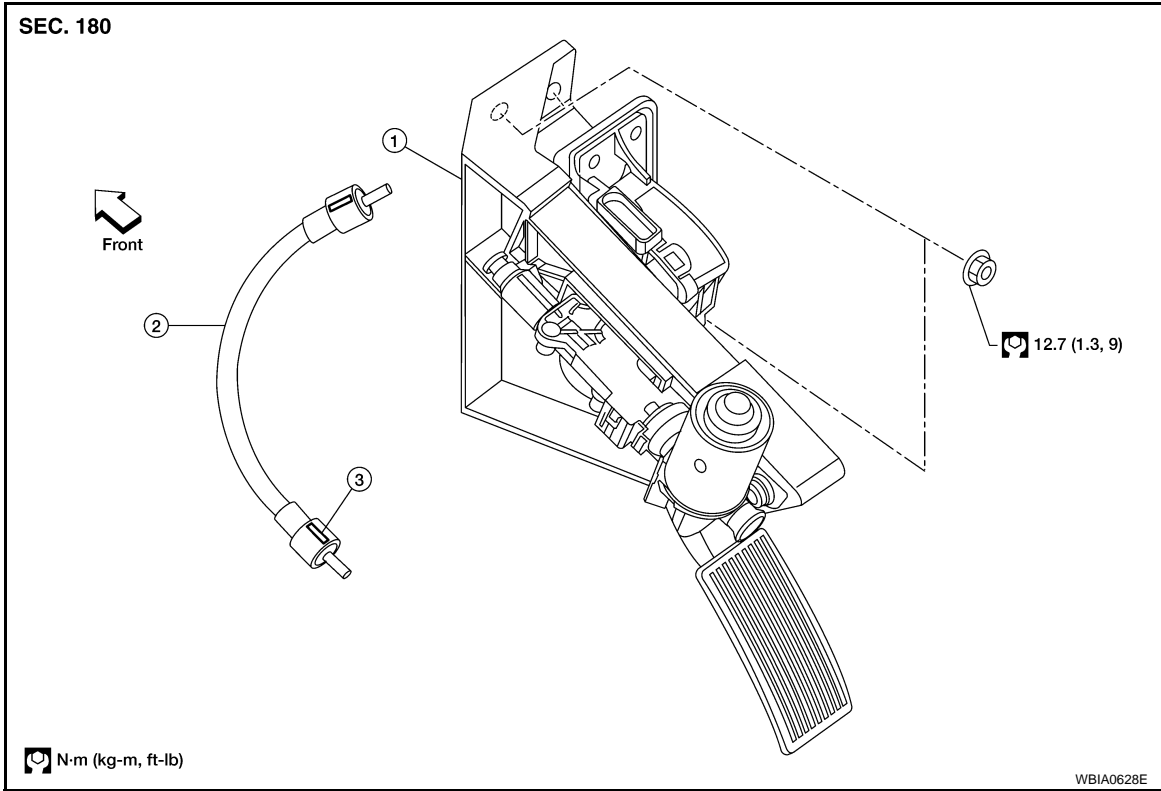

1. Adjustable accelerator pedal assembly
2. Adjustable brake pedal cable
3. Adjustable brake pedal cable lock tab (part of the cable)

C

D

E

F

G

H

I

J

K

L

M

N

O

P

ACCELERATOR CONTROL SYSTEM

< REMOVAL AND INSTALLATION >

Non-adjustable Accelerator Pedal

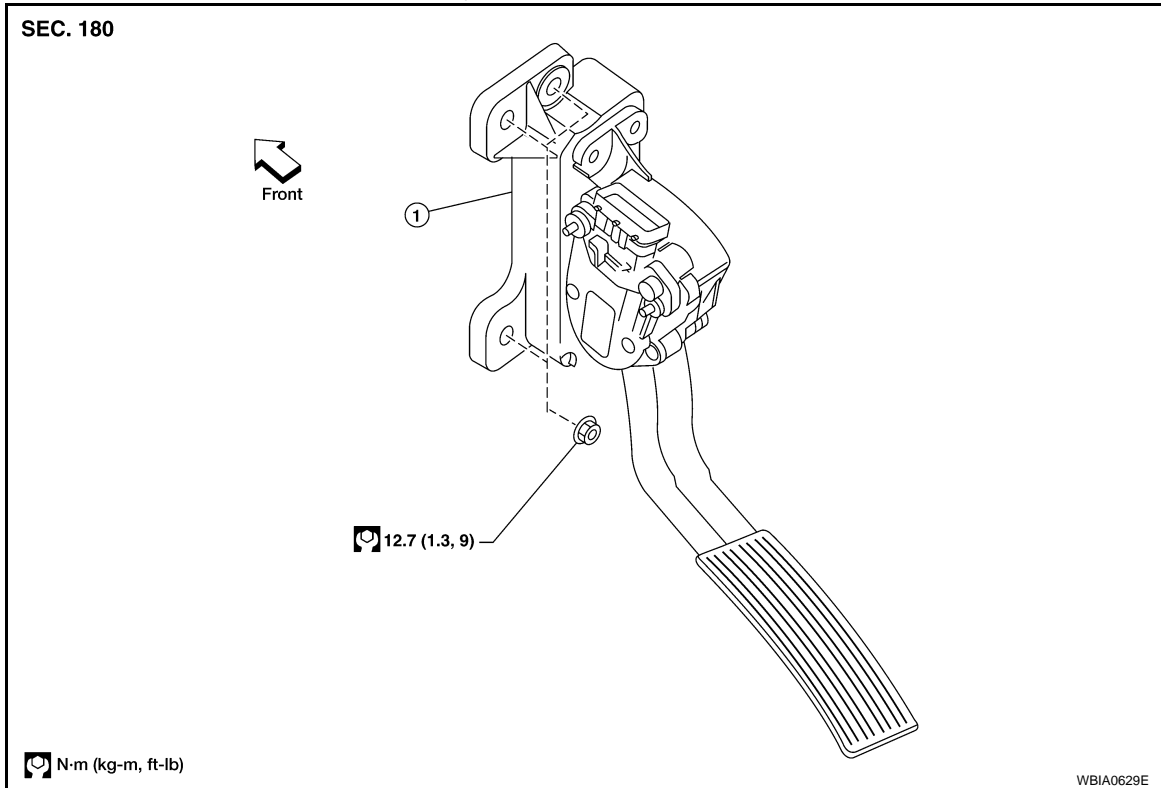

1. Non-adjustable accelerator pedal assembly

CAUTION:

- Before removal and installation, the adjustable accelerator and brake pedals must be in the frontmost position, if equipped. This is to align the base position of the accelerator and brake pedals.
- Do not disassemble the accelerator pedal assembly.
- Do not remove the accelerator pedal position sensor from the accelerator pedal bracket.
- Do not disassemble the accelerator pedal adjusting mechanism.
- Avoid damage from dropping the accelerator pedal assembly during handling.
- Keep the accelerator pedal assembly away from water.

Removal and Installation

INFOID:000000003938681

REMOVAL FOR ADJUSTABLE ACCELERATOR PEDAL

1. Move the accelerator and brake pedals to the frontmost position.
2. Turn the ignition switch OFF and disconnect the negative battery terminal.
3. Disconnect the adjustable pedal electric motor electrical connector.
4. Disconnect the adjustable pedal electric motor memory electrical connector, if equipped.
5. Disconnect the accelerator position sensor electrical connector.
 - a. Pull the connector lock back to unlock the connector from the accelerator pedal position sensor as shown.
 - b. Pull up on the connector to disconnect it from the accelerator pedal position sensor as shown.

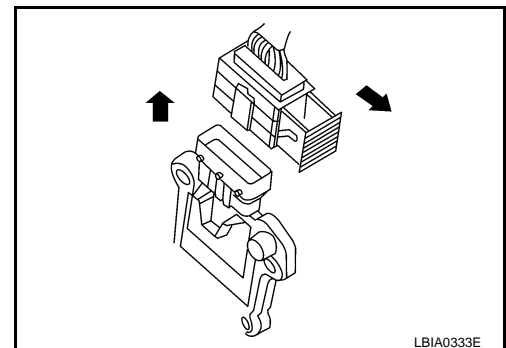

ACCELERATOR CONTROL SYSTEM

< REMOVAL AND INSTALLATION >

6. Disconnect the adjustable brake pedal cable from the adjustable accelerator pedal.
 - Release the two lock tabs, then pull the adjustable brake pedal cable to disconnect it from the adjustable accelerator pedal.

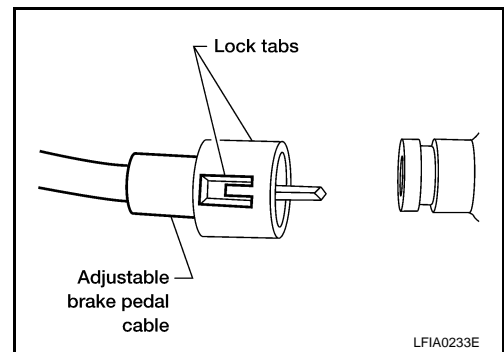

7. Remove the two upper and one lower accelerator pedal nuts.
8. Remove the adjustable accelerator pedal assembly.

CAUTION:

 - Do not disassemble the accelerator pedal assembly.
 - Do not remove the accelerator pedal position sensor from the accelerator pedal bracket.
 - Do not disassemble the accelerator pedal adjusting mechanism.
 - Avoid damage from dropping the accelerator pedal assembly during handling.
 - Keep the accelerator pedal assembly away from water.

REMOVAL FOR NON-ADJUSTABLE ACCELERATOR PEDAL

1. Disconnect the negative battery terminal.
2. Disconnect the accelerator position sensor electrical connector.
 - a. Pull the connector lock back to unlock the connector from the accelerator pedal position sensor as shown.
 - b. Pull up on the connector to disconnect it from the accelerator pedal position sensor as shown.
3. Remove the two upper and one lower accelerator pedal nuts.
4. Remove the accelerator pedal assembly.

CAUTION:

- Do not disassemble the accelerator pedal assembly.
- Do not remove the accelerator pedal position sensor from the accelerator pedal bracket.
- Avoid damage from dropping the accelerator pedal assembly during handling.
- Keep the accelerator pedal assembly away from water.

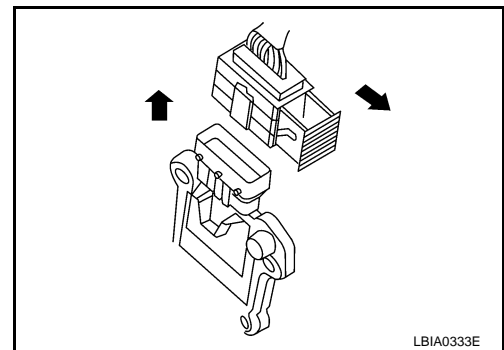

INSTALLATION

Installation is in the reverse order of removal.

INSPECTION AFTER INSTALLATION

- Check that the accelerator pedal moves smoothly within the specified range.

Accelerator pedal - total pedal applied stroke "A" : 48 mm (1.89 in)

- Check that the accelerator pedal smoothly returns to the original position.
- Perform an electrical inspection of the accelerator pedal position sensor. Refer to [EC-379, "Component Inspection"](#) (VQ40DE), [EC-851, "Component Inspection"](#) (VK56DE).

CAUTION:

When the harness connector of the accelerator pedal position sensor is disconnected, perform "Accelerator Pedal Released Position Learning". Refer to [EC-500, "Accelerator Pedal Released Position Learning"](#).

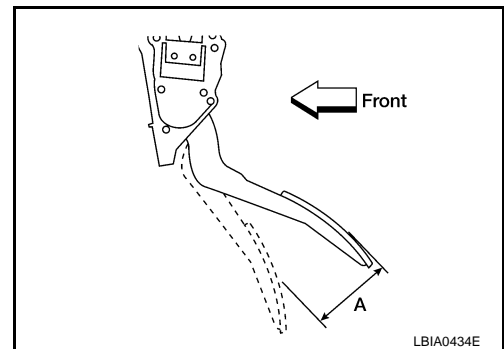

SERVICE DATA AND SPECIFICATIONS (SDS)

< SERVICE DATA AND SPECIFICATIONS (SDS)

SERVICE DATA AND SPECIFICATIONS (SDS)

SERVICE DATA AND SPECIFICATIONS (SDS)

Accelerator Control

INFOID:000000003938682

ADJUSTABLE AND NON-ADJUSTABLE ACCELERATOR PEDAL

Unit: mm (in)

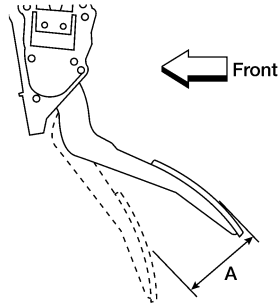

LBIA0434E

Accelerator pedal - total pedal applied stroke "A"	48 (1.89)
----------------------------------------------------	-----------