

SECTION **SE**
SEAT

A
B
C
D
E
F
G
H
I
SE
K
L
M
N
O
P

CONTENTS

SERVICE INFORMATION	2	PREPARATION	23
SQUEAK AND RATTLE TROUBLE DIAG- NOSES	2	PREPARATION	23
Work Flow	2	Special Service Tool	23
Generic Squeak and Rattle Troubleshooting	4	Commercial Service Tool	23
Diagnostic Worksheet	6	ON-VEHICLE REPAIR	24
COMPONENT DIAGNOSIS	8	FRONT SEAT	24
POWER SEAT	8	Exploded View	24
Wiring Diagram — Driver Side —	8	Removal and Installation	29
Wiring Diagram — Passenger Side —	12	REAR SEAT	30
HEATED SEAT	16	Removal and Installation	30
Description	16	DISASSEMBLY AND ASSEMBLY	32
Wiring Diagram	17	FRONT SEAT	32
PRECAUTION	22	Exploded View	32
PRECAUTIONS	22	Seatback Assembly	37
Precaution for Supplemental Restraint System (SRS) "AIR BAG" and "SEAT BELT PRE-TEN- SIONER"	22	Seat Cushion Trim and Pad	38
Precaution for Work	22	REAR SEAT	40
		Exploded View	40
		Disassembly and Assembly	40

SQUEAK AND RATTLE TROUBLE DIAGNOSES

< SERVICE INFORMATION >

SERVICE INFORMATION

SQUEAK AND RATTLE TROUBLE DIAGNOSES

Work Flow

INFOID:000000001303488

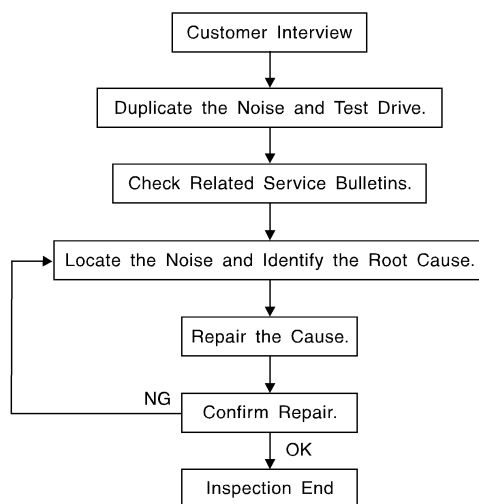

SBT842

CUSTOMER INTERVIEW

Interview the customer if possible, to determine the conditions that exist when the noise occurs. Use the Diagnostic Worksheet during the interview to document the facts and conditions when the noise occurs and any customer's comments; refer to [SE-6. "Diagnostic Worksheet"](#). This information is necessary to duplicate the conditions that exist when the noise occurs.

- The customer may not be able to provide a detailed description or the location of the noise. Attempt to obtain all the facts and conditions that exist when the noise occurs (or does not occur).
- If there is more than one noise in the vehicle, be sure to diagnose and repair the noise that the customer is concerned about. This can be accomplished by test driving the vehicle with the customer.
- After identifying the type of noise, isolate the noise in terms of its characteristics. The noise characteristics are provided so the customer, service adviser and technician are all speaking the same language when defining the noise.
- Squeak —(Like tennis shoes on a clean floor)
Squeak characteristics include the light contact/fast movement/brought on by road conditions/hard surfaces = higher pitch noise/softer surfaces = lower pitch noises/edge to surface = chirping.
- Creak—(Like walking on an old wooden floor)
Creak characteristics include firm contact/slow movement/twisting with a rotational movement/pitch dependent on materials/often brought on by activity.
- Rattle—(Like shaking a baby rattle)
Rattle characteristics include the fast repeated contact/vibration or similar movement/loose parts/missing clip or fastener/incorrect clearance.
- Knock —(Like a knock on a door)
Knock characteristics include hollow sounding/sometimes repeating/often brought on by driver action.
- Tick—(Like a clock second hand)
Tick characteristics include gentle contacting of light materials/loose components/can be caused by driver action or road conditions.
- Thump—(Heavy, muffled knock noise)
Thump characteristics include softer knock/dead sound often brought on by activity.
- Buzz—(Like a bumble bee)
Buzz characteristics include high frequency rattle/firm contact.
- Often the degree of acceptable noise level will vary depending upon the person. A noise that you may judge as acceptable may be very irritating to the customer.
- Weather conditions, especially humidity and temperature, may have a great effect on noise level.

DUPLICATE THE NOISE AND TEST DRIVE

SQUEAK AND RATTLE TROUBLE DIAGNOSES

< SERVICE INFORMATION >

If possible, drive the vehicle with the customer until the noise is duplicated. Note any additional information on the Diagnostic Worksheet regarding the conditions or location of the noise. This information can be used to duplicate the same conditions when you confirm the repair.

If the noise can be duplicated easily during the test drive, to help identify the source of the noise, try to duplicate the noise with the vehicle stopped by doing one or all of the following:

- 1) Close a door.
 - 2) Tap or push/pull around the area where the noise appears to be coming from.
 - 3) Rev the engine.
 - 4) Use a floor jack to recreate vehicle "twist".
 - 5) At idle, apply engine load (electrical load, half-clutch on M/T model, drive position on A/T model).
 - 6) Raise the vehicle on a hoist and hit a tire with a rubber hammer.
- Drive the vehicle and attempt to duplicate the conditions the customer states exist when the noise occurs.
 - If it is difficult to duplicate the noise, drive the vehicle slowly on an undulating or rough road to stress the vehicle body.

CHECK RELATED SERVICE BULLETINS

After verifying the customer concern or symptom, check ASIST for Technical Service Bulletins (TSBs) related to that concern or symptom.

If a TSB relates to the symptom, follow the procedure to repair the noise.

LOCATE THE NOISE AND IDENTIFY THE ROOT CAUSE

1. Narrow down the noise to a general area. To help pinpoint the source of the noise, use a listening tool (Chassis Ear: J-39570, Engine Ear: J-39565 and mechanic's stethoscope).
2. Narrow down the noise to a more specific area and identify the cause of the noise by:
 - removing the components in the area that you suspect the noise is coming from.
Do not use too much force when removing clips and fasteners, otherwise clips and fasteners can be broken or lost during the repair, resulting in the creation of new noise.
 - tapping or pushing/pulling the component that you suspect is causing the noise.
Do not tap or push/pull the component with excessive force, otherwise the noise will be eliminated only temporarily.
 - feeling for a vibration with your hand by touching the component(s) that you suspect is (are) causing the noise.
 - placing a piece of paper between components that you suspect are causing the noise.
 - looking for loose components and contact marks.
Refer to [SE-4, "Generic Squeak and Rattle Troubleshooting"](#).

REPAIR THE CAUSE

- If the cause is a loose component, tighten the component securely.
- If the cause is insufficient clearance between components:
 - separate components by repositioning or loosening and retightening the component, if possible.
 - insulate components with a suitable insulator such as urethane pads, foam blocks, felt cloth tape or urethane tape. A NISSAN Squeak and Rattle Kit (J-43980) is available through your authorized NISSAN Parts Department.

CAUTION:

Do not use excessive force as many components are constructed of plastic and may be damaged.

Always check with the Parts Department for the latest parts information.

The following materials are contained in the NISSAN Squeak and Rattle Kit (J-43980). Each item can be ordered separately as needed.

URETHANE PADS [1.5 mm (0.059 in) thick]

Insulates connectors, harness, etc.

76268-9E005: 100×135 mm (3.94×5.31 in)/76884-71L01: 60×85 mm (2.36×3.35 in)/76884-71L02: 15×25 mm (0.59×0.98 in)

INSULATOR (Foam blocks)

Insulates components from contact. Can be used to fill space behind a panel.

73982-9E000: 45 mm (1.77 in) thick, 50×50 mm (1.97×1.97 in)/73982-50Y00: 10 mm (0.39 in) thick, 50×50 mm (1.97×1.97 in)

INSULATOR (Light foam block)

80845-71L00: 30 mm (1.18 in) thick, 30×50 mm (1.18×1.97 in)

FELT CLOTH TAPE

Used to insulate where movement does not occur. Ideal for instrument panel applications.

SQUEAK AND RATTLE TROUBLE DIAGNOSES

< SERVICE INFORMATION >

68370-4B000: 15×25 mm (0.59×0.98 in) pad/68239-13E00: 5 mm (0.20 in) wide tape roll. The following materials not found in the kit can also be used to repair squeaks and rattles.

UHMW (TEFLON) TAPE

Insulates where slight movement is present. Ideal for instrument panel applications.

SILICONE GREASE

Used instead of UHMW tape that will be visible or not fit.

Note: Will only last a few months.

SILICONE SPRAY

Use when grease cannot be applied.

DUCT TAPE

Use to eliminate movement.

CONFIRM THE REPAIR

Confirm that the cause of a noise is repaired by test driving the vehicle. Operate the vehicle under the same conditions as when the noise originally occurred. Refer to the notes on the Diagnostic Worksheet.

Generic Squeak and Rattle Troubleshooting

INFOID:000000001303489

Refer to Table of Contents for specific component removal and installation information.

INSTRUMENT PANEL

Most incidents are caused by contact and movement between:

1. The cluster lid A and instrument panel
2. Acrylic lens and combination meter housing
3. Instrument panel to front pillar garnish
4. Instrument panel to windshield
5. Instrument panel mounting pins
6. Wiring harnesses behind the combination meter
7. A/C defroster duct and duct joint

These incidents can usually be located by tapping or moving the components to duplicate the noise or by pressing on the components while driving to stop the noise. Most of these incidents can be repaired by applying felt cloth tape or silicone spray (in hard to reach areas). Urethane pads can be used to insulate wiring harness.

CAUTION:

Do not use silicone spray to isolate a squeak or rattle. If you saturate the area with silicone, you will not be able to recheck the repair.

CENTER CONSOLE

Components to pay attention to include:

1. Shifter assembly cover to finisher
2. A/C control unit and cluster lid C
3. Wiring harnesses behind audio and A/C control unit

The instrument panel repair and isolation procedures also apply to the center console.

DOORS

Pay attention to the:

1. Finisher and inner panel making a slapping noise
2. Inside handle escutcheon to door finisher
3. Wiring harnesses tapping
4. Door striker out of alignment causing a popping noise on starts and stops

Tapping or moving the components or pressing on them while driving to duplicate the conditions can isolate many of these incidents. You can usually insulate the areas with felt cloth tape or insulator foam blocks from the NISSAN Squeak and Rattle Kit (J-43980) to repair the noise.

TRUNK

Trunk noises are often caused by a loose jack or loose items put into the trunk by the owner.

In addition look for:

1. Trunk lid bumpers out of adjustment

SQUEAK AND RATTLE TROUBLE DIAGNOSES

< SERVICE INFORMATION >

2. Trunk lid striker out of adjustment
3. The trunk lid torsion bars knocking together
4. A loose license plate or bracket

Most of these incidents can be repaired by adjusting, securing or insulating the item(s) or component(s) causing the noise.

SUNROOF/HEADLINING

Noises in the sunroof/headlining area can often be traced to one of the following:

1. Sunroof lid, rail, linkage or seals making a rattle or light knocking noise
2. Sun visor shaft shaking in the holder
3. Front or rear windshield touching headliner and squeaking

Again, pressing on the components to stop the noise while duplicating the conditions can isolate most of these incidents. Repairs usually consist of insulating with felt cloth tape.

OVERHEAD CONSOLE (FRONT AND REAR)

Overhead console noises are often caused by the console panel clips not being engaged correctly. Most of these incidents are repaired by pushing up on the console at the clip locations until the clips engage.

In addition look for:

1. Loose harness or harness connectors.
2. Front console map/reading lamp lense loose.
3. Loose screws at console attachment points.

SEATS

When isolating seat noise it's important to note the position the seat is in and the load placed on the seat when the noise is present. These conditions should be duplicated when verifying and isolating the cause of the noise.

Cause of seat noise include:

1. Headrest rods and holder
2. A squeak between the seat pad cushion and frame
3. The rear seatback lock and bracket

These noises can be isolated by moving or pressing on the suspected components while duplicating the conditions under which the noise occurs. Most of these incidents can be repaired by repositioning the component or applying urethane tape to the contact area.

UNDERHOOD

Some interior noise may be caused by components under the hood or on the engine wall. The noise is then transmitted into the passenger compartment.

Causes of transmitted underhood noise include:

1. Any component mounted to the engine wall
2. Components that pass through the engine wall
3. Engine wall mounts and connectors
4. Loose radiator mounting pins
5. Hood bumpers out of adjustment
6. Hood striker out of adjustment

These noises can be difficult to isolate since they cannot be reached from the interior of the vehicle. The best method is to secure, move or insulate one component at a time and test drive the vehicle. Also, engine RPM or load can be changed to isolate the noise. Repairs can usually be made by moving, adjusting, securing, or insulating the component causing the noise.

A
B
C
D
E
F
G
H
I
K
L
M
N
O
P

SE

SQUEAK AND RATTLE TROUBLE DIAGNOSES

< SERVICE INFORMATION >

Diagnostic Worksheet

INFOID:000000001303490

Dear Customer:

We are concerned about your satisfaction with your vehicle. Repairing a squeak or rattle sometimes can be very difficult. To help us fix your vehicle right the first time, please take a moment to note the area of the vehicle where the squeak or rattle occurs and under what conditions. You may be asked to take a test drive with a service advisor or technician to ensure we confirm the noise you are hearing.

SQUEAK & RATTLE DIAGNOSTIC WORKSHEET

I. WHERE DOES THE NOISE COME FROM? (circle the area of the vehicle)

The illustrations are for reference only, and may not reflect the actual configuration of your vehicle.

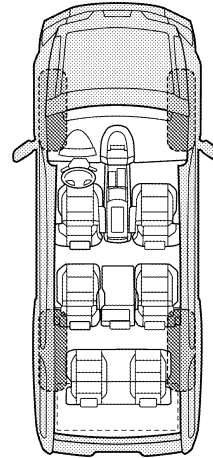
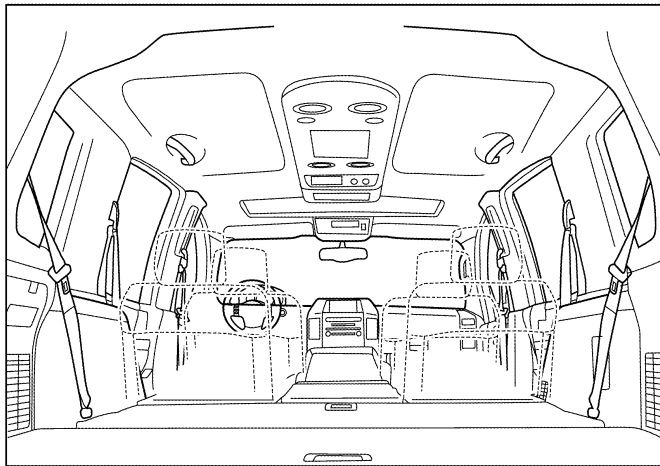
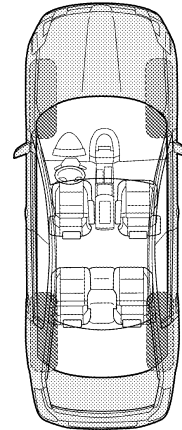
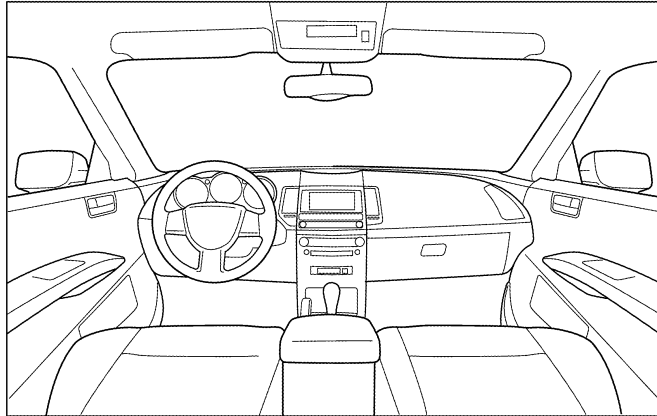

Continue to page 2 of the worksheet and briefly describe the location of the noise or rattle. In addition, please indicate the conditions which are present when the noise occurs.

SQUEAK AND RATTLE TROUBLE DIAGNOSES

< SERVICE INFORMATION >

SQUEAK & RATTLE DIAGNOSTIC WORKSHEET - page 2

Briefly describe the location where the noise occurs:

II. WHEN DOES IT OCCUR? (please check the boxes that apply)

- | | |
|---|--|
| <input type="checkbox"/> Anytime | <input type="checkbox"/> After sitting out in the rain |
| <input type="checkbox"/> 1st time in the morning | <input type="checkbox"/> When it is raining or wet |
| <input type="checkbox"/> Only when it is cold outside | <input type="checkbox"/> Dry or dusty conditions |
| <input type="checkbox"/> Only when it is hot outside | <input type="checkbox"/> Other: |

III. WHEN DRIVING:

- Through driveways
- Over rough roads
- Over speed bumps
- Only about ____ mph
- On acceleration
- Coming to a stop
- On turns: left, right or either (circle)
- With passengers or cargo
- Other: _____
- After driving ____ miles or ____ minutes

IV. WHAT TYPE OF NOISE

- Squeak (like tennis shoes on a clean floor)
- Creak (like walking on an old wooden floor)
- Rattle (like shaking a baby rattle)
- Knock (like a knock at the door)
- Tick (like a clock second hand)
- Thump (heavy muffled knock noise)
- Buzz (like a bumble bee)

TO BE COMPLETED BY DEALERSHIP PERSONNEL

Test Drive Notes:

	YES	NO	Initials of person performing
Vehicle test driven with customer	<input type="checkbox"/>	<input type="checkbox"/>	_____
- Noise verified on test drive	<input type="checkbox"/>	<input type="checkbox"/>	_____
- Noise source located and repaired	<input type="checkbox"/>	<input type="checkbox"/>	_____
- Follow up test drive performed to confirm repair	<input type="checkbox"/>	<input type="checkbox"/>	_____

VIN: _____ Customer Name _____

W.O.# _____ Date: _____

This form must be attached to Work Order

A
B
C
D
E
F
G
H
I
K
L
M
N
O
P

SE

POWER SEAT

< COMPONENT DIAGNOSIS >

COMPONENT DIAGNOSIS

POWER SEAT

Wiring Diagram — Driver Side —

INFOID:000000001714421

Ⓟ : WITH FRONT PASSENGER POWER SEAT

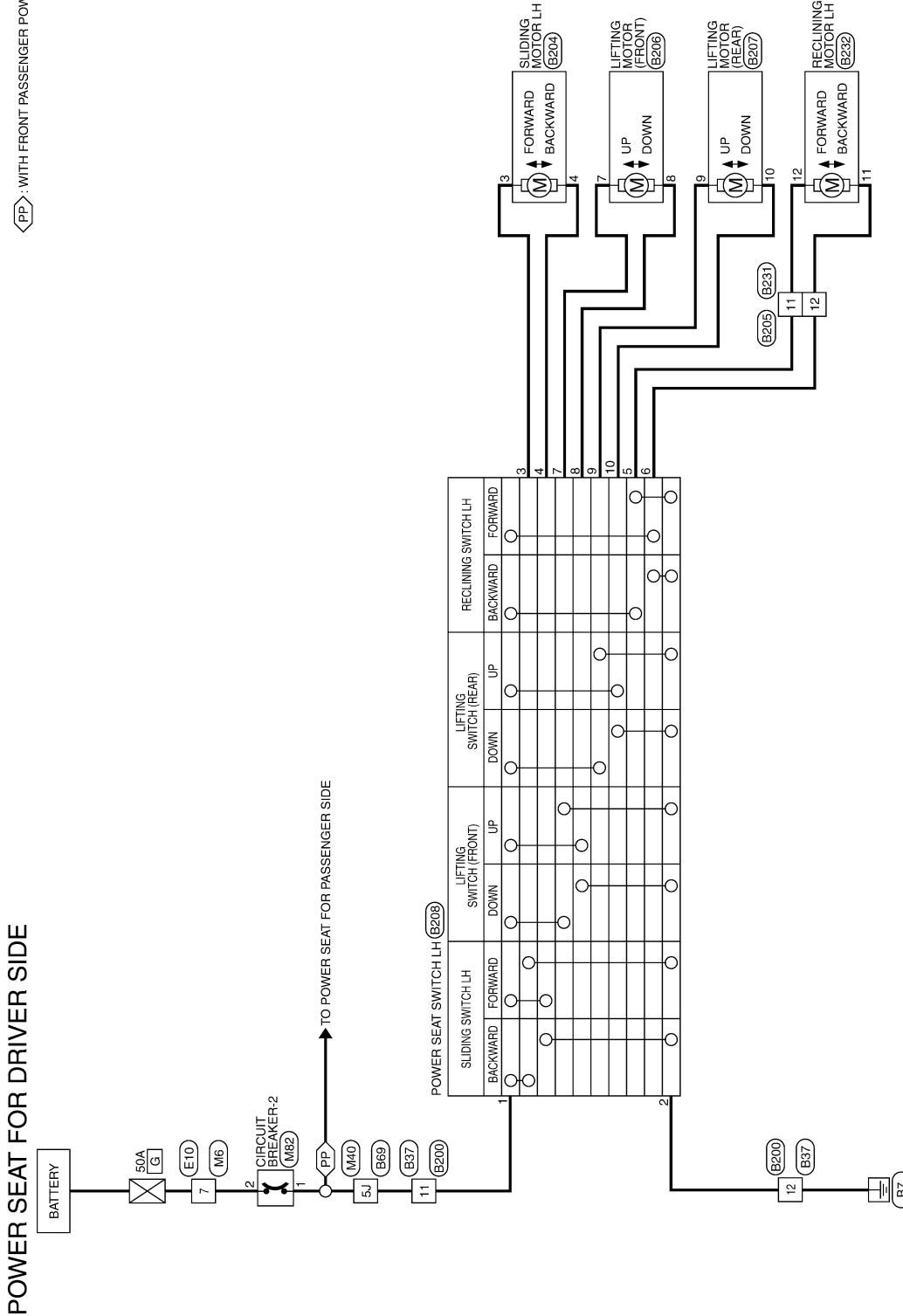

ALJWA0026GB

POWER SEAT FOR DRIVER SIDE CONNECTORS

Connector No.	M6
Connector Name	WIRE TO WIRE
Connector Color	WHITE

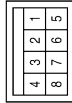

Terminal No.	Color of Wire	Signal Name
7	W	-

Connector No.	M40
Connector Name	WIRE TO WIRE
Connector Color	WHITE

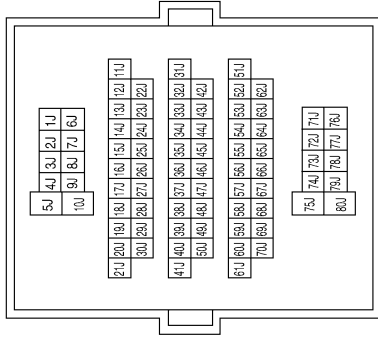

Terminal No.	Color of Wire	Signal Name
5J	G	-

Connector No.	M82
Connector Name	CIRCUIT BREAKER-2
Connector Color	WHITE



Terminal No.	Color of Wire	Signal Name
1	W	-
2	P	-

Connector No.	E10
Connector Name	WIRE TO WIRE
Connector Color	WHITE

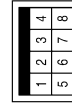

Terminal No.	Color of Wire	Signal Name
7	W	-

Connector No.	B37
Connector Name	WIRE TO WIRE
Connector Color	WHITE

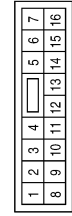

Terminal No.	Color of Wire	Signal Name
11	G	-
12	B	-

POWER SEAT

< COMPONENT DIAGNOSIS >

Connector No.	B69
Connector Name	WIRE TO WIRE
Connector Color	WHITE

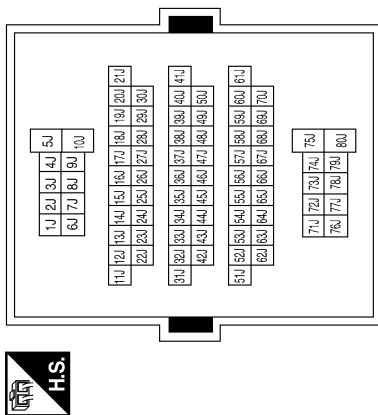

Terminal No.	Color of Wire	Signal Name
5J	G	-

Connector No.	B200
Connector Name	FRONT POWER SEAT LH
Connector Color	WHITE

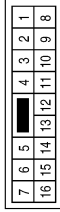

Terminal No.	Color of Wire	Signal Name
11	Y	POWER_SEAT_B
12	B	POWER_SEAT_GND

Connector No.	B204
Connector Name	SLIDING MOTOR LH
Connector Color	BLACK



Terminal No.	Color of Wire	Signal Name
3	R	-
4	G	-

Connector No.	B205
Connector Name	WIRE TO WIRE
Connector Color	GRAY



Terminal No.	Color of Wire	Signal Name
11	RW	-
12	G/W	-

Connector No.	B206
Connector Name	LIFTING MOTOR (FRONT)
Connector Color	WHITE



Terminal No.	Color of Wire	Signal Name
7	Y/B	-
8	Y	-

POWER SEAT

< COMPONENT DIAGNOSIS >

Connector No.	B207
Connector Name	LIFTING MOTOR (REAR)
Connector Color	GRAY



Terminal No.	Color of Wire	Signal Name
9	L	-
10	L/W	-

Connector No.	B208
Connector Name	FRONT POWER SEAT LH
Connector Color	WHITE

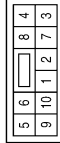

Terminal No.	Color of Wire	Signal Name
1	Y	-
2	R	-
3	R	-
4	G	-
5	R/W	-
6	G/W	-
7	Y/B	-
8	Y	-
9	L	-
10	L/W	-

Connector No.	B231
Connector Name	WIRE TO WIRE
Connector Color	GRAY



Terminal No.	Color of Wire	Signal Name
11	B/O	-
12	R/B	-

Connector No.	B232
Connector Name	RECLINING MOTOR LH
Connector Color	BROWN



Terminal No.	Color of Wire	Signal Name
11	R/B	-
12	B/O	-

A
B
C
D
E
F
G
H
I
SE
K
L
M
N
O
P

ALJIA0158GB

POWER SEAT

< COMPONENT DIAGNOSIS >

Wiring Diagram — Passenger Side —

INFOID:000000001714422

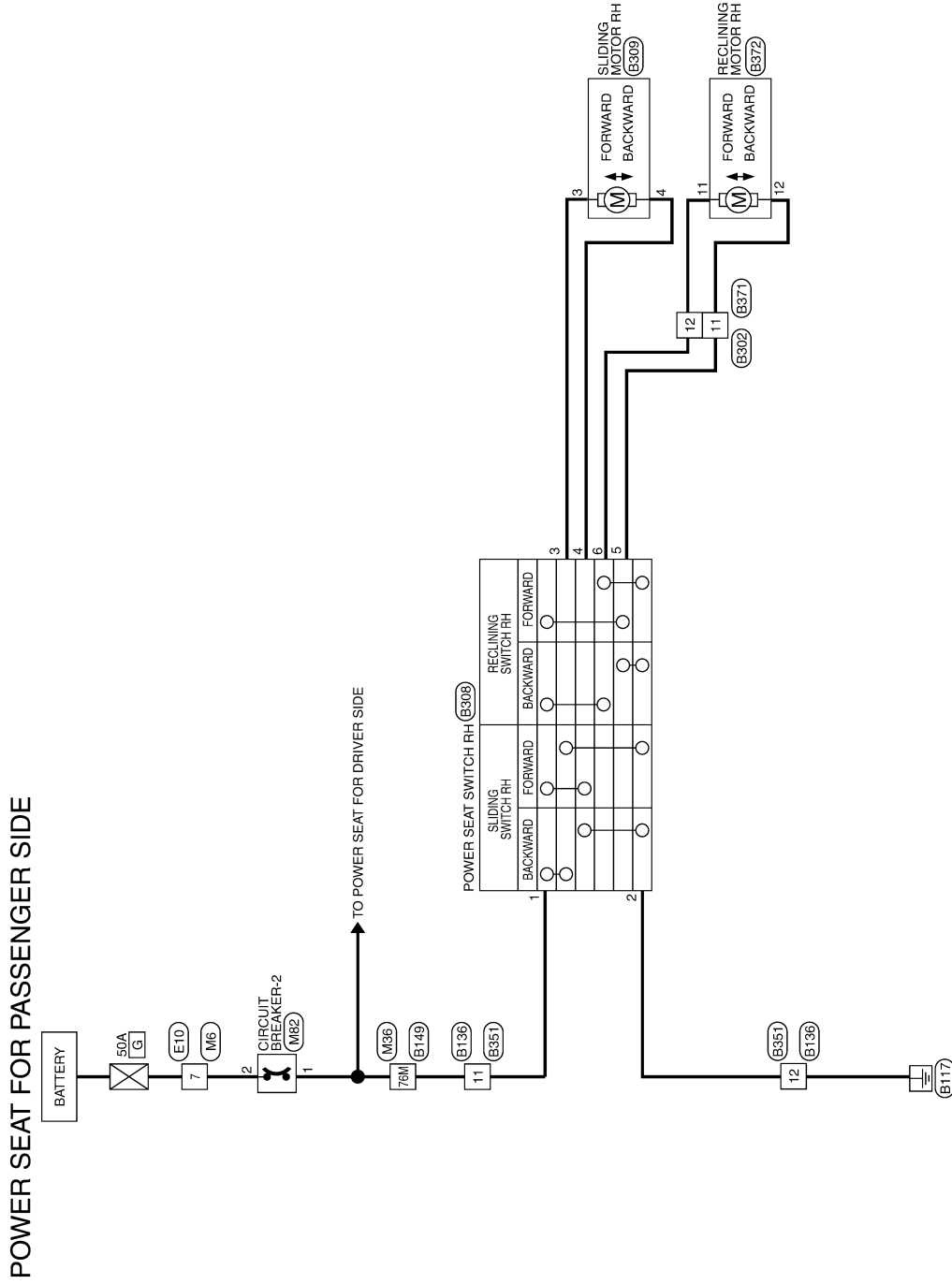

ALJWA0027GB

POWER SEAT FOR PASSENGER SIDE CONNECTORS

Connector No.	M6
Connector Name	WIRE TO WIRE
Connector Color	WHITE

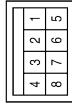

Terminal No.	Color of Wire	Signal Name
7	W	-

Connector No.	M36
Connector Name	WIRE TO WIRE
Connector Color	WHITE

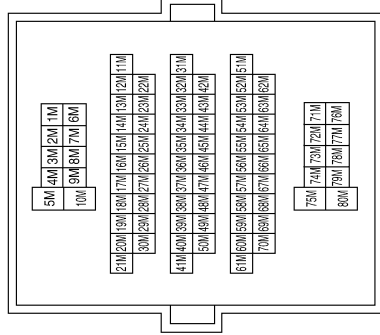

Terminal No.	76M	Color of Wire	LG	Signal Name	-
--------------	-----	---------------	----	-------------	---

Connector No.	M82
Connector Name	CIRCUIT BREAKER-2
Connector Color	WHITE



Terminal No.	Color of Wire	Signal Name
1	W	-
2	P	-

Connector No.	E10
Connector Name	WIRE TO WIRE
Connector Color	WHITE

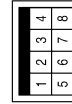

Terminal No.	7	Color of Wire	W	Signal Name	-
--------------	---	---------------	---	-------------	---

Connector No.	B136
Connector Name	WIRE TO WIRE
Connector Color	WHITE

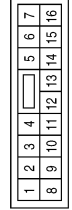

Terminal No.	11	Color of Wire	LG	Signal Name	-
	12	Color of Wire	B	Signal Name	-

A
B
C
D
E
F
G
H
I
SE
K
L
M
N
O
P

POWER SEAT

< COMPONENT DIAGNOSIS >

Connector No.	B149
Connector Name	WIRE TO WIRE
Connector Color	WHITE

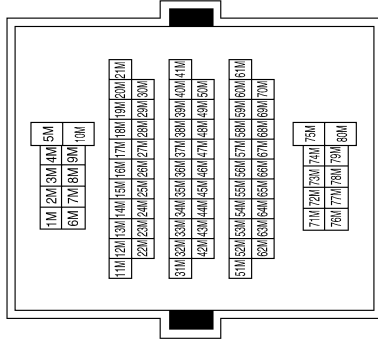

Terminal No.	Color of Wire	Signal Name
76M	LG	-

Connector No.	B302
Connector Name	WIRE TO WIRE
Connector Color	GRAY



Terminal No.	Color of Wire	Signal Name
11	R/W	-
12	G/W	-

Connector No.	B308
Connector Name	FRONT POWER SEAT RH
Connector Color	WHITE

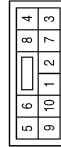

Connector No.	B309
Connector Name	SLIDING MOTOR RH
Connector Color	BLACK



Connector No.	B351
Connector Name	FRONT POWER SEAT RH
Connector Color	WHITE

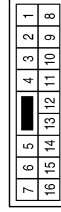

Terminal No.	Color of Wire	Signal Name
1	Y	-
2	R	-
3	R	-
4	G	-
5	R/W	-
6	G/W	-

Terminal No.	Color of Wire	Signal Name
3	R	-
4	G	-

Terminal No.	Color of Wire	Signal Name
11	Y	POWER_SEAT_B
12	R	POWER_SEAT_GND

POWER SEAT

< COMPONENT DIAGNOSIS >

Connector No.	B372
Connector Name	RECLINING MOTOR RH
Connector Color	WHITE



Terminal No.	Color of Wire	Signal Name
11	R/B	-
12	B/O	-

Connector No.	B371
Connector Name	WIRE TO WIRE
Connector Color	GRAY



Terminal No.	Color of Wire	Signal Name
11	B/O	-
12	R/B	-

- A
- B
- C
- D
- E
- F
- G
- H
- I
- SE**
- K
- L
- M
- N
- O
- P

ALJIA0161GB

HEATED SEAT

< COMPONENT DIAGNOSIS >

HEATED SEAT

Description

INFOID:000000001714439

- When handling seat, be extremely careful not to scratch heating unit (1).
- To replace heating unit for vehicles without side air bags, seat trim and pad should be separated. For vehicles equipped with side air bags, seat trim and pad should be separated for the front seat cushion LH. For seatback and front seat cushion RH, complete cushion (2) or seatback assembly (3) must be replaced.
- Do not use any organic solvent, such as thinner, benzene, alcohol, etc. to clean trim.

Thermostat operation	ON	OFF
Trim temperature °C (°F)	25 -35 (77 - 95)	35 - 45 (95 - 113)

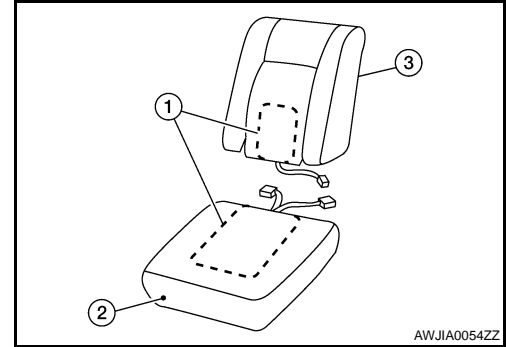

HEATED SEAT

< COMPONENT DIAGNOSIS >

Wiring Diagram

INFOID:000000001714424

HEATED SEAT

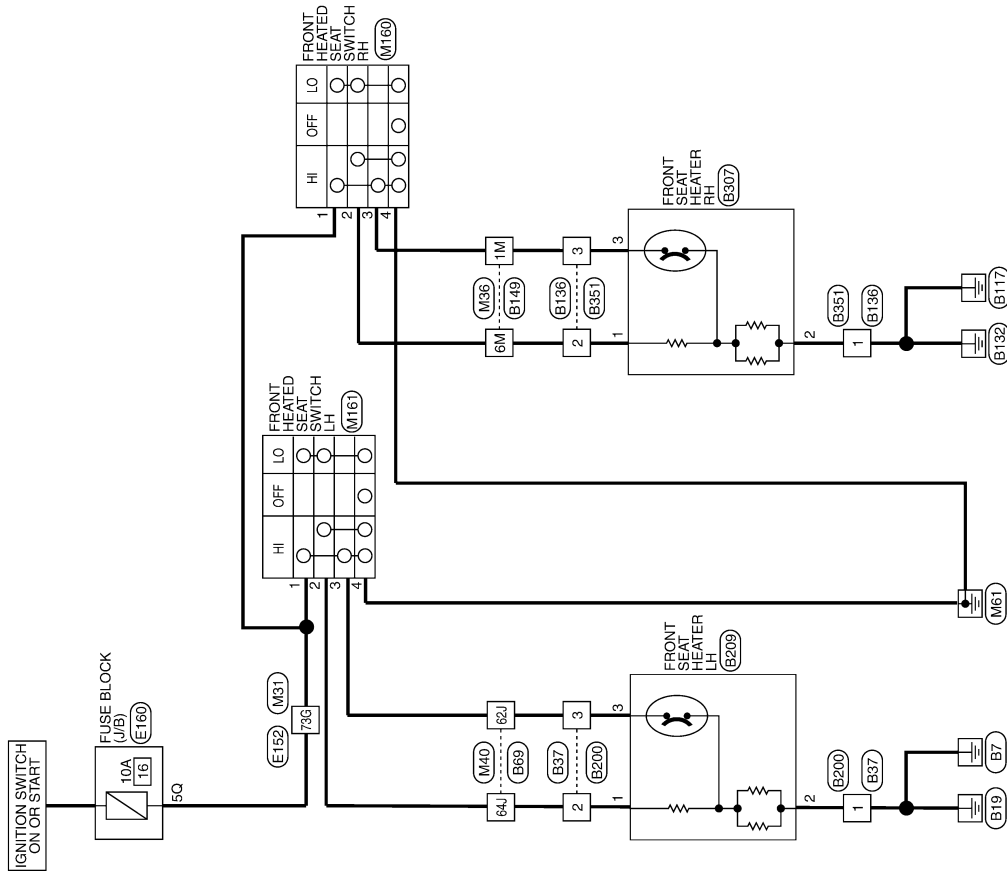

A
B
C
D
E
F
G
H
I
SE
K
L
M
N
O
P

ALJWA0028GB

HEATED SEAT

< COMPONENT DIAGNOSIS >

HEATED SEAT CONNECTORS

Connector No.	M31
Connector Name	WIRE TO WIRE
Connector Color	WHITE

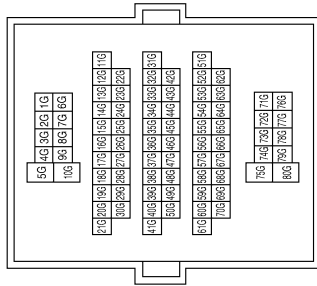

Terminal No.	Color of Wire	Signal Name
73G	W/R	-

Connector No.	M36
Connector Name	WIRE TO WIRE
Connector Color	WHITE

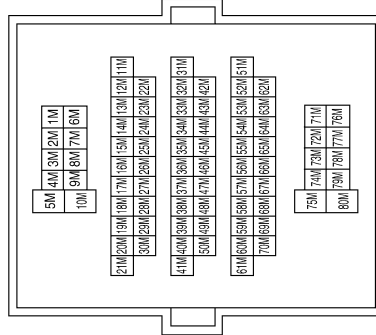

Terminal No.	Color of Wire	Signal Name
1M	GR	-
6M	W	-

ALJIA0162GB

HEATED SEAT

< COMPONENT DIAGNOSIS >

Connector No.	M40
Connector Name	WIRE TO WIRE
Connector Color	WHITE

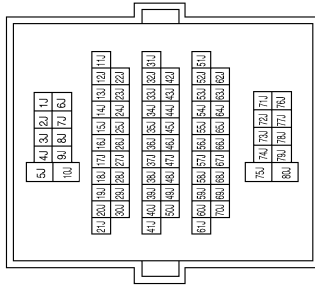

Terminal No.	Color of Wire	Signal Name
62J	LG	-
64J	GR	-

Connector No.	M160
Connector Name	FRONT HEATED SEAT SWITCH RH
Connector Color	BROWN



Terminal No.	Color of Wire	Signal Name
1	G	-
2	W	-
3	GR	-
4	B	-

Connector No.	M161
Connector Name	FRONT HEATED SEAT SWITCH LH
Connector Color	BROWN

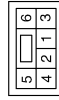

Terminal No.	Color of Wire	Signal Name
1	W/R	-
2	GR	-
3	LG	-
4	B	-

Connector No.	E152
Connector Name	WIRE TO WIRE
Connector Color	WHITE

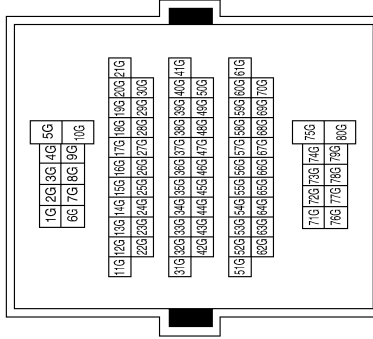

Terminal No.	Color of Wire	Signal Name
73G	W/R	-

A
B
C
D
E
F
G
H
I
SE
K
L
M
N
O
P

HEATED SEAT

< COMPONENT DIAGNOSIS >

Connector No.	E160
Connector Name	FUSE BLOCK (J/B)
Connector Color	WHITE

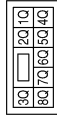

Terminal No.	Color of Wire	Signal Name
5Q	W/R	-

Connector No.	B37
Connector Name	WIRE TO WIRE
Connector Color	WHITE



Terminal No.	Color of Wire	Signal Name
1	B	-
2	GR	-
3	LG	-

Connector No.	B69
Connector Name	WIRE TO WIRE
Connector Color	WHITE

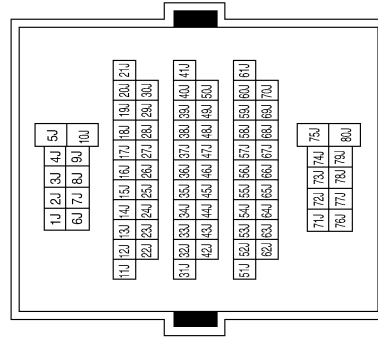

Terminal No.	Color of Wire	Signal Name
62J	LG	-
64J	GR	-

Connector No.	B136
Connector Name	WIRE TO WIRE
Connector Color	WHITE

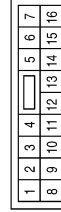

Terminal No.	Color of Wire	Signal Name
1	B	-
2	W	-
3	GR	-

ALJIA0164GB

HEATED SEAT

< COMPONENT DIAGNOSIS >

Connector No.	B149
Connector Name	WIRE TO WIRE
Connector Color	WHITE

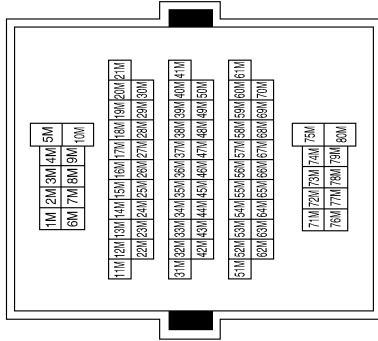

Terminal No.	Color of Wire	Signal Name
1M	GR	-
6M	W	-

Connector No.	B200
Connector Name	FRONT POWER SEAT LH
Connector Color	WHITE

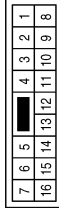

Terminal No.	Color of Wire	Signal Name
1	G/W	HEATED_SEAT_GND
2	Y	HEATED_SEAT_LO
3	Y/B	HEATED_SEAT_HI

Connector No.	B209
Connector Name	FRONT SEAT HEATER LH
Connector Color	WHITE



Terminal No.	Color of Wire	Signal Name
1	Y	-
2	G/W	-
3	Y/B	-

Connector No.	B307
Connector Name	FRONT SEAT HEATER RH
Connector Color	WHITE



Terminal No.	Color of Wire	Signal Name
1	Y	-
2	G/W	-
3	Y/B	-

Connector No.	B351
Connector Name	FRONT POWER SEAT RH
Connector Color	WHITE

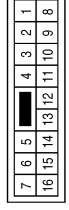

Terminal No.	Color of Wire	Signal Name
1	G/W	HEATER_GND
2	Y	HEATER_LO
3	Y/B	HEATER_HI

ALJIA0165GB

PRECAUTIONS

< PRECAUTION >

PRECAUTION

PRECAUTIONS

Precaution for Supplemental Restraint System (SRS) "AIR BAG" and "SEAT BELT PRE-TENSIONER"

INFOID:000000001303484

The Supplemental Restraint System such as "AIR BAG" and "SEAT BELT PRE-TENSIONER", used along with a front seat belt, helps to reduce the risk or severity of injury to the driver and front passenger for certain types of collision. This system includes seat belt switch inputs and dual stage front air bag modules. The SRS system uses the seat belt switches to determine the front air bag deployment, and may only deploy one front air bag, depending on the severity of a collision and whether the front occupants are belted or unbelted. Information necessary to service the system safely is included in the SR and SB section of this Service Manual.

WARNING:

- **To avoid rendering the SRS inoperative, which could increase the risk of personal injury or death in the event of a collision which would result in air bag inflation, all maintenance must be performed by an authorized NISSAN/INFINITI dealer.**
- **Improper maintenance, including incorrect removal and installation of the SRS, can lead to personal injury caused by unintentional activation of the system. For removal of Spiral Cable and Air Bag Module, see the SR section.**
- **Do not use electrical test equipment on any circuit related to the SRS unless instructed to in this Service Manual. SRS wiring harnesses can be identified by yellow and/or orange harnesses or harness connectors.**

Precaution for Work

INFOID:000000001303485

- When removing or disassembling each component, be careful not to damage or deform it. If a component may be subject to interference, be sure to protect it with a shop cloth.
- When removing (disengaging) components with a screwdriver or similar tool, be sure to wrap the component with a shop cloth or vinyl tape to protect it.
- Protect the removed parts with a shop cloth and keep them.
- Replace a deformed or damaged clip.
- If a part is specified as a non-reusable part, always replace it with new one.
- Be sure to tighten bolts and nuts securely to the specified torque.
- After re-installation is completed, be sure to check that each part works normally.
- Follow the steps below to clean components.
 - Water soluble foul: Dip a soft cloth into lukewarm water, and wring the water out of the cloth to wipe the fouled area.
Then rub with a soft and dry cloth.
 - Oily foul: Dip a soft cloth into lukewarm water with mild detergent (concentration: within 2 to 3%), and wipe the fouled area.
Then dip a cloth into fresh water, and wring the water out of the cloth to wipe the detergent off. Then rub with a soft and dry cloth.
- Do not use organic solvent such as thinner, benzene, alcohol, or gasoline.
- For genuine leather seats, use a genuine leather seat cleaner.

PREPARATION

< PREPARATION >

PREPARATION

PREPARATION

Special Service Tool

INFOID:000000001303486

The actual shapes of Kent-Moore tools may differ from those of special service tools illustrated here.

Tool number (Kent-Moore No.) Tool name	Description
— (J-39570) Chassis ear	Locating the noise
— (J-43980) NISSAN Squeak and Rattle Kit	Repairing the cause of noise

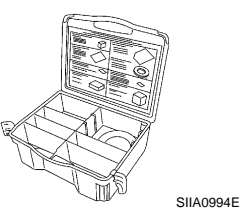
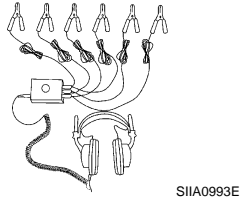

Commercial Service Tool

INFOID:000000001303487

(Kent-Moore No.) Tool name	Description
(J-39565) Engine ear	Locating the noise

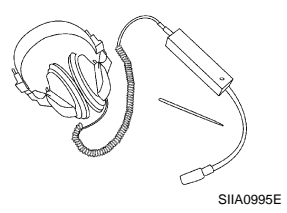

A
B
C
D
E
F
G
H
I
SE
K
L
M
N
O
P

FRONT SEAT

< ON-VEHICLE REPAIR >

ON-VEHICLE REPAIR

FRONT SEAT

Exploded View

INFOID:000000001303540

Power Driver Seat

SEC. 870

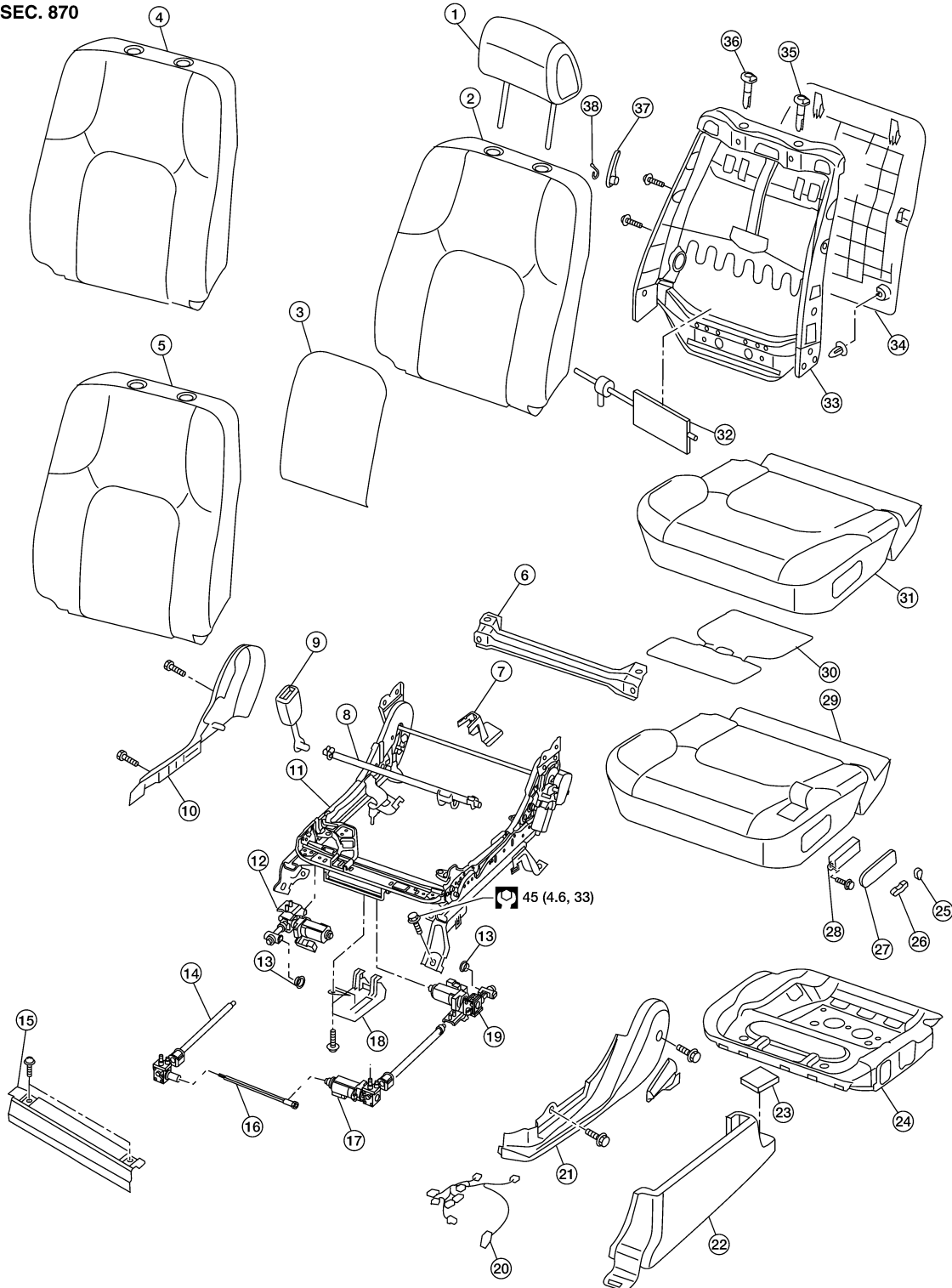

LIA2406E

FRONT SEAT

< ON-VEHICLE REPAIR >

1. Headrest	2. Seatback pad without side air bag	3. Seatback heating element	A
4. Seatback assembly with side air bag	5. Seatback trim without side air bag	6. Power seat cushion rear finisher	
7. Leg Cover	8. Lifter motor link bar	9. Seat belt buckle assembly	
10. Seat cushion inner finisher	11. Seat frame assembly	12. Seat lifter motor assembly	B
13. Seat spacer	14. Lock gear	15. Seat cushion front finisher	
16. Flexible seat wire	17. Front seat slide motor assembly (LH)	18. Power seat control assembly	
19. Lifter motor bracket assembly	20. Driver seat wiring harness	21. Seat cushion outer finisher	C
22. Leg cover	23. Bolt cover	24. Seat cushion frame	
25. Recliner switch knob	26. Slide switch knob	27. Power seat switch escutcheon	
28. Switch assembly	29. Seat cushion pad	30. Seat cushion heating element	D
31. Seat cushion trim	32. Lumbar support assembly	33. Seatback frame	
34. Seatback board	35. Headrest holder with multi position lock	36. Headrest holder	E
37. Lumbar support lever knob	38. Snap ring		

F

G

H

I

SE

K

L

M

N

O

P

FRONT SEAT

< ON-VEHICLE REPAIR >

Manual Driver Seat

SEC. 870

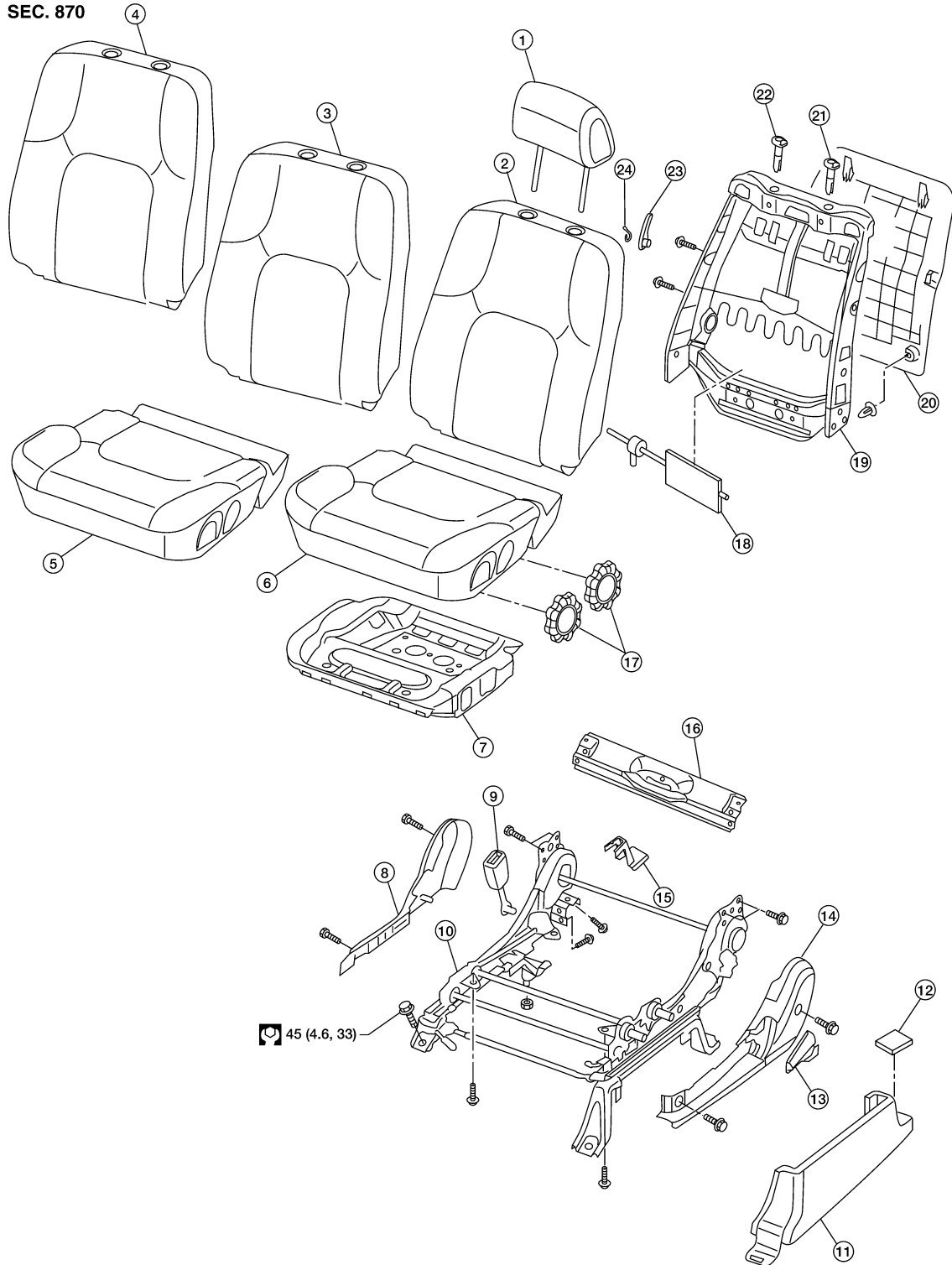

LIA2407E

- | | | |
|--|--------------------------------------|---------------------------------------|
| 1. Headrest | 2. Seatback pad without side air bag | 3. Seatback trim without side air bag |
| 4. Seatback assembly with side air bag | 5. Seat cushion trim cover | 6. Seat cushion pad |
| 7. Seat cushion frame | 8. Seat cushion inner finisher | 9. Seat belt buckle assembly |
| 10. Seat frame assembly | 11. Leg cover | 12. Bolt cover |
| 13. Recline lever | 14. Seat cushion outer finisher | 15. Leg cover |
| 16. Seat cushion rear finisher | 17. Seat cushion lift knobs | 18. Lumbar support assembly |

FRONT SEAT

< ON-VEHICLE REPAIR >

- | | | |
|---|-------------------------------|--|
| 19. Seatback frame without side air bag | 20. Seatback board | 21. Headrest holder with multi position lock |
| 22. Headrest holder | 23. Lumbar support lever knob | 24. Snap ring |

Conventional Passenger Seat

SEC. 870

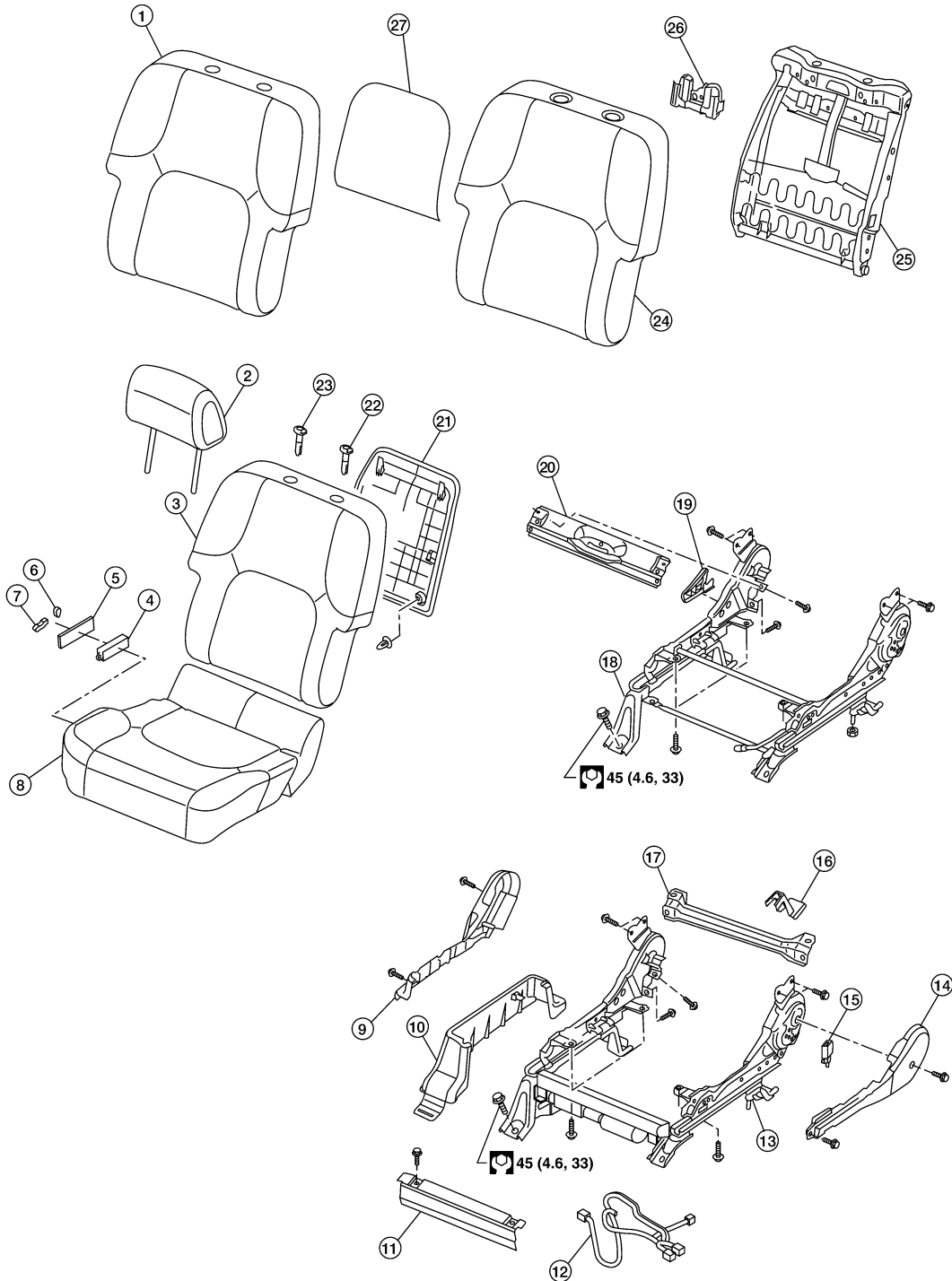

- | | | |
|---------------------------------------|---------------------------------|--|
| 1. Seatback trim without side air bag | 2. Headrest | 3. Seatback assembly with side air bag |
| 4. Switch assembly | 5. Power seat switch escutcheon | 6. Recliner switch knob |
| 7. Slide switch knob | 8. Seat cushion assembly | 9. Seat cushion outer cover |

LIA2408E

A
B
C
D
E
F
G
H
I
SE
K
L
M
N
O
P

FRONT SEAT

< ON-VEHICLE REPAIR >

- | | | |
|--|---------------------------------|---------------------------------------|
| 10. Leg cover | 11. Seat cushion front finisher | 12. Passenger seat wiring harness |
| 13. Power seat frame assembly | 14. Seat cushion inner finisher | 15. Seat belt buckle assembly |
| 16. Leg cover | 17. Seat cushion rear finisher | 18. Manual seat frame assembly |
| 19. Recline lever | 20. Seat cushion rear finisher | 21. Seatback board |
| 22. Headrest holder with multi position lock | 23. Headrest holder | 24. Seatback pad without side air bag |
| 25. Seatback frame without side air bag | 26. Damper assembly | 27. Seatback heating element |

Fold Flat Passenger Seat

SEC. 870

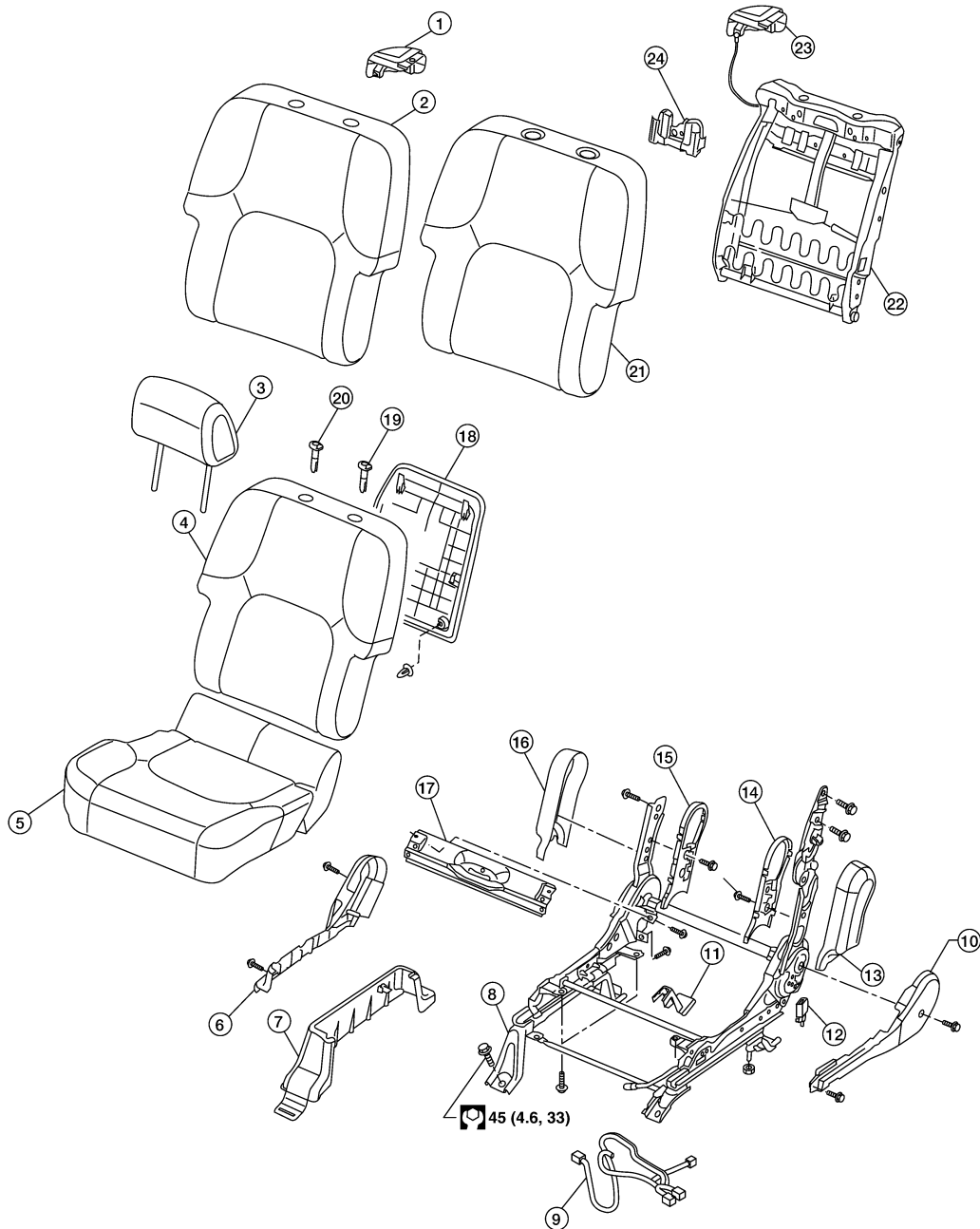

FRONT SEAT

< ON-VEHICLE REPAIR >

- | | | | |
|--|---|--|---|
| 1. Front seatback lever | 2. Seatback trim without side air bag | 3. Headrest | A |
| 4. Seatback assembly with side air bag | 5. Seat cushion assembly | 6. Seat cushion outer finisher | |
| 7. Leg cover | 8. Seat frame assembly | 9. Passenger seat wiring harness | |
| 10. Seat cushion inner cover | 11. Leg cover | 12. Seat belt buckle assembly | B |
| 13. Inboard reclining arm outer cover | 14. Inboard reclining arm inner cover | 15. Outboard reclining arm inner cover | |
| 16. Outboard reclining arm outer cover | 17. Seat cushion rear finisher | 18. Seatback board | |
| 19. Headrest holder with multi position lock | 20. Headrest holder | 21. Seatback pad without side air bag | C |
| 22. Seat back frame without side air bag | 23. Seatback fold flat release lever assembly | 24. Damper assembly | D |

Removal and Installation

INFOID:000000001303541

REMOVAL

When removing or installing the seat trim, handle it carefully to keep dirt out and avoid damage.

CAUTION:

- **Before removing the front seat, turn the ignition switch off, disconnect both battery cables and wait at least 3 minutes.**
- **When checking the power seat circuit for continuity using a circuit tester, do not confuse its connector with the side air bag module connector. Such an error may cause the air bag to deploy.**
- **Do not drop, tilt, or bump the side air bag module while installing the seat. Always handle it with care.**
- **After front side air bag module inflates, front seatback assembly must be replaced.**
- **Front passenger seat is equipped with an Occupant Classification System sensor and control module. Do not disassemble front passenger seat cushion assembly or remove the trim as this will affect the Occupant Classification System calibration.**
- **Always replace passenger seat cushion as an assembly.**

1. Slide the seat until the four body bolts are visible and a tool can be inserted.

NOTE:

Set the front/rear cushion lifters to the top position.

2. Disconnect both battery cables and wait at least 3 minutes.
3. Disconnect the side air bag module harness connector (if equipped).
4. Remove the four body bolts.
5. Disconnect the power seat harness connectors and remove the seat from the vehicle.

NOTE:

When removing and installing the seat, use shop cloths to protect the vehicle from damage.

INSTALLATION

Installation is in the reverse order of removal.

SE

K

L

M

N

O

P

REAR SEAT

< ON-VEHICLE REPAIR >

REAR SEAT

Removal and Installation

INFOID:000000001303544

Second Row Outboard

Removal

1. Tilt seat cushion forward.
2. Remove two seat bolts.

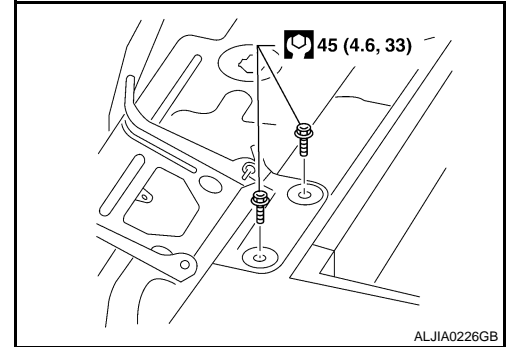

3. Lower seat cushion and tilt seatback forward.
4. Remove seat base trim cover.
5. Remove forward seat nuts and assembly.

Installation

Installation is in the reverse order of removal.

Second Row Center

Removal

1. Tilt the seat cushion forward.
2. Remove the seat cushion bolts and assembly.
3. Remove the seat back bolts and assembly.

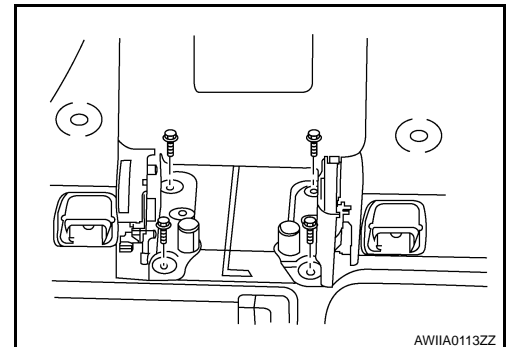

Installation

Installation is in the reverse order of removal.

Third Row

Removal

1. Remove the lower base trim covers.
2. Remove front anchor bolts.
3. Lower the seatback into the cargo floor position.
4. Remove the rear anchor bolts from the seat assembly.
5. Remove the seat assembly.

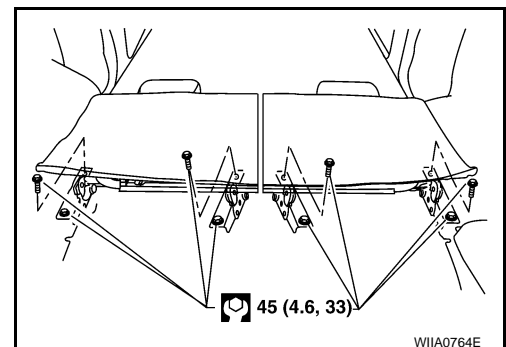

REAR SEAT

< ON-VEHICLE REPAIR >

Installation

Installation is in the reverse order of removal.

A

B

C

D

E

F

G

H

I

SE

K

L

M

N

O

P

FRONT SEAT

< DISASSEMBLY AND ASSEMBLY >

DISASSEMBLY AND ASSEMBLY

FRONT SEAT

Exploded View

INFOID:000000001308880

Power Driver Seat

SEC. 870

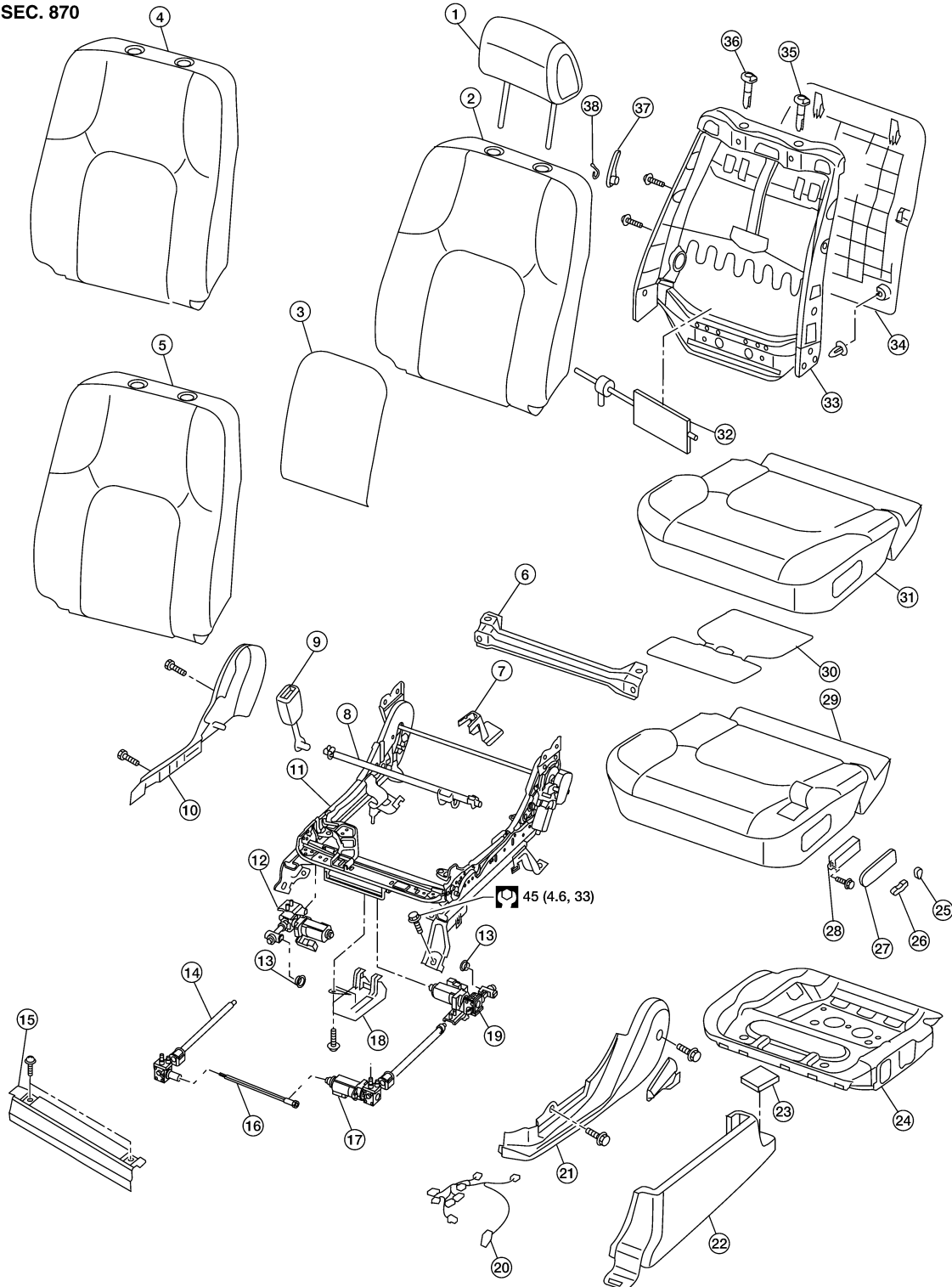

LIA2406E

FRONT SEAT

< DISASSEMBLY AND ASSEMBLY >

1. Headrest	2. Seatback pad without side air bag	3. Seatback heating element	A
4. Seatback assembly with side air bag	5. Seatback trim without side air bag	6. Power seat cushion rear finisher	
7. Leg Cover	8. Lifter motor link bar	9. Seat belt buckle assembly	
10. Seat cushion inner finisher	11. Seat frame assembly	12. Seat lifter motor assembly	B
13. Seat spacer	14. Lock gear	15. Seat cushion front finisher	
16. Flexible seat wire	17. Front seat slide motor assembly (LH)	18. Power seat control assembly	
19. Lifter motor bracket assembly	20. Driver seat wiring harness	21. Seat cushion outer finisher	C
22. Leg cover	23. Bolt cover	24. Seat cushion frame	
25. Recliner switch knob	26. Slide switch knob	27. Power seat switch escutcheon	
28. Switch assembly	29. Seat cushion pad	30. Seat cushion heating element	D
31. Seat cushion trim	32. Lumbar support assembly	33. Seatback frame	
34. Seatback board	35. Headrest holder with multi position lock	36. Headrest holder	E
37. Lumbar support lever knob	38. Snap ring		

F

G

H

I

SE

K

L

M

N

O

P

FRONT SEAT

< DISASSEMBLY AND ASSEMBLY >

Manual Driver Seat

SEC. 870

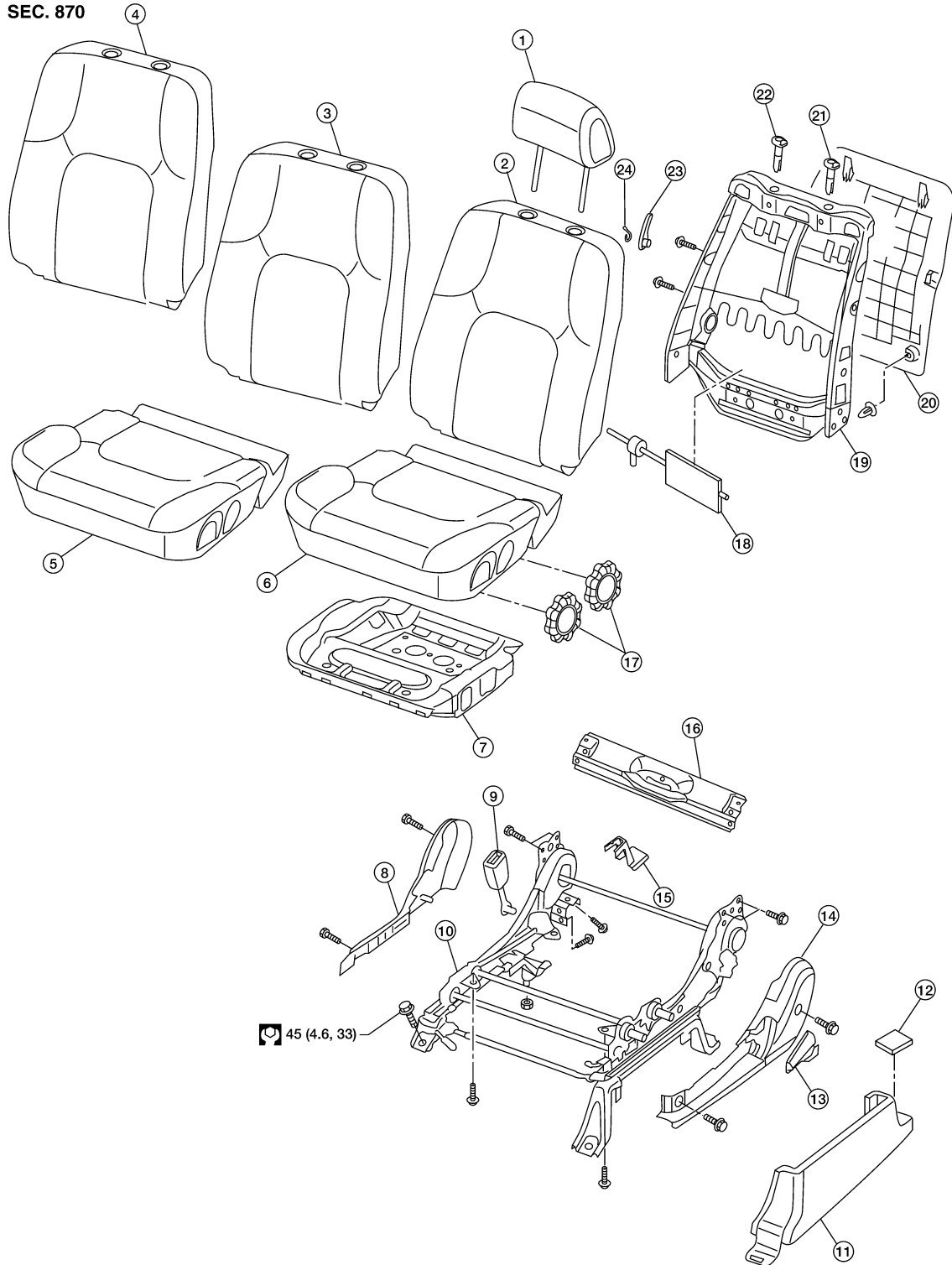

LIA2407E

- | | | |
|--|--------------------------------------|---------------------------------------|
| 1. Headrest | 2. Seatback pad without side air bag | 3. Seatback trim without side air bag |
| 4. Seatback assembly with side air bag | 5. Seat cushion trim cover | 6. Seat cushion pad |
| 7. Seat cushion frame | 8. Seat cushion inner finisher | 9. Seat belt buckle assembly |
| 10. Seat frame assembly | 11. Leg cover | 12. Bolt cover |
| 13. Recline lever | 14. Seat cushion outer finisher | 15. Leg cover |
| 16. Seat cushion rear finisher | 17. Seat cushion lift knobs | 18. Lumbar support assembly |

FRONT SEAT

< DISASSEMBLY AND ASSEMBLY >

- | | | |
|---|-------------------------------|--|
| 19. Seatback frame without side air bag | 20. Seatback board | 21. Headrest holder with multi position lock |
| 22. Headrest holder | 23. Lumbar support lever knob | 24. Snap ring |

Conventional Passenger Seat

SEC. 870

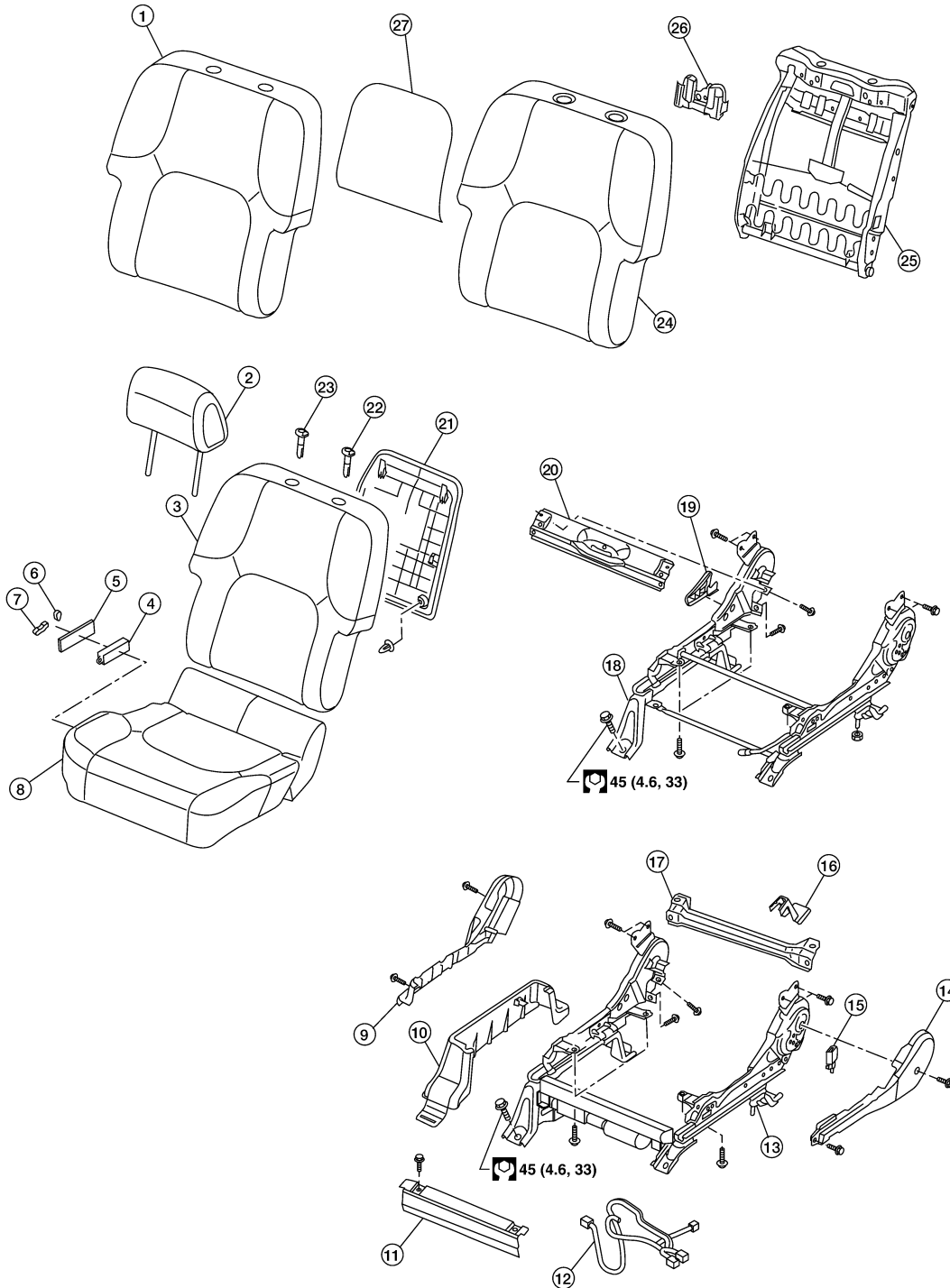

- | | | |
|---------------------------------------|---------------------------------|--|
| 1. Seatback trim without side air bag | 2. Headrest | 3. Seatback assembly with side air bag |
| 4. Switch assembly | 5. Power seat switch escutcheon | 6. Recliner switch knob |
| 7. Slide switch knob | 8. Seat cushion assembly | 9. Seat cushion outer cover |

LIA2408E

A
B
C
D
E
F
G
H
I
SE
K
L
M
N
O
P

FRONT SEAT

< DISASSEMBLY AND ASSEMBLY >

- | | | |
|--|---------------------------------|---------------------------------------|
| 10. Leg cover | 11. Seat cushion front finisher | 12. Passenger seat wiring harness |
| 13. Power seat frame assembly | 14. Seat cushion inner finisher | 15. Seat belt buckle assembly |
| 16. Leg cover | 17. Seat cushion rear finisher | 18. Manual seat frame assembly |
| 19. Recline lever | 20. Seat cushion rear finisher | 21. Seatback board |
| 22. Headrest holder with multi position lock | 23. Headrest holder | 24. Seatback pad without side air bag |
| 25. Seatback frame without side air bag | 26. Damper assembly | 27. Seatback heating element |

Fold Flat Passenger Seat

SEC. 870

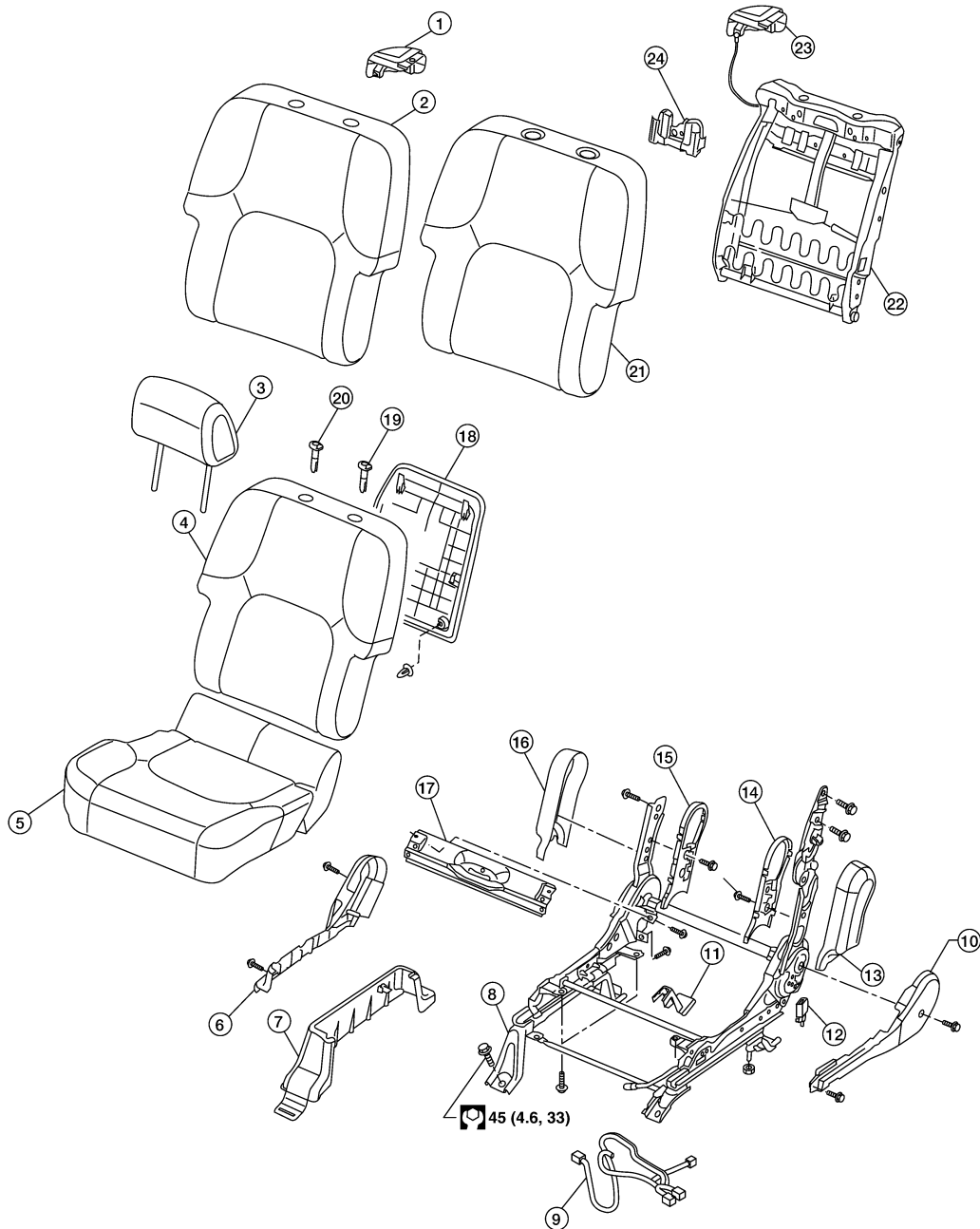

FRONT SEAT

< DISASSEMBLY AND ASSEMBLY >

- | | | | |
|--|---|--|---|
| 1. Front seatback lever | 2. Seatback trim without side air bag | 3. Headrest | A |
| 4. Seatback assembly with side air bag | 5. Seat cushion assembly | 6. Seat cushion outer finisher | B |
| 7. Leg cover | 8. Seat frame assembly | 9. Passenger seat wiring harness | B |
| 10. Seat cushion inner cover | 11. Leg cover | 12. Seat belt buckle assembly | C |
| 13. Inboard reclining arm outer cover | 14. Inboard reclining arm inner cover | 15. Outboard reclining arm inner cover | D |
| 16. Outboard reclining arm outer cover | 17. Seat cushion rear finisher | 18. Seatback board | E |
| 19. Headrest holder with multi position lock | 20. Headrest holder | 21. Seatback pad without side air bag | F |
| 22. Seat back frame without side air bag | 23. Seatback fold flat release lever assembly | 24. Damper assembly | G |

Seatback Assembly

INFOID:000000001308882

REMOVAL

NOTE:

On vehicles equipped with side air bags, only complete seatback assemblies can be replaced.

1. Remove the front seat assembly. Refer to [SE-29, "Removal and Installation"](#).
2. Remove the seatback board from the back of the seatback.

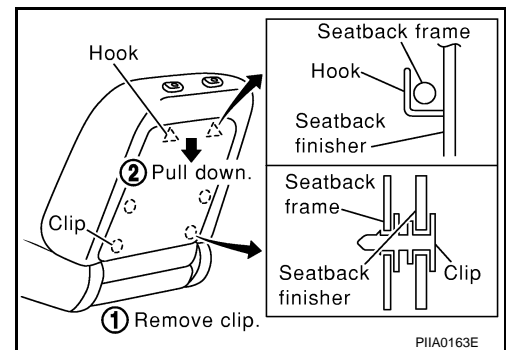

3. Remove the retainer.

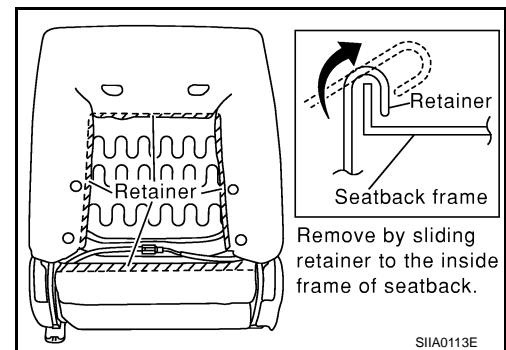

4. Disconnect the seatback heater harness.
5. Remove the seatback bolts (2 for each side) and seatback assembly.

DISASSEMBLY

NOTE:

On vehicles equipped with side air bags, only complete seatback assemblies can be replaced.

1. Remove the seatback assembly. Refer to "REMOVAL".
2. Remove the headrest.

FRONT SEAT

< DISASSEMBLY AND ASSEMBLY >

3. From inside of the seatback, squeeze the headrest holder tabs at the base of the stay pipe and pull up to remove.

NOTE:

Before installing the headrest holder, check its orientation (front/rear and right/left).

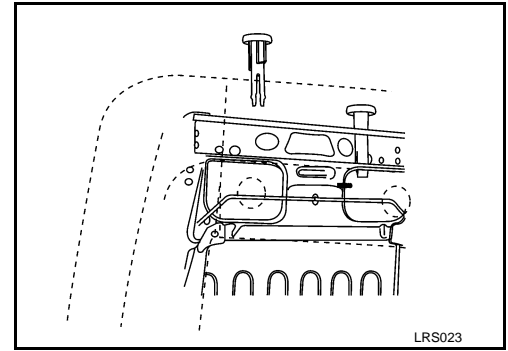

4. Remove the snap ring and the lumbar support lever knob.

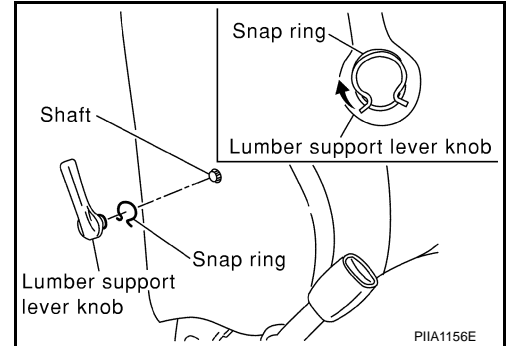

5. Remove the seatback trim and pad assembly.

6. Remove the hog ring to separate the seatback trim from the pad and the heating element (if equipped).

ASSEMBLY

Assembly is in the reverse order of disassembly.

INSTALLATION

Installation is in the reverse order of removal.

Seat Cushion Trim and Pad

INFOID:000000001308883

REMOVAL

CAUTION:

- Front passenger seat is equipped with an Occupant Classification System sensor and control module. Do not disassemble front passenger seat cushion assembly or remove the trim as this will affect the Occupant Classification System calibration.
- Always replace passenger seat cushion as an assembly.
- When removed, the passenger seat cushion must always be placed pan side UP to prevent damage.
- During installation, the wire harness clips must be reinstalled in the holes they were originally in. Do not add additional clips.
- The Occupant Classification System control module can only be replaced as part of the seat cushion assembly.

1. Remove the front seat assembly. Refer to [SE-29, "Removal and Installation"](#).

2. Remove the power seat switch knobs and power seat switch escutcheon (if equipped)(or lift knobs on manual seats)..

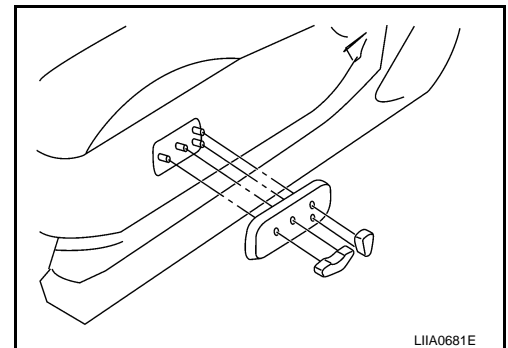

FRONT SEAT

< DISASSEMBLY AND ASSEMBLY >

3. Remove the seat cushion outer finisher.

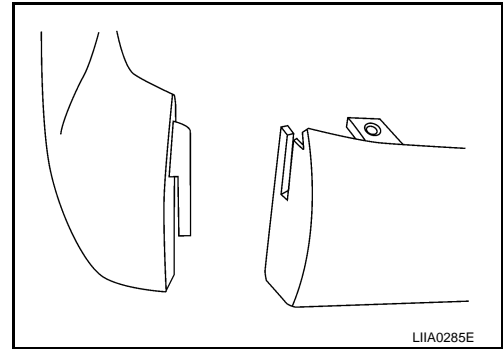

4. Remove the power seat switch screws .
5. Remove four bolts and the seat cushion assembly.
 - On the fold flat passenger seat it is necessary to unclip the rear flap j-clip from the seat pan.

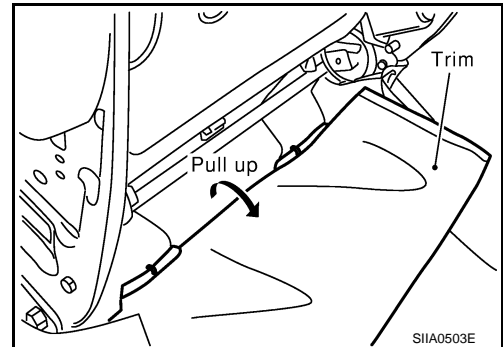

6. Remove the retainer on the seat cushion frame, then remove the harness connector for the seat cushion heater (if equipped).

DISASSEMBLY

CAUTION:

- **Front passenger seat is equipped with an Occupant Classification System sensor and control module. Do not disassemble front passenger seat cushion assembly or remove the trim as this will affect the Occupant Classification System calibration.**

1. Remove the seat cushion assembly. Refer to .
2. On the drivers seat only, remove the hog rings to separate the trim cover from the pad and seat cushion heater unit.

ASSEMBLY

Assembly is in the reverse order of disassembly.

INSTALLATION

Installation is in the reverse order of removal.

A
B
C
D
E
F
G
H
I
SE
K
L
M
N
O
P

REAR SEAT

< DISASSEMBLY AND ASSEMBLY >

REAR SEAT

Exploded View

INFOID:000000001308893

Disassembly and Assembly

INFOID:000000001308879

Second Row Outer

SEC. 880

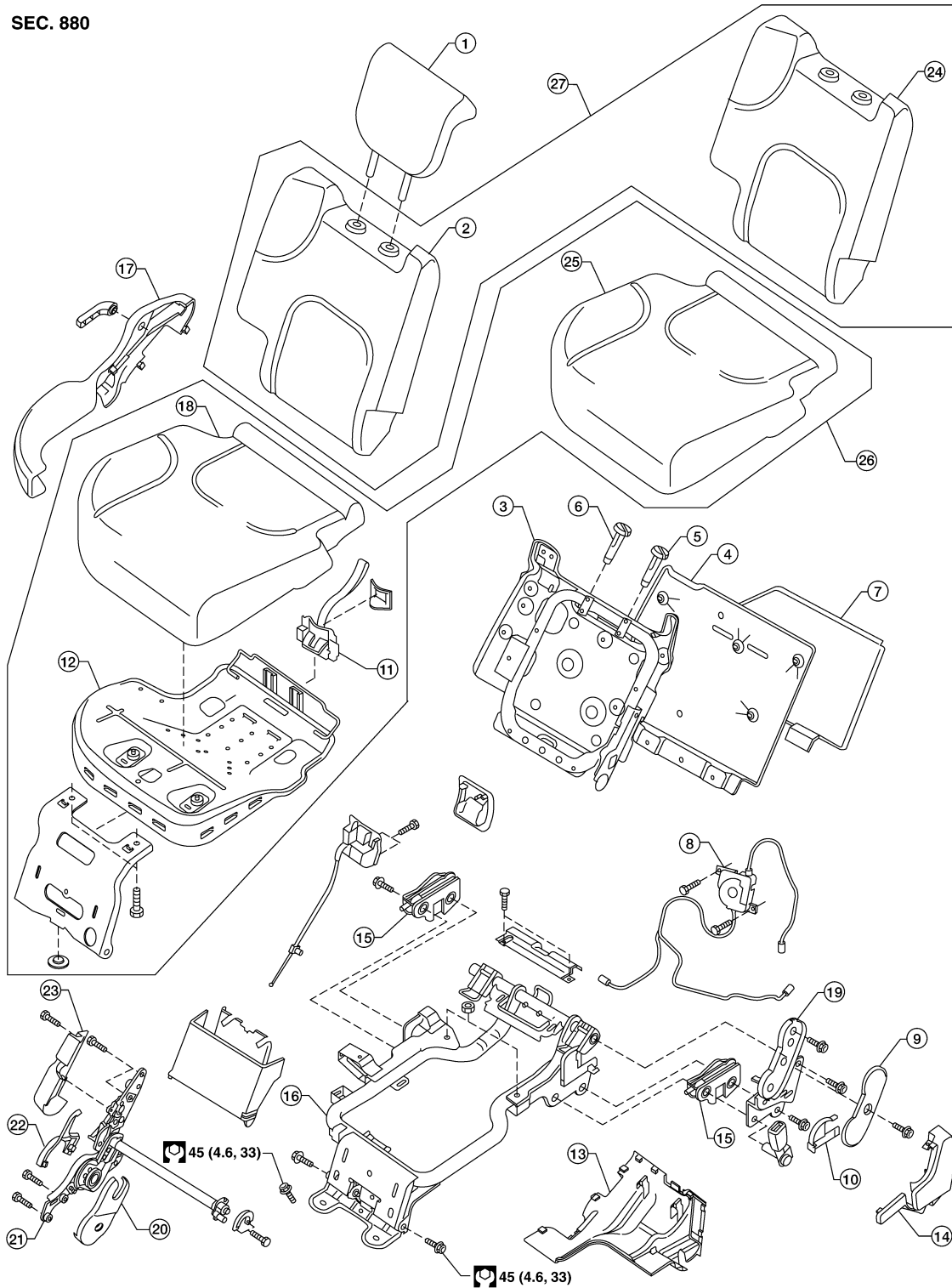

ALJIA0227GB

REAR SEAT

< DISASSEMBLY AND ASSEMBLY >

1. Headrest	2. Seatback pad	3. Seatback frame	A
4. Seatback panel	5. LH Headrest guide	6. RH Headrest guide	
7. Flipper panel	8. Seat actuator assembly	9. Reclining device inner cover	
10. Reclining device inner mid cover	11. Latch assembly	12. Seat cushion frame assembly	B
13. Lower rear seat cover	14. Lower rear seat cover inner	15. Cushion floor latch	
16. Seat cushion support frame assembly	17. Lower rear seat cover outer	18. Seat cushion pad	C
19. Inner inboard reclining device cover	20. Inner outboard reclining device cover	21. Reclining device lever	
22. Reclining device outer mid cover	23. Reclining device outer cover	24. Seatback trim cover	
25. Seat cushion trim cover	26. Seat cushion assembly	27. Seatback assembly	D

E

F

G

H

I

SE

K

L

M

N

O

P

REAR SEAT

< DISASSEMBLY AND ASSEMBLY >

Second row center

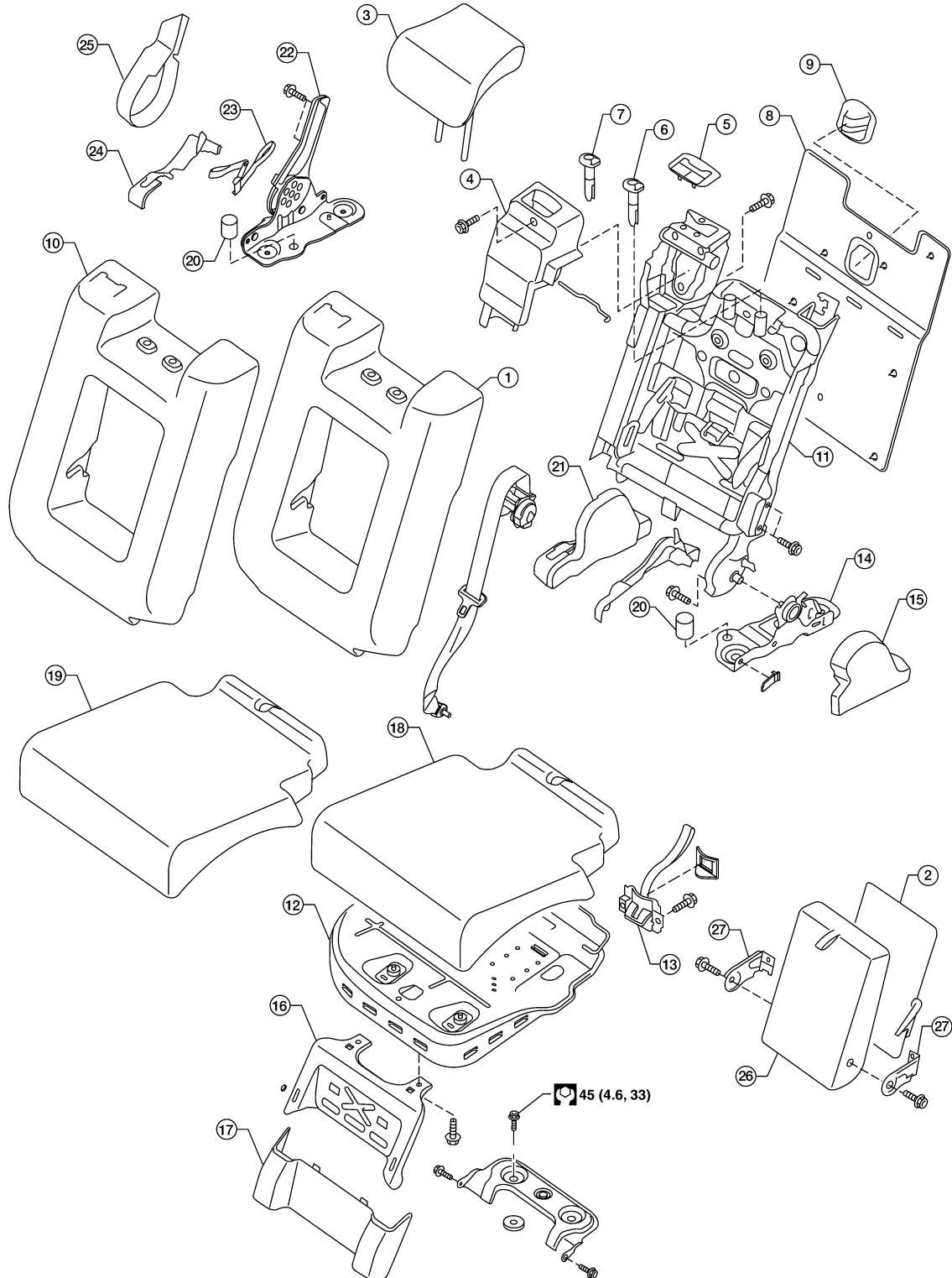

BIIA0021E

- | | | |
|-------------------------------|--------------------------------------|------------------------------|
| 1. Seatback pad | 2. Armrest finisher | 3. Headrest |
| 4. Seat belt retractor cover | 5. Seat belt bezel | 6. LH headrest guide locking |
| 7. RH headrest guide free | 8. Seatback board | 9. Seat bracket cover |
| 10. Seatback trim cover | 11. Seatback frame | 12. Seat cushion frame |
| 13. Latch assembly | 14. Lower rear pivot bracket support | 15. Outer hinge cover |
| 16. Center seat base assembly | 17. Link and pivot bracket apron | 18. Seat cushion pad |
| 19. Seat cushion trim cover | 20. Cushion stop bumper | 21. Inner lever cover |

REAR SEAT

< DISASSEMBLY AND ASSEMBLY >

- | | | |
|-----------------------------|-------------------------|-----------------------|
| 22. Seatback hinge assembly | 23. Seat lever assembly | 24. Outer lever cover |
| 25. Seat lock cover | 26. Armrest | 27. Armrest bracket |
| 28. Seat cushion assembly | 29. Seatback assembly | |

Third row

SEC. 882

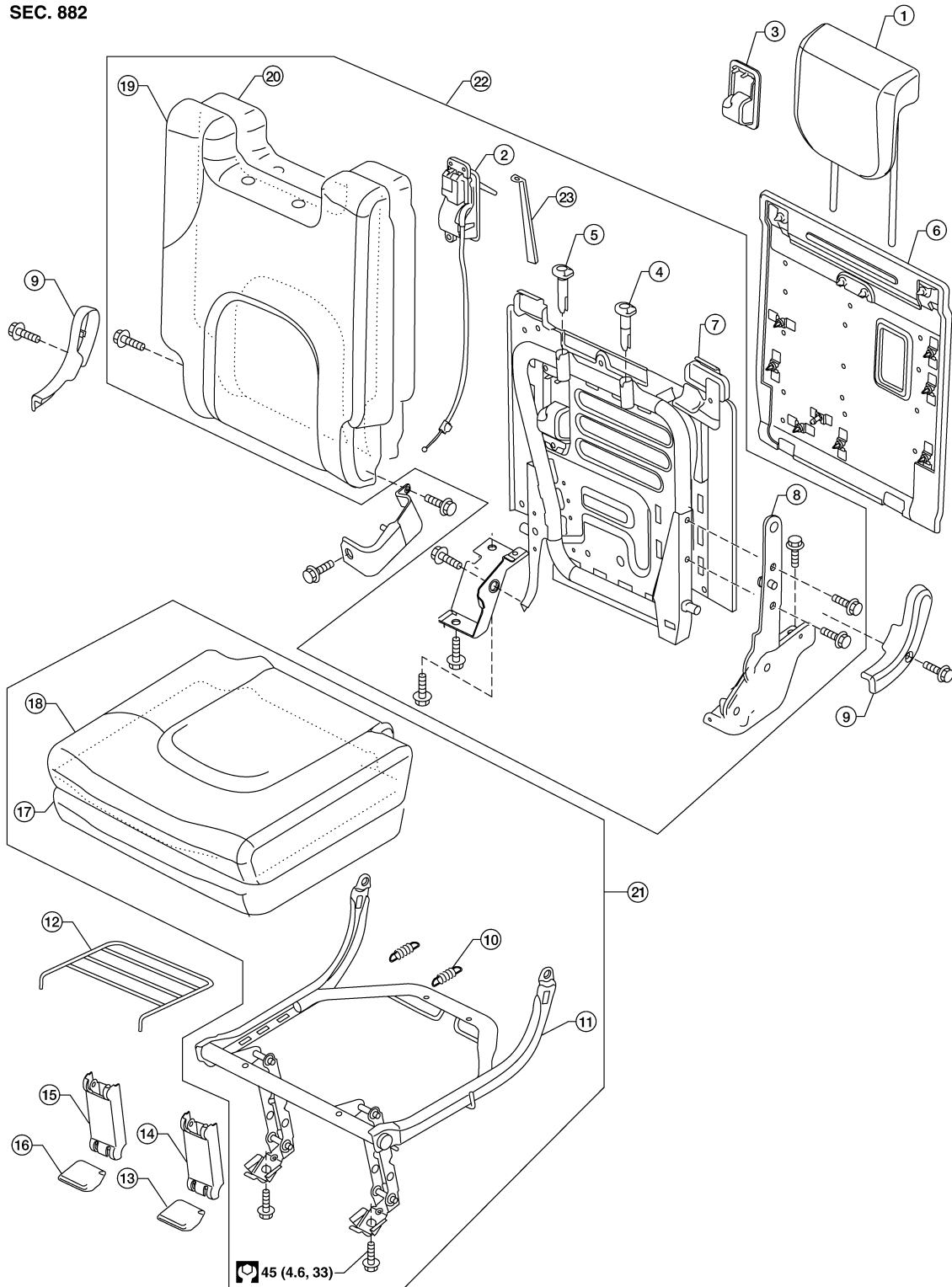

- | | | |
|---------------------------|-----------------------------|-------------------------|
| 1. Headrests | 2. Release handle and cable | 3. Release handle cover |
| 4. Headrest locking guide | 5. Headrest guide free | 6. Seatback panel |
| 7. Seatback frame | 8. Seatback latch | 9. Side link cover |

ALJIA0233GB

A
B
C
D
E
F
G
H
I
SE
K
L
M
N
O
P

REAR SEAT

< DISASSEMBLY AND ASSEMBLY >

- | | | |
|----------------------------|-------------------------|-----------------------------|
| 10. Extension spring | 11. Seat cushion frame | 12. Flex mat |
| 13. Floor bracket cover LH | 14. Front link cover LH | 15. Front link cover RH |
| 16. Floor bracket cover RH | 17. Seat cushion pad | 18. Seat cushion trim cover |
| 19. Seatback trim cover | 20. Seatback pad | 21. Seat cushion assembly |
| 22. Seatback assembly | 23. Strap | |