

Edition: May 2007

Revision: May 2007

Publication No. SM8E-1R51U0

NISSAN PATHFINDER MODEL R51 SERIES

All rights reserved. No part of this Service Manual may be reproduced or stored in a retrieval system, or transmitted in any form, or by any means, electronic, mechanical, photo-copying, recording or otherwise, without the prior written permission of Nissan North America, Inc.

QUICK REFERENCE INDEX

A GENERAL INFORMATION	GI General Information	
B ENGINE	EM Engine Mechanical	
	LU Engine Lubrication System	
	CO Engine Cooling System	
	EC Engine Control System	
	FL Fuel System	
	EX Exhaust System	
	STR Starting System	
	ACC Accelerator Control System	
	C HYBRID	HBC Hybrid Control System
		HBB Hybrid Battery System
HBR Hybrid Brake System		
D TRANSMISSION & DRIVE-LINE	TM Transaxle & Transmission	
	DLN Driveline	
	FAX Front Axle	
	RAX Rear Axle	
E SUSPENSION	FSU Front Suspension	
	RSU Rear Suspension	
	SCS Suspension Control System	
	WT Road Wheels & Tires	
F BRAKES	BR Brake System	
	PB Parking Brake System	
	BRC Brake Control System	
	ST Steering System	
G STEERING	STC Steering Control System	
	SB Seat Belt	
H RESTRAINTS	SBC Seat Belt Control System	
	SR SRS Airbag	
	SRC SRS Airbag Control System	
	VTL Ventilation System	
I VENTILATION, HEATER & AIR CONDITIONER	HA Heater & Air Conditioning System	
	HAC Heater & Air Conditioning Control System	
	INT Interior	
J BODY INTERIOR	IP Instrument Panel	
	SE Seat	
	ADP Automatic Drive Postioner	
	AP Adjustable Pedal	
K BODY EXTERIOR, DOORS, ROOF & VEHICLE SECURITY	DLK Door & Lock	
	SEC Security Control System	
	GW Glass & Window System	
	PWC Power Window Control System	
	RF Roof	
	EXT Exterior	
	BRM Body Repair Manual	
	MIR Mirrors	
L DRIVER CONTROLS	EXL Exterior Lighting System	
	INL Interior Lighting System	
	WW Wiper & Washer	
	DEF Defogger	
	HRN Horn	
	PWO Power Outlet	
	BCS Body Control System	
	LAN LAN System	
M ELECTRICAL & POWER CONTROL	PCS Power Control System	
	CHG Charging System	
	PG Power Supply, Ground & Circuit Elements	
	MWI Meter, Warning Lamp & Indicator	
	WCS Warning Chime System	
N DRIVER INFORMATION & MULTIMEDIA	SN Sonar System	
	AV Audio, Visual & Navigation System	
	CCS Cruise Control System	
O CRUISE CONTROL	MA Maintenance	
P MAINTENANCE		

A

B

C

D

E

F

G

H

I

J

K

L

M

N

O

P

FOREWORD

This manual contains maintenance and repair procedure for the 2008 NISSAN PATHFINDER.

In order to assure your safety and the efficient functioning of the vehicle, this manual should be read thoroughly. It is especially important that the PRECAUTIONS in the GI section be completely understood before starting any repair task.

All information in this manual is based on the latest product information at the time of publication. The right is reserved to make changes in specifications and methods at any time without notice.

IMPORTANT SAFETY NOTICE

The proper performance of service is essential for both the safety of the technician and the efficient functioning of the vehicle.

The service methods in this Service Manual are described in such a manner that the service may be performed safely and accurately. Service varies with the procedures used, the skills of the technician and the tools and parts available. Accordingly, anyone using service procedures, tools or parts which are not specifically recommended by NISSAN must first be completely satisfied that neither personal safety nor the vehicle's safety will be jeopardized by the service method selected.



NISSAN NORTH AMERICA, INC.
Technical Publications Department



PLEASE HELP MAKE THIS SERVICE MANUAL BETTER!

Your comments are important to NISSAN and will help us to improve our Service Manuals.
Use this form to report any issues or comments you may have regarding our Service Manuals.

Please print this form and type or write your comments below. Mail or fax to:

Nissan North America, Inc.
Technical Service Information
39001 Sunrise Drive, P.O. Box 9200
Farmington Hills, MI USA 48331
FAX: (248) 488-3910

SERVICE MANUAL: Model: _____ **Year:** _____

PUBLICATION NO. (Refer to Quick Reference Index): _____

Please describe any Service Manual issues or problems in detail:

Page number(s) _____ *Note: Please include a copy of each page, marked with your comments.*

Are the trouble diagnosis procedures logical and easy to use? (circle your answer) YES NO

If no, what page number(s)? _____ *Note: Please include a copy of each page, marked with your comments.*

Please describe the issue or problem in detail: _____

Is the organization of the manual clear and easy to follow? (circle your answer) YES NO

Please comment: _____

What information should be included in NISSAN Service Manuals to better support you in servicing or repairing customer vehicles?

DATE: _____ YOUR NAME: _____ POSITION: _____

DEALER: _____ DEALER NO.: _____ ADDRESS: _____

CITY: _____ STATE/PROV./COUNTRY: _____ ZIP/POSTAL CODE: _____

QUICK REFERENCE CHART: PATHFINDER

Engine Tune-up Data: VQ40DE

INFOID:000000001733188

GENERAL SPECIFICATIONS

Cylinder arrangement		V-6
Displacement cm ³ (cu in)		3,954 (241.30)
Bore and stroke mm (in)		95.5 × 92.0 (3.76 × 3.622)
Valve arrangement		DOHC
Firing order		1-2-3-4-5-6
Number of piston rings	Compression	2
	Oil	1
Number of main bearings		4
Compression ratio		9.7
Compression pressure (kg/cm ² , psi)/300 rpm	kPa	
	Standard	1,275 (13.0, 185)
	Minimum	981 (10.0, 142)
Differential limit between cylinders		98 (1.0, 14)

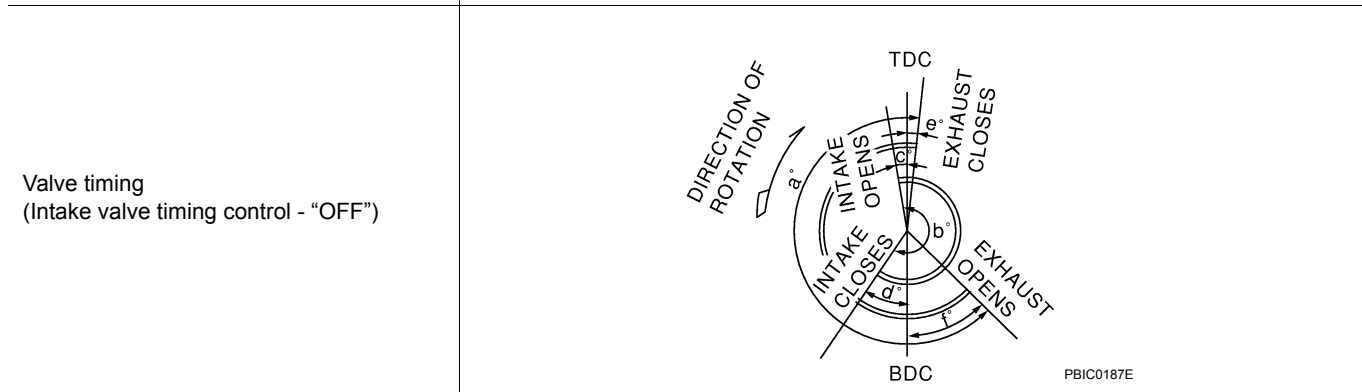
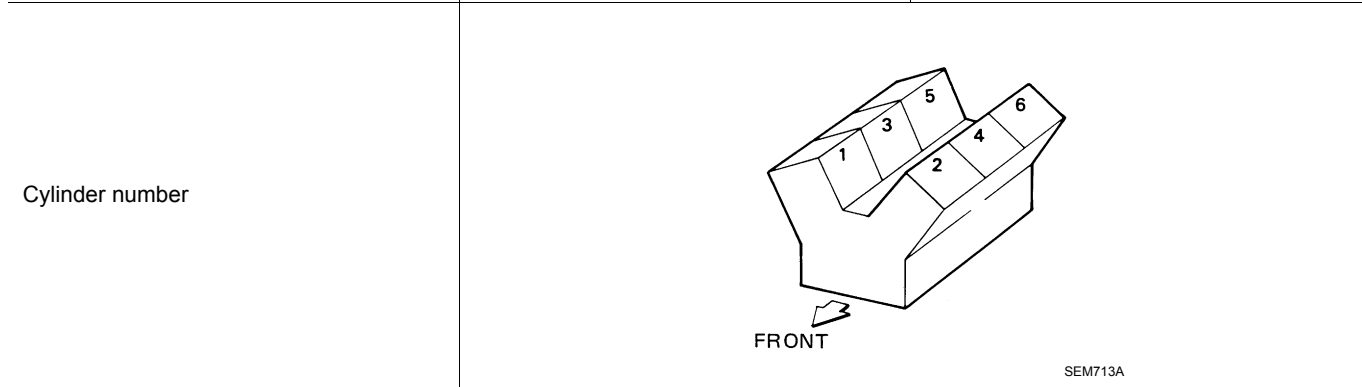

Unit: degree

a	b	c	d	e	f
244	240	-4	64	6	58

QUICK REFERENCE CHART: PATHFINDER

2008

Engine Tune-up Data : VK56DE

INFOID:000000001733189

GENERAL SPECIFICATIONS

Cylinder arrangement		V-8
Displacement cm ³ (in ³)		5,552 (338.80)
Bore and stroke mm (in)		98 x 92 (3.86 x 3.62)
Valve arrangement		DOHC
Firing order		1-8-7-3-6-5-4-2
Number of piston rings	Compression	2
	Oil	1
Number of main bearings		5
Compression ratio		9.8:1
Compression pressure (kg/cm ² , psi)/rpm	kPa	
	Standard	1,520 (15.5, 220)/200
	Minimum	1,324 (13.5, 192)/200
Differential limit between cylinders		98 (1.0, 14)/200

Cylinder number

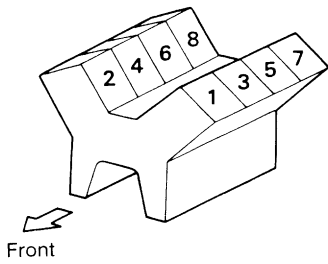

SEM957C

Valve timing

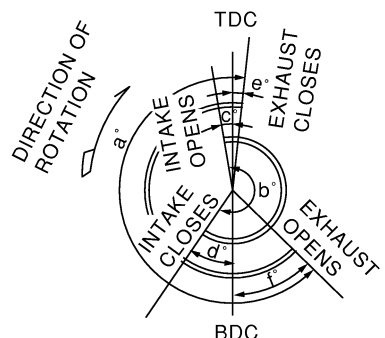

PBIC0187E

Unit: degree

a	b	c	d	e	f
244°	232°	8°	60°	10°	54°

QUICK REFERENCE CHART: PATHFINDER

2008

Front Wheel Alignment (Unladen*1)

INFOID:000000001733190

Drive type		2WD	4WD
Camber Degree minute (decimal degree)	Minimum	-0° 30' (-0.50°)	-0° 15' (-0.25°)
	Nominal	0° 15' (0.25°)	0° 30' (0.50°)
	Maximum	1° 00' (1.00°)	1° 15' (1.25°)
	Cross camber	0° 45' (0.75°) or less	0° 45' (0.75°) or less
Caster Degree minute (decimal degree)	Minimum	2° 15' (2.25°)	2° 00' (2.00°)
	Nominal	3° 0' (3.00°)	2° 45' (2.75°)
	Maximum	3° 45' (3.75°)	3° 30' (3.50°)
	Cross caster	0° 45' (0.75°) or less	0° 45' (0.75°) or less
Kingpin inclination Degree minute (decimal degree)	Nominal	13° 0' (13.00°)	12° 45' (12.75°)

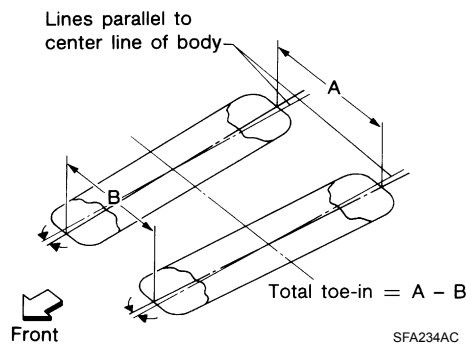

Total toe-in	Distance (A - B)	Minimum	2.1 mm (0.08 in)	2.1 mm (0.08 in)
		Nominal	3.1 mm (0.12 in)	3.1 mm (0.12 in)
		Maximum	4.1 mm (0.16 in)	4.1 mm (0.16 in)
	Angle (left wheel or right wheel) Degree minute (decimal degree)	Minimum	0° 5' (0.08°)	0° 5' (0.08°)
		Nominal	0° 7' (0.12°)	0° 7' (0.12°)
		Maximum	0° 9' (0.15°)	0° 9' (0.15°)
Wheel turning angle (full turn)	Inside Degree minute (Decimal degree)	33° 26' - 35° 26' *2 (33.43° - 35.43°)	33° 33' - 35° 33' *4 (33.60° - 35.60°)	
	Outside Degree minute (Decimal degree)	29° 22' - 31° 22' *3 (29.37° - 31.37°)	29° 38' - 31° 38' *5 (29.73° - 31.73°)	

*1: Fuel, radiator coolant and engine oil full. Spare tire, jack, hand tools and mats in designated positions.

*2: Target value 35° 26' (35.43°)

*3: Target value 31° 22' (31.37°)

*4: Target value 35° 33' (35.55°)

*5: Target value 31° 38' (31.63°)

Rear Wheel Alignment

INFOID:000000001733191

Camber Degree minute (decimal degree)	Minimum	- 0° 32' (- 0.53°)
	Nominal	- 0° 2' (- 0.03°)
	Maximum	0° 28' (0.47°)

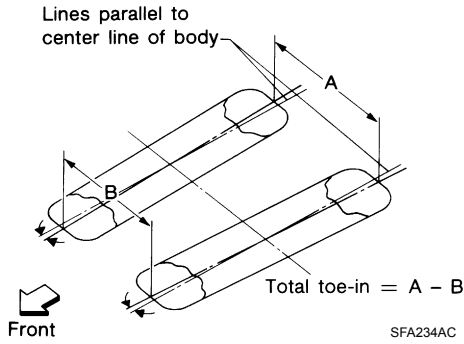

Total toe-in	Distance (A - B)	Minimum	- 1.4 mm (- 0.055 in)
		Nominal	1.9 mm (0.075 in)
		Maximum	5.2 mm (0.205 in)
		Cross toe	0 ± 2 mm (0 ± 0.079 in)
	Angle (left, right) Degree minute (decimal degree)	Minimum	- 0° 3' (-0.05°)
		Nominal	0° 4' (0.07°)
Maximum		0° 11' (0.18°)	

Wheelarch Height (Unladen*)

INFOID:000000001733192

Unit: mm (in)

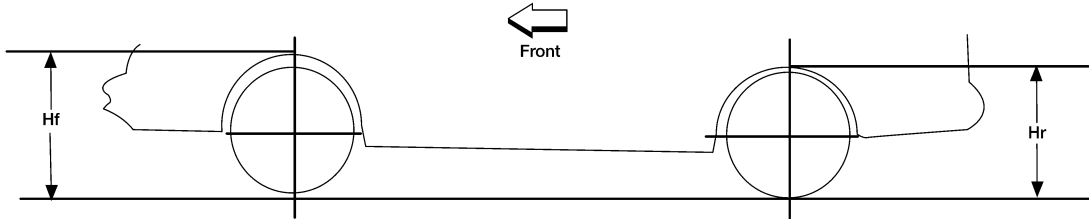

LEIA0085E

Engine	VQ40DE							VK56DE	
Drive type	2WD			Part time 4WD			Full time 4WD	2WD	4WD
Tire size	245/ 75R16	265/ 70R16	265/ 65R17	245/ 75R16	265/ 70R16	265/ 75R16	265/ 65R17	265/60R18	
Front wheelarch height (Hf)	867 (34.13)	865 (34.06)	865 (34.06)	875 (34.45)	873 (34.37)	889 (35.00)	874 (34.41)	868 (34.17)	876 (34.49)
Rear wheelarch height (Hr)	875 (34.45)	873 (34.37)	873 (34.37)	884 (34.80)	882 (34.72)	898 (35.35)	883 (34.76)	876 (34.49)	886 (34.88)

*1: Fuel, radiator coolant and engine oil full. Spare tire, jack, hand tools and mats in designated positions.

Brake General Specification

INFOID:000000001733193

Unit: mm (in)

Front brake	Brake model	CLZ33VB
	Rotor outer diameter × thickness	296 × 28 (11.654 × 1.102)
	Pad Length × width × thickness	111.0 × 73.5 × 10.0 (4.73 × 2.894 × 0.394)
	Cylinder bore diameter (each)	46.4 (1.83)

QUICK REFERENCE CHART: PATHFINDER

2008

Rear brake	Brake model	CLZ14VB
	Rotor outer diameter × thickness	308 × 18 (12.126 × 0.709)
	Pad Length × width × thickness	83.0 × 33.0 × 11.0 (3.268 × 1.299 × 0.433)
	Cylinder bore diameter	38.1 (1.50)
Control valve	Valve model	Electric brake force distribution
Brake booster	Booster model	C215T
	Diaphragm diameter	215 (8.46)
Recommended brake fluid		Refer to Fluids and Lubricants

Brake Pedal

INFOID:000000001733194

Unit: mm (in)

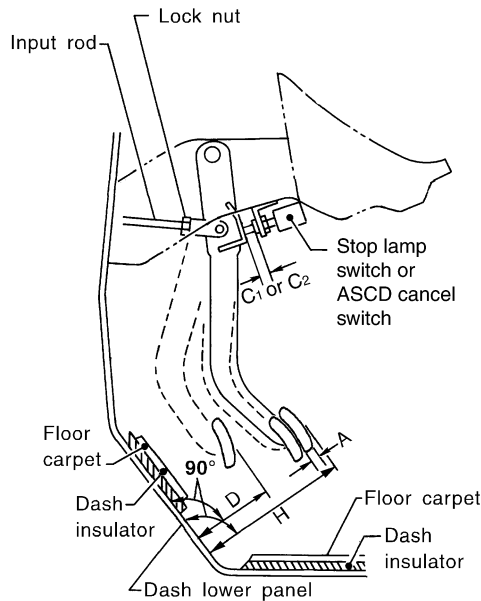

WFIA0160E

Free height "H"	182.1 - 192.1 (7.17 - 7.56)
Depressed pedal height ("D" [under a force of 490 N (50 kg, 110 lb) with engine running])	105 - 115 (4.13 - 4.53)
Clearance between pedal stopper and threaded end of stop lamp switch and ASCD switch "C1" or "C2"	0.74 - 1.96 (0.029 - 0.077)
Pedal play "A"	3 - 11 (0.12 - 0.43)

Front Disc Brake

INFOID:000000001733195

Unit: mm (in)

Brake model		CLZ33VB
Brake pad	Standard thickness (new)	10.0 (0.394)
	Repair limit thickness	2.0 (0.079)
Disc rotor	Standard thickness (new)	28.0 (1.102)
	Repair limit thickness	26.0 (1.024)
	Maximum uneven wear (measured at 8 positions)	0.015 (0.0006)
	Runout limit (with it attached to the vehicle)	0.05 (0.0020)

QUICK REFERENCE CHART: PATHFINDER

2008

Rear Disc Brake

INFOID:000000001733196

Unit: mm (in)

Brake model		CLZ14VB
Brake pad	Standard thickness (new)	11.0 (0.433)
	Repair limit thickness	2.0 (0.079)
Disc rotor	Standard thickness (new)	18.0 (0.709)
	Repair limit thickness	16.0 (0.630)
	Maximum uneven wear (measured at 8 positions)	0.015 (0.0006)
	Runout limit (with it attached to the vehicle)	0.05 (0.0020)

Fluids and Lubricants

INFOID:000000001733197

Description			Capacity (Approximate)		
			Metric	US measure	Imp measure
Fuel			80 ℓ	21 1/8 gal	17 5/8 gal
Engine oil Drain and refill	With oil filter change	VQ40DE	5.1 ℓ	5 3/8 qt	4 1/2 qt
		VK56DE	6.2 ℓ	6 1/2 qt	5 1/2 qt
	Without oil filter change	VQ40DE	4.8 ℓ	5 1/8 qt	4 1/4 qt
		VK56DE	5.9 ℓ	6 1/4 qt	5 1/4 qt
Dry engine (engine overhaul)		VQ40DE	6.3 ℓ	6 5/8 qt	5 1/2 qt
		VK56DE	7.6 ℓ	8 qt	6 3/4 qt
Cooling system (with reservoir at "MAX" level)		Without rear A/C	10.2 ℓ	2 3/4 gal	2 1/4 gal
		With rear A/C	13.4 ℓ	3 1/2 gal	3 gal
Automatic transmission fluid (ATF)			10.3 ℓ	10 7/8 qt	9 1/8 qt
Rear final drive oil		VQ40DE	1.4 ℓ	3 pt	2 1/2 pt
		VK56DE	1.75 ℓ	3 3/4 pt	3 1/8 pt
Transfer fluid		ATX14B	3.0 ℓ	3 1/8 qt	2 5/8 qt
		TX15B	2.0 ℓ	2 1/8 qt	1 3/4 qt
Front final drive oil		VQ40DE	0.85 ℓ	1 3/4 pt	1 1/2 pt
		VK56DE	1.6 ℓ	3 3/8 pt	2 7/8 pt
Power steering fluid (PSF)			1.0 ℓ	2 1/8 pt	1 3/4 pt
Brake fluid			—	—	—
Multi-purpose grease			—	—	—
Windshield washer fluid			4.5 ℓ	1 1/4 gal	1 gal
A/C system refrigerant		Without rear A/C	0.70 ± 0.05 kg	1.54 ± 0.11 lb	1.54 ± 0.11 lb
		With rear A/C	0.85 ± 0.05 kg	1.87 ± 0.11 lb	1.87 ± 0.11 lb
A/C system oil		Without rear A/C	180 m ℓ	6.1 fl oz	6.3 fl oz
		With rear A/C	210 m ℓ	7.1 fl oz	7.4 fl oz