

SECTION **RF**
ROOF

A
B
C
D
E
F
G
H
RF
J
K
L
M

CONTENTS

PRECAUTIONS	2	CAN Communication System Description	12
Precautions for Supplemental Restraint System (SRS) "AIR BAG" and "SEAT BELT PRE-TENSIONER"	2	Wiring Diagram — SROOF —	13
Precautions	2	Terminals and Reference Values for BCM	15
PREPARATION	3	Sunroof Motor Assembly Harness Connector Terminal Layout	15
Special service tool	3	Terminals and Reference Values for Sunroof Motor Assembly	15
Commercial Service Tool	3	Work Flow	15
SQUEAK AND RATTLE TROUBLE DIAGNOSES	4	CONSULT-II Function (BCM)	16
Work Flow	4	CONSULT-II START OPERATION	16
CUSTOMER INTERVIEW	4	Work Support	16
DUPLICATE THE NOISE AND TEST DRIVE	5	Active Test	16
CHECK RELATED SERVICE BULLETINS	5	Data Monitor	16
LOCATE THE NOISE AND IDENTIFY THE ROOT CAUSE	5	Trouble Diagnosis Chart by Symptom	17
REPAIR THE CAUSE	5	BCM Power Supply and Ground Circuit Check	17
CONFIRM THE REPAIR	6	Sunroof Switch System Check	17
Generic Squeak and Rattle Troubleshooting	6	Sunroof Motor Assembly Power Supply and Ground Circuit Check	19
INSTRUMENT PANEL	6	Door Switch Check	20
CENTER CONSOLE	6	Adjustment	22
DOORS	6	GAP ADJUSTMENT	22
TRUNK	7	HEIGHT DIFFERENCE ADJUSTMENT	22
SUNROOF/HEADLINING	7	Removal and Installation	23
OVERHEAD CONSOLE (FRONT AND REAR).....	7	SUNROOF UNIT	24
SEATS	7	GLASS LID	24
UNDERHOOD	7	WIND DEFLECTOR	25
Diagnostic Worksheet	8	SUNSHADE	25
SUNROOF	10	SUNROOF MOTOR	25
Component Parts and Harness Connector Location ..	10	DRAIN HOSES	26
System Description	10	WEATHERSTRIP	27
OUTLINE	10	LINK AND WIRE ASSEMBLY	27
OPERATION	10		

PRECAUTIONS

PRECAUTIONS

PF0:00001

Precautions for Supplemental Restraint System (SRS) “AIR BAG” and “SEAT BELT PRE-TENSIONER”

EIS007SU

The Supplemental Restraint System such as “AIR BAG” and “SEAT BELT PRE-TENSIONER”, used along with a front seat belt, helps to reduce the risk or severity of injury to the driver and front passenger for certain types of collision. This system includes seat belt switch inputs and dual stage front air bag modules. The SRS system uses the seat belt switches to determine the front air bag deployment, and may only deploy one front air bag, depending on the severity of a collision and whether the front occupants are belted or unbelted. Information necessary to service the system safely is included in the SRS and SB section of this Service Manual.

WARNING:

- **To avoid rendering the SRS inoperative, which could increase the risk of personal injury or death in the event of a collision which would result in air bag inflation, all maintenance must be performed by an authorized NISSAN/INFINITI dealer.**
- **Improper maintenance, including incorrect removal and installation of the SRS, can lead to personal injury caused by unintentional activation of the system. For removal of Spiral Cable and Air Bag Module, see the SRS section.**
- **Do not use electrical test equipment on any circuit related to the SRS unless instructed to in this Service Manual. SRS wiring harnesses can be identified by yellow and/or orange harnesses or harness connectors.**

Precautions

EIS007SV

- Disconnect both battery cables in advance.
- Never tamper with or force air bag lid open, as this may adversely affect air bag performance.
- Be careful not to scratch pad and other parts.
- When removing or disassembling any part, be careful not to damage or deform it. Protect parts which may get in the way with cloth.
- When removing parts with a screwdriver or other tool, protect parts by wrapping them with vinyl or tape.
- Keep removed parts protected with cloth.
- If a clip is deformed or damaged, replace it.
- If an un reusable part is removed, replace it with a new one.
- Tighten bolts and nuts firmly to the specified torque.
- After re-assembly has been completed, make sure each part functions correctly.
- Remove stains in the following way.

Water-soluble stains:

Dip a soft cloth in warm water, and then squeeze it tightly. After wiping the stain, wipe with a soft dry cloth.

Oil stain:

Dissolve a synthetic detergent in warm water (density of 2 to 3% or less), dip the cloth, then clean off the stain with the cloth. Next, dip the cloth in fresh water and squeeze it tightly. Then clean off the detergent completely. Then wipe the area with a soft dry cloth.

- Do not use any organic solvent, such as thinner or benzine.

PREPARATION

PREPARATION

PF0:00002

Special service tool

EIS007SW

The actual shapes of Kent-Moore tools may differ from those of special service tools illustrated here.

Tool number (Kent-Moore No.) Tool name	Description
— (J-39570) Chassis ear	Locating the noise
— (J-43980) NISSAN Squeak and Rattle Kit	Repairing the cause of noise

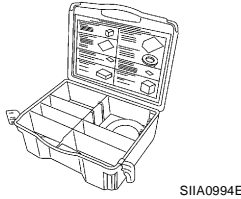
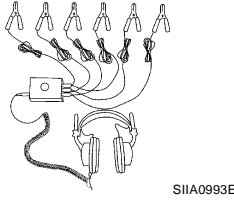

Commercial Service Tool

EIS007SX

(Kent-Moore No.) Tool name	Description
(J-39565) Engine ear	Locating the noise

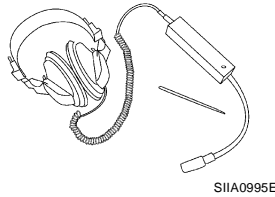

SQUEAK AND RATTLE TROUBLE DIAGNOSES

SQUEAK AND RATTLE TROUBLE DIAGNOSES

PF0:0000

Work Flow

EIS007SY

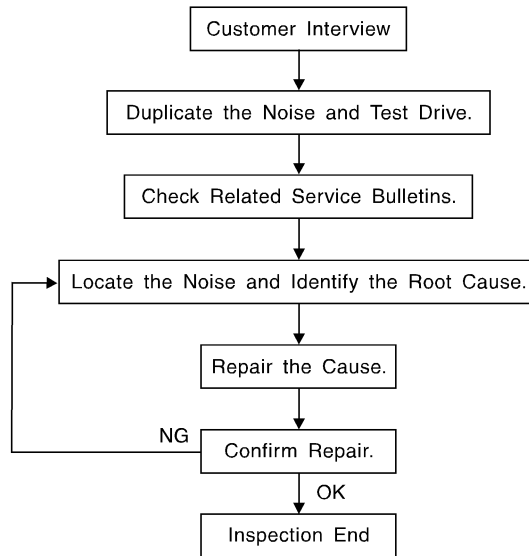

SBT842

CUSTOMER INTERVIEW

Interview the customer if possible, to determine the conditions that exist when the noise occurs. Use the Diagnostic Worksheet during the interview to document the facts and conditions when the noise occurs and any customer's comments; refer to [RF-8, "Diagnostic Worksheet"](#). This information is necessary to duplicate the conditions that exist when the noise occurs.

- The customer may not be able to provide a detailed description or the location of the noise. Attempt to obtain all the facts and conditions that exist when the noise occurs (or does not occur).
- If there is more than one noise in the vehicle, be sure to diagnose and repair the noise that the customer is concerned about. This can be accomplished by test driving the vehicle with the customer.
- After identifying the type of noise, isolate the noise in terms of its characteristics. The noise characteristics are provided so the customer, service adviser and technician are all speaking the same language when defining the noise.
- Squeak —(Like tennis shoes on a clean floor)
Squeak characteristics include the light contact/fast movement/brought on by road conditions/hard surfaces = higher pitch noise/softer surfaces = lower pitch noises/edge to surface = chirping.
- Creak—(Like walking on an old wooden floor)
Creak characteristics include firm contact/slow movement/twisting with a rotational movement/pitch dependent on materials/often brought on by activity.
- Rattle—(Like shaking a baby rattle)
Rattle characteristics include the fast repeated contact/vibration or similar movement/loose parts/missing clip or fastener/incorrect clearance.
- Knock —(Like a knock on a door)
Knock characteristics include hollow sounding/sometimes repeating/often brought on by driver action.
- Tick—(Like a clock second hand)
Tick characteristics include gentle contacting of light materials/loose components/can be caused by driver action or road conditions.
- Thump—(Heavy, muffled knock noise)
Thump characteristics include softer knock/dead sound often brought on by activity.
- Buzz—(Like a bumble bee)
Buzz characteristics include high frequency rattle/firm contact.
- Often the degree of acceptable noise level will vary depending upon the person. A noise that you may judge as acceptable may be very irritating to the customer.
- Weather conditions, especially humidity and temperature, may have a great effect on noise level.

SQUEAK AND RATTLE TROUBLE DIAGNOSES

DUPLICATE THE NOISE AND TEST DRIVE

If possible, drive the vehicle with the customer until the noise is duplicated. Note any additional information on the Diagnostic Worksheet regarding the conditions or location of the noise. This information can be used to duplicate the same conditions when you confirm the repair.

If the noise can be duplicated easily during the test drive, to help identify the source of the noise, try to duplicate the noise with the vehicle stopped by doing one or all of the following:

- 1) Close a door.
 - 2) Tap or push/pull around the area where the noise appears to be coming from.
 - 3) Rev the engine.
 - 4) Use a floor jack to recreate vehicle "twist".
 - 5) At idle, apply engine load (electrical load, half-clutch on M/T model, drive position on A/T model).
 - 6) Raise the vehicle on a hoist and hit a tire with a rubber hammer.
- Drive the vehicle and attempt to duplicate the conditions the customer states exist when the noise occurs.
 - If it is difficult to duplicate the noise, drive the vehicle slowly on an undulating or rough road to stress the vehicle body.

CHECK RELATED SERVICE BULLETINS

After verifying the customer concern or symptom, check ASIST for Technical Service Bulletins (TSBs) related to that concern or symptom.

If a TSB relates to the symptom, follow the procedure to repair the noise.

LOCATE THE NOISE AND IDENTIFY THE ROOT CAUSE

1. Narrow down the noise to a general area. To help pinpoint the source of the noise, use a listening tool (Chassis Ear: J-39570, Engine Ear: J-39565 and mechanic's stethoscope).
2. Narrow down the noise to a more specific area and identify the cause of the noise by:
 - removing the components in the area that you suspect the noise is coming from. Do not use too much force when removing clips and fasteners, otherwise clips and fasteners can be broken or lost during the repair, resulting in the creation of new noise.
 - tapping or pushing/pulling the component that you suspect is causing the noise. Do not tap or push/pull the component with excessive force, otherwise the noise will be eliminated only temporarily.
 - feeling for a vibration with your hand by touching the component(s) that you suspect is (are) causing the noise.
 - placing a piece of paper between components that you suspect are causing the noise.
 - looking for loose components and contact marks.
Refer to [RF-6, "Generic Squeak and Rattle Troubleshooting"](#).

REPAIR THE CAUSE

- If the cause is a loose component, tighten the component securely.
- If the cause is insufficient clearance between components:
 - separate components by repositioning or loosening and retightening the component, if possible.
 - insulate components with a suitable insulator such as urethane pads, foam blocks, felt cloth tape or urethane tape. A NISSAN Squeak and Rattle Kit (J-43980) is available through your authorized NISSAN Parts Department.

CAUTION:

Do not use excessive force as many components are constructed of plastic and may be damaged.

Always check with the Parts Department for the latest parts information.

The following materials are contained in the NISSAN Squeak and Rattle Kit (J-43980). Each item can be ordered separately as needed.

URETHANE PADS [1.5 mm (0.059 in) thick]

Insulates connectors, harness, etc.

76268-9E005: 100×135 mm (3.94×5.31 in)/76884-71L01: 60×85 mm (2.36×3.35 in)/76884-71L02: 15×25 mm (0.59×0.98 in)

INSULATOR (Foam blocks)

Insulates components from contact. Can be used to fill space behind a panel.

73982-9E000: 45 mm (1.77 in) thick, 50×50 mm (1.97×1.97 in)/73982-50Y00: 10 mm (0.39 in) thick, 50×50 mm (1.97×1.97 in)

INSULATOR (Light foam block)

SQUEAK AND RATTLE TROUBLE DIAGNOSES

80845-71L00: 30 mm (1.18 in) thick, 30×50 mm (1.18×1.97 in)

FELT CLOTH TAPE

Used to insulate where movement does not occur. Ideal for instrument panel applications.

68370-4B000: 15×25 mm (0.59×0.98 in) pad/68239-13E00: 5 mm (0.20 in) wide tape roll. The following materials not found in the kit can also be used to repair squeaks and rattles.

UHMW (TEFLON) TAPE

Insulates where slight movement is present. Ideal for instrument panel applications.

SILICONE GREASE

Used instead of UHMW tape that will be visible or not fit.

Note: Will only last a few months.

SILICONE SPRAY

Use when grease cannot be applied.

DUCT TAPE

Use to eliminate movement.

CONFIRM THE REPAIR

Confirm that the cause of a noise is repaired by test driving the vehicle. Operate the vehicle under the same conditions as when the noise originally occurred. Refer to the notes on the Diagnostic Worksheet.

Generic Squeak and Rattle Troubleshooting

EIS007SZ

Refer to Table of Contents for specific component removal and installation information.

INSTRUMENT PANEL

Most incidents are caused by contact and movement between:

1. The cluster lid A and instrument panel
2. Acrylic lens and combination meter housing
3. Instrument panel to front pillar garnish
4. Instrument panel to windshield
5. Instrument panel mounting pins
6. Wiring harnesses behind the combination meter
7. A/C defroster duct and duct joint

These incidents can usually be located by tapping or moving the components to duplicate the noise or by pressing on the components while driving to stop the noise. Most of these incidents can be repaired by applying felt cloth tape or silicone spray (in hard to reach areas). Urethane pads can be used to insulate wiring harness.

CAUTION:

Do not use silicone spray to isolate a squeak or rattle. If you saturate the area with silicone, you will not be able to recheck the repair.

CENTER CONSOLE

Components to pay attention to include:

1. Shifter assembly cover to finisher
2. A/C control unit and cluster lid C
3. Wiring harnesses behind audio and A/C control unit

The instrument panel repair and isolation procedures also apply to the center console.

DOORS

Pay attention to the:

1. Finisher and inner panel making a slapping noise
2. Inside handle escutcheon to door finisher
3. Wiring harnesses tapping
4. Door striker out of alignment causing a popping noise on starts and stops

Tapping or moving the components or pressing on them while driving to duplicate the conditions can isolate many of these incidents. You can usually insulate the areas with felt cloth tape or insulator foam blocks from the NISSAN Squeak and Rattle Kit (J-43980) to repair the noise.

SQUEAK AND RATTLE TROUBLE DIAGNOSES

TRUNK

Trunk noises are often caused by a loose jack or loose items put into the trunk by the owner. In addition look for:

1. Trunk lid bumpers out of adjustment
2. Trunk lid striker out of adjustment
3. The trunk lid torsion bars knocking together
4. A loose license plate or bracket

Most of these incidents can be repaired by adjusting, securing or insulating the item(s) or component(s) causing the noise.

SUNROOF/HEADLINING

Noises in the sunroof/headlining area can often be traced to one of the following:

1. Sunroof lid, rail, linkage or seals making a rattle or light knocking noise
2. Sun visor shaft shaking in the holder
3. Front or rear windshield touching headliner and squeaking

Again, pressing on the components to stop the noise while duplicating the conditions can isolate most of these incidents. Repairs usually consist of insulating with felt cloth tape.

OVERHEAD CONSOLE (FRONT AND REAR)

Overhead console noises are often caused by the console panel clips not being engaged correctly. Most of these incidents are repaired by pushing up on the console at the clip locations until the clips engage.

In addition look for:

1. Loose harness or harness connectors.
2. Front console map/reading lamp lens loose.
3. Loose screws at console attachment points.

SEATS

When isolating seat noise it's important to note the position the seat is in and the load placed on the seat when the noise is present. These conditions should be duplicated when verifying and isolating the cause of the noise.

Cause of seat noise include:

1. Headrest rods and holder
2. A squeak between the seat pad cushion and frame
3. The rear seatback lock and bracket

These noises can be isolated by moving or pressing on the suspected components while duplicating the conditions under which the noise occurs. Most of these incidents can be repaired by repositioning the component or applying urethane tape to the contact area.

UNDERHOOD

Some interior noise may be caused by components under the hood or on the engine wall. The noise is then transmitted into the passenger compartment.

Causes of transmitted underhood noise include:

1. Any component mounted to the engine wall
2. Components that pass through the engine wall
3. Engine wall mounts and connectors
4. Loose radiator mounting pins
5. Hood bumpers out of adjustment
6. Hood striker out of adjustment

These noises can be difficult to isolate since they cannot be reached from the interior of the vehicle. The best method is to secure, move or insulate one component at a time and test drive the vehicle. Also, engine RPM or load can be changed to isolate the noise. Repairs can usually be made by moving, adjusting, securing, or insulating the component causing the noise.

A

B

C

D

E

F

G

H

RF

J

K

L

M

SQUEAK AND RATTLE TROUBLE DIAGNOSES

EIS00770

Diagnostic Worksheet

Dear Customer:

We are concerned about your satisfaction with your vehicle. Repairing a squeak or rattle sometimes can be very difficult. To help us fix your vehicle right the first time, please take a moment to note the area of the vehicle where the squeak or rattle occurs and under what conditions. You may be asked to take a test drive with a service advisor or technician to ensure we confirm the noise you are hearing.

SQUEAK & RATTLE DIAGNOSTIC WORKSHEET

I. WHERE DOES THE NOISE COME FROM? (circle the area of the vehicle)

The illustrations are for reference only, and may not reflect the actual configuration of your vehicle.

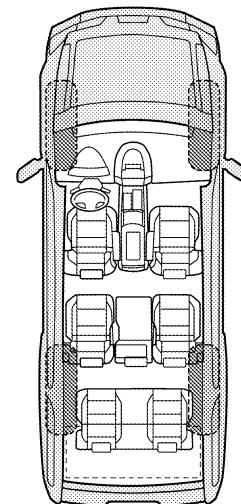
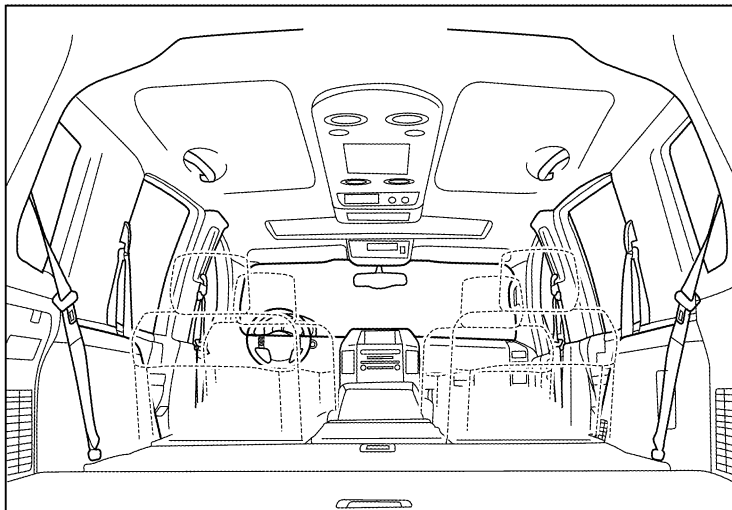
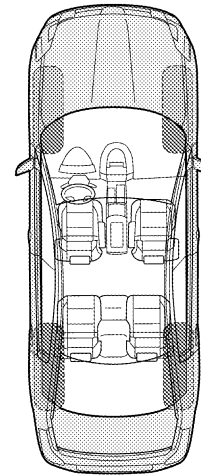
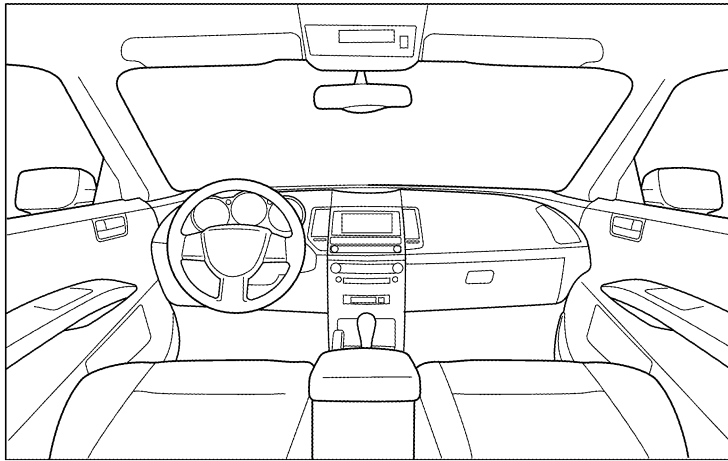

Continue to page 2 of the worksheet and briefly describe the location of the noise or rattle. In addition, please indicate the conditions which are present when the noise occurs.

SQUEAK AND RATTLE TROUBLE DIAGNOSES

SQUEAK & RATTLE DIAGNOSTIC WORKSHEET - page 2

Briefly describe the location where the noise occurs:

II. WHEN DOES IT OCCUR? (please check the boxes that apply)

- | | |
|---|--|
| <input type="checkbox"/> Anytime | <input type="checkbox"/> After sitting out in the rain |
| <input type="checkbox"/> 1st time in the morning | <input type="checkbox"/> When it is raining or wet |
| <input type="checkbox"/> Only when it is cold outside | <input type="checkbox"/> Dry or dusty conditions |
| <input type="checkbox"/> Only when it is hot outside | <input type="checkbox"/> Other: |

III. WHEN DRIVING:

- Through driveways
- Over rough roads
- Over speed bumps
- Only about ____ mph
- On acceleration
- Coming to a stop
- On turns: left, right or either (circle)
- With passengers or cargo
- Other: _____
- After driving ____ miles or ____ minutes

IV. WHAT TYPE OF NOISE

- Squeak (like tennis shoes on a clean floor)
- Creak (like walking on an old wooden floor)
- Rattle (like shaking a baby rattle)
- Knock (like a knock at the door)
- Tick (like a clock second hand)
- Thump (heavy muffled knock noise)
- Buzz (like a bumble bee)

TO BE COMPLETED BY DEALERSHIP PERSONNEL

Test Drive Notes:

	YES	NO	Initials of person performing
Vehicle test driven with customer	<input type="checkbox"/>	<input type="checkbox"/>	_____
- Noise verified on test drive	<input type="checkbox"/>	<input type="checkbox"/>	_____
- Noise source located and repaired	<input type="checkbox"/>	<input type="checkbox"/>	_____
- Follow up test drive performed to confirm repair	<input type="checkbox"/>	<input type="checkbox"/>	_____

VIN: _____ Customer Name _____

W.O.# _____ Date: _____

This form must be attached to Work Order

LAIA0071E

SUNROOF

Component Parts and Harness Connector Location

EIS007T1

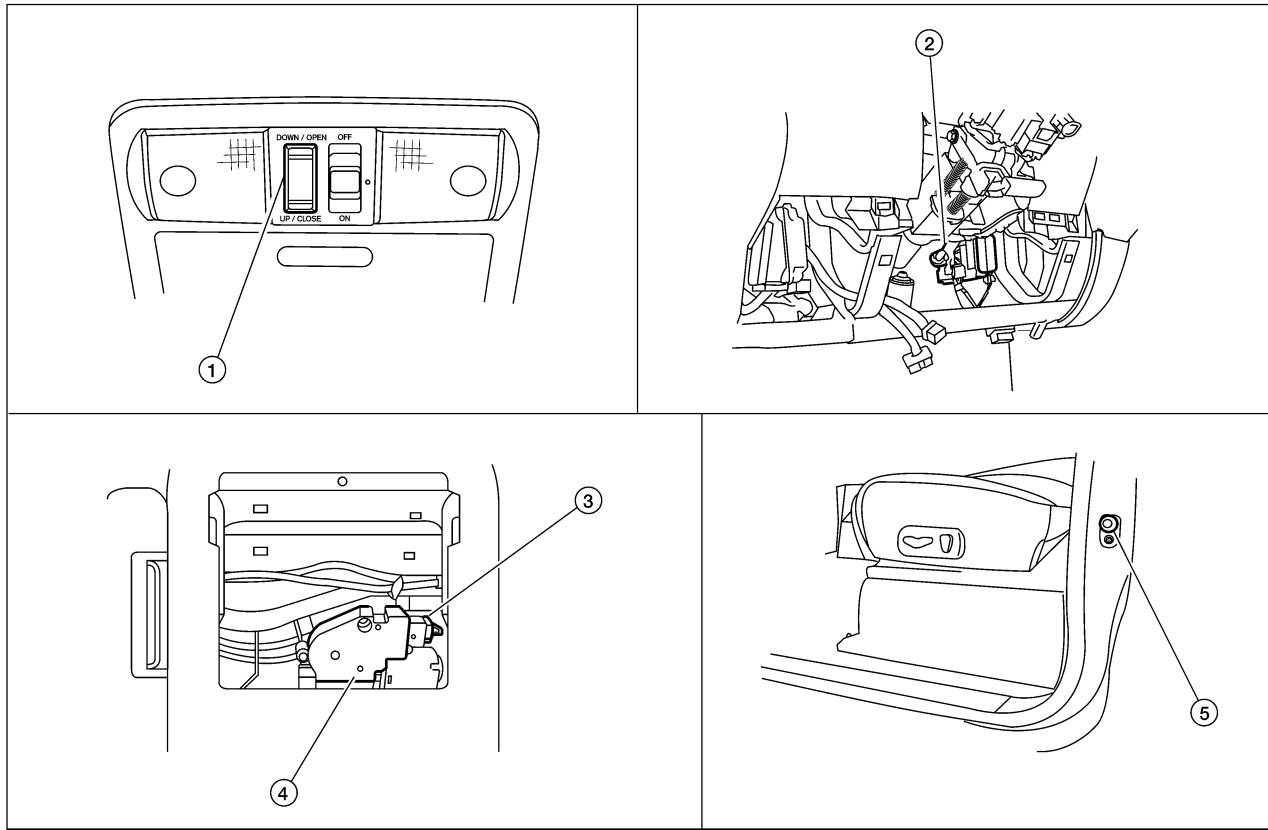

LIA2410E

- | | | |
|---------------------------|---|--|
| 1. Sunroof switch R4 | 2. BCM M18, M19, M20
(view with instrument lower panel LH removed) | 3. Sunroof motor harness connector B83 |
| 4. Sunroof motor assembly | 5. Front door switch
LH B8
RH B108 | |

System Description OUTLINE

EIS007T2

Electric sunroof system consists of

- Sunroof switch
- Sunroof motor assembly
- BCM (body control module)

BCM supplies power to the sunroof motor. Sunroof operation depends on sunroof switch condition.

OPERATION

Power is supplied at all times

- through 50A fusible link (letter **g** , located in the fuse and fusible link box)
- to BCM terminal 70, and
- through BCM terminal 69
- to sunroof motor assembly terminal 7.

When the ignition switch is in the ON or START position, power is supplied

- through 10A fuse [No.1, located in the fuse block (J/B)]
- to BCM terminal 38, and
- through BCM terminal 68
- to sunroof motor assembly terminal 9.

SUNROOF

Ground is supplied

- to BCM terminal 67
- through grounds M57, M61 and M79.

TILT UP/SLIDE CLOSE OPERATION

When up/close switch is pressed, ground is supplied

- to sunroof motor assembly terminal 1
- through sunroof switch terminal 3
- through sunroof switch terminal 2
- through grounds M57, M61 and M79.

Then the sunroof will tilt up/slide closed.

TILT DOWN/SLIDE OPEN OPERATION

When down/open switch is pressed, ground is supplied

- to sunroof motor assembly terminal 5
- through sunroof switch terminal 1
- through sunroof switch terminal 2
- through grounds M57, M61 and M79.

Then the sunroof will tilt down/slide open.

AUTO OPERATION

The power sunroof AUTO feature makes it possible to slide open and slide closed or tilt up and tilt down the sunroof without holding the sunroof switch in the UP/CLOSE or DOWN/OPEN position.

RETAINED POWER OPERATION

When the ignition switch is turned to OFF position from ON position, power is supplied for 45 seconds

- through BCM terminal 68
- to sunroof motor assembly terminal 9.

When power is supplied, the sunroof can be operated.

The retained power operation is canceled when the front door LH or RH is opened.

RAP signal period can be changed by CONSULT-II. Refer to [RF-16, "CONSULT-II Function \(BCM\)"](#).

ANTI-PINCH FUNCTION

The CPU (central processing unit) of sunroof motor assembly monitors the sunroof motor operation and the sunroof position (fully-closed or other) by the signals from sunroof motor.

When sunroof motor detects an interruption during the following slide close and tilt down operation, sunroof switch controls the motor for open and the sunroof will operate until it reaches full up position (during tilt down operation) or 125 mm (4.92 in) or more in an open direction (during slide close operation).

- close operation and tilt down when ignition switch is in the ON position.
- close operation and tilt down during retained power operation.

INITIALIZATION FAILURE CONDITIONS

Initialization and teaching of system should be conducted if the following conditions exist:

- sunroof will only move in the UP/CLOSE direction, having a step by step motion
- sunroof does not have any auto operation.

INITIALIZATION PROCEDURE

If the sunroof does not close or open automatically, use the following procedure to return sunroof operation to normal.

1. Press the switch to the UP/CLOSE position to tilt the sunroof up fully. When the sunroof reaches the full tilt up position it will back up a few millimeters and stop.
2. Release the UP/CLOSE switch.
3. Within 5 seconds of releasing the UP/CLOSE switch, press and hold the UP/CLOSE switch again. The sunroof will move to the full open position and back to the closed position.

A

B

C

D

E

F

G

H

RF

J

K

L

M

SUNROOF

NOTE:

If the UP/CLOSE switch is released anytime during this teaching process, all learned profile data will be discarded and the procedure will have to be started over.

4. Release the UP/CLOSE switch. Do not disconnect power for at least two seconds. The sunroof is now initialized and taught.

Initializing procedure is complete. Confirm proper operation of the sunroof (slide open, slide closed, tilt up, tilt down).

RE-TEACHING CONDITIONS

Re-teaching of system should be conducted if any of the following conditions exist:

- the sunroof is manually operated using the sunroof wrench with the battery discharged or disconnected.
- the sunroof is manually operated using the sunroof wrench with the key switch in the OFF position and retained power timed out (after approximately 45 seconds or with a front door open).
- the sunroof motor assembly is replaced with a new one.
- the sunroof motor is removed from the sunroof assembly and operated before it is reinstalled.
- the sunroof motor is removed from the sunroof assembly and the glass panel position is changed.

RE-TEACHING PROCEDURE

1. Using the UP/CLOSE switch, move the sunroof toward the tilt position until it stops.
2. Release the UP/CLOSE switch.
3. Press the UP/CLOSE switch again and continuously hold. The sunroof will begin to move in about 10 seconds.
4. Continue to hold the UP/CLOSE switch while the sunroof moves in a jogging motion to the full tilt position. When the sunroof reaches the full tilt position, it will back up a few millimeters and stop.
5. Release the UP/CLOSE switch.
6. Within 5 seconds of releasing the UP/CLOSE switch, press and hold the UP/CLOSE switch again. The sunroof will move to the full open position and back to the closed position.

NOTE:

If the UP/CLOSE switch is released anytime during this teaching process, all learned profile data will be discarded and the procedure will have to be started over.

7. Release the UP/CLOSE switch. Do not disconnect power for at least two seconds. The sunroof is now re-taught.

CAN Communication System Description

EIS00773

Refer to [LAN-4, "SYSTEM DESCRIPTION"](#) .

SUNROOF

Wiring Diagram — SROOF —

EIS00774

RF-SROOF-01

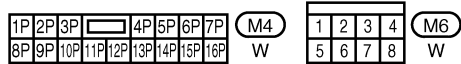
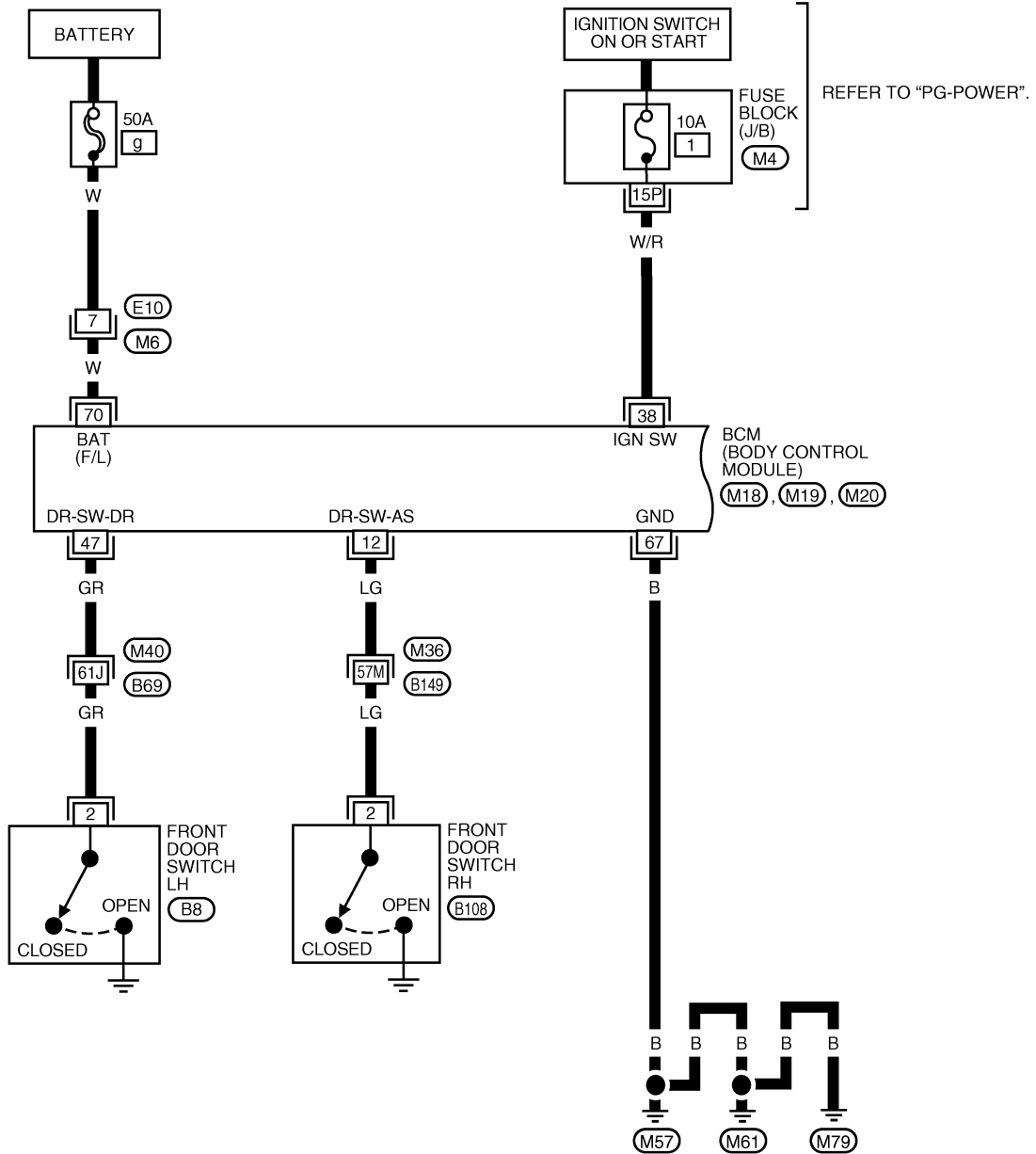

REFER TO THE FOLLOWING.
(M36, M40) - SUPER
MULTIPLE JUNCTION (SMJ)

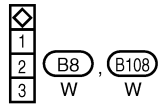
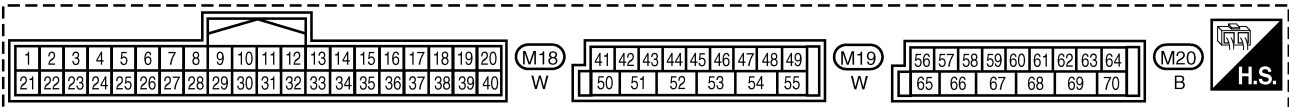

WIWA1594E

SUNROOF

RF-SROOF-02

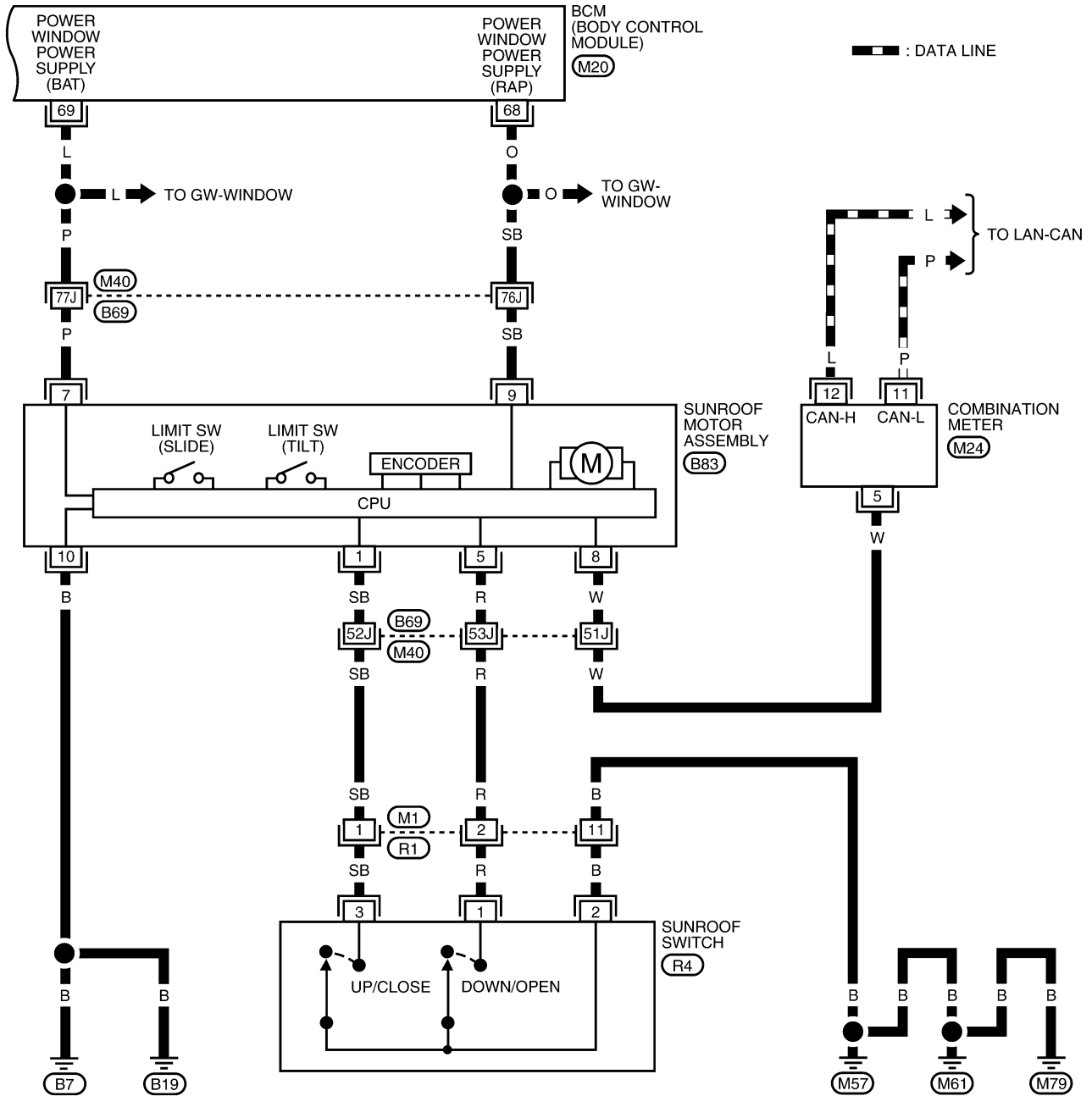

REFER TO THE FOLLOWING.
 (M40) - SUPER MULTIPLE JUNCTION (SMJ)

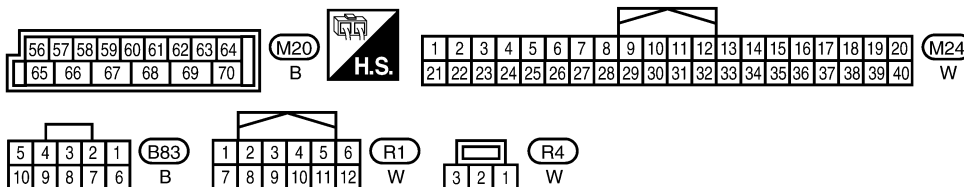

WIWA0521E

SUNROOF

Terminals and Reference Values for BCM

EIS00775

Refer to [BCS-12, "Terminals and Reference Values for BCM"](#) .

Sunroof Motor Assembly Harness Connector Terminal Layout

EIS00BD3

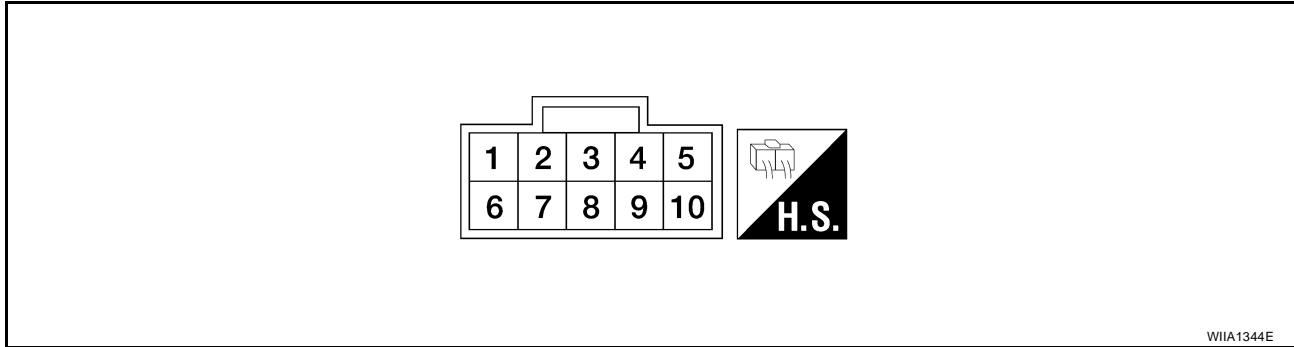

Terminals and Reference Values for Sunroof Motor Assembly

EIS00776

Terminal	Wire color	Item	Condition	Voltage (Approx.)
1	SB	Sunroof switch (UP/CLOSE) signal	Ignition switch ON and sunroof switch in UP/CLOSE position	0
			Ignition switch ON and sunroof switch in OFF position	Battery voltage
5	R	Sunroof switch (DOWN/OPEN) signal	Ignition switch ON and sunroof switch in DOWN/OPEN position	0
			Ignition switch ON and sunroof switch in OFF position	Battery voltage
7	P	BAT power supply	—	Battery voltage
8	W	Vehicle speed signal	Speedometer operated [when vehicle speed is approx. 40 km/h (25 MPH)]	<p>ELF1080D</p>
9	SB	RAP signal	Ignition switch ON	Battery voltage
			Within 45 seconds after ignition switch is turned OFF	Battery voltage
			When front door LH or RH is opened while retained power is operating	0
10	B	Ground	—	0

Work Flow

EIS00777

1. Check the symptom and customer's requests.
2. Understand the outline of system. Refer to [RF-10, "System Description"](#) .
3. According to the trouble diagnosis chart, repair or replace the cause or replace of the malfunction. Refer to [RF-17, "Trouble Diagnosis Chart by Symptom"](#) .
4. Does sunroof system operate normally? If Yes, GO TO 5, If No, GO TO 3.
5. Inspection End.

SUNROOF

CONSULT-II Function (BCM)

EIS0077B

CONSULT-II can display each diagnostic item using the diagnostic test modes shown following.

BCM diagnostic test item	Diagnostic mode	Description
Inspection by part	WORK SUPPORT	Supports inspections and adjustments. Commands are transmitted to the BCM for setting the status suitable for required operation, input/output signals are received from the BCM and received data is displayed.
	DATA MONITOR	Displays BCM input/output data in real time.
	ACTIVE TEST	Operation of electrical loads can be checked by sending drive signal to them.
	SELF-DIAG RESULTS	Displays BCM self-diagnosis results.
	CAN DIAG SUPPORT MNTR	The result of transmit/receive diagnosis of CAN communication can be read.
	ECU PART NUMBER	BCM part number can be read.
	CONFIGURATION	Performs BCM configuration read/write functions.

CONSULT-II START OPERATION

Refer to [GI-38, "CONSULT-II Start Procedure"](#).

Work Support

EIS00779

Work item	Description
RETAINED PWR SET	RAP signal's power supply period can be changed by mode setting. Selects RAP signal's power supply period between the following three steps. <ul style="list-style-type: none"> ● MODE 1 (45 sec.) / MODE 2 (OFF) / MODE 3 (2 min.)

Active Test

EIS0077A

Test item	Description
RETAINED PWR	This test is able to supply RAP signal (power) from BCM to power window system, power sunroof system. Those systems can be operated when turning on "RETAINED PWR" on CONSULT-II screen even if the ignition switch is turned OFF. <p>NOTE: During this test, CONSULT-II can be operated with ignition switch in "OFF" position. "RETAINED PWR" should be turned "ON" or "OFF" on CONSULT-II screen when ignition switch ON. Then turn ignition switch OFF for checking retained power operation. CONSULT-II might be stuck if "RETAINED PWR" is "OFF" on CONSULT-II screen when ignition switch is OFF.</p>

Data Monitor

EIS0077B

Monitored item	Description
IGN ON SW	Indicates [ON/OFF] condition of ignition switch.
DOOR SW-DR	Indicates [ON/OFF] condition of front door switch LH.
DOOR SW-AS	Indicates [ON/OFF] condition of front door switch RH.

SUNROOF

Trouble Diagnosis Chart by Symptom

EIS007TC

Symptom	Diagnostic procedure and repair order	Refer to page
Sunroof does not operate.	1. BCM power supply and ground circuit check	RF-17
	2. Sunroof motor assembly power supply and ground circuit check	RF-19
	3. Sunroof switch system check	RF-17
	4. Replace sunroof motor assembly	RF-25
Motor does not stop at the sunroof fully-open or fully-closed position.	1. Initialization procedure check	RF-11
	2. Replace sunroof motor assembly	RF-25
Retained power operation does not operate properly.	1. Check the retained power operation mode setting	RF-11
	2. BCM power supply and ground circuit check	RF-17
	3. Door switch check	RF-20
	4. Replace sunroof motor assembly	RF-25
Sunroof does not do the interruption detection.	1. Replace sunroof motor assembly	RF-25

BCM Power Supply and Ground Circuit Check

EIS007TD

Refer to [BCS-16, "BCM Power Supply and Ground Circuit Check"](#).

Sunroof Switch System Check

EIS007TE

1. SUNROOF SWITCH INPUT SIGNAL CHECK

- Turn ignition switch ON.
- Check voltage between sunroof motor assembly connector and ground.

Connector	Terminal		Condition	Voltage (Approx.)
	(+)	(-)		
B83	1	Ground	Sunroof switch is operated to UP/CLOSE	0
			Other than above	Battery voltage
	5		Sunroof switch is operated to DOWN/OPEN	0
			Other than above	Battery voltage

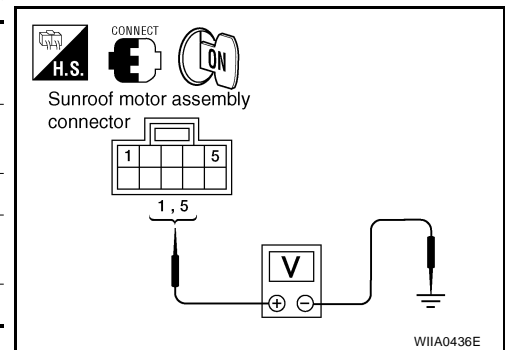

OK or NG

- OK >> Sunroof switch input signal circuits are OK.
 NG >> GO TO 2.

SUNROOF

2. SUNROOF SWITCH CIRCUIT CHECK

1. Turn ignition switch OFF.
2. Disconnect sunroof motor assembly and sunroof switch connectors.
3. Check continuity between sunroof motor assembly connector B83 terminals 1, 5 and sunroof switch connector R4 terminals 1, 3.

1 - 3 : Continuity should exist.

5 - 1 : Continuity should exist.

4. Check continuity between sunroof motor assembly connector B83 terminals 1, 5 and ground.

1 - Ground : Continuity should not exist.

5 - Ground : Continuity should not exist.

OK or NG

OK >> GO TO 3.

NG >> Repair or replace harness between sunroof motor assembly and sunroof switch.

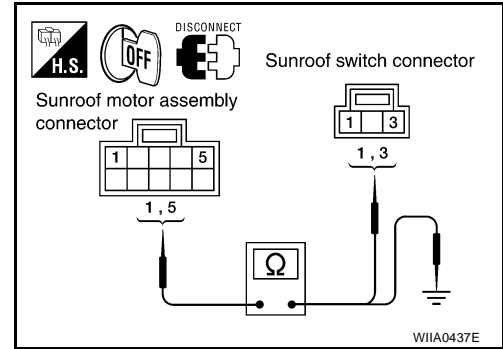

WIA0437E

3. SUNROOF SWITCH GROUND CIRCUIT CHECK

Check continuity between sunroof switch connector R4 terminal 2 and ground.

2 - Ground : Continuity should exist.

OK or NG

OK >> GO TO 4.

NG >> Repair or replace harness.

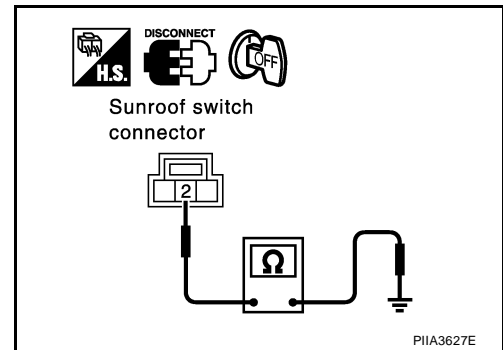

PIA3627E

4. SUNROOF SWITCH CHECK

Check continuity between sunroof switch terminals 1, 3 and 2.

Terminals		Condition	Continuity
1	2	Sunroof switch is operated to DOWN/OPEN	Yes
		Other than above	No
3		Sunroof switch is operated to UP/CLOSE	Yes
		Other than above	No

OK or NG

OK >> Replace sunroof motor assembly. Refer to [RF-25](#), "[SUNROOF MOTOR](#)".

NG >> Replace sunroof switch.

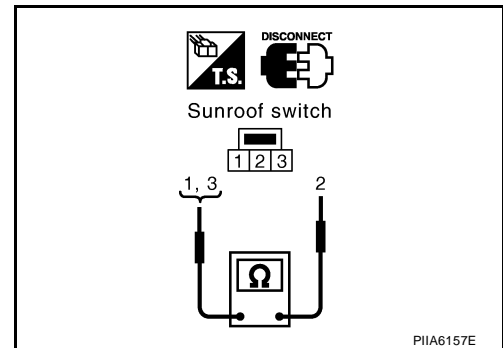

PIA6157E

SUNROOF

EIS007TF

Sunroof Motor Assembly Power Supply and Ground Circuit Check

1. CHECK POWER SUPPLY CIRCUIT

1. Turn ignition switch ON.
2. Check voltage between sunroof motor assembly connector B83 terminals 7, 9 and ground.

7 - Ground : Battery voltage

9 - Ground : Battery voltage

OK or NG

OK >> GO TO 2.

NG >> GO TO 3.

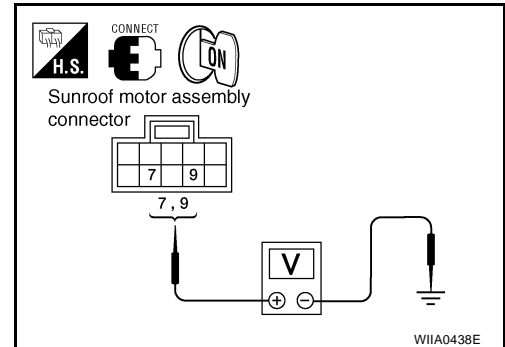

2. CHECK GROUND CIRCUIT

1. Turn ignition switch OFF.
2. Disconnect sunroof motor assembly connector.
3. Check continuity between sunroof motor assembly connector B83 terminal 10 and ground.

10 - Ground : Continuity should exist.

OK or NG

OK >> Sunroof motor assembly power supply and ground circuits are OK. Further inspection is necessary. Refer to [RF-17, "Trouble Diagnosis Chart by Symptom"](#).

NG >> Repair or replace harness.

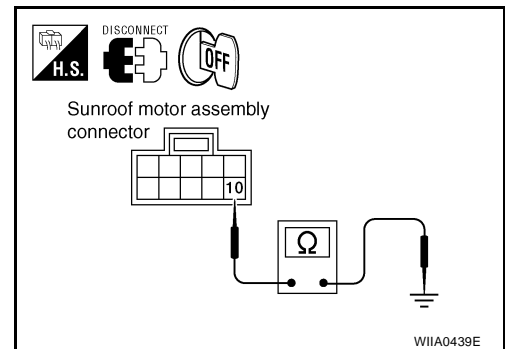

3. CHECK BCM OUTPUT SIGNAL

Check voltage between BCM connector M20 terminals 68, 69 and ground.

68 - Ground : Battery voltage

69 - Ground : Battery voltage

OK or NG

OK >> GO TO 4.

NG >> Replace BCM. Refer to [BCS-25, "Removal and Installation"](#).

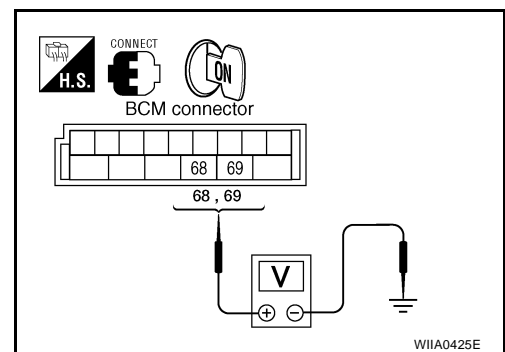

SUNROOF

4. CHECK SUNROOF MOTOR CIRCUIT

- Turn ignition switch OFF.
- Disconnect BCM and sunroof motor assembly connectors.
- Check continuity between BCM connector M20 terminals 68, 69 and sunroof motor assembly connector B83 terminals 7, 9.

68 - 9 : Continuity should exist.

69 - 7 : Continuity should exist.

- Check continuity between BCM connector M20 terminals 68, 69 and ground.

68 - Ground : Continuity should not exist.

69 - Ground : Continuity should not exist.

OK or NG

OK >> Sunroof motor assembly power supply circuits are OK. Further inspection is necessary. Refer to [RF-17, "Trouble Diagnosis Chart by Symptom"](#).

NG >> Repair or replace harness.

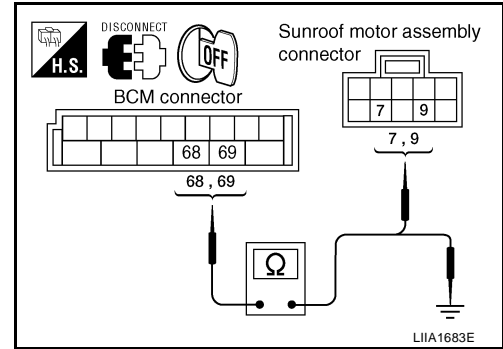

Door Switch Check

EIS007TG

1. CHECK DOOR SWITCH INPUT SIGNAL

With CONSULT-II

Check ("DOOR SW-DR" and "DOOR SW-AS") in "DATA MONITOR" mode with CONSULT-II.

Monitor item	Condition	
DOOR SW-DR	DOOR OPEN	: ON
	DOOR CLOSED	: OFF
DOOR SW-AS	DOOR OPEN	: ON
	DOOR CLOSED	: OFF

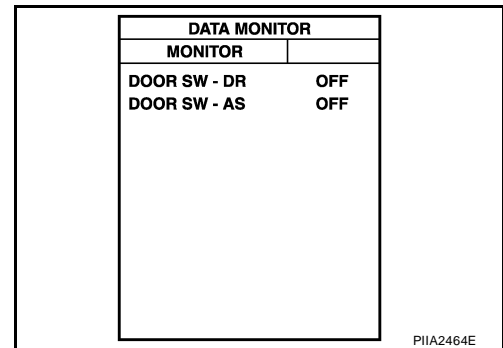

Without CONSULT-II

Check voltage between BCM connector M18, M19 terminals 12, 47 and ground.

Item	Terminal		Condition	Voltage (Approx.)
	(+)	(-)		
RH door switch	12	Ground	DOOR OPEN (Switch closed)	0
			DOOR CLOSED (Switch open)	Battery voltage
LH door switch	47		DOOR OPEN (Switch closed)	0
			DOOR CLOSED (Switch open)	Battery voltage

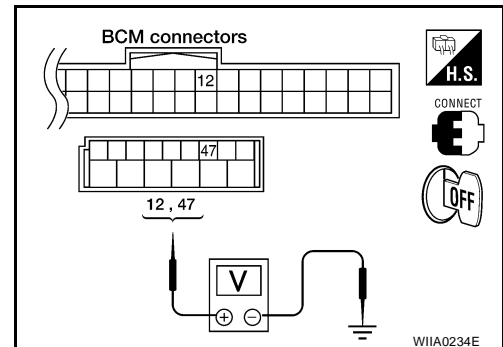

OK or NG

OK >> Door switch circuit is OK.

NG >> GO TO 2.

SUNROOF

2. CHECK DOOR SWITCH CIRCUIT

1. Turn ignition switch OFF.
2. Disconnect door switch and BCM connectors.
3. Check continuity between BCM connector M18, M19 terminals 12, 47 and door switch connectors B8, B108 terminal 2.

Front door LH

47 - 2 : Continuity should exist.

Front door RH

12 - 2 : Continuity should exist.

4. Check continuity between BCM connector M18, M19 terminals 12, 47 and ground.

12 - Ground : Continuity should not exist.

47 - Ground : Continuity should not exist.

OK or NG

OK >> GO TO 3.

NG >> Repair or replace harness.

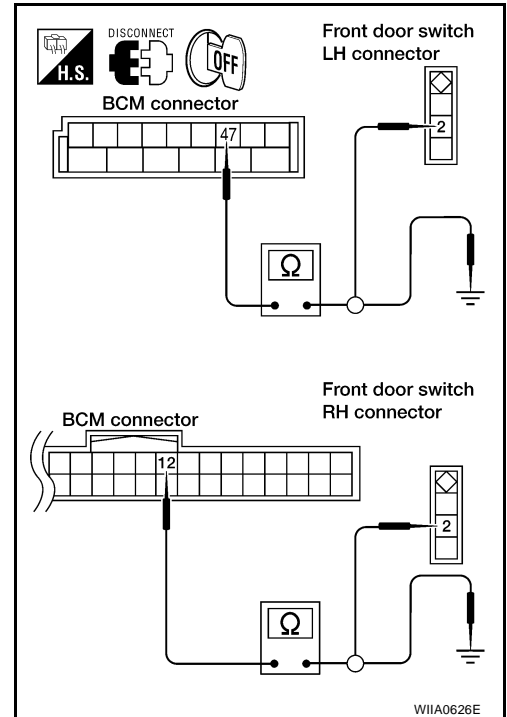

3. CHECK DOOR SWITCH

Check continuity between door switches terminal 2 and ground part of door switch.

Terminal		Door switch	Continuity
2	Ground part of door switch	Pushed	No
		Released	Yes

OK or NG

OK >> GO TO 4.

NG >> Replace malfunctioning door switch.

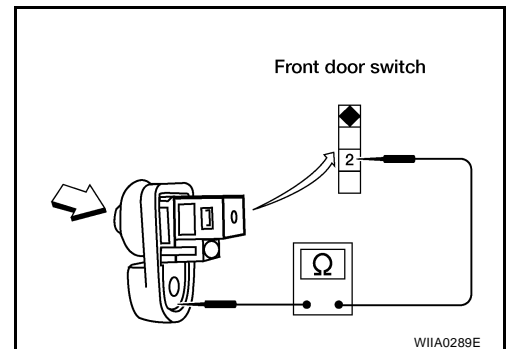

4. CHECK BCM OUTPUT SIGNAL

1. Connect BCM connectors.
2. Check voltage between BCM connector M18, M19 terminals 12, 47 and ground.

12 - Ground : Battery voltage

47 - Ground : Battery voltage

OK or NG

OK >> Further inspection is necessary. Refer to [RF-17, "Trouble Diagnosis Chart by Symptom"](#).

NG >> Replace BCM. Refer to [BCS-25, "Removal and Installation"](#).

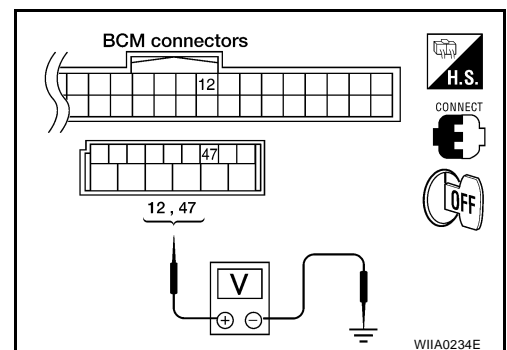

SUNROOF

EIS007TH

Adjustment

Inspect then measure the gap and height difference between the glass lid assembly and roof panel; compare to specifications. Determine which procedure to follow based on results of measurements.

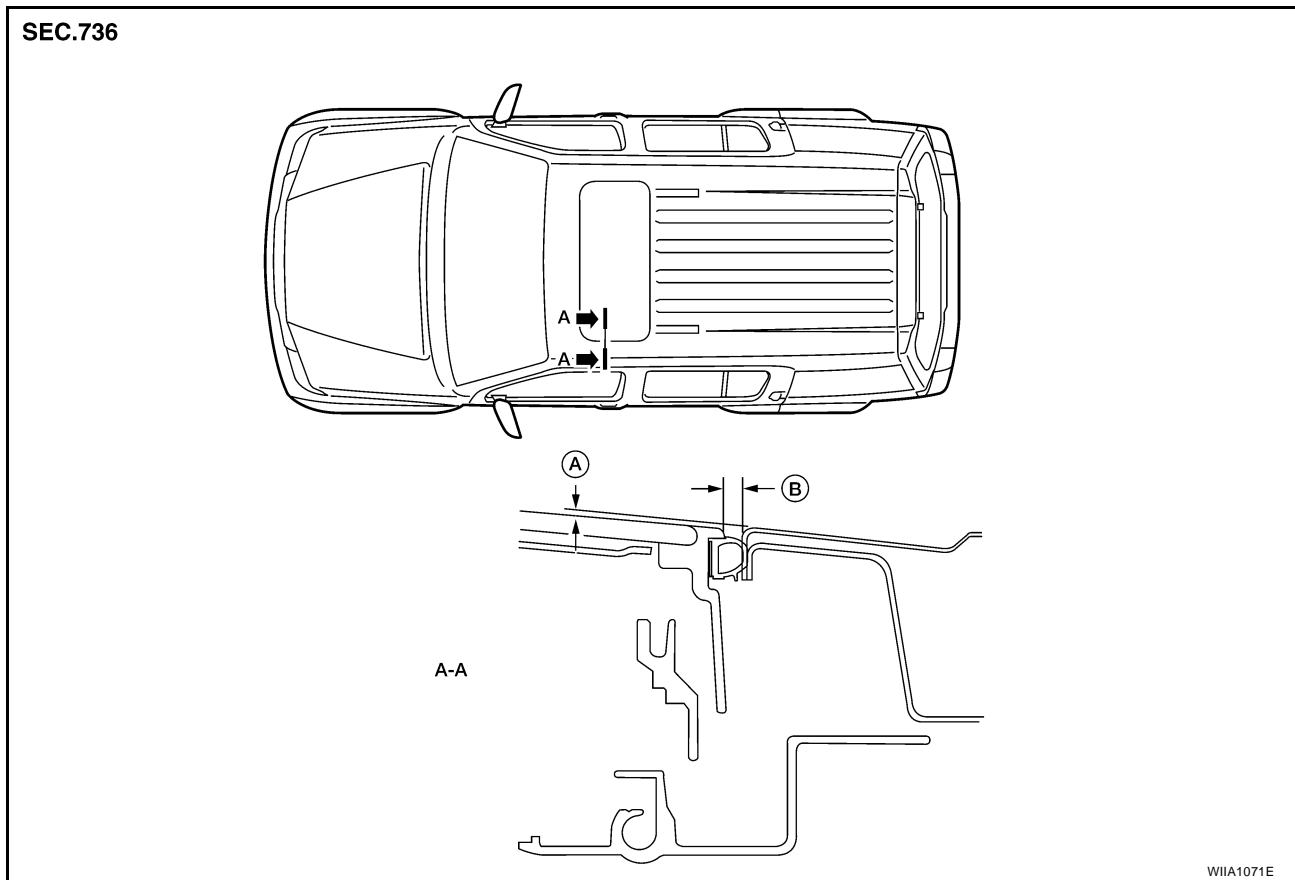

A. $0.8 \pm 1.5\text{mm}$ (0.03 ± 0.06 in.)

B. $4.0 \pm 0.7\text{mm}$ (0.16 ± 0.03 in)

GAP ADJUSTMENT

If a gap or minor height difference between glass lid assembly and roof panel is found, adjust in the following manner:

1. Open sunshade assembly and tilt glass lid assembly up.
2. Loosen glass lid assembly screws (2 each on left and right sides), then tilt glass lid assembly down.
3. Manually adjust glass lid assembly from outside of vehicle so it is within specification "A-A" as shown.
4. After adjustment, tilt glass lid assembly up and tighten screws.
5. Tilt glass lid assembly up and down several times to check that it moves and seals properly.

HEIGHT DIFFERENCE ADJUSTMENT

If an excessive height difference between glass lid assembly and roof panel is found, adjust in the following manner:

1. Remove headlining. Refer to [EI-31, "HEADLINING"](#).
2. Loosen sunroof frame assembly nuts and sunroof bracket bolts.
3. Add shims until gap is within specification "A-A" as shown.

NOTE:

Temporarily snug nuts and bolts to prevent movement between each adjustment.

4. Tilt glass lid assembly up and down several times to check that it moves and seals properly.
5. Tighten sunroof frame assembly nuts and sunroof bracket bolts.

NOTE:

First tighten left front then right rear sunroof frame assembly nuts to prevent uneven torque while tightening remaining sunroof bracket bolts.

6. Install headlining. Refer to [EI-31, "HEADLINING"](#).

SUNROOF

Removal and Installation

EIS007T1

SEC. 736

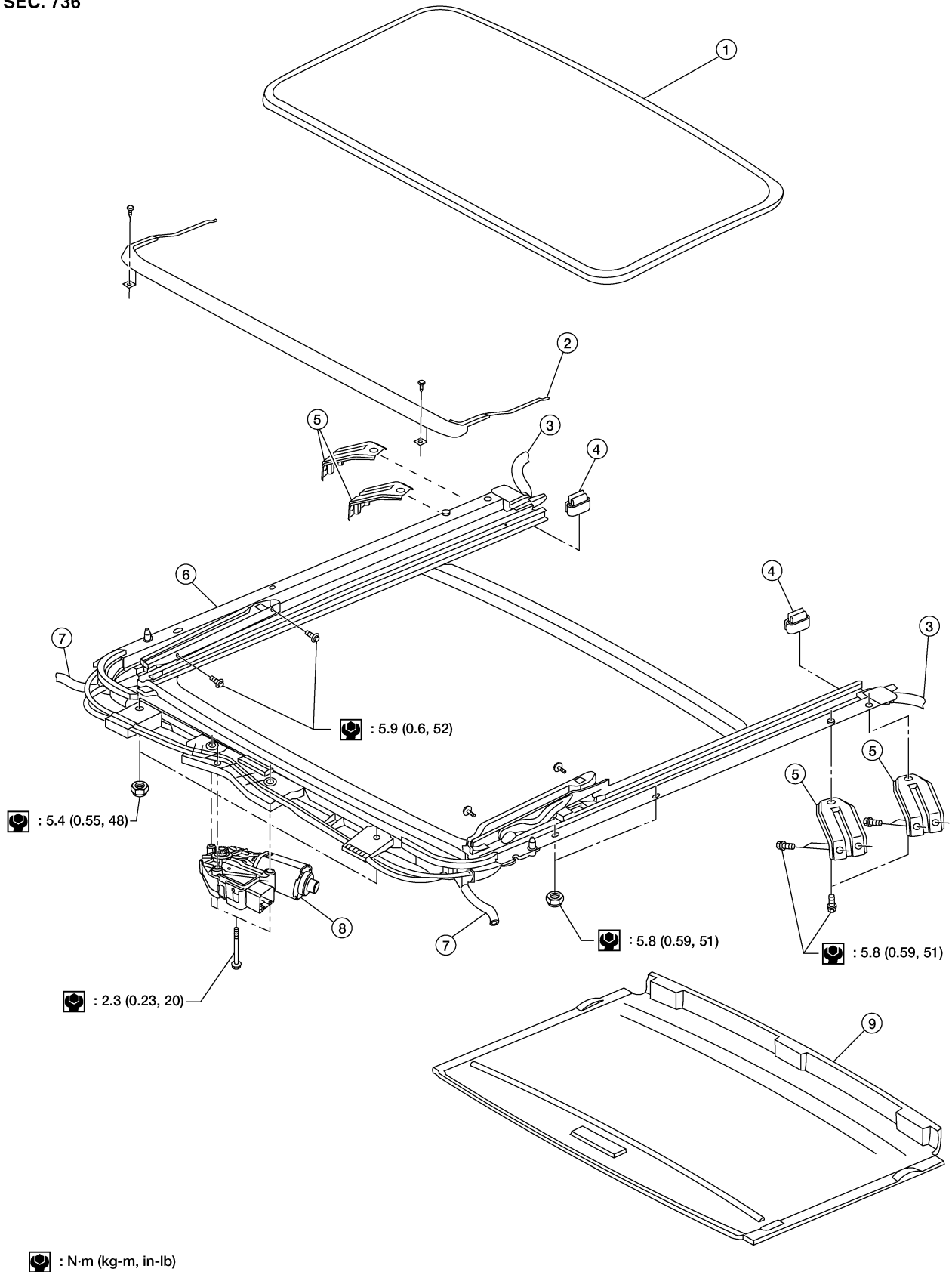

A
B
C
D
E
F
G
H
RF
J
K
L
M

SUNROOF

- | | | |
|-----------------------|---------------------------|---------------------------|
| 1. Glass lid assembly | 2. Wind deflector | 3. Rear drain hoses |
| 4. Shade stoppers | 5. Sunroof bracket | 6. Sunroof frame assembly |
| 7. Front drain hoses | 8. Sunroof motor assembly | 9. Sunshade assembly |

- After any adjustment, check sunroof operation and glass lid alignment.
- Handle glass lid with care so not to cause damage.
- For easier installation, mark each point before removal.

CAUTION:

- **Always work with a helper.**
- **Before removal, fully close the glass lid assembly. Then, after removal, do not move the motor assembly.**
- **After installing the sunroof and glass lid, check gap adjustment to ensure there is no malfunction.**

SUNROOF UNIT

Removal

CAUTION:

- **Always work with a helper.**
- **When taking sunroof unit out, use shop cloths to protect the seats and trim from damage.**
- **After installing the sunroof unit and glass lid, be sure to check gap adjustment to ensure there is no malfunction.**

1. Remove headlining. Refer to [EI-31, "Removal and Installation"](#) .
2. Remove the sunroof glass lid. Refer to [RF-24, "GLASS LID"](#) .
3. Disconnect sunroof motor and remove the overhead console bracket.
4. Disconnect the drain hoses.
5. Remove front sunroof frame assembly nuts.
6. Remove the rear sunroof bracket bolts.
7. Remove the side bolts and the sunroof unit.

Installation

1. Position the sunroof frame assembly and install the side bolts.
2. Install the rear sunroof bracket bolts.
3. Install front sunroof frame assembly nuts.
4. Connect the drain hoses.
5. Install the overhead console bracket and connect the sunroof motor.
6. Install the sunroof glass lid. Refer to [RF-24, "GLASS LID"](#) .
7. Install headlining. Refer to [EI-31, "Removal and Installation"](#) .

GLASS LID

Removal

1. Open sunshade.
2. Ensure glass lid is closed.
3. Remove the screws securing glass lid to the sunroof frame assembly.
4. Remove the glass lid assembly.

Installation

1. Position glass lid to sunroof assembly.

SUNROOF

2. Install the glass lid assembly screws. (First tighten left front bolt, then tighten right rear bolt on glass lid to prevent lid from moving while tightening other bolts.)
3. Adjust the sunroof glass. Refer to [RF-22, "Adjustment"](#) .

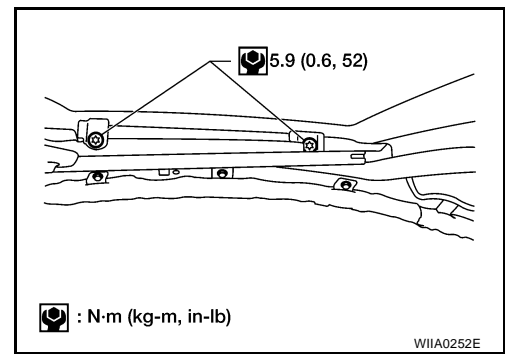

WIND DEFLECTOR

Removal

1. Open the sunroof.
2. Remove screws from the left, center, and right side wind deflector holders.
3. Remove the wind deflector from the sunroof frame assembly.

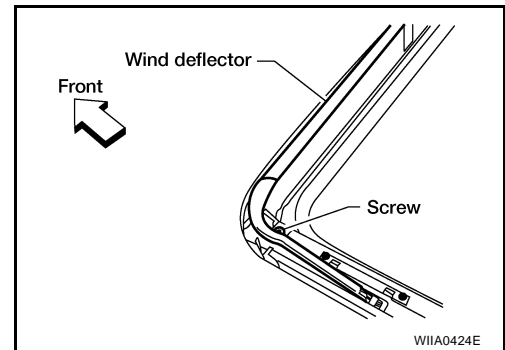

Installation

Installation is in the reverse order of removal.

SUNSHADE

Removal

1. Remove the sunroof frame assembly. Refer to [RF-24, "SUNROOF UNIT"](#) .
2. Remove the sunshade stoppers (2 points) from the rear end of the sunroof frame assembly.
3. Remove the sunshade assembly from the rear end of the sunroof frame assembly.

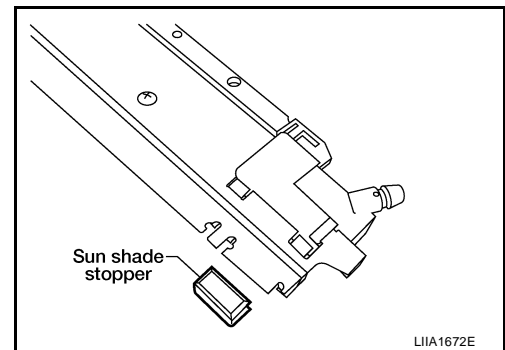

Installation

Installation is in the reverse order of removal.

SUNROOF MOTOR

Removal

CAUTION:

- When removing the sunroof motor, be sure that the sunroof is in the fully closed position.
 - Never run the removed motor as a single unit.
1. Position the sunroof assembly in the fully closed position.
 2. Remove the front roof console assembly. Refer to [EI-31, "Removal and Installation"](#) .

A
B
C
D
E
F
G
H
RF
J
K
L
M

SUNROOF

3. Disconnect the harness connector from the sunroof motor assembly.
4. Remove the mounting screws and the sunroof motor assembly.

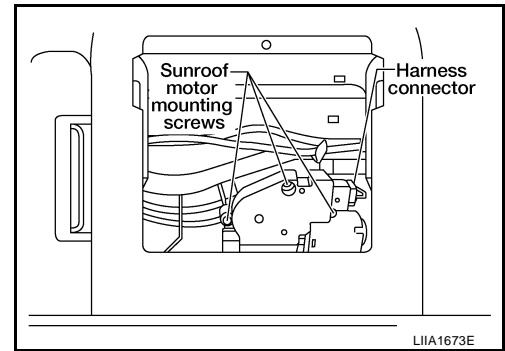

Installation

CAUTION:

Before installing the sunroof motor assembly, be sure to place the link and wire assembly in the symmetrical and fully closed position.

1. Move the sunroof motor assembly laterally little by little so that the gear is completely engaged into the wire on the sunroof unit and the mounting surface becomes parallel. Then secure the motor with bolts.
2. Connect the harness connector to the sunroof motor assembly.

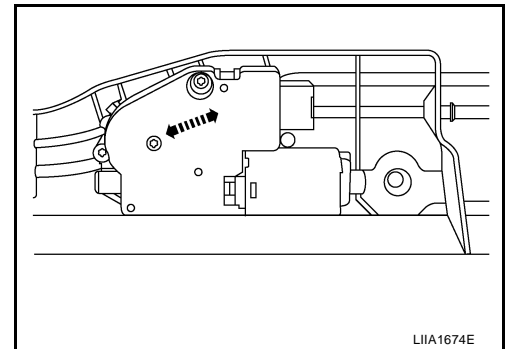

3. Install the front roof console assembly. Refer to [EI-31, "Removal and Installation"](#) .
4. Reset the sunroof motor memory. Refer to [RF-12, "RE-TEACHING PROCEDURE"](#) .

DRAIN HOSES

Removal

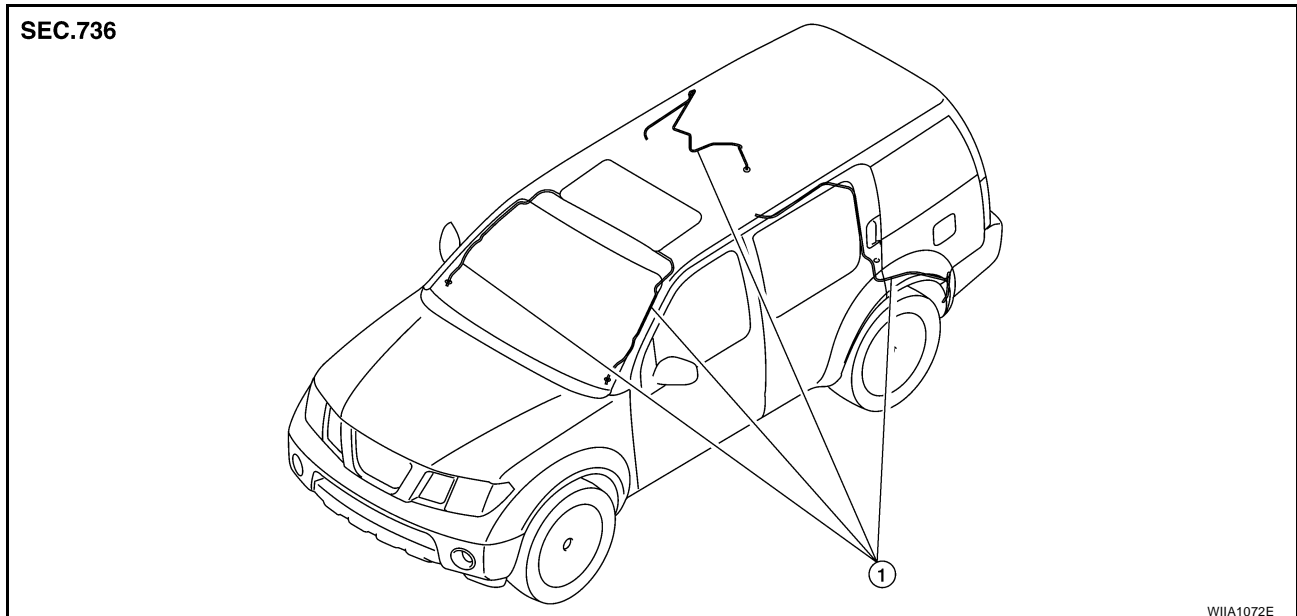

1. Drain hoses

SUNROOF

1. Remove the headlining. Refer to [EI-31, "Removal and Installation"](#).

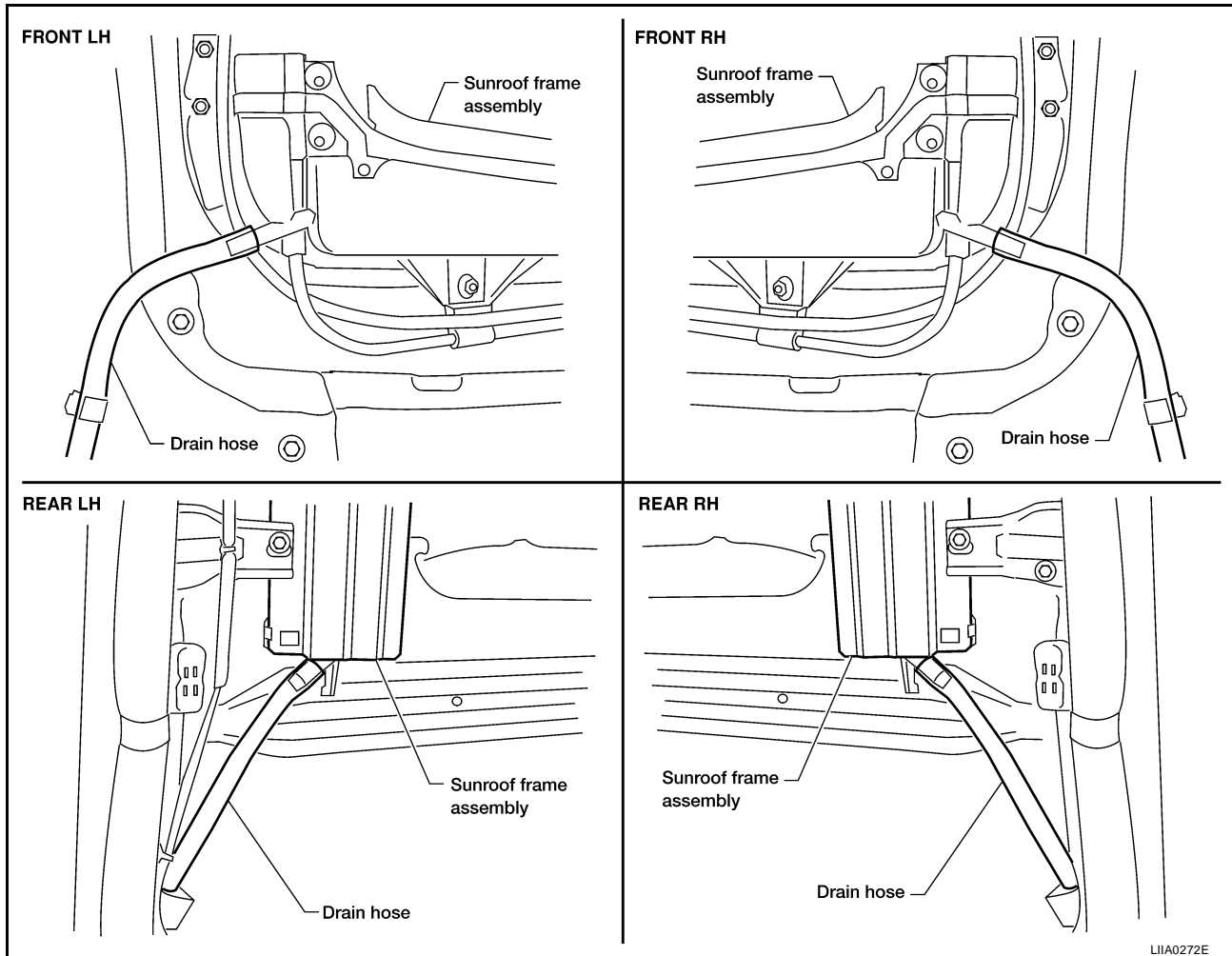

2. Visually check the drain hoses for proper connections, damage or deterioration.
3. Remove each drain hose and check visually for damage, cracks or deterioration.
4. Pour water through the drain hose to check for damage.
 - If any damage is found, replace the drain hose.

Installation

Installation is in the reverse order of removal.

WEATHERSTRIP

Visually check weatherstrip for any damage, deterioration, or flattening.

- In the case of leakage around glass lid, close glass lid and pour water around it to find the damaged or gaped portion, remove glass lid assembly. Refer to: [RF-24, "Removal"](#).
- If any damage is found, replace glass lid assembly. Refer to: [RF-24, "GLASS LID"](#).

CAUTION:

Do not remove weatherstrip.

LINK AND WIRE ASSEMBLY

NOTE:

Before replacing any suspect part, be sure it is the source of the noise.

1. Visually check to determine if a sufficient amount of petroleum jelly has been applied to the wire or rail groove. If not, add petroleum jelly as required.
2. Check wire for any damage or deterioration. If any damage is found, remove rear guide, then replace wire.

SUNROOF
