

SECTION **FSU**  
FRONT SUSPENSION

A  
B  
C  
D

FSU

CONTENTS

<b>PRECAUTIONS</b> .....	<b>2</b>	<b>STABILIZER BAR</b> .....	<b>12</b>	<b>F</b>
Precautions .....	2	Removal and Installation .....	12	
<b>PREPARATION</b> .....	<b>3</b>	REMOVAL .....	12	
Special Service Tools .....	3	INSPECTION AFTER REMOVAL .....	12	<b>G</b>
Commercial Service Tools .....	3	INSTALLATION .....	12	
<b>NOISE, VIBRATION, AND HARSHNESS (NVH)</b>		<b>UPPER LINK</b> .....	<b>13</b>	<b>H</b>
<b>TROUBLESHOOTING</b> .....	<b>4</b>	Removal and Installation .....	13	
NVH Troubleshooting Chart .....	4	REMOVAL .....	13	
<b>FRONT SUSPENSION ASSEMBLY</b> .....	<b>5</b>	INSPECTION AFTER REMOVAL .....	13	
Components .....	5	INSTALLATION .....	13	<b>I</b>
<b>ON-VEHICLE SERVICE</b> .....	<b>6</b>	<b>LOWER LINK</b> .....	<b>14</b>	
Front Suspension Parts .....	6	Removal and Installation .....	14	
Front Wheel Alignment .....	6	REMOVAL .....	14	
PRELIMINARY INSPECTION .....	6	INSPECTION AFTER REMOVAL .....	14	<b>J</b>
GENERAL INFORMATION AND RECOMMEN-		INSTALLATION .....	14	
DATIONS .....	6	<b>UPPER BALL JOINT AND LOWER BALL JOINT...</b>	<b>15</b>	<b>K</b>
THE ALIGNMENT PROCESS .....	7	Removal and Installation .....	15	
CAMBER AND CASTER .....	7	Inspection .....	15	
TOE-IN .....	8	SWINGING FORCE .....	15	
FRONT WHEEL TURNING ANGLE .....	9	TURNING FORCE .....	15	
<b>COIL SPRING AND SHOCK ABSORBER</b> .....	<b>10</b>	VERTICAL END PLAY .....	16	<b>L</b>
Removal and Installation .....	10	<b>KNUCKLE</b> .....	<b>17</b>	
REMOVAL .....	10	On-Vehicle Inspection and Service .....	17	
INSTALLATION .....	10	Removal and Installation .....	17	<b>M</b>
Disassembly and Assembly .....	10	REMOVAL .....	17	
DISASSEMBLY .....	10	INSPECTION AFTER REMOVAL .....	18	
INSPECTION AFTER DISASSEMBLY .....	10	INSTALLATION .....	19	
ASSEMBLY .....	11	<b>SERVICE DATA AND SPECIFICATIONS (SDS) .....</b>	<b>20</b>	
		General Specifications (Front) .....	20	
		Wheel Alignment (Unladen* <sup>1</sup> ) *6 .....	20	
		Ball Joint .....	21	
		Wheelarch Height (Unladen* <sup>1</sup> ) .....	21	

# PRECAUTIONS

---

## PRECAUTIONS

PF0:00001

### Precautions

EES0019K

- When installing the rubber bushings, the final tightening must be done under unladen condition and with the tires on level ground. Oil will shorten the life of the rubber bushings, so wipe off any spilled oil immediately.
- Unladen condition means the fuel tank, engine coolant and lubricants are at the full specification. The spare tire, jack, hand tools, and mats are in their designated positions.
- After installing suspension components, check the wheel alignment.
- Lock nuts are not reusable. Always use new lock nuts for installation. New lock nuts are pre-oiled, do not apply any additional lubrication.

# PREPARATION

## PREPARATION

PF0:00002

### Special Service Tools

EES0019L

The actual shapes of Kent-Moore tools may differ from those of special service tools illustrated here.

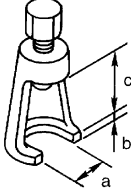
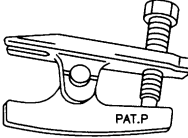
Tool number (Kent-Moore No.) Tool name	Description
ST29020001 (J-24319-01) Gear arm puller   NT694	Removing ball joint for knuckle <b>a: 34 mm (1.34 in)</b> <b>b: 6.5 mm (0.256 in)</b> <b>c: 61.5 mm (2.421 in)</b>
HT72520000 (J-25730-A) Ball joint remover   NT146	Removing tie-rod outer end

A  
B  
C  
D  
**FSU**  
F  
G  
H  
I  
J  
K  
L  
M

### Commercial Service Tools

EES0019M

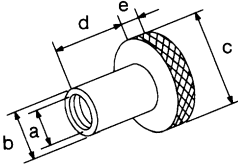
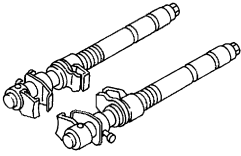
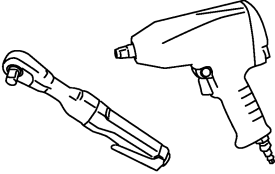
Tool name	Description
Attachment wheel alignment   NT148	Measuring wheel alignment <b>a: Screw M24 x 1.5 pitch</b> <b>b: 35 mm (1.38 in) dia.</b> <b>c: 65 mm (2.56 in) dia.</b> <b>d: 56 mm (2.20 in)</b> <b>e: 12 mm (0.47 in)</b>
Spring compressor   NT717	Removing and installing coil spring
Power tool   PBIC0190E	Loosening bolts and nuts

# NOISE, VIBRATION, AND HARSHNESS (NVH) TROUBLESHOOTING

## NOISE, VIBRATION, AND HARSHNESS (NVH) TROUBLESHOOTING

PF0:00003

### NVH Troubleshooting Chart

EES0019N

Use the chart below to help you find the cause of the symptom. Repair or replace parts as necessary.

		Possible Cause and SUSPECTED PARTS														
		Improper installation, looseness	Shock absorber deformation, damage or deflection	Bushing or mounting deterioration	Parts interference	Spring fatigue	Suspension looseness	Incorrect wheel alignment	Stabilizer bar fatigue	DRIVE SHAFT	DIFFERENTIAL	WHEEL HUB AND BEARING	TIRES	ROAD WHEEL	BRAKES	STEERING
Symptom	Noise	x	x	x	x	x	x			x	x	x	x	x	x	x
	Shake	x	x	x	x		x			x		x	x	x	x	x
	Vibration	x	x	x	x	x				x		x	x			x
	Shimmy	x	x	x	x			x				x	x	x	x	x
	Shudder	x	x	x								x	x	x	x	x
	Poor quality ride or handling	x	x	x	x	x		x	x			x	x	x		
Reference page		<a href="#">FSU-5</a>	<a href="#">FSU-10</a>	<a href="#">FSU-5</a>	<a href="#">FSU-5</a>	<a href="#">FSU-21</a>	<a href="#">FSU-6</a>	<a href="#">FSU-6</a>	<a href="#">FSU-6</a>	<a href="#">FAX-4, "NVH Troubleshooting Chart"</a>	<a href="#">FFD-6, "NVH Troubleshooting Chart"</a>	<a href="#">FAX-4, "NVH Troubleshooting Chart"</a>	<a href="#">WT-3, "NVH Troubleshooting Chart"</a>	<a href="#">WT-3, "NVH Troubleshooting Chart"</a>	<a href="#">BR-5, "NVH Troubleshooting Chart"</a>	<a href="#">PS-5, "NVH Troubleshooting Chart"</a>

x: Applicable

# FRONT SUSPENSION ASSEMBLY

## FRONT SUSPENSION ASSEMBLY

PFP:54010

### Components

EES00190

SEC. 391 • 400 • 401

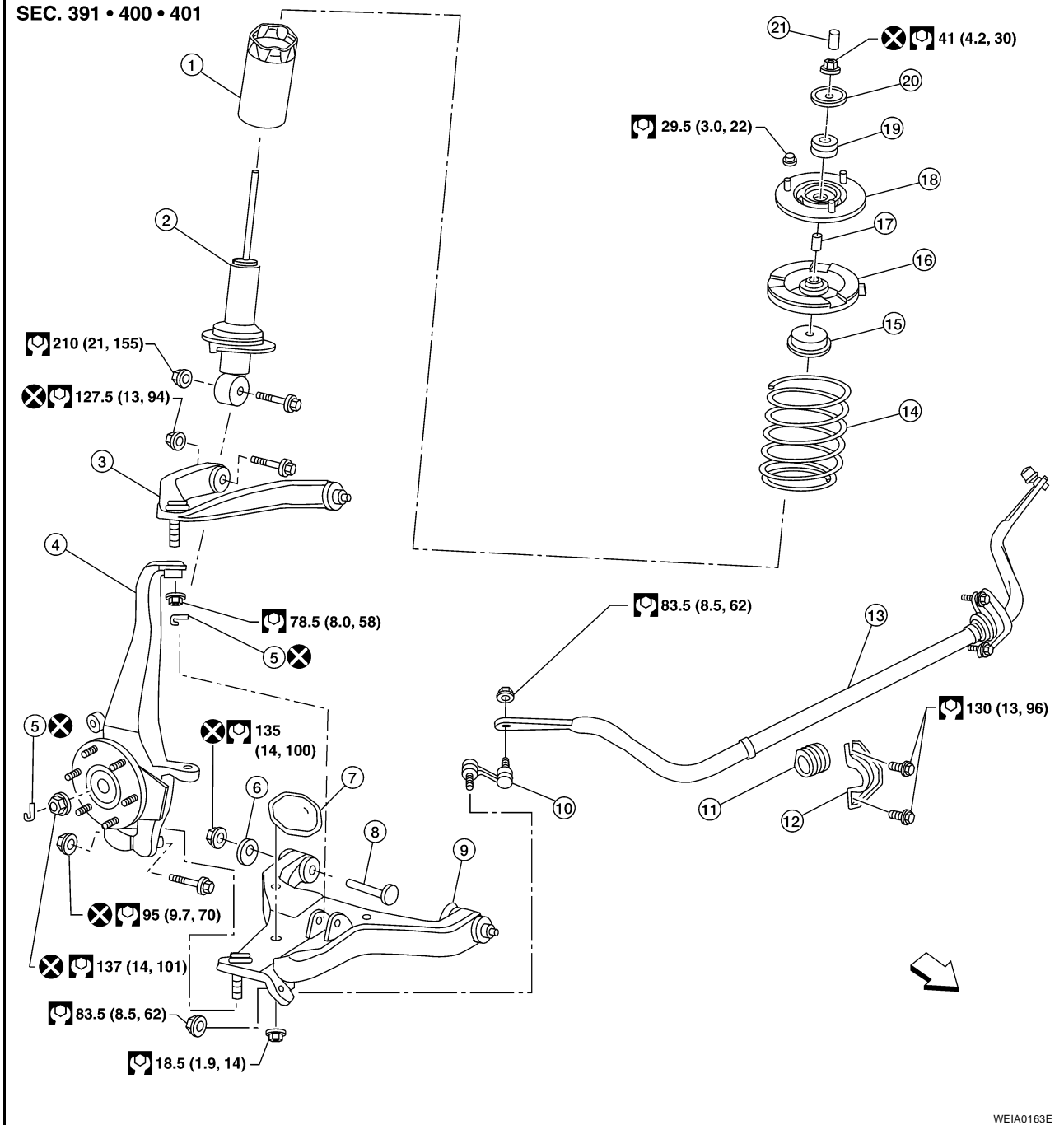

- |                       |                            |                                       |
|-----------------------|----------------------------|---------------------------------------|
| 1. Dust cover         | 2. Shock absorber          | 3. Upper link                         |
| 4. Steering knuckle   | 5. Cotter pin              | 6. Washer                             |
| 7. Jounce bumper      | 8. Bolt                    | 9. Lower link                         |
| 10. Connecting rod    | 11. Stabilizer bar bushing | 12. Stabilizer bar bracket            |
| 13. Stabilizer bar    | 14. Coil spring            | 15. Dust cover cap                    |
| 16. Upper spring seat | 17. Spacer                 | 18. Shock absorber mounting insulator |
| 19. Spacer            | 20. Washer                 | 21. Cap                               |
- ← Front

WEIA0163E

## ON-VEHICLE SERVICE

PFP:00000

### Front Suspension Parts

EES0019P

Check front suspension parts for excessive play, cracks, wear and other damage.

- Shake each front wheel to check for excessive play. If looseness is noted:
  - inspect wheel bearing end play. Refer to [FAX-5, "WHEEL BEARING INSPECTION"](#).
  - check ball joint end play. Refer to [FSU-15, "Inspection"](#).
- Make sure that the cotter pin is inserted in drive shaft end (4WD only).
- Retighten all nuts and bolts to the specified torque.

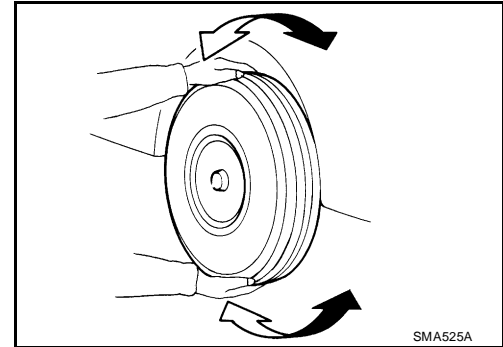

**Suspension component torques** : Refer to [FSU-5, "Components"](#).

- Check shock absorber for oil leakage and other damage.
- Check suspension ball joint for grease leakage and ball joint dust cover for cracks and other damage.

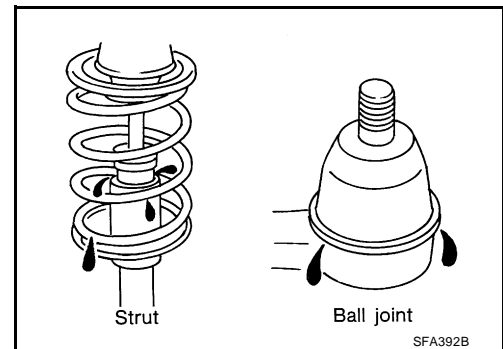

### Front Wheel Alignment PRELIMINARY INSPECTION

EES0019Q

**WARNING:**

**Always adjust the alignment with the vehicle on a flat surface.**

**NOTE:**

If alignment is out of specification, inspect and replace any damaged or worn rear suspension parts before making any adjustments.

1. Check and adjust the wheel alignment with the vehicle under unladen conditions. "Unladen conditions" means that the fuel, coolant, and lubricant are full; and that the spare tire, jack, hand tools and mats are in their designated positions.
2. Check the tires for incorrect air pressure and excessive wear.
3. Check the wheels for run out and damage. Refer to [WT-4, "Inspection"](#).
4. Check the wheel bearing axial end play. Refer to [FAX-5, "WHEEL BEARING INSPECTION"](#).
5. Check the shock absorbers for leaks or damage.
6. Check each mounting point of the suspension components for any excessive looseness or damage.
7. Check each link, arm, and the suspension member for any damage.
8. Check the vehicle height. Refer to [FSU-21, "Wheelarch Height \(Unladen\\*1\)"](#).

### GENERAL INFORMATION AND RECOMMENDATIONS

1. A Four-Wheel Thrust Alignment should be performed.
  - This type of alignment is recommended for any NISSAN vehicle.
  - The four-wheel "thrust" process helps ensure that the vehicle is properly aligned and the steering wheel is centered.
  - The alignment machine itself should be capable of accepting any NISSAN vehicle.
  - The alignment machine should be checked to ensure that it is level.
2. Make sure the alignment machine is properly calibrated.

# ON-VEHICLE SERVICE

- Your alignment machine should be regularly calibrated in order to give correct information.
- Check with the manufacturer of your specific alignment machine for their recommended Service/Calibration Schedule.

## THE ALIGNMENT PROCESS

**IMPORTANT:** Use only the alignment specifications listed in this Service Manual. Refer to [FSU-20, "Wheel Alignment \(Unladen\\*1\)\\*6"](#).

1. When displaying the alignment settings, many alignment machines use "indicators": (Green/red, plus or minus, Go/No Go). **Do NOT use these indicators.**
  - The alignment specifications programmed into your alignment machine that operate these indicators may not be correct.
  - This may result in an ERROR.
2. Some newer alignment machines are equipped with an optional "Rolling Compensation" method to "compensate" the sensors (alignment targets or head units). **Do NOT use this "Rolling Compensation" method.**
  - Use the "Jacking Compensation" method. After installing the alignment targets or head units, raise the vehicle and rotate the wheels 1/2 turn both ways.
  - See Instructions in the alignment machine you are using for more information.

## CAMBER AND CASTER

1. Measure camber and caster of both the right and left wheels with a suitable alignment gauge and adjust as necessary to specification.

**Camber** : Refer to [FSU-6, "Front Wheel Alignment"](#).

**NOTE:**

Some vehicles may be equipped with straight (non-adjustable) lower link bolts and washers. In order to adjust camber and caster on these vehicles, first replace the lower link bolts and washers with adjustable (cam) bolts and washers.

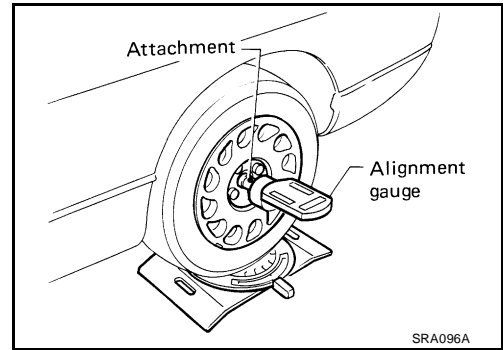

2. If outside of the specified value, adjust camber and caster using the adjusting bolts in the front lower link.

**CAUTION:**

**After adjusting the camber then check the toe-in.**

**NOTE:**

Camber changes about 3' (0.05°) minutes with each graduation of one adjusting bolt. Refer to table below for examples of lower link adjusting bolt effect on camber and caster.

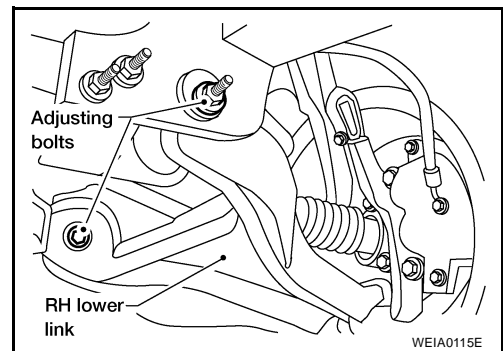

Rear adjusting bolt	1 In	1 Out	1 In	1 Out	0	0	1 In	1 Out
Front adjusting bolt	1 Out	1 In	1 In	1 Out	1 In	1 Out	0	0
Camber Degree minute (Decimal degree)	0 (0)	0 (0)	7' (0.12°)	- 7' (-0.12°)	3' (0.05°)	- 3' (-0.05°)	3' (0.05°)	- 3' (-0.05°)
Caster Degree minute (Decimal degree)	- 12' (0.20°)	12' (0.20°)	0 (0)	0 (0)	6' (0.10°)	- 6' (0.10°)	- 6' (0.10°)	6' (0.10°)

3. Tighten the adjusting bolt nuts to specification. Refer to [FSU-5, "Components"](#).

# ON-VEHICLE SERVICE

## TOE-IN

### WARNING:

- Always perform the following procedure on a flat surface.
  - Make sure that no person is in front of the vehicle before pushing it.
1. Bounce the front of vehicle up and down to stabilize the vehicle height (posture).
  2. Push the vehicle straight ahead about 5 m (16 ft).
  3. Put a mark on base line of the tread (rear side) of both front tires at the same height as hub center as shown. These marks are measuring points.

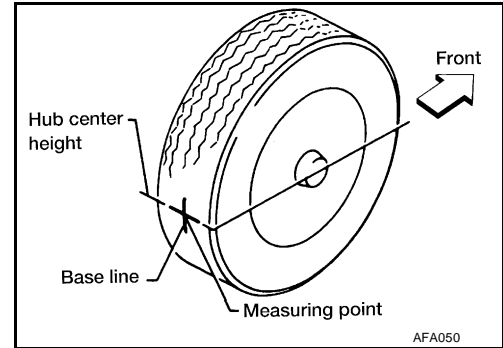

4. Measure the distance "A" on the rear side of the front tires as shown.
5. Push the vehicle slowly ahead to rotate the wheels 180° degrees (1/2 a turn).

### CAUTION:

If the wheels have rotated more than 180° degrees (1/2 turn), start this procedure again from the beginning. Never push the vehicle backward.

6. Measure the distance "B" on the front side of the front tires at the same marks as shown. Total toe-in is calculated as "A" – "B".

**Total toe-in** : Refer to [FSU-20, "Wheel Alignment \(Unladen\\*1\)\\*6"](#) .

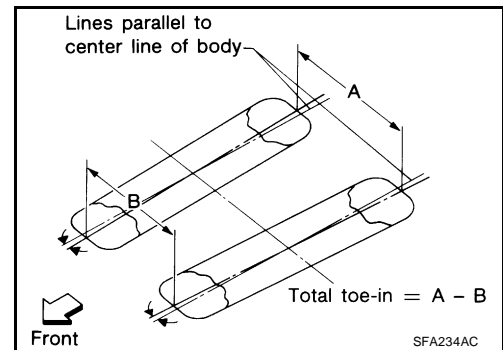

7. Adjust the toe-in by varying the length of the steering outer tie-rods.
  - a. Loosen the outer tie-rod lock nuts.
  - b. Adjust the toe-in by screwing the outer tie-rods in or out.

**Standard length "L"** : Refer to [PS-15, "POWER STEERING GEAR AND LINK-AGE"](#) .

- c. Tighten the outer tie-rod lock nuts to specification.

**Lock nut** : Refer to [PS-15, "Removal and Installation"](#) .

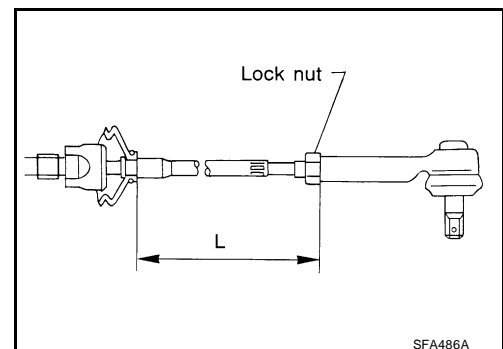



# ON-VEHICLE SERVICE

## FRONT WHEEL TURNING ANGLE

### NOTE:

Check front wheel turning angle after the toe-in inspection.

1. Place front wheels on turning radius gauges in straight ahead position and rear wheels on stands so that vehicle can be level. Check the maximum inner and outer wheel turning angles for LH and RH road wheels.
2. Start engine and run at idle, turn steering wheel all the way right and left, measure the turning angle.

**Wheel turning angle (full turn)** : Refer to **FSU-20, "Wheel Alignment (Unladen\*1)\*6"**

- Any turning angles are not adjustable. If any of steering angles are out of the specification, check if the following parts are worn or damaged.
  - Steering gear
  - Steering column
  - Front suspension componentsIf found that they are worn or damaged, replace them with new ones.

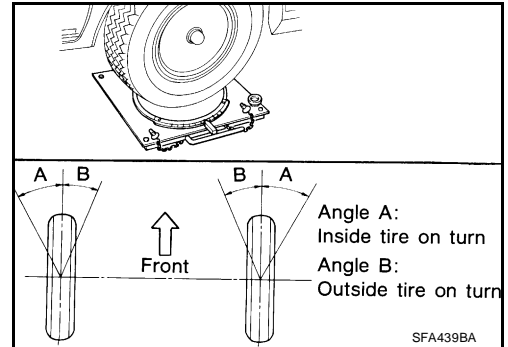

A  
B  
C  
D  
FSU  
F  
G  
H  
I  
J  
K  
L  
M

# COIL SPRING AND SHOCK ABSORBER

## COIL SPRING AND SHOCK ABSORBER

PFP:56210

### Removal and Installation REMOVAL

EES0019R

1. Remove the wheel and tire using power tool.
2. Support the lower link using a suitable jack.
3. Remove connecting rod upper joints from stabilizer bar using power tool. Refer to [FSU-5, "Components"](#).
  - Swing stabilizer bar down, repositioning it out of the way to access shock absorber lower mount.
4. Remove the shock absorber lower bolt and nut using power tool.
5. Remove the three shock absorber upper mounting nuts using power tool.
6. Remove the coil spring and shock absorber assembly.
  - Turn steering knuckle out to gain enough clearance for removal.

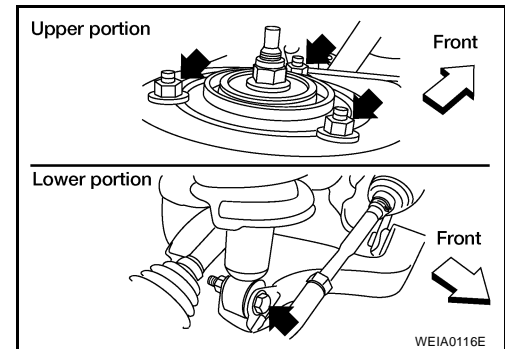

### INSTALLATION

Installation is in the reverse order of removal.

- The step in the strut assembly lower seat faces outside of vehicle.
- Tighten all nuts and bolts to specification. Refer to [FSU-5, "Components"](#).
- When installing wheel and tire, refer to [WT-6, "Rotation"](#).

### Disassembly and Assembly DISASSEMBLY

EES0019S

1. Set the shock absorber in a vise, then loosen (without removing) the piston rod lock nut as shown.

#### **CAUTION:**

**Do not remove piston rod lock nut at this time.**

2. Compress the spring using commercial service tool until the shock absorber mounting insulator can be turned by hand.

#### **WARNING:**

**Make sure that the pawls of the two spring compressors are firmly hooked on the spring. The spring compressors must be tightened alternately and evenly so as not to tilt the spring.**

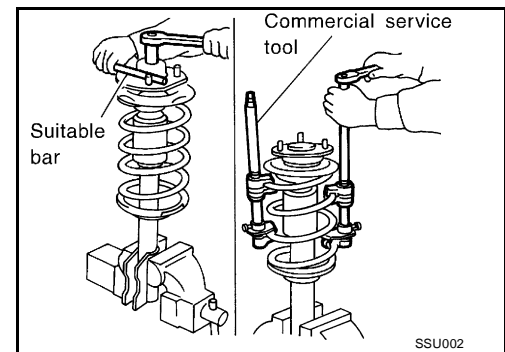

3. Remove the piston rod lock nut.
  - Discard the piston rod lock nut, use a new nut for assembly.
4. Remove the components from the shock absorber.
  - Keep the spring compressed in the commercial service tool if reusing it for assembly.

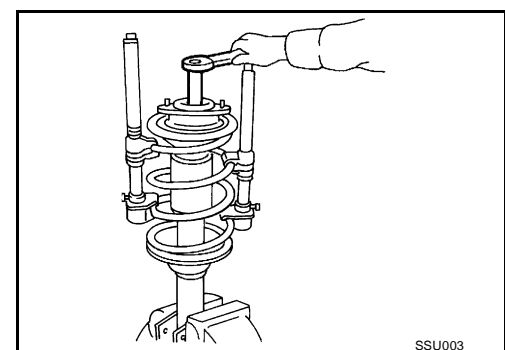

### INSPECTION AFTER DISASSEMBLY

#### Shock Absorber Assembly

- Check for smooth operation through a full stroke, both compression and extension.
- Check for oil leakage on welded or gland packing portions.
- Check piston rod for cracks, deformation or other damage and replace if necessary.

# COIL SPRING AND SHOCK ABSORBER

## Mounting Insulator and Rubber Parts

Check cemented rubber-to-metal portion for separation or cracks. Check rubber parts for deterioration and replace if necessary.

## Coil Spring

- Check for cracks, deformation or other damage and replace if necessary.
- Check the free spring height.

### Front spring free height

2WD : 345.4 mm (13.6 in)

4WD : 356 mm (14.0 in)

## ASSEMBLY

1. When installing coil spring on strut, it must be positioned as shown.

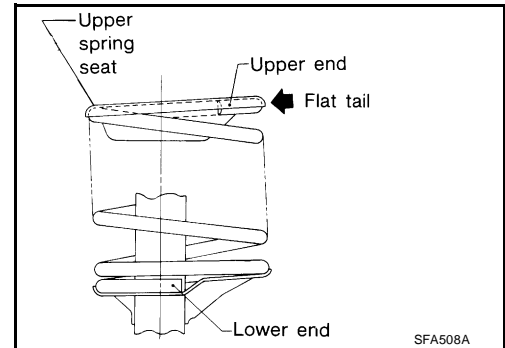

2. Install the shock absorber mounting insulator as shown in line with lower shock mount and step in lower seat.
  - The step in the strut assembly lower seat faces outside of vehicle.
3. Tighten the new piston rod lock nut to specification. Refer to [FSU-5, "Components"](#).
  - Use a new piston rod lock nut for assembly.

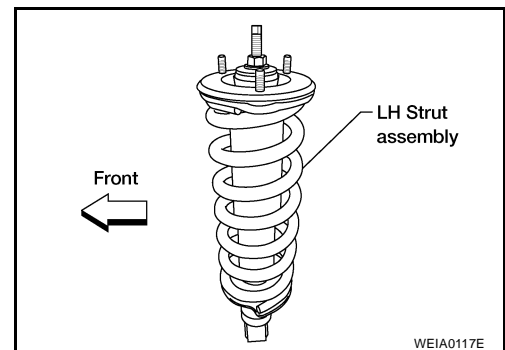

# STABILIZER BAR

## STABILIZER BAR

PF5:54611

### Removal and Installation

EES0019T

#### REMOVAL

1. Remove the front valance center.
2. Remove engine undercover using power tool.
3. Remove connecting rod nuts using power tool.
4. Loosen top bolts for stabilizer bar mounting brackets, then remove lower bolts from mounting brackets and remove stabilizer bar.
5. Remove bushings from stabilizer bar.

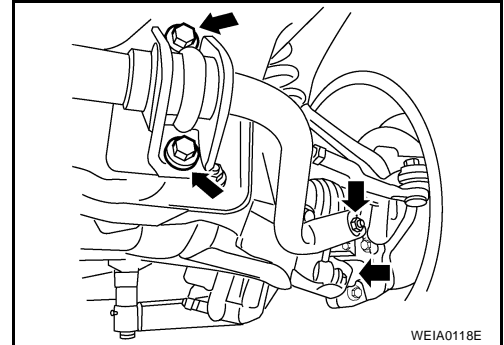

#### INSPECTION AFTER REMOVAL

- Check stabilizer bar for twist and deformation. Replace if necessary.
- Check rubber bushing for cracks, wear and deterioration. Replace if necessary.

#### INSTALLATION

Installation is in the reverse order of removal.

- Tighten all nuts and bolts to specification. Refer to [FSU-5, "Components"](#) .

# UPPER LINK

PFP:54524

EES0019U

## UPPER LINK

### Removal and Installation

#### REMOVAL

1. Remove the wheel and tire using power tool.
2. Support the lower link using a suitable jack.
3. For the LH side only, remove the bolt from the lower joint of the lower joint shaft, then reposition the lower joint shaft out of the way.

#### CAUTION:

- Do not damage the lower joint.

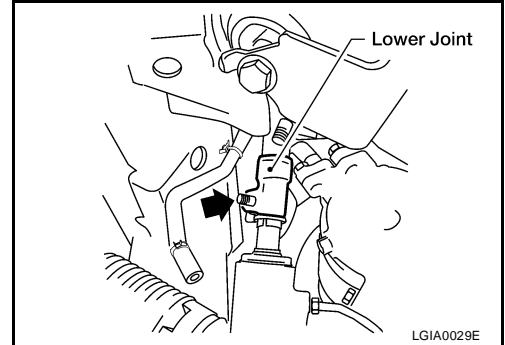

4. Remove cotter pin and nut from upper link ball joint.
5. Separate upper link ball joint stud from steering knuckle using Tool.

Tool number : ST29020001 (J-24319-01)

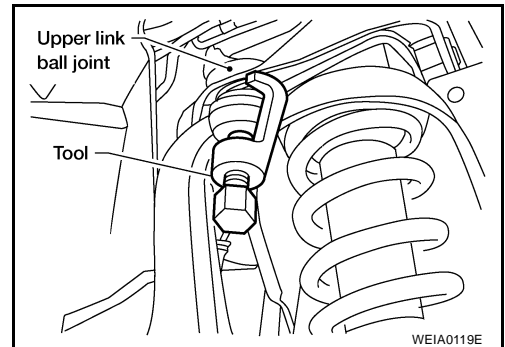

6. Remove upper link mounting bolts and nuts.

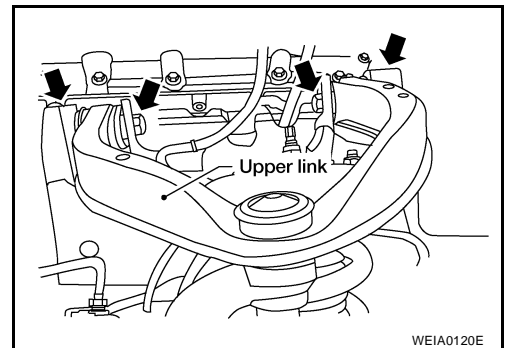

### INSPECTION AFTER REMOVAL

#### Upper Link

Check for deformation and cracks. Replace if necessary.

#### Upper Link Ball Joint

Check for distortion and damage. Replace if necessary.

### INSTALLATION

Installation is in the reverse order of removal.

- Tighten all nuts and bolts to specification. Refer to [FSU-5, "Components"](#) .

#### CAUTION:

**Always replace drive shaft lock nut and cotter pin.**

- When installing wheel and tire, refer to [WT-6, "Rotation"](#) .
- After installation, check that the front wheel alignment is within specification. Refer to [FSU-6, "Front Wheel Alignment"](#) .

A  
B  
C  
D  
FSU  
F  
G  
H  
I  
J  
K  
L  
M

# LOWER LINK

PFP:55020

EES0019V

## LOWER LINK

### Removal and Installation

#### REMOVAL

1. Remove the wheel and tire using power tool.
2. Remove lower shock absorber bolt.
3. Remove stabilizer bar connecting rod lower nut using power tool, then separate connecting rod from lower link. Refer to [FSU-12, "Removal and Installation"](#) .
4. On 4WD models, remove the drive shaft. Refer to [FFD-14, "Removal and Installation"](#) .
5. Remove pinch bolt from steering knuckle using power tool, then separate lower link ball joint from steering knuckle.

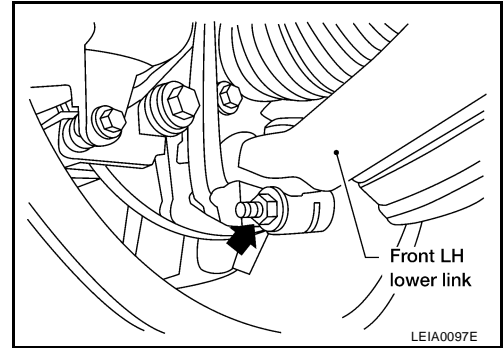

6. Remove lower link adjusting bolts and nuts, then the lower link.

#### NOTE:

Some vehicles may be equipped with straight (non-adjustable) lower link bolts and washers. In order to adjust camber and caster on these vehicles, first replace the lower link bolts and washers with adjustable (cam) bolts and washers.

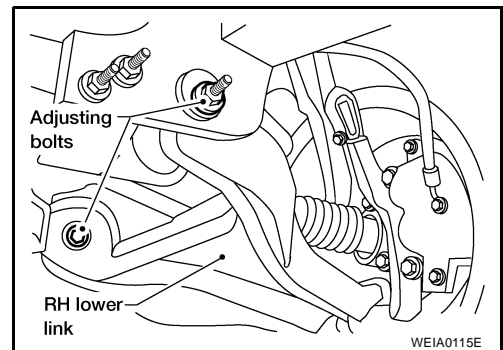

7. Remove the jounce bumper from the lower link.

### INSPECTION AFTER REMOVAL

#### Lower Link

Check for deformation and cracks. Replace if necessary.

#### Lower Link Bushing

Check for distortion and damage. Replace if necessary.

### INSTALLATION

Installation is in the reverse order of removal.

- Tighten all nuts and bolts to specification. Refer to [FSU-5, "Components"](#) .
- When installing wheel and tire, refer to [WT-6, "Rotation"](#) .
- After installation, check that the front wheel alignment is within specification. Refer to [FSU-6, "Front Wheel Alignment"](#) .

# UPPER BALL JOINT AND LOWER BALL JOINT

## UPPER BALL JOINT AND LOWER BALL JOINT

PPF:40110

### Removal and Installation

EES0022C

The ball joints are part of the upper and lower links. Refer to [FSU-13, "Removal and Installation"](#) (upper link), [FSU-14, "Removal and Installation"](#) (lower link).

### Inspection

EES0022D

- Check the ball joint for excessive play. Replace the upper or lower link assembly if any of the following exists:
  - Ball joint stud is worn.
  - Ball joint is hard to swing.
  - Ball joint play in axial directions or end play is excessive.

### SWINGING FORCE

#### NOTE:

Before checking the axial forces and end play, turn the lower ball joint at least 10 revolutions so that the ball joint is properly broken in.

1. Measure the ball joint swinging force using a suitable tool.
  - Measure at the cotter pin hole for upper ball joint as shown.
  - Measure at the groove for lower ball joint as shown.

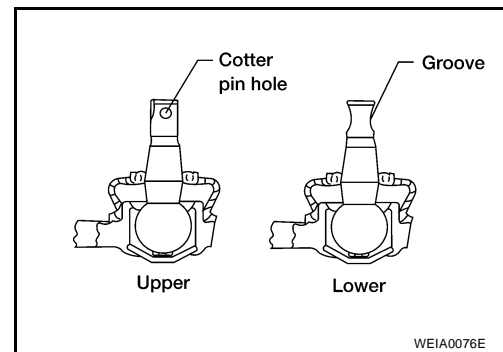

2. Verify the ball joint swinging force is within specification.

**Swinging force "A" (Measurement point at either cotter pin hole or groove of ball stud)**

**Upper : 8.1 - 79 N (0.83 - 8.1 kg-f, 1.82 - 17.8 lb-f) at hole**

**Lower : 11.4 - 145.5 N (1.16 - 14.84 kg-f, 2.56 - 32.71 lb-f) at groove**

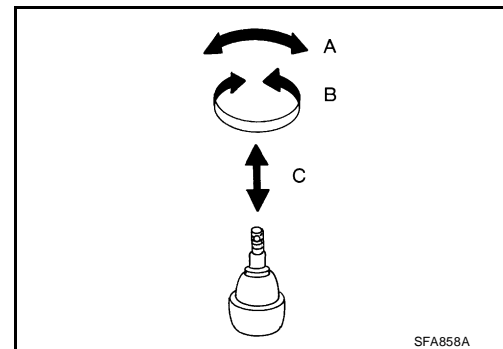

### TURNING FORCE

#### NOTE:

Before checking the axial forces and end play, turn the lower ball joint at least 10 revolutions so that the ball joint is properly broken in.

**Turning torque "B"**

**Upper : 0.5 - 4.9 N-m (0.05 - 0.49 kg-m, 5 - 43 in-lb)**

**Lower : 0.5 - 6.4 N-m (0.05 - 0.65 kg-m, 5 - 56 in-lb)**

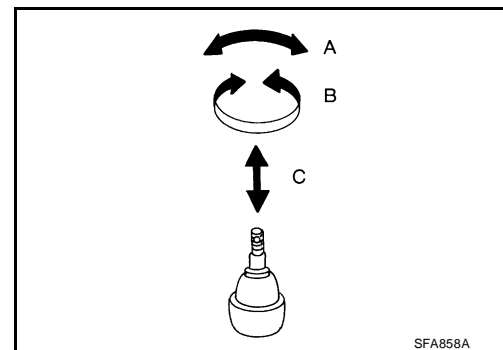

A  
B  
C  
D  
FSU  
F  
G  
H  
I  
J  
K  
L  
M

# UPPER BALL JOINT AND LOWER BALL JOINT

## VERTICAL END PLAY

Check dust cover for damage. Replace it and the cover clamp if necessary.

### NOTE:

Before checking the axial forces and end play, turn the lower ball joint at least 10 revolutions so that the ball joint is properly broken in.

**Vertical end play "C" : 0 mm (0 in)**

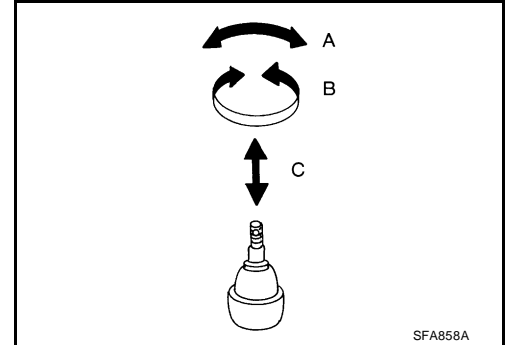



# KNUCKLE

## KNUCKLE

PFP:40014

### On-Vehicle Inspection and Service

EES0019Y

Make sure the mounting conditions (looseness, backlash) of each component and component status (wear, damage) are within specifications. Refer to [FSU-21, "Ball Joint"](#).

### Removal and Installation

EES0019Z

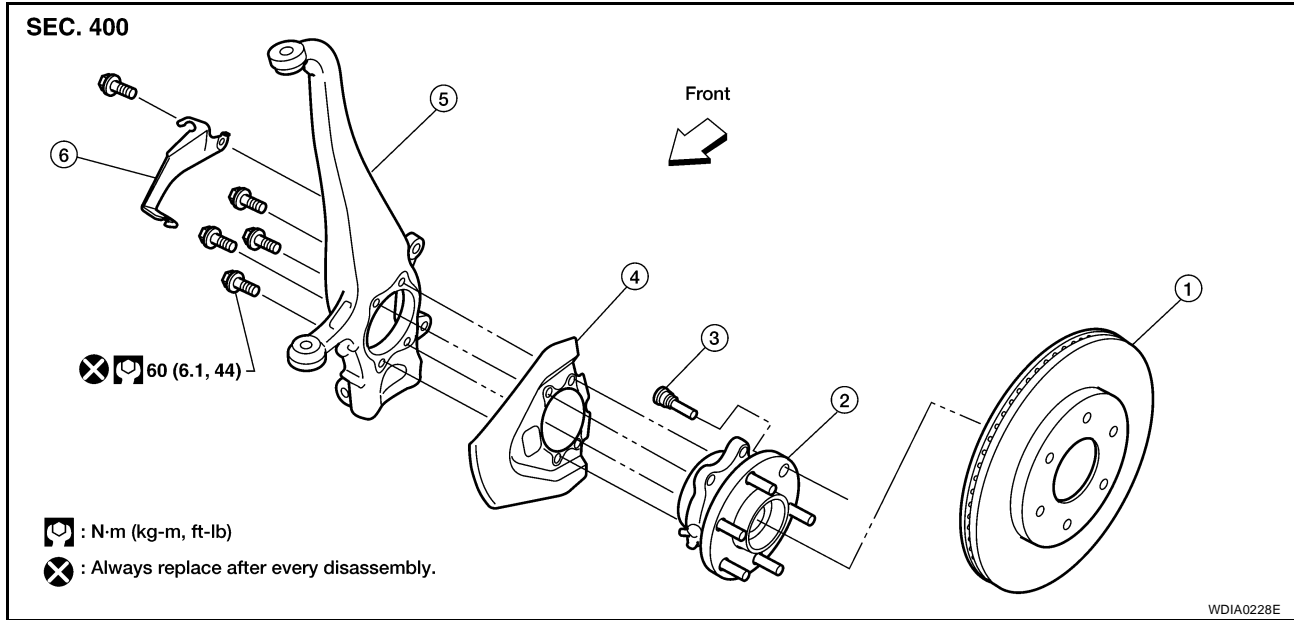

- |                 |                                   |                         |
|-----------------|-----------------------------------|-------------------------|
| 1. Disc rotor   | 2. Wheel hub and bearing assembly | 3. Wheel stud           |
| 4. Splash guard | 5. Steering knuckle               | 6. Wheel sensor bracket |

### REMOVAL

1. Remove wheel and tire from vehicle using power tool.
2. Without disassembling the hydraulic lines, remove brake caliper using power tool. Reposition it aside with wire. Refer to [BR-25, "Removal and Installation of Brake Caliper and Disc Rotor"](#).

#### NOTE:

Avoid depressing brake pedal while brake caliper is removed.

3. Put alignment marks on disc rotor and wheel hub and bearing assembly, then remove disc rotor.

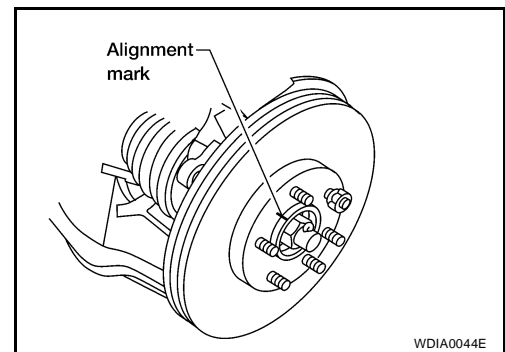

4. Disconnect wheel sensor and remove bracket from steering knuckle.

#### CAUTION:

**Do not pull on wheel sensor harness.**

5. On 4WD models, remove cotter pin, then remove lock nut from drive shaft using power tool. Refer to [FAX-7, "Removal and Installation"](#).
6. Remove steering outer socket cotter pin at steering knuckle, then loosen mounting nut using power tool. Refer to [PS-15, "Removal and Installation"](#).

# KNUCKLE

7. Disconnect steering outer socket from steering knuckle using Tool. Be careful not to damage ball joint boot.

**Tool number** : HT72520000 (J-25730-A)

**CAUTION:**

To prevent damage to threads and to prevent Tool from coming off suddenly, temporarily tighten nut.

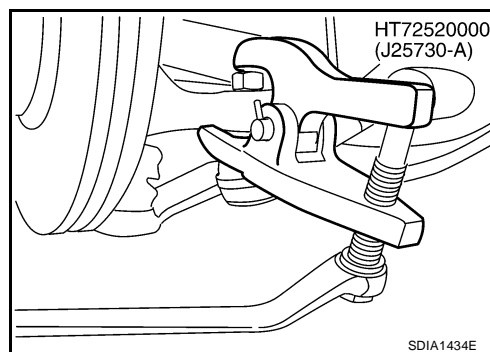

8. Remove wheel hub and bearing assembly bolts using power tool.  
9. Remove splash guard and wheel hub and bearing assembly from steering knuckle.

**CAUTION:**

Do not pull on wheel sensor harness.

10. Remove cotter pin and nut from upper link ball joint.  
11. Separate upper link ball joint from steering knuckle using Tool.

**Tool number** : ST29020001 (J-24319-01)

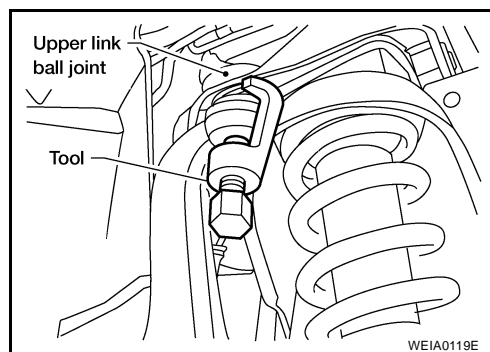

12. Remove pinch bolt from steering knuckle using power tool, then separate lower link ball joint from steering knuckle.

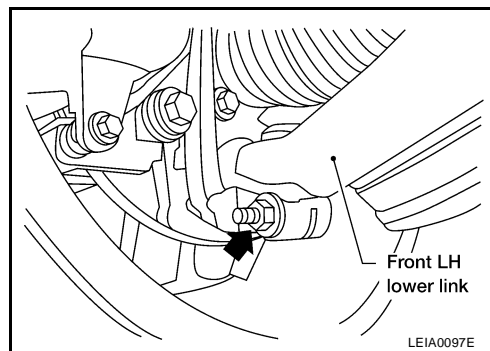

13. Remove steering knuckle from vehicle.

## INSPECTION AFTER REMOVAL

Check for deformity, cracks and damage on each part, replace if necessary.

- Perform ball joint inspection. Refer to [FSU-15, "Inspection"](#) .

# KNUCKLE

## INSTALLATION

Installation is in the reverse order of removal.

- For 4WD models, refer to [FAX-7, "Removal and Installation"](#) for drive shaft lock nut tightening torque.

**CAUTION:**

**Always replace drive shaft lock nut and cotter pin.**

- Refer to [PS-15, "Removal and Installation"](#) for outer socket nut tightening torque.
- Refer to [FSU-5, "Components"](#) for front suspension tightening torques.
- When installing disc rotor on wheel hub and bearing assembly, align the marks.

**NOTE:**

When not using the alignment mark, refer to [BR-36, "Front Disc Brake"](#) .

- When installing wheel and tire, refer to [WT-6, "Rotation"](#) .
- Perform wheel alignment. Refer to [FSU-6, "Front Wheel Alignment"](#) .

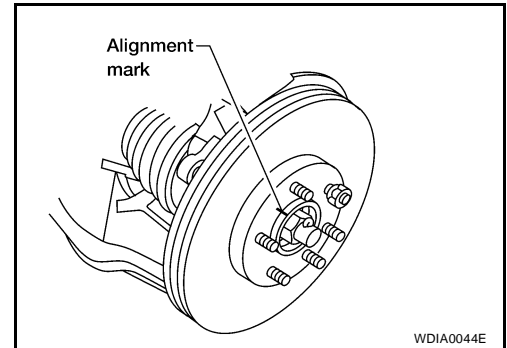

A  
B  
C  
D  
FSU  
F  
G  
H  
I  
J  
K  
L  
M

# SERVICE DATA AND SPECIFICATIONS (SDS)

## SERVICE DATA AND SPECIFICATIONS (SDS)

PFP:00030

### General Specifications (Front)

EES001A0

Suspension type	Independent double wishbone coil over shock
Shock absorber type	Double-acting hydraulic
Stabilizer	Standard equipment

### Wheel Alignment (Unladen\*1) \*6

EES001A1

Drive type		2WD	4WD
Camber Degree minute (decimal degree)	Minimum	-0° 30' (-0.50°)	-0° 15' (-0.25°)
	Nominal	0° 15' (0.25°)	0° 30' (0.50°)
	Maximum	1° 00' (1.00°)	1° 15' (1.25°)
	Cross camber	0° 45' (0.75°) or less	0° 45' (0.75°) or less
Caster Degree minute (decimal degree)	Minimum	2° 15' (2.25°)	2° 00' (2.00°)
	Nominal	3° 0' (3.00°)	2° 45' (2.75°)
	Maximum	3° 45' (3.75°)	3° 30' (3.50°)
	Cross caster	0° 45' (0.75°) or less	0° 45' (0.75°) or less
Kingpin inclination Degree minute (decimal degree)	Nominal	13° 0' (13.00°)	12° 45' (12.75°)

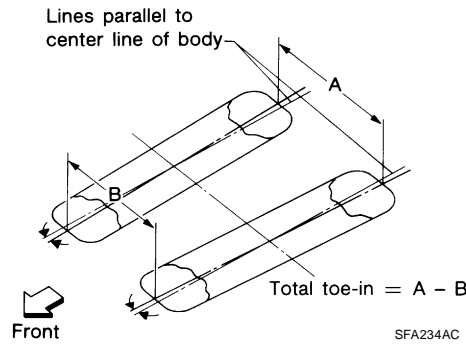

Total toe-in	Distance (A - B)	Minimum	2.1 mm (0.08 in)	2.1 mm (0.08 in)
		Nominal	3.1 mm (0.12 in)	3.1 mm (0.12 in)
		Maximum	4.1 mm (0.16 in)	4.1 mm (0.16 in)
	Angle (left wheel or right wheel) Degree minute (decimal degree)	Minimum	0° 5' (0.08°)	0° 5' (0.08°)
		Nominal	0° 7' (0.12°)	0° 7' (0.12°)
		Maximum	0° 9' (0.15°)	0° 9' (0.15°)
Wheel turning angle (full turn)	Inside Degree minute (Decimal degree)	33° 26' - 35° 26' *2 (33.43° - 35.43°)	33° 33' - 35° 33' *4 (33.60° - 35.60°)	
	Outside Degree minute (Decimal degree)	29° 22' - 31° 22' *3 (29.37° - 31.37°)	29° 38' - 31° 38' *5 (29.73° - 31.73°)	

\*1: Fuel, radiator coolant and engine oil full. Spare tire, jack, hand tools and mats in designated positions.

\*2: Target value 35° 26' (35.43°)

\*3: Target value 31° 22' (31.37°)

\*4: Target value 35° 33' (35.55°)

\*5: Target value 31° 38' (31.63°)

\*6: Some vehicles may be equipped with straight (non-adjustable) lower link bolts and washers. In order to adjust camber and caster on these vehicles, first replace the lower link bolts and washers with adjustable (cam) bolts and washers.

# SERVICE DATA AND SPECIFICATIONS (SDS)

## Ball Joint

EES001A2

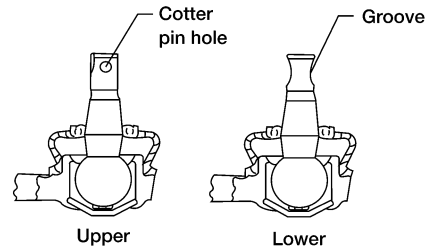
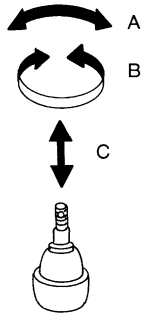

SFA858A

WEIA0076E

Swinging force "A" (Measurement point at either cotter pin hole or groove of ball stud.)	Upper	8.1 - 79 N (0.83 - 8.1 kg-f, 1.82 - 17.8 lb-f) at hole
	Lower	11.4 - 145.5 N (1.16 - 14.84 kg-f, 2.56 - 32.71 lb-f) at groove
Turning torque "B"	Upper	0.5 - 4.9 N·m (0.05 - 0.49 kg-m, 5 - 43 in-lb)
	Lower	0.5 - 6.4 N·m (0.05 - 0.65 kg-m, 5 - 56 in-lb)
Vertical end play "C"		0 mm (0 in)

## Wheelarch Height (Unladen\*<sup>1</sup>)

EES001PZ

Unit: mm (in)

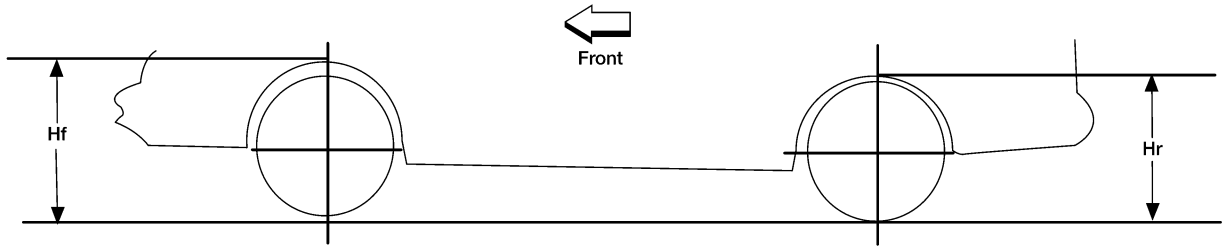

LEIA0085E

Drive type	2WD				Part time 4WD			Full time 4WD
	XE	SE		LE	XE	SE		LE
Applied model	XE	SE		LE	XE	SE		LE
Tire size	245/75R16	265/70R16	265/75R16	265/65R17	245/75R16	265/70R16	265/75R16	265/65R17
Front wheelarch height (Hf)	866 (34.09)	867 (34.13)	879 (34.61)	868 (34.17)	874 (34.41)	876 (34.49)	888 (34.96)	878 (34.57)
Rear wheelarch height (Hr)	875 (34.45)	876 (34.49)	888 (34.96)	877 (34.53)	885 (34.84)	886 (34.88)	898 (35.35)	887 (34.92)

\*1: Fuel, radiator coolant and engine oil full. Spare tire, jack, hand tools and mats in designated positions.

# SERVICE DATA AND SPECIFICATIONS (SDS)

---