

# ENGINE LUBRICATION & COOLING SYSTEMS

GI

MA

EM

LC

EC

FE

CL

MT

AT

TF

PD

AX

SU

BR

ST

RS

BT

HA

SC

EL

IDX

## SECTION LC

### CONTENTS

<b>ENGINE LUBRICATION SYSTEM</b> .....	2	CHECKING RADIATOR.....	12
Precautions.....	2	CHECKING RADIATOR CAP.....	13
LIQUID GASKET APPLICATION PROCEDURE.....	2	CHECKING COOLING SYSTEM FOR LEAKS.....	13
Preparation.....	2	Water Pump.....	14
SPECIAL SERVICE TOOLS.....	2	REMOVAL AND INSTALLATION.....	14
COMMERCIAL SERVICE TOOL.....	3	REMOVAL.....	15
Lubrication Circuit.....	3	INSPECTION.....	16
Oil Pressure Check.....	5	INSTALLATION.....	17
Oil Pump.....	6	Thermostat.....	19
REMOVAL AND INSTALLATION.....	6	REMOVAL AND INSTALLATION.....	19
DISASSEMBLY AND ASSEMBLY.....	6	INSPECTION.....	19
OIL PUMP INSPECTION.....	7	Water Control Valve.....	20
REGULATOR VALVE INSPECTION.....	7	REMOVAL AND INSTALLATION.....	20
OIL FILTER.....	8	INSPECTION.....	21
Oil Cooler.....	8	Radiator.....	22
REMOVAL AND INSTALLATION.....	8	REMOVAL AND INSTALLATION.....	22
INSPECTION.....	9	Cooling Fan (Crankshaft driven).....	23
Service Data and Specifications (SDS).....	9	REMOVAL AND INSTALLATION.....	23
OIL PRESSURE.....	9	INSPECTION.....	23
REGULATOR VALVE.....	9	Refilling Engine Coolant.....	23
OIL PUMP.....	9	Radiator (Aluminum type).....	24
<b>ENGINE COOLING SYSTEM</b> .....	10	PREPARATION.....	24
Precautions.....	10	DISASSEMBLY.....	24
LIQUID GASKET APPLICATION PROCEDURE.....	10	ASSEMBLY.....	25
Preparation.....	10	INSPECTION.....	26
SPECIAL SERVICE TOOLS.....	10	Overheating Cause Analysis.....	27
COMMERCIAL SERVICE TOOL.....	11	Service Data and Specifications (SDS).....	28
Cooling Circuit.....	11	THERMOSTAT.....	28
System Check.....	12	WATER CONTROL VALVE.....	28
CHECKING COOLING SYSTEM HOSES.....	12	RADIATOR.....	28

# ENGINE LUBRICATION SYSTEM

## Precautions

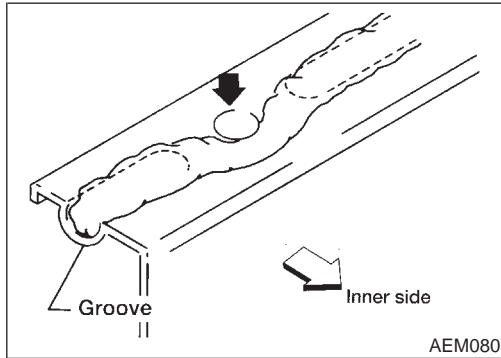
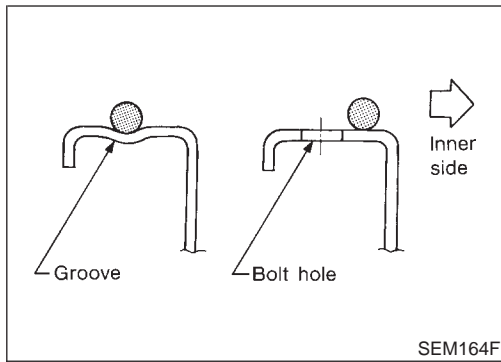

## Precautions

### LIQUID GASKET APPLICATION PROCEDURE

NALC0001

1. Use a scraper to remove all traces of old liquid gasket from mating surfaces and grooves. Also, completely clean any oil from these areas.
2. Apply a continuous bead of liquid gasket to mating surfaces. **(Use Genuine RTV silicone sealant or equivalent. Refer to GI-53.)**
  - For oil pan, be sure liquid gasket diameter is 4.0 to 5.0 mm (0.157 to 0.197 in).
  - For areas except oil pan, be sure liquid gasket diameter is 2.0 to 3.0 mm (0.079 to 0.118 in).
3. Apply liquid gasket around the inner side of bolt holes (unless otherwise specified).
4. Assembly should be done within 5 minutes after coating.
5. Wait at least 30 minutes before refilling engine oil and engine coolant.

## Preparation

### SPECIAL SERVICE TOOLS

NALC0002

The actual shapes of Kent-Moore tools may differ from those of special service tools illustrated here.

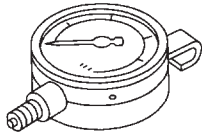
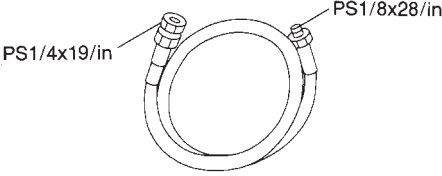
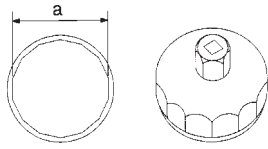
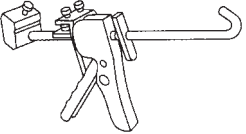
Tool number (Kent-Moore No.) Tool name	Description
ST25051001 (J25695-1) Oil pressure gauge	 <p>Measuring oil pressure <b>Maximum measuring range:</b> 2,452 kPa (24.52 bar, 25 kg/cm<sup>2</sup>, 356 psi)</p> <p>NT050</p>
ST25052000 (J25695-2) Hose	 <p>Adapting oil pressure gauge to upper oil pan</p> <p>NT559</p>
KV10115801 (J38956) Oil filter wrench	 <p>Removing oil filter <b>a: 64.3 mm (2.531 in)</b></p> <p>NT375</p>
WS39930000 ( — ) Tube pressure	 <p>Pressing the tube of liquid gasket</p> <p>NT052</p>

# ENGINE LUBRICATION SYSTEM

Preparation (Cont'd)

## COMMERCIAL SERVICE TOOL

NALC0040

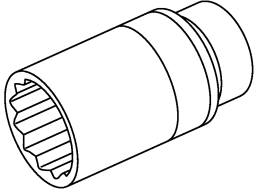
Tool name	Description
Deep socket	<p>Removing and installing oil pressure switch Deep socket 26 mm, 3/8 drive</p>  <p>NT818</p>

## Lubrication Circuit

NALC0003

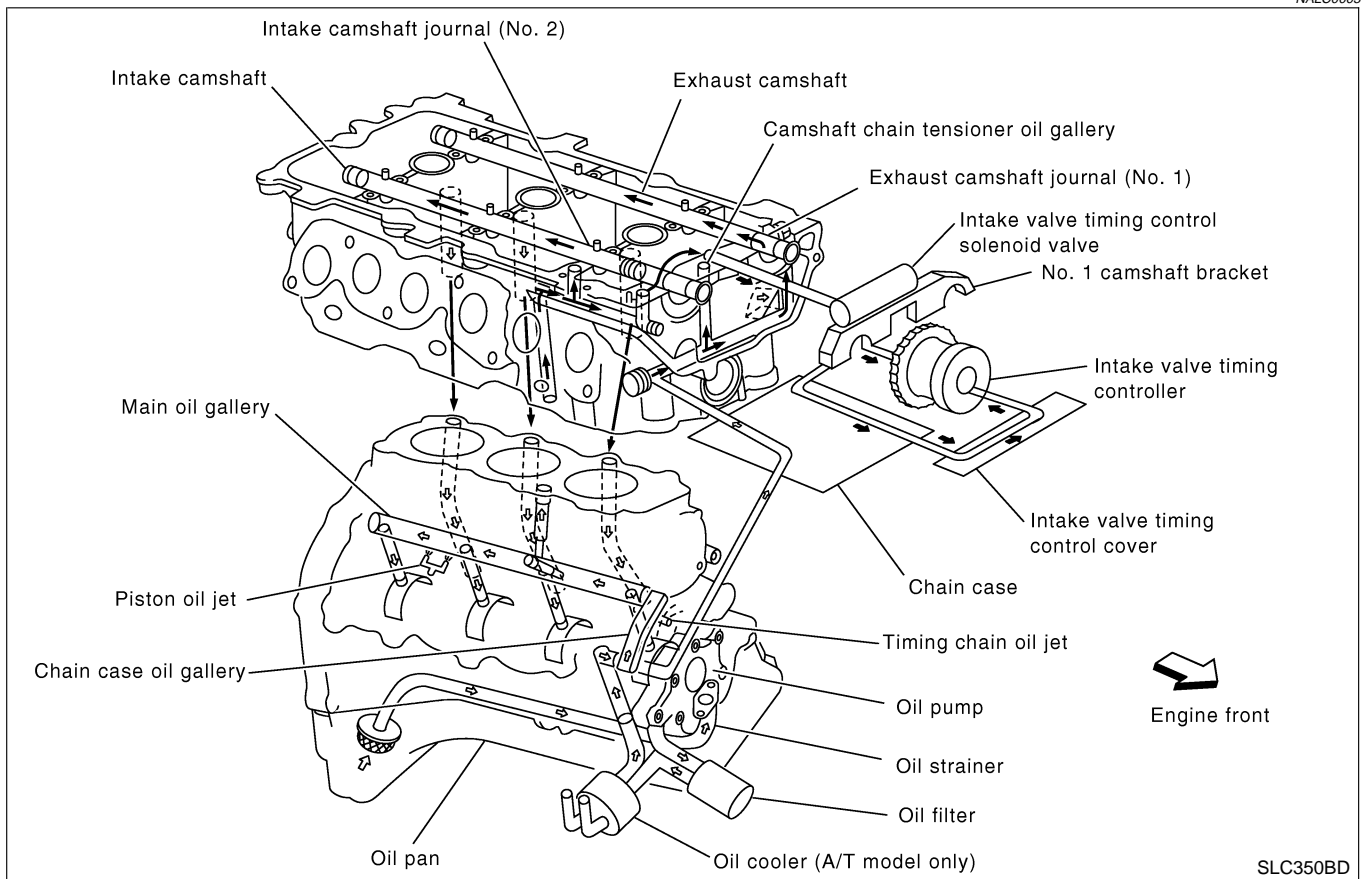

GI  
MA  
EM  
LC  
EC  
FE  
CL  
MT  
AT  
TF  
PD  
AX  
SU  
BR  
ST  
RS  
BT  
HA  
SC  
EL  
IDX

# ENGINE LUBRICATION SYSTEM

Lubrication Circuit (Cont'd)

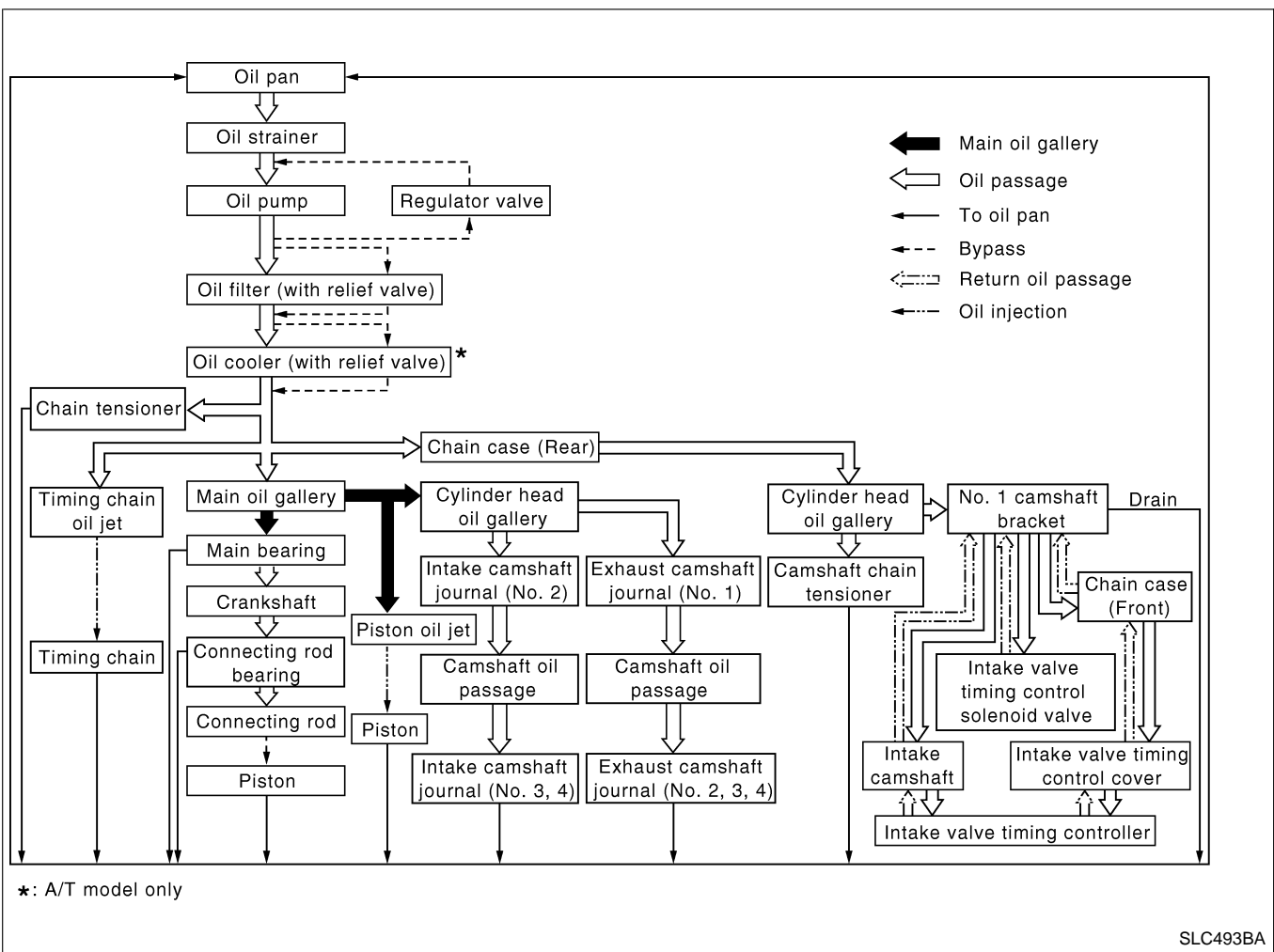

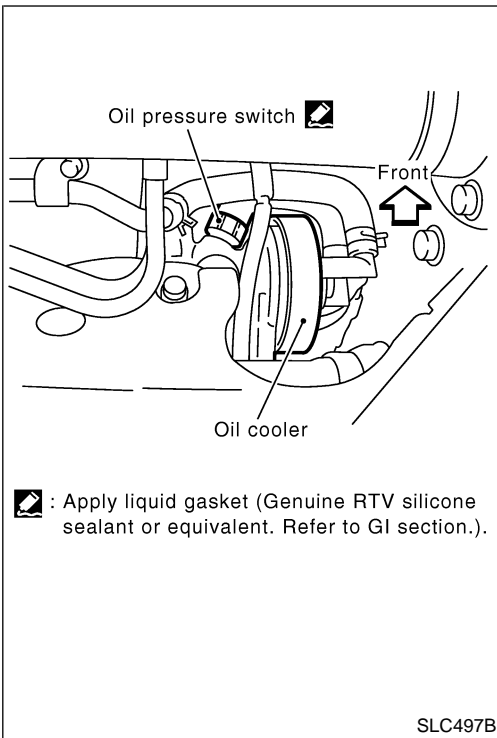

## Oil Pressure Check

### WARNING:

- Be careful not to burn yourself, as the engine and engine oil may be hot.
  - Oil pressure check should be done in “Neutral position” (M/T) or “Parking position” (A/T).
1. Check engine oil level.
  2. Disconnect oil pressure switch harness connector.
  3. Remove oil pressure switch using a deep socket. (Commercial service tool)
  4. Install oil pressure gauge and hose.
  5. Start engine and warm it up to normal operating temperature.
  6. Check oil pressure with engine running under no-load.

Engine speed rpm	Approximate discharge pressure kPa (kg/cm <sup>2</sup> , psi)
Idle speed 2,000	More than 100 (1.0, 15) 290 (3.0, 42)

**If difference is extreme, check oil passage and oil pump for oil leaks.**

7. After the inspections, install the oil pressure switch as follows.
  - a. Remove the old sealant adhering to switch and engine.
  - b. Apply Genuine RTV silicone sealant or equivalent to the thread and tighten. Refer to GI-53.

**13 - 17 N·m (1.25 - 1.75 kg-m, 9 - 12 ft-lb)**

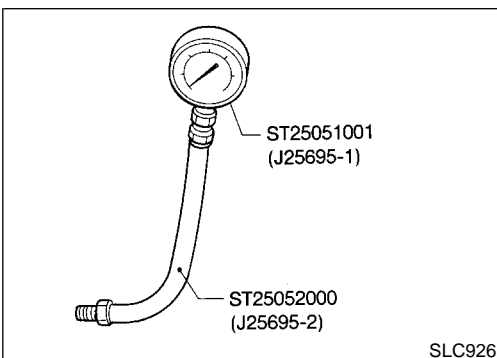
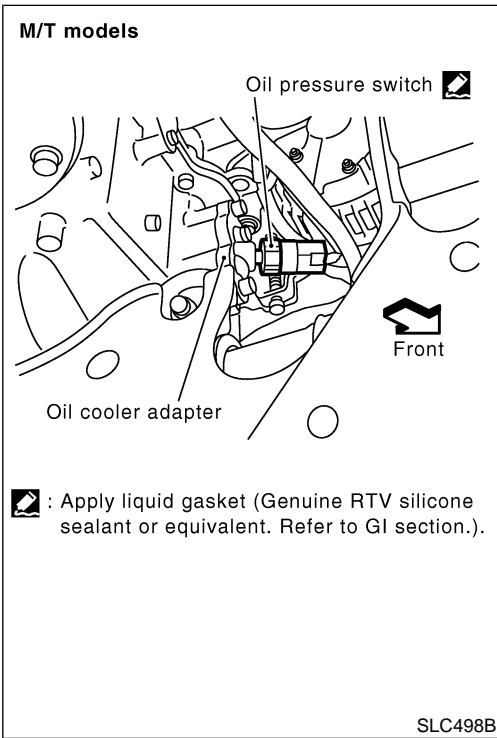

# ENGINE LUBRICATION SYSTEM

## Oil Pump

### REMOVAL AND INSTALLATION

=NALC0005

1. Remove timing chain. Refer to EM-27, "Removal".
2. Remove oil pump assembly.
  - Inspect the oil pump after removing it.
3. Reinstall any parts removed in reverse order of removal.

### DISASSEMBLY AND ASSEMBLY

NALC0006

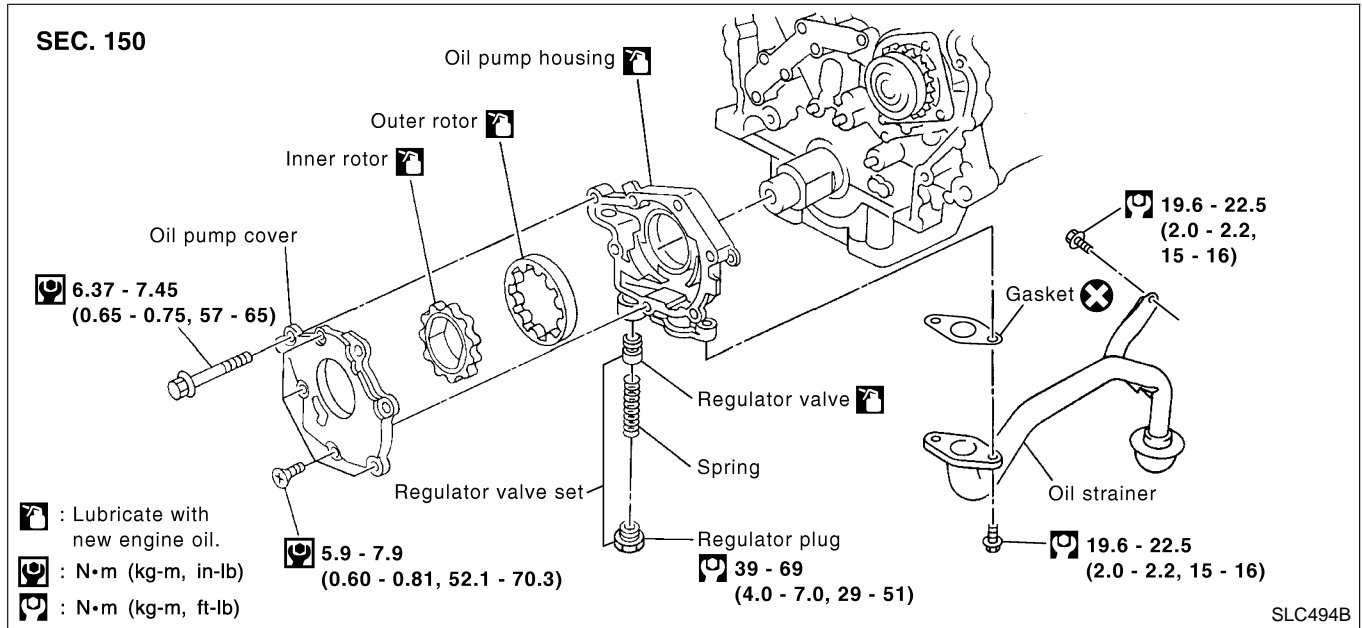

- When installing oil pump, apply engine oil to rotors.

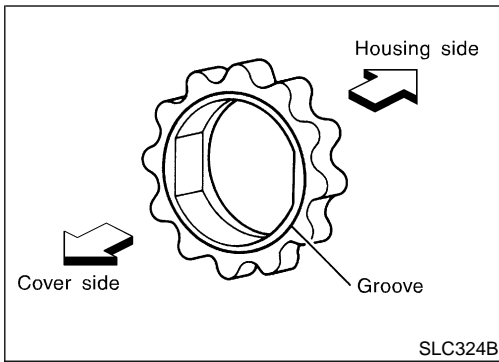

## OIL PUMP INSPECTION

NALC0007

- Install oil pump with the groove of the inner rotor facing the oil pump cover.

Using a feeler gauge, straightedge and micrometers, check the following clearances:

Unit: mm (in)

Body to outer rotor radial clearance 1	0.114 - 0.260 (0.0045 - 0.0102)
Inner rotor to outer gear tip clearance 2	Below 0.180 (0.0071)
Body to inner rotor axial clearance 3	0.030 - 0.070 (0.0012 - 0.0028)
Body to outer rotor axial clearance 4	0.050 - 0.110 (0.0020 - 0.0043)
Inner rotor to brazed portion of housing clearance 5	0.045 - 0.091 (0.0018 - 0.0036)

- If measured/calculated values are out of the standard, replace oil pump assembly.

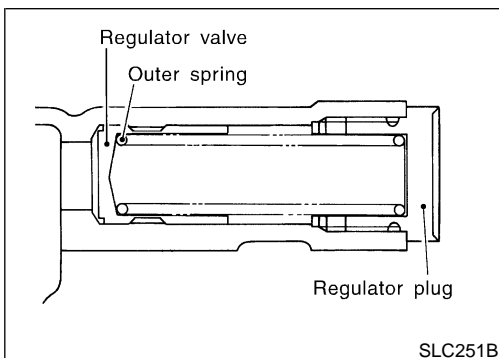
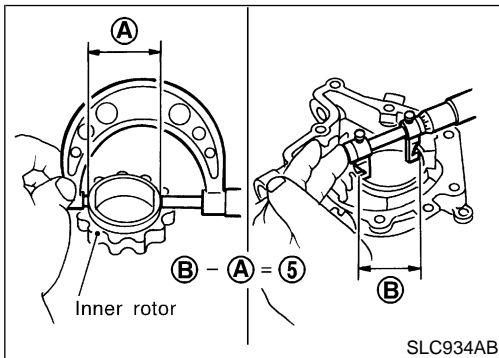
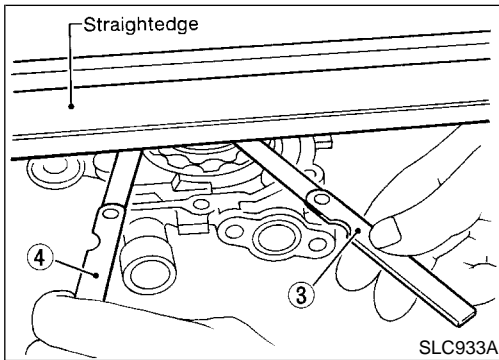
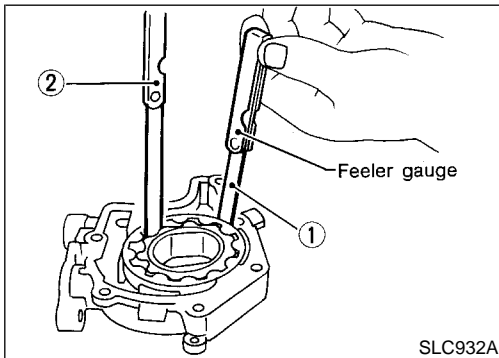

## REGULATOR VALVE INSPECTION

NALC0008

1. Visually inspect components for wear and damage.
2. Check oil pressure regulator valve sliding surface and valve spring.
3. Coat regulator valve with engine oil. Check that it falls smoothly into the valve hole by its own weight.

If damaged, replace oil pump assembly.

GI  
MA  
EM  
LC  
EC  
FE  
CL  
MT  
AT  
TF  
PD  
AX  
SU  
BR  
ST  
RS  
BT  
HA  
SC  
EL  
IDX

# ENGINE LUBRICATION SYSTEM

## Oil Pump (Cont'd)

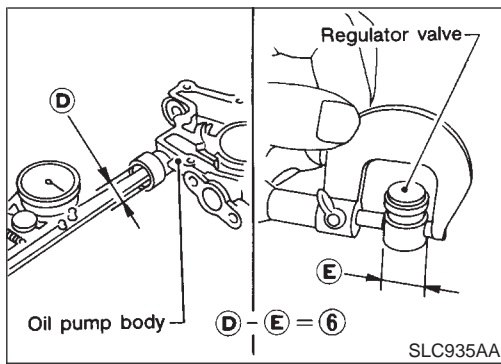

4. Check regulator valve to oil pump body clearance.

### Clearance:

**6 : 0.040 - 0.097 mm (0.0016 - 0.0038 in)**

If it exceeds the limit, replace oil pump assembly.

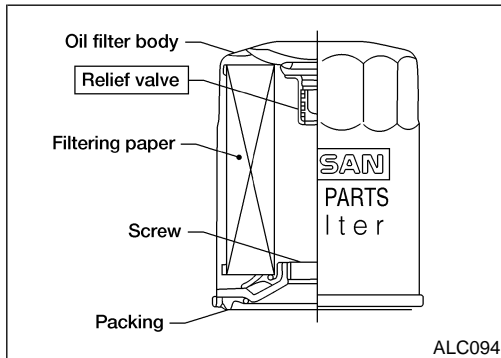

## OIL FILTER

The oil filter is a small, full-flow cartridge type and is provided with a relief valve. NALC0009

- Use Tool for removing oil filter.

## Oil Cooler

### REMOVAL AND INSTALLATION

NALC0036

**SEC. 150•213**  
**A/T models**

Gasket

Relief valve

Oil pressure switch

Oil cooler bracket

O-ring

Oil cooler

15.7 - 20.6  
(1.6 - 2.1, 12 - 15)

13 - 17  
(1.25 - 1.75, 9 - 12)

**M/T models**

Gasket

Oil pressure switch

Oil cooler adapter

16 - 20  
(1.6 - 2.1, 12 - 15)

13 - 17  
(1.25 - 1.75, 9 - 12)

☒ : Apply liquid gasket (Genuine RTV silicone sealant or equivalent. Refer to GI section.).

Ⓜ : N•m (kg-m, ft-lb)

SLC353BC

1. Disconnect water hoses from oil cooler, pinching water hose to prevent engine coolant spill.

- Do not spill engine coolant on the drive belt.

2. Remove oil cooler.

## LC-8



- Inspect the oil cooler after removing it.

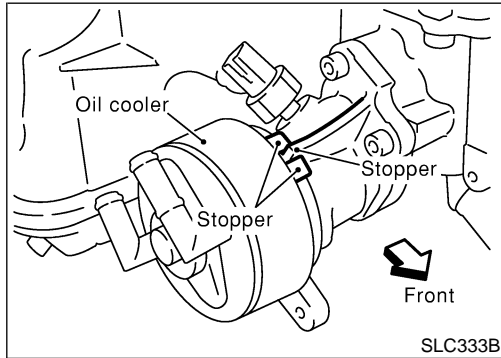

3. Installation is in reverse order of removal.
  - **When installing the oil cooler, align the oil cooler stopper with the stopper of the oil cooler bracket.**

## INSPECTION

### Oil Cooler

1. Check oil cooler for cracks.
2. Check oil cooler for clogging by blowing through engine coolant inlet.  
If necessary, replace oil cooler assembly.

NALC0037

NALC0037S01

### Oil Pressure Relief Valve

Inspect oil pressure relief valve for movement, cracks and breaks by pushing the ball. If replacement is necessary, remove valve by prying it out with a suitable tool. Install a new valve in place by tapping it.

NALC0037S02

## Service Data and Specifications (SDS)

### OIL PRESSURE

NALC0010

Engine speed rpm	Approximate discharge pressure kPa (kg/cm <sup>2</sup> , psi)
Idle speed 2,000	More than 100 (1.0, 15) 290 (3.0, 42)

### REGULATOR VALVE

NALC0011

Unit: mm (in)

Regulator valve to oil pump cover clearance	0.040 - 0.097 (0.0016 - 0.0038)
---	---------------------------------

### OIL PUMP

NALC0012

Unit: mm (in)

Body to outer rotor radial clearance	0.114 - 0.260 (0.0045 - 0.0102)
Inner rotor to outer rotor tip clearance	Below 0.180 (0.0071)
Body to inner rotor axial clearance	0.030 - 0.070 (0.0012 - 0.0028)
Body to outer rotor axial clearance	0.050 - 0.110 (0.0020 - 0.0043)
Inner rotor to brazed portion of housing clearance	0.045 - 0.091 (0.0018 - 0.0036)

# ENGINE COOLING SYSTEM

## Precautions

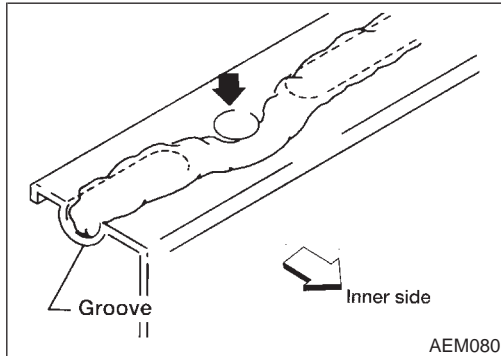
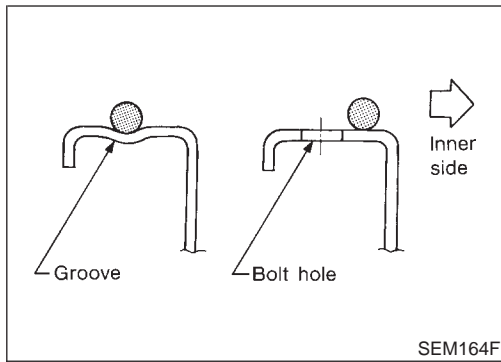

## Precautions

### LIQUID GASKET APPLICATION PROCEDURE

NALC0013



1. Use a scraper to remove all traces of old liquid gasket from mating surfaces and grooves. Also, completely clean any oil from these areas.
2. Apply a continuous bead of liquid gasket to mating surfaces. **(Use Genuine RTV silicone sealant or equivalent. Refer to GI-53.)**
3. Apply liquid gasket around the inner side of bolt holes (unless otherwise specified).
4. Assembly should be done within 5 minutes after coating.
5. Wait at least 30 minutes before refilling engine oil and engine coolant.

## Preparation

### SPECIAL SERVICE TOOLS

NALC0014

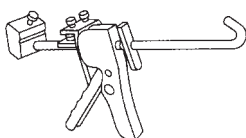
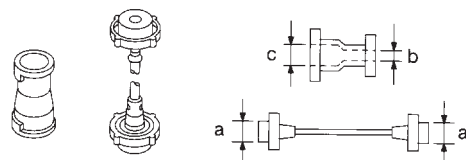
The actual shapes of Kent-Moore tools may differ from those of special service tools illustrated here.

Tool number (Kent-Moore No.) Tool name	Description
WS39930000 ( — ) Tube pressure	 Pressing the tube of liquid gasket NT052
EG17650301 (J33984-A) Radiator cap tester adapter	 Adapting radiator cap tester to radiator cap and radiator filler neck <b>a: 28 (1.10) dia.</b> <b>b: 31.4 (1.236) dia.</b> <b>c: 41.3 (1.626) dia.</b> Unit: mm (in) NT564
KV99103510 ( — ) Radiator plate pliers A	 Installing radiator upper and lower tanks NT224
KV99103520 ( — ) Radiator plate pliers B	 Removing radiator upper and lower tanks NT225

# ENGINE COOLING SYSTEM

Preparation (Cont'd)

## COMMERCIAL SERVICE TOOL

NALC0041

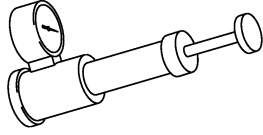
Tool name	Description
Radiator cap tester	<p>Checking radiator and radiator cap</p>  <p>PBIC1982E</p>

## Cooling Circuit

NALC0015

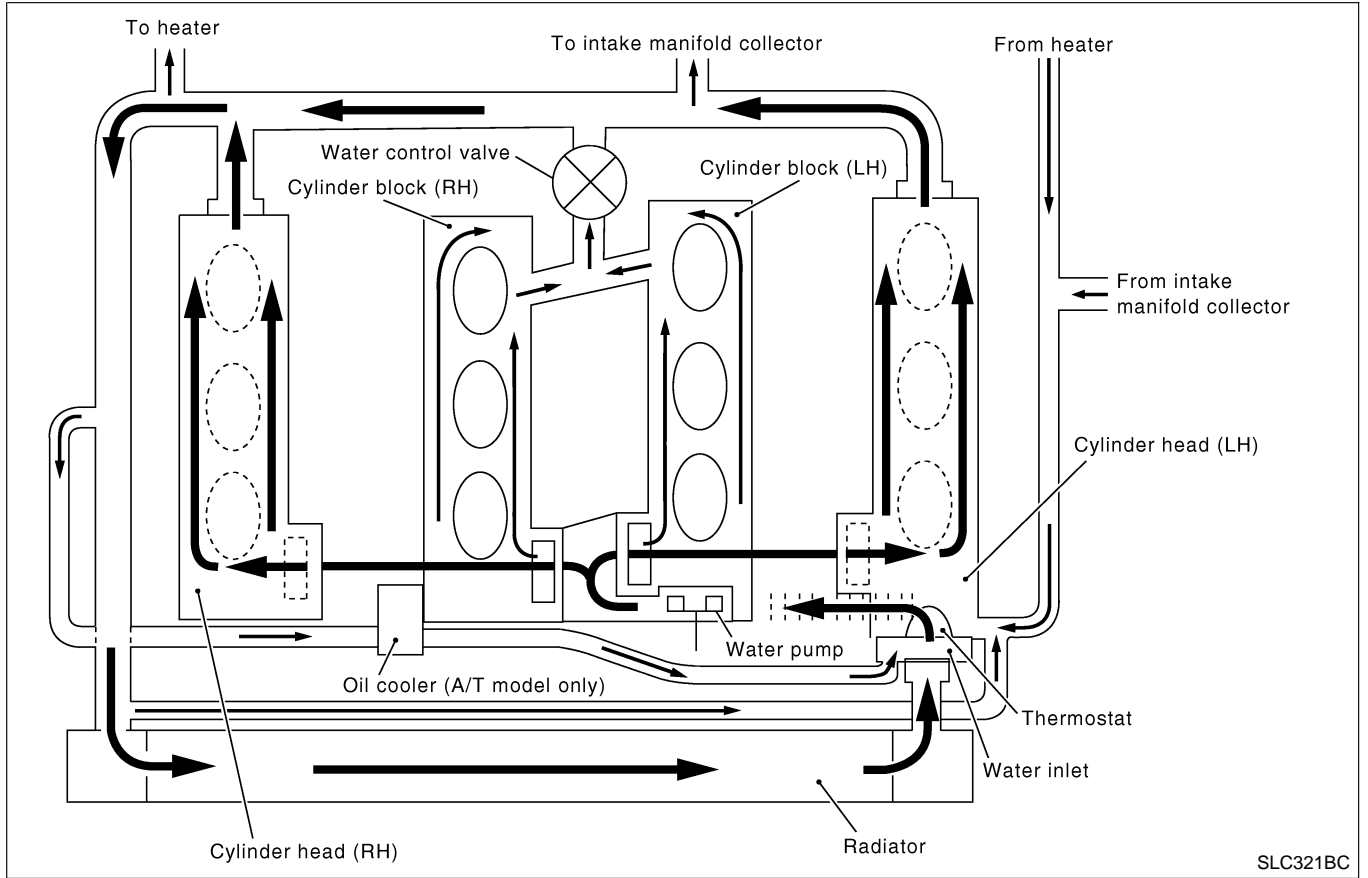

SLC321BC

# ENGINE COOLING SYSTEM

Cooling Circuit (Cont'd)

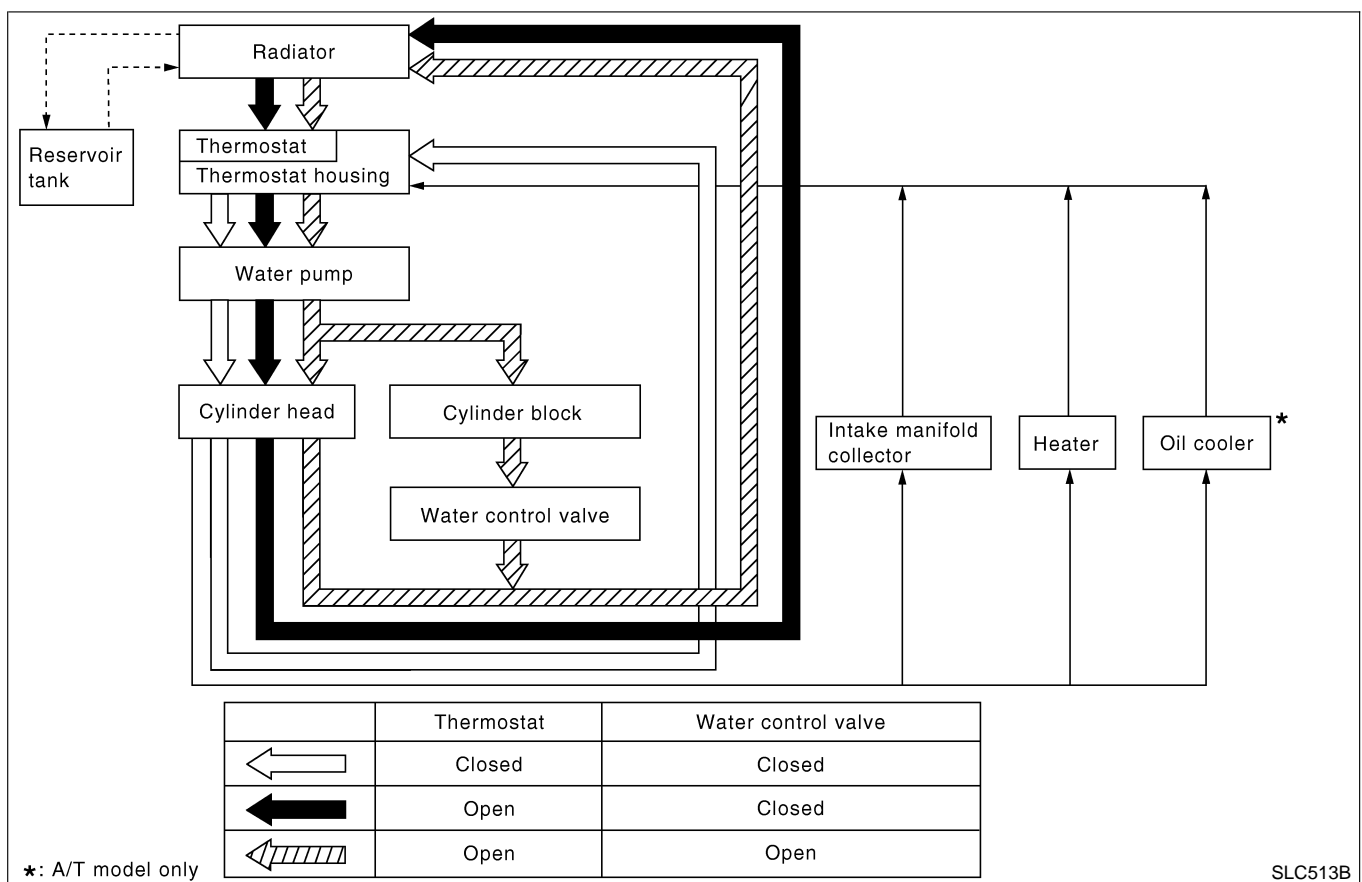

## System Check

NALC0016

### WARNING:

Never remove the radiator cap when the engine is hot; serious burns could be caused by high pressure fluid escaping from the radiator.

Wrap a thick cloth around the cap and carefully remove it by turning it a quarter turn to allow built-up pressure to escape and then turn the cap all the way off.

### CHECKING COOLING SYSTEM HOSES

NALC0016S01

Check hoses for improper attachment, leaks, cracks, damage, loose connections, chafing and deterioration.

### CHECKING RADIATOR

NALC0016S02

Check radiator for mud or clogging. If necessary, clean radiator as follows.

- Be careful not to bend or damage the radiator fins.
  - When radiator is cleaned without removal, remove all surrounding parts such as cooling fan, radiator shroud and horns. Then tape the harness and electrical connectors to prevent water from entering.
1. Apply water by hose to the back side of the radiator core vertically downward.

2. Apply water again to all radiator core surfaces once per minute.
3. Stop washing if any stains no longer flow out from the radiator.
4. Blow air into the back side of radiator core vertically downward.
  - Use compressed air lower than 490 kPa (5 kg/cm<sup>2</sup>, 71 psi) and keep distance more than 30 cm (11.8 in).
5. Blow air again into all the radiator core surfaces once per minute until no water sprays out.

GI  
MA  
EM  
LC

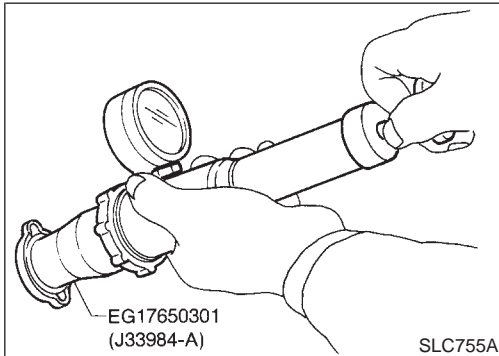

## CHECKING RADIATOR CAP

To check radiator cap, apply pressure to cap with a tester. NALC0016S03

### Radiator cap relief pressure:

#### Standard

78 - 98 kPa

(0.8 - 1.0 kg/cm<sup>2</sup>, 11 - 14 psi)

#### Limit

59 kPa (0.6 kg/cm<sup>2</sup>, 9 psi)

- When connecting radiator cap to radiator cap tester (commercial service tool) with Tool, apply engine coolant to the cap seal surface.

EC  
FE  
CL  
MT  
AT

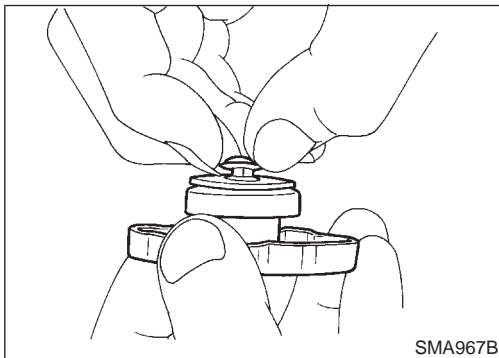

Pull the negative pressure valve to open it. Check that it closes completely when released.

TF  
PD  
AX  
SU  
BR

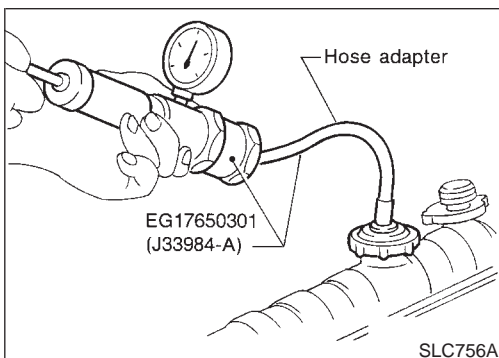

## CHECKING COOLING SYSTEM FOR LEAKS

To check for leakage, apply pressure to the cooling system with a tester. NALC0016S04

### Testing pressure:

157 kPa (1.6 kg/cm<sup>2</sup>, 23 psi)

### CAUTION:

Higher than the specified pressure may cause radiator damage.

### NOTE:

When engine coolant decreases, replenish radiator with engine coolant.

ST  
RS  
BT  
HA  
SC  
EL  
IDX

# ENGINE COOLING SYSTEM

## Water Pump REMOVAL AND INSTALLATION

NALC0017

### CAUTION:

- When removing water pump assembly, be careful not to get engine coolant on drive belt.
- Water pump cannot be disassembled and should be replaced as a unit.
- After installing water pump, connect hose and clamp securely, then check for leaks using radiator cap tester (commercial service tool).

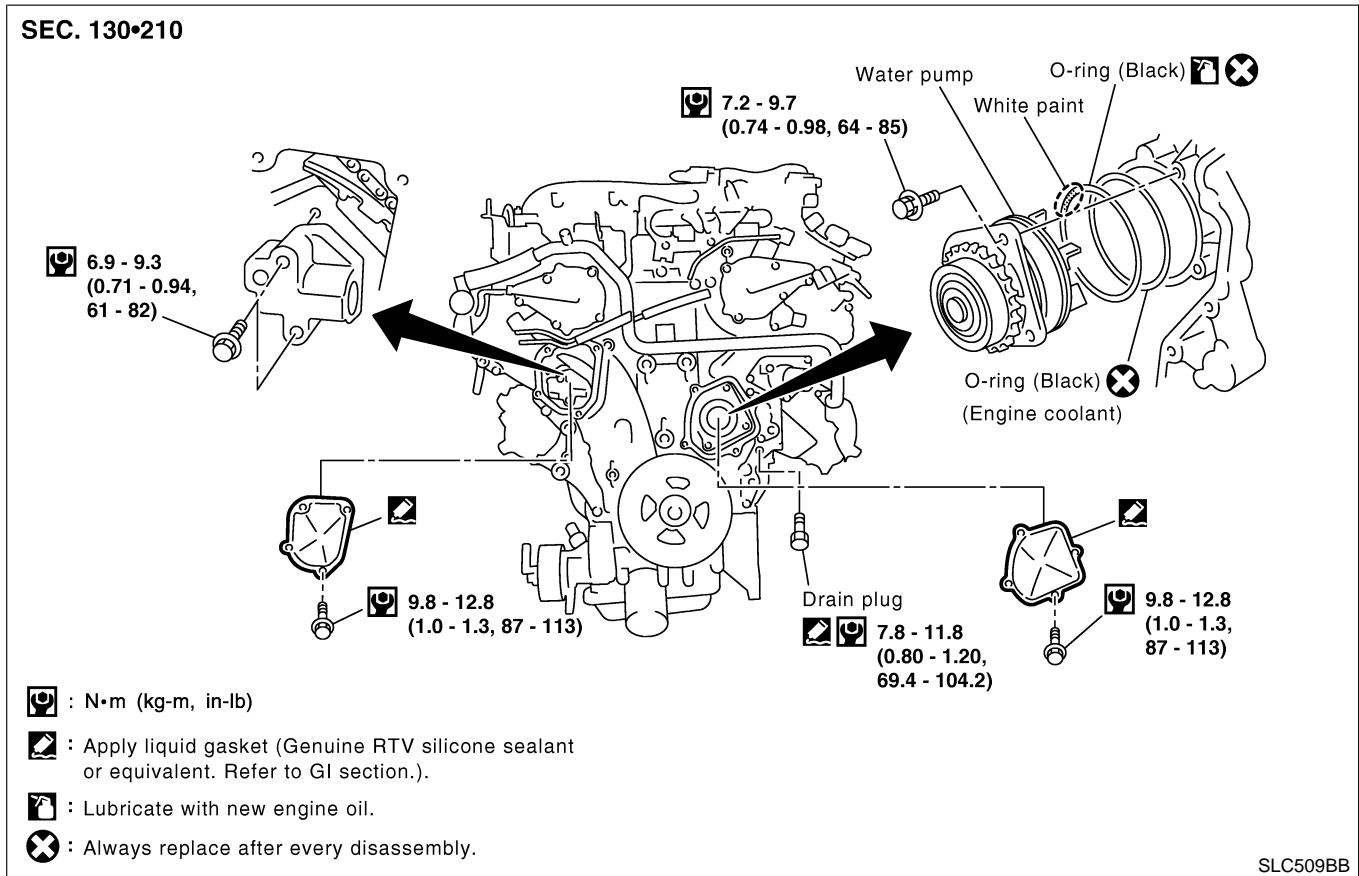

=NALC0018

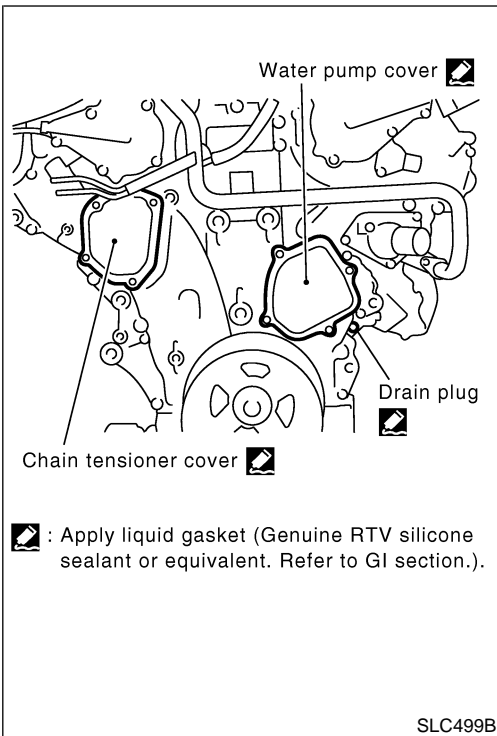

## REMOVAL

1. Remove undercover.
2. Remove suspension member stay.
3. Drain coolant from radiator.
4. Remove radiator shrouds.
5. Remove drive belts.
6. Remove cooling fan.
7. Remove water drain plug on water pump side of cylinder block.
8. Remove chain tensioner cover and water pump cover.

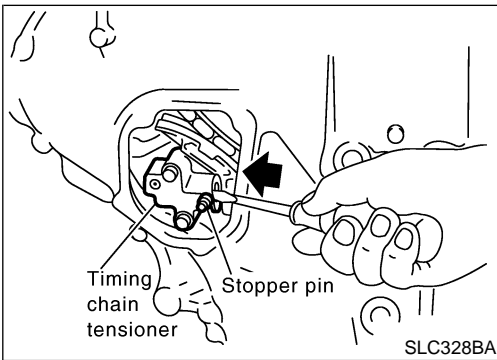

9. Pushing timing chain tensioner sleeve, apply a stopper pin so it does not return. Then remove timing chain tensioner.

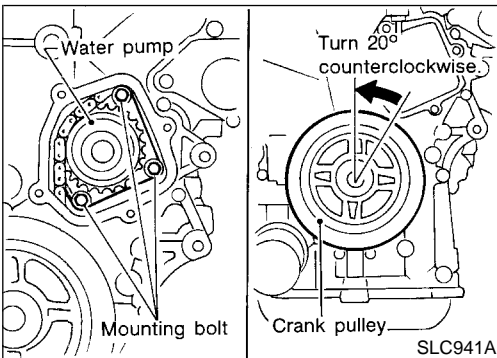

10. Remove the 3 water pump fixing bolts. Secure a gap between water pump gear and timing chain, by turning crankshaft pulley 20° backwards.

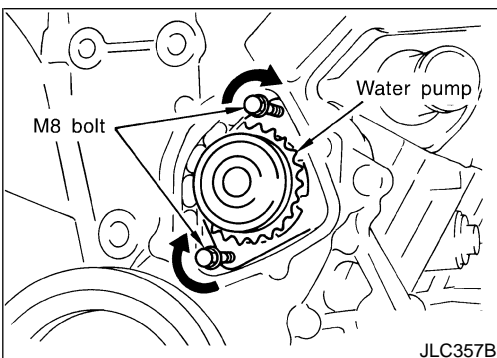

11. Put M8 bolts [pitch: 1.25 mm (0.0492 in), length: approx. 50 mm (1.97 in)] to two water pump fixing bolt holes.

GI  
MA  
EM  
LC  
EC  
FE  
CL  
MT  
AT  
TF  
PD  
AX  
SU  
BR  
ST  
RS  
BT  
HA  
SC  
EL  
IDX

# ENGINE COOLING SYSTEM

## Water Pump (Cont'd)

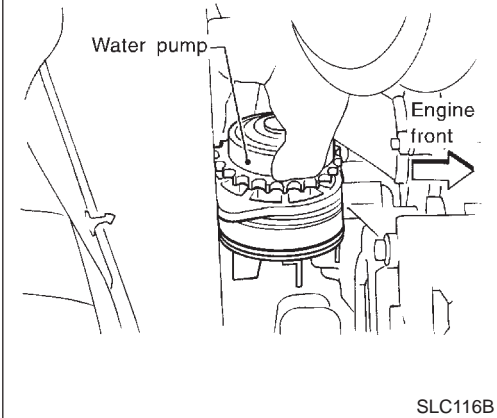
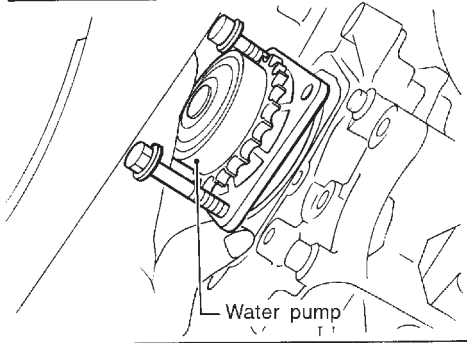
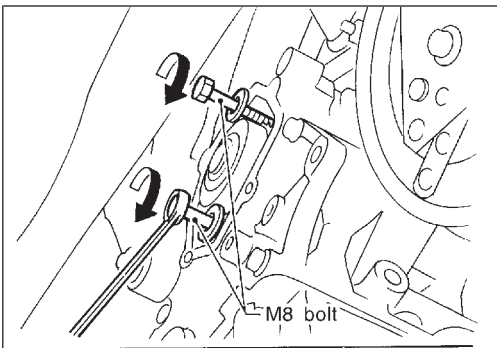

SLC116B

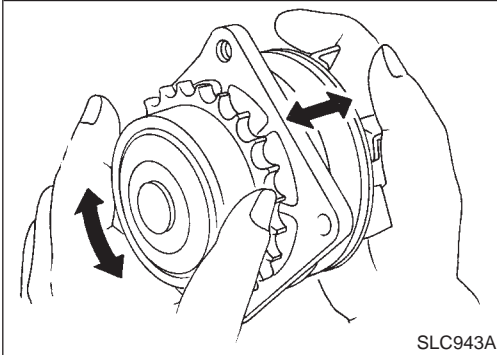

SLC943A

12. Tighten M8 bolts by turning half turn alternately until they reach timing chain rear case.
  - In order to prevent damages to water pump or timing chain rear case, do not tighten one bolt continuously. Always turn each bolt half turn each time.
13. Lift up water pump and remove it.
  - When lifting up water pump, do not allow water pump gear to hit timing chain.

### INSPECTION

1. Check for badly rusted or corroded body assembly.
2. Check for rough operation due to excessive end play.

NALC0019



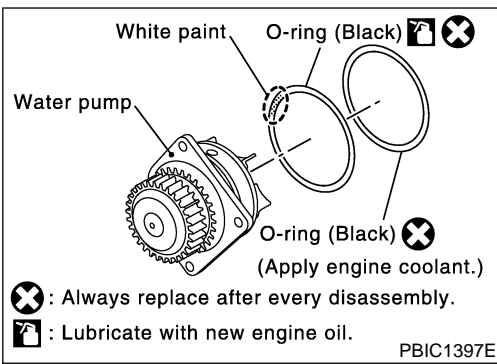

## INSTALLATION

=NALC0020

1. Apply engine oil and engine coolant to O-rings as shown in the figure.
  - Install O-ring with a white paint mark to the front side.

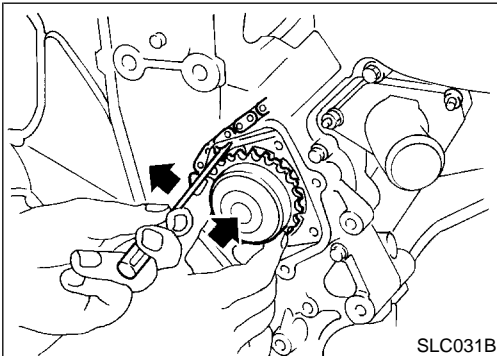

2. Install water pump.
  - Do not allow cylinder block to nip O-rings when installing water pump.

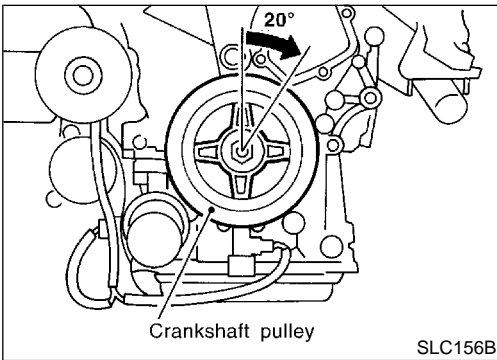

3. Return the crankshaft pulley to its original position by turning it 20° forward.

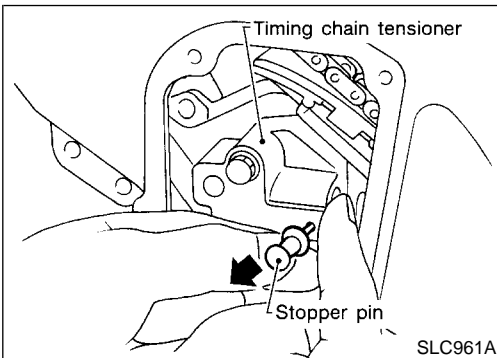

4. Install timing chain tensioner, then remove the stopper pin.
  - When installing the timing chain tensioner, engine oil should be applied to the oil hole and tensioner.

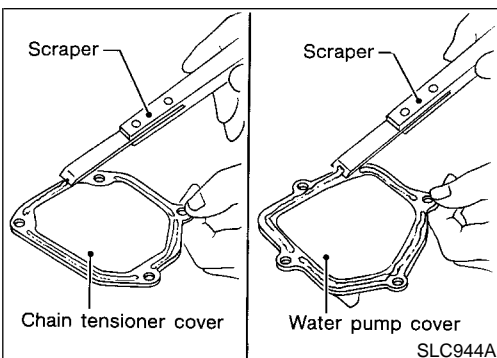

5. Install chain tensioner cover and water pump cover.
  - a. Before installing, remove all traces of liquid gasket from mating surface of water pump cover and chain tensioner cover using a scraper. Also remove traces of liquid gasket from mating surface of front cover.

GI  
MA  
EM  
LC  
EC  
FE  
CL  
MT  
AT  
TF  
PD  
AX  
SU  
BR  
ST  
RS  
BT  
HA  
SC  
EL  
IDX

# ENGINE COOLING SYSTEM

## Water Pump (Cont'd)

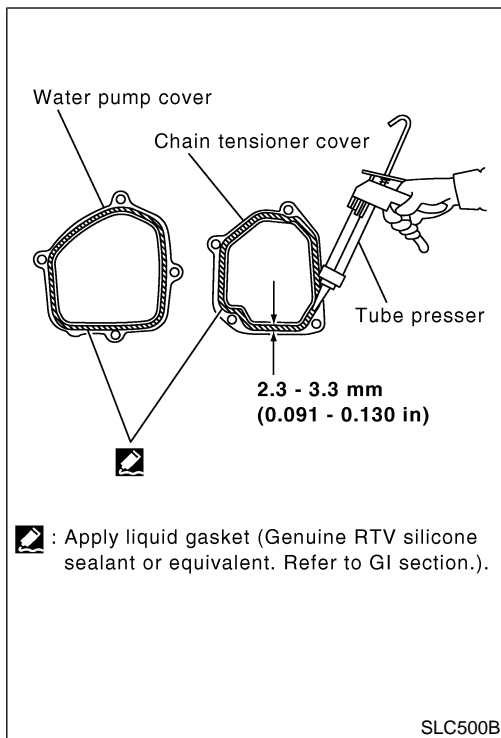

- b. Apply a continuous bead of liquid gasket to mating surface of chain tensioner cover and water pump cover.

**Use Genuine RTV silicone sealant or equivalent. Refer to GI-53.**

6. Reinstall any parts removed in reverse order of removal.
- **After starting engine, let idle for three minutes, then rev engine up to 3,000 rpm under no load to purge air from the high-pressure chamber of the chain tensioners. The engine may produce a rattling noise. This indicates that air still remains in the chamber and is not a matter of concern.**

## Thermostat REMOVAL AND INSTALLATION

=NALC0021

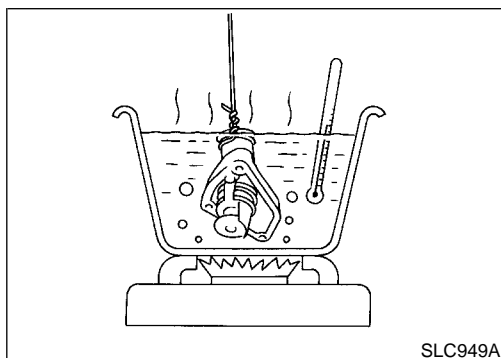
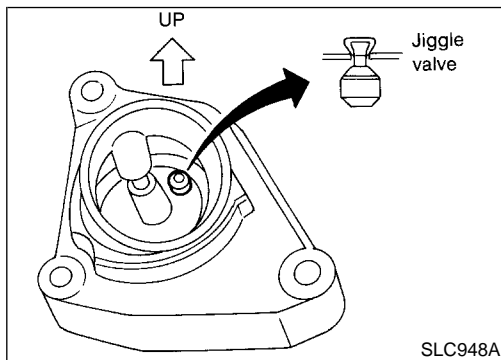
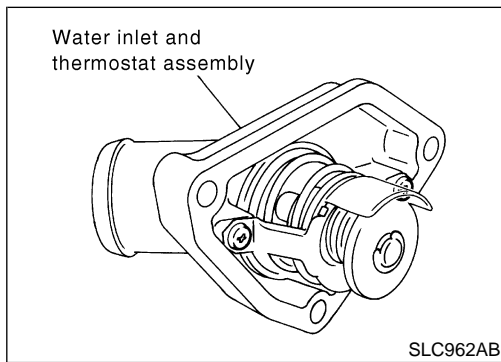
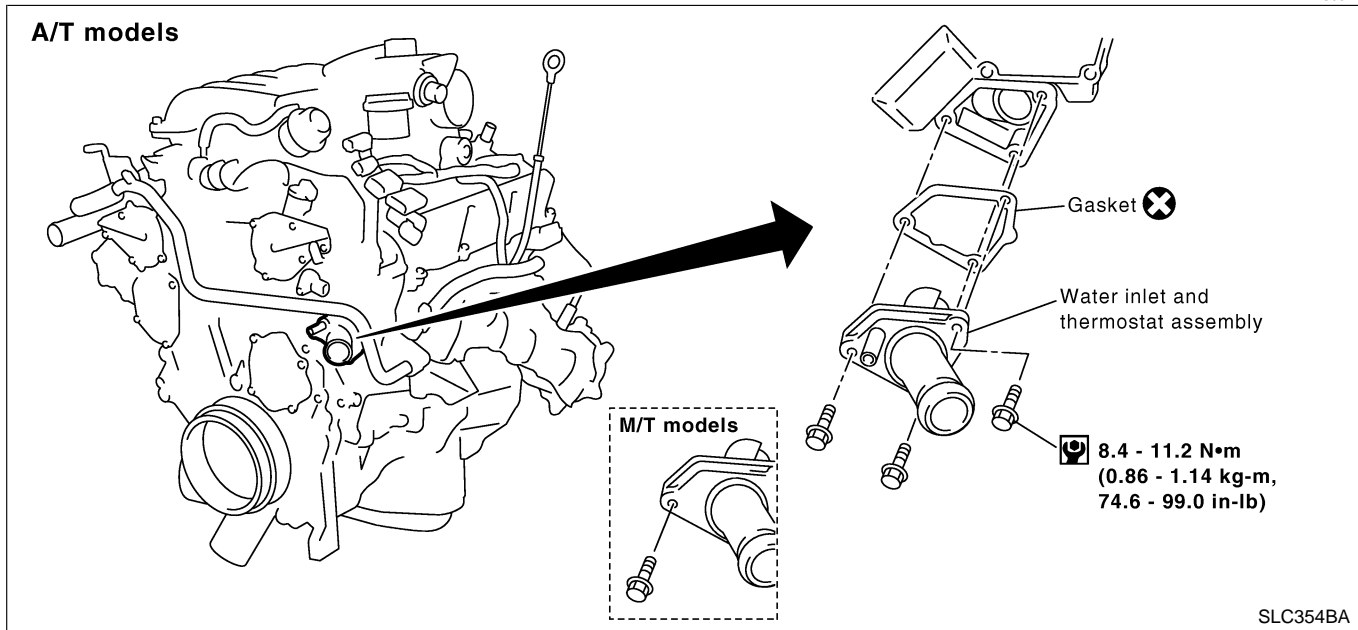

1. Remove undercover.
2. Remove suspension member stay.
3. Drain engine coolant from radiator.
4. Remove drive belts.
5. Remove water drain plug on water pump side of cylinder block.
6. Disconnect lower radiator hose.
7. Remove water inlet and thermostat assembly.
- **Do not disassemble water inlet and thermostat assembly. Replace them as a unit, if necessary.**
8. Install thermostat with jiggle valve facing upward.
- **After installation, run engine for a few minutes, and check for leaks.**
- **Be careful not to spill engine coolant over engine compartment. Use a rag to absorb engine coolant.**
9. Reinstall any removed parts in reverse order of removal.

### INSPECTION

NALC0022

1. Check valve seating condition at ordinary room temperatures. It should seat tightly.
2. Check valve opening temperature and maximum valve lift.

	Standard
Valve opening temperature	76.5°C (170°F)
Valve lift	More than 8.6 mm/90°C (0.339 in/194°F)

GI  
MA  
EM  
LC  
EC  
FE  
CL  
MT  
AT  
TF  
PD  
AX  
SU  
BR  
ST  
RS  
BT  
HA  
SC  
EL  
IDX

# ENGINE COOLING SYSTEM

Thermostat (Cont'd)

3. Then check if valve closes at 5°C (9°F) below valve opening temperature.

## Water Control Valve REMOVAL AND INSTALLATION

NALC0032

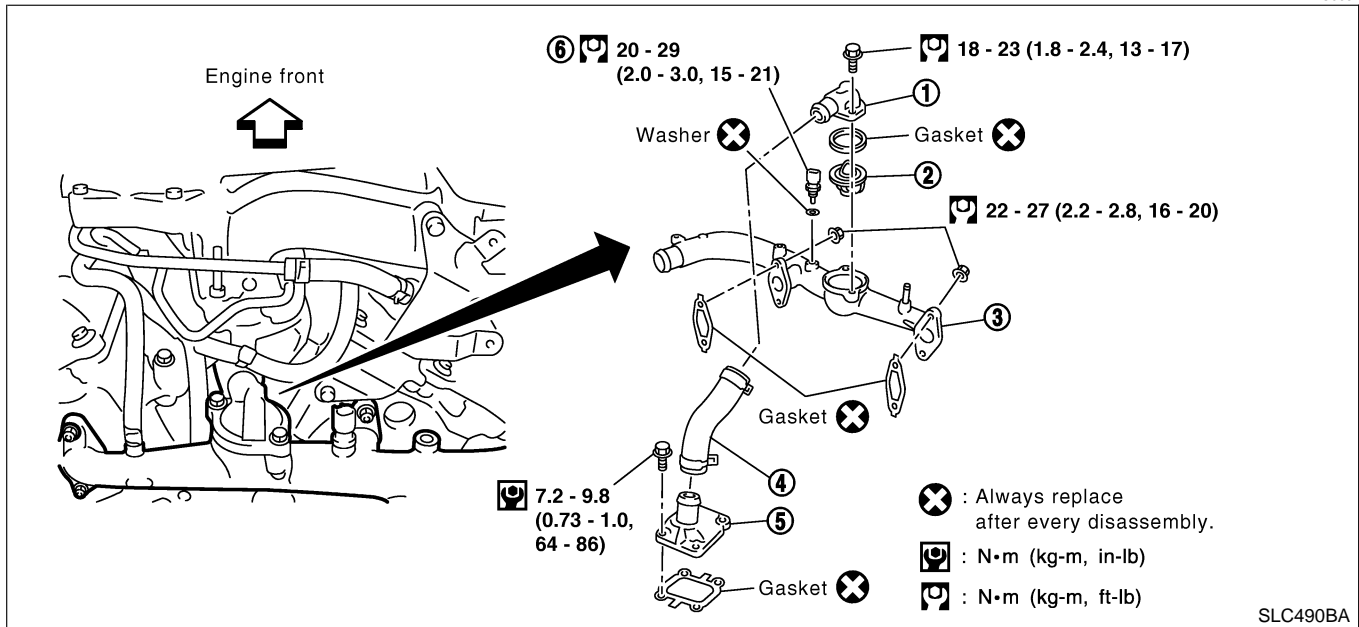

1. Water outlet housing
2. Water control valve

3. Water outlet
4. Water hose

5. Cylinder block water outlet
6. Engine coolant temperature sensor

1. Release fuel pressure. Refer to EC-56, "Fuel Pressure Release".
2. Remove undercover.
3. Remove suspension member stay.
4. Drain engine coolant from radiator.
5. Remove engine cover.
6. Remove air duct with air cleaner assembly.
7. Disconnect hoses, harness and so on.
8. Remove upper intake manifold corrector.
9. Remove intake manifold corrector support bolts.
10. Remove lower intake manifold corrector.
11. Disconnect injector harness connectors.
12. Remove injector tube.
13. Remove intake manifold.
14. Remove water outlet housing and water control valve.

# ENGINE COOLING SYSTEM

Water Control Valve (Cont'd)

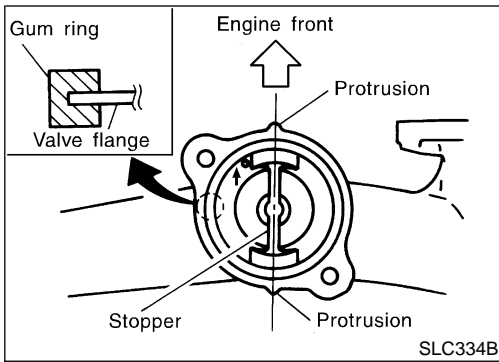

15. Install water control valve and water outlet housing.
  - a. Install gum ring to thermostat.
  - b. Point the arrow on the upper surface of the valve to the front of the engine, and also be sure to install the protrusions and the valve stopper so that they are aligned in a straight line.
16. Reinstall any removed parts in reverse order of removal.
  - **When installing intake manifold, injector tube and intake manifold collectors, refer to EM-12, "TIGHTENING PROCEDURES".**
  - **After installation, run engine for a few minutes, and check for leaks.**
  - **Be careful not to spill engine coolant over engine compartment. Use a rag to absorb engine coolant.**

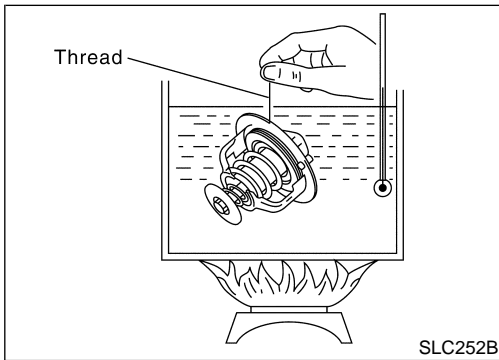

## INSPECTION

NALC0033

1. Check valve seating condition at ordinary room temperatures. It should seat tightly.
2. Check valve opening temperature and maximum valve lift.

	Standard
Valve opening temperature	95°C (203°F)
Valve lift	More than 8.0 mm/108°C (0.315 in/226°F)

3. Then check if valve closes at 5°C (9°F) below valve opening temperature.

GI  
MA  
EM  
LC  
EC  
FE  
CL  
MT  
AT  
TF  
PD  
AX  
SU  
BR  
ST  
RS  
BT  
HA  
SC  
EL  
IDX

# ENGINE COOLING SYSTEM

Radiator

## Radiator

### REMOVAL AND INSTALLATION

=NALC0023

1. Remove undercover.
2. Remove suspension member stay.
3. Drain engine coolant from radiator.
4. Disconnect radiator upper and lower hoses.
5. Remove upper and lower radiator shroud.
6. Remove A/T oil cooler hoses. (A/T)
7. Disconnect reservoir tank hose.
8. Remove radiator mounting bracket.
9. Remove radiator.
10. After repairing or replacing radiator, install any part removed in reverse order of removal.

When filling radiator with engine coolant, refer to MA-15, "Changing Engine Coolant".

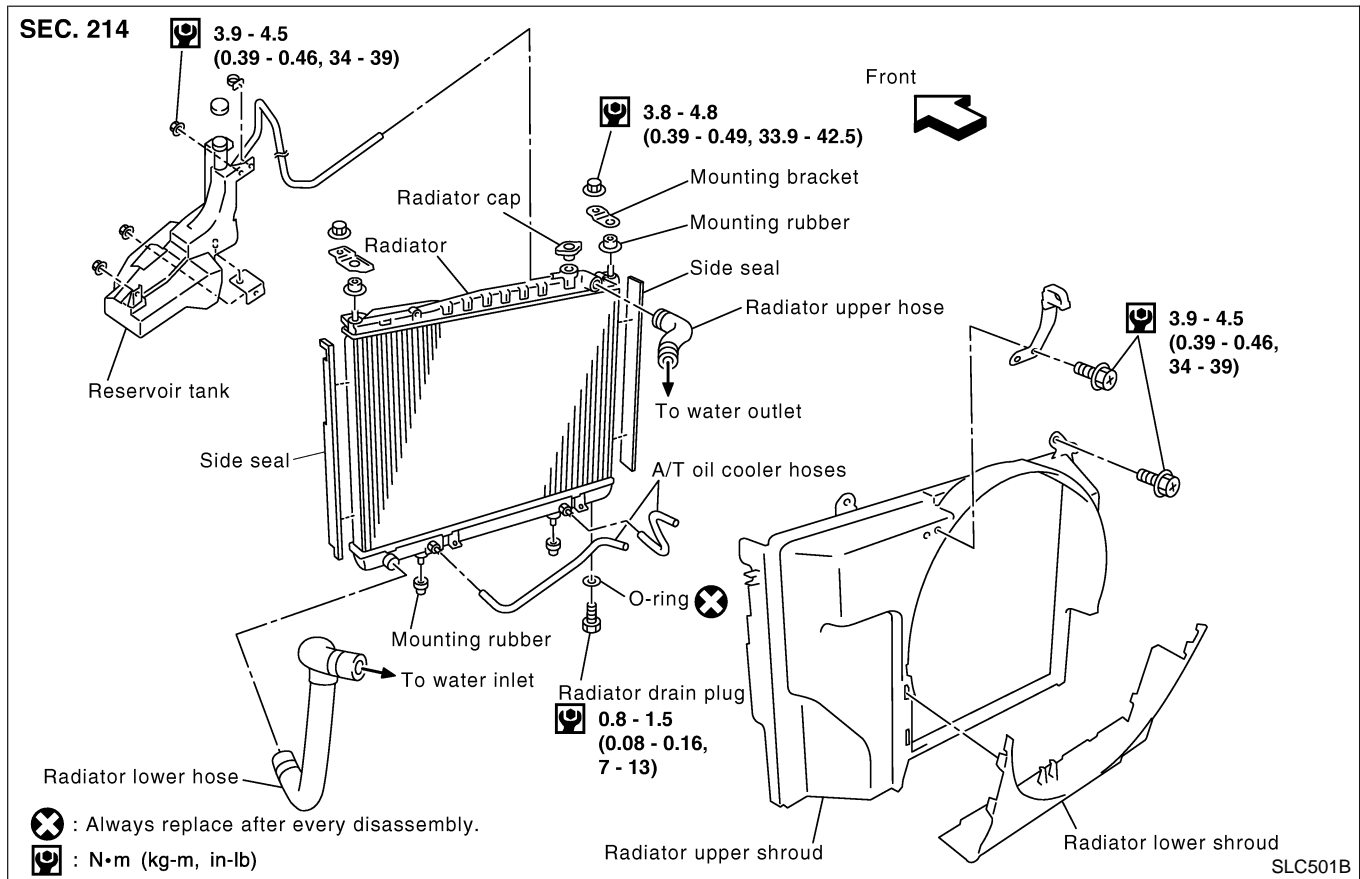

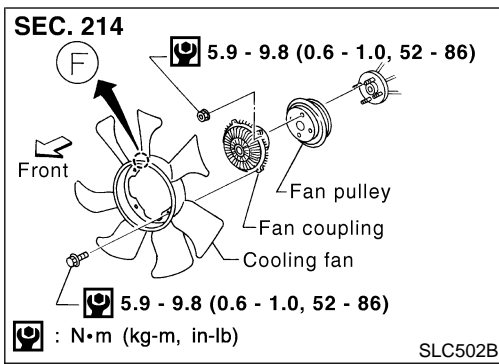

## Cooling Fan (Crankshaft driven)

### REMOVAL AND INSTALLATION

- Do not release the drive belt tension by removing the fan pulley.
- Fan coupling cannot be disassembled and should be replaced as a unit. If front mark **F** is present, install fan so that side marked **F** faces the front.
- Install the drive belt only after the fan and fan coupling to fan pulley bracket flange bolts/nuts have been properly torqued.

=NALC0038

GI

MA

EM

LC

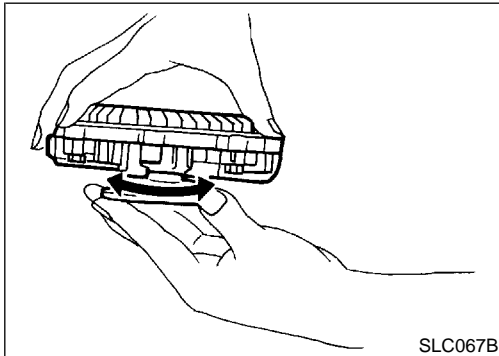

### INSPECTION

Check fan coupling for rough operation, wobbling, oil leakage or bent bimetal.

NALC0039

After assembly, verify the fan does not wobble or flap while the engine is running.

### WARNING:

- When the engine is running, keep hands and clothing away from moving parts such as drive belts and fan.

EC

FE

CL

MT

## Refilling Engine Coolant

For details on refilling engine coolant, refer to MA-16, "REFILLING ENGINE COOLANT".

NALC0034

AT

TF

PD

AX

SU

BR

ST

RS

BT

HA

SC

EL

IDX

# ENGINE COOLING SYSTEM

Radiator (Aluminum type)

## Radiator (Aluminum type) PREPARATION

=NALC0025

### SEC. 214

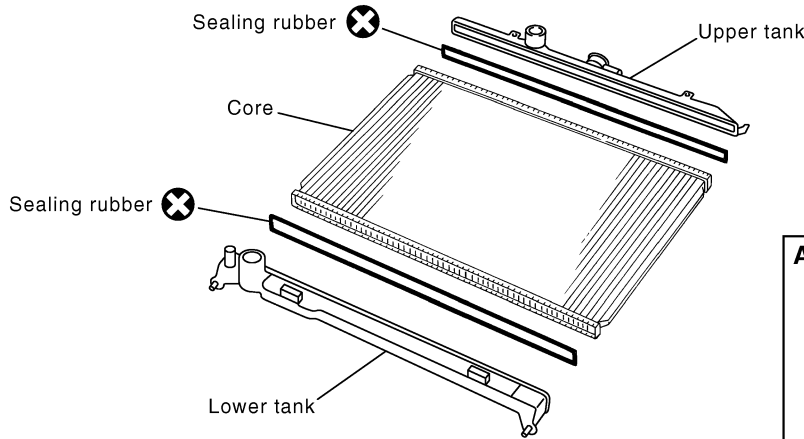

⊗: Always replace after every disassembly.

### A/T models

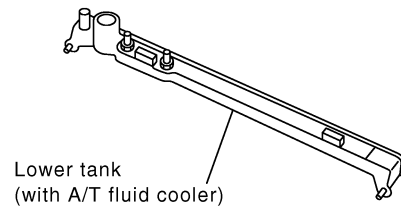

SLC579B

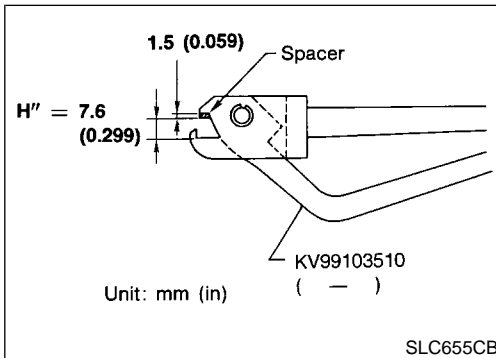

SLC655CB

1. Attach the spacer to the tip of the radiator plate pliers A. Spacer specification: 1.5 mm (0.059 in) thick x 18 mm (0.71 in) wide x 8.5 mm (0.335 in) long.
2. Make sure that when radiator plate pliers A are closed dimension H'' is approx. 7.6 mm (0.299 in).
3. Adjust dimension H'' with the spacer, if necessary.

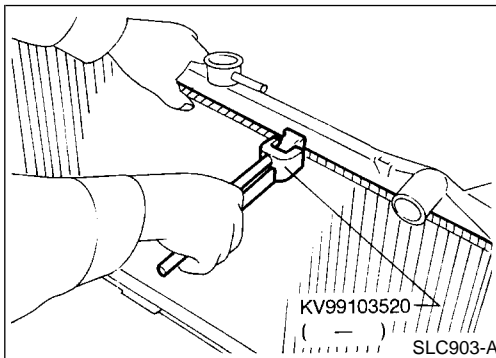

SLC903-A

### DISASSEMBLY

NALC0026

1. Remove upper and lower tanks with Tool.

**CAUTION:**  
Do not disassemble lower tank and A/T fluid cooler. (A/T models)

**NOTE:**  
Regard lower tank and A/T fluid cooler as an assembly.

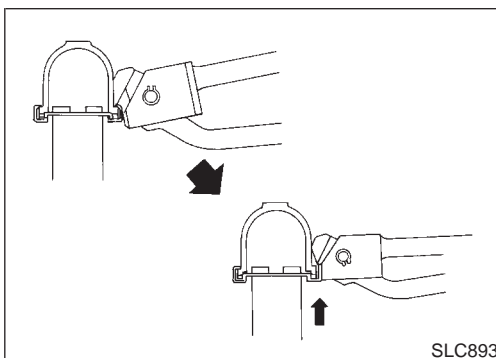

SLC893

- Grip the crimped edge and bend it upwards so that Tool slips off.

**Do not bend excessively.**



# ENGINE COOLING SYSTEM

Radiator (Aluminum type) (Cont'd)

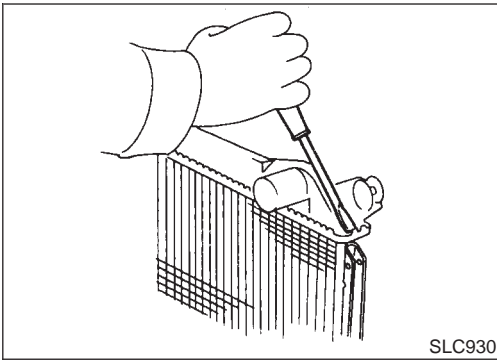

- In areas where Tool cannot be used, use a screwdriver to bend the edge up.

**Be careful not to damage tank.**

2. Remove sealing rubbers.

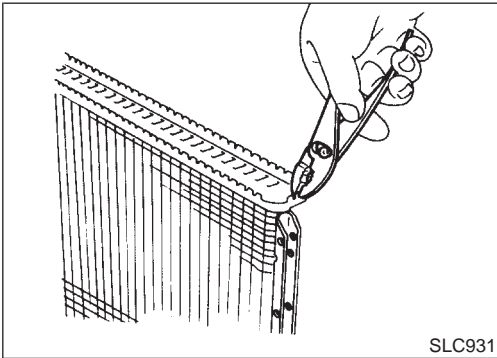

3. Make sure the edge stands straight up.

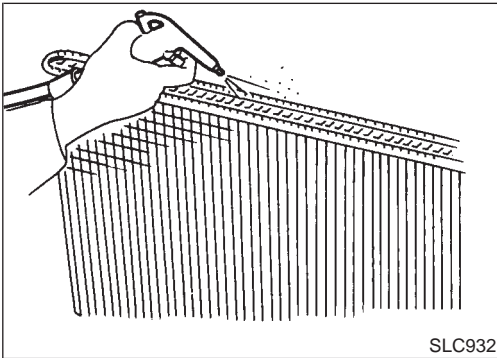

## ASSEMBLY

1. Clean contact portion of tank.

NALC0027

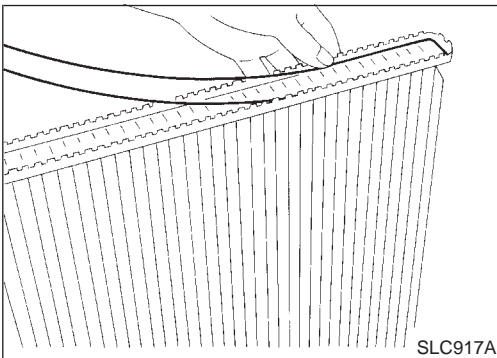

2. Install sealing rubber.

**Push it in with fingers.**

**Be careful not to twist sealing rubber.**

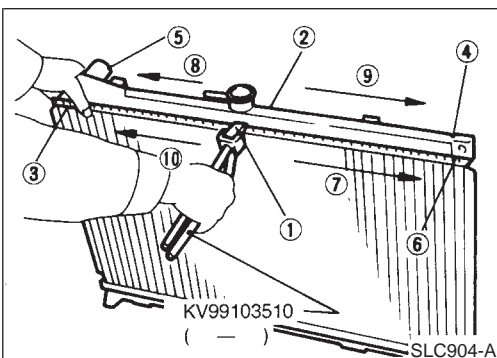

3. Caulk tank in specified sequence with Tool.

GI  
MA  
EM  
**LC**  
EC  
FE  
CL  
MT  
AT  
TF  
PD  
AX  
SU  
BR  
ST  
RS  
BT  
HA  
SC  
EL  
IDX

# ENGINE COOLING SYSTEM

Radiator (Aluminum type) (Cont'd)

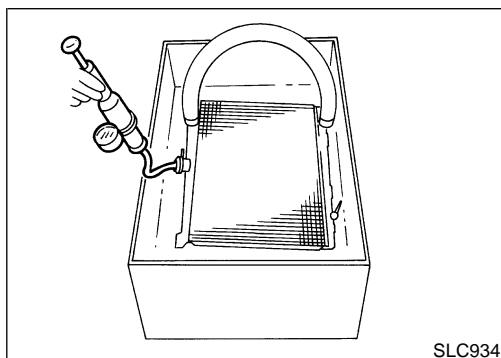
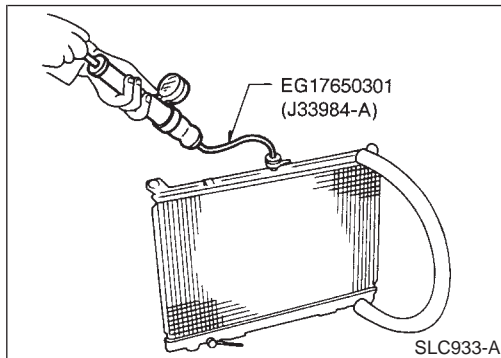
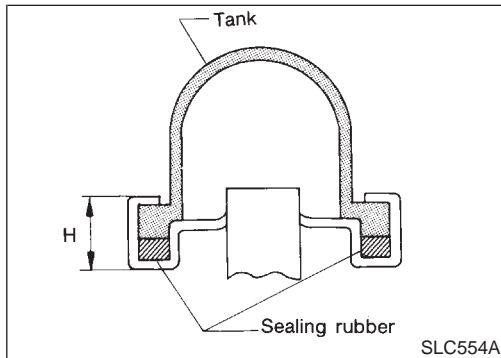
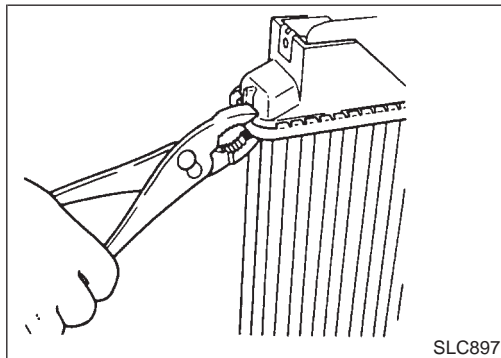
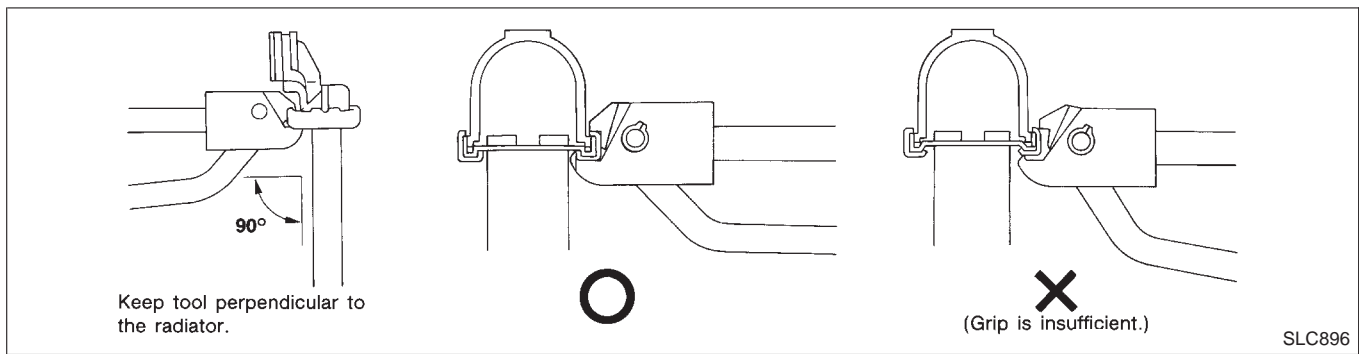

- Use pliers in the locations where Tool cannot be used.

4. Make sure that the rim is completely crimped down.

**Standard height "H":**

**8.0 - 8.4 mm (0.315 - 0.331 in)**

5. Confirm that there is no leakage.

**Refer to Inspection.**

## INSPECTION

1. Apply pressure with radiator cap tester (commercial service tool) and Tool.

**Specified pressure value:**

**157 kPa (1.6 kg/cm<sup>2</sup>, 23 psi)**

### **WARNING:**

To prevent the risk of the hose coming undone while under pressure, securely fasten it down with a hose clamp.

Attach a hose to the oil cooler to seal its inlet and outlet. (A/T models only)

2. Check for leakage by soaking radiator in water container.

# ENGINE COOLING SYSTEM

Overheating Cause Analysis

## Overheating Cause Analysis

NALC0029

		Symptom	Check items			
Cooling system parts malfunction	Poor heat transfer	Water pump malfunction	Worn or loose drive belt	—	GI	
		Thermostat stuck closed	—		MA	
		Damaged fins	Dust contamination or paper clogging		—	EM
			Physical damage			LC
		Clogged radiator cooling tube	Excess foreign material (rust, dirt, sand, etc.)		EC	
	Reduced air flow	Cooling fan does not operate	Fan assembly	—	FE	
		High resistance to fan rotation			CL	
		Damaged fan blades				
		Damaged radiator shroud	—	—	MT	
		Improper coolant mixture ratio	—	—		
		Poor coolant quality	—	Coolant density	—	AT
	Insufficient coolant	Coolant leaks	Cooling hose	Loose clamp	TF	
				Cracked hose		
			Water pump	Poor sealing	PD	
			Radiator cap	Loose	AX	
				Poor sealing	SU	
			Radiator	O-ring for damage, deterioration or improper fitting	BR	
		Cracked radiator tank				
			Cracked radiator core			
		Reservoir tank	Cracked reservoir tank			
Overflowing reservoir tank	Exhaust gas leaks into cooling system	Cylinder head deterioration	ST			
		Cylinder head gasket deterioration	RS			

# ENGINE COOLING SYSTEM

Overheating Cause Analysis (Cont'd)

	Symptom		Check items	
Except cooling system parts malfunction	—	Overload on engine	Abusive driving	High engine rpm under no load
				Driving in low gear for extended time
				Driving at extremely high speed
			Powertrain system malfunction	—
			Installed improper size wheels and tires	
			Dragging brakes	
	Improper ignition timing			
	Blocked or restricted air flow	Blocked bumper	—	—
		Blocked radiator grille	Installed car brassiere	
			Mud contamination or paper clogging	
Blocked radiator		—		
Blocked condenser		Blocked airflow		
Installed large fog lamp				

## Service Data and Specifications (SDS)

### THERMOSTAT

NALC0030

Valve opening temperature	76.5°C (170°F)
Valve lift	More than 8.6 mm/90°C (0.339 in/194°F)

### WATER CONTROL VALVE

NALC0035

Valve opening temperature	95°C (203°F)
Valve lift	More than 8.0 mm/108°C (0.315 in/226°F)

### RADIATOR

Unit: kPa (kg/cm<sup>2</sup>, psi) NALC0031

Cap relief pressure	Standard	78 - 98 (0.8 - 1.0, 11 - 14)
	Limit	59 (0.6, 9)
Leakage test pressure		157 (1.6, 23)