

ENGINE MECHANICAL

SECTION **EM**

CONTENTS

PRECAUTIONS	2	CAMSHAFT VISUAL CHECK.....	30
Parts Requiring Angular Tightening.....	2	CAMSHAFT RUNOUT.....	30
Liquid Gasket Application Procedure	2	CAMSHAFT CAM HEIGHT	30
PREPARATION	3	CAMSHAFT JOURNAL CLEARANCE.....	31
Special Service Tools	3	CAMSHAFT END PLAY.....	31
Commercial Service Tools.....	5	CAMSHAFT SPROCKET RUNOUT	32
NOISE, VIBRATION AND HARSHNESS (NVH)		VALVE GUIDE CLEARANCE	32
TROUBLESHOOTING	7	VALVE GUIDE REPLACEMENT.....	32
NVH Troubleshooting Chart — Engine Noise.....	8	VALVE SEATS.....	33
OUTER COMPONENT PARTS	9	REPLACING VALVE SEAT FOR SERVICE PARTS	33
Removal and Installation	9	VALVE DIMENSIONS.....	34
WARM-UP THREE WAY CATALYST LH.....	11	VALVE SPRING.....	34
MEASUREMENT OF COMPRESSION PRESSURE	12	ROCKER SHAFT AND ROCKER ARM	35
OIL PAN	14	HYDRAULIC VALVE LIFTER	35
Removal.....	14	Assembly	36
Installation.....	15	Installation.....	36
TIMING BELT	17	ENGINE ASSEMBLY	41
Components.....	17	Removal and Installation	41
Removal.....	18	REMOVAL.....	42
Inspection.....	19	CYLINDER BLOCK	44
BELT TENSIONER AND TENSIONER SPRING	20	Components.....	44
Installation.....	20	CYLINDER BLOCK HEATER.....	45
Tension Adjustment.....	21	Removal and Installation	45
AFTER BELT REPLACEMENT.....	21	Disassembly.....	46
AFTER ENGINE OVERHAUL OR ENGINE		PISTON AND CRANKSHAFT.....	46
REASSEMBLY (WITH ROCKER COVERS		Inspection.....	46
REMOVED).....	22	PISTON AND PISTON PIN CLEARANCE	46
OIL SEAL	24	PISTON RING SIDE CLEARANCE	47
Replacement.....	24	PISTON RING END GAP.....	47
VALVE OIL SEAL.....	24	CONNECTING ROD BEND AND TORSION	47
OIL SEAL INSTALLING DIRECTION	24	CYLINDER BLOCK DISTORTION AND WEAR.....	48
CAMSHAFT OIL SEAL	25	PISTON-TO-BORE CLEARANCE.....	48
FRONT OIL SEAL.....	25	CRANKSHAFT.....	50
REAR OIL SEAL.....	25	BEARING CLEARANCE	50
CYLINDER HEAD	26	CONNECTING ROD BUSHING CLEARANCE	
Components.....	26	(SMALL END).....	53
Removal.....	27	REPLACEMENT OF CONNECTING ROD	
Disassembly.....	29	BUSHING (SMALL END)	53
Inspection.....	30	FLYWHEEL/DRIVE PLATE RUNOUT	53
CYLINDER HEAD DISTORTION	30	Assembly	54
		PISTON	54

CONTENTS (Cont'd)

CRANKSHAFT.....	54	Piston, Piston Ring and Piston Pin	64	GI
REPLACING PILOT BUSHING (M/T) OR PILOT		AVAILABLE PISTON	64	MA
CONVERTER (A/T).....	56	PISTON RING	64	
SERVICE DATA AND SPECIFICATIONS (SDS)	57	PISTON PIN	65	EM
General Specifications.....	57	Connecting Rod	65	
Cylinder Head	58	Crankshaft.....	65	LC
Valve	58	Available Main Bearing	66	EC
VALVE	58	NO. 1 MAIN BEARING	66	FE
VALVE SPRING	59	NO. 2 AND 3 MAIN BEARINGS	66	
HYDRAULIC VALVE LIFTER	59	NO. 4 MAIN BEARING	66	CL
VALVE GUIDE	59	UNDER SIZE.....	66	MT
ROCKER SHAFT AND ROCKER ARM	59	Available Connecting Rod Bearing.....	67	AT
Valve Seat.....	60	CONNECTING ROD BEARING UNDERSIZE	67	TF
INTAKE VALVE SEAT	60	Miscellaneous Components.....	67	PD
EXHAUST VALVE SEAT.....	61	BEARING CLEARANCE	67	AX
Camshaft and Camshaft Bearing	62			SU
Cylinder Block.....	63			BR
				ST
				RS
				BT
				HA
				SC
				EL
				IDX

PRECAUTIONS

Parts Requiring Angular Tightening

Parts Requiring Angular Tightening

NAEM0001

- Use an angle wrench for the final tightening of the following engine parts:
 - a) Cylinder head bolts
 - b) Main bearing cap bolts
 - c) Connecting rod cap nuts
 - d) Crankshaft pulley bolt
- Do not use a torque value for final tightening.
- The torque value for these parts are for a preliminary step.
- Ensure thread and seat surfaces are clean and coated with engine oil.

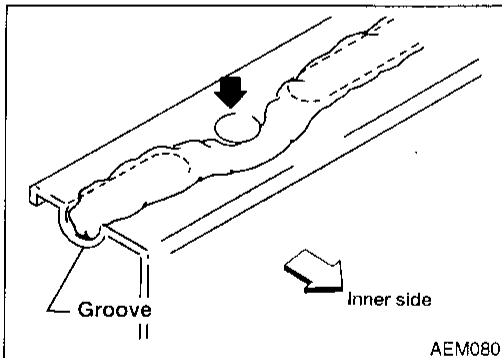
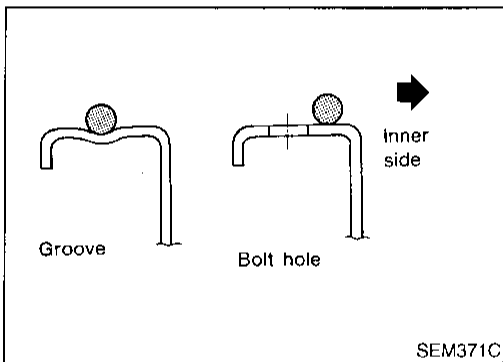

Liquid Gasket Application Procedure

NAEM0002

- 1) Use a scraper to remove all traces of old liquid gasket from mating surfaces and grooves. Also completely clean any oil stains from these portions.
- 2) Apply a continuous bead of liquid gasket to mating surfaces. (Use Genuine RTV silicone sealant Part No. 999MP-A7007 or equivalent.)
 - Be sure liquid gasket is 3.5 to 4.5 mm (0.138 to 0.177 in) dia. (for oil pan).
 - Be sure liquid gasket is 2.0 to 3.0 mm (0.079 to 0.118 in) dia. (in areas except oil pan).
- 3) Apply liquid gasket to inner surface around hole perimeter area (unless otherwise specified).
- 4) Assembly should be done within 5 minutes after coating.
- 5) Wait at least 30 minutes before refilling engine oil and engine coolant.

PREPARATION

Special Service Tools

Special Service Tools

NAEM0003

The actual shapes of Kent-Moore tools may differ from those of special service tools illustrated here.

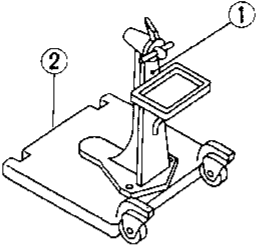
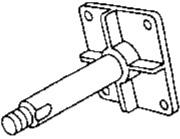
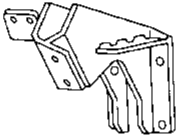
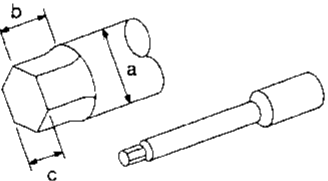
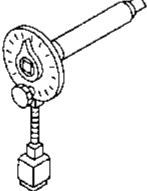
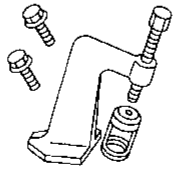
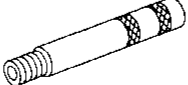
Tool number (Kent-Moore No.) Tool name	Description	GI
ST0501S000 (—) Engine stand assembly 1 ST05011000 (—) Engine stand 2 ST05012000 (—) Base	 <p>Disassembling and assembling</p> <p>NT042</p>	MA
KV10106500 (—) Engine stand shaft	 <p>NT028</p>	EM
KV10110001 (—) Engine sub-attachment	 <p>NT032</p>	LC
ST10120000 (J24239-01) Cylinder head bolt wrench	 <p>Loosening and tightening cylinder head bolt a: 13 mm (0.51 in) dia. b: 12 mm (0.47 in) c: 10 mm (0.39 in)</p> <p>NT583</p>	EC
KV10112100 (BT8653-A) Angle wrench	 <p>Tightening bearing cap, cylinder head bolts, etc.</p> <p>NT014</p>	FE
KV10110600 (J33986) Valve spring compressor	 <p>Disassembling and assembling valve components</p> <p>NT033</p>	CL
KV10107501 (—) Valve oil seal drift	 <p>Installing valve oil seal</p> <p>NT025</p>	MT

AT

TF

PD

AX

SU

BR

ST

RS

BT

HA

SC

EL

IDX

EM-3

95

PREPARATION

Special Service Tools (Cont'd)

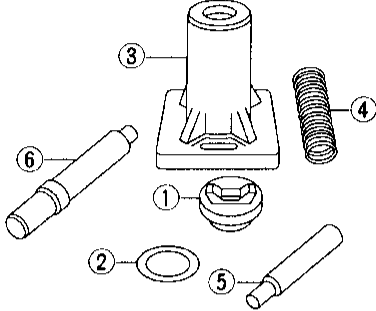
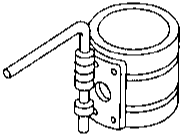
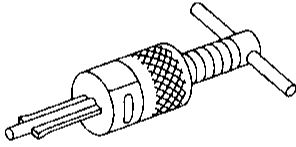
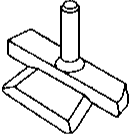
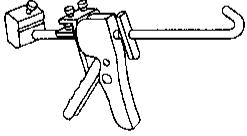
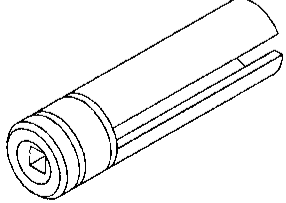
Tool number (Kent-Moore No.) Tool name	Description
KV10110300 (—) Piston pin press stand assembly 1 KV10110310 (—) Cap 2 KV10110330 (—) Spacer 3 ST13030020 (—) Press stand 4 ST13030030 (—) Spring 5 KV10110340 (—) Drift 6 KV10110320 (—) Center shaft	Disassembling and assembling piston with connecting rod  NT036
EM03470000 (J8037) Piston ring compressor	Installing piston assembly into cylinder bore  NT044
ST16610001 (J23907) Pilot bushing puller	Removing crankshaft pilot bushing  NT045
KV10111100 (J37228) Seal cutter	Removing oil pan  NT046
WS39930000 (—) Tube presser	Pressing the tube of liquid gasket  NT052
KV10117100 (J3647-A) Heated oxygen sensor wrench	Loosening or tightening heated oxygen sensor For 22 mm (0.87 in) hexagon nut  NT379

PREPARATION

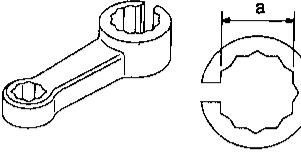

Special Service Tools (Cont'd)

Tool number (Kent-Moore No.) Tool name	Description	
KV10114400 (J38365) Heated oxygen sensor wrench		Loosening or tightening rear heated oxygen sensor (For right bank) a: 22 mm (0.87 in)
	NT636	

GI
MA
EM
LC

Commercial Service Tools

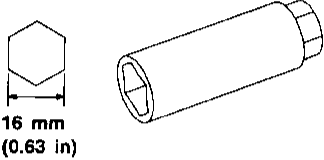
NAEM0004

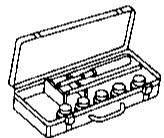
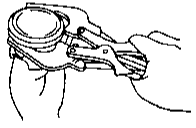
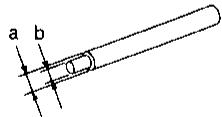
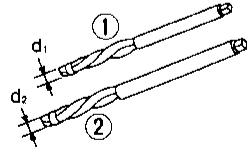
Tool name	Description	
Spark plug wrench		Removing and installing spark plug
	NT047	
Pulley holder		Holding camshaft pulley while tightening or loosening camshaft bolt
	NT035	
Valve seat cutter set		Finishing valve seat dimensions
	NT048	
Piston ring expander		Removing and installing piston ring
	NT030	
Valve guide drift		Removing and installing valve guide Intake & Exhaust: a = 10.5 mm (0.413 in) dia. b = 6.6 mm (0.260 in) dia.
	NT015	
Valve guide reamer		Reaming valve guide 1 or hole for oversize valve guide 2 Intake: d₁ = 7.0 mm (0.276 in) dia. d₂ = 11.2 mm (0.441 in) dia. Exhaust: d₁ = 8.0 mm (0.315 in) dia. d₂ = 12.2 mm (0.480 in) dia.
	NT016	

EC
FE
CL
MT
AT
TF
PD
AX
SU
BR
ST
RS
BT
HA
SC
EL
IDX

PREPARATION

Commercial Service Tools (Cont'd)

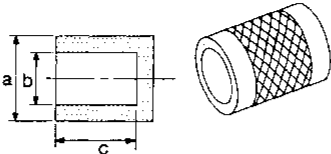
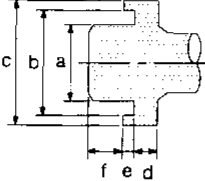
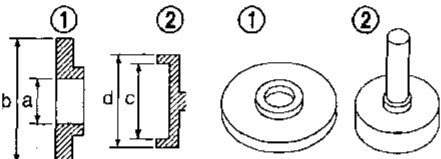
Tool name	Description
Camshaft oil seal drift	<div style="display: flex; align-items: center;">  <div style="margin-left: 20px;"> <p>Installing camshaft oil seal</p> <p>a: 60 mm (2.36 in) dia.</p> <p>b: 44.5 mm (1.752 in) dia.</p> <p>c: 75 mm (2.95 in)</p> </div> </div> <p style="margin-top: 10px;">NT613</p>
Front oil seal drift	<div style="display: flex; align-items: center;">  <div style="margin-left: 20px;"> <p>Installing front oil seal</p> <p>a: 24.5 mm (0.965 in) dia.</p> <p>b: 36 mm (1.42 in) dia.</p> <p>c: 44 mm (1.73 in) dia.</p> <p>d: 17 mm (0.67 in)</p> <p>e: 3 mm (0.12 in)</p> <p>f: 5 mm (0.20 in)</p> </div> </div> <p style="margin-top: 10px;">NT606</p>
Rear oil seal drift	<div style="display: flex; align-items: center;">  <div style="margin-left: 20px;"> <p>Installing rear oil seal</p> <p>a: 46 mm (1.81 in)</p> <p>b: 110 mm (4.33 in)</p> <p>c: 84 mm (3.31 in)</p> <p>d: 96 mm (3.78 in)</p> </div> </div> <p style="margin-top: 10px;">NT719</p>

NOISE, VIBRATION AND HARSHNESS (NVH) TROUBLESHOOTING

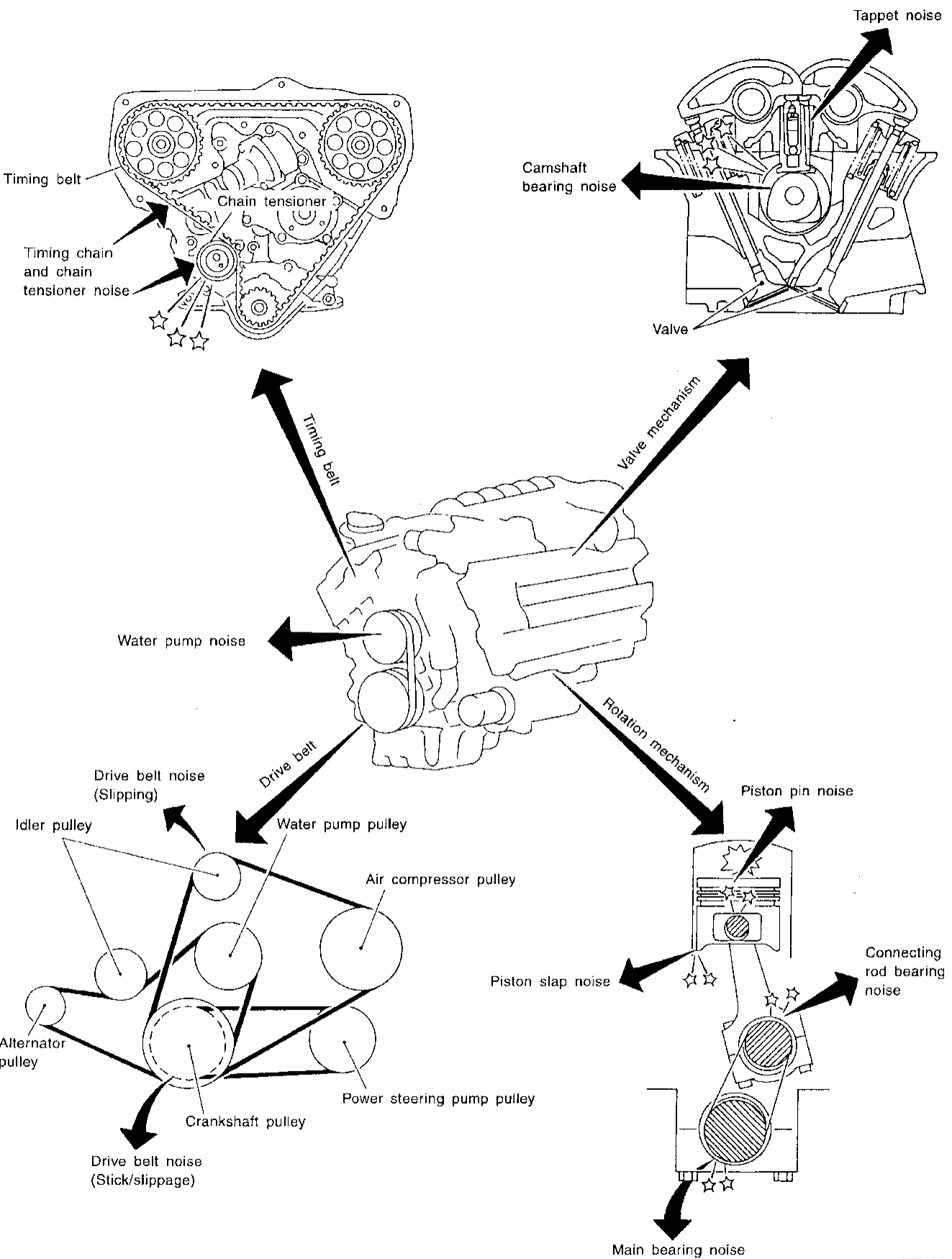

- GI
- MA
- EM**
- LC
- EC
- FE
- CL
- MT
- AT
- TF
- PD
- AX
- SU
- BR
- ST
- RS
- BT
- HA
- SC
- EL
- IDX

SEM645F

NOISE, VIBRATION AND HARSHNESS (NVH) TROUBLESHOOTING

NVH Troubleshooting Chart — Engine Noise

NVH Troubleshooting Chart — Engine Noise

NAEM0039S01

Use the chart below to help you find the cause of the problem.

1. Locate the area where noise occurs.
2. Confirm the type of noise.
3. Specify the operating condition of engine.
4. Check specified noise source.

If necessary, repair or replace these parts.

Location of noise	Type of noise	Operating condition of engine						Source of noise	Check item	Reference page
		Before warm-up	After warm-up	When starting	When idling	When racing	While driving			
Top of engine Rocker cover Cylinder head	Ticking or clicking	C	A	—	A	B	—	Tappet noise	Valve clearance	EM-36*1
	Rattle	C	A	—	A	B	C	Camshaft bearing noise	Camshaft journal clearance Camshaft runout	EM-31, EM-30
Crankshaft pulley Cylinder block (Side of engine) Oil pan	Slap or knock	—	A	—	B	B	—	Piston pin noise	Piston and piston pin clearance Connecting rod bushing clearance	EM-46, EM-53
	Slap or rap	A	—	—	B	B	A	Piston slap noise	Piston-to-bore clearance Piston ring side clearance Piston ring end gap Connecting rod bend and torsion	EM-48, EM-47, EM-47, EM-47
	Knock	A	B	C	B	B	B	Connecting rod bearing noise	Connecting rod bushing clearance (Small end) Connecting rod bearing clearance (Big end)	EM-53, EM-52
	Knock	A	B	—	A	B	C	Main bearing noise	Main bearing oil clearance Crankshaft runout	EM-50, EM-50
Timing belt cover	Whine or hissing	C	A	—	A	A	—	Timing belt noise (too tight)	Loose timing belt Belt contacting case	EM-17
	Clatter	A	B	—	C	A	—	Timing belt noise (too loose)		
Front of engine	Squeaking or fizzing	A	B	—	B	—	C	Other drive belts (Sticking or slipping)	Drive belts deflection	*2
	Creaking	A	B	A	B	A	B	Other drive belts (Slipping)	Idler pulley bearing operation	
	Squall Creak	A	B	—	B	A	B	Water pump noise	Water pump operation	*3

A: Closely related B: Related C: Sometimes related —: Not related

*1: STEP 19 in "Installation", "CYLINDER HEAD"

*2: MA section ("Checking Drive Belts", "ENGINE MAINTENANCE")

*3: LC section ("Water Pump Inspection", "ENGINE COOLING SYSTEM")

Removal and Installation

GI
 MA
EM
 LC
 EC
 FE
 CL
 MT
 AT
 TF
 PD
 AX
 SU
 BR
 ST
 RS
 BT
 HA
 SC
 EL
 IDX

SEC. 140•147•148•163•164•173•210•221

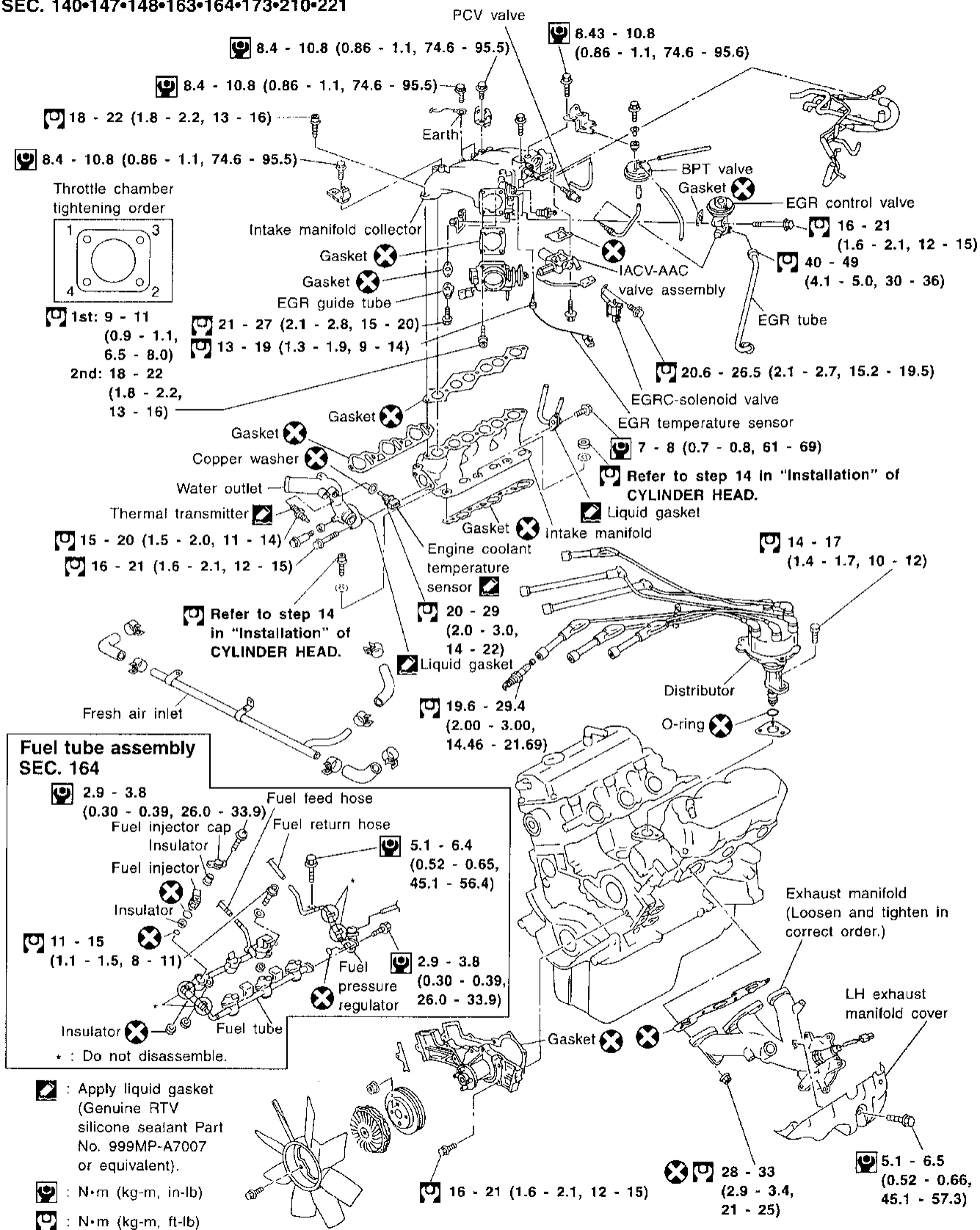

SEM644FC

OUTER COMPONENT PARTS

Removal and Installation (Cont'd)

SEC. 140-208

16 - 21
(1.6 - 2.1, 12 - 15)

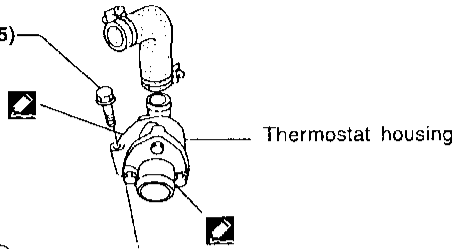

Thermostat housing

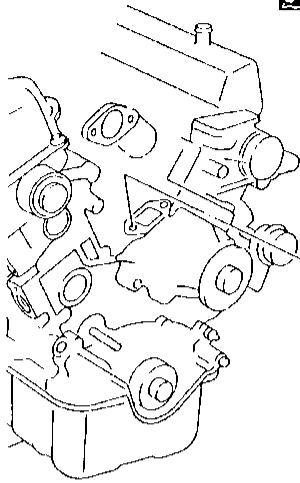

Oil filter bracket

5.1 - 6.5 (0.52 - 0.66, 45.1 - 57.3)

15 - 19 (1.5 - 1.9, 11 - 14)

8.4 - 10.8 (0.86 - 1.1, 74.6 - 95.5)

RH catalyst upper cover

RH exhaust manifold cover

Exhaust manifold (Right bank)

RH catalyst

Mesh washer
Washer

8.4 - 10.8 (0.86 - 1.1, 74.6 - 95.5)

RH catalyst lower cover

13 - 17
(1.3 - 1.7, 9 - 12)

15 - 19
(1.5 - 1.9, 11 - 14)

78 (8.0, 58)

40 - 60
(4.1 - 6.1, 30 - 44)

Front heated oxygen sensor

LH catalyst upper cover

28 - 33
(2.9 - 3.4, 21 - 25)

Gasket

15 - 19 (1.5 - 1.9, 11 - 14)

Gasket

Exhaust manifold (Left bank)

40 - 60
(4.1 - 6.1, 30 - 44)

Front heated oxygen sensor

LH catalyst upper cover

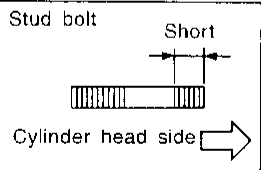

Stud bolt

Short

Cylinder head side

Stud bolt
13 - 17
(1.3 - 1.7, 9 - 12)

28 - 33
(2.9 - 3.4, 21 - 25)

LH exhaust manifold cover

5.1 - 6.5
(0.52 - 0.66, 45.1 - 57.3)

39 - 49 (4.0 - 5.0, 29 - 36)

39 - 49 (4.0 - 5.0, 29 - 36)

Washer
Mesh washer

LH catalyst

LH catalyst lower cover

EGR tube

15 - 19 (1.5 - 1.9, 11 - 14)

★: 24.5 - 29.4 (2.5 - 3.0, 18.1 - 21.7)

Apply liquid gasket (Genuine RTV silicone sealant Part No. 999MP-A7007 or equivalent).

N·m (kg-m, in-lb)

N·m (kg-m, ft-lb)

SEM334FC

OUTER COMPONENT PARTS

Removal and Installation (Cont'd)

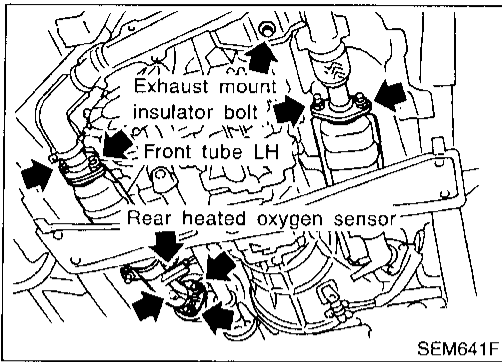

SEM641F

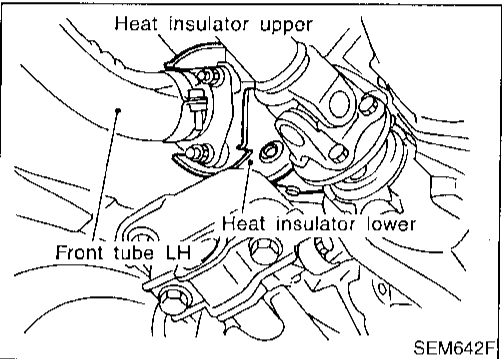

SEM642F

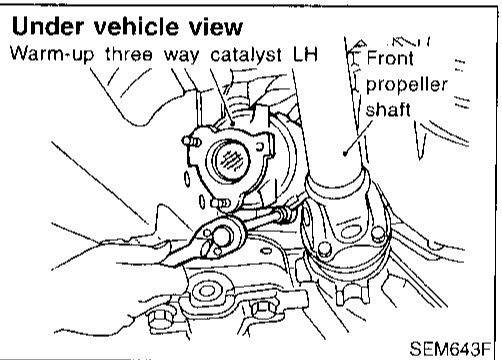

SEM643F

WARM-UP THREE WAY CATALYST LH

NAEM0005S01

1. Remove front tube nut RH and LH.
2. Loosen exhaust mount insulator bolt.
3. Remove rear heated oxygen sensor. Use SST KV10114400 (J38365).
4. Remove front tube LH side.
5. Remove heat insulator upper side.
6. Remove heat insulator lower side.
7. Remove warm-up three way catalyst.
8. Installation is in reverse order of removal.

GI

MA

EM

LC

EC

FE

CL

MT

AT

TF

PD

AX

SU

BR

ST

RS

BT

HA

SC

EL

IDX

MEASUREMENT OF COMPRESSION PRESSURE

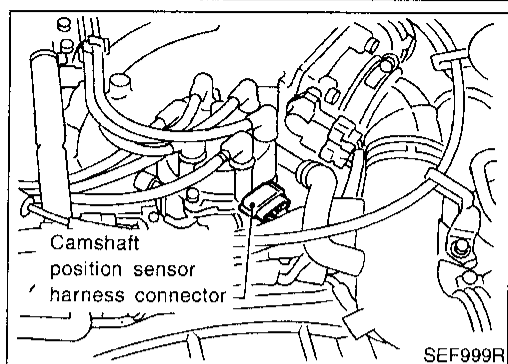

1. Warm up engine.
2. Turn ignition switch off.
3. Release fuel pressure.
Refer to "Releasing Fuel Pressure" in EC section.
4. Remove all spark plugs.
 - **Clean area around plug with compressed air before removing the spark plug.**
5. Disconnect camshaft position sensor harness connector at the distributor.
6. Remove fuel injector fuse 63 located in engine room.
Refer to "Terminal Arrangement", "FUSE AND FUSIBLE LINK BOX" in last page (Foldout page).

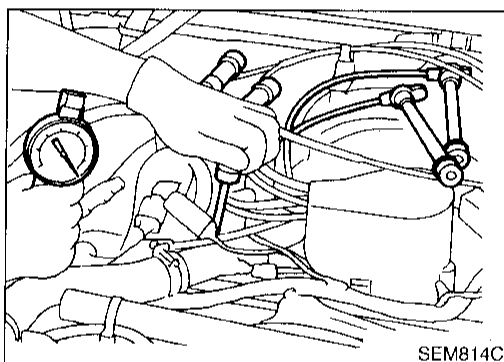

7. Attach a compression tester to No. 1 cylinder.
8. Depress accelerator pedal fully to keep throttle valve wide open.
9. Crank engine and record highest gauge indication.
10. Repeat the measurement on each cylinder as shown above.
 - **Always use a fully-charged battery to obtain specified engine speed.**

Compression pressure: kPa (kg/cm², psi)/300 rpm

Standard

1,196 (12.2, 173)

Minimum

883 (9.0, 128)

Maximum allowable difference between cylinders

98 (1.0, 14)

11. If cylinder compression in one or more cylinders is low, pour a small amount of engine oil into cylinders through spark plug holes and retest compression.
 - **If adding oil improves cylinder compression, piston rings may be worn or damaged. If so, replace piston rings after checking piston.**
 - **If pressure stays low, a valve may be sticking or seating improperly. Inspect and repair valve and valve seat. (Refer to SDS.) If valve or valve seat is damaged excessively, replace them.**
 - **If compression in any two adjacent cylinders is low and if adding oil does not improve compression, there is leakage past the gasket surface. If so, replace cylinder head gasket.**
12. Reinstall spark plug fuel injector fuse, fuel pump fuse, and reconnect camshaft position sensor harness connector at the distributor.
13. Erase the DTC stored in ECM.

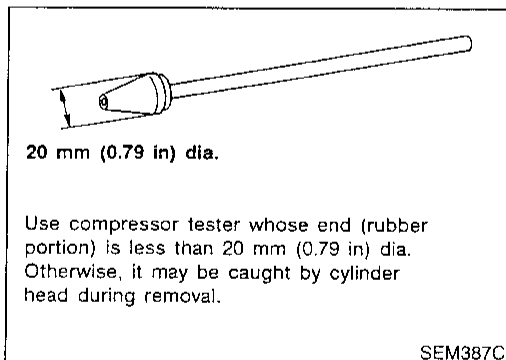

MEASUREMENT OF COMPRESSION PRESSURE

CAUTION:

Always erase the DTC after checking compression.

Refer to "HOW TO ERASE EMISSION-RELATED DIAGNOSTIC INFORMATION" in EC section.

GI

MA

EM

LC

EC

FE

CL

MT

AT

TF

PD

AX

SU

BR

ST

RS

BT

HA

SC

EL

IDX

OIL PAN

Removal

Removal

NAEM0007

Removal order and points		Applied model	
		2WD	4WD
1	Remove undercover.	○	○
2	Drain engine oil.	○	○
3	Remove stabilizer bracket bolts (RH & LH).	○	○
4	Remove front propeller shaft from front differential carrier.	—	○
5	Remove front drive shaft fixing bolts (RH & LH).	—	○
6	Remove front differential carrier bleeder hose.	—	○
7	Remove front suspension cross-member.	○	○
8	Remove differential front mounting bolts (RH & LH) and rear mounting bolts.	—	○
9	Remove front differential carrier.	—	○
10	Remove front differential carrier mounting bracket.	—	○
11	Remove starter motor.	○	○
12	Remove transmission to rear engine mounting bracket nuts (RH & LH).	○	○
13	Remove engine mounting bolts or nuts (RH & LH).	○	○
14	Remove power steering mounting brackets (RH & LH).	○	○
15	Lift up engine. If necessary, disconnect exhaust tube.	○	○
16	Remove oil pan.	○	○

WARNING:

- Place vehicle on a flat and solid surface.
- Place chocks at front and rear of rear wheels.
- You should not remove oil pan until exhaust system and cooling system have completely cooled off. Otherwise, you may burn yourself and/or fire may break out in the fuel line.
- When remove front and/or rear engine mounting bolts or nuts, lift up slightly engine for safety work.

CAUTION:

- In lifting engine, be careful not to hit against adjacent parts, especially against accelerator wire casing end, brake tube and brake master cylinder.

OIL PAN

Removal (Cont'd)

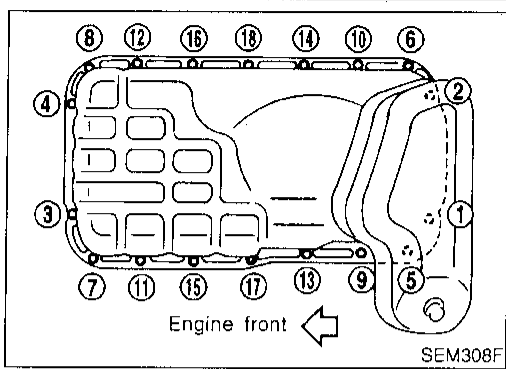

1. Remove oil pan bolts.

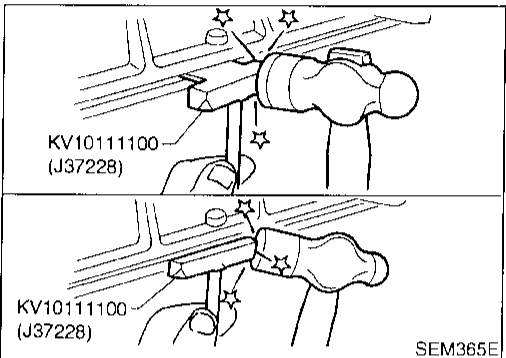

2. Remove oil pan.

- a. Insert Tool between cylinder block and oil pan.

- Do not drive seal cutter into oil pump or rear oil seal retainer portion, or aluminum mating face will be damaged.

- Do not insert screwdriver, or oil pan flange will be deformed.

- b. Slide Tool by tapping its side with a hammer, and remove oil pan.

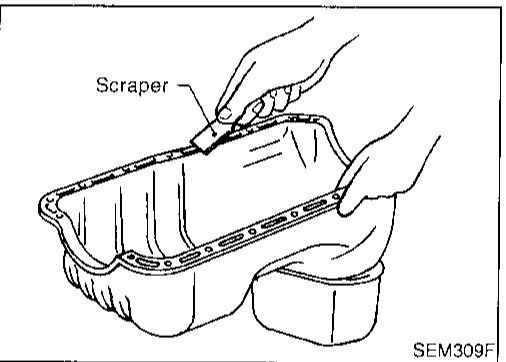

Installation

1. Before installing oil pan, remove all traces of liquid gasket from mating surface using a scraper. NAEM0008

- Also remove traces of liquid gasket from mating surface of cylinder block.

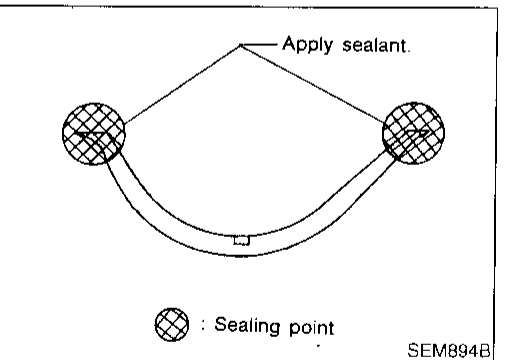

2. Apply sealant to oil pump gasket and rear oil seal retainer gasket.

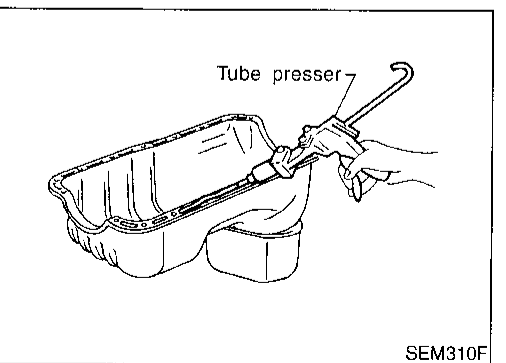

3. Apply a continuous bead of liquid gasket to mating surface of oil pan.

- Use Genuine RTV silicone sealant Part No. 999MP-A7007 or equivalent.

GI

MA

EM

LC

EC

FE

CL

MT

AT

TF

PD

AX

SU

BR

ST

RS

BT

HA

SC

EL

IDX

107

OIL PAN

Installation (Cont'd)

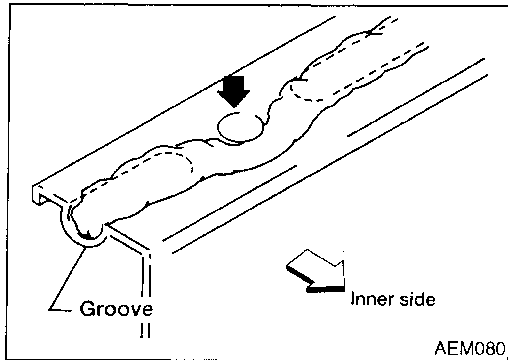
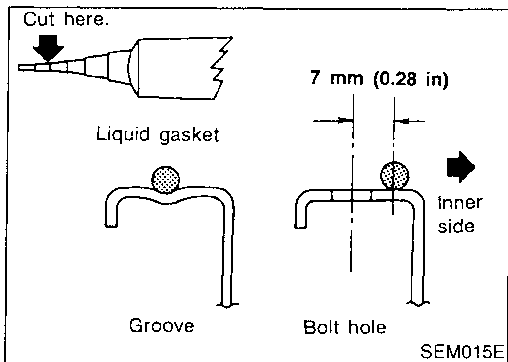

- Be sure liquid gasket is 3.5 to 4.5 mm (0.138 to 0.177 in) wide.
- 4. Apply liquid gasket to inner sealing surface as shown in figure.
- **Attaching should be done within 5 minutes after coating.**
- 5. Install oil pan.
- **Install bolts/nuts in their reverse order of removal.**
- **Wait at least 30 minutes before refilling engine oil.**

TIMING BELT

Components

Components

NAEM0009

CAUTION:

- Do not bend or twist timing belt.
- After removing timing belt, do not turn crankshaft and camshaft separately because valves will strike piston heads.
- Make sure that timing belt, camshaft sprocket, crankshaft sprocket and belt tensioner are clean and free from oil and water.
- Installation should be carried out when engine is cold.

SEC. 120•130•135

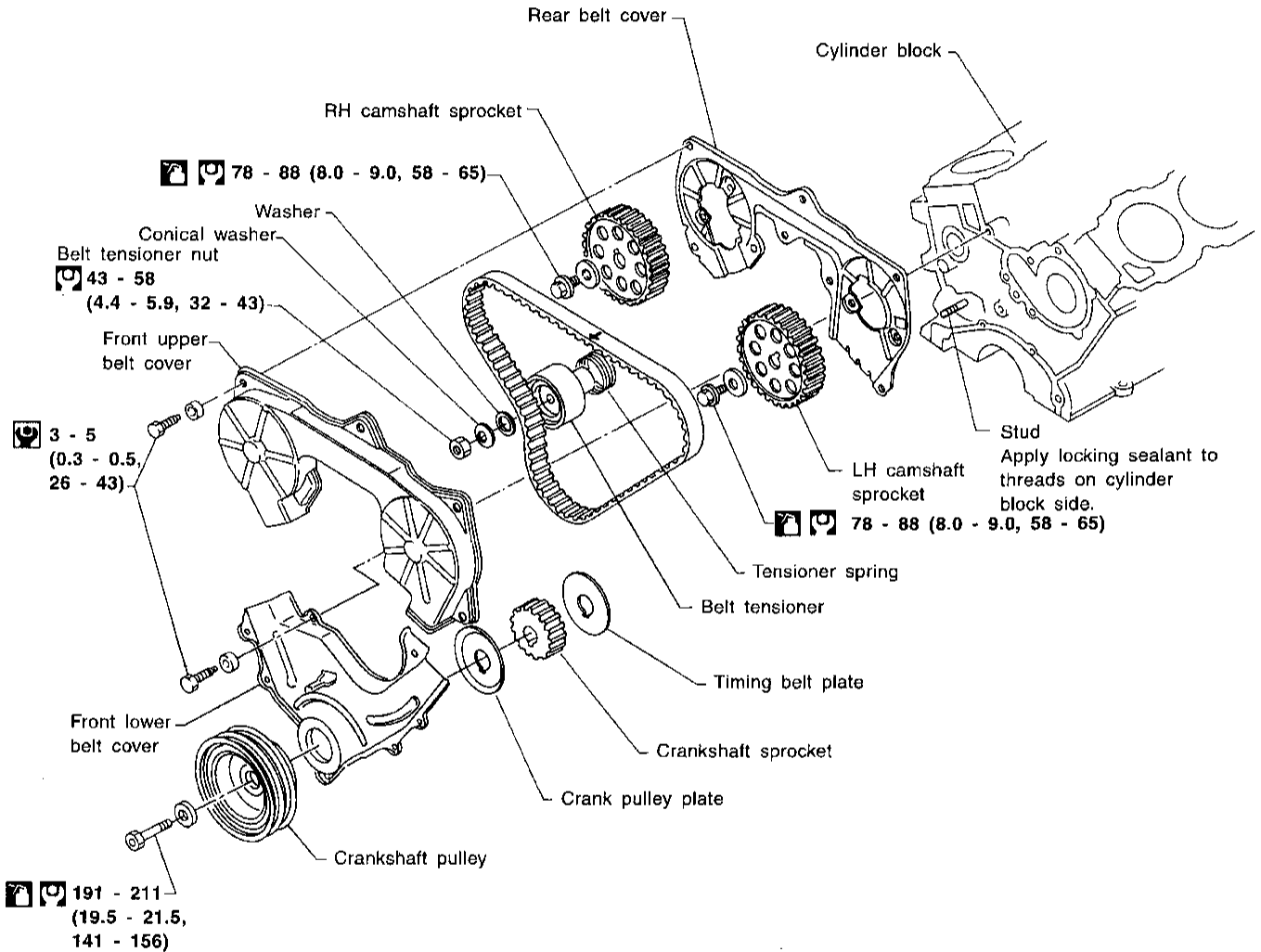

- ☞ : N•m (kg-m, in-lb)
- ☞ : N•m (kg-m, ft-lb)
- ☞ : Lubricate with new engine oil.

SEM311FA

GI

MA

EM

LC

EC

FE

CL

MT

AT

TF

PD

AX

SU

BR

ST

RS

BT

HA

SC

EL

IDX

TIMING BELT

Removal

NAEM0010

Removal

1. Remove engine under cover.
 2. Drain engine coolant from radiator.
- Be careful not to spill coolant on drive belts.**
3. Remove radiator. (Refer to LC section.)
 4. Remove engine cooling fan and water pump pulley.
 5. Remove the following belts.
 - Power steering pump drive belt
 - Compressor drive belt
 - Alternator drive belt
 6. Remove all spark plugs.
 7. Remove distributor protector.
 8. Remove compressor drive belt idler bracket.
 9. Remove fresh-air intake tube for rocker cover.
 10. Remove water hose for thermostat housing.

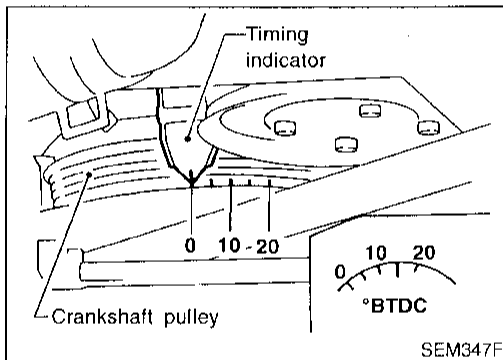

11. Set No. 1 piston at TDC on its compression stroke by rotating crankshaft.
12. Remove crankshaft pulley bolt.
13. Remove crankshaft pulley with a suitable puller.
14. Remove front upper and lower belt covers.

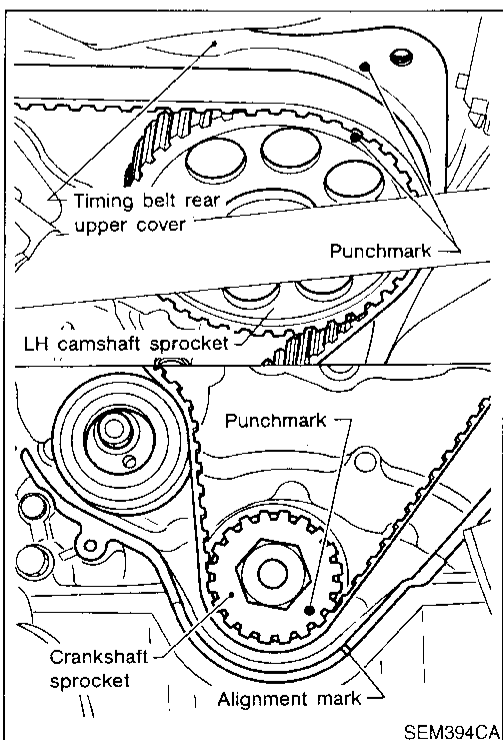

- Align punchmark on LH camshaft sprocket with punchmark on timing belt upper rear cover.
- Align punchmark on crankshaft sprocket with notch on oil pump housing.
- Temporarily install crank pulley bolt on crankshaft so that crankshaft can be rotated.

TIMING BELT

Removal (Cont'd)

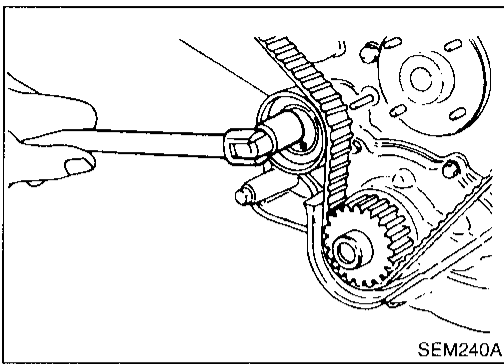

15. Loosen timing belt tensioner nut, turn tensioner, then remove timing belt.

GI

MA

EM

LC

EC

NAEM0011

FE

Inspection

Visually check the condition of timing belt.
Replace if any abnormality is found.

Item to check	Problem	Cause
<p>Tooth is broken/tooth root is cracked.</p>	<p>SEM394A</p>	<ul style="list-style-type: none"> ● Camshaft jamming ● Distributor jamming ● Damaged camshaft/crankshaft oil seal
<p>Back surface is cracked/worn.</p>	<p>SEM395A</p>	<ul style="list-style-type: none"> ● Tensioner jamming ● Overheated engine ● Interference with belt cover
<p>Side surface is worn.</p>	<p>SEM396A</p> <ul style="list-style-type: none"> ● Belt corners are worn and round. ● Wicks are frayed and coming out. 	<ul style="list-style-type: none"> ● Improper installation of belt ● Malfunctioning crankshaft pulley plate/timing belt plate
<p>Teeth are worn.</p>	<p>SEM397A</p> <ul style="list-style-type: none"> ● Canvas on tooth face is worn down. ● Canvas on tooth is fluffy, rubber layer is worn down and faded white, or weft is worn down and invisible. 	<ul style="list-style-type: none"> ● Poor belt cover sealing ● Coolant leakage at water pump ● Camshaft not functioning properly ● Distributor not functioning properly ● Excessive belt tension
<p>Oil/Coolant or water is stuck to belt.</p>	<p>—</p>	<ul style="list-style-type: none"> ● Poor oil sealing of each oil seal ● Coolant leakage at water pump ● Poor belt cover sealing

CL

MT

AT

TF

PD

AX

SU

BR

ST

RS

BT

HA

SC

EL

IDX

TIMING BELT

Inspection (Cont'd)

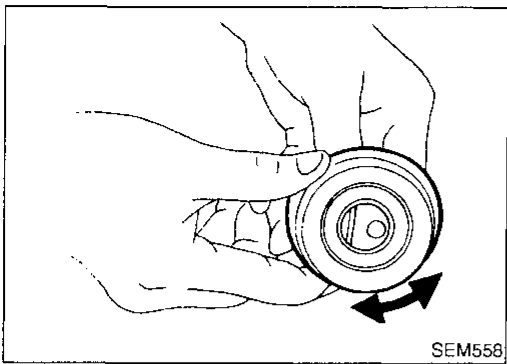

SEM558

BELT TENSIONER AND TENSIONER SPRING

NAEM001S01

1. Check belt tensioner for smooth turning.
2. Check condition of tensioner spring.

Installation

NAEM0012

1. Confirm that No. 1 piston is set at TDC on its compression stroke.

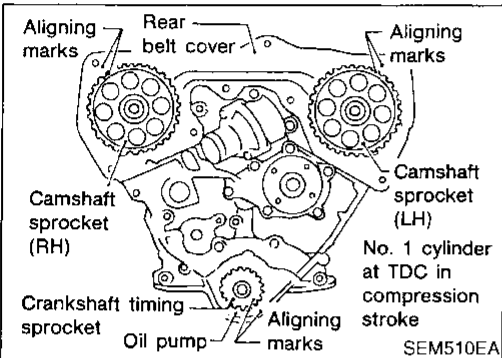

SEM510EA

2. Install tensioner and tensioner spring.

If stud is once removed, apply locking sealant to threads of stud on cylinder block side before installing.

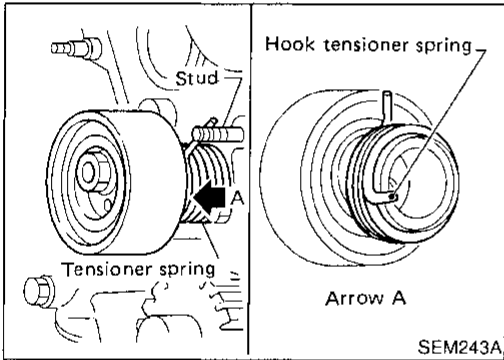

SEM243A

3. Turn tensioner fully outward with hexagon wrench, and temporarily tighten lock nut.

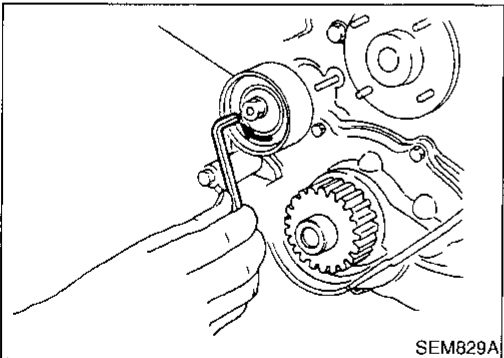

SEM829A

4. Set timing belt when engine is cold.

- 1) Align white lines on timing belt with punchmarks on camshaft sprockets and crankshaft sprocket.
- 2) Point arrow on timing belt toward front belt cover.

Number of teeth (reference):

Number of timing belt teeth		133
Number of teeth between timing marks	Between LH and RH camshaft sprockets	40
	Between LH camshaft sprocket and crankshaft timing sprocket	43

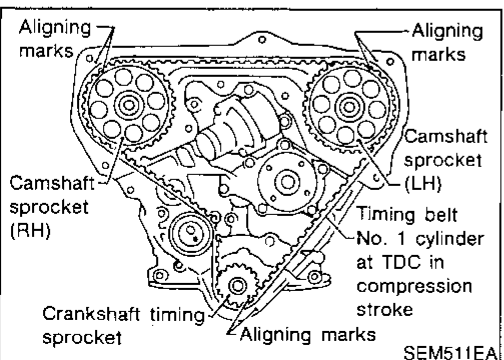

SEM511EA

TIMING BELT

Installation (Cont'd)

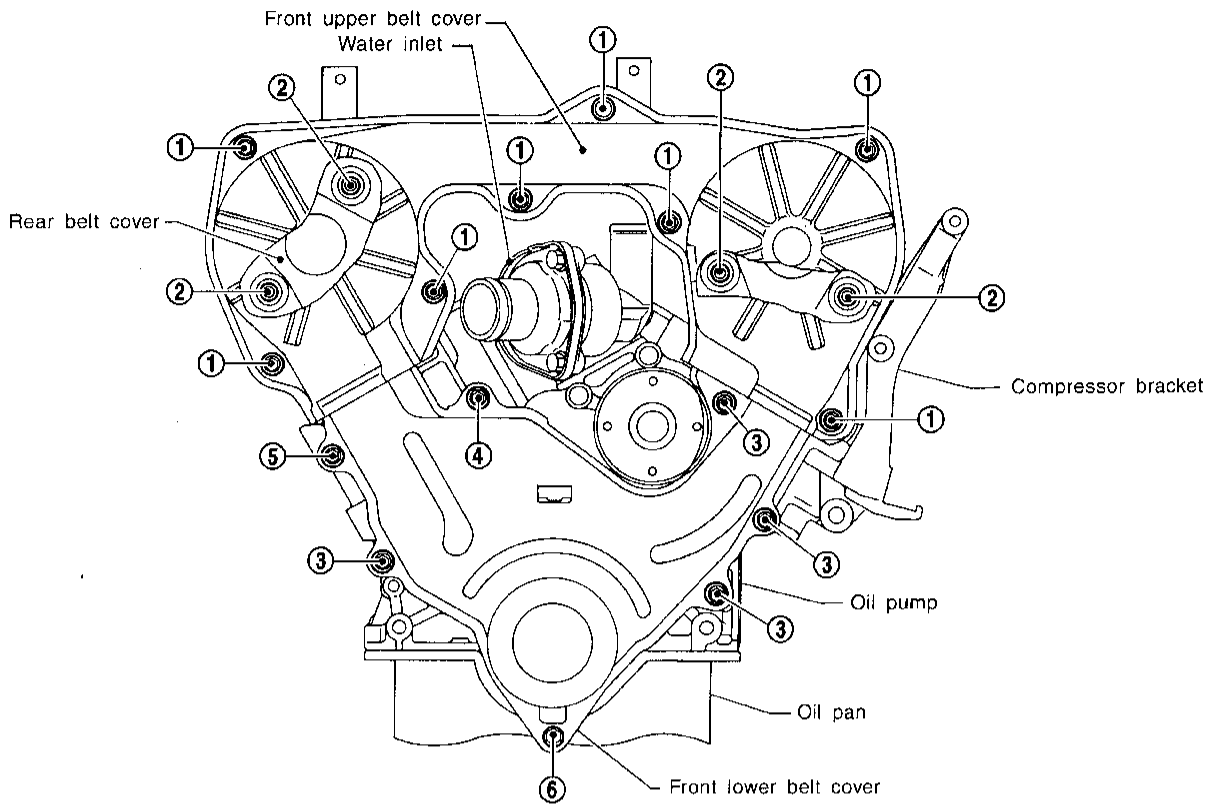

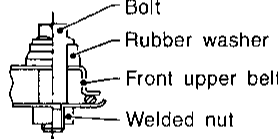
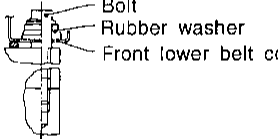
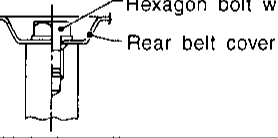
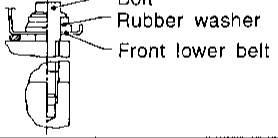
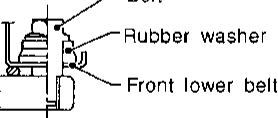
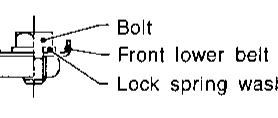
No.	Tightened parts	No.	Tightened parts		
①	 Bolt Rubber washer Front upper belt cover Welded nut	8 pcs.	④	 Bolt Rubber washer Front lower belt cover	1 pc.
②	 Hexagon bolt with washer Rear belt cover	4 pcs.	⑤	 Bolt Rubber washer Front lower belt cover	1 pc.
③	 Bolt Rubber washer Front lower belt cover	4 pcs.	⑥	 Bolt Front lower belt cover Lock spring washer	1 pc.

SEM313F

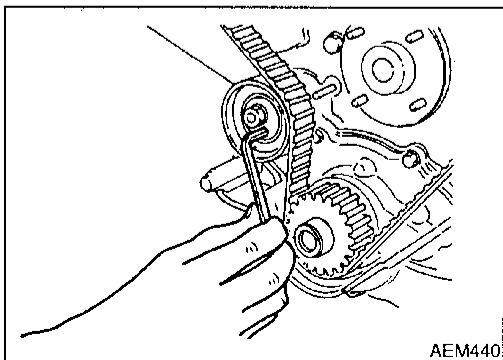

AEM440

Tension Adjustment AFTER BELT REPLACEMENT

If the timing belt was replaced (or to adjust tension on a used belt), follow the steps below.

1. Loosen tensioner lock nut, then turn tensioner clockwise and counterclockwise with hexagon wrench at least 2 times.

NAEM0040

NAEM0040S01

GI
MA
EM
LC
EC
FE
CL
MT
AT
TF
PD
AX
SU
BR
ST
RS
BT
HA
SC
EL
IDX

TIMING BELT

Tension Adjustment (Cont'd)

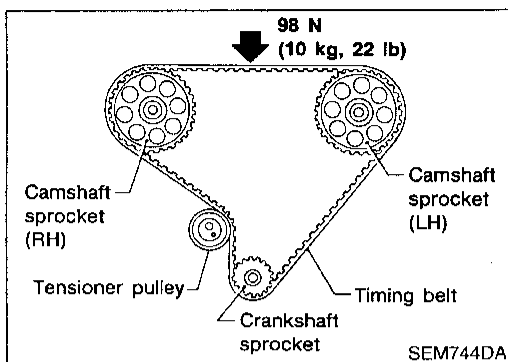

2. Tighten tensioner lock nut.
3. Turn crankshaft clockwise at least 2 times, then slowly set No. 1 piston at TDC on its compression stroke.
4. Measure deflection of timing belt midway between camshaft pulleys while pushing with 98 N (10 kg, 22 lb) force.

Belt deflection when engine is cold (Reference value):
13 - 15 mm (0.51 - 0.59 in)/98 N (10 kg, 22 lb)

5. If NG, return to step 1.

AFTER ENGINE OVERHAUL OR ENGINE REASSEMBLY (WITH ROCKER COVERS REMOVED)

NAEM0040S02

If the engine was overhauled or previously disassembled (i.e. intake manifold and/or cylinder head were removed), follow the steps below.

1. Loosen rocker shaft bolts to relieve belt tension caused by the cam shafts.

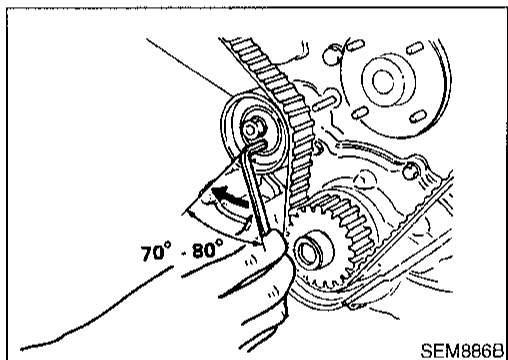

2. Loosen tensioner lock nut, keeping tensioner steady with hexagon wrench.
3. Turn tensioner 70 to 80 degrees clockwise with hexagon wrench to release belt tension, and temporarily tighten lock nut.
4. Turn crankshaft clockwise at least two times, then slowly set No. 1 piston at TDC on its compression stroke.

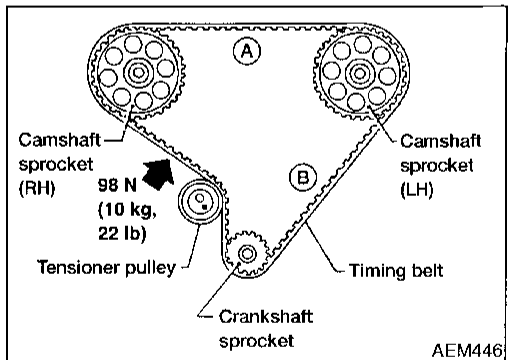

5. Push middle of timing belt between RH camshaft sprocket and tensioner pulley with force of 98 N (10 kg, 22 lb) to apply tensions on part A and part B.
6. Loosen tensioner lock nut, keeping tensioner steady with hexagon wrench.

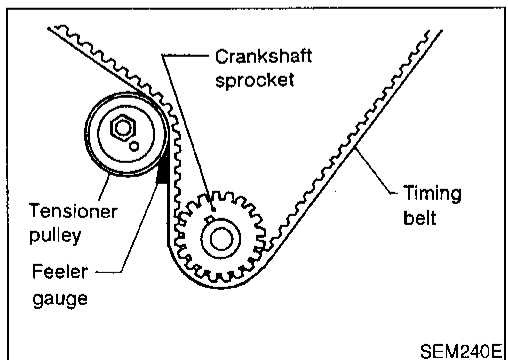

7. Set feeler gauge as shown in figure which is 0.5 mm (0.020 in) thick and 12.7 mm (0.500 in) wide.

TIMING BELT

Tension Adjustment (Cont'd)

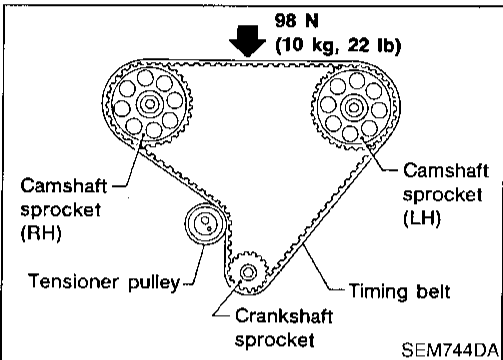
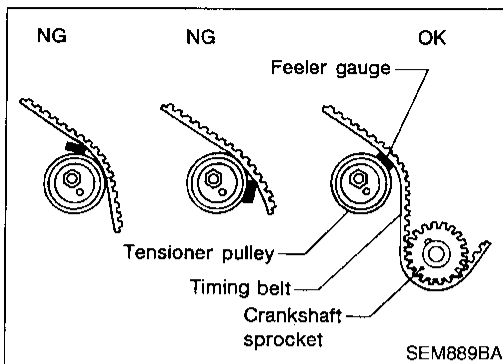

8. Turn crankshaft clockwise until feeler gauge is positioned as shown in figure.
 - Timing belt will move about 2.5 teeth.
9. Tighten tensioner lock nut, keeping tensioner steady with hexagon wrench.
10. Turn crankshaft clockwise or counterclockwise, and remove feeler gauge.
11. Turn crankshaft clockwise at least two times, then slowly set No. 1 piston at TDC on its compression stroke.
12. Measure deflection of timing belt midway between camshaft pulleys while pushing with 98 N (10 kg, 22 lb) force.

Belt deflection when engine is cold (Reference value):
13 - 15 mm (0.51 - 0.59 in)/98 N (10 kg, 22 lb)
13. If NG, return to step 1.
14. Install lower and upper belt covers.

GI

MA

EM

LC

EC

FE

CL

MT

AT

TF

PD

AX

SU

BR

ST

RS

BT

HA

SC

EL

IDX

OIL SEAL

Replacement

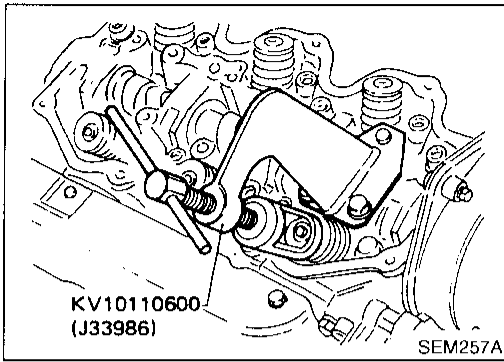

Replacement VALVE OIL SEAL

NAEM0013

NAEM0013S01

1. Remove rocker cover.
2. Remove rocker shaft assembly and valve lifters with valve lifter guide.
3. Remove valve springs and valve oil seal.
 - Piston concerned should be set at TDC to prevent valve from falling.
 - When removing intake side valve oil seal, use Tool or suitable tool.
 - When removing exhaust side valve oil seal, pull it out with suitable tool.

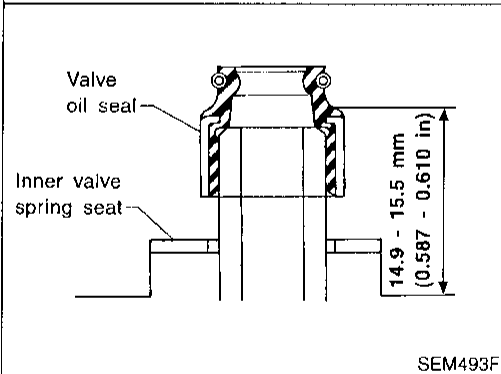
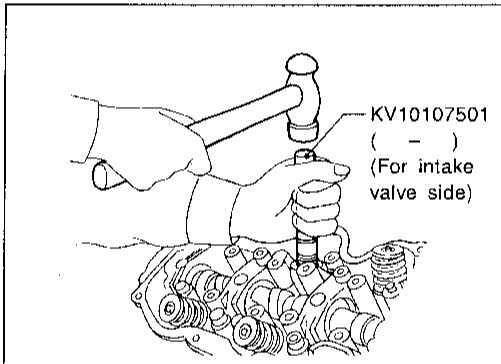

4. Apply engine oil to new valve oil seal and install it.
 - Before installing valve oil seal, install inner valve spring seat.
 - When installing intake side valve oil seal, use Tool.
 - When installing exhaust side valve oil seal, set it by hand.

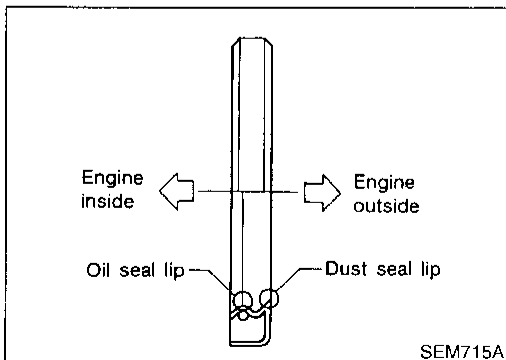

OIL SEAL INSTALLING DIRECTION

NAEM0013S02

OIL SEAL

Replacement (Cont'd)

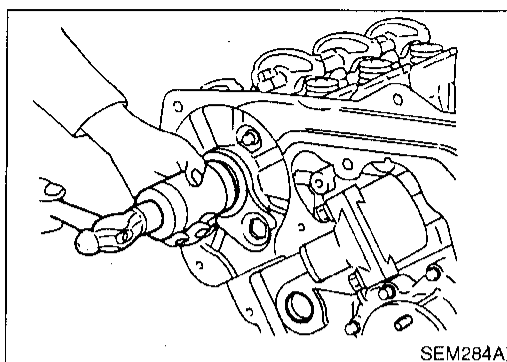

CAMSHAFT OIL SEAL

NAEM0013S03

1. Remove timing belt.
 2. Remove camshaft sprocket.
 3. Remove camshaft.
 4. Remove camshaft oil seal.
- Be careful not to scratch camshaft.**
5. Apply engine oil to new camshaft oil seal.

GI

MA

EM

LC

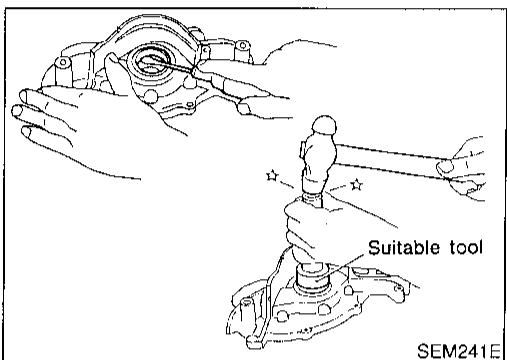

FRONT OIL SEAL

NAEM0013S04

1. Remove timing belt and crankshaft sprocket.
2. Remove oil pump assembly.
3. Remove front oil seal from oil pump body.
4. Apply engine oil to new oil seal and install it using suitable tool.

EC

FE

CL

MT

AT

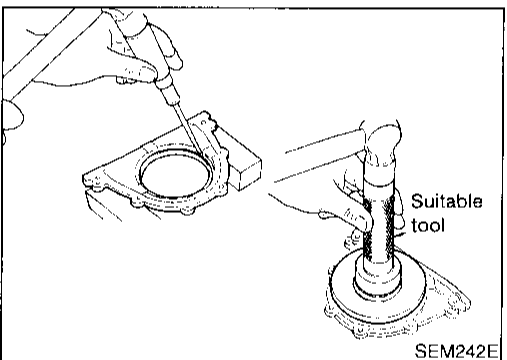

REAR OIL SEAL

NAEM0013S05

1. Remove flywheel or drive plate.
2. Remove rear oil seal retainer.
3. Remove rear oil seal from retainer.
4. Apply engine oil to new oil seal and install it using suitable tool.
5. Install rear oil seal retainer with a new gasket to cylinder block.

TF

PD

AX

SU

BR

ST

RS

BT

HA

SC

EL

IDX

CYLINDER HEAD

Components

Components

NAEM0014

SEC. 102•111•130

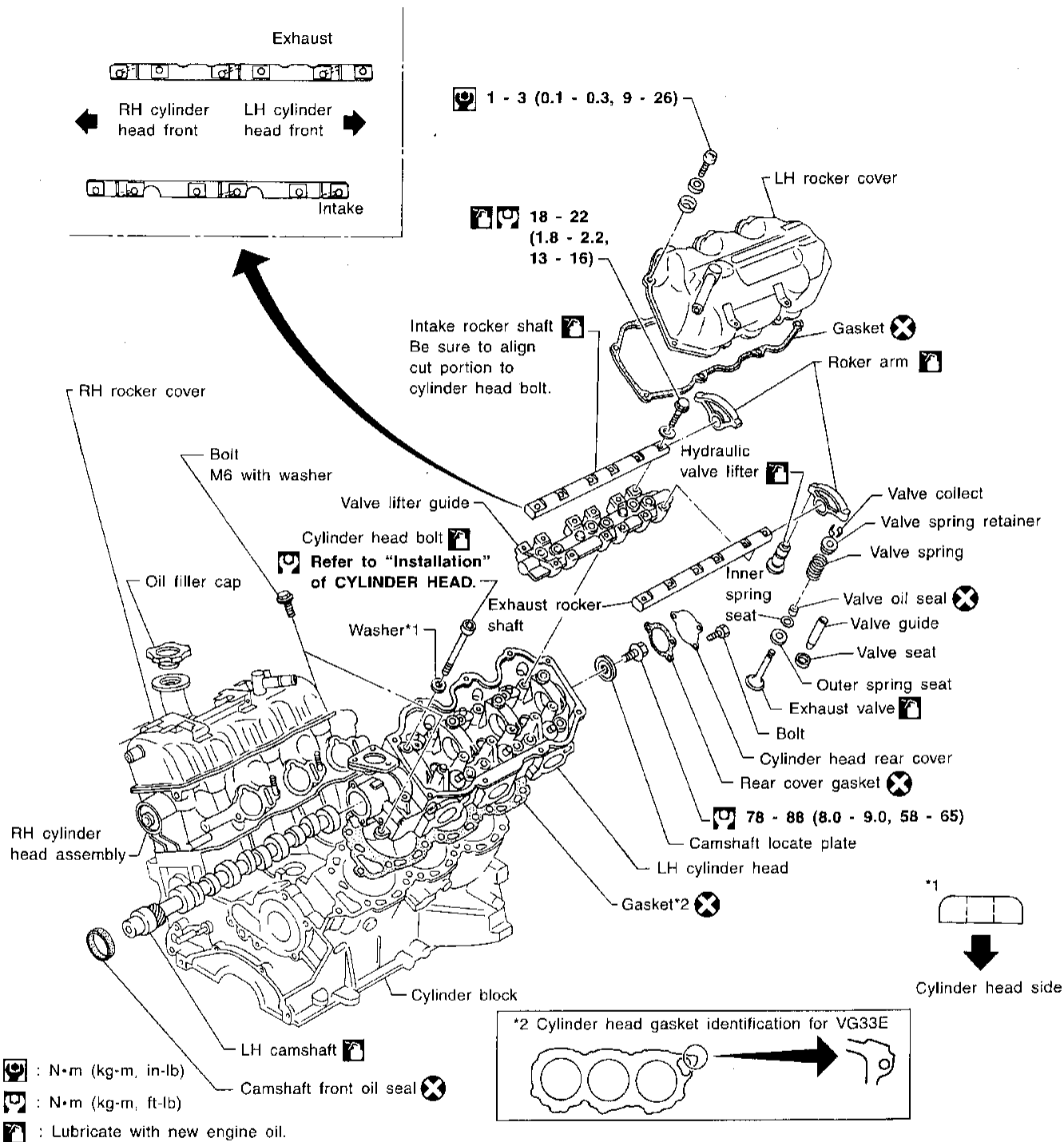

Removal

GI
NAEM0015

1. Release fuel pressure.
Refer to "Releasing Fuel Pressure" in EC section.
2. Remove timing belt.
Refer to "TIMING BELT — Removal" (EM-18).

MA

EM

LC

EC

FE

CL

MT

AT

TF

PD

AX

SU

BR

ST

BS

BT

HA

SC

EL

DX

DX

3. Drain coolant by removing drain plugs from both sides of cylinder block.

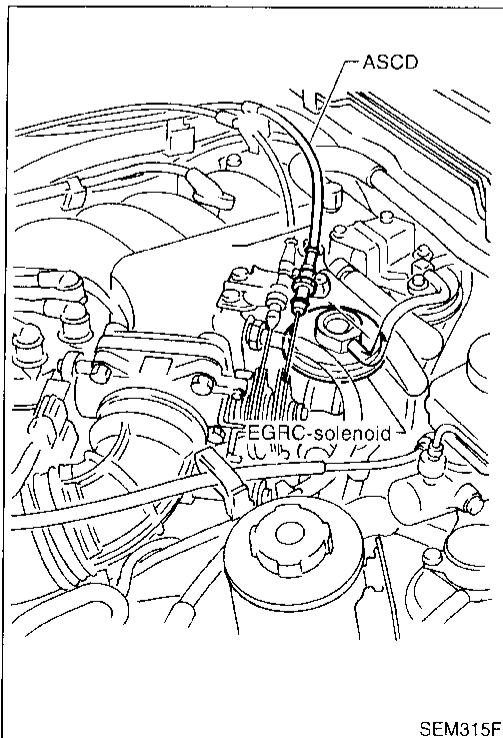
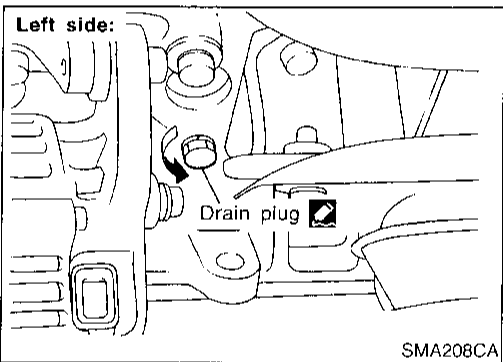
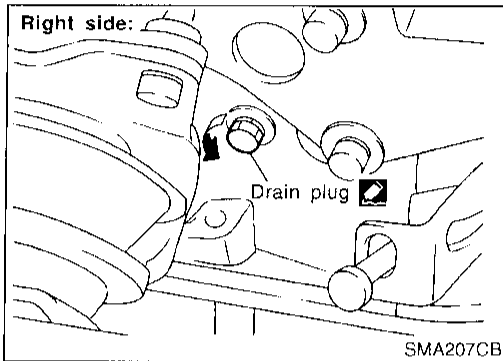

4. Separate ASCD and accelerator control wire from intake manifold collector.
5. Remove intake manifold collector from engine. The following parts should be disconnected to remove intake manifold collector.
 - a. Harness connectors for: IACV-AAC valve, Throttle position sensor, Throttle position switch, Ignition coil, Power transistor, EGRC-solenoid valve, and EGR temperature sensor.
 - b. Water hoses from collector
 - c. Heater hoses
 - d. PCV hose from RH rocker cover
 - e. Vacuum hoses for: EVAP canister, Master brake cylinder and Pressure regulator.
 - f. Purge hose from EVAP canister
 - g. EGR tube
 - h. Earth harnesses
 - i. Air duct hose

CYLINDER HEAD

Removal (Cont'd)

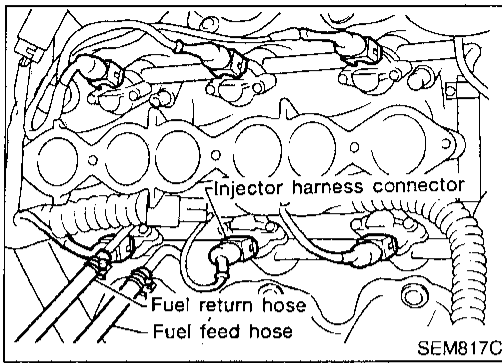

6. Remove fuel feed and fuel return hoses from injector fuel tube assembly.
7. Disconnect all injector harness connectors.
8. Remove injector fuel tube assembly.

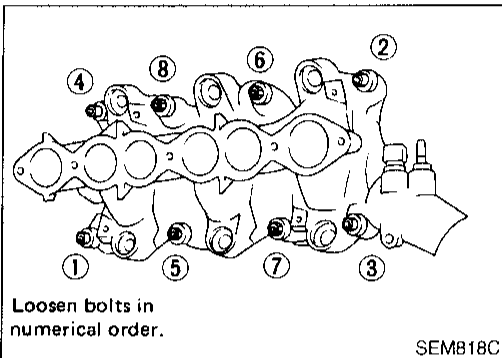

9. Remove intake manifold from engine. The following parts should be disconnected to remove intake manifold.
 - a. Engine coolant temperature switch harness connector
 - b. Thermal transmitter harness connector
 - c. Water hose from thermostat housing

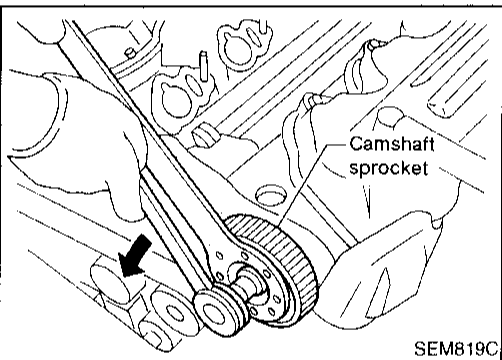

10. Remove both camshaft sprockets.
 11. Remove rear timing belt cover.
 12. Remove distributor and ignition wires.
- After pulling out distributor from cylinder head, do not rotate distributor rotor.**
13. Remove harness clamp from RH rocker cover.
 14. Remove front exhaust tube from exhaust manifold.

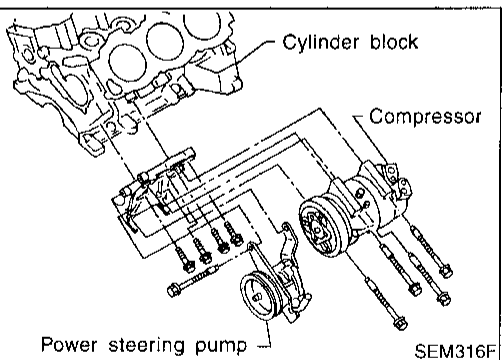

15. Remove compressor and power steering pump.
16. Remove alternator.
17. Remove compressor and alternator bracket.

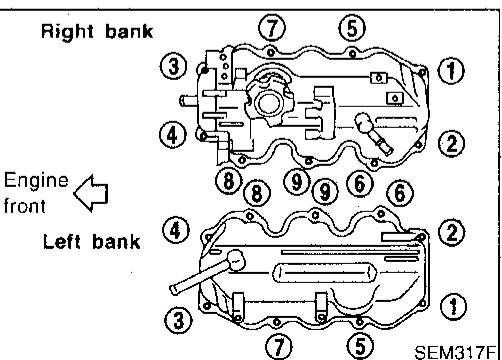

18. Remove both rocker covers.

CYLINDER HEAD

Removal (Cont'd)

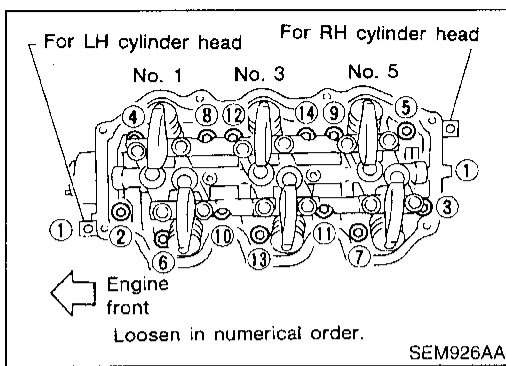

19. Remove cylinder head with exhaust manifold.

- A warped or cracked cylinder head could result from removing in incorrect order.
- Cylinder head bolts should be loosened in two or three steps.

Disassembly

CAUTION:

- When installing sliding parts such as rocker arms, camshaft and oil seal, be sure to apply new engine oil on their sliding surfaces.
- When tightening cylinder head bolts and rocker shaft bolts, apply new engine oil to thread portions and seat surfaces of bolts.

NAEM0016

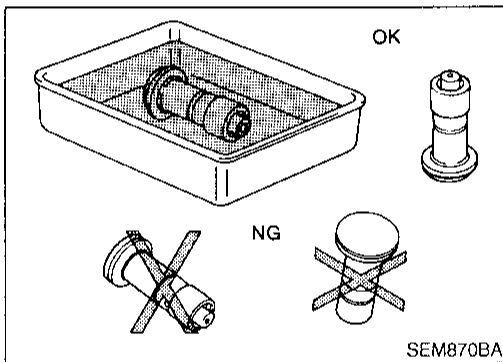

- If hydraulic valve lifter is kept on its side, there is a risk of air entering it. After removal, always set hydraulic valve lifter straight up, or when laying it on its side, have it soak in new engine oil.
- Do not disassemble hydraulic valve lifter.
- Attach tags to valve lifters so as not to mix them up.

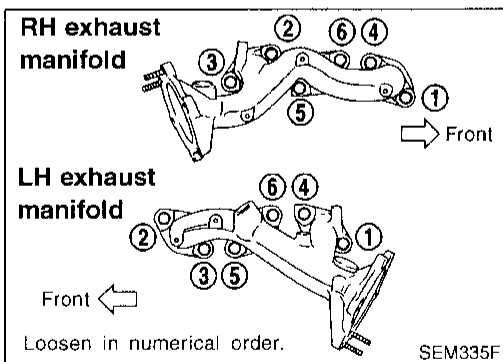

1. Remove exhaust manifolds from cylinder head.

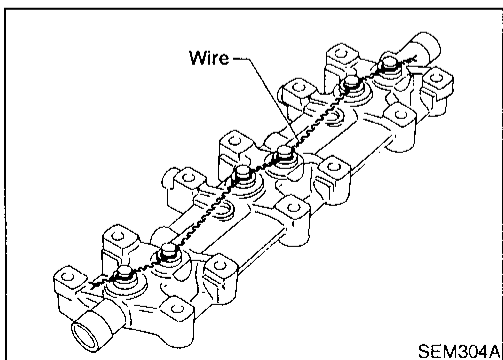

2. Remove rocker shafts with rocker arms.

Bolts should be loosened in two or three steps.

3. Remove hydraulic valve lifters and lifter guide.

- Hold hydraulic valve lifters with wire so that they will not drop from lifter guide.

4. Remove oil seal and camshaft.

- Before removing camshaft, measure camshaft end play.

GI

MA

EM

LC

EC

FE

CL

MT

AT

TF

PD

AX

SU

BR

ST

RS

BT

HA

SC

EL

IDX

CYLINDER HEAD

Disassembly (Cont'd)

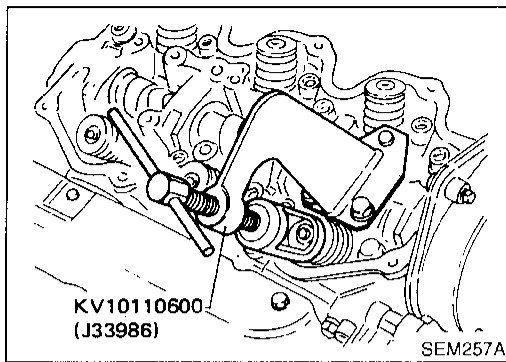

5. Remove valve components with Tool.
6. Remove valve oil seals with Tool or suitable tool.

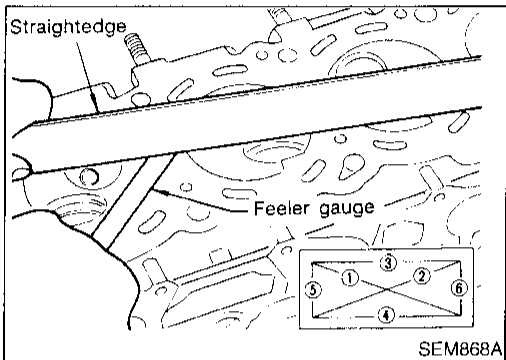

Inspection

CYLINDER HEAD DISTORTION

Head surface flatness:

Less than 0.1 mm (0.004 in)

If beyond the specified limit, resurface it or replace it.

Resurfacing limit:

The resurfacing limit of cylinder head is determined by the cylinder block resurfacing in an engine.

Amount of cylinder head resurfacing is "A".

Amount of cylinder block resurfacing is "B".

The maximum limit is as follows:

$A + B = 0.2 \text{ mm (0.008 in)}$

After resurfacing cylinder head, check that camshaft rotates freely by hand. If resistance is felt, cylinder head must be replaced.

Nominal cylinder head height:

106.8 - 107.2 mm (4.205 - 4.220 in)

CAMSHAFT VISUAL CHECK

Check camshaft for scratches, seizure and wear.

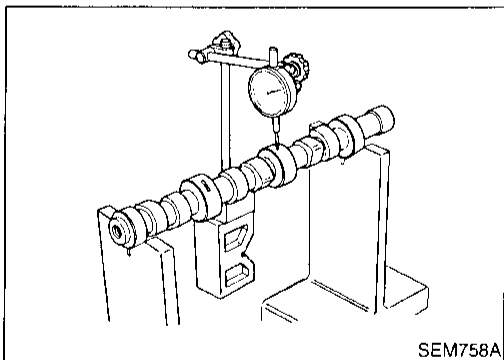

CAMSHAFT RUNOUT

1. Measure camshaft runout at the center journal.

Runout (Total indicator reading):

Limit 0.1 mm (0.004 in)

2. If it exceeds the limit, replace camshaft.

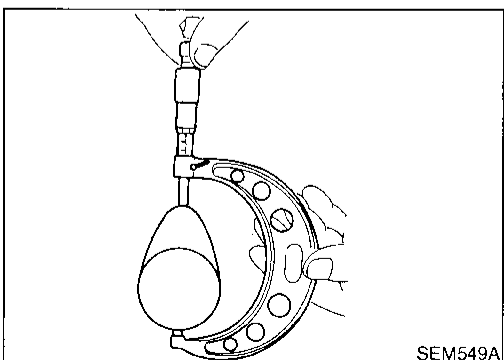

CAMSHAFT CAM HEIGHT

1. Measure camshaft cam height.

Standard cam height:

Intake: 38.943 - 39.133 mm (1.5332 - 1.5407 in)

Exhaust: 38.943 - 39.133 mm (1.5332 - 1.5407 in)

Cam wear limit:

0.15 mm (0.0059 in)

2. If wear is beyond the limit, replace camshaft.

CAMSHAFT JOURNAL CLEARANCE

NAEM001/505

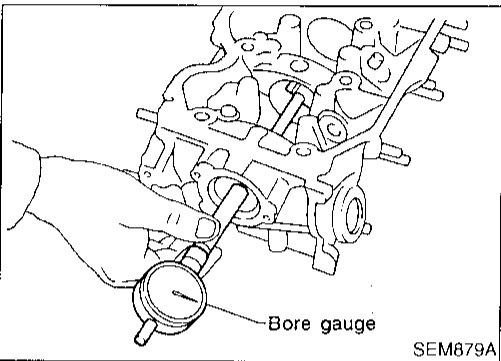
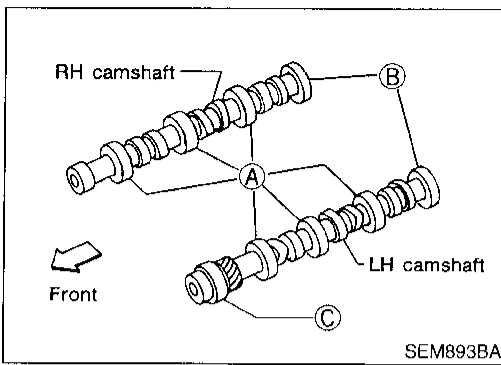

1. Measure inner diameter of camshaft bearing.
Standard inner diameter:
A 47.000 - 47.025 mm (1.8504 - 1.8514 in)
B 42.500 - 42.525 mm (1.6732 - 1.6742 in)
C 48.000 - 48.025 mm (1.8898 - 1.8907 in)

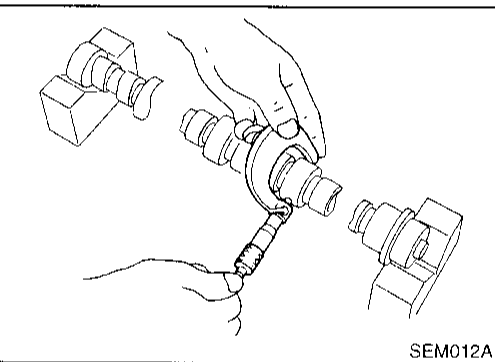

2. Measure outer diameter of camshaft journal.
Standard outer diameter:
A 46.920 - 46.940 mm (1.8472 - 1.8480 in)
B 42.420 - 42.440 mm (1.6701 - 1.6709 in)
C 47.920 - 47.940 mm (1.8866 - 1.8874 in)
3. If clearance exceeds the limit, replace camshaft and/or cylinder head.
Camshaft journal clearance limit:
0.15 mm (0.0059 in)

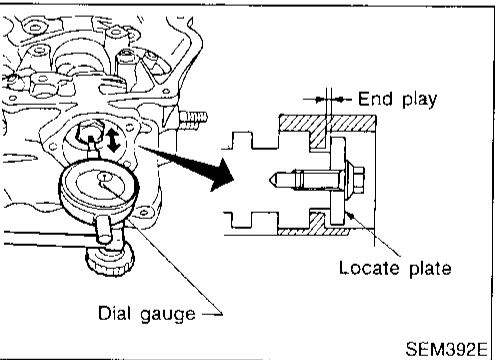

CAMSHAFT END PLAY

NAEM0017506

1. Install camshaft and locate plate in cylinder head.
2. Measure camshaft end play.
Camshaft end play:
Standard 0.03 - 0.06 mm (0.0012 - 0.0024 in)

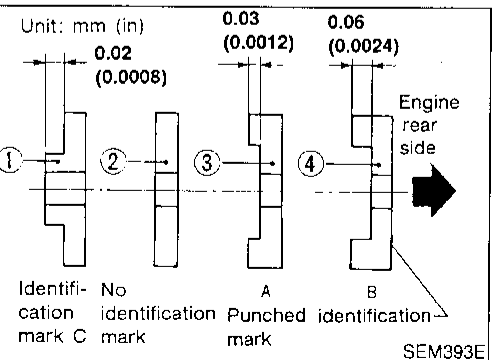

3. If it is out of the specified range, select thickness of camshaft locate plate to obtain standard specified end play.
Example:
 When camshaft end play is 0.08 mm (0.0031 in) with camshaft locate plate 2, replace camshaft locate plate 2 with camshaft locate plate 3 to set the end play at 0.05 mm (0.0020 in).

CYLINDER HEAD

Inspection (Cont'd)

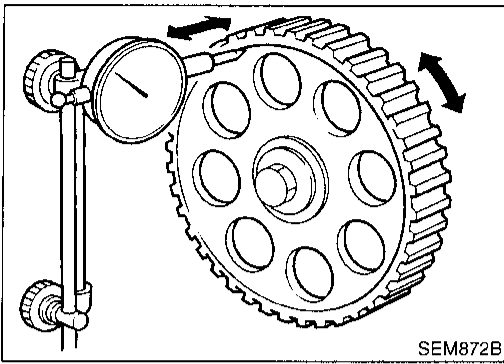

CAMSHAFT SPROCKET RUNOUT

NAEM0017S07

1. Install sprocket on camshaft.
2. Measure camshaft sprocket runout.
Runout (Total indicator reading):
Limit 0.1 mm (0.004 in)
3. If it exceeds the limit, replace camshaft sprocket.

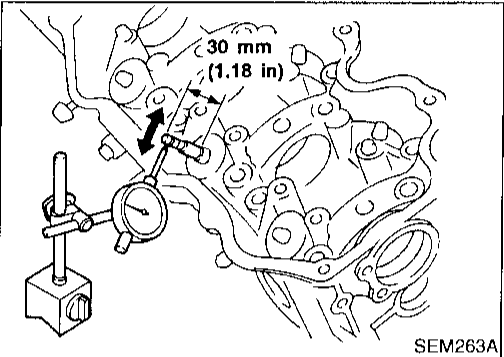

VALVE GUIDE CLEARANCE

NAEM0017S08

1. Measure valve deflection in a right-angled direction with camshaft. (Valve and valve guide mostly wear in this direction.)
Valve deflection limit (Dial gauge reading):
0.20 mm (0.0079 in)

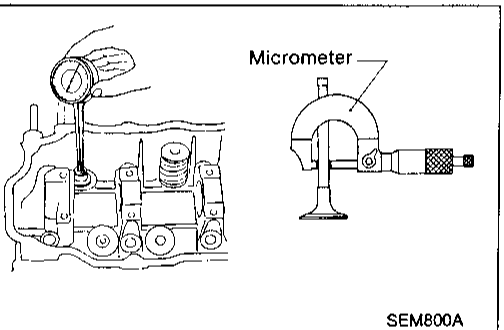

2. If it exceeds the limit, check valve to valve guide clearance.
 - a. Measure valve stem diameter and valve guide inner diameter.
 - b. Check that clearance is within specification.

Valve to valve guide clearance:

Intake

0.020 - 0.053 mm (0.0008 - 0.0021 in)

Exhaust

0.040 - 0.049 mm (0.0016 - 0.0019 in)

Limit

0.10 mm (0.0039 in)

- c. If it exceeds the limit, replace valve or valve guide.

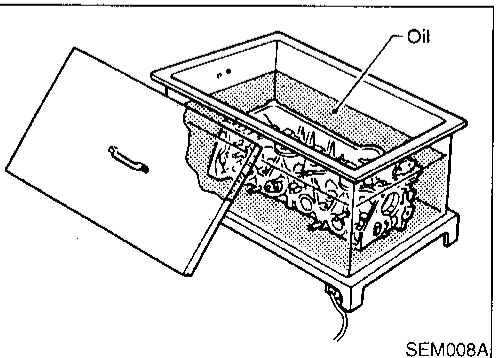
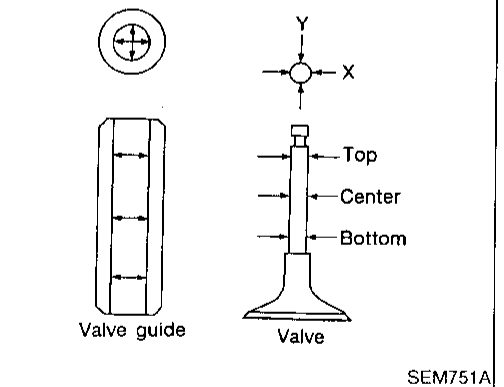

VALVE GUIDE REPLACEMENT

NAEM0017S09

1. To remove valve guide, heat cylinder head to 150 to 160°C (302 to 320°F) by soaking in heated oil.

CYLINDER HEAD

Inspection (Cont'd)

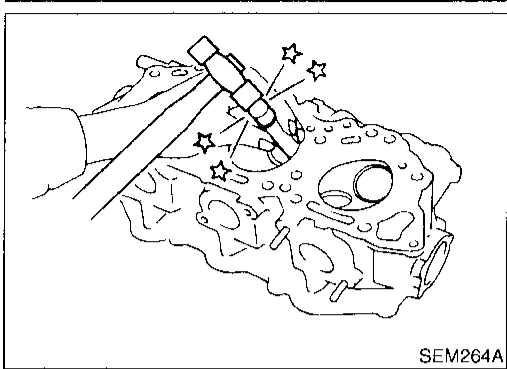

- Drive out valve guide with a press [under a 20 kN (2 ton, 2.2 US ton, 2.0 Imp ton) pressure] or hammer and suitable tool.

GJ

MA

EM

LC

EC

FE

CL

MT

AT

TF

PD

AX

SU

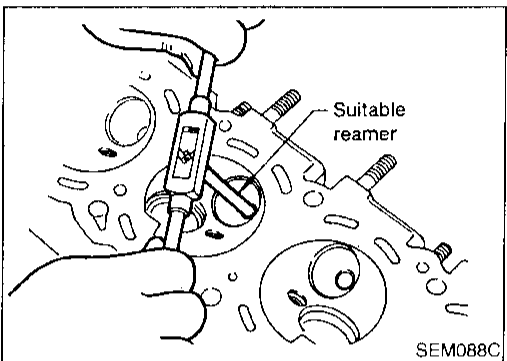

- Ream cylinder head valve guide hole.
Valve guide hole diameter (for service parts):

Intake
 11.175 - 11.196 mm (0.4400 - 0.4408 in)
Exhaust
 12.175 - 12.196 mm (0.4793 - 0.4802 in)

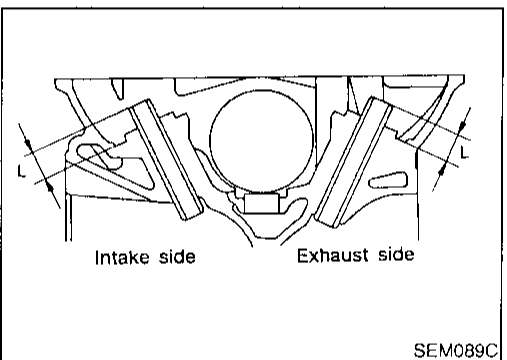

- Heat cylinder head to 150 to 160°C (302 to 320°F) and press service valve guide onto cylinder head.

Projection "L":
 13.2 - 13.4 mm (0.520 - 0.528 in)

- Ream valve guide.

Finished size:
Intake
 7.000 - 7.018 mm (0.2756 - 0.2763 in)
Exhaust
 8.000 - 8.011 mm (0.3150 - 0.3154 in)

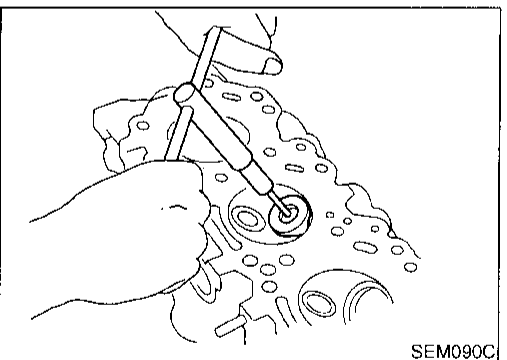

VALVE SEATS

NAEM0017510

Check valve seats for any evidence of pitting at valve contact surface, and reseat or replace if it has worn out excessively.

- Before repairing valve seats, check valve and valve guide for wear. If they have worn, replace them. Then correct valve seat.
- Use both hands to cut uniformly.

BR

ST

RS

BT

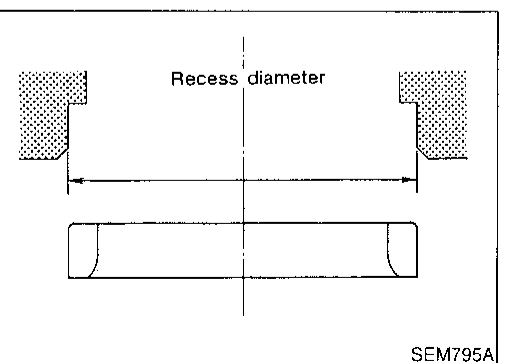

REPLACING VALVE SEAT FOR SERVICE PARTS

NAEM0017511

- Bore out old seat until it collapses. The machine depth stop should be set so that boring cannot continue beyond the bottom face of the seat recess in cylinder head.
- Ream cylinder head recess.

Reaming bore for service valve seat
Oversize [0.5 mm (0.020 in)]:

Intake
 44.500 - 44.516 mm (1.7520 - 1.7526 in)
Exhaust

HA

SC

EL

IDX

CYLINDER HEAD

Inspection (Cont'd)

37.500 - 37.516 mm (1.4764 - 1.4770 in)

Reaming should be done in circles concentric to the valve guide center so that valve seat will have the correct fit.

3. Heat cylinder head to 150 to 160°C (302 to 320°F) by soaking in heated oil.
4. Press fit valve seat until it seats on the bottom.

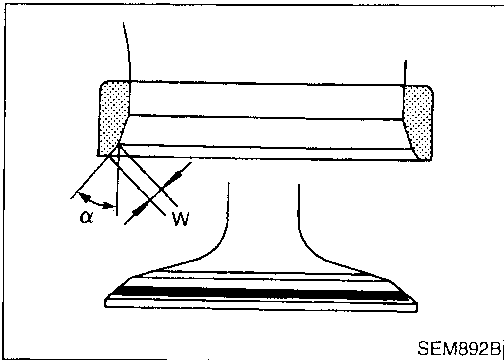

5. Cut or grind valve seat using suitable tool at the specified dimensions as shown in SDS (EM-58).
6. After cutting, lap valve seat with abrasive compound.
7. Check valve seating condition.

	Intake	Exhaust
Seat face angle " α " degree	45	45
Contacting width " W " mm (in)	1.75 (0.0689)	1.7 (0.067)

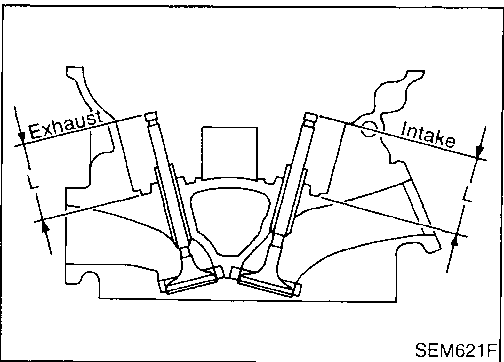

8. Use a depth gauge to measure the distance between the mounting surface of the cylinder head spring seat and the valve stem end. If the distance is shorter than specified, repeat step 5 above to adjust it. If it is longer, replace the valve seat with a new one.

Intake:

44.7 - 44.9 mm (1.760 - 1.768 in)

Exhaust:

45.4 - 45.6 mm (1.787 - 1.795 in)

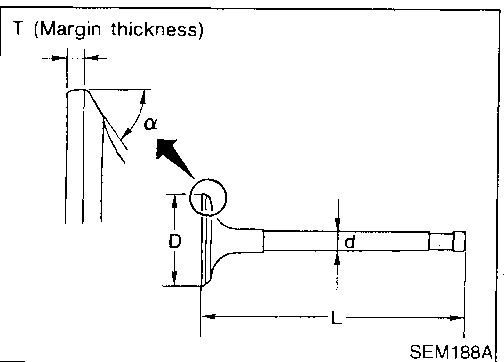

VALVE DIMENSIONS

Check dimensions in each valve. For dimensions, refer to SDS. When valve head has been worn down to 0.5 mm (0.020 in) in margin thickness, replace valve.

Grinding allowance for valve stem tip is 0.2 mm (0.008 in) or less.

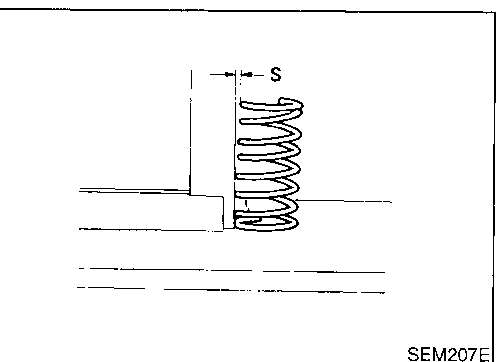

VALVE SPRING

Squareness

1. Measure " S " dimension.
Less than 2.2 mm (0.087 in)
2. If it exceeds the limit, replace spring.

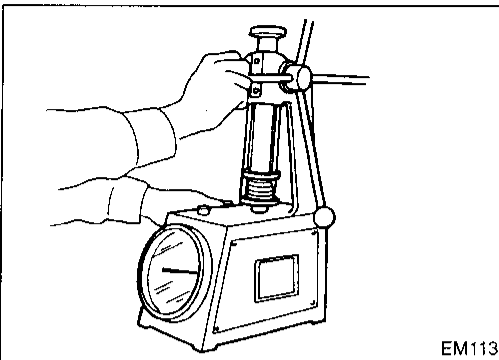

Pressure

Check valve spring pressure.

Standard pressure:

790 N (80.6 kg, 178 lb) at 30.0 mm (1.181 in)

Limit pressure:

More than 733 N (74.7 kg, 165 lb) at 30.0 mm (1.181 in)

If it exceeds the limit, replace spring.

NAEM0017S1302

GI

MA

EM

LC

EC

NAEM0017S14

ROCKER SHAFT AND ROCKER ARM

1. Check rocker shafts for scratches, seizure and wear.
2. Check outer diameter of rocker shaft.

Diameter:

17.979 - 18.000 mm (0.7078 - 0.7087 in)

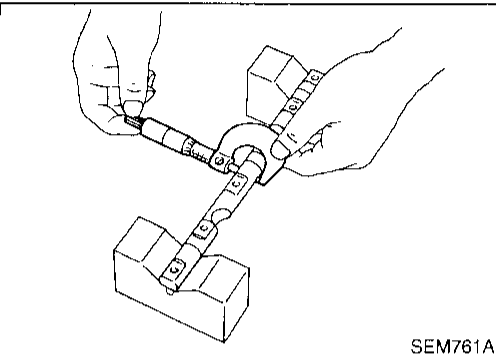

FE

CL

MT

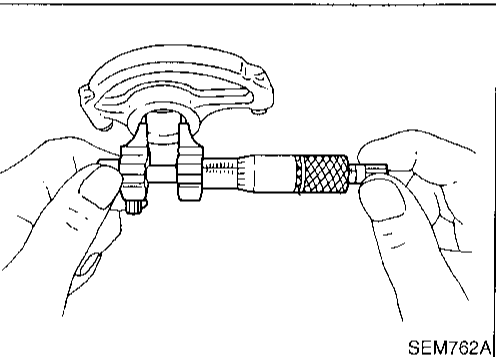

3. Check inner diameter of rocker arm.

Diameter:

18.007 - 18.028 mm (0.7089 - 0.7098 in)

Rocker arm to shaft clearance:

0.007 - 0.049 mm (0.0003 - 0.0019 in)

- Keep rocker arm with hydraulic valve lifter standing to prevent air from entering hydraulic valve lifter when checking.

AT

TF

PD

AX

SU

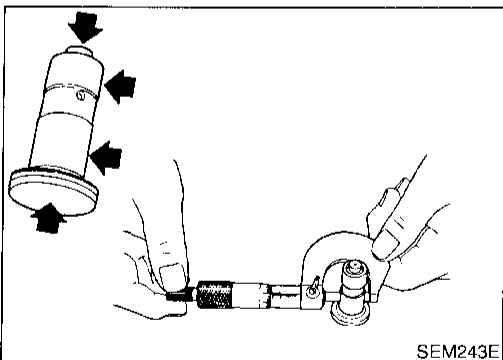

HYDRAULIC VALVE LIFTER

1. Check contact and sliding surfaces for wear or scratches.
2. Check diameter of valve lifter.

Outer diameter:

15.947 - 15.957 mm (0.6278 - 0.6282 in)

NAEM0017S15

BR

ST

RS

BT

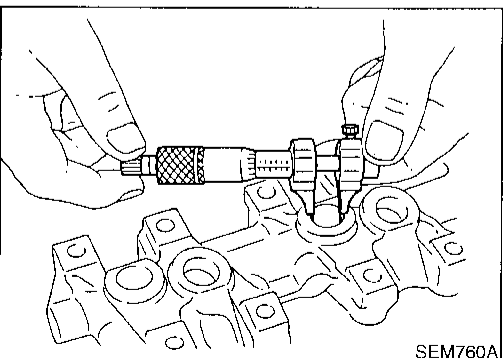

3. Check valve lifter guide inner diameter.

Inner diameter:

16.000 - 16.013 mm (0.6299 - 0.6304 in)

Standard clearance between valve lifter and lifter guide:

0.043 - 0.066 mm (0.0017 - 0.0026 in)

HA

SC

EL

IDX

CYLINDER HEAD

Assembly

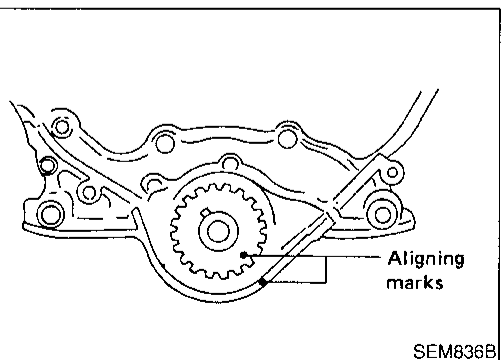
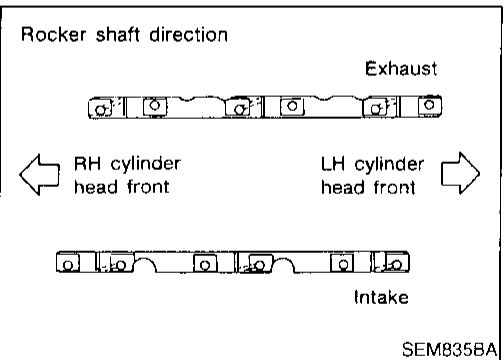
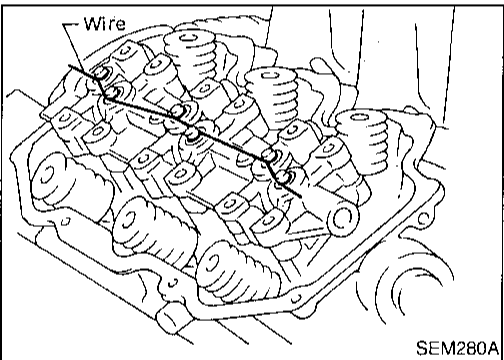
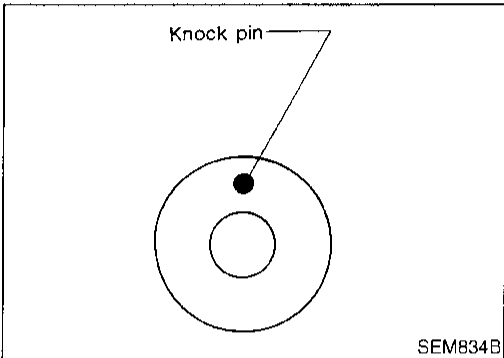
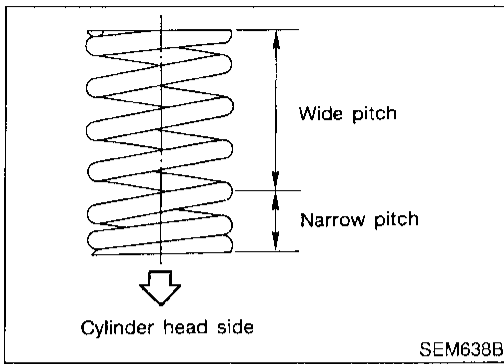

Assembly

NAEM001B

1. Install valve component parts.
 - Always use new valve oil seal. Refer to OIL SEAL REPLACEMENT (EM-24).
 - Before installing valve oil seal, install inner valve spring seat.
 - Install outer valve spring (uneven pitch type) with its narrow pitch side toward cylinder head side.
 - After installing valve component parts, use plastic hammer to lightly tap valve stem tip to assure a proper fit.
2. Install camshafts, locate plates and cylinder head rear covers.
 - Set knock pin of camshaft at the top.

3. Install valve lifters into valve lifter guide.
 - Assemble valve lifters to their original position and hold all valve lifters with wire to prevent lifters from falling off.
 - After installing, remove the wire.
4. Install rocker shafts with rocker arms.
 - Tighten bolts gradually in two or three stages.
 - Before tightening, be sure to set camshaft the lobe at the position where lobe is not lifted.
 - a. Set No. 1 piston at TDC on its compression stroke and tighten rocker shaft bolts for No. 2, No. 4 and No. 6 cylinders.
 - b. Set No. 4 piston at TDC on its compression stroke and tighten rocker shaft bolts for No. 1, No. 3 and No. 5 cylinders.
5. Install exhaust manifold to cylinder head in reverse order of removal.

Installation

NAEM001B

1. Set No. 1 piston at TDC on its compression stroke as follows:
 - a. Align crankshaft sprocket aligning mark with mark on oil pump body.
 - b. Confirm that knock pin on camshaft is set at the top.

CYLINDER HEAD

Installation (Cont'd)

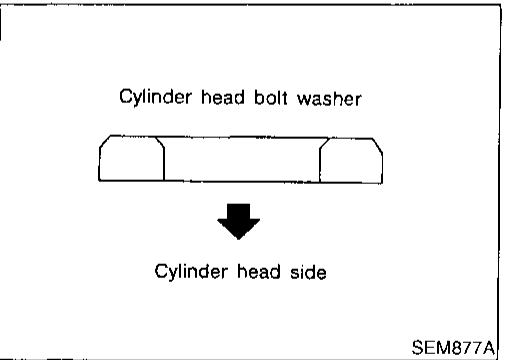
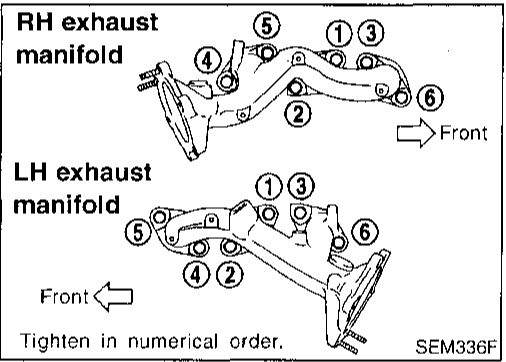
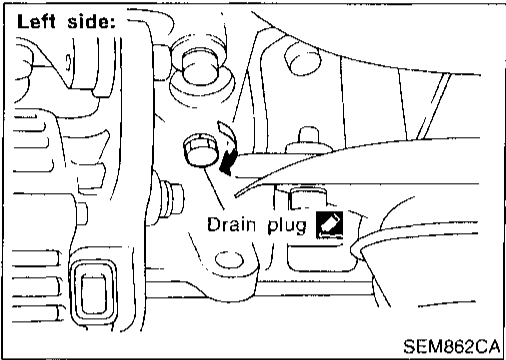
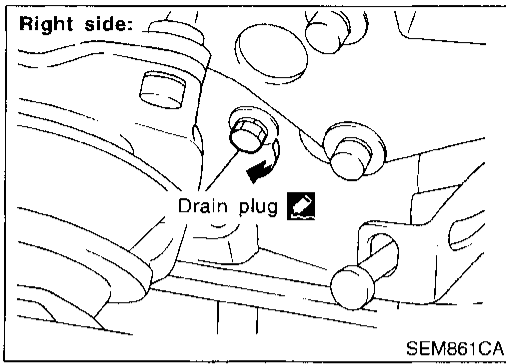

2. Install both drain plugs.
 - Use Genuine RTV silicone sealant Part No. 999MP-A7007 or equivalent.

3. Install exhaust manifolds to cylinder head.

4. Install cylinder head with new gasket.
 - Be sure to install washers between bolts and cylinder head.
 - Do not rotate crankshaft and camshaft separately, or valves will hit piston heads.

GI

MA

EM

LC

EC

FE

CL

MT

AT

TF

PD

AX

SU

BR

ST

RS

BT

HA

SC

EL

IDX

CYLINDER HEAD

Installation (Cont'd)

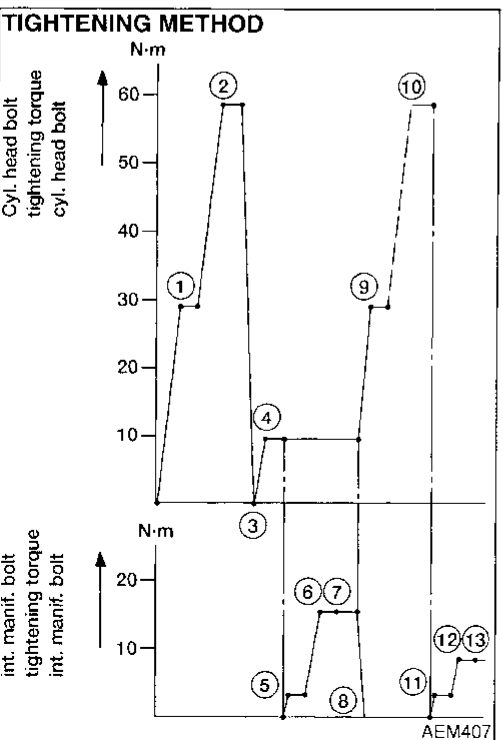
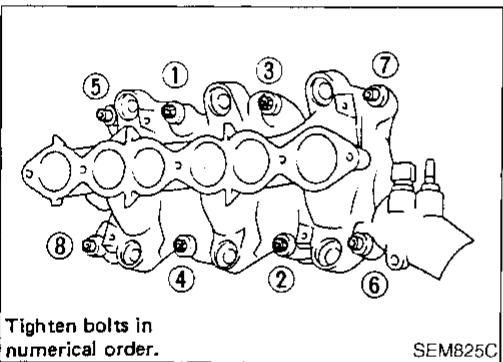
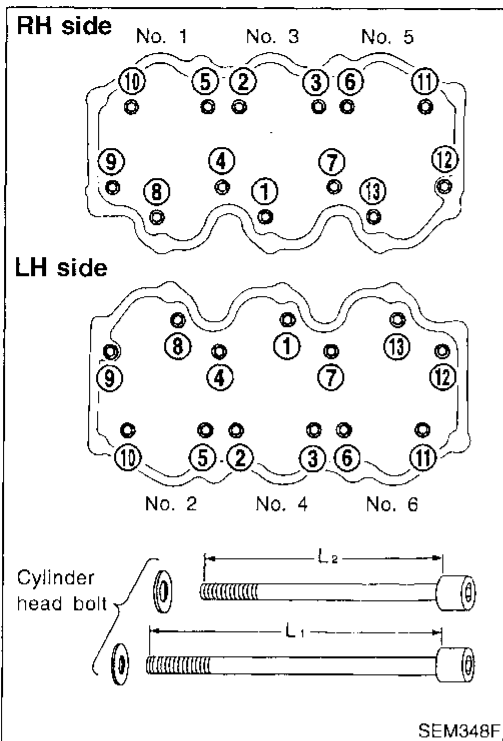

5. Tighten cylinder head bolts in numerical order using angle wrench [ST10120000 (J24239-01)].

Apply engine oil to threads and seating surfaces of cylinder head bolts before installing them.

- Cylinder head bolts for 4, 7, 9 and 12 are longer than the others.

L₁: 127 mm (5.00 in) for 4, 7, 9 and 12

L₂: 106 mm (4.17 in) for others

- Install intake manifold and cylinder head at the same time using the following procedure:

- 1) Tighten cylinder head bolts to 29 N·m (3.0 kg·m, 22 ft·lb).
- 2) Tighten cylinder head bolts to 59 N·m (6.0 kg·m, 43 ft·lb).
- 3) Loosen cylinder head bolts completely.
- 4) Tighten cylinder head bolts to 10 N·m (1.0 kg·m, 7 ft·lb).
- 5) Tighten intake manifold bolts and nuts to 4 N·m (0.4 kg·m, 2.9 ft·lb).
- 6) Tighten intake manifold bolts and nuts to 18 N·m (1.8 kg·m, 13 ft·lb).
- 7) Tighten intake manifold bolts and nuts to 16 to 20 N·m (1.6 to 2.0 kg·m, 12 to 14 ft·lb).
- 8) Loosen intake manifold bolts and nuts completely.
- 9) Tighten cylinder head bolts to 29 N·m (3.0 kg·m, 22 ft·lb).
- 10) Turn cylinder head bolts to 60 to 65 degrees clockwise. If an angle wrench is not available, tighten cylinder head bolts to 54 to 64 N·m (5.5 to 6.5 kg·m, 40 to 47 ft·lb).
- 11) Tighten cylinder head sub-bolts to 9.0 to 11.8 N·m (0.92 to 1.20 kg·m, 79.9 to 104.2 in·lb).
- 12) Tighten intake manifold bolts and nuts to 4 N·m (0.4 kg·m, 35 in·lb).
- 13) Tighten intake manifold bolts and nuts to 9 N·m (0.9 kg·m, 78 in·lb).
- 14) Tighten intake manifold bolts and nuts to 8 to 10 N·m (0.8 to 1.0 kg·m, 69 to 87 in·lb).

CYLINDER HEAD

Installation (Cont'd)

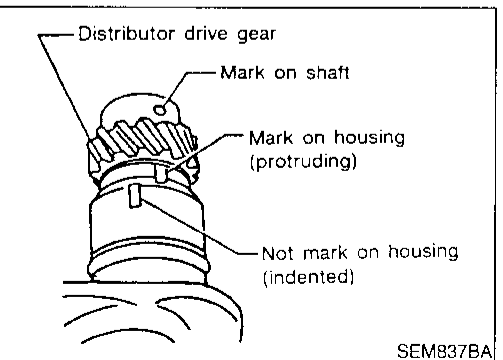
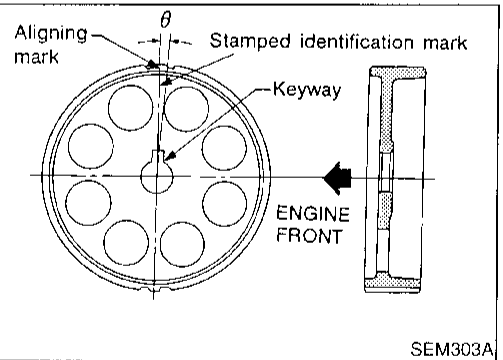
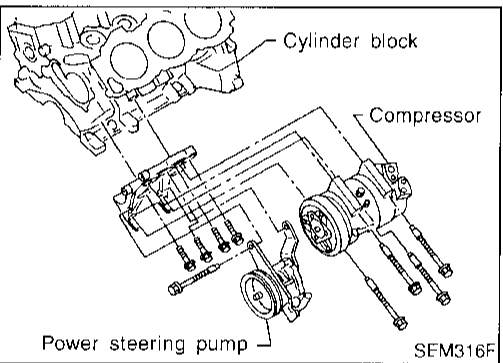
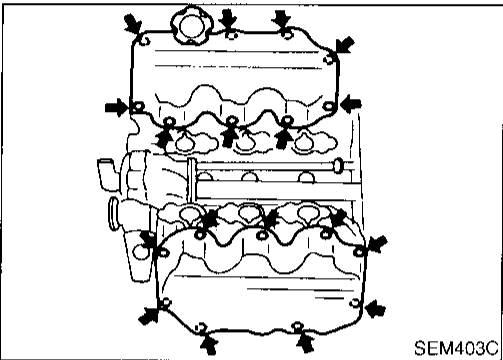
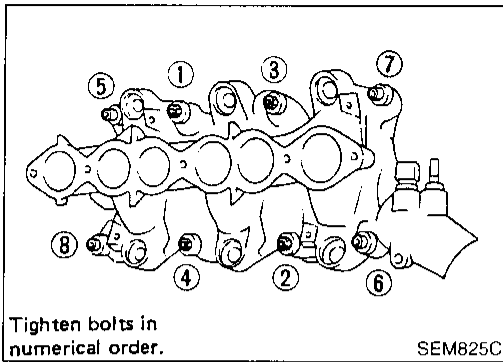

● If only intake manifold is removed and to be used again, install it using the following procedure:

- 1) Tighten all bolts and nuts to 4 N·m (0.4 kg-m, 35 in-lb).
- 2) Tighten all bolts and nuts to 9 N·m (0.9 kg-m, 78 in-lb).
- 3) Tighten all bolts and nuts to 8 to 10 N·m (0.8 to 1.0 kg-m, 69 to 87 in-lb).

CAUTION:

If replacing intake manifold with a new one, cylinder head gasket must also be replaced with a new one. Refer to step 4.

6. Install both rocker covers.

7. Install compressor and alternator bracket.

8. Install alternator.

9. Install compressor and power steering pump.

10. Install exhaust front tube to exhaust manifold.

11. Install rear belt cover and camshaft sprocket.

● RH camshaft sprocket and LH camshaft sprocket are different parts. Be sure to install them in the correct location.

	Identification mark	θ
RH camshaft sprocket	R3	$0^{\circ}53'$
LH camshaft sprocket	L3	$-3^{\circ}27'$

12. Install timing belt and adjust belt tension.

Refer to "TIMING BELT — Installation" (EM-20).

13. Install distributor.

- 1) Align mark on shaft with protruding mark on housing.

GI
MA
EM
LC
EC
FE
CL
MT
AT
TF
PD
AX
SU
BR
ST
RS
BT
HA
SC
EL
IDX

CYLINDER HEAD

Installation (Cont'd)

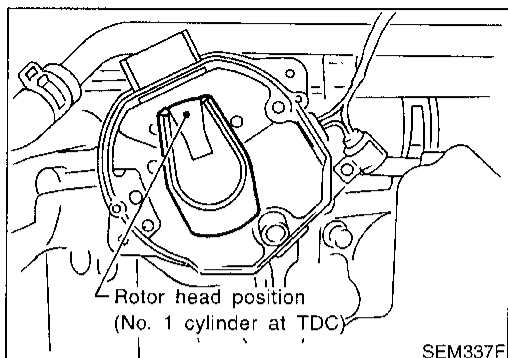

- 2) After installing, confirm that distributor rotor head is set as shown in figure.

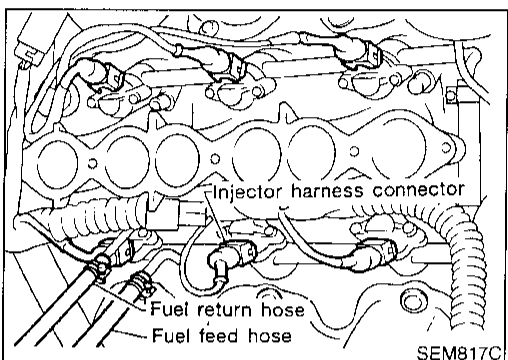

14. Install injector fuel tube assembly.
15. Connect all injector harness connectors.
16. Install fuel feed and fuel return hoses to injector fuel tube assembly.
17. Install intake manifold collector. Install all parts which were removed in step 5 under "CYLINDER HEAD — Removal" (EM-27).
18. Install ASCD and accelerator control wire.

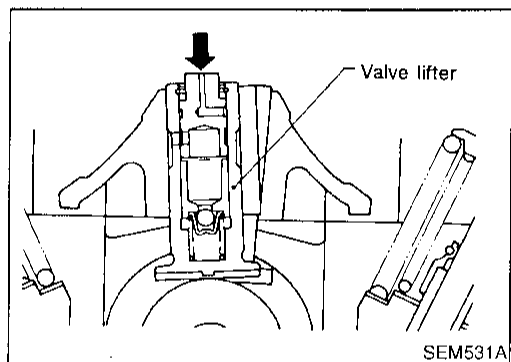

19. Check hydraulic valve lifter.
 - a. Push plunger forcefully with your finger.
 - **Be sure to check it with rocker arm in its free position (not on the lobe).**
 - b. If valve lifter moves more than 1 mm (0.04 in), air may be inside it.
 - c. Bleed air off by running engine at 1,000 rpm under no load for about 10 minutes.
 - d. If hydraulic valve lifters are still noisy, replace them and bleed air off again in the same manner as in step 19 (c).

Removal and Installation

NAEM0020

WARNING:

- Situate vehicle on a flat and solid surface.
- Place chocks at front and back of rear wheels.
- Do not remove engine until exhaust system has completely cooled off. Otherwise, you may burn yourself and/or fire may break out in fuel line.
- For safety during subsequent steps, the tension of wires should be slackened against the engine.
- Before disconnecting fuel hose, release fuel pressure from fuel line.
Refer to "Releasing Fuel Pressure" in EC section.
- Before removing front axle from transmission, place safety stands under designated front supporting points. Refer to GI section for lifting points and towing.
- Be sure to hoist engine and transmission in a safe manner.
- For engines not equipped with engine slingers, attach proper slingers and bolts described in PARTS CATALOG.

CAUTION:

- When lifting engine, be careful not to strike adjacent parts, especially accelerator wire casing, brake lines, and brake master cylinder.
- In hoisting the engine, always use engine slingers in a safe manner.
- Before separating engine and transmission, remove crankshaft position sensor (OBD) from the assembly.
- Always take extra care not to damage edge of crankshaft position sensor (OBD), or ring gear teeth.

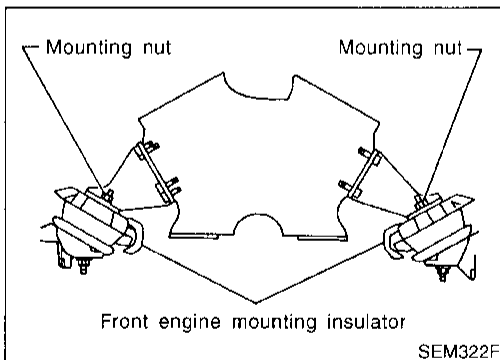

- Do not loosen front engine mounting insulator cover securing nuts.
When cover is removed, damper oil flows out and mounting insulator will not function.
For 4WD model, sealant should be applied between engine and transmission.
Refer to "Installation" in MT section.

GI

MA

EM

LC

EC

FE

CL

MT

AT

TF

PD

AX

SU

BR

ST

RS

BT

HA

SC

EL

IDX

ENGINE ASSEMBLY

Removal and Installation (Cont'd)

REMOVAL Front Engine Mounting

NAEM0020S01

NAEM0020S0101

SEC. 112

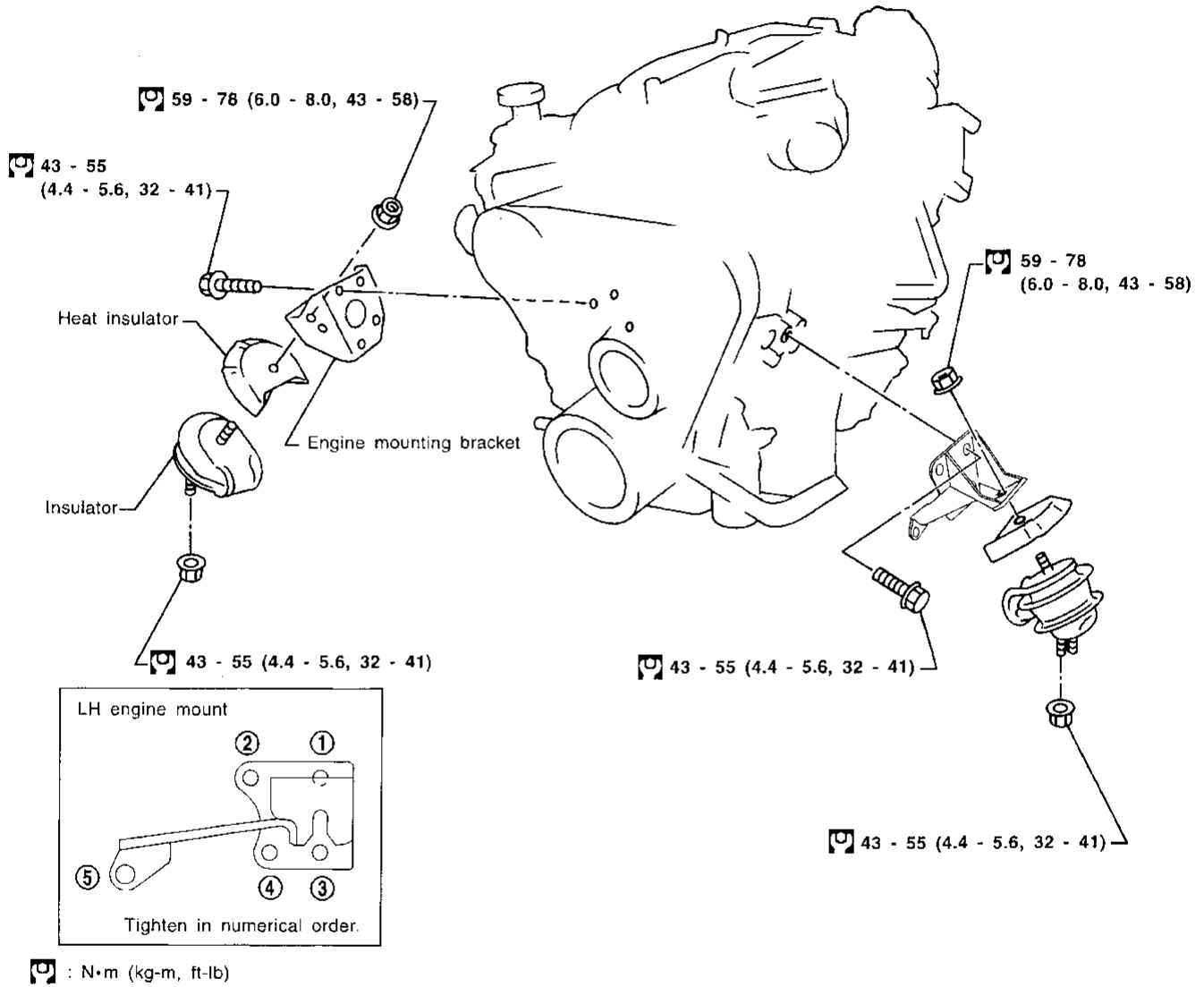

SEM851F

ENGINE ASSEMBLY

Removal and Installation (Cont'd)

Rear Engine Mounting

NAEM0020S0102

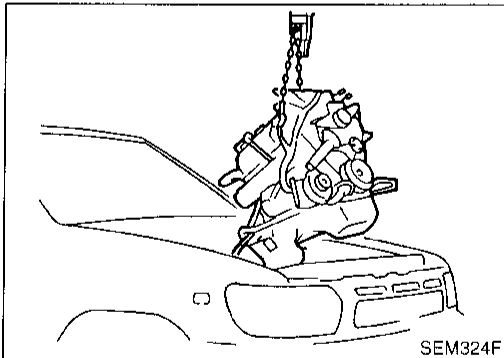
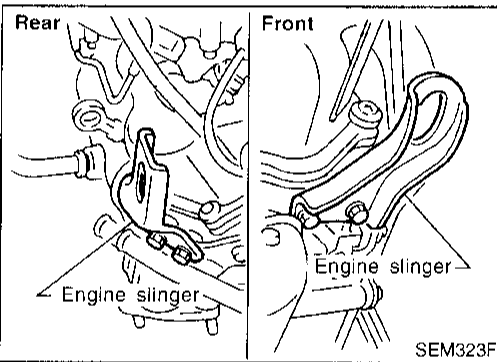
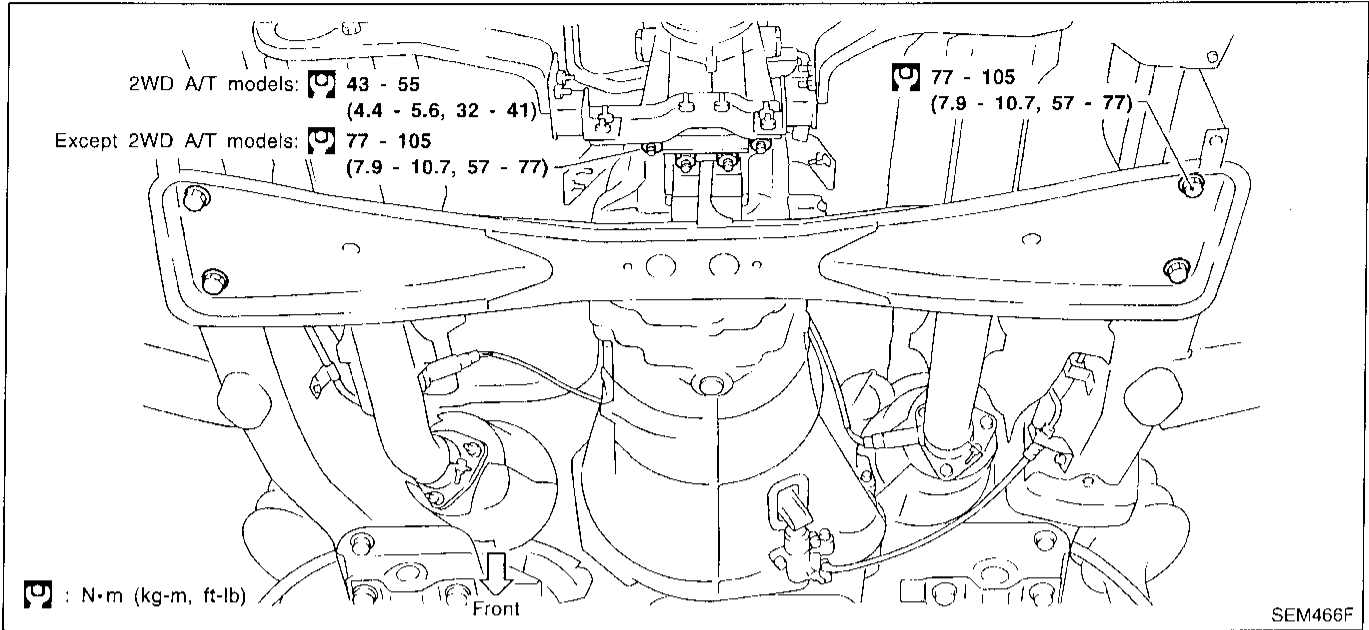

1. Remove engine undercover and hood.
2. Drain engine coolant.
3. Remove vacuum hoses, fuel tubes, wires, harnesses and connectors and so on.
4. Remove radiator with shroud and cooling fan.
5. Remove drive belts.
6. Remove power steering oil pump and air conditioner compressor.
7. Remove front exhaust tube.
8. Remove transmission from vehicle.

Refer to "Removal" in MT and AT sections.

9. Install engine slingers.

Slinger bolts:

\square : 20 - 26 N·m (2.1 - 2.7 kg-m, 15 - 20 ft-lb)

10. Hoist engine with engine slingers and remove engine mounting nuts from both sides.
11. Remove engine from vehicle.

GI

MA

EM

LC

EC

FE

CL

MT

AT

TF

PD

AX

SU

BR

ST

RS

BT

HA

SC

EL

IDX

CYLINDER BLOCK

Components

NAEM0021

Components

SEC. 110•120•150•313

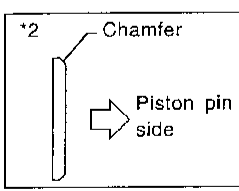
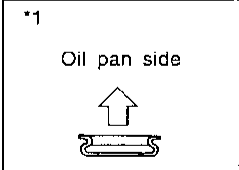
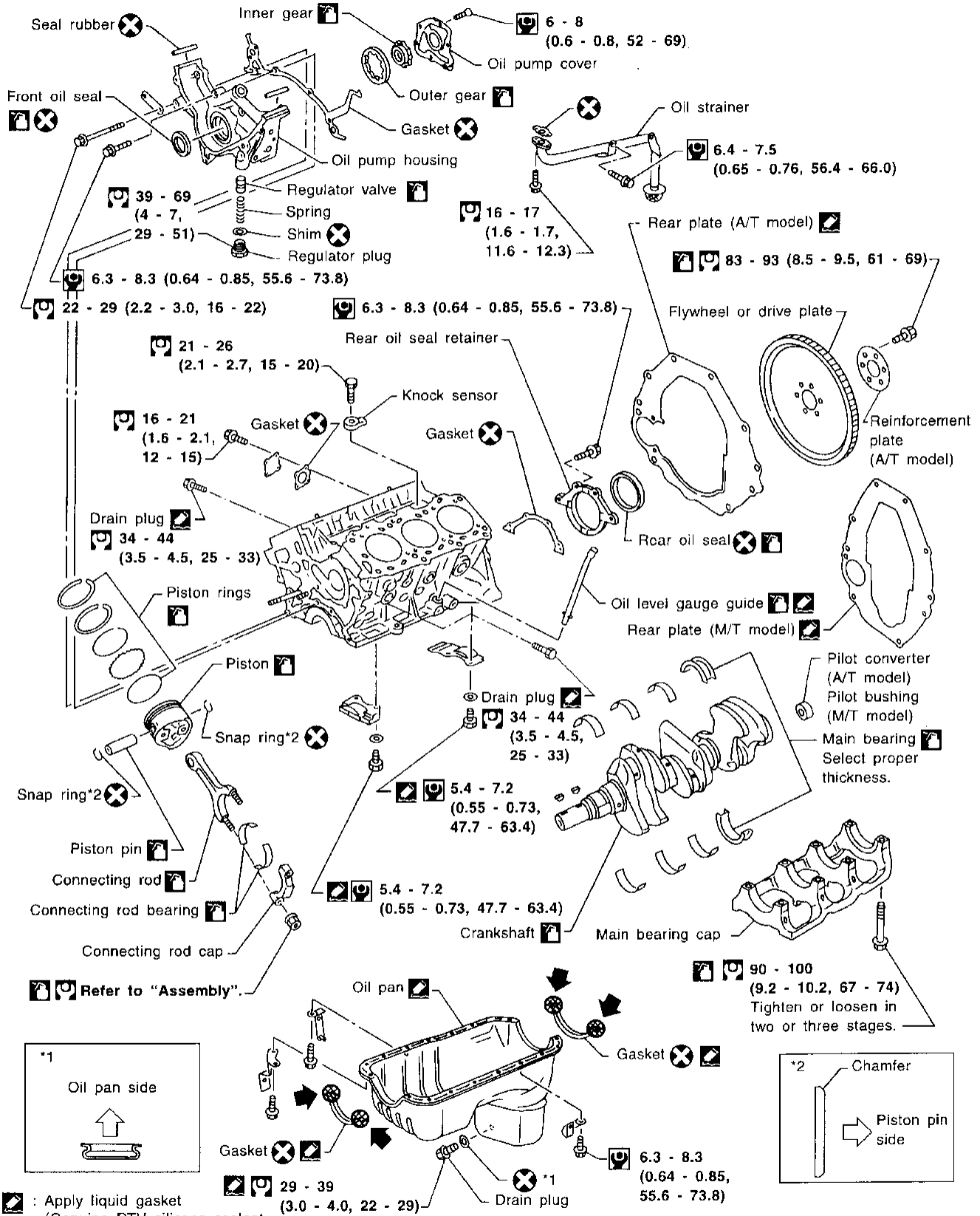

- : Apply liquid gasket (Genuine RTV silicone sealant Part No. 999MP-A7007 or equivalent).
- : N·m (kg-m, in-lb)
- : N·m (kg-m, ft-lb)
- : Apply sealant.
- : Lubricate with new engine oil.

SEM647FB

CYLINDER BLOCK HEATER

NAEM0021S01

GI

MA

EM

LC

EC

FE

CL

MT

AT

TF

PD

AX

SU

BR

ST

RS

BT

HA

SC

EL

IDX

137

For Canada
SEC. 110

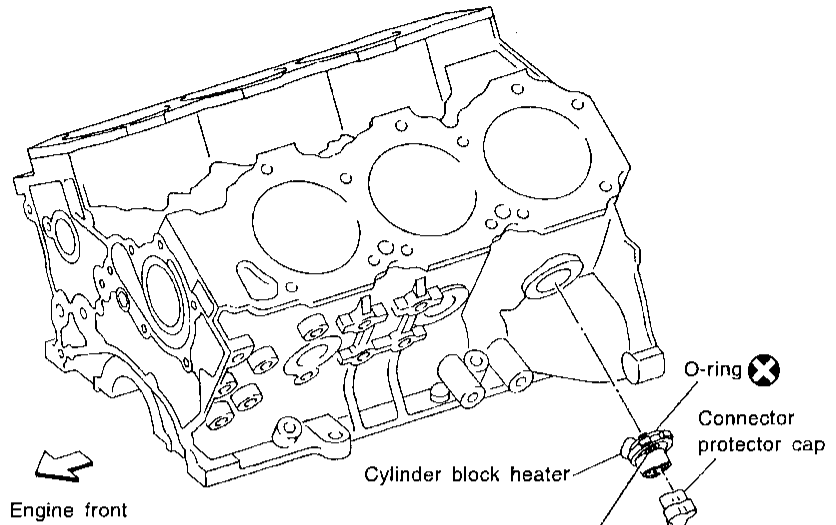
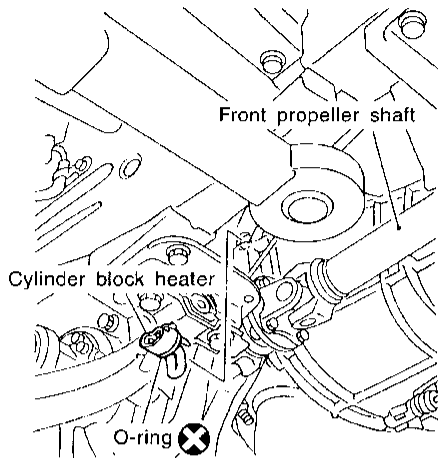

 1.6 - 2.2 N•m (0.16 - 0.22 kg-m, 13.9 - 19.1 in-lb)

- Remove liquid gasket completely after removing cylinder block heater.
- Install cylinder block heater with heater part downward as shown in the figure.
- Apply LLC to O-ring when installing cylinder block heater.

SEM625F

Refer to "OUTER COMPONENT PARTS" in EM-11 as to "Removal and Installation" for the procedures prior to removing the block heater.

Removal and Installation

NAEM0022

CAUTION:

- When installing sliding parts such as bearings and pistons, be sure to apply engine oil on the sliding surfaces.
- Place removed parts such as bearings and bearing caps in their proper order and direction.
- When installing connecting rod bolts and main bearing cap bolts, apply new engine oil to threads and seating surfaces.
- Do not allow any magnetic materials to contact the ring gear teeth on flywheel or drive plate and rear plate.

CYLINDER BLOCK

Disassembly

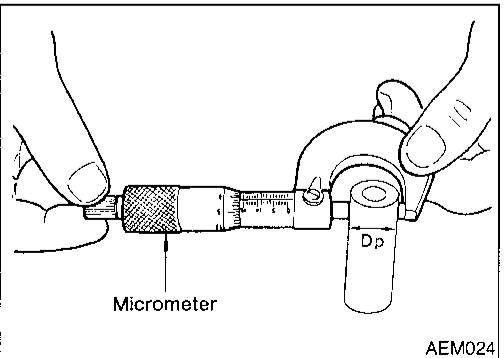
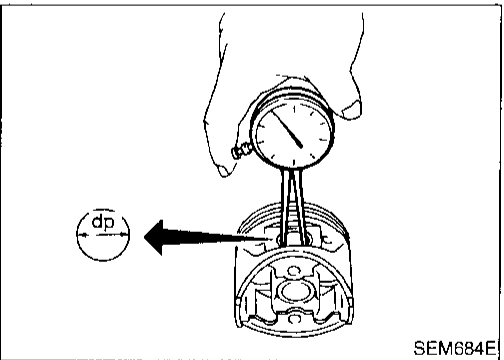
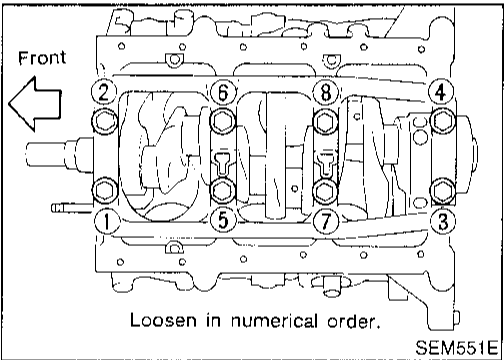
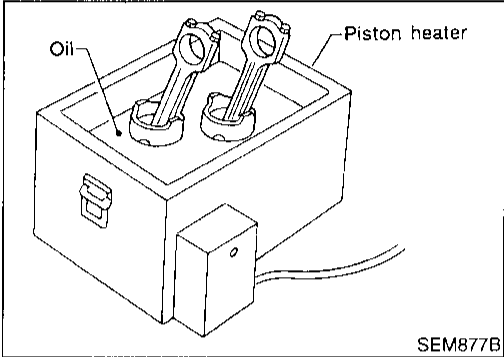
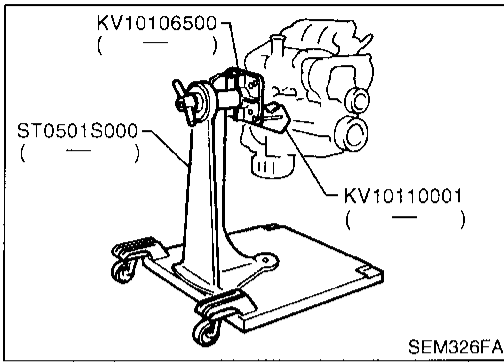

Disassembly PISTON AND CRANKSHAFT

NAEM0023

NAEM0023S01

1. Place engine on a work stand.
2. Drain coolant and oil.
3. Remove oil pan and oil pump.
4. Remove timing belt.
5. Remove water pump.
6. Remove cylinder head.

7. Remove pistons with connecting rods.

- When disassembling piston and connecting rod, remove snap ring first, then heat piston to 60 to 70°C (140 to 158°F) or use piston pin press stand at room temperature.

CAUTION:

- When piston rings are not replaced, make sure that piston rings are mounted in their original positions.
- When replacing piston rings, if there is no punchmark, install with either side up.

8. Remove bearing cap and crankshaft.

- Before removing bearing cap, measure crankshaft end play.
- Bolts should be loosened in two or three steps.

Inspection

PISTON AND PISTON PIN CLEARANCE

NAEM0024

NAEM0024S01

1. Measure inner diameter of piston pin hole "dp".

Standard diameter "dp":

20.969 - 20.981 mm (0.8255 - 0.8260 in)

2. Measure outer diameter of piston pin "Dp".

Standard diameter "Dp":

20.971 - 20.983 mm (0.8256 - 0.8261 in)

3. Calculate piston pin clearance.

dp - Dp = 0 - 0.004 mm (0 - 0.0002 in)

If it exceeds the above value, replace piston assembly with pin.

CYLINDER BLOCK

Inspection (Cont'd)

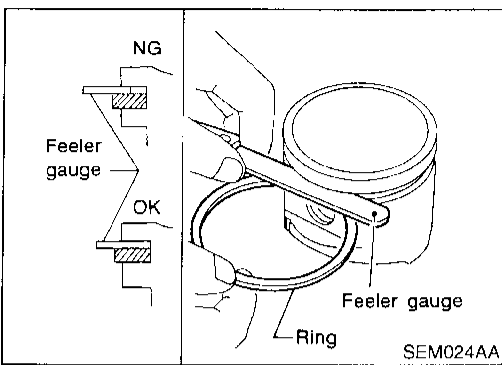

PISTON RING SIDE CLEARANCE

NAEM0024S02

Side clearance:

Top ring: 0.024 - 0.076 mm (0.0009 - 0.0030 in)
 2nd ring: 0.030 - 0.070 mm (0.0012 - 0.0028 in)

Max. limit of side clearance:

Top ring: 0.11 mm (0.0043 in)
 2nd ring: 0.1 mm (0.004 in)

If out of specification, replace piston and/or piston ring assembly.

GI

MA

EM

LC

EC

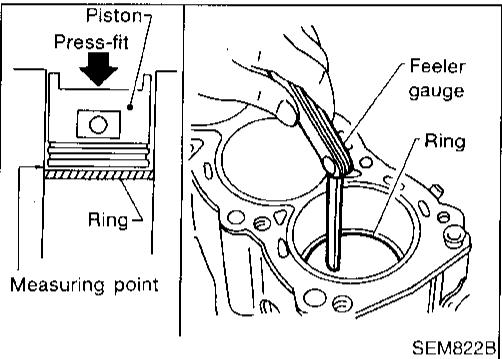

PISTON RING END GAP

NAEM0024S03

End gap:

Top ring: 0.21 - 0.40 mm (0.0083 - 0.0157 in)
 2nd ring: 0.50 - 0.69 mm (0.0197 - 0.0272 in)
 Oil ring: 0.20 - 0.69 mm (0.0079 - 0.0272 in)

Max. limit of ring gap:

Top ring: 0.54 mm (0.0213 in)
 2nd ring: 0.80 mm (0.0315 in)
 Oil ring: 0.95 mm (0.0374 in)

If out of specification, replace piston ring. If gap still exceeds the limit even with a new ring, rebore cylinder and use oversized piston and piston rings.

Refer to SDS (EM-64).

- When replacing the piston, check the cylinder block surface for scratches or seizure. If scratches or seizure are found, hone or replace the cylinder block.

FE

CL

MT

AT

TF

PD

AX

SU

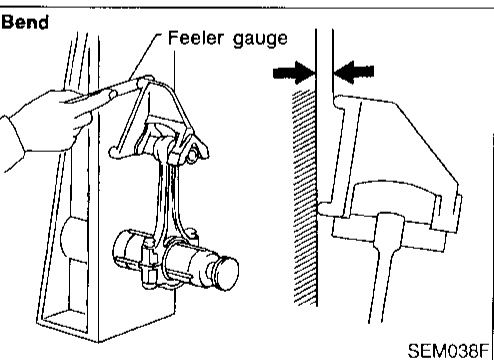

CONNECTING ROD BEND AND TORSION

NAEM0024S04

Bend:

Limit 0.15 mm (0.0059 in)
 per 100 mm (3.94 in) length

Torsion:

Limit 0.30 mm (0.0118 in)
 per 100 mm (3.94 in) length

If it exceeds the limit, replace connecting rod assembly.

BR

ST

RS

BT

HA

SC

EL

IDX

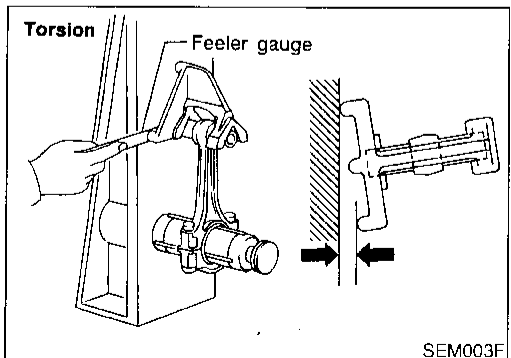

CYLINDER BLOCK

Inspection (Cont'd)

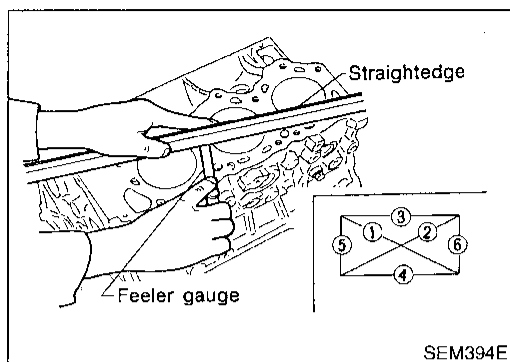

CYLINDER BLOCK DISTORTION AND WEAR

NAEM0024S05

1. Clean upper face of cylinder block and measure the distortion.
Limit:
0.10 mm (0.0039 in)

2. If out of specification, resurface it.
 The resurfacing limit is determined by cylinder head resurfacing in engine.

Amount of cylinder head resurfacing is "A".
Amount of cylinder block resurfacing is "B".

The maximum limit is as follows:

$$A + B = 0.2 \text{ mm (0.008 in)}$$

Nominal cylinder block height from crankshaft center:
227.60 - 227.70 mm (8.9606 - 8.9645 in)

3. If necessary, replace cylinder block.

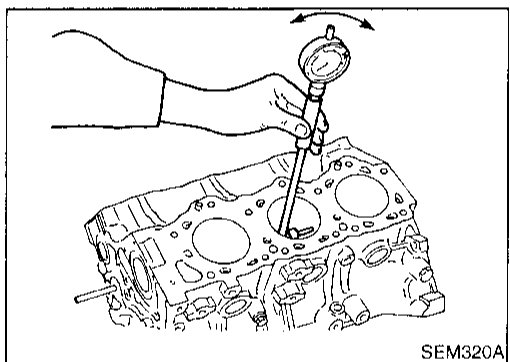

PISTON-TO-BORE CLEARANCE

NAEM0024S06

1. Using a bore gauge, measure cylinder bore for wear, out-of-round and taper.

Standard inner diameter:

$$91.500 - 91.530 \text{ mm (3.6024 - 3.6035 in)}$$

Refer to "CYLINDER BLOCK" in SDS.

Wear limit:

$$0.20 \text{ mm (0.0079 in)}$$

If it exceeds the limit, rebore all cylinders. Replace cylinder block if necessary.

Out-of-round (X - Y) standard:

$$0.015 \text{ mm (0.0006 in)}$$

Taper (A - B or A - C) standard:

$$0.015 \text{ mm (0.0006 in)}$$

2. Check for scratches and seizure. If seizure is found, hone it.

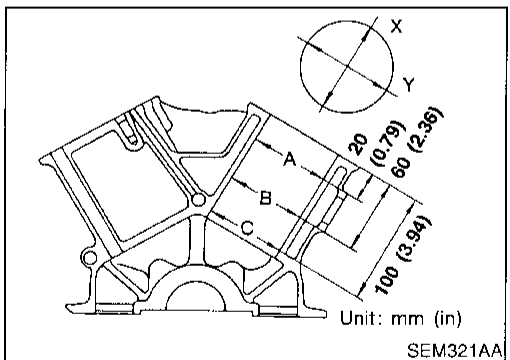

CYLINDER BLOCK

Inspection (Cont'd)

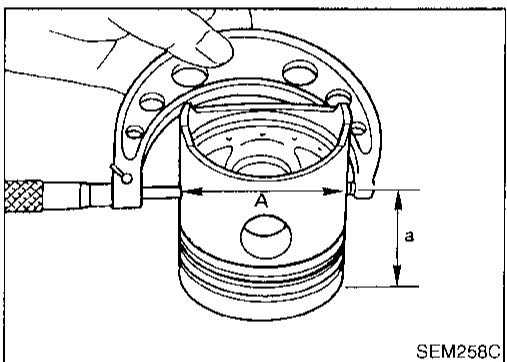
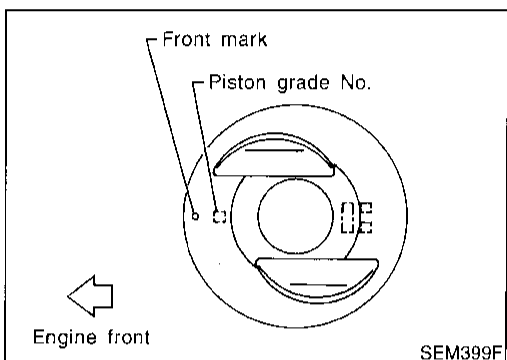
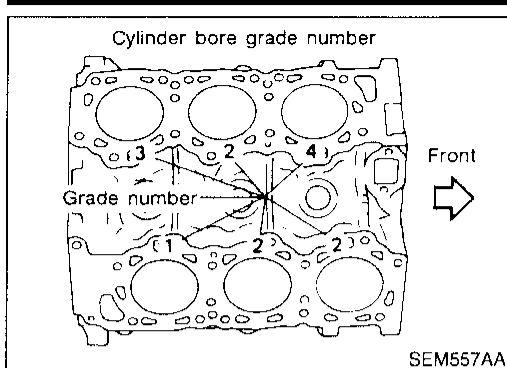

- If both cylinder block and piston are replaced with new ones, select piston of the same grade number according to the following table. These numbers are punched on cylinder block and piston in either Arabic or Roman numerals.

Combination of grade number for cylinder bore and piston

Cylinder bore grade No.	For No. 3 and 4 cylinders						Except for No. 3 and 4 cylinders		
	1	2	3	4	5	6	1	2	3
Piston grade No.	2-1	3-2	3-3	4-4	4-5	5-6	1	2	3

3. Measure piston skirt diameter.
Piston diameter "A":
Refer to SDS (EM-64).
Measuring point "a" (Distance from the top):
49.0 mm (1.929 in)
4. Check that piston-to-bore clearance is within specification.
Piston-to-bore clearance "B":
0.015 - 0.025 mm (0.0006 - 0.0010 in) for No. 3 and 4 cylinders
0.025 - 0.045 mm (0.0010 - 0.0018 in) except for No. 3 and 4 cylinders
5. Determine piston oversize according to amount of cylinder wear.

Oversize pistons are available for service. Refer to SDS (EM-64).

6. Cylinder bore size is determined by adding piston-to-bore clearance to piston diameter "A".

Rebored size calculation:

$$D = A + B - C$$

where,

D: Bored diameter

A: Piston diameter as measured

B: Piston-to-bore clearance

C: Honing allowance 0.02 mm (0.0008 in)

7. Install main bearing caps, and tighten to the specified torque to prevent distortion of cylinder bores in final assembly.
8. Cut cylinder bores.
 - When any cylinder needs boring, all other cylinders must also be bored.
 - Do not cut too much out of cylinder bore at a time. Cut only 0.05 mm (0.0020 in) or so in diameter at a time.
- 9.hone cylinders to obtain specified piston-to-bore clearance.

GI
MA
EM
LC
EC
FE
CL
MT
AT
TF
PD
AX
SU
BR
ST
RS
BT
HA
SC
EL
IDX

CYLINDER BLOCK

Inspection (Cont'd)

10. Measure finished cylinder bore for out-of-round and taper.
 - **Measurement should be done after cylinder bore cools down.**

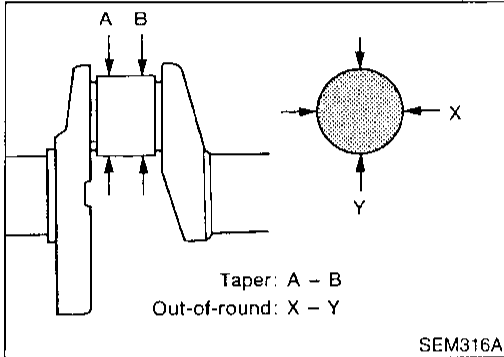

CRANKSHAFT

NAEM0024507

1. Check crankshaft main and pin journals for score, wear or cracks.
2. With a micrometer, measure journals for taper and out-of-round.

Out-of-round (X - Y):

Less than 0.005 mm (0.0002 in)

Taper (A - B):

Less than 0.005 mm (0.0002 in)

3. Measure crankshaft runout.

Runout (Total indicator reading):

Less than 0.10 mm (0.0039 in)

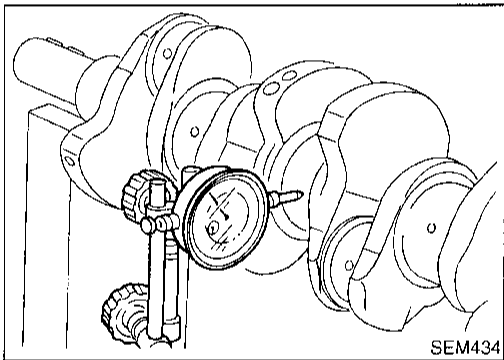

BEARING CLEARANCE

NAEM0024508

- Either of the following two methods may be used, however, method A gives more reliable results and is preferable.

Method A (Using bore gauge & micrometer)

Main Bearing

NAEM002450801

1. Set main bearings in their proper positions on cylinder block and main bearing cap.

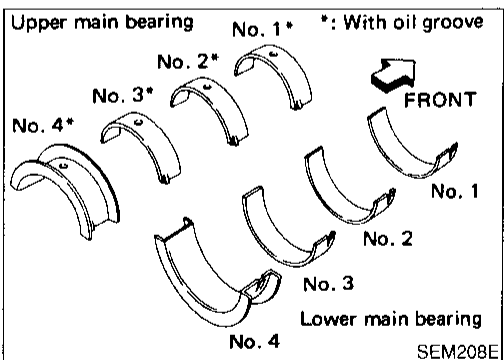

2. Install main bearing cap to cylinder block.

Tighten all bolts in correct order in two or three stages.

3. Measure inner diameter "A" of each main bearing.

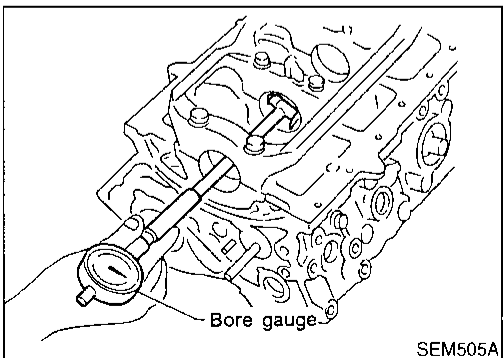

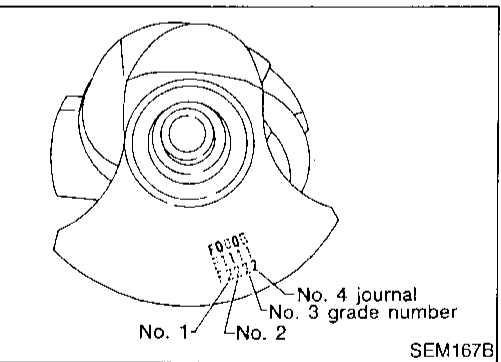
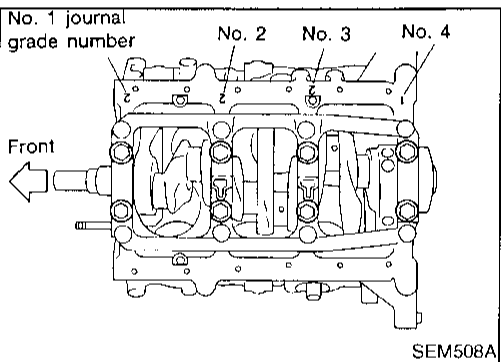
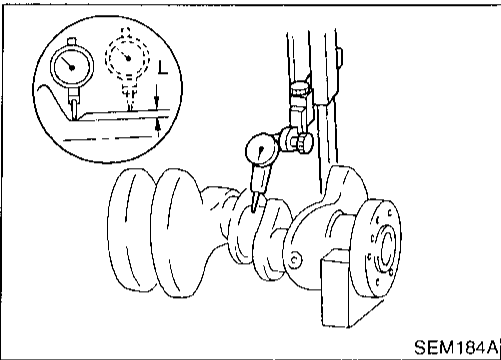
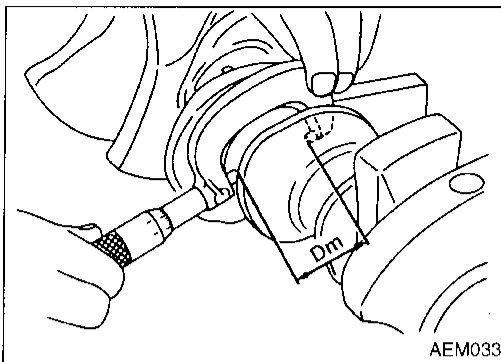

4. Measure outer diameter "Dm" of each crankshaft main journal.
5. Calculate main bearing clearance.

Main bearing clearance (A - Dm):

Standard

0.028 - 0.055 mm (0.0011 - 0.0022 in)

Limit

0.090 mm (0.0035 in)

6. If it exceeds the limit, replace bearing.
7. If clearance cannot be adjusted within the standard of any bearing, grind crankshaft journal and use undersized bearing.

- a. When grinding crankshaft journal, confirm that "L" dimension in fillet roll is more than the specified limit.

"L": 0.1 mm (0.004 in)

- b. Refer to SDS for grinding crankshaft and available service parts.

8. If crankshaft is reused, measure main bearing clearances and select thickness of main bearings.

If crankshaft is replaced with a new one, it is necessary to select thickness of main bearings as follows:

- a. Grade number of each cylinder block main journal is punched on the respective cylinder block. These numbers are punched in either Arabic or Roman numerals.

- b. Grade number of each crankshaft main journal is punched on the respective crankshaft. These numbers are punched in either Arabic or Roman numerals.

- c. Select main bearing with suitable thickness according to the following example or table.

Main bearing grade number

No. 1 main bearing

(Identification color):

Crankshaft main journal grade number	Cylinder block main journal grade number			
	0	1	2	3
0	0 (Black)	1 (Brown)	2 (Green)	3 (Yellow)
1	1 (Brown)	2 (Green)	3 (Yellow)	4 (Blue)
2	2 (Green)	3 (Yellow)	4 (Blue)	5 (Pink)
3	3 (Yellow)	4 (Blue)	5 (Pink)	6 (Purple)

CYLINDER BLOCK

Inspection (Cont'd)

No. 2, 3 and No. 4 main bearings (Identification color):

		Main journal grade number		
		0	1	2
Crankshaft journal grade number	0	0 (Yellow)	1 (Green)	2 (Brown)
	1	1 (Green)	2 (Brown)	3 (Black)
	2	2 (Brown)	3 (Black)	4 (Blue)

For example:

Main journal grade number: 1

Crankshaft journal grade number: 2

Main bearing grade number = 1 + 2 = 3 (Yellow)

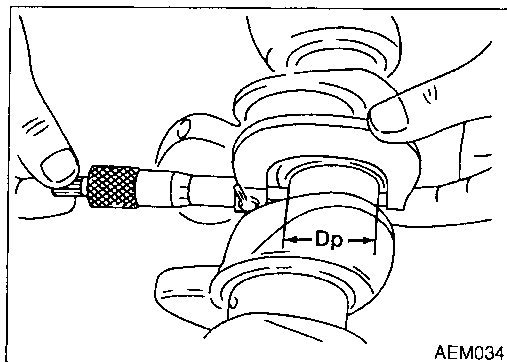
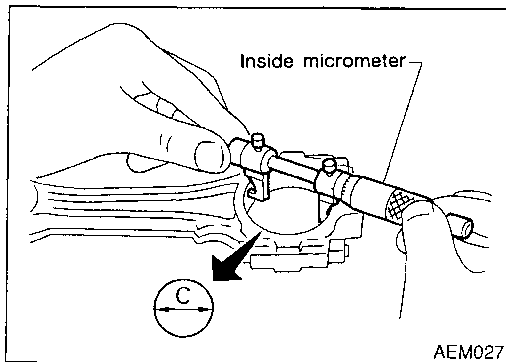

Connecting Rod Bearing (Big end)

1. Install connecting rod bearing to connecting rod and cap. NAEM002450802
 2. Install connecting rod cap to connecting rod.
- Tighten bolts to the specified torque.**
3. Measure inner diameter "C" of each bearing.

4. Measure outer diameter "Dp" of each crankshaft pin journal.
5. Calculate connecting rod bearing clearance.

Connecting rod bearing clearance (C - Dp):

Standard

0.014 - 0.054 mm (0.0006 - 0.0021 in)

Limit

0.090 mm (0.0035 in)

6. If it exceeds the limit, replace bearing.
7. If clearance cannot be adjusted within the standard of any bearing, grind crankshaft journal and use undersized bearing. Refer to step 7 of "BEARING CLEARANCE — Main bearing" (EM-50).

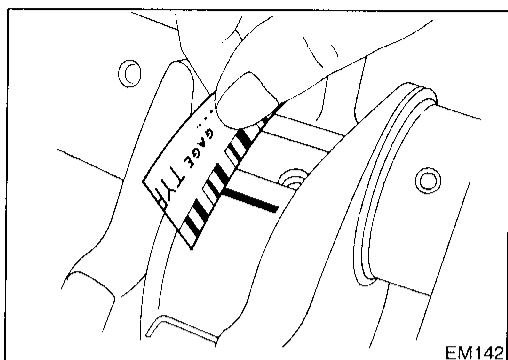

Method B (Using plastigage)

CAUTION:

- Do not turn crankshaft or connecting rod while plastigage is being inserted.
- When bearing clearance exceeds the specified limit, ensure that the proper bearing has been installed. Then if excessive bearing clearance exists, use a thicker main bearing or undersized bearing so that the specified bearing clearance is obtained.

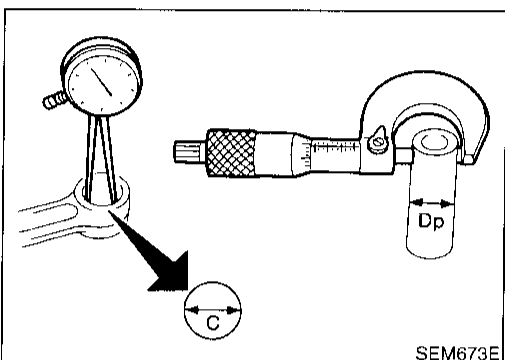

CONNECTING ROD BUSHING CLEARANCE (SMALL END)

NAEM0024S09

1. Measure inner diameter "C" of bushing.
2. Measure outer diameter "Dp" of piston pin.
3. Calculate connecting rod bushing clearance.

$$\text{Connecting rod bushing clearance} = C - Dp$$

Standard: 0.005 - 0.017 mm (0.0002 - 0.0007 in)
Limit: 0.023 mm (0.0009 in)

If it exceeds the limit, replace connecting rod assembly or connecting rod bushing and/or piston set with pin.

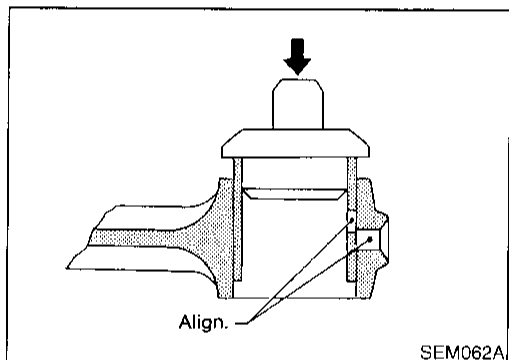

REPLACEMENT OF CONNECTING ROD BUSHING (SMALL END)

NAEM0024S10

1. Drive in small end bushing until it is flush with end surface of rod.

Be sure to align the oil holes.

2. After driving in small end bushing, ream the bushing so that clearance between connecting rod bushing and piston pin is the specified value.

Clearance between connecting rod bushing and piston pin:

$$0.005 - 0.017 \text{ mm (0.0002 - 0.0007 in)}$$

FLYWHEEL/DRIVE PLATE RUNOUT

NAEM0024S11

Runout (Total indicator reading):

Flywheel (M/T model)

Less than 0.15 mm (0.0059 in)

Drive plate (A/T model)

Less than 0.15 mm (0.0059 in)

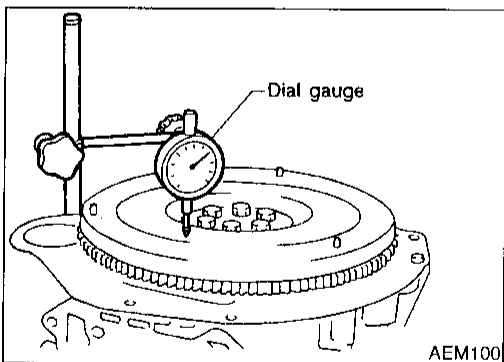

CAUTION:

- Be careful not to damage the ring gear teeth.
- Check the drive plate for deformation or cracks.
- Do not allow any magnetic materials to contact the ring gear teeth.
- Do not surface flywheel. Replace as necessary.

CYLINDER BLOCK

Assembly

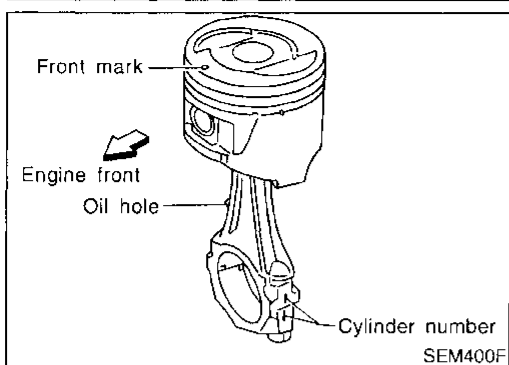

Assembly

NAEM0025

PISTON

NAEM0025S01

1. Install new snap ring on one side of piston pin hole.
2. Heat piston to 60 to 70°C (140 to 158°F) and assemble piston, piston pin, connecting rod and new snap ring.
 - **Align the direction of piston and connecting rod.**
 - **Numbers stamped on connecting rod and cap correspond to each cylinder.**
 - **After assembly, make sure connecting rod swings smoothly.**
3. Set piston rings as shown.

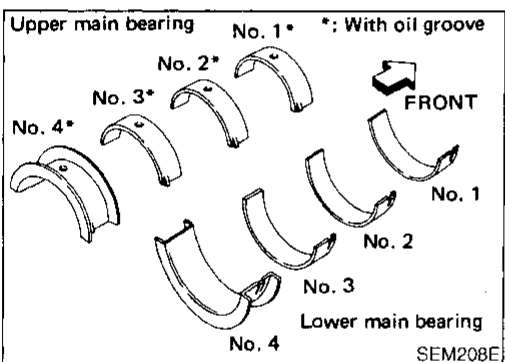
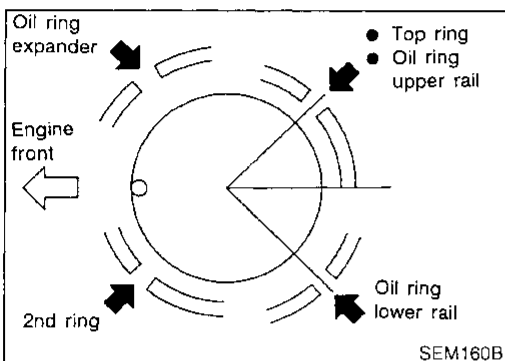

CRANKSHAFT

NAEM0025S02

1. Set main bearings in their proper positions on cylinder block and main bearing cap.
 - **Confirm that correct main bearings are used.**
- Refer to "Inspection" (EM-50).

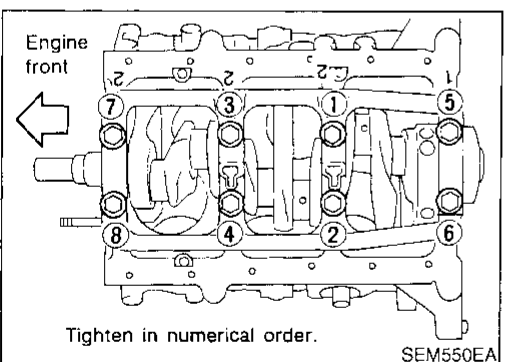

2. Install crankshaft and main bearing caps and tighten bolts to the specified torque.
 - **Prior to tightening bearing cap bolts, place bearing cap in its proper position by shifting crankshaft in the axial direction.**
 - **Tighten bearing cap bolts gradually in two or three stages. Start with center bearing and move outward sequentially.**
 - **After securing bearing cap bolts, make sure crankshaft turns smoothly by hand.**
 - **Lubricate threads and seat surfaces of the bolts with new engine oil.**

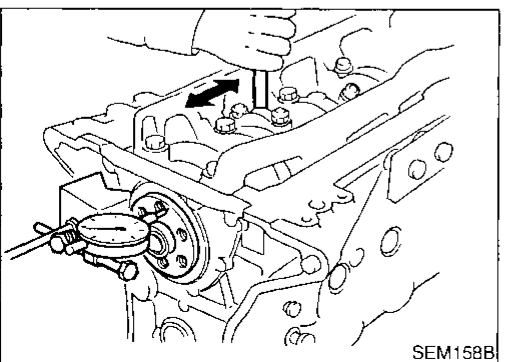

3. Measure crankshaft end play.

Crankshaft end play:

Standard

0.050 - 0.170 mm (0.0020 - 0.0067 in)

Limit

0.30 mm (0.0118 in)

If beyond the limit, replace bearing with a new one.

CYLINDER BLOCK

Assembly (Cont'd)

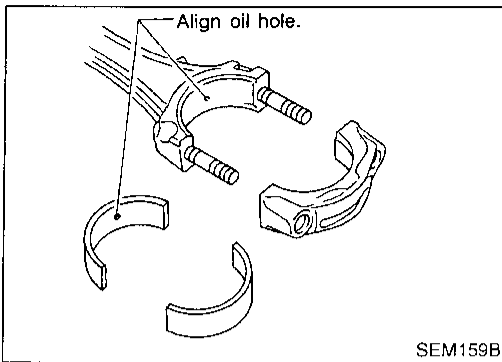

4. Install connecting rod bearings in connecting rods and connecting rod caps.

- **Confirm that correct bearings are used.**

Refer to "Inspection".

- Install bearings so that oil hole in connecting rod aligns with oil hole of bearing.

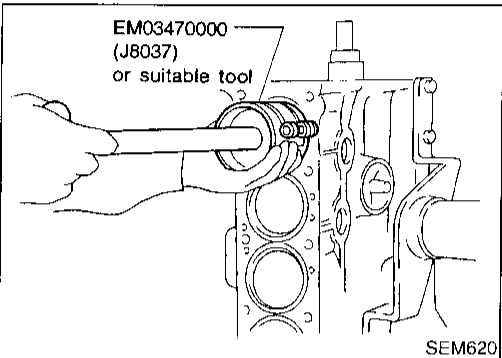

5. Install pistons with connecting rods.

- a. Install them into corresponding cylinders with Tool.

- **Be careful not to scratch cylinder wall by connecting rod.**
- **Arrange so that front mark on piston head faces toward front of engine.**

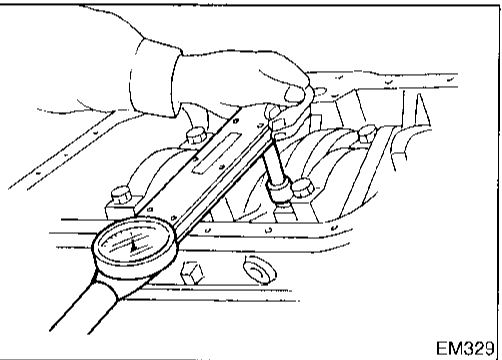

- b. Install connecting rod bearing caps.

- **Lubricate threads and seat surfaces with new engine oil.** Tighten connecting rod bearing cap nuts to the specified torque.

 : Connecting rod bearing nut

(1) Tighten to 14 to 16 N·m (1.4 to 1.6 kg·m, 10 to 12 ft·lb).

(2) Turn nuts 60 to 65 degrees clockwise. If an angle wrench is not available, tighten nuts to 38 to 44 N·m (3.9 to 4.5 kg·m, 28 to 33 ft·lb).

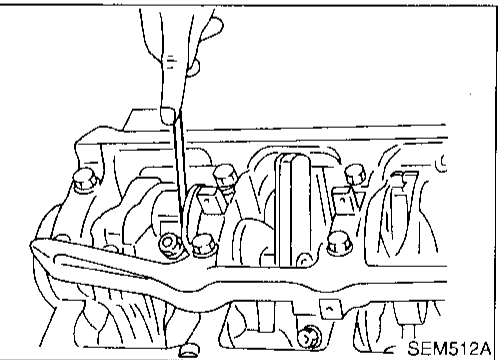

6. Measure connecting rod side clearance.

Connecting rod side clearance:

Standard

0.20 - 0.35 mm (0.0079 - 0.0138 in)

Limit

0.40 mm (0.0157 in)

If beyond the limit, replace connecting rod and/or crankshaft.

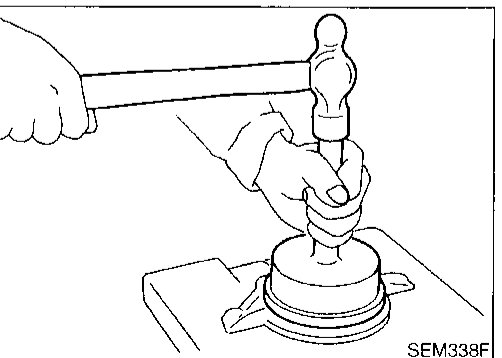

7. Install rear oil seal retainer.

GI
MA
EM
LC
EC
FE
CL
MT
AT
TF
PD
AX
SU
BR
ST
RS
BT
HA
SC
EL
IDX

CYLINDER BLOCK

Assembly (Cont'd)

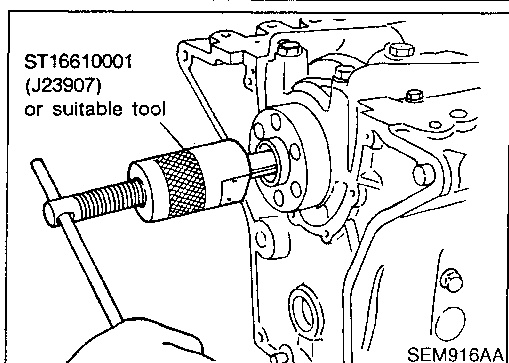

REPLACING PILOT BUSHING (M/T) OR PILOT CONVERTER (A/T)

NAEM0025S03

1. Remove pilot bushing (M/T) or pilot converter (A/T).

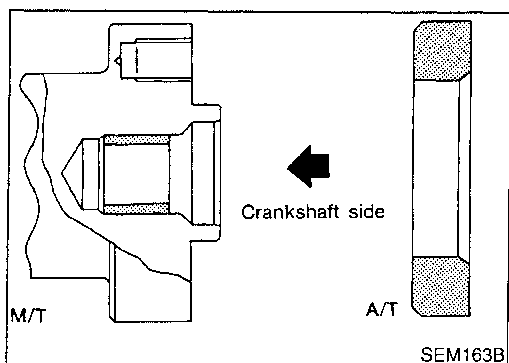

2. Install pilot bushing (M/T) or pilot converter (A/T).

SERVICE DATA AND SPECIFICATIONS (SDS)

General Specifications

General Specifications

NAEM0026

Cylinder arrangement		V-6
Displacement		3,275 cm ³ (199.84 cu in)
Bore and stroke		91.5 x 83 mm (3.602 x 3.27 in)
Valve arrangement		OHC
Firing order		1-2-3-4-5-6
Number of piston rings	Compression	2
	Oil	1
Number of main bearings		4
Compression ratio		8.9

GI

MA

EM

LC

EC

FE

CL

MT

AT

TF

PD

AX

SU

BR

ST

RS

BT

HA

SC

EL

IDX

149

Cylinder number

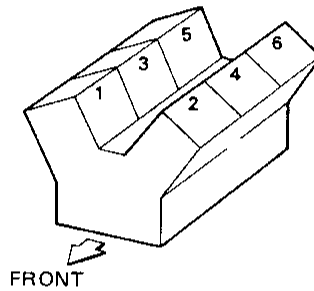

SEM713A

Unit: kPa (kg/cm², psi)/300 rpm

Compression pressure	Standard	1,196 (12.2, 173)
	Minimum	883 (9.0, 128)
	Differential limit between cylinders	98 (1.0, 14)

Unit: degree

Valve timing

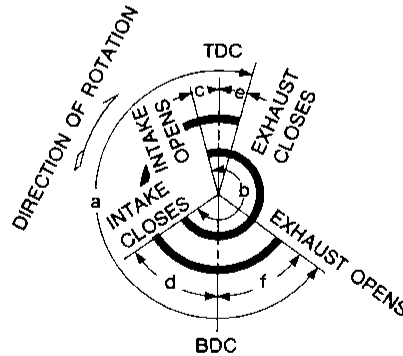

EM120

a	b	c	d	e	f
240	244	4	60	9	51

SERVICE DATA AND SPECIFICATIONS (SDS)

Cylinder Head

Cylinder Head

NAEM0027
Unit: mm (in)

	Standard	Limit
Head surface distortion	Less than 0.03 (0.0012)	0.1 (0.004)

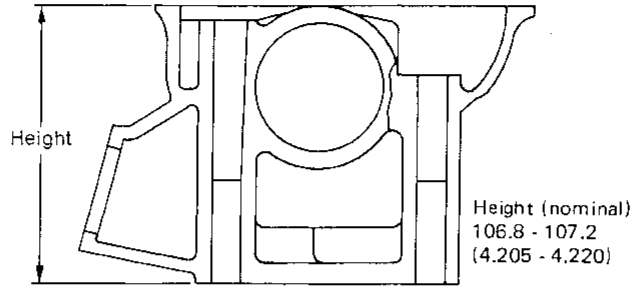

SEM082B

Valve

VALVE

NAEM0028

NAEM0028S01
Unit: mm (in)

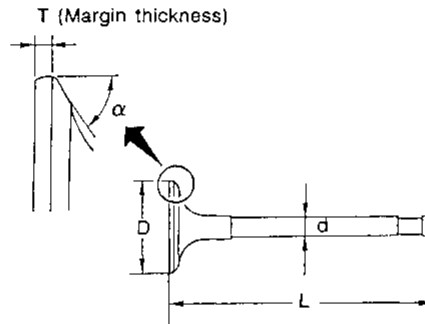

SEM188

Valve head diameter "D"	Intake	41.95 - 42.25 (1.6516 - 1.6634)
	Exhaust	35.0 - 35.2 (1.378 - 1.386)
Valve length "L"	Intake	125.3 - 125.9 (4.933 - 4.957)
	Exhaust	124.2 - 124.8 (4.890 - 4.913)
Valve stem diameter "d"	Intake	6.965 - 6.980 (0.2742 - 0.2748)
	Exhaust	7.962 - 7.970 (0.3135 - 0.3138)
Valve seat angle "α"	Intake	45°15' - 45°45'
	Exhaust	
Valve margin "T"	Intake	1.15 - 1.45 (0.0453 - 0.0571)
	Exhaust	1.35 - 1.65 (0.0531 - 0.0650)
Valve margin "T" limit		More than 0.5 (0.020)
Valve stem end surface grinding limit		Less than 0.2 (0.008)
Valve clearance	Intake	0 (0)
	Exhaust	0 (0)

SERVICE DATA AND SPECIFICATIONS (SDS)

Valve (Cont'd)

VALVE SPRING

NAEM0028S02

Free height	50.47 mm (1.9870 in)
Pressure	790 N (80.6 kg, 178 lb) at 30.0 mm (1.181 in)
Limit pressure	733 N (74.7 kg, 165 lb) at 30.0 mm (1.181 in)
Out-of-square	2.2 mm (0.087 in)

HYDRAULIC VALVE LIFTER

NAEM0028S03
Unit: mm (in)

Lifter outside diameter	15.947 - 15.957 (0.6278 - 0.6282)
Lifter guide inside diameter	16.000 - 16.013 (0.6299 - 0.6304)
Clearance between lifter and lifter guide	0.043 - 0.066 (0.0017 - 0.0026)

VALVE GUIDE

NAEM0028S04
Unit: mm (in)

			Standard	Service
Valve guide	Outer diameter	Intake	11.023 - 11.034 (0.4340 - 0.4344)	11.223 - 11.234 (0.4418 - 0.4423)
		Exhaust	12.023 - 12.034 (0.4733 - 0.4738)	12.223 - 12.234 (0.4812 - 0.4817)
	Inner diameter (Finished size)	Intake	7.000 - 7.018 (0.2756 - 0.2763)	
		Exhaust	8.000 - 8.011 (0.3150 - 0.3154)	
Cylinder head valve guide hole diameter	Intake	10.975 - 10.996 (0.4321 - 0.4329)	11.175 - 11.196 (0.4400 - 0.4408)	
	Exhaust	11.975 - 11.996 (0.4715 - 0.4723)	12.175 - 12.196 (0.4793 - 0.4802)	
Interference fit of valve guide	Intake	0.027 - 0.059 (0.0011 - 0.0023)		
	Exhaust			
Stem to guide clearance			Standard	Max. tolerance
	Intake	0.020 - 0.053 (0.0008 - 0.0021)	0.10 (0.0039)	
	Exhaust	0.040 - 0.049 (0.0016 - 0.0019)		
Valve deflection limit			—	0.20 (0.0079)

ROCKER SHAFT AND ROCKER ARM

NAEM0028S05
Unit: mm (in)

Rocker shaft	Outer diameter	17.979 - 18.000 (0.7078 - 0.7087)
Rocker arm	Inner diameter	18.007 - 18.028 (0.7089 - 0.7098)
Clearance between rocker arm and rocker shaft		0.007 - 0.049 (0.0003 - 0.0019)

SERVICE DATA AND SPECIFICATIONS (SDS)

Valve Seat

Valve Seat

NAEM0029

INTAKE VALVE SEAT

NAEM0029S01

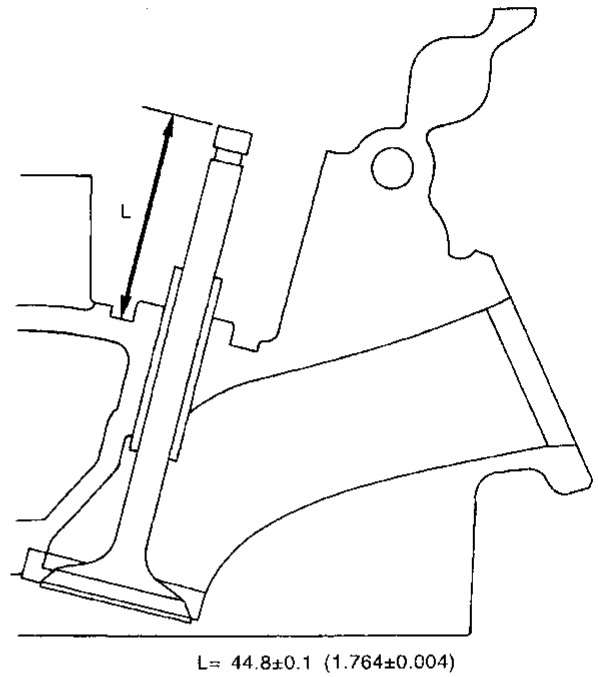
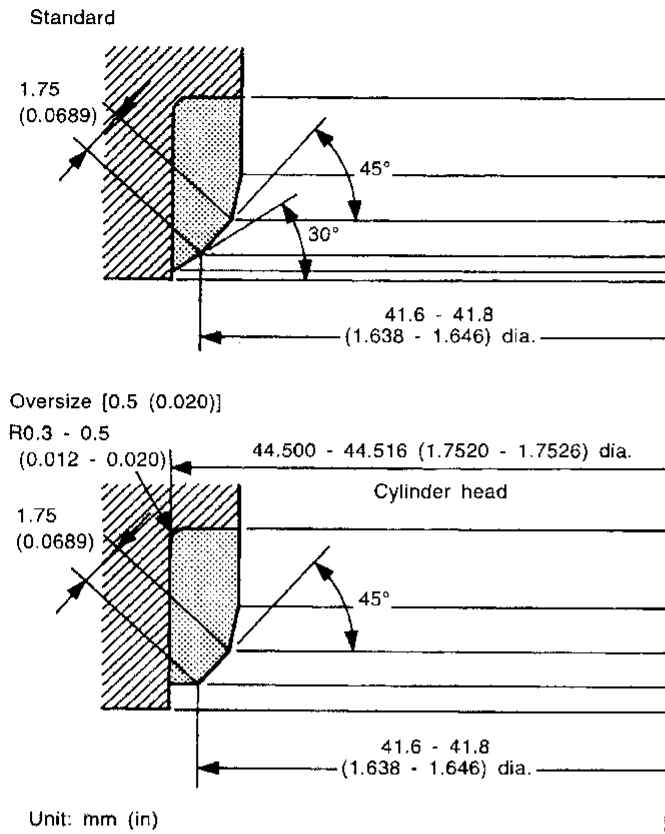

SEM639F

EXHAUST VALVE SEAT

NAEM0029S02

GI

MA

EM

LC

EC

FE

CL

MT

AT

TF

PD

AX

SU

BR

ST

RS

BT

HA

SC

EL

IDX

153

Standard

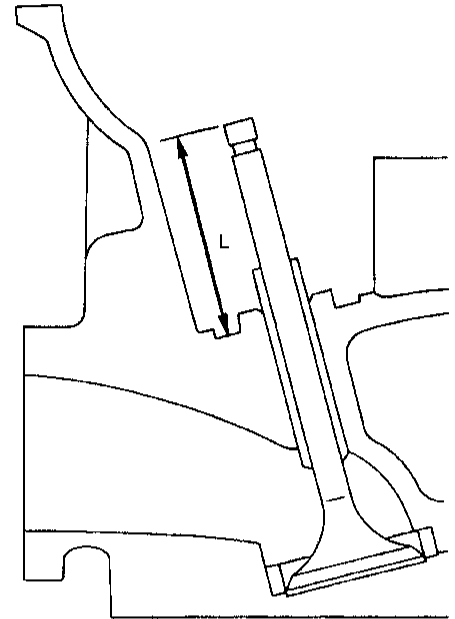
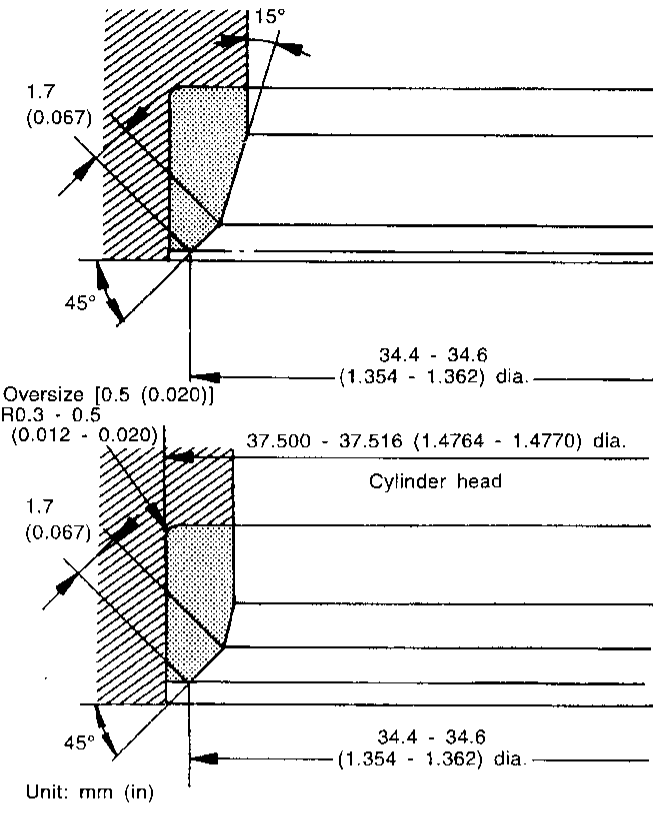

L = 45.5 ± 0.1 (1.791 ± 0.004)

SEM640F

SERVICE DATA AND SPECIFICATIONS (SDS)

Camshaft and Camshaft Bearing

Camshaft and Camshaft Bearing

NAEM0030
Unit: mm (in)

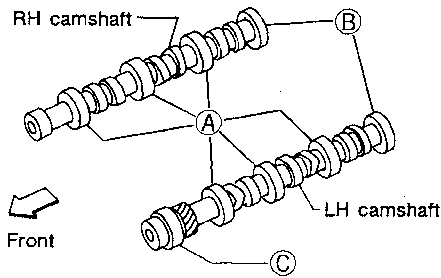

SEM893BA

	Standard	Max. tolerance
Camshaft journal to bearing clearance	0.060 - 0.105 (0.0024 - 0.0041)	0.15 (0.0059)
Inner diameter of camshaft bearing	A: 47.000 - 47.025 (1.8504 - 1.8514)	—
	B: 42.500 - 42.525 (1.6732 - 1.6742)	—
	C: 48.000 - 48.025 (1.8898 - 1.8907)	—
Outer diameter of camshaft journal	A: 46.920 - 46.940 (1.8472 - 1.8480)	—
	B: 42.420 - 42.440 (1.6701 - 1.6709)	—
	C: 47.920 - 47.940 (1.8866 - 1.8874)	—
Camshaft runout [TIR*]	Less than 0.04 (0.0016)	0.1 (0.004)
Camshaft end play	0.03 - 0.06 (0.0012 - 0.0024)	—

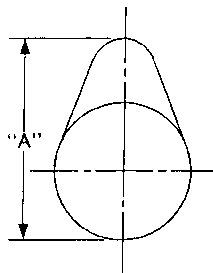

EM671

Cam height "A"	Intake	38.943 - 39.133 (1.5332 - 1.5407)
	Exhaust	38.943 - 39.133 (1.5332 - 1.5407)
Wear limit of cam height		0.15 (0.0059)

*Total indicator reading

SERVICE DATA AND SPECIFICATIONS (SDS)

Cylinder Block

Cylinder Block

Unit: mm (in)

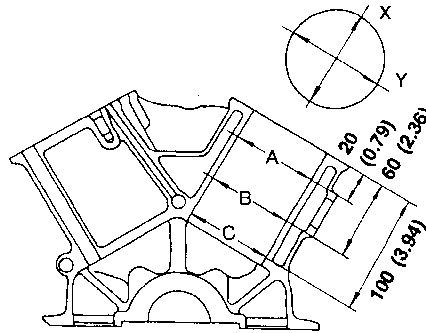

SEM321A

Surface flatness		Standard		Less than 0.03 (0.0012)
		Limit		0.10 (0.0039)
Cylinder bore	Inner diameter	Standard (for No. 3 and 4 cylinders)	Grade No. 1	91.500 - 91.505 (3.6024 - 3.6026)
			Grade No. 2	91.506 - 91.510 (3.6026 - 3.6027)
			Grade No. 3	91.511 - 91.515 (3.6028 - 3.6029)
			Grade No. 4	91.516 - 91.520 (3.6030 - 3.6031)
			Grade No. 5	91.521 - 91.525 (3.6032 - 3.6033)
			Grade No. 6	91.526 - 91.530 (3.6034 - 3.6035)
		Standard (except for No. 3 and 4 cylinders)	Grade No. 1	91.500 - 91.510 (3.6024 - 3.6027)
			Grade No. 2	91.511 - 91.520 (3.6028 - 3.6031)
			Grade No. 3	91.521 - 91.530 (3.6032 - 3.6035)
		Wear limit		0.20 (0.0079)
Out-of-round (X - Y)		Less than 0.015 (0.0006)		
Taper (A - B or A - C)		Less than 0.015 (0.0006)		
Main journal inner diameter	No. 1 main journal	Grade No. 0	66.645 - 66.651 (2.6238 - 2.6240)	
		Grade No. 1	66.651 - 66.657 (2.6240 - 2.6243)	
		Grade No. 2	66.657 - 66.663 (2.6243 - 2.6245)	
		Grade No. 3	66.663 - 66.669 (2.6245 - 2.6248)	
	No. 2, 3 and 4 main journals	Grade No. 0	66.645 - 66.654 (2.6238 - 2.6242)	
		Grade No. 1	66.654 - 66.663 (2.6242 - 2.6245)	
Grade No. 2		66.663 - 66.672 (2.6245 - 2.6249)		
Difference in inner diameter between cylinders		Standard Less than 0.05 (0.0020)		

SERVICE DATA AND SPECIFICATIONS (SDS)

Piston, Piston Ring and Piston Pin

Piston, Piston Ring and Piston Pin

NAEM0032

AVAILABLE PISTON

NAEM0032S01
Unit: mm (in)

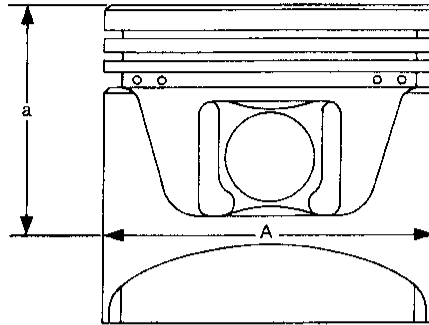

SEM882E

Piston skirt diameter "A"	Standard (for No. 3 and 4 cylinders)	Grade No. 2-1	91.480 - 91.485 (3.6016 - 3.6018)
		Grade No. 3-2	91.486 - 91.490 (3.6018 - 3.6020)
		Grade No. 3-3	91.491 - 91.495 (3.6020 - 3.6022)
		Grade No. 4-4	91.496 - 91.500 (3.6022 - 3.6024)
		Grade No. 4-5	91.501 - 91.505 (3.6024 - 3.6026)
		Grade No. 5-6	91.506 - 91.510 (3.6026 - 3.6027)
	Standard (except for No. 3 and 4 cylinders)	Grade No. 1	91.465 - 91.475 (3.6010 - 3.6014)
		Grade No. 2	91.476 - 91.485 (3.6014 - 3.6018)
		Grade No. 3	91.486 - 91.495 (3.6018 - 3.6022)
		0.25 (0.0098) oversize (Service)	91.715 - 91.745 (3.6108 - 3.6120)
		0.50 (0.0197) oversize (Service)	91.965 - 91.995 (3.6207 - 3.6218)
"a" dimension		49.0 (1.929)	
Piston pin hole diameter		20.969 - 20.981 (0.8255 - 0.8260)	
Piston clearance to cylinder block	Standard	For No. 3 and 4 cylinders	0.015 - 0.025 (0.0006 - 0.0010)
		Except for No. 3 and 4 cylinders	0.025 - 0.045 (0.0010 - 0.0018)

PISTON RING

NAEM0032S02
Unit: mm (in)

		Standard	Limit
Side clearance	Top	0.024 - 0.076 (0.0009 - 0.0030)	0.11 (0.0043)
	2nd	0.030 - 0.070 (0.0012 - 0.0028)	0.10 (0.004)
	Oil	0.015 - 0.185 (0.0006 - 0.0073)	—
Ring gap	Top	0.21 - 0.40 (0.0083 - 0.0157)	0.54 (0.0213)
	2nd	0.50 - 0.69 (0.0197 - 0.0272)	0.80 (0.0315)
	Oil (rail ring)	0.20 - 0.69 (0.0079 - 0.0272)	0.95 (0.0374)

SERVICE DATA AND SPECIFICATIONS (SDS)

Piston, Piston Ring and Piston Pin (Cont'd)

PISTON PIN

NAEM0032S03
Unit: mm (in)

Piston pin outer diameter	20.971 - 20.983 (0.8256 - 0.8261)
Interference fit of piston pin to piston	0 - 0.004 (0 - 0.0002)
Piston pin to connecting rod bushing clearance	0.005 - 0.017 (0.0002 - 0.0007)

Values measured at ambient temperature of 20°C (68°F)

Connecting Rod

NAEM0033
Unit: mm (in)

Center distance	154.1 - 154.2 (6.067 - 6.071)	
Bend, torsion [per 100 (3.94)]	Limit Bend: 0.15 (0.0059) Torsion: 0.30 (0.0118)	
Piston pin bushing inner diameter*	20.982 - 20.994 (0.8261 - 0.8265)	
Connecting rod big end inner diameter	53.000 - 53.013 (2.0866 - 2.0871)	
Side clearance	Standard	0.20 - 0.35 (0.0079 - 0.0138)
	Limit	0.40 (0.0157)

*After installing in connecting rod

Crankshaft

NAEM0034
Unit: mm (in)

Main journal dia. "Dm"	No. 1 main journal	Grade No. 0	62.969 - 62.975 (2.4791 - 2.4793)
		Grade No. 1	62.963 - 62.969 (2.4789 - 2.4791)
		Grade No. 2	62.957 - 62.963 (2.4786 - 2.4789)
	No. 2, 3 and 4 main journals	Grade No. 0	62.967 - 62.975 (2.4790 - 2.4793)
		Grade No. 1	62.959 - 62.967 (2.4787 - 2.4790)
		Grade No. 2	62.951 - 62.959 (2.4784 - 2.4787)
Pin journal dia. "Dp"		49.955 - 49.974 (1.9667 - 1.9675)	
Center distance "r"		41.5 (1.634)	
Out-of-round (X - Y)	Standard	Less than 0.005 (0.0002)	
Taper (A - B)	Standard	Less than 0.005 (0.0002)	
Runout [TIR]	Standard	Less than 0.025 (0.0010)	
	Limit	Less than 0.10 (0.0039)	
Free end play	Standard	0.050 - 0.170 (0.0020 - 0.0067)	
	Limit	0.30 (0.0118)	

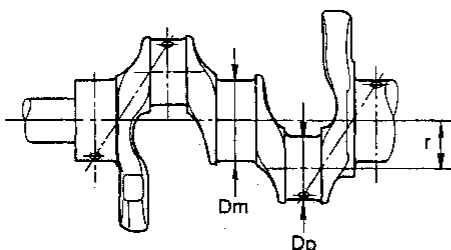

SEM645

Out-of-round (X - Y)
Taper (A - B)

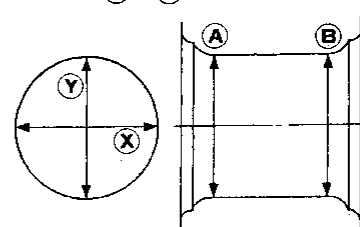

EM715

SERVICE DATA AND SPECIFICATIONS (SDS)

Available Main Bearing

Available Main Bearing

NAEM0035

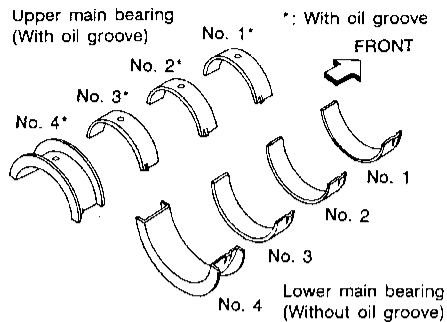

SEM327A

NO. 1 MAIN BEARING

NAEM0035S01

Grade number	Thickness "T" mm (in)	Width "W" mm (in)	Identification color (mark)
0	1.822 - 1.825 (0.0717 - 0.0719)	22.4 - 22.6 (0.882 - 0.890)	Black (A)
1	1.825 - 1.828 (0.0719 - 0.0720)		Brown (B)
2	1.828 - 1.831 (0.0720 - 0.0721)		Green (C)
3	1.831 - 1.834 (0.0721 - 0.0722)		Yellow (D)
4	1.834 - 1.837 (0.0722 - 0.0723)		Blue (E)
5	1.837 - 1.840 (0.0723 - 0.0724)		Pink (F)
6	1.843 - 1.846 (0.0726 - 0.0727)		Purple (G)

NO. 2 AND 3 MAIN BEARINGS

NAEM0035S02

Grade number	Thickness "T" mm (in)	Width "W" mm (in)	Identification color
0	1.817 - 1.821 (0.0715 - 0.0717)	18.9 - 19.1 (0.744 - 0.752)	Black
1	1.821 - 1.825 (0.0717 - 0.0719)		Brown
2	1.825 - 1.829 (0.0719 - 0.0720)		Green
3	1.829 - 1.833 (0.0720 - 0.0722)		Yellow
4	1.833 - 1.837 (0.0722 - 0.0723)		Blue

NO. 4 MAIN BEARING

NAEM0035S03

Grade number	Thickness "T" mm (in)	Identification color
0	1.817 - 1.821 (0.0715 - 0.0717)	Black
1	1.821 - 1.825 (0.0717 - 0.0719)	Brown
2	1.825 - 1.829 (0.0719 - 0.0720)	Green
3	1.829 - 1.833 (0.0720 - 0.0722)	Yellow
4	1.833 - 1.837 (0.0722 - 0.0723)	Blue

UNDER SIZE

NAEM0035S04
Unit: mm (in)

	Thickness "T"	Main journal diameter "Dm"
0.25 (0.0098)	1.948 - 1.956 (0.0767 - 0.0770)	Grind so that bearing clearance is the specified valve.

SERVICE DATA AND SPECIFICATIONS (SDS)

Available Connecting Rod Bearing

Available Connecting Rod Bearing

CONNECTING ROD BEARING UNDERSIZE

NAEM0006

NAEM0036S01
Unit: mm (in)

		Thickness	Crank pin journal diameter "Dp"
Standard		1.502 - 1.506 (0.0591 - 0.0593)	49.955 - 49.974 (1.9667 - 1.9675)
Undersize	0.08 (0.0031)	1.542 - 1.546 (0.0607 - 0.0609)	Grind so that bearing clearance is the specified value.
	0.12 (0.0047)	1.562 - 1.566 (0.0615 - 0.0617)	
	0.25 (0.0098)	1.627 - 1.631 (0.0641 - 0.0642)	

Miscellaneous Components

NAEM0037
Unit: mm (in)

Flywheel runout [TIR]	Less than 0.15 (0.0059)
Drive plate runout [TIR]	

BEARING CLEARANCE

NAEM0037S01
Unit: mm (in)

Main bearing clearance	Standard	0.028 - 0.055 (0.0011 - 0.0022)
	Limit	0.090 (0.0035)
Connecting rod bearing clearance	Standard	0.014 - 0.054 (0.0006 - 0.0021)
	Limit	0.090 (0.0035)

GI
MA
EM
LC
EC
FE
CL
MT
AT
TF
PD
AX
SU
BR
ST
RS
BT
HA
SC
EL
IDX