

SECTION

TF

CONTENTS

PREPARATION	2	DISASSEMBLY	13
Special Service Tools	2	REPAIR FOR COMPONENT PARTS	17
Commercial Service Tools	4	Mainshaft	17
DESCRIPTION	5	Front Drive Shaft	19
Cross-sectional View	5	Counter Gear.....	19
ON-VEHICLE SERVICE	6	Main Gear.....	20
Replacing Oil Seal.....	6	Front Case.....	21
Position Switch Check.....	7	Front Case Cover.....	22
REMOVAL AND INSTALLATION	8	Bearing Retainer.....	22
Removal.....	8	Rear Case.....	23
Installation.....	8	Shift Control Components	23
TRANSFER GEAR CONTROL	9	ASSEMBLY	25
MAJOR OVERHAUL	10	SERVICE DATA AND SPECIFICATIONS (SDS)	32
Case Components.....	10	General Specifications.....	32
Gear Components	11	Inspection and Adjustment	32
Shift Control Components	12		

PREPARATION

Special Service Tools

The actual shapes of Kent-Moore tools may differ from those of special service tools illustrated here.

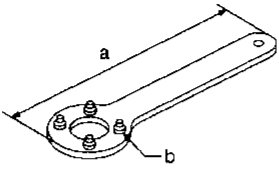
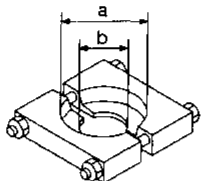
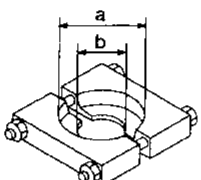
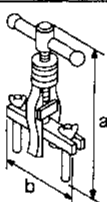
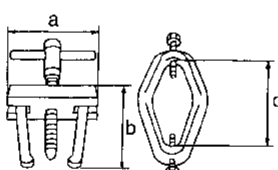
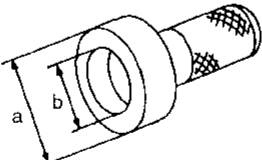
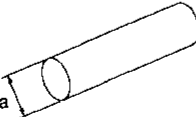
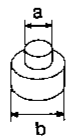
Tool number (Kent-Moore No.) Tool name	Description	
ST38060002 (J34311) Flange wrench	 <p style="text-align: center;">NT428</p>	Removing companion flange nut Installing companion flange nut a: 480 mm (18.90 in) b: Pitch dia.: 75 mm (2.95 in) Pin dia.: 10 mm (0.39 in)
ST30021000 (J22912-01) Puller	 <p style="text-align: center;">NT411</p>	Removing counter gear front bearing (Use with ST36710010) Removing L & H hub a: 110 mm (4.33 in) dia. b: 68 mm (2.68 in) dia.
ST30031000 (J22912-01) Puller	 <p style="text-align: center;">NT411</p>	Removing counter gear rear bearing (Use with ST36710010) a: 90 mm (3.54 in) dia. b: 50 mm (1.97 in) dia.
ST33290001 (J25810-A) Puller	 <p style="text-align: center;">NT414</p>	Removing center case oil seal Removing rear oil seal a: 250 mm (9.84 in) b: 160 mm (6.30 in)
ST33051001 (J22888) Puller	 <p style="text-align: center;">NT657</p>	Removing companion flange a: 135 mm (5.31 in) b: 100 mm (3.94 in) c: 130 mm (5.12 in)
ST30720000 ① (J25273) ② (J25405) Drift	 <p style="text-align: center;">NT658</p>	① Installing center case oil seal ② Installing rear oil seal a: 77 mm (3.03 in) dia. b: 55.5 mm (2.185 in) dia.
ST36710010 (—) Drift	 <p style="text-align: center;">NT063</p>	Removing counter gear front bearing (Use with ST30021000) Removing counter gear rear bearing (Use with ST30031000) a: 34.5 mm (1.358 in) dia.
ST33061000 (J8107-2) Drift	 <p style="text-align: center;">NT116</p>	Removing main gear bearing a: 28.5 mm (1.122 in) dia. b: 38 mm (1.50 in) dia.

PREPARATION

Special Service Tools (Cont'd)

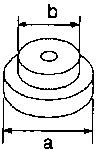
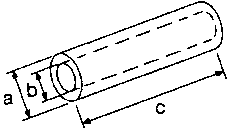
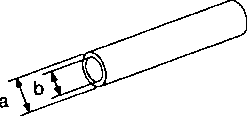
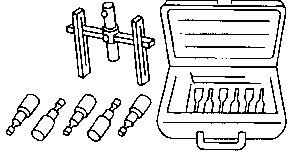
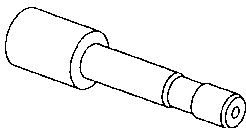
Tool number (Kent-Moore No.) Tool name	Description	
ST30613000 ① (J25742-3) ② (J34339) Drift	 <p style="text-align: center;">NT073</p>	GI MA EM
(J35864) Drift	 <p style="text-align: center;">NT117</p>	LC EC
(J26092) Drift	 <p style="text-align: center;">NT065</p>	FE CL
(J34291) Shim setting gauge set	 <p style="text-align: center;">NT101</p>	MT AT
(J34291-20) Plunger-shim setting gauge	 <p style="text-align: center;">NT118</p>	<div style="background-color: black; color: white; padding: 2px; text-align: center; font-weight: bold;">TF</div> PD FA

IDX

PREPARATION

Commercial Service Tools

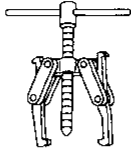
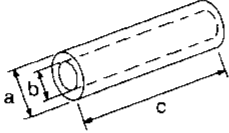
Tool name	Description
Puller	<div style="text-align: center;">  </div> <p style="text-align: center;">NT077</p> <ul style="list-style-type: none"> Removing front drive shaft front bearing Removing front drive shaft rear bearing Removing main gear bearing
Drift	<div style="text-align: center;">  </div> <p style="text-align: center;">NT117</p> <ul style="list-style-type: none"> ① Installing mainshaft rear bearing ② Installing L & H hub ① a: 50 mm (1.97 in) dia. b: 42 mm (1.65 in) dia. c: 180 mm (7.09 in) ② a: 60 mm (2.36 in) dia. b: 50 mm (1.97 in) dia. c: 60 mm (2.36 in)

DESCRIPTION

Cross-sectional View

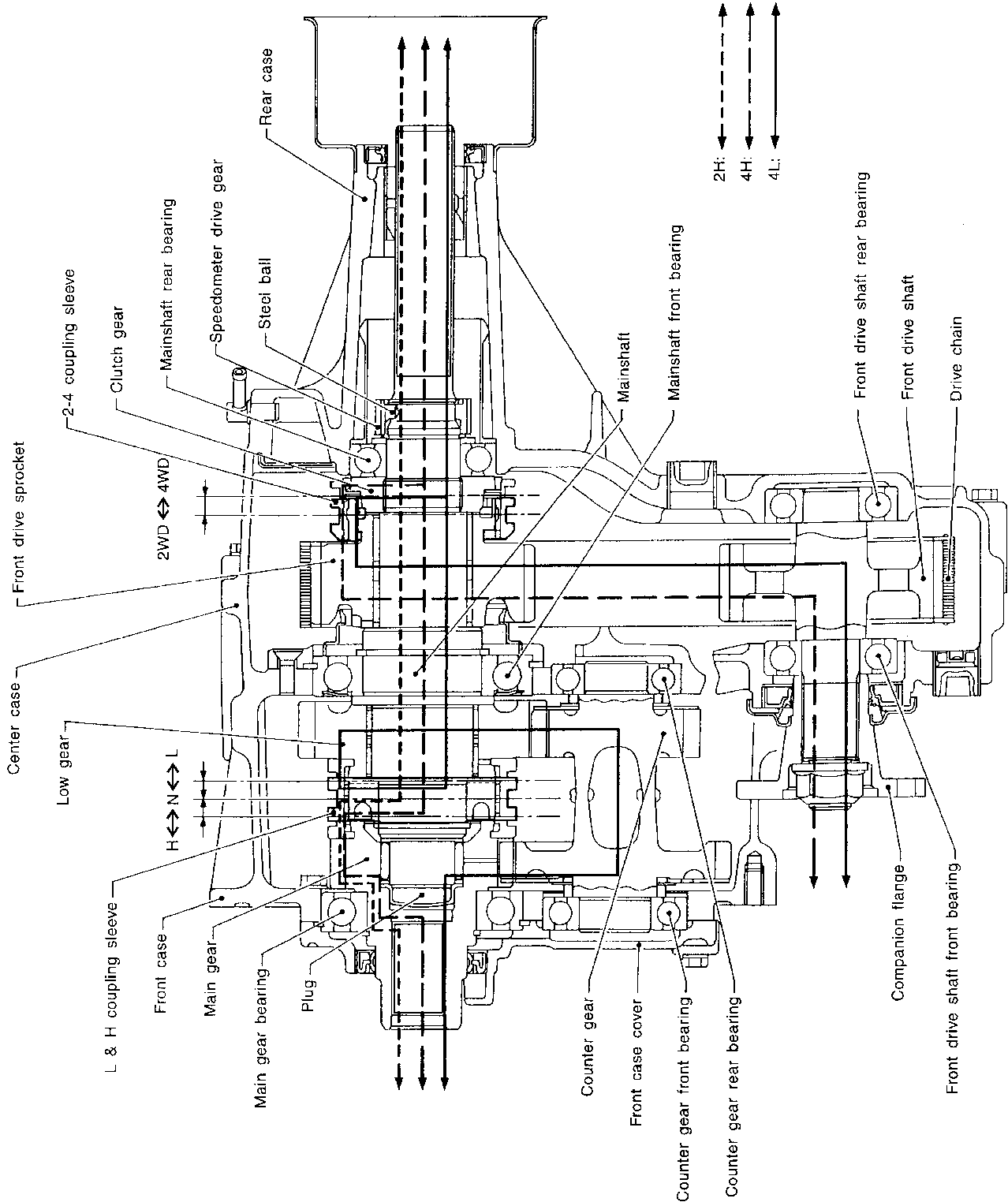

- GI
- MA
- EM
- LC
- EC
- FE
- CL
- MT
- AT
- TF**
- PD
- FA
- RA
- BR
- ST
- RS
- BT
- HA
- EL
- IDX

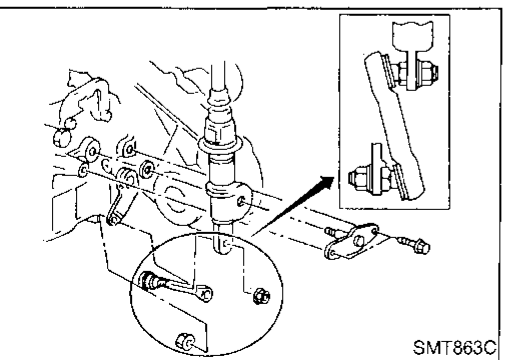
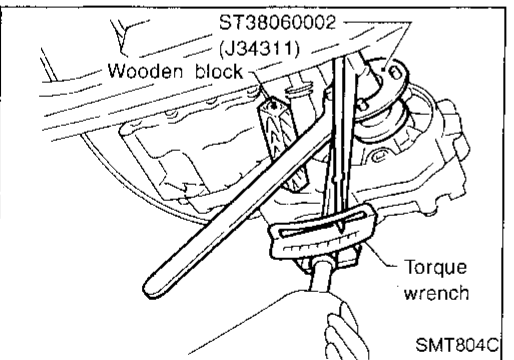
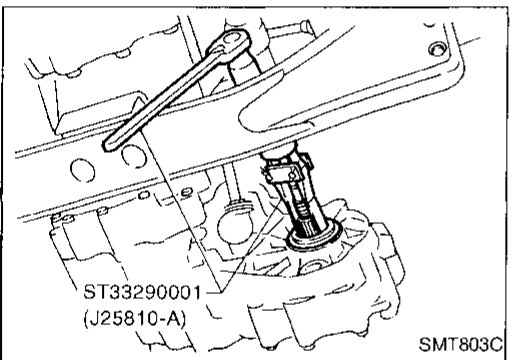
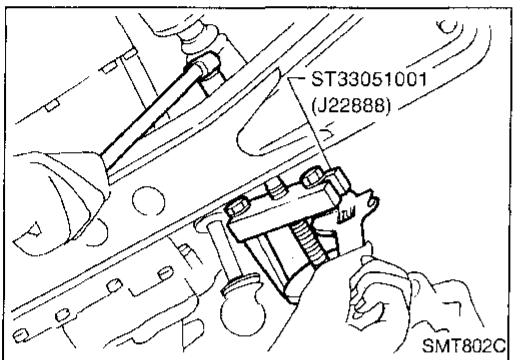
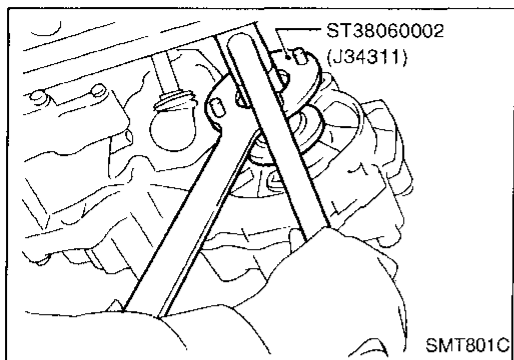

Replacing Oil Seal

CENTER CASE OIL SEAL

1. Remove exhaust front tube and heat insulator. Refer to "Removal", TF-8.
2. Remove front propeller shaft. Refer to PD section ("Removal and Installation", "PROPELLER SHAFT").
3. Remove companion flange nut.
4. Remove companion flange.
5. Remove center case oil seal.
6. Install center case oil seal.
 - **Before installing, apply multi-purpose grease to seal lip.**
7. Install companion flange.
8. Tighten nut to the specified torque.
9. Install front propeller shaft.

SHIFT SHAFT OIL SEAL

1. Remove front propeller shaft. Refer to PD section ("Removal and Installation", "PROPELLER SHAFT").
2. Remove companion flange. Refer to center case oil seal, TF-6.
3. Remove transfer control lever from transfer outer shift lever. Then remove outer shift lever.

ON-VEHICLE SERVICE

Replacing Oil Seal (Cont'd)

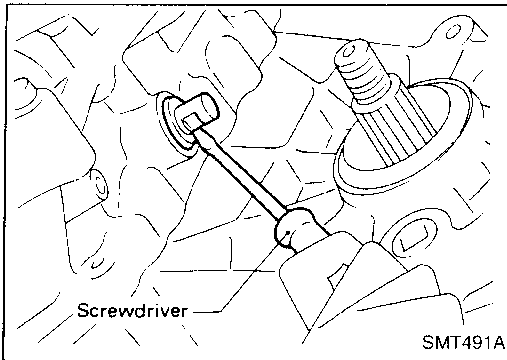

4. Remove shift shaft oil seal.
 - **Be careful not to damage cross shaft.**

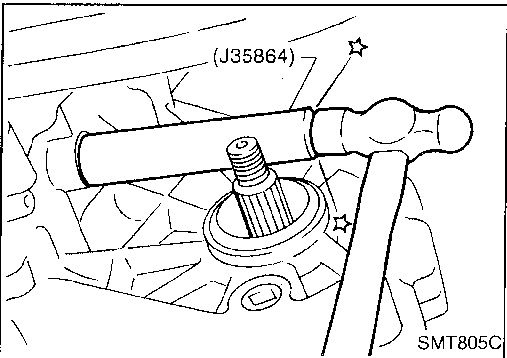

5. Install shift shaft oil seal.
 - **Before installing, apply multi-purpose grease to seal lip.**
6. Install transfer control linkage.
7. Install companion flange. Refer to center case oil seal, TF-6.
8. Install front propeller shaft.

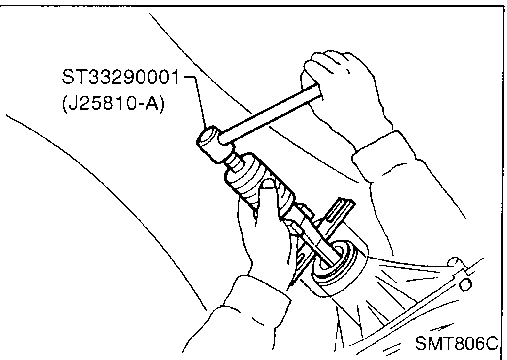

REAR OIL SEAL

1. Remove rear propeller shaft. Refer to PD section ("Removal and Installation", "PROPELLER SHAFT").
2. Remove rear oil seal.

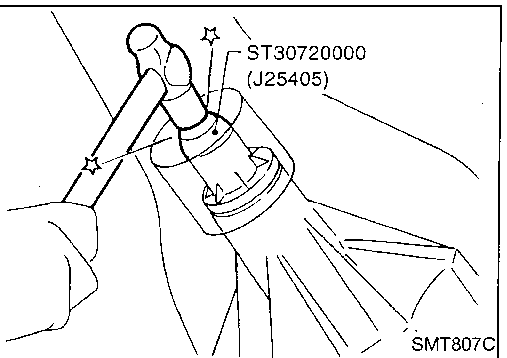

3. Install rear oil seal.
 - **Before installing apply multi-purpose grease to seal lip.**
4. Install rear propeller shaft.

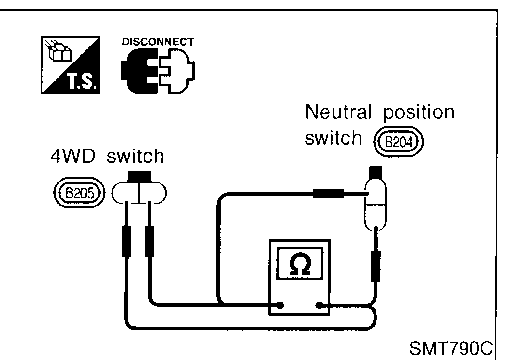

Position Switch Check

Switch	Gear position	Continuity
4WD switch	4WD	Yes
	Except 4WD	No
Neutral position switch	Neutral	Yes
	Except neutral	No

GI
MA
EM
LC
EC
FE
CL
MT
AT
TF
PD
FA
RA
BR
ST
RS
BT
HA
EL
DDX

REMOVAL AND INSTALLATION

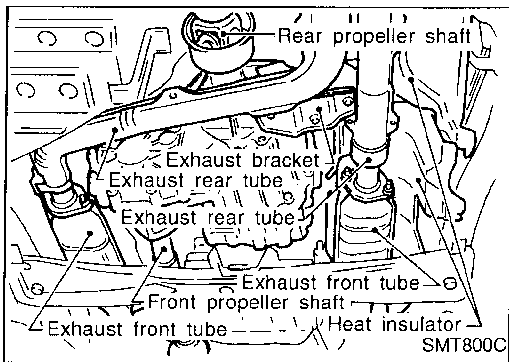

Removal

1. Drain oil from transfer and transmission.
2. Remove exhaust front and rear tubes. Refer to FE section ("EXHAUST SYSTEM").
3. Remove front and rear propeller shaft. Refer to PD section ("Removal and Installation", "PROPELLER SHAFT").
4. Insert plug into rear oil seal after removing propeller shaft.
 - **Be careful not to damage spline, sleeve yoke and rear oil seal, when removing propeller shaft.**
5. Disconnect neutral position and 4WD switch harness connectors.
6. Remove transfer control lever from transfer outer shift lever.
7. Remove transfer from transmission.

WARNING:

Support transfer while removing it.

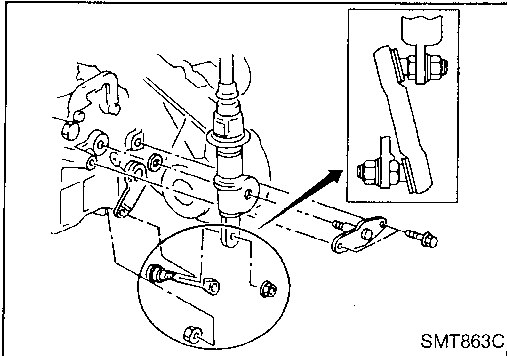

Installation

- Apply recommended sealant to mating surface to transmission. (M/T model only)

Recommended sealant:

Nissan genuine part (KP610-00250) or equivalent

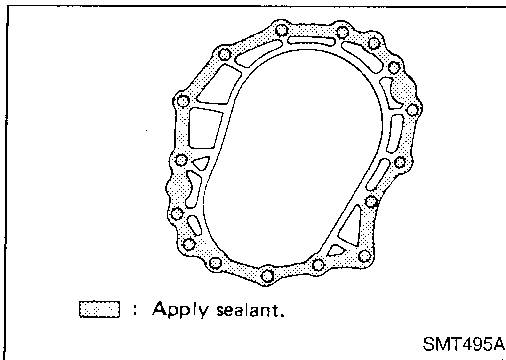

- Tighten bolts securing transfer.

M/T model

Bolt No.	Tightening torque N·m (kg·m, ft·lb)	ℓ mm (in)
①	31 - 41 (3.2 - 4.2, 23 - 30)	45 (1.77)
②	31 - 41 (3.2 - 4.2, 23 - 30)	60 (2.36)

A/T model

Bolt No.	Tightening torque N·m (kg·m, ft·lb)	ℓ mm (in)
①	31 - 41 (3.2 - 4.2, 23 - 30)	60 (2.36)
②	31 - 41 (3.2 - 4.2, 23 - 30)	60 (2.36)

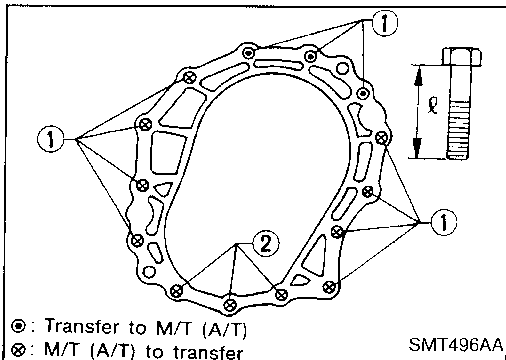

TRANSFER GEAR CONTROL

SEC. 333

: N·m (kg-m, in-lb)

: N·m (kg-m, ft-lb)

1 : Fill multi-purpose grease up.

2 : Apply multi-purpose grease.

*1 : Securely bend pawls during assembly.
Be careful not to damage boot.

*2 : Do not touch boot with a sharp-pointed
or a hard tool as it breaks easily.

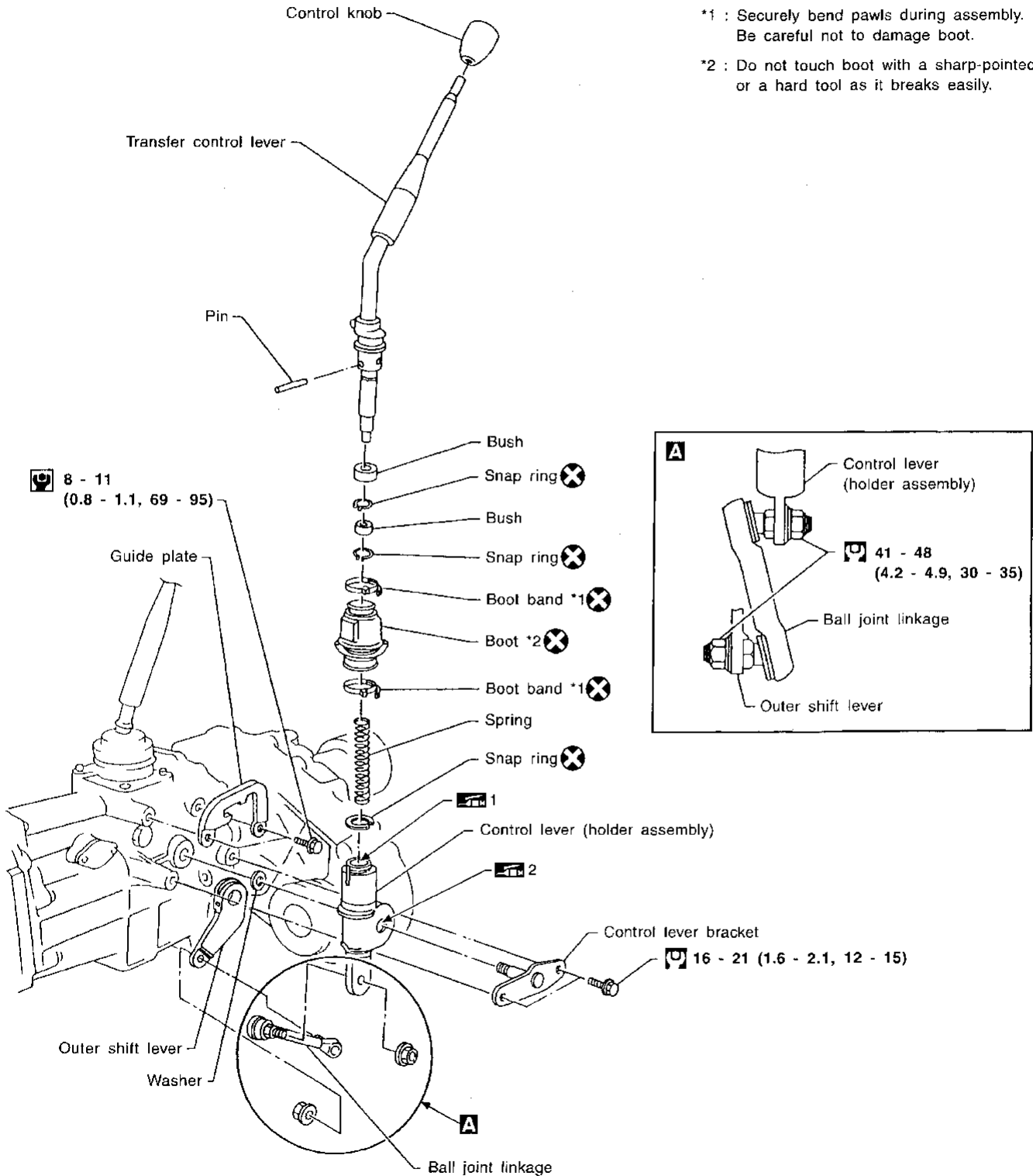

GI

MA

EM

LC

EC

FE

CL

MT

AT

TF

PD

FA

RA

BR

ST

RS

BT

HA

EL

IDX

Gear Components

SEC. 332

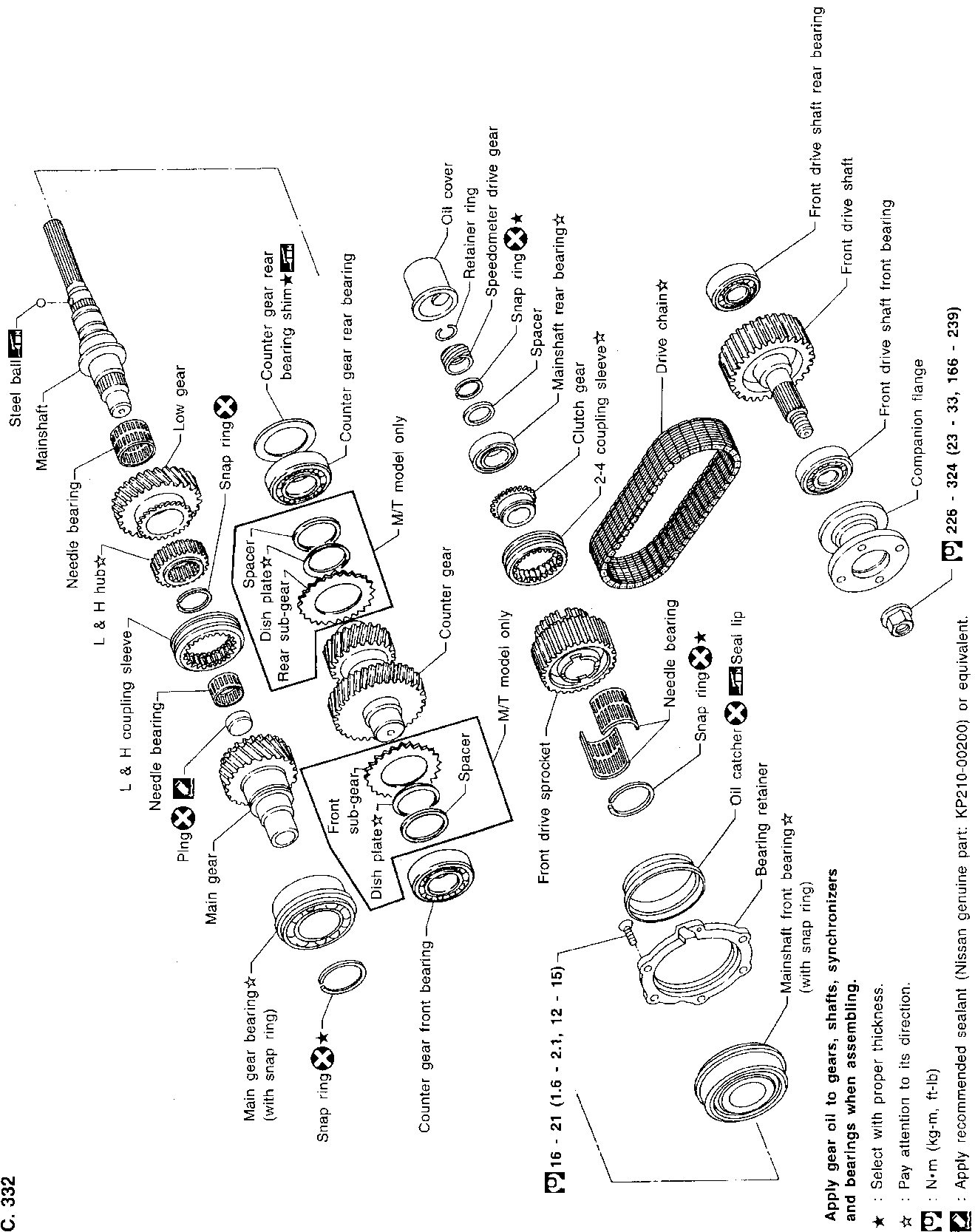

Apply gear oil to gears, shafts, synchronizers and bearings when assembling.

★ : Select with proper thickness.

☆ : Pay attention to its direction.

□ : N·m (kg-m, ft-lb)

⊗ : Apply recommended sealant (Nissan genuine part: KP210-00200) or equivalent.

226 - 324 (23 - 33, 166 - 239)

GI
MA
EV
LC
EC
FE
CL
MT
AT
TF
PD
FA
RA
BR
ST
RS
BT
HA
EL
DX

DISASSEMBLY

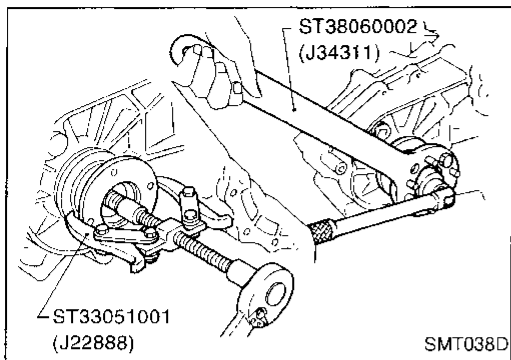

1. Remove nut of companion flange.
2. Remove companion flange.

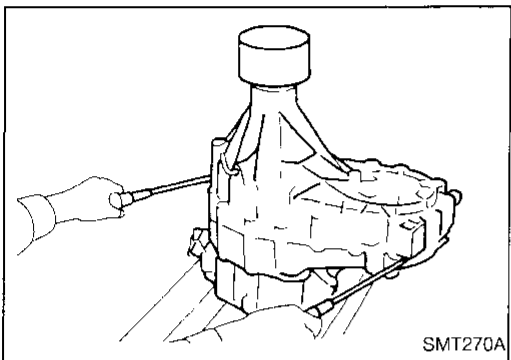

3. Remove 4WD switch.
4. Remove rear case.
 - Be careful not to damage the mating surface.

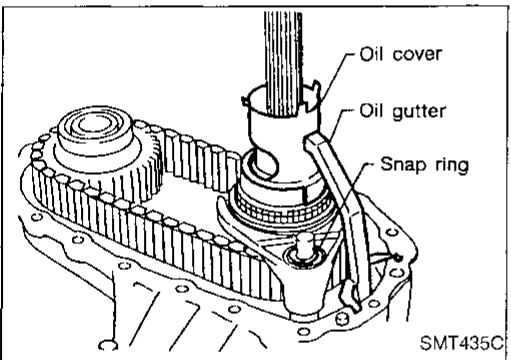

5. Remove oil cover and oil gutter.
6. Remove snap ring and retainer ring from 2-4 shift rod.

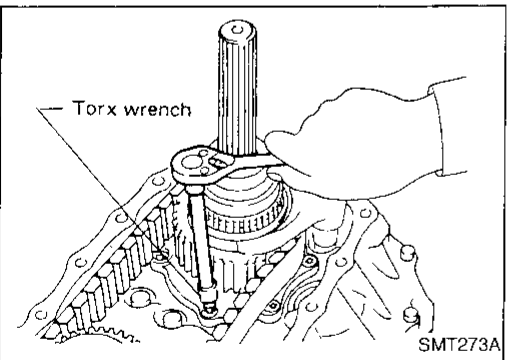

7. Remove bolts securing bearing retainer.
 - This step is necessary to remove mainshaft from center case.

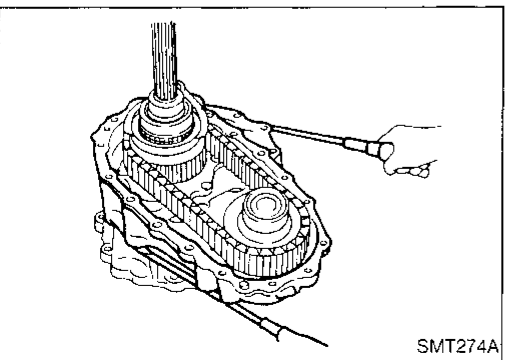

8. Remove bolts securing center case to front case and then separate center case and front case.

GI

MA

EM

LC

EC

FE

CL

MT

AT

TF

PD

FA

RA

BR

ST

RS

BT

HA

EL

IDX

DISASSEMBLY

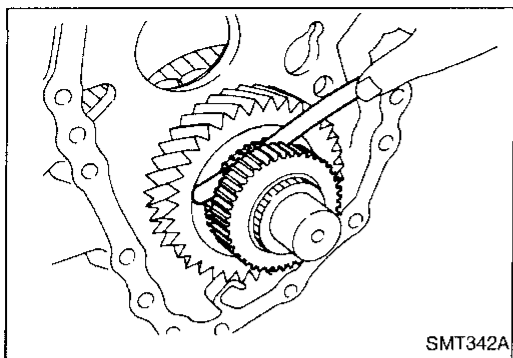

9. Measure end play of low gear.

Standard:

0.2 - 0.35 mm (0.0079 - 0.0138 in)

- If end play is beyond the maximum value, check low gear and L & H hub for wear.

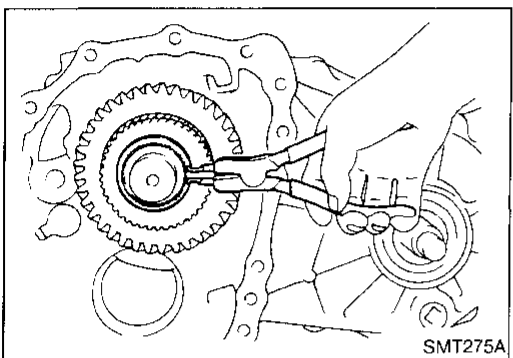

10. Disassemble center case assembly.

- a. Remove snap ring from mainshaft.

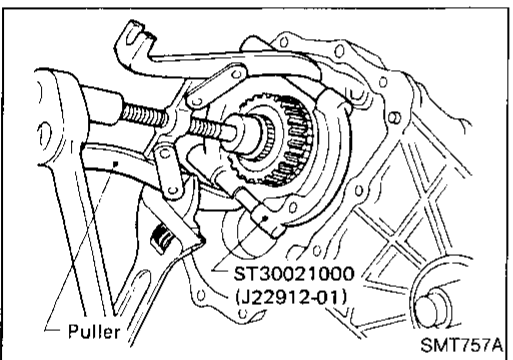

- b. Pull out low gear with L & H hub.

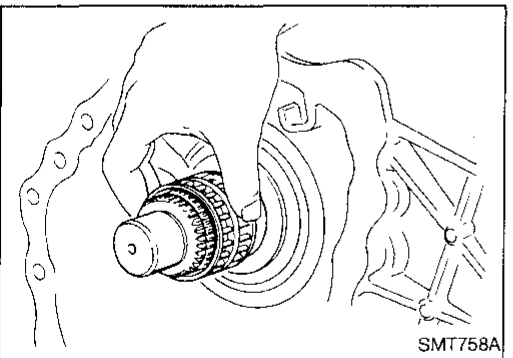

- c. Remove needle bearing of low gear.

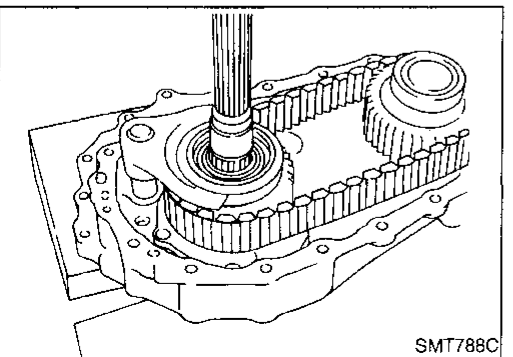

- d. Make sure of the direction of the drive chain before removing it. (It must be reinstalled in the same direction.)

DISASSEMBLY

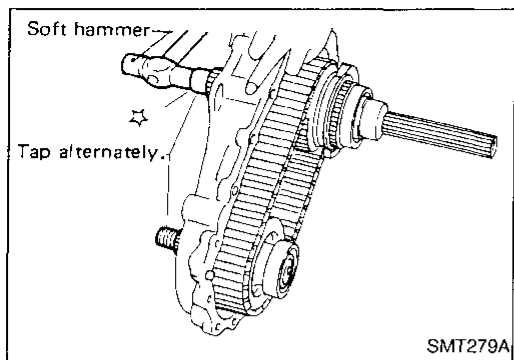

- e. Remove mainshaft, front drive and drive chain as a set by tapping front end of mainshaft and front drive shaft alternately.
- Be careful not to bend drive chain.

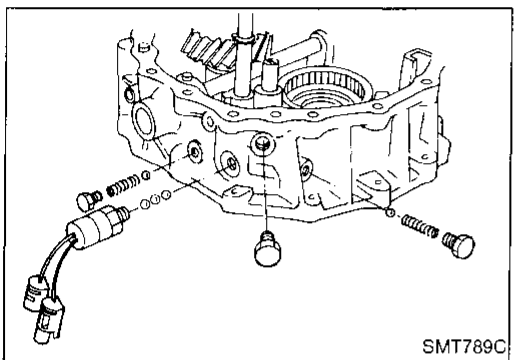

11. Disassemble front case assembly.
- a. Remove switch, plugs, check springs and check balls.

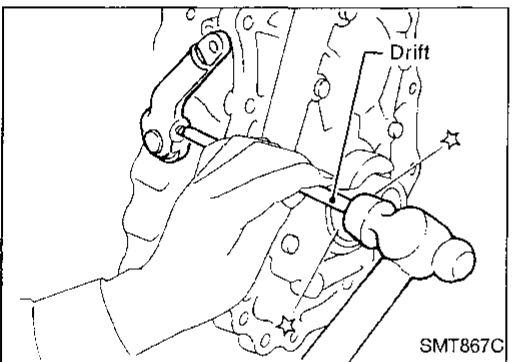

- b. Remove outer shift lever.

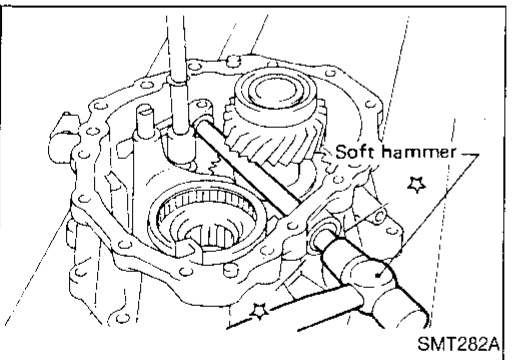

- c. Remove lock pin of inner shift lever and drive out cross shaft with plug.

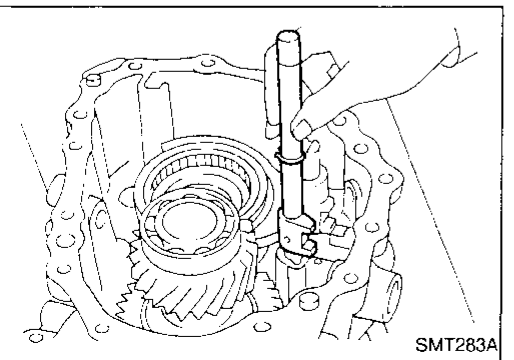

- d. Remove 2-4 shift rod.

GI

MA

EM

LC

EC

FE

CL

MT

AT

TF

PD

FA

RA

BR

ST

RS

BT

HA

EL

IDX

DISASSEMBLY

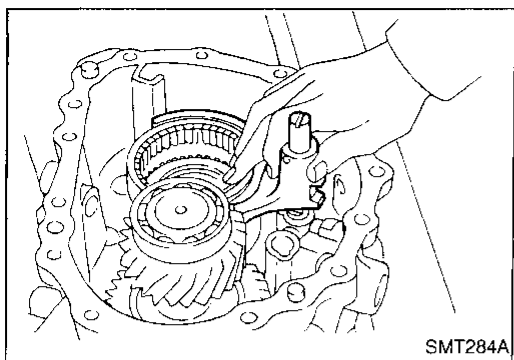

- e. Remove L & H shift rod and fork assembly with coupling sleeve.

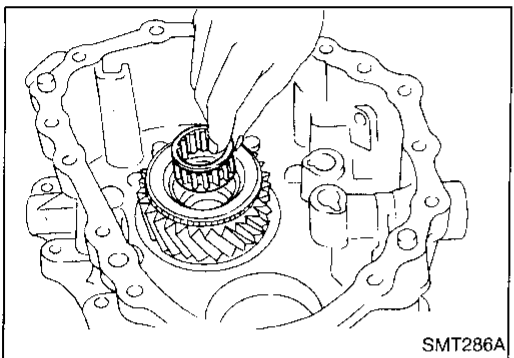

- f. Remove needle bearing from main gear.

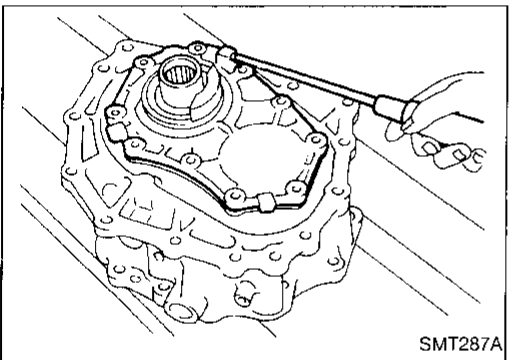

- g. Remove bolts securing front case cover and then remove case.

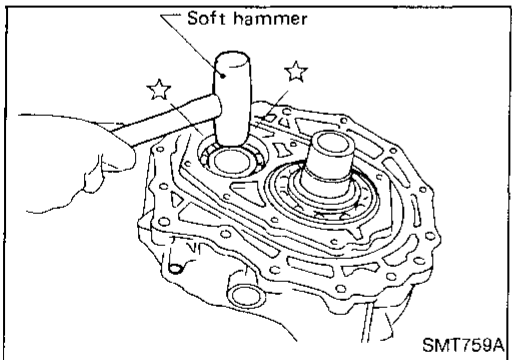

- h. Remove counter gear by tapping lightly.

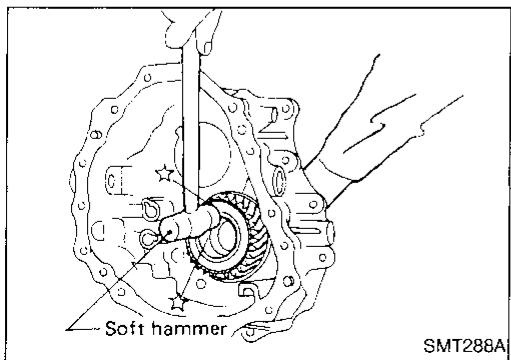

- i. Remove main gear by tapping lightly.

Mainshaft

DISASSEMBLY

1. Check end play of front drive sprocket.
 - Standard: 0.2 - 0.35 mm (0.0079 - 0.0138 in)
 - If end play is beyond the maximum value, check front drive sprocket and clutch gear for wear.

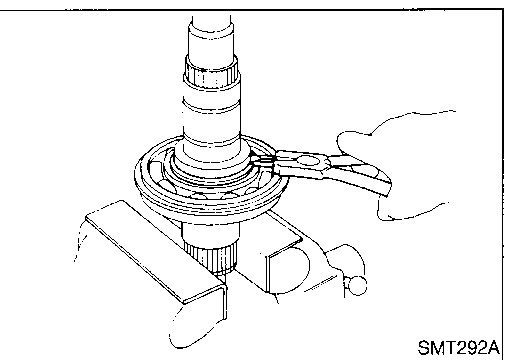
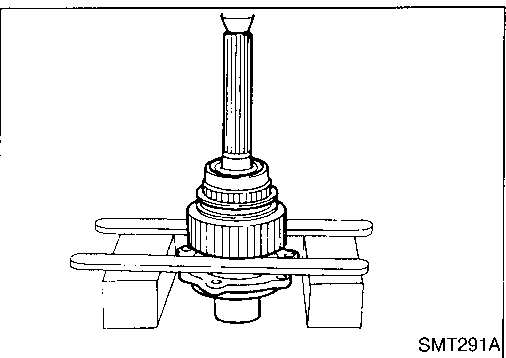
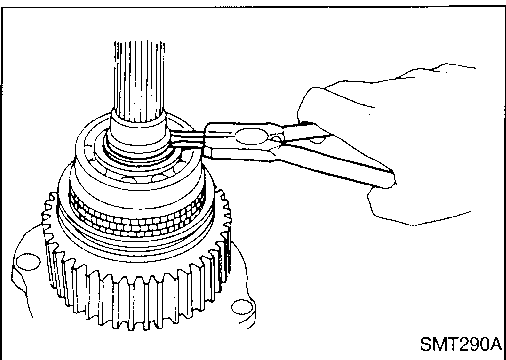
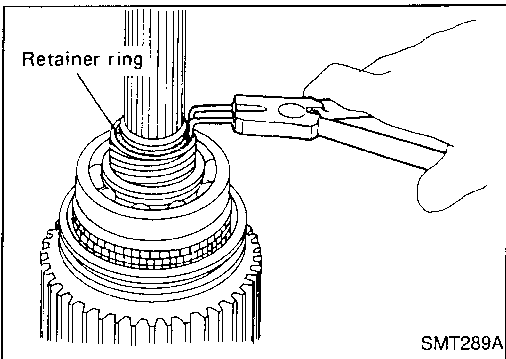
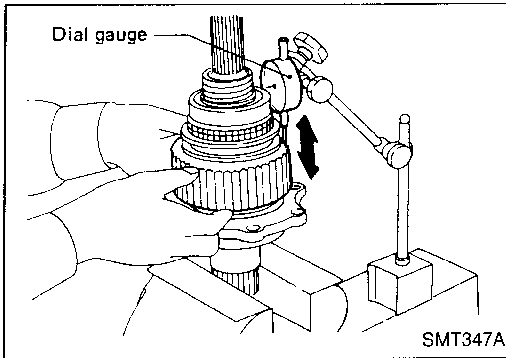

2. Remove retainer ring, speedometer drive gear and steel ball.
 - Be careful not to lose the steel ball.

3. Remove snap ring and spacer.

4. Press out front drive sprocket with mainshaft rear bearing and clutch gear together.
5. Remove needle bearing.

6. Remove bearing retainer and then remove snap ring.

GI

MA

EM

LC

EC

FE

CL

MT

AT

TF

PD

FA

RA

BR

ST

RS

BT

HA

EL

DX

REPAIR FOR COMPONENT PARTS

Mainshaft (Cont'd)

7. Press out mainshaft front bearing from mainshaft.

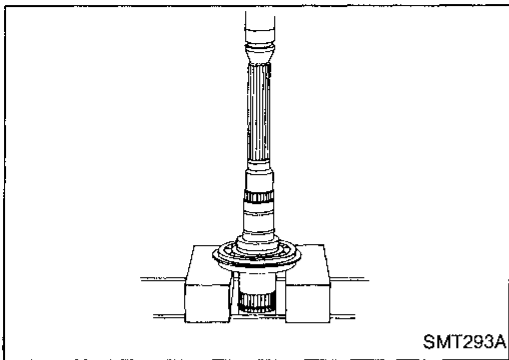

INSPECTION

Gear and shaft

- Check gears for excessive wear, chips or cracks.
- Check shaft for cracks, wear or bending.
- Check coupling sleeve for wear or damage.

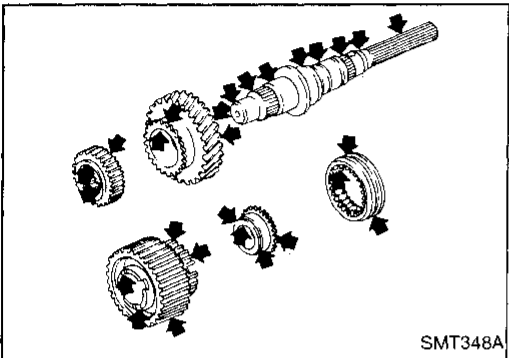

Bearing

- Make sure bearings roll freely and are free from noise, crack, pitting or wear.

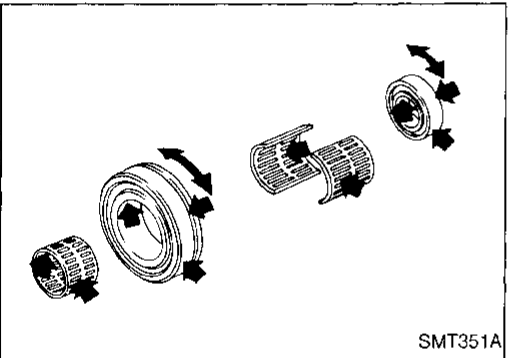

ASSEMBLY

1. Press mainshaft front bearing onto mainshaft.
 - Pay special attention to its direction.

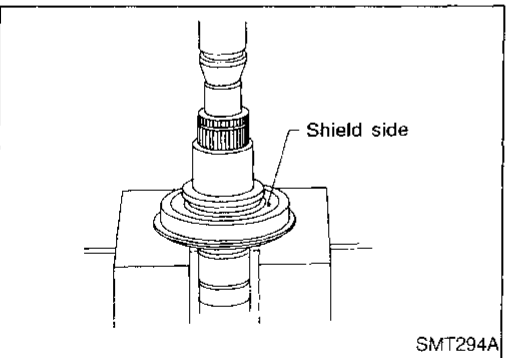

2. Select snap ring with proper thickness and install it.
 - Allowable clearance between snap ring and groove:
0 - 0.15 mm (0 - 0.0059 in)
 - Available snap ring for mainshaft front bearing:
Refer to SDS, TF-32.
3. Regarding to further procedures, refer to "ASSEMBLY", TF-25.

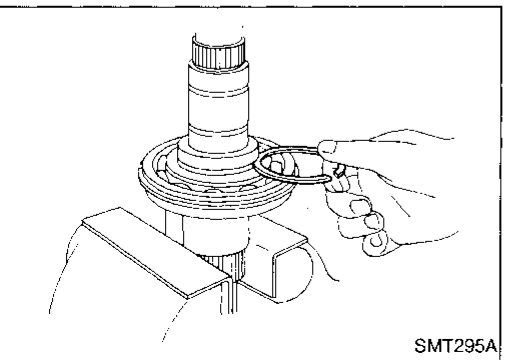

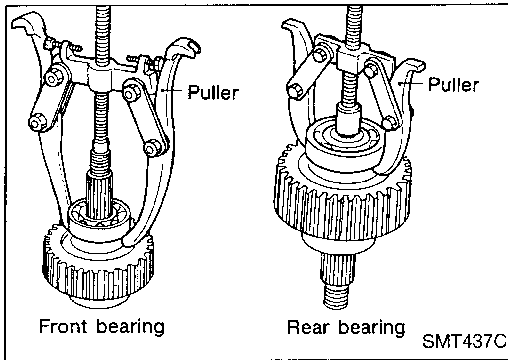

Front Drive Shaft

DISASSEMBLY

- Front drive shaft front bearing and rear bearing

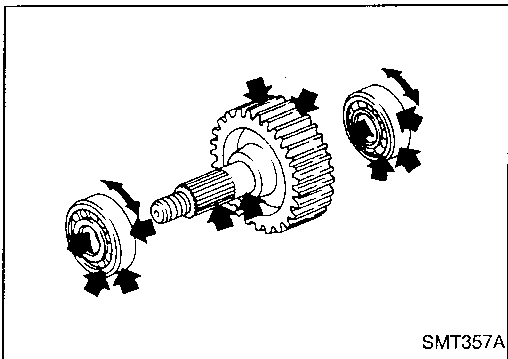

INSPECTION

Sprocket and shaft

- Check sprocket for excessive wear, chips or cracks.
- Check shaft for cracks or wear.

Bearing

- Make sure bearings roll freely and are free from noise, crack, pitting or wear.

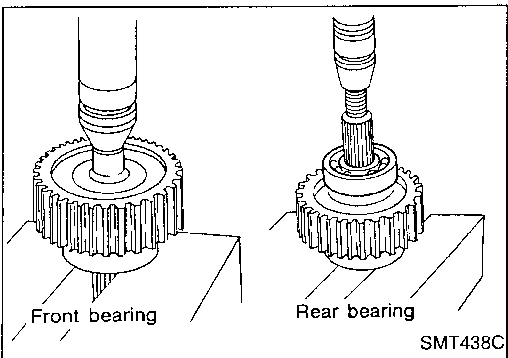

ASSEMBLY

- Press front drive shaft front bearing and rear bearing.

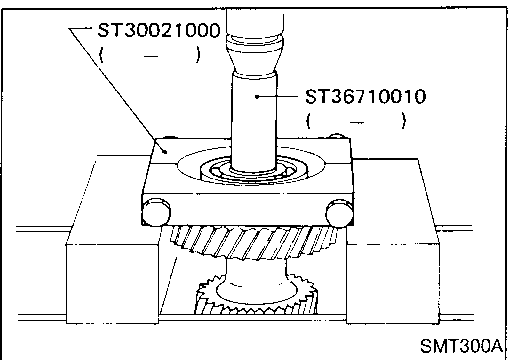

Counter Gear

DISASSEMBLY

1. Press out counter gear front bearing.
 - Remove front sub-gear, spacer and dish plate (M/T model only).

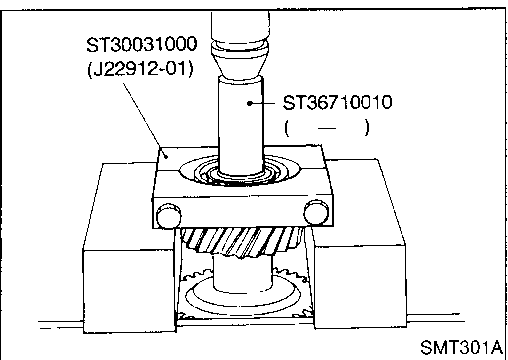

2. Press out counter gear rear bearing.
 - Remove rear sub-gear, spacer and dish plate (M/T model only).

GI

MA

EM

LC

EC

FE

CL

MT

AT

TF

PD

FA

RA

BR

ST

RS

BT

HA

EL

IDX

REPAIR FOR COMPONENT PARTS

Counter Gear (Cont'd)

INSPECTION

Gear and shaft

- Check gears for excessive wear, chips or cracks.
- Check shaft for cracks or wear.

Bearing

- Make sure bearings roll freely and are free from noise, crack, pitting or wear.

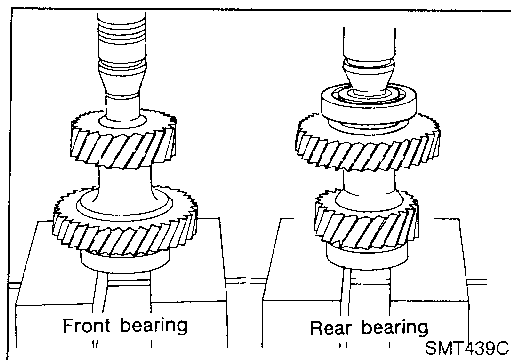
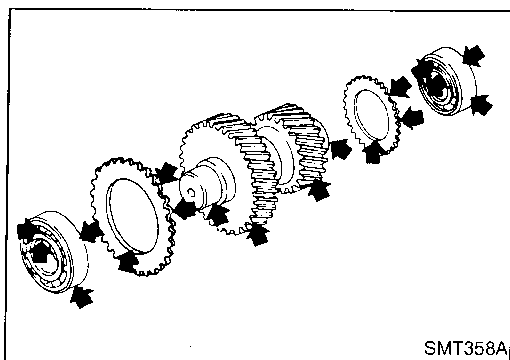

ASSEMBLY

1. Install front sub-gear, dish plate and spacer (M/T model only).
- Press on counter gear front bearing.
2. Install rear sub-gear, dish plate and spacer.
- Press on counter gear rear bearing (M/T model only).

Main Gear

DISASSEMBLY

Main gear bearing

1. Remove snap ring.
2. Pull out main gear bearing.

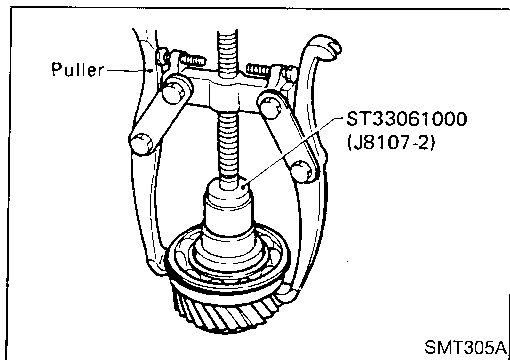
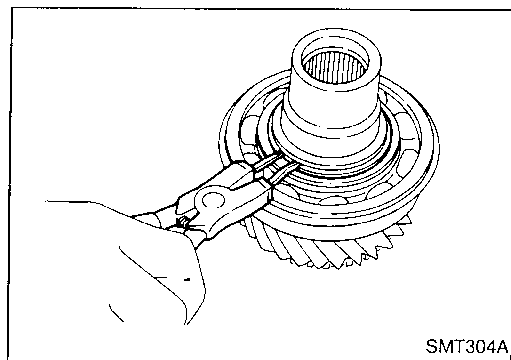

Plug

- Always replace it with new one whenever it is removed.

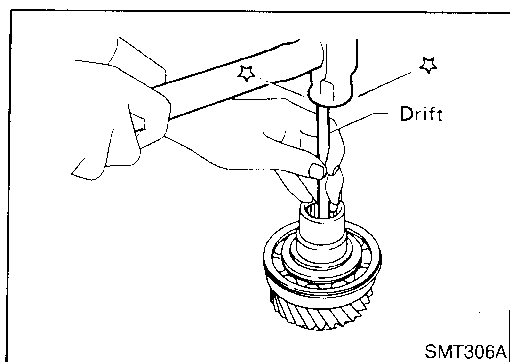

REPAIR FOR COMPONENT PARTS

Main Gear (Cont'd)

INSPECTION

Gear and shaft

- Check gears for excessive wear, chips or cracks.
- Check shaft for cracks or wear.

Bearing

- Make sure bearings roll freely and are free from noise, crack, pitting or wear.

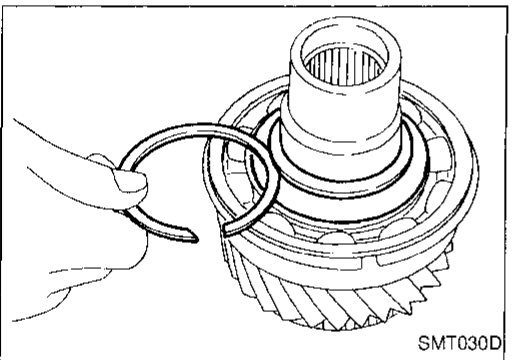
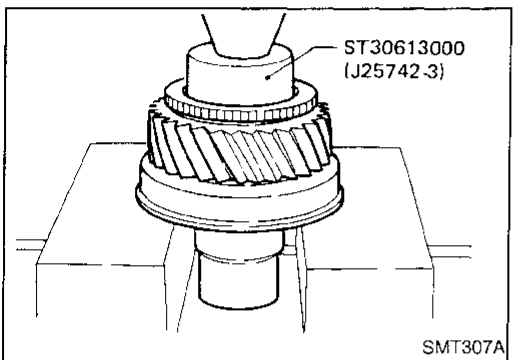
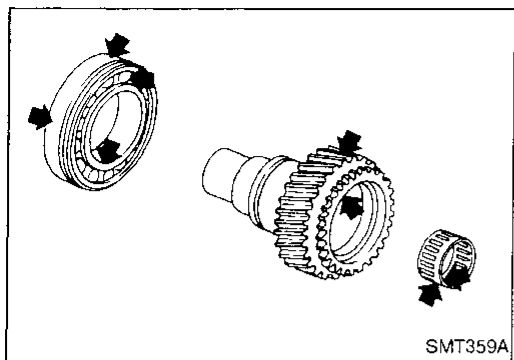

2. Select snap ring with proper thickness and install it.
Allowable clearance between snap ring and groove:
0 - 0.15 mm (0 - 0.0059 in)
Available snap ring for main gear bearing:
Refer to SDS, TF-32.

Plug

- Apply sealant to plug and install it.

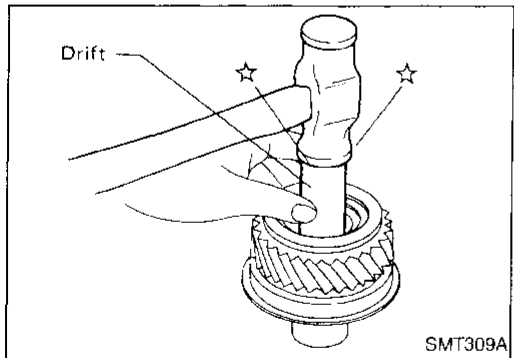

Front Case

SHIFT SHAFT OIL SEAL

Removal

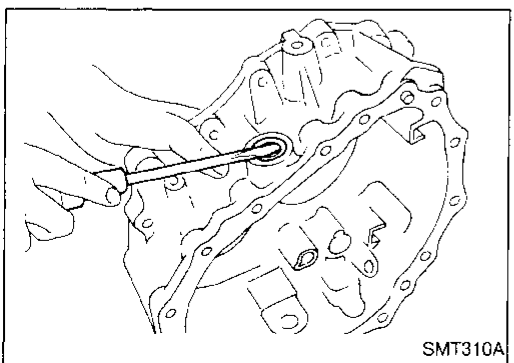

GI

MA

EM

LC

EC

FE

CL

MT

AT

TF

PD

FA

RA

BR

ST

RS

BT

HA

EL

IDX

REPAIR FOR COMPONENT PARTS

Front Case (Cont'd)

Installation

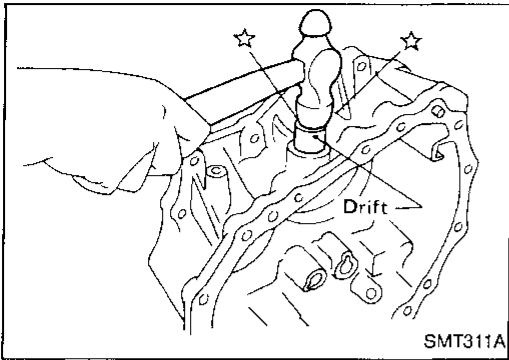

Front Case Cover

COVER OIL SEAL

Removal

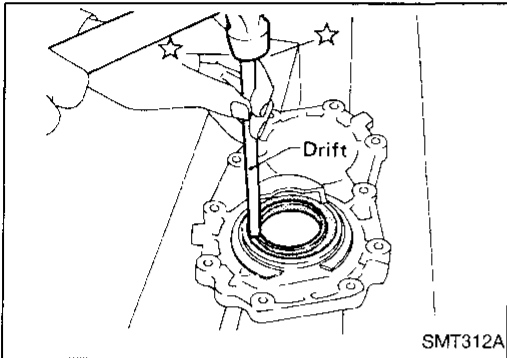

Installation

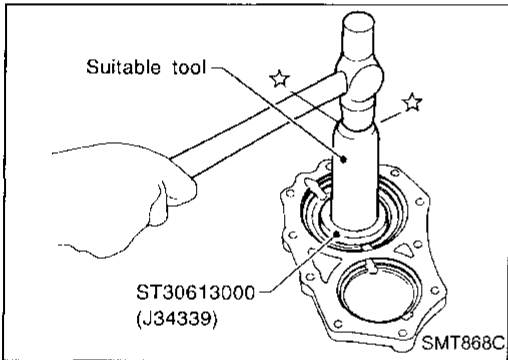

Bearing Retainer

OIL CATCHER

Removal

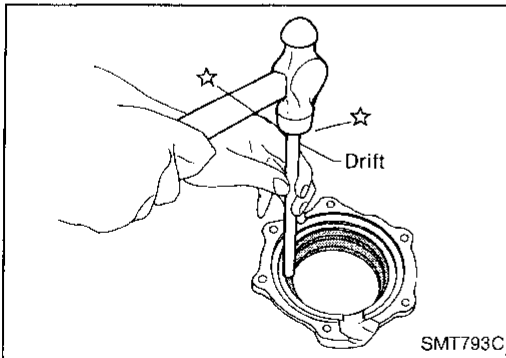

Installation

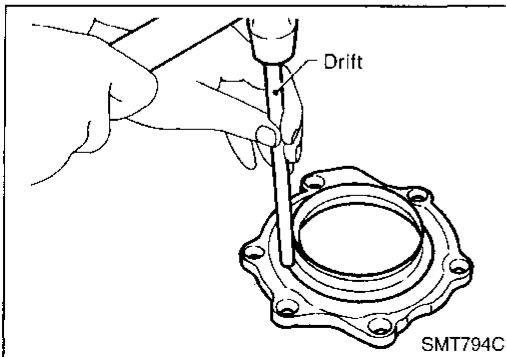

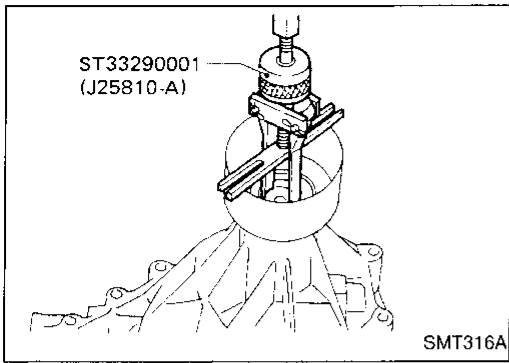

Rear Case REAR OIL SEAL Removal

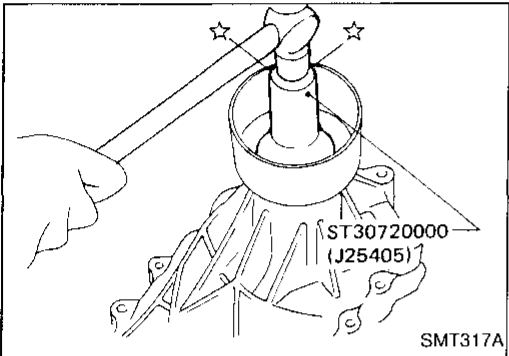

Installation

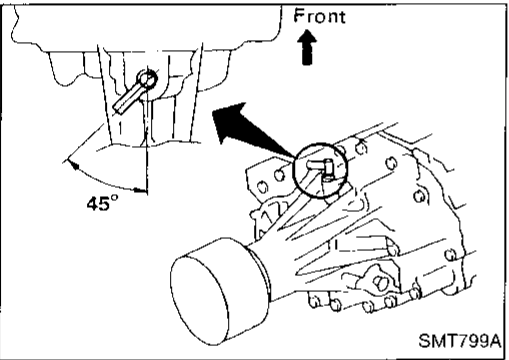

AIR BREATHER

- Install as shown in illustration.

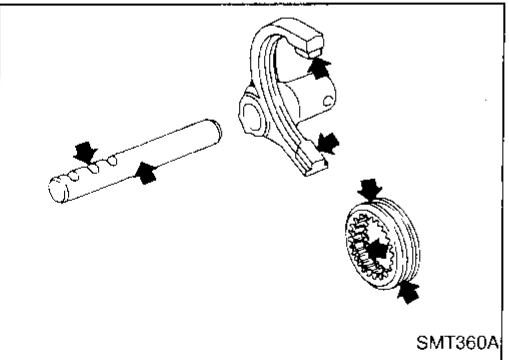

Shift Control Components

INSPECTION

- Check contact surface and sliding surface for wear, scratches, projections or other faulty conditions.

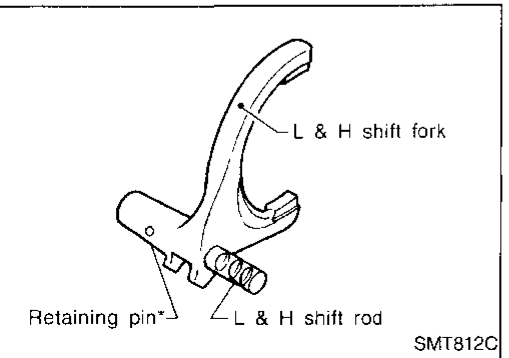

L & H SHIFT ROD & FORK

- Assemble as shown in illustration.

* Retaining pin is the same size as the one for 2-4 shift rod.

GI
MA
EM
LC
EC
FE
CL
MT
AT
TF
PD
FA
RA
BR
ST
RS
BT
HA
EL
ICX

REPAIR FOR COMPONENT PARTS

Shift Control Components (Cont'd)

2-4 SHIFT ROD & FORK

- Assemble as shown in illustration.

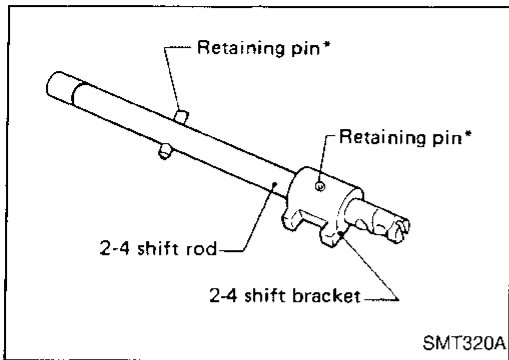

* Retaining pins are the same size.

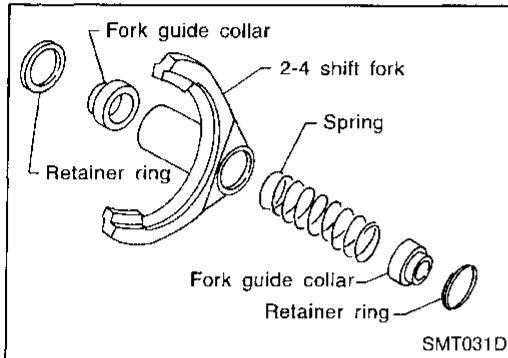

- Pay special attention to the direction of fork guide collar.

ASSEMBLY

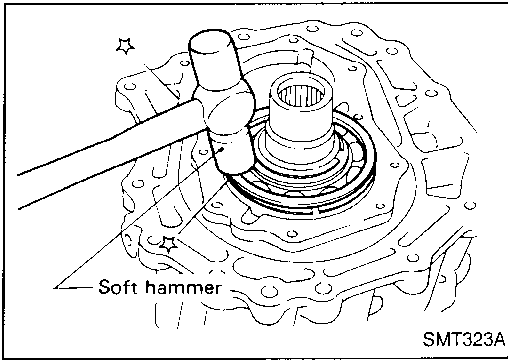

1. Assemble front case.
 - a. Install main gear assembly by tapping lightly.

GI

MA

EM

LC

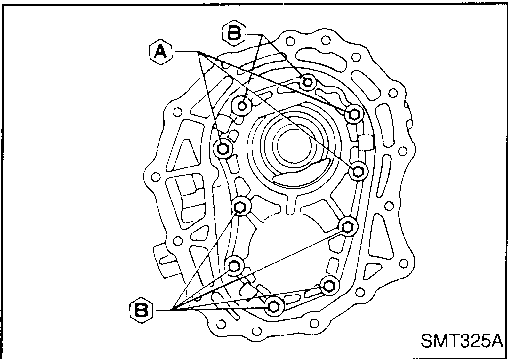

- b. Apply sealant to the mating surface and bolts of front case cover and install it on front case.

EC

- These ten bolts should be coated with sealant.

- Tightening torque

A : 16 - 21 N·m
(1.6 - 2.1 kg-m, 12 - 15 ft-lb)

B : 19 - 24 N·m
(1.9 - 2.4 kg-m, 14 - 17 ft-lb)

FE

CL

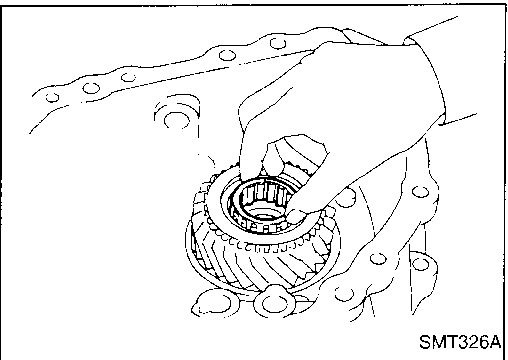

- c. Apply gear oil to needle bearing and install it into main gear.

AT

TF

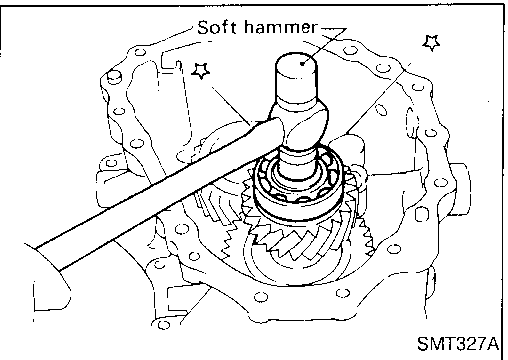

- d. Install counter gear assembly by tapping lightly.

PD

FA

RA

BR

ST

RS

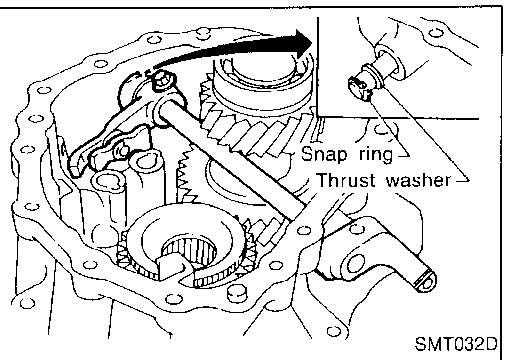

- e. Install cross shaft and inner shift lever.

BT

- When replacing cross shaft, outer shift lever or lock pin of outer shift lever, replace them as a set.

HA

EL

IDX

ASSEMBLY

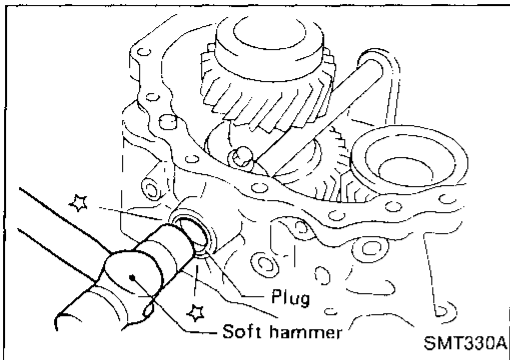

f. Apply sealant to plug and install it into front case.

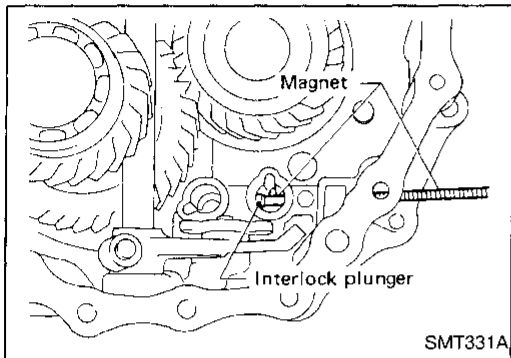

g. Insert interlock plunger into front case.

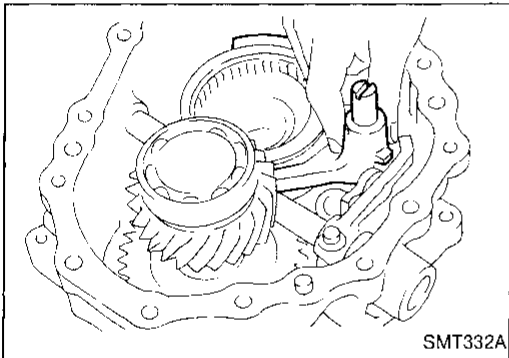

h. Install L & H shift rod and fork assembly with coupling sleeve.

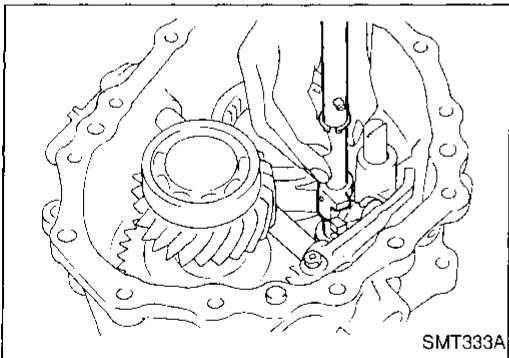

i. Install 2-4 shift rod.

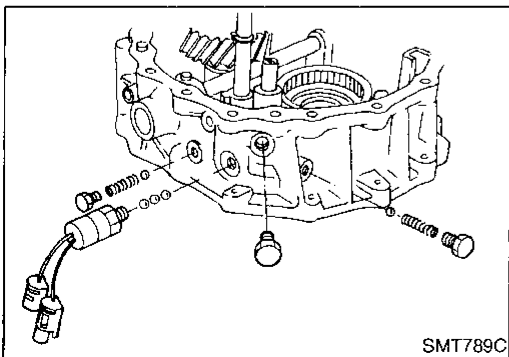

j. Install switches, check balls, check springs and plugs.
● **Apply sealant to switches and plugs.**

ASSEMBLY

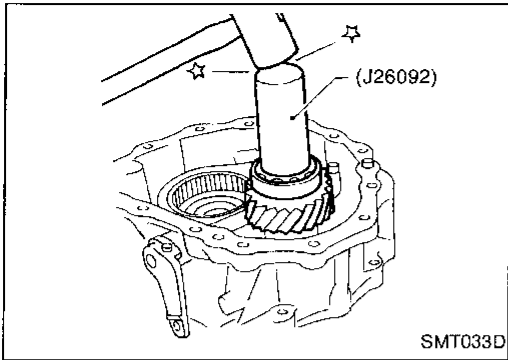

2. Select counter gear rear bearing shim.
 - a. Seat counter gear assembly.

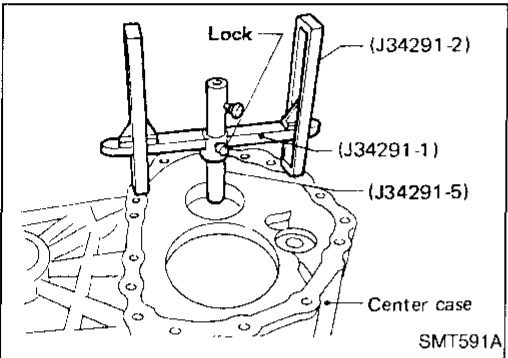

- b. Place J34291-1 (bridge), J34291-2 (legs) and J34291-5 (gauging cylinder) on machined surface of center case and allow gauging cylinder to rest on top outer portion of counter gear rear bearing. Lock gauging cylinder in place.

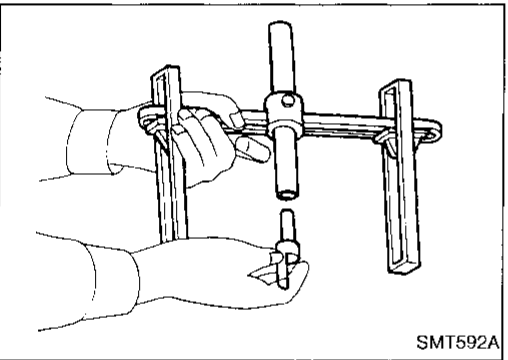

- c. Insert J34291-20 (gauging plunger) into J34291-5 (gauging cylinder).

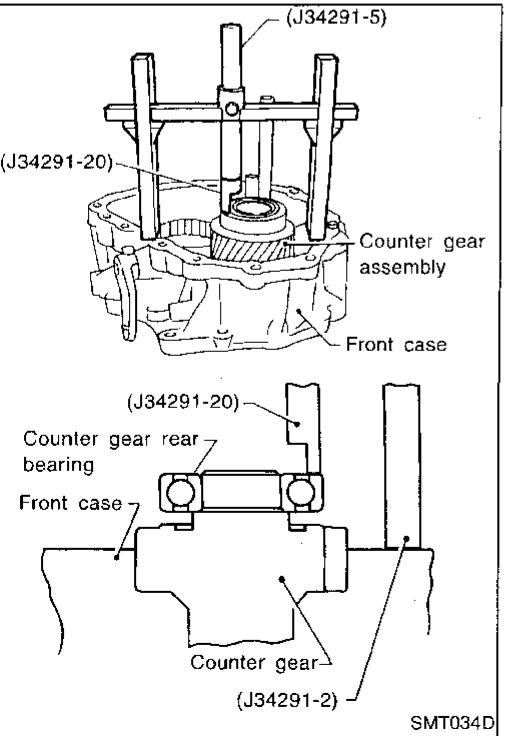

- d. Place bridge, legs, gauging cylinder and gauging plunger onto machined surface of front case assembly, and allow gauging plunger to drop until it contacts counter gear rear bearing matting surface.

GI

MA

EM

LC

EC

FE

CL

MT

AT

TF

PD

FA

RA

BR

ST

RS

BT

HA

EL

IDX

ASSEMBLY

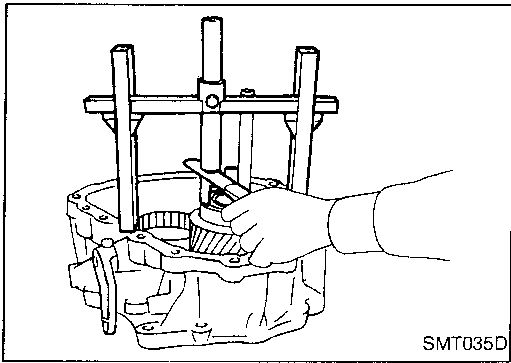

- e. Lock gauging plunger in place and use feeler gauge to measure gap between gauging cylinder and gauging plunger.
- f. Use measured distance and following chart to select correct shim.

Counter gear end play:
0 - 0.2 mm (0 - 0.008 in)

Counter gear rear bearing shim:
Refer to SDS, TF-32.

- g. Select counter gear rear bearing shim.

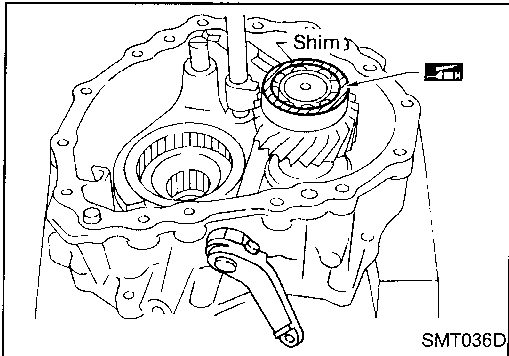

3. Place suitable shim on counter gear rear bearing with grease.
4. Apply gear oil to each part in front case.

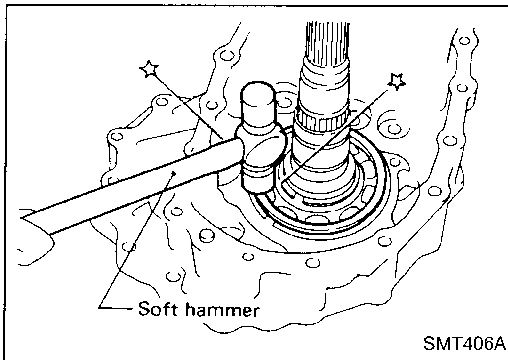

5. Assemble center case assembly.
 - a. Install mainshaft on center case by tapping lightly.
- **Apply gear oil to mainshaft front bearing.**

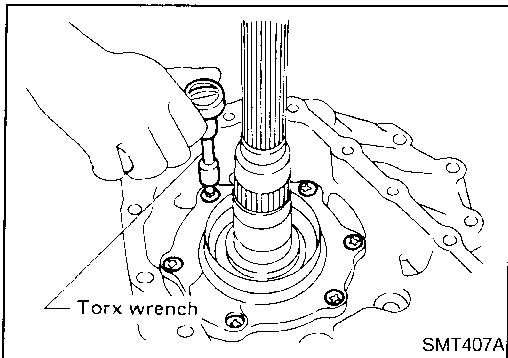

- b. Install bearing retainer.

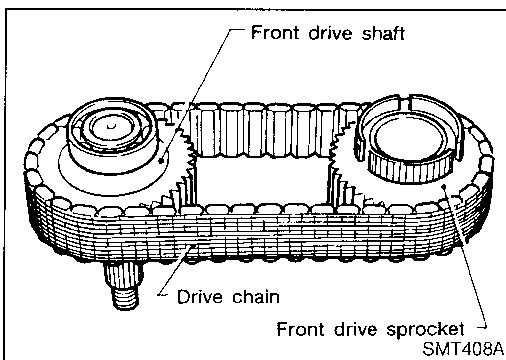

- c. Put drive chain onto the front drive sprocket and front drive shaft, and then put them in center case.

ASSEMBLY

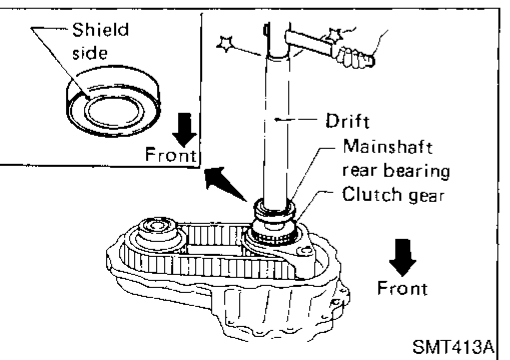
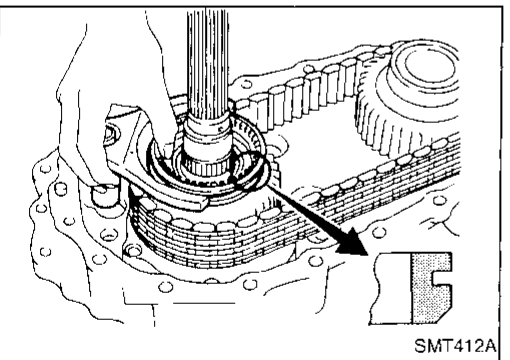
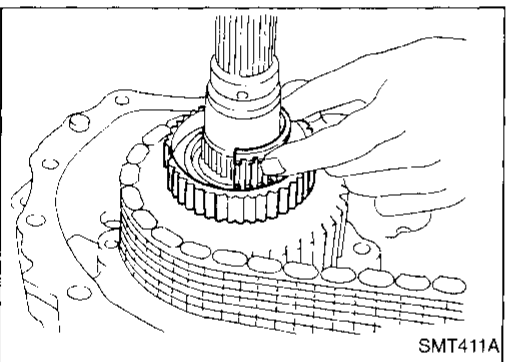
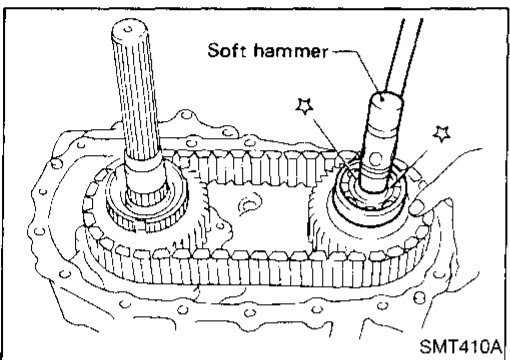
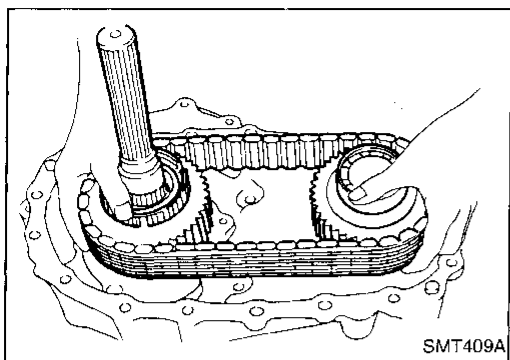

- d. Install front drive shaft by tapping lightly.
- **Make sure shafts are lined up in the case.**

- e. Apply gear oil to needle bearings and install them into front drive sprocket.
- **These needle bearings will be installed move easily if front drive sprocket is rotated while installing them.**

- f. Install 2-4 coupling sleeve with 2-4 shift fork.
- **Pay special attention to direction of coupling sleeve.**

- g. Install clutch gear and mainshaft rear bearing.
- **Place wooden block under mainshaft in order to protect mainshaft front bearing.**

GI

MA

EM

LC

EC

FE

CL

MT

AT

TF

PD

FA

RA

BR

ST

RS

BT

HA

EL

IDX

ASSEMBLY

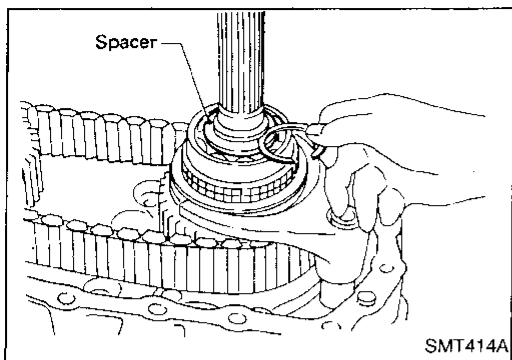

- h. Install spacer.
- i. Select snap ring with proper thickness and install it.
Allowable clearance between snap ring and groove:
 0 - 0.15 mm (0 - 0.0059 in)
Available snap ring for mainshaft rear bearing:
 Refer to SDS, TF-32.

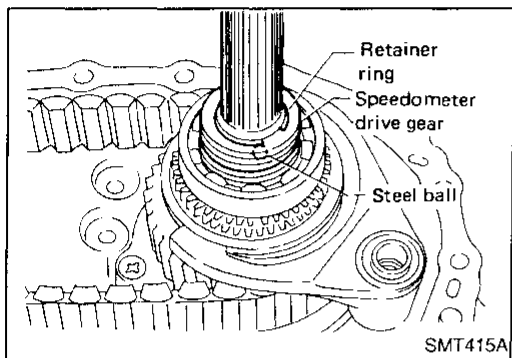

- j. Install steel ball, speedometer drive gear and retainer ring.
 - **Steel ball is the smallest of check balls for this unit.**

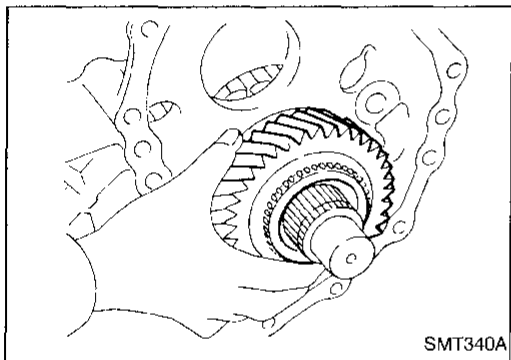

- k. Install low gear and its bearing to mainshaft.
 - **Apply gear oil to needle bearing.**

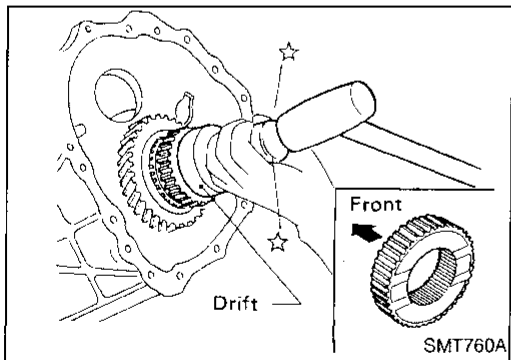

- l. Install L & H hub and snap ring to mainshaft.
 - **Pay special attention to direction of L & H hub.**

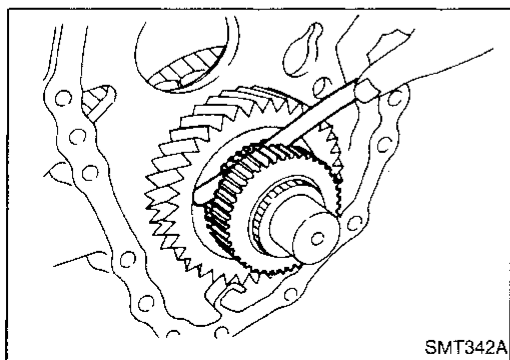

- m. Measure end play of low gear.
Standard: 0.2 - 0.35 mm (0.0079 - 0.0138 in)

ASSEMBLY

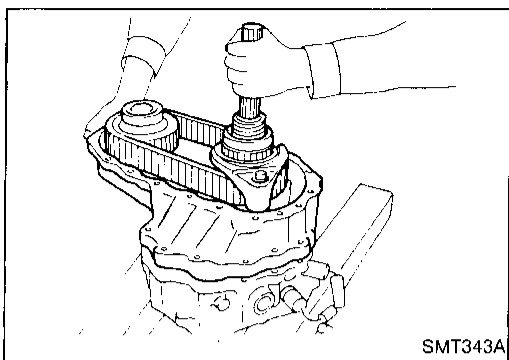

6. Apply sealant to mating surface and put center case assembly onto front case and tighten bolts.

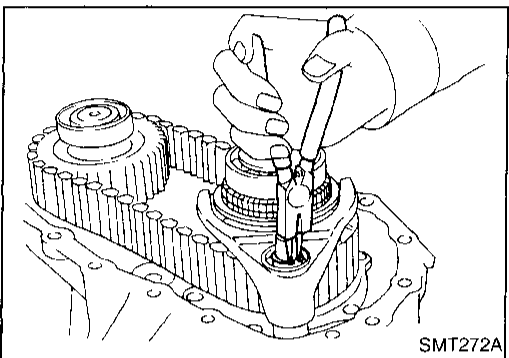

7. Install snap ring to 2-4 shift rod.

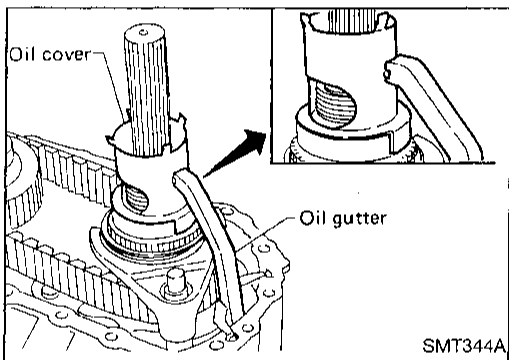

8. Install oil gutter and oil cover.
9. Apply gear oil to each part in center case.

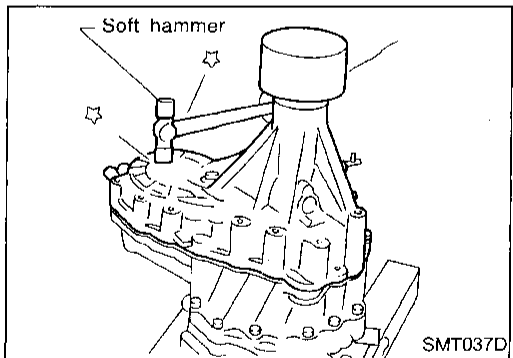

10. Apply sealant to mating surface and install rear case on center case.
 11. Install 4WD switch.
- Apply sealant to thread of switch.

GI

MA

EM

LC

EC

FE

CL

MT

AT

TF

PD

FA

RA

BR

ST

RS

BT

HA

EL

IDX

SERVICE DATA AND SPECIFICATIONS (SDS)

General Specifications

Transfer model		TX10A	
Gear ratio	High	1.000	
	Low	2.020	
Number of teeth	Main gear	29	
	Low gear	37	
	Counter gear	High	38
		Low	24
	Front drive sprocket	41	
Front drive shaft	41		
Oil capacity	ℓ (US qt, Imp qt)	2.2 (2-3/8, 2)	

Inspection and Adjustment

GEAR END PLAY

Unit: mm (in)

Front drive sprocket	0.2 - 0.35 (0.0079 - 0.0138)
Low gear	0.2 - 0.35 (0.0079 - 0.0138)
Counter gear	0 - 0.2 (0 - 0.008)

Main gear bearing

Allowable clearance	0 - 0.15 mm (0 - 0.0059 in)	
Thickness mm (in)	Part number	
2.60 (0.1024)	33114-73P00	
2.69 (0.1059)	33114-73P01	
2.78 (0.1094)	33114-73P02	

AVAILABLE SNAP RING

Mainshaft front bearing

Allowable clearance	0 - 0.15 mm (0 - 0.0059 in)	
Thickness mm (in)	Part number	
3.10 (0.1220)	33138-73P10	
3.19 (0.1256)	33138-73P11	
3.28 (0.1291)	33138-73P12	

AVAILABLE SHIM

Counter gear rear bearing

Allowable clearance	0 - 0.2 mm (0 - 0.008 in)	
Thickness mm (in)	Part number	
0.1 (0.004)	33112-C6900	
0.2 (0.008)	33112-C6901	
0.3 (0.012)	33112-C6902	
0.4 (0.016)	33112-C6903	
0.5 (0.020)	33112-33G00	
0.6 (0.024)	33112-33G01	

Mainshaft rear bearing

Allowable clearance	0 - 0.15 mm (0 - 0.0059 in)	
Thickness mm (in)	Part number	
1.80 (0.0709)	33138-73P20	
1.89 (0.0744)	33138-73P21	
1.98 (0.0780)	33138-73P22	
2.07 (0.0815)	33138-73P23	
2.16 (0.0850)	33138-73P24	