

# ACCELERATOR CONTROL, FUEL & EXHAUST SYSTEMS

GI

MA

EM

LC

EC

**FE**

GL

MT

AT

TF

PD

FA

RA

BR

ST

RS

BT

HA

EL

IDX

## SECTION **FE**

### CONTENTS

<b>PREPARATION</b> .....2	<b>FUEL SYSTEM</b> .....4
Special Service Tools .....2	Fuel Tank .....5
<b>ACCELERATOR CONTROL SYSTEM</b> .....3	Fuel Pump and Gauge .....6
Accelerator Control System.....3	<b>EXHAUST SYSTEM</b> .....7
Adjusting Accelerator Wire .....3	

# PREPARATION

## Special Service Tools

The actual shapes of Kent-Moore tools may differ from those of special service tools illustrated here.

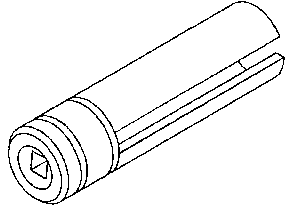
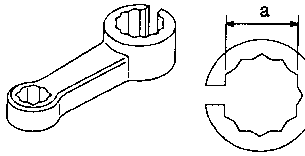
Tool number (Kent-Moore No.) Tool name	Description
KV10117100 (J3647-A) Heated oxygen sensor wrench	 <p data-bbox="1013 350 1490 407">Loosening or tightening rear heated oxygen sensor (For left bank)</p> <p data-bbox="441 569 505 590">NT379</p> <p data-bbox="1013 564 1349 590"><b>For 22 mm (0.87 in) hexagon nut</b></p>
KV10114400 (J38365) Heated oxygen sensor wrench	 <p data-bbox="1013 606 1490 663">Loosening or tightening rear heated oxygen sensor (For right bank)</p> <p data-bbox="441 764 505 785">NT636</p> <p data-bbox="1013 760 1195 785"><b>a: 22 mm (0.87 in)</b></p>

# ACCELERATOR CONTROL SYSTEM

## Accelerator Control System

### CAUTION:

- When removing accelerator wire, make a mark to indicate lock nut's initial position.
- Check that throttle valve opens fully when accelerator pedal is fully depressed. Also check that it returns to idle position when pedal is released.
- Check accelerator control parts for improper contact with any adjacent parts.
- When connecting accelerator wire, be careful not to twist or scratch its inner wire.
- Refer to EL section ("AUTOMATIC SPEED CONTROL DEVICE") for ASCD wire adjustment.

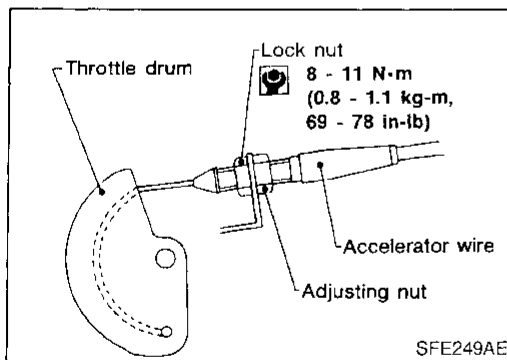
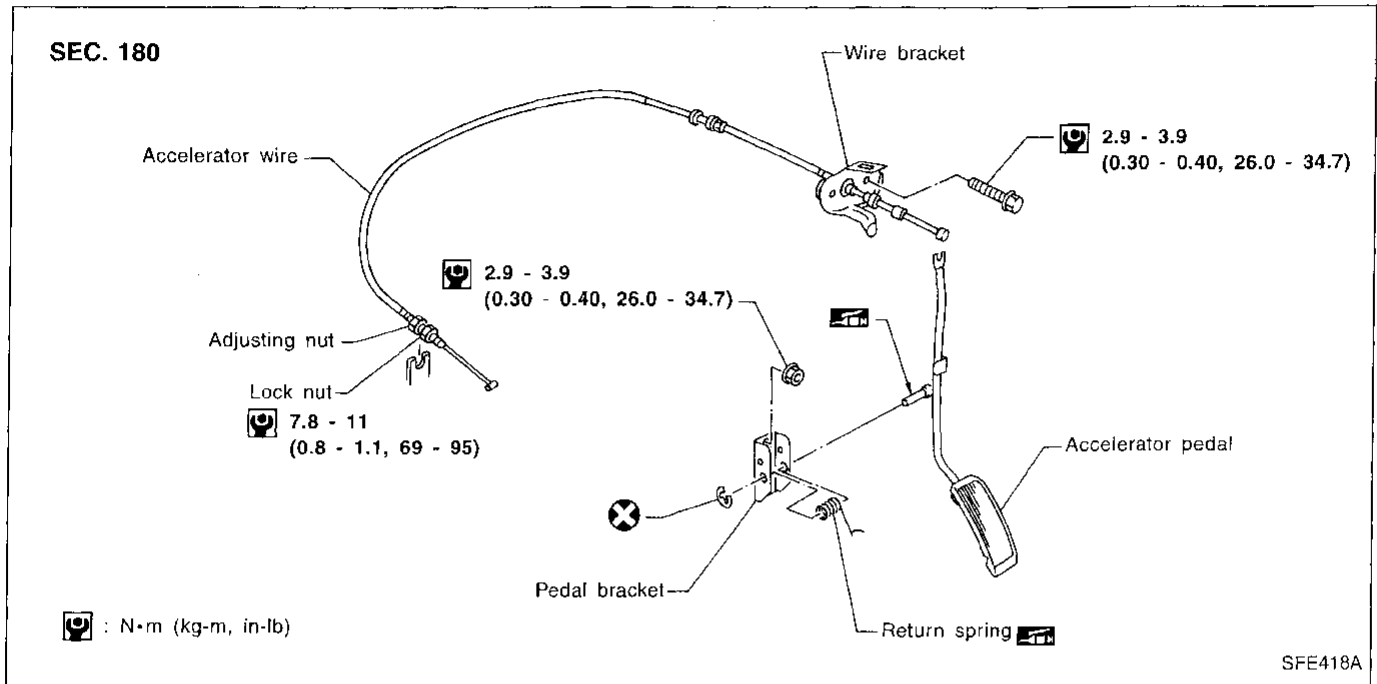

### Adjusting Accelerator Wire

1. Loosen lock nut, and tighten adjusting nut until throttle drum starts to move.
2. From that position turn back adjusting nut 1.5 to 2 turns, and secure lock nut.

CI  
MA  
EM  
LC  
EC  
FE  
CL  
MT  
AT  
TF  
PD  
FA  
RA  
BR  
ST  
RS  
BT  
HA  
EL  
DX

# FUEL SYSTEM

## WARNING:

When replacing fuel line parts, be sure to observe the following:

- Put a "CAUTION: INFLAMMABLE" sign in workshop.
- Do not smoke while servicing fuel system. Keep open flames and sparks away from work area.
- Be sure to furnish the workshop with a CO<sub>2</sub> fire extinguisher.

## CAUTION:

- Before removing fuel line parts, carry out the following procedures:
  - a. Put drained fuel in an explosion-proof container and put lid on securely.
  - b. Release fuel pressure from fuel line. Refer to MA section ("Changing Fuel Filter").
  - c. Disconnect battery ground cable.
- Always replace O-ring with new ones.
- Do not kink or twist hose and tube when they are installed.
- Do not tighten hose clamps excessively to avoid damaging hoses.
- When installing fuel check valve, be careful of its designated direction. Refer to EC section ("EVAPORATIVE EMISSION SYSTEM").
- After installation, run engine and check for fuel leaks at connections.

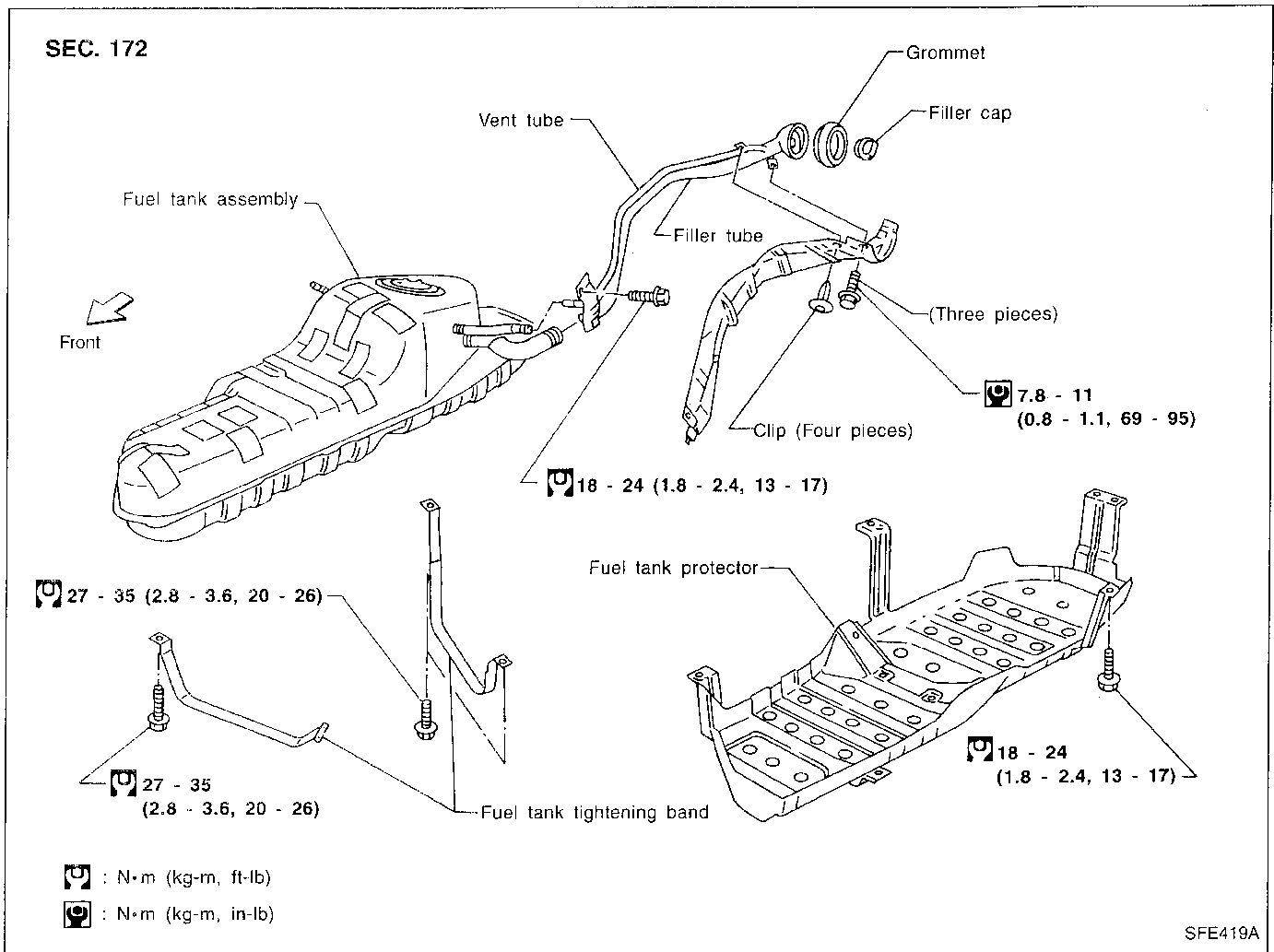

# FUEL SYSTEM

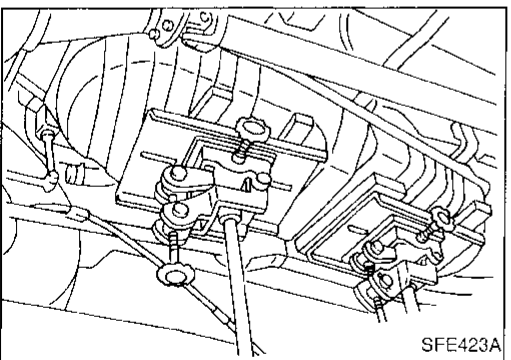
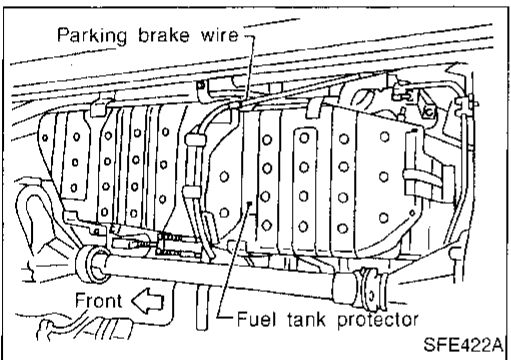
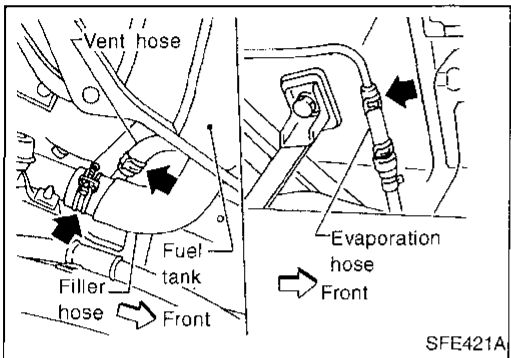
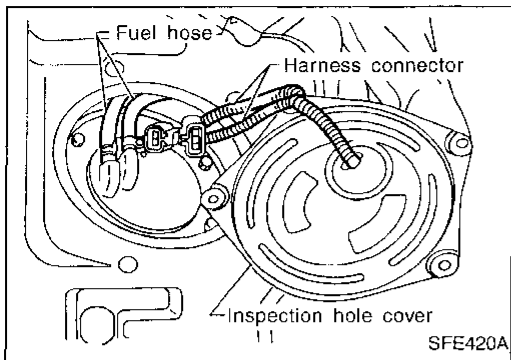

## Fuel Tank

### REMOVAL AND INSTALLATION

1. Release fuel pressure from fuel line.  
Refer to MA section ("Changing Fuel Filter").
  2. Remove inspection hole cover located behind the rear seat.
  3. Disconnect harness connectors under inspection hole cover.
  4. Disconnect fuel hoses.
    - Put mating marks on hoses for correct installation.
  5. Disconnect filler hose, vent hose and evaporation hose at fuel tank side.
  6. Remove parking brake wire from fuel tank protector.
  7. Remove fuel tank protector.
  8. Remove fuel tank band mounting bolts while supporting fuel tank.
  9. Remove fuel tank.
- Installation procedure is the reverse order of removal.

GI

MA

EM

LC

EC

**FE**

CL

MT

AT

TF

PD

FA

RA

BR

ST

RS

BT

HA

EL

IDX

## Fuel Pump and Gauge

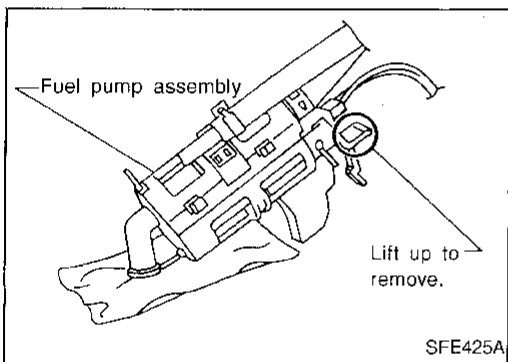
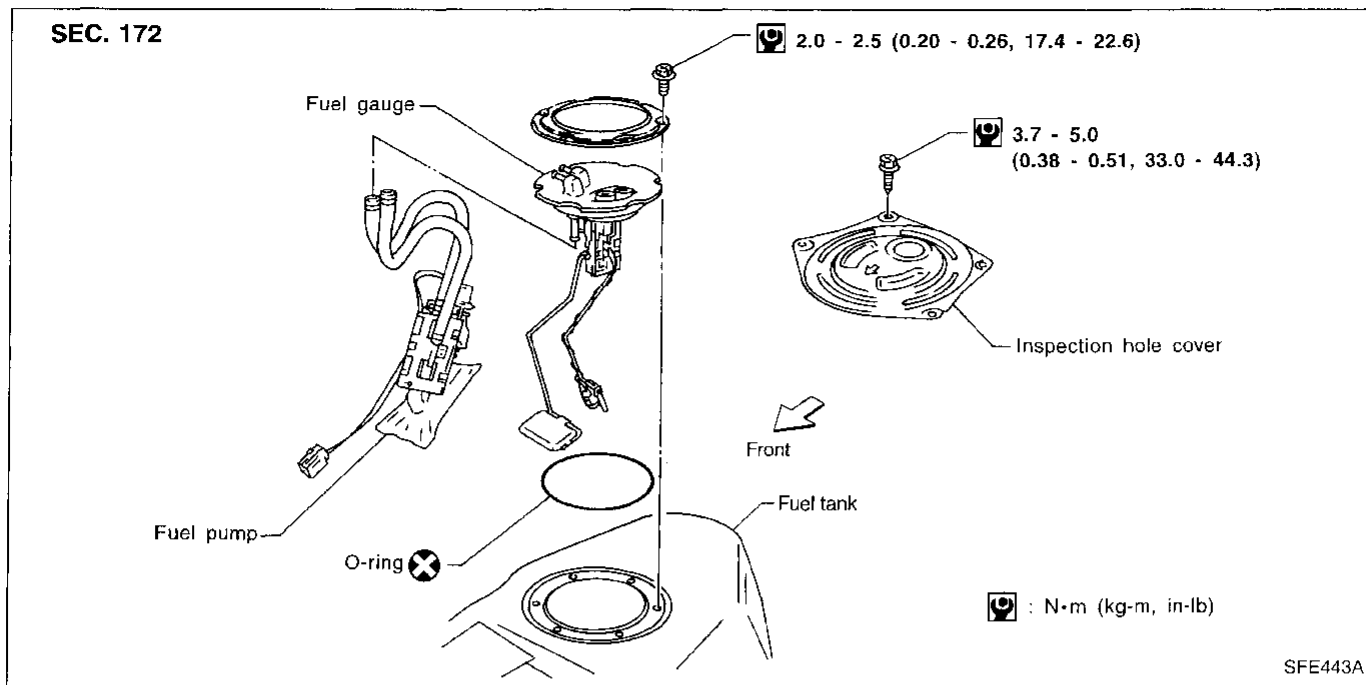

### REMOVAL AND INSTALLATION

1. Release fuel pressure from fuel line. Refer to MA section ("Changing Fuel Filter").
  2. Remove inspection hole cover located behind the rear seat.
  3. Disconnect harness connectors and fuel tubes from upper plate of fuel gauge.
    - Put mating marks on tubes for correct installation.
  4. Remove fuel gauge retainer and fuel gauge.
  5. Remove fuel pump with bracket while lifting the pawl of the fuel pump bracket upward.
6. Installation procedure is the reverse order of removal.
    - Install fuel gauge as shown.

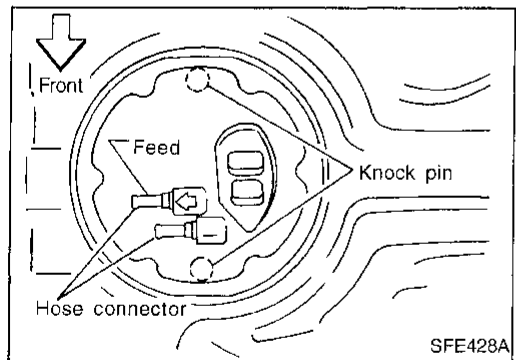

# EXHAUST SYSTEM

## CAUTION:

- Always replace exhaust gaskets with new ones when reassembling.
- With engine running, check all tube connections for exhaust gas leaks, and entire system for unusual noises.
- Check to ensure that mounting brackets and mounting insulators are installed properly and free from undue stress. Improper installation could result in excessive noise or vibration.
- Discard any heated oxygen sensor which has been dropped from a height of more than 0.5 m (19.7 in) onto a hard surface such as a concrete floor; use a new one.
- Do not overtorque the oxygen sensor. Doing so may cause damage to the oxygen sensor, resulting in the MIL coming on.

2WD model  
SEC. 200

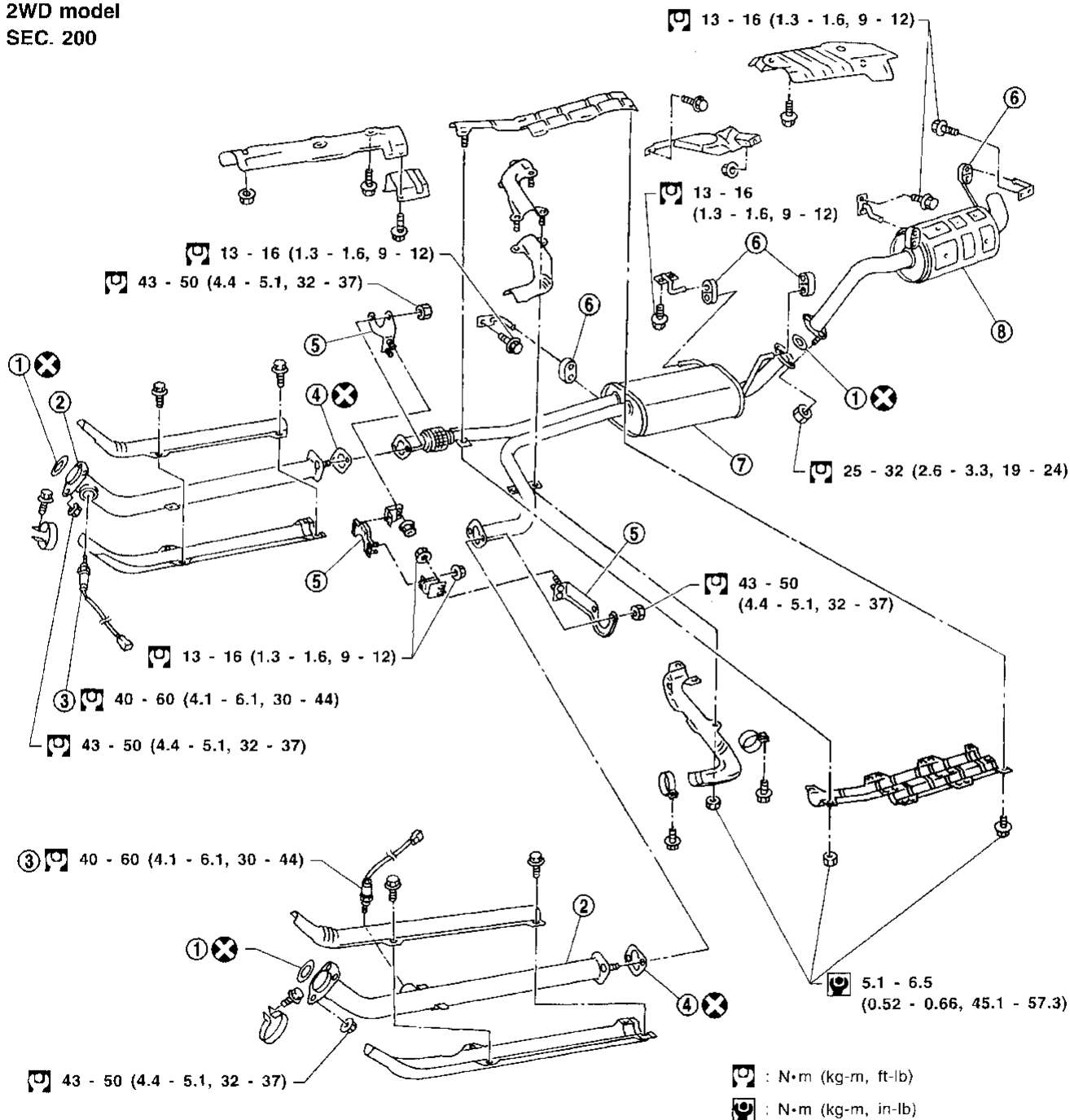

- ① Gasket
- ② Front tube
- ③ Rear heated oxygen sensor

- ④ Gasket
- ⑤ Mounting bracket

- ⑥ Mounting rubber
- ⑦ Center muffler
- ⑧ Rear muffler

# EXHAUST SYSTEM

4WD model  
SEC. 200

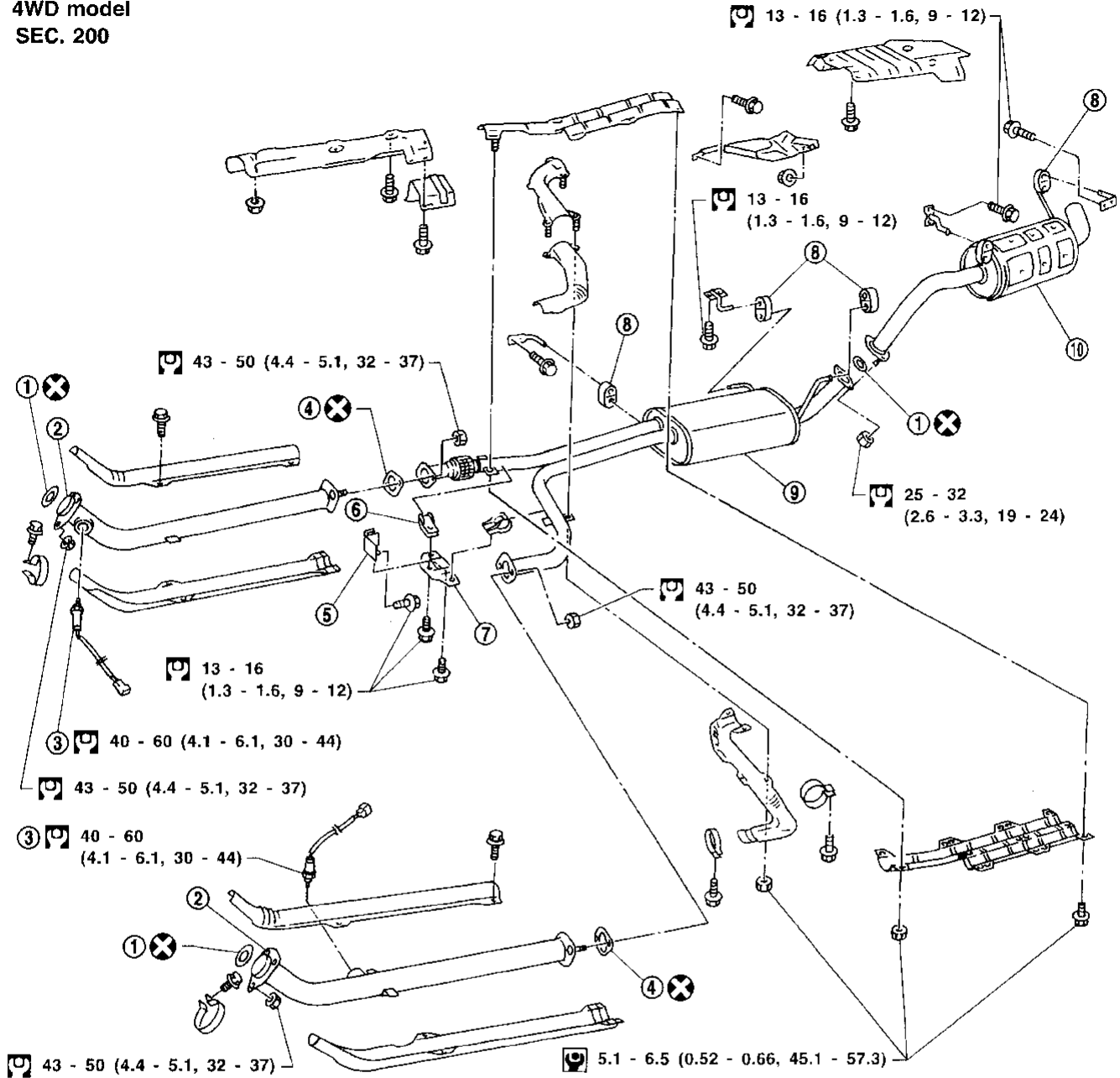

: N·m (kg-m, ft-lb)

: N·m (kg-m, in-lb)

SFE442A

- ① Gasket
- ② Front tube
- ③ Rear heated oxygen sensor
- ④ Gasket

- ⑤ Mounting rubber
- ⑥ Clamp
- ⑦ Mounting bracket

- ⑧ Mounting rubber
- ⑨ Center muffler
- ⑩ Rear muffler