

MANUAL TRANSMISSION

SECTION MT

CONTENTS

GI
MA
EM
LC
EF &
EC
FE
CL
MT
AT
TF
PD
FA
RA
BR
ST
BF
HA
EL

<input type="checkbox"/>	FS5W71C	<input type="checkbox"/>
PREPARATION		2
Special Service Tools.....		2
Commercial Service Tools.....		3

<input type="checkbox"/>	FS5R30A	<input type="checkbox"/>
PREPARATION		4
Special Service Tools.....		4
Commercial Service Tool.....		5

<input type="checkbox"/>	FS5W71C & FS5R30A	<input type="checkbox"/>
ON-VEHICLE SERVICE		6
Checking M/T Oil.....		6
Replacing Rear Oil seal — 2WD Model.....		6
REMOVAL AND INSTALLATION		7
Removal — 2WD Model.....		7
Removal — 4WD Model.....		7
Installation.....		8

<input type="checkbox"/>	FS5W71C	<input type="checkbox"/>
MAJOR OVERHAUL		10
Case Components.....		10
Gear Components — 2WD model.....		11
Gear Components — 4WD model.....		12
Shift Control Components — 2WD model.....		13
Shift Control Components — 4WD model.....		14
DISASSEMBLY		15
Case Components.....		15
Shift Control Components.....		15
Gear Components.....		17
INSPECTION		19
Shift Control Components.....		19
Gear Components.....		19

ASSEMBLY	21
Gear Components.....	21
Shift Control Components.....	28
Case Components.....	29

<input type="checkbox"/>	FS5R30A	<input type="checkbox"/>
MAJOR OVERHAUL		33
Case Components.....		33
Gear Components.....		34
Shift Control Components.....		36



DISASSEMBLY	37
Case Components.....	37
Shift Control Components.....	38
Gear Components.....	39
INSPECTION	43
Shift Control Components.....	43
Gear Components.....	43
ASSEMBLY	45
Gear Components.....	45
Shift Control Components.....	53
Case Components.....	54

<input type="checkbox"/>	FS5W71C & FS5R30A	<input type="checkbox"/>
SERVICE DATA AND SPECIFICATIONS (SDS)		56
General Specifications.....		56

<input type="checkbox"/>	FS5W71C	<input type="checkbox"/>
Inspection and Adjustment.....		57

<input type="checkbox"/>	FS5R30A	<input type="checkbox"/>
Inspection and Adjustment.....		59

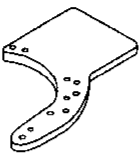
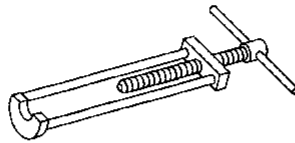
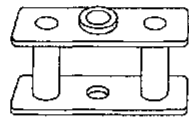
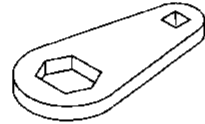
Special Service Tools

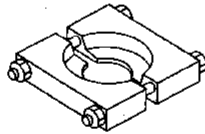
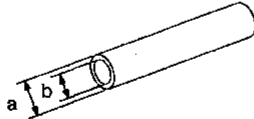
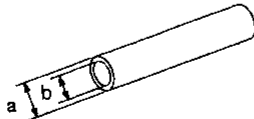
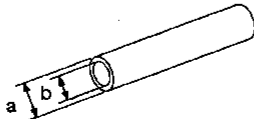
Tool number (Kent-Moore No.) Tool name	Description
ST23810001 (—) Adapter setting plate	 <p>Fixing adapter plate with gear assembly</p> <p>NT066</p>
KV32101330 (See J26349-A) Puller	 <p>Removing overdrive mainshaft bearing</p> <p>NT067</p>
KV31100401 (—) Transmission press stand	 <p>Pressing counter gear and mainshaft</p> <p>NT068</p>
ST22520000 (J26348) Wrench	 <p>Tightening mainshaft lock nut</p> <p>NT069</p>
ST23540000 (J25689-A) Pin punch	 <p>Removing and installing fork rod retaining pin</p> <p>NT070</p>
ST30031000 (J22912-01) Puller	 <p>Removing and installing 1st gear bushing Removing main drive gear bearing</p> <p>NT071</p>
ST23860000 (—) Drift	 <p>Installing counter drive gear</p> <p>a: 38 mm (1.50 in) dia. b: 33 mm (1.30 in) dia.</p> <p>NT065</p>
ST22360002 (J25679-01) Drift	 <p>Installing counter gear front and rear end bearings</p> <p>a: 29 mm (1.14 in) dia. b: 23 mm (0.91 in) dia.</p> <p>NT065</p>
ST22350000 (J25678-01) Drift	 <p>Installing OD gear bushing</p> <p>a: 34 mm (1.34 in) dia. b: 28 mm (1.10 in) dia.</p> <p>NT065</p>

Special Service Tools (Cont'd)

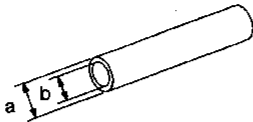
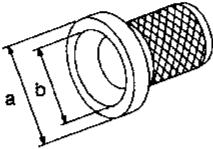
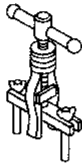
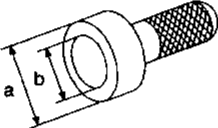
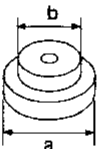
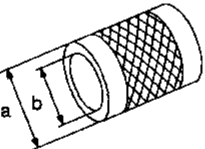
Tool number (Kent-Moore No.) Tool name	Description	
ST23800000 (J25691-01) Drift	 <p>NT065</p>	Installing front cover oil seal a: 44 mm (1.73 in) dia. b: 31 mm (1.22 in) dia.
ST33400001 (J26082) Drift	 <p>NT086</p>	Installing rear oil seal a: 60 mm (2.36 in) dia. b: 47 mm (1.85 in) dia.
ST33290001 (J25810-A) Puller	 <p>NT076</p>	Removing rear oil seal
ST30720000 (—) Drift	 <p>NT115</p>	Installing mainshaft ball bearing a: 77 mm (3.03 in) dia. b: 55.5 mm (2.185 in) dia.
ST30613000 (J25742-3) Drift	 <p>NT073</p>	Installing main drive gear bearing a: 71.5 mm (2.815 in) dia. b: 47.5 mm (1.870 in) dia.
ST33200000 (J26082) Drift	 <p>NT091</p>	Installing counter rear bearing a: 60 mm (2.36 in) dia. b: 44.5 mm (1.752 in) dia.

Commercial Service Tools

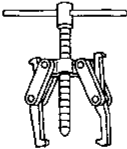
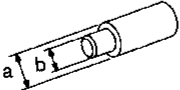
Tool name	Description	
Puller	 <p>NT077</p>	Removing counter bearings, counter drive and OD gears
Drift	 <p>NT074</p>	Installing countershaft rear end bearing (FS5W71C-4WD model) a: 40 mm (1.57 in) dia. b: 30 mm (1.18 in) dia.

Special Service Tools

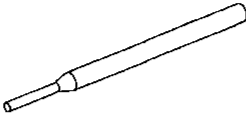
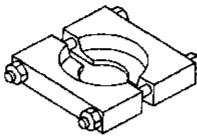
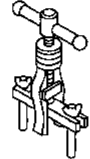
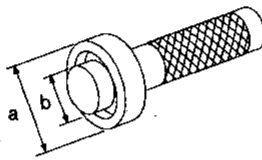
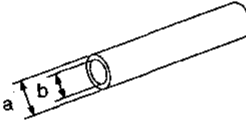
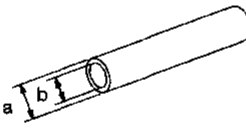
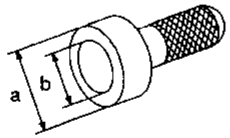
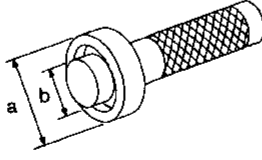
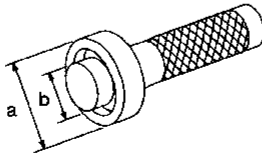
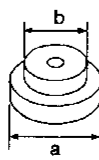
Tool number (Kent-Moore No.) Tool name	Description
ST23540000 (J25689-A) Pin punch	 <p>NT070</p> <p>Removing and installing retaining pin</p>
ST30031000 (J22912-01) Puller	 <p>NT071</p> <p>Removing 1st & 2nd synchronizer assembly Removing counter gear rear thrust bearing Removing main drive bearing</p>
ST33290001 (J25810-A) Puller	 <p>NT076</p> <p>Removing rear oil seal</p>
ST33230000 (—) Drift	 <p>NT084</p> <p>Removing mainshaft and counter gear</p> <p>a: 51 mm (2.01 in) dia. b: 28.5 mm (1.122 in) dia.</p>
ST22350000 (J25678-01) Drift	 <p>NT065</p> <p>Removing counter gear front bearing (Use with KV38100300)</p> <p>a: 34 mm (1.34 in) dia. b: 28 mm (1.10 in) dia.</p>
KV38100300 (J25523) Drift	 <p>NT065</p> <p>Removing counter gear front bearing (Use with ST22350000) Installing counter gear rear bearing</p> <p>a: 54 mm (2.13 in) dia. b: 32 mm (1.26 in) dia.</p>
ST30720000 ① (J34286) ② (J34331) Drift	 <p>NT115</p> <p>① Removing mainshaft front bearing ② Installing mainshaft front bearing</p> <p>a: 77 mm (3.03 in) dia. b: 55.5 mm (2.185 in) dia.</p>
ST33220000 (J25804-01) Drift	 <p>NT084</p> <p>Removing and installing counter gear rear end bearing (4WD model)</p> <p>a: 37 mm (1.46 in) dia. b: 22 mm (0.87 in) dia.</p>
ST33210000 ① (J25523) ② (J25803-01) Drift	 <p>NT084</p> <p>① Installing counter gear front bearing ② Installing front cover oil seal</p> <p>a: 44 mm (1.73 in) dia. b: 24.5 mm (0.965 in) dia.</p>
ST30613000 (J25742-3) Drift	 <p>NT073</p> <p>Installing main drive gear bearing</p> <p>a: 72 mm (2.83 in) dia. b: 48 mm (1.89 in) dia.</p>

Special Service Tools (Cont'd)

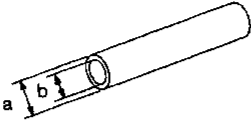
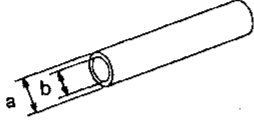
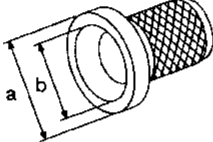
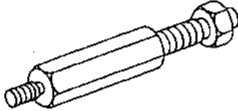
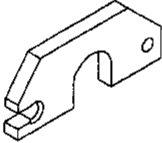
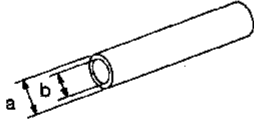
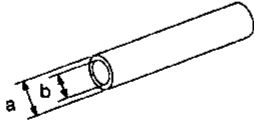
Tool number (Kent-Moore No.) Tool name	Description
ST37750000 ① (J34286) ② (J34332) ③ (J34334) ④ (J25679-01) Drift NT065	 <p>① Removing counter gear rear bearing ② Installing OD gear bushing ② Installing reverse cone ③ Installing reverse counter gear ④ Installing counter gear rear end bearing</p> <p>a: 40 mm (1.57 in) dia. b: 31 mm (1.22 in) dia.</p>
ST22452000 (J34337) Drift NT065	 <p>Installing reverse hub Installing mainshaft rear bearing (2WD model)</p> <p>a: 45 mm (1.77 in) dia. b: 36 mm (1.42 in) dia.</p>
ST33400001 (J26082) Drift NT086	 <p>Installing rear oil seal</p> <p>a: 60 mm (2.36 in) dia. b: 47 mm (1.85 in) dia.</p>
(J26349-3) Puller leg NT078	 <p>Installing mainshaft and counter gear (Use with J34328)</p>
(J34328) Puller NT079	 <p>Installing mainshaft and counter gear (Use with J26349-3)</p>
(J26092) Drift NT065	 <p>Installing sub-gear snap ring</p> <p>a: 44.5 mm (1.752 in) dia. b: 38.5 mm (1.516 in) dia.</p>
(J34342) Drift NT065	 <p>Installing OD main gear Installing reverse gear bushing</p> <p>a: 44.5 mm (1.752 in) dia. b: 40.5 mm (1.594 in) dia.</p>

Commercial Service Tool

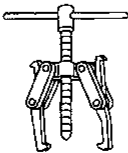
Tool name	Description
Puller NT077	 <p>Removing counter gear rear end bearing Removing mainshaft rear bearing (2WD model) Removing reverse synchronizer hub Removing reverse counter gear</p>

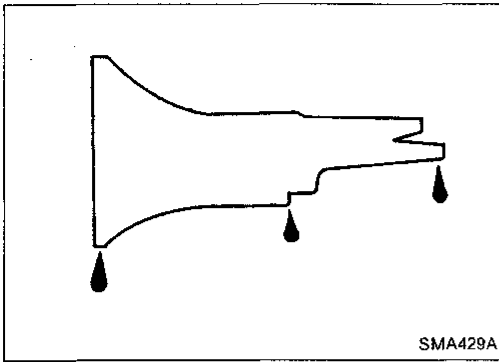

Checking M/T Oil

- Check manual transmission for oil leakage.

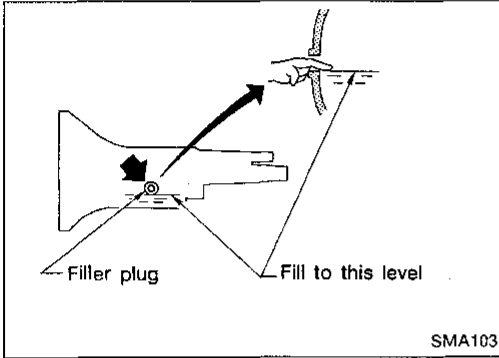

- Check oil level.

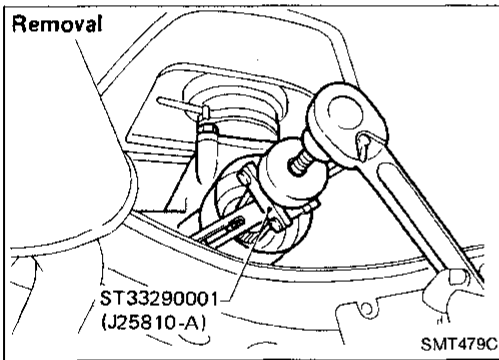

Replacing Rear Oil seal — 2WD Model

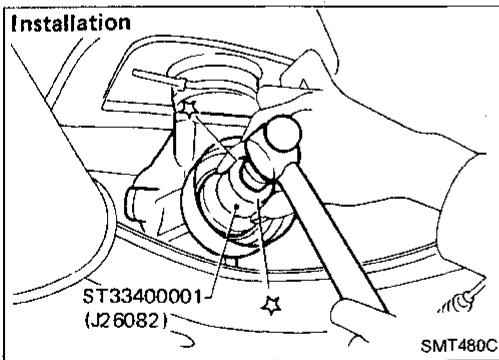

Removal — 2WD Model

- Remove propeller shaft. — Refer to section PD.
- Insert plug into rear oil seal after removing propeller shaft.

CAUTION:

Be careful not to damage spline, sleeve yoke and rear oil seal, when removing propeller shaft.

- Remove exhaust front tube A. (VG30E engine model) — Refer to section FE.

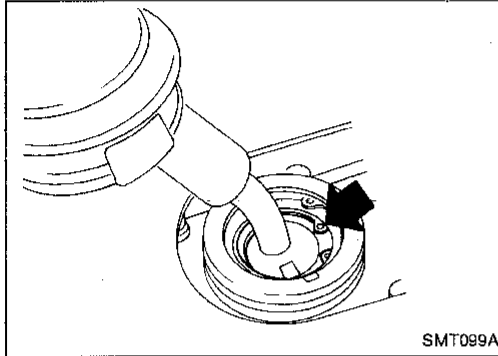

SMT099A

- Remove shift lever.
- Support engine by placing a jack under oil pan.

CAUTION:

Do not place jack under the oil pan drain plug.

- Remove transmission from engine.

WARNING:

Support Manual Transmission, while removing it.

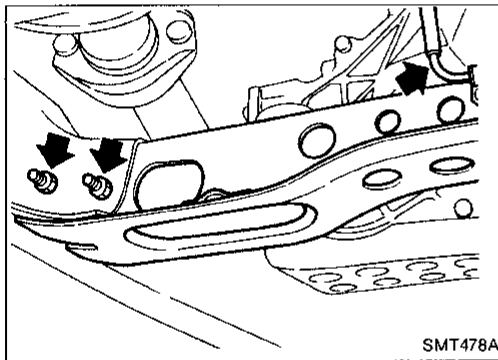

SMT478A

Removal — 4WD Model

- Remove front and rear propeller shafts. — Refer to section PD.
- Insert plug into rear oil seal of transfer after removing propeller shaft.

CAUTION:

Be careful not to damage spline, sleeve yoke and rear oil seal of transfer, when removing propeller shaft.

- Remove exhaust front tube A. (VG30E engine model) — Refer to section FE.
- Remove torsion bar springs. — Refer to REMOVAL of Torsion Bar Spring in section FA. Then remove second cross-member.

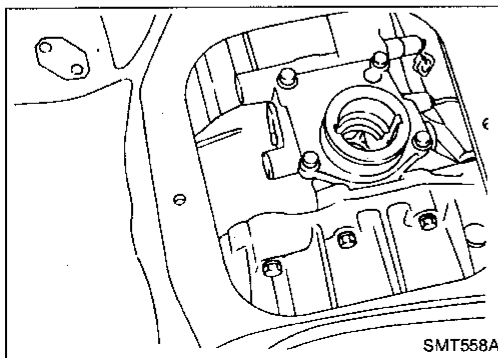

SMT558A

- Remove shift lever of transmission and transfer.
- Support engine by placing a jack under oil pan.

CAUTION:

Do not place jack under the oil pan drain plug.

- Remove transmission with transfer from engine.

WARNING:

Support Manual Transmission with transfer, while removing it.

GI

MA

EM

LC

EF & EC

FE

CL

MT

AT

TF

PD

FA

RA

BR

ST

BF

HA

EL

IDX

Installation

- Apply sealant as below: — 4WD model

KA24E engine model

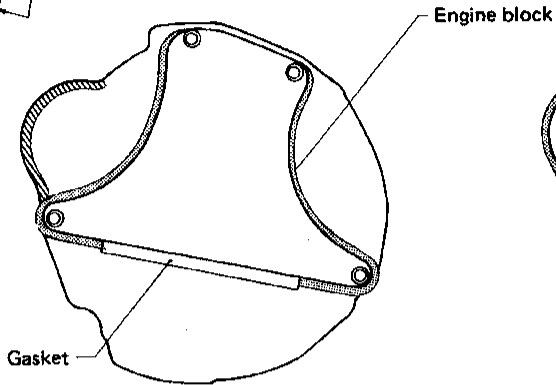
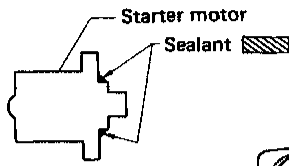

Mating surface of engine block and engine rear plate

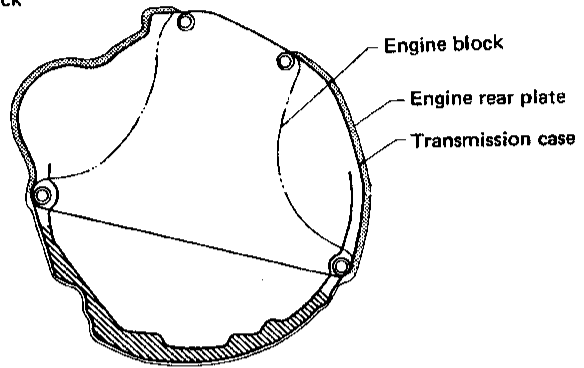

Mating surface of engine rear plate and transmission case

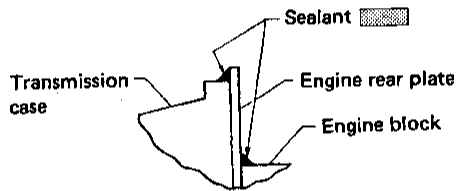

▨ : Apply recommended sealant (Nissan genuine part: KP510-00150) or equivalent.

▩ : Apply recommended sealant (Nissan genuine part: KP610-00250) or equivalent.

SMT481A

Installation (Cont'd)

VG30E engine model

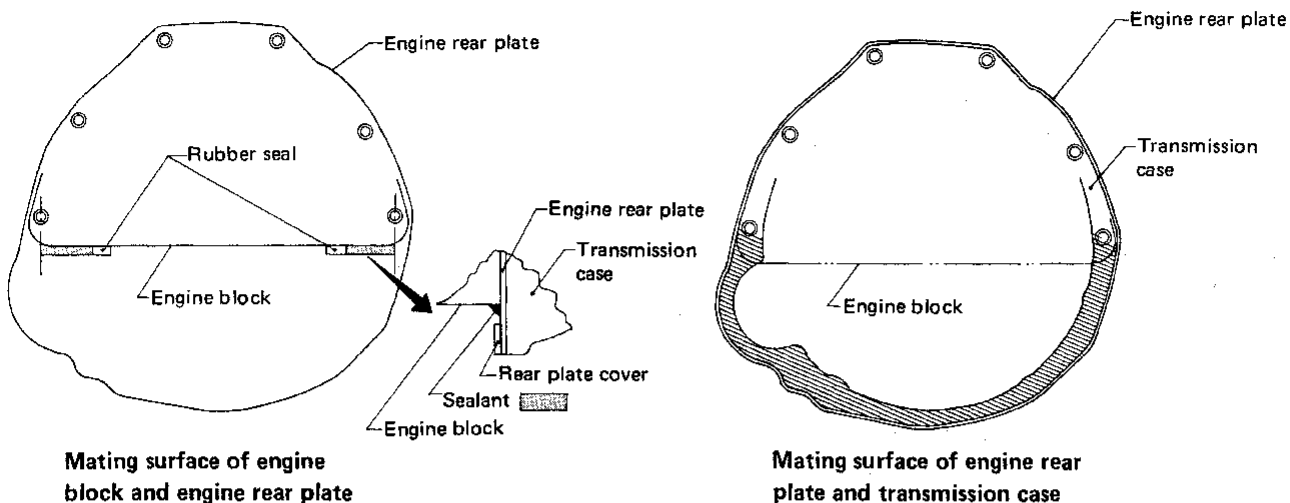

- : Apply recommended sealant (Nissan genuine part: KP510-00150) or equivalent.
- : Apply recommended sealant (Nissan genuine part: KP610-00250) or equivalent.

SMT499C

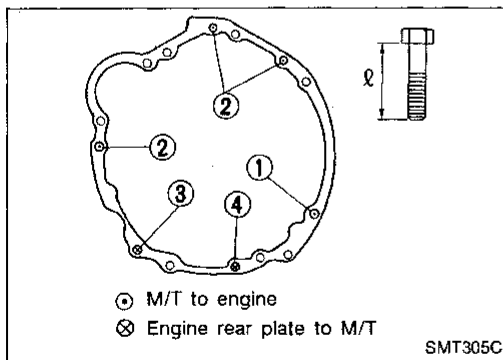

- Tighten bolt securing transmission.
- **KA24E engine model**

Bolt No.	Tightening torque N-m (kg-m, ft-lb)	ℓ mm (in)
①	39 - 49 (4.0 - 5.0, 29 - 36)	65 (2.56)
②	39 - 49 (4.0 - 5.0, 29 - 36)	60 (2.36)
③*	16 - 22 (1.6 - 2.2, 12 - 16)	25 (0.98)
④	16 - 22 (1.6 - 2.2, 12 - 16)	20 (0.79)

*: With nut

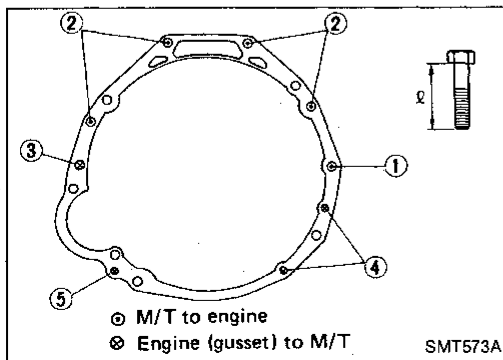

- **VG30E engine model**

Bolt No.	Tightening torque N-m (kg-m, ft-lb)	ℓ mm (in)
①	39 - 49 (4.0 - 5.0, 29 - 36)	65 (2.56)
②	39 - 49 (4.0 - 5.0, 29 - 36)	60 (2.36)
③	29 - 39 (3.0 - 4.0, 22 - 29)	55 (2.17)
④	29 - 39 (3.0 - 4.0, 22 - 29)	25 (0.98)
⑤	29 - 39 (3.0 - 4.0, 22 - 29)	25 (0.98)

Gear Components — 2WD model

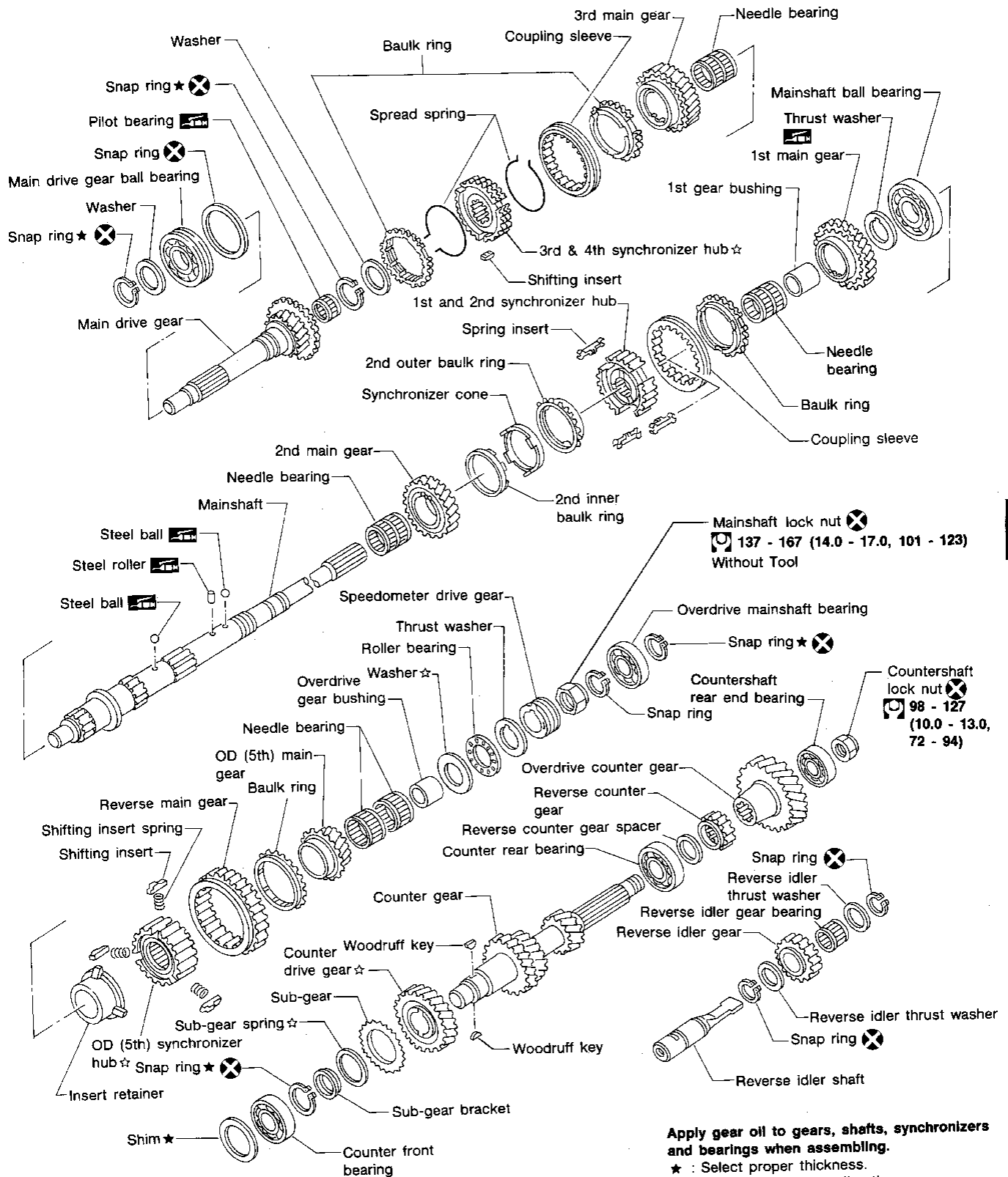

GI
MA
EM
LC
EF & EC
FE
CL
MT
AT
TF
PD
FA
RA
BR
ST
BF
HA
EL

Gear Components — 4WD model

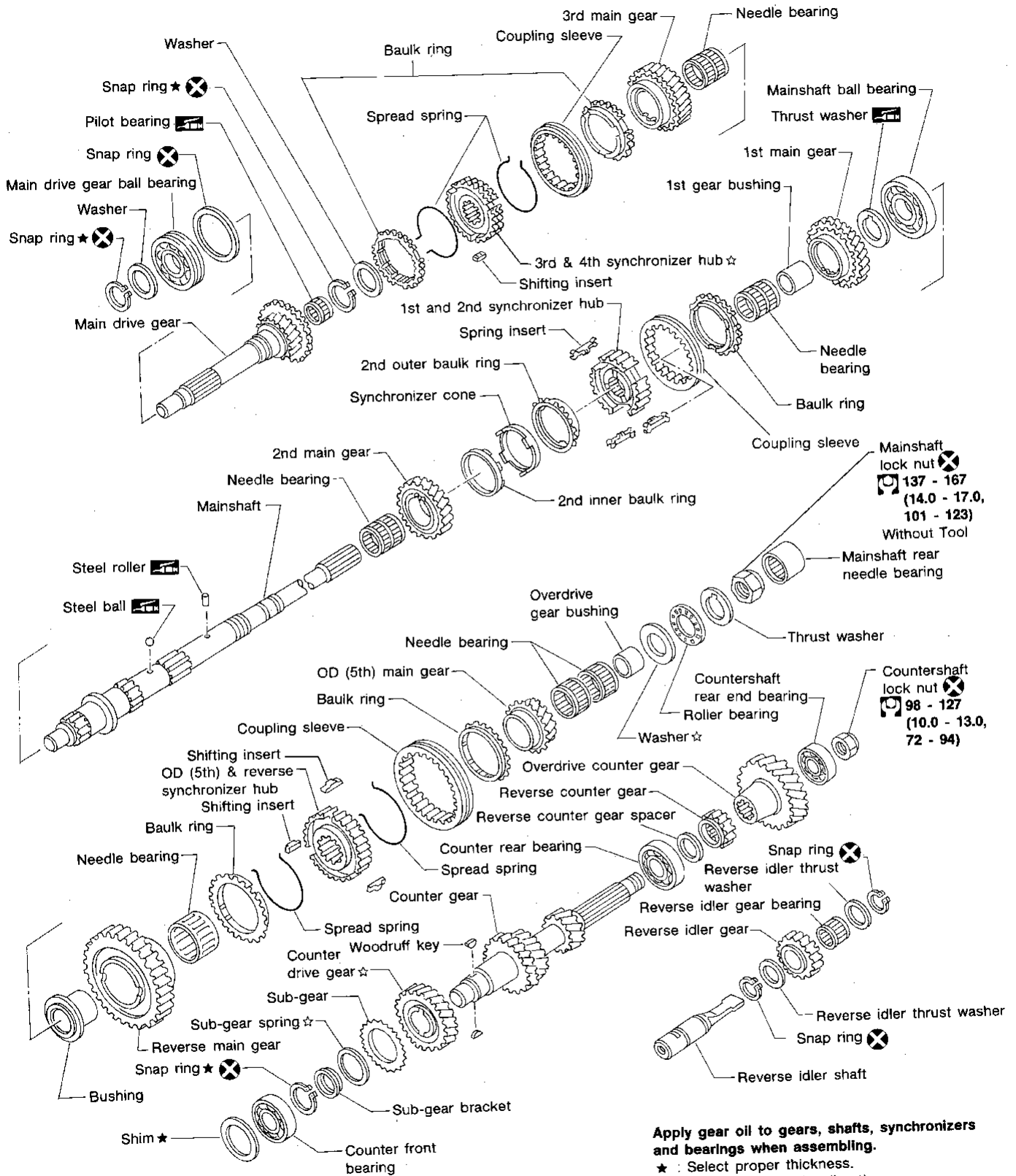

Apply gear oil to gears, shafts, synchronizers and bearings when assembling.
 ★ : Select proper thickness.
 ☆ : Pay attention to its direction.
 [Symbol] : N·m (kg·m, ft·lb)

Shift Control Components — 2WD model

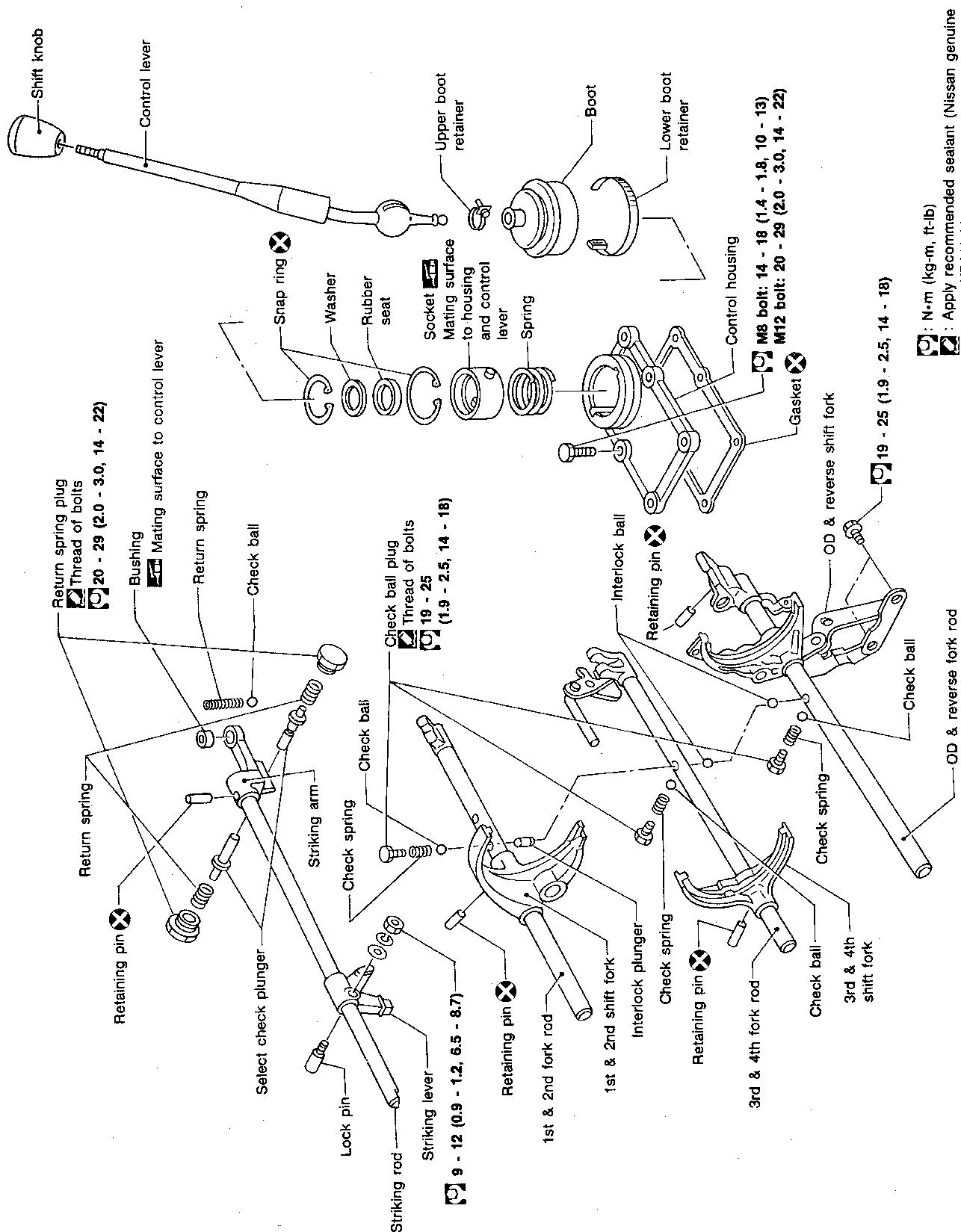

⊗ : N·m (kg·m, ft·lb)
 ⊠ : Apply recommended sealant (Nissan genuine part: KP610-00250) or equivalent.

GI
 VA
 EM
 LC
 EF & EC
 FE
 CL
 MT
 AT
 TF
 PD
 FA
 RA
 BR
 ST
 BF
 HA
 EL

Shift Control Components — 4WD model

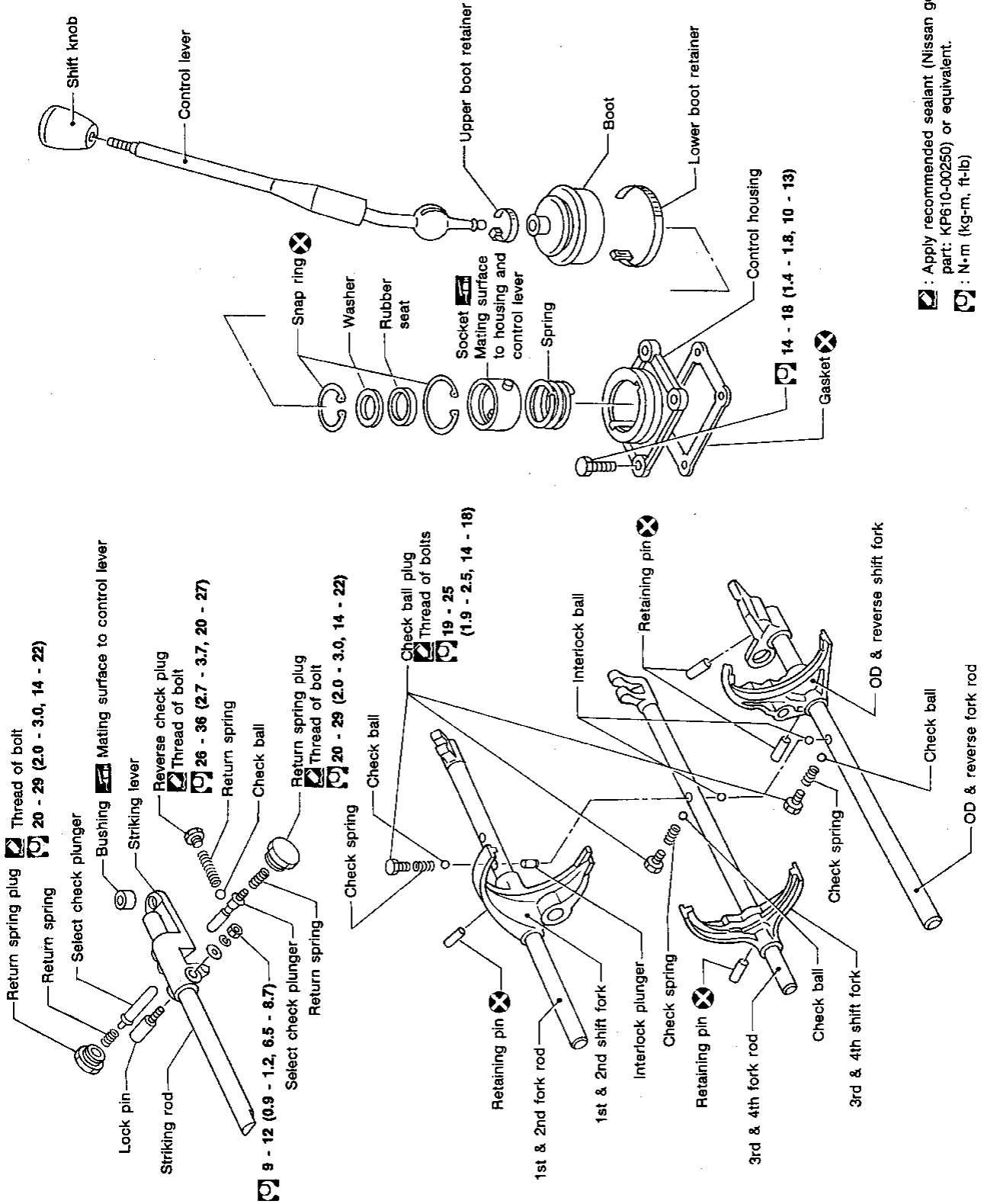

: Apply recommended sealant (Nissan genuine part: KP610-00250) or equivalent.
 : N·m (kg-m, ft-lb)

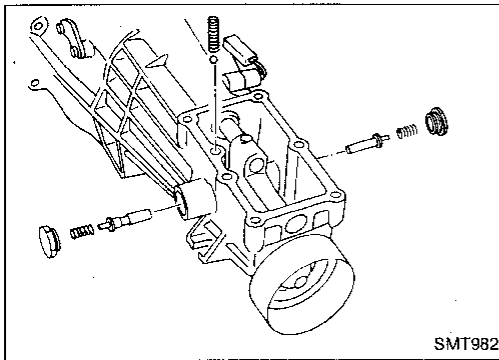

Case Components

1. Remove rear extension.
 - a. Remove control housing, check ball, return spring plug, select check plunger and return springs.

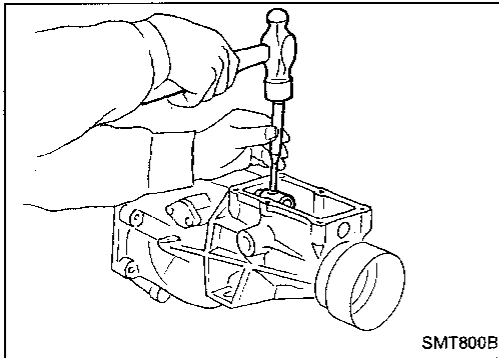

- b. Drive out striking arm retaining pin.
 - c. Remove striking arm from striking rod.
 - d. Remove rear extension by lightly tapping it.

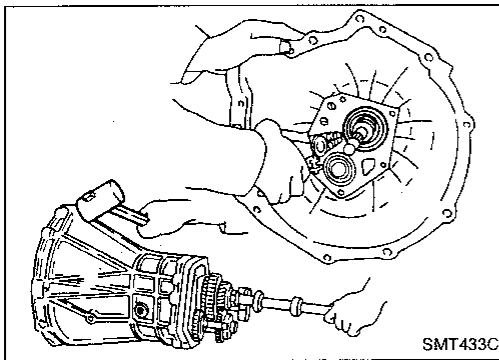

2. Remove front cover, gasket, shim of countershaft front bearing, and snap ring of main drive gear ball bearing.
3. Separate transmission case from adapter plate.

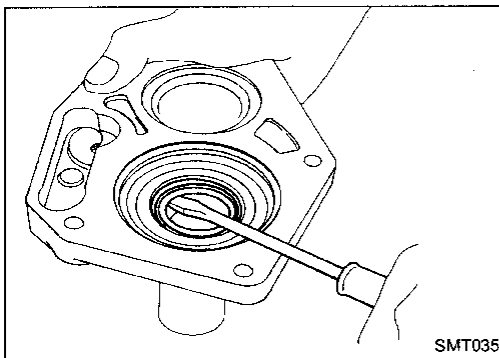

4. Remove oil seal of front cover.
Be careful not to damage mating surface of front cover.

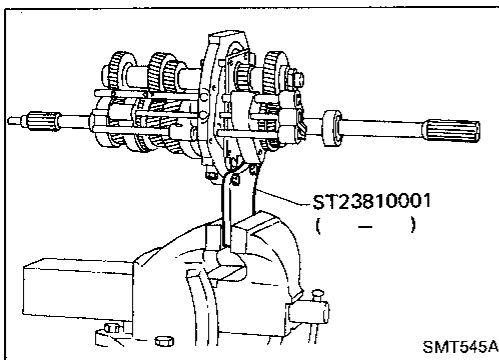

Shift Control Components

1. Set up Tool on adapter plate.
2. Remove striking rod from adapter plate.
3. Remove check ball plugs, check springs, and check balls.

GI

MA

EM

LC

EF &
EC

FE

CL

MT

AT

TF

PD

FA

RA

BR

ST

BF

HA

EL

IDX

Shift Control Components (Cont'd)

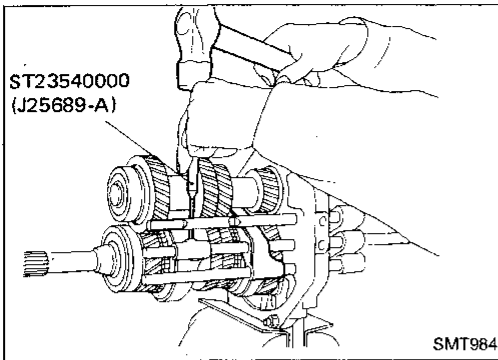

4. Drive out retaining pins. Then drive out fork rods and remove interlock balls.

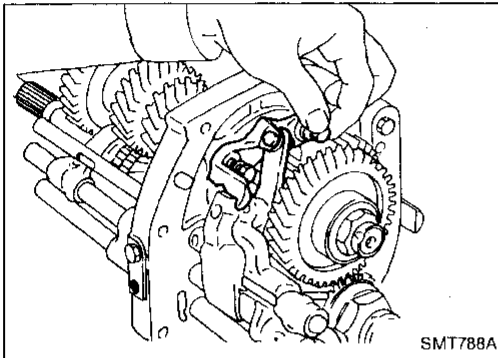

5. Remove lever bracket securing bolt (2WD model).

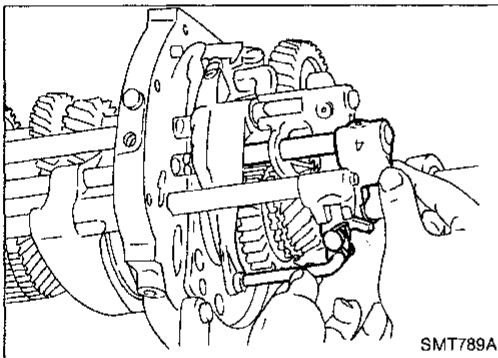

6. Draw out 3rd-4th fork rod (2WD model).

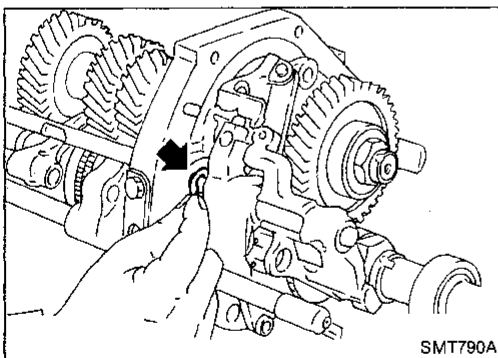

7. Remove E-ring from OD-rev. fork rod (2WD model).

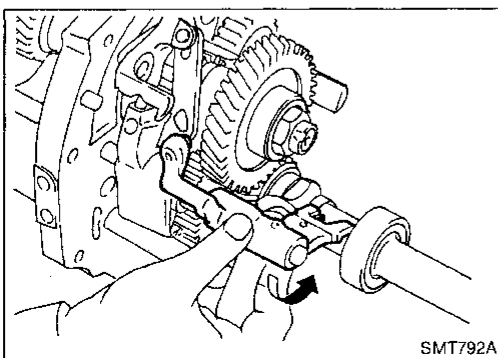

8. Draw out OD-rev. fork shaft by rotating OD-rev. bracket counterclockwise (2WD model).

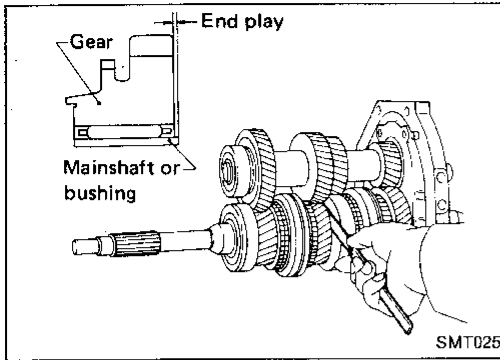

Gear Components

1. Before disassembly, measure each gear end play.
- If end play is not within the specified limit, disassemble and check the parts.
- Replace any part which is worn or damaged.

Gear end play:
Refer to SDS, MT-57.

GI

MA

EM

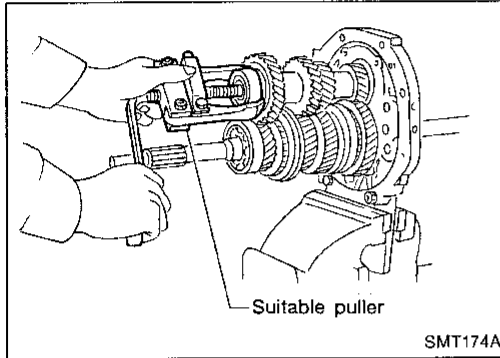

2. Mesh 2nd and reverse gear, then draw out counter front bearing with suitable puller.

LC

3. Remove snap ring and then remove sub-gear bracket, sub-gear spring and sub-gear.

EF &
EC

FE

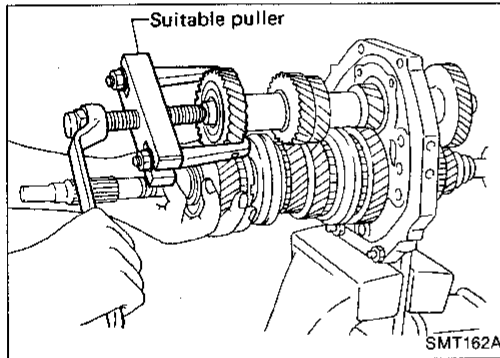

4. Draw out counter drive gear with main drive gear assembly with suitable puller.

CL

- When drawing out main drive gear assembly, be careful not to drop pilot bearing and baulk ring.

MT

5. Remove snap ring and draw out 3rd & 4th synchronizer and 3rd gear.

AT

TF

PD

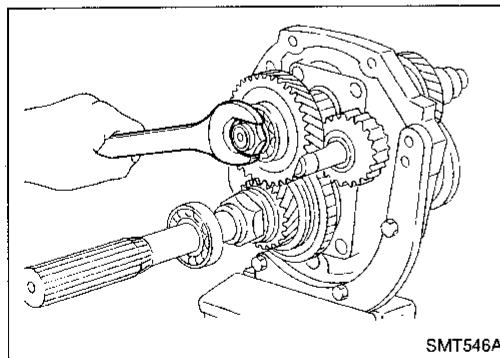

6. Disassemble parts at rear of adapter plate as follows:
 - a. Release staking on countershaft nut and mainshaft nut and loosen these nuts.

FA

Mainshaft nut: Left-hand thread

RA

BR

ST

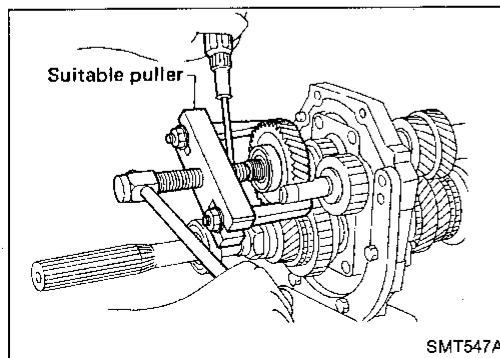

- b. Pull out OD counter gear with bearing with suitable puller.
- c. Draw out reverse counter gear and spacer.

BF

- d. Remove snap rings from reverse idler shaft, and draw out reverse idler gear, thrust washers and reverse idler gear bearing.

HA

EL

IDX

Gear Components (Cont'd)

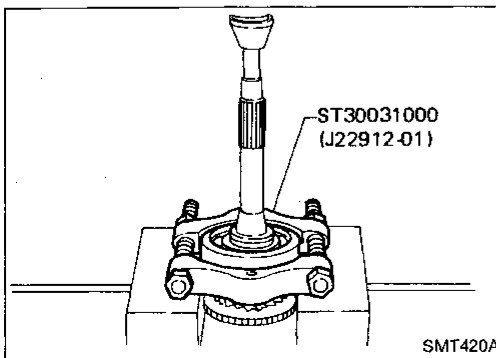
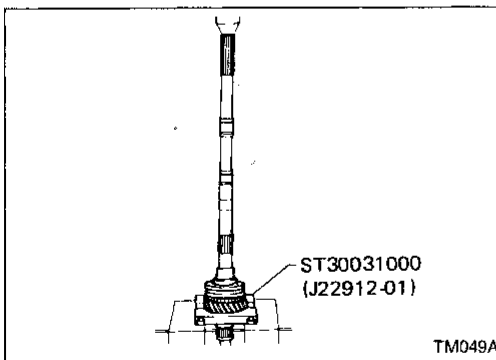
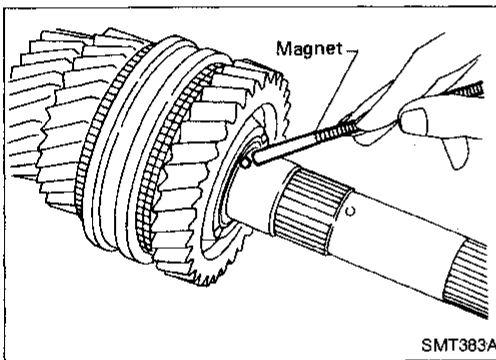
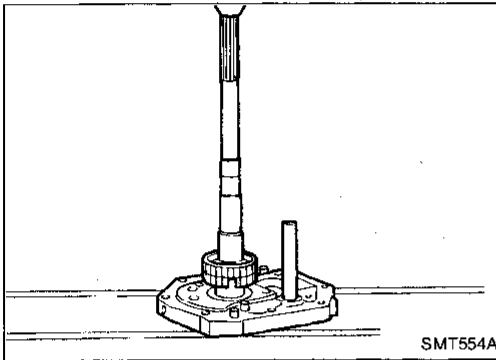
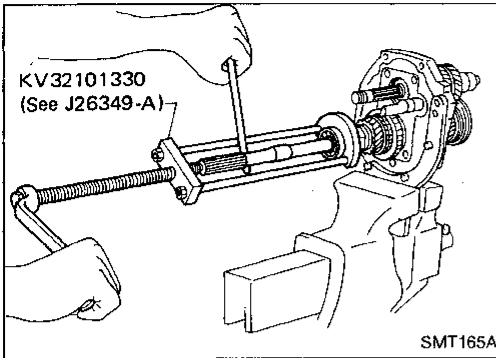

- e. Remove snap ring and pull out overdrive mainshaft bearing, then remove snap ring. (2WD model)
- f. Remove mainshaft nut.
- g. Remove speedometer drive gear and steel ball. (2WD model)
- h. Remove thrust washer, steel roller, roller bearing and washer.
- i. Remove OD main gear, needle bearing and baulk ring (OD).
- j. Remove reverse main gear (2WD), OD & reverse coupling sleeve (4WD), shifting inserts and shifting insert springs.
- k. Remove counter gear by tapping rear end of counter gear.
- l. Press out OD gear bushing, insert retainer and OD synchronizer hub.

7. Remove thrust washer, steel ball, 1st main gear and needle bearing.

Be careful not to lose steel ball.

8. Press out 1st gear mainshaft bushing together with 2nd main gear with Tool.
Then remove 2nd gear needle bearing.

9. Remove main drive gear bearing.
 - a. Remove snap ring and washer.
 - b. Remove main drive gear bearing.

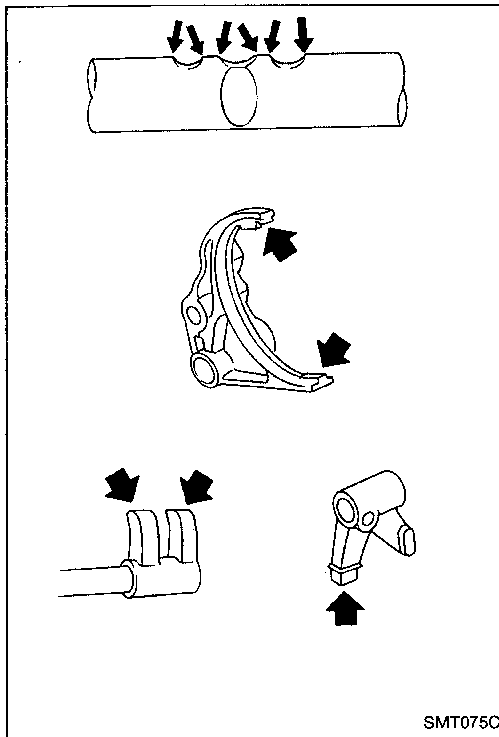

Shift Control Components

- Check contact surface and sliding surface of fork rods for wear, scratches, projections or other damage.

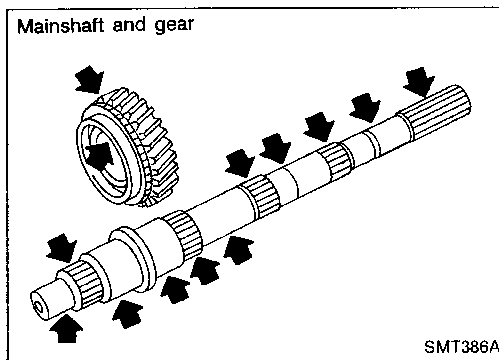

Gear Components

GEARS AND SHAFTS

- Check shafts for cracks, wear or bending.
- Check gears for excessive wear, chips or cracks.

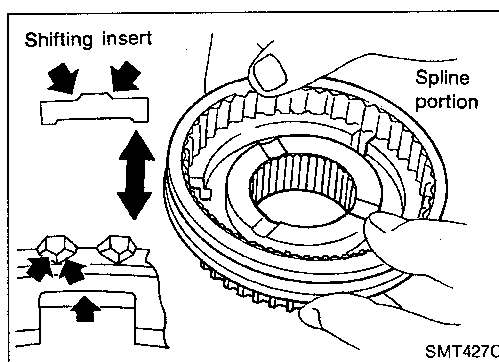
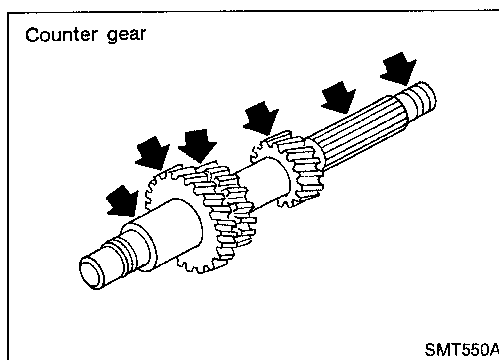

SYNCHRONIZERS

- Check spline portion of coupling sleeves, hubs and gears for wear or cracks.
- Check baulk rings for cracks or deformation.
- Check shifting inserts for wear or deformation.
- Check insert springs for deformation.

GI

MA

EM

LC

EF &
EC

FE

CL

MT

AT

TF

PD

FA

RA

BR

ST

BF

HA

EL

IDX

Gear Components (Cont'd)

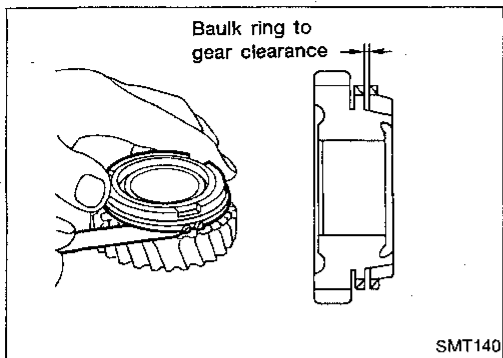

- Measure wear of baulk rings.
 - a. Measure clearance between baulk ring and gear.
- Clearance between baulk ring and gear:**
Refer to SDS, MT-57.

If the clearance is smaller than the wear limit, replace baulk ring.

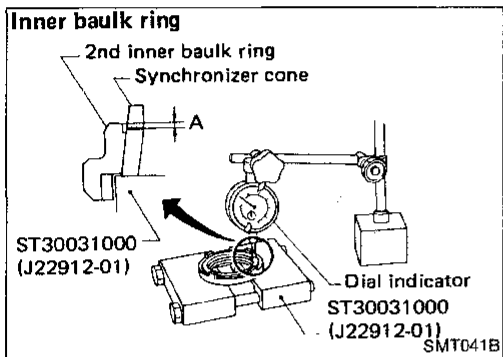

- Measure wear of 2nd baulk rings.
- a. Place baulk rings in position on synchronizer cone.
- b. While holding baulk rings against synchronizer cone as far as it will go, measure dimensions "A" and "B".

Unit: mm (in)

Dimension	Standard	Wear limit
A	0.6 - 1.1 (0.024 - 0.043)	0.2 (0.008)
B	0.7 - 0.9 (0.028 - 0.035)	

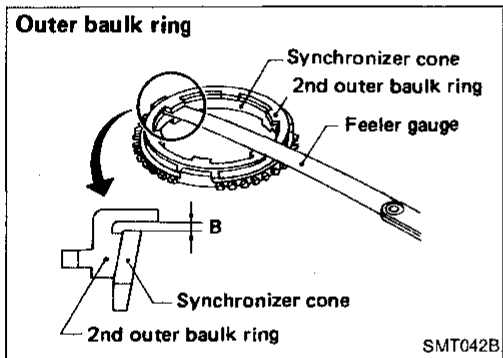

- c. If dimension "A" or "B" is smaller than the wear limit, replace baulk ring.

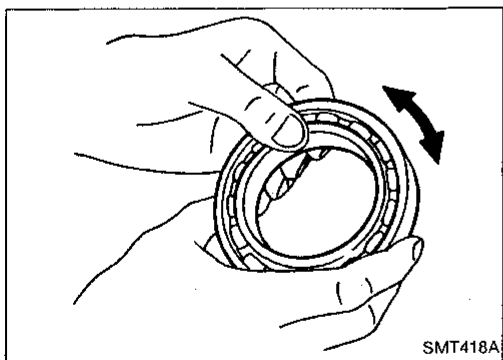

BEARINGS

- Make sure bearings roll freely and are free from noise, crack, pitting or wear.

Gear Components

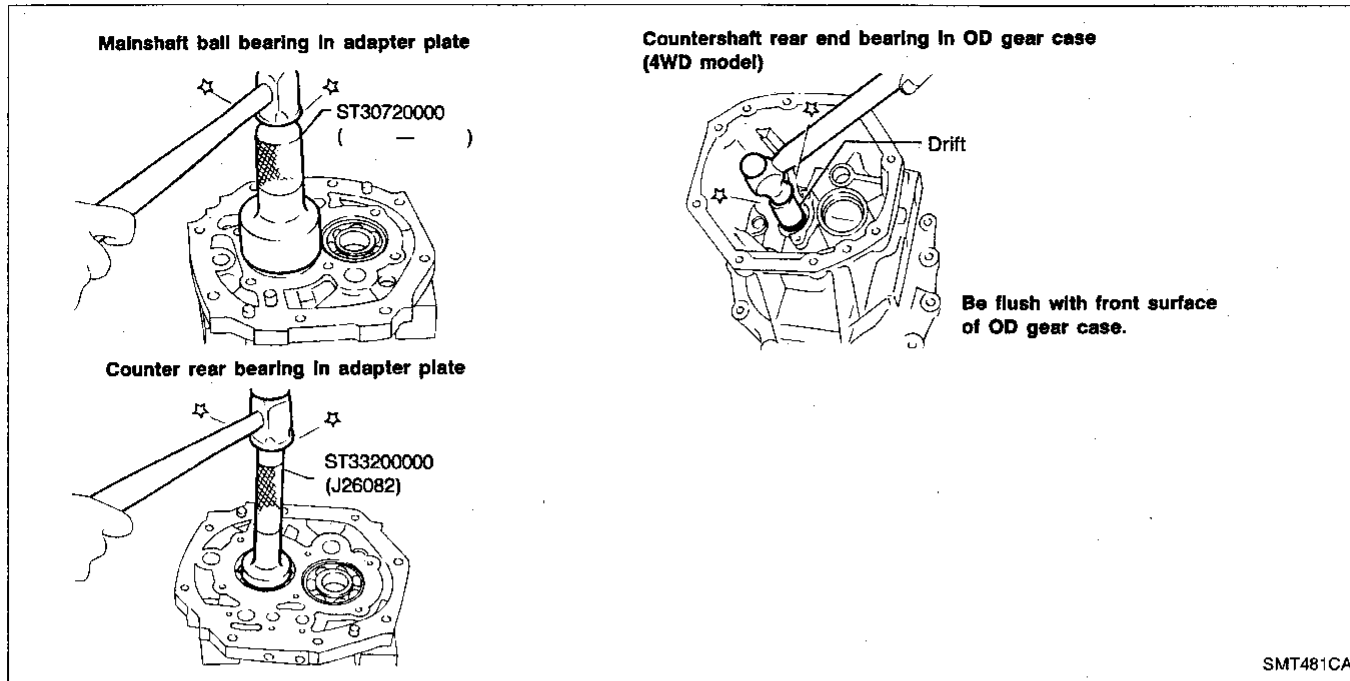

GI
 MA
 EM
 LC
 EF & EC
 FE
 CL

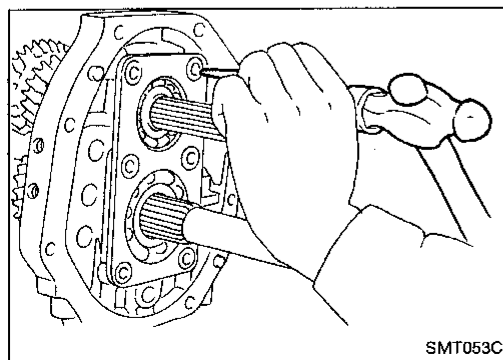
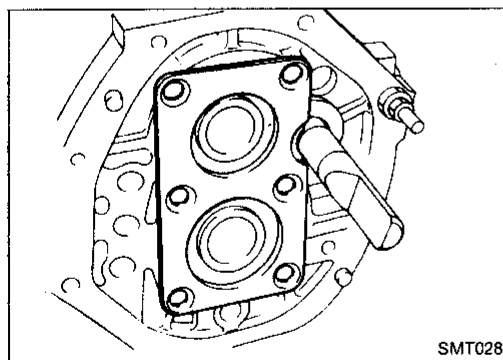
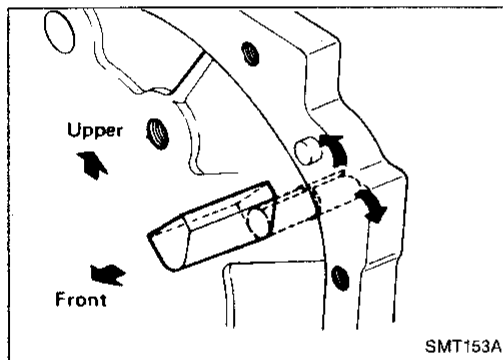

1. Install bearings into case components.
2. Assemble adapter plate parts.
 - Install oil gutter on adapter plate and expand on rear side.
- Install bearing retainer.
 - a. Insert reverse shaft, then install bearing retainer.
 - b. Tighten each screw, then stake each at two points.

MT
 AT
 TF
 PD
 FA
 RA
 BR
 ST
 BF
 HA
 EL
 IDX

Gear Components (Cont'd)

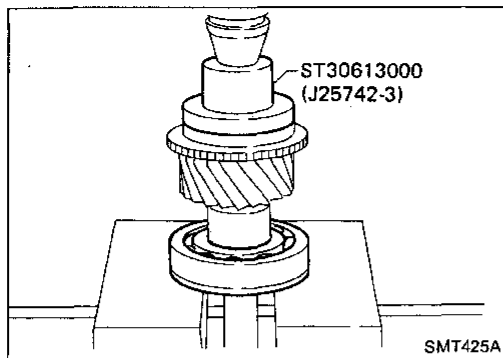

3. Install main drive gear bearing.
 - a. Press main drive gear bearing.
 - b. Install main drive gear spacer.

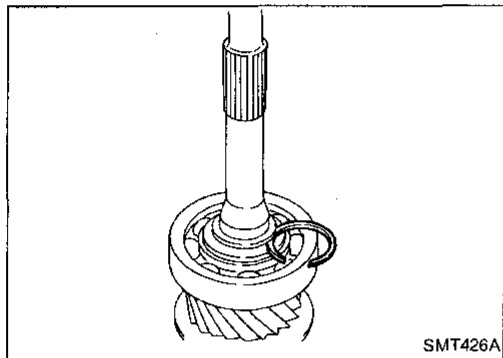

- c. Select proper main drive gear snap ring to minimize clearance of groove and install it.
 - Allowable clearance of groove:**
0 - 0.13 mm (0 - 0.0051 in)
 - Main drive gear snap ring:**
Refer to SDS, MT-57.

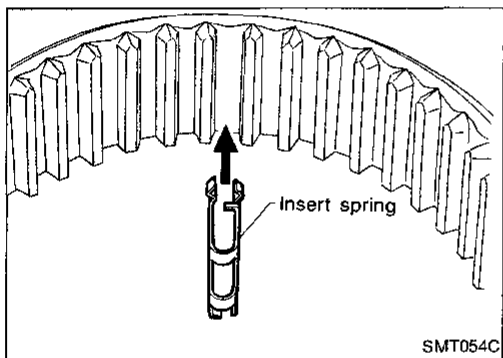

4. Assemble synchronizers.
 - 1st synchronizer

Check coupling sleeve and synchronizer hub orientation.

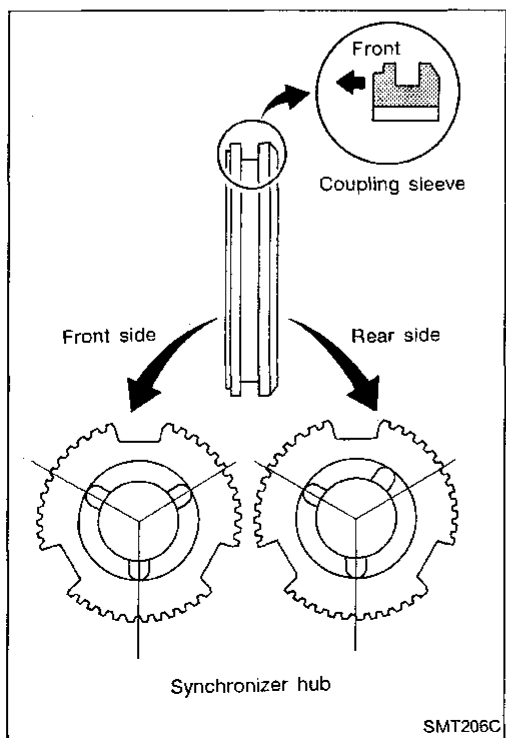

Gear Components (Cont'd)

- 2nd double baulk ring type synchronizer

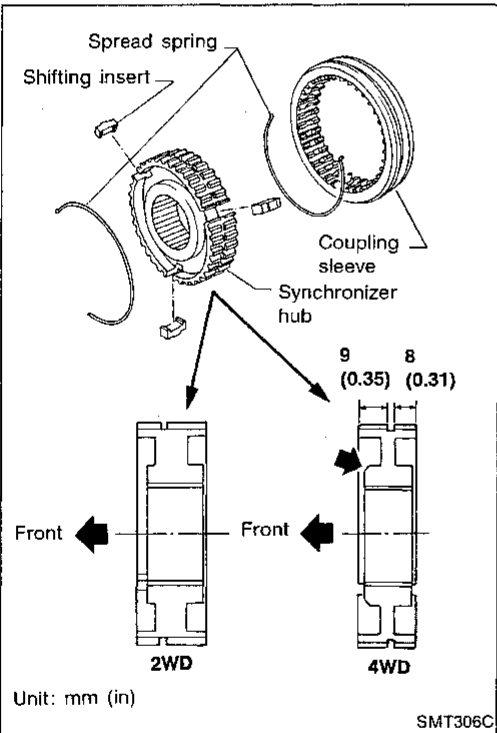
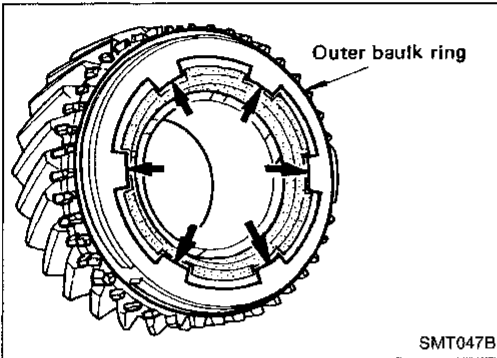
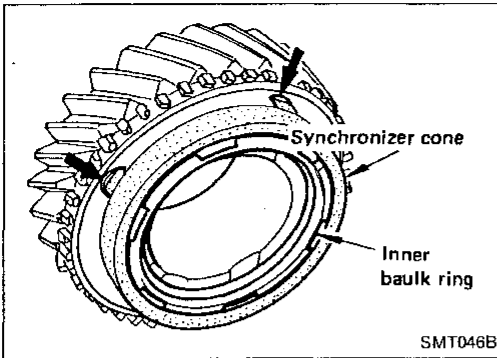

- 3rd & 4th synchronizer

The 3 gutters of synchronizer should be at the rear.

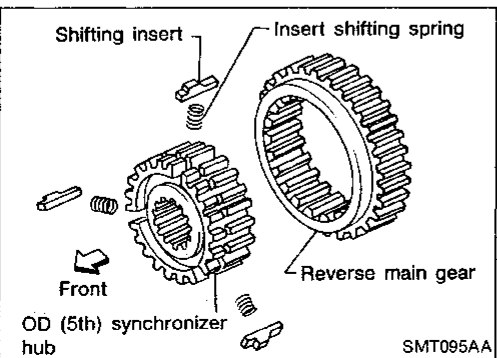

- OD & reverse synchronizer (2WD model)

GI

MA

EM

LC

EF &
EC

FE

CL

MT

AT

TF

PD

FA

RA

BR

ST

BF

HA

EL

IDX

Gear Components (Cont'd)

(4WD model)

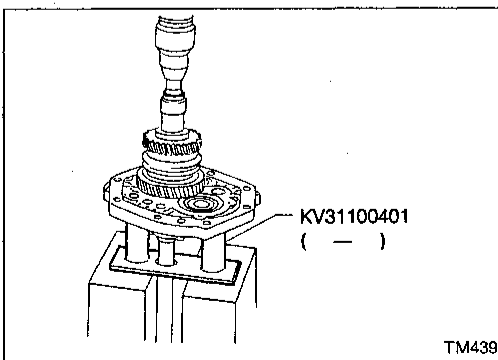
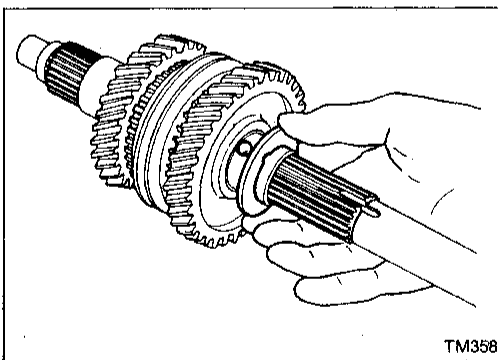
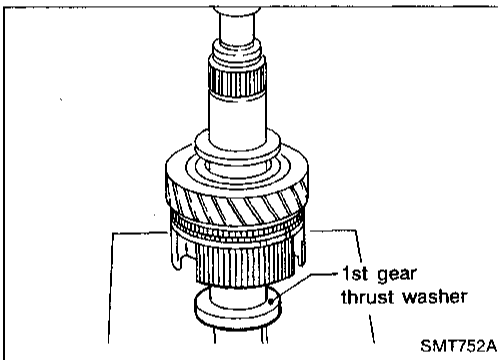
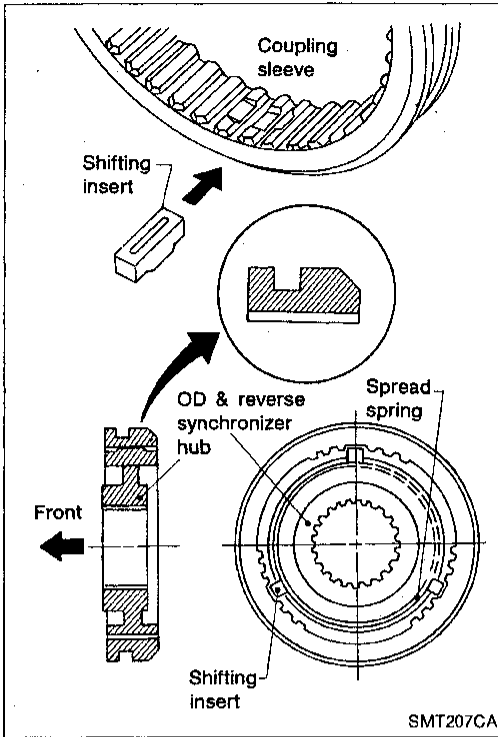

5. Install front side components on mainshaft.
 - a. Assemble 2nd main gear, needle bearing and 1st & 2nd synchronizer assembly, then press 1st gear bushing on mainshaft.
 - b. Install 1st main gear.

- c. Install steel ball and 1st gear washer.
 Apply multi-purpose grease to steel ball and 1st gear washer before installing.

6. Install mainshaft and counter gear on adapter plate and main drive gear on mainshaft as follows.
 - a. Press mainshaft assembly to adapter plate with Tool.

Gear Components (Cont'd)

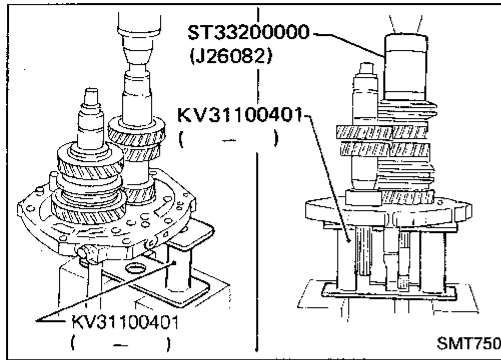

- b. Press counter gear into adapter plate with Tool.
- c. Install 3rd main gear and then press 3rd & 4th synchronizer assembly.
- **Pay attention to direction of 3rd & 4th synchronizer.**

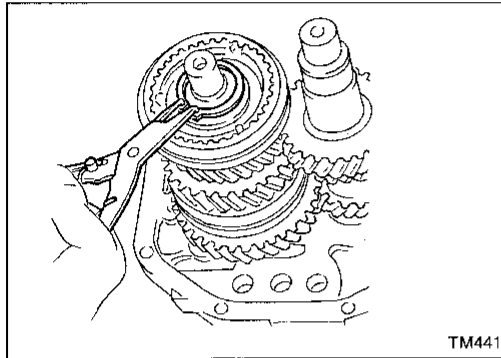

- d. Install thrust washer on mainshaft and secure it with mainshaft front snap ring. Select proper snap ring to minimize clearance of groove in mainshaft.

Allowable clearance of groove:
0 - 0.18 mm (0 - 0.0071 in)

Mainshaft front snap ring:
Refer to SDS, MT-57.

- e. Apply gear oil to mainshaft pilot bearing and install it on mainshaft.

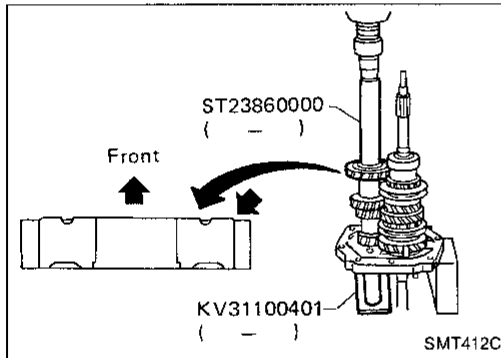

- f. Press counter drive gear with main drive gear with Tool.
- **Pay attention to direction of counter drive gear.**

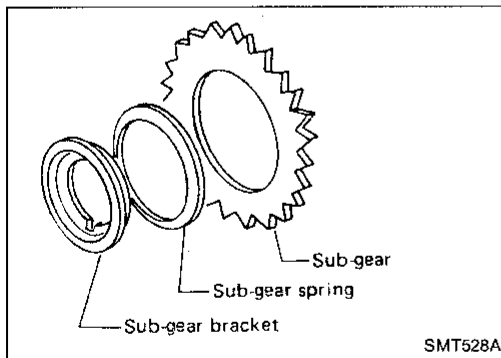

- g. Install sub-gear components.
- (1) Install sub-gear and sub-gear bracket on counter drive gear and then select proper snap ring to minimize clearance of groove in counter gear.

Allowable clearance of groove:
0 - 0.18 mm (0 - 0.0071 in)

Counter drive gear snap ring:
Refer to SDS, MT-57.

- (2) Remove snap ring, sub-gear bracket and sub-gear from counter gear.
- (3) Reinstall sub-gear, sub-gear spring and sub-gear bracket.

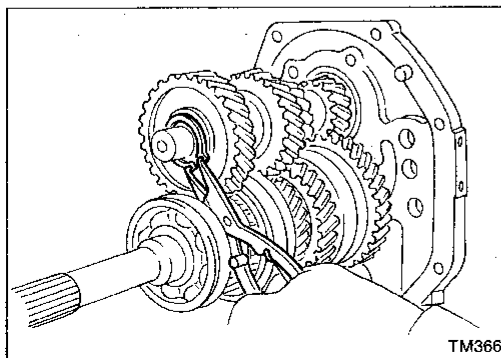

- h. Install selected counter drive gear snap ring.

GI

MA

EM

LC

EF &
EC

FE

CL

MT

AT

TF

PD

FA

RA

BR

ST

BF

HA

EL

IDX

Gear Components (Cont'd)

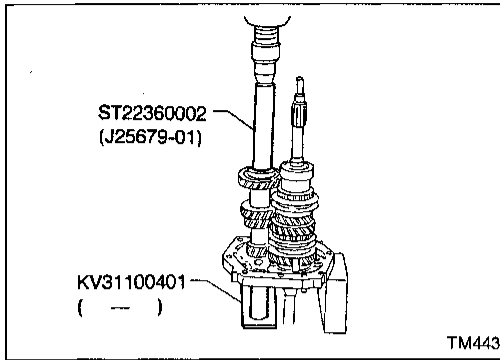

i. Press counter gear front bearing onto counter gear.

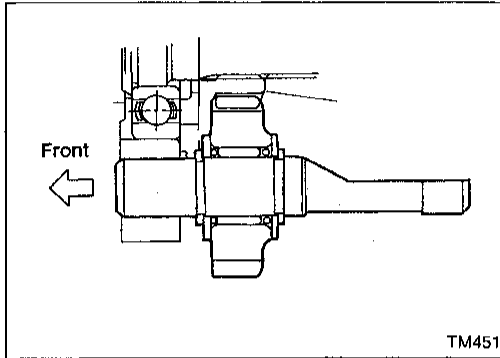

7. Install rear side components on mainshaft and counter gear as follows:
 a. Install reverse idler gear to reverse idler shaft with spacers, snap rings and needle bearing.

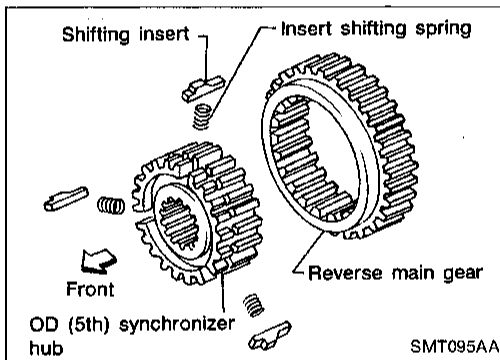

b. Install insert retainer and OD synchronizer to mainshaft. (2WD model)
Pay attention to direction of hub.

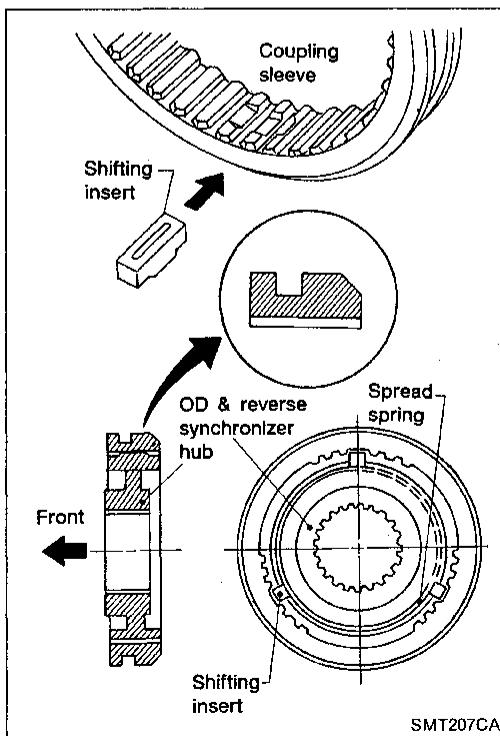

b. Install bushing and OD & reverse synchronizer to mainshaft. (4WD model)
Pay attention to direction of hub.

Gear Components (Cont'd)

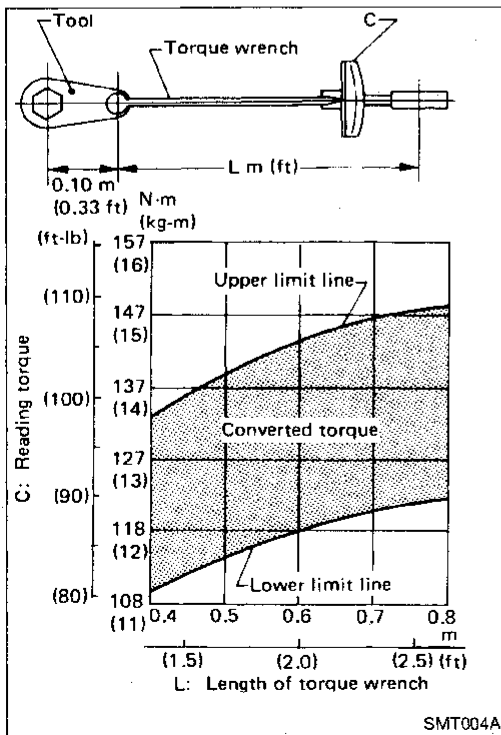
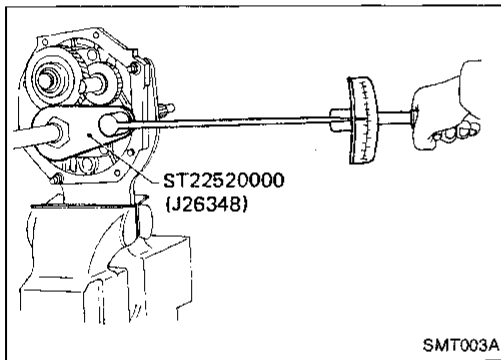
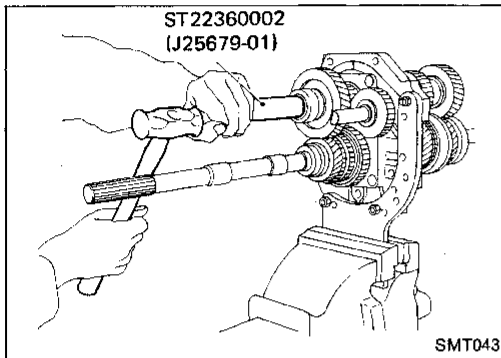
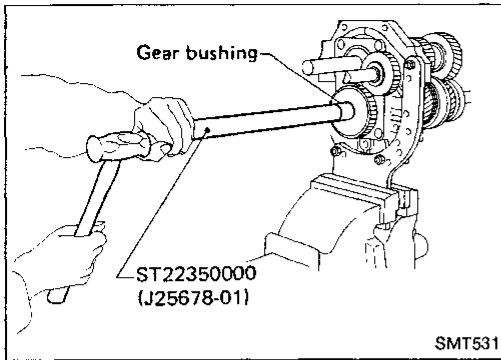

- c. Install OD gear bushing with Tool.
- d. Install OD main gear and needle bearing.
- e. Install spacer, reverse counter gear and OD counter gear.
 - **OD main gear and OD counter gear should be handled as a matched set.**
- f. Install washer, roller bearing, steel roller and thrust washer.
- g. Tighten mainshaft lock nut temporarily.
 - **Always use new lock nut.**

- h. Install countershaft rear end bearing with Tool.

- 8. Mesh 2nd and reverse gears, then tighten mainshaft lock nut with Tool.

- Use the left chart when deciding the reading torque. (Length of torque wrench vs. setting or reading torque)
- 9. Tighten countershaft lock nut.
 - **Always use new lock nut.**

GI
MA
EM
LC
EF & EC
FE
CL
MT
AT
TF
PD
FA
RA
BR
ST
BF
HA
EL
IDX

Gear Components (Cont'd)

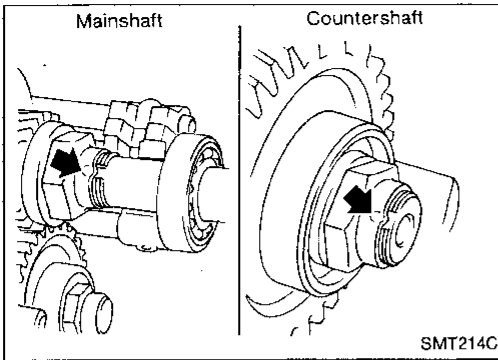

10. Stake mainshaft lock nut and countershaft lock nut with a punch.
11. Measure gear end play. For the description, refer to DIS-ASSEMBLY for Gear Components, MT-17.

Shift Control Components

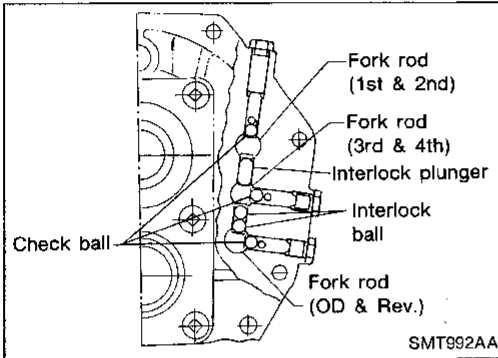

1. Install shift rods, interlock plunger, interlock balls and check balls.

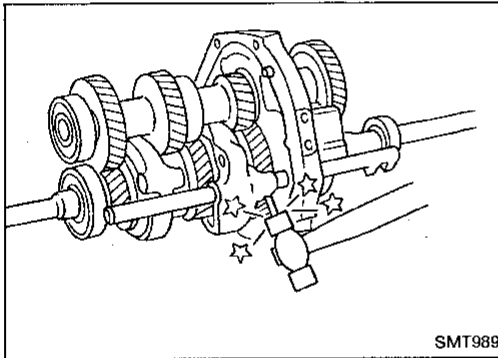

- a. 1st-2nd shift fork

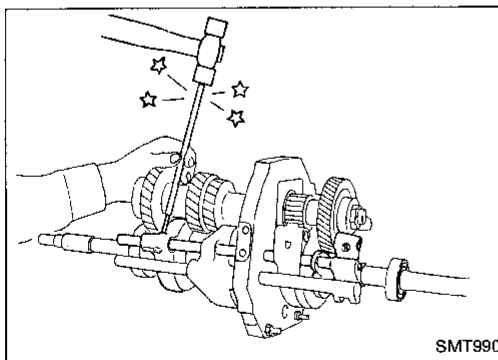

- b. 3rd-4th shift fork

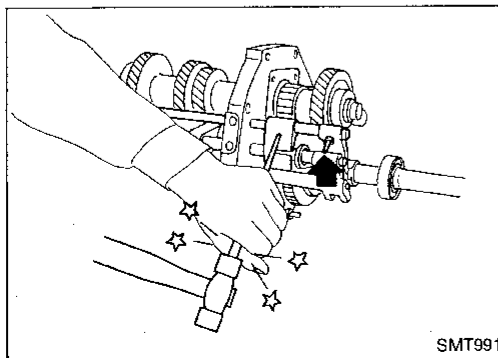

- c. OD-reverse shift fork or reverse shift fork

Shift Control Components (Cont'd)

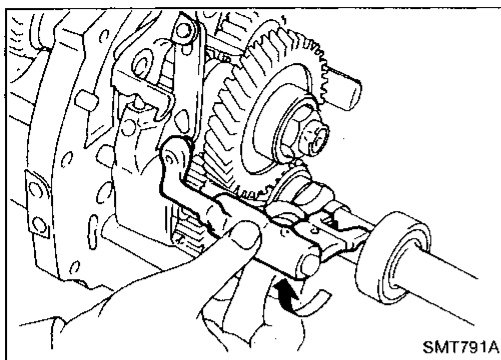

2. Install OD-rev. fork shaft by rotating OD-rev. bracket clockwise (2WD model).

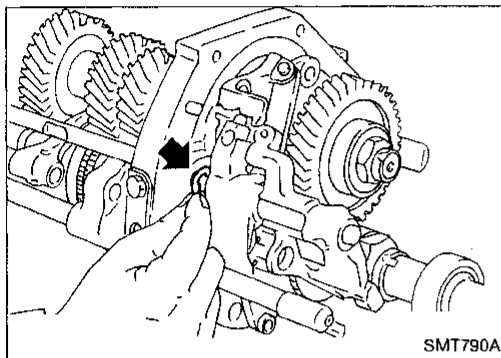

3. Install E-ring on OD-rev. fork rod (2WD model).

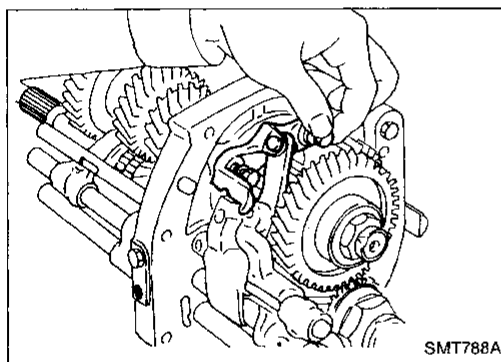

4. Install lever bracket securing bolt (2WD model).

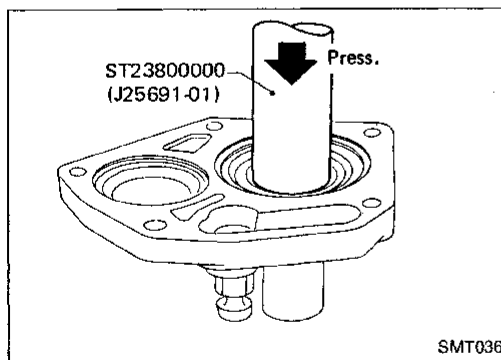

Case Components

1. Install front cover oil seal.
 - Apply multi-purpose grease to seal lip.

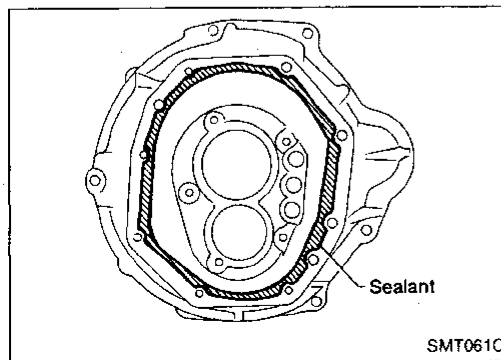

2. Apply sealant to mating surface of transmission case.

GI
MA
EM
LC
EF & EC
FE
CL
MT
AT
TF
PD
FA
RA
BR
ST
BF
HA
EL
IDX

Case Components (Cont'd)

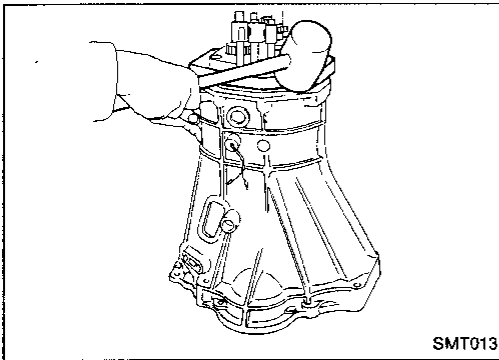

3. Slide gear assembly onto adapter plate by lightly tapping with a soft hammer.

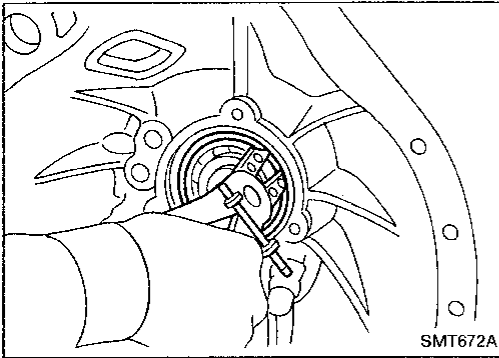

4. Install main drive bearing snap ring.

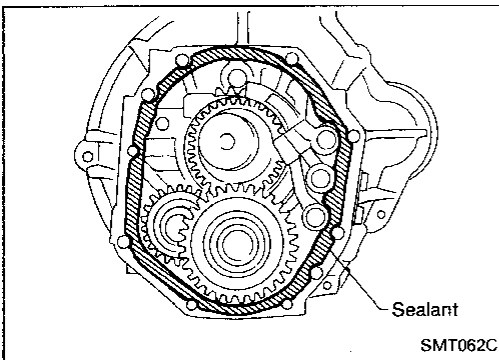

5. Apply sealant to mating surface of adapter plate.

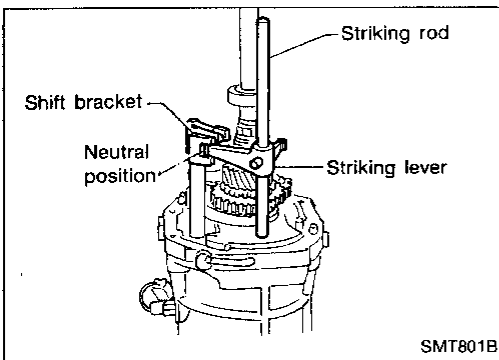

6. Set shift forks in neutral position.
7. Install striking lever onto adapter plate and align striking lever with shift brackets.

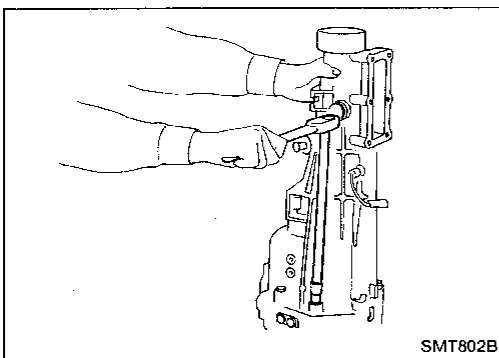

8. Install rear extension.
9. Fit main drive bearing snap ring.

Case Components (Cont'd)

10. Install striking arm retaining pin.

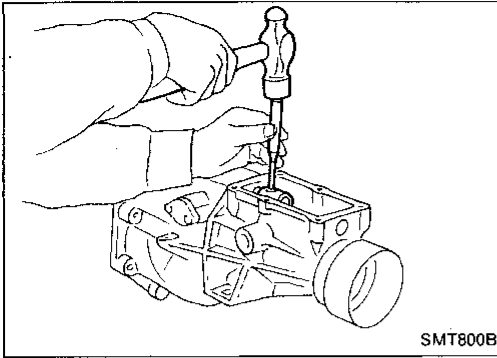

11. Select counter front bearing shim.

**Counter front bearing shim:
Refer to SDS, MT-58.**

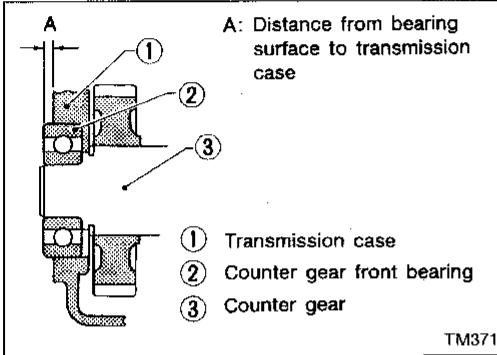

12. Install gasket and front cover.

13. Install return spring plugs, check ball, return springs and select check plunger.

14. Install control housing and gasket.

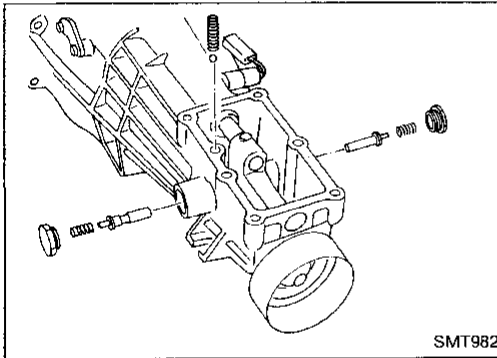

GI

MA

EM

LC

EF &
EC

FE

CL

MT

AT

TF

PD

FA

RA

BR

ST

BF

HA

EL

IDX

NOTE

Case Components

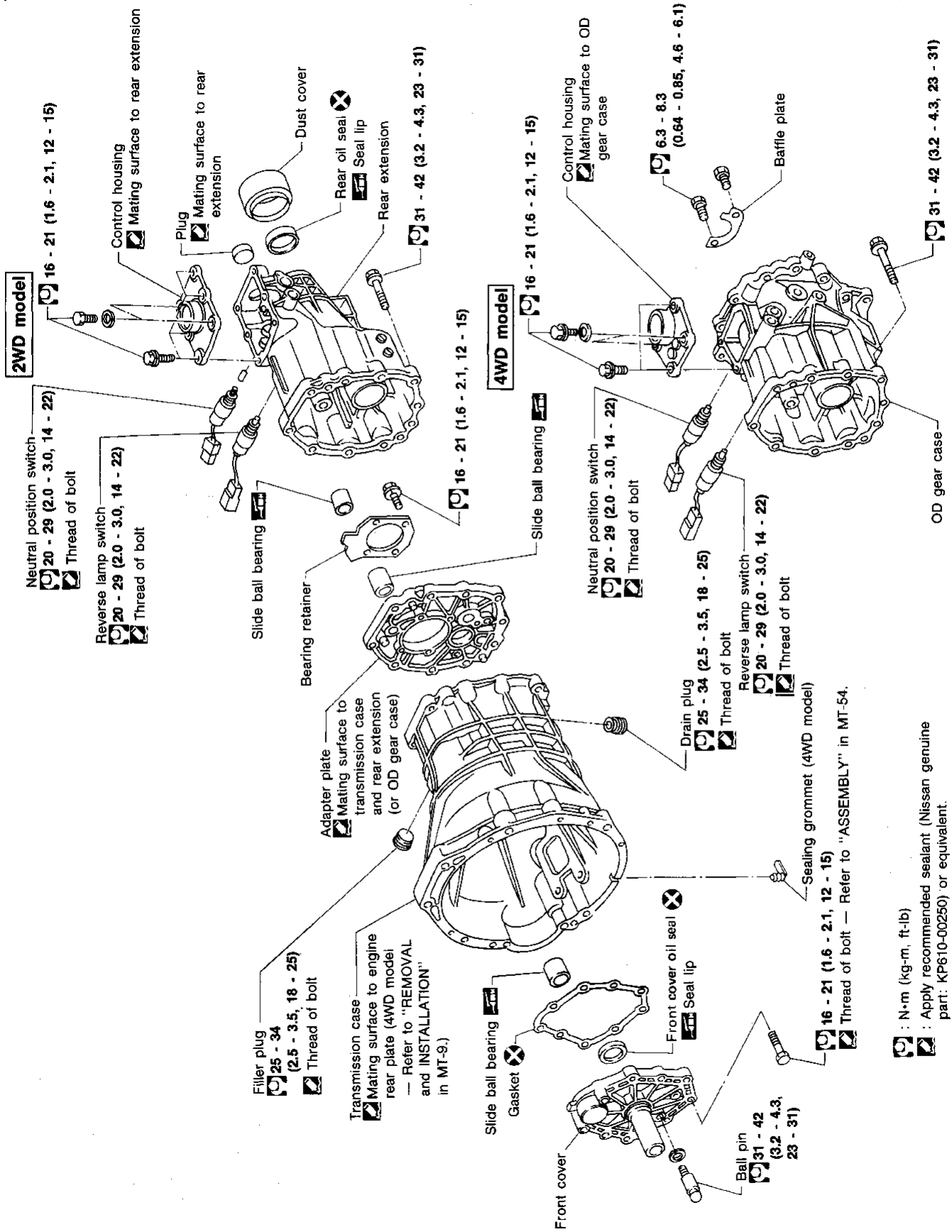

⊗ : N·m (kg-m, ft-lb)

⊠ : Apply recommended sealant (Nissan genuine part: KP610-00250) or equivalent.

GI
MA
EM
LC
EF & EC
FE
CL
MT
AT
TF
PD
FA
RA
BR
ST
BF
HA
EL

Gear Components

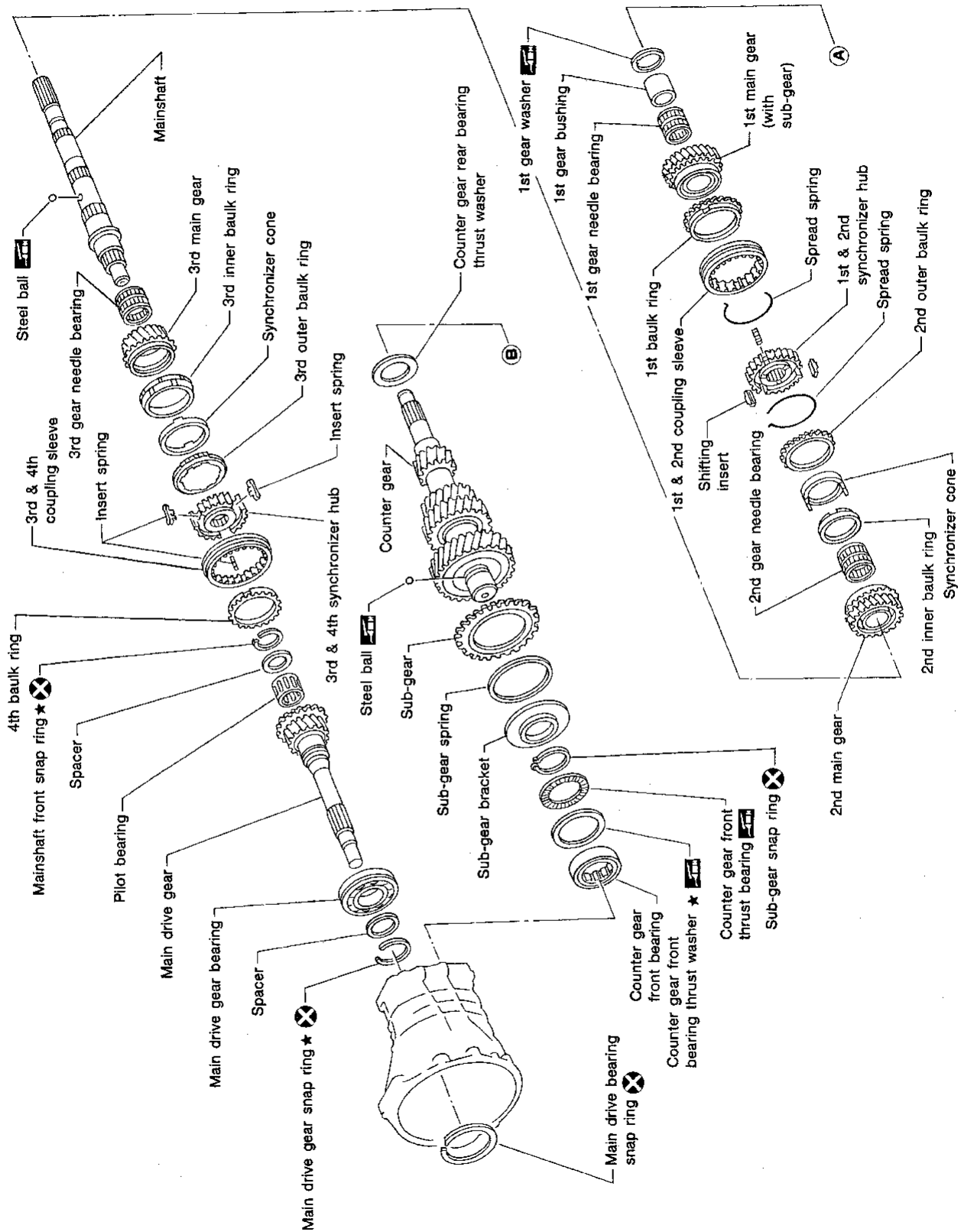

Shift Control Components

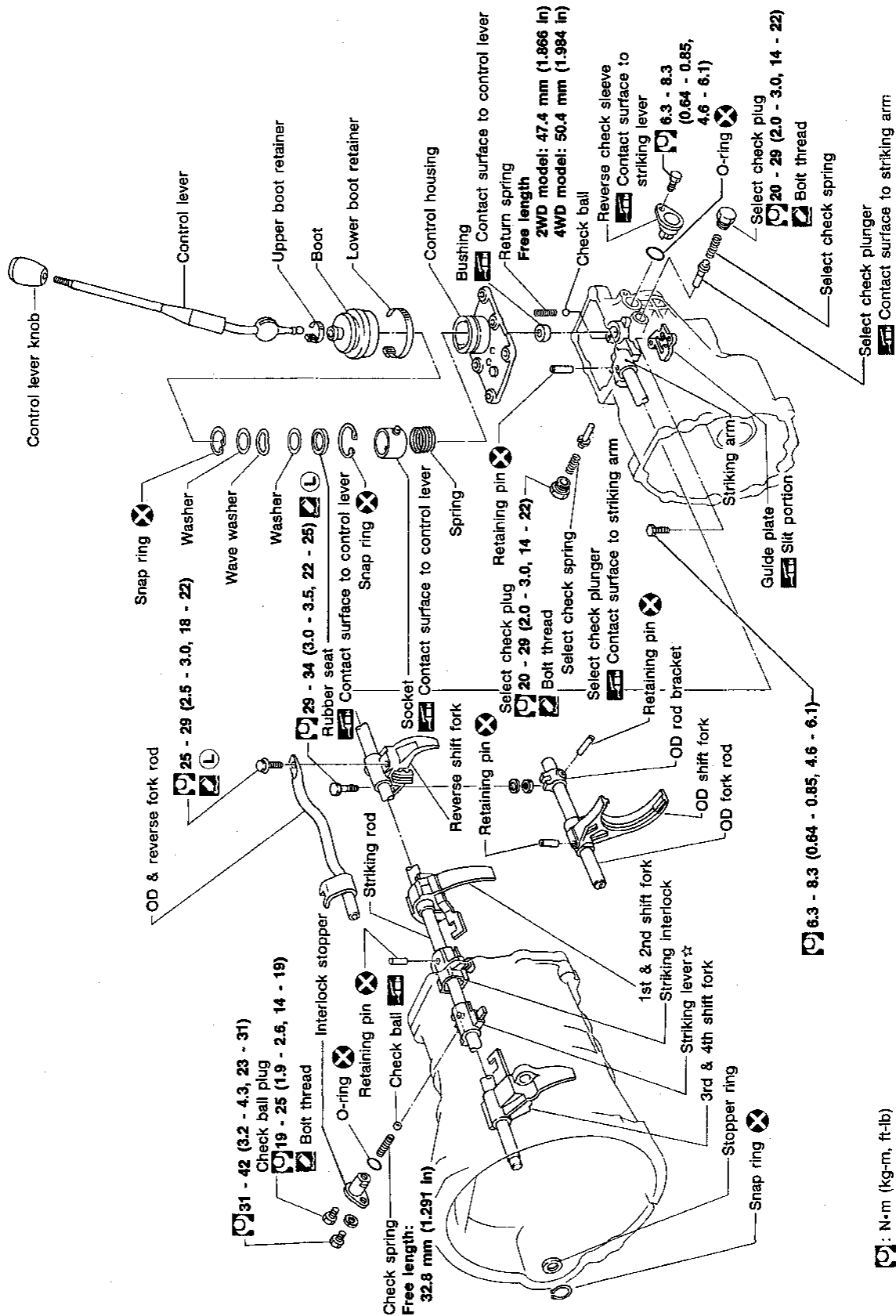

- : N·m (kg-m, ft-lb)
- : Apply recommended sealant (Nissan genuine part: KP610-00250) or equivalent.
- : Apply locking sealant.
- ☆ : Pay attention to its direction.

Case Components

1. Remove check ball plug, check spring and check ball. Then remove interlock stopper.
If interlock assembly is removed as a unit, the check ball can fall into transmission case.

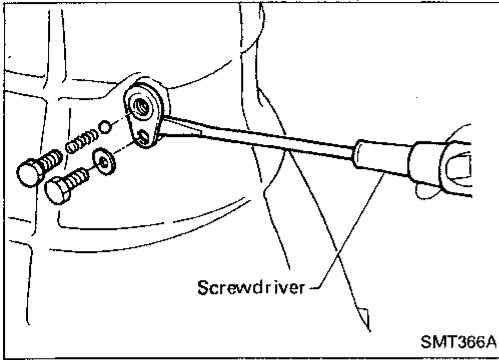

2. Remove control housing, return spring and check ball.

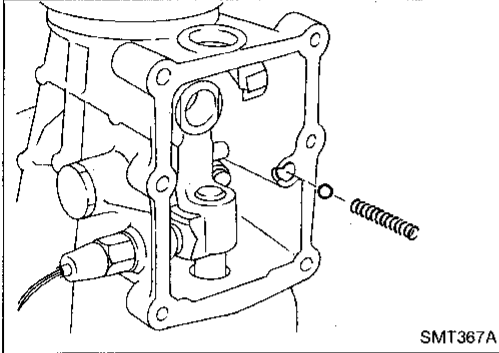

3. Drive out retaining pin from striking arm.

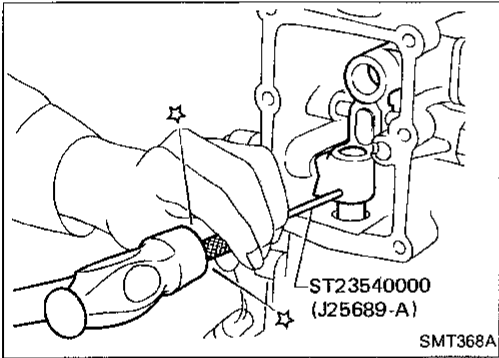

4. Remove rear extension (or OD gear case) together with striking arm by tapping lightly.

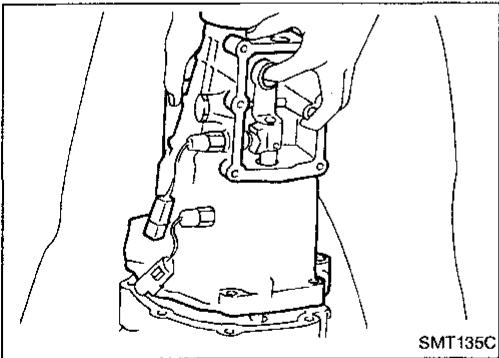

5. Remove front cover and gasket.

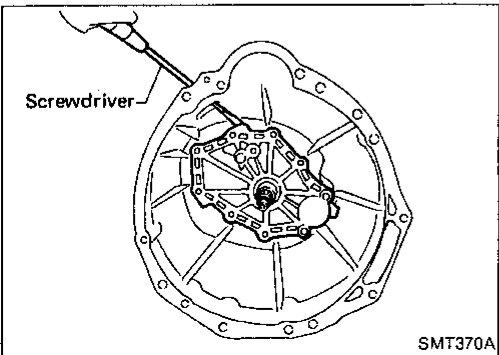

GI

MA

EM

LC

EF &
EC

FE

CL

MT

AT

TF

PD

FA

RA

BR

ST

BF

HA

EL

IDX

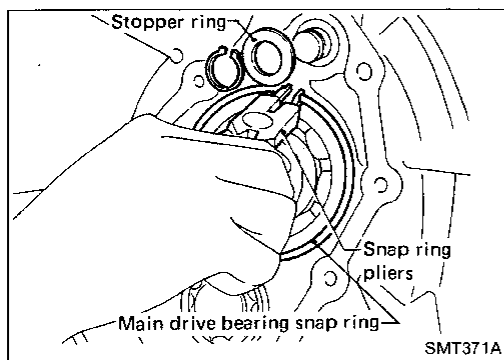
Case Components (Cont'd)

6. Remove stopper ring and main drive bearing snap ring.

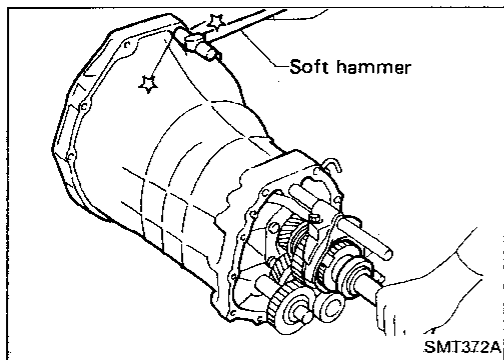

7. Remove transmission case by tapping lightly.

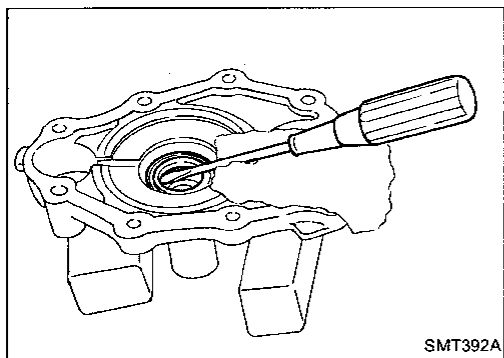

8. Remove front cover oil seal.

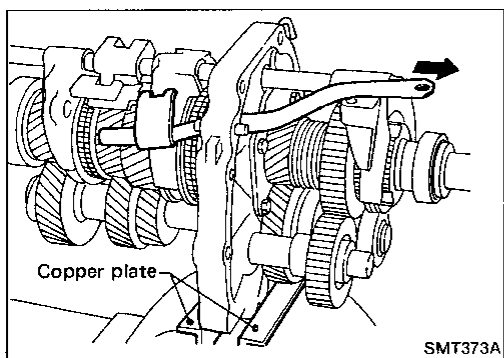
**Shift Control Components**

1. Mount adapter plate on vise.
2. Remove OD & reverse fork rod.

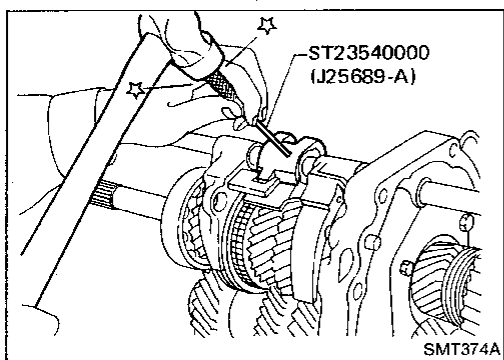

3. Drive out retaining pin from striking lever.
4. While pulling out striking rod, remove striking lever and striking interlock. Then remove 1st & 2nd, 3rd & 4th and reverse shift fork.

Shift Control Components (Cont'd)

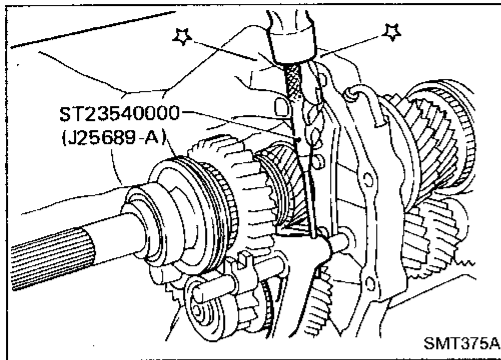

5. Drive out retaining pin from OD shift fork.
6. Pull out OD fork rod and then remove OD shift fork.

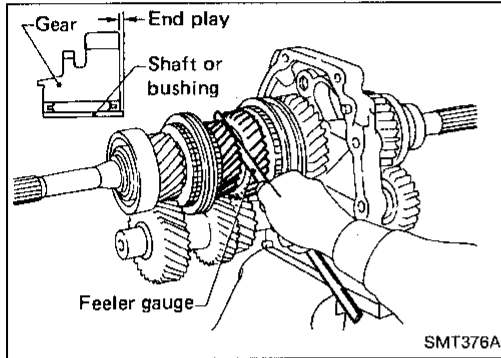

Gear Components

1. Before removing gears and shafts, measure each gear end play.

Gear end play:
Refer to SDS, MT-59.

- If not within specification, disassemble and check contact surface of gear to hub, washer, bushing, needle bearing and shaft.

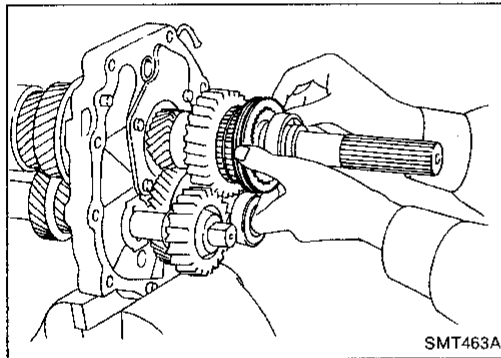

2. Remove rear side components on mainshaft and counter gear.
 - a. Remove reverse coupling sleeve.

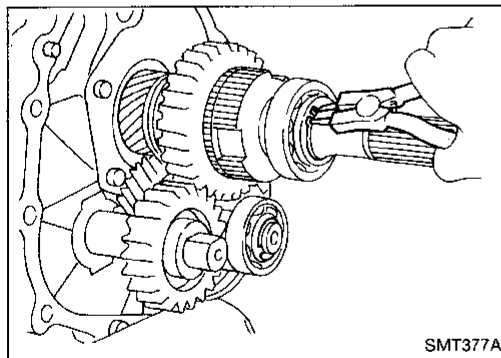

- b. Remove mainshaft rear snap ring and counter gear rear snap ring.
 - c. Remove C-ring holder and mainshaft C-rings from mainshaft. Use punch and hammer to remove C-rings.

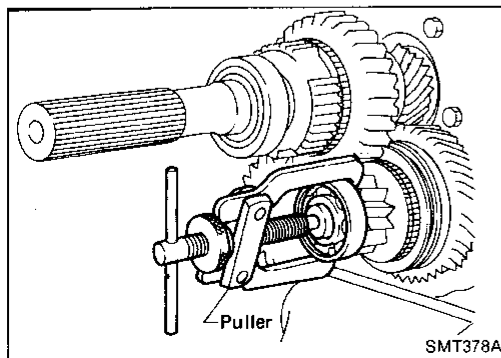

- d. Pull out counter gear rear end bearing.
 - e. Remove reverse idler gear and reverse idler thrust washers.

GI

MA

EM

LC

EF &
EC

FE

CL

MT

AT

TF

PD

FA

RA

BR

ST

BF

HA

EL

IDX

Gear Components (Cont'd)

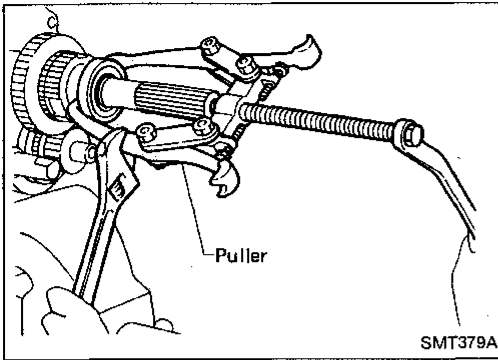

f. Pull out mainshaft rear bearing (2WD model).

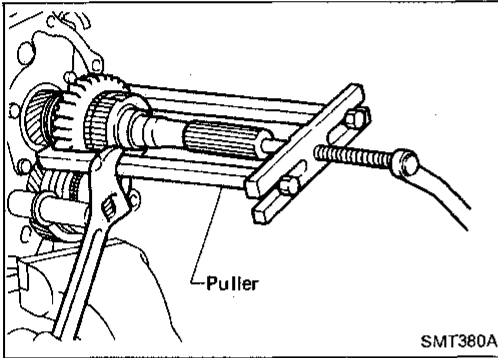

g. Pull out reverse main gear together with mainshaft spacer and reverse synchronizer hub. Then remove reverse gear needle bearings.

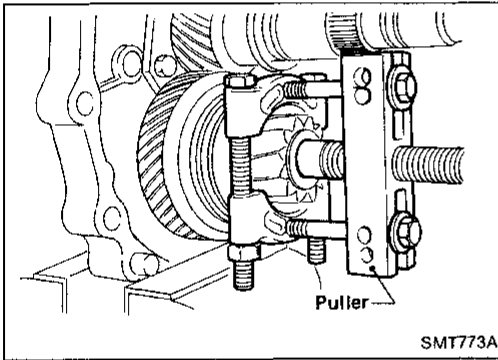

h. Pull out reverse counter gear.

i. Remove OD coupling sleeve together with OD baulk ring, reverse baulk ring and spring inserts.

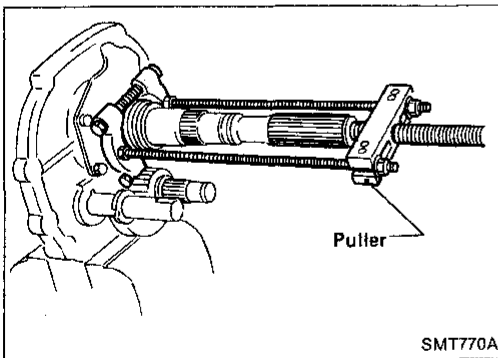

j. Pull out reverse gear bushing.

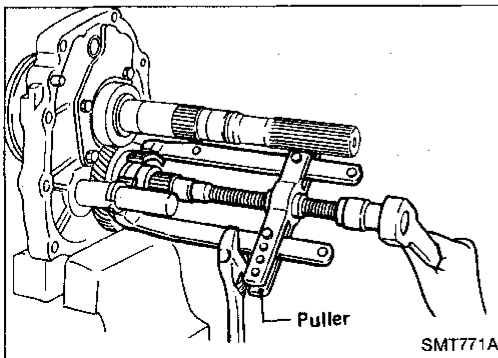

k. Pull out OD counter gear together with reverse cone.

Gear Components (Cont'd)

3. Press out mainshaft and counter gear alternately.

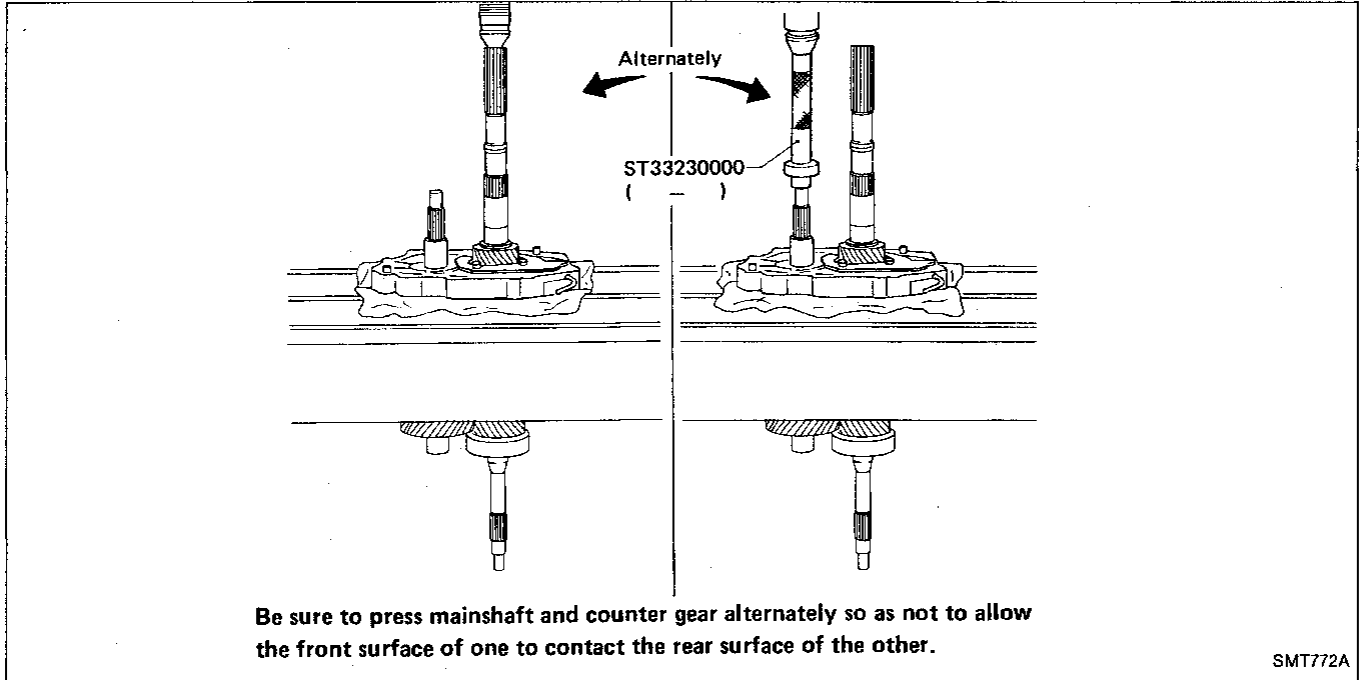

GI
MA
EM
LC
EF &
EC
FE
CL

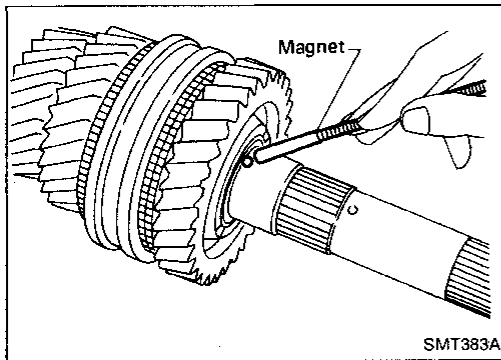

4. Remove front side components on mainshaft.

- a. Remove 1st gear washer and steel ball.
- b. Remove 1st main gear and 1st gear needle bearing.

MT

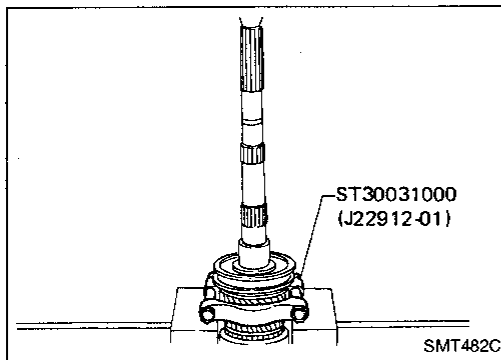

- c. Press out 2nd main gear together with 1st gear bushing and 1st & 2nd synchronizer assembly.
- d. Remove mainshaft front snap ring.

AT

TF

PD

FA

RA

BR

ST

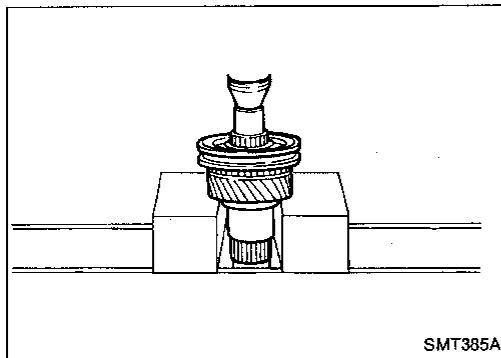

- e. Press out 3rd main gear together with 3rd & 4th synchronizer assembly and 3rd gear needle bearing.

BF

HA

EL

IDX

Gear Components (Cont'd)

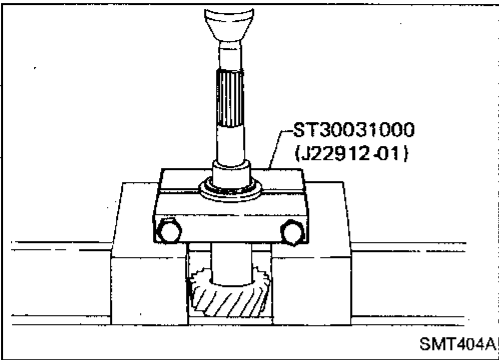

5. Remove front side components on counter gear.
 - a. Remove counter gear rear thrust bearing.

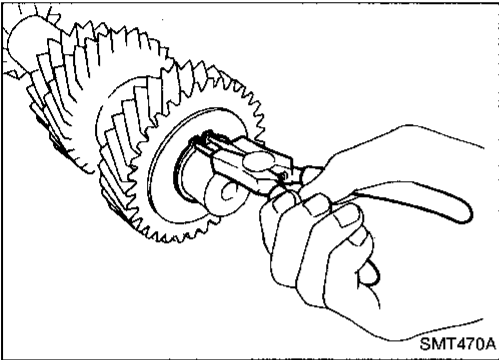

- b. Remove sub gear components.

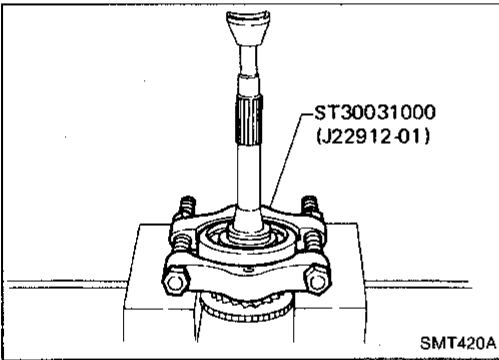

6. Remove main drive gear bearing.
 - a. Remove main drive gear snap ring and spacer.
 - b. Press out main drive gear bearing.

7. Remove bearings from case components.

Counter gear front bearing in transmission case

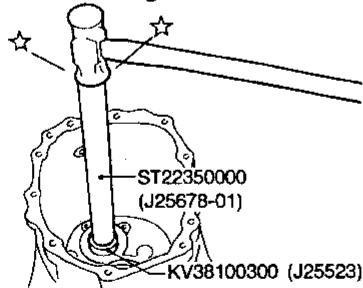

SMT388A

Mainshaft front bearing in adapter plate

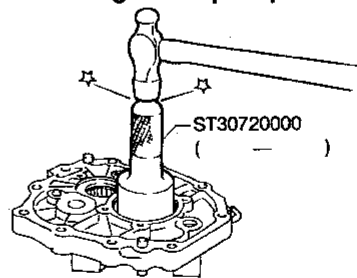

SMT396A

Counter gear rear end bearing in OD gear case (4WD model)

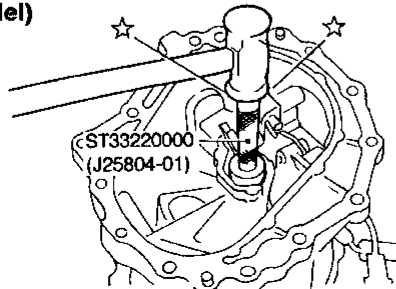

SMT390A

Counter gear rear bearing in adapter plate

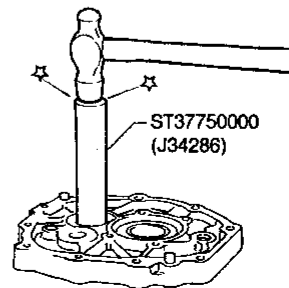

SMT483CA

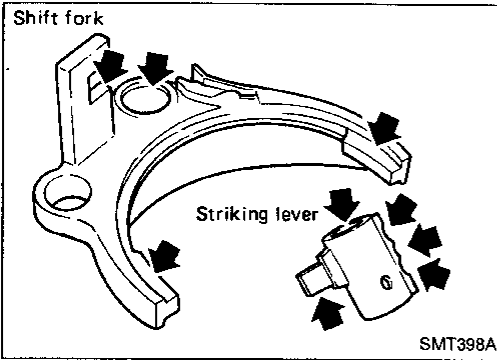

Shift Control Components

- Check contact surface and sliding surface for wear, scratches, projections or other damage.

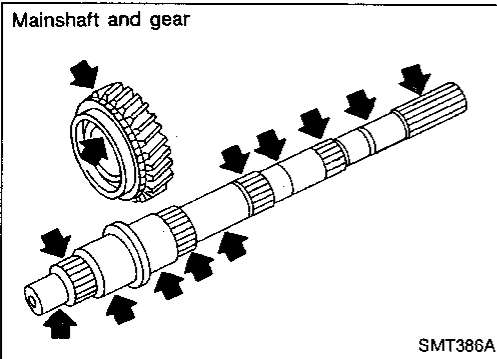

Gear Components

GEARS AND SHAFTS

- Check shafts for cracks, wear or bending.
- Check gears for excessive wear, chips or cracks.

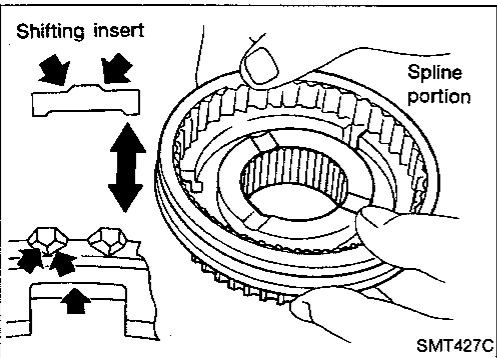
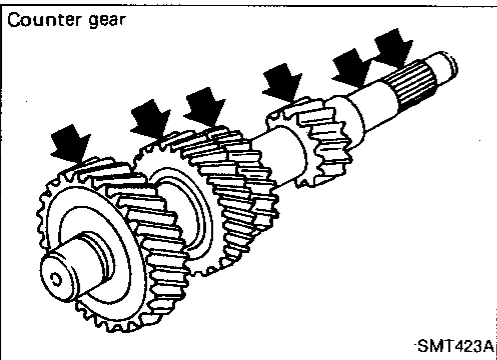

SYNCHRONIZERS

- Check spline portion of coupling sleeves, hubs, and gears for wear or cracks.
- Check baulk rings for cracks or deformation.
- Check shifting inserts for wear or deformation.
- Check insert springs for deformation.

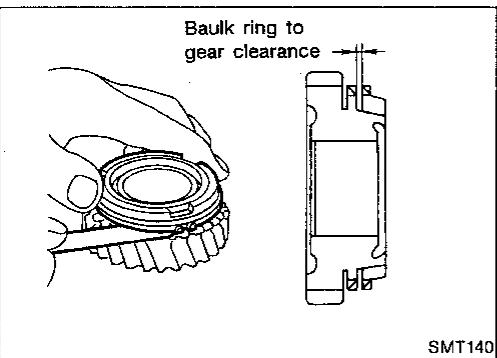

Clearance between baulk ring and gear

- Measure wear of main drive, 1st and OD baulk rings.

Unit: mm (in)

	Standard	Wear limit
1st	1.05 - 1.3 (0.0413 - 0.0512)	0.7 (0.028)
Main drive	1.05 - 1.3 (0.0413 - 0.0512)	0.7 (0.028)
OD	1.05 - 1.3 (0.0413 - 0.0512)	0.7 (0.028)

If the clearance is smaller than the wear limit, replace baulk ring.

GI

MA

EM

LC

EF & EC

FE

CL

MT

AT

TF

PD

FA

RA

BR

ST

BF

HA

EL

IDX

Gear Components (Cont'd)

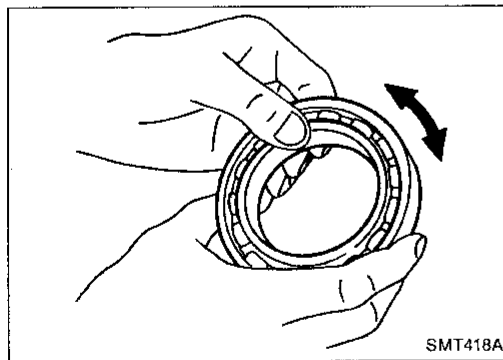
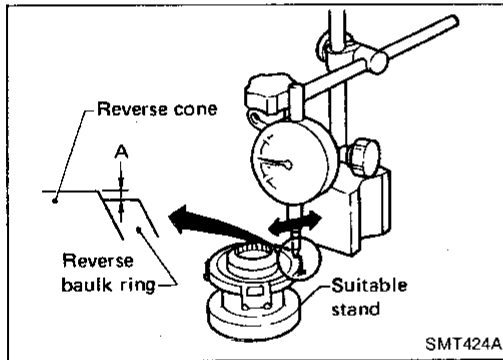
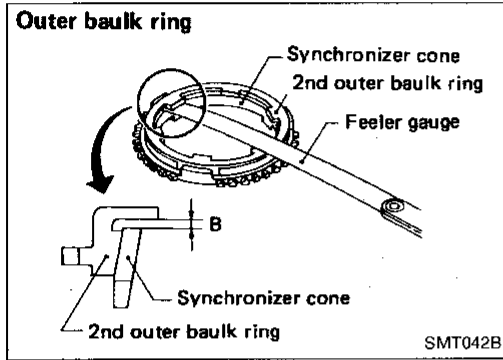
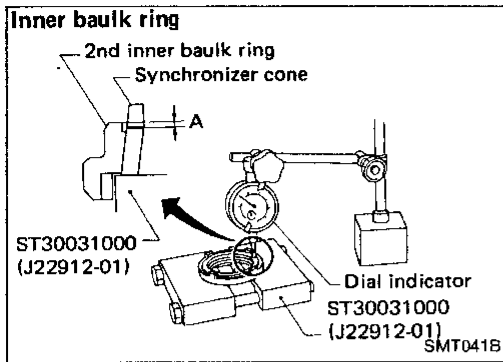

- Measure wear of 2nd and 3rd baulk rings.
 - a. Place baulk rings in position on synchronizer cone.
 - b. While holding baulk rings against synchronizer cone as far as it will go, measure dimensions "A" and "B".

Unit: mm (in)

Dimension	Standard	Wear limit
A	0.6 - 1.1 (0.024 - 0.043)	0.2 (0.008)
B	0.7 - 0.9 (0.028 - 0.035)	

- c. If dimension "A" or "B" is smaller than the wear limit, replace baulk ring.

- Measure wear of reverse baulk ring.
 - a. Place baulk ring in position on reverse cone.
 - b. While holding baulk ring against reverse cone as far as it will go, measure dimension "A" with dial indicator.

Dimension "A":
Standard -0.1 to 0.35 mm (-0.0039 to 0.0138 in)
Wear limit 0.7 mm (0.028 in)
 - c. If dimension "A" is larger than the wear limit, replace baulk ring.

BEARINGS

- Make sure bearings roll freely and are free from noise, crack, pitting or wear.

Gear Components

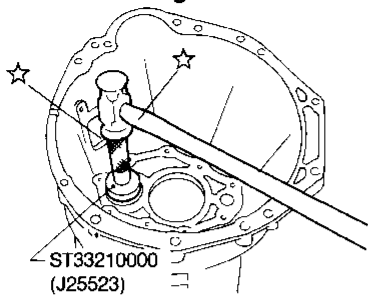
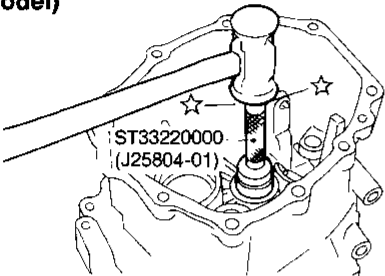
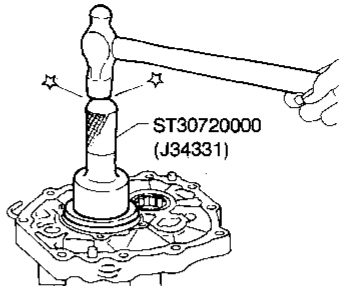
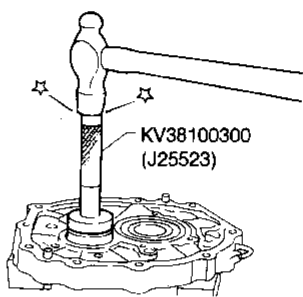
<p>Counter gear front bearing in transmission case</p>  <p>ST33210000 (J25523)</p> <p>Counter gear rear end bearing in OD gear case (4WD model)</p>  <p>ST33220000 (J25804-01)</p> <p>Be flush with front surface of OD gear case.</p> <p>SMT389A</p> <p>SMT391A</p>	<p>Mainshaft front bearing in adapter plate</p>  <p>ST30720000 (J34331)</p> <p>Counter gear rear bearing in adapter plate</p>  <p>KV38100300 (J25523)</p> <p>SMT397A</p> <p>SMT484CA</p>
--	---

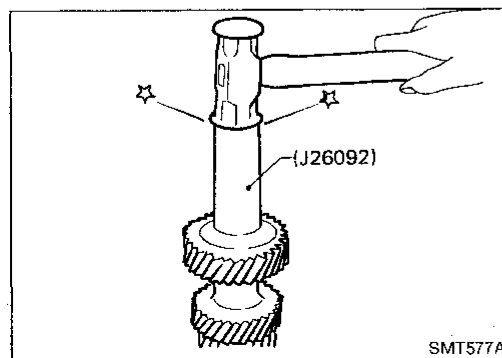
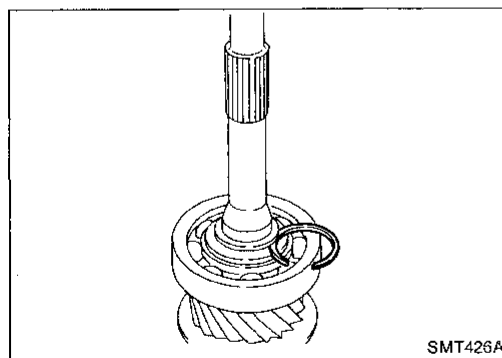
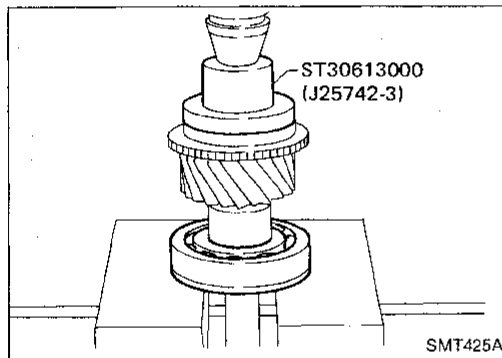

1. Install bearings into case components.
2. Install main drive gear bearing.
 - a. Press main drive gear bearing.
 - b. Install main drive gear spacer.
 - c. Select proper main drive gear snap ring to minimize clearance of groove.

Allowable clearance of groove:
0 - 0.1 mm (0 - 0.004 in)

Main drive gear snap ring:
Refer to SDS, MT-59.
 - d. Install selected snap ring on main drive gear.
3. Install components on counter gear.
 - a. Install sub-gear components.

When installing sub-gear snap ring, tap sub-gear snap ring into position on counter gear.

GI
MA
EM
LC
EF & EC
FE
CL
MT
AT
TF
PD
FA
RA
BR
ST
BF
HA
EL
IDX
533

Gear Components (Cont'd)

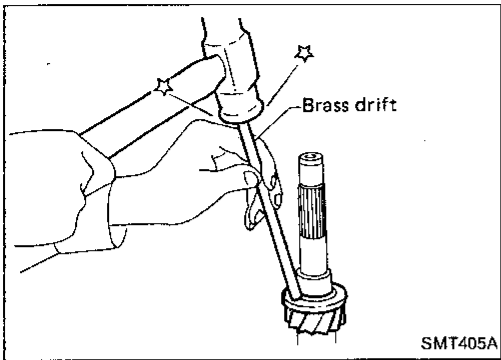

b. Install counter gear rear thrust bearing.

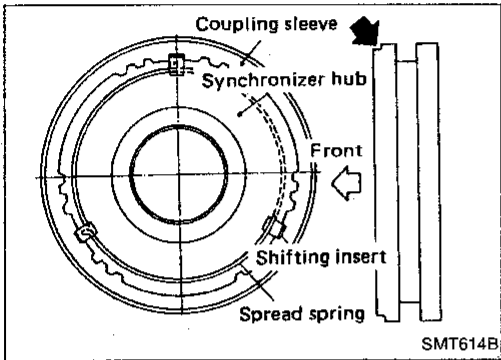

4. Install front side components on mainshaft.
a. Assemble 1st & 2nd synchronizer.

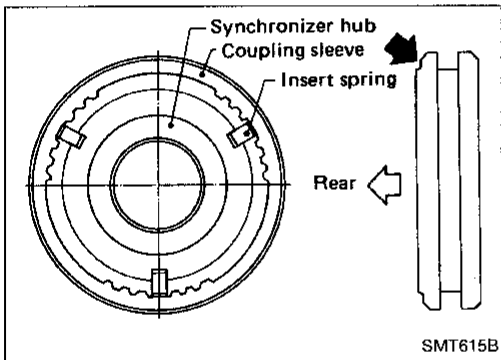

b. Assemble 3rd & 4th synchronizer.

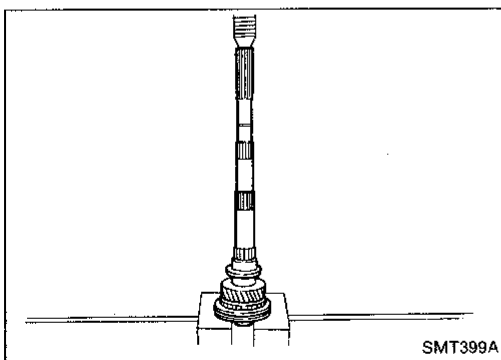

c. Press on 3rd & 4th synchronizer assembly together with 3rd main gear and 3rd gear needle bearing.
Pay attention to direction of synchronizer assembly.

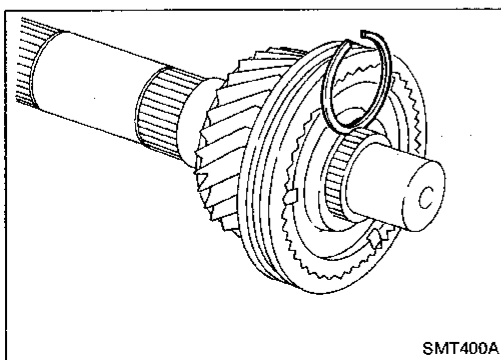

d. Select proper snap ring to minimize clearance of groove.
Allowable clearance of groove:
0 - 0.1 mm (0 - 0.004 in)
Mainshaft front snap ring:
Refer to SDS, MT-59.
e. Install selected snap ring on mainshaft.

Gear Components (Cont'd)

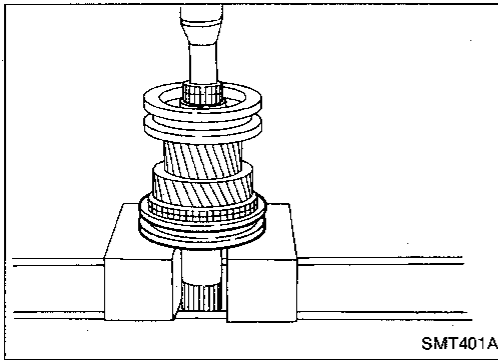

- f. Press on 1st & 2nd synchronizer assembly together with 2nd main gear and 2nd gear needle bearing.

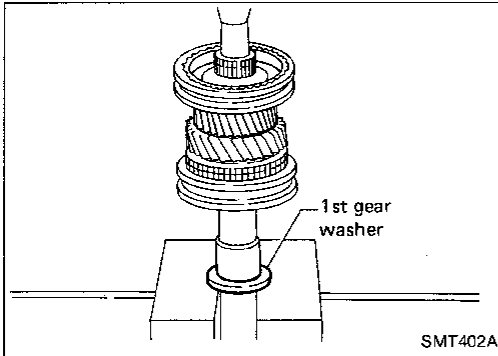

- g. Press on 1st gear bushing using 1st gear washer.
- h. Install 1st main gear and needle bearing.

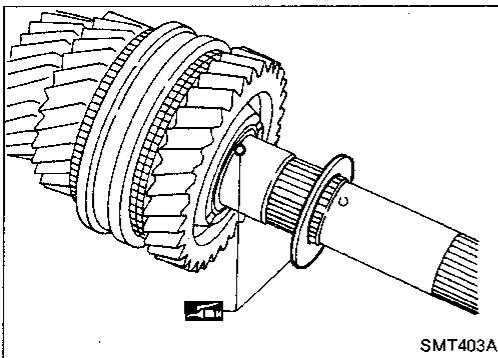

- i. Install steel ball and 1st gear washer.
Apply multi-purpose grease to steel ball and 1st gear washer before installing.

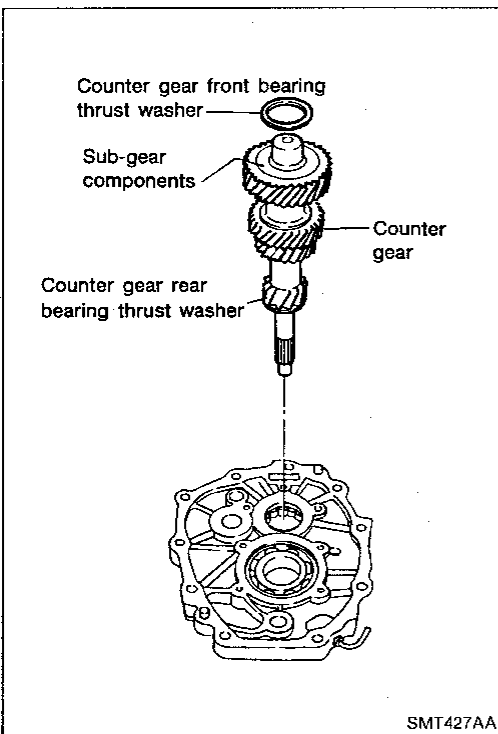

- 5. Select proper counter gear front bearing thrust washer when replacing transmission case, counter gear, counter gear thrust bearing or sub-gear components.
 - a. Install counter gear with sub-gear components, counter gear front and rear bearing thrust washer on adapter plate.
 - b. Remove counter gear front bearing thrust washer from transmission case.
 - c. Place adapter plate and counter gear assembly in transmission case (case inverted).

GI

MA

EM

LC

EF &
EC

FE

CL

MT

AT

TF

PD

FA

RA

BR

ST

BF

HA

EL

IDX

Gear Components (Cont'd)

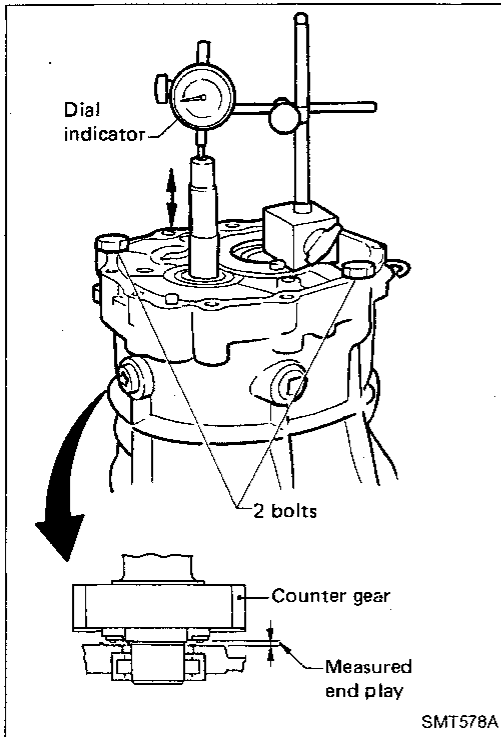

- d. Tighten adapter plate to transmission case using 2 bolts.
- e. Place dial indicator on rear end of counter gear.
- f. Move counter gear up and down and measure dial indicator deflection.
- g. Select proper thrust washer using table below as a guide.

Counter gear end play:

0.10 - 0.25 mm (0.0039 - 0.0098 in)

Table for selecting proper counter gear front bearing thrust washer:

Refer to SDS, MT-60.

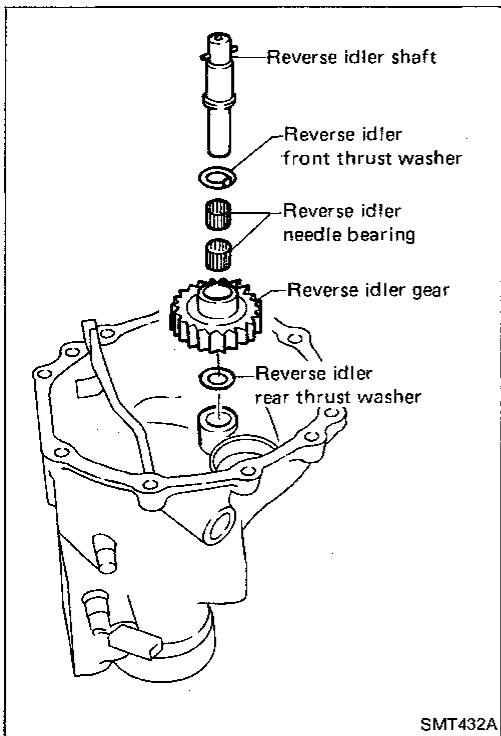

- 6. Select proper reverse idler rear thrust washer when replacing rear extension (or OD gear case), reverse idler gear, reverse idler shaft or reverse idler thrust washer.
- a. Install reverse idler gear, reverse idler needle bearings, reverse idler thrust washers and reverse idler shaft into rear extension (or OD gear case).

When replacing reverse idler rear washer, install either A or B.

Reverse idler rear thrust washer:

Refer to SDS, MT-60.

Gear Components (Cont'd)

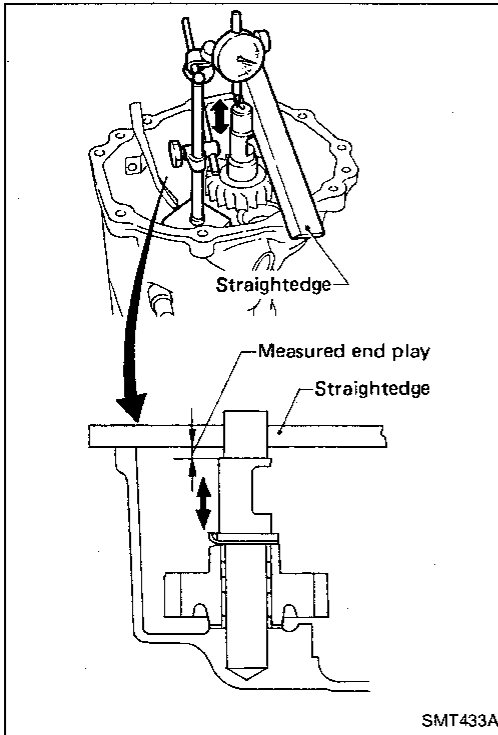

- b. Place dial indicator on front end of reverse idler shaft.
- c. Put straightedge on front surface of rear extension (or OD gear case) as a stopper of reverse idler shaft.
- d. Move reverse idler shaft up and down and measure reverse idler gear end play.

Reverse idler gear end play:

0.30 - 0.53 mm (0.0118 - 0.0209 in)

- e. If not within specification, replace reverse idler rear thrust washer with the other (A or B) and check again.

GI
MA
EM
LC
EF &
EC
FE
CL

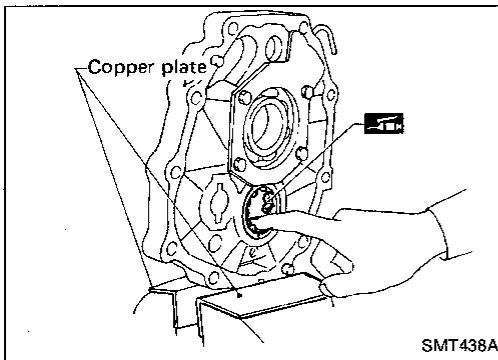

- 7. Install mainshaft and counter gear on adapter plate and main drive gear on mainshaft.
- a. Mount adapter plate on vise and apply multi-purpose grease to counter gear rear bearing.

MT
AT
TF
PD

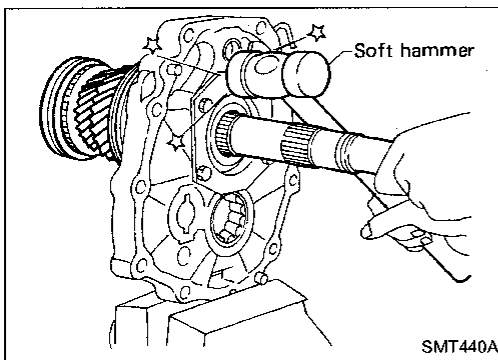

- b. Install mainshaft a little on mainshaft front bearing.
To allow for installation of counter gear, do not install mainshaft completely.

FA
RA
BR
ST

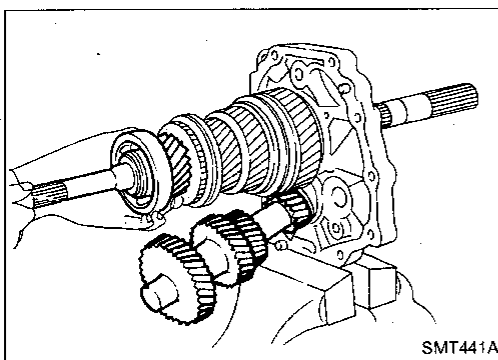

- c. Install counter gear on counter gear rear bearing and install main drive gear, pilot bearing and spacer on mainshaft.

HA
EL
IDX

Gear Components (Cont'd)

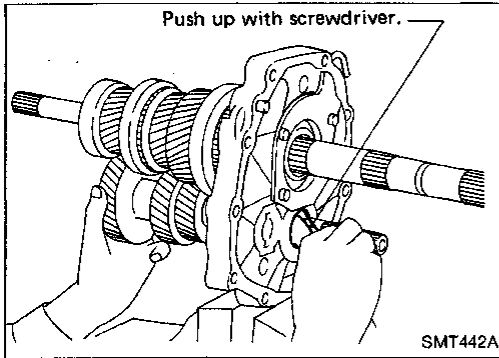

When installing counter gear into counter gear rear bearing, push up on upper roller of counter gear rear bearing with screwdriver.

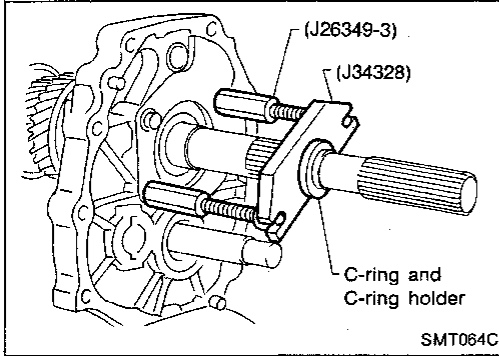

- d. Install Tools (J26349-3) onto adapter plate and C-ring and C-ring holder on mainshaft.
- e. Install Tool (J34328) on mainshaft.

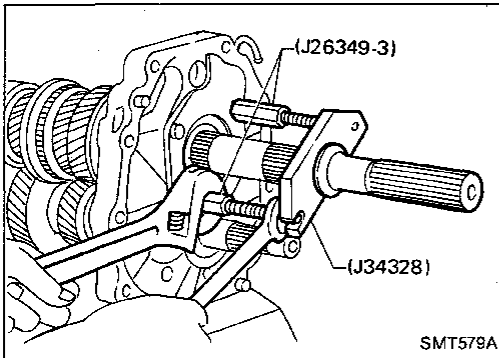

- f. Install mainshaft and counter gear completely by extending length of J26349-3.

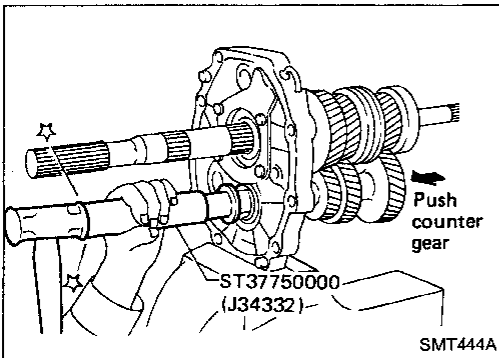

- 8. Install rear side components on mainshaft and counter gear.
 - a. Install OD gear bushing while pushing on the front of counter gear.

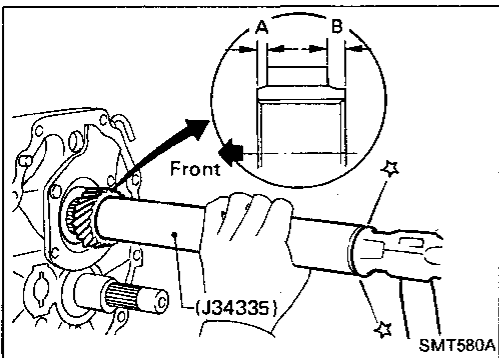

- b. Install OD main gear.
 - Pay attention to direction of OD main gear. (B is wider than A as shown at left.)**
- c. Install adapter plate with gear assembly onto transmission case.
- d. Install OD gear needle bearing and then install OD counter gear and reverse idler shaft.

Gear Components (Cont'd)

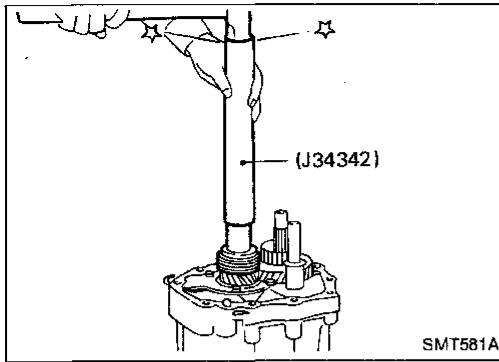

e. Install reverse gear bushing with speedometer drive gear (2WD model).

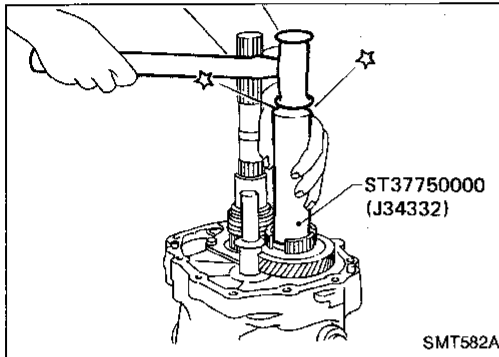

f. Install reverse cone.

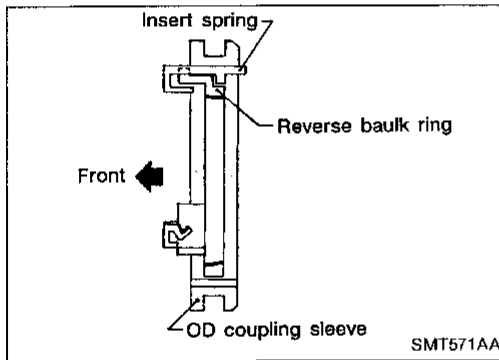

g. Install insert springs and reverse baulk ring on OD coupling sleeve. Then install them and OD baulk ring on OD counter gear.

Pay attention to direction of OD coupling sleeve.

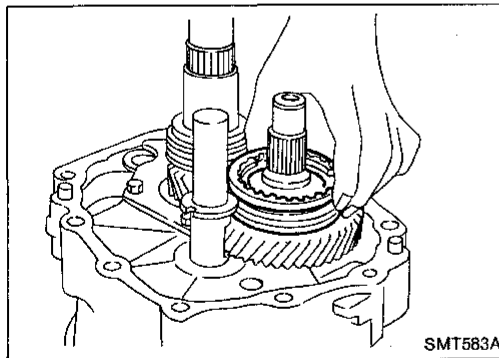

h. Install reverse counter gear.

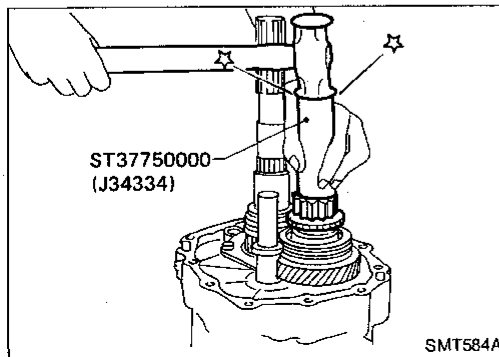

i. Install reverse gear needle bearing and then install reverse main gear, reverse idler gear and reverse idler thrust washers.

GI

MA

EM

LC

EF &
EC

FE

CL

MT

AT

TF

PD

FA

RA

BR

ST

BF

HA

EL

IDX

Gear Components (Cont'd)

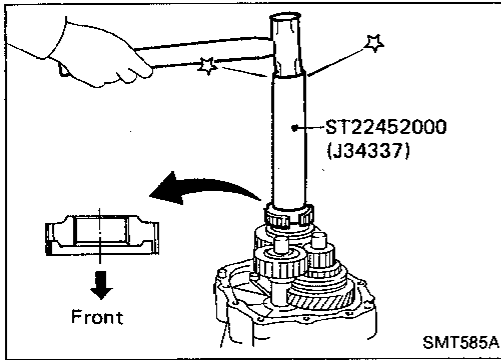

- j. Install reverse hub.
Pay attention to its direction.

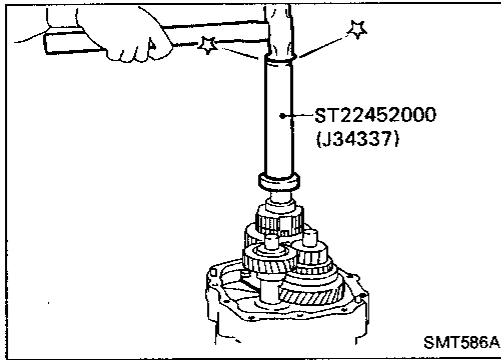

- k. Install mainshaft spacer and mainshaft rear bearing (2WD model).

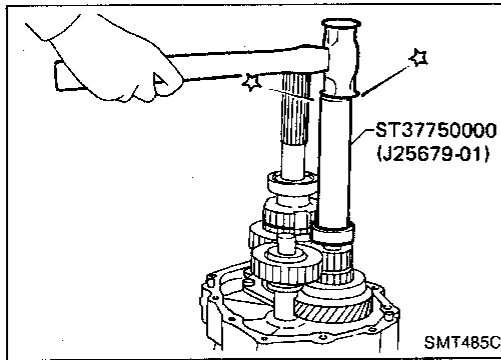

- l. Install counter gear rear end bearing.
- m. Separate adapter plate from transmission case and mount adapter plate on vice again.

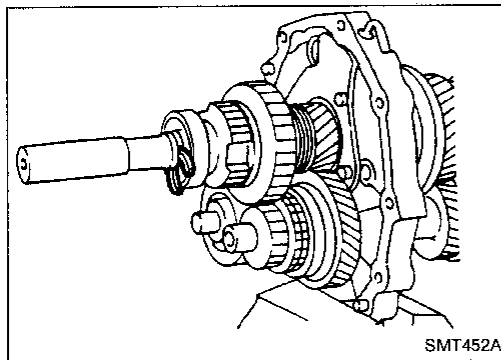

- n. Select proper mainshaft C-ring to minimize clearance of groove.

Allowable clearance of groove:

0 - 0.1 mm (0 - 0.004 in)

Mainshaft C-ring:

Refer to SDS, MT-60.

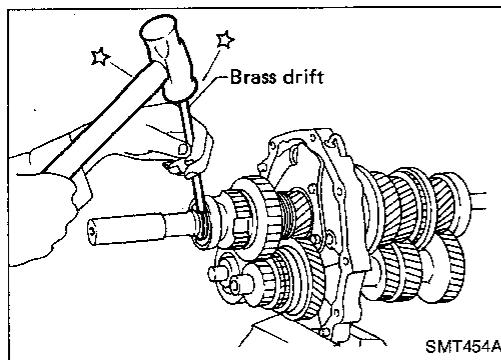

- o. Install selected C-ring, C-ring holder and mainshaft rear snap ring.

Gear Components (Cont'd)

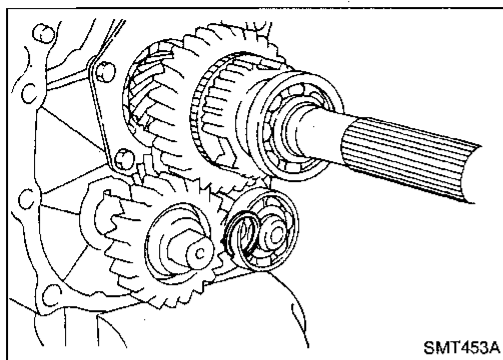

- p. Install spacer and then select proper counter gear rear snap ring to minimize clearance of groove.

Allowable clearance of groove:

0 - 0.1 mm (0 - 0.004 in)

Counter gear rear snap ring:

Refer to SDS, MT-60.

- q. Install selected counter gear rear snap ring.

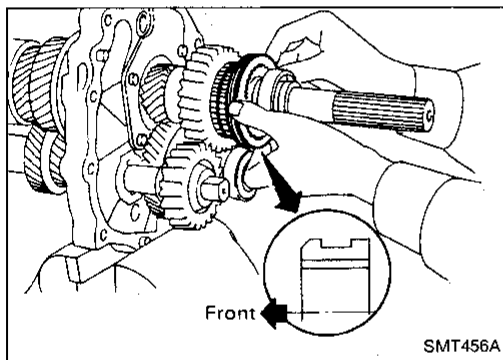
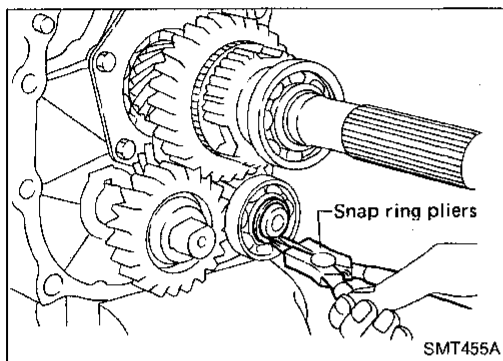

- r. Install reverse coupling sleeve.

Pay attention to its direction.

- s. Measure each gear end play as a final check — Refer to "DISASSEMBLY", MT-39.

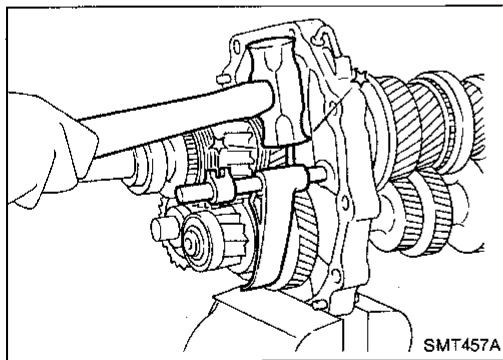

Shift Control Components

1. Install OD fork rod and OD shift fork. Then install retaining pin into OD shift fork.
2. Install 1st & 2nd, 3rd & 4th and reverse shift fork onto coupling sleeve.

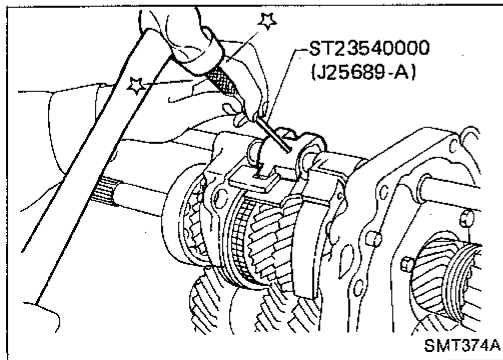

3. Install striking rod into hole of shift forks, striking lever and interlock and then install retaining pin into striking lever.

Make sure that striking rod moves smoothly.

GI

MA

EM

LC

EF & EC

FE

CL

MT

AT

TF

PD

FA

RA

BR

ST

BF

HA

EL

IDX

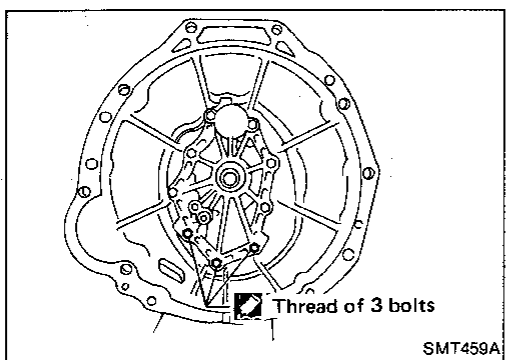
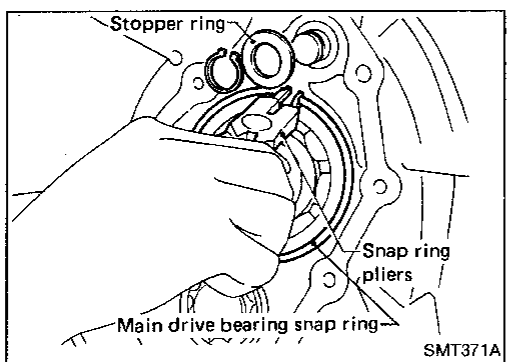
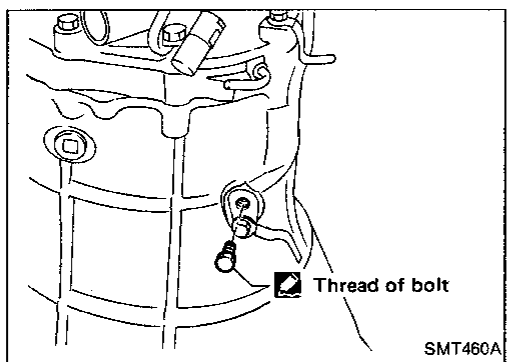
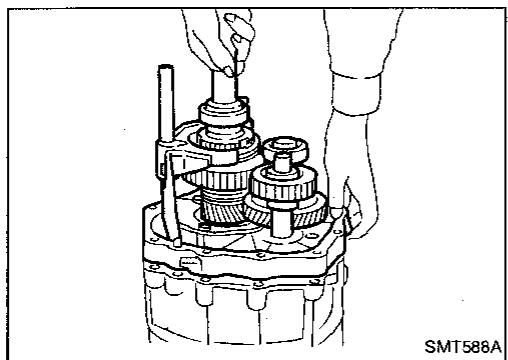
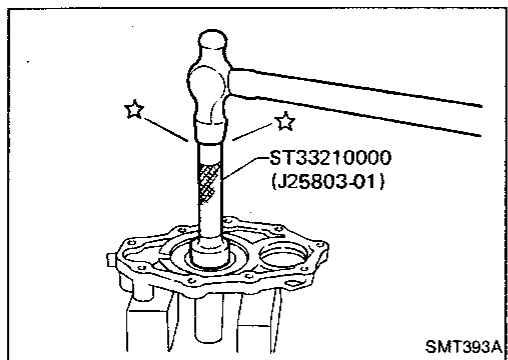

Case Components

1. Install front cover oil seal.
Apply multi-purpose grease to seal lip.
2. Install selected counter gear front bearing shim onto transmission case.
Apply multi-purpose grease.
3. Apply sealant to mating surface of transmission case.
4. Install gear assembly onto transmission case.
5. Install check spring and check ball into interlock stopper.
Apply multi-purpose grease to check ball.
6. Install interlock stopper assembly and then tighten check ball plug.
Apply sealant to thread of check ball plug.
7. Install stopper ring and main drive bearing snap ring.
8. Install front cover and gasket.
Apply sealant to thread of 3 bolts shown left.
9. Apply sealant to mating surface of adapter plate.

Case Components (Cont'd)

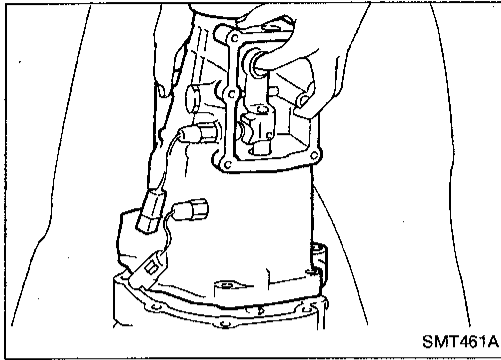

10. Install rear extension (or OD gear case) together with striking arm.

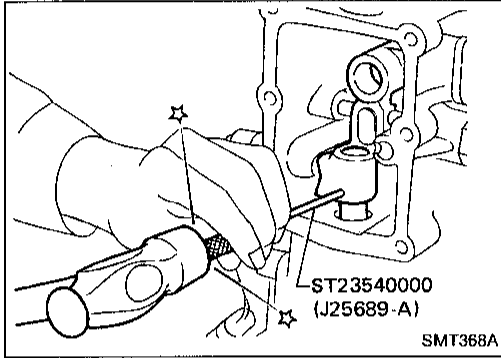

11. Install retaining pin into striking arm.

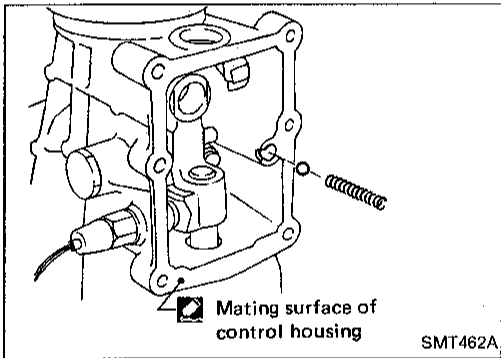

12. Install return spring and check ball and then install control housing.

Apply sealant to mating surface of rear extension (or OD gear case).

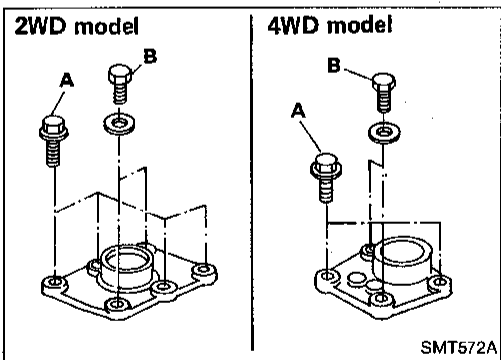

13. Tighten control housing bolts.

Bolt head size:

A bolts 12 mm (0.47 in)

B bolts 13 mm (0.51 in)

GI

MA

EM

LC

EF &
EC

FE

CL

MT

AT

TF

PD

FA

RA

BR

ST

BF

HA

EL

IDX

General Specifications

Applied model	KA24E		VG30E		
	2WD	4WD	2WD		4WD
			Truck	Wagon	
Transmission	FS5W71C		FS5R30A		
Number of speed	5				
Shift pattern					
Synchromesh type	Warner				
Gear ratio					
1st	3.321	3.985	3.580		4.061
2nd	1.902	2.246	2.077		2.357
3rd	1.308	1.415	1.360		1.490
4th	1.000	1.000	1.000		1.000
OD	0.838	0.821	0.811		0.862
Reverse	3.382	3.657	3.636		4.125
Number of teeth					
Mainshaft					
Drive	22	21	22		20
1st	33	34	32		32
2nd	27	28	30		30
3rd	26	26	29		28
OD	22	21	24		23
Reverse	36	36	30		30
Countershaft					
Drive	31	32	32		33
1st	14	13	13		13
2nd	20	19	21		21
3rd	28	28	31		31
OD	37	39	43		44
Reverse	15	15	12		12
Reverse idler gear	21	21	22		22
Oil capacity ℓ (US pt, Imp pt)	2.0 (4-1/4, 3-1/2)	4.0 (8-1/2, 7)	2.4 (5-1/8, 4-1/4)		3.6 (7-5/8, 6-3/8)
Remarks	Mainshaft braking mechanism	Reverse synchronizer	2nd & 3rd double baulk ring type synchronizer		
	2nd double baulk ring type synchronizer				

Inspection and Adjustment

GEAR END PLAY

Unit: mm (in)

1st gear	0.31 - 0.41 (0.0122 - 0.0161)
2nd gear	0.11 - 0.21 (0.0043 - 0.0083)
3rd gear	0.11 - 0.21 (0.0043 - 0.0083)
OD gear	0.24 - 0.41 (0.0094 - 0.0161)

CLEARANCE BETWEEN BAULK RING AND GEAR

Unit: mm (in)

Standard	
1st	1.20 - 1.60 (0.0472 - 0.0630)
3rd & main drive	1.20 - 1.60 (0.0472 - 0.0630)
OD	1.20 - 1.60 (0.0472 - 0.0630)
Reverse (4WD)	1.10 - 1.55 (0.0433 - 0.0610)
Wear limit	
1st	0.80 (0.0315)
3rd & main drive	0.80 (0.0315)
OD	0.80 (0.0315)
Reverse (4WD)	0.70 (0.0276)

2nd baulk ring

Unit: mm (in)

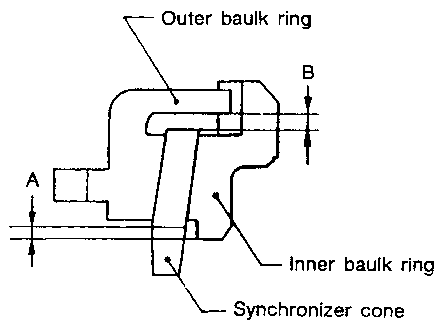

SMT044B

Dimension	Standard	Wear limit
A	0.6 - 1.1 (0.024 - 0.043)	0.2 (0.008)
B	0.7 - 0.9 (0.028 - 0.035)	

AVAILABLE SNAP RINGS

Main drive gear bearing

Allowable clearance		0 - 0.13 mm (0 - 0.0051 in)
Thickness mm (in)	Part number	
1.73 (0.0681)	32204-78005	
1.80 (0.0709)	32204-78000	
1.87 (0.0736)	32204-78001	
1.94 (0.0764)	32204-78002	
2.01 (0.0791)	32204-78003	
2.08 (0.0819)	32204-78004	

Mainshaft front

Allowable clearance		0 - 0.18 mm (0 - 0.0071 in)
Thickness mm (in)	Part number	
2.4 (0.094)	32263-V5200	
2.5 (0.098)	32263-V5201	
2.6 (0.102)	32263-V5202	

Mainshaft rear end bearing
(2WD model)

Allowable clearance		0 - 0.14 mm (0 - 0.0055 in)
Thickness mm (in)	Part number	
1.1 (0.043)	32228-20100	
1.2 (0.047)	32228-20101	
1.3 (0.051)	32228-20102	
1.4 (0.055)	32228-20103	

Counter drive gear

Allowable clearance		0 - 0.18 mm (0 - 0.0071 in)
Thickness mm (in)	Part number	
1.4 (0.055)	32215-E9000	
1.5 (0.059)	32215-E9001	
1.6 (0.063)	32215-E9002	

GI
MA
EM
LC
EF & EC
FE
CL
MT
AT
TF
PD
FA
RA
BR
ST
BF
HA
EL
IDX

Inspection and Adjustment (Cont'd)

AVAILABLE SHIMS

Counter front bearing

Unit: mm (in)

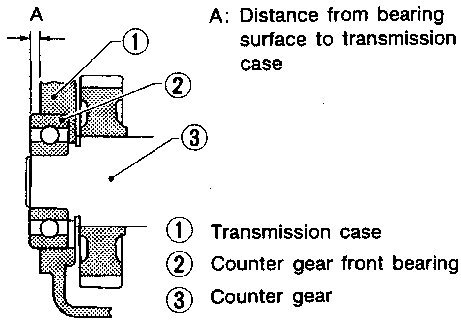

TM371

"A"	Thickness of shim	Part number
4.52 - 4.71 (0.1780 - 0.1854)	Not necessary	
4.42 - 4.51 (0.1740 - 0.1776)	0.1 (0.004)	32218-V5000
4.32 - 4.41 (0.1701 - 0.1736)	0.2 (0.008)	32218-V5001
4.22 - 4.31 (0.1661 - 0.1697)	0.3 (0.012)	32218-V5002
4.12 - 4.21 (0.1622 - 0.1657)	0.4 (0.016)	32218-V5003
4.02 - 4.11 (0.1583 - 0.1618)	0.5 (0.020)	32218-V5004
3.92 - 4.01 (0.1543 - 0.1579)	0.6 (0.024)	32218-V5005

Inspection and Adjustment

GEAR END PLAY

Gear	End play mm (in)
1st main gear	0.23 - 0.33 (0.0091 - 0.0130)
2nd main gear	0.23 - 0.33 (0.0091 - 0.0130)
3rd main gear	0.23 - 0.33 (0.0091 - 0.0130)
OD counter gear	0.23 - 0.33 (0.0091 - 0.0130)
Reverse main gear	0.33 - 0.43 (0.0130 - 0.0169)
Counter gear	0.10 - 0.25 (0.0039 - 0.0098)
Reverse idler gear	0.30 - 0.53 (0.0118 - 0.0209)

CLEARANCE BETWEEN BAULK RING AND GEAR

Unit: mm (in)

	Standard	Wear limit
1st	1.05 - 1.3 (0.0413 - 0.0512)	0.7 (0.028)
Main drive	1.05 - 1.3 (0.0413 - 0.0512)	0.7 (0.028)
OD	1.05 - 1.3 (0.0413 - 0.0512)	0.7 (0.028)

2nd and 3rd baulk ring

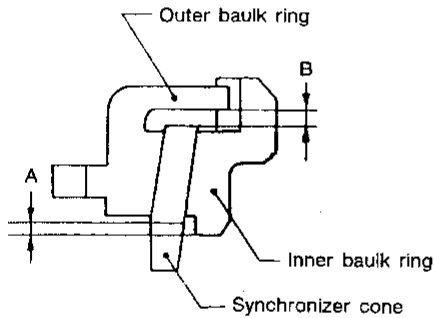

SMT044B

Unit: mm (in)

Dimension	Standard	Wear limit
A	0.6 - 1.1 (0.024 - 0.043)	0.2 (0.008)
B	0.7 - 0.9 (0.028 - 0.035)	0.2 (0.008)

DISTANCE BETWEEN REAR SURFACE OF REVERSE CONE AND REVERSE BAULK RING

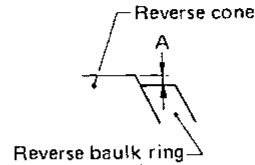

Unit: mm (in)

	Standard	Wear limit
Dimension "A"	-0.1 to 0.35 (-0.0039 to 0.0138)	0.7 (0.028)

AVAILABLE SNAP RING

Main drive gear snap ring

Allowable clearance		0 - 0.1 mm (0 - 0.004 in)
Thickness mm (in)	Part number	
1.89 (0.0744)	32204-01G60	
1.95 (0.0768)	32204-01G61	
1.99 (0.0783)	32204-01G62	
2.03 (0.0799)	32204-01G63	
2.07 (0.0815)	32204-01G64	
2.11 (0.0831)	32204-01G65	
2.15 (0.0846)	32204-01G66	
2.19 (0.0862)	32204-01G67	

Mainshaft front snap ring

Allowable clearance		0 - 0.1 mm (0 - 0.004 in)
Thickness mm (in)	Part number	
1.89 (0.0744)	32204-01G60	
1.95 (0.0768)	32204-01G61	
1.99 (0.0783)	32204-01G62	
2.03 (0.0799)	32204-01G63	
2.07 (0.0815)	32204-01G64	
2.11 (0.0831)	32204-01G65	
2.15 (0.0846)	32204-01G66	
2.19 (0.0862)	32204-01G67	

GI
MA
EM
LC
EF & EC
FE
CL
MT
AT
TF
PD
FA
RA
BR
ST
BF
HA
EL
IDX

Inspection and Adjustment (Cont'd)

Counter gear rear snap ring

Allowable clearance		0 - 0.1 mm (0 - 0.004 in)
Thickness mm (in)	Part number	
1.26 (0.0496)	32236-01G08	
1.32 (0.0520)	32236-01G00	
1.38 (0.0543)	32236-01G01	
1.44 (0.0567)	32236-01G02	
1.50 (0.0591)	32236-01G03	
1.56 (0.0614)	32236-01G04	
1.62 (0.0638)	32236-01G05	
1.68 (0.0661)	32236-01G06	
1.74 (0.0685)	32236-01G07	

AVAILABLE C-RING

Mainshaft C-ring

Allowable clearance		0 - 0.1 mm (0 - 0.004 in)
Thickness mm (in)	Part number	
2.63 (0.1035)	32348-01G15	
2.70 (0.1063)	32348-01G00	
2.77 (0.1091)	32348-01G01	
2.84 (0.1118)	32348-01G02	
2.91 (0.1146)	32348-01G03	
2.98 (0.1173)	32348-01G04	
3.05 (0.1201)	32348-01G05	
3.12 (0.1228)	32348-01G06	
3.19 (0.1256)	32348-01G07	
3.26 (0.1283)	32348-01G08	
3.33 (0.1311)	32348-01G09	
3.40 (0.1339)	32348-01G10	
3.47 (0.1366)	32348-01G11	
3.54 (0.1394)	32348-01G12	
3.61 (0.1421)	32348-01G13	
3.68 (0.1449)	32348-01G14	

AVAILABLE SHIM AND WASHER

Table for selecting proper counter gear front bearing thrust washer

Dial indicator deflection mm (in)	Thickness of proper washer mm (in)	Part number
0.93 - 1.02 (0.0366 - 0.0402)	0.88 (0.0346)	32218-01G11
1.03 - 1.12 (0.0406 - 0.0441)	0.96 (0.0378)	32218-01G12
1.13 - 1.22 (0.0445 - 0.0480)	1.04 (0.0409)	32218-01G13
1.23 - 1.32 (0.0484 - 0.0520)	1.12 (0.0441)	32218-01G14
1.33 - 1.42 (0.0524 - 0.0559)	1.28 (0.0504)	32218-01G15
1.43 - 1.52 (0.0563 - 0.0598)	1.36 (0.0535)	32218-01G16
1.53 - 1.62 (0.0602 - 0.0638)	1.44 (0.0567)	32218-01G17

Reverse idler rear thrust washer

Thickness mm (in)	Part number
1.97 (0.0776)	32284-01G10
2.07 (0.0815)	32284-01G11