

SECTION **EXT**
EXTERIOR

A
B
C
D
E
F
G
H
I
J
L
M
N
O
P

CONTENTS

SYMPTOM DIAGNOSIS	3	FENDER PROTECTOR	23
SQUEAK AND RATTLE TROUBLE DIAG- NOSES	3	FENDER PROTECTOR	23
Work Flow	3	FENDER PROTECTOR : Exploded View	23
Inspection Procedure	5	FENDER PROTECTOR : Removal and Installa- tion	23
Diagnostic Worksheet	7	REAR WHEEL HOUSE PROTECTOR	23
PRECAUTION	9	REAR WHEEL HOUSE PROTECTOR : Exploded View	24
PRECAUTIONS	9	REAR WHEEL HOUSE PROTECTOR : Removal and Installation	24
Precaution for Supplemental Restraint System (SRS) "AIR BAG" and "SEAT BELT PRE-TEN- SIONER"	9	MUDGUARD	25
Precaution Necessary for Steering Wheel Rota- tion after Battery Disconnect	9	Exploded View	25
Precaution for Procedure without Cowl Top Cover... 10	10	Removal and Installation	25
Precaution for Work	10	FLOOR SIDE FAIRING	26
PREPARATION	11	Exploded View	26
PREPARATION	11	Removal and Installation	26
Special Service Tools	11	ROOF RAIL	28
Commercial Service Tools	11	Exploded View	28
ON-VEHICLE REPAIR	12	Removal and Installation	28
FRONT BUMPER	12	ROOF SIDE MOLDING	30
Exploded View	12	NORMAL ROOF	30
Removal and Installation	13	NORMAL ROOF : Exploded View	30
REAR BUMPER	15	NORMAL ROOF : Removal and Installation	30
Exploded View	15	SUNROOF	31
Removal and Installation	15	SUNROOF : Exploded View	31
FRONT GRILLE	18	SUNROOF : Removal and Installation	31
Exploded View	18	DOOR OUTSIDE MOLDING	33
Removal and Installation	18	Exploded View	33
COWL TOP	20	Removal and Installation	33
Exploded View	20	DOOR OUTSIDE LOWER MOLDING	35
Removal and Installation	20	Exploded View	35
		Removal and Installation	35

EXT

DOOR PARTING SEAL	37	DOOR SASH COVER	39
Exploded View	37	Exploded View	39
Removal and Installation	37	Removal and Installation	39

SQUEAK AND RATTLE TROUBLE DIAGNOSES

< SYMPTOM DIAGNOSIS >

SYMPTOM DIAGNOSIS

SQUEAK AND RATTLE TROUBLE DIAGNOSES

Work Flow

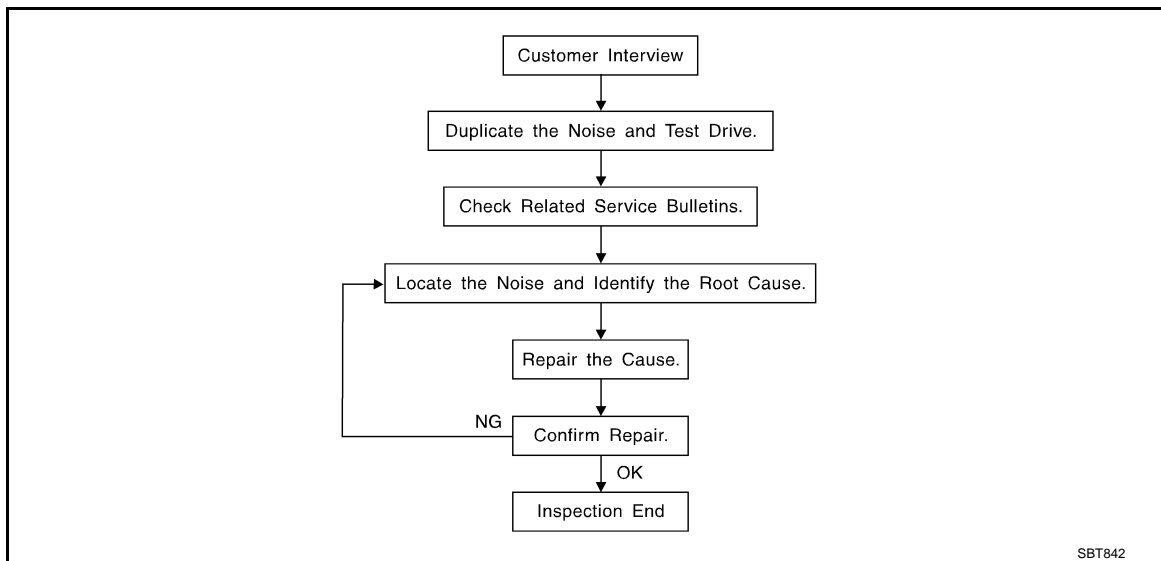

CUSTOMER INTERVIEW

Interview the customer if possible, to determine the conditions that exist when the noise occurs. Use the Diagnostic Worksheet during the interview to document the facts and conditions when the noise occurs and any of customer's comments; refer to [EXT-7, "Diagnostic Worksheet"](#). This information is necessary to duplicate the conditions that exist when the noise occurs.

- The customer may not be able to provide a detailed description or the location of the noise. Attempt to obtain all the facts and conditions that exist when the noise occurs (or does not occur).
- If there is more than one noise in the vehicle, perform a diagnosis and repair the noise that the customer is concerned about. This can be accomplished by performing a cruise test on the vehicle with the customer.
- After identifying the type of noise, isolate the noise in terms of its characteristics. The noise characteristics are provided so the customer, service adviser and technician are all speaking the same language when defining the noise.
- Squeak – (Like tennis shoes on a clean floor)
Squeak characteristics include the light contact/fast movement/brought on by road conditions/hard surfaces = higher pitch noise/softer surfaces = lower pitch noises/edge to surface = chirping
- Creak – (Like walking on an old wooden floor)
Creak characteristics include firm contact/slow movement/twisting with a rotational movement/pitch dependent on materials/often brought on by activity.
- Rattle – (Like shaking a baby rattle)
Rattle characteristics include the fast repeated contact/vibration or similar movement/loose parts/missing clip or fastener/incorrect clearance.
- Knock – (Like a knock on a door)
Knock characteristics include hollow sounding/sometimes repeating/often brought on by driver action.
- Tick – (Like a clock second hand)
Tick characteristics include gentle contacting of light materials/loose components/can be caused by driver action or road conditions.
- Thump – (Heavy, muffled knock noise)
Thump characteristics include softer knock/dead sound often brought on by activity.
- Buzz – (Like a bumblebee)
Buzz characteristics include high frequency rattle/firm contact.
- Often the degree of acceptable noise level will vary depending up on the person. A noise that a technician may judge as acceptable may be very irritating to the customer.
- Weather conditions, especially humidity and temperature, may have a great effect on noise level.

DUPLICATE THE NOISE AND TEST DRIVE

SQUEAK AND RATTLE TROUBLE DIAGNOSES

< SYMPTOM DIAGNOSIS >

If possible, drive the vehicle with the customer until the noise is duplicated. Note any additional information on the Diagnostic Worksheet regarding the conditions or location of the noise. This information can be used to duplicate the same conditions when the repair is reconfirmed.

If the noise can be duplicated easily during the test drive, to help identify the source of the noise, try to duplicate the noise with the vehicle stopped by doing one or all of the following:

- 1) Close a door.
 - 2) Tap or push/pull around the area where the noise appears to be coming from.
 - 3) Rev the engine.
 - 4) Use a floor jack to recreate vehicle "twist".
 - 5) At idle, apply engine load (electrical load, half-clutch on M/T models, drive position on A/T models).
 - 6) Raise the vehicle on a hoist and hit a tire with a rubber hammer.
- Drive the vehicle and attempt to duplicate the conditions the customer states exist when the noise occurs.
 - If it is difficult to duplicate the noise, drive the vehicle slowly on an undulating or rough road to stress the vehicle body.

CHECK RELATED SERVICE BULLETINS

After verifying the customer concern or symptom, check ASIST for Technical Service Bulletins (TSBs) related to that concern or symptom.

If a TSB relates to the symptom, follow the procedure to repair the noise.

LOCATE THE NOISE AND IDENTIFY THE ROOT CAUSE

1. Narrow down the noise to a general area. To help pinpoint the source of the noise, use a listening tool (Chassis ear: J-39570, Engine ear and mechanics stethoscope).
2. Narrow down the noise to a more specific area and identify the cause of the noise by:
 - Removing the components in the area that is are suspected to be the cause of the noise.
Do not use too much force when removing clips and fasteners, otherwise clips and fastener can be broken or lost during the repair, resulting in the creation of new noise.
 - Tapping or pushing/pulling the component that is are suspected to be the cause of the noise.
Do not tap or push/pull the component with excessive force, otherwise the noise will be eliminated only temporarily.
 - Feeling for a vibration by hand by touching the component(s) that is are suspected to be the cause of the noise.
 - Placing a piece of paper between components that are suspected to be the cause of the noise.
 - Looking for loose components and contact marks.
Refer to [EXT-5. "Inspection Procedure"](#).

REPAIR THE CAUSE

- If the cause is a loose component, tighten the component securely.
- If the cause is insufficient clearance between components:
 - Separate components by repositioning or loosening and retightening the component, if possible.
 - Insulate components with a suitable insulator such as urethane pads, foam blocks, felt cloth tape or urethane tape. A Nissan Squeak and Rattle Kit (J-43980) is available through the authorized Nissan Parts Department.

CAUTION:

Never use excessive force as many components are constructed of plastic and may be damaged.

NOTE:

Always check with the Parts Department for the latest parts information.

The following materials are contained in the Nissan Squeak and Rattle Kit (J-43980). Each item can be ordered separately as needed.

URETHANE PADS [1.5 mm (0.059 in) thick]

Insulates connectors, harness, etc.

76268-9E005: 100 × 135 mm (3.94 × 5.31 in)/76884-71L01: 60 × 85 mm (2.36 × 3.35 in)/76884-71L02: 15 × 25 mm (0.59 × 0.98 in)

INSULATOR (Foam blocks)

Insulates components from contact. Can be used to fill space behind a panel.

73982-9E000: 45 mm (1.77 in) thick, 50 × 50 mm (1.97 × 1.97 in)/73982-

50Y00: 10 mm (0.39 in) thick, 50 × 50 mm (1.97 × 1.97 in)

INSULATOR (Light foam block)

80845-71L00: 30 mm (1.18 in) thick, 30 × 50 mm (1.18 × 1.97in)

FELT CLOTHTAPE

Used to insulate where movement does not occur. Ideal for instrument panel applications.

SQUEAK AND RATTLE TROUBLE DIAGNOSES

< SYMPTOM DIAGNOSIS >

68370-4B000: 15 × 25 mm (0.59 × 0.98 in) pad/68239-13E00: 5 mm (0.20 in) wide tape roll

The following materials, not found in the kit, can also be used to repair squeaks and rattles.

UHMW (TEFLON) TAPE

Insulates where slight movement is present. Ideal for instrument panel applications.

SILICONE GREASE

Used in place of UHMW tape that is be visible or does not fit. Will only last a few months.

SILICONE SPRAY

Used when grease cannot be applied.

DUCT TAPE

Used to eliminate movement.

CONFIRM THE REPAIR

Confirm that the cause of a noise is repaired by test driving the vehicle. Operate the vehicle under the same conditions as when the noise originally occurred. Refer to the notes on the Diagnostic Worksheet.

Inspection Procedure

INFOID:000000004778627

Refer to Table of Contents for specific component removal and installation information.

INSTRUMENT PANEL

Most incidents are caused by contact and movement between:

1. The cluster lid A and instrument panel
2. Acrylic lens and combination meter housing
3. Instrument panel to front pillar garnish
4. Instrument panel to windshield
5. Instrument panel mounting pins
6. Wiring harnesses behind the combination meter
7. A/C defroster duct and duct joint

These incidents can usually be located by tapping or moving the components to duplicate the noise or by pressing on the components while driving to stop the noise. Most of these incidents can be repaired by applying felt cloth tape or silicon spray (in hard to reach areas). Urethane pads can be used to insulate wiring harness.

CAUTION:

Never use silicone spray to isolate a squeak or rattle. If the area is saturated with silicone, the recheck of repair becomes impossible.

CENTER CONSOLE

Components to pay attention to include:

1. Shifter assembly cover to finisher
2. A/C control unit and cluster lid C
3. Wiring harnesses behind audio and A/C control unit

The instrument panel repair and isolation procedures also apply to the center console.

DOORS

Pay attention to the following:

1. Finisher and inner panel making a slapping noise
2. Inside handle escutcheon to door finisher
3. Wiring harnesses tapping
4. Door striker out of alignment causing a popping noise on starts and stops

Tapping or moving the components or pressing on them while driving to duplicate the conditions can isolate many of these incidents. The areas can usually be insulated with felt cloth tape or insulator foam blocks from the Nissan Squeak and Rattle Kit (J-43980) to repair the noise.

TRUNK

Trunk noises are often caused by a loose jack or loose items put into the trunk by the customer.

In addition look for the following:

1. Trunk lid dumpers out of adjustment
2. Trunk lid striker out of adjustment

A

B

C

D

E

F

G

H

I

J

EXT

L

M

N

O

P

SQUEAK AND RATTLE TROUBLE DIAGNOSES

< SYMPTOM DIAGNOSIS >

3. The trunk lid torsion bars knocking together
4. A loose license plate or bracket

Most of these incidents can be repaired by adjusting, securing or insulating the item(s) or component(s) causing the noise.

SUNROOF/HEADLINING

Noises in the sunroof/headlining area can often be traced to one of the following:

1. Sunroof lid, rail, linkage or seals making a rattle or light knocking noise
2. Sunvisor shaft shaking in the holder
3. Front or rear windshield touching headlining and squeaking

Again, pressing on the components to stop the noise while duplicating the conditions can isolate most of these incidents. Repairs usually consist of insulating with felt cloth tape.

SEATS

When isolating seat noise it's important to note the position the seats in and the load placed on the seat when the noise occurs. These conditions should be duplicated when verifying and isolating the cause of the noise.

Cause of seat noise include:

1. Headrest rods and holder
2. A squeak between the seat pad cushion and frame
3. The rear seatback lock and bracket

These noises can be isolated by moving or pressing on the suspected components while duplicating the conditions under which the noise occurs. Most of these incidents can be repaired by repositioning the component or applying urethane tape to the contact area.

UNDERHOOD

Some interior noise may be caused by components under the hood or on the engine wall. The noise is then transmitted into the passenger compartment.

Causes of transmitted underhood noise include:

1. Any component mounted to the engine wall
2. Components that pass through the engine wall
3. Engine wall mounts and connectors
4. Loose radiator mounting pins
5. Hood bumpers out of adjustment
6. Hood striker out of adjustment

These noises can be difficult to isolate since they cannot be reached from the interior of the vehicle. The best method is to secure, move or insulate one component at a time and test drive the vehicle. Also, engine RPM or load can be changed to isolate the noise. Repairs can usually be made by moving, adjusting, securing, or insulating the component causing the noise.

SQUEAK AND RATTLE TROUBLE DIAGNOSES

< SYMPTOM DIAGNOSIS >

Diagnostic Worksheet

INFOID:000000004778628



SQUEAK & RATTLE DIAGNOSTIC WORKSHEET

Dear Nissan Customer:

We are concerned about your satisfaction with your Nissan vehicle. Repairing a squeak or rattle sometimes can be very difficult. To help us fix your Nissan right the first time, please take a moment to note the area of the vehicle where the squeak or rattle occurs and under what conditions. You may be asked to take a test drive with a service advisor or technician to ensure we confirm the noise you are hearing.

I. WHERE DOES THE NOISE COME FROM? (circle the area of the vehicle)

The illustrations are for reference only, and may not reflect the actual configuration of your vehicle.

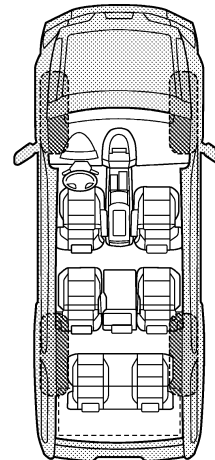
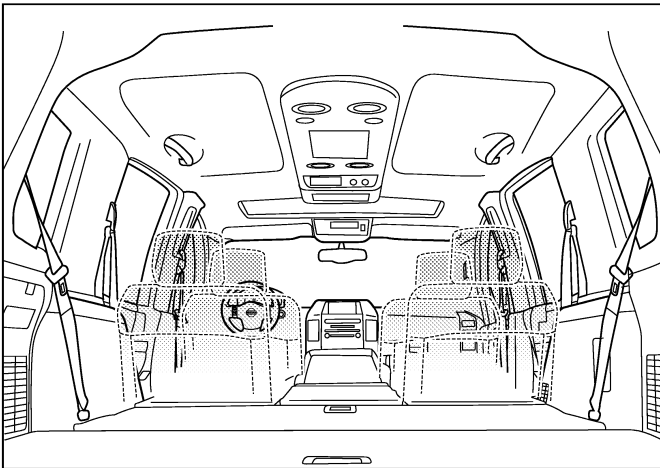
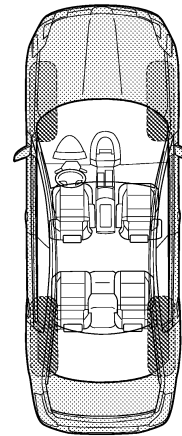
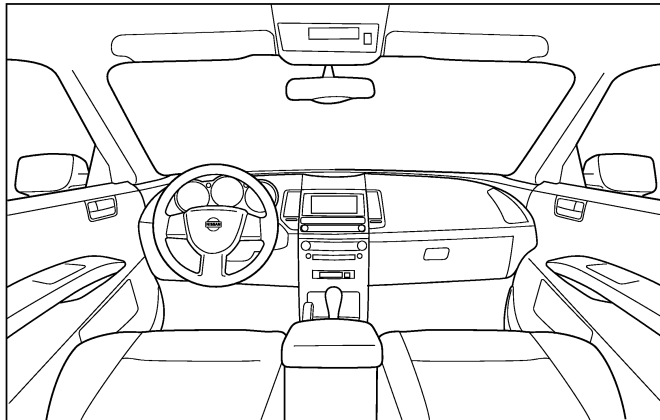

Continue to page 2 of the worksheet and briefly describe the location of the noise or rattle. In addition, please indicate the conditions which are present when the noise occurs.

PIIB8740E

A
B
C
D
E
F
G
H
I
J
EXT
L
M
N
O
P

SQUEAK AND RATTLE TROUBLE DIAGNOSES

< SYMPTOM DIAGNOSIS >

SQUEAK & RATTLE DIAGNOSTIC WORKSHEET - page 2

Briefly describe the location where the noise occurs:

II. WHEN DOES IT OCCUR? (please check the boxes that apply)

- | | |
|---|--|
| <input type="checkbox"/> anytime | <input type="checkbox"/> after sitting out in the rain |
| <input type="checkbox"/> 1st time in the morning | <input type="checkbox"/> when it is raining or wet |
| <input type="checkbox"/> only when it is cold outside | <input type="checkbox"/> dry or dusty conditions |
| <input type="checkbox"/> only when it is hot outside | <input type="checkbox"/> other: |

III. WHEN DRIVING:

- through driveways
- over rough roads
- over speed bumps
- only about ____ mph
- on acceleration
- coming to a stop
- on turns: left, right or either (circle)
- with passengers or cargo
- other: _____
- after driving ____ miles or ____ minutes

IV. WHAT TYPE OF NOISE

- squeak (like tennis shoes on a clean floor)
- creak (like walking on an old wooden floor)
- rattle (like shaking a baby rattle)
- knock (like a knock at the door)
- tick (like a clock second hand)
- thump (heavy, muffled knock noise)
- buzz (like a bumble bee)

TO BE COMPLETED BY DEALERSHIP PERSONNEL

Test Drive Notes:

	YES	NO	Initials of person performing
Vehicle test driven with customer	<input type="checkbox"/>	<input type="checkbox"/>	_____
- Noise verified on test drive	<input type="checkbox"/>	<input type="checkbox"/>	_____
- Noise source located and repaired	<input type="checkbox"/>	<input type="checkbox"/>	_____
- Follow up test drive performed to confirm repair	<input type="checkbox"/>	<input type="checkbox"/>	_____

VIN: _____ Customer Name: _____
W.O.# _____ Date: _____

This form must be attached to Work Order

PIIB8742E

PRECAUTIONS

< PRECAUTION >

PRECAUTION

PRECAUTIONS

Precaution for Supplemental Restraint System (SRS) "AIR BAG" and "SEAT BELT PRE-TENSIONER"

INFOID:000000004778855

The Supplemental Restraint System such as "AIR BAG" and "SEAT BELT PRE-TENSIONER", used along with a front seat belt, helps to reduce the risk or severity of injury to the driver and front passenger for certain types of collision. This system includes seat belt switch inputs and dual stage front air bag modules. The SRS system uses the seat belt switches to determine the front air bag deployment, and may only deploy one front air bag, depending on the severity of a collision and whether the front occupants are belted or unbelted. Information necessary to service the system safely is included in the "SRS AIRBAG" and "SEAT BELT" of this Service Manual.

WARNING:

- To avoid rendering the SRS inoperative, which could increase the risk of personal injury or death in the event of a collision which would result in air bag inflation, all maintenance must be performed by an authorized NISSAN/INFINITI dealer.
- Improper maintenance, including incorrect removal and installation of the SRS, can lead to personal injury caused by unintentional activation of the system. For removal of Spiral Cable and Air Bag Module, see the "SRS AIRBAG".
- Never use electrical test equipment on any circuit related to the SRS unless instructed to in this Service Manual. SRS wiring harnesses can be identified by yellow and/or orange harnesses or harness connectors.

PRECAUTIONS WHEN USING POWER TOOLS (AIR OR ELECTRIC) AND HAMMERS

When working near the Airbag Diagnosis Sensor Unit or other Airbag System sensors while ignition switch is ON or engine is running, never use air or electric power tools or strike near the sensor(s) with a hammer. Heavy vibration may activate the sensor(s), deploy the airbag(s), possibly cause serious injury. When using air or electric power tools or hammers, always turn OFF ignition switch, disconnect the battery, and wait 3 minutes or more before performing any service.

Precaution Necessary for Steering Wheel Rotation after Battery Disconnect

INFOID:000000004778856

NOTE:

- Before removing and installing any control units, first turn the push-button ignition switch to the LOCK position, then disconnect both battery cables.
- After finishing work, confirm that all control unit connectors are connected properly, then re-connect both battery cables.
- Always use CONSULT-III to perform self-diagnosis as a part of each function inspection after finishing work. If a DTC is detected, perform trouble diagnosis according to self-diagnosis results.

This vehicle is equipped with a push-button ignition switch and a steering lock unit.

If the battery is disconnected or discharged, the steering wheel will lock and cannot be turned.

If turning the steering wheel is required with the battery disconnected or discharged, follow the procedure below before starting the repair operation.

OPERATION PROCEDURE

1. Connect both battery cables.

NOTE:

Supply power using jumper cables if battery is discharged.

2. Turn the push-button ignition switch to ACC position.
(At this time, the steering lock will be released.)
3. Disconnect both battery cables. The steering lock will remain released with both battery cables disconnected and the steering wheel can be turned.
4. Perform the necessary repair operation.
5. When the repair work is completed, re-connect both battery cables. With the brake pedal released, turn the push-button ignition switch from ACC position to ON position, then to LOCK position. (The steering wheel will lock when the push-button ignition switch is turned to LOCK position.)
6. Perform self-diagnosis check of all control units using CONSULT-III.

A

B

C

D

E

F

G

H

I

J

EXT

L

M

N

O

P

PRECAUTIONS

< PRECAUTION >

Precaution for Procedure without Cowl Top Cover

INFOID:000000004354939

When performing the procedure after removing cowl top cover, cover the lower end of windshield with urethane, etc.

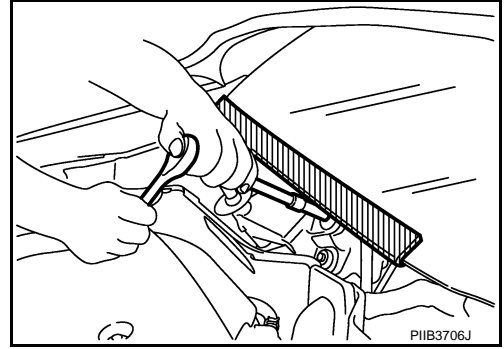

PIIB3706J

Precaution for Work

INFOID:000000003350492

- After removing and installing the opening/closing parts, be sure to carry out fitting adjustments to check their operation.
- Check the lubrication level, damage, and wear of each part. If necessary, grease or replace it.

PREPARATION

< PREPARATION >

PREPARATION

PREPARATION

Special Service Tools

INFOID:000000003350461

The actual shapes of Kent-Moore tools may differ from those of special service tools illustrated here.

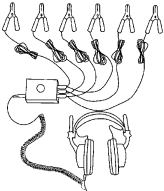
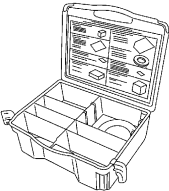
	Tool number (Kent-Moore No.) Tool name	Description
(J-39570) Chassis ear	 <p>SIIA0993E</p>	Locates the noise
(J-43980) NISSAN Squeak and Rattle Kit	 <p>SIIA0994E</p>	Repairs the cause of noise

Commercial Service Tools

INFOID:000000003350462

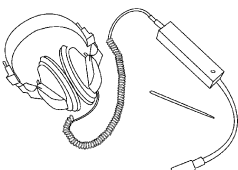
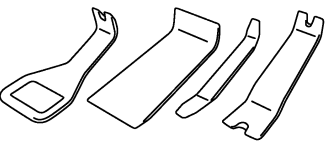
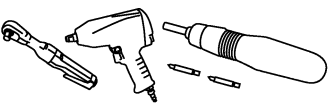
	Tool name	Description
Engine ear	 <p>SIIA0995E</p>	Locates the noise
Remover tool	 <p>PIIB7923J</p>	Removes clips, pawls and metal clips
Power tool	 <p>PIIB1407E</p>	

A

B

C

D

E

F

G

H

I

J

EXT

L

M

N

O

P

FRONT BUMPER

< ON-VEHICLE REPAIR >

ON-VEHICLE REPAIR

FRONT BUMPER

Exploded View

INFOID:000000003350463

SEC. 620

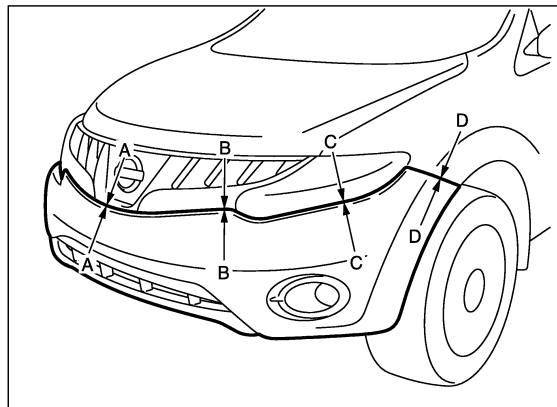
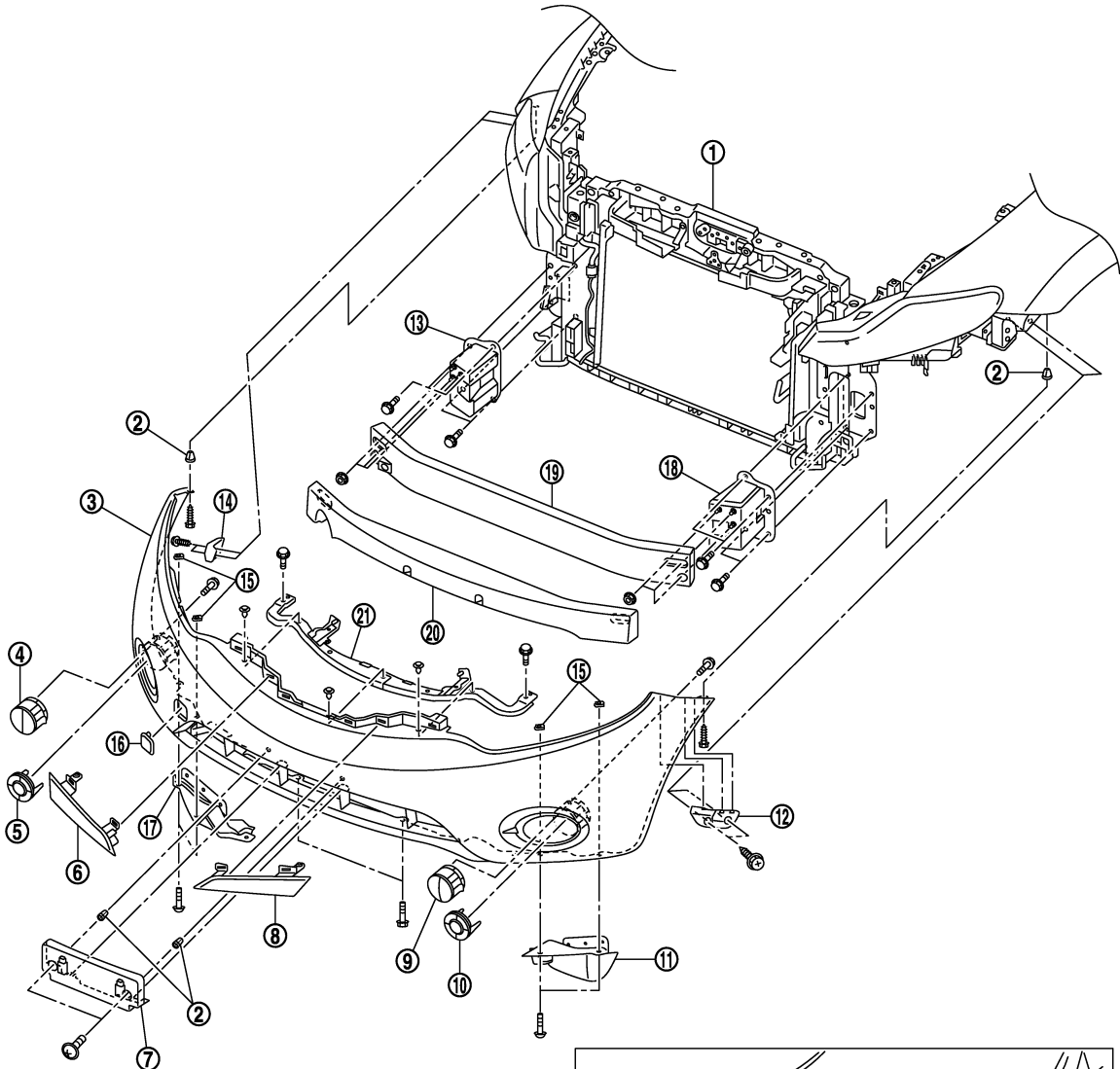

JMKIA1961ZZ

FRONT BUMPER

< ON-VEHICLE REPAIR >

- | | | |
|--------------------------|---------------------------------|---------------------------------|
| 1. Radiator core support | 2. Grommet | 3. Bumper fascia assembly |
| 4. Front fog lamp RH | 5. Bumper finisher RH | 6. Head lamp extension panel RH |
| 7. License plate bracket | 8. Head lamp extension panel LH | 9. Front fog lamp LH |
| 10. Bumper finisher LH | 11. Bumper lower finisher LH | 12. Bumper side bracket LH |
| 13. Bumper stay RH | 14. Bumper side bracket RH | 15. J nut |
| 16. Bumper lower molding | 17. Bumper lower finisher RH | 18. Bumper stay LH |
| 19. Bumper reinforcement | 20. Energy absorber | 21. Bumper retainer assembly |

Removal and Installation

INFOID:000000003350464

REMOVAL

CAUTION:

Bumper fascia is made of resin. Do not apply strong force to it, and be careful to prevent contact with oil.

1. Fully open hood assembly.
2. Remove front grille. Refer to [EXT-18, "Removal and Installation"](#).
3. Remove headlamp extension panel. Refer to [EXL-174, "Removal and Installation"](#).
4. Remove clips (A) of bumper fascia assembly (1) upper side.

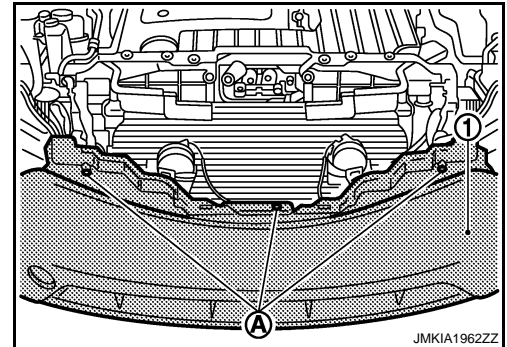

5. Remove fender protector fixing clips (A) (LH/RH).

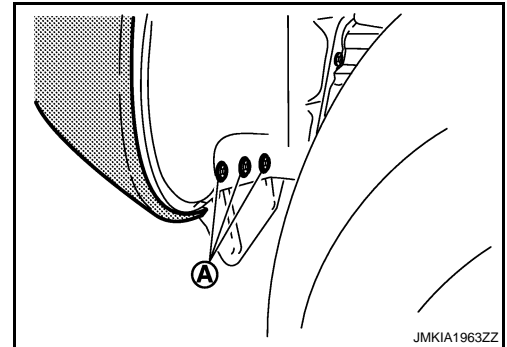

6. Remove front under cover and bumper lower finisher (LH/RH). Refer to [EXT-26, "Exploded View"](#).
7. Remove bumper fascia assembly fixing bolts (A).

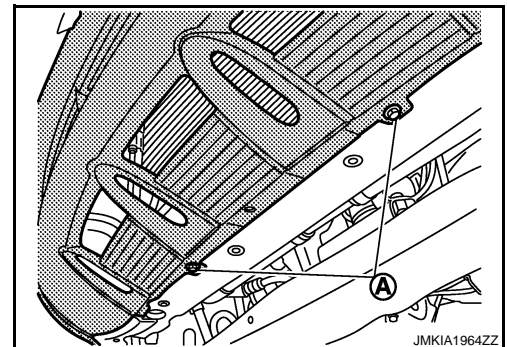

A
B
C
D
E
F
G
H
I
J
EXT
L
M
N
O
P

FRONT BUMPER

< ON-VEHICLE REPAIR >

8. Remove bumper fascia assembly fixing screws (A) (LH/RH).

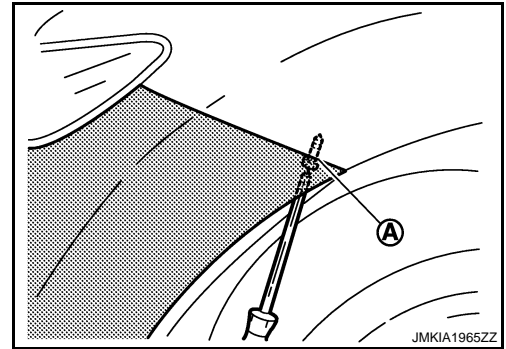

9. Disconnect front fog lamp harness connector (LH/RH).
 10. Pull the bumper fascia side toward the vehicle side to disengage the fitting of bumper side bracket and bumper fascia side.

 : Pawl

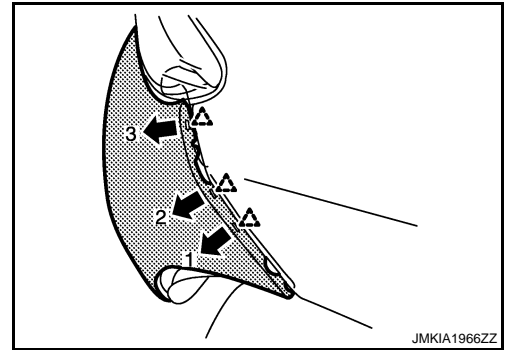

11. Remove bumper fascia assembly.
CAUTION:
When removing bumper fascia assembly, 2 workers are required so as to prevent it from dropping.
12. Remove the following parts after removing bumper fascia assembly.
- Front fog lamp assembly (LH/RH). Refer to [EXL-176. "Removal and Installation"](#).
 - Bumper side bracket (LH/RH)
 - License plate bracket
13. Remove energy absorber.
 14. Remove bumper reinforcement mounting nuts, and then remove bumper reinforcement.
 15. Remove bumper stay (LH/RH) mounting bolts, and then remove bumper stay (LH/RH).

INSTALLATION

Install in the reverse order of removal.

NOTE:

After installing, perform fitting adjustment.

Portion		Clearance
Front bumper – Front grille	A – A	0.2 – 2.8 mm (0.008 – 0.110 in)
Front bumper – Headlamp extension panel	B – B	0.2 – 2.8 mm (0.008 – 0.110 in)
Front bumper – Headlamp	C – C	0.3 – 2.7 mm (0.012 – 0.106 in)
Front bumper – Front fender	D – D	0.0 – 0.8 mm (0.000 – 0.031 in)

REAR BUMPER

< ON-VEHICLE REPAIR >

REAR BUMPER

Exploded View

INFOID:000000003350465

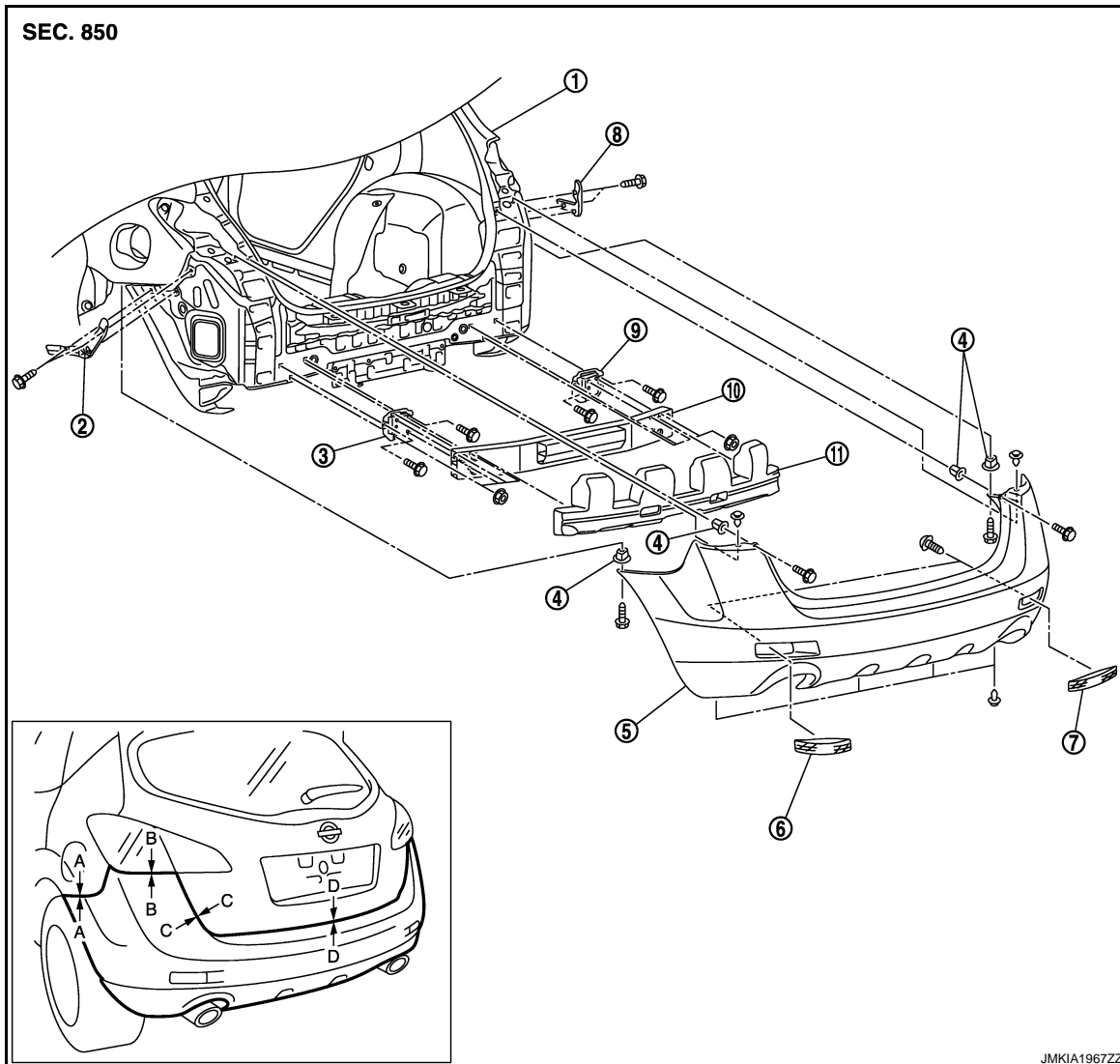

- | | | |
|--------------------------|---------------------------|------------------------|
| 1. Rear body complete | 2. Bumper side bracket LH | 3. Bumper stay LH |
| 4. Grommet | 5. Bumper fascia assembly | 6. Reflex reflector LH |
| 7. Reflex reflector RH | 8. Bumper side bracket RH | 9. Bumper stay RH |
| 10. Bumper reinforcement | 11. Energy absorber | |

Removal and Installation

INFOID:000000003350466

REMOVAL

CAUTION:

Bumper fascia is made of resin. Never apply strong force to it, and be careful to prevent contact with oil.

1. Fully open back door assembly.
2. Remove rear combination lamp (LH/RH).

REAR BUMPER

< ON-VEHICLE REPAIR >

3. Remove clips (A) located under rear combination lamp (LH/RH).
4. Remove screws (B) (LH/RH).

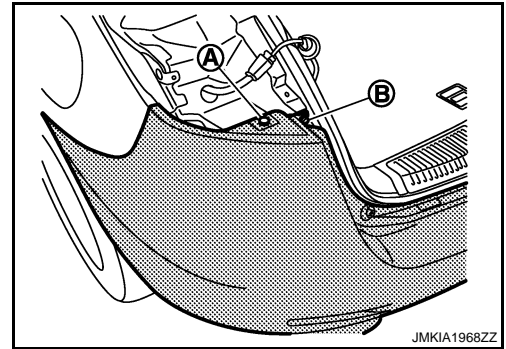

5. Remove rear mudguard. Refer to [EXT-25. "Removal and Installation"](#).
6. Remove clips (A) of bumper fascia (1) underside (LH/RH).

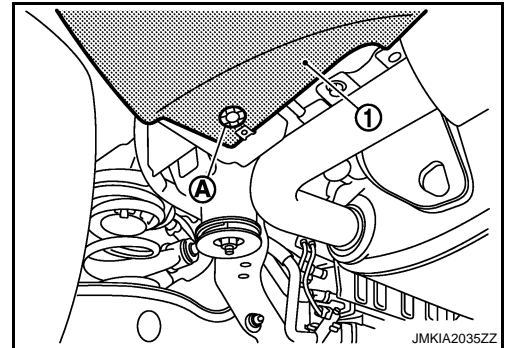

7. Remove clips (A) of bumper fascia underside.

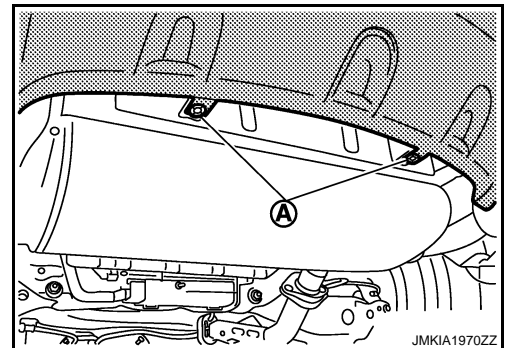

8. Remove screws (A) of bumper fascia front end upper (LH/RH).

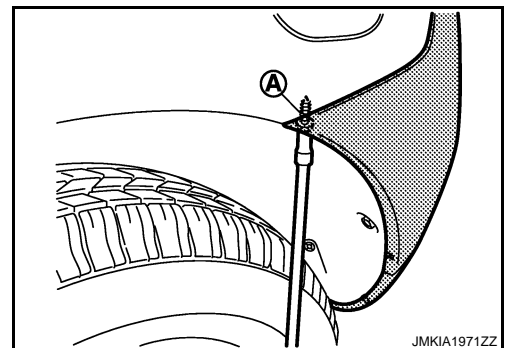

REAR BUMPER

< ON-VEHICLE REPAIR >

9. Pull to release bumper fascia assembly (1) from bumper side bracket.

 : Pawl

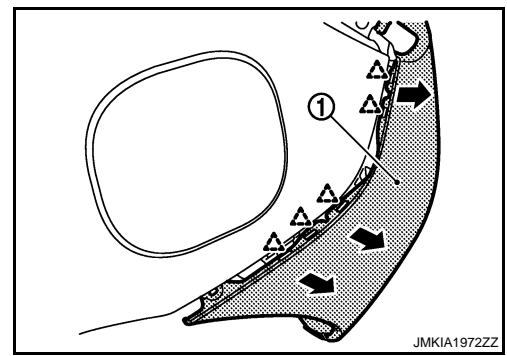

10. Remove bumper fascia assembly.

CAUTION:

When removing bumper fascia assembly, 2 workers are required so as to prevent it from dropping.

11. Remove the following parts after removing rear bumper fascia.

- Bumper side bracket (LH/RH)
Remove bumper side bracket (1) fixing screws (A) (LH/RH), and then remove bumper side bracket (LH/RH).

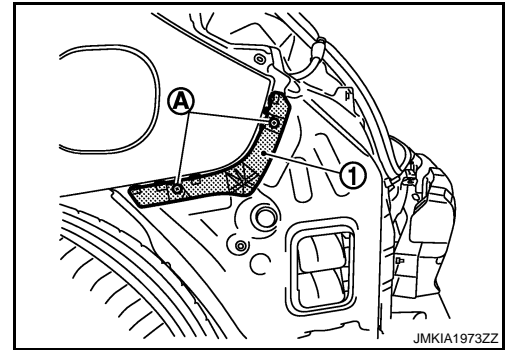

- Reflex reflector (LH/RH)
Remove reflex reflector (1) fixing screws (A) (LH/RH), and then remove reflex reflector (LH/RH).

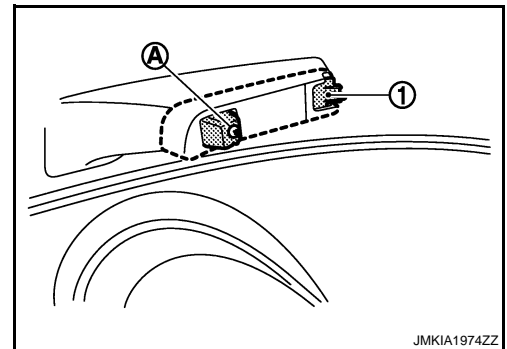

12. Remove energy absorber.
13. Remove bumper reinforcement mounting nuts (LH/RH), and then remove bumper reinforcement.
14. Remove bumper stay mounting bolts, and then remove bumper stay.

INSTALLATION

Install in the reverse order of removal.

NOTE:

After installing, perform fitting adjustment.

Portion		Clearance
Rear bumper – Rear fender	A – A	0.0 – 1.0 mm (0.000 – 0.039 in)
Rear bumper – Rear combination lamp	B – B	0.5 – 3.5 mm (0.020 – 0.138 in)
Rear bumper – Back door	C – C	4.0 – 8.0 mm (0.157 – 0.315 in)
Rear bumper – Back door	D – D	5.0 – 9.0 mm (0.197 – 0.354 in)

A
B
C
D
E
F
G
H
I
J
EXT
L
M
N
O
P

FRONT GRILLE

< ON-VEHICLE REPAIR >

FRONT GRILLE

Exploded View

INFOID:000000003350467

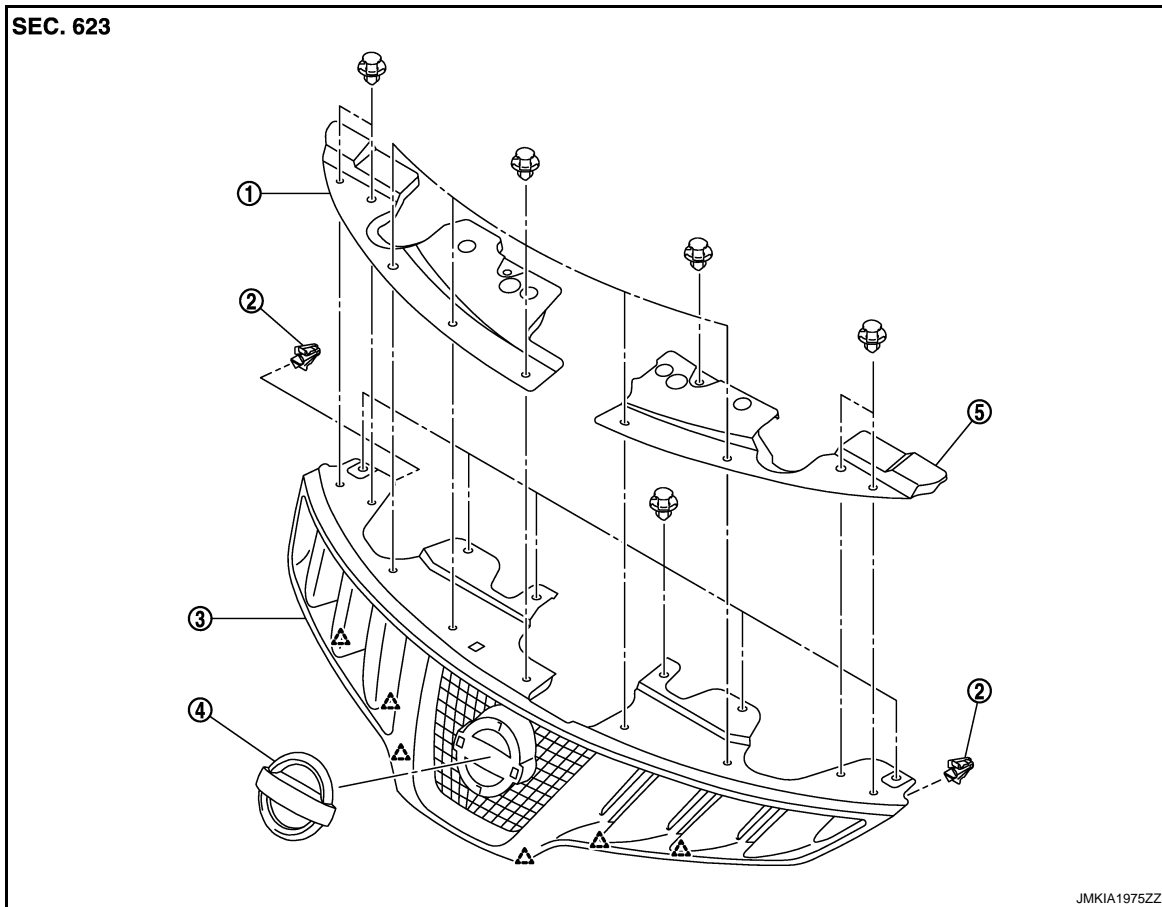

1. Radiator core support cover RH

2. Fastener

3. Front grille assembly

4. Front emblem

5. Radiator core support cover LH

△ : Pawl

Removal and Installation

INFOID:000000003350468

REMOVAL

1. Fully open hood assembly.
2. Remove radiator core support cover LH (1) fixing clips (A), and then remove radiator core support cover LH.
3. Remove radiator core support cover RH (2) fixing clips (B), and then remove radiator core support cover RH.

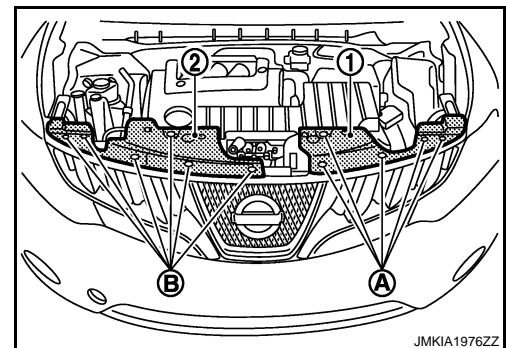

FRONT GRILLE

< ON-VEHICLE REPAIR >

4. Remove front grille (1) fixing clips (A).

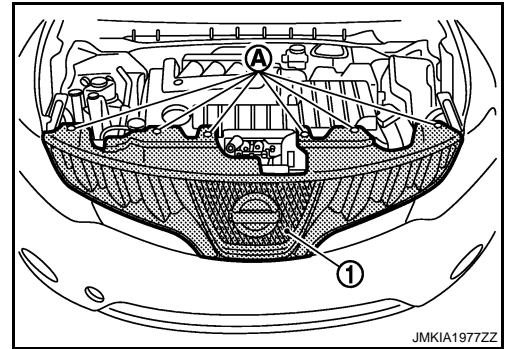

5. Disengage fastener (A) of fixing front grille (1) with plier (B).

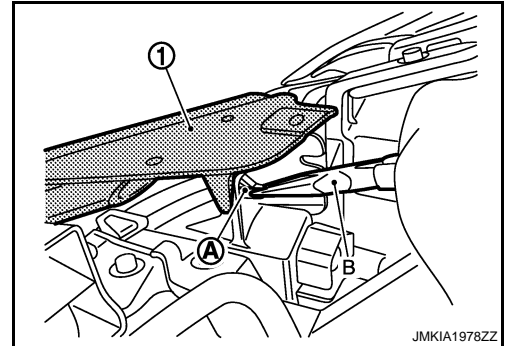

6. Pull front grille (1) horizontally toward vehicle front, and then remove front grille.

 : Pawl

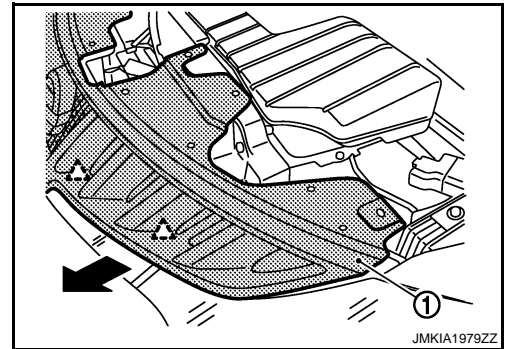

7. Remove the front emblem after removing front grille.
- Remove emblem (1) fixing pawls.
 - Remove emblem from front grille (2).

 : Pawl

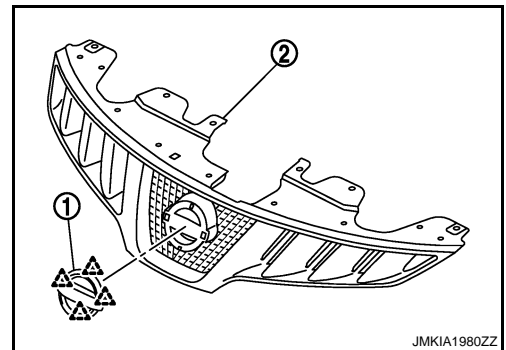

INSTALLATION

Install in the reverse order of removal.

A
B
C
D
E
F
G
H
I
J
EXT
L
M
N
O
P

COWL TOP

< ON-VEHICLE REPAIR >

COWL TOP

Exploded View

INFOID:000000003350469

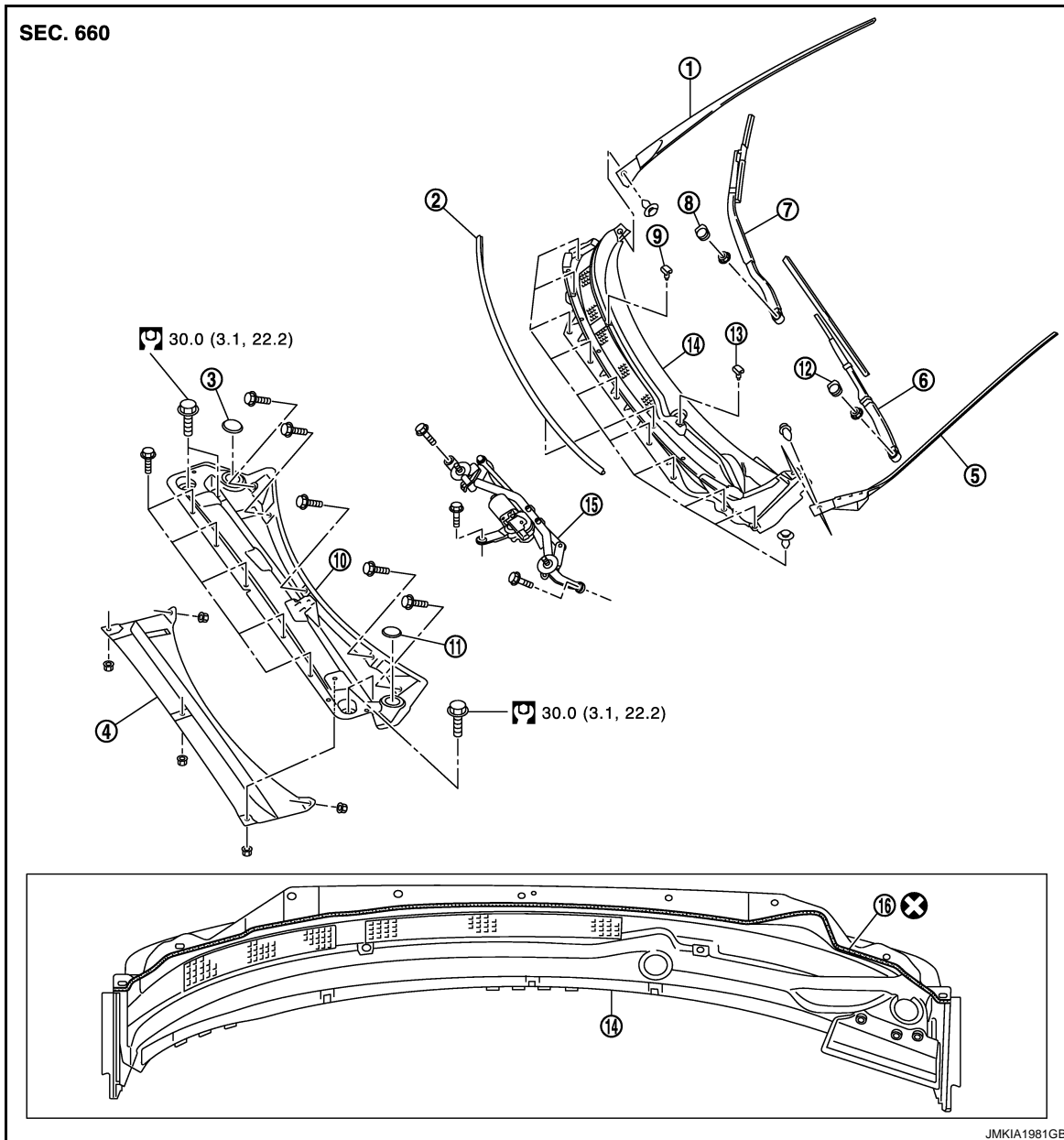

- | | | |
|---------------------------------|-------------------------------|---------------------------------|
| 1. Windshield side molding RH | 2. Cowl top seal | 3. Rubber plug RH |
| 4. Extension cowl top | 5. Windshield side molding LH | 6. Front wiper arm and blade LH |
| 7. Front wiper arm and blade RH | 8. Front wiper arm cover RH | 9. Washer nozzle RH |
| 10. Extension cowl top | 11. Rubber plug LH | 12. Front wiper arm cover LH |
| 13. Washer nozzle LH | 14. Cowl top cover | 15. Front wiper drive assembly |
| 16. EPT sealer | | |

Refer to [GI-4, "Components"](#) for symbols in the figure.

Removal and Installation

INFOID:000000003350470

REMOVAL

1. Fully open hood assembly.

COWL TOP

< ON-VEHICLE REPAIR >

2. Remove front wiper arm blade (LH/RH). Refer to [WW-126. "Removal and Installation"](#).
3. Remove windshield side molding (1) fixing clips (A) (LH/RH).

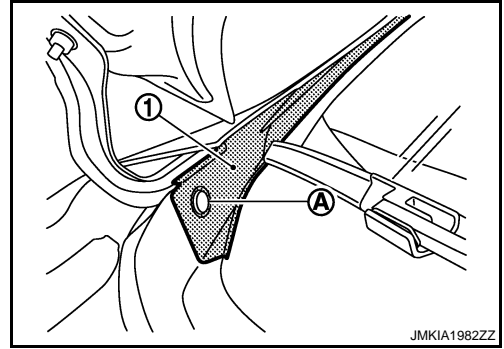

4. Disconnect front washer tube connector (1).

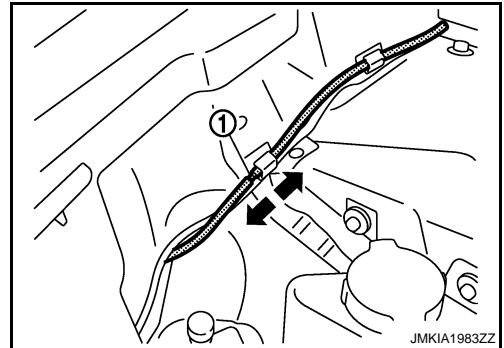

5. Remove cowl top cover fixing clips.
6. Pull forward to release cowl top cover (1) from windshield glass.

CAUTION:

When performing the procedure after removing cowl top cover, cover the lower end of windshield glass with urethane etc.

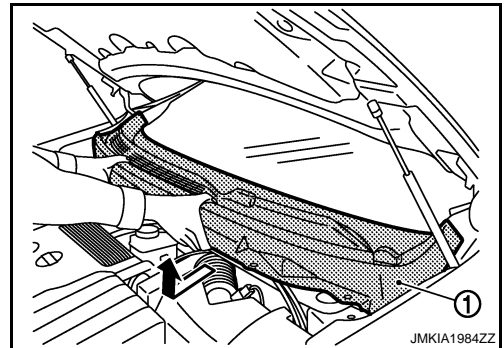

7. Remove the following parts after removing cowl top cover.
 - Cowl top seal
 - Washer nozzle (LH/RH)
 - Washer tube
 - EPT sealer
8. Remove front wiper drive assembly. Refer to [WW-130. "Removal and Installation"](#).
9. Remove brake reservoir tank (1) fixing nuts (A).
10. Remove brake fluid level switch harness clips (B).

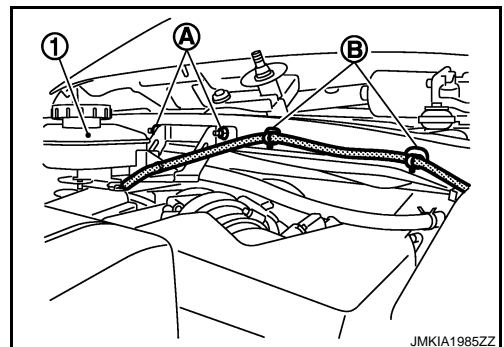

11. Remove extension cowl top mounting bolts, and then remove extension cowl top.
12. Remove dash lower insulator upper mounting nuts, and then remove dash lower insulator upper.

COWL TOP

< ON-VEHICLE REPAIR >

INSTALLATION

Install in the reverse order of removal.

CAUTION:

- When installing cowl top cover, check that blind clips are securely fitted in panel holes on body, and then press them in.
- Always replace cowl top cover EPT sealer on rear of vehicle with a new one when installing old cowl top cover.
- After installing, perform adjustment of wiper arms. Refer to [WW-126, "Adjustment"](#).

FENDER PROTECTOR

< ON-VEHICLE REPAIR >

FENDER PROTECTOR

FENDER PROTECTOR

FENDER PROTECTOR : Exploded View

INFOID:000000003350471

FENDER PROTECTOR

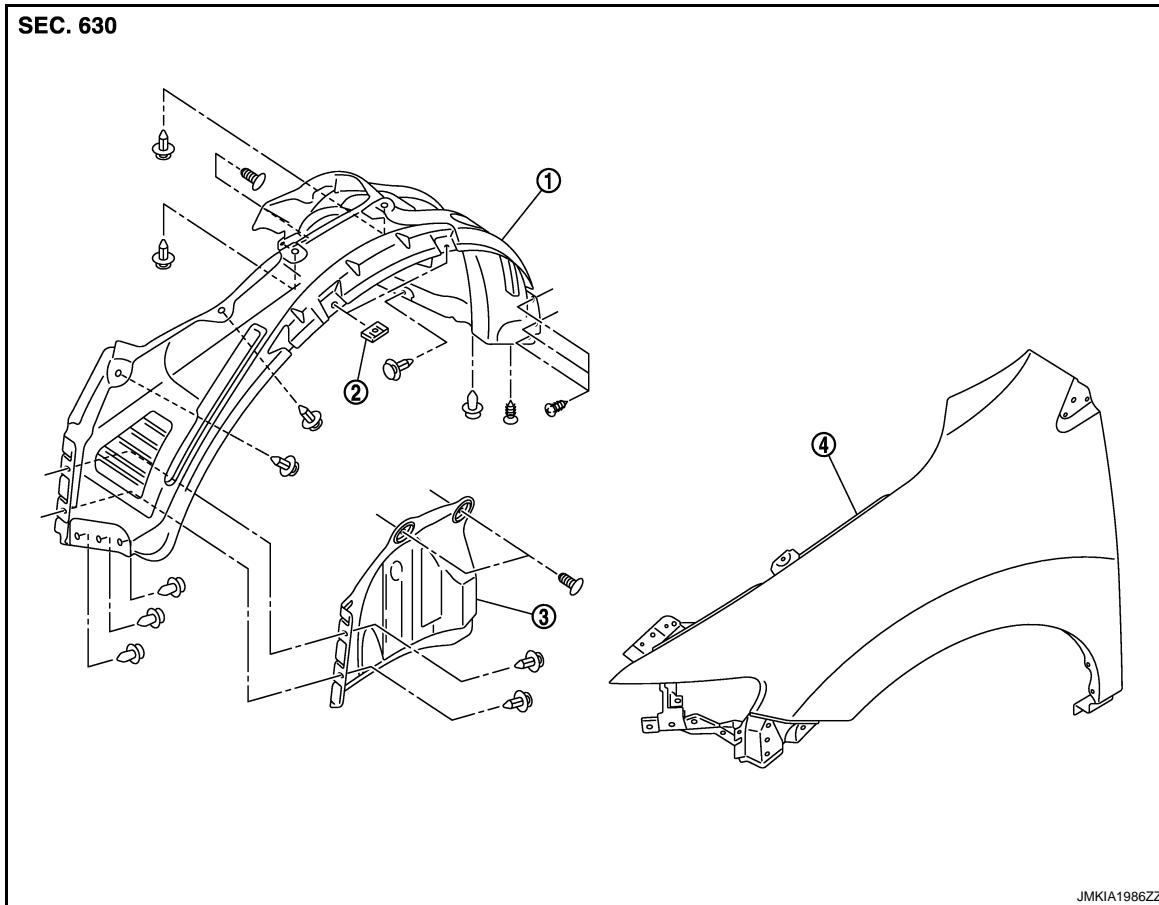

1. Fender protector
4. Front fender

2. Fender clip

3. Splash guard

FENDER PROTECTOR : Removal and Installation

INFOID:000000003350472

REMOVAL

1. Remove front mudguard (LH/RH). Refer to [EXT-25, "Removal and Installation"](#).
2. Remove splash guard fixing clips and then remove splash guard.
3. Remove front fender protector fixing clips.
4. Release front fender protector upper fixing clip downward, and then remove front fender protector.

INSTALLATION

Install in the reverse order of removal.

REAR WHEEL HOUSE PROTECTOR

FENDER PROTECTOR

< ON-VEHICLE REPAIR >

REAR WHEEL HOUSE PROTECTOR : Exploded View

INFOID:000000003544511

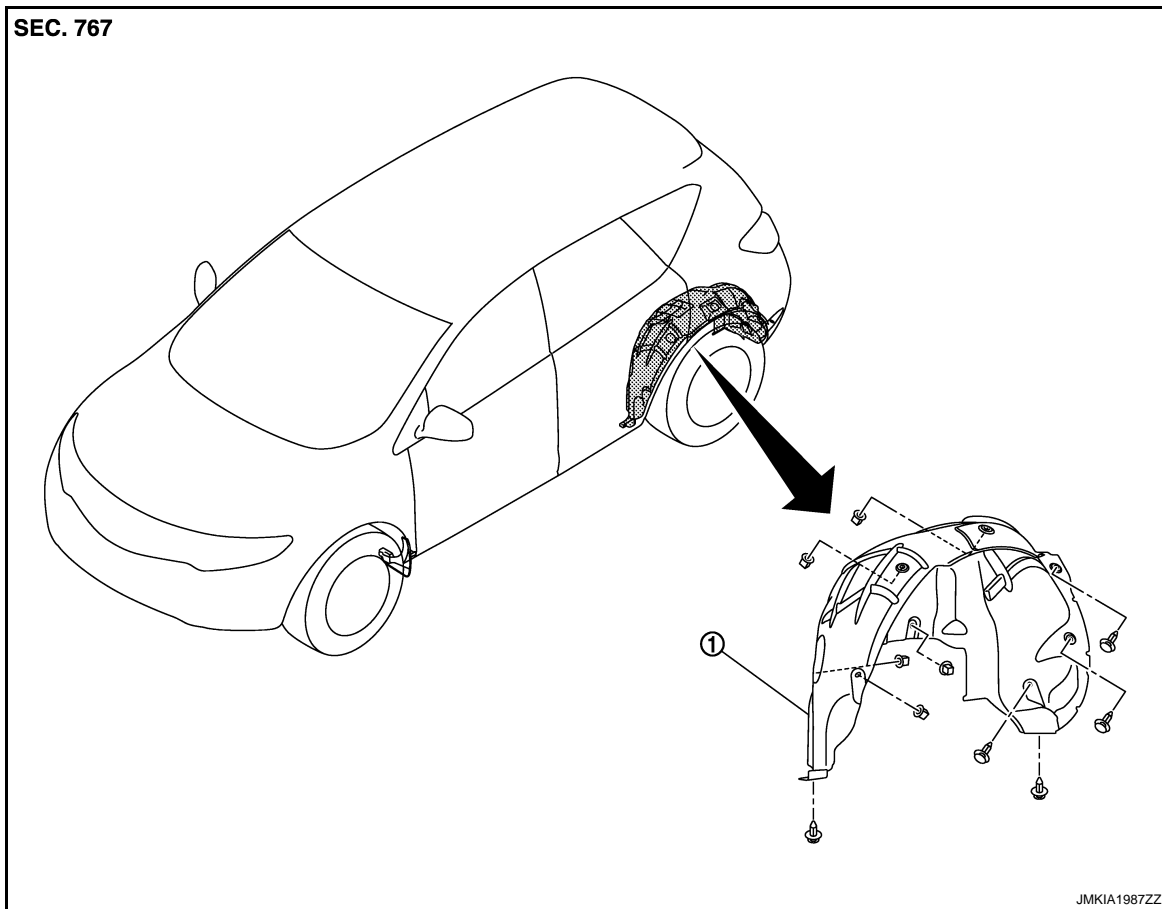

1. Rear wheel house protector

REAR WHEEL HOUSE PROTECTOR : Removal and Installation

INFOID:000000003544512

REMOVAL

1. Remove rear mudguard. Refer to [EXT-25. "Removal and Installation"](#).
2. Remove clip (A) of rear bumper fascia (1).

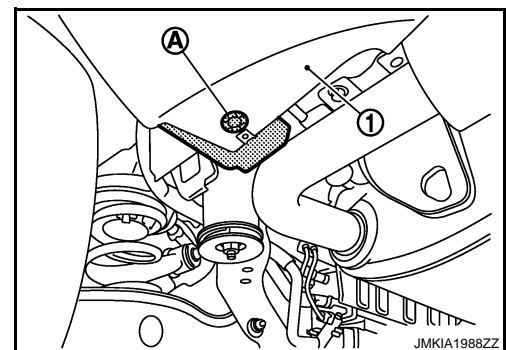

3. Remove rear wheel house protector fixing clips.
4. Remove rear wheel house protector fixing plastic nuts and then remove rear wheel house protector.

INSTALLATION

Install in the reverse order of removal.

MUDGUARD

< ON-VEHICLE REPAIR >

MUDGUARD

Exploded View

INFOID:000000003350473

MUDGUARD

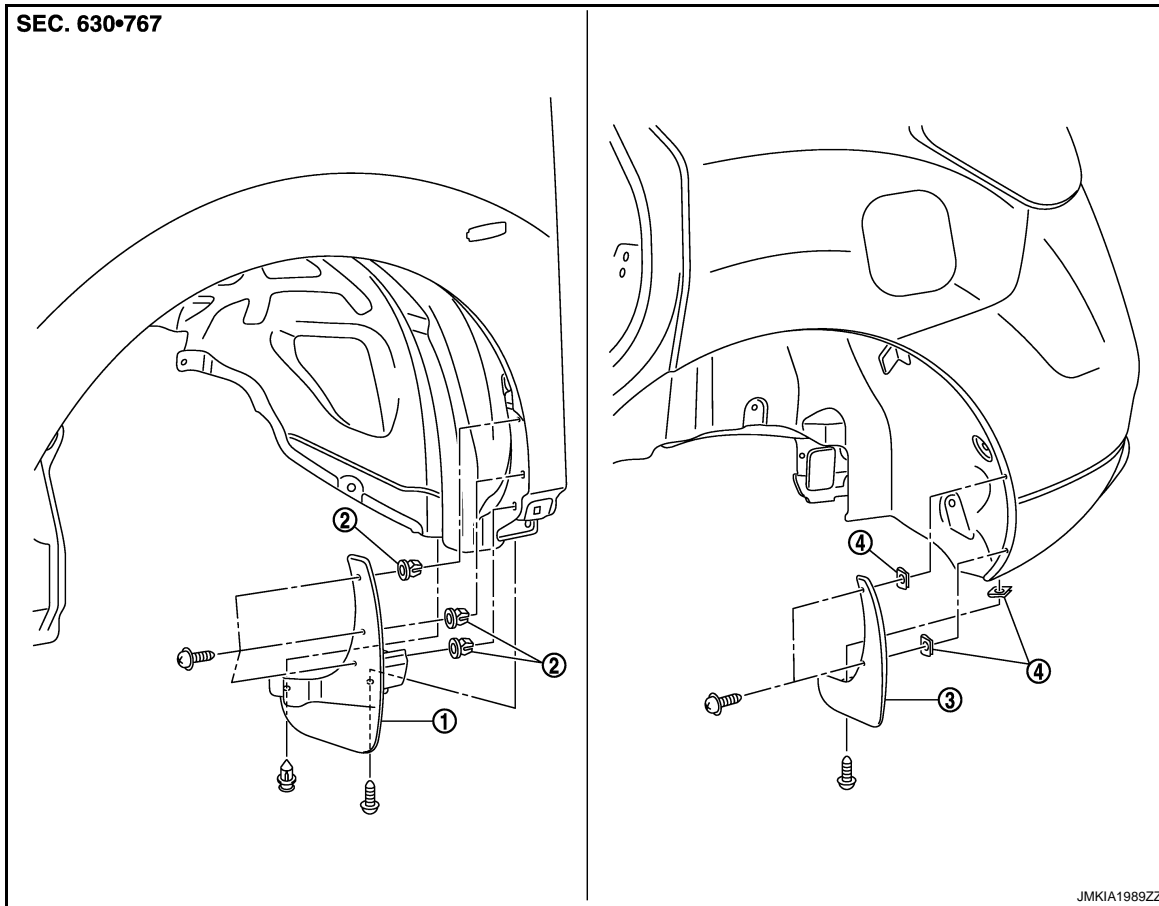

1. Front mudguard
4. J-nut

2. Grommet

3. Rear mudguard

Removal and Installation

INFOID:000000003350474

REMOVAL

FRONT MUDGUARD

1. Remove front mudguard fixing screws.
2. Remove front mudguard fixing clip.
3. Remove front mudguard.

REAR MUDGUARD

1. Remove rear mudguard fixing screws.
2. Remove rear mudguard.

INSTALLATION

Install in the reverse order of removal.

A
B
C
D
E
F
G
H
I
J

EXT

L
M
N
O
P

FLOOR SIDE FAIRING

< ON-VEHICLE REPAIR >

FLOOR SIDE FAIRING

Exploded View

INFOID:000000003350475

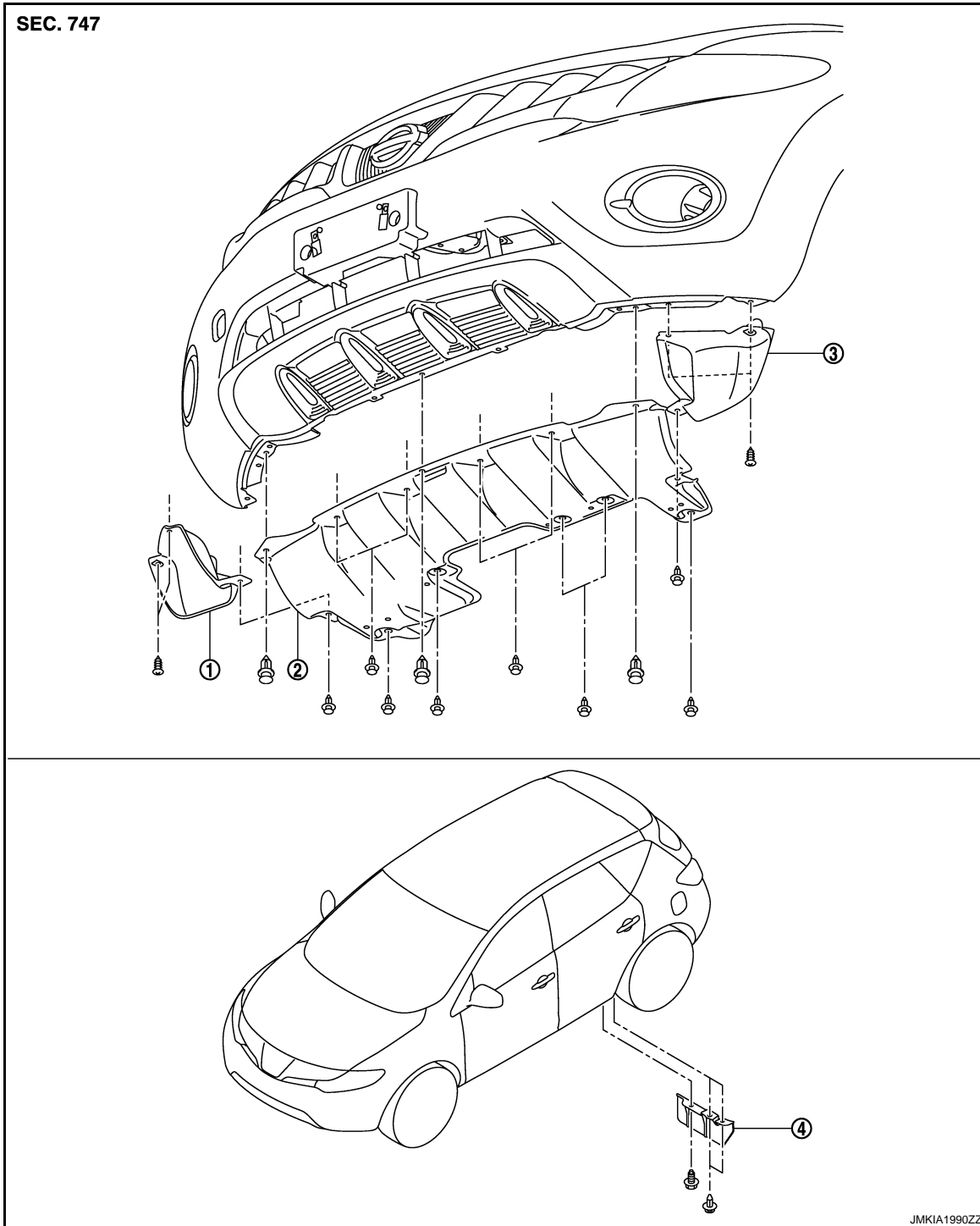

- 1. Bumper lower finisher RH
- 4. Wind deflector

- 2. Front under cover

- 3. Bumper lower finisher LH

Removal and Installation

INFOID:000000003350476

REMOVAL

FRONT UNDER COVER

Revision: 2008 October

EXT-26

2009 Murano

FLOOR SIDE FAIRING

< ON-VEHICLE REPAIR >

1. Remove front under cover mounting clips.
2. Remove front under cover.

WIND DEFLECTOR

1. Remove wind deflector (1) fixing clips (A) and bolt (B).
2. Remove wind deflector.

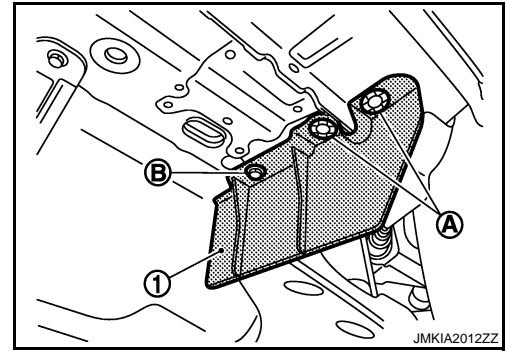

INSTALLATION

Install in the reverse order of removal.

A
B
C
D
E
F
G
H
I
J
L
M
N
O
P

EXT

ROOF RAIL

< ON-VEHICLE REPAIR >

ROOF RAIL

Exploded View

INFOID:000000003350479

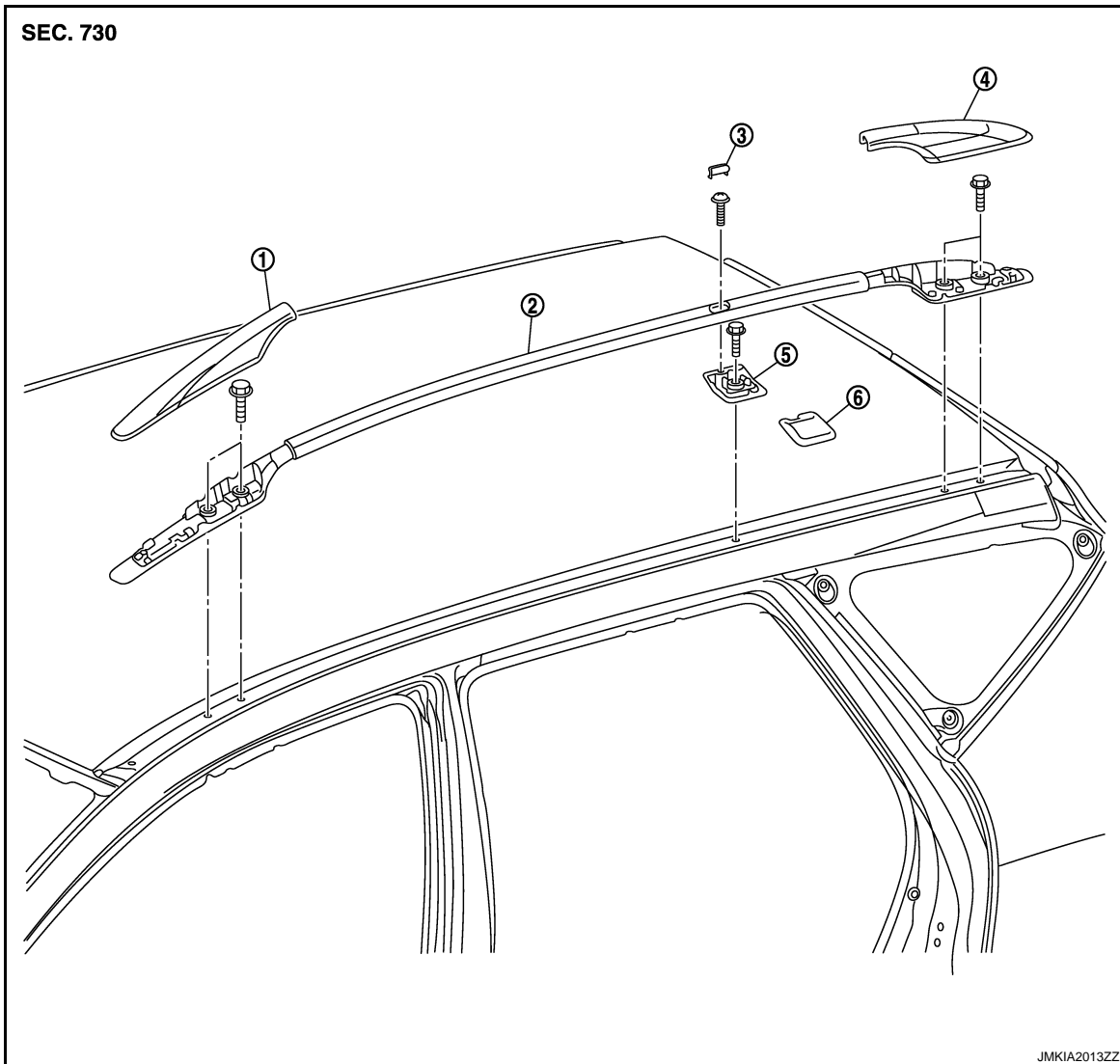

1. Front roof rail cover

2. Roof rail assembly

3. Center roof rail cover

4. Rear roof rail cover

5. Center leg assembly

6. Center leg cover

Removal and Installation

INFOID:000000003350480

REMOVAL

1. Remove front roof rail cover (1) with remover tool (A).

CAUTION:

Apply protective tape (B) around the roof rail.

 : Pawl

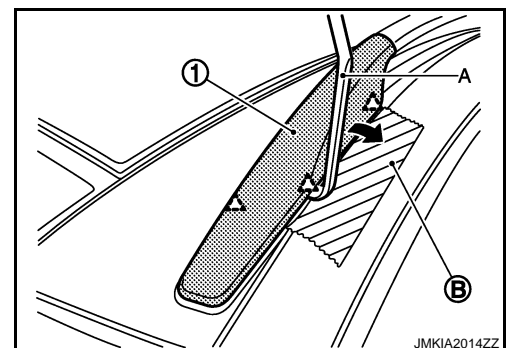

ROOF RAIL

< ON-VEHICLE REPAIR >

2. Remove center roof rail cover (1) with remover tool (A).

 : Pawl

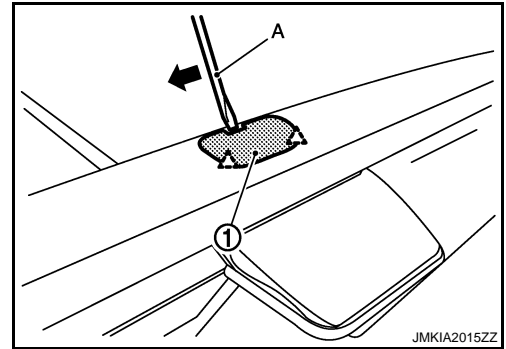

3. Remove rear roof rail cover (1) with remover tool (A).

CAUTION:
Apply protective tape (B) around the roof rail.

 : Pawl

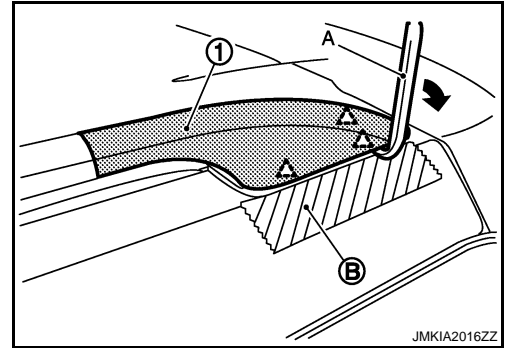

4. Remove roof rail mounting bolts, and then remove roof rail assembly.

5. Pull to the side, disengage pawls and remove center leg cover (1).

 : Pawl

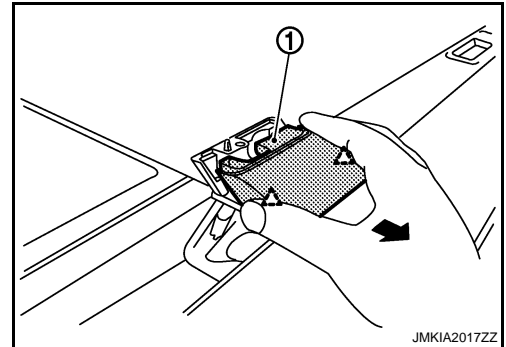

6. Remove roof rail center leg assembly mounting bolt, and then remove roof rail center leg assembly.

INSTALLATION

Install in the reverse order of removal.

A
B
C
D
E
F
G
H
I
J
EXT
L
M
N
O
P

ROOF SIDE MOLDING

< ON-VEHICLE REPAIR >

ROOF SIDE MOLDING

NORMAL ROOF

NORMAL ROOF : Exploded View

INFOID:000000003350477

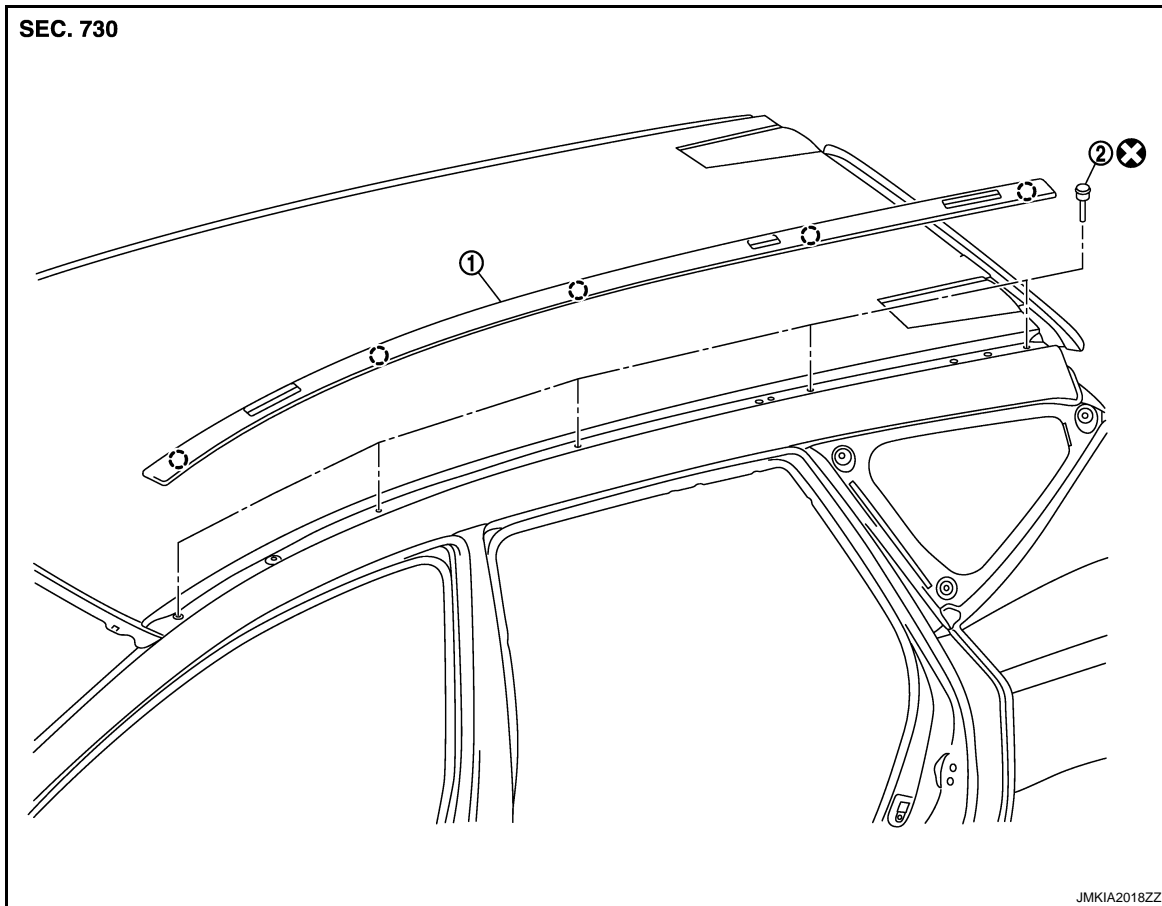

1. Roof side molding 2. Roof side molding clip

○ : Clip

Refer to [GI-4, "Components"](#) for symbols in the figure.

NORMAL ROOF : Removal and Installation

INFOID:000000003350478

REMOVAL

1. Remove roof rail assembly and roof rail center leg assembly. Refer to [EXT-28, "Removal and Installation"](#).
2. Disengage roof side molding (1) fixing clips with remover tool (A).

CAUTION:

Apply protective tape (B) around the roof side molding.

○ : Clip

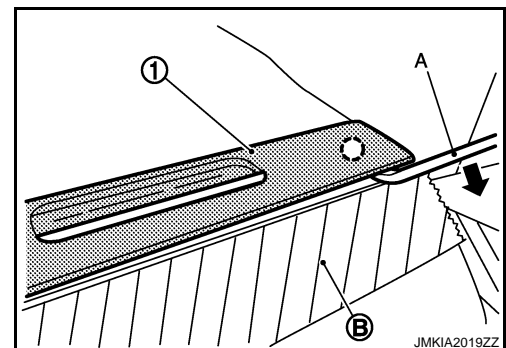

INSTALLATION

Install in the reverse order of removal.

ROOF SIDE MOLDING

< ON-VEHICLE REPAIR >

CAUTION:

To install roof side molding, check if all clips are matched over holes of panel on vehicle, then push it.

SUNROOF : Exploded View

INFOID:000000003544596

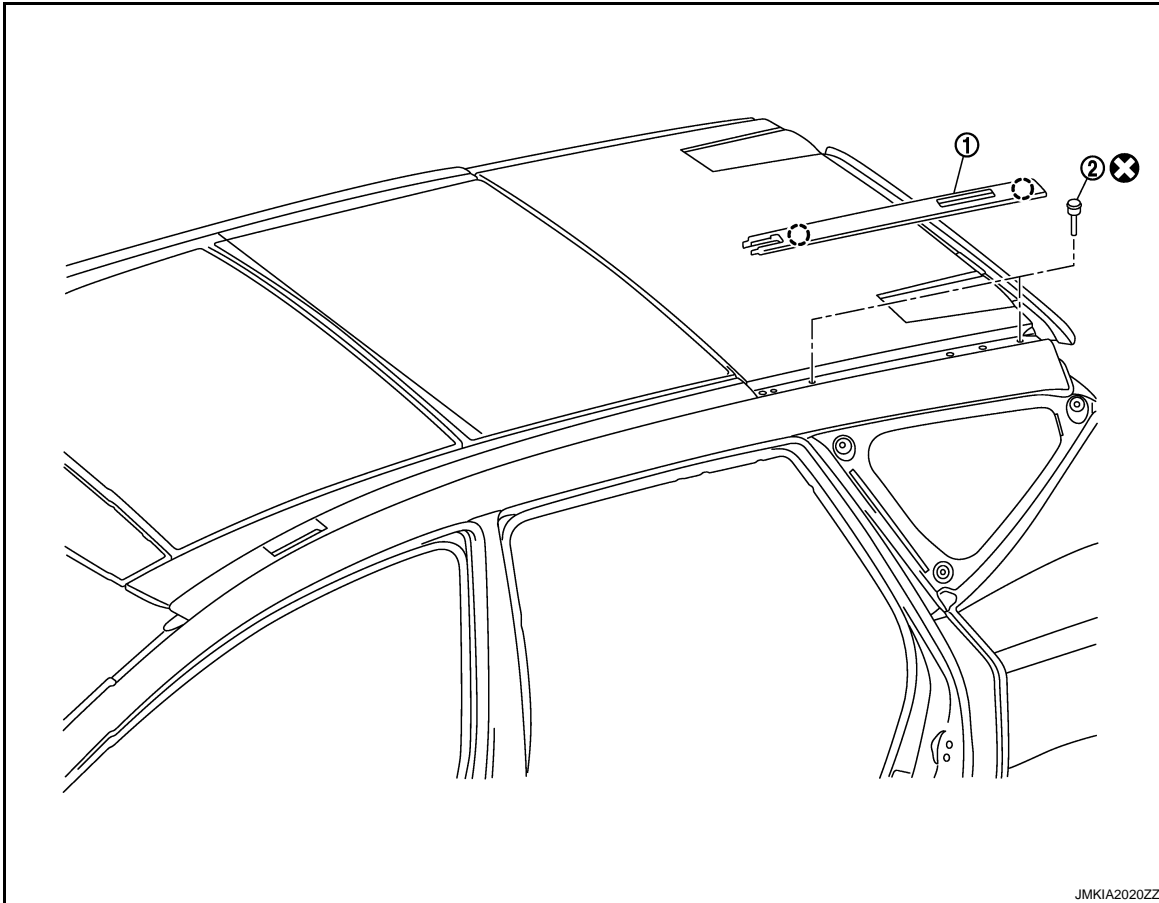

1. Roof side molding

2. Roof side molding clip

○ : Clip

Refer to [GI-4, "Components"](#) for symbols in the figure.

SUNROOF : Removal and Installation

INFOID:000000003544597

REMOVAL

1. Remove roof rail assembly and roof rail center leg assembly. (with ROOF RAIL)
Refer to [EXT-28, "Removal and Installation"](#).

2. Disengage roof side molding (1) fixing clips with remover tool (A).

CAUTION:

Apply protective tape (B) around the roof side molding.

○ : Clip

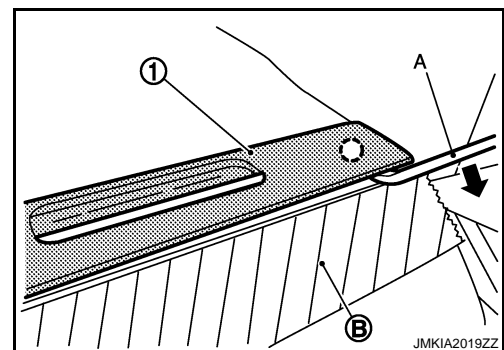

INSTALLATION

ROOF SIDE MOLDING

< ON-VEHICLE REPAIR >

Install in the reverse order of removal.

CAUTION:

- Insert front end of roof side molding (1) into roof side finisher.

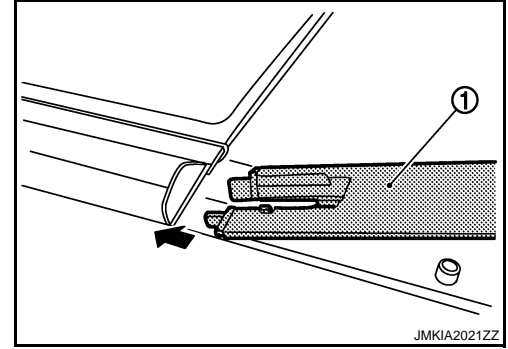

- To install roof side molding, check if all clips are matched over holes of panel on vehicle, then push it.

DOOR OUTSIDE MOLDING

< ON-VEHICLE REPAIR >

DOOR OUTSIDE MOLDING

Exploded View

INFOID:000000003350481

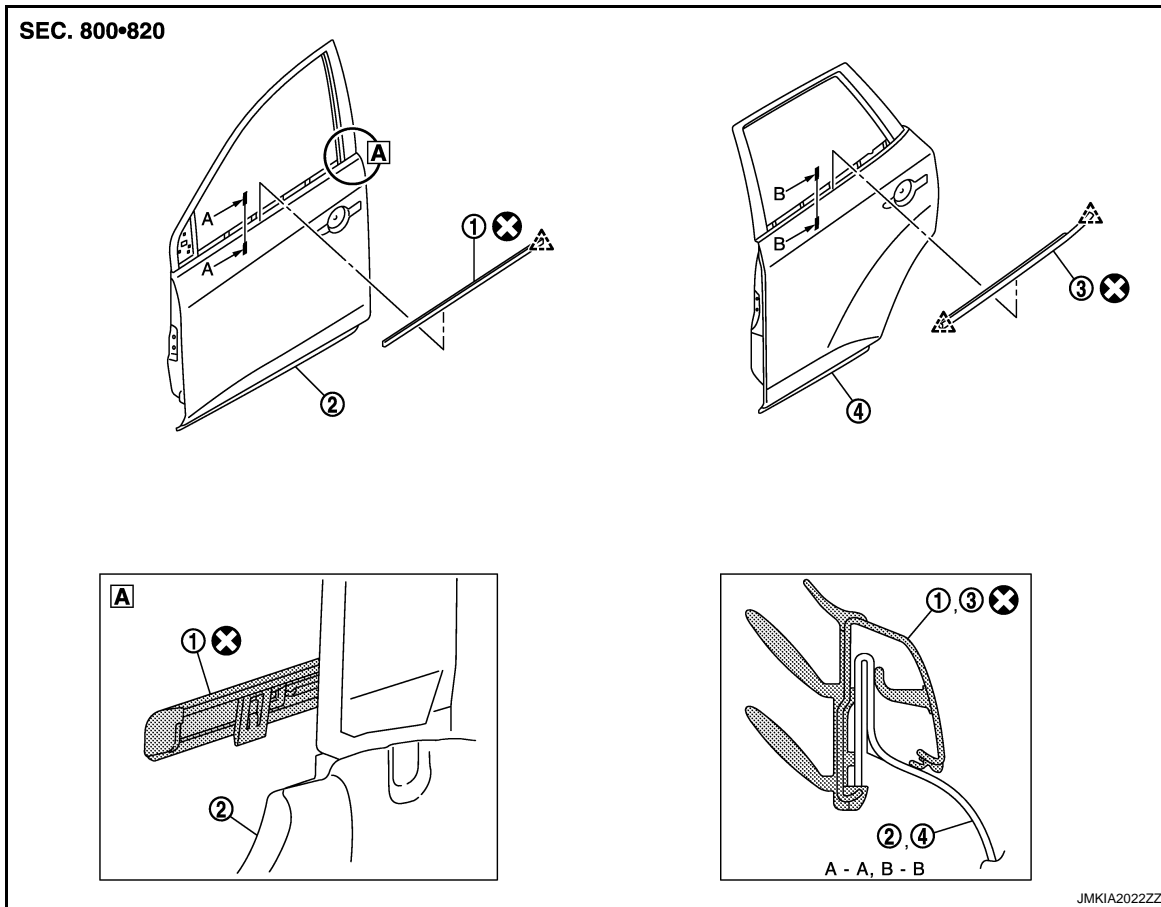

- 1. Front door outside molding
- 2. Front door assembly
- 3. Rear door outside molding
- 4. Rear door assembly

△ : Pawl

Refer to [GI-4. "Components"](#) for symbols in the figure.

Removal and Installation

INFOID:000000003350482

REMOVAL

FRONT DOOR OUTSIDE MOLDING

1. Fully open door window.
2. Insert a remover tool (A) into lower space.
3. Disengage pawls of fixing front door outside molding (1) with flat blade screw driver (B).

△ : Pawl

CAUTION:

Apply protection tape (C) around outer circumference of front door.

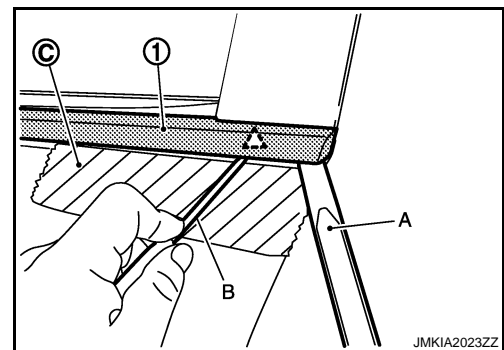

JMKIA2023ZZ

A
B
C
D
E
F
G
H
I
J

EXT

L

M

N

O

P

DOOR OUTSIDE MOLDING

< ON-VEHICLE REPAIR >

4. Twist and pull up to upper side, and then remove front door outside molding (1).

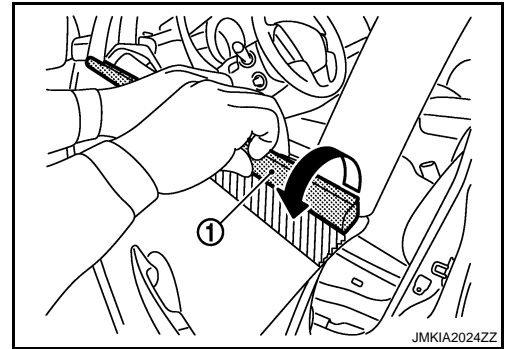

REAR DOOR OUTSIDE MOLDING

1. Fully open door window.
2. Insert a remover tool (A) into lower space.
3. Disengage pawls of fixing rear door outside molding (1) with flat blade screw driver (B).

 : Pawl

CAUTION:

Apply protection tape (C) around outer circumference of rear door.

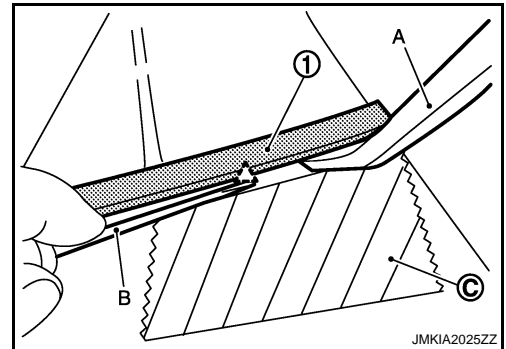

4. Twist and pull up to upper side, and then remove rear door outside molding (1).

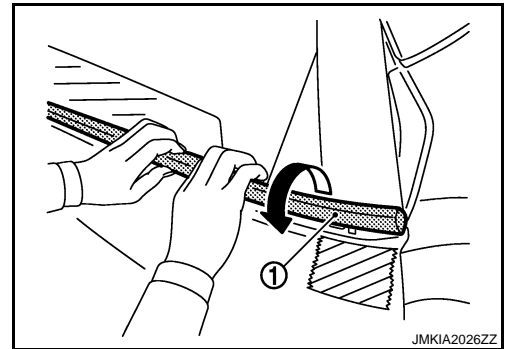

INSTALLATION

Install in the reverse order of removal.

DOOR OUTSIDE LOWER MOLDING

< ON-VEHICLE REPAIR >

DOOR OUTSIDE LOWER MOLDING

Exploded View

INFOID:000000003573997

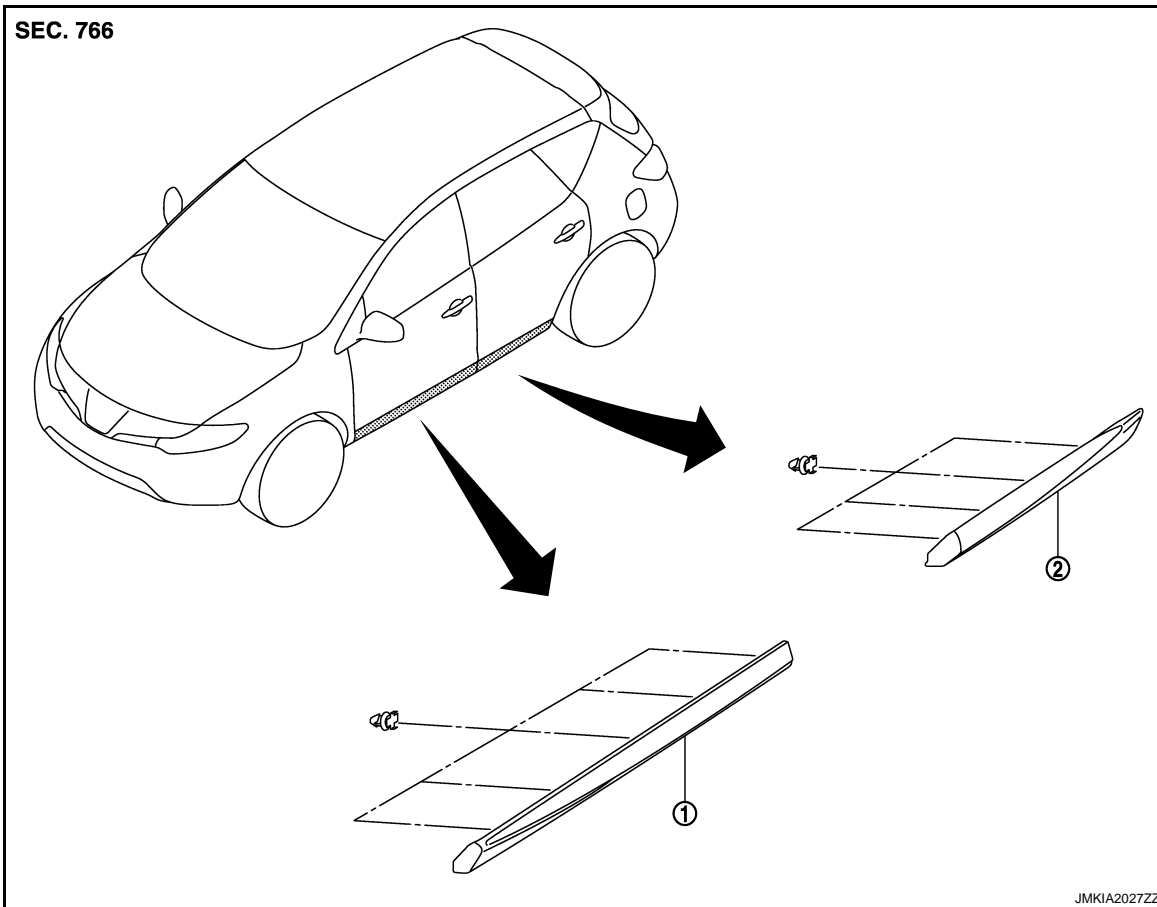

1. Front door outside lower molding
2. Rear door outside lower molding

Removal and Installation

INFOID:000000003574050

REMOVAL

FRONT DOOR OUTSIDE LOWER MOLDING

1. Using a remover tool (A), disengage the clips from the front door outside lower molding (1) by starting from the rear.

CAUTION:

- Apply a protective tape (B) on the door to protect the painted surface from damage.
- Disengage the clips slowly and carefully.
- Never pull the front door outside lower molding.

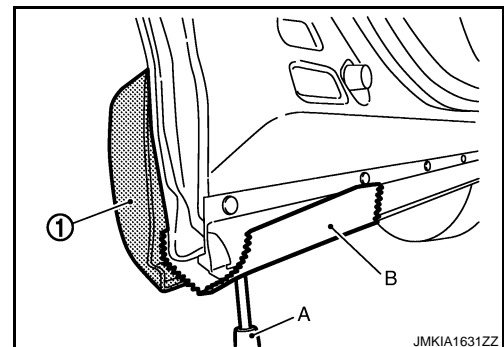

2. Remove front door outside lower molding.

REAR DOOR OUTSIDE LOWER MOLDING

A
B
C
D
E
F
G
H
I
J

EXT

L
M
N
O
P

DOOR OUTSIDE LOWER MOLDING

< ON-VEHICLE REPAIR >

1. Using a remover tool (A), disengage the clips from the rear door outside lower molding (1) by starting from the rear.

CAUTION:

- Apply a protective tape (B) on the door to protect the painted surface from damage.
- Disengage the clips slowly and carefully.
- Never pull the front door outside lower molding.

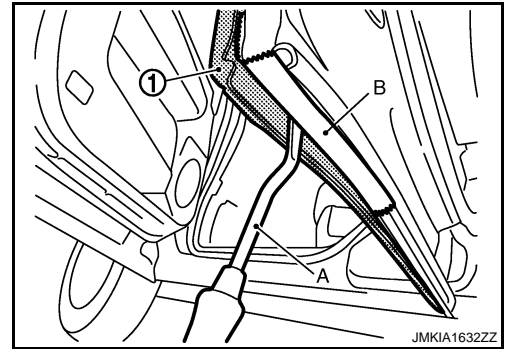

2. Remove rear door outside lower molding.

INSTALLATION

Install in the reverse order of removal.

CAUTION:

- When installing, check visually the door outside lower molding and the clips, then replace them with new parts if they have been damaged.
- When installing door outside lower molding, check that clips are securely fitted in panel holes on body, and then press them in.

DOOR PARTING SEAL

< ON-VEHICLE REPAIR >

DOOR PARTING SEAL

Exploded View

INFOID:000000003350483

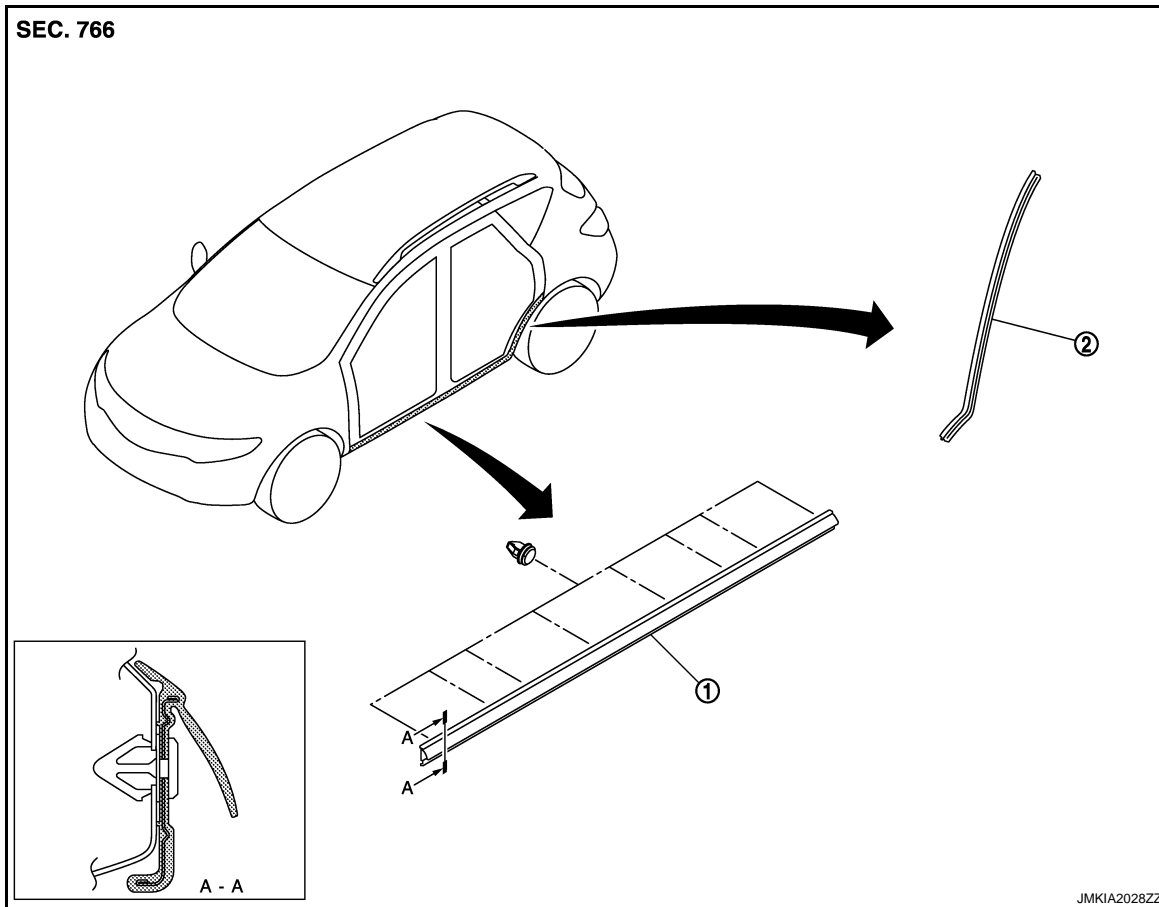

1. Door parting seal

2. Rear door parting seal

EXT

Removal and Installation

INFOID:000000003350484

REMOVAL

DOOR PARTING SEAL

1. Fully open front door.
2. Using a remover tool (A), disengage the clips from the door parting seal (1).

CAUTION:

- Disengage the clips slowly and carefully.
- Never pull the door parting seal strongly.

 : Clip

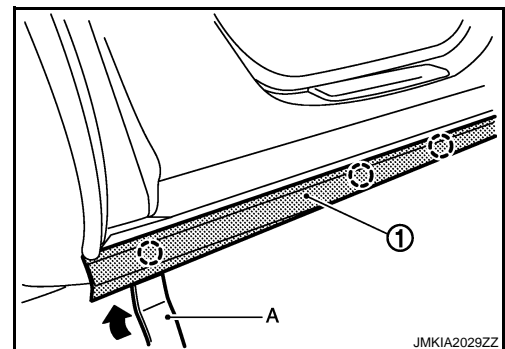

3. Remove front door parting seal.

REAR DOOR PARTING SEAL

1. Fully open rear door.

DOOR PARTING SEAL

< ON-VEHICLE REPAIR >

2. Remove rear door parting seal.
Pull back rear door parting seal (1).

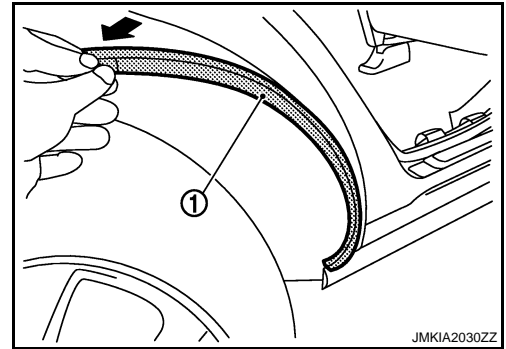

INSTALLATION

Install in the reverse order of removal.

CAUTION:

- When installing, check visually the fillet molding and the clips, then replace them with new parts if they have been damaged.
- When installing door parting seal, check that blind clips are securely fitted in panel holes on body, and then press them in.

DOOR SASH COVER

< ON-VEHICLE REPAIR >

DOOR SASH COVER

Exploded View

INFOID:000000003544670

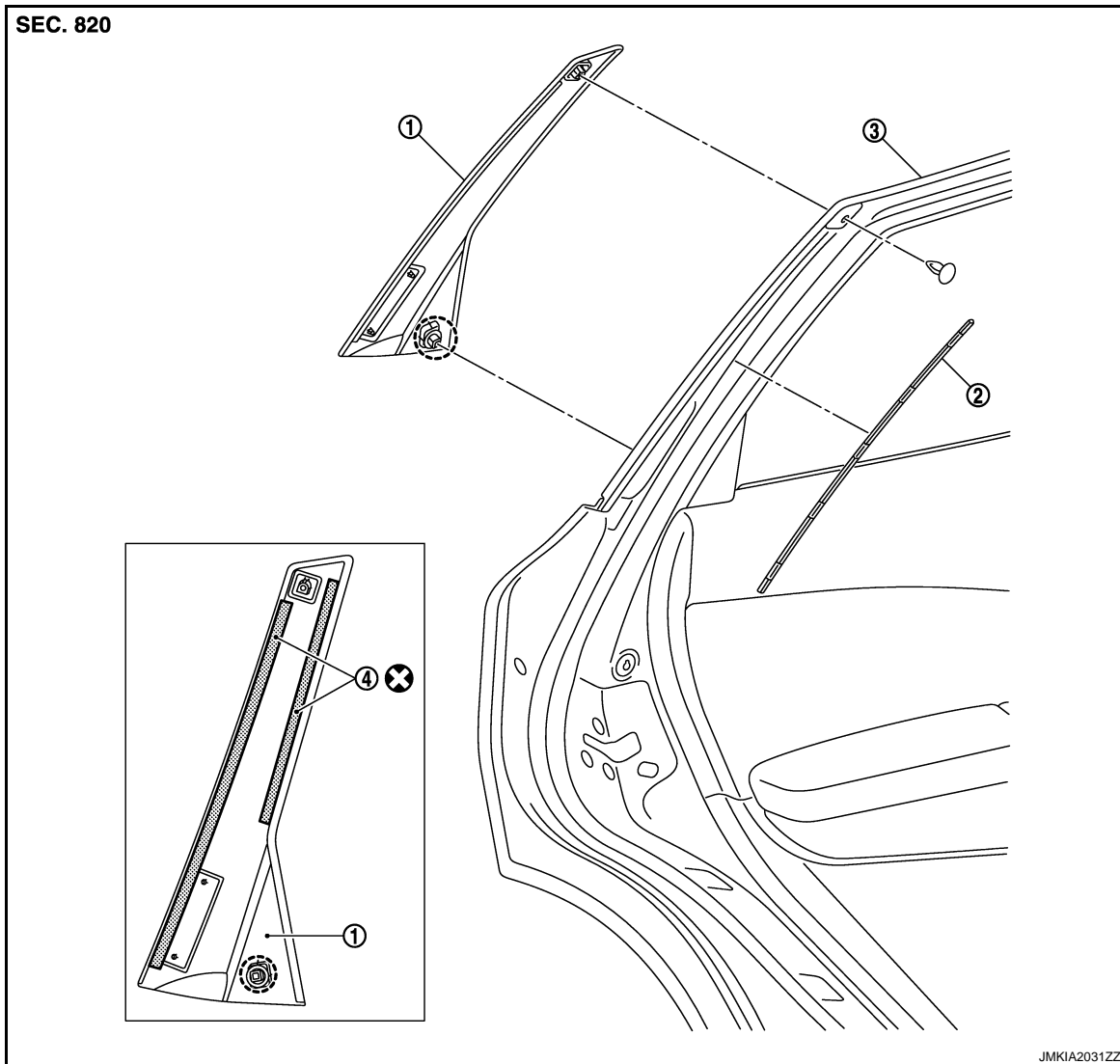

1. Rear door sash cover
2. Rear door sash molding
3. Rear door assembly
4. Double-faced adhesive tape

 : Clip

Refer to [GI-4. "Components"](#) for symbols in the figure.

Removal and Installation

INFOID:000000003544671

REMOVAL

1. Remove rear door outside molding. Refer to [EXT-33. "Removal and Installation"](#).

A
B
C
D
E
F
G
H
I
J
EXT
L
M
N
O
P

DOOR SASH COVER

< ON-VEHICLE REPAIR >

2. Remove rear door sash molding (1) with remover tool (A).

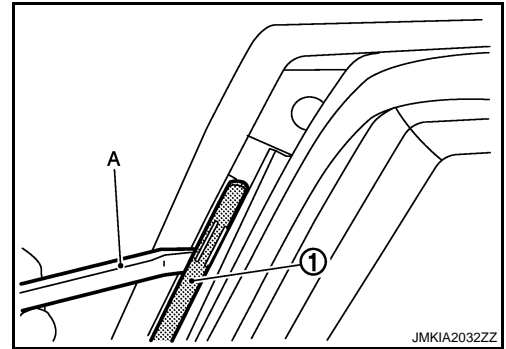

3. Remove rear door weather-strip (1) fixing clip (A) with remover tool (B).
4. Release roof portion of rear door weather-strip.

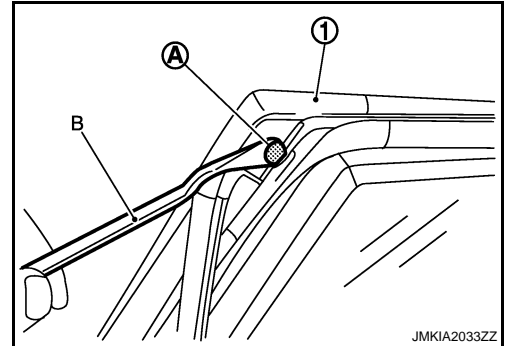

5. Release roof portion of glass run.
6. Release rear door sash cover connection between rear door panel and cover (1), using a remover tool (A) and cutter knife (B), and take off double-faced adhesive tape.

CAUTION:

Never use a material for remover tool (A) which could damage door panel.

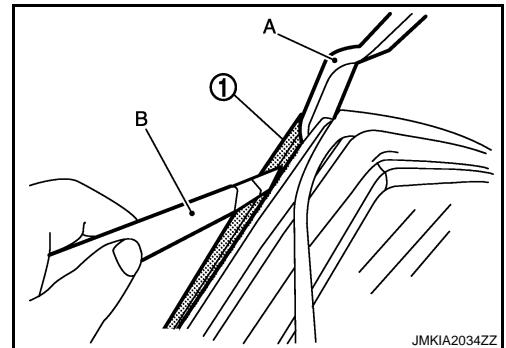

7. Remove rear door sash cover fixing clips, and then remove rear door sash cover.

INSTALLATION

Install in the reverse order of removal.

CAUTION:

- Replace double-faced adhesive tape on back of cover with a new tape if rear door sash cover is reused.
- Never let air between contact surfaces when installing.
- Remove double-faced adhesive tape remaining on body and back of cover using double-faced adhesive tape remover when removing rear door sash cover.
- Install after cleaning adhesive parts of door side and back of rear door sash cover.
- To secure contact, do not wash vehicle within 24 hours after installation.