

A
EC
C
D
E
F
G
H
I
J
K
L
M
N
O
P

SECTION EC

ENGINE CONTROL SYSTEM

CONTENTS

VQ35DE

<p>BASIC INSPECTION 8</p> <p>DIAGNOSIS AND REPAIR WORKFLOW 8</p> <p style="padding-left: 20px;">Work Flow8</p> <p style="padding-left: 20px;">Diagnostic Work Sheet 11</p> <p>INSPECTION AND ADJUSTMENT12</p> <p>BASIC INSPECTION12</p> <p style="padding-left: 20px;">BASIC INSPECTION : Special Repair Requirement 12</p> <p>ADDITIONAL SERVICE WHEN REPLACING CONTROL UNIT 15</p> <p style="padding-left: 20px;">ADDITIONAL SERVICE WHEN REPLACING CONTROL UNIT : Description 15</p> <p style="padding-left: 20px;">ADDITIONAL SERVICE WHEN REPLACING CONTROL UNIT : Special Repair Requirement 15</p> <p>IDLE SPEED 15</p> <p style="padding-left: 20px;">IDLE SPEED : Description 15</p> <p style="padding-left: 20px;">IDLE SPEED : Special Repair Requirement 15</p> <p>IGNITION TIMING 16</p> <p style="padding-left: 20px;">IGNITION TIMING : Description 16</p> <p style="padding-left: 20px;">IGNITION TIMING : Special Repair Requirement... 16</p> <p>VIN REGISTRATION 16</p> <p style="padding-left: 20px;">VIN REGISTRATION : Description 16</p> <p style="padding-left: 20px;">VIN REGISTRATION : Special Repair Requirement 16</p> <p>ACCELERATOR PEDAL RELEASED POSITION LEARNING 17</p> <p style="padding-left: 20px;">ACCELERATOR PEDAL RELEASED POSITION LEARNING : Description 17</p> <p style="padding-left: 20px;">ACCELERATOR PEDAL RELEASED POSITION LEARNING : Special Repair Requirement 17</p> <p>THROTTLE VALVE CLOSED POSITION LEARNING 17</p>	<p style="padding-left: 20px;">THROTTLE VALVE CLOSED POSITION LEARNING : Description17</p> <p style="padding-left: 20px;">THROTTLE VALVE CLOSED POSITION LEARNING : Special Repair Requirement17</p> <p>IDLE AIR VOLUME LEARNING17</p> <p style="padding-left: 20px;">IDLE AIR VOLUME LEARNING : Description17</p> <p style="padding-left: 20px;">IDLE AIR VOLUME LEARNING : Special Repair Requirement 17</p> <p>MIXTURE RATIO SELF-LEARNING VALUE CLEAR19</p> <p style="padding-left: 20px;">MIXTURE RATIO SELF-LEARNING VALUE CLEAR : Description19</p> <p style="padding-left: 20px;">MIXTURE RATIO SELF-LEARNING VALUE CLEAR : Special Repair Requirement19</p> <p>FUNCTION DIAGNOSIS20</p> <p>ENGINE CONTROL SYSTEM20</p> <p style="padding-left: 20px;">System Diagram20</p> <p style="padding-left: 20px;">System Description21</p> <p style="padding-left: 20px;">Component Parts Location21</p> <p style="padding-left: 20px;">Component Description26</p> <p>MULTIPOINT FUEL INJECTION SYSTEM28</p> <p style="padding-left: 20px;">System Diagram28</p> <p style="padding-left: 20px;">System Description28</p> <p style="padding-left: 20px;">Component Parts Location31</p> <p style="padding-left: 20px;">Component Description36</p> <p>ELECTRIC IGNITION SYSTEM37</p> <p style="padding-left: 20px;">System Diagram37</p> <p style="padding-left: 20px;">System Description37</p> <p style="padding-left: 20px;">Component Parts Location38</p> <p style="padding-left: 20px;">Component Description43</p> <p>AIR CONDITIONING CUT CONTROL44</p> <p style="padding-left: 20px;">System Diagram44</p> <p style="padding-left: 20px;">System Description44</p> <p style="padding-left: 20px;">Component Parts Location45</p> <p style="padding-left: 20px;">Component Description50</p>
--	--

AUTOMATIC SPEED CONTROL DEVICE (ASCD)	51	U0164 CAN COMM CIRCUIT	139
System Diagram	51	Description	139
System Description	51	DTC Logic	139
Component Parts Location	53	Diagnosis Procedure	139
Component Description	58	U1000, U1001 CAN COMM CIRCUIT	140
CAN COMMUNICATION	59	Description	140
System Description	59	DTC Logic	140
COOLING FAN CONTROL	60	Diagnosis Procedure	140
System Diagram	60	P0011, P0021 IVT CONTROL	141
System Description	60	DTC Logic	141
Component Parts Location	62	Diagnosis Procedure	142
Component Description	67	Component Inspection	143
ELECTRONIC CONTROLLED ENGINE MOUNT	68	P0031, P0032, P0051, P0052 A/F SENSOR 1 HEATER	145
System Diagram	68	Description	145
System Description	68	DTC Logic	145
Component Parts Location	71	Diagnosis Procedure	145
Component Description	76	Component Inspection	147
EVAPORATIVE EMISSION SYSTEM	77	P0037, P0038, P0057, P0058 HO2S2 HEATER	148
System Diagram	77	Description	148
System Description	77	DTC Logic	148
Component Parts Location	81	Diagnosis Procedure	149
Component Description	86	Component Inspection	150
INTAKE VALVE TIMING CONTROL	87	P0075, P0081 IVT CONTROL SOLENOID VALVE	151
System Diagram	87	Description	151
System Description	87	DTC Logic	151
Component Parts Location	88	Diagnosis Procedure	151
Component Description	93	Component Inspection	152
VARIABLE INDUCTION AIR SYSTEM	94	P0101 MAF SENSOR	154
System Diagram	94	Description	154
System Description	94	DTC Logic	154
Component Parts Location	96	Component Function Check	157
Component Description	101	Diagnosis Procedure	157
ON BOARD DIAGNOSTIC (OBD) SYSTEM ..	102	Component Inspection	159
Diagnosis Description	102	P0102, P0103 MAF SENSOR	162
CONSULT-III Function	115	Description	162
Diagnosis Tool Function	124	DTC Logic	162
COMPONENT DIAGNOSIS	127	Diagnosis Procedure	163
TROUBLE DIAGNOSIS - SPECIFICATION VALUE	127	Component Inspection	164
Description	127	P0112, P0113 IAT SENSOR	167
Component Function Check	127	Description	167
Diagnosis Procedure	128	DTC Logic	167
POWER SUPPLY AND GROUND CIRCUIT ..	135	Diagnosis Procedure	168
Diagnosis Procedure	135	Component Inspection	168
U0101 CAN COMM CIRCUIT	138	P0116 ECT SENSOR	170
Description	138	Description	170
DTC Logic	138	DTC Logic	170
Diagnosis Procedure	138	Diagnosis Procedure	171
		Component Inspection	171

P0117, P0118 ECT SENSOR	172	Component Function Check	212	A
Description	172	Diagnosis Procedure	213	
DTC Logic	172	Component Inspection	216	
Diagnosis Procedure	173			
Component Inspection	173			
P0122, P0123 TP SENSOR	175	P0139, P0159 HO2S2	219	EC
Description	175	Description	219	
DTC Logic	175	DTC Logic	219	
Diagnosis Procedure	175	Component Function Check	220	C
Component Inspection	177	Diagnosis Procedure	221	
Special Repair Requirement	177	Component Inspection	223	
P0125 ECT SENSOR	178	P0171, P0174 FUEL INJECTION SYSTEM		D
Description	178	FUNCTION	226	
DTC Logic	178	DTC Logic	226	
Diagnosis Procedure	179	Diagnosis Procedure	228	E
Component Inspection	179	P0172, P0175 FUEL INJECTION SYSTEM		F
P0127 IAT SENSOR	181	FUNCTION	231	
Description	181	DTC Logic	231	
DTC Logic	181	Diagnosis Procedure	233	
Diagnosis Procedure	182	P0181 FTT SENSOR	236	G
Component Inspection	182	Description	236	
P0128 THERMOSTAT FUNCTION	183	DTC Logic	236	
DTC Logic	183	Diagnosis Procedure	237	
Diagnosis Procedure	184	Component Inspection	238	H
Component Inspection	185	P0182, P0183 FTT SENSOR	239	I
P0130, P0150 A/F SENSOR 1	186	Description	239	
Description	186	DTC Logic	239	
DTC Logic	186	Diagnosis Procedure	239	
Component Function Check	188	Component Inspection	240	J
Diagnosis Procedure	188	P0196 EOT SENSOR	242	K
P0131, P0151 A/F SENSOR 1	190	Description	242	
Description	190	DTC Logic	242	
DTC Logic	190	Diagnosis Procedure	243	
Diagnosis Procedure	191	Component Inspection	244	L
P0132, P0152 A/F SENSOR 1	194	P0197, P0198 EOT SENSOR	245	M
Description	194	Description	245	
DTC Logic	194	DTC Logic	245	
Diagnosis Procedure	195	Diagnosis Procedure	246	
P0133, P0153 A/F SENSOR 1	198	Component Inspection	246	N
Description	198	P0222, P0223 TP SENSOR	248	
DTC Logic	198	Description	248	
Diagnosis Procedure	200	DTC Logic	248	
P0137, P0157 HO2S2	203	Diagnosis Procedure	248	
Description	203	Component Inspection	250	O
DTC Logic	203	Special Repair Requirement	250	
Component Function Check	204	P0300, P0301, P0302, P0303, P0304, P0305,		P
Diagnosis Procedure	205	P0306 MISFIRE	251	
Component Inspection	207	DTC Logic	251	
P0138, P0158 HO2S2	210	Diagnosis Procedure	252	
Description	210	P0327, P0328, P0332, P0333 KS	257	
DTC Logic	210	Description	257	
		DTC Logic	257	
		Diagnosis Procedure	257	

Component Inspection	258	DTC Logic	300
P0335 CKP SENSOR (POS)	260	Diagnosis Procedure	300
Description	260	Component Inspection	302
DTC Logic	260	P0452 EVAP CONTROL SYSTEM PRES-	303
Diagnosis Procedure	261	SURE SENSOR	303
Component Inspection	263	Description	303
P0340, P0345 CMP SENSOR (PHASE)	264	DTC Logic	303
Description	264	Diagnosis Procedure	304
DTC Logic	264	Component Inspection	306
Diagnosis Procedure	265	P0453 EVAP CONTROL SYSTEM PRES-	308
Component Inspection	266	SURE SENSOR	308
P0420, P0430 THREE WAY CATALYST		Description	308
FUNCTION	268	DTC Logic	308
DTC Logic	268	Diagnosis Procedure	309
Component Function Check	269	Component Inspection	312
Diagnosis Procedure	270	P0455 EVAP CONTROL SYSTEM	314
P0441 EVAP CONTROL SYSTEM	273	DTC Logic	314
DTC Logic	273	Diagnosis Procedure	316
Component Function Check	274	Component Inspection	318
Diagnosis Procedure	275	P0456 EVAP CONTROL SYSTEM	320
P0442 EVAP CONTROL SYSTEM	278	DTC Logic	320
DTC Logic	278	Component Function Check	322
Diagnosis Procedure	279	Diagnosis Procedure	322
Component Inspection	283	Component Inspection	326
P0443 EVAP CANISTER PURGE VOLUME		P0460 FUEL LEVEL SENSOR	327
CONTROL SOLENOID VALVE	284	Description	327
Description	284	DTC Logic	327
DTC Logic	284	Diagnosis Procedure	327
Diagnosis Procedure	285	P0461 FUEL LEVEL SENSOR	329
Component Inspection	287	Description	329
P0444, P0445 EVAP CANISTER PURGE		DTC Logic	329
VOLUME CONTROL SOLENOID VALVE	289	Component Function Check	329
Description	289	Diagnosis Procedure	330
DTC Logic	289	P0462, P0463 FUEL LEVEL SENSOR	331
Diagnosis Procedure	289	Description	331
Component Inspection	291	DTC Logic	331
P0447 EVAP CANISTER VENT CONTROL		Diagnosis Procedure	331
VALVE	292	P0500 VSS	333
Description	292	Description	333
DTC Logic	292	DTC Logic	333
Diagnosis Procedure	292	Component Function Check	334
Component Inspection	294	Diagnosis Procedure	334
P0448 EVAP CANISTER VENT CONTROL		P0506 ISC SYSTEM	335
VALVE	296	Description	335
Description	296	DTC Logic	335
DTC Logic	296	Diagnosis Procedure	335
Diagnosis Procedure	297	P0507 ISC SYSTEM	337
Component Inspection	298	Description	337
P0451 EVAP CONTROL SYSTEM PRES-		DTC Logic	337
SURE SENSOR	300	Diagnosis Procedure	337
Description	300		

P0550 PSP SENSOR	339	Description	365	A
Description	339	DTC Logic	365	
DTC Logic	339	Diagnosis Procedure	365	
Diagnosis Procedure	339	Component Inspection	366	
Component Inspection	340			
P0603 ECM POWER SUPPLY	342	P1551, P1552 BATTERY CURRENT SEN- SOR	368	EC
Description	342	Description	368	
DTC Logic	342	DTC Logic	368	C
Diagnosis Procedure	342	Diagnosis Procedure	368	
		Component Inspection	369	
P0605 ECM	344	P1553 BATTERY CURRENT SENSOR	371	D
Description	344	Description	371	
DTC Logic	344	DTC Logic	371	E
Diagnosis Procedure	345	Diagnosis Procedure	371	
		Component Inspection	372	
P0607 ECM	346	P1554 BATTERY CURRENT SENSOR	374	F
Description	346	Description	374	
DTC Logic	346	DTC Logic	374	G
Diagnosis Procedure	346	Component Function Check	374	
		Diagnosis Procedure	375	
P0643 SENSOR POWER SUPPLY	347	Component Inspection	376	
DTC Logic	347	P1564 ASCD STEERING SWITCH	377	H
Diagnosis Procedure	347	Description	377	
		DTC Logic	377	I
P0850 PNP SWITCH	350	Diagnosis Procedure	377	
Description	350	Component Inspection	379	
DTC Logic	350	P1572 ASCD BRAKE SWITCH	380	J
Component Function Check	351	Description	380	
Diagnosis Procedure	351	DTC Logic	380	
		Diagnosis Procedure	381	
P1148, P1168 CLOSED LOOP CONTROL	353	Component Inspection (ASCD Brake Switch)	384	K
DTC Logic	353	Component Inspection (Stop Lamp Switch)	384	
		P1574 ASCD VEHICLE SPEED SENSOR	386	L
P1212 TCS COMMUNICATION LINE	354	Description	386	
Description	354	DTC Logic	386	M
DTC Logic	354	Diagnosis Procedure	386	
Diagnosis Procedure	354	P1700 CVT CONTROL SYSTEM	388	
		Description	388	
P1217 ENGINE OVER TEMPERATURE	355	P1715 INPUT SPEED SENSOR (PRIMARY SPEED SENSOR)	389	N
DTC Logic	355	Description	389	
Component Function Check	355	DTC Logic	389	O
Diagnosis Procedure	356	Diagnosis Procedure	389	
		P1720 VSS	391	P
P1225 TP SENSOR	359	Description	391	
Description	359	DTC Logic	391	
DTC Logic	359	Diagnosis Procedure	391	
Diagnosis Procedure	359	P1800 VIAS CONTROL SOLENOID VALVE 1.	393	
Special Repair Requirement	360	Description	393	
		DTC Logic	393	
P1226 TP SENSOR	361	Diagnosis Procedure	393	
Description	361			
DTC Logic	361			
Diagnosis Procedure	361			
Special Repair Requirement	362			
P1421 COLD START CONTROL	363			
Description	363			
DTC Logic	363			
Diagnosis Procedure	363			
P1550 BATTERY CURRENT SENSOR	365			

Component Inspection	394	Special Repair Requirement	422
P1801 VIAS CONTROL SOLENOID VALVE 2	396	P2138 APP SENSOR	423
Description	396	Description	423
DTC Logic	396	DTC Logic	423
Diagnosis Procedure	396	Diagnosis Procedure	424
Component Inspection	397	Component Inspection	426
Special Repair Requirement		Special Repair Requirement	426
P1805 BRAKE SWITCH	399	P2A00, P2A03 A/F SENSOR 1	427
Description	399	Description	427
DTC Logic	399	DTC Logic	427
Diagnosis Procedure	399	Diagnosis Procedure	428
Component Inspection (Stop Lamp Switch)	401	ASC D BRAKE SWITCH	431
P2100, P2103 THROTTLE CONTROL MOTOR RELAY	402	Description	431
Description	402	Component Function Check	431
DTC Logic	402	Diagnosis Procedure	431
Diagnosis Procedure	402	Component Inspection (ASC D Brake Switch)	432
P2101 ELECTRIC THROTTLE CONTROL FUNCTION	404	ASC D INDICATOR	433
Description	404	Description	433
DTC Logic	404	Component Function Check	433
Diagnosis Procedure	404	Diagnosis Procedure	433
Component Inspection	406	COOLING FAN	434
Special Repair Requirement	407	Description	434
P2118 THROTTLE CONTROL MOTOR	408	Component Function Check	434
Description	408	Diagnosis Procedure	434
DTC Logic	408	Component Inspection (Cooling Fan Motor)	437
Diagnosis Procedure	408	Component Inspection (Cooling Fan Relay)	438
Component Inspection	409	ELECTRICAL LOAD SIGNAL	439
Special Repair Requirement	409	Description	439
P2119 ELECTRIC THROTTLE CONTROL ACTUATOR	411	Component Function Check	439
Description	411	Diagnosis Procedure	439
DTC Logic	411	ELECTRONIC CONTROLLED ENGINE MOUNT	441
Diagnosis Procedure	412	Description	441
Special Repair Requirement	412	Component Function Check	441
P2122, P2123 APP SENSOR	413	Diagnosis Procedure	441
Description	413	Component Inspection	442
DTC Logic	413	FUEL INJECTOR	444
Diagnosis Procedure	413	Description	444
Component Inspection	415	Component Function Check	444
Special Repair Requirement	415	Diagnosis Procedure	444
P2127, P2128 APP SENSOR	416	Component Inspection	446
Description	416	FUEL PUMP	447
DTC Logic	416	Description	447
Diagnosis Procedure	416	Component Function Check	447
Component Inspection	418	Diagnosis Procedure	447
Special Repair Requirement	419	Component Inspection (Fuel Pump)	450
P2135 TP SENSOR	420	Component Inspection (Condenser)	450
Description	420	IGNITION SIGNAL	451
DTC Logic	420	Description	451
Diagnosis Procedure	420	Component Function Check	451
Component Inspection	422	Diagnosis Procedure	451

Component Inspection (Ignition Coil with Power Transistor)	454	NORMAL OPERATING CONDITION	537	
Component Inspection (Condenser)	455	Description	537	A
MALFUNCTION INDICATOR LAMP	456	PRECAUTION	538	
Description	456	PRECAUTIONS	538	EC
Component Function Check	456	Precaution for Supplemental Restraint System (SRS) "AIR BAG" and "SEAT BELT PRE-TENSIONER"	538	C
Diagnosis Procedure	456	Precautions For Xenon Headlamp Service	538	D
ON BOARD REFUELING VAPOR RECOVERY (ORVR)	457	Precaution for Procedure without Cowl Top Cover	538	
Description	457	On Board Diagnostic (OBD) System of Engine and CVT	539	D
Component Function Check	457	General Precautions	539	E
Diagnosis Procedure	457	PREPARATION	543	E
Component Inspection	460	PREPARATION	543	
POSITIVE CRANKCASE VENTILATION	462	Special Service Tools	543	F
Description	462	Commercial Service Tools	543	
Component Inspection	462	ON-VEHICLE MAINTENANCE	545	G
REFRIGERANT PRESSURE SENSOR	463	FUEL PRESSURE	545	
Description	463	Inspection	545	H
Component Function Check	463	EVAP LEAK CHECK	547	
Diagnosis Procedure	463	Inspection	547	H
VARIABLE INDUCTION AIR SYSTEM	466	ON-VEHICLE REPAIR	549	I
Description	466	EVAP CANISTER	549	
Component Function Check	466	Exploded View	549	J
Diagnosis Procedure	467	Removal and Installation	549	
ECU DIAGNOSIS	470	Inspection	550	J
ECM	470	SERVICE DATA AND SPECIFICATIONS (SDS)	551	K
Reference Value	470	SERVICE DATA AND SPECIFICATIONS (SDS)	551	
Wiring Diagram—ENGINE CONTROL SYSTEM—		Idle Speed	551	L
TEM—	484	Ignition Timing	551	
Fail-safe	517	Calculated Load Value	551	M
DTC Inspection Priority Chart	519	Mass Air Flow Sensor	551	
DTC Index	521			N
How to Set SRT Code	524			O
Test Value and Test Limit	526			P
SYMPTOM DIAGNOSIS	533			
ENGINE CONTROL SYSTEM SYMPTOMS ...	533			
Symptom Table	533			

DIAGNOSIS AND REPAIR WORKFLOW

< BASIC INSPECTION >

[VQ35DE]

BASIC INSPECTION

DIAGNOSIS AND REPAIR WORKFLOW

Work Flow

INFOID:000000003387866

OVERALL SEQUENCE

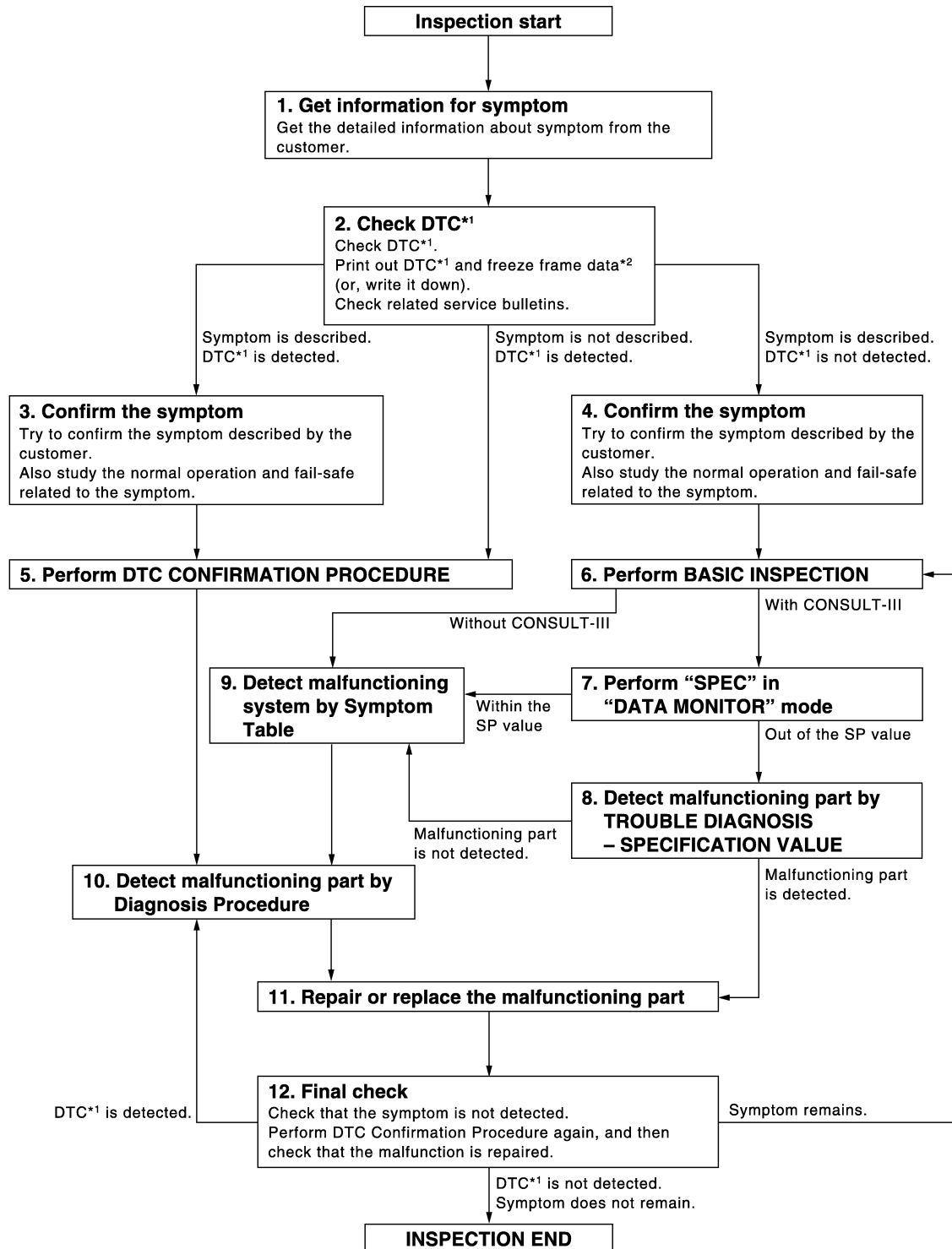

*1: Include 1st trip DTC.

*2: Include 1st trip freeze frame data.

JMBIA1416GB

DETAILED FLOW

DIAGNOSIS AND REPAIR WORKFLOW

< BASIC INSPECTION >

[VQ35DE]

1.GET INFORMATION FOR SYMPTOM

Get the detailed information from the customer about the symptom (the condition and the environment when the incident/malfunction occurred) using the "Diagnostic Work Sheet". (Refer to [EC-11, "Diagnostic Work Sheet"](#).)

>> GO TO 2.

2.CHECK DTC

1. Check DTC.
2. Perform the following procedure if DTC is displayed.
 - Record DTC and freeze frame data. (Print them out with CONSULT-III or GST.)
 - Erase DTC. (Refer to [EC-102, "Diagnosis Description"](#).)
 - Study the relationship between the cause detected by DTC and the symptom described by the customer. (Symptom Table is useful. Refer to [EC-533, "Symptom Table"](#).)
3. Check related service bulletins for information.

Is any symptom described and any DTC detected?

Symptom is described, DTC is displayed>>GO TO 3.

Symptom is described, DTC is not displayed>>GO TO 4.

Symptom is not described, DTC is displayed>>GO TO 5.

3.CONFIRM THE SYMPTOM

Try to confirm the symptom described by the customer (except MIL ON).

Also study the normal operation and fail safe related to the symptom. Refer to [EC-537, "Description"](#) and [EC-517, "Fail-safe"](#).

Diagnosis Work Sheet is useful to verify the incident.

Verify relation between the symptom and the condition when the symptom is detected.

>> GO TO 5.

4.CONFIRM THE SYMPTOM

Try to confirm the symptom described by the customer.

Also study the normal operation and fail safe related to the symptom. Refer to [EC-537, "Description"](#) and [EC-517, "Fail-safe"](#).

Diagnosis Work Sheet is useful to verify the incident.

Verify relation between the symptom and the condition when the symptom is detected.

>> GO TO 6.

5.PERFORM DTC CONFIRMATION PROCEDURE

Perform DTC CONFIRMATION PROCEDURE for the displayed DTC, and then check that DTC is detected again.

If two or more DTCs are detected, refer to [EC-519, "DTC Inspection Priority Chart"](#) and determine trouble diagnosis order.

NOTE:

- Freeze frame data is useful if the DTC is not detected.
- Perform Component Function Check if DTC CONFIRMATION PROCEDURE is not included on Service Manual. This simplified check procedure is an effective alternative though DTC cannot be detected during this check.
If the result of Component Function Check is NG, it is the same as the detection of DTC by DTC CONFIRMATION PROCEDURE.

Is DTC detected?

YES >> GO TO 10.

NO >> Check according to [GI-40, "Intermittent Incident"](#).

6.PERFORM BASIC INSPECTION

Perform [EC-12, "BASIC INSPECTION : Special Repair Requirement"](#).

Will CONSULT-III be used?

DIAGNOSIS AND REPAIR WORKFLOW

[VQ35DE]

< BASIC INSPECTION >

- YES >> GO TO 7.
NO >> GO TO 9.

7. PERFORM "SPEC" OF "DATA MONITOR" MODE

Ⓜ With CONSULT-III

Check that "MAS A/F SE-B1", "B/FUEL SCHDL", "A/F ALPHA-B1" and "A/F ALPHA-B2" are within the SP value using "SPEC" of "DATA MONITOR" mode with CONSULT-III. Refer to [EC-127, "Component Function Check"](#).

Are they within the SP value?

- YES >> GO TO 9.
NO >> GO TO 8.

8. DETECT MALFUNCTIONING PART BY TROUBLE DIAGNOSIS - SPECIFICATION VALUE

Detect malfunctioning part according to [EC-128, "Diagnosis Procedure"](#).

Is malfunctioning part detected?

- YES >> GO TO 11.
NO >> GO TO 9.

9. DETECT MALFUNCTIONING SYSTEM BY SYMPTOM TABLE

Detect malfunctioning system according to [EC-533, "Symptom Table"](#) based on the confirmed symptom in step 4, and determine the trouble diagnosis order based on possible causes and symptom.

>> GO TO 10.

10. DETECT MALFUNCTIONING PART BY DIAGNOSTIC PROCEDURE

Inspect according to Diagnostic Procedure of the system.

NOTE:

The Diagnostic Procedure in EC section described based on open circuit inspection. A short circuit inspection is also required for the circuit check in the Diagnostic Procedure. For details, refer to "Circuit Inspection" in [GI-43, "Circuit Inspection"](#).

Is malfunctioning part detected?

- YES >> GO TO 11.
NO >> Monitor input data from related sensors or check voltage of related ECM terminals using CONSULT-III. Refer to [EC-470, "Reference Value"](#).

11. REPAIR OR REPLACE THE MALFUNCTIONING PART

1. Repair or replace the malfunctioning part.
2. Reconnect parts or connectors disconnected during Diagnostic Procedure again after repair and replacement.
3. Check DTC. If DTC is displayed, erase it, refer to [EC-102, "Diagnosis Description"](#).

>> GO TO 12.

12. FINAL CHECK

When DTC was detected in step 2, perform DTC CONFIRMATION PROCEDURE or Component Function Check again, and then check that the malfunction have been repaired securely.

When symptom was described from the customer, refer to confirmed symptom in step 3 or 4, and check that the symptom is not detected.

Is DTC detected and does symptom remain?

- YES-1 >> DTC is detected: GO TO 10.
YES-2 >> Symptom remains: GO TO 6.
NO >> Before returning the vehicle to the customer, erase unnecessary DTC in ECM and TCM (Transmission Control Module) certainly. (Refer to [EC-102, "Diagnosis Description"](#).) If the completion of SRT is needed, drive vehicle under the specific DRIVING PATTERN in [EC-524, "How to Set SRT Code"](#).

INSPECTION AND ADJUSTMENT

BASIC INSPECTION

BASIC INSPECTION : Special Repair Requirement

INFOID:000000003387868

1.INSPECTION START

1. Check service records for any recent repairs that may indicate a related malfunction, or a current need for scheduled maintenance.
2. Open engine hood and check the following:
 - Harness connectors for improper connections
 - Wiring harness for improper connections, pinches and cut
 - Vacuum hoses for splits, kinks and improper connections
 - Hoses and ducts for leakage
 - Air cleaner clogging
 - Gasket
3. Check that electrical or mechanical loads are not applied.
 - Head lamp switch is OFF.
 - Air conditioner switch is OFF.
 - Rear window defogger switch is OFF.
 - Steering wheel is in the straight-ahead position, etc.
4. Start engine and warm it up until engine coolant temperature indicator points to the middle of gauge.
Check that engine stays below 1,000 rpm.

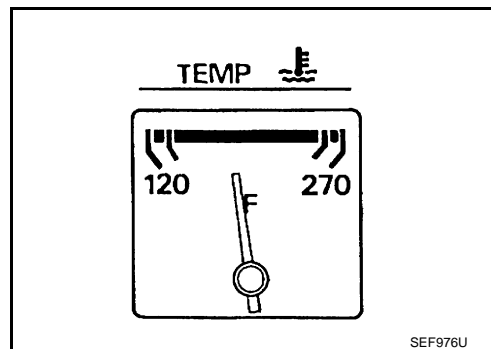
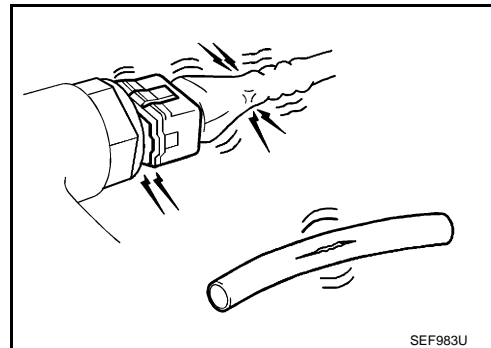

5. Run engine at approximately 2,000 rpm for approximately 2 minutes under no load.
6. Check that no DTC is displayed with CONSULT-III or GST.

Are any DTCs detected?

- YES >> GO TO 2.
NO >> GO TO 3.

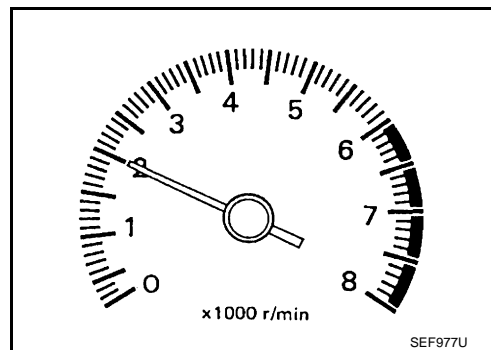

2.REPAIR OR REPLACE

Repair or replace components as necessary according to corresponding Diagnostic Procedure.

>> GO TO 3

3.CHECK TARGET IDLE SPEED

1. Run engine at approximately 2,000 rpm for approximately 2 minutes under no load.

INSPECTION AND ADJUSTMENT

[VQ35DE]

< BASIC INSPECTION >

- Rev engine (2,000 to 3,000 rpm) 2 or 3 times under no load, then run engine at idle speed for approximately 1 minute.
- Check idle speed.
For procedure, refer to [EC-15, "IDLE SPEED : Special Repair Requirement"](#).
For specification, refer to [EC-551, "Idle Speed"](#).

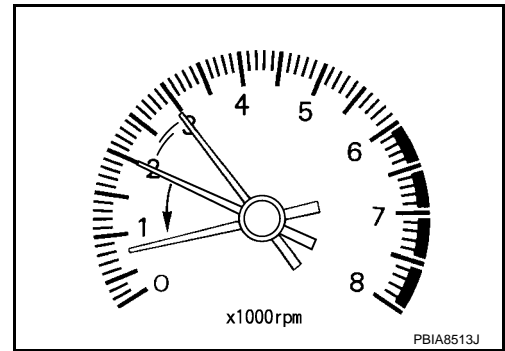

Is the inspection result normal?

- YES >> GO TO 10.
NO >> GO TO 4.

4.PERFORM ACCELERATOR PEDAL RELEASED POSITION LEARNING

- Stop engine.
- Perform [EC-17, "ACCELERATOR PEDAL RELEASED POSITION LEARNING : Special Repair Requirement"](#).

>> GO TO 5.

5.PERFORM THROTTLE VALVE CLOSED POSITION LEARNING

Perform [EC-17, "THROTTLE VALVE CLOSED POSITION LEARNING : Special Repair Requirement"](#).

>> GO TO 6.

6.PERFORM IDLE AIR VOLUME LEARNING

Perform [EC-17, "IDLE AIR VOLUME LEARNING : Special Repair Requirement"](#).

Is Idle Air Volume Learning carried out successfully?

- YES >> GO TO 7.
NO >> Follow the instruction of Idle Air Volume Learning. Then GO TO 4.

7.CHECK IDLE SPEED AGAIN

- Start engine and warm it up to normal operating temperature.
- Check idle speed.
For procedure, refer to [EC-15, "IDLE SPEED : Special Repair Requirement"](#).
For specification, refer to [EC-551, "Idle Speed"](#).

Is the inspection result normal?

- YES >> GO TO 10.
NO >> GO TO 8.

8.DETECT MALFUNCTIONING PART

Check the Following.

- Check camshaft position sensor (PHASE) and circuit. Refer to [EC-265, "Diagnosis Procedure"](#).
- Check crankshaft position sensor (POS) and circuit. Refer to [EC-261, "Diagnosis Procedure"](#).

Is the inspection result normal?

- YES >> GO TO 9.
NO >> Repair or replace malfunctioning part. Then GO TO 4.

9.CHECK ECM FUNCTION

- Substitute with a non-malfunctioning ECM to check ECM function. (ECM may be the cause of the incident, although this is rare.)
- Perform initialization of NVIS (NATS) system and registration of all NVIS (NATS) ignition key IDs. Refer to [SEC-11, "ECM RECOMMUNICATING FUNCTION : Special Repair Requirement"](#).

>> GO TO 4.

10.CHECK IGNITION TIMING

- Run engine at idle.
- Check ignition timing with a timing light.

INSPECTION AND ADJUSTMENT

[VQ35DE]

< BASIC INSPECTION >

For procedure, refer to [EC-16, "IGNITION TIMING : Special Repair Requirement"](#).

For specification, refer to [EC-551, "Ignition Timing"](#).

Is the inspection result normal?

YES >> GO TO 19.

NO >> GO TO 11.

11.PERFORM ACCELERATOR PEDAL RELEASED POSITION LEARNING

1. Stop engine.

2. Perform [EC-17, "ACCELERATOR PEDAL RELEASED POSITION LEARNING : Special Repair Requirement"](#).

>> GO TO 12.

12.PERFORM THROTTLE VALVE CLOSED POSITION LEARNING

Perform [EC-17, "THROTTLE VALVE CLOSED POSITION LEARNING : Special Repair Requirement"](#).

>> GO TO 13.

13.PERFORM IDLE AIR VOLUME LEARNING

Perform [EC-17, "IDLE AIR VOLUME LEARNING : Special Repair Requirement"](#).

Is Idle Air Volume Learning carried out successfully?

YES >> GO TO 14.

NO >> Follow the instruction of Idle Air Volume Learning. Then GO TO 4.

14.CHECK IDLE SPEED AGAIN

1. Start engine and warm it up to normal operating temperature.

2. Check idle speed.

For procedure, refer to [EC-15, "IDLE SPEED : Special Repair Requirement"](#).

For specification, refer to [EC-551, "Idle Speed"](#).

Is the inspection result normal?

YES >> GO TO 15.

NO >> GO TO 17.

15.CHECK IGNITION TIMING AGAIN

1. Run engine at idle.

2. Check ignition timing with a timing light.

For procedure, refer to [EC-16, "IGNITION TIMING : Special Repair Requirement"](#).

For specification, refer to [EC-551, "Ignition Timing"](#).

Is the inspection result normal?

YES >> GO TO 19.

NO >> GO TO 16.

16.CHECK TIMING CHAIN INSTALLATION

Check timing chain installation. Refer to [EM-54, "Removal and Installation"](#).

Is the inspection result normal?

YES >> GO TO 17.

NO >> Repair the timing chain installation. Then GO TO 4.

17.DETECT MALFUNCTIONING PART

Check the following.

• Check camshaft position sensor (PHASE) and circuit. Refer to [EC-265, "Diagnosis Procedure"](#).

• Check crankshaft position sensor (POS) and circuit. Refer to [EC-261, "Diagnosis Procedure"](#).

Is the inspection result normal?

YES >> GO TO 18.

NO >> Repair or replace malfunctioning part. Then GO TO 4.

18.CHECK ECM FUNCTION

INSPECTION AND ADJUSTMENT

[VQ35DE]

< BASIC INSPECTION >

1. Substitute with a non-malfunctioning ECM to check ECM function. (ECM may be the cause of the incident, although this is rare.)
2. Perform initialization of NVIS (NATS) system and registration of all NVIS (NATS) ignition key IDs. Refer to [EC-15. "ADDITIONAL SERVICE WHEN REPLACING CONTROL UNIT : Special Repair Requirement"](#).

>> GO TO 4.

19.INSPECTION END

If ECM is replaced during this BASIC INSPECTION procedure, perform [EC-15. "ADDITIONAL SERVICE WHEN REPLACING CONTROL UNIT : Special Repair Requirement"](#).

>> INSPECTION END

ADDITIONAL SERVICE WHEN REPLACING CONTROL UNIT

ADDITIONAL SERVICE WHEN REPLACING CONTROL UNIT : Description

INFOID:000000003387869

When replacing ECM, the following procedure must be performed.

ADDITIONAL SERVICE WHEN REPLACING CONTROL UNIT : Special Repair Requirement

INFOID:000000003387870

1.PERFORM INITIALIZATION OF NVIS (NATS) SYSTEM AND REGISTRATION OF ALL NVIS (NATS) IGNITION KEY IDS

Refer to [SEC-11. "ECM RECOMMUNICATING FUNCTION : Special Repair Requirement"](#).

>> GO TO 2.

2.PERFORM VIN REGISTRATION

Refer to [EC-16. "VIN REGISTRATION : Special Repair Requirement"](#).

>> GO TO 3.

3.PERFORM ACCELERATOR PEDAL RELEASED POSITION LEARNING

Refer to [EC-17. "ACCELERATOR PEDAL RELEASED POSITION LEARNING : Special Repair Requirement"](#).

>> GO TO 4.

4.PERFORM THROTTLE VALVE CLOSED POSITION LEARNING

Refer to [EC-17. "THROTTLE VALVE CLOSED POSITION LEARNING : Special Repair Requirement"](#).

>> GO TO 5.

5.PERFORM IDLE AIR VOLUME LEARNING

Refer to [EC-17. "IDLE AIR VOLUME LEARNING : Special Repair Requirement"](#).

>> END

IDLE SPEED

IDLE SPEED : Description

INFOID:000000003387871

This describes how to check the idle speed. For the actual procedure, follow the instructions in "BASIC INSPECTION".

IDLE SPEED : Special Repair Requirement

INFOID:000000003387872

1.CHECK IDLE SPEED

< BASIC INSPECTION >

With CONSULT-III

Check idle speed in "DATA MONITOR" mode with CONSULT-III.

With GST

Check idle speed with Service \$01 of GST.

>> INSPECTION END

IGNITION TIMING

IGNITION TIMING : Description

INFOID:000000003387873

This describes how to check the ignition timing. For the actual procedure, follow the instructions in "BASIC INSPECTION".

IGNITION TIMING : Special Repair Requirement

INFOID:000000003387874

1. CHECK IGNITION TIMING

1. Attach timing light to loop wires as shown.
 - Timing light (A)
 - ↶: Vehicle front

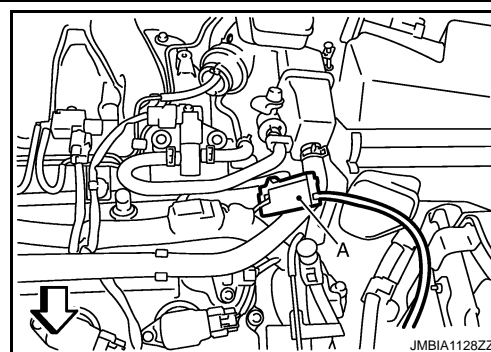

2. Check ignition timing.

>> INSPECTION END

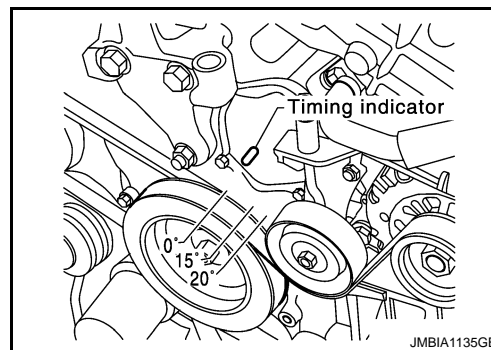

VIN REGISTRATION

VIN REGISTRATION : Description

INFOID:000000003387875

VIN Registration is an operation to register VIN in ECM. It must be performed each time ECM is replaced.

NOTE:

Accurate VIN which is registered in ECM may be required for Inspection & Maintenance (I/M).

VIN REGISTRATION : Special Repair Requirement

INFOID:000000003387876

1. CHECK VIN

Check the VIN of the vehicle and note it. Refer to [GI-23. "Information About Identification or Model Code"](#).

>> GO TO 2.

2. PERFORM VIN REGISTRATION

With CONSULT-III

1. Turn ignition switch ON with engine stopped.

2. Select "VIN REGISTRATION" in "WORK SUPPORT" mode.
3. Follow the instructions on the CONSULT-III display.

A

>> END

ACCELERATOR PEDAL RELEASED POSITION LEARNING

EC

ACCELERATOR PEDAL RELEASED POSITION LEARNING : Description INFOID:000000003387877

Accelerator Pedal Released Position Learning is a function of ECM to learn the fully released position of the accelerator pedal by monitoring the accelerator pedal position sensor output signal. It must be performed each time the harness connector of the accelerator pedal position sensor or ECM is disconnected.

C

ACCELERATOR PEDAL RELEASED POSITION LEARNING : Special Repair Requirement INFOID:000000003387878

D

1. START

E

1. Check that accelerator pedal is fully released.
2. Turn ignition switch ON and wait at least 2 seconds.
3. Turn ignition switch OFF and wait at least 10 seconds.
4. Turn ignition switch ON and wait at least 2 seconds.
5. Turn ignition switch OFF and wait at least 10 seconds.

F

G

>> END

THROTTLE VALVE CLOSED POSITION LEARNING

H

THROTTLE VALVE CLOSED POSITION LEARNING : Description INFOID:000000003387879

Throttle Valve Closed Position Learning is a function of ECM to learn the fully closed position of the throttle valve by monitoring the throttle position sensor output signal. It must be performed each time the harness connector of electric throttle control actuator or ECM is disconnected.

I

THROTTLE VALVE CLOSED POSITION LEARNING : Special Repair Requirement INFOID:000000003387880

J

1. START

K

1. Check that accelerator pedal is fully released.
2. Turn ignition switch ON.
3. Turn ignition switch OFF and wait at least 10 seconds.
Check that throttle valve moves during the above 10 seconds by confirming the operating sound.

L

M

>> END

IDLE AIR VOLUME LEARNING

N

IDLE AIR VOLUME LEARNING : Description INFOID:000000003387881

Idle Air Volume Learning is a function of ECM to learn the idle air volume that keeps engine idle speed within the specific range. It must be performed under the following conditions:

O

- Each time the electric throttle control actuator or ECM is replaced.
- Idle speed or ignition timing is out of the specification.

IDLE AIR VOLUME LEARNING : Special Repair Requirement INFOID:000000003387882

P

1. PRECONDITIONING

Check that all of the following conditions are satisfied.
Learning will be cancelled if any of the following conditions are missed for even a moment.

- Battery voltage: More than 12.9 V (At idle)
- Engine coolant temperature: 70 - 100°C (158 - 212°F)
- Selector lever position: P or N

INSPECTION AND ADJUSTMENT

[VQ35DE]

< BASIC INSPECTION >

- Electric load switch: OFF
(Air conditioner, head lamp, rear window defogger)
On vehicles equipped with daytime light systems, if the parking brake is applied before the engine is started the head lamp will not illuminate.
- Steering wheel: Neutral (Straight-ahead position)
- Vehicle speed: Stopped
- Transmission: Warmed-up
- With CONSULT-III: Drive vehicle until "ATF TEMP SEN" in "DATA MONITOR" mode of "CVT" system indicates less than 0.9 V.
- Without CONSULT-III: Drive vehicle for 10 minutes.

Will CONSULT-III be used?

- YES >> GO TO 2.
- NO >> GO TO 3.

2.PERFORM IDLE AIR VOLUME LEARNING

④ With CONSULT-III

1. Perform [EC-17, "ACCELERATOR PEDAL RELEASED POSITION LEARNING : Special Repair Requirement"](#).
2. Perform [EC-17, "THROTTLE VALVE CLOSED POSITION LEARNING : Special Repair Requirement"](#).
3. Start engine and warm it up to normal operating temperature.
4. Select "IDLE AIR VOL LEARN" in "WORK SUPPORT" mode.
5. Touch "START" and wait 20 seconds.

Is "CMPLT" displayed on CONSULT-III screen?

- YES >> GO TO 4.
- NO >> GO TO 5.

3.PERFORM IDLE AIR VOLUME LEARNING

⊗ Without CONSULT-III

NOTE:

- It is better to count the time accurately with a clock.
 - It is impossible to switch the diagnostic mode when an accelerator pedal position sensor circuit has a malfunction.
1. Perform [EC-17, "ACCELERATOR PEDAL RELEASED POSITION LEARNING : Special Repair Requirement"](#).
 2. Perform [EC-17, "THROTTLE VALVE CLOSED POSITION LEARNING : Special Repair Requirement"](#).
 3. Start engine and warm it up to normal operating temperature.
 4. Turn ignition switch OFF and wait at least 10 seconds.
 5. Confirm that accelerator pedal is fully released, turn ignition switch ON and wait 3 seconds.
 6. Repeat the following procedure quickly 5 times within 5 seconds.
 - Fully depress the accelerator pedal.
 - Fully release the accelerator pedal.
 7. Wait 7 seconds, fully depress the accelerator pedal for approx. 20 seconds until the MIL stops blinking and turns ON.
 8. Fully release the accelerator pedal within 3 seconds after the MIL turns ON.
 9. Start engine and let it idle.
 10. Wait 20 seconds.

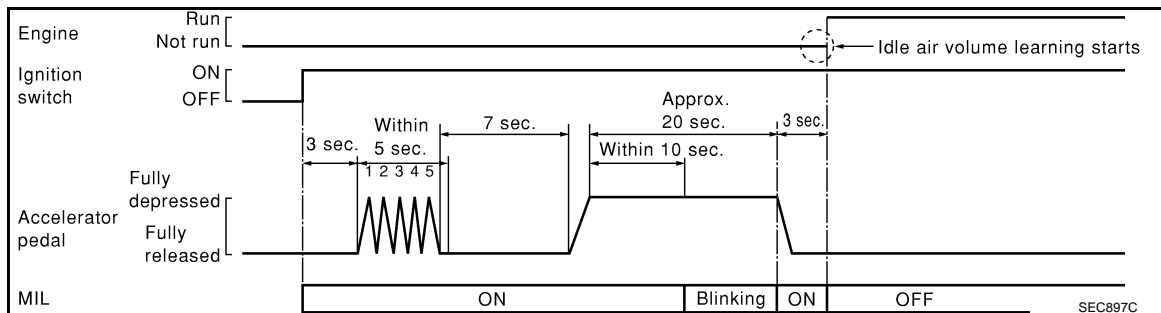

>> GO TO 4.

4. CHECK IDLE SPEED AND IGNITION TIMING

Rev up the engine 2 or 3 times and check that idle speed and ignition timing are within the specifications. For procedure, refer to [EC-15, "IDLE SPEED : Special Repair Requirement"](#) and [EC-16, "IGNITION TIMING : Special Repair Requirement"](#).

For specifications, refer to [EC-551, "Idle Speed"](#) and [EC-551, "Ignition Timing"](#).

Is the inspection result normal?

- YES >> INSPECTION END
- NO >> GO TO 5.

5. DETECT MALFUNCTIONING PART-I

Check the following

- Check that throttle valve is fully closed.
- Check PCV valve operation.
- Check that downstream of throttle valve is free from air leakage.

Is the inspection result normal?

- YES >> GO TO 6.
- NO >> Repair or replace malfunctioning part.

6. DETECT MALFUNCTIONING PART-II

Engine component parts and their installation condition are questionable. Check and eliminate the cause of the incident.

It is useful to perform "TROUBLE DIAGNOSIS - SPECIFICATION VALUE". Refer to [EC-127, "Description"](#).

If any of the following conditions occur after the engine has started, eliminate the cause of the incident and perform Idle Air Volume Learning again:

- Engine stalls.
- Incorrect idle.

>> INSPECTION END

MIXTURE RATIO SELF-LEARNING VALUE CLEAR

MIXTURE RATIO SELF-LEARNING VALUE CLEAR : Description

INFOID:000000003387883

This describes show to erase the mixture ratio self-learning value. For the actual procedure, follow the instructions in "Diagnosis Procedure".

MIXTURE RATIO SELF-LEARNING VALUE CLEAR : Special Repair Requirement

INFOID:000000003387884

1. START

With CONSULT-III

1. Start engine and warm it up to normal operating temperature.
2. Select "SELF-LEARNING CONT" in "WORK SUPPORT" mode with CONSULT-III.
3. Clear mixture ratio self-learning value by touching "CLEAR".

With GST

1. Start engine and warm it up to normal operating temperature.
2. Turn ignition switch OFF.
3. Disconnect mass air flow sensor harness connector.
4. Restart engine and let it idle for at least 5 seconds.
5. Stop engine and reconnect mass air flow sensor harness connector.
6. Select Service \$03 with GST. Check that DTC P0102 is detected.
7. Select Service \$04 with GST to erase the DTC P0102.

>> END

ENGINE CONTROL SYSTEM

[VQ35DE]

< FUNCTION DIAGNOSIS >

System Description

INFOID:000000003387886

ECM performs various controls such as fuel injection control and ignition timing control.

Component Parts Location

INFOID:000000003387887

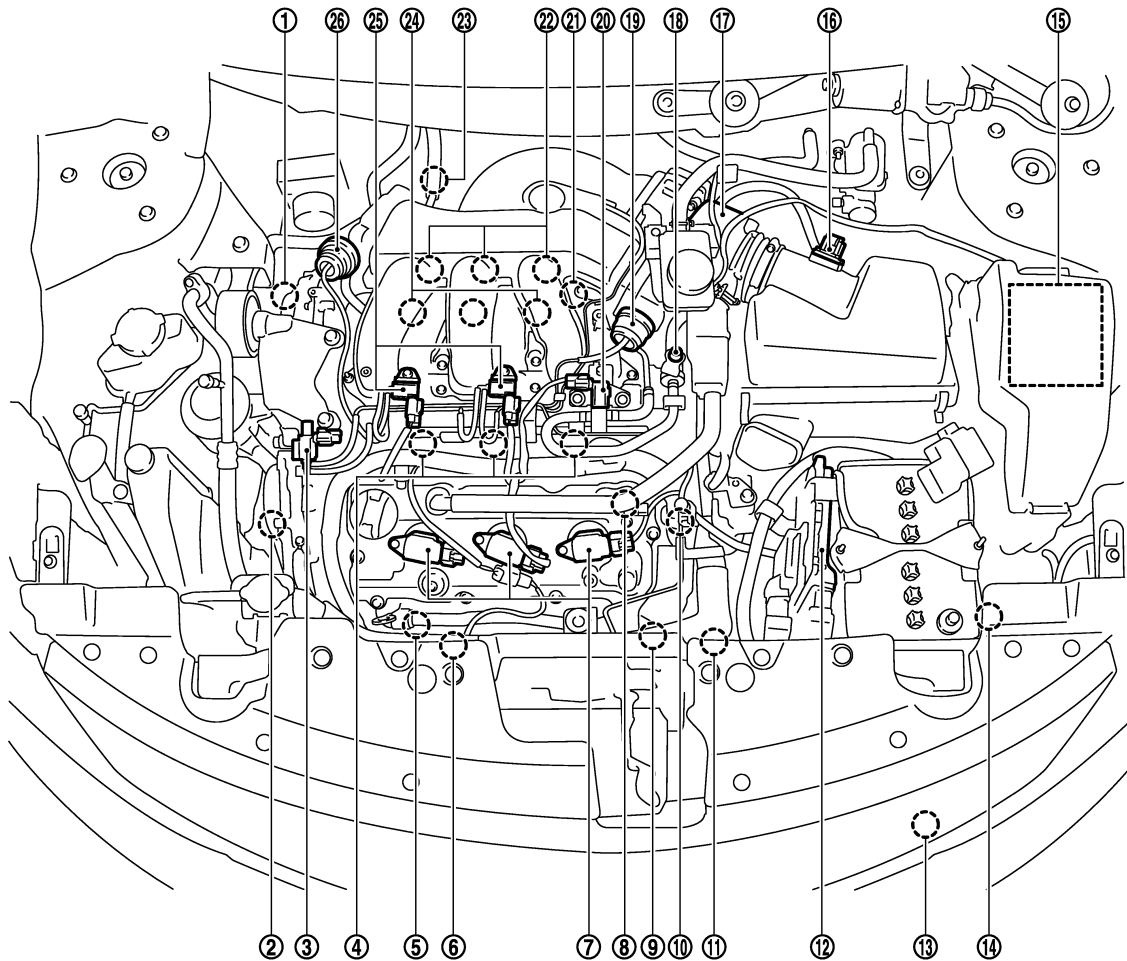

JMBIA1108ZZ

- | | | |
|---|--|--|
| 1. Intake valve timing control solenoid valve (bank 1) | 2. Intake valve timing control solenoid valve (bank 2) | 3. Electronic controlled engine mount control solenoid valve |
| 4. Fuel injector (bank 2) | 5. A/F sensor 1 (bank 2) | 6. Cooling fan motor-2 |
| 7. Ignition coil (with power transistor) and spark plug (bank 2) | 8. Camshaft position sensor (PHASE) (bank 2) | 9. Crankshaft position sensor (POS) |
| 10. Engine coolant temperature sensor | 11. Cooling fan motor-1 | 12. ECM |
| 13. Refrigerant pressure sensor | 14. Battery current sensor | 15. IPDM E/R |
| 16. Mass air flow sensor (with intake air temperature sensor) | 17. Electric throttle control actuator | 18. EVAP service port |
| 19. Power valve actuator 2 | 20. EVAP canister purge volume control solenoid valve | 21. Camshaft position sensor (PHASE) (bank 1) |
| 22. Ignition coil (with power transistor) and spark plug (bank 1) | 23. A/F sensor 1 (bank 1) | 24. Fuel injector (bank 1) |
| 25. VIAS control solenoid valve 1 and 2 | 26. Power valve actuator 1 | |

ENGINE CONTROL SYSTEM

< FUNCTION DIAGNOSIS >

[VQ35DE]

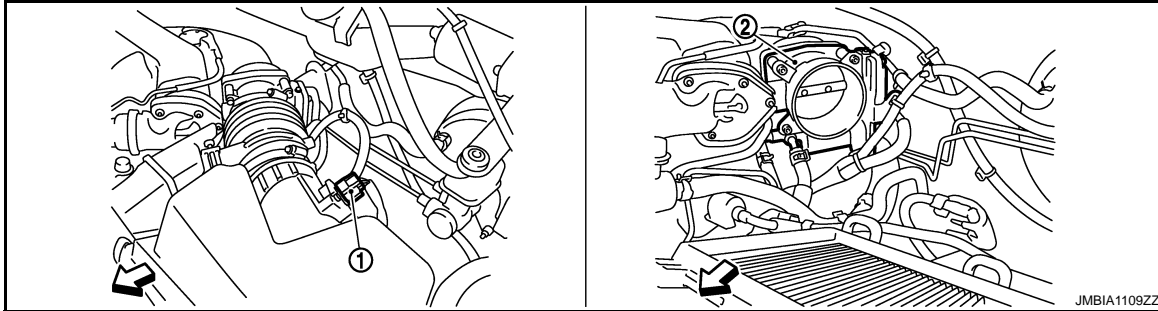

- 1. Mas air flow sensor (with intake air temperature sensor)
- 2. Electric throttle control actuator

← : Vehicle front

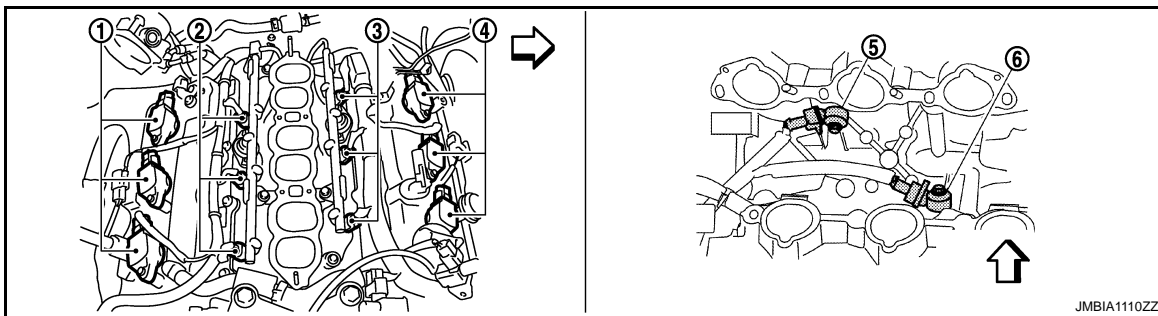

- 1. Ignition coil (with power transistor and spark plug (bank 1))
- 2. Fuel injector (bank 1)
- 3. Fuel injector (bank 2)
- 4. Ignition coil (with power transistor and spark plug (bank 2))
- 5. Knock sensor (bank 2)
- 6. Knock sensor (bank 1)

← : Vehicle front

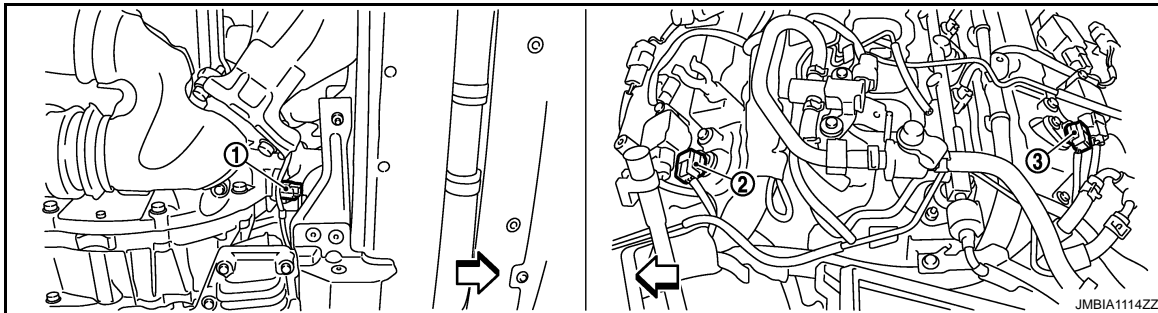

- 1. Crankshaft position sensor (POS)
- 2. Camshaft position sensor (PHASE) (bank 1)
- 3. Camshaft position sensor (PHASE) (bank 2)

← : Vehicle front

ENGINE CONTROL SYSTEM

< FUNCTION DIAGNOSIS >

[VQ35DE]

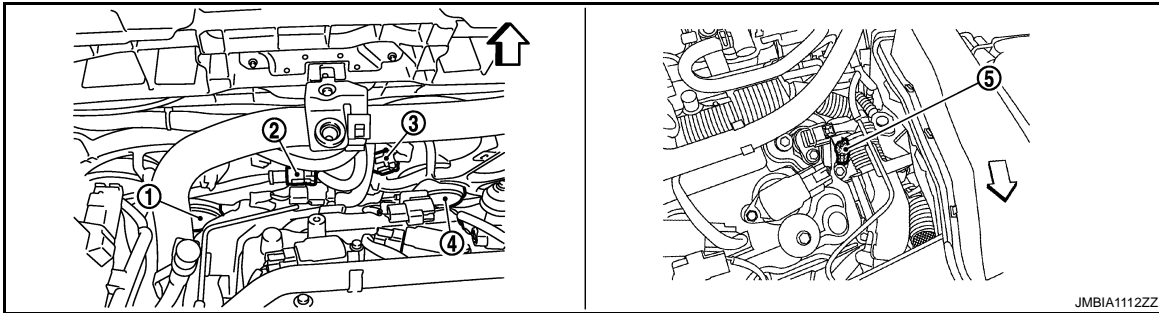

- 1. Cooling fan motor-1
- 2. Cooling fan motor-1 harness connector
- 3. Cooling fan motor-1 harness connector
- 4. Cooling fan motor-2
- 5. Engine coolant temperature sensor

↶ : Vehicle front

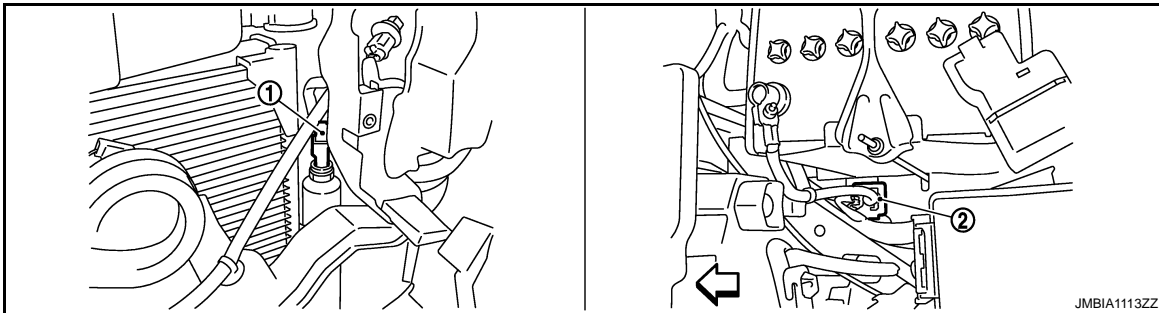

- 1. Refrigerant pressure sensor
- 2. Battery current sensor

↶ : Vehicle front

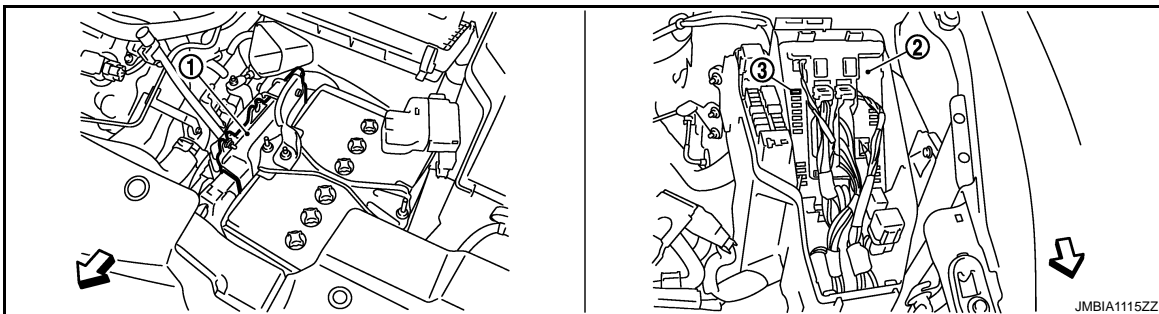

- 1. ECM
- 2. IPDM E/R
- 3. Fuel pump fuse

↶ : Vehicle front

A
EC
C
D
E
F
G
H
I
J
K
L
M
N
O
P

ENGINE CONTROL SYSTEM

< FUNCTION DIAGNOSIS >

[VQ35DE]

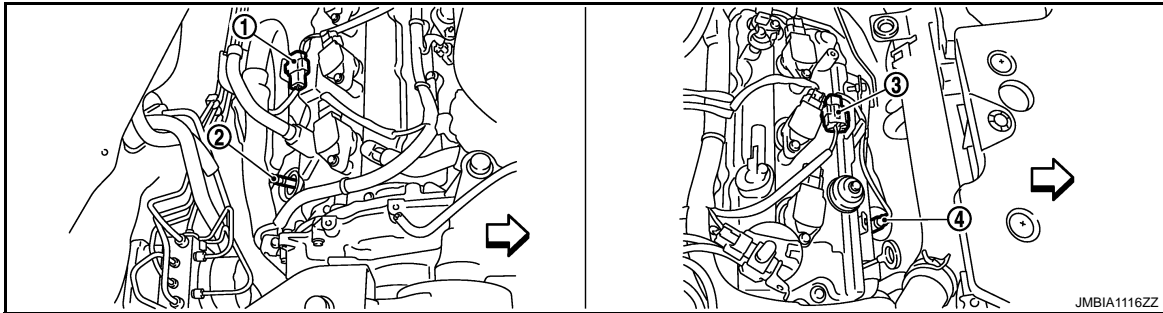
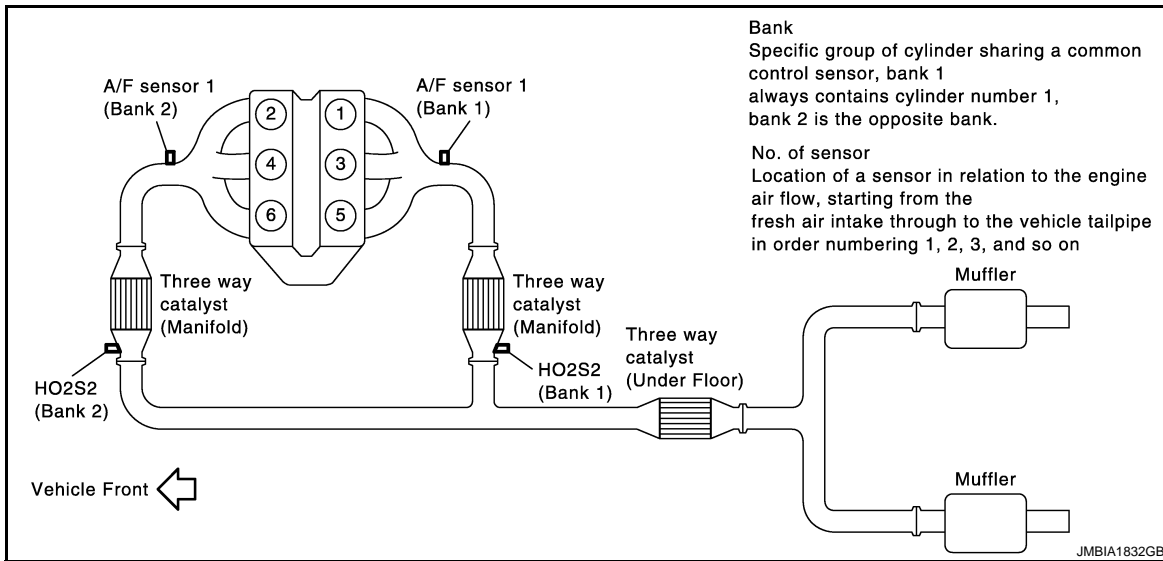

- 1. A/F sensor 1 (bank 1) harness connector
- 2. A/F sensor 1 (bank 1)
- 3. A/F sensor 1 (bank 2) harness connector

- 4. A/F sensor 1 (bank 2)

← : Vehicle front

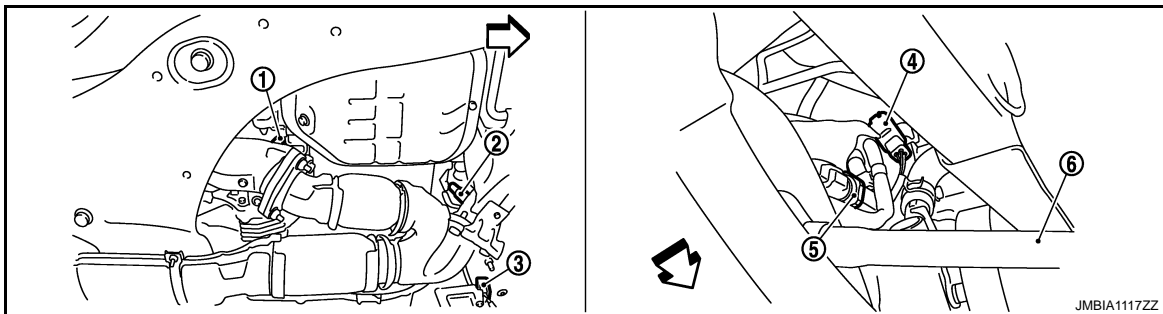

- 1. HO2S2 (bank 1)
- 2. HO2S2 (bank 2)
- 3. HO2S2 (bank 2) harness connector
- 4. HO2S2 (bank 1) harness connector
- 5. Power steering pressure sensor
- 6. Drive shaft (RH)

← : Vehicle front

A

EC

C

D

E

F

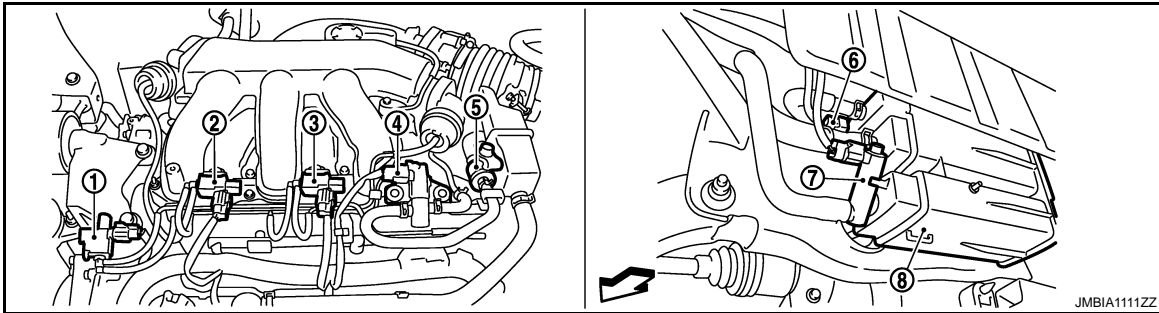

- 1. Electronic controlled engine mount control solenoid valve
- 2. VIAS control solenoid valve 1
- 3. VIAS control solenoid valve 2
- 4. EVAP canister purge volume control solenoid valve
- 5. EVAP service port
- 6. EVAP control system pressure sensor
- 7. EVAP canister vent control valve
- 8. EVAP canister

← : Vehicle front

G

H

I

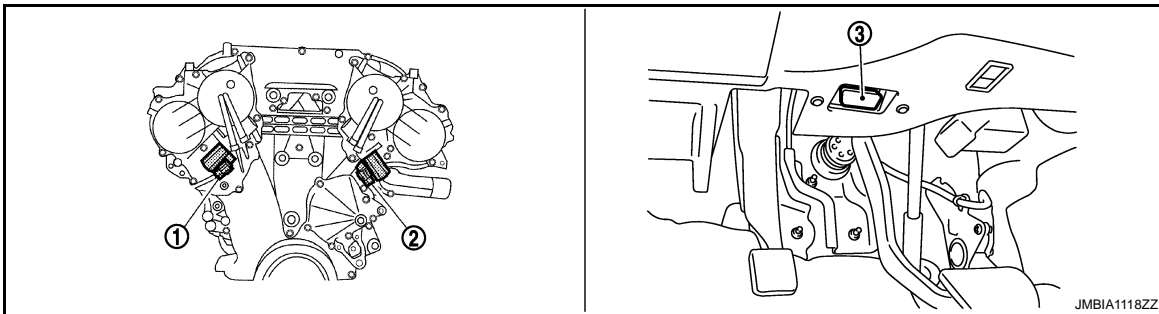

- 1. Intake valve timing control solenoid valve (bank 1)
- 2. Intake valve timing control solenoid valve (bank 2)
- 3. Data link connector

J

K

L

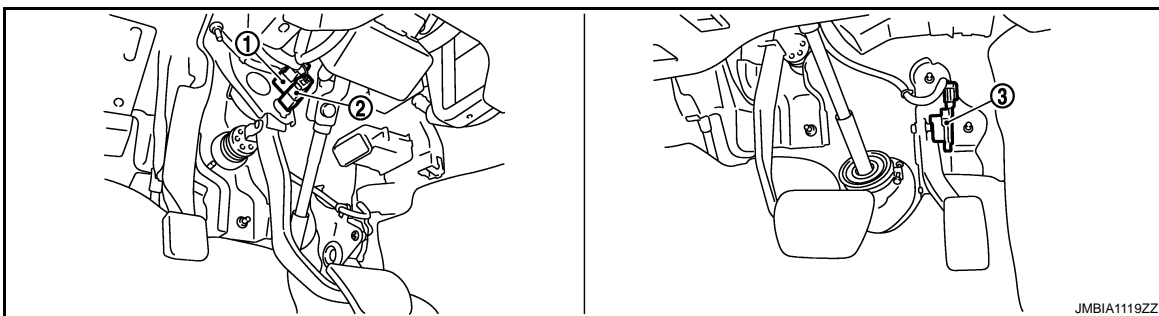

- 1. Stop lamp switch
- 2. ASCD brake switch
- 3. Accelerator pedal position sensor

N

O

P

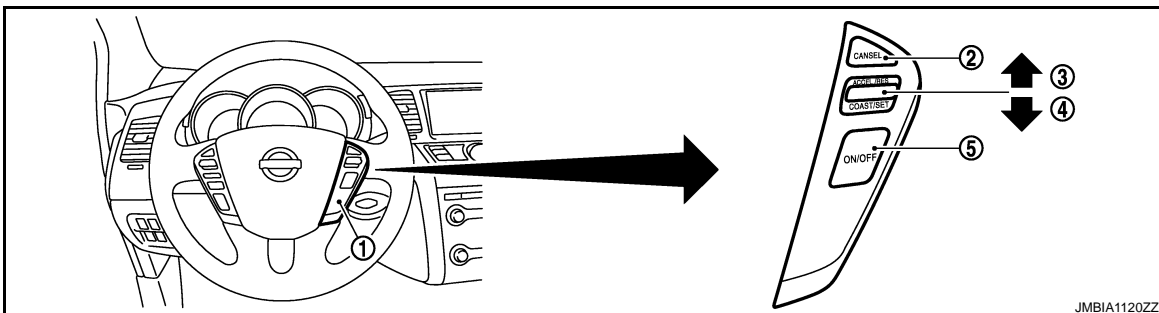

ENGINE CONTROL SYSTEM

[VQ35DE]

< FUNCTION DIAGNOSIS >

- | | | |
|-------------------------|------------------|-----------------------------|
| 1. ASCD steering switch | 2. CANCEL switch | 3. RESUME/ACCELERATE switch |
| 4. SET/COAST switch | 5. MAIN switch | |

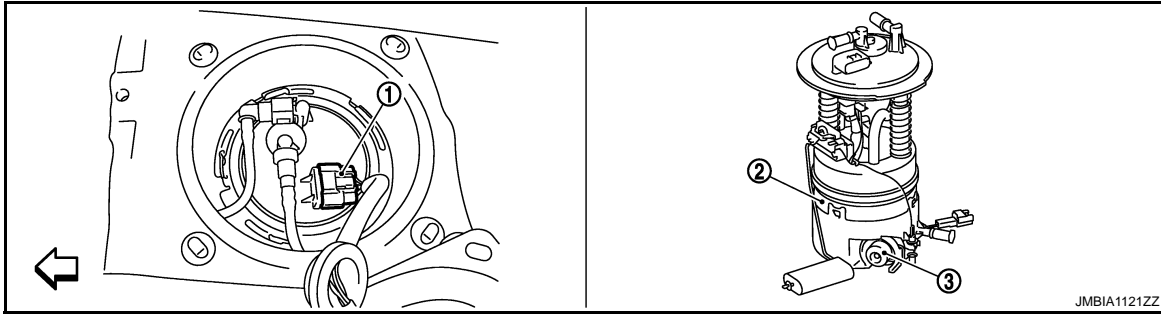

1. Fuel level sensor unit and fuel pump harness connector 2. Fuel level sensor unit and fuel pump 3. Fuel pressure regulator

← : Vehicle front

Component Description

INFOID:000000003387888

Component	Reference
A/F sensor 1	EC-186, "Description"
A/F sensor 1 heater	EC-145, "Description"
Accelerator pedal position sensor	EC-413, "Description"
ASCD brake switch	EC-380, "Description"
ASCD steering switch	EC-377, "Description"
Battery current sensor	EC-365, "Description"
Camshaft position sensor (PHASE)	EC-264, "Description"
Cooling fan motor	EC-434, "Description"
Crankshaft position sensor (POS)	EC-260, "Description"
Electric throttle control actuator	EC-411, "Description"
Electronic controlled engine mount	EC-441, "Description"
Engine coolant temperature sensor	EC-170, "Description"
Engine oil temperature sensor	EC-242, "Description"
EVAP canister purge volume control solenoid valve	EC-284, "Description"
EVAP canister vent control valve	EC-292, "Description"
EVAP control system pressure sensor	EC-300, "Description"
Fuel injector	EC-444, "Description"
Fuel level sensor	EC-327, "Description"
Fuel pump	EC-447, "Description"
Fuel tank temperature sensor	EC-236, "Description"
Heated oxygen sensor 2	EC-203, "Description"
Heated oxygen sensor 2 heater	EC-148, "Description"
Ignition coil with power transistor	EC-451, "Description"
Intake air temperature sensor	EC-167, "Description"
Intake valve timing control solenoid valve	EC-151, "Description"
Knock sensor	EC-257, "Description"
Mass air flow sensor	EC-154, "Description"

ENGINE CONTROL SYSTEM

< FUNCTION DIAGNOSIS >

[VQ35DE]

Component	Reference	
PCV valve	EC-462. "Description"	A
Power steering pressure sensor	EC-339. "Description"	
Power valves 1 and 2	EC-466. "Description"	EC
Refrigerant pressure sensor	EC-463. "Description"	
Stop lamp switch	EC-399. "Description"	
TCM	EC-350. "Description"	C
Throttle control motor	EC-408. "Description"	
Throttle control motor relay	EC-402. "Description"	D
Throttle position sensor	EC-175. "Description"	
VIAS control solenoid valve 1	EC-393. "Description"	E
VIAS control solenoid valve 2	EC-396. "Description"	

F
G
H
I
J
K
L
M
N
O
P

MULTIPOINT FUEL INJECTION SYSTEM

[VQ35DE]

< FUNCTION DIAGNOSIS >

MULTIPOINT FUEL INJECTION SYSTEM

System Diagram

INFOID:000000003387889

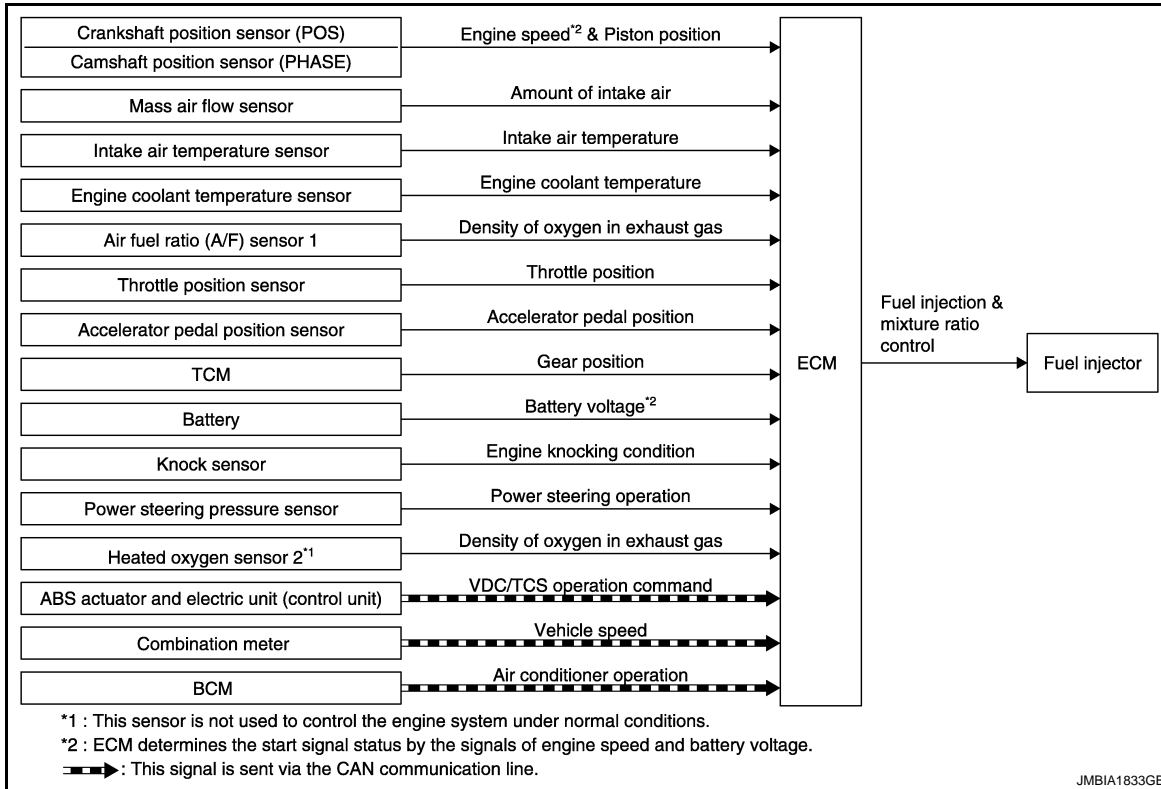

System Description

INFOID:000000003387890

INPUT/OUTPUT SIGNAL CHART

Sensor	Input signal to ECM	ECM function	Actuator
Crankshaft position sensor (POS)	Engine speed*3	Fuel injection & mixture ratio control	Fuel injector
Camshaft position sensor (PHASE)	Piston position		
Mass air flow sensor	Amount of intake air		
Intake air temperature sensor	Intake air temperature		
Engine coolant temperature sensor	Engine coolant temperature		
Air fuel ratio (A/F) sensor 1	Density of oxygen in exhaust gas		
Throttle position sensor	Throttle position		
Accelerator pedal position sensor	Accelerator pedal position		
TCM	Gear position		
Battery	Battery voltage*3		
Knock sensor	Engine knocking condition		
Power steering pressure sensor	Power steering operation		
Heated oxygen sensor 2*1	Density of oxygen in exhaust gas		
ABS actuator and electric unit (control unit)	VDC/TCS operation command*2		
Combination meter	Vehicle speed*2		
BCM	Air conditioner operation*2		

*1: This sensor is not used to control the engine system under normal conditions.

*2: This signal is sent to the ECM via the CAN communication line.

MULTIPOINT FUEL INJECTION SYSTEM

[VQ35DE]

< FUNCTION DIAGNOSIS >

*3: ECM determines the start signal status by the signals of engine speed and battery voltage.

SYSTEM DESCRIPTION

The amount of fuel injected from the fuel injector is determined by the ECM. The ECM controls the length of time the valve remains open (injection pulse duration). The amount of fuel injected is a program value in the ECM memory. The program value is preset by engine operating conditions. These conditions are determined by input signals (for engine speed and intake air) from the crankshaft position sensor (POS), camshaft position sensor (PHASE) and the mass air flow sensor.

VARIOUS FUEL INJECTION INCREASE/DECREASE COMPENSATION

In addition, the amount of fuel injected is compensated to improve engine performance under various operating conditions as listed below.

<Fuel increase>

- During warm-up
- When starting the engine
- During acceleration
- Hot-engine operation
- When selector lever position is changed from N to D
- High-load, high-speed operation

<Fuel decrease>

- During deceleration
- During high engine speed operation

MIXTURE RATIO FEEDBACK CONTROL (CLOSED LOOP CONTROL)

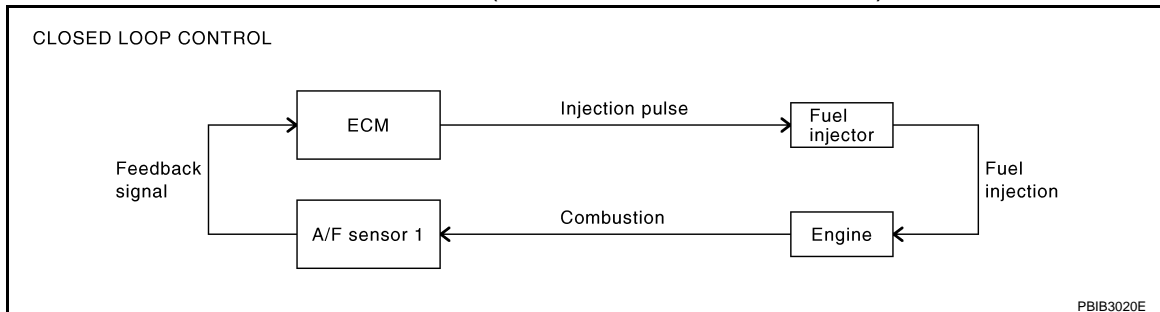

The mixture ratio feedback system provides the best air-fuel mixture ratio for drive ability and emission control. The three way catalyst (manifold) can better reduce CO, HC and NO_x emissions. This system uses A/F sensor 1 in the exhaust manifold to monitor whether the engine operation is rich or lean. The ECM adjusts the injection pulse width according to the sensor voltage signal. For more information about A/F sensor 1, refer to [EC-186, "Description"](#). This maintains the mixture ratio within the range of stoichiometric (ideal air-fuel mixture).

This stage is referred to as the closed loop control condition.

Heated oxygen sensor 2 is located downstream of the three way catalyst (manifold). Even if the switching characteristics of A/F sensor 1 shift, the air-fuel ratio is controlled to stoichiometric by the signal from heated oxygen sensor 2.

• Open Loop Control

The open loop system condition refers to when the ECM detects any of the following conditions. Feedback control stops in order to maintain stabilized fuel combustion.

- Deceleration and acceleration
- High-load, high-speed operation
- Malfunction of A/F sensor 1 or its circuit
- Insufficient activation of A/F sensor 1 at low engine coolant temperature
- High engine coolant temperature
- During warm-up
- After shifting from N to D
- When starting the engine

MIXTURE RATIO SELF-LEARNING CONTROL

The mixture ratio feedback control system monitors the mixture ratio signal transmitted from A/F sensor 1. This feedback signal is then sent to the ECM. The ECM controls the basic mixture ratio as close to the theoretical mixture ratio as possible. However, the basic mixture ratio is not necessarily controlled as originally

MULTIPOINT FUEL INJECTION SYSTEM

[VQ35DE]

< FUNCTION DIAGNOSIS >

designed. Both manufacturing differences (i.e., mass air flow sensor hot wire) and characteristic changes during operation (i.e., fuel injector clogging) directly affect mixture ratio.

Accordingly, the difference between the basic and theoretical mixture ratios is monitored in this system. This is then computed in terms of "injection pulse duration" to automatically compensate for the difference between the two ratios.

"Fuel trim" refers to the feedback compensation value compared against the basic injection duration. Fuel trim includes "short-term fuel trim" and "long-term fuel trim".

"Short-term fuel trim" is the short-term fuel compensation used to maintain the mixture ratio at its theoretical value. The signal from A/F sensor 1 indicates whether the mixture ratio is RICH or LEAN compared to the theoretical value. The signal then triggers a reduction in fuel volume if the mixture ratio is rich, and an increase in fuel volume if it is lean.

"Long-term fuel trim" is overall fuel compensation carried out over time to compensate for continual deviation of the "short-term fuel trim" from the central value. Continual deviation will occur due to individual engine differences, wear over time and changes in the usage environment.

FUEL INJECTION TIMING

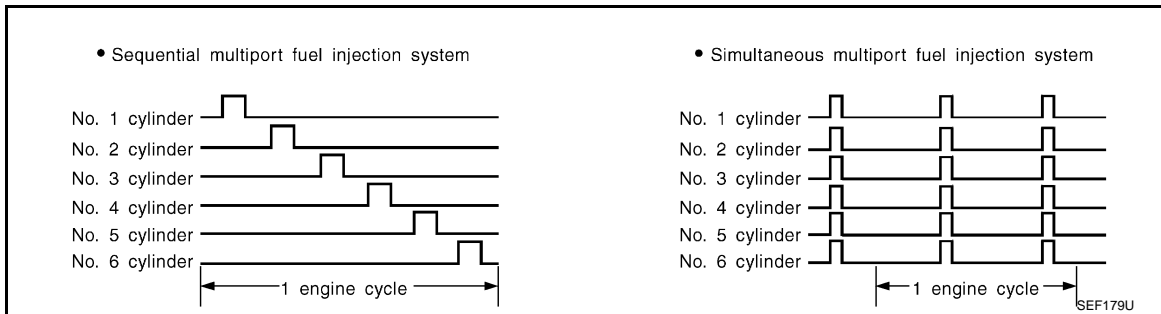

Two types of systems are used.

- Sequential Multiport Fuel Injection System

Fuel is injected into each cylinder during each engine cycle according to the ignition order. This system is used when the engine is running.

- Simultaneous Multiport Fuel Injection System

Fuel is injected simultaneously into all six cylinders twice each engine cycle. In other words, pulse signals of the same width are simultaneously transmitted from the ECM.

The six injectors will then receive the signals 2 times for each engine cycle.

This system is used when the engine is being started and/or if the fail-safe system (CPU) is operating.

FUEL SHUT-OFF

Fuel to each cylinder is cut off during deceleration, operation of the engine at excessively high speeds or operation of the vehicle at excessively high speeds.

MULTIPOINT FUEL INJECTION SYSTEM

< FUNCTION DIAGNOSIS >

[VQ35DE]

Component Parts Location

INFOID:000000003573769

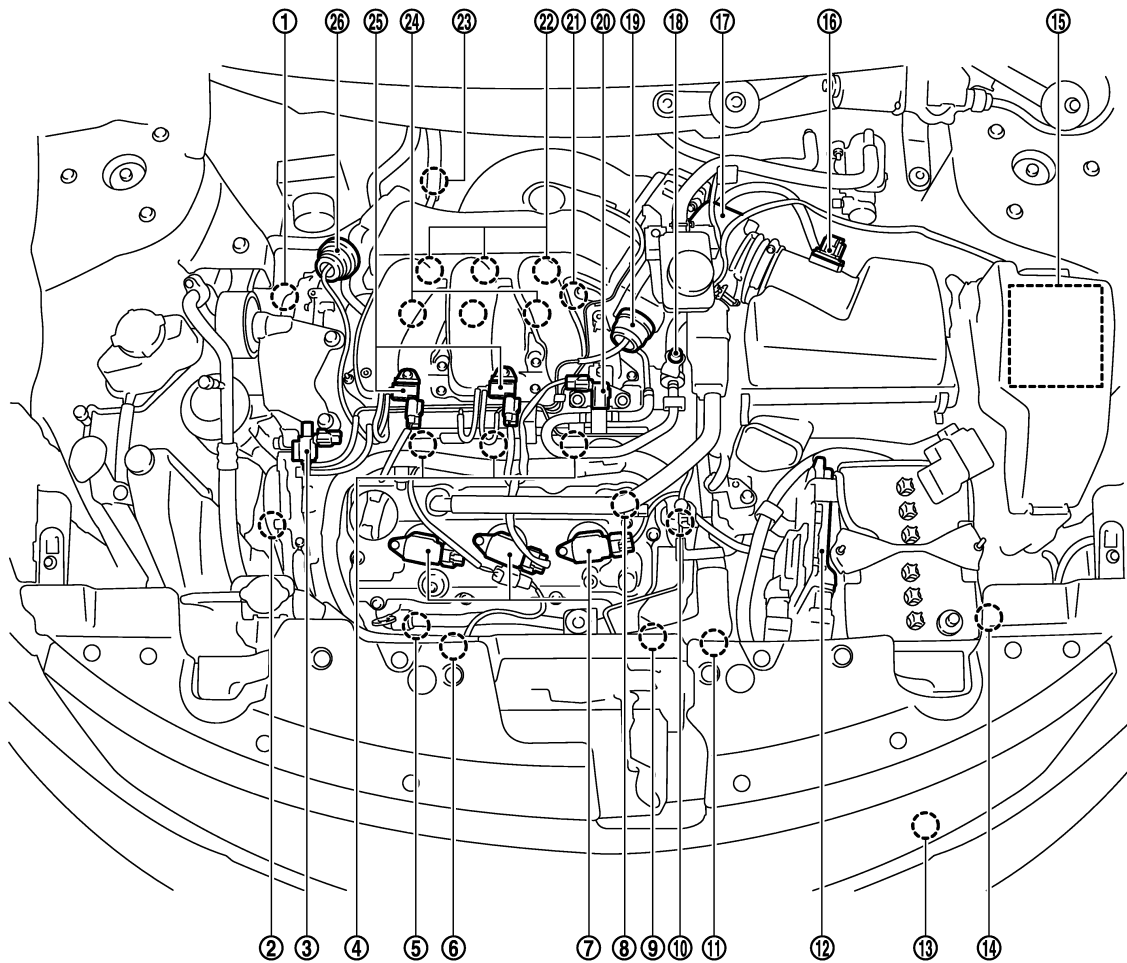

JMBIA1108ZZ

- | | | |
|---|--|--|
| 1. Intake valve timing control solenoid valve (bank 1) | 2. Intake valve timing control solenoid valve (bank 2) | 3. Electronic controlled engine mount control solenoid valve |
| 4. Fuel injector (bank 2) | 5. A/F sensor 1 (bank 2) | 6. Cooling fan motor-2 |
| 7. Ignition coil (with power transistor) and spark plug (bank 2) | 8. Camshaft position sensor (PHASE) (bank 2) | 9. Crankshaft position sensor (POS) |
| 10. Engine coolant temperature sensor | 11. Cooling fan motor-1 | 12. ECM |
| 13. Refrigerant pressure sensor | 14. Battery current sensor | 15. IPDM E/R |
| 16. Mass air flow sensor (with intake air temperature sensor) | 17. Electric throttle control actuator | 18. EVAP service port |
| 19. Power valve actuator 2 | 20. EVAP canister purge volume control solenoid valve | 21. Camshaft position sensor (PHASE) (bank 1) |
| 22. Ignition coil (with power transistor) and spark plug (bank 1) | 23. A/F sensor 1 (bank 1) | 24. Fuel injector (bank 1) |
| 25. VIAS control solenoid valve 1 and 2 | 26. Power valve actuator 1 | |

MULTIPOINT FUEL INJECTION SYSTEM

< FUNCTION DIAGNOSIS >

[VQ35DE]

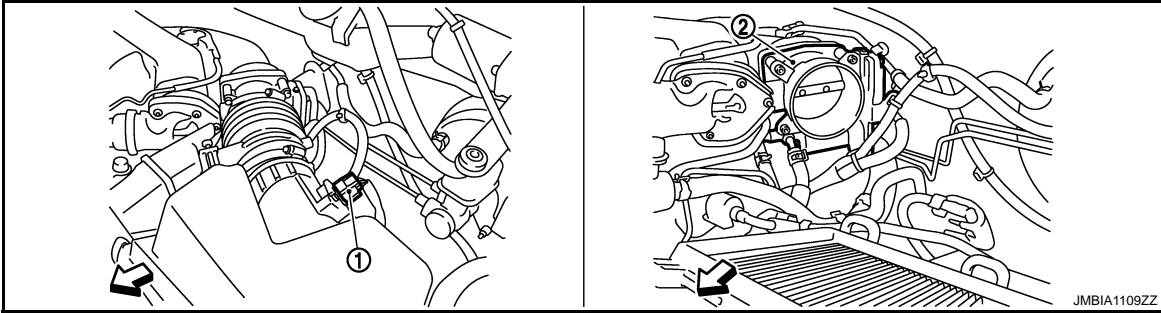

- 1. Mas air flow sensor (with intake air temperature sensor)
- 2. Electric throttle control actuator

← : Vehicle front

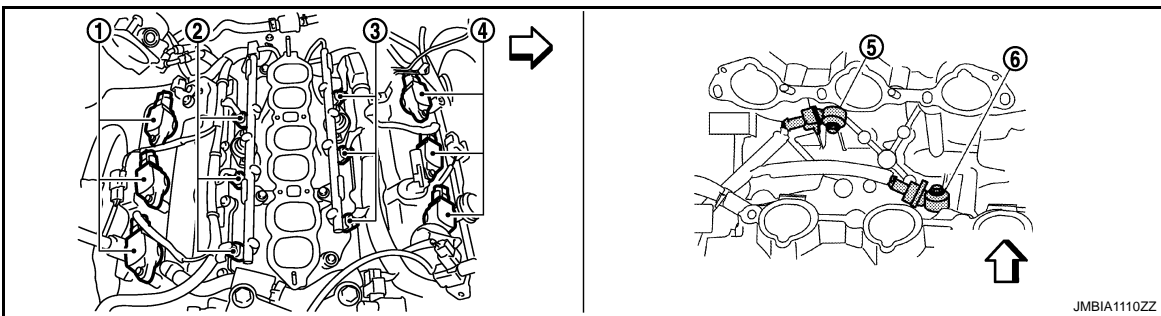

- 1. Ignition coil (with power transistor and spark plug (bank 1))
- 2. Fuel injector (bank 1)
- 3. Fuel injector (bank 2)
- 4. Ignition coil (with power transistor and spark plug (bank 2))
- 5. Knock sensor (bank 2)
- 6. Knock sensor (bank 1)

← : Vehicle front

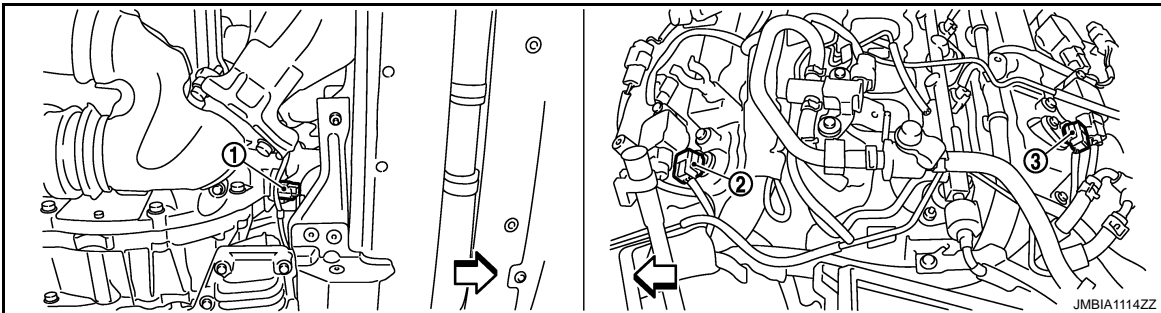

- 1. Crankshaft position sensor (POS)
- 2. Camshaft position sensor (PHASE) (bank 1)
- 3. Camshaft position sensor (PHASE) (bank 2)

← : Vehicle front

MULTIPOINT FUEL INJECTION SYSTEM

< FUNCTION DIAGNOSIS >

[VQ35DE]

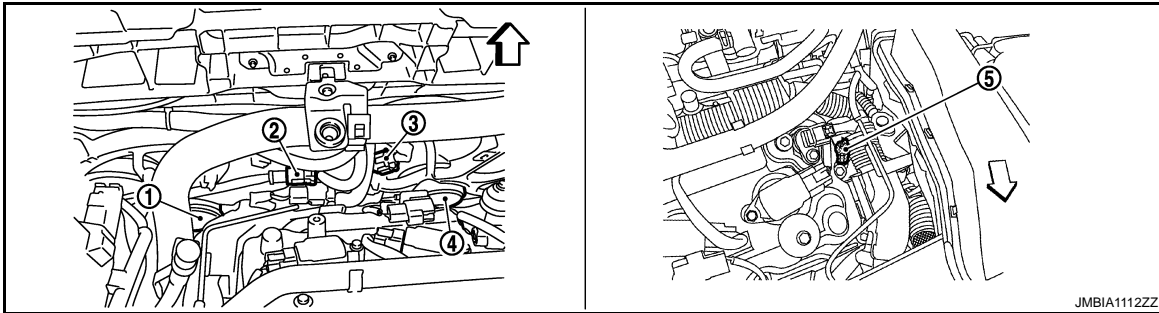

- 1. Cooling fan motor-1
- 2. Cooling fan motor-1 harness connector
- 3. Cooling fan motor-1 harness connector
- 4. Cooling fan motor-2
- 5. Engine coolant temperature sensor

↶ : Vehicle front

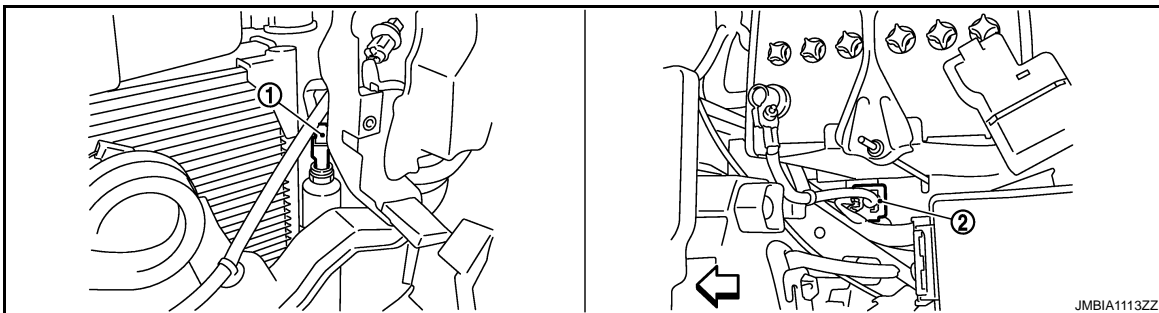

- 1. Refrigerant pressure sensor
- 2. Battery current sensor

↶ : Vehicle front

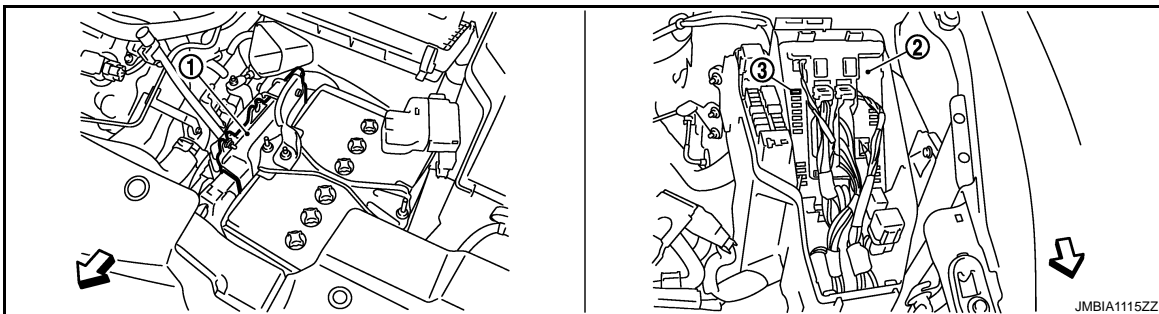

- 1. ECM
- 2. IPDM E/R
- 3. Fuel pump fuse

↶ : Vehicle front

A
EC
C
D
E
F
G
H
I
J
K
L
M
N
O
P

MULTIPOINT FUEL INJECTION SYSTEM

< FUNCTION DIAGNOSIS >

[VQ35DE]

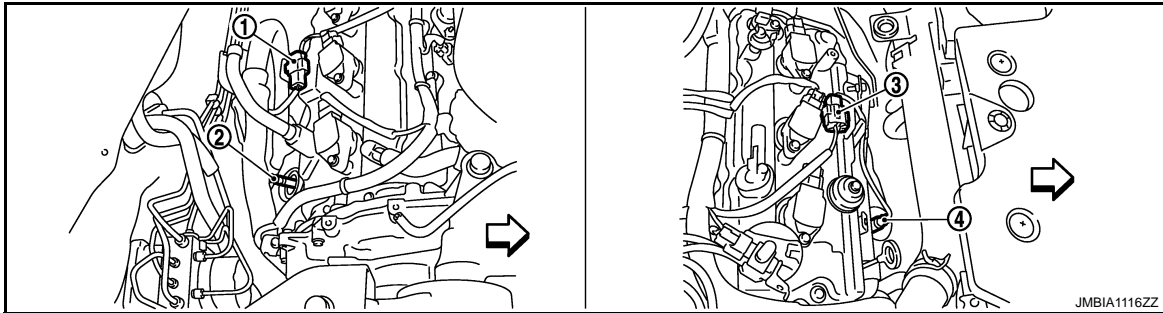
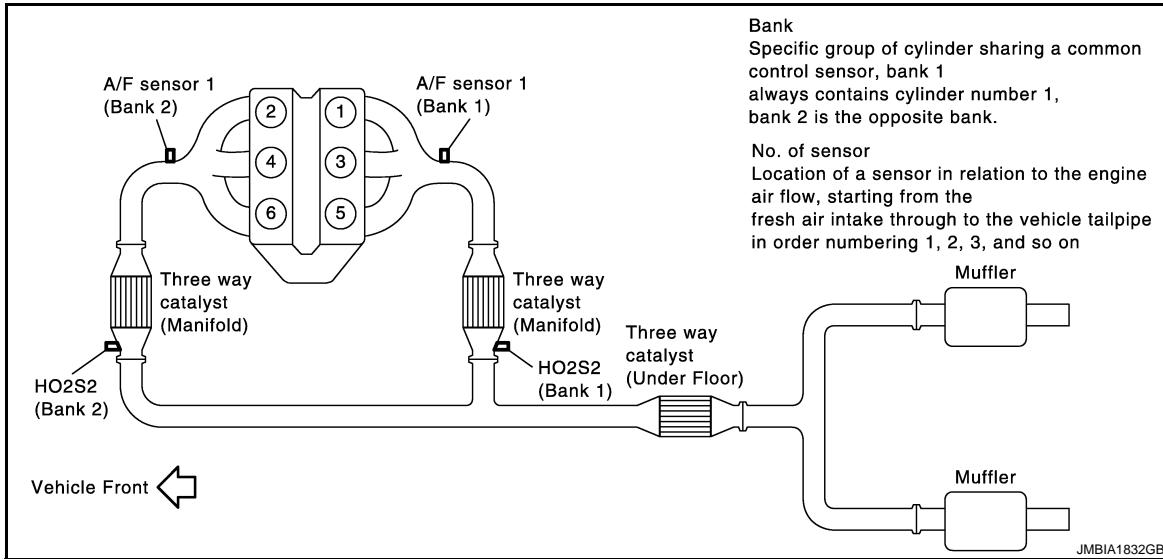

- 1. A/F sensor 1 (bank 1) harness connector
- 2. A/F sensor 1 (bank 1)
- 3. A/F sensor 1 (bank 2) harness connector

- 4. A/F sensor 1 (bank 2)

← : Vehicle front

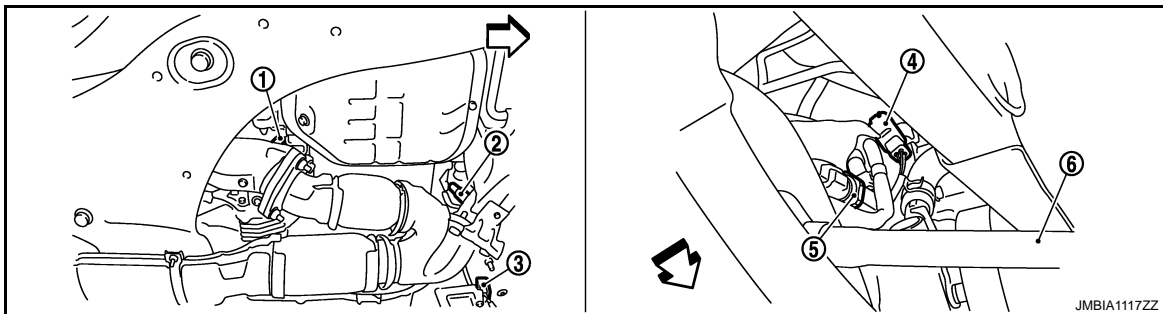

- 1. HO2S2 (bank 1)
- 2. HO2S2 (bank 2)
- 3. HO2S2 (bank 2) harness connector
- 4. HO2S2 (bank 1) harness connector
- 5. Power steering pressure sensor
- 6. Drive shaft (RH)

← : Vehicle front

MULTIPOINT FUEL INJECTION SYSTEM

< FUNCTION DIAGNOSIS >

[VQ35DE]

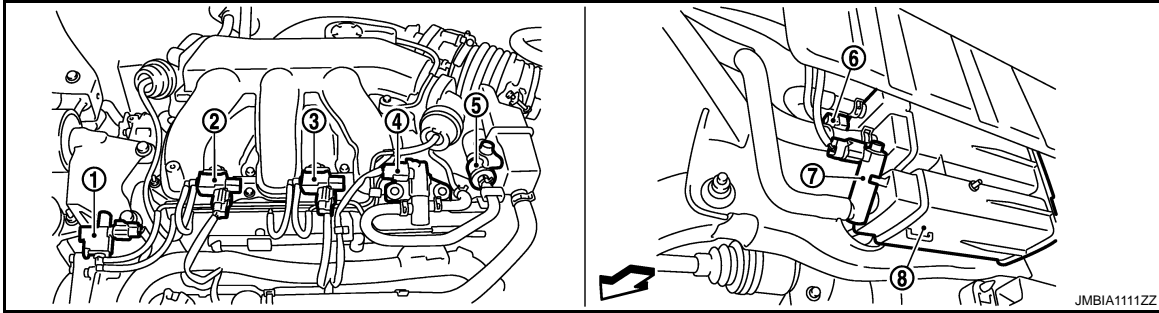

- | | | |
|--|----------------------------------|--|
| 1. Electronic controlled engine mount control solenoid valve | 2. VIAS control solenoid valve 1 | 3. VIAS control solenoid valve 2 |
| 4. EVAP canister purge volume control solenoid valve | 5. EVAP service port | 6. EVAP control system pressure sensor |
| 7. EVAP canister vent control valve | 8. EVAP canister | |

← : Vehicle front

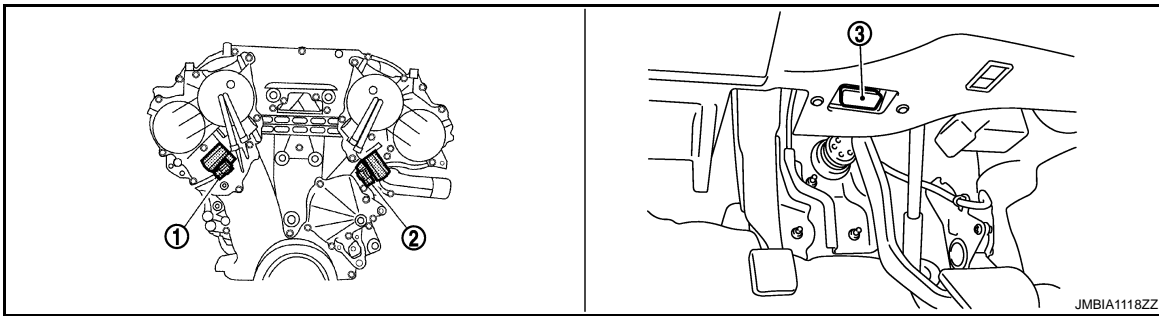

- | | | |
|--|--|------------------------|
| 1. Intake valve timing control solenoid valve (bank 1) | 2. Intake valve timing control solenoid valve (bank 2) | 3. Data link connector |
|--|--|------------------------|

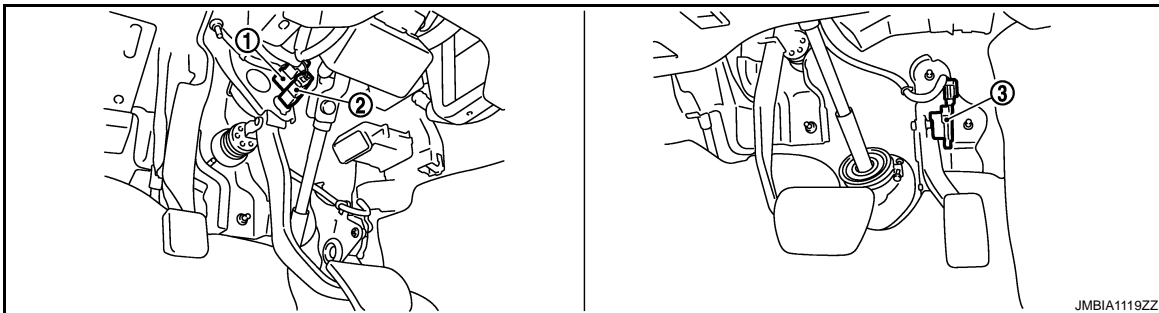

- | | | |
|---------------------|----------------------|--------------------------------------|
| 1. Stop lamp switch | 2. ASCD brake switch | 3. Accelerator pedal position sensor |
|---------------------|----------------------|--------------------------------------|

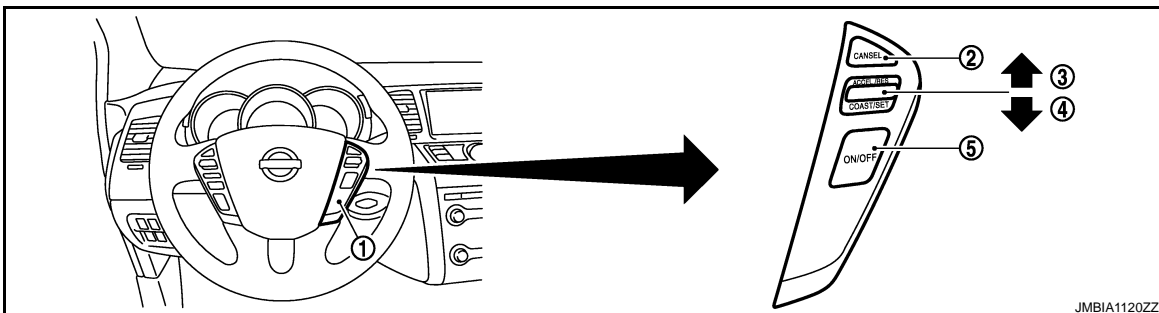

A
EC
C
D
E
F
G
H
I
J
K
L
M
N
O
P

MULTIPOINT FUEL INJECTION SYSTEM

[VQ35DE]

< FUNCTION DIAGNOSIS >

- | | | |
|-------------------------|------------------|-----------------------------|
| 1. ASCD steering switch | 2. CANCEL switch | 3. RESUME/ACCELERATE switch |
| 4. SET/COAST switch | 5. MAIN switch | |

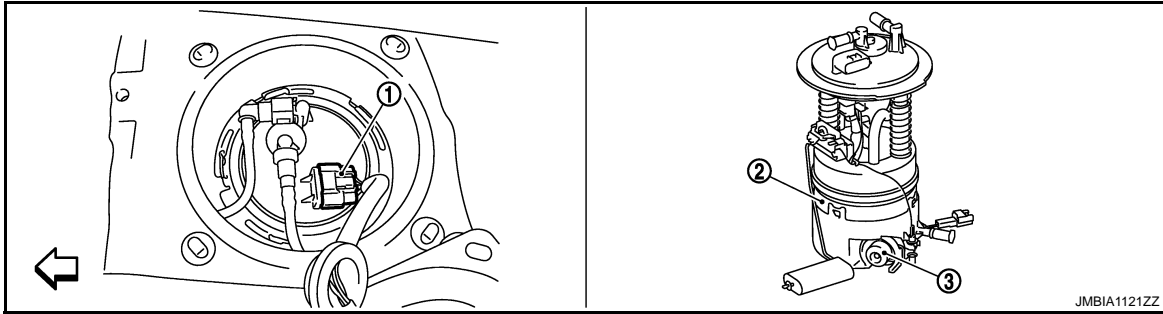

1. Fuel level sensor unit and fuel pump harness connector 2. Fuel level sensor unit and fuel pump 3. Fuel pressure regulator

← : Vehicle front

Component Description

INFOID:000000003387892

Component	Reference
A/F sensor 1	EC-186, "Description"
Accelerator pedal position sensor	EC-413, "Description"
Camshaft position sensor (PHASE)	EC-264, "Description"
Crankshaft position sensor (POS)	EC-260, "Description"
Engine coolant temperature sensor	EC-170, "Description"
Fuel injector	EC-444, "Description"
Heated oxygen sensor 2	EC-203, "Description"
Intake air temperature sensor	EC-167, "Description"
Knock sensor	EC-257, "Description"
Mass air flow sensor	EC-154, "Description"
Power steering pressure sensor	EC-339, "Description"
TCM	EC-350, "Description"
Throttle position sensor	EC-175, "Description"

ELECTRIC IGNITION SYSTEM

System Diagram

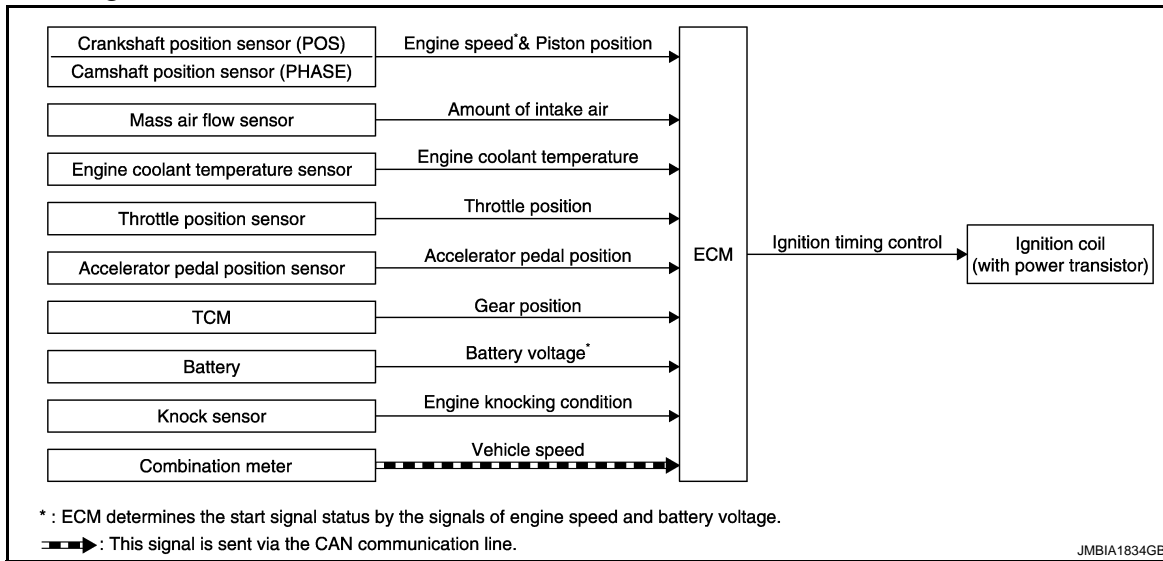

System Description

INFOID:000000003387894

INPUT/OUTPUT SIGNAL CHART

Sensor	Input signal to ECM	ECM function	Actuator
Crankshaft position sensor (POS)	Engine speed*2 Piston position	Ignition timing control	Ignition coil (with power transistor)
Camshaft position sensor (PHASE)			
Mass air flow sensor	Amount of intake air		
Engine coolant temperature sensor	Engine coolant temperature		
Throttle position sensor	Throttle position		
Accelerator pedal position sensor	Accelerator pedal position		
TCM	Gear position		
Battery	Battery voltage*2		
Knock sensor	Engine knocking		
Combination meter	Vehicle speed*1		

*1: This signal is sent to the ECM via the CAN communication line.

*2: ECM determines the start signal status by the signals of engine speed and battery voltage.

SYSTEM DESCRIPTION

Ignition order: 1 - 2 - 3 - 4 - 5 - 6

The ignition timing is controlled by the ECM to maintain the best air-fuel ratio for every running condition of the engine. The ignition timing data is stored in the ECM.

The ECM receives information such as the injection pulse width and camshaft position sensor (PHASE) signal. Computing this information, ignition signals are transmitted to the power transistor.

During the following conditions, the ignition timing is revised by the ECM according to the other data stored in the ECM.

- At starting
- During warm-up
- At idle
- At low battery voltage
- During acceleration

The knock sensor retard system is designed only for emergencies. The basic ignition timing is programmed within the anti-knocking zone, if recommended fuel is used under dry conditions. The retard system does not

ELECTRIC IGNITION SYSTEM

[VQ35DE]

< FUNCTION DIAGNOSIS >

operate under normal driving conditions. If engine knocking occurs, the knock sensor monitors the condition. The signal is transmitted to the ECM. The ECM retards the ignition timing to eliminate the knocking condition.

Component Parts Location

INFOID:000000003573784

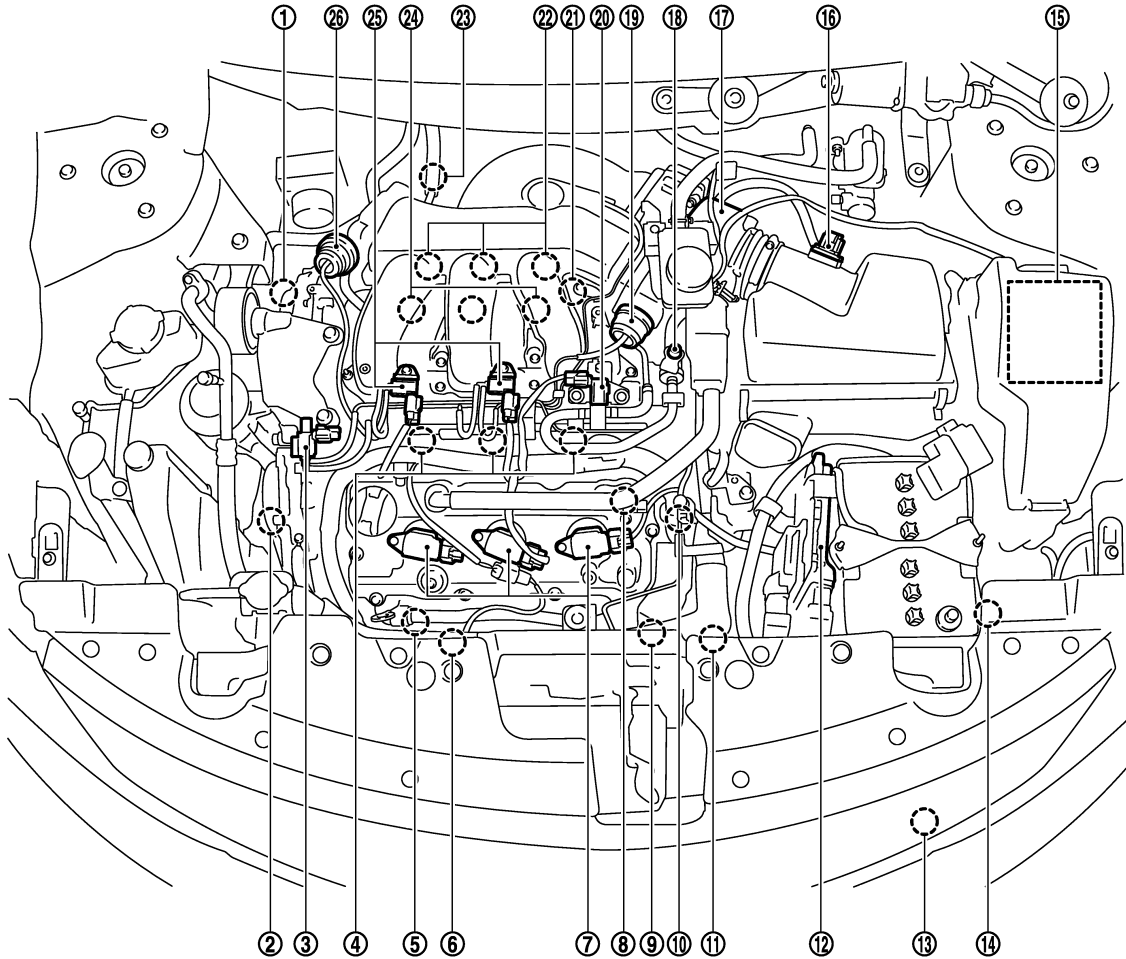

JMBIA1108ZZ

- | | | |
|---|--|--|
| 1. Intake valve timing control solenoid valve (bank 1) | 2. Intake valve timing control solenoid valve (bank 2) | 3. Electronic controlled engine mount control solenoid valve |
| 4. Fuel injector (bank 2) | 5. A/F sensor 1 (bank 2) | 6. Cooling fan motor-2 |
| 7. Ignition coil (with power transistor) and spark plug (bank 2) | 8. Camshaft position sensor (PHASE) (bank 2) | 9. Crankshaft position sensor (POS) |
| 10. Engine coolant temperature sensor | 11. Cooling fan motor-1 | 12. ECM |
| 13. Refrigerant pressure sensor | 14. Battery current sensor | 15. IPDM E/R |
| 16. Mass air flow sensor (with intake air temperature sensor) | 17. Electric throttle control actuator | 18. EVAP service port |
| 19. Power valve actuator 2 | 20. EVAP canister purge volume control solenoid valve | 21. Camshaft position sensor (PHASE) (bank 1) |
| 22. Ignition coil (with power transistor) and spark plug (bank 1) | 23. A/F sensor 1 (bank 1) | 24. Fuel injector (bank 1) |
| 25. VIAS control solenoid valve 1 and 2 | 26. Power valve actuator 1 | |

ELECTRIC IGNITION SYSTEM

< FUNCTION DIAGNOSIS >

[VQ35DE]

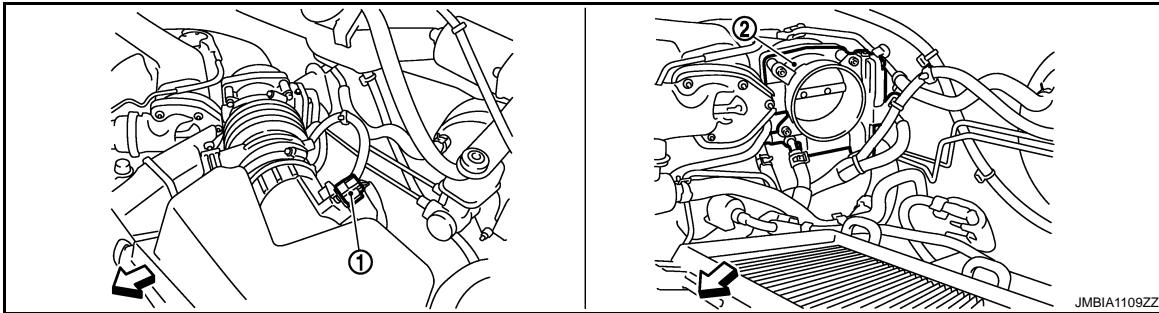

- 1. Mas air flow sensor (with intake air temperature sensor)
- 2. Electric throttle control actuator

← : Vehicle front

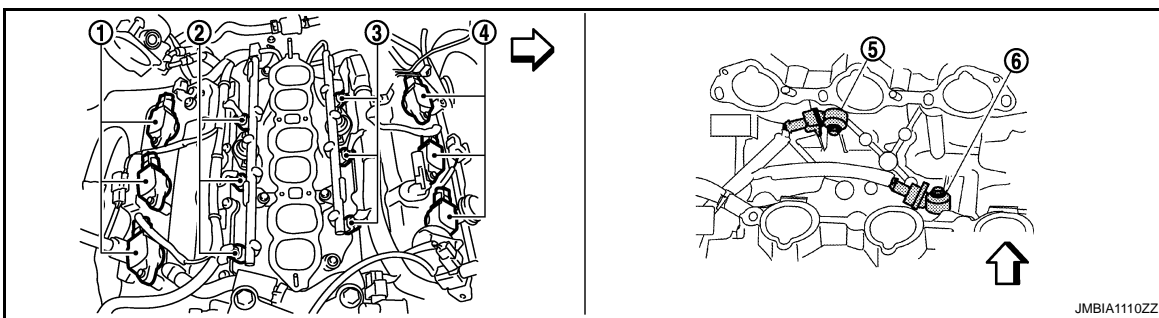

- 1. Ignition coil (with power transistor and spark plug (bank 1))
- 2. Fuel injector (bank 1)
- 3. Fuel injector (bank 2)
- 4. Ignition coil (with power transistor and spark plug (bank 2))
- 5. Knock sensor (bank 2)
- 6. Knock sensor (bank 1)

← : Vehicle front

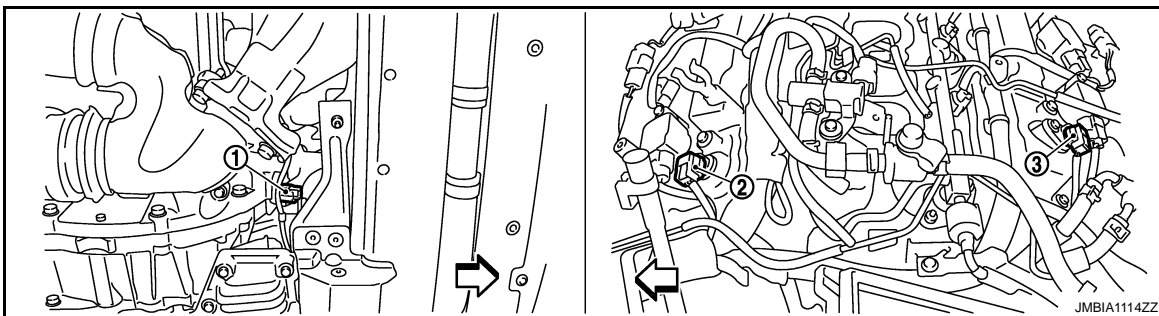

- 1. Crankshaft position sensor (POS)
- 2. Camshaft position sensor (PHASE) (bank 1)
- 3. Camshaft position sensor (PHASE) (bank 2)

← : Vehicle front

A
EC
C
D
E
F
G
H
I
J
K
L
M
N
O
P

ELECTRIC IGNITION SYSTEM

< FUNCTION DIAGNOSIS >

[VQ35DE]

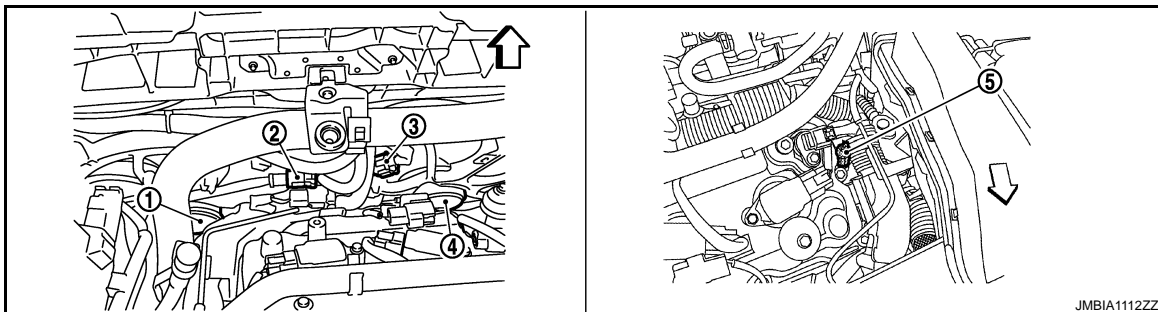

- 1. Cooling fan motor-1
- 2. Cooling fan motor-1 harness connector
- 3. Cooling fan motor-1 harness connector
- 4. Cooling fan motor-2
- 5. Engine coolant temperature sensor

↙ : Vehicle front

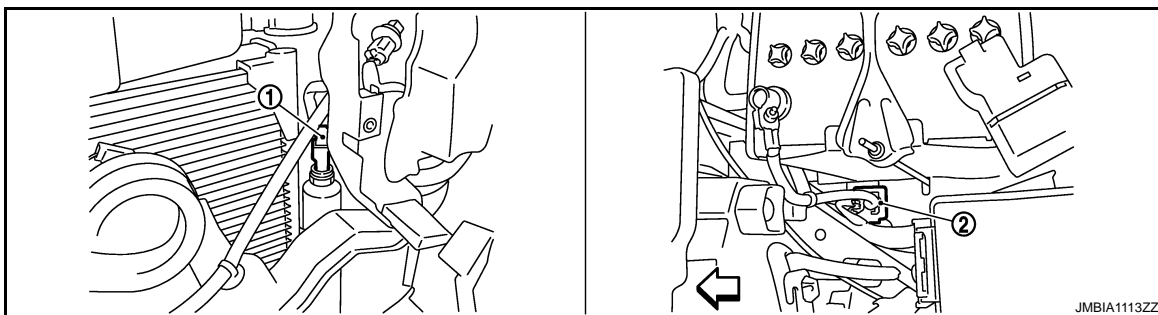

- 1. Refrigerant pressure sensor
- 2. Battery current sensor

↙ : Vehicle front

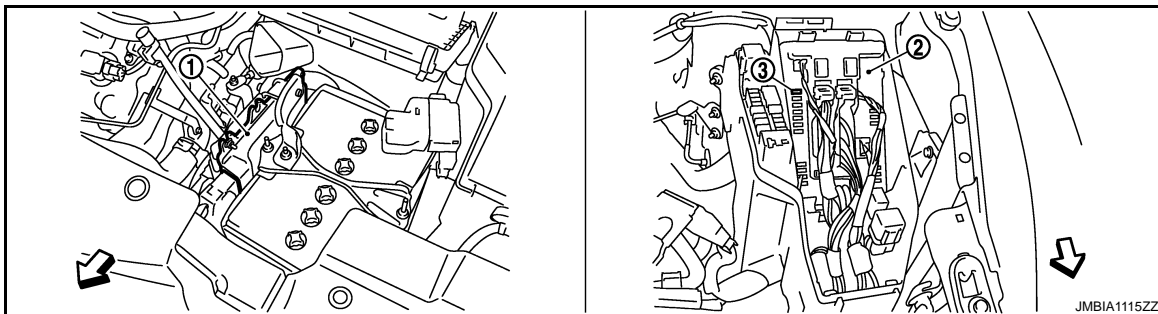

- 1. ECM
- 2. IPDM E/R
- 3. Fuel pump fuse

↙ : Vehicle front

ELECTRIC IGNITION SYSTEM

< FUNCTION DIAGNOSIS >

[VQ35DE]

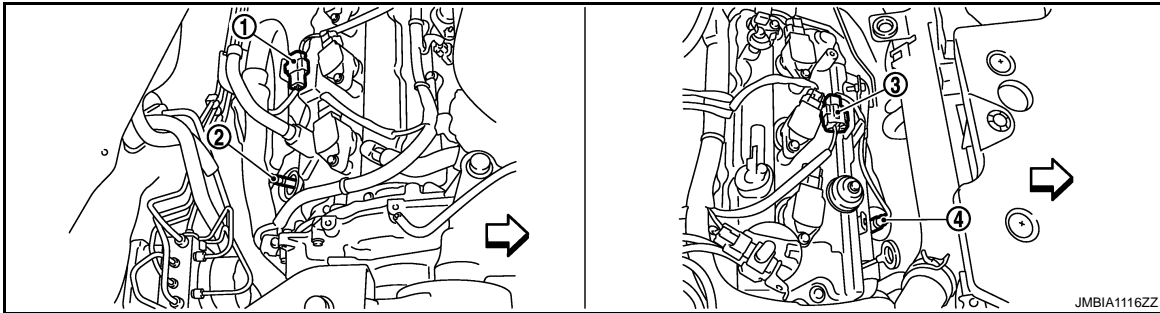
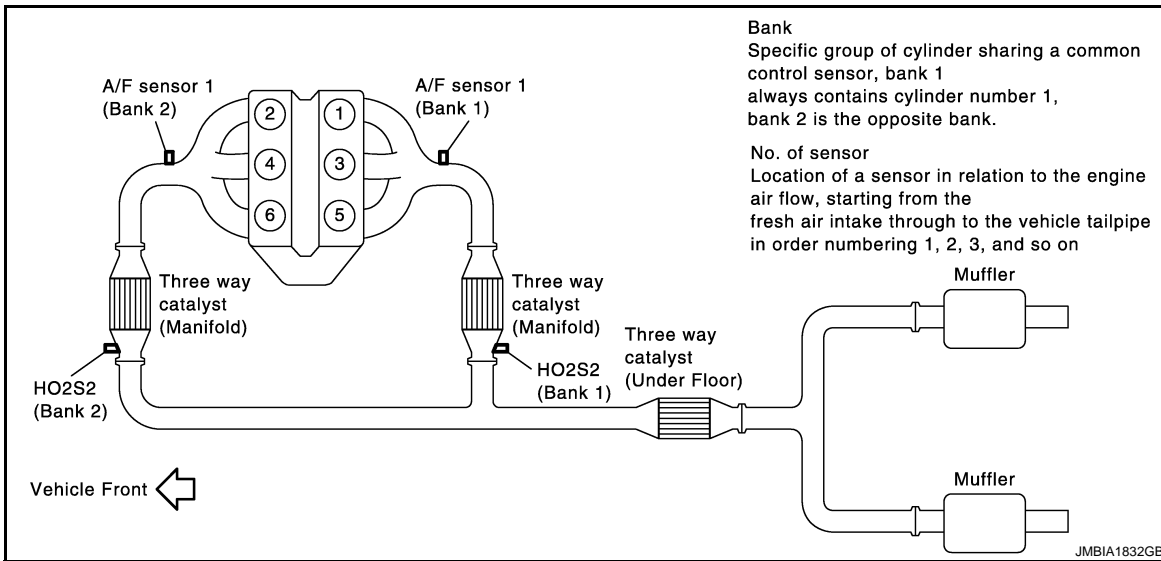

1. A/F sensor 1 (bank 1) harness connector
2. A/F sensor 1 (bank 1)
3. A/F sensor 1 (bank 2) harness connector

4. A/F sensor 1 (bank 2)

← : Vehicle front

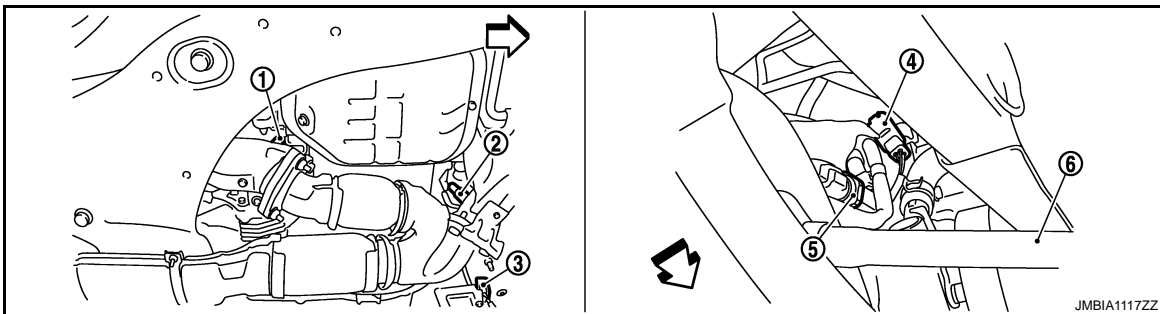

1. HO2S2 (bank 1)
2. HO2S2 (bank 2)
3. HO2S2 (bank 2) harness connector
4. HO2S2 (bank 1) harness connector
5. Power steering pressure sensor
6. Drive shaft (RH)

← : Vehicle front

ELECTRIC IGNITION SYSTEM

< FUNCTION DIAGNOSIS >

[VQ35DE]

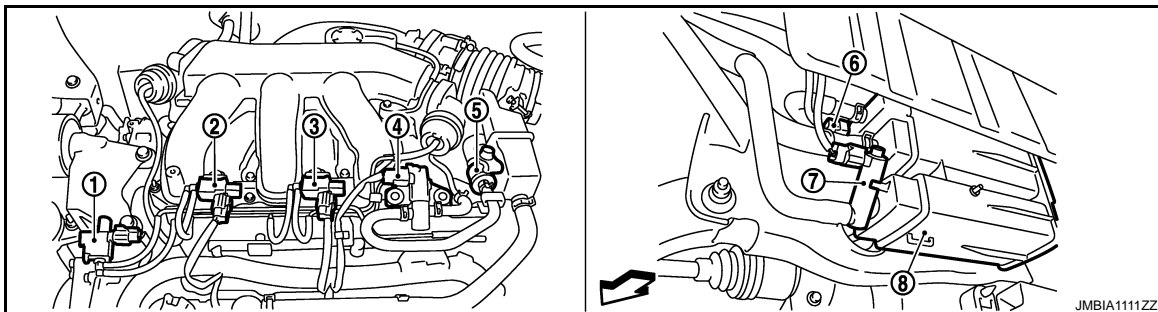

- | | | |
|--|----------------------------------|--|
| 1. Electronic controlled engine mount control solenoid valve | 2. VIAS control solenoid valve 1 | 3. VIAS control solenoid valve 2 |
| 4. EVAP canister purge volume control solenoid valve | 5. EVAP service port | 6. EVAP control system pressure sensor |
| 7. EVAP canister vent control valve | 8. EVAP canister | |
- ↶ : Vehicle front

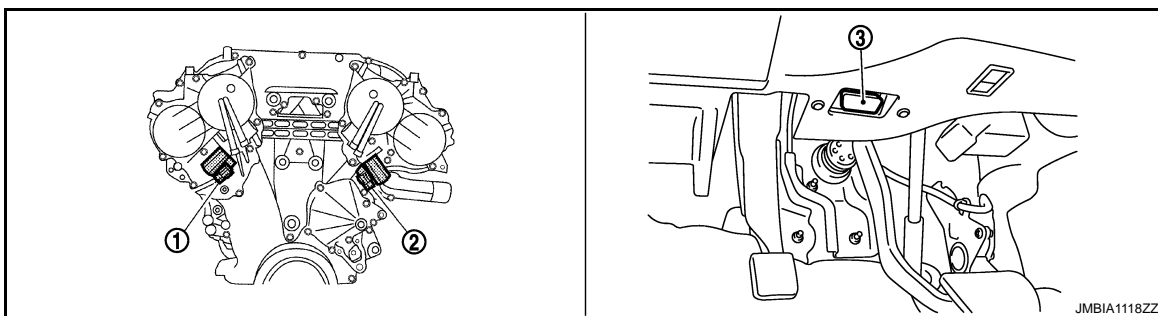

- | | | |
|--|--|------------------------|
| 1. Intake valve timing control solenoid valve (bank 1) | 2. Intake valve timing control solenoid valve (bank 2) | 3. Data link connector |
|--|--|------------------------|

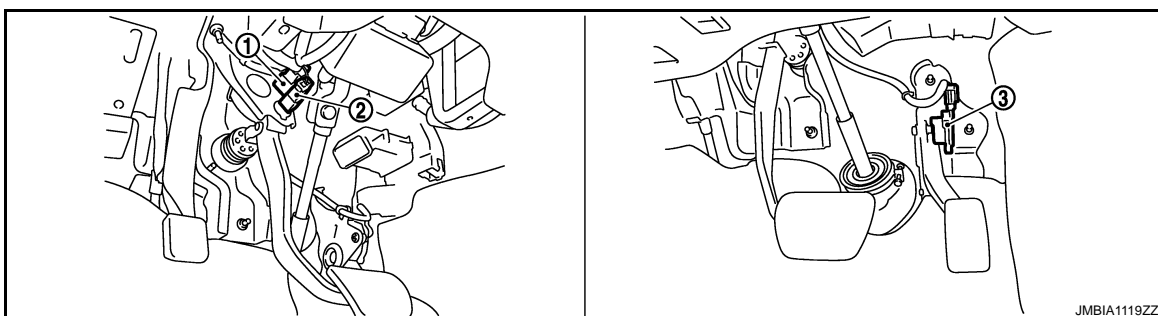

- | | | |
|---------------------|----------------------|--------------------------------------|
| 1. Stop lamp switch | 2. ASCD brake switch | 3. Accelerator pedal position sensor |
|---------------------|----------------------|--------------------------------------|

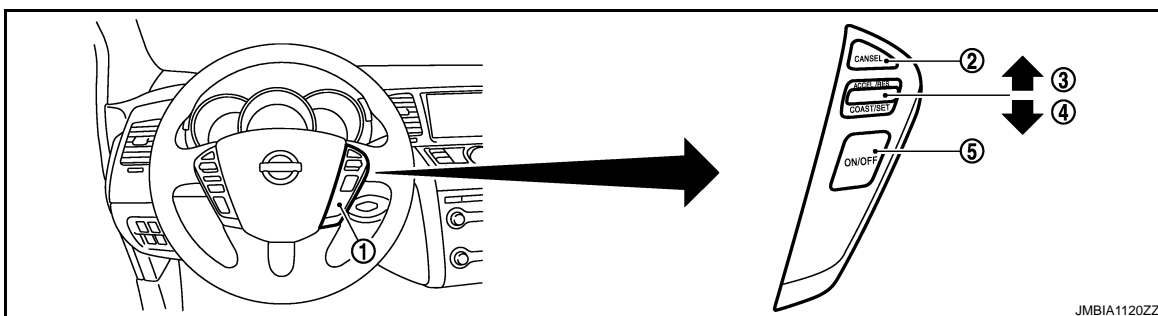

ELECTRIC IGNITION SYSTEM

[VQ35DE]

< FUNCTION DIAGNOSIS >

- | | | |
|-------------------------|------------------|-----------------------------|
| 1. ASCD steering switch | 2. CANCEL switch | 3. RESUME/ACCELERATE switch |
| 4. SET/COAST switch | 5. MAIN switch | |

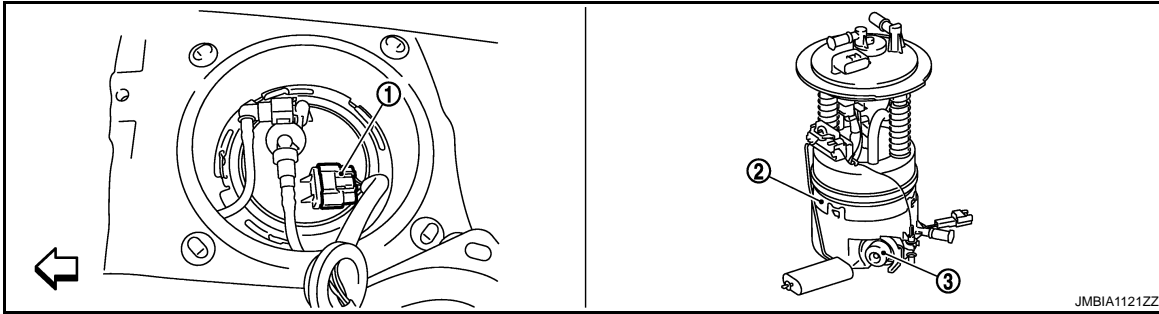

1. Fuel level sensor unit and fuel pump harness connector 2. Fuel level sensor unit and fuel pump 3. Fuel pressure regulator

← : Vehicle front

Component Description

INFOID:000000003387896

Component	Reference
Accelerator pedal position sensor	EC-413, "Description"
Camshaft position sensor (PHASE)	EC-264, "Description"
Crankshaft position sensor (POS)	EC-260, "Description"
Engine coolant temperature sensor	EC-170, "Description"
Ignition signal	EC-451, "Description"
Knock sensor	EC-257, "Description"
Mass air flow sensor	EC-154, "Description"
TCM	EC-350, "Description"
Throttle position sensor	EC-175, "Description"

AIR CONDITIONING CUT CONTROL

< FUNCTION DIAGNOSIS >

[VQ35DE]

AIR CONDITIONING CUT CONTROL

System Diagram

INFOID:000000003387897

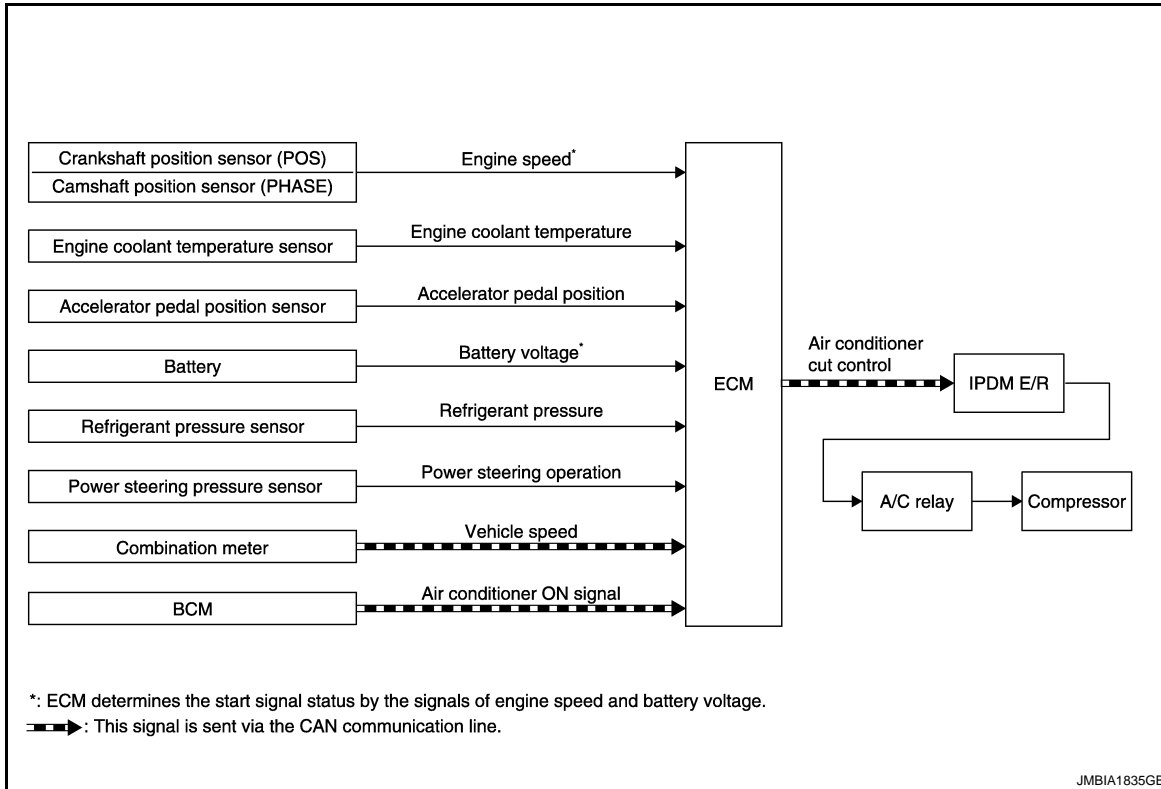

System Description

INFOID:000000003387898

INPUT/OUTPUT SIGNAL CHART

Sensor	Input signal to ECM	ECM function	Actuator
Crankshaft position sensor (POS) Camshaft position sensor (PHASE)	Engine speed*2	Air conditioner cut control	IPDM E/R ↓ Air conditioner relay ↓ Compressor
Engine coolant temperature sensor	Engine coolant temperature		
Accelerator pedal position sensor	Accelerator pedal position		
Battery	Battery voltage*2		
Refrigerant pressure sensor	Refrigerant pressure		
Power steering pressure sensor	Power steering operation		
Combination meter	Vehicle speed*1		
BCM	Air conditioner ON signal*1		

*1: This signal is sent to the ECM via the CAN communication line.

*2: ECM determines the start signal status by the signals of engine speed and battery voltage.

SYSTEM DESCRIPTION

This system improves engine operation when the air conditioner is used.

Under the following conditions, the air conditioner is turned OFF.

- When the accelerator pedal is fully depressed.
- When cranking the engine.
- At high engine speeds.
- When the engine coolant temperature becomes excessively high.
- When operating power steering during low engine speed or low vehicle speed.
- When engine speed is excessively low.
- When refrigerant pressure is excessively low or high.

AIR CONDITIONING CUT CONTROL

< FUNCTION DIAGNOSIS >

[VQ35DE]

Component Parts Location

INFOID:000000003573785

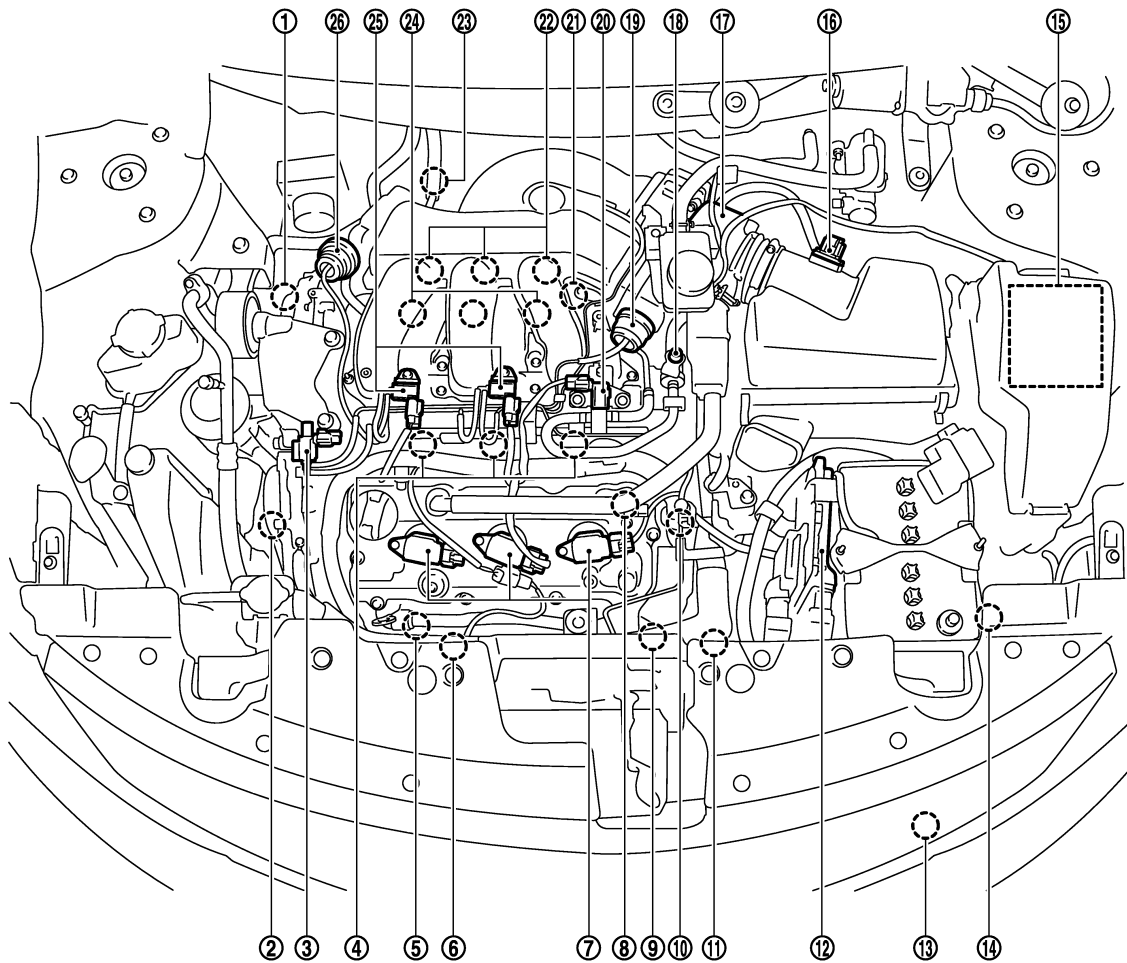

JMBIA1108ZZ

- | | | |
|---|--|--|
| 1. Intake valve timing control solenoid valve (bank 1) | 2. Intake valve timing control solenoid valve (bank 2) | 3. Electronic controlled engine mount control solenoid valve |
| 4. Fuel injector (bank 2) | 5. A/F sensor 1 (bank 2) | 6. Cooling fan motor-2 |
| 7. Ignition coil (with power transistor) and spark plug (bank 2) | 8. Camshaft position sensor (PHASE) (bank 2) | 9. Crankshaft position sensor (POS) |
| 10. Engine coolant temperature sensor | 11. Cooling fan motor-1 | 12. ECM |
| 13. Refrigerant pressure sensor | 14. Battery current sensor | 15. IPDM E/R |
| 16. Mass air flow sensor (with intake air temperature sensor) | 17. Electric throttle control actuator | 18. EVAP service port |
| 19. Power valve actuator 2 | 20. EVAP canister purge volume control solenoid valve | 21. Camshaft position sensor (PHASE) (bank 1) |
| 22. Ignition coil (with power transistor) and spark plug (bank 1) | 23. A/F sensor 1 (bank 1) | 24. Fuel injector (bank 1) |
| 25. VIAS control solenoid valve 1 and 2 | 26. Power valve actuator 1 | |

AIR CONDITIONING CUT CONTROL

< FUNCTION DIAGNOSIS >

[VQ35DE]

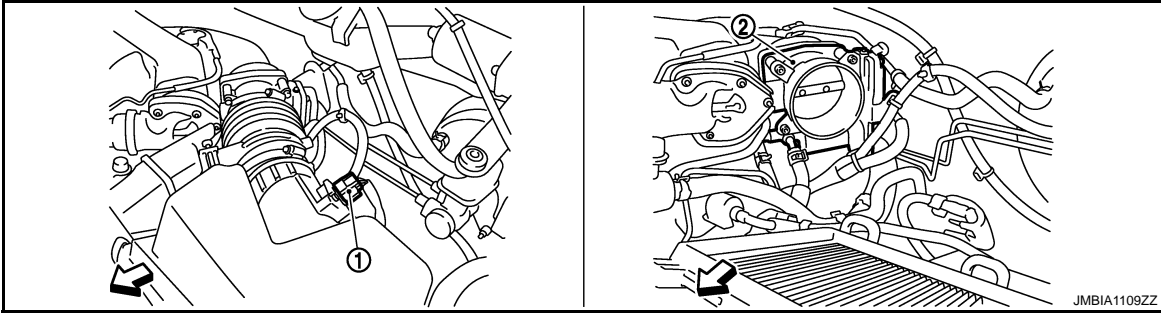

- 1. Mas air flow sensor (with intake air temperature sensor)
- 2. Electric throttle control actuator

← : Vehicle front

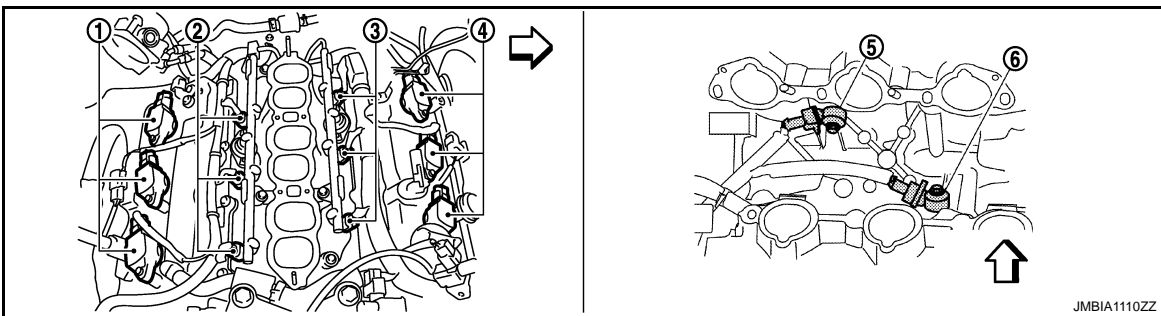

- 1. Ignition coil (with power transistor and spark plug (bank 1))
- 2. Fuel injector (bank 1)
- 3. Fuel injector (bank 2)
- 4. Ignition coil (with power transistor and spark plug (bank 2))
- 5. Knock sensor (bank 2)
- 6. Knock sensor (bank 1)

← : Vehicle front

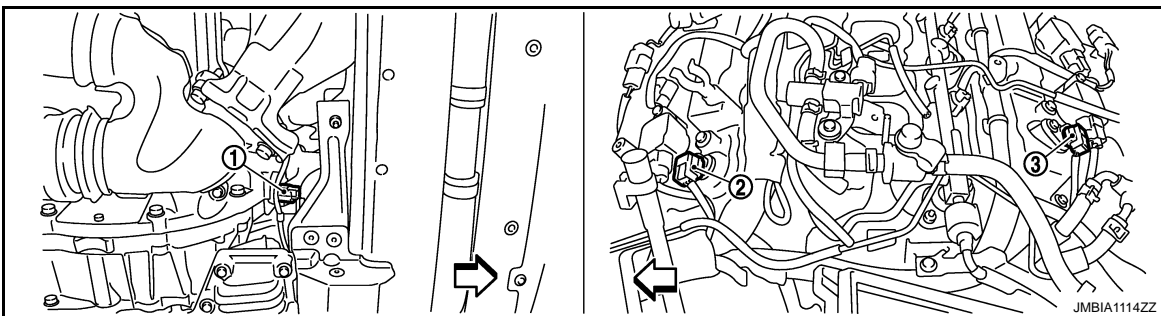

- 1. Crankshaft position sensor (POS)
- 2. Camshaft position sensor (PHASE) (bank 1)
- 3. Camshaft position sensor (PHASE) (bank 2)

← : Vehicle front

AIR CONDITIONING CUT CONTROL

< FUNCTION DIAGNOSIS >

[VQ35DE]

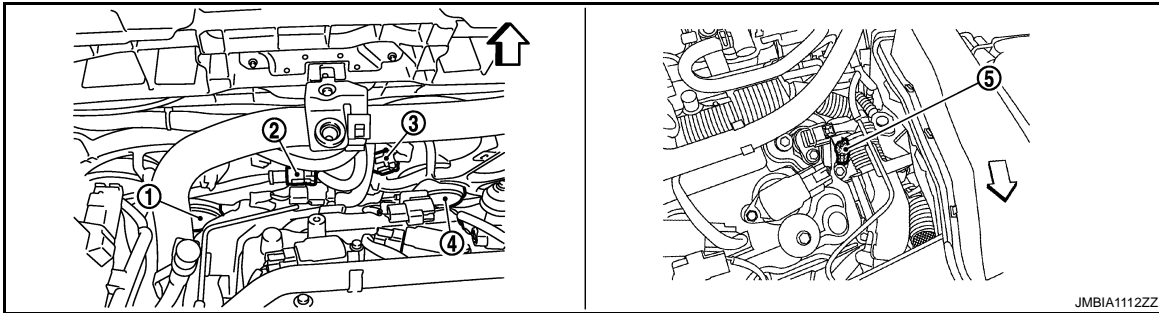

- 1. Cooling fan motor-1
- 2. Cooling fan motor-1 harness connector
- 3. Cooling fan motor-1 harness connector
- 4. Cooling fan motor-2
- 5. Engine coolant temperature sensor

↶ : Vehicle front

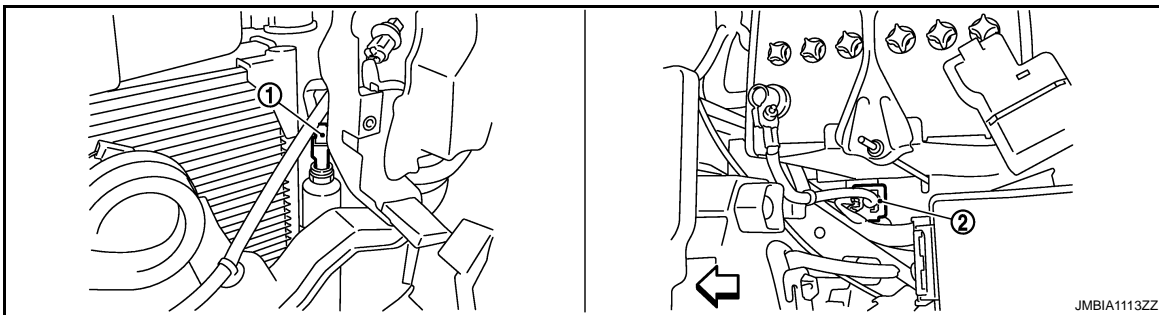

- 1. Refrigerant pressure sensor
- 2. Battery current sensor

↶ : Vehicle front

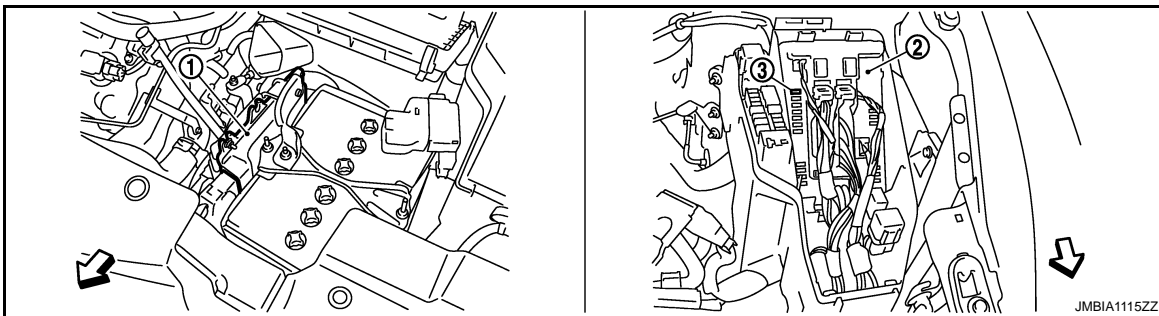

- 1. ECM
- 2. IPDM E/R
- 3. Fuel pump fuse

↶ : Vehicle front

A
EC
C
D
E
F
G
H
I
J
K
L
M
N
O
P

AIR CONDITIONING CUT CONTROL

< FUNCTION DIAGNOSIS >

[VQ35DE]

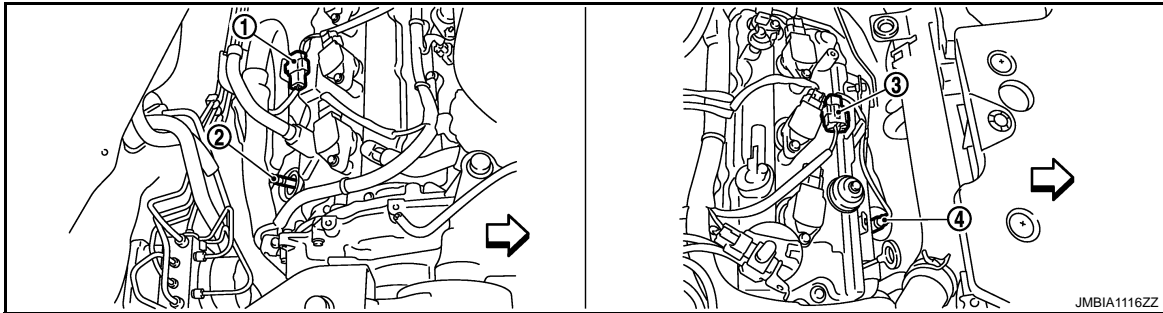
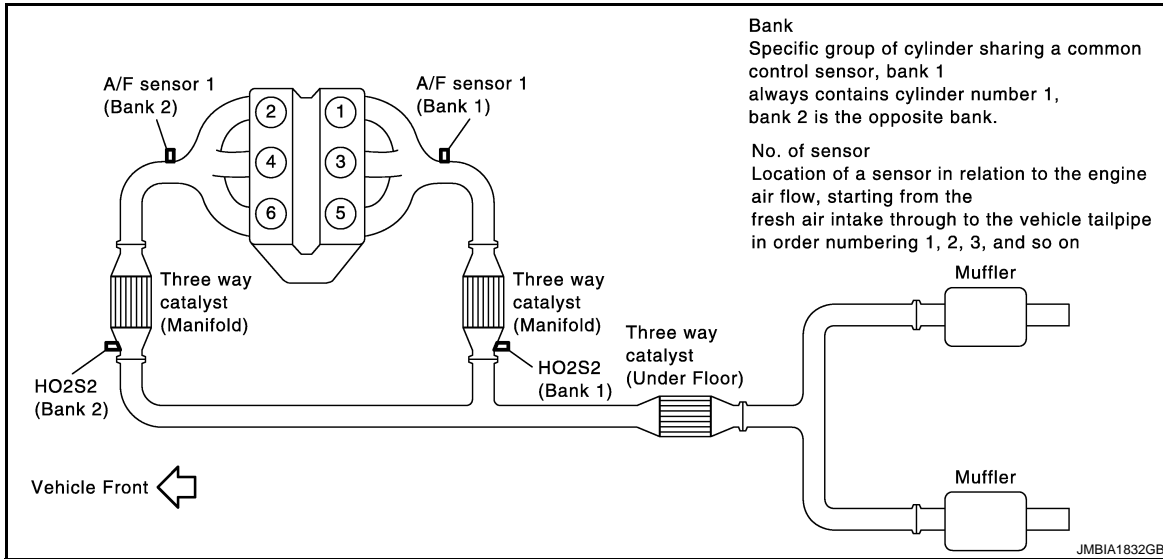

- 1. A/F sensor 1 (bank 1) harness connector
- 2. A/F sensor 1 (bank 1)
- 3. A/F sensor 1 (bank 2) harness connector

- 4. A/F sensor 1 (bank 2)

← : Vehicle front

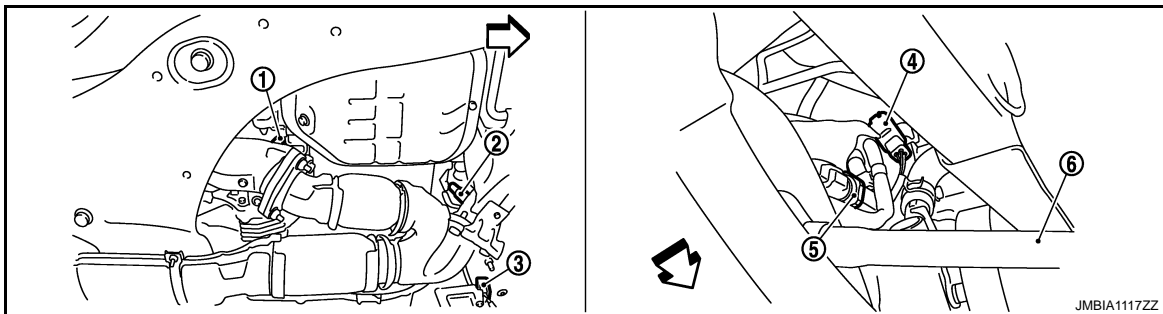

- 1. HO2S2 (bank 1)
- 2. HO2S2 (bank 2)
- 3. HO2S2 (bank 2) harness connector
- 4. HO2S2 (bank 1) harness connector
- 5. Power steering pressure sensor
- 6. Drive shaft (RH)

← : Vehicle front

AIR CONDITIONING CUT CONTROL

< FUNCTION DIAGNOSIS >

[VQ35DE]

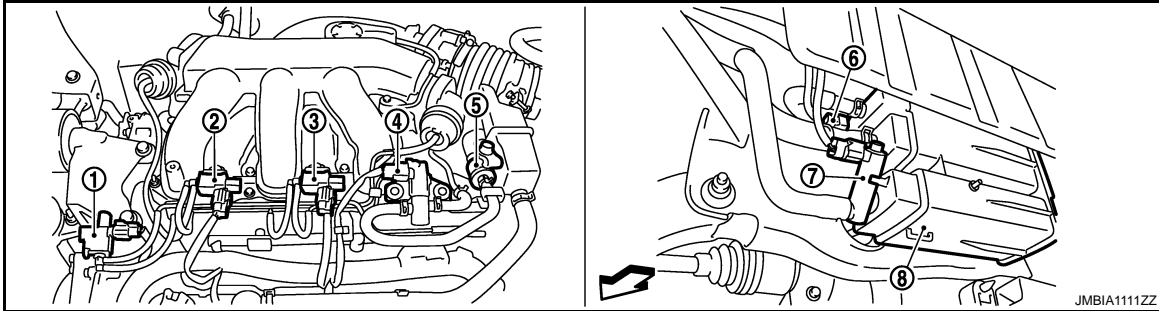

- 1. Electronic controlled engine mount control solenoid valve
- 2. VIAS control solenoid valve 1
- 3. VIAS control solenoid valve 2
- 4. EVAP canister purge volume control solenoid valve
- 5. EVAP service port
- 6. EVAP control system pressure sensor
- 7. EVAP canister vent control valve
- 8. EVAP canister

← : Vehicle front

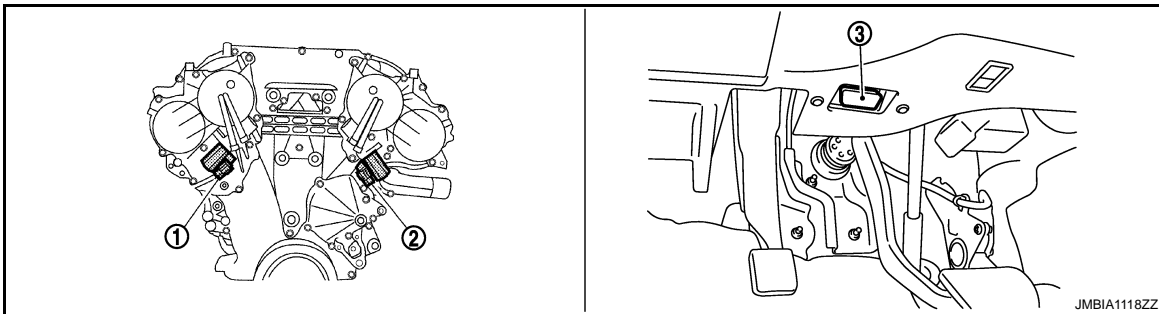

- 1. Intake valve timing control solenoid valve (bank 1)
- 2. Intake valve timing control solenoid valve (bank 2)
- 3. Data link connector

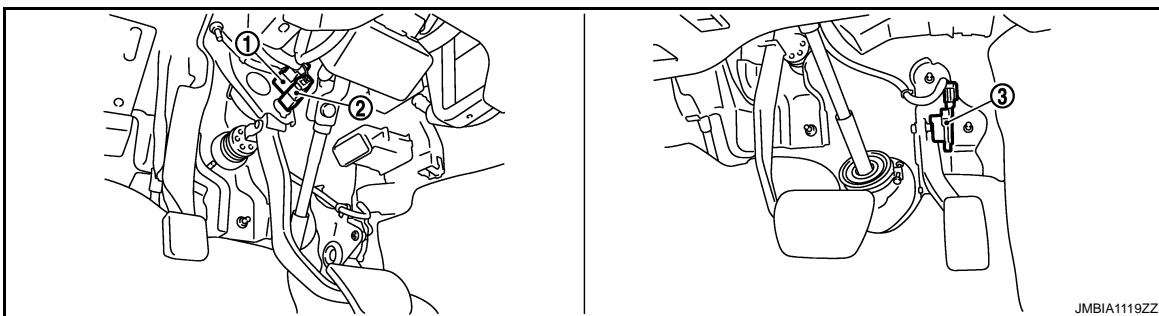

- 1. Stop lamp switch
- 2. ASCD brake switch
- 3. Accelerator pedal position sensor

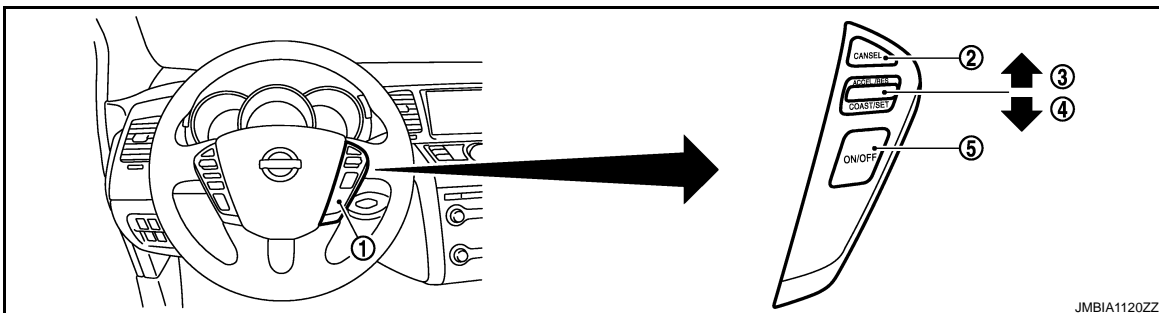

A
EC
C
D
E
F
G
H
I
J
K
L
M
N
O
P

AIR CONDITIONING CUT CONTROL

[VQ35DE]

< FUNCTION DIAGNOSIS >

- | | | |
|-------------------------|------------------|-----------------------------|
| 1. ASCD steering switch | 2. CANCEL switch | 3. RESUME/ACCELERATE switch |
| 4. SET/COAST switch | 5. MAIN switch | |

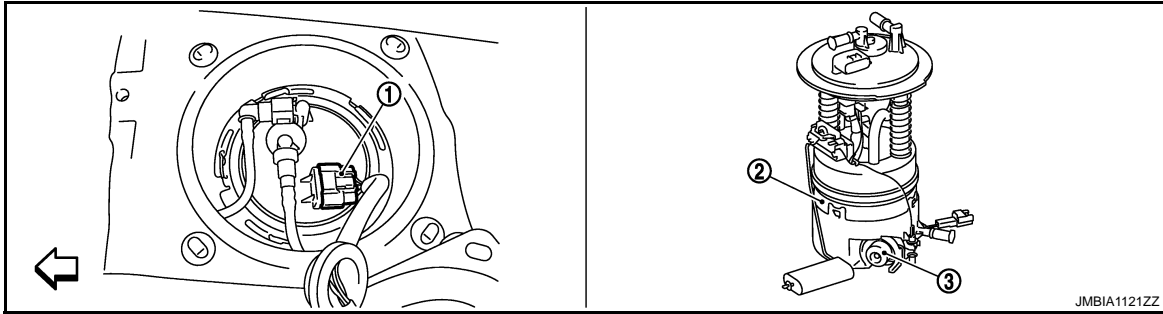

1. Fuel level sensor unit and fuel pump harness connector 2. Fuel level sensor unit and fuel pump 3. Fuel pressure regulator

← : Vehicle front

Component Description

INFOID:000000003387900

Component	Reference
Accelerator pedal position sensor	EC-413, "Description"
Camshaft position sensor (PHASE)	EC-264, "Description"
Crankshaft position sensor (POS)	EC-260, "Description"
Engine coolant temperature sensor	EC-170, "Description"
Power steering pressure sensor	EC-339, "Description"
Refrigerant pressure sensor	EC-463, "Description"

AUTOMATIC SPEED CONTROL DEVICE (ASCD)

< FUNCTION DIAGNOSIS >

[VQ35DE]

AUTOMATIC SPEED CONTROL DEVICE (ASCD)

System Diagram

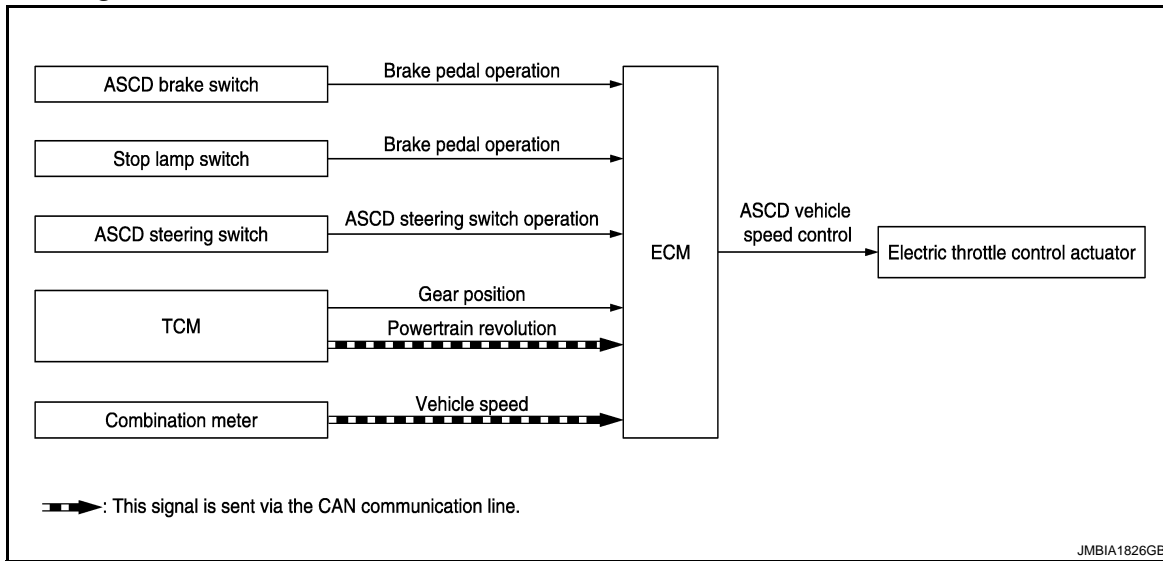

System Description

INFOID:000000003387902

INPUT/OUTPUT SIGNAL CHART

Sensor	Input signal to ECM	ECM function	Actuator
ASCD brake switch	Brake pedal operation	ASCD vehicle speed control	Electric throttle control actuator
Stop lamp switch	Brake pedal operation		
ASCD steering switch	ASCD steering switch operation		
TCM	Gear position		
	Powertrain revolution*		
Combination meter	Vehicle speed*		

*: This signal is sent to the ECM via the CAN communication line

BASIC ASCD SYSTEM

Refer to Owner's Manual for ASCD operating instructions.

Automatic Speed Control Device (ASCD) allows a driver to keep vehicle at predetermined constant speed without depressing accelerator pedal. Driver can set vehicle speed in advance between approximately 40 km/h (25 MPH) and 144 km/h (89 MPH).

ECM controls throttle angle of electric throttle control actuator to regulate engine speed.

Operation status of ASCD is indicated by CRUISE on combination meter. If any malfunction occurs in the ASCD system, it automatically deactivates control.

NOTE:

Always drive vehicle in a safe manner according to traffic conditions and obey all traffic laws.

SET OPERATION

Press MAIN switch. (The CRUISE on combination meter illuminates.)

When vehicle speed reaches a desired speed between approximately 40 km/h (25 MPH) and 144 km/h (89 MPH), press SET/COAST switch.

ACCELERATE OPERATION

If the RESUME/ACCELERATE switch is pressed during cruise control driving, increase the vehicle speed until the switch is released or vehicle speed reaches maximum speed controlled by the system. And then ASCD will maintain the new set speed.

CANCEL OPERATION

When any of following conditions exist, cruise operation will be canceled.

AUTOMATIC SPEED CONTROL DEVICE (ASCD)

[VQ35DE]

< FUNCTION DIAGNOSIS >

- CANCEL switch is pressed
- More than 2 switches on ASCD steering switch are pressed at the same time (Set speed will be cleared)
- Brake pedal is depressed
- Selector lever position changed to N, P or R
- Vehicle speed decreased to 13 km/h (8 MPH) lower than the set speed
- TCS system is operated
- CVT control system has a malfunction. Refer to [EC-388. "Description"](#).
- Engine coolant temperature is slightly higher than the normal operating temperature

When the ECM detects any of the following conditions, the ECM will cancel the cruise operation and inform the driver by blinking indicator lamp.

- Malfunction for some self-diagnoses regarding ASCD control: CRUISE will blink quickly.

If MAIN switch is turned to OFF while ASCD is activated, all of ASCD operations will be canceled and vehicle speed memory will be erased.

COAST OPERATION

When the SET/COAST switch is pressed during cruise control driving, decrease vehicle set speed until the switch is released. And then ASCD will maintain the new set speed.

RESUME OPERATION

When the RESUME/ACCELERATE switch is pressed after canceling operation other than pressing the MAIN switch is performed, vehicle speed will return to last set speed. To resume vehicle set speed, vehicle condition must meet following conditions.

- Brake pedal is released
- Selector lever position is other than P and N
- Vehicle speed is greater than 40 km/h (25 MPH) and less than 144 km/h (89 MPH)

AUTOMATIC SPEED CONTROL DEVICE (ASCD)

< FUNCTION DIAGNOSIS >

[VQ35DE]

Component Parts Location

INFOID:000000003573786

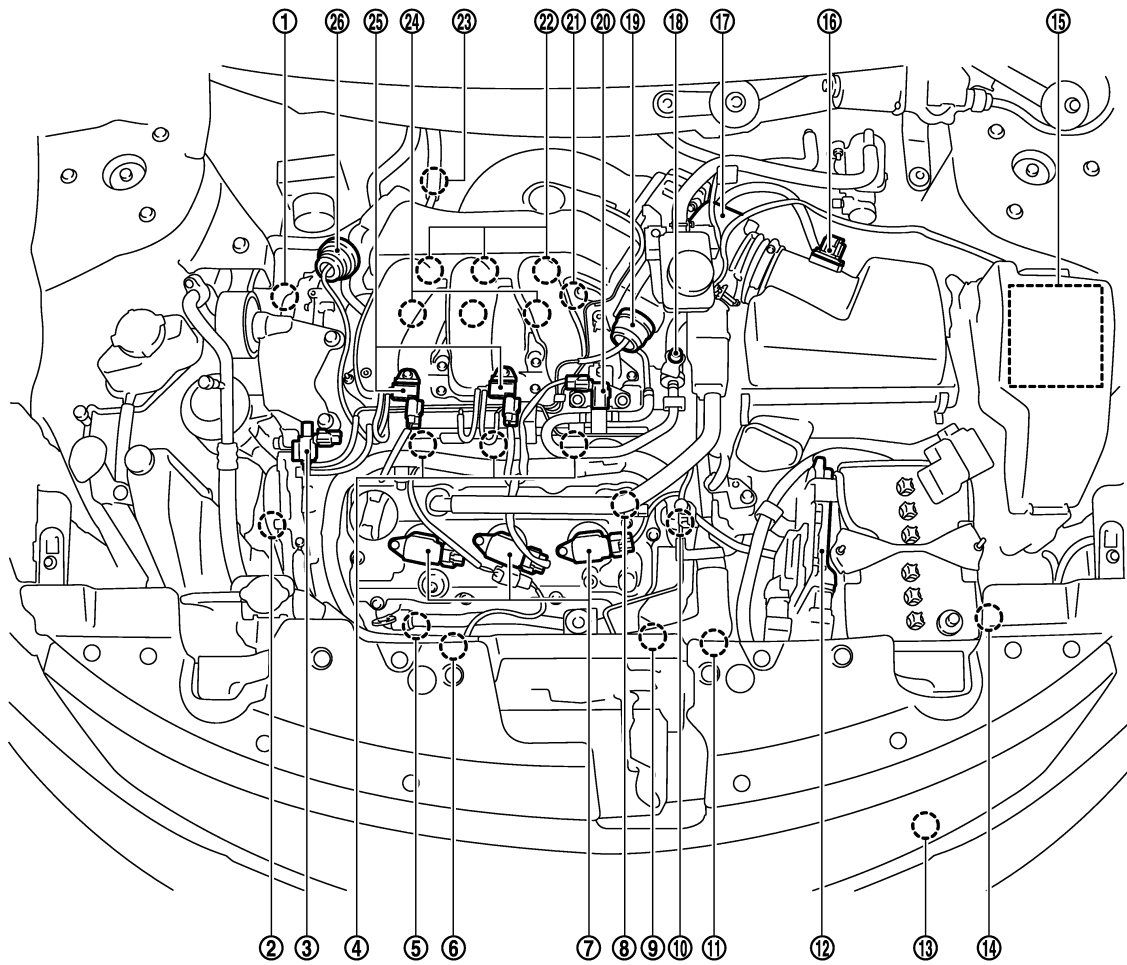

JMBIA1108ZZ

- | | | |
|---|--|--|
| 1. Intake valve timing control solenoid valve (bank 1) | 2. Intake valve timing control solenoid valve (bank 2) | 3. Electronic controlled engine mount control solenoid valve |
| 4. Fuel injector (bank 2) | 5. A/F sensor 1 (bank 2) | 6. Cooling fan motor-2 |
| 7. Ignition coil (with power transistor) and spark plug (bank 2) | 8. Camshaft position sensor (PHASE) (bank 2) | 9. Crankshaft position sensor (POS) |
| 10. Engine coolant temperature sensor | 11. Cooling fan motor-1 | 12. ECM |
| 13. Refrigerant pressure sensor | 14. Battery current sensor | 15. IPDM E/R |
| 16. Mass air flow sensor (with intake air temperature sensor) | 17. Electric throttle control actuator | 18. EVAP service port |
| 19. Power valve actuator 2 | 20. EVAP canister purge volume control solenoid valve | 21. Camshaft position sensor (PHASE) (bank 1) |
| 22. Ignition coil (with power transistor) and spark plug (bank 1) | 23. A/F sensor 1 (bank 1) | 24. Fuel injector (bank 1) |
| 25. VIAS control solenoid valve 1 and 2 | 26. Power valve actuator 1 | |

AUTOMATIC SPEED CONTROL DEVICE (ASCD)

< FUNCTION DIAGNOSIS >

[VQ35DE]

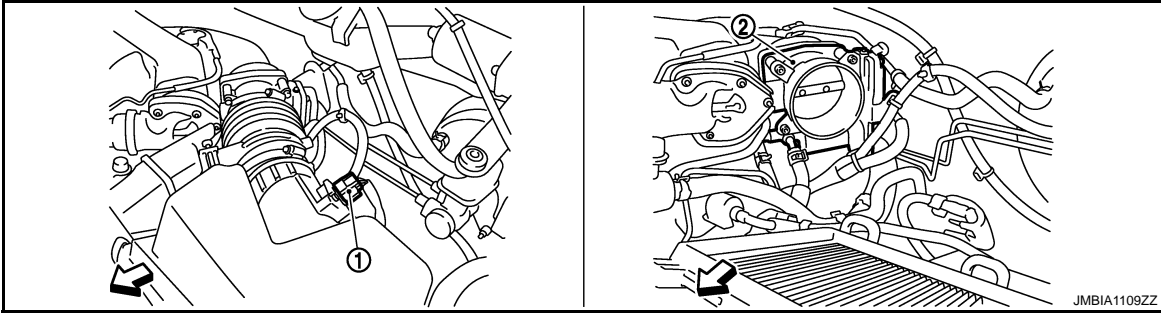

- 1. Mas air flow sensor (with intake air temperature sensor)
- 2. Electric throttle control actuator

← : Vehicle front

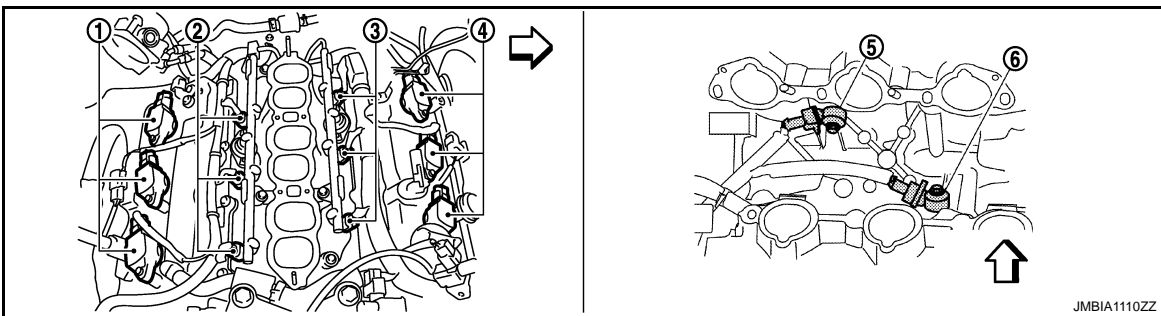

- 1. Ignition coil (with power transistor and spark plug (bank 1))
- 2. Fuel injector (bank 1)
- 3. Fuel injector (bank 2)
- 4. Ignition coil (with power transistor and spark plug (bank 2))
- 5. Knock sensor (bank 2)
- 6. Knock sensor (bank 1)

← : Vehicle front

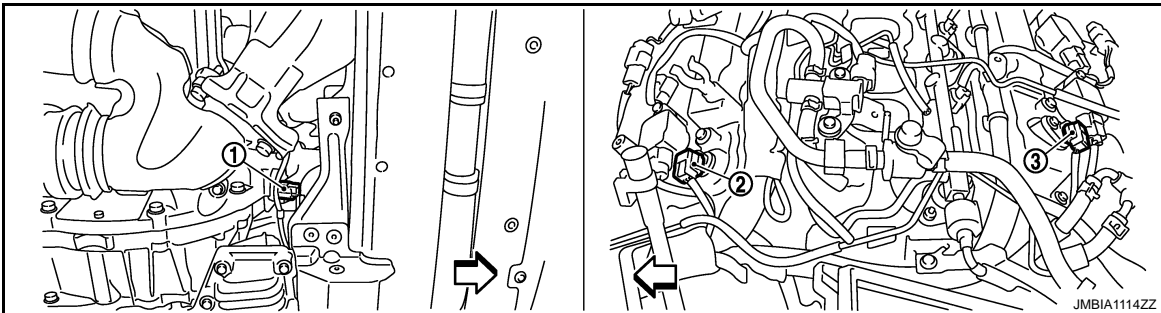

- 1. Crankshaft position sensor (POS)
- 2. Camshaft position sensor (PHASE) (bank 1)
- 3. Camshaft position sensor (PHASE) (bank 2)

← : Vehicle front

AUTOMATIC SPEED CONTROL DEVICE (ASCD)

< FUNCTION DIAGNOSIS >

[VQ35DE]

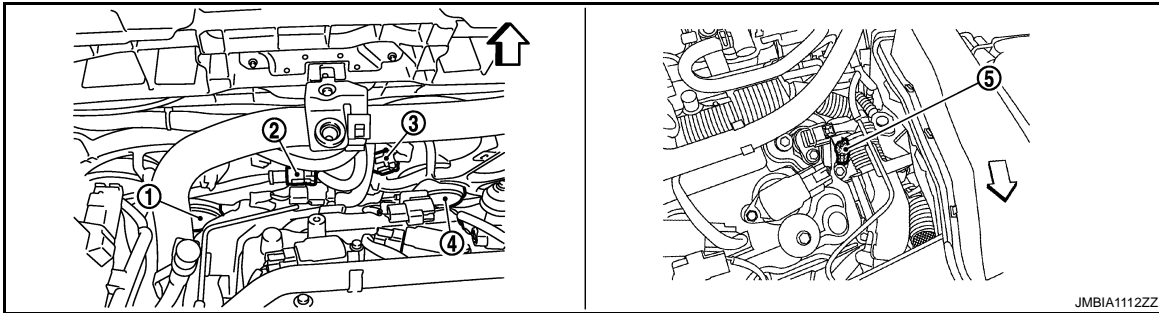

- 1. Cooling fan motor-1
- 2. Cooling fan motor-1 harness connector
- 3. Cooling fan motor-1 harness connector
- 4. Cooling fan motor-2
- 5. Engine coolant temperature sensor

↶ : Vehicle front

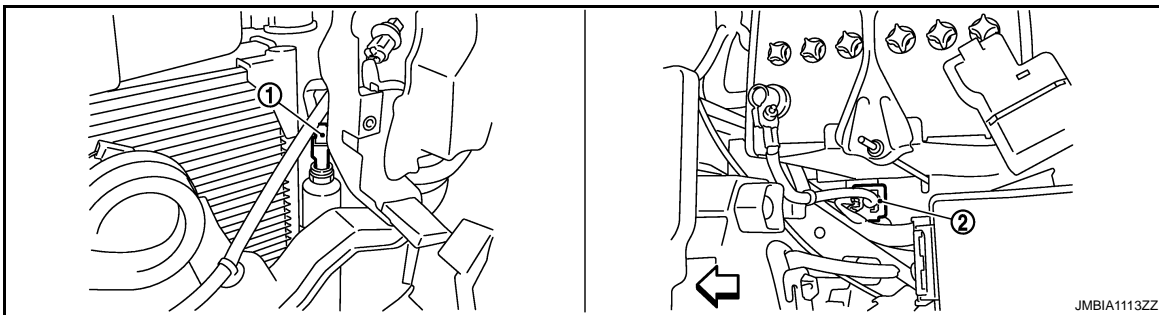

- 1. Refrigerant pressure sensor
- 2. Battery current sensor

↶ : Vehicle front

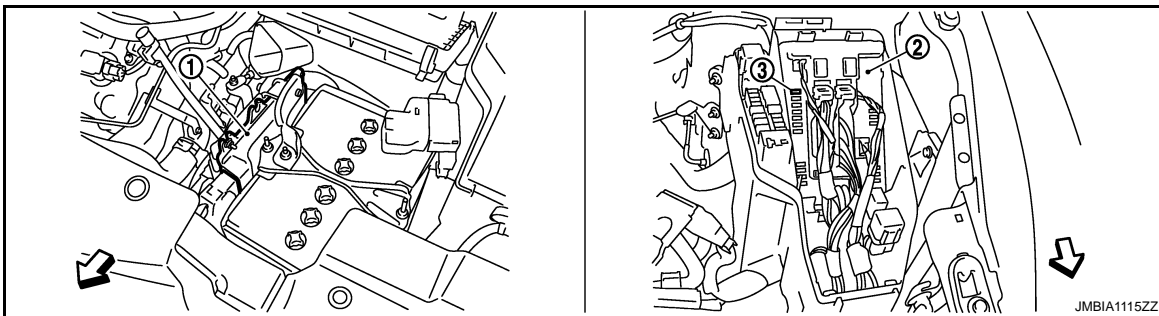

- 1. ECM
- 2. IPDM E/R
- 3. Fuel pump fuse

↶ : Vehicle front

A
EC
C
D
E
F
G
H
I
J
K
L
M
N
O
P

AUTOMATIC SPEED CONTROL DEVICE (ASCD)

< FUNCTION DIAGNOSIS >

[VQ35DE]

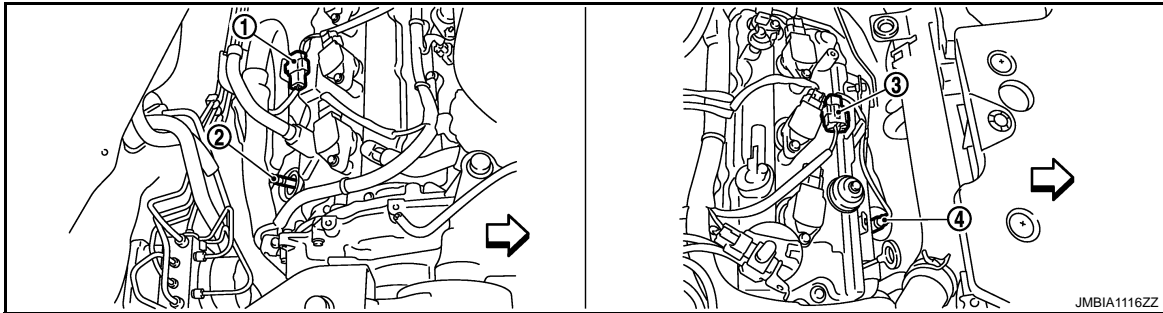
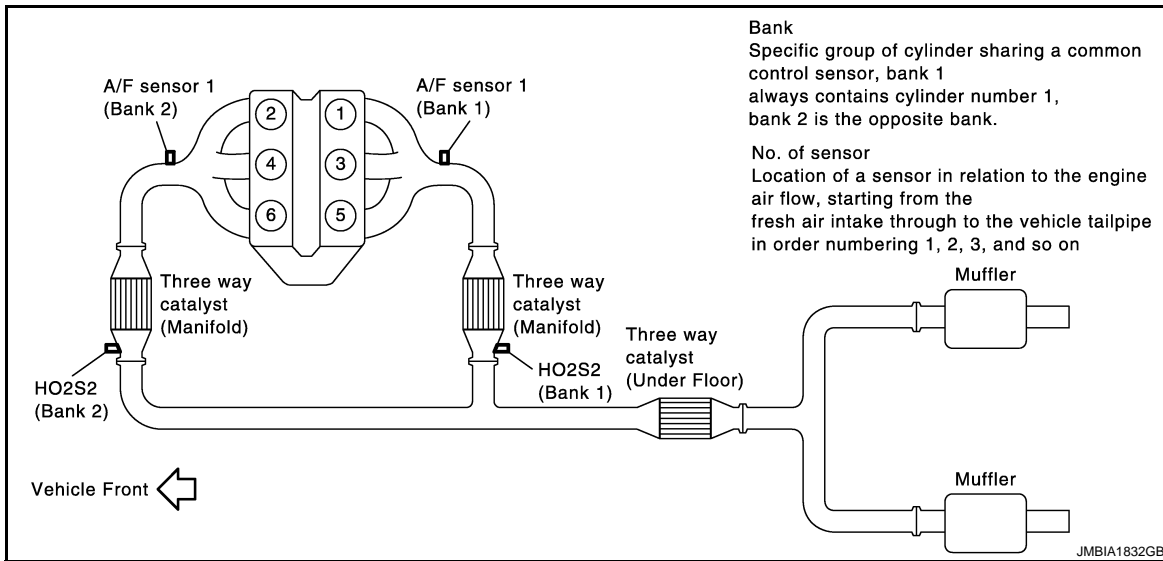

- | | | |
|--|--------------------------|--|
| 1. A/F sensor 1 (bank 1) harness connector | 2. A/F sensor 1 (bank 1) | 3. A/F sensor 1 (bank 2) harness connector |
| 4. A/F sensor 1 (bank 2) | | |
- ← : Vehicle front

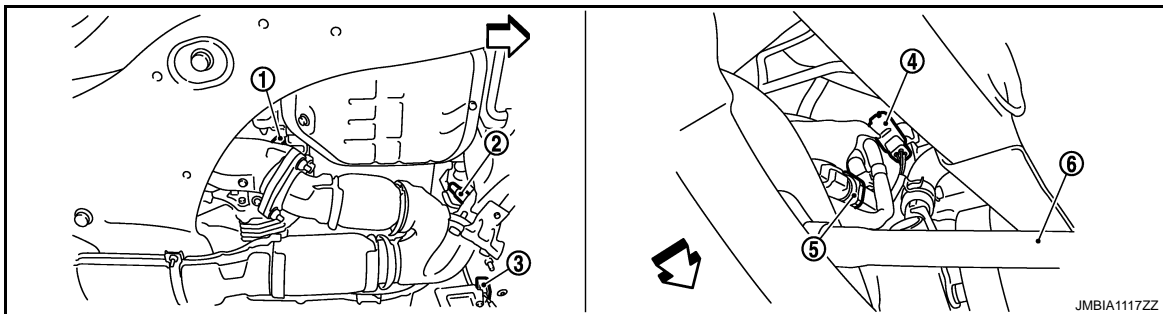

- | | | |
|-------------------------------------|-----------------------------------|-------------------------------------|
| 1. HO2S2 (bank 1) | 2. HO2S2 (bank 2) | 3. HO2S2 (bank 2) harness connector |
| 4. HO2S2 (bank 1) harness connector | 5. Power steering pressure sensor | 6. Drive shaft (RH) |
- ← : Vehicle front

AUTOMATIC SPEED CONTROL DEVICE (ASCD)

< FUNCTION DIAGNOSIS >

[VQ35DE]

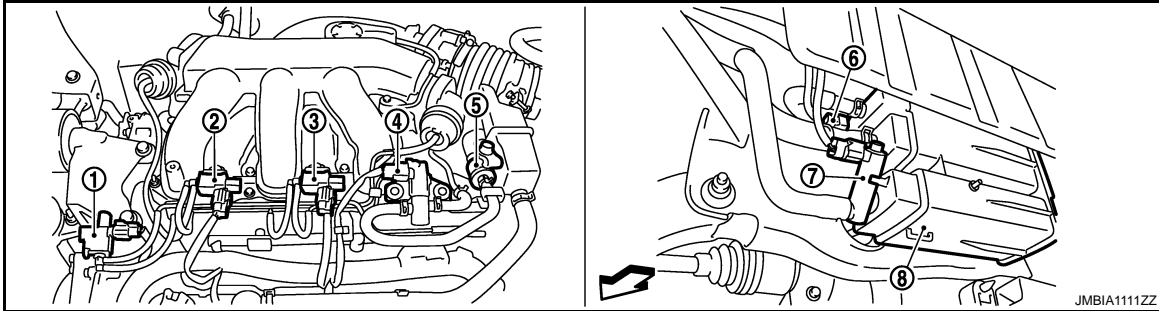

- 1. Electronic controlled engine mount control solenoid valve
- 2. VIAS control solenoid valve 1
- 3. VIAS control solenoid valve 2
- 4. EVAP canister purge volume control solenoid valve
- 5. EVAP service port
- 6. EVAP control system pressure sensor
- 7. EVAP canister vent control valve
- 8. EVAP canister

← : Vehicle front

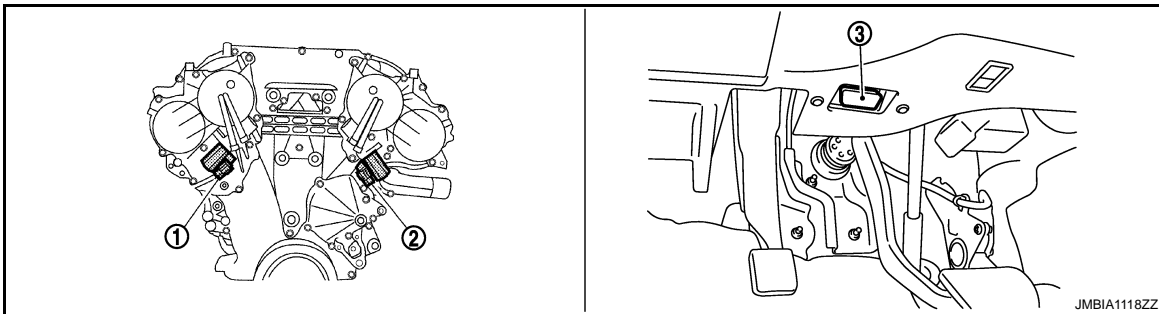

- 1. Intake valve timing control solenoid valve (bank 1)
- 2. Intake valve timing control solenoid valve (bank 2)
- 3. Data link connector

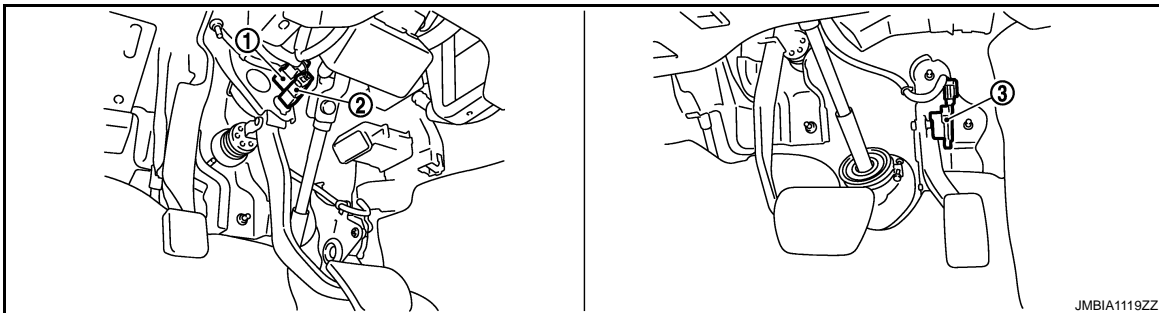

- 1. Stop lamp switch
- 2. ASCD brake switch
- 3. Accelerator pedal position sensor

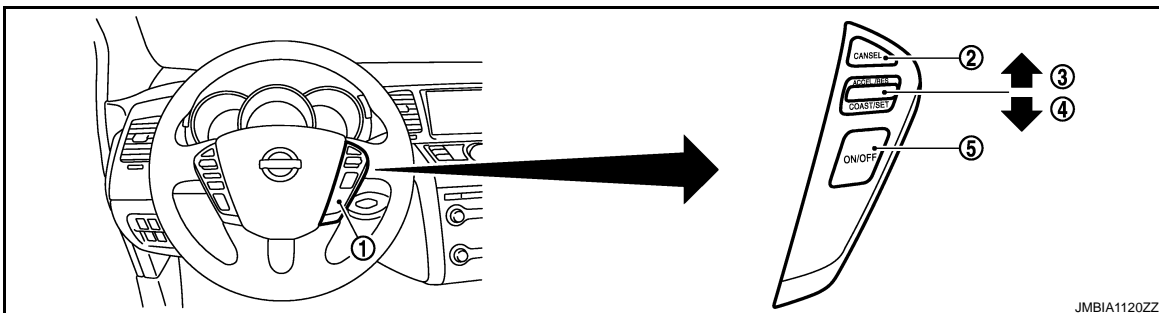

A
EC
C
D
E
F
G
H
I
J
K
L
M
N
O
P

AUTOMATIC SPEED CONTROL DEVICE (ASCD)

< FUNCTION DIAGNOSIS >

[VQ35DE]

- | | | |
|-------------------------|------------------|-----------------------------|
| 1. ASCD steering switch | 2. CANCEL switch | 3. RESUME/ACCELERATE switch |
| 4. SET/COAST switch | 5. MAIN switch | |

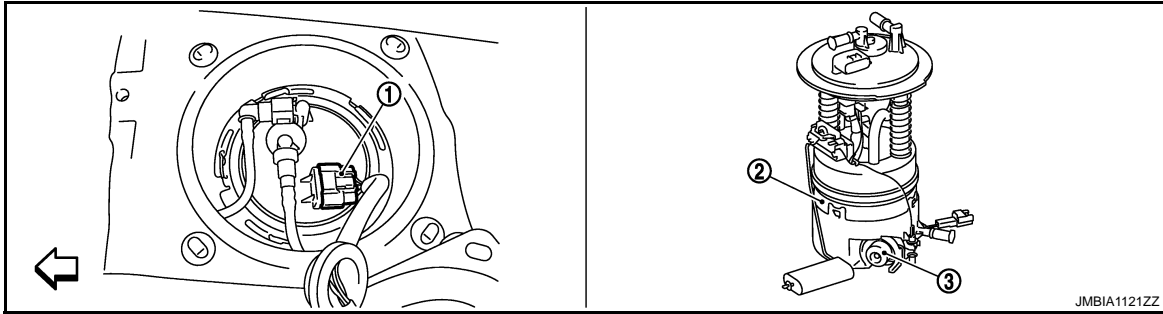

1. Fuel level sensor unit and fuel pump harness connector 2. Fuel level sensor unit and fuel pump 3. Fuel pressure regulator

← : Vehicle front

Component Description

INFOID:000000003387904

Component	Reference
ASCD brake switch	EC-380. "Description"
ASCD indicator	EC-433. "Description"
ASCD steering switch	EC-377. "Description"
Electric throttle control actuator	EC-411. "Description"
Stop lamp switch	EC-399. "Description"

CAN COMMUNICATION

System Description

INFOID:000000003387905

CAN (Controller Area Network) is a serial communication line for real time application. It is an on-vehicle multiplex communication line with high data communication speed and excellent error detection ability. Many electronic control units are equipped onto a vehicle, and each control unit shares information and links with other control units during operation (not independent). In CAN communication, control units are connected with 2 communication lines (CAN H line, CAN L line) allowing a high rate of information transmission with less wiring. Each control unit transmits/receives data but selectively reads required data only.

Refer to [LAN-25. "CAN Communication Signal Chart"](#), about CAN communication for detail.

A

EC

C

D

E

F

G

H

I

J

K

L

M

N

O

P

COOLING FAN CONTROL

< FUNCTION DIAGNOSIS >

[VQ35DE]

COOLING FAN CONTROL

System Diagram

INFOID:000000003387906

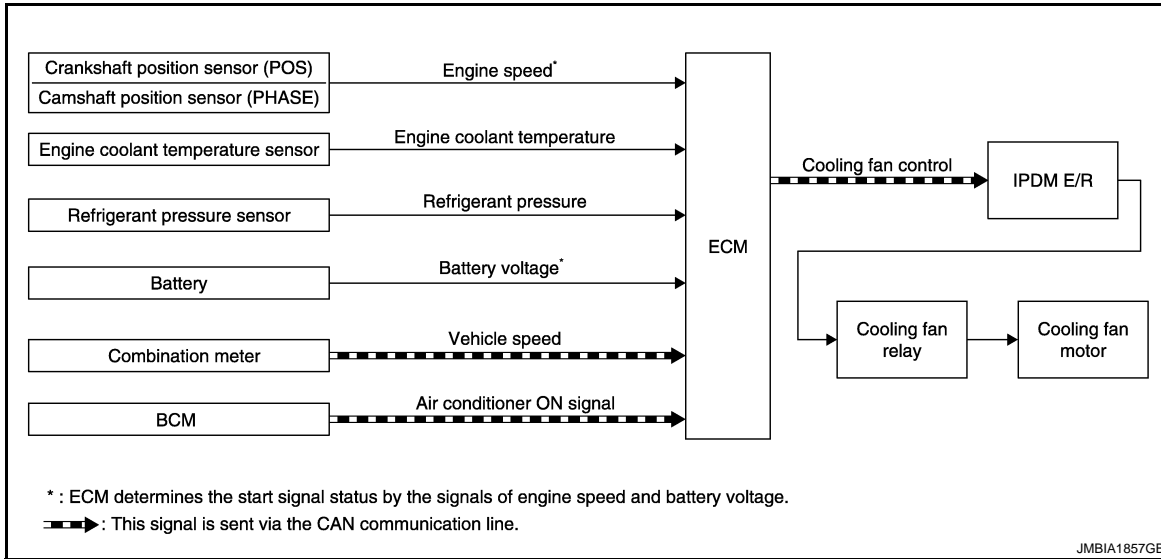

System Description

INFOID:000000003387907

INPUT/OUTPUT SIGNAL CHART

Sensor	Input signal to ECM	ECM function	Actuator
Crankshaft position sensor (POS) Camshaft position sensor (PHASE)	Engine speed* ¹ Piston position	Cooling fan control	IPDM E/R ↓ Cooling fan relay ↓ Cooling fan motor
Engine coolant temperature sensor	Engine coolant temperature		
Refrigerant pressure sensor	Refrigerant pressure		
Battery	Battery voltage* ¹		
Combination meter	Vehicle speed* ²		
BCM	Air conditioner ON signal* ²		

*1: The ECM determines the start signal status by the signals of engine speed and battery voltage.

*2: This signal is sent to ECM via the CAN communication line.

SYSTEM DESCRIPTION

The ECM controls the cooling fan corresponding to the vehicle speed, engine coolant temperature, refrigerant pressure, and air conditioner ON signal. The control system has 4-step control [HIGH/MIDDLE/LOW/OFF].

COOLING FAN CONTROL

< FUNCTION DIAGNOSIS >

[VQ35DE]

Cooling Fan Operation

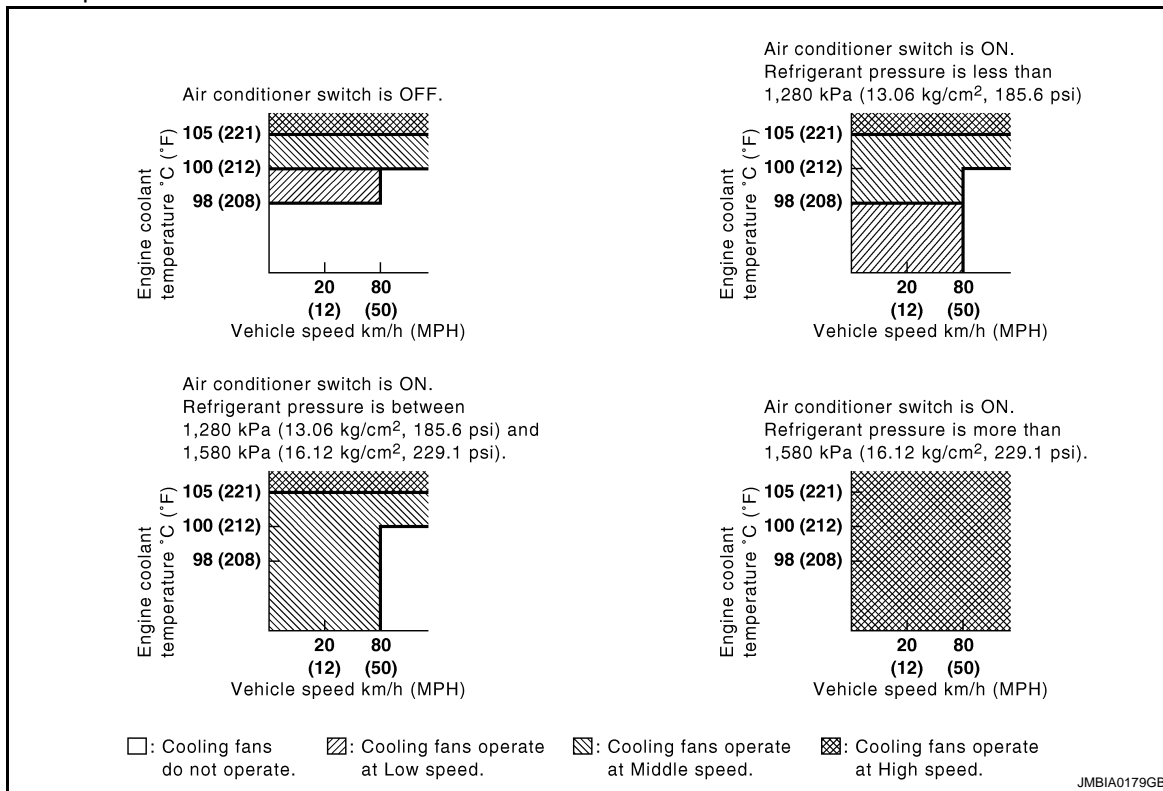

Cooling Fan Relay Operation

The ECM controls cooling fan relays in the IPDM E/R through CAN communication line.

Cooling fan speed	Cooling fan relay		
	1	2	3
Stop (OFF)	OFF	OFF	OFF
Low (LOW)	ON	OFF	OFF
Middle (MID)	OFF	ON	OFF
High (HI)	OFF	ON	ON

COOLING FAN CONTROL

< FUNCTION DIAGNOSIS >

[VQ35DE]

Component Parts Location

INFOID:000000003573788

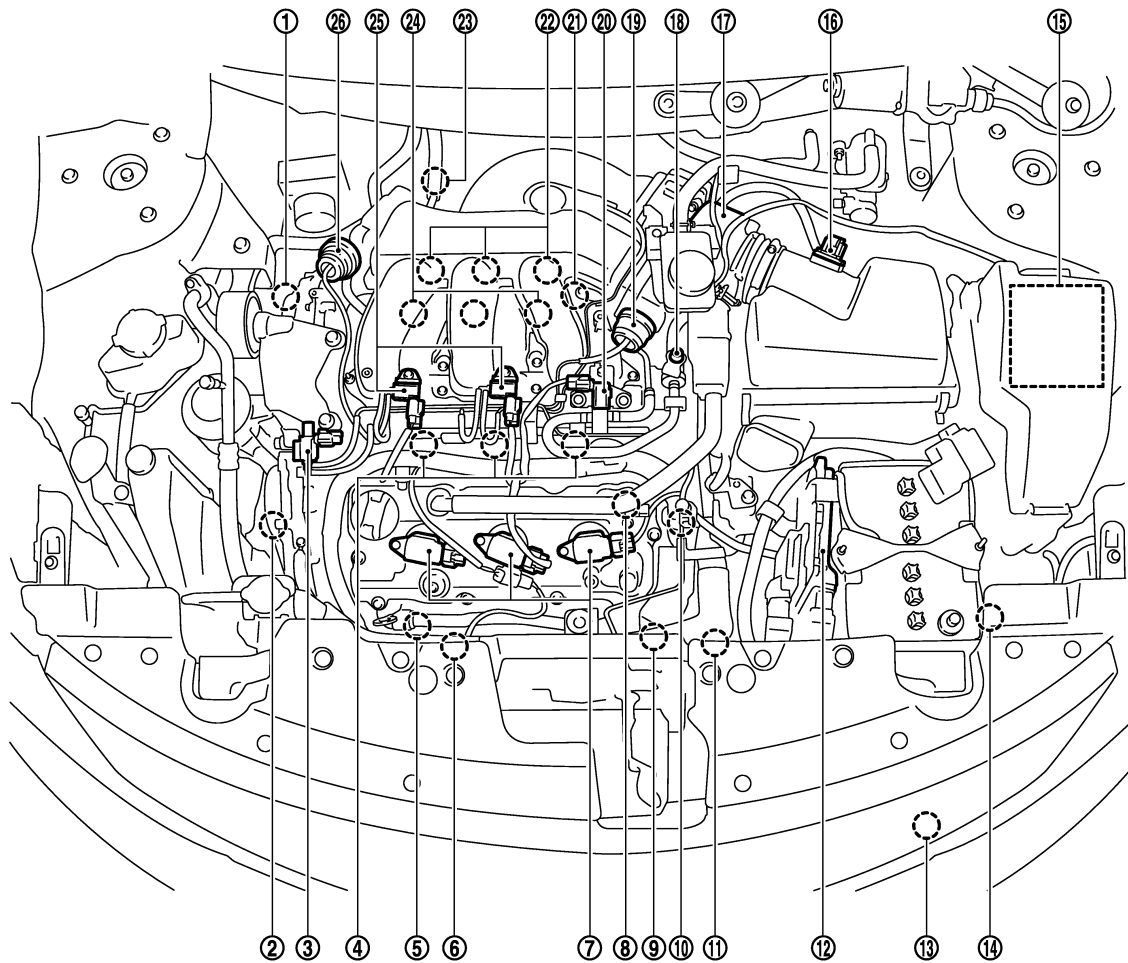

JMBIA1108ZZ

- | | | |
|---|--|--|
| 1. Intake valve timing control solenoid valve (bank 1) | 2. Intake valve timing control solenoid valve (bank 2) | 3. Electronic controlled engine mount control solenoid valve |
| 4. Fuel injector (bank 2) | 5. A/F sensor 1 (bank 2) | 6. Cooling fan motor-2 |
| 7. Ignition coil (with power transistor) and spark plug (bank 2) | 8. Camshaft position sensor (PHASE) (bank 2) | 9. Crankshaft position sensor (POS) |
| 10. Engine coolant temperature sensor | 11. Cooling fan motor-1 | 12. ECM |
| 13. Refrigerant pressure sensor | 14. Battery current sensor | 15. IPDM E/R |
| 16. Mass air flow sensor (with intake air temperature sensor) | 17. Electric throttle control actuator | 18. EVAP service port |
| 19. Power valve actuator 2 | 20. EVAP canister purge volume control solenoid valve | 21. Camshaft position sensor (PHASE) (bank 1) |
| 22. Ignition coil (with power transistor) and spark plug (bank 1) | 23. A/F sensor 1 (bank 1) | 24. Fuel injector (bank 1) |
| 25. VIAS control solenoid valve 1 and 2 | 26. Power valve actuator 1 | |

COOLING FAN CONTROL

< FUNCTION DIAGNOSIS >

[VQ35DE]

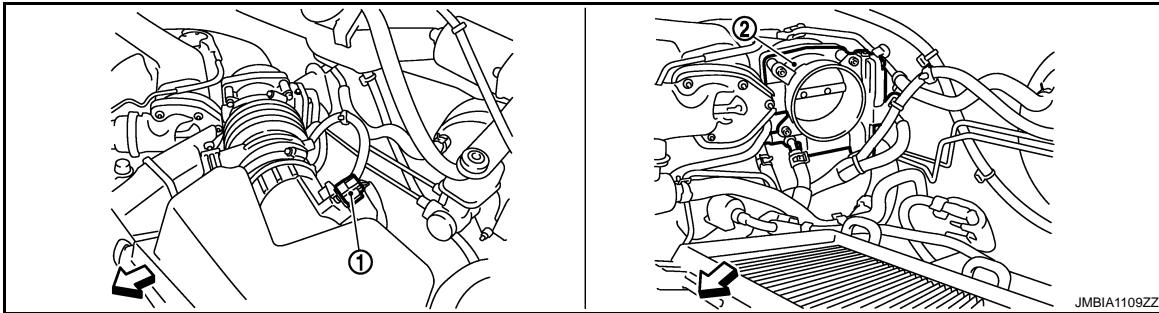

- 1. Maf air flow sensor (with intake air temperature sensor)
- 2. Electric throttle control actuator

← : Vehicle front

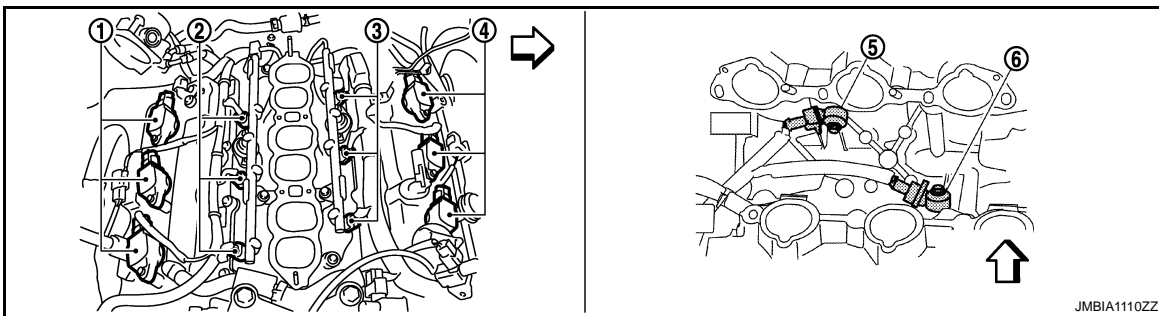

- 1. Ignition coil (with power transistor and spark plug (bank 1))
- 2. Fuel injector (bank 1)
- 3. Fuel injector (bank 2)
- 4. Ignition coil (with power transistor and spark plug (bank 2))
- 5. Knock sensor (bank 2)
- 6. Knock sensor (bank 1)

← : Vehicle front

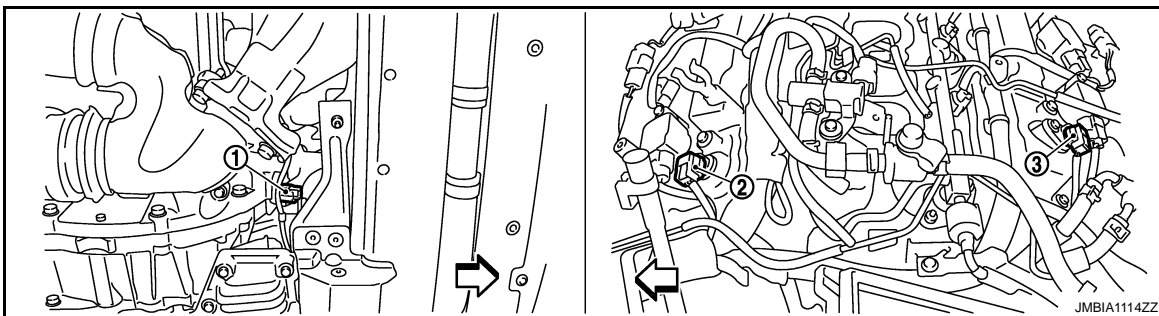

- 1. Crankshaft position sensor (POS)
- 2. Camshaft position sensor (PHASE) (bank 1)
- 3. Camshaft position sensor (PHASE) (bank 2)

← : Vehicle front

A
EC
C
D
E
F
G
H
I
J
K
L
M
N
O
P

COOLING FAN CONTROL

< FUNCTION DIAGNOSIS >

[VQ35DE]

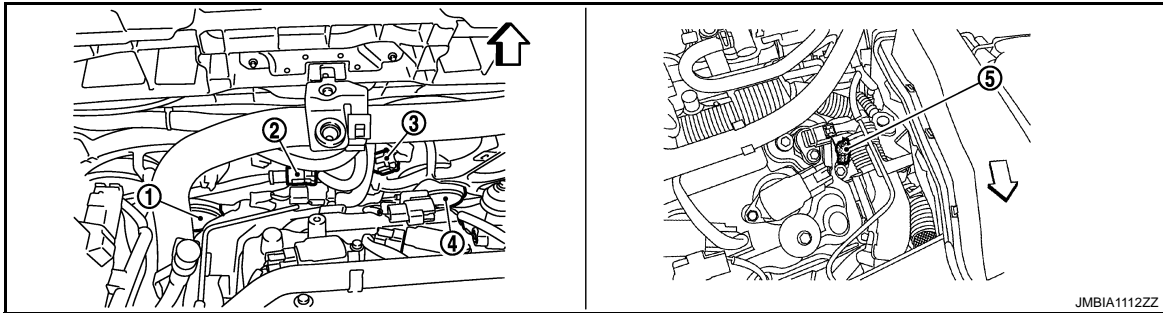

- 1. Cooling fan motor-1
- 2. Cooling fan motor-1 harness connector
- 3. Cooling fan motor-1 harness connector
- 4. Cooling fan motor-2
- 5. Engine coolant temperature sensor

↶ : Vehicle front

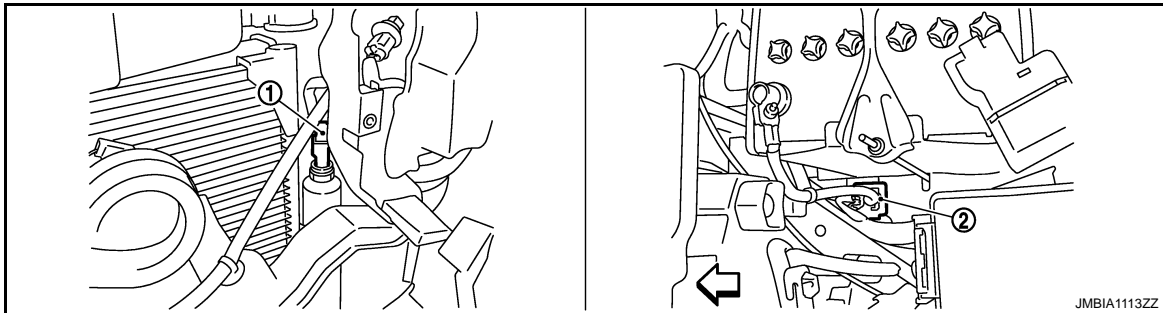

- 1. Refrigerant pressure sensor
- 2. Battery current sensor

↶ : Vehicle front

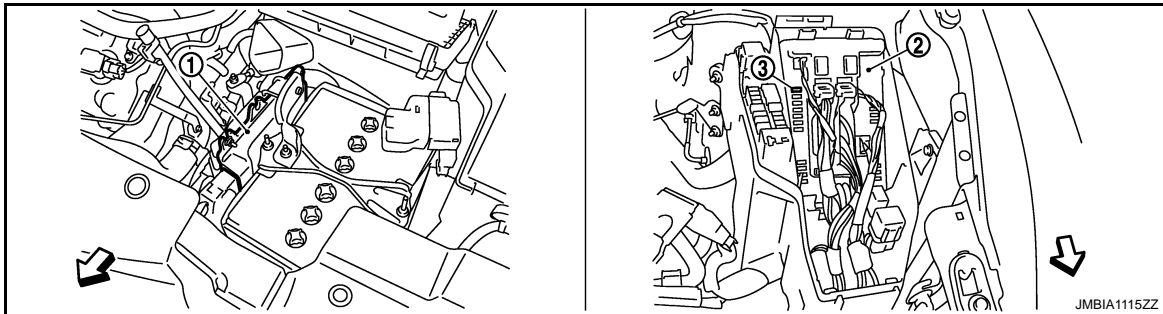

- 1. ECM
- 2. IPDM E/R
- 3. Fuel pump fuse

↶ : Vehicle front

COOLING FAN CONTROL

< FUNCTION DIAGNOSIS >

[VQ35DE]

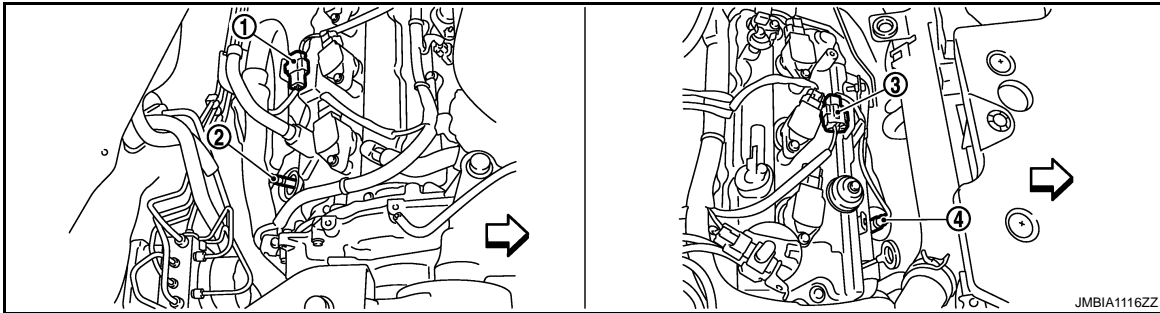
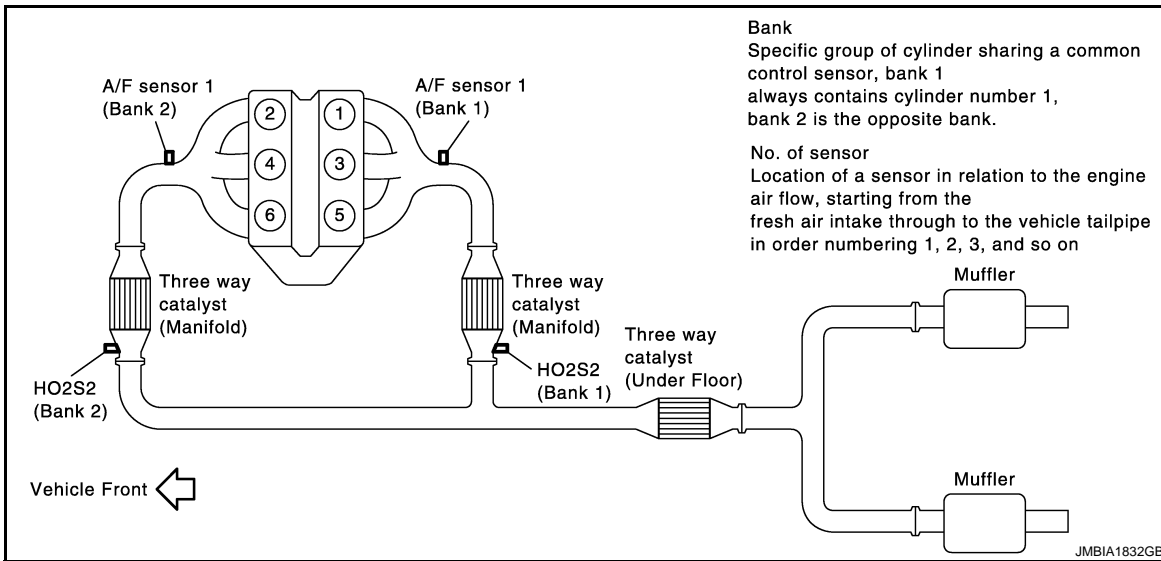

1. A/F sensor 1 (bank 1) harness connector
 2. A/F sensor 1 (bank 1)
 3. A/F sensor 1 (bank 2) harness connector
 4. A/F sensor 1 (bank 2)
- ← : Vehicle front

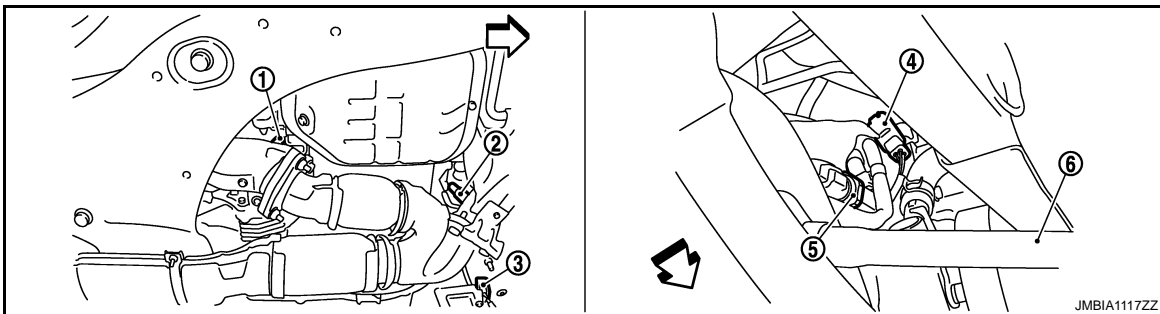

1. HO2S2 (bank 1)
 2. HO2S2 (bank 2)
 3. HO2S2 (bank 2) harness connector
 4. HO2S2 (bank 1) harness connector
 5. Power steering pressure sensor
 6. Drive shaft (RH)
- ← : Vehicle front

A
EC
C
D
E
F
G
H
I
J
K
L
M
N
O
P

COOLING FAN CONTROL

< FUNCTION DIAGNOSIS >

[VQ35DE]

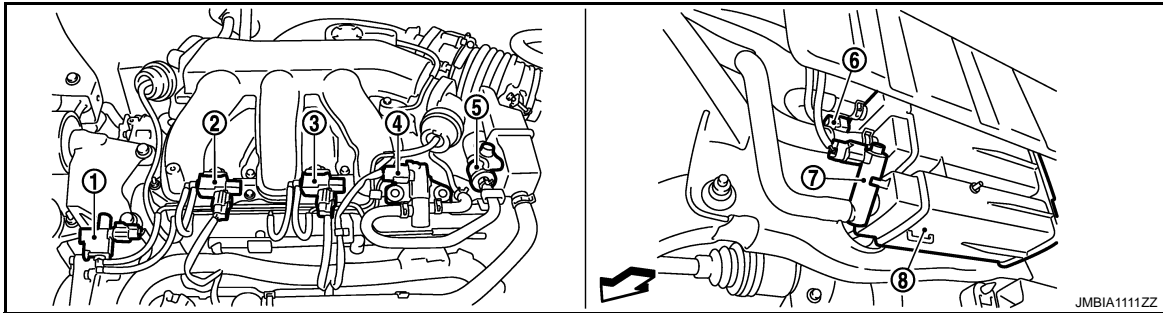

- 1. Electronic controlled engine mount control solenoid valve
- 2. VIAS control solenoid valve 1
- 3. VIAS control solenoid valve 2
- 4. EVAP canister purge volume control solenoid valve
- 5. EVAP service port
- 6. EVAP control system pressure sensor
- 7. EVAP canister vent control valve
- 8. EVAP canister

↶ : Vehicle front

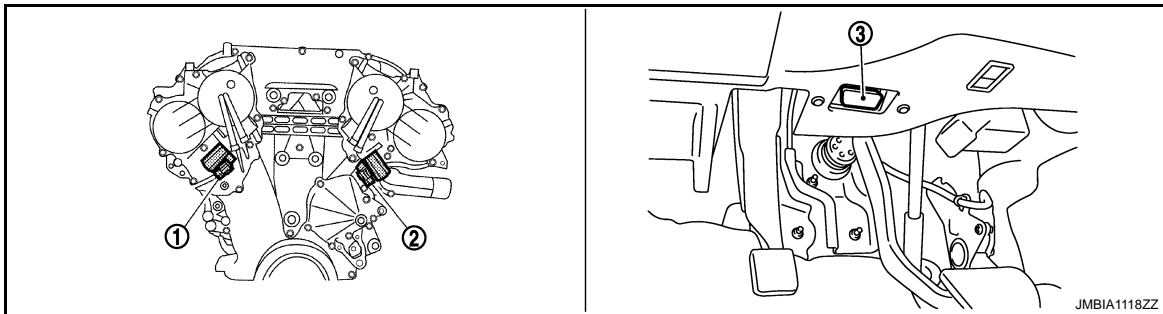

- 1. Intake valve timing control solenoid valve (bank 1)
- 2. Intake valve timing control solenoid valve (bank 2)
- 3. Data link connector valve

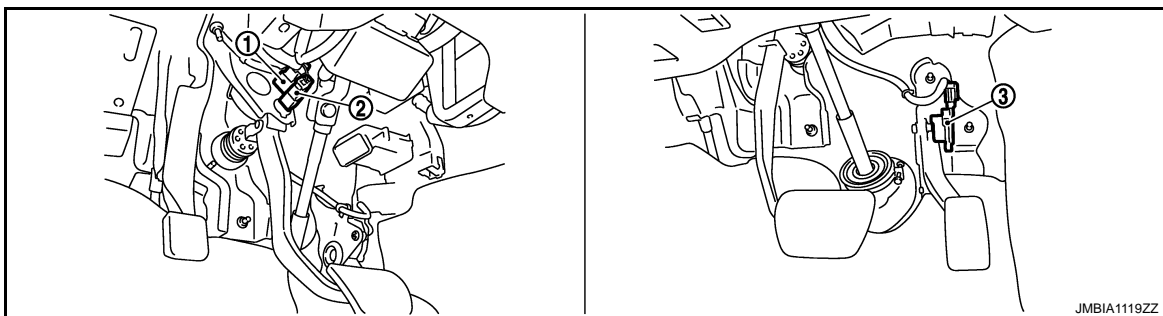

- 1. Stop lamp switch
- 2. ASCD brake switch
- 3. Accelerator pedal position sensor

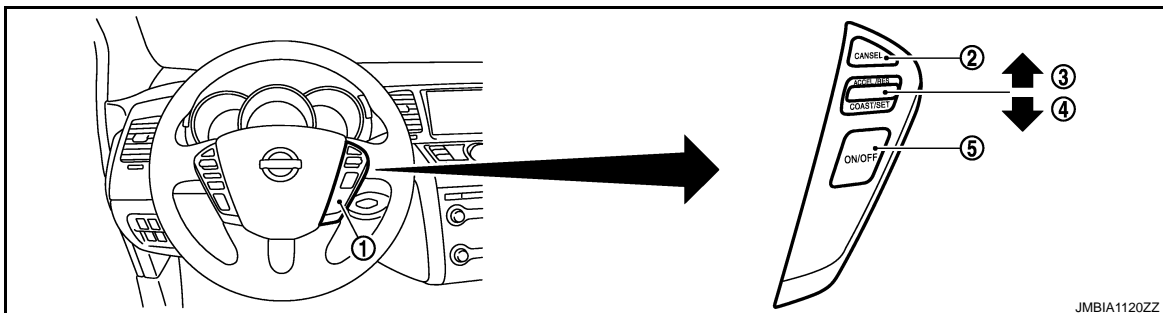

COOLING FAN CONTROL

[VQ35DE]

< FUNCTION DIAGNOSIS >

- | | | |
|-------------------------|------------------|-----------------------------|
| 1. ASCD steering switch | 2. CANCEL switch | 3. RESUME/ACCELERATE switch |
| 4. SET/COAST switch | 5. MAIN switch | |

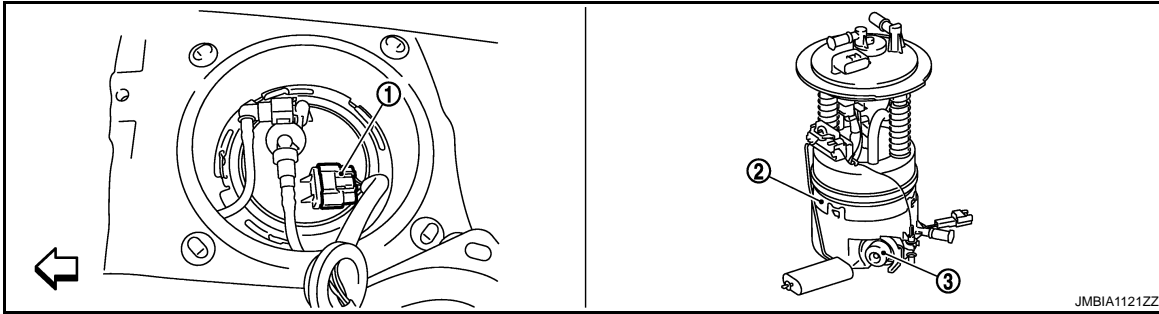

1. Fuel level sensor unit and fuel pump harness connector 2. Fuel level sensor unit and fuel pump 3. Fuel pressure regulator

← : Vehicle front

Component Description

INFOID:000000003387909

Component	Reference
Camshaft position sensor (PHASE)	EC-264, "Description"
Cooling fan motor	EC-434, "Description"
Crankshaft position sensor (POS)	EC-260, "Description"
Engine coolant temperature sensor	EC-170, "Description"
Refrigerant pressure sensor	EC-463, "Description"

ELECTRONIC CONTROLLED ENGINE MOUNT

< FUNCTION DIAGNOSIS >

[VQ35DE]

ELECTRONIC CONTROLLED ENGINE MOUNT

System Diagram

INFOID:000000003387910

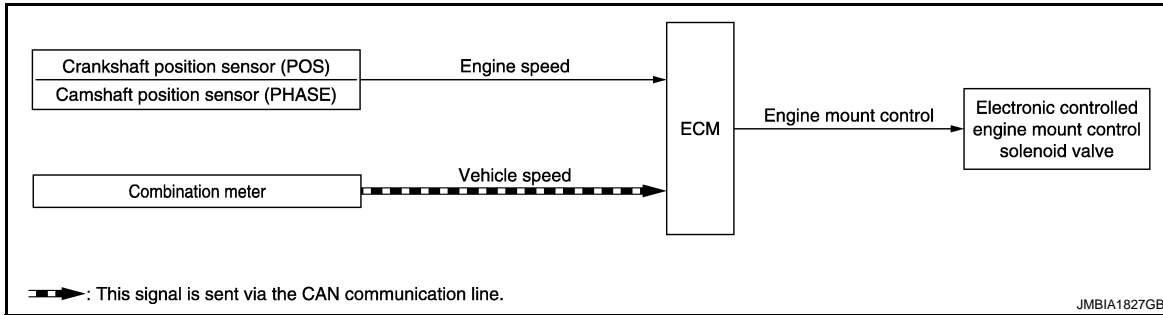

System Description

INFOID:000000003387911

INPUT/OUTPUT SIGNAL CHART

Sensor	Input signal to ECM	ECM function	Actuator
Crankshaft position sensor (POS) Camshaft position sensor (PHASE)	Engine speed	Engine mount control	Electronic controlled engine mount control solenoid valve
Combination meter	Vehicle speed*		

*: This signal is sent to the ECM via the CAN communication line.

SYSTEM DESCRIPTION

The ECM controls the engine mount operation corresponding to the engine speed. The control system has a 2-step control [Soft/Hard]

Vehicle condition	Engine mount control
Engine speed: Below 950 rpm	Soft
Engine speed: Above 950 rpm	Hard

ELECTRONIC CONTROLLED ENGINE MOUNT LINE DRAWING

ELECTRONIC CONTROLLED ENGINE MOUNT

< FUNCTION DIAGNOSIS >

[VQ35DE]

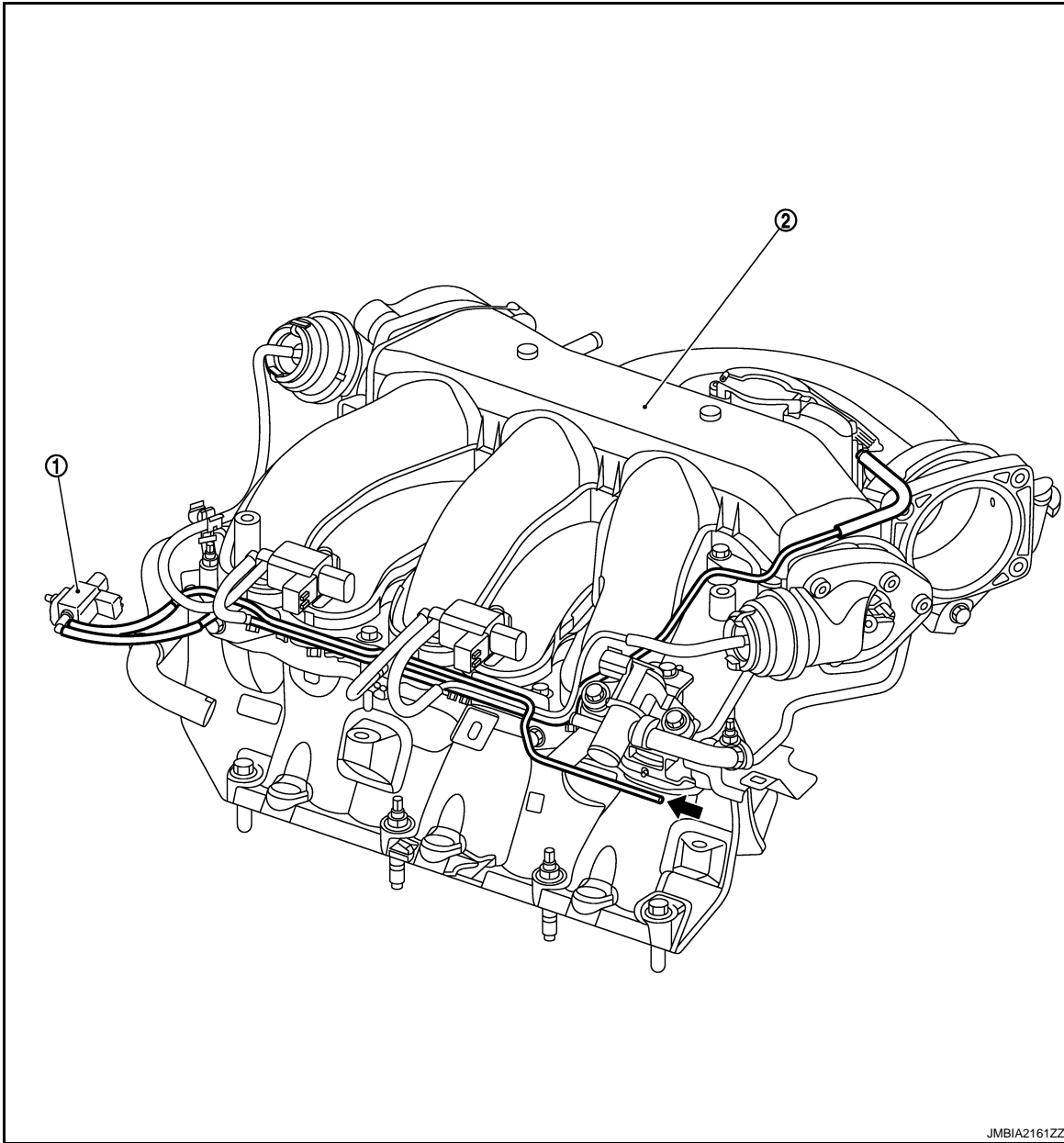

- 1. Electronic controlled engine mount control solenoid valve
- 2. Intake manifold collector

← : From next figure

A
EC
C
D
E
F
G
H
I
J
K
L
M
N
O
P

ELECTRONIC CONTROLLED ENGINE MOUNT

< FUNCTION DIAGNOSIS >

[VQ35DE]

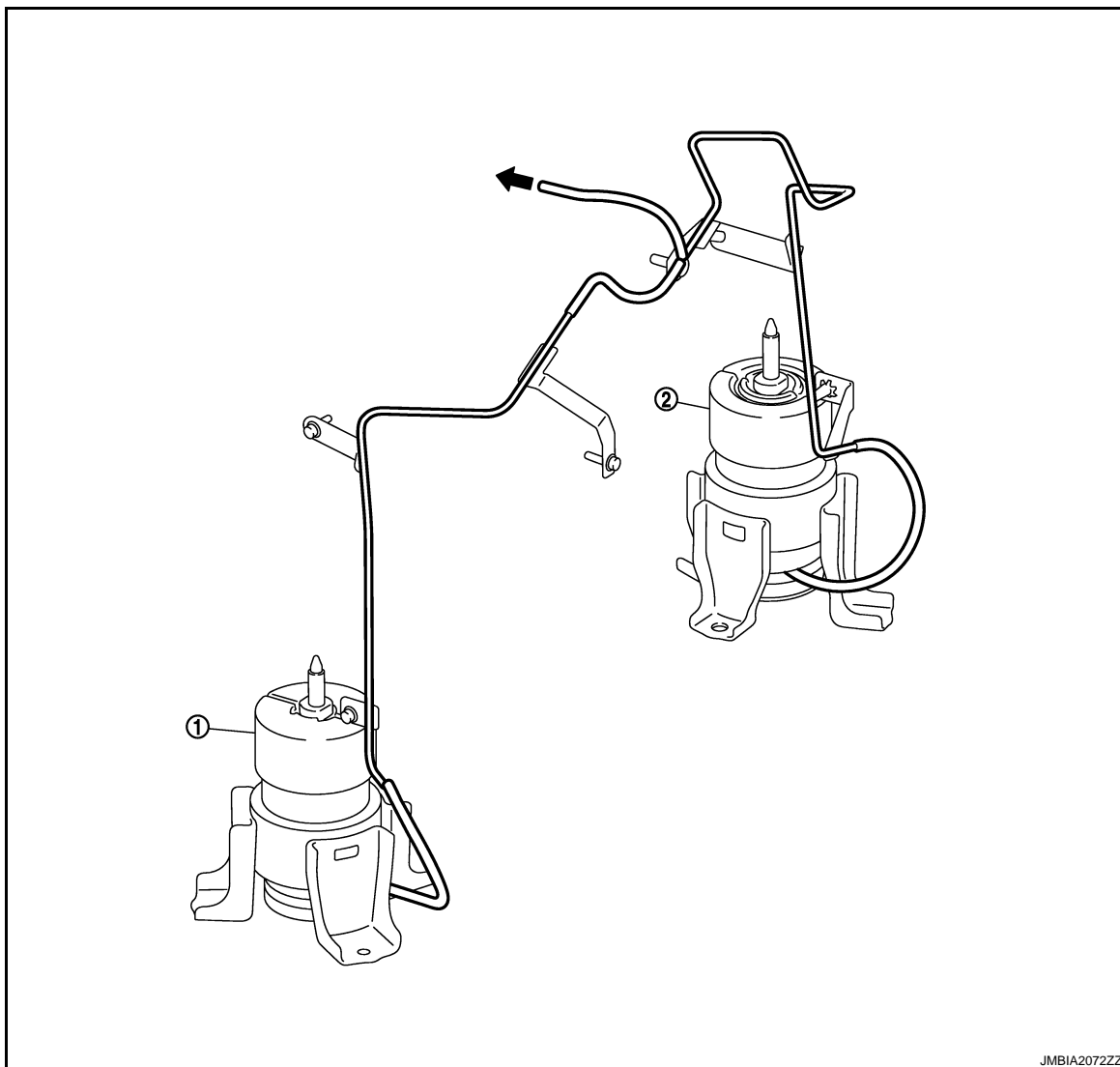

JMBIA2072ZZ

1. Front electronic controlled engine mount 2. Rear electronic controlled engine mount

← : To previous figure

NOTE:

Do not use soapy water or any type of solvent while installing vacuum hose.

ELECTRONIC CONTROLLED ENGINE MOUNT

< FUNCTION DIAGNOSIS >

[VQ35DE]

Component Parts Location

INFOID:000000003573789

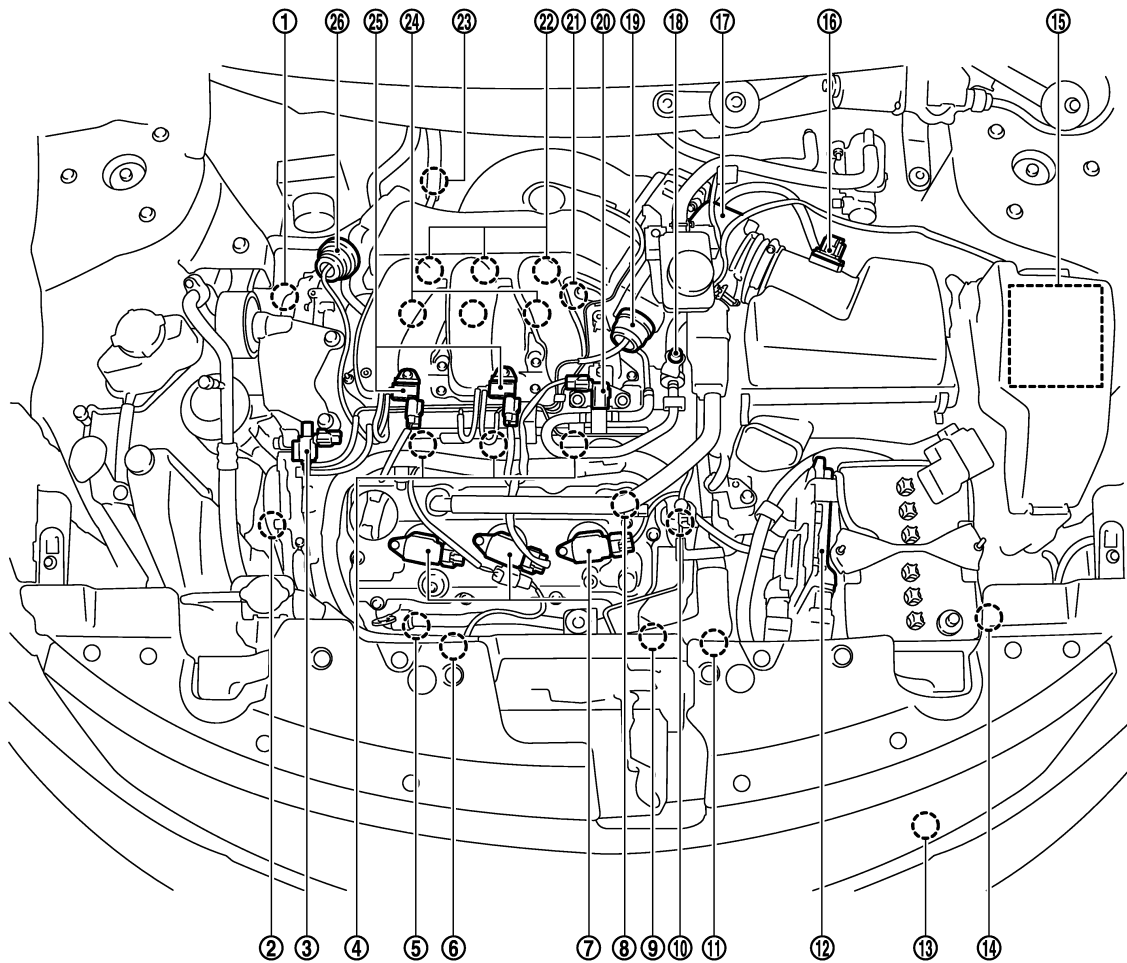

JMBIA1108ZZ

- | | | |
|---|--|--|
| 1. Intake valve timing control solenoid valve (bank 1) | 2. Intake valve timing control solenoid valve (bank 2) | 3. Electronic controlled engine mount control solenoid valve |
| 4. Fuel injector (bank 2) | 5. A/F sensor 1 (bank 2) | 6. Cooling fan motor-2 |
| 7. Ignition coil (with power transistor) and spark plug (bank 2) | 8. Camshaft position sensor (PHASE) (bank 2) | 9. Crankshaft position sensor (POS) |
| 10. Engine coolant temperature sensor | 11. Cooling fan motor-1 | 12. ECM |
| 13. Refrigerant pressure sensor | 14. Battery current sensor | 15. IPDM E/R |
| 16. Mass air flow sensor (with intake air temperature sensor) | 17. Electric throttle control actuator | 18. EVAP service port |
| 19. Power valve actuator 2 | 20. EVAP canister purge volume control solenoid valve | 21. Camshaft position sensor (PHASE) (bank 1) |
| 22. Ignition coil (with power transistor) and spark plug (bank 1) | 23. A/F sensor 1 (bank 1) | 24. Fuel injector (bank 1) |
| 25. VIAS control solenoid valve 1 and 2 | 26. Power valve actuator 1 | |

ELECTRONIC CONTROLLED ENGINE MOUNT

< FUNCTION DIAGNOSIS >

[VQ35DE]

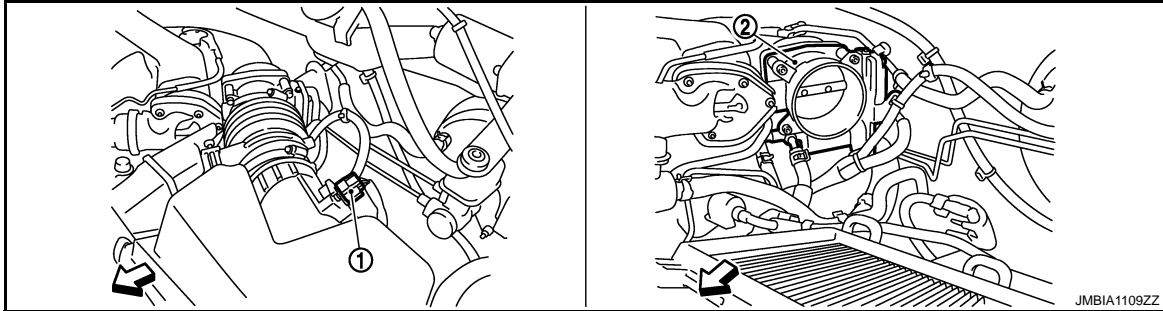

- 1. Mas air flow sensor (with intake air temperature sensor)
- 2. Electric throttle control actuator

← : Vehicle front

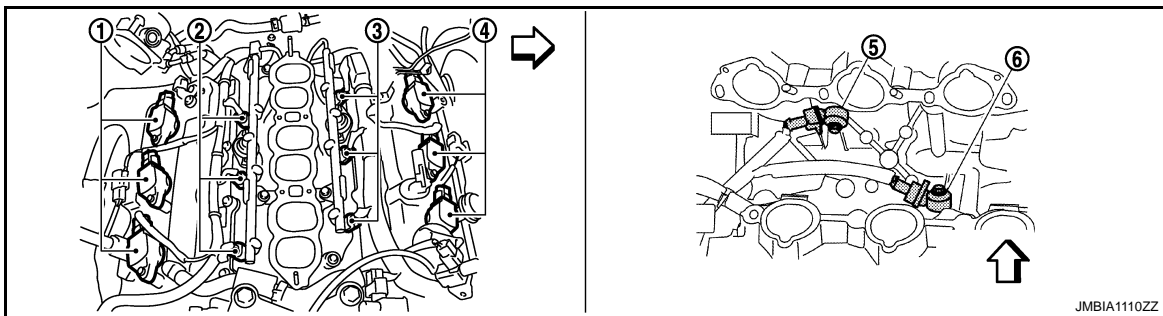

- 1. Ignition coil (with power transistor and spark plug (bank 1))
- 2. Fuel injector (bank 1)
- 3. Fuel injector (bank 2)
- 4. Ignition coil (with power transistor and spark plug (bank 2))
- 5. Knock sensor (bank 2)
- 6. Knock sensor (bank 1)

← : Vehicle front

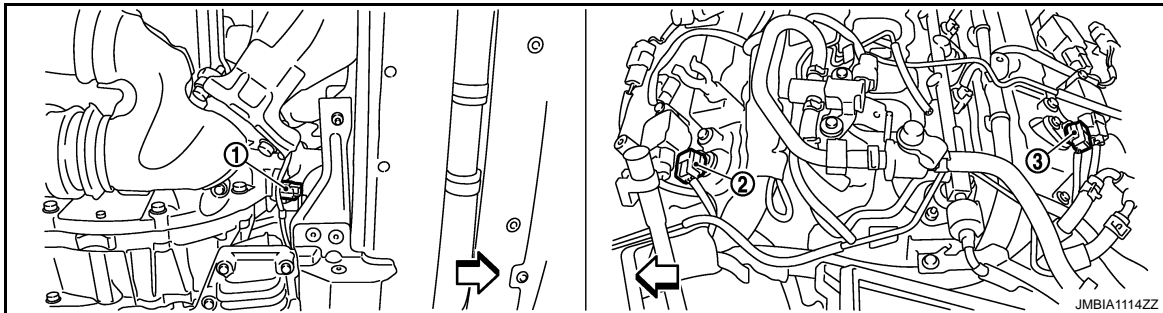

- 1. Crankshaft position sensor (POS)
- 2. Camshaft position sensor (PHASE) (bank 1)
- 3. Camshaft position sensor (PHASE) (bank 2)

← : Vehicle front

ELECTRONIC CONTROLLED ENGINE MOUNT

< FUNCTION DIAGNOSIS >

[VQ35DE]

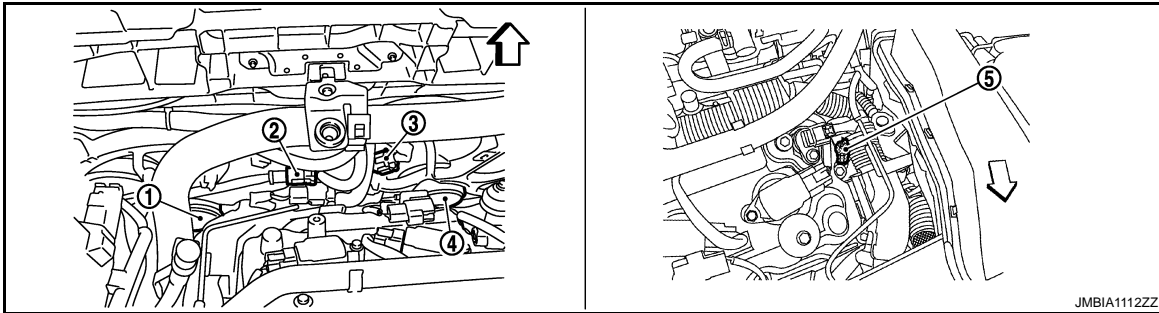

- 1. Cooling fan motor-1
- 2. Cooling fan motor-1 harness connector
- 3. Cooling fan motor-1 harness connector
- 4. Cooling fan motor-2
- 5. Engine coolant temperature sensor

↶ : Vehicle front

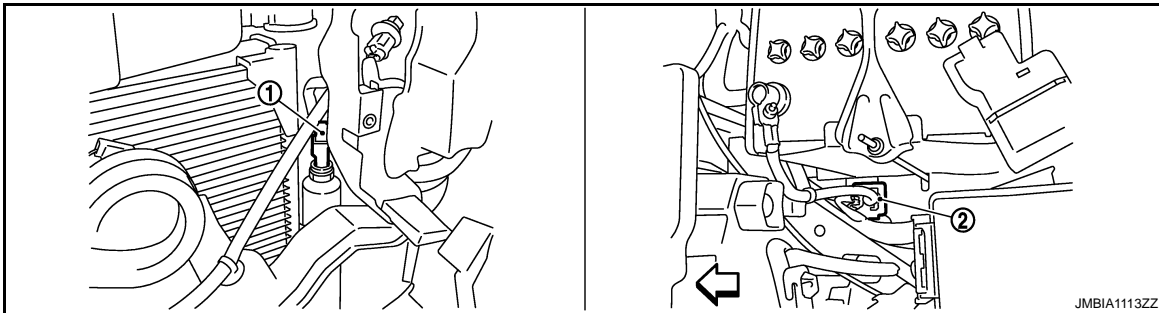

- 1. Refrigerant pressure sensor
- 2. Battery current sensor

↶ : Vehicle front

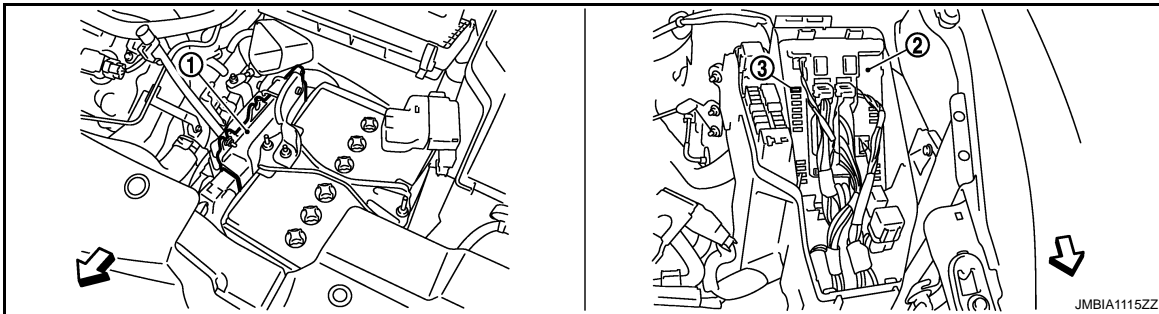

- 1. ECM
- 2. IPDM E/R
- 3. Fuel pump fuse

↶ : Vehicle front

A
EC
C
D
E
F
G
H
I
J
K
L
M
N
O
P

ELECTRONIC CONTROLLED ENGINE MOUNT

< FUNCTION DIAGNOSIS >

[VQ35DE]

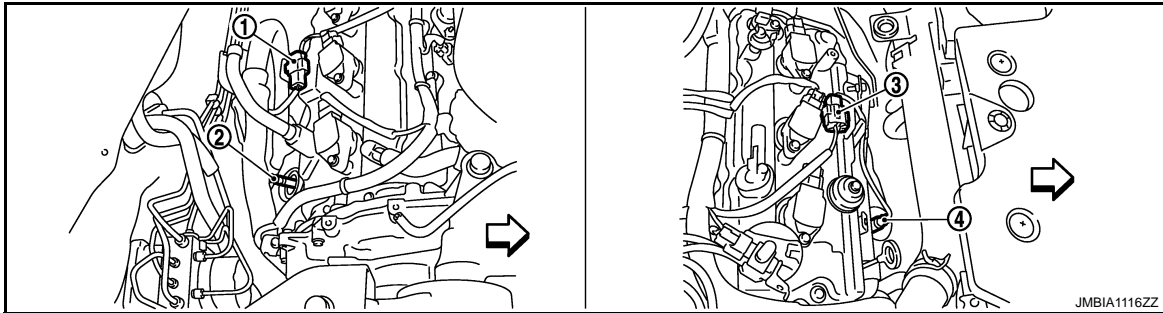
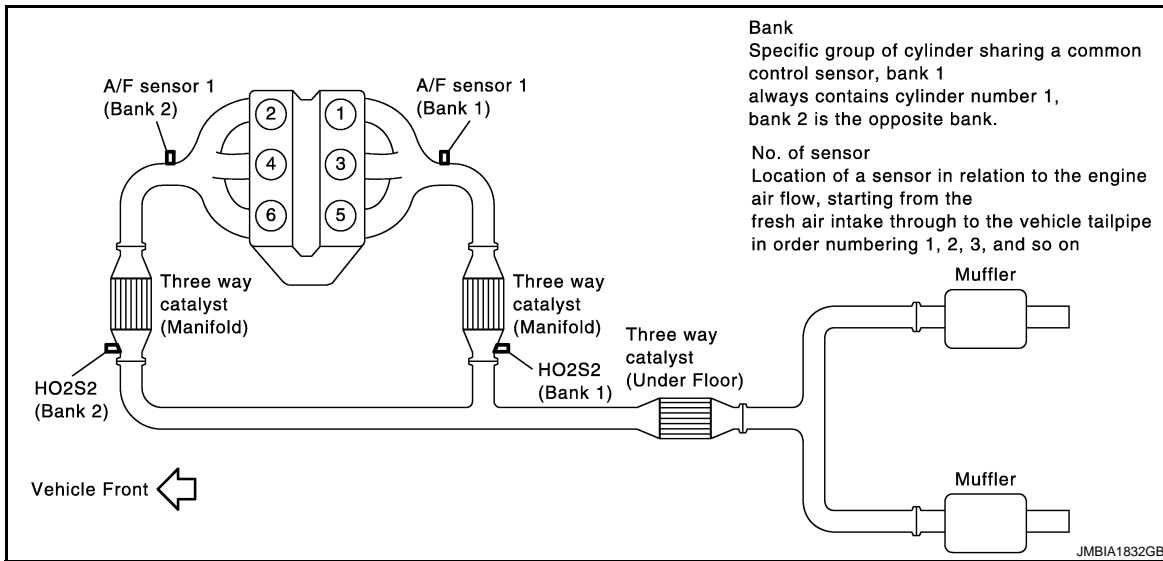

- 1. A/F sensor 1 (bank 1) harness connector
- 2. A/F sensor 1 (bank 1)
- 3. A/F sensor 1 (bank 2) harness connector

- 4. A/F sensor 1 (bank 2)

← : Vehicle front

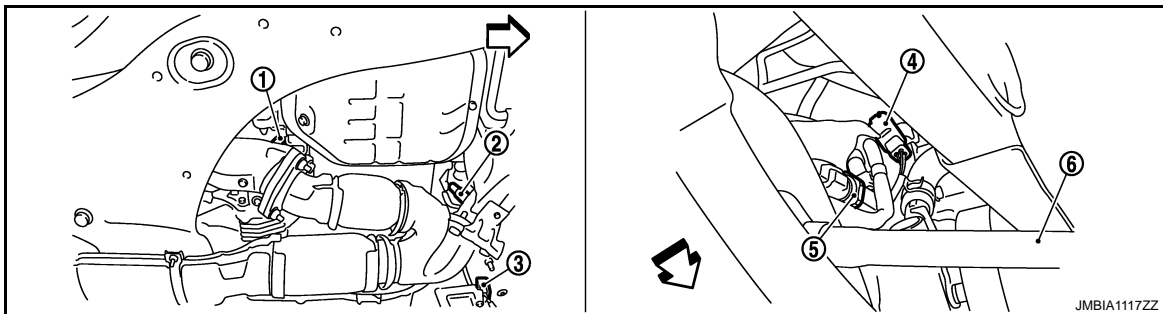

- 1. HO2S2 (bank 1)
- 2. HO2S2 (bank 2)
- 3. HO2S2 (bank 2) harness connector
- 4. HO2S2 (bank 1) harness connector
- 5. Power steering pressure sensor
- 6. Drive shaft (RH)

← : Vehicle front

ELECTRONIC CONTROLLED ENGINE MOUNT

< FUNCTION DIAGNOSIS >

[VQ35DE]

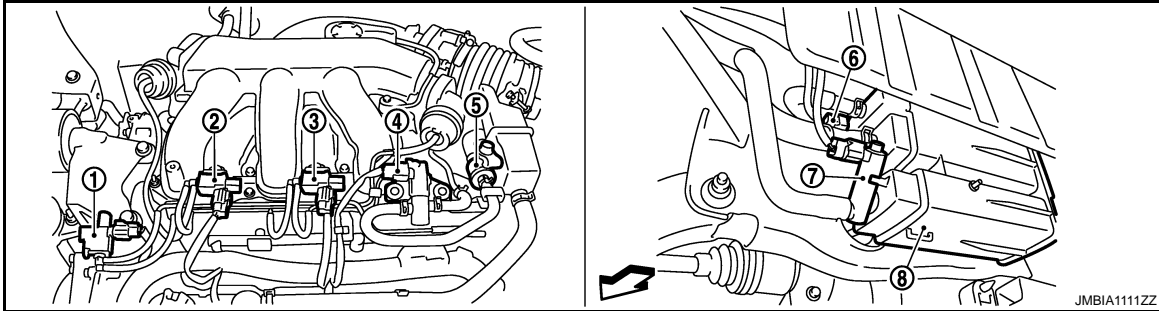

- 1. Electronic controlled engine mount control solenoid valve
- 2. VIAS control solenoid valve 1
- 3. VIAS control solenoid valve 2
- 4. EVAP canister purge volume control solenoid valve
- 5. EVAP service port
- 6. EVAP control system pressure sensor
- 7. EVAP canister vent control valve
- 8. EVAP canister

← : Vehicle front

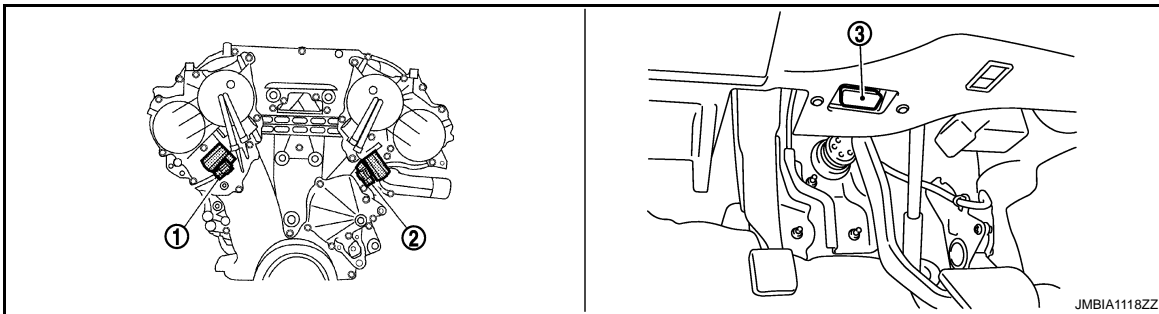

- 1. Intake valve timing control solenoid valve (bank 1)
- 2. Intake valve timing control solenoid valve (bank 2)
- 3. Data link connector

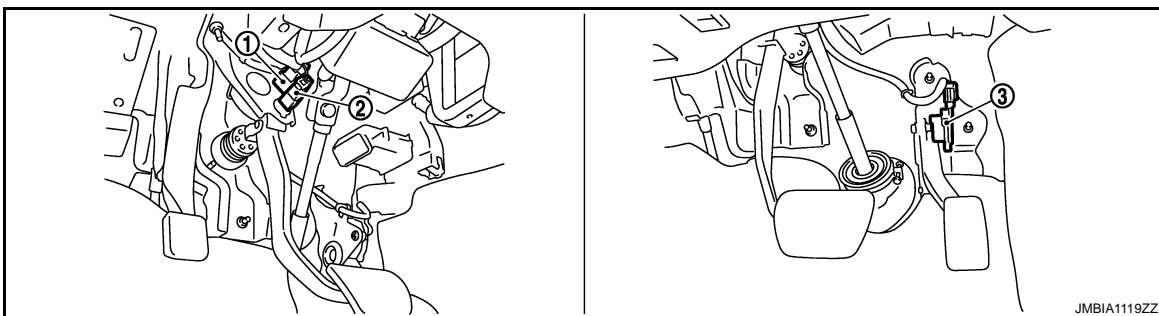

- 1. Stop lamp switch
- 2. ASCD brake switch
- 3. Accelerator pedal position sensor

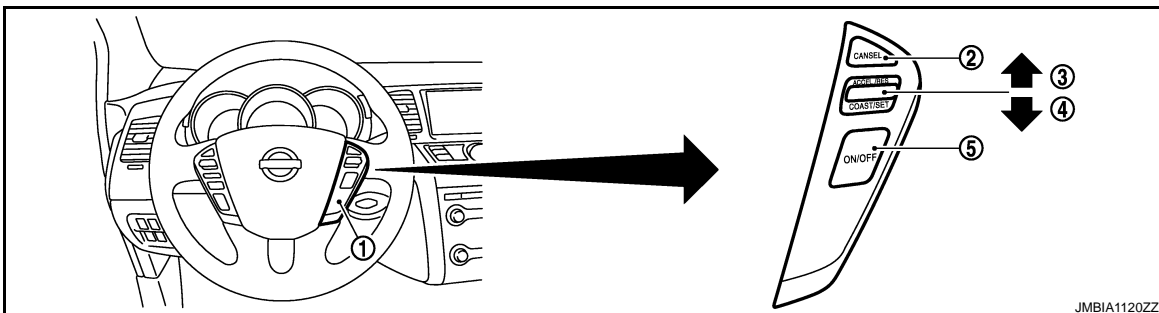

A
EC
C
D
E
F
G
H
I
J
K
L
M
N
O
P

ELECTRONIC CONTROLLED ENGINE MOUNT

[VQ35DE]

< FUNCTION DIAGNOSIS >

- | | | |
|-------------------------|------------------|-----------------------------|
| 1. ASCD steering switch | 2. CANCEL switch | 3. RESUME/ACCELERATE switch |
| 4. SET/COAST switch | 5. MAIN switch | |

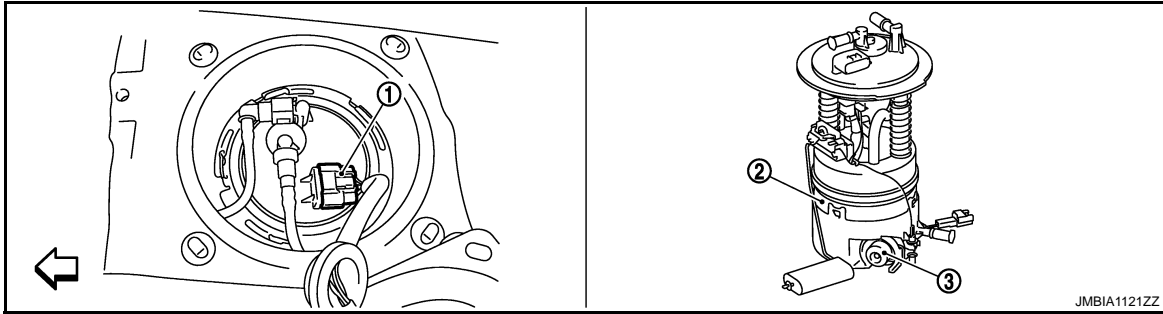

1. Fuel level sensor unit and fuel pump harness connector 2. Fuel level sensor unit and fuel pump 3. Fuel pressure regulator

← : Vehicle front

Component Description

INFOID:000000003387913

Component	Reference
Camshaft position sensor (PHASE)	EC-264, "Description"
Crankshaft position sensor (POS)	EC-260, "Description"
Electronic controlled engine mount control solenoid valve	EC-441, "Description"

EVAPORATIVE EMISSION SYSTEM

< FUNCTION DIAGNOSIS >

[VQ35DE]

EVAPORATIVE EMISSION SYSTEM

System Diagram

INFOID:000000003387914

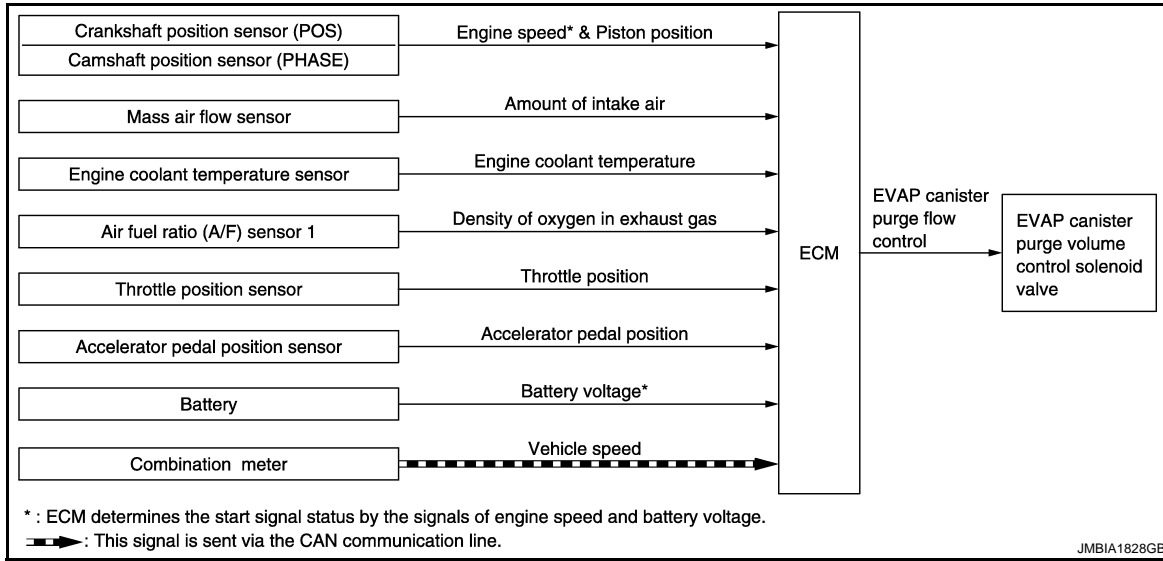

System Description

INFOID:000000003387915

INPUT/OUTPUT SIGNAL CHART

Sensor	Input signal to ECM	ECM function	Actuator
Crankshaft position sensor (POS)	Engine speed* ¹ Piston position	EVAP canister purge flow control	EVAP canister purge vol- ume control solenoid valve
Camshaft position sensor (PHASE)			
Mass air flow sensor	Amount of intake air		
Engine coolant temperature sensor	Engine coolant temperature		
Air fuel ratio (A/F) sensor 1	Density of oxygen in exhaust gas (Mixture ratio feedback signal)		
Throttle position sensor	Throttle position		
Accelerator pedal position sensor	Accelerator pedal position		
Battery	Battery voltage* ¹		
Combination meter	Vehicle speed* ²		

*1: ECM determines the start signal status by the signals of engine speed and battery voltage.

*2: This signal is sent to the ECM via the CAN communication line.

EVAPORATIVE EMISSION SYSTEM

[VQ35DE]

< FUNCTION DIAGNOSIS >

SYSTEM DESCRIPTION

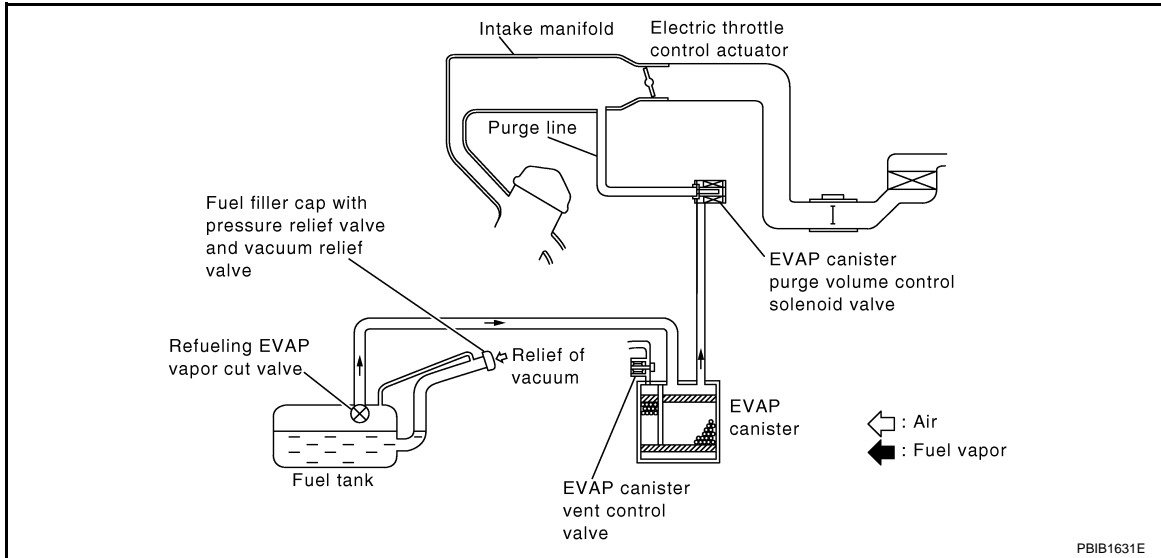

The evaporative emission system is used to reduce hydrocarbons emitted into the atmosphere from the fuel system. This reduction of hydrocarbons is accomplished by activated charcoals in the EVAP canister. The fuel vapor in the sealed fuel tank is led into the EVAP canister which contains activated carbon and the vapor is stored there when the engine is not operating or when refueling to the fuel tank. The vapor in the EVAP canister is purged by the air through the purge line to the intake manifold when the engine is operating. EVAP canister purge volume control solenoid valve is controlled by ECM. When the engine operates, the flow rate of vapor controlled by EVAP canister purge volume control solenoid valve is proportionally regulated as the air flow increases. EVAP canister purge volume control solenoid valve also shuts off the vapor purge line during decelerating and idling.

EVAPORATIVE EMISSION LINE DRAWING

EVAPORATIVE EMISSION SYSTEM

< FUNCTION DIAGNOSIS >

[VQ35DE]

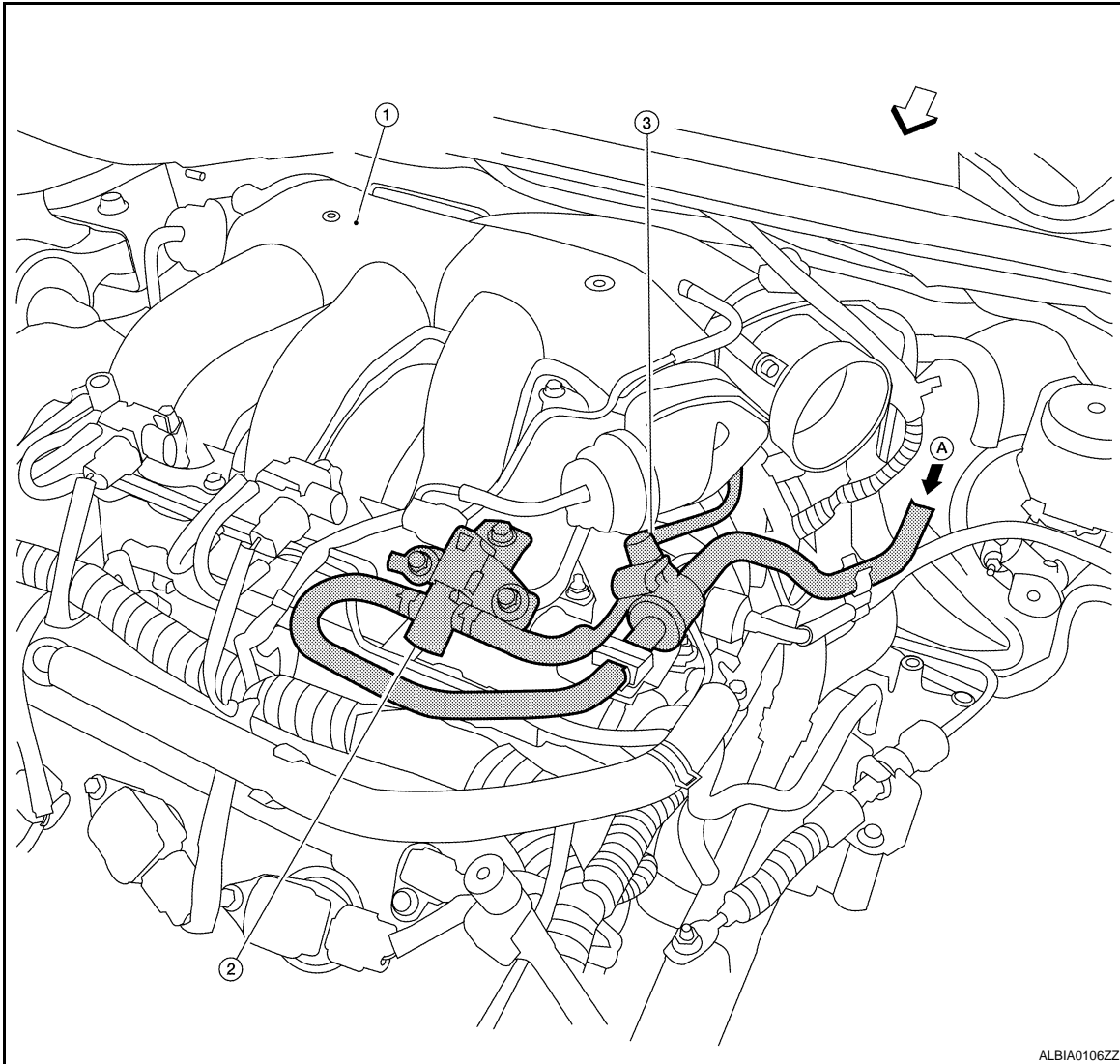

1. Intake manifold collector 2. EVAP canister purge volume control 3. EVAP service port solenoid valve

A. From EVAP canister

↙ : Vehicle front

A

EC

C

D

E

F

G

H

I

J

K

L

M

N

O

P

EVAPORATIVE EMISSION SYSTEM

< FUNCTION DIAGNOSIS >

[VQ35DE]

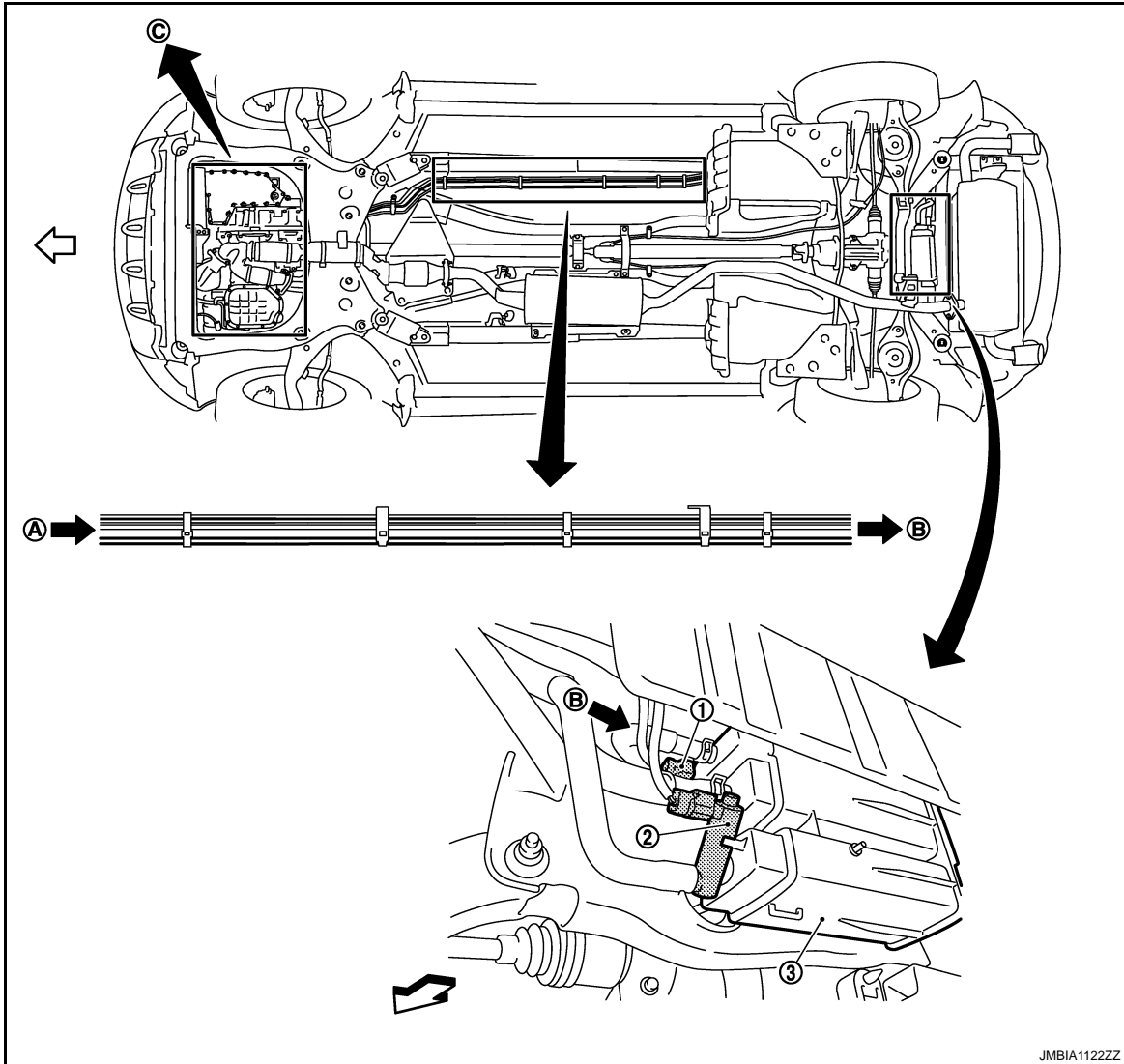

JMBIA1122ZZ

- 1. EVAP control system pressure sensor
 - 2. EVAP canister vent control valve
 - 3. EVAP canister
 - A. To previous figure
 - B. To/From B in this figure
 - C. Refer to previous figure
- ↙ : Vehicle front

NOTE:

Do not use soapy water or any type of solvent while installing vacuum hose or purge hoses.

EVAPORATIVE EMISSION SYSTEM

< FUNCTION DIAGNOSIS >

[VQ35DE]

Component Parts Location

INFOID:000000003573791

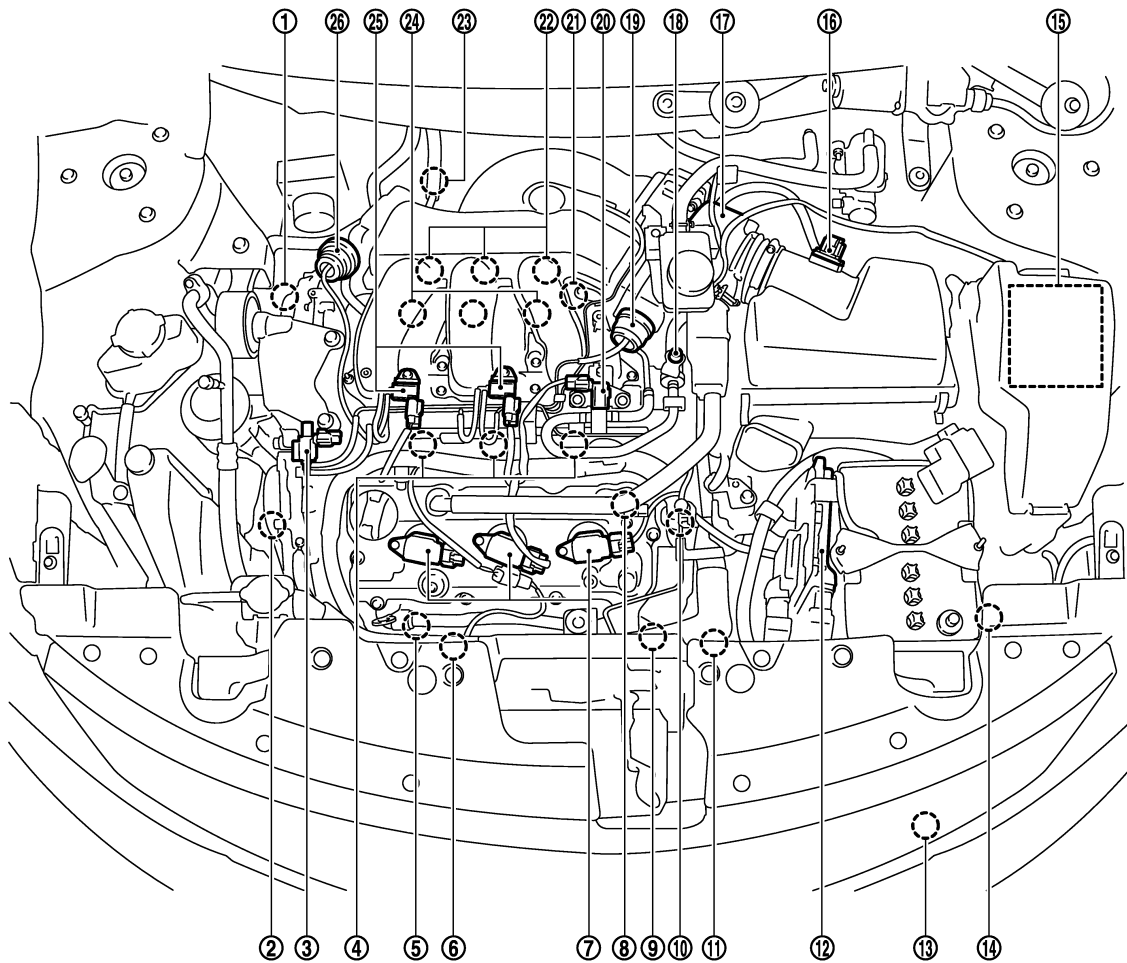

JMBIA1108ZZ

- | | | |
|---|--|--|
| 1. Intake valve timing control solenoid valve (bank 1) | 2. Intake valve timing control solenoid valve (bank 2) | 3. Electronic controlled engine mount control solenoid valve |
| 4. Fuel injector (bank 2) | 5. A/F sensor 1 (bank 2) | 6. Cooling fan motor-2 |
| 7. Ignition coil (with power transistor) and spark plug (bank 2) | 8. Camshaft position sensor (PHASE) (bank 2) | 9. Crankshaft position sensor (POS) |
| 10. Engine coolant temperature sensor | 11. Cooling fan motor-1 | 12. ECM |
| 13. Refrigerant pressure sensor | 14. Battery current sensor | 15. IPDM E/R |
| 16. Mass air flow sensor (with intake air temperature sensor) | 17. Electric throttle control actuator | 18. EVAP service port |
| 19. Power valve actuator 2 | 20. EVAP canister purge volume control solenoid valve | 21. Camshaft position sensor (PHASE) (bank 1) |
| 22. Ignition coil (with power transistor) and spark plug (bank 1) | 23. A/F sensor 1 (bank 1) | 24. Fuel injector (bank 1) |
| 25. VIAS control solenoid valve 1 and 2 | 26. Power valve actuator 1 | |

EVAPORATIVE EMISSION SYSTEM

< FUNCTION DIAGNOSIS >

[VQ35DE]

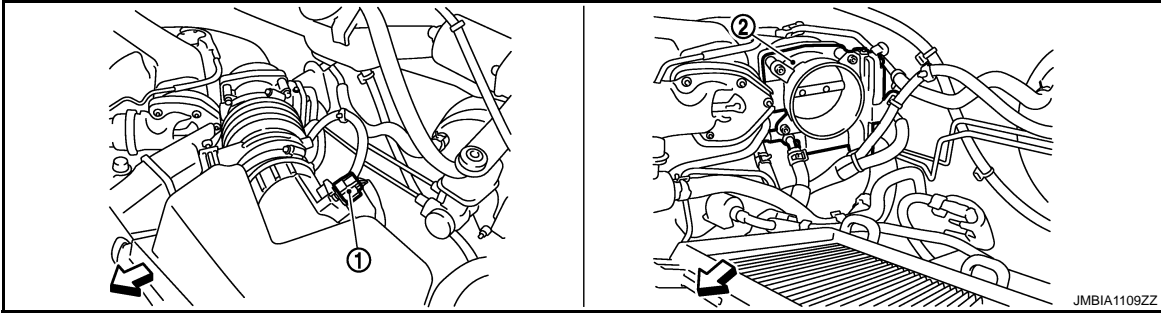

- 1. Maf air flow sensor (with intake air temperature sensor)
- 2. Electric throttle control actuator

← : Vehicle front

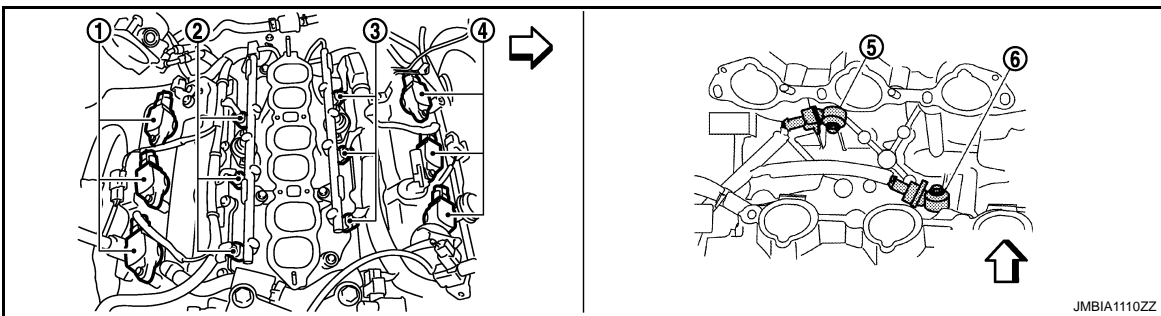

- 1. Ignition coil (with power transistor and spark plug (bank 1))
- 2. Fuel injector (bank 1)
- 3. Fuel injector (bank 2)
- 4. Ignition coil (with power transistor and spark plug (bank 2))
- 5. Knock sensor (bank 2)
- 6. Knock sensor (bank 1)

← : Vehicle front

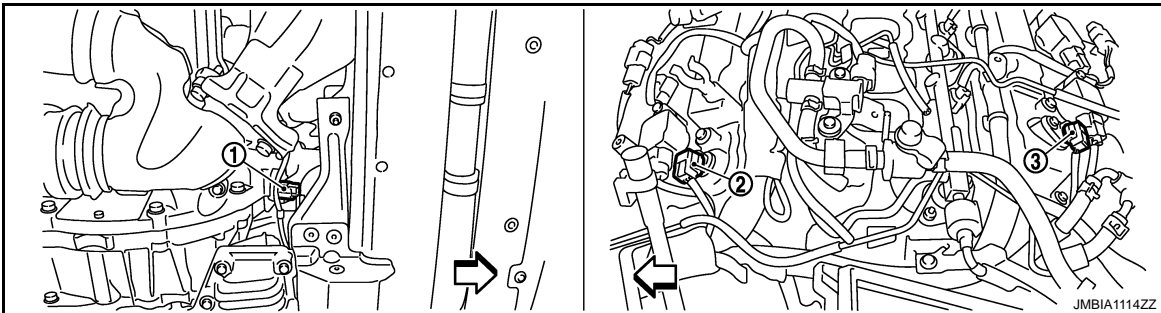

- 1. Crankshaft position sensor (POS)
- 2. Camshaft position sensor (PHASE) (bank 1)
- 3. Camshaft position sensor (PHASE) (bank 2)

← : Vehicle front

EVAPORATIVE EMISSION SYSTEM

< FUNCTION DIAGNOSIS >

[VQ35DE]

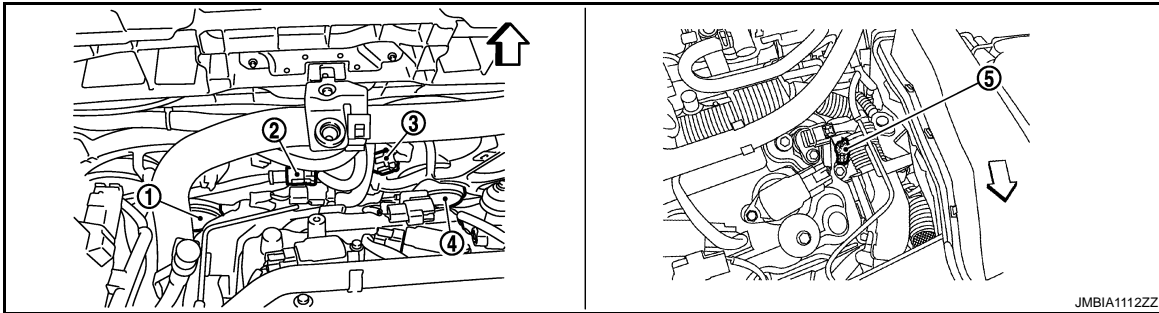

- 1. Cooling fan motor-1
- 2. Cooling fan motor-1 harness connector
- 3. Cooling fan motor-1 harness connector
- 4. Cooling fan motor-2
- 5. Engine coolant temperature sensor

↶ : Vehicle front

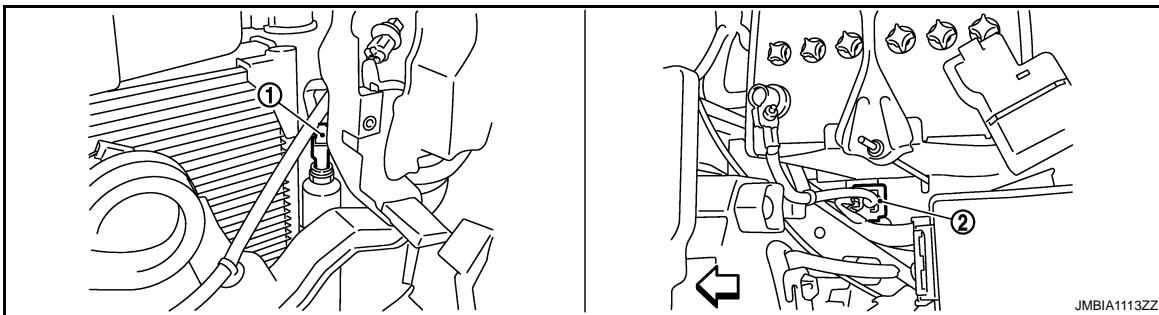

- 1. Refrigerant pressure sensor
- 2. Battery current sensor

↶ : Vehicle front

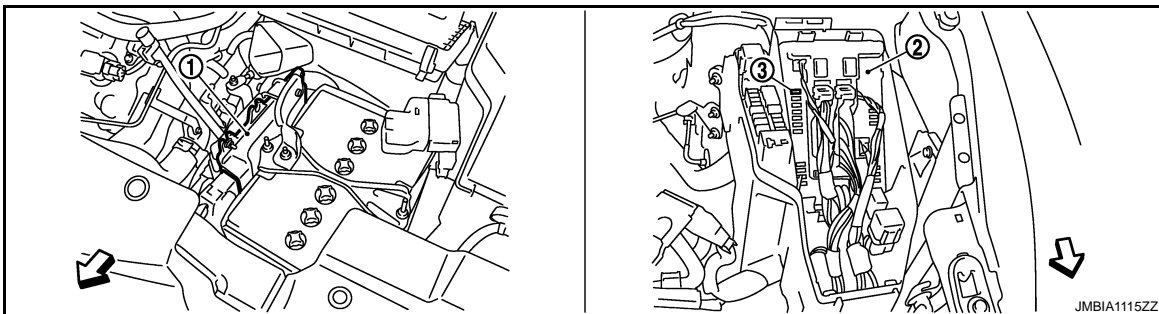

- 1. ECM
- 2. IPDM E/R
- 3. Fuel pump fuse

↶ : Vehicle front

A
EC
C
D
E
F
G
H
I
J
K
L
M
N
O
P

EVAPORATIVE EMISSION SYSTEM

< FUNCTION DIAGNOSIS >

[VQ35DE]

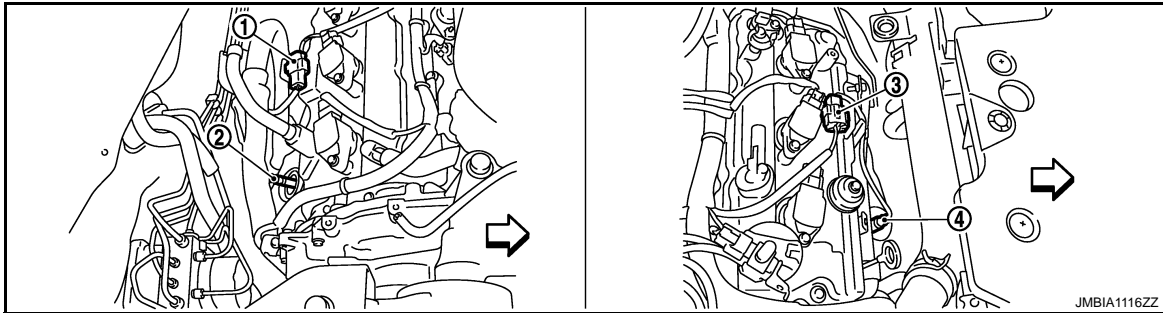
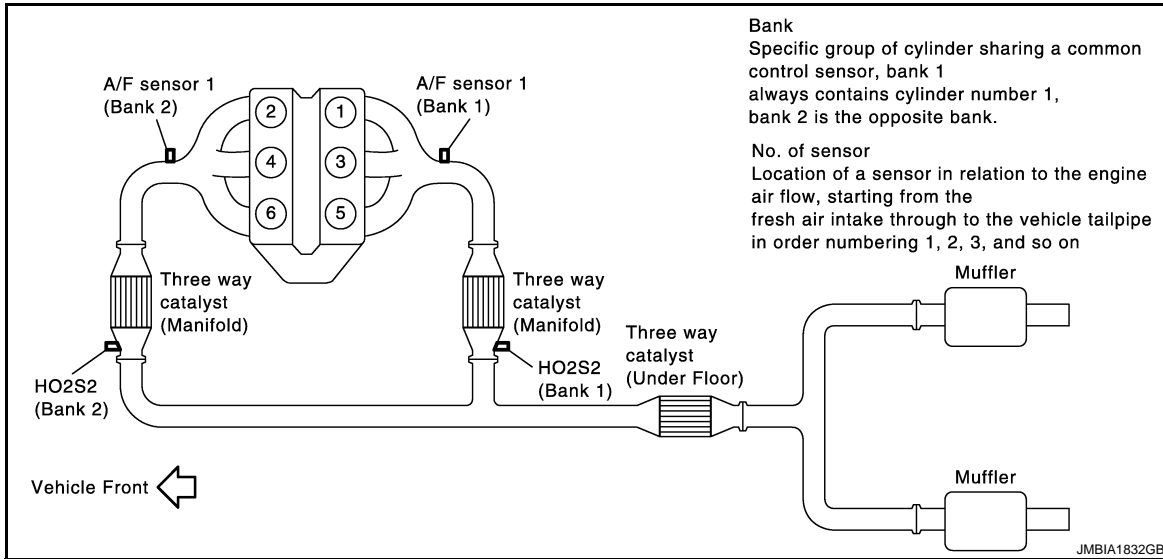

- 1. A/F sensor 1 (bank 1) harness connector
- 2. A/F sensor 1 (bank 1)
- 3. A/F sensor 1 (bank 2) harness connector

- 4. A/F sensor 1 (bank 2)

← : Vehicle front

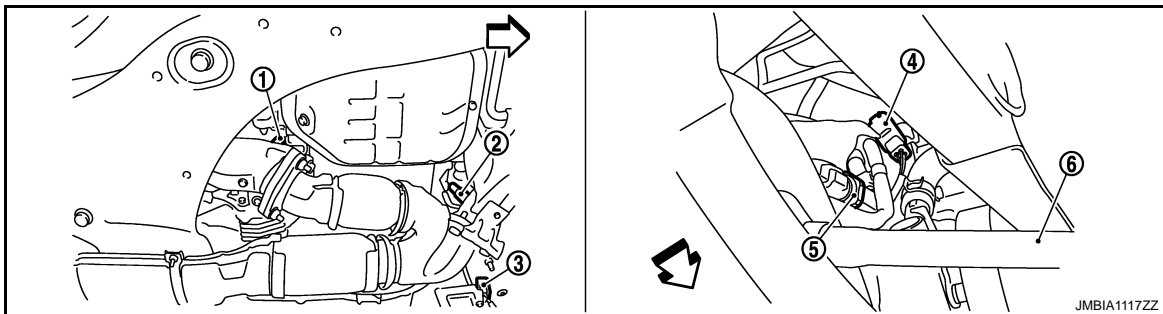

- 1. HO2S2 (bank 1)
- 2. HO2S2 (bank 2)
- 3. HO2S2 (bank 2) harness connector
- 4. HO2S2 (bank 1) harness connector
- 5. Power steering pressure sensor
- 6. Drive shaft (RH)

← : Vehicle front

EVAPORATIVE EMISSION SYSTEM

< FUNCTION DIAGNOSIS >

[VQ35DE]

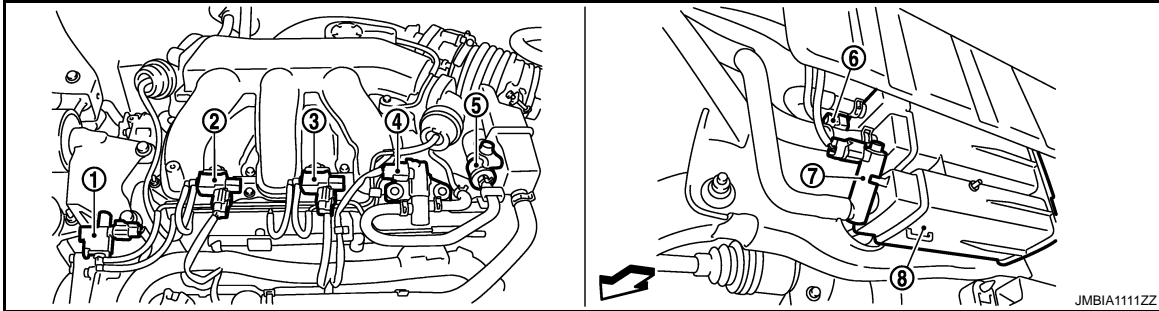

- | | | |
|--|----------------------------------|--|
| 1. Electronic controlled engine mount control solenoid valve | 2. VIAS control solenoid valve 1 | 3. VIAS control solenoid valve 2 |
| 4. EVAP canister purge volume control solenoid valve | 5. EVAP service port | 6. EVAP control system pressure sensor |
| 7. EVAP canister vent control valve | 8. EVAP canister | |

← : Vehicle front

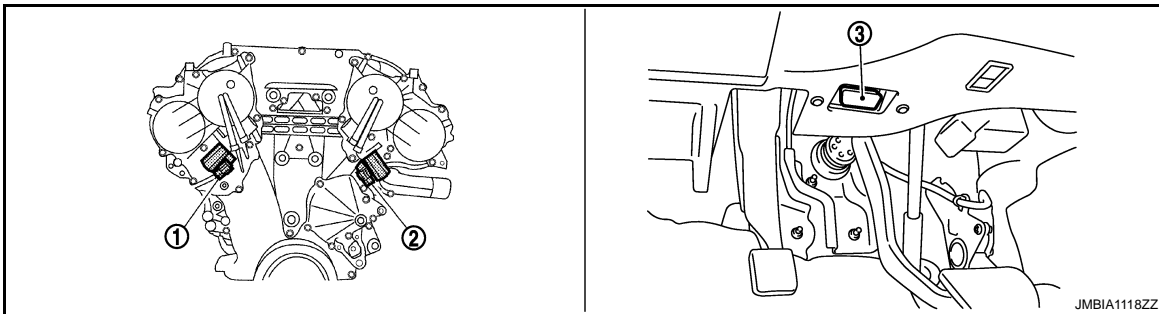

- | | | |
|--|--|------------------------|
| 1. Intake valve timing control solenoid valve (bank 1) | 2. Intake valve timing control solenoid valve (bank 2) | 3. Data link connector |
|--|--|------------------------|

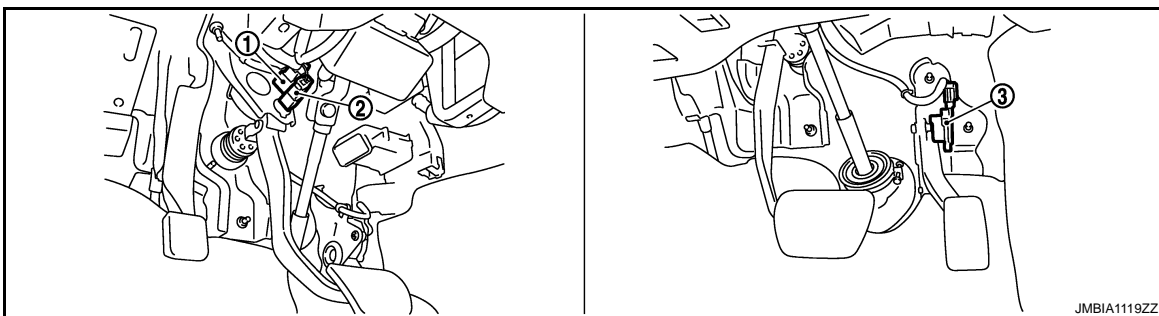

- | | | |
|---------------------|----------------------|--------------------------------------|
| 1. Stop lamp switch | 2. ASCD brake switch | 3. Accelerator pedal position sensor |
|---------------------|----------------------|--------------------------------------|

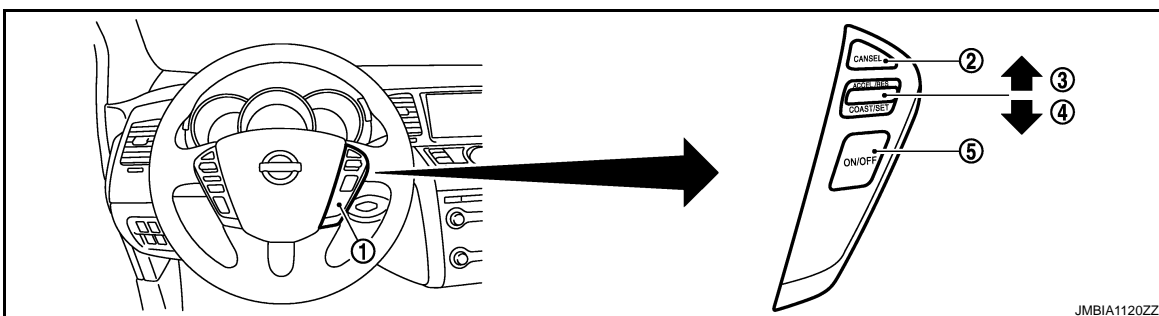

A
EC
C
D
E
F
G
H
I
J
K
L
M
N
O
P

EVAPORATIVE EMISSION SYSTEM

[VQ35DE]

< FUNCTION DIAGNOSIS >

- | | | |
|-------------------------|------------------|-----------------------------|
| 1. ASCD steering switch | 2. CANCEL switch | 3. RESUME/ACCELERATE switch |
| 4. SET/COAST switch | 5. MAIN switch | |

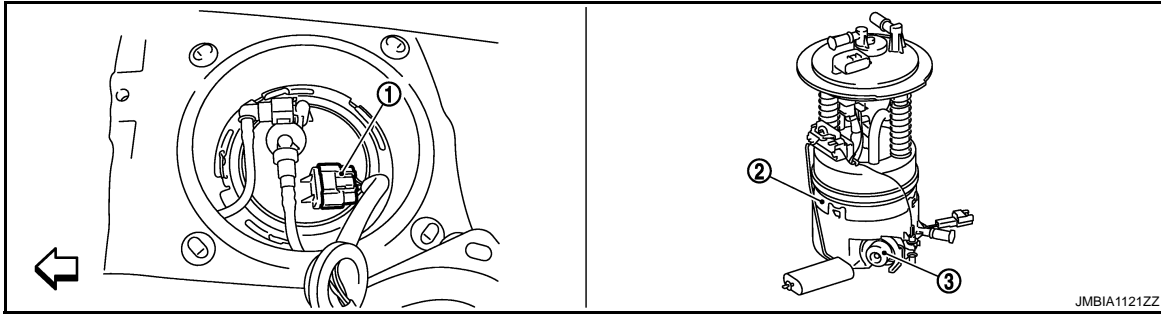

1. Fuel level sensor unit and fuel pump harness connector 2. Fuel level sensor unit and fuel pump 3. Fuel pressure regulator

← : Vehicle front

Component Description

INFOID:000000003387917

Component	Reference
A/F sensor 1	EC-186, "Description"
Accelerator pedal position sensor	EC-413, "Description"
Camshaft position sensor (PHASE)	EC-264, "Description"
Crankshaft position sensor (POS)	EC-260, "Description"
Engine coolant temperature sensor	EC-170, "Description"
EVAP canister purge volume control solenoid valve	EC-284, "Description"
EVAP control system pressure sensor	EC-300, "Description"
Fuel tank temperature sensor	EC-236, "Description"
Mass air flow sensor	EC-154, "Description"
Throttle position sensor	EC-175, "Description"

INTAKE VALVE TIMING CONTROL

< FUNCTION DIAGNOSIS >

[VQ35DE]

INTAKE VALVE TIMING CONTROL

System Diagram

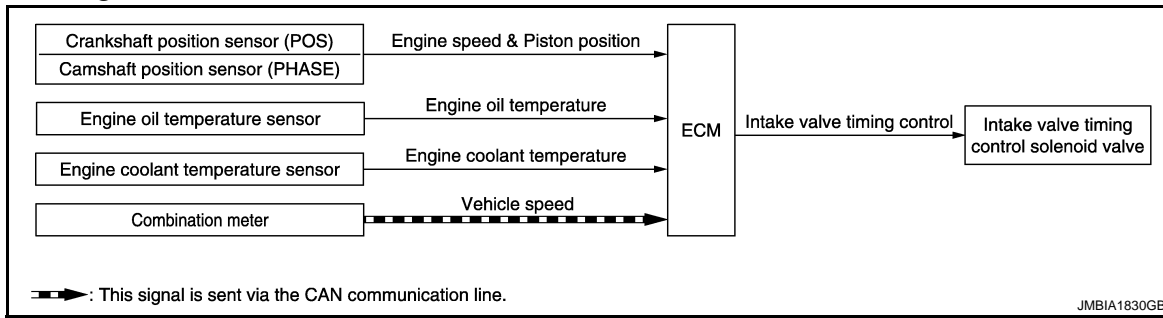

System Description

INFOID:000000003387919

INPUT/OUTPUT SIGNAL CHART

Sensor	Input signal to ECM	ECM function	Actuator
Crankshaft position sensor (POS)	Engine speed and piston position	Intake valve timing control	Intake valve timing control solenoid valve
Camshaft position sensor (PHASE)			
Engine oil temperature sensor	Engine oil temperature		
Engine coolant temperature sensor	Engine coolant temperature		
Combination meter	Vehicle speed*		

*: This signal is sent to the ECM via the CAN communication line

SYSTEM DESCRIPTION

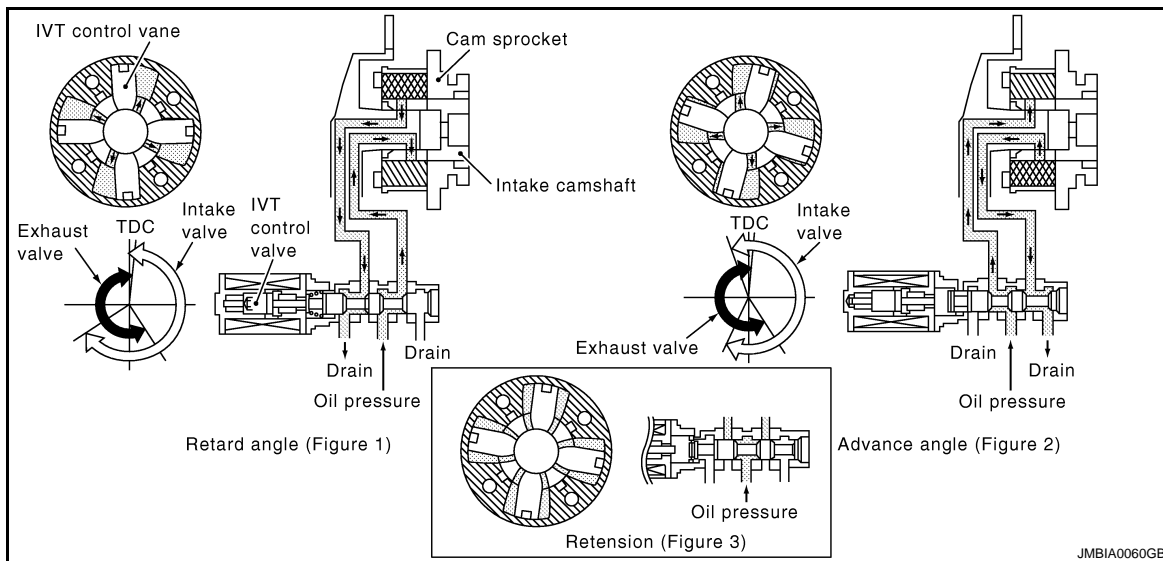

This mechanism hydraulically controls cam phases continuously with the fixed operating angle of the intake valve.

The ECM receives signals such as crankshaft position, camshaft position, engine speed, and engine coolant temperature. Then, the ECM sends ON/OFF pulse duty signals to the intake valve timing (IVT) control solenoid valve depending on driving status. This makes it possible to control the shut/open timing of the intake valve to increase engine torque in low/mid speed range and output in high-speed range.

INTAKE VALVE TIMING CONTROL

< FUNCTION DIAGNOSIS >

[VQ35DE]

Component Parts Location

INFOID:000000003573792

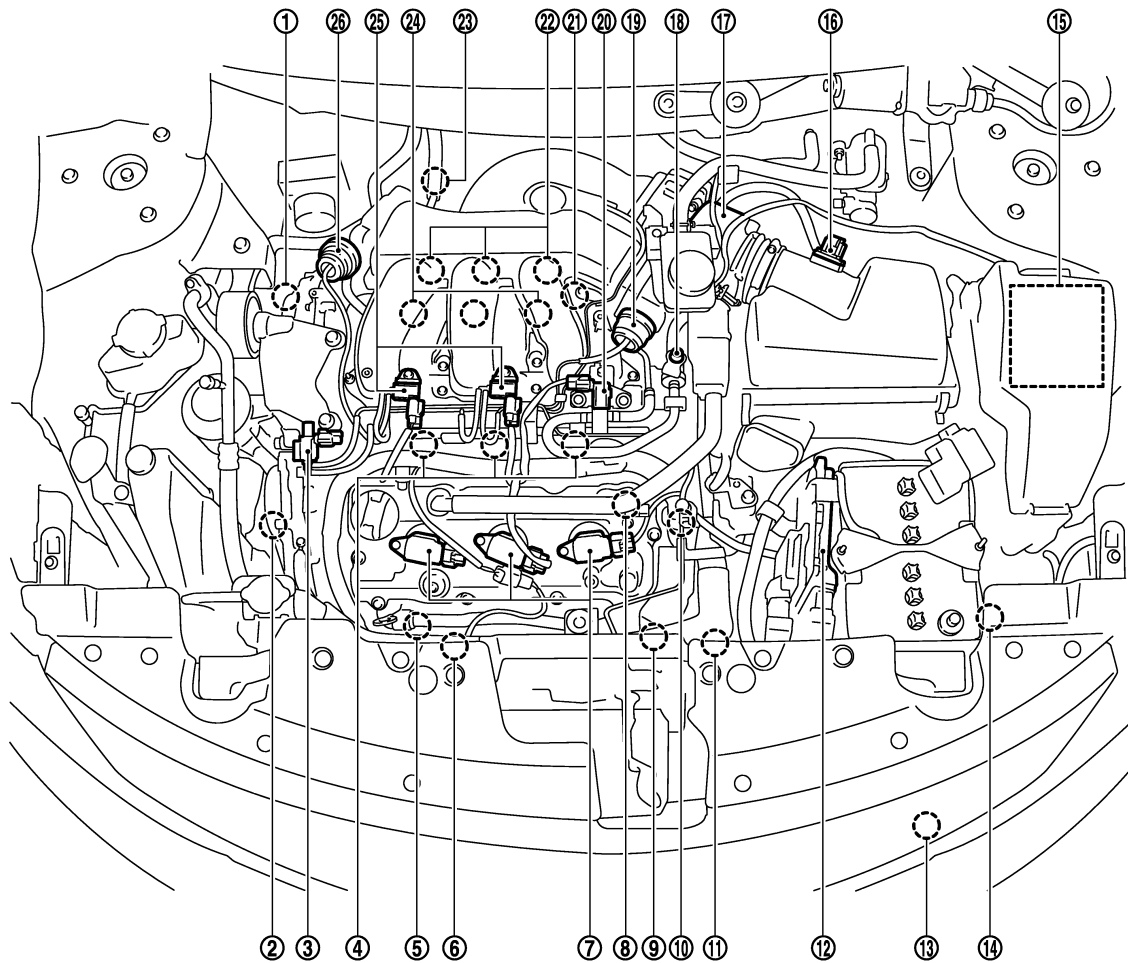

JMBIA1108ZZ

- | | | |
|---|--|--|
| 1. Intake valve timing control solenoid valve (bank 1) | 2. Intake valve timing control solenoid valve (bank 2) | 3. Electronic controlled engine mount control solenoid valve |
| 4. Fuel injector (bank 2) | 5. A/F sensor 1 (bank 2) | 6. Cooling fan motor-2 |
| 7. Ignition coil (with power transistor) and spark plug (bank 2) | 8. Camshaft position sensor (PHASE) (bank 2) | 9. Crankshaft position sensor (POS) |
| 10. Engine coolant temperature sensor | 11. Cooling fan motor-1 | 12. ECM |
| 13. Refrigerant pressure sensor | 14. Battery current sensor | 15. IPDM E/R |
| 16. Mass air flow sensor (with intake air temperature sensor) | 17. Electric throttle control actuator | 18. EVAP service port |
| 19. Power valve actuator 2 | 20. EVAP canister purge volume control solenoid valve | 21. Camshaft position sensor (PHASE) (bank 1) |
| 22. Ignition coil (with power transistor) and spark plug (bank 1) | 23. A/F sensor 1 (bank 1) | 24. Fuel injector (bank 1) |
| 25. VIAS control solenoid valve 1 and 2 | 26. Power valve actuator 1 | |

INTAKE VALVE TIMING CONTROL

< FUNCTION DIAGNOSIS >

[VQ35DE]

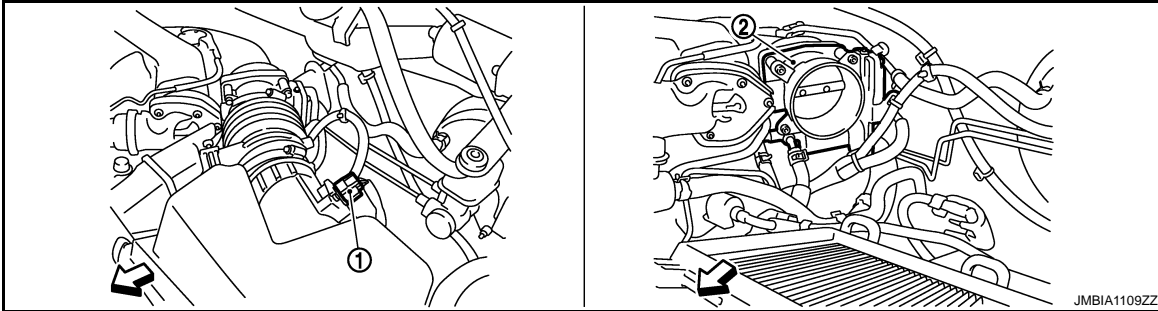

- 1. Mass air flow sensor (with intake air temperature sensor)
- 2. Electric throttle control actuator

← : Vehicle front

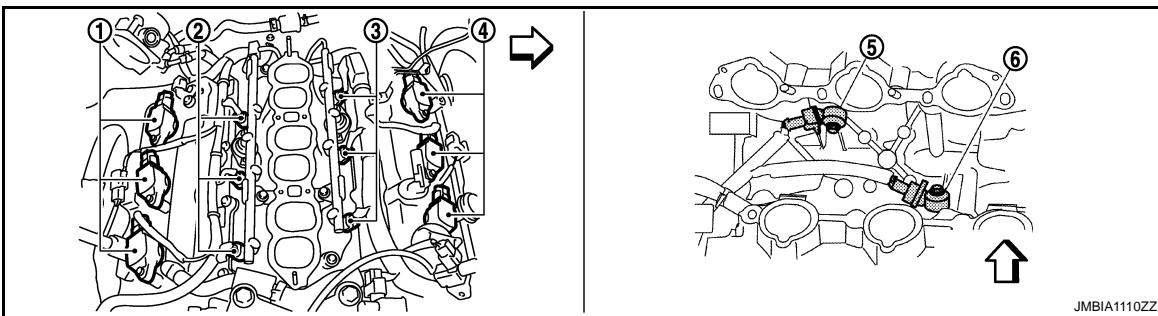

- 1. Ignition coil (with power transistor and spark plug (bank 1))
- 2. Fuel injector (bank 1)
- 3. Fuel injector (bank 2)
- 4. Ignition coil (with power transistor and spark plug (bank 2))
- 5. Knock sensor (bank 2)
- 6. Knock sensor (bank 1)

← : Vehicle front

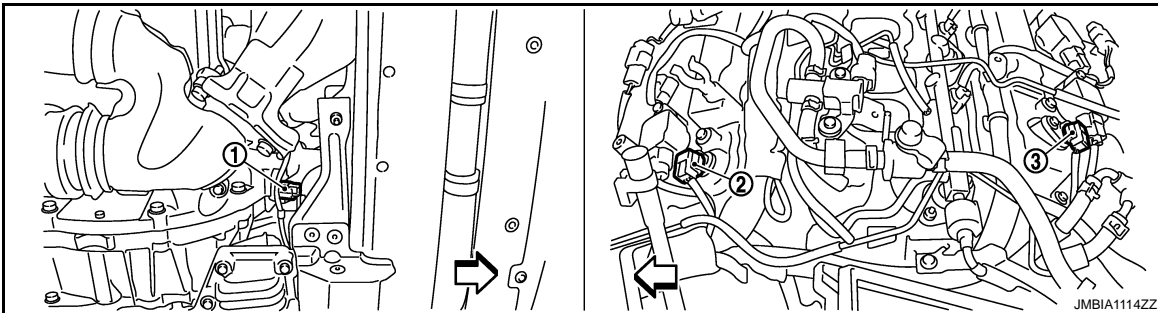

- 1. Crankshaft position sensor (POS)
- 2. Camshaft position sensor (PHASE) (bank 1)
- 3. Camshaft position sensor (PHASE) (bank 2)

← : Vehicle front

A
EC
C
D
E
F
G
H
I
J
K
L
M
N
O
P

INTAKE VALVE TIMING CONTROL

< FUNCTION DIAGNOSIS >

[VQ35DE]

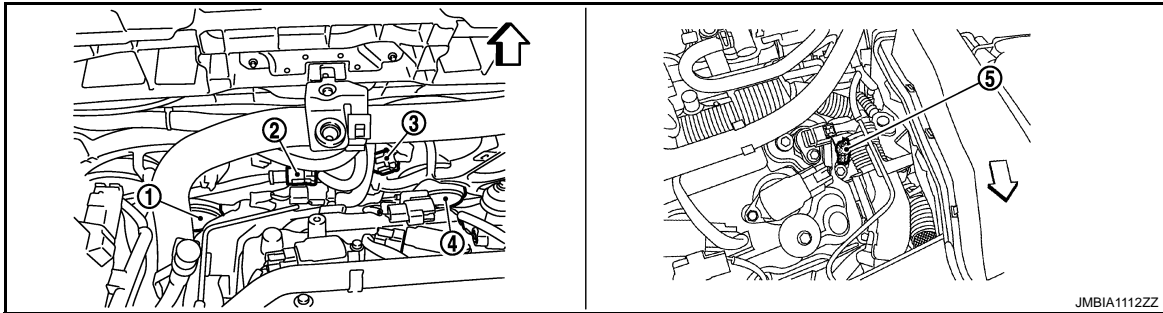

- 1. Cooling fan motor-1
- 2. Cooling fan motor-1 harness connector
- 3. Cooling fan motor-1 harness connector
- 4. Cooling fan motor-2
- 5. Engine coolant temperature sensor

↙ : Vehicle front

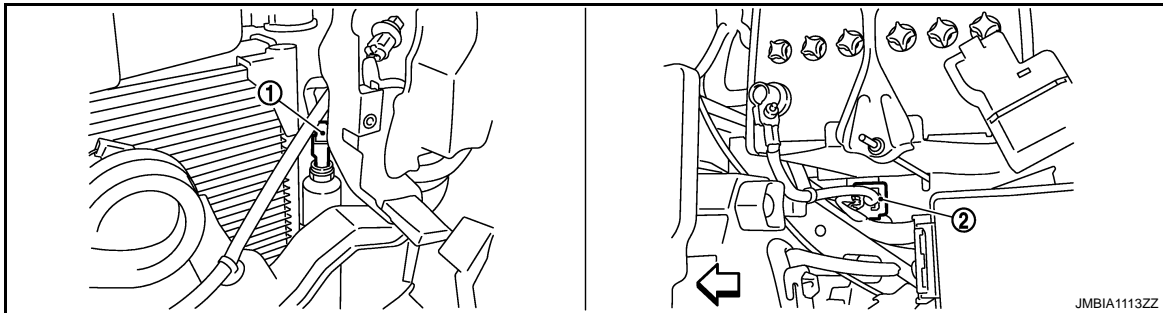

- 1. Refrigerant pressure sensor
- 2. Battery current sensor

↙ : Vehicle front

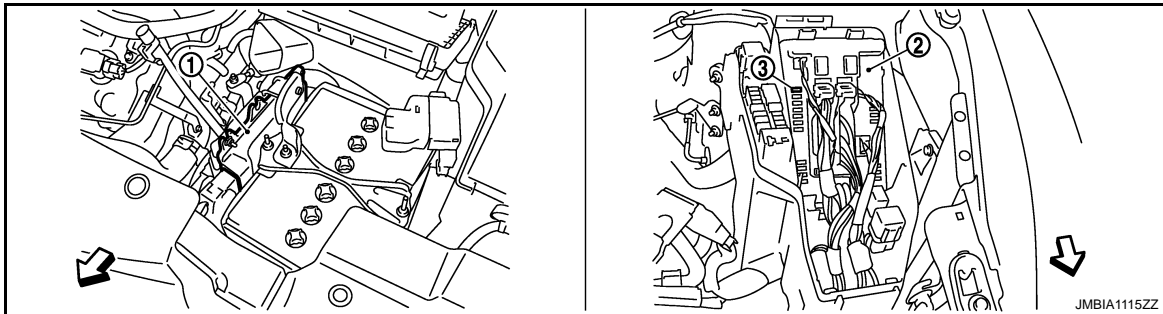

- 1. ECM
- 2. IPDM E/R
- 3. Fuel pump fuse

↙ : Vehicle front

INTAKE VALVE TIMING CONTROL

< FUNCTION DIAGNOSIS >

[VQ35DE]

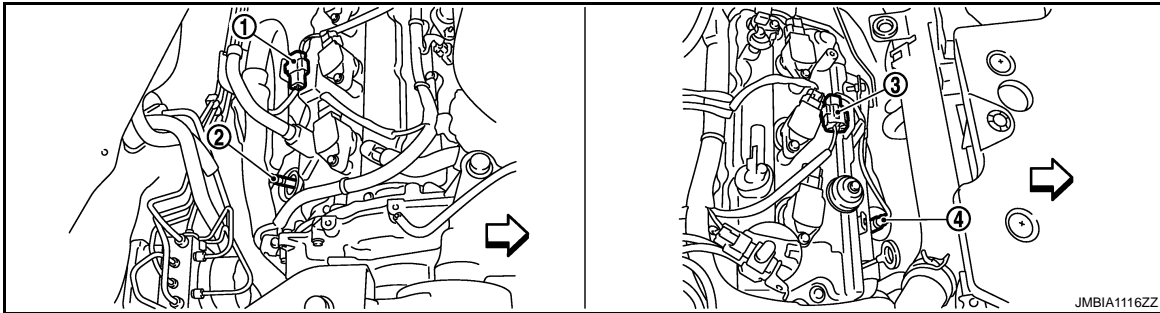
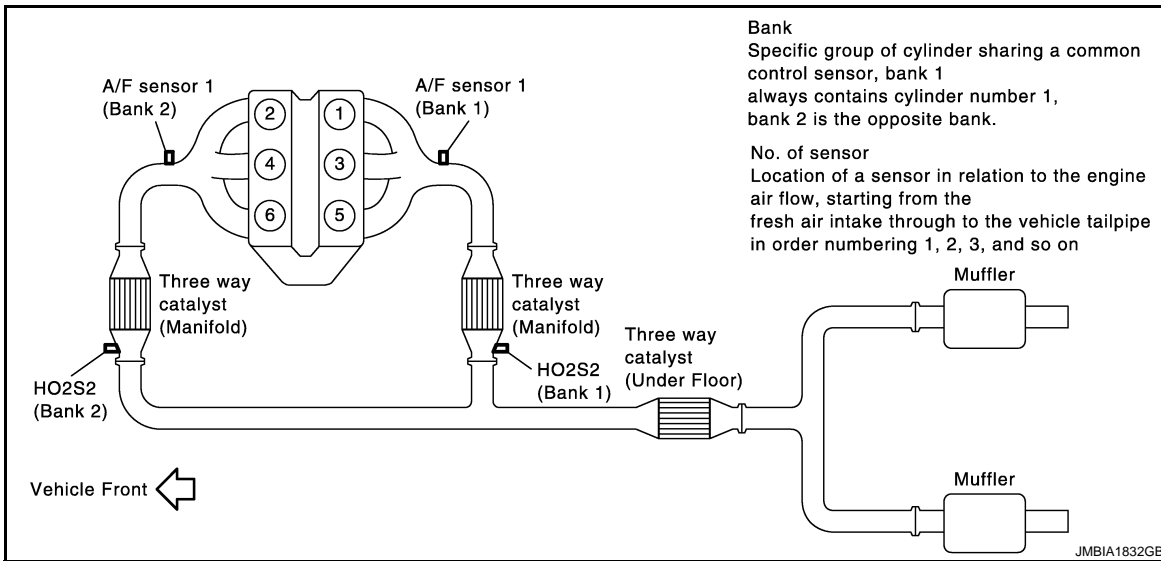

1. A/F sensor 1 (bank 1) harness connector 2. A/F sensor 1 (bank 1)
3. A/F sensor 1 (bank 2) harness connector

4. A/F sensor 1 (bank 2)

← : Vehicle front

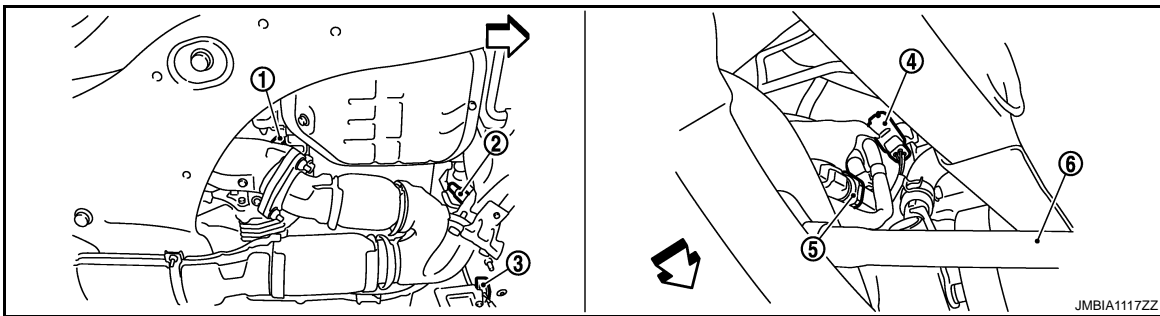

1. HO2S2 (bank 1) 2. HO2S2 (bank 2) 3. HO2S2 (bank 2) harness connector
4. HO2S2 (bank 1) harness connector 5. Power steering pressure sensor 6. Drive shaft (RH)

← : Vehicle front

INTAKE VALVE TIMING CONTROL

< FUNCTION DIAGNOSIS >

[VQ35DE]

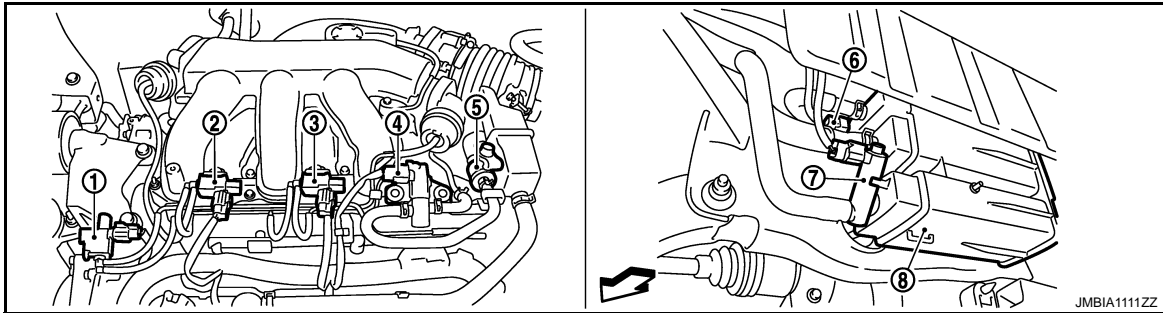

- 1. Electronic controlled engine mount control solenoid valve
- 2. VIAS control solenoid valve 1
- 3. VIAS control solenoid valve 2
- 4. EVAP canister purge volume control solenoid valve
- 5. EVAP service port
- 6. EVAP control system pressure sensor
- 7. EVAP canister vent control valve
- 8. EVAP canister

↶ : Vehicle front

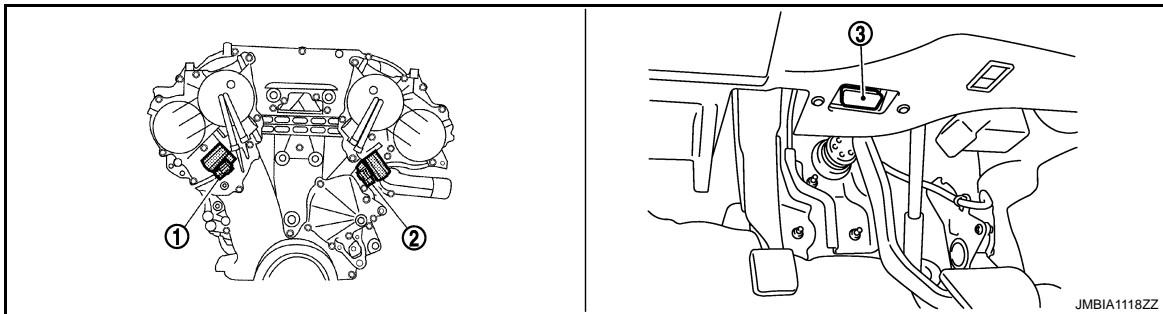

- 1. Intake valve timing control solenoid valve (bank 1)
- 2. Intake valve timing control solenoid valve (bank 2)
- 3. Data link connector

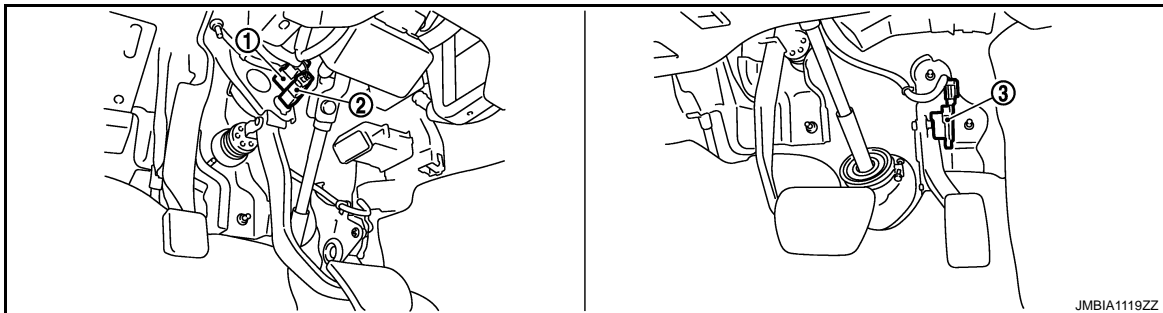

- 1. Stop lamp switch
- 2. ASCD brake switch
- 3. Accelerator pedal position sensor

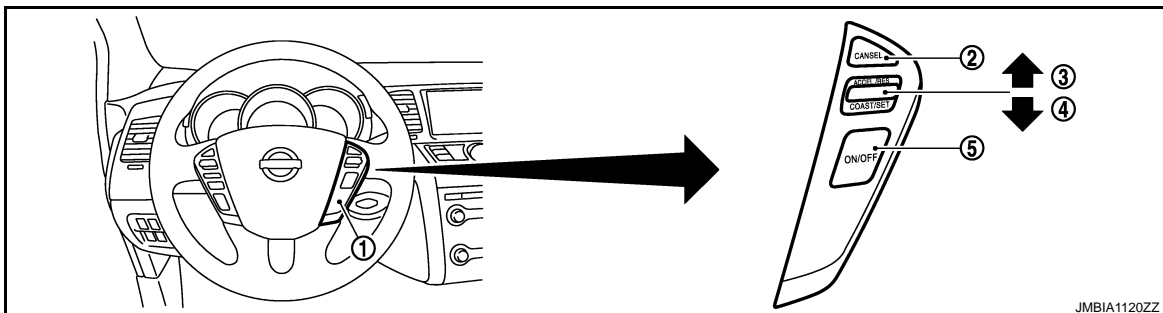

INTAKE VALVE TIMING CONTROL

< FUNCTION DIAGNOSIS >

[VQ35DE]

- | | | |
|-------------------------|------------------|-----------------------------|
| 1. ASCD steering switch | 2. CANCEL switch | 3. RESUME/ACCELERATE switch |
| 4. SET/COAST switch | 5. MAIN switch | |

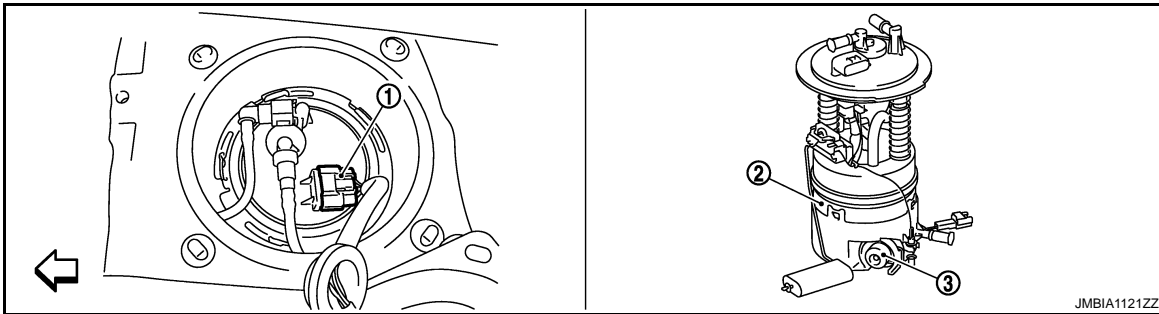

1. Fuel level sensor unit and fuel pump harness connector 2. Fuel level sensor unit and fuel pump 3. Fuel pressure regulator

← : Vehicle front

Component Description

INFOID:000000003387921

Component	Reference
Camshaft position sensor (PHASE)	EC-264. "Description"
Crankshaft position sensor (POS)	EC-260. "Description"
Engine coolant temperature sensor	EC-170. "Description"
Engine oil temperature sensor	EC-242. "Description"
Intake valve timing control solenoid valve	EC-151. "Description"

VARIABLE INDUCTION AIR SYSTEM

< FUNCTION DIAGNOSIS >

[VQ35DE]

VARIABLE INDUCTION AIR SYSTEM

System Diagram

INFOID:000000003387922

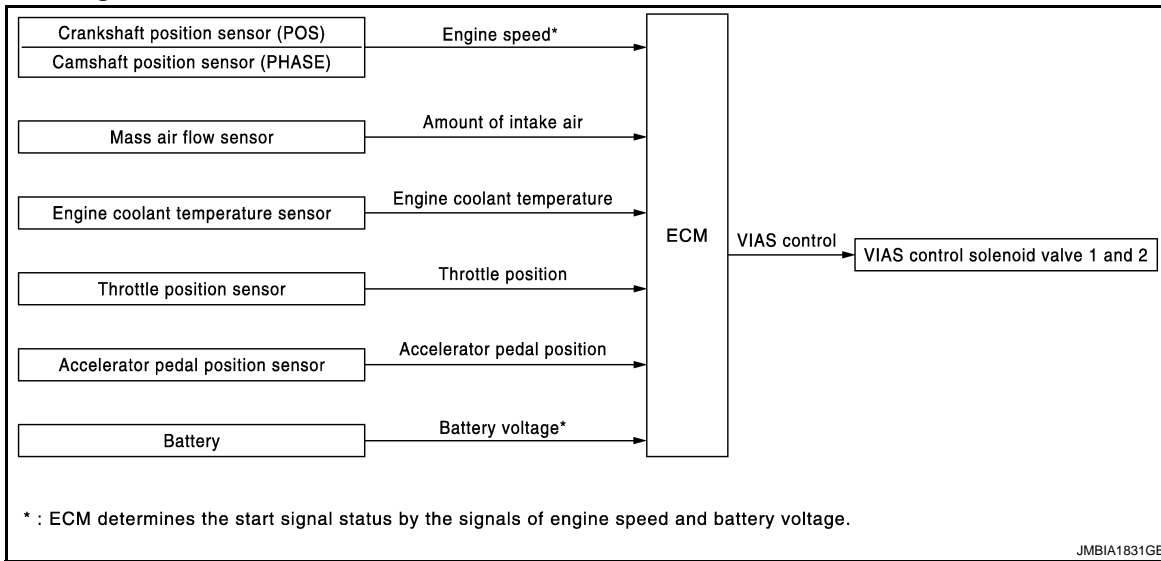

JMBIA1831GB

System Description

INFOID:000000003387923

INPUT/OUTPUT SIGNAL CHART

Sensor	Input signal to ECM	ECM function	Actuator
Crankshaft position sensor (POS) Camshaft position sensor (PHASE)	Engine speed*	VIAS control	VIAS control solenoid valve 1 VIAS control solenoid valve 2
Mass air flow sensor	Amount of intake air		
Engine coolant temperature sensor	Engine coolant temperature		
Throttle position sensor	Throttle position		
Accelerator pedal position sensor	Accelerator pedal position		
Battery	Battery voltage*		

*: ECM determines the start signal status by the signals of engine speed and battery voltage.

SYSTEM DESCRIPTION

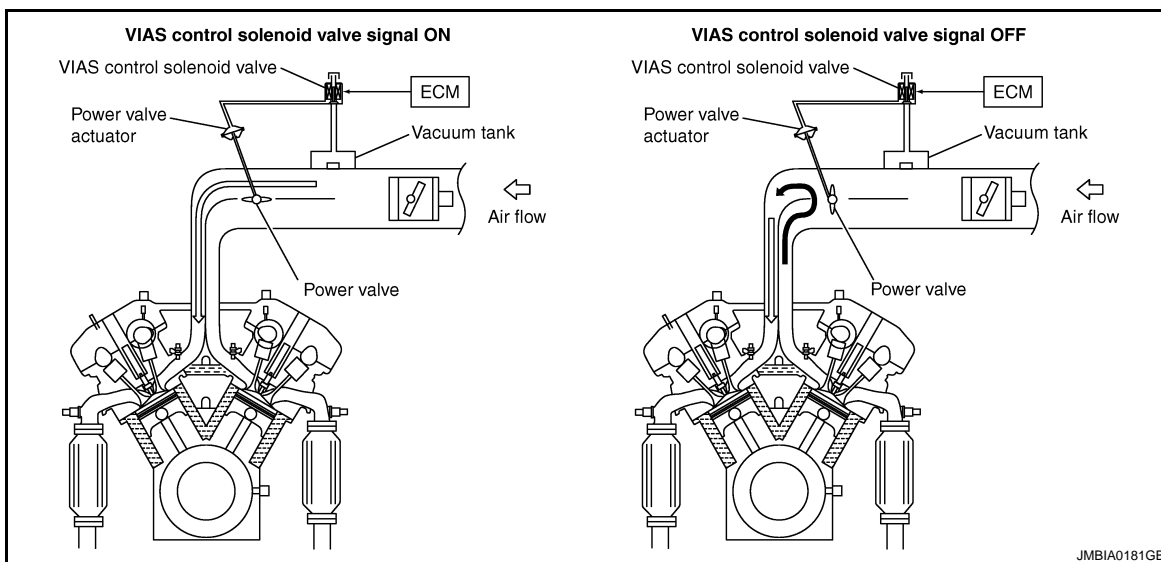

JMBIA0181GB

In the medium speed range, the ECM sends the ON signal to the VIAS control solenoid valve. This signal introduces the intake manifold vacuum into the power valve actuator and therefore closes the power valve.

VARIABLE INDUCTION AIR SYSTEM

< FUNCTION DIAGNOSIS >

[VQ35DE]

Under this condition, the pressure waves of the exhaust stroke do not disturb the pressure waves of the intake stroke of each opposite bank. Therefore, charging efficiency is increased together with the effect of the long intake passage.

However, in the high speed range, the ECM sends the OFF signal to the VIAS control solenoid valve and the power valve is opened. Under this condition, the pressure waves of intake stroke are resonant with those of each opposite bank exhaust stroke. Therefore, charging efficiency is also increased.

In addition, both valves 1 and 2 are opened or closed in other ranges mentioned above. Thus maximum charging efficiency is obtained for the various driving conditions.

VACUUM HOSE DRAWING

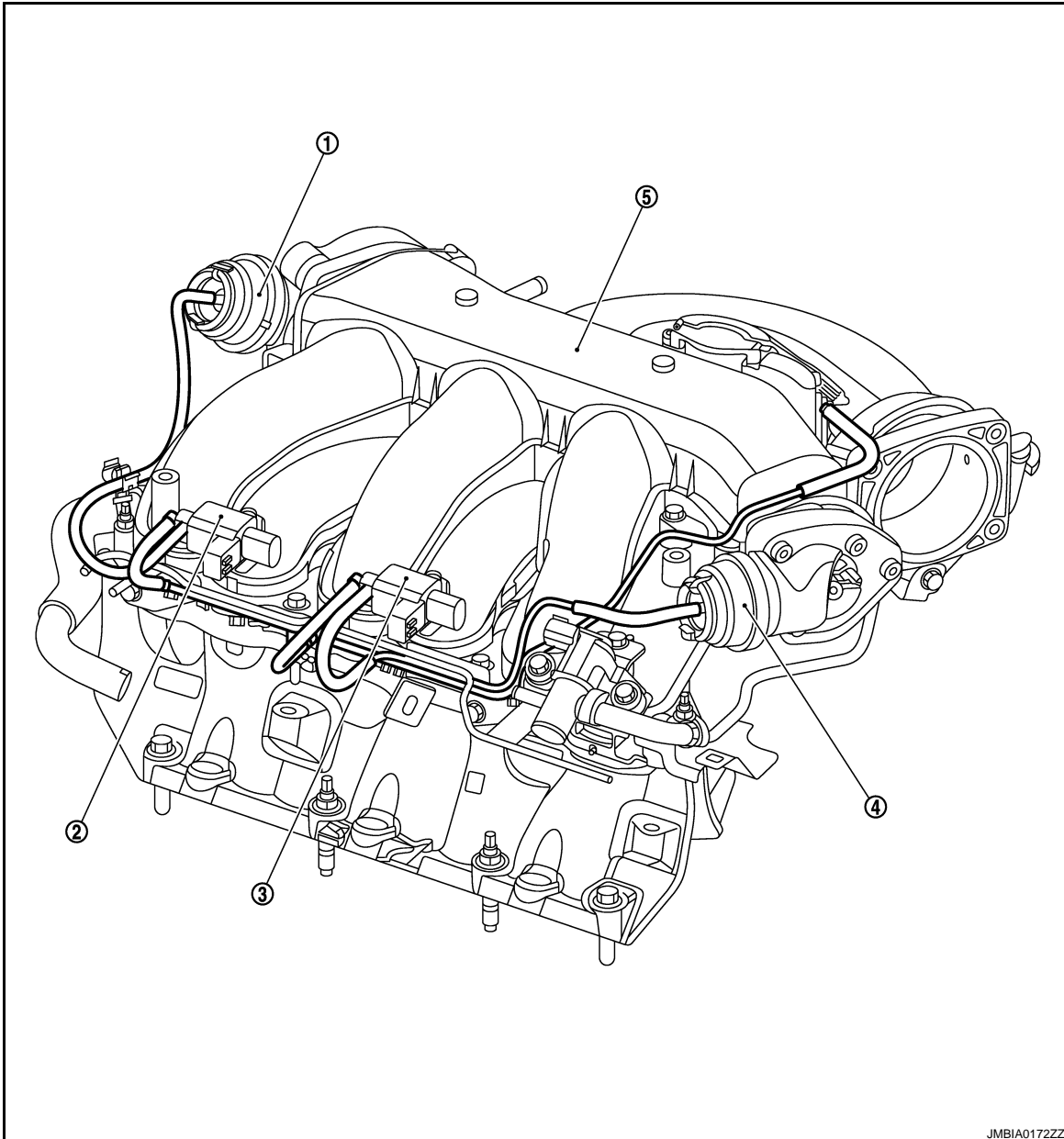

- | | | |
|---------------------------|----------------------------------|----------------------------------|
| 1. Power valve actuator 1 | 2. VIAS control solenoid valve 1 | 3. VIAS control solenoid valve 2 |
| 4. Power valve actuator 2 | 5. Intake manifold collector | |

VARIABLE INDUCTION AIR SYSTEM

< FUNCTION DIAGNOSIS >

[VQ35DE]

Component Parts Location

INFOID:000000003573795

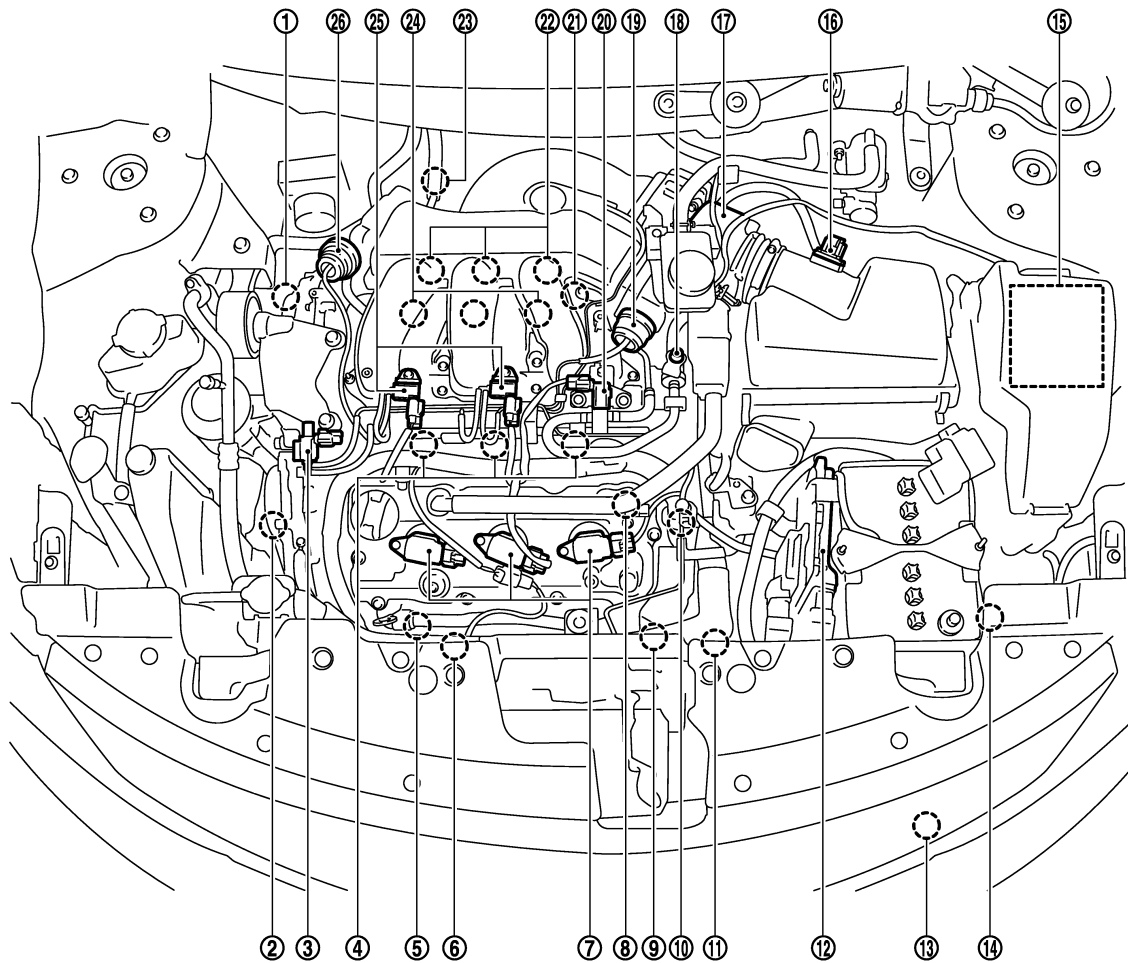

JMBIA1108ZZ

- | | | |
|---|--|--|
| 1. Intake valve timing control solenoid valve (bank 1) | 2. Intake valve timing control solenoid valve (bank 2) | 3. Electronic controlled engine mount control solenoid valve |
| 4. Fuel injector (bank 2) | 5. A/F sensor 1 (bank 2) | 6. Cooling fan motor-2 |
| 7. Ignition coil (with power transistor) and spark plug (bank 2) | 8. Camshaft position sensor (PHASE) (bank 2) | 9. Crankshaft position sensor (POS) |
| 10. Engine coolant temperature sensor | 11. Cooling fan motor-1 | 12. ECM |
| 13. Refrigerant pressure sensor | 14. Battery current sensor | 15. IPDM E/R |
| 16. Mass air flow sensor (with intake air temperature sensor) | 17. Electric throttle control actuator | 18. EVAP service port |
| 19. Power valve actuator 2 | 20. EVAP canister purge volume control solenoid valve | 21. Camshaft position sensor (PHASE) (bank 1) |
| 22. Ignition coil (with power transistor) and spark plug (bank 1) | 23. A/F sensor 1 (bank 1) | 24. Fuel injector (bank 1) |
| 25. VIAS control solenoid valve 1 and 2 | 26. Power valve actuator 1 | |

VARIABLE INDUCTION AIR SYSTEM

< FUNCTION DIAGNOSIS >

[VQ35DE]

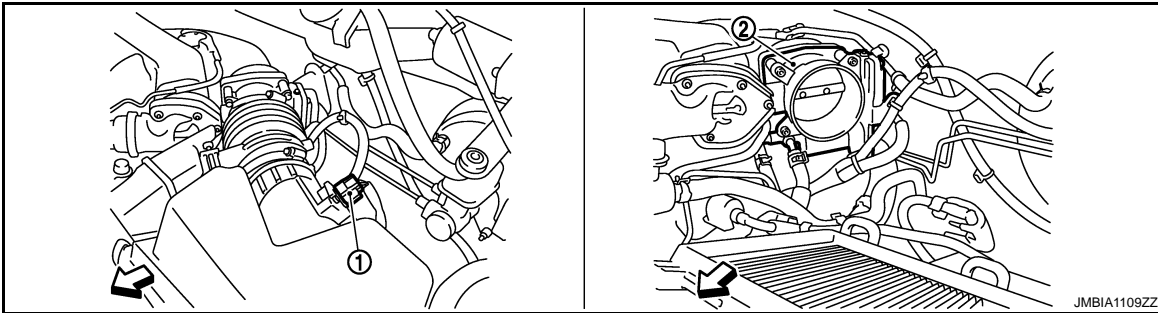

- 1. Mas air flow sensor (with intake air temperature sensor)
- 2. Electric throttle control actuator

← : Vehicle front

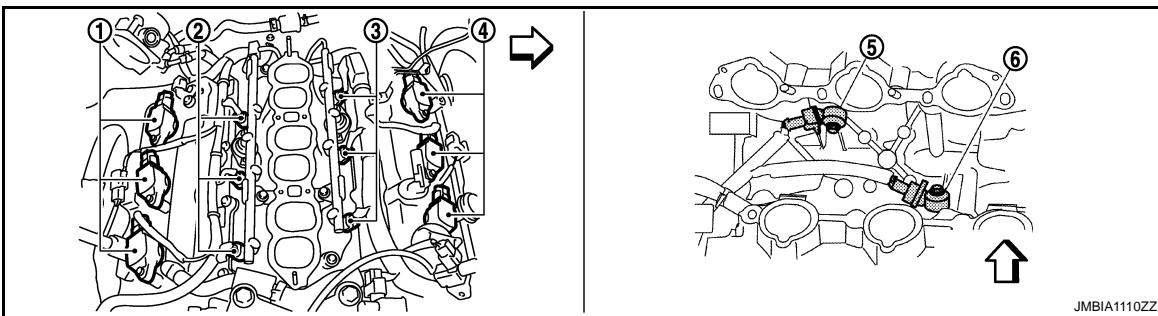

- 1. Ignition coil (with power transistor and spark plug (bank 1))
- 2. Fuel injector (bank 1)
- 3. Fuel injector (bank 2)
- 4. Ignition coil (with power transistor and spark plug (bank 2))
- 5. Knock sensor (bank 2)
- 6. Knock sensor (bank 1)

← : Vehicle front

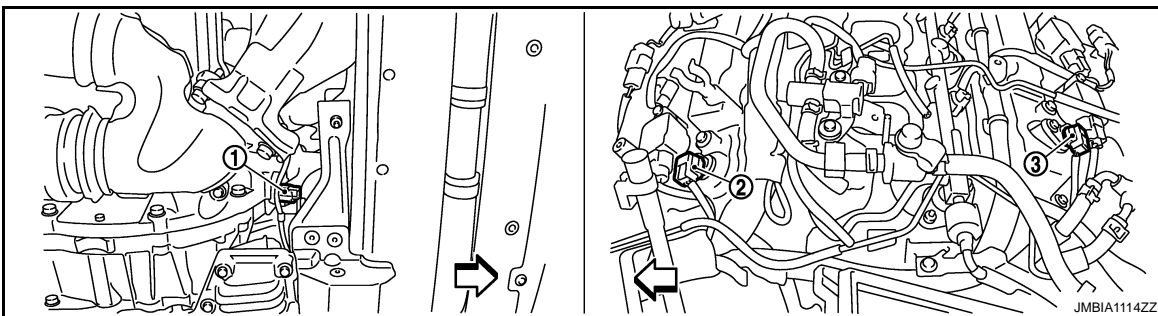

- 1. Crankshaft position sensor (POS)
- 2. Camshaft position sensor (PHASE) (bank 1)
- 3. Camshaft position sensor (PHASE) (bank 2)

← : Vehicle front

A

EC

C

D

E

F

G

H

I

J

K

L

M

N

O

P

VARIABLE INDUCTION AIR SYSTEM

< FUNCTION DIAGNOSIS >

[VQ35DE]

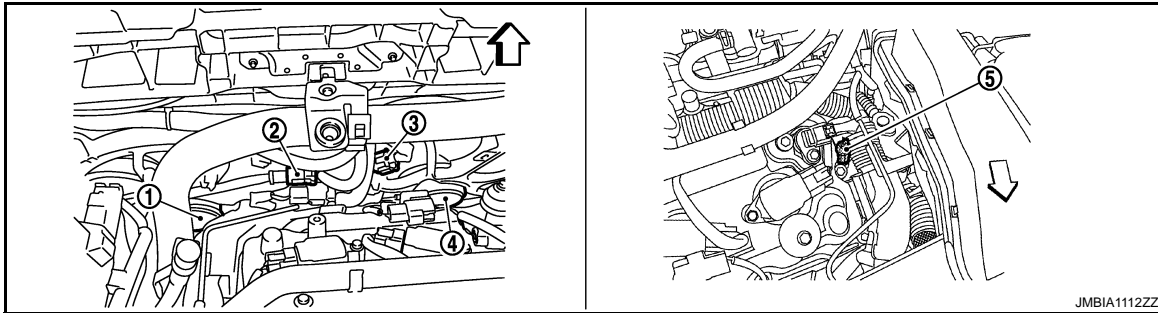

- 1. Cooling fan motor-1
- 2. Cooling fan motor-1 harness connector
- 3. Cooling fan motor-1 harness connector
- 4. Cooling fan motor-2
- 5. Engine coolant temperature sensor

↙ : Vehicle front

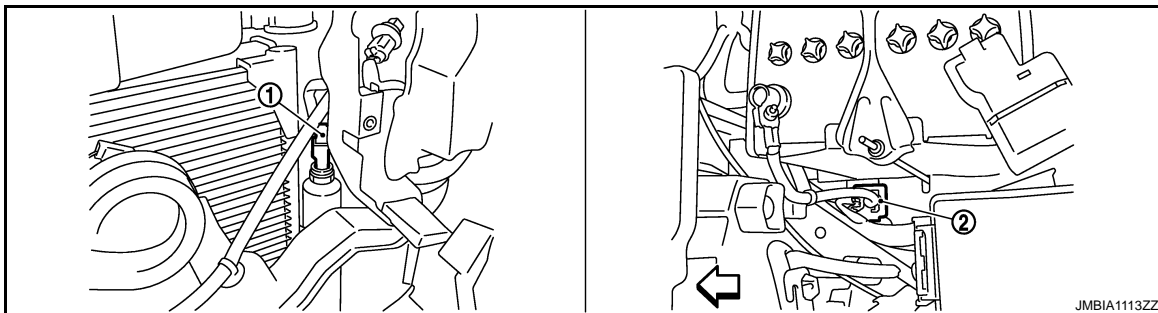

- 1. Refrigerant pressure sensor
- 2. Battery current sensor

↙ : Vehicle front

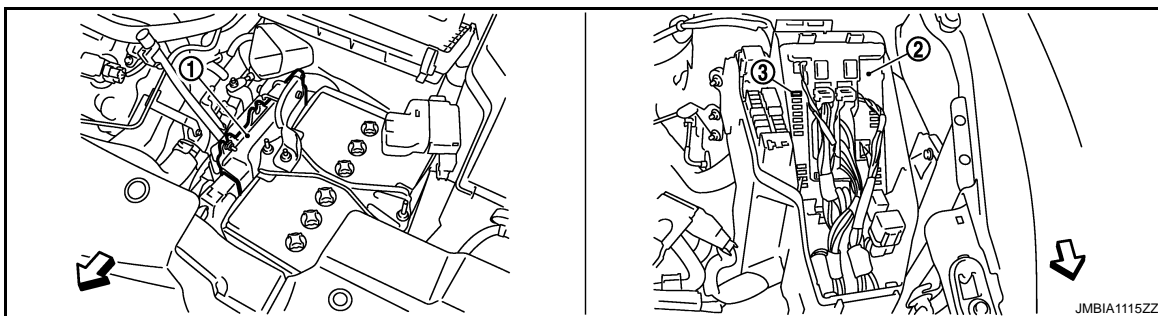

- 1. ECM
- 2. IPDM E/R
- 3. Fuel pump fuse

↙ : Vehicle front

VARIABLE INDUCTION AIR SYSTEM

< FUNCTION DIAGNOSIS >

[VQ35DE]

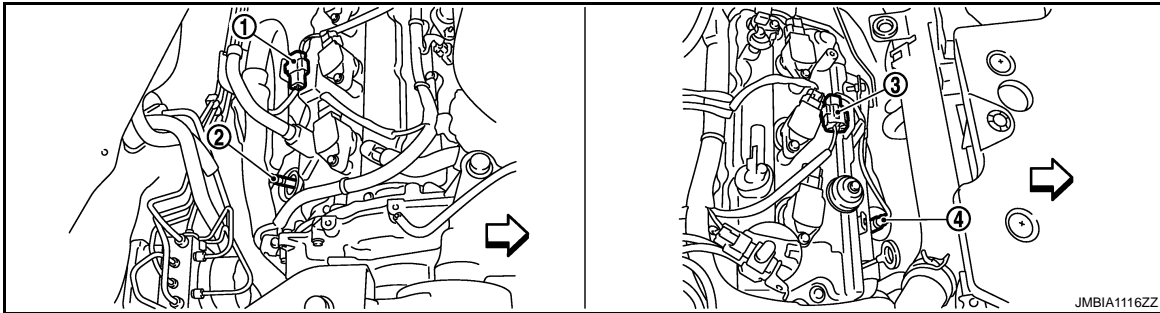
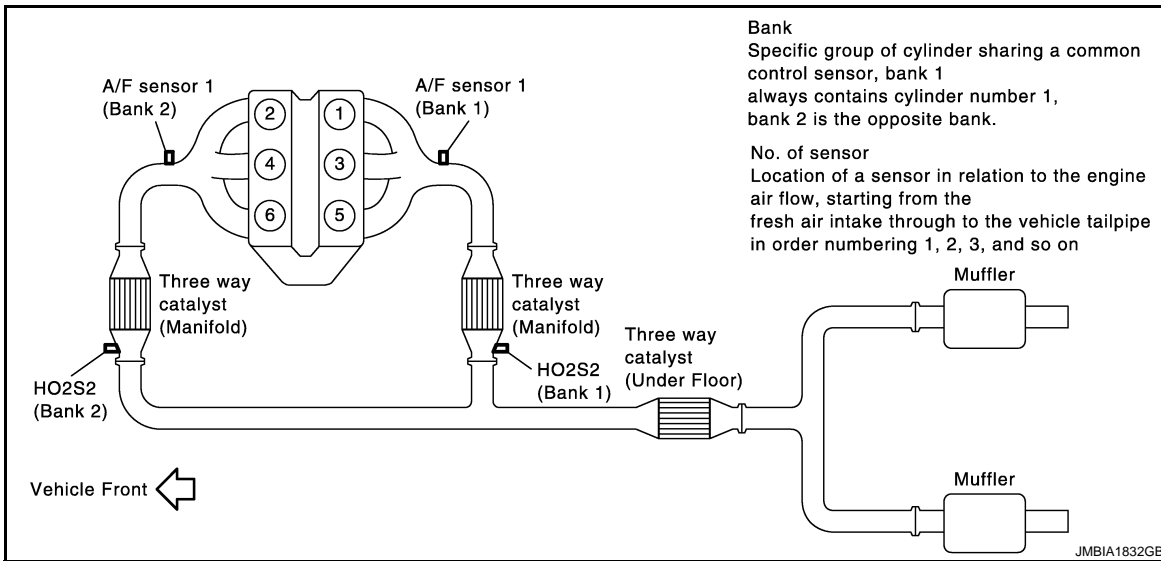

1. A/F sensor 1 (bank 1) harness connector
 2. A/F sensor 1 (bank 1)
 3. A/F sensor 1 (bank 2) harness connector
 4. A/F sensor 1 (bank 2)
- ← : Vehicle front

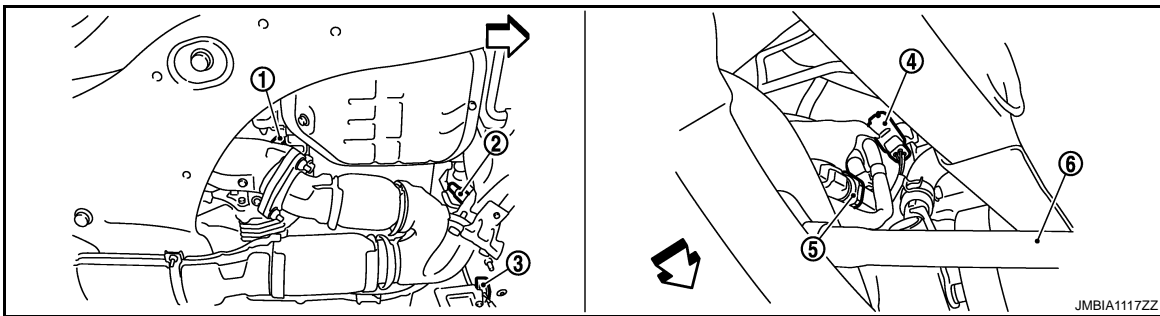

1. HO2S2 (bank 1)
 2. HO2S2 (bank 2)
 3. HO2S2 (bank 2) harness connector
 4. HO2S2 (bank 1) harness connector
 5. Power steering pressure sensor
 6. Drive shaft (RH)
- ← : Vehicle front

A
EC
C
D
E
F
G
H
I
J
K
L
M
N
O
P

VARIABLE INDUCTION AIR SYSTEM

< FUNCTION DIAGNOSIS >

[VQ35DE]

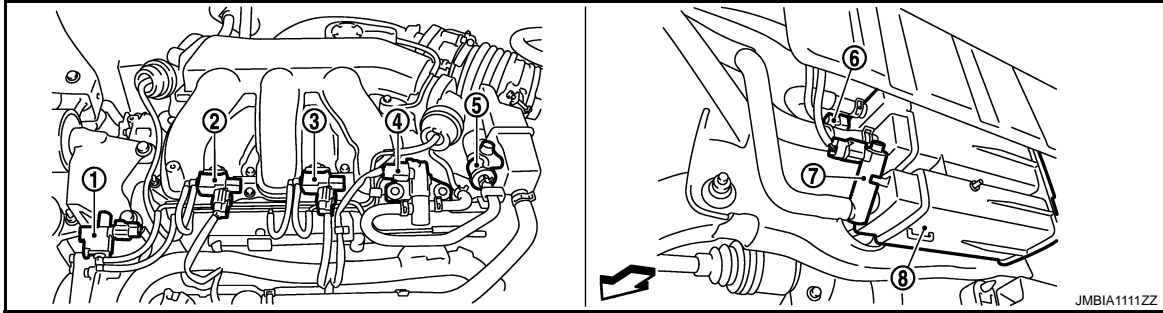

- | | | |
|--|----------------------------------|--|
| 1. Electronic controlled engine mount control solenoid valve | 2. VIAS control solenoid valve 1 | 3. VIAS control solenoid valve 2 |
| 4. EVAP canister purge volume control solenoid valve | 5. EVAP service port | 6. EVAP control system pressure sensor |
| 7. EVAP canister vent control valve | 8. EVAP canister | |

↶ : Vehicle front

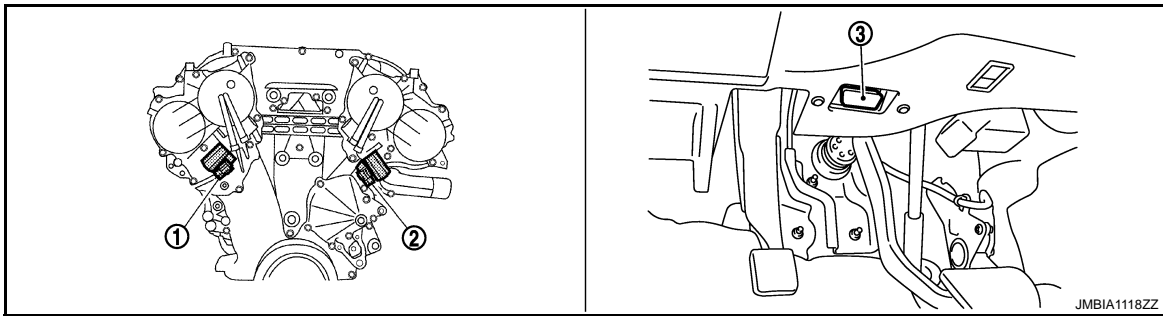

- | | | |
|--|--|------------------------------|
| 1. Intake valve timing control solenoid valve (bank 1) | 2. Intake valve timing control solenoid valve (bank 2) | 3. Data link connector valve |
|--|--|------------------------------|

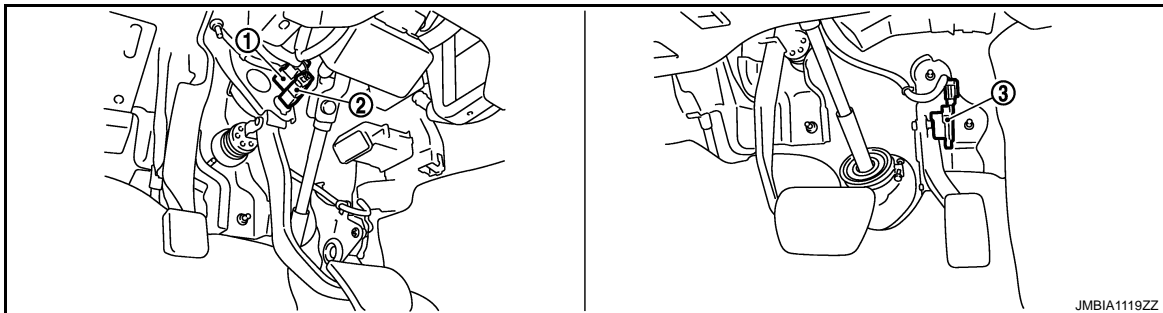

- | | | |
|---------------------|----------------------|--------------------------------------|
| 1. Stop lamp switch | 2. ASCD brake switch | 3. Accelerator pedal position sensor |
|---------------------|----------------------|--------------------------------------|

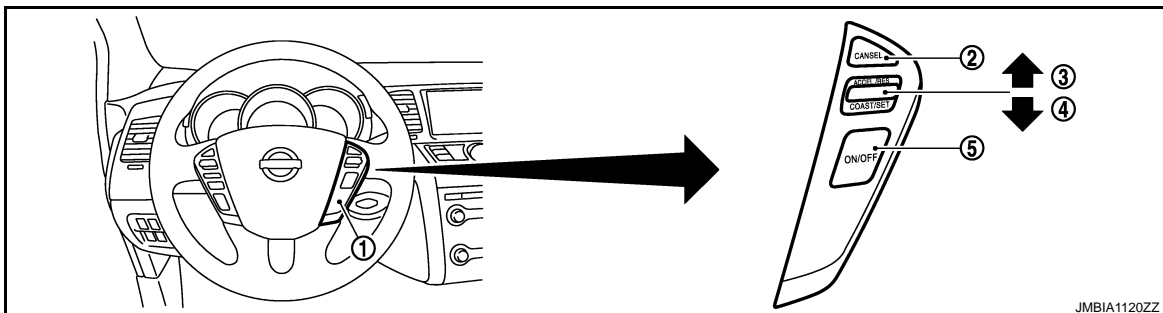

VARIABLE INDUCTION AIR SYSTEM

< FUNCTION DIAGNOSIS >

[VQ35DE]

- | | | |
|-------------------------|------------------|-----------------------------|
| 1. ASCD steering switch | 2. CANCEL switch | 3. RESUME/ACCELERATE switch |
| 4. SET/COAST switch | 5. MAIN switch | |

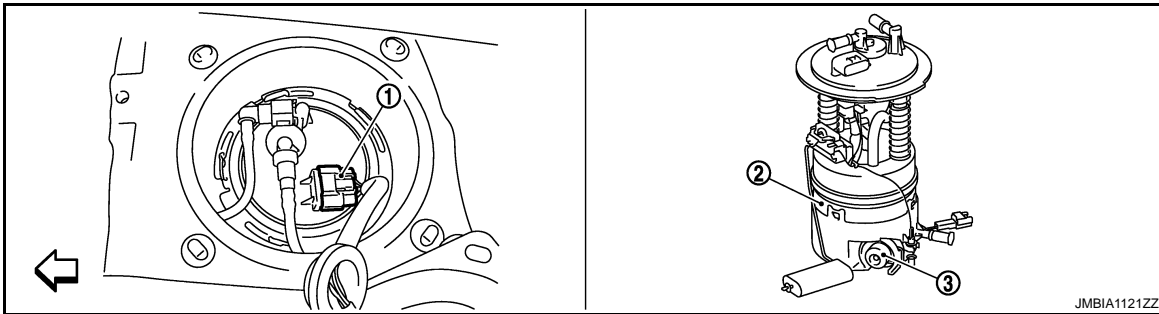

1. Fuel level sensor unit and fuel pump 2. Fuel level sensor unit and fuel pump 3. Fuel pressure regulator harness connector

← : Vehicle front

Component Description

INFOID:000000003387925

Component	Reference
Accelerator pedal position sensor	EC-413, "Description"
Camshaft position sensor (PHASE)	EC-264, "Description"
Crankshaft position sensor (POS)	EC-260, "Description"
Engine coolant temperature sensor	EC-170, "Description"
Mass air flow sensor	EC-154, "Description"
Power valve 1 and 2	EC-466, "Description"
Throttle position sensor	EC-175, "Description"
VIAS control solenoid valve 1	EC-393, "Description"
VIAS control solenoid valve 2	EC-396, "Description"

ON BOARD DIAGNOSTIC (OBD) SYSTEM

< FUNCTION DIAGNOSIS >

[VQ35DE]

ON BOARD DIAGNOSTIC (OBD) SYSTEM

Diagnosis Description

INFOID:000000003387926

INTRODUCTION

The ECM has an on board diagnostic system, which detects malfunctions related to engine sensors or actuators. The ECM also records various emission-related diagnostic information including:

Emission-related diagnostic information	Diagnostic service
Diagnostic Trouble Code (DTC)	Service \$03 of SAE J1979
Freeze Frame data	Service \$02 of SAE J1979
System Readiness Test (SRT) code	Service \$01 of SAE J1979
1st Trip Diagnostic Trouble Code (1st Trip DTC)	Service \$07 of SAE J1979
1st Trip Freeze Frame data	—
Test values and Test limits	Service \$06 of SAE J1979
Calibration ID	Service \$09 of SAE J1979

The above information can be checked using procedures listed in the table below.

×: Applicable —: Not applicable

	DTC	1st trip DTC	Freeze Frame data	1st trip Freeze Frame data	SRT code	SRT status	Test value
CONSULT-III	×	×	×	×	×	×	—
GST	×	×	×	—	×	×	×
ECM	×	×*	—	—	—	×	—

*: When DTC and 1st trip DTC simultaneously appear on the display, they cannot be clearly distinguished from each other.

The malfunction indicator lamp (MIL) on the instrument panel illuminates when the same malfunction is detected in two consecutive trips (Two trip detection logic), or when the ECM enters fail-safe mode. (Refer to [EC-517, "Fail-safe".](#))

TWO TRIP DETECTION LOGIC

When a malfunction is detected for the 1st time, 1st trip DTC and 1st trip Freeze Frame data are stored in the ECM memory. The MIL will not illuminate at this stage. <1st trip>

If the same malfunction is detected again during the next drive, the DTC and Freeze Frame data are stored in the ECM memory, and the MIL illuminates. The MIL illuminates at the same time when the DTC is stored. <2nd trip> The "trip" in the "Two Trip Detection Logic" means a driving mode in which self-diagnosis is performed during vehicle operation. Specific on board diagnostic items will cause the ECM to illuminate or blink the MIL, and store DTC and Freeze Frame data, even in the 1st trip, as shown below.

×: Applicable —: Not applicable

Items	MIL				DTC		1st trip DTC	
	1st trip		2nd trip		1st trip displaying	2nd trip displaying	1st trip displaying	2nd trip displaying
	Blinking	illuminate	Blinking	illuminate				
Misfire (Possible three way catalyst damage) — DTC: P0300 - P0306 is being detected	×	—	—	—	—	—	×	—
Misfire (Possible three way catalyst damage) — DTC: P0300 - P0306 is being detected	—	—	×	—	—	×	—	—
One trip detection diagnoses (Refer to EC-521, "DTC Index".)	—	×	—	—	×	—	—	—
Except above	—	—	—	×	—	×	×	—

DTC AND FREEZE FRAME DATA

DTC and 1st Trip DTC

ON BOARD DIAGNOSTIC (OBD) SYSTEM

[VQ35DE]

< FUNCTION DIAGNOSIS >

The 1st trip DTC (whose number is the same as the DTC number) is displayed for the latest self-diagnostic result obtained. If the ECM memory was cleared previously, and the 1st trip DTC did not recur, the 1st trip DTC will not be displayed.

If a malfunction is detected during the 1st trip, the 1st trip DTC is saved in the ECM memory. The MIL will not illuminate (two trip detection logic). If the same malfunction is not detected in the 2nd trip (meeting the required driving pattern), the 1st trip DTC is cleared from the ECM memory. If the same malfunction is detected in the 2nd trip, both the 1st trip DTC and DTC are stored in the ECM memory and the MIL illuminates. In other words, the DTC is stored in the ECM memory and the MIL illuminates when the same malfunction occurs in two consecutive trips. If a 1st trip DTC is saved and a non-diagnostic operation is performed between the 1st and 2nd trips, only the 1st trip DTC will continue to be stored. For malfunctions that blink or illuminate the MIL during the 1st trip, the DTC and 1st trip DTC are stored in the ECM memory.

Procedures for clearing the DTC and the 1st trip DTC from the ECM memory are described in "How to Erase DTC and 1st Trip DTC".

For malfunctions in which 1st trip DTCs are displayed, refer to [EC-521, "DTC Index"](#). These items are required by legal regulations to continuously monitor the system/component. In addition, the items monitored non-continuously are also displayed on CONSULT-III.

1st trip DTC is specified in Service \$07 of SAE J1979. 1st trip DTC detection occurs without illuminating the MIL and therefore does not warn the driver of a malfunction. However, 1st trip DTC detection will not prevent the vehicle from being tested, for example during Inspection/Maintenance (I/M) tests.

When a 1st trip DTC is detected, check, print out or write down and erase (1st trip) DTC and Freeze Frame data as specified in Work Flow procedure Step 2, refer to [EC-8, "Work Flow"](#). Then perform DTC Confirmation Procedure or Component Function Check to try to duplicate the malfunction. If the malfunction is duplicated, the item requires repair.

Freeze Frame Data and 1st Trip Freeze Frame Data

The ECM records the driving conditions such as fuel system status, calculated load value, engine coolant temperature, short term fuel trim, long term fuel trim, engine speed, vehicle speed, absolute throttle position, base fuel schedule and intake air temperature at the moment a malfunction is detected.

Data which are stored in the ECM memory, along with the 1st trip DTC, are called 1st trip freeze frame data. The data, stored together with the DTC data, are called freeze frame data and displayed on CONSULT-III or GST. The 1st trip freeze frame data can only be displayed on the CONSULT-III screen, not on the GST.

Only one set of freeze frame data (either 1st trip freeze frame data or freeze frame data) can be stored in the ECM. 1st trip freeze frame data is stored in the ECM memory along with the 1st trip DTC. There is no priority for 1st trip freeze frame data and it is updated each time a different 1st trip DTC is detected. However, once freeze frame data (2nd trip detection/MIL on) is stored in the ECM memory, 1st trip freeze frame data is no longer stored. Remember, only one set of freeze frame data can be stored in the ECM. The ECM has the following priorities to update the data.

Priority	Items	
1	Freeze frame data	Misfire — DTC: P0300 - P0306 Fuel Injection System Function — DTC: P0171, P0172, P0174, P0175
2		Except the above items (Includes CVT related items)
3	1st trip freeze frame data	

For example, the EGR malfunction (Priority: 2) was detected and the freeze frame data was saved in the 2nd trip. After that when the misfire (Priority: 1) is detected in another trip, the freeze frame data will be updated from the EGR malfunction to the misfire. The 1st trip freeze frame data is updated each time a different malfunction is detected. There is no priority for 1st trip freeze frame data. However, once freeze frame data is stored in the ECM memory, 1st trip freeze data is no longer stored (because only one freeze frame data or 1st trip freeze frame data can be stored in the ECM). If freeze frame data is stored in the ECM memory and freeze frame data with the same priority occurs later, the first (original) freeze frame data remains unchanged in the ECM memory.

Both 1st trip freeze frame data and freeze frame data (along with the DTCs) are cleared when the ECM memory is erased. Procedures for clearing the ECM memory are described in "How to Erase DTC and 1st Trip DTC".

How to Read DTC and 1st Trip DTC

With CONSULT-III

CONSULT-III displays the DTC in "SELF DIAGNOSTIC RESULT" mode. Examples: P0340, P0850, P1148, etc.

These DTCs are prescribed by SAE J2012.

ON BOARD DIAGNOSTIC (OBD) SYSTEM

[VQ35DE]

< FUNCTION DIAGNOSIS >

(CONSULT-III also displays the malfunctioning component or system.)

Time data indicates how many times the vehicle was driven after the last detection of a DTC.

If the DTC is being detected currently, the time data will be [0].

If a 1st trip DTC is stored in the ECM, the time data will be [1t].

With GST

GST (Generic Scan Tool) displays the DTC in Diagnostic Service \$03. Examples: P0340, P0850, P1148, etc. These DTCs are prescribed by SAE J2012.

1st trip DTC is displayed in Diagnostic Service \$07.

No Tools

The number of blinks of the MIL in the Diagnostic Test Mode II (Self-Diagnostic Results) indicates the DTC. Example: 0340, 0850, 1148, etc.

These DTCs are controlled by NISSAN.

- **1st trip DTC No. is the same as DTC No.**
- **Output of a DTC indicates a malfunction. However, GST and the Diagnostic Test Mode II do not indicate whether the malfunction is still occurring or has occurred in the past and has returned to normal. CONSULT-III can identify malfunction status as shown below. Therefore, using CONSULT-III (if available) is recommended.**

How to Erase DTC and 1st Trip DTC

With CONSULT-III

NOTE:

- If the ignition switch stays ON after repair work, be sure to turn ignition switch OFF once. Wait at least 10 seconds and then turn it ON (engine stopped) again.
 - If the DTC is not for CVT related items (see [EC-521](#)), skip step 1.
1. Erase DTC in TCM. Refer to [TM-32, "Diagnosis Description"](#).
 2. Select "ENGINE" with CONSULT-III.
 3. Select "SELF-DIAG RESULTS".
 4. Touch "ERASE". (DTC in ECM will be erased.)

WITH GST

NOTE:

- If the ignition switch stays ON after repair work, be sure to turn ignition switch OFF once. Wait at least 10 seconds and then turn it ON (engine stopped) again.
- Select Service \$04 with GST (Generic Scan Tool).

No Tools

NOTE:

- If the ignition switch stays ON after repair work, be sure to turn ignition switch OFF once. Wait at least 10 seconds and then turn it ON (engine stopped) again.

Erase DTC in ECM. Refer to How to Erase Diagnostic Test Mode II (Self-diagnostic Results).

- **If the battery is disconnected, the emission-related diagnostic information will be cleared within 24 hours.**
- **The following data are cleared when the ECM memory is erased.**
 - Diagnostic trouble codes
 - 1st trip diagnostic trouble codes
 - Freeze frame data
 - 1st trip freeze frame data
 - System readiness test (SRT) codes
 - Test values

Actual work procedures are explained using a DTC as an example. Be careful so that not only the DTC, but all of the data listed above, are cleared from the ECM memory during work procedures.

SYSTEM READINESS TEST (SRT) CODE

System Readiness Test (SRT) code is specified in Service \$01 of SAE J1979.

As part of an enhanced emissions test for Inspection & Maintenance (I/M), certain states require the status of SRT be used to indicate whether the ECM has completed self-diagnosis of major emission systems and components. Completion must be verified in order for the emissions inspection to proceed.

If a vehicle is rejected for a State emissions inspection due to one or more SRT items indicating "INCMP", use the information in this Service Manual to set the SRT to "CMPLT".

In most cases the ECM will automatically complete its self-diagnosis cycle during normal usage, and the SRT status will indicate "CMPLT" for each application system. Once set as "CMPLT", the SRT status remains "CMPLT" until the self-diagnosis memory is erased.

ON BOARD DIAGNOSTIC (OBD) SYSTEM

< FUNCTION DIAGNOSIS >

[VQ35DE]

Occasionally, certain portions of the self-diagnostic test may not be completed as a result of the customer's normal driving pattern; the SRT will indicate "INCMP" for these items.

NOTE:

The SRT will also indicate "INCMP" if the self-diagnosis memory is erased for any reason or if the ECM memory power supply is interrupted for several hours.

If, during the state emissions inspection, the SRT indicates "CMPLT" for all test items, the inspector will continue with the emissions test. However, if the SRT indicates "INCMP" for one or more of the SRT items the vehicle is returned to the customer untested.

NOTE:

If MIL is ON during the state emissions inspection, the vehicle is also returned to the customer untested even though the SRT indicates "CMPLT" for all test items. Therefore, it is important to check SRT ("CMPLT") and DTC (No DTCs) before the inspection.

SRT Item

The table below shows required self-diagnostic items to set the SRT to "CMPLT".

SRT item (CONSULT-III indication)	Performance Priority*	Required self-diagnostic items to set the SRT to "CMPLT"	Corresponding DTC No.
CATALYST	2	Three way catalyst function	P0420, P0430
EVAP SYSTEM	2	EVAP control system purge flow monitoring	P0441
	1	EVAP control system	P0442
	2	EVAP control system	P0456
HO2S	2	Air fuel ratio (A/F) sensor 1	P0133, P0153
		Heated oxygen sensor 2	P0137, P0157
		Heated oxygen sensor 2	P0138, P0158
		Heated oxygen sensor 2	P0139, P0159

*: If completion of several SRTs is required, perform driving patterns (DTC confirmation procedure), one by one based on the priority for models with CONSULT-III.

SRT Set Timing

SRT is set as "CMPLT" after self-diagnosis has been performed one or more times. Completion of SRT is done regardless of whether the result is OK or NG. The set timing is different between OK and NG results and is shown in the table below.

Self-diagnosis result		Example				
		Diagnosis	Ignition cycle			
			← ON → OFF	← ON → OFF	← ON → OFF	← ON →
All OK	Case 1	P0400	OK (1)	— (1)	OK (2)	— (2)
		P0402	OK (1)	— (1)	— (1)	OK (2)
		P1402	OK (1)	OK (2)	— (2)	— (2)
		SRT of EGR	"CMPLT"	"CMPLT"	"CMPLT"	"CMPLT"
	Case 2	P0400	OK (1)	— (1)	— (1)	— (1)
		P0402	— (0)	— (0)	OK (1)	— (1)
		P1402	OK (1)	OK (2)	— (2)	— (2)
		SRT of EGR	"INCMP"	"INCMP"	"CMPLT"	"CMPLT"
NG exists	Case 3	P0400	OK	OK	—	—
		P0402	—	—	—	—
		P1402	NG	—	NG	NG (Consecutive NG)
		(1st trip) DTC	1st trip DTC	—	1st trip DTC	DTC (= MIL ON)
		SRT of EGR	"INCMP"	"INCMP"	"INCMP"	"CMPLT"

OK: Self-diagnosis is carried out and the result is OK.

ON BOARD DIAGNOSTIC (OBD) SYSTEM

[VQ35DE]

< FUNCTION DIAGNOSIS >

NG: Self-diagnosis is carried out and the result is NG.

—: Self-diagnosis is not carried out.

When all SRT related self-diagnoses show OK results in a single cycle (Ignition OFF-ON-OFF), the SRT will indicate "CMPLT". → Case 1 above

When all SRT related self-diagnoses show OK results through several different cycles, the SRT will indicate "CMPLT" at the time the respective self-diagnoses have at least one OK result. → Case 2 above

If one or more SRT related self-diagnoses show NG results in 2 consecutive cycles, the SRT will also indicate "CMPLT". → Case 3 above

The table above shows that the minimum number of cycles for setting SRT as "INCMP" is the number one (1) for each self-diagnosis (Case 1 & 2) or the number two (2) for one of self-diagnoses (Case 3). However, in preparation for the state emissions inspection, it is unnecessary for each self-diagnosis to be executed twice (Case 3) for the following reasons:

- The SRT will indicate "CMPLT" at the time the respective self-diagnoses have one (1) OK result.
- The emissions inspection requires "CMPLT" of the SRT only with OK self-diagnosis results.
- During SRT driving pattern, the 1st trip DTC (NG) is detected prior to "CMPLT" of SRT and the self-diagnosis memory must be erased from the ECM after repair.
- If the 1st trip DTC is erased, all the SRT will indicate "INCMP".

NOTE:

SRT can be set as "CMPLT" together with the DTC(s). Therefore, DTC check must always be carried out prior to the state emission inspection even though the SRT indicates "CMPLT".

SRT Service Procedure

If a vehicle has failed the state emissions inspection due to one or more SRT items indicating "INCMP", review the flowchart diagnostic sequence on the next page.

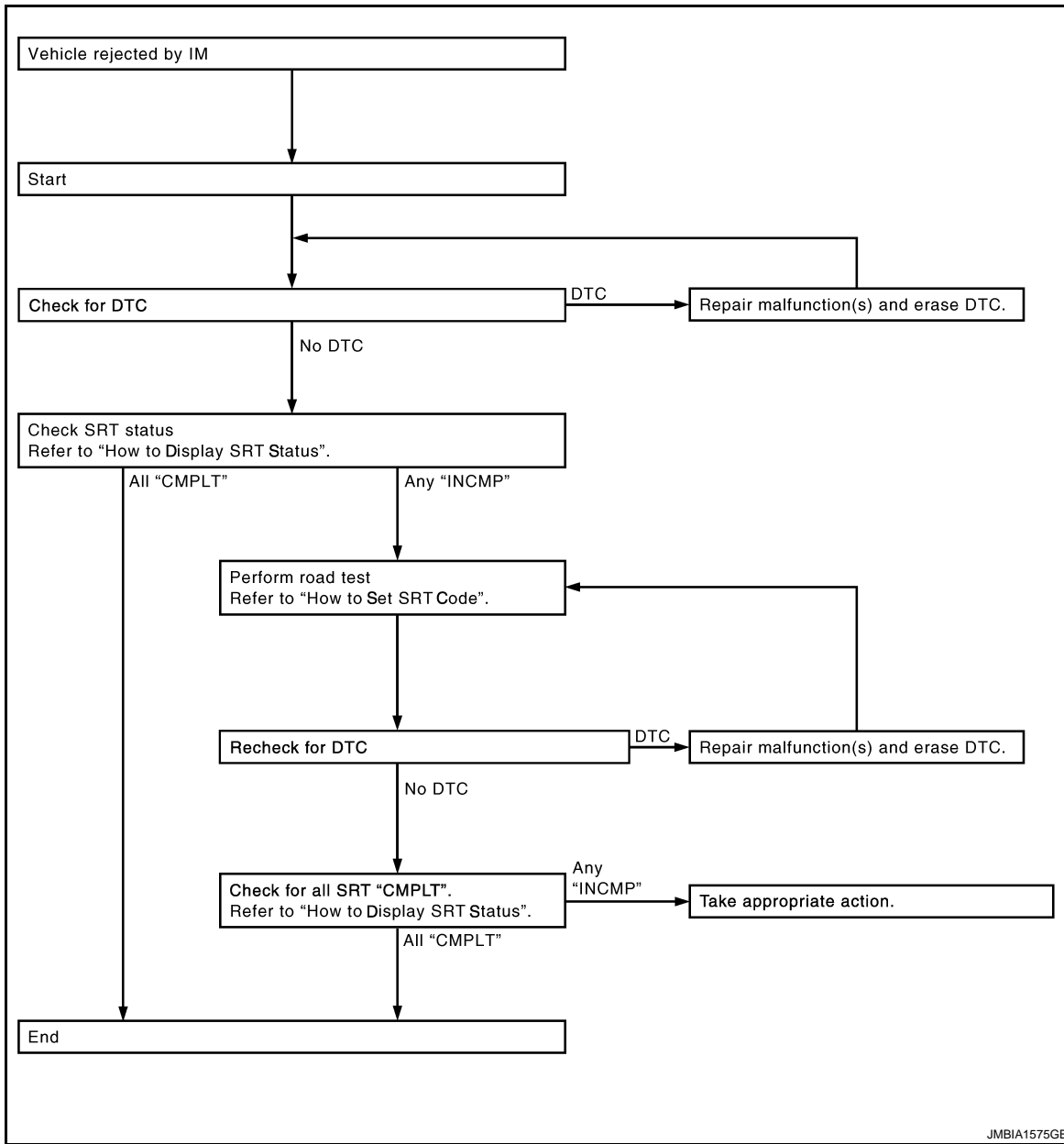

How to Display SRT Status

WITH CONSULT-III

Selecting "SRT STATUS" in "DTC CONFIRMATION" mode with CONSULT-III.

For items whose SRT codes are set, "CMPLT" is displayed on the CONSULT-III screen; for items whose SRT codes are not set, "INCMP" is displayed.

NOTE:

Though displayed on the CONSULT-III screen, "HO2S HTR" is not SRT item.

WITH GST

Selecting Service \$01 with GST (Generic Scan Tool)

NO TOOLS

A SRT code itself cannot be displayed, however SRT status can.

1. Turn ignition switch ON and wait 20 seconds.
2. SRT status is indicated as shown below.
 - When all SRT codes are set, MIL illuminates continuously.

ON BOARD DIAGNOSTIC (OBD) SYSTEM

[VQ35DE]

< FUNCTION DIAGNOSIS >

- When any SRT codes are not set, MIL will blink periodically for 10 seconds.

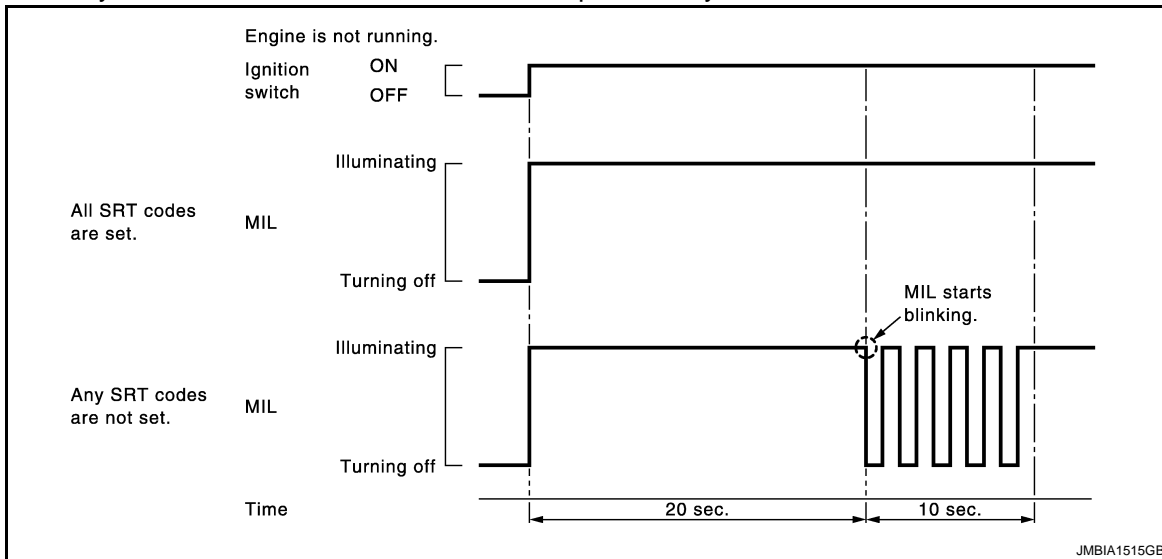

MALFUNCTION INDICATOR LAMP (MIL)

Description

The MIL is located on the instrument panel.

- The MIL will illuminate when the ignition switch is turned ON without the engine running. This is a bulb check. If the MIL does not illuminate, check MIL circuit. Refer to [EC-456. "Component Function Check"](#).
- When the engine is started, the MIL should turn off. If the MIL remains on, the on board diagnostic system has detected an engine system malfunction.

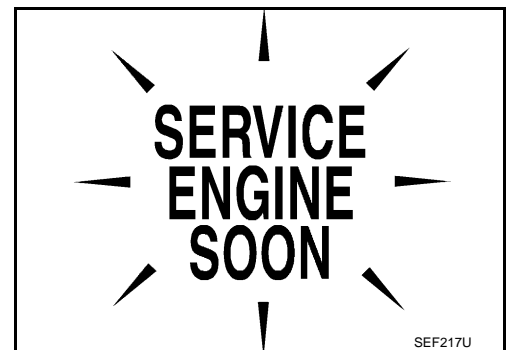







On Board Diagnostic System Function

The on board diagnostic system has the following three functions.

ON BOARD DIAGNOSTIC (OBD) SYSTEM

< FUNCTION DIAGNOSIS >

[VQ35DE]

Diagnostic Test Mode	KEY and ENG. Status	Function	Explanation of Function
Mode I	Ignition switch in ON position 	BULB CHECK	This function checks the MIL bulb for damage (blown, open circuit, etc.). If the MIL does not illuminate, check MIL circuit.
	Engine stopped 		
Mode II	Engine running 	MALFUNCTION WARNING	When a malfunction is detected twice in two consecutive driving cycles (two trip detection logic), the MIL will illuminate to inform the driver that a malfunction has been detected. The following malfunctions will illuminate or blink the MIL in the 1st trip. • Misfire (Possible three way catalyst damage) • One trip detection diagnoses
	Ignition switch in ON position 		
Mode I	Engine stopped 	SELF-DIAGNOSTIC RESULTS	This function allows DTCs and 1st trip DTCs to be read.
	Ignition switch in ON position 		

Diagnostic Test Mode I — Bulb Check

In this mode, the MIL on the instrument panel should stay ON. If it remains OFF, check MIL circuit. Refer to [EC-456, "Component Function Check"](#).

Diagnostic Test Mode I — Malfunction Warning

MIL	Condition
ON	When the malfunction is detected.
OFF	No malfunction.

This DTC number is clarified in Diagnostic Test Mode II (SELF-DIAGNOSTIC RESULTS)

Diagnostic Test Mode II — Self-diagnostic Results

In this mode, the DTC and 1st trip DTC are indicated by the number of blinks of the MIL as shown below. The DTC and 1st trip DTC are displayed at the same time. If the MIL does not illuminate in diagnostic test mode I (Malfunction warning), all displayed items are 1st trip DTCs. If only one code is displayed when the MIL illuminates in diagnostic test mode II (SELF-DIAGNOSTIC RESULTS), it is a DTC; if two or more codes are displayed, they may be either DTCs or 1st trip DTCs. DTC No. is same as that of 1st trip DTC. These uniden-

ON BOARD DIAGNOSTIC (OBD) SYSTEM

[VQ35DE]

< FUNCTION DIAGNOSIS >

tified codes can be identified by using the CONSULT-III or GST. A DTC will be used as an example for how to read a code.

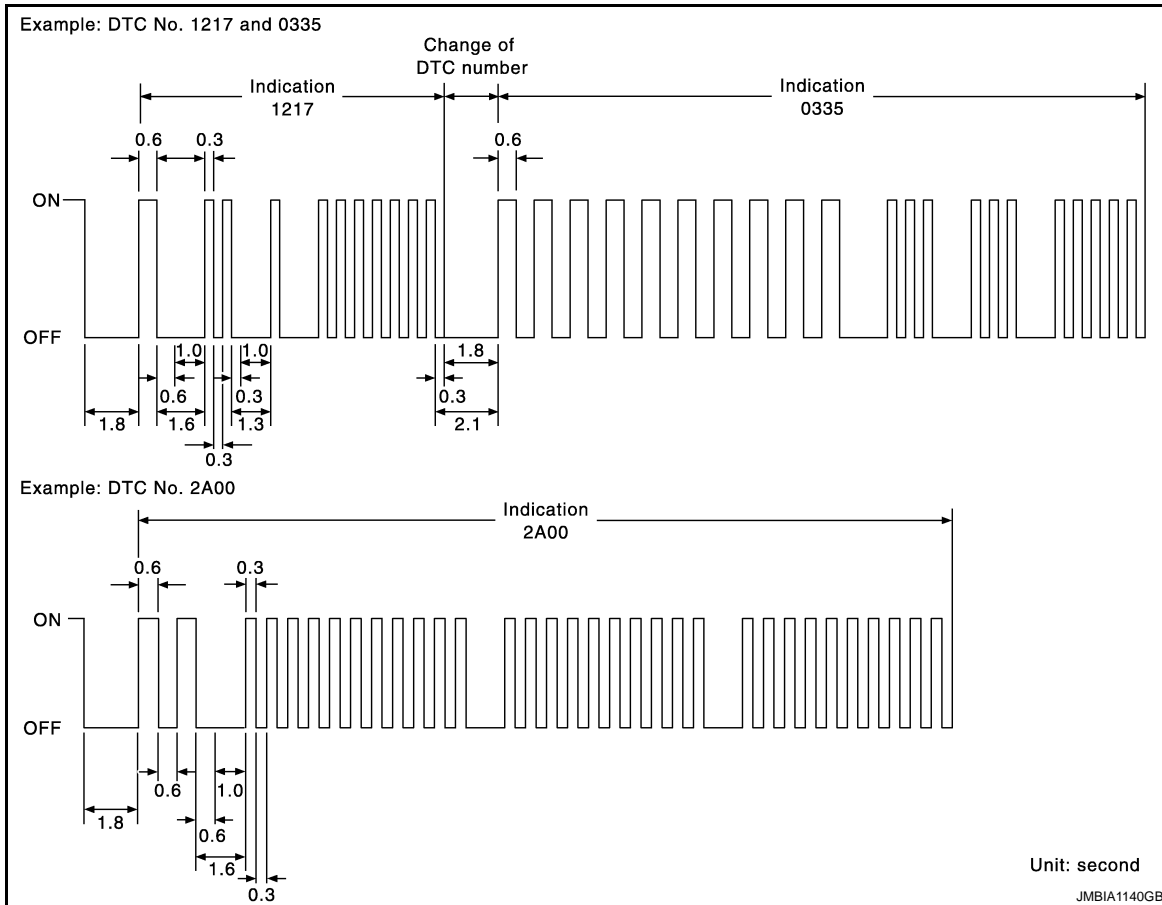

A particular trouble code can be identified by the number of four-digit numeral blinks as per the following.

Number	0	1	2	3	4	5	6	7	8	9	A	B	C	D	E	F
Blinks	10	1	2	3	4	5	6	7	8	9	11	12	13	14	15	16

The length of time the 1,000th-digit numeral flashes on and off is 1.2 seconds consisting of an ON (0.6-seconds) - OFF (0.6-seconds) cycle.

The 100th-digit numeral and lower digit numerals consist of a 0.3-seconds ON and 0.3-seconds OFF cycle.

A change from one digit numeral to another occurs at an interval of 1.0-second OFF. In other words, the later numeral appears on the display 1.3 seconds after the former numeral has disappeared.

A change from one trouble code to another occurs at an interval of 1.8-seconds OFF.

In this way, all the detected malfunctions are classified by their DTC numbers. The DTC 0000 refers to no malfunction. (See [EC-521, "DTC Index"](#))

How to Switch Diagnostic Test Mode

NOTE:

- It is better to count the time accurately with a clock.
- It is impossible to switch the diagnostic mode when an accelerator pedal position sensor circuit has a malfunction.
- ECM always returns to Diagnostic Test Mode I after the ignition switch is turned OFF.

HOW TO SET DIAGNOSTIC TEST MODE II (SELF-DIAGNOSTIC RESULTS)

1. Confirm that accelerator pedal is fully released, turn ignition switch ON and wait 3 seconds.
2. Repeat the following procedure quickly 5 times within 5 seconds.
 - Fully depress the accelerator pedal.
 - Fully release the accelerator pedal.
3. Wait 7 seconds, fully depress the accelerator pedal and keep it depressed for approx. 10 seconds until the MIL starts blinking.
4. Fully release the accelerator pedal.
ECM has entered to Diagnostic Test Mode II (Self-diagnostic results).

NOTE:

ON BOARD DIAGNOSTIC (OBD) SYSTEM

< FUNCTION DIAGNOSIS >

[VQ35DE]

Wait until the same DTC (or 1st trip DTC) appears to completely confirm all DTCs.

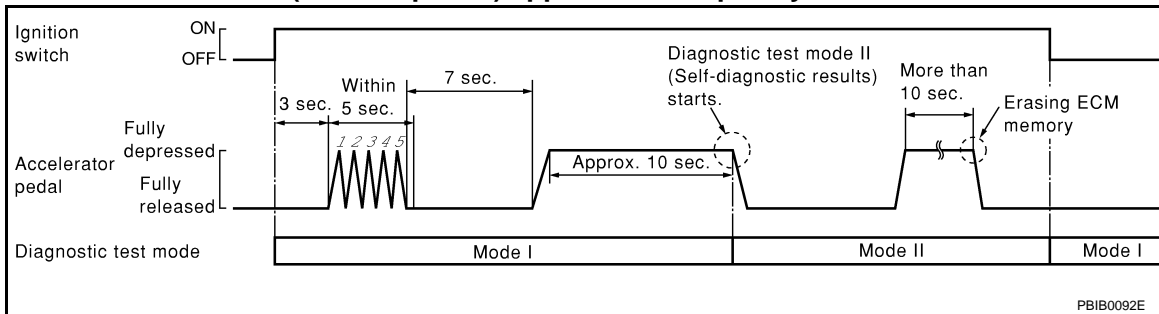

HOW TO ERASE DIAGNOSTIC TEST MODE II (SELF-DIAGNOSTIC RESULTS)

1. Set ECM in Diagnostic Test Mode II (Self-diagnostic results). Refer to "How to Set Diagnostic Test Mode II (Self-diagnostic Results)".
2. Fully depress the accelerator pedal and keep it depressed for more than 10 seconds.
The emission-related diagnostic information has been erased from the backup memory in the ECM.
3. Fully release the accelerator pedal, and confirm the DTC 0000 is displayed.
 - If the battery is disconnected, the DTC will be lost from the backup memory within 24 hours.
 - Do not erase the stored memory before starting trouble diagnoses.

OBD System Operation Chart

Relationship Between MIL, 1st Trip DTC, DTC, and Detectable Items

- When a malfunction is detected for the 1st time, the 1st trip DTC and the 1st trip freeze frame data are stored in the ECM memory.
- When the same malfunction is detected in two consecutive trips, the DTC and the freeze frame data are stored in the ECM memory, and the MIL will come on.
- The MIL will turn off after the vehicle is driven 3 times (driving pattern B) with no malfunction. A drive is counted only when the recorded driving pattern is met (as stored in the ECM). If another malfunction occurs while counting, the counter will reset.
- The DTC and the freeze frame data will be stored until the vehicle is driven 40 times (driving pattern A) without the same malfunction recurring (except for Misfire and Fuel Injection System). For Misfire and Fuel Injection System, the DTC and freeze frame data will be stored until the vehicle is driven 80 times (driving pattern C) without the same malfunction recurring. The "TIME" in "SELF-DIAGNOSTIC RESULTS" mode of CONSULT-III will count the number of times the vehicle is driven.
- The 1st trip DTC is not displayed when the self-diagnosis results in OK for the 2nd trip.

Summary Chart

Items	Fuel Injection System	Misfire	Other
MIL (turns off)	3 (pattern B)	3 (pattern B)	3 (pattern B)
DTC, Freeze Frame Data (no display)	80 (pattern C)	80 (pattern C)	40 (pattern A)
1st Trip DTC (clear)	1 (pattern C), *1	1 (pattern C), *1	1 (pattern B)
1st Trip Freeze Frame Data (clear)	*1, *2	*1, *2	1 (pattern B)

For details about patterns B and C under "Fuel Injection System" and "Misfire", see "EXPLANATION FOR DRIVING PATTERNS FOR "MISFIRE <EXHAUST QUALITY DETERIORATION>", "FUEL INJECTION SYSTEM".

For details about patterns A and B under Other, see "EXPLANATION FOR DRIVING PATTERNS FOR "MISFIRE <EXHAUST QUALITY DETERIORATION>", "FUEL INJECTION SYSTEM".

*1: Clear timing is at the moment OK is detected.

*2: Clear timing is when the same malfunction is detected in the 2nd trip.

Relationship Between MIL, DTC, 1st Trip DTC and Driving Patterns for "Misfire <Exhaust Quality Deterioration>", "Fuel Injection System"

ON BOARD DIAGNOSTIC (OBD) SYSTEM

< FUNCTION DIAGNOSIS >

[VQ35DE]

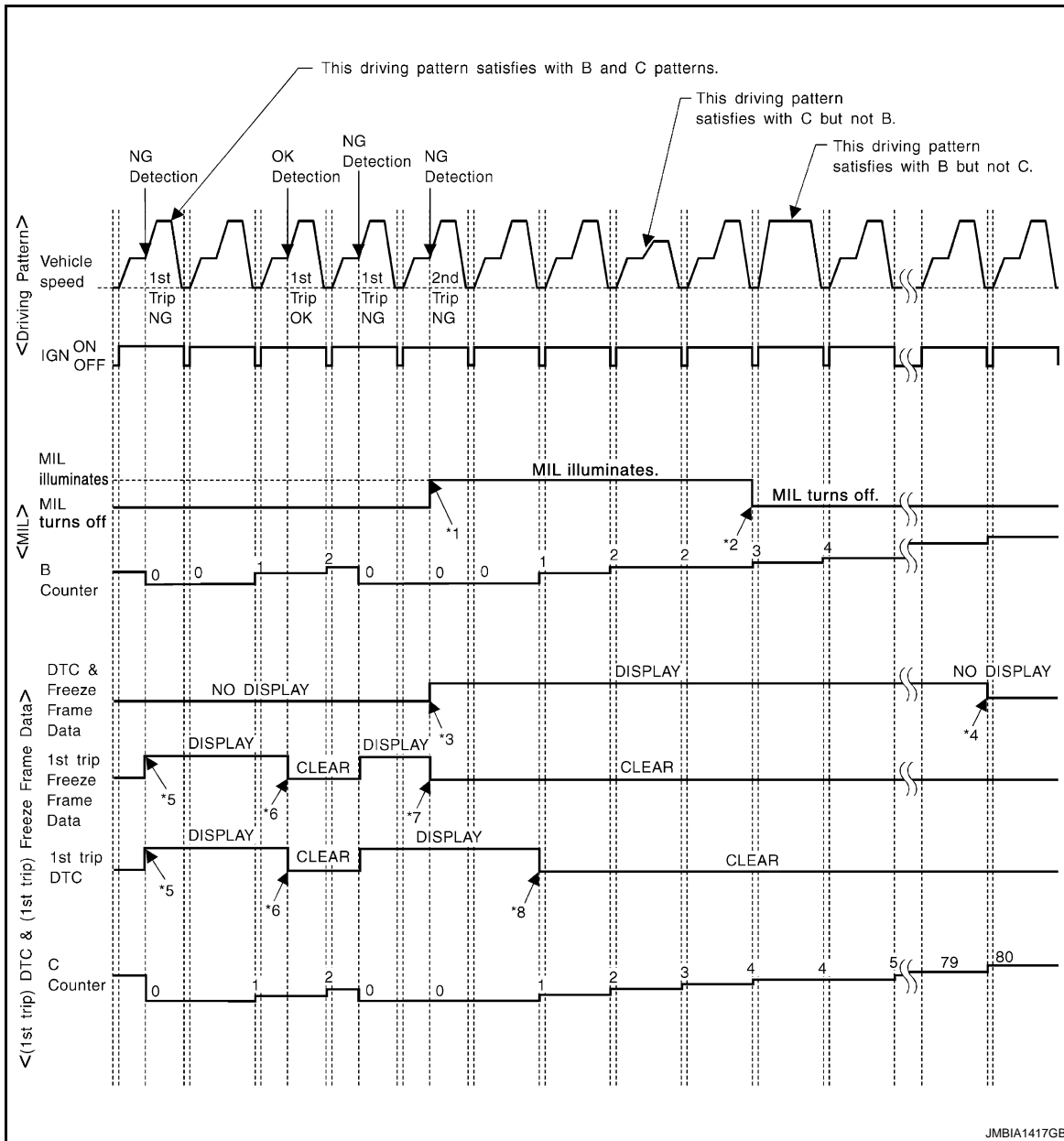

- *1: When the same malfunction is detected in two consecutive trips, MIL will illuminate.
- *2: MIL will turn off after vehicle is driven 3 times (pattern B) without any malfunctions.
- *3: When the same malfunction is detected in two consecutive trips, the DTC and the freeze frame data will be stored in ECM.
- *4: The DTC and the freeze frame data will not be displayed any longer after vehicle is driven 80 times (pattern C) without the same malfunction. (The DTC and the freeze frame data still remain in ECM.)
- *5: When a malfunction is detected for the 1st time, the 1st trip DTC and the 1st trip freeze frame data will be stored in ECM.
- *6: The 1st trip DTC and the 1st trip freeze frame data will be cleared at the moment OK is detected.
- *7: When the same malfunction is detected in the 2nd trip, the 1st trip freeze frame data will be cleared.
- *8: 1st trip DTC will be cleared when vehicle is driven once (pattern C) without the same malfunction after DTC is stored in ECM.

Explanation for Driving Patterns for "Misfire <Exhaust Quality Deterioration>", "Fuel Injection System"

<Driving Pattern B>

Driving pattern B means the vehicle operation as per the following:

All components and systems should be monitored at least once by the OBD system.

ON BOARD DIAGNOSTIC (OBD) SYSTEM

[VQ35DE]

< FUNCTION DIAGNOSIS >

- The B counter will be cleared when the malfunction is detected once regardless of the driving pattern.
- The B counter will be counted up when driving pattern B is satisfied without any malfunction.
- The MIL will turn off when the B counter reaches 3. (*2 in "OBD SYSTEM OPERATION CHART")

<Driving Pattern C>

Driving pattern C means operating vehicle as per the following:

The following conditions should be satisfied at the same time:

Engine speed: (Engine speed in the freeze frame data) \pm 375 rpm

Calculated load value: (Calculated load value in the freeze frame data) \times (1 \pm 0.1) [%]

Engine coolant temperature (T) condition:

- When the freeze frame data shows lower than 70°C (158°F), T should be lower than 70°C (158°F).
- When the freeze frame data shows higher than or equal to 70°C (158°F), T should be higher than or equal to 70°C (158°F).

Example:

If the stored freeze frame data is as per the following:

Engine speed: 850 rpm, Calculated load value: 30%, Engine coolant temperature: 80°C (176°F)

To be satisfied with driving pattern C, the vehicle should run under the following conditions:

Engine speed: 475 - 1,225 rpm, Calculated load value: 27 - 33%, Engine coolant temperature: more than 70°C (158°F)

- The C counter will be cleared when the malfunction is detected regardless of vehicle conditions above.
- The C counter will be counted up when vehicle conditions above are satisfied without the same malfunction.
- The DTC will not be displayed after C counter reaches 80.
- The 1st trip DTC will be cleared when C counter is counted once without the same malfunction after DTC is stored in ECM.

Relationship Between MIL, DTC, 1st Trip DTC and Driving Patterns Except For "Misfire <Exhaust Quality Deterioration>", "Fuel Injection System"

A

EC

C

D

E

F

G

H

I

J

K

L

M

N

O

P

ON BOARD DIAGNOSTIC (OBD) SYSTEM

< FUNCTION DIAGNOSIS >

[VQ35DE]

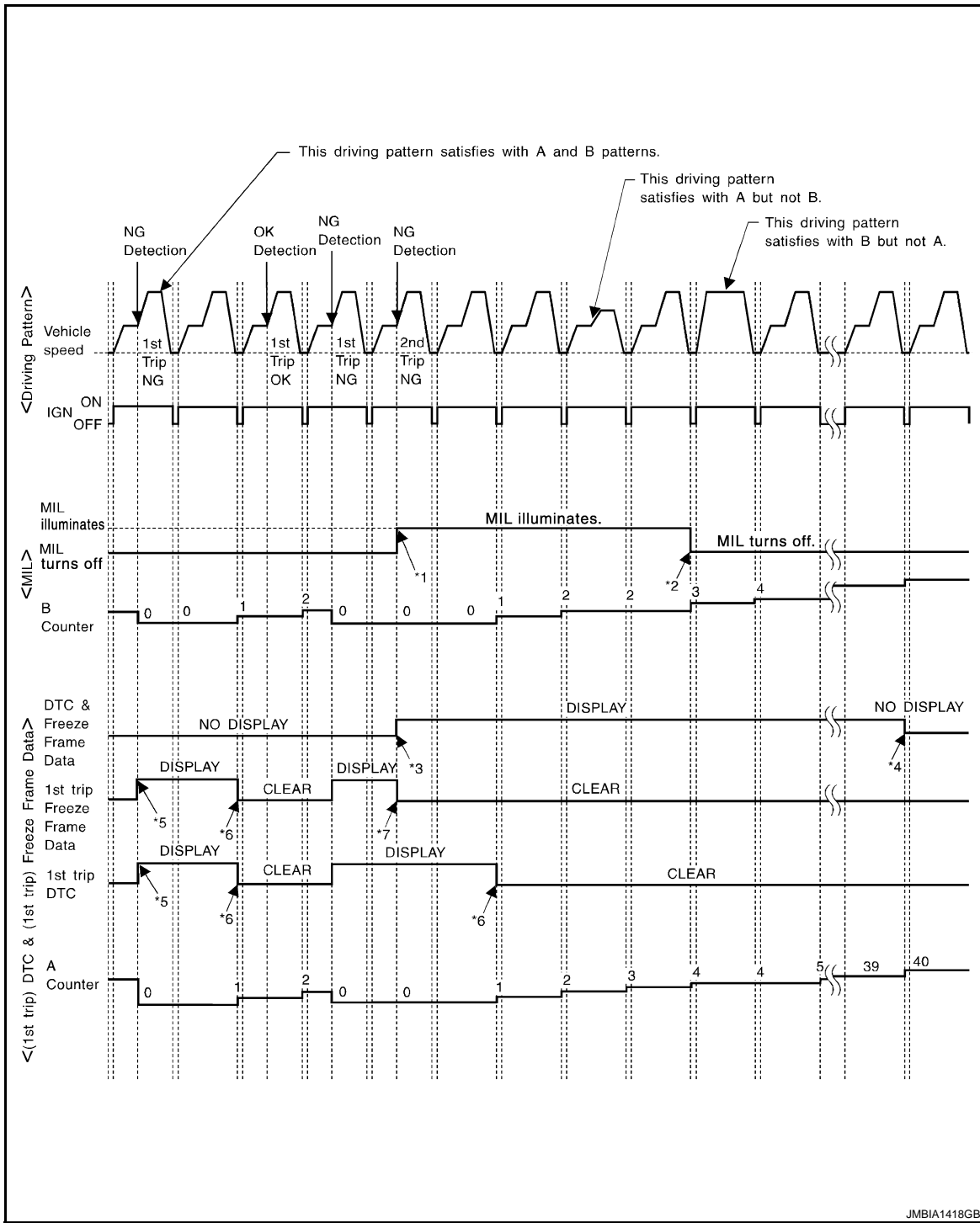

*1: When the same malfunction is detected in two consecutive trips, MIL will illuminate.

*2: MIL will turn off after vehicle is driven 3 times (pattern B) without any malfunctions.

*3: When the same malfunction is detected in two consecutive trips, the DTC and the freeze frame data will be stored in ECM.

ON BOARD DIAGNOSTIC (OBD) SYSTEM

[VQ35DE]

< FUNCTION DIAGNOSIS >

*4: The DTC and the freeze frame data will not be displayed any longer after vehicle is driven 40 times (pattern A) without the same malfunction. (The DTC and the freeze frame data still remain in ECM.)

*5: When a malfunction is detected for the 1st time, the 1st trip DTC and the 1st trip freeze frame data will be stored in ECM.

*6: 1st trip DTC will be cleared after vehicle is driven once (pattern B) without the same malfunction.

*7: When the same malfunction is detected in the 2nd trip, the 1st trip freeze frame data will be cleared.

Explanation for Driving Patterns Except for "Misfire <Exhaust Quality Deterioration>", "Fuel Injection System" <Driving Pattern A>

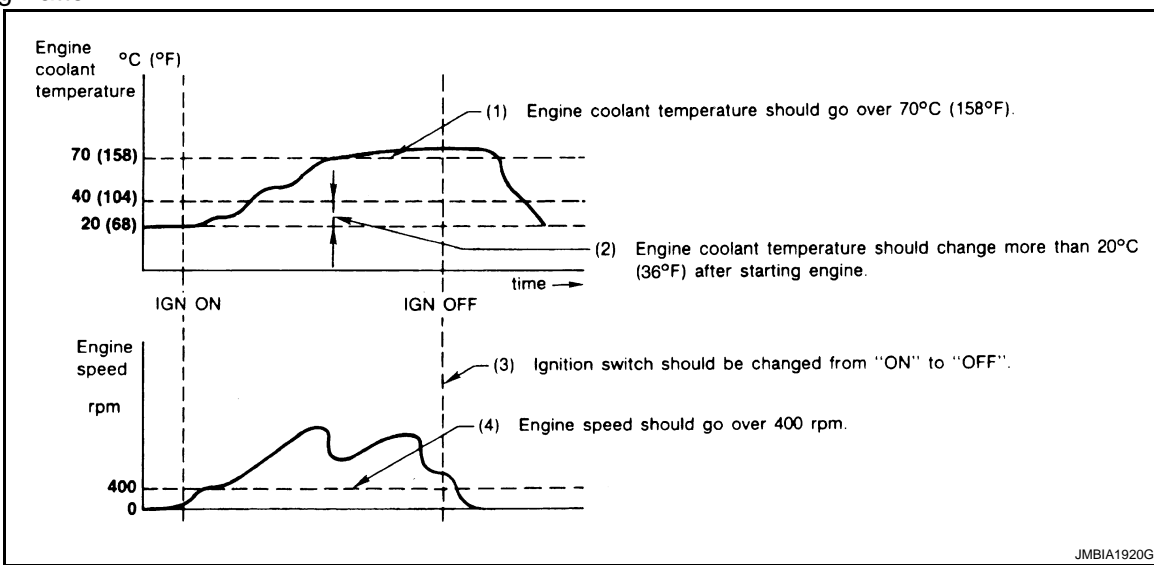

- The A counter will be cleared when the malfunction is detected regardless of (1) - (4).
- The A counter will be counted up when (1) - (4) are satisfied without the same malfunction.
- The DTC will not be displayed after the A counter reaches 40.

<Driving Pattern B>

Driving pattern B means operating vehicle as per the following:

All components and systems should be monitored at least once by the OBD system.

- The B counter will be cleared when the malfunction is detected once regardless of the driving pattern.
- The B counter will be counted up when driving pattern B is satisfied without any malfunctions.
- The MIL will turn off when the B counter reaches 3 (*2 in OBD SYSTEM OPERATION CHART).

CONSULT-III Function

INFOID:000000003387927

FUNCTION

Diagnostic test mode	Function
Work Support	This mode enables a technician to adjust some devices faster and more accurately by following the indications on the CONSULT-III unit.
Self Diagnostic Result	Self-diagnostic results such as 1st trip DTC, DTCs and 1st trip freeze frame data or freeze frame data can be read and erased quickly.*
Data Monitor	Input/Output data in the ECM can be read.
Active Test	Diagnostic Test Mode in which CONSULT-III drives some actuators apart from the ECM and also shifts some parameters in a specified range.
DTC & SRT Confirmation	The status of system monitoring tests and the self-diagnosis status/results can be confirmed.
Function Test	This mode is used to inform customers when the vehicle requires periodic maintenance.
ECU Part Number	ECM part number can be read.

*: The following emission-related diagnostic information is cleared when the ECM memory is erased.

- Diagnostic trouble codes
- 1st trip diagnostic trouble codes
- Freeze frame data

ON BOARD DIAGNOSTIC (OBD) SYSTEM

[VQ35DE]

< FUNCTION DIAGNOSIS >

- 1st trip freeze frame data
- System readiness test (SRT) codes
- Test values

ENGINE CONTROL COMPONENT PARTS/CONTROL SYSTEMS APPLICATION

Item		DIAGNOSTIC TEST MODE						
		WORK SUPPORT	SELF-DIAGNOSTIC RESULTS		DATA MONITOR	ACTIVE TEST	DTC & SRT CONFIRMATION	
			DTC*1	FREEZE FRAME DATA*2			SRT STATUS	DTC WORK SUPPORT
ENGINE CONTROL COMPONENT PARTS INPUT	Crankshaft position sensor (POS)		×	×	×			
	Camshaft position sensor (PHASE)		×	×	×			
	Mass air flow sensor		×		×			
	Engine coolant temperature sensor		×	×	×	×		
	Engine oil temperature sensor		×		×			
	Air fuel ratio (A/F) sensor 1		×		×		×	
	Heated oxygen sensor 2		×		×		×	
	Vehicle speed signal		×	×	×			
	Accelerator pedal position sensor		×		×			
	Throttle position sensor		×	×	×			
	Fuel tank temperature sensor		×		×	×		
	EVAP control system pressure sensor		×		×			
	Intake air temperature sensor		×	×	×			
	Knock sensor		×					
	Refrigerant pressure sensor				×			
	Closed throttle position switch (accelerator pedal position sensor signal)				×			
	Air conditioner switch				×			
	Park/neutral position (PNP) signal		×		×			
	Stop lamp switch		×		×			
	Power steering pressure sensor		×		×			
	Battery voltage				×			
	Load signal				×			
	Primary speed sensor		×		×			
Fuel level sensor		×		×				
Battery current sensor		×		×				
ASCD steering switch		×		×				
ASCD brake switch		×		×				

ON BOARD DIAGNOSTIC (OBD) SYSTEM

< FUNCTION DIAGNOSIS >

[VQ35DE]

Item		DIAGNOSTIC TEST MODE						
		WORK SUPPORT	SELF-DIAGNOSTIC RESULTS		DATA MONITOR	ACTIVE TEST	DTC & SRT CONFIRMATION	
			DTC*1	FREEZE FRAME DATA*2			SRT STATUS	DTC WORK SUPPORT
ENGINE CONTROL COMPONENT PARTS	OUTPUT	Fuel injector			×	×		
	Power transistor (Ignition timing)				×	×		
	Throttle control motor relay		×		×			
	Throttle control motor		×					
	EVAP canister purge volume control solenoid valve		×		×	×		×
	Air conditioner relay				×			
	Fuel pump relay	×			×	×		
	Cooling fan relay		×		×	×		
	Air fuel ratio (A/F) sensor 1 heater		×		×		×*3	
	Heated oxygen sensor 2 heater		×		×		×*3	
	EVAP canister vent control valve	×	×		×	×		
	Intake valve timing control solenoid valve		×		×	×		
	VIAS control solenoid valve 1		×		×	×		
	VIAS control solenoid valve 2		×		×	×		
	Electronic controlled engine mount				×	×		
	Alternator				×	×		
Calculated load value			×	×				

X: Applicable

*1: This item includes 1st trip DTCs.

*2: This mode includes 1st trip freeze frame data or freeze frame data. The items appear on CONSULT-III screen in freeze frame data mode only if a 1st trip DTC or DTC is detected. For details, refer to [EC-102. "Diagnosis Description"](#).

*3: Always "CMPLT" is displayed.

WORK SUPPORT MODE

Work Item

WORK ITEM	CONDITION	USAGE
FUEL PRESSURE RELEASE	<ul style="list-style-type: none"> FUEL PUMP WILL STOP BY TOUCHING "START" DURING IDLING. CRANK A FEW TIMES AFTER ENGINE STALLS. 	When releasing fuel pressure from fuel line
IDLE AIR VOL LEARN	<ul style="list-style-type: none"> THE IDLE AIR VOLUME THAT KEEPS THE ENGINE WITHIN THE SPECIFIED RANGE IS MEMORIZED IN ECM. 	When learning the idle air volume
SELF-LEARNING CONT	<ul style="list-style-type: none"> THE COEFFICIENT OF SELF-LEARNING CONTROL MIXTURE RATIO RETURNS TO THE ORIGINAL COEFFICIENT. 	When clearing mixture ratio self-learning value

ON BOARD DIAGNOSTIC (OBD) SYSTEM

< FUNCTION DIAGNOSIS >

[VQ35DE]

WORK ITEM	CONDITION	USAGE
EVAP SYSTEM CLOSE	<p>CLOSE THE EVAP CANISTER VENT CONTROL VALVE IN ORDER TO MAKE EVAP SYSTEM CLOSE UNDER THE FOLLOWING CONDITIONS.</p> <ul style="list-style-type: none"> • IGN SW ON • ENGINE NOT RUNNING • AMBIENT TEMPERATURE IS ABOVE 0°C (32°F). • NO VACUUM AND NO HIGH PRESSURE IN EVAP SYSTEM • FUEL TANK TEMP. IS MORE THAN 0°C (32°F). • WITHIN 10 MINUTES AFTER STARTING "EVAP SYSTEM CLOSE" • WHEN TRYING TO EXECUTE "EVAP SYSTEM CLOSE" UNDER THE CONDITION EXCEPT ABOVE, CONSULT-III WILL DISCONTINUE IT AND DISPLAY APPROPRIATE INSTRUCTION. <p>NOTE: WHEN STARTING ENGINE, CONSULT-III MAY DISPLAY "BATTERY VOLTAGE IS LOW. CHARGE BATTERY", EVEN WHEN USING A CHARGED BATTERY.</p>	When detecting EVAP vapor leakage in the EVAP system
VIN REGISTRATION	<ul style="list-style-type: none"> • IN THIS MODE, VIN IS REGISTERED IN ECM. 	When registering VIN in ECM
TARGET IDLE RPM ADJ*	<ul style="list-style-type: none"> • IDLE CONDITION 	When setting target idle speed
TARGET IGN TIM ADJ*	<ul style="list-style-type: none"> • IDLE CONDITION 	When adjusting target ignition timing

*: This function is not necessary in the usual service procedure.

SELF-DIAG RESULTS MODE

Self Diagnostic Item

Regarding items of DTC and 1st trip DTC, refer to [EC-521, "DTC Index"](#).

Freeze Frame Data and 1st Trip Freeze Frame Data

Freeze frame data item*	Description
DIAG TROUBLE CODE [PXXXX]	<ul style="list-style-type: none"> • The engine control component part/control system has a trouble code that is displayed as PXXXX. (Refer to EC-521, "DTC Index".)
FUEL SYS-B1	<ul style="list-style-type: none"> • "Fuel injection system status" at the moment a malfunction is detected is displayed. • One of the following mode is displayed. Mode2: Open loop due to detected system malfunction Mode3: Open loop due to driving conditions (power enrichment, deceleration enrichment) Mode4: Closed loop - using oxygen sensor(s) as feedback for fuel control Mode5: Open loop - has not yet satisfied condition to go to closed loop
FUEL SYS-B2	
CAL/LD VALUE [%]	<ul style="list-style-type: none"> • The calculated load value at the moment a malfunction is detected is displayed.
COOLANT TEMP [°C] or [°F]	<ul style="list-style-type: none"> • The engine coolant temperature at the moment a malfunction is detected is displayed.
L-FUEL TRM-B1 [%]	<ul style="list-style-type: none"> • "Long-term fuel trim" at the moment a malfunction is detected is displayed. • The long-term fuel trim indicates much more gradual feedback compensation to the base fuel schedule than short-term fuel trim.
L-FUEL TRM-B2 [%]	
S-FUEL TRM-B1 [%]	<ul style="list-style-type: none"> • "Short-term fuel trim" at the moment a malfunction is detected is displayed. • The short-term fuel trim indicates dynamic or instantaneous feedback compensation to the base fuel schedule.
S-FUEL TRM-B2 [%]	
ENGINE SPEED [rpm]	<ul style="list-style-type: none"> • The engine speed at the moment a malfunction is detected is displayed.
VEHICL SPEED [km/h] or [mph]	<ul style="list-style-type: none"> • The vehicle speed at the moment a malfunction is detected is displayed.
ABSOL TH-P/S [%]	<ul style="list-style-type: none"> • The throttle valve opening angle at the moment a malfunction is detected is displayed.
B/FUEL SCHDL [msec]	<ul style="list-style-type: none"> • The base fuel schedule at the moment a malfunction is detected is displayed.
INT/A TEMP SE [°C] or [°F]	<ul style="list-style-type: none"> • The intake air temperature at the moment a malfunction is detected is displayed.

ON BOARD DIAGNOSTIC (OBD) SYSTEM

< FUNCTION DIAGNOSIS >

[VQ35DE]

Freeze frame data item*	Description
INT MANI PRES [kPa]	• These items are displayed but are not applicable to this model.
COMBUST CONDITION	

*: The items are the same as those of 1st trip freeze frame data.

DATA MONITOR MODE

Monitored Item

x: Applicable

Monitored item	Unit	Description	Remarks
ENG SPEED	rpm	<ul style="list-style-type: none"> Indicates the engine speed computed from the signal of the crankshaft position sensor (POS) and camshaft position sensor (PHASE). 	<ul style="list-style-type: none"> Accuracy becomes poor if engine speed drops below the idle rpm. If the signal is interrupted while the engine is running, an abnormal value may be indicated.
MAS A/F SE-B1	V	<ul style="list-style-type: none"> The signal voltage of the mass air flow sensor is displayed. 	<ul style="list-style-type: none"> When the engine is stopped, a certain value is indicated. When engine is running, specification range is indicated in "SPEC".
B/FUEL SCHDL	msec	<ul style="list-style-type: none"> "Base fuel schedule" indicates the fuel injection pulse width programmed into ECM, prior to any learned on board correction. 	<ul style="list-style-type: none"> When engine is running, specification range is indicated in "SPEC".
A/F ALPHA-B1	%	<ul style="list-style-type: none"> The mean value of the air-fuel ratio feedback correction factor per cycle is indicated. 	<ul style="list-style-type: none"> When the engine is stopped, a certain value is indicated. This data also includes the data for the air-fuel ratio learning control. When engine is running, specification range is indicated in "SPEC".
A/F ALPHA-B2			
COOLAN TEMP/S	°C or °F	<ul style="list-style-type: none"> The engine coolant temperature (determined by the signal voltage of the engine coolant temperature sensor) is displayed. 	<ul style="list-style-type: none"> When the engine coolant temperature sensor is open or short-circuited, ECM enters fail-safe mode. The engine coolant temperature determined by the ECM is displayed.
A/F SEN1 (B1)	V	<ul style="list-style-type: none"> The A/F signal computed from the input signal of the air fuel ratio (A/F) sensor 1 is displayed. 	
A/F SEN1 (B2)			
HO2S2 (B1)	V	<ul style="list-style-type: none"> The signal voltage of the heated oxygen sensor 2 is displayed. 	
HO2S2 (B2)			
HO2S2 MNTR(B1)	RICH/LEAN	<ul style="list-style-type: none"> Display of heated oxygen sensor 2 signal: RICH: means the amount of oxygen after three way catalyst is relatively small. LEAN: means the amount of oxygen after three way catalyst is relatively large. 	<ul style="list-style-type: none"> When the engine is stopped, a certain value is indicated.
HO2S2 MNTR(B2)			
VHCL SPEED SE	km/h or mph	<ul style="list-style-type: none"> The vehicle speed computed from the vehicle speed signal sent from combination meter is displayed. 	
BATTERY VOLT	V	<ul style="list-style-type: none"> The power supply voltage of ECM is displayed. 	
ACCEL SEN 1	V	<ul style="list-style-type: none"> The accelerator pedal position sensor signal voltage is displayed. 	<ul style="list-style-type: none"> ACCEL SEN 2 signal is converted by ECM internally. Thus, it differs from ECM terminal voltage signal.
ACCEL SEN 2			
TP SEN 1-B1	V	<ul style="list-style-type: none"> The throttle position sensor signal voltage is displayed. 	<ul style="list-style-type: none"> TP SEN 2-B1 signal is converted by ECM internally. Thus, it differs from ECM terminal voltage signal.
TP SEN 2-B1			
FUEL T/TMP SE	°C or °F	<ul style="list-style-type: none"> The fuel temperature (determined by the signal voltage of the fuel tank temperature sensor) is displayed. 	

ON BOARD DIAGNOSTIC (OBD) SYSTEM

< FUNCTION DIAGNOSIS >

[VQ35DE]

Monitored item	Unit	Description	Remarks
INT/A TEMP SE	°C or °F	<ul style="list-style-type: none"> The intake air temperature (determined by the signal voltage of the intake air temperature sensor) is indicated. 	
EVAP SYS PRES	V	<ul style="list-style-type: none"> The signal voltage of EVAP control system pressure sensor is displayed. 	
FUEL LEVEL SE	V	<ul style="list-style-type: none"> The signal voltage of the fuel level sensor is displayed. 	
START SIGNAL	ON/OFF	<ul style="list-style-type: none"> Indicates start signal status [ON/OFF] computed by the ECM according to the signals of engine speed and battery voltage. 	<ul style="list-style-type: none"> After starting the engine, [OFF] is displayed regardless of the starter signal.
CLSD THL POS	ON/OFF	<ul style="list-style-type: none"> Indicates idle position [ON/OFF] computed by ECM according to the accelerator pedal position sensor signal. 	
AIR COND SIG	ON/OFF	<ul style="list-style-type: none"> Indicates [ON/OFF] condition of the air conditioner switch as determined by the air conditioner signal. 	
P/N POSI SW	ON/OFF	<ul style="list-style-type: none"> Indicates [ON/OFF] condition from the park/neutral position (PNP) signal. 	
PW/ST SIGNAL	ON/OFF	<ul style="list-style-type: none"> [ON/OFF] condition of the power steering system (determined by the signal voltage of the power steering pressure sensor) is indicated. 	
LOAD SIGNAL	ON/OFF	<ul style="list-style-type: none"> Indicates [ON/OFF] condition from the electrical load signal. ON: Rear window defogger switch is ON and/or lighting switch is in 2nd position. OFF: Both rear window defogger switch and lighting switch are OFF. 	
IGNITION SW	ON/OFF	<ul style="list-style-type: none"> Indicates [ON/OFF] condition from ignition switch signal. 	
HEATER FAN SW	ON/OFF	<ul style="list-style-type: none"> Indicates [ON/OFF] condition from the heater fan switch signal. 	
BRAKE SW	ON/OFF	<ul style="list-style-type: none"> Indicates [ON/OFF] condition from the stop lamp switch signal. 	
INJ PULSE-B1	msec	<ul style="list-style-type: none"> Indicates the actual fuel injection pulse width compensated by ECM according to the input signals. 	<ul style="list-style-type: none"> When the engine is stopped, a certain computed value is indicated.
INJ PULSE-B2			
IGN TIMING	BTDC	<ul style="list-style-type: none"> Indicates the ignition timing computed by ECM according to the input signals. 	<ul style="list-style-type: none"> When the engine is stopped, a certain value is indicated.
CAL/LD VALUE	%	<ul style="list-style-type: none"> "Calculated load value" indicates the value of the current air flow divided by peak air flow. 	
MASS AIRFLOW	g·m/s	<ul style="list-style-type: none"> Indicates the mass air flow computed by ECM according to the signal voltage of the mass air flow sensor. 	
PURG VOL C/V	%	<ul style="list-style-type: none"> Indicates the EVAP canister purge volume control solenoid valve control value computed by the ECM according to the input signals. The opening becomes larger as the value increases. 	
INT/V TIM (B1)	°CA	<ul style="list-style-type: none"> Indicates [°CA] of intake camshaft advance angle. 	
INT/V TIM (B2)			
INT/V SOL-B1	%	<ul style="list-style-type: none"> The control value of the intake valve timing control solenoid valve (determined by ECM according to the input signals) is indicated. The advance angle becomes larger as the value increases. 	
INT/V SOL-B2			

ON BOARD DIAGNOSTIC (OBD) SYSTEM

< FUNCTION DIAGNOSIS >

[VQ35DE]

Monitored item	Unit	Description	Remarks
VIAS S/V-1	ON/OFF	<ul style="list-style-type: none"> The control condition of the VIAS control solenoid valve 1 (determined by ECM according to the input signals) is indicated. ON: VIAS control solenoid valve 1 is operating. OFF: VIAS control solenoid valve 1 is not operating. 	A EC
VIAS S/V-2	ON/OFF	<ul style="list-style-type: none"> The control condition of the VIAS control solenoid valve 2 (determined by ECM according to the input signals) is indicated. ON: VIAS control solenoid valve 2 is operating. OFF: VIAS control solenoid valve 2 is not operating. 	C
AIR COND RLY	ON/OFF	<ul style="list-style-type: none"> The air conditioner relay control condition (determined by ECM according to the input signals) is indicated. 	D E
ENGINE MOUNT	IDLE/TRVL	<ul style="list-style-type: none"> The control condition of the electronic controlled engine mount (determined by ECM according to the input signals) is indicated. IDLE: Engine speed is below 950 rpm TRVL: Engine speed is above 950 rpm 	F
FUEL PUMP RLY	ON/OFF	<ul style="list-style-type: none"> Indicates the fuel pump relay control condition determined by ECM according to the input signals. 	G
VENT CONT/V	ON/OFF	<ul style="list-style-type: none"> The control condition of the EVAP canister vent control valve (determined by ECM according to the input signals) is indicated. ON: Closed OFF: Open 	H
THRTL RELAY	ON/OFF	<ul style="list-style-type: none"> Indicates the throttle control motor relay control condition determined by the ECM according to the input signals. 	I
COOLING FAN	HI/MID/LOW/OFF	<ul style="list-style-type: none"> The control condition of the cooling fan (determined by ECM according to the input signals) is indicated. HI: High speed operation MID: Middle speed operation LOW: Low speed operation OFF: Stop 	J K
HO2S2 HTR (B1)	ON/OFF	<ul style="list-style-type: none"> Indicates [ON/OFF] condition of heated oxygen sensor 2 heater determined by ECM according to the input signals. 	L
HO2S2 HTR (B2)			
I/P PULLY SPD	rpm	<ul style="list-style-type: none"> Indicates the engine speed computed from the turbine revolution sensor signal. 	M
VEHICLE SPEED	km/h or mph	<ul style="list-style-type: none"> The vehicle speed computed from the vehicle speed signal sent from TCM is displayed. 	N
IDL A/V LEARN	YET/CMPLT	<ul style="list-style-type: none"> Displays the condition of idle air volume learning YET: Idle Air Volume Learning has not been performed yet. CMPLT: Idle Air Volume Learning has already been performed successfully. 	O
ENG OIL TEMP	°C or °F	<ul style="list-style-type: none"> The engine oil temperature (determined by the signal voltage of the engine oil temperature sensor) is displayed. 	P
TRVL AFTER MIL	km or mile	<ul style="list-style-type: none"> Distance traveled while MIL is activated. 	
A/F S1 HTR(B1)	%	<ul style="list-style-type: none"> Air fuel ratio (A/F) sensor 1 heater control value computed by ECM according to the input signals. The current flow to the heater becomes larger as the value increases. 	
A/F S1 HTR(B2)			

ON BOARD DIAGNOSTIC (OBD) SYSTEM

[VQ35DE]

< FUNCTION DIAGNOSIS >

Monitored item	Unit	Description	Remarks
AC PRESS SEN	V	<ul style="list-style-type: none"> The signal voltage from the refrigerant pressure sensor is displayed. 	
VHCL SPEED SE	km/h or mph	<ul style="list-style-type: none"> The vehicle speed computed from the vehicle speed signal sent from combination meter is displayed. 	
SET VHCL SPD	km/h or mph	<ul style="list-style-type: none"> The preset vehicle speed is displayed. 	
MAIN SW	ON/OFF	<ul style="list-style-type: none"> Indicates [ON/OFF] condition from MAIN switch signal. 	
CANCEL SW	ON/OFF	<ul style="list-style-type: none"> Indicates [ON/OFF] condition from CANCEL switch signal. 	
RESUME/ACC SW	ON/OFF	<ul style="list-style-type: none"> Indicates [ON/OFF] condition from RESUME/ACCELERATE switch signal. 	
SET SW	ON/OFF	<ul style="list-style-type: none"> Indicates [ON/OFF] condition from SET/COAST switch signal. 	
BRAKE SW1	ON/OFF	<ul style="list-style-type: none"> Indicates [ON/OFF] condition from ASCD brake switch signal or ASCD clutch switch. 	
BRAKE SW2	ON/OFF	<ul style="list-style-type: none"> Indicates [ON/OFF] condition of stop lamp switch signal. 	
VHCL SPD CUT	NON/CUT	<ul style="list-style-type: none"> Indicates the vehicle cruise condition. NON: Vehicle speed is maintained at the ASCD set speed. CUT: Vehicle speed decreased to excessively low compared with the ASCD set speed, and ASCD operation is cut off. 	
LO SPEED CUT	NON/CUT	<ul style="list-style-type: none"> Indicates the vehicle cruise condition. NON: Vehicle speed is maintained at the ASCD set speed. CUT: Vehicle speed decreased to excessively low, and ASCD operation is cut off. 	
AT OD MONITOR	ON/OFF	<ul style="list-style-type: none"> Indicates [ON/OFF] condition of CVT O/D according to the input signal from the TCM. 	
AT OD CANCEL	ON/OFF	<ul style="list-style-type: none"> Indicates [ON/OFF] condition of CVT O/D cancel request signal. 	
CRUISE LAMP	ON/OFF	<ul style="list-style-type: none"> Indicates [ON/OFF] condition of CRUISE lamp determined by the ECM according to the input signals. 	
SET LAMP	ON/OFF	<ul style="list-style-type: none"> Indicates [ON/OFF] condition of SET lamp determined by the ECM according to the input signals. 	
BAT CUR SEN	mV	<ul style="list-style-type: none"> The signal voltage of battery current sensor is displayed. 	
ALT DUTY SIG	ON/OFF	<ul style="list-style-type: none"> The control condition of the power generation voltage variable control (determined by ECM according to the input signals) is indicated. ON: Power generation voltage variable control is active. OFF: Power generation voltage variable control is inactive. 	
A/F ADJ-B1	—	<ul style="list-style-type: none"> Indicates the correction of a factor stored in ECM. The factor is calculated from the difference between the target air-fuel ratio stored in ECM and the air-fuel ratio calculated from A/F sensor 1 signal. 	
A/F ADJ-B2			
ALT DUTY	%	<ul style="list-style-type: none"> Indicates the duty ratio of the power generation command value. The ratio is calculated by ECM based on the battery current sensor signal. 	

NOTE:

ON BOARD DIAGNOSTIC (OBD) SYSTEM

< FUNCTION DIAGNOSIS >

[VQ35DE]

Any monitored item that does not match the vehicle being diagnosed is deleted from the display automatically.

ACTIVE TEST MODE

Test Item

TEST ITEM	CONDITION	JUDGMENT	CHECK ITEM (REMEDY)
FUEL INJECTION	<ul style="list-style-type: none"> Engine: Return to the original non-standard condition Change the amount of fuel injection using CONSULT-III. 	If malfunctioning symptom disappears, see CHECK ITEM.	<ul style="list-style-type: none"> Harness and connectors Fuel injector Air fuel ratio (A/F) sensor 1
IGNITION TIMING	<ul style="list-style-type: none"> Engine: Return to the original non-standard condition Timing light: Set Retard the ignition timing using CONSULT-III. 	If malfunctioning symptom disappears, see CHECK ITEM.	<ul style="list-style-type: none"> Perform Idle Air Volume Learning.
POWER BALANCE	<ul style="list-style-type: none"> Engine: After warming up, idle the engine. A/C switch OFF Selector lever: P or N position Cut off each injector signal one at a time using CONSULT-III. 	Engine runs rough or stops.	<ul style="list-style-type: none"> Harness and connectors Compression Fuel injector Power transistor Spark plug Ignition coil
COOLING FAN*	<ul style="list-style-type: none"> Ignition switch: ON Turn the cooling fan "HI", "MID", "LOW" and "OFF" using CONSULT-III. 	Cooling fan moves and stops.	<ul style="list-style-type: none"> Harness and connectors Cooling fan motor IPDM E/R
ENG COOLANT TEMP	<ul style="list-style-type: none"> Engine: Return to the original non-standard condition Change the engine coolant temperature using CONSULT-III. 	If malfunctioning symptom disappears, see CHECK ITEM.	<ul style="list-style-type: none"> Harness and connectors Engine coolant temperature sensor Fuel injector
FUEL PUMP RELAY	<ul style="list-style-type: none"> Ignition switch: ON (Engine stopped) Turn the fuel pump relay "ON" and "OFF" using CONSULT-III and listen to operating sound. 	Fuel pump relay makes the operating sound.	<ul style="list-style-type: none"> Harness and connectors Fuel pump relay
VIAS S/V-1	<ul style="list-style-type: none"> Ignition switch: ON Turn solenoid valve "ON" and "OFF" using CONSULT-III and listen to operating sound. 	Solenoid valve makes the operating sound.	<ul style="list-style-type: none"> Harness and connectors Solenoid valve
VIAS S/V-2	<ul style="list-style-type: none"> Ignition switch: ON Turn solenoid valve "ON" and "OFF" using CONSULT-III and listen to operating sound. 	Solenoid valve makes the operating sound.	<ul style="list-style-type: none"> Harness and connectors Solenoid valve
ENGINE MOUNTING	<ul style="list-style-type: none"> Ignition switch: ON Turn electronic controlled engine mount "IDLE" and "TRVL" with CONSULT-III. 	Electronic controlled engine mount makes the operating sound.	<ul style="list-style-type: none"> Harness and connectors Electronic controlled engine mount
PURG VOL CONT/V	<ul style="list-style-type: none"> Engine: After warming up, run engine at 1,500 rpm. Change the EVAP canister purge volume control solenoid valve opening percent using CONSULT-III. 	Engine speed changes according to the opening percent.	<ul style="list-style-type: none"> Harness and connectors Solenoid valve
FUEL/T TEMP SEN	<ul style="list-style-type: none"> Change the fuel tank temperature using CONSULT-III. 		
VENT CONTROL/V	<ul style="list-style-type: none"> Ignition switch: ON (Engine stopped) Turn solenoid valve "ON" and "OFF" with the CONSULT-III and listen to operating sound. 	Solenoid valve makes an operating sound.	<ul style="list-style-type: none"> Harness and connectors Solenoid valve

ON BOARD DIAGNOSTIC (OBD) SYSTEM

< FUNCTION DIAGNOSIS >

[VQ35DE]

TEST ITEM	CONDITION	JUDGMENT	CHECK ITEM (REMEDY)
INT V/T ASSIGN ANGLE	<ul style="list-style-type: none"> Engine: Return to the original non-standard condition Change intake valve timing using CONSULT-III. 	If malfunctioning symptom disappears, see CHECK ITEM.	<ul style="list-style-type: none"> Harness and connectors Intake valve timing control solenoid valve
ALTERNATOR DUTY	<ul style="list-style-type: none"> Engine: Idle Change duty ratio using CONSULT-III. 	Battery voltage changes.	<ul style="list-style-type: none"> Harness and connectors IPDM E/R Alternator

*: Leaving cooling fan OFF with CONSULT-III while engine is running may cause the engine to overheat.

DTC & SRT CONFIRMATION MODE

SRT STATUS Mode

For details, refer to [EC-102, "Diagnosis Description"](#).

SRT WORK SUPPORT Mode

This mode enables a technician to drive a vehicle to set the SRT while monitoring the SRT status.

DTC WORK SUPPORT Mode

Test mode	Test item	Corresponding DTC No.	Reference page
EVAPORATIVE SYSTEM	EVP SML LEAK P0442/P1442*	P0442	EC-278
		P0455	EC-314
	EVP V/S LEAK P0456/P1456*	P0456	EC-320
	PURG VOL CN/V P1444	P0443	EC-284
	PURG FLOW P0441	P0441	EC-273
A/F SEN1	A/F SEN1(B1) P1278/P1279	P0133	EC-198
	A/F SEN1(B1) P1276	P0130	EC-186
	A/F SEN1(B2) P1288/P1289	P0153	EC-198
	A/F SEN1(B2) P1286	P0150	EC-186
HO2S2	HO2S2(B1) P1146	P0138	EC-210
	HO2S2(B1) P1147	P0137	EC-203
	HO2S2(B1) P0139	P0139	EC-219
	HO2S2(B2) P1166	P0158	EC-210
	HO2S2(B2) P1167	P0157	EC-203
	HO2S2(B2) P0159	P0159	EC-219

*: DTC P1442 and P1456 does not apply to this model but appears in DTC Work Support Mode screens.

Diagnosis Tool Function

INFOID:000000003387928

DESCRIPTION

Generic Scan Tool (OBD II scan tool) complying with SAE J1978 has several functions explained below. ISO15765-4 is used as the protocol. The name "GST" or "Generic Scan Tool" is used in this service manual.

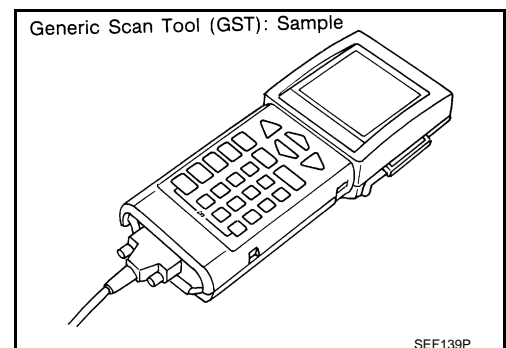

FUNCTION

ON BOARD DIAGNOSTIC (OBD) SYSTEM

< FUNCTION DIAGNOSIS >

[VQ35DE]

Diagnostic Service		Function
Service \$01	READINESS TESTS	This diagnostic service gains access to current emission-related data values, including analog inputs and outputs, digital inputs and outputs, and system status information.
Service \$02	(FREEZE DATA)	This diagnostic service gains access to emission-related data value that were stored by ECM during the freeze frame. For details, refer to EC-521, "DTC Index" .
Service \$03	DTCs	This diagnostic service gains access to emission-related power train trouble codes which were stored by ECM.
Service \$04	CLEAR DIAG INFO	This diagnostic service can clear all emission-related diagnostic information. This includes: <ul style="list-style-type: none"> • Clear number of diagnostic trouble codes (Service \$01) • Clear diagnostic trouble codes (Service \$03) • Clear trouble code for freeze frame data (Service \$01) • Clear freeze frame data (Service \$02) • Reset status of system monitoring test (Service \$01) • Clear on board monitoring test results (Service \$06 and \$07)
Service \$06	(ON BOARD TESTS)	This diagnostic service accesses the results of on board diagnostic monitoring tests of specific components/systems that are not continuously monitored.
Service \$07	(ON BOARD TESTS)	This diagnostic service enables the off board test drive to obtain test results for emission-related powertrain components/systems that are continuously monitored during normal driving conditions.
Service \$08	—	This diagnostic service can close EVAP system in ignition switch ON position (Engine stopped). When this diagnostic service is performed, EVAP canister vent control valve can be closed. In the following conditions, this diagnostic service cannot function. <ul style="list-style-type: none"> • Low ambient temperature • Low battery voltage • Engine running • Ignition switch OFF • Low fuel temperature • Too much pressure is applied to EVAP system
Service \$09	(CALIBRATION ID)	This diagnostic service enables the off-board test device to request specific vehicle information such as Vehicle Identification Number (VIN) and Calibration IDs.

INSPECTION PROCEDURE

1. Turn ignition switch OFF.
2. Connect "GST" to data link connector (2), which is located under LH dash panel.

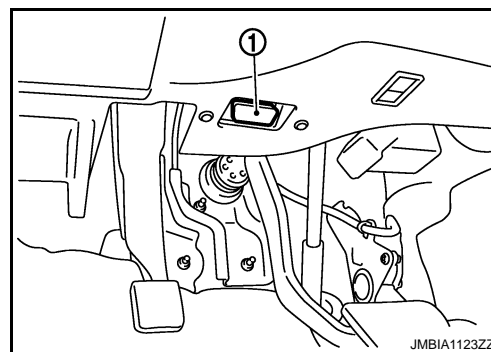

3. Turn ignition switch ON.

ON BOARD DIAGNOSTIC (OBD) SYSTEM

[VQ35DE]

< FUNCTION DIAGNOSIS >

4. Enter the program according to instruction on the screen or in the operation manual.
(*: Regarding GST screens in this section, sample screens are shown.)

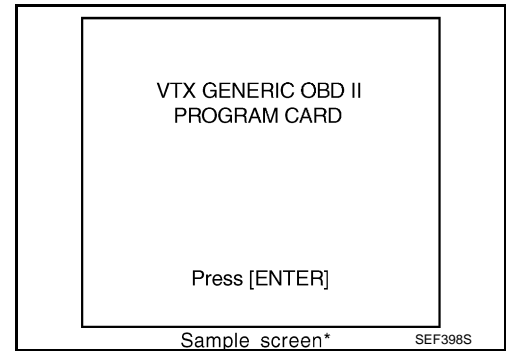

5. Perform each diagnostic mode according to each service procedure.
For further information, see the GST Operation Manual of the tool maker.

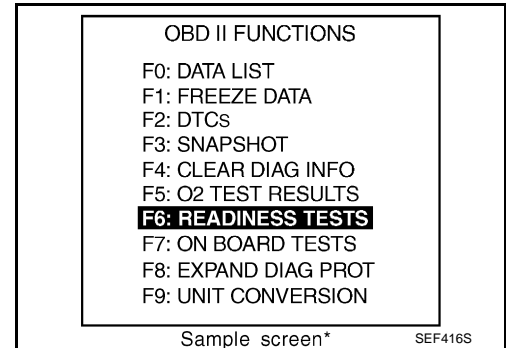

COMPONENT DIAGNOSIS

TROUBLE DIAGNOSIS - SPECIFICATION VALUE

Description

INFOID:000000003387929

The specification (SP) value indicates the tolerance of the value that is displayed in "SPEC" in "DATA MONITOR" mode of CONSULT-III during normal operation of the Engine Control System. When the value in "SPEC" in "DATA MONITOR" mode is within the SP value, the Engine Control System is confirmed OK. When the value in "SPEC" in "DATA MONITOR" mode is NOT within the SP value, the Engine Control System may have one or more malfunctions.

The SP value is used to detect malfunctions that may affect the Engine Control System, but will not illuminate the MIL.

The SP value will be displayed for the following three items:

- B/FUEL SCHDL (The fuel injection pulse width programmed into ECM prior to any learned on board correction)
- A/F ALPHA-B1/B2 (The mean value of air-fuel ratio feedback correction factor per cycle)
- MAS A/F SE-B1 (The signal voltage of the mass air flow sensor)

Component Function Check

INFOID:000000003387930

1. START

Check that all of the following conditions are satisfied.

- Vehicle driven distance: More than 5,000 km (3,107 miles)
- Barometric pressure: 98.3 - 104.3 kPa (1.003 - 1.064 kg/cm², 14.25 - 15.12 psi)
- Atmospheric temperature: 20 - 30°C (68 - 86°F)
- Engine coolant temperature: 75 - 95°C (167 - 203°F)
- Transmission: Warmed-up
 - After the engine is warmed up to normal operating temperature, drive vehicle until "FLUID TEMP SE" (CVT fluid temperature sensor signal) indicates more than 60°C (140°F).
- Electrical load: Not applied
 - Rear window defogger switch, air conditioner switch lighting switch are OFF. Steering wheel is straight ahead.
- Engine speed: Idle

>> GO TO 2.

2. PERFORM "SPEC" OF "DATA MONITOR" MODE

With CONSULT-III

NOTE:

Perform "SPEC" in "DATA MONITOR" mode in maximum scale display.

1. Perform "[EC-12. "BASIC INSPECTION : Special Repair Requirement"](#)".
2. Select "B/FUEL SCHDL", "A/F ALPHA-B1", "A/F ALPHA-B2" and "MAS A/F SE-B1" in "SPEC" of "DATA MONITOR" mode with CONSULT-III.
3. Check that monitor items are within the SP value.

Is the measurement value within the SP value?

- YES >> INSPECTION END
 NO >> Go to [EC-128. "Diagnosis Procedure"](#).

TROUBLE DIAGNOSIS - SPECIFICATION VALUE

< COMPONENT DIAGNOSIS >

[VQ35DE]

Diagnosis Procedure

INFOID:000000003387931

OVERALL SEQUENCE

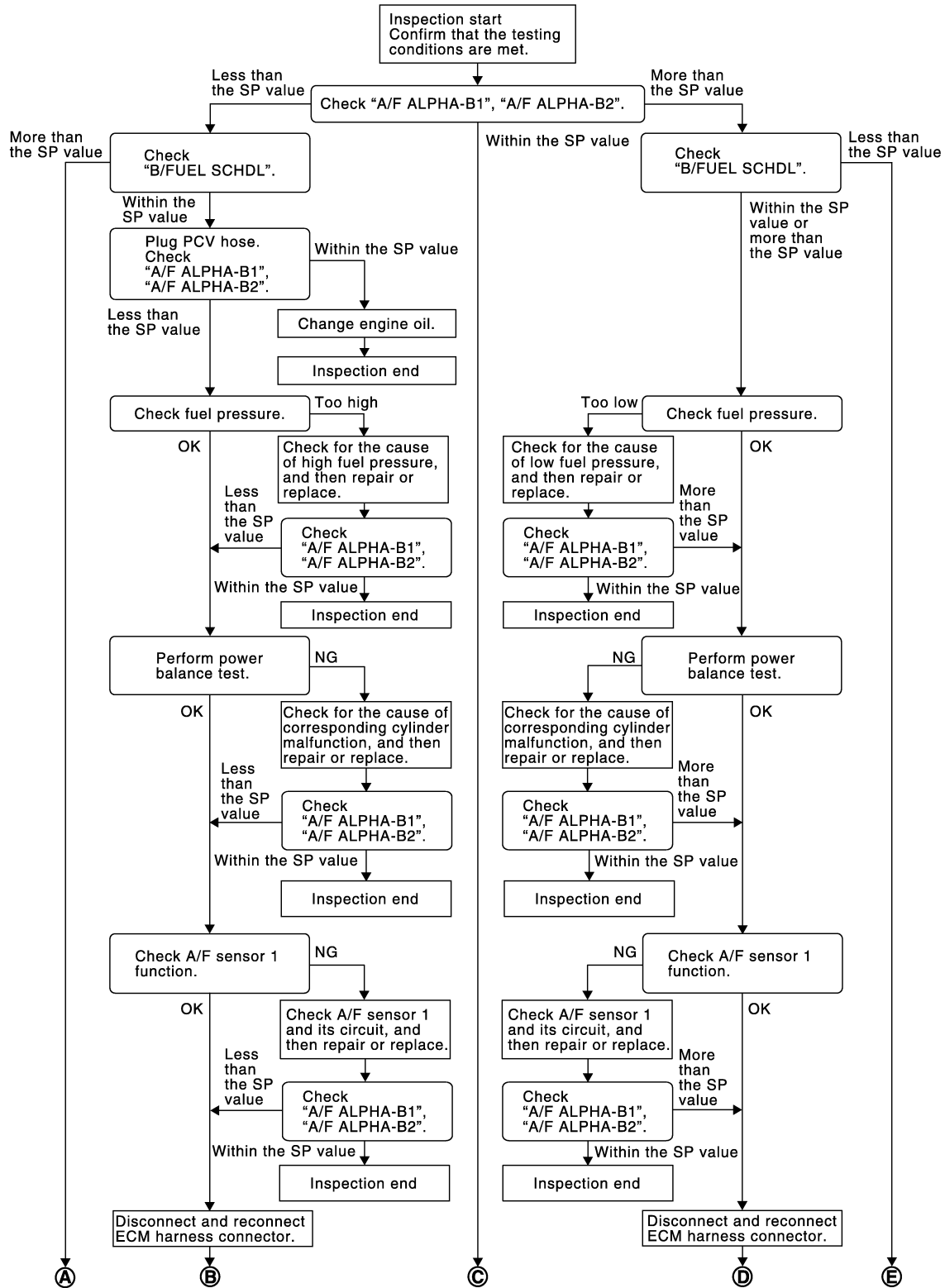

JMBIA1468GB

TROUBLE DIAGNOSIS - SPECIFICATION VALUE

< COMPONENT DIAGNOSIS >

[VQ35DE]

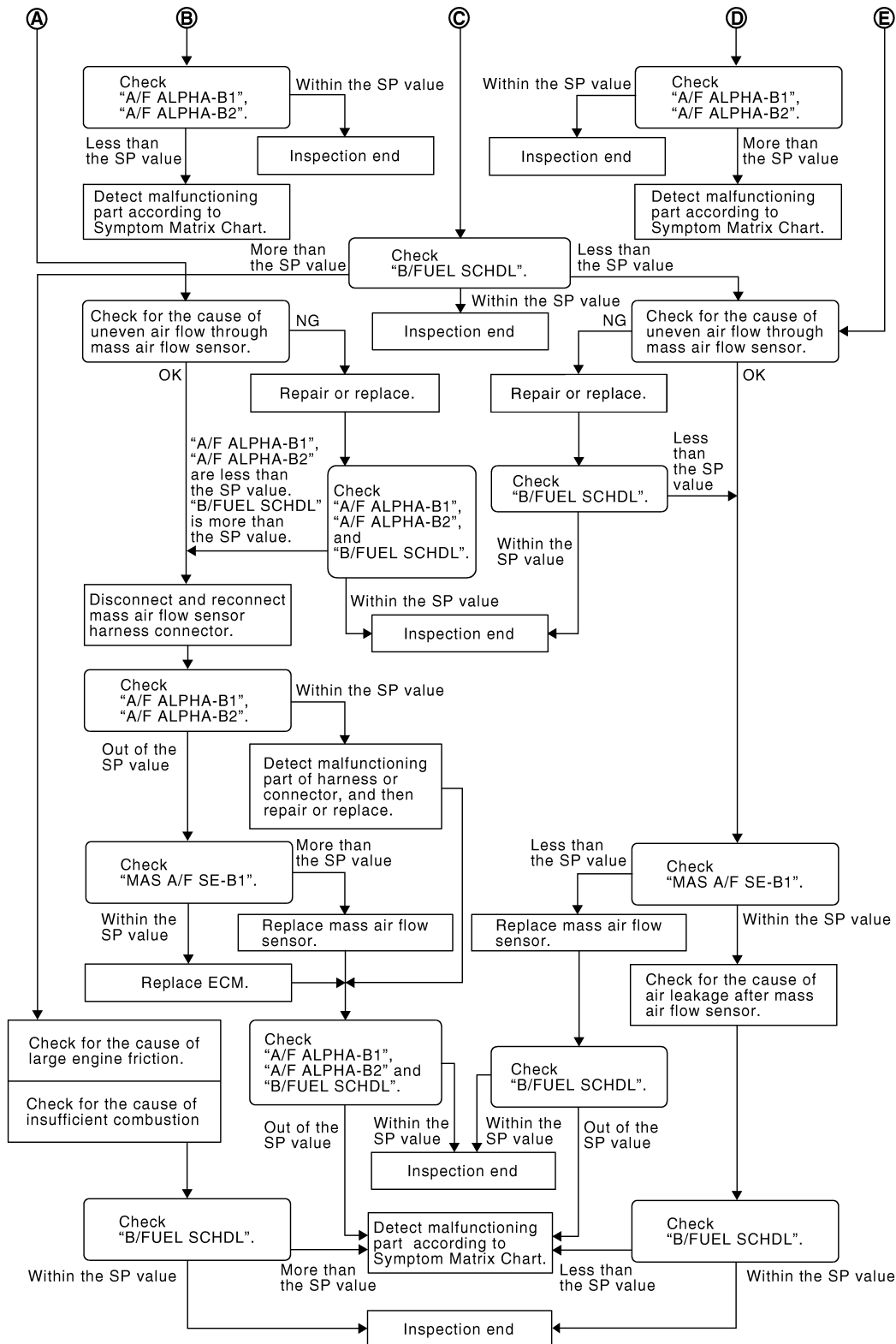

FBI3214E

DETAILED PROCEDURE

1. CHECK "A/F ALPHA-B1", "A/F ALPHA-B2"

④ With CONSULT-III

1. Start engine.
2. Confirm that the testing conditions are met. Refer to [EC-127, "Component Function Check"](#).
3. Select "A/F ALPHA-B1", "A/F ALPHA-B2" in "SPEC" of "DATA MONITOR" mode, and check that each indication is within the SP value.

TROUBLE DIAGNOSIS - SPECIFICATION VALUE

[VQ35DE]

< COMPONENT DIAGNOSIS >

NOTE:

Check "A/F ALPHA-B1", "A/F ALPHA-B2" for approximately 1 minute because they may fluctuate. It is NG if the indication is out of the SP value even a little.

Is the measurement value within the SP value?

- YES >> GO TO 17.
NO-1 >> Less than the SP value: GO TO 2.
NO-2 >> More than the SP value: GO TO 3.

2.CHECK "B/FUEL SCHDL"

Select "B/FUEL SCHDL" in "SPEC" of "DATA MONITOR" mode, and check that the indication is within the SP value.

Is the measurement value within the SP value?

- YES >> GO TO 4.
NO >> More than the SP value: GO TO 19.

3.CHECK "B/FUEL SCHDL"

Select "B/FUEL SCHDL" in "SPEC" of "DATA MONITOR" mode, and check that the indication is within the SP value.

Is the measurement value within the SP value?

- YES >> GO TO 6.
NO-1 >> More than the SP value: GO TO 6.
NO-2 >> Less than the SP value: GO TO 25.

4.CHECK "A/F ALPHA-B1", "A/F ALPHA-B2"

1. Stop the engine.
2. Disconnect PCV hose, and then plug it.
3. Start engine.
4. Select "A/F ALPHA-B1", "A/F ALPHA-B2" in "SPEC" of "DATA MONITOR" mode, and check that each indication is within the SP value.

Is the measurement value within the SP value?

- YES >> GO TO 5.
NO >> GO TO 6.

5.CHANGE ENGINE OIL

1. Stop the engine.
2. Change engine oil.

NOTE:

This symptom may occur when a large amount of gasoline is mixed with engine oil because of driving conditions (such as when engine oil temperature does not rise enough since a journey distance is too short during winter). The symptom will not be detected after changing engine oil or changing driving conditions.

>> INSPECTION END

6.CHECK FUEL PRESSURE

Check fuel pressure. (Refer to [EC-545. "Inspection".](#))

Is the inspection result normal?

- YES >> GO TO 9.
NO-1 >> Fuel pressure is too high: Replace "fuel filter and fuel pump assembly" and then. GO TO 8.
NO-2 >> Fuel pressure is too low: GO TO 7.

7.DETECT MALFUNCTIONING PART

Check fuel hoses and fuel tubes for clogging.

Is the inspection result normal?

- YES >> Replace "fuel filter and fuel pump assembly" and then GO TO 8.
NO >> Repair or replace malfunctioning part and then GO TO 8.

8.CHECK "A/F ALPHA-B1", "A/F ALPHA-B2"

TROUBLE DIAGNOSIS - SPECIFICATION VALUE

[VQ35DE]

< COMPONENT DIAGNOSIS >

1. Start engine.
2. Select "A/F ALPHA-B1", "A/F ALPHA-B2" in "SPEC" of "DATA MONITOR" mode, and check that each indication is within the SP value.

Is the measurement value within the SP value?

- YES >> INSPECTION END
NO >> GO TO 9.

9.PERFORM POWER BALANCE TEST

1. Perform "POWER BALANCE" in "ACTIVE TEST" mode.
2. Check that the each cylinder produces a momentary engine speed drop.

Is the inspection result normal?

- YES >> GO TO 12.
NO >> GO TO 10.

10.DETECT MALFUNCTIONING PART

Check the following below.

- Ignition coil and its circuit (Refer to [EC-451, "Component Function Check"](#).)
- Fuel injector and its circuit (Refer to [EC-444, "Component Function Check"](#).)
- Intake air leakage
- Low compression pressure (Refer to [EM-23, "Inspection"](#).)

Is the inspection result normal?

- YES >> Replace fuel injector and then GO TO 11.
NO >> Repair or replace malfunctioning part and then GO TO 11.

11.CHECK "A/F ALPHA-B1", "A/F ALPHA-B2"

1. Start engine.
2. Select "A/F ALPHA-B1", "A/F ALPHA-B2" in "SPEC" of "DATA MONITOR" mode, and check that each indication is within the SP value.

Is the measurement value within the SP value?

- YES >> INSPECTION END
NO >> GO TO 12.

12.CHECK A/F SENSOR 1 FUNCTION

Perform all DTC CONFIRMATION PROCEDURE related with A/F sensor 1.

- For DTC P0130, P0150, refer to [EC-186, "DTC Logic"](#).
- For DTC P0131, P0151, refer to [EC-190, "DTC Logic"](#).
- For DTC P0132, P0152, refer to [EC-194, "DTC Logic"](#).
- For DTC P0133, P0153, refer to [EC-198, "DTC Logic"](#).
- For DTC P2A00, P2A03, refer to [EC-427, "DTC Logic"](#).

Are any DTCs detected?

- YES >> GO TO 15.
NO >> GO TO 13.

13.CHECK A/F SENSOR 1 CIRCUIT

Perform Diagnostic Procedure according to corresponding DTC.

>> GO TO 14.

14.CHECK "A/F ALPHA-B1", "A/F ALPHA-B2"

1. Start engine.
2. Select "A/F ALPHA-B1", "A/F ALPHA-B2" in "SPEC" of "DATA MONITOR" mode, and check that each indication is within the SP value.

Is the measurement value within the SP value?

- YES >> INSPECTION END
NO >> GO TO 15.

15.DISCONNECT AND RECONNECT ECM HARNESS CONNECTOR

1. Stop the engine.

TROUBLE DIAGNOSIS - SPECIFICATION VALUE

[VQ35DE]

< COMPONENT DIAGNOSIS >

2. Disconnect ECM harness connector. Check pin terminal and connector for damage, and then reconnect it.

>> GO TO 16.

16.CHECK "A/F ALPHA-B1", "A/F ALPHA-B2"

1. Start engine.
2. Select "A/F ALPHA-B1", "A/F ALPHA-B2" in "SPEC" of "DATA MONITOR" mode, and check that each indication is within the SP value.

Is the measurement value within the SP value?

YES >> INSPECTION END

NO >> Detect malfunctioning part according to [EC-533. "Symptom Table"](#).

17.CHECK "B/FUEL SCHDL"

Select "B/FUEL SCHDL" in "SPEC" of "DATA MONITOR" mode, and check that the indication is within the SP value.

Is the measurement value within the SP value?

YES >> INSPECTION END

NO-1 >> More than the SP value: GO TO 18.

NO-2 >> Less than the SP value: GO TO 25.

18.DETECT MALFUNCTIONING PART

1. Check for the cause of large engine friction. Refer to the following.
 - Engine oil level is too high
 - Engine oil viscosity
 - Belt tension of power steering, alternator, A/C compressor, etc. is excessive
 - Noise from engine
 - Noise from transmission, etc.
2. Check for the cause of insufficient combustion. Refer to the following.
 - Valve clearance malfunction
 - Intake valve timing control function malfunction
 - Camshaft sprocket installation malfunction, etc.

>> Repair or replace malfunctioning part, and then GO TO 30.

19.CHECK INTAKE SYSTEM

Check for the cause of uneven air flow through mass air flow sensor. Refer to the following.

- Crushed air ducts
- Malfunctioning seal of air cleaner element
- Uneven dirt of air cleaner element
- Improper specification of intake air system

Is the inspection result normal?

YES >> GO TO 21.

NO >> Repair or replace malfunctioning part, and then GO TO 20.

20.CHECK "A/F ALPHA-B1", "A/F ALPHA-B2", AND "B/FUEL SCHDL"

Select "A/F ALPHA-B1", "A/F ALPHA-B2", and "B/FUEL SCHDL" in "SPEC" of "DATA MONITOR" mode, and check that each indication is within the SP value.

Is the measurement value within the SP value?

YES >> INSPECTION END

NO >> "B/FUEL SCHDL" is more, "A/F ALPHA-B1", "A/F ALPHA-B2" are less than the SP value: GO TO 21.

21.DISCONNECT AND RECONNECT MASS AIR FLOW SENSOR HARNESS CONNECTOR

1. Stop the engine.
2. Disconnect mass air flow sensor harness connector. Check pin terminal and connector for damage and then reconnect it again.

>> GO TO 22.

TROUBLE DIAGNOSIS - SPECIFICATION VALUE

< COMPONENT DIAGNOSIS >

[VQ35DE]

22.CHECK "A/F ALPHA-B1", "A/F ALPHA-B2"

1. Start engine.
2. Select "A/F ALPHA-B1", "A/F ALPHA-B2" in "SPEC" of "DATA MONITOR" mode, and check that each indication is within the SP value.

Is the measurement value within the SP value?

YES >> Detect malfunctioning part of mass air flow sensor circuit and repair it. Refer to [EC-163, "Diagnosis Procedure"](#). Then GO TO 29.

NO >> GO TO 23.

23.CHECK "MAS A/F SE-B1"

Select "MAS A/F SE-B1" in "SPEC" of "DATA MONITOR" mode, and check that the indication is within the SP value.

Is the measurement value within the SP value?

YES >> GO TO 24.

NO >> More than the SP value: Replace mass air flow sensor, and then GO TO 29.

24.REPLACE ECM

1. Replace ECM.
2. Refer to [EC-15, "ADDITIONAL SERVICE WHEN REPLACING CONTROL UNIT : Special Repair Requirement"](#).

>> GO TO 29.

25.CHECK INTAKE SYSTEM

Check for the cause of uneven air flow through mass air flow sensor. Refer to the following.

- Crushed air ducts
- Malfunctioning seal in air cleaner element
- Uneven dirt in air cleaner element
- Improper specification in intake air system

Is the inspection result normal?

YES >> GO TO 27.

NO >> Repair or replace malfunctioning part, and then GO TO 26.

26.CHECK "B/FUEL SCHDL"

Select "B/FUEL SCHDL" in "SPEC" of "DATA MONITOR" mode, and check that the indication is within the SP value.

Is the measurement value within the SP value?

YES >> INSPECTION END

NO >> Less than the SP value: GO TO 27.

27.CHECK "MAS A/F SE-B1"

Select "MAS A/F SE-B1" in "SPEC" of "DATA MONITOR" mode, and check that the indication is within the SP value.

Is the measurement value within the SP value?

YES >> GO TO 28.

NO >> Less than the SP value: Replace mass air flow sensor, and then GO TO 30.

28.CHECK INTAKE SYSTEM

Check for the cause of air leakage after the mass air flow sensor. Refer to the following.

- Disconnection, looseness, and cracks in air duct
- Looseness of oil filler cap
- Disconnection of oil level gauge
- Open stuck, breakage, hose disconnection, or cracks in PCV valve
- Disconnection or cracks in EVAP purge hose, stuck open EVAP canister purge volume control solenoid valve
- Malfunctioning seal in rocker cover gasket
- Disconnection, looseness, or cracks in hoses, such as a vacuum hose, connecting to intake air system parts

TROUBLE DIAGNOSIS - SPECIFICATION VALUE

< COMPONENT DIAGNOSIS >

[VQ35DE]

- Malfunctioning seal in intake air system, etc.

>> GO TO 30.

29.CHECK "A/F ALPHA-B1", "A/F ALPHA-B2", AND "B/FUEL SCHDL"

Select "A/F ALPHA-B1", "A/F ALPHA-B2", and "B/FUEL SCHDL" in "SPEC" of "DATA MONITOR" mode, and check that each indication is within the SP value.

Is the measurement value within the SP value?

YES >> INSPECTION END

NO >> Detect malfunctioning part according to [EC-533. "Symptom Table"](#).

30.CHECK "B/FUEL SCHDL"

Select "B/FUEL SCHDL" in "SPEC" of "DATA MONITOR" mode, and then check that the indication is within the SP value.

Is the measurement value within the SP value?

YES >> INSPECTION END

NO >> Detect malfunctioning part according to [EC-533. "Symptom Table"](#).

POWER SUPPLY AND GROUND CIRCUIT

< COMPONENT DIAGNOSIS >

[VQ35DE]

POWER SUPPLY AND GROUND CIRCUIT

Diagnosis Procedure

INFOID:000000004752070

1. CHECK GROUND CONNECTION

1. Turn ignition switch OFF.
2. Check ground connection E38. Refer to Ground Inspection in [GI-43, "Circuit Inspection"](#).

Is the inspection result normal?

- YES >> GO TO 2.
NO >> Repair or replace ground connection.

2. CHECK ECM GROUND CIRCUIT FOR OPEN AND SHORT

1. Disconnect ECM harness connector.
2. Check the continuity between ECM harness connector and ground.

ECM		Ground	Continuity
Connector	Terminal		
F7	12	Ground	Existed
	16		
E16	107		
	108		
	111		
	112		

3. Also check harness for short to power.

is the inspection result normal?

- YES >> GO TO 4.
NO >> GO TO 3.

3. DETECT MALFUNCTIONING PART

Check the following.

- Harness connectors F121, E7
- Harness for open or short between ECM and ground

>> Repair open circuit or short to power in harness or connectors.

4. CHECK ECM POWER SUPPLY CIRCUIT-I

1. Reconnect ECM harness connector.
2. Turn ignition switch OFF and then ON.
3. Check the voltage between ECM harness connector terminals.

ECM			Voltage
Connector	+	-	
	Terminal	Terminal	
E16	93	112	Battery voltage

Is the inspection result normal?

- YES >> GO TO 6.
NO >> GO TO 5.

5. DETECT MALFUNCTIONING PART

Check the following.

- IPDM E/R connector E10
- 10 A fuse (No. 44)
- Harness for open or short between ECM and IPDM E/R

POWER SUPPLY AND GROUND CIRCUIT

[VQ35DE]

< COMPONENT DIAGNOSIS >

>> Repair open circuit, short to ground or short to power in harness or connectors.

6. CHECK ECM POWER SUPPLY CIRCUIT-II

Check the voltage between ECM harness connector terminals.

ECM			Condition	Voltage
Connector	+	-		
	Terminal	Terminal		
E16	105	112	Ignition switch ON → OFF	After turning ignition switch OFF, battery voltage will exist for a few seconds, then drop to approximately 0 V.

Is the inspection result normal?

YES >> GO TO 7.

NO >> GO TO 9.

7. CHECK ECM POWER SUPPLY CIRCUIT-III

1. Turn ignition switch ON.
2. Check the voltage between IPDM E/R harness connector and ground.

IPDM E/R		Ground	Voltage
Connector	Terminal		
F12	49	Ground	Battery voltage
	53		

Is the inspection result normal?

YES >> GO TO 8.

NO >> Replace IPDM E/R.

8. CHECK INTERMITTENT INCIDENT

Refer to [GI-40. "Intermittent Incident"](#).

>> INSPECTION END

9. CHECK ECM POWER SUPPLY CIRCUIT-IV

1. Turn ignition switch OFF and wait at least 10 seconds.
2. Check the voltage between ECM harness connector terminals.

ECM				Voltage
+		-		
Connector	Terminal	Connector	Terminal	
F7	24	E16	112	Battery voltage

Is the inspection result normal?

YES >> GO TO 12.

NO >> GO TO 10.

10. CHECK ECM POWER SUPPLY CIRCUIT-V

1. Disconnect ECM harness connector.
2. Disconnect IPDM E/R harness connector.
3. Check the continuity between ECM harness connector and IPDM E/R harness connector.

ECM		IPDM E/R		Continuity
Connector	Terminal	Connector	Terminal	
F7	24	F12	69	Existed

POWER SUPPLY AND GROUND CIRCUIT

[VQ35DE]

< COMPONENT DIAGNOSIS >

4. Also check harness for short to ground and short to power.

Is the inspection result normal?

YES >> GO TO 11.

NO >> Repair open circuit, short to ground or short to power in harness or connectors.

11.CHECK 15 A FUSE

1. Disconnect 15 A fuse (No. 50) from IPDM E/R.

2. Check 15 A fuse.

Is the inspection result normal?

YES >> GO TO 13.

NO >> Replace 15 A fuse.

12.CHECK ECM POWER SUPPLY CIRCUIT-VI

1. Disconnect ECM harness connector.

2. Disconnect IPDM E/R harness connector.

3. Check the continuity between ECM harness connector and IPDM E/R harness connector.

ECM		IPDM E/R		Continuity
Connector	Terminal	Connector	Terminal	
E16	105	E10	10	Existed

4. Also check harness for short to ground and short to power.

Is the inspection result normal?

YES >> GO TO 13.

NO >> Repair open circuit, short to ground or short to power in harness or connectors.

13.CHECK INTERMITTENT INCIDENT

Refer to [GI-40. "Intermittent Incident"](#).

Is the inspection result normal?

YES >> Replace IPDM E/R.

NO >> Repair or replace harness or connectors.

A
EC
C
D
E
F
G
H
I
J
K
L
M
N
O
P

U0101 CAN COMM CIRCUIT

< COMPONENT DIAGNOSIS >

[VQ35DE]

U0101 CAN COMM CIRCUIT

Description

INFOID:000000004734288

CAN (Controller Area Network) is a serial communication line for real time application. It is an on-vehicle multiplex communication line with high data communication speed and excellent error detection ability. Many electronic control units are equipped onto a vehicle, and each control unit shares information and links with other control units during operation (not independent). In CAN communication, control units are connected with 2 communication lines (CAN H line, CAN L line) allowing a high rate of information transmission with less wiring. Each control unit transmits/receives data but selectively reads required data only.

DTC Logic

INFOID:000000004734289

DTC DETECTION LOGIC

DTC No.	Trouble diagnosis name	DTC detecting condition	Possible cause
U0101	Lost communication with TCM	When ECM is not transmitting or receiving CAN communication signal of OBD (emission-related diagnosis) with TCM for 2 seconds or more.	<ul style="list-style-type: none">• CAN communication line between TCM and ECM• CAN communication line open or shorted

DTC CONFIRMATION PROCEDURE

1. PERFORM DTC CONFIRMATION PROCEDURE

1. Turn ignition switch ON and wait at least 3 seconds.
2. Check DTC.

Is DTC detected?

- YES >> [EC-138, "Diagnosis Procedure"](#).
NO >> INSPECTION END

Diagnosis Procedure

INFOID:000000004734290

Go to [LAN-16, "Trouble Diagnosis Flow Chart"](#).

U0164 CAN COMM CIRCUIT

< COMPONENT DIAGNOSIS >

[VQ35DE]

U0164 CAN COMM CIRCUIT

Description

INFOID:000000004734291

CAN (Controller Area Network) is a serial communication line for real time application. It is an on-vehicle multiplex communication line with high data communication speed and excellent error detection ability. Many electronic control units are equipped onto a vehicle, and each control unit shares information and links with other control units during operation (not independent). In CAN communication, control units are connected with 2 communication lines (CAN H line, CAN L line) allowing a high rate of information transmission with less wiring. Each control unit transmits/receives data but selectively reads required data only.

DTC Logic

INFOID:000000004734292

DTC DETECTION LOGIC

DTC No.	Trouble diagnosis name	DTC detecting condition	Possible cause
U0164	Lost communication with Unified meter and A/C amp.	When ECM is not transmitting or receiving CAN communication signal of OBD (emission related diagnosis) with Unified meter and A/C amp. for 2 seconds or more.	<ul style="list-style-type: none">• CAN communication line between Unified meter and A/C amp. and ECM• CAN communication line open or shorted

DTC CONFIRMATION PROCEDURE

1. PERFORM DTC CONFIRMATION PROCEDURE

1. Turn ignition switch ON and wait at least 3 seconds.
2. Check DTC.

Is DTC detected?

- YES >> [EC-139, "Diagnosis Procedure"](#).
NO >> INSPECTION END

Diagnosis Procedure

INFOID:000000004734293

Go to [LAN-16, "Trouble Diagnosis Flow Chart"](#).

U1000, U1001 CAN COMM CIRCUIT

< COMPONENT DIAGNOSIS >

[VQ35DE]

U1000, U1001 CAN COMM CIRCUIT

Description

INFOID:000000003387933

CAN (Controller Area Network) is a serial communication line for real time application. It is an on-vehicle multiplex communication line with high data communication speed and excellent error detection ability. Many electronic control units are equipped onto a vehicle, and each control unit shares information and links with other control units during operation (not independent). In CAN communication, control units are connected with 2 communication lines (CAN H line, CAN L line) allowing a high rate of information transmission with less wiring. Each control unit transmits/receives data but selectively reads required data only.

DTC Logic

INFOID:000000003387934

DTC DETECTION LOGIC

DTC No.	Trouble diagnosis name	DTC detecting condition	Possible cause
U1000	CAN communication line	When ECM is not transmitting or receiving CAN communication signal of OBD (emission related diagnosis) for 2 seconds or more.	• Harness or connectors (CAN communication line is open or shorted)
U1001		When ECM is not transmitting or receiving CAN communication signal other than OBD (emission related diagnosis) for 2 seconds or more.	

DTC CONFIRMATION PROCEDURE

1. PERFORM DTC CONFIRMATION PROCEDURE

1. Turn ignition switch ON and wait at least 3 seconds.
2. Check DTC.

Is DTC detected?

- YES >> [EC-140. "Diagnosis Procedure"](#).
NO >> INSPECTION END

Diagnosis Procedure

INFOID:000000003387935

Go to [LAN-16. "Trouble Diagnosis Flow Chart"](#).

P0011, P0021 IVT CONTROL

DTC Logic

INFOID:000000003387939

DTC DETECTION LOGIC

NOTE:

If DTC P0011 or P0021 is displayed with DTC P0075 or P0081, first perform the trouble diagnosis for DTC P0075, P0081. Refer to [EC-151, "DTC Logic"](#).

DTC No.	Trouble diagnosis name	DTC detecting condition	Possible cause
P0011	Intake valve timing control performance (bank 1)	There is a gap between angle of target and phase-control angle degree.	<ul style="list-style-type: none"> • Crankshaft position sensor (POS) • Camshaft position sensor (PHASE) • Intake valve timing control solenoid valve • Accumulation of debris to the signal pick-up portion of the camshaft • Timing chain installation • Foreign matter caught in the oil groove for intake valve timing control
P0021	Intake valve timing control performance (bank 2)		

DTC CONFIRMATION PROCEDURE

1. PRECONDITIONING

If DTC Confirmation Procedure has been previously conducted, always perform the following before conducting the next test.

1. Turn ignition switch OFF and wait at least 10 seconds.
2. Turn ignition switch ON.
3. Turn ignition switch OFF and wait at least 10 seconds.

TESTING CONDITION:

Before performing the following procedure, confirm that battery voltage is between 10 V and 16 V at idle.

>> GO TO 2.

2. PERFORM DTC CONFIRMATION PROCEDURE-I

 With CONSULT-III

1. Turn ignition switch ON and select "DATA MONITOR" mode with CONSULT-III.
2. Start engine and warm it up to the normal operating temperature.
3. Maintain the following conditions for at least 6 consecutive seconds. Hold the accelerator pedal as steady as possible.

VHCL SPEED SE	100 - 120 km/h (63 - 75 mph)
ENG SPEED	2,000 - 4,000 rpm
COOLAN TEMP/S	More than 60°C (140°F)
B/FUEL SCHDL	More than 7.3 msec
Selector lever	D position

CAUTION:

Always drive at a safe speed.

4. Stop vehicle with engine running and let engine idle for 10 seconds.
5. Check 1st trip DTC.

 With GST

Follow the procedure "With CONSULT-III" above.

Is 1st trip DTC detected?

- YES >> Go to [EC-142, "Diagnosis Procedure"](#)
 NO >> GO TO 3.

3. PERFORM DTC CONFIRMATION PROCEDURE-II

P0011, P0021 IVT CONTROL

< COMPONENT DIAGNOSIS >

[VQ35DE]

ⓑ With CONSULT-III

1. Maintain the following conditions for at least 20 consecutive seconds.

ENG SPEED	1,400 - 3,175 rpm (A constant rotation is maintained.)
COOLAN TEMP/S	More than 70°C (158°F)
Selector lever	1st or 2nd position
Driving location uphill	Driving vehicle uphill (Increased engine load will help maintain the driving conditions required for this test.)

CAUTION:

Always drive at a safe speed.

2. Check 1st trip DTC.

ⓐ With GST

Follow the procedure "With CONSULT-III" above.

Is 1st trip DTC detected?

- YES >> Go to [EC-142, "Diagnosis Procedure"](#)
NO >> INSPECTION END

Diagnosis Procedure

INFOID:000000003387940

1. CHECK OIL PRESSURE WARNING LAMP

1. Start engine.
2. Check oil pressure warning lamp and confirm it is not illuminated.

Is oil pressure warning lamp illuminated?

- YES >> Go to [LU-7, "Inspection"](#).
NO >> GO TO 2.

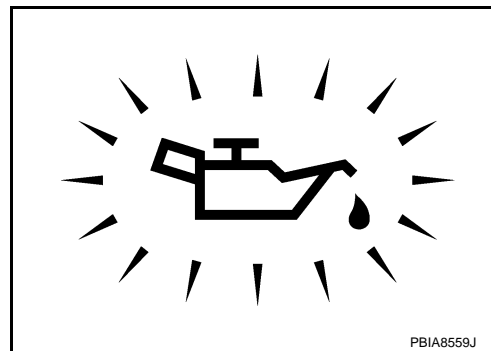

2. CHECK INTAKE VALVE TIMING CONTROL SOLENOID VALVE

Refer to [EC-143, "Component Inspection"](#).

Is the inspection result normal?

- YES >> GO TO 3.
NO >> Replace malfunctioning intake valve timing control solenoid valve.

3. CHECK CRANKSHAFT POSITION SENSOR (POS)

Refer to [EC-263, "Component Inspection"](#).

Is the inspection result normal?

- YES >> GO TO 4.
NO >> Replace crankshaft position sensor (POS).

4. CHECK CAMSHAFT POSITION SENSOR (PHASE)

Refer to [EC-266, "Component Inspection"](#).

Is the inspection result normal?

- YES >> GO TO 5.
NO >> Replace malfunctioning camshaft position sensor (PHASE).

5. CHECK CAMSHAFT (INTAKE)

Check the following.

P0011, P0021 IVT CONTROL

[VQ35DE]

< COMPONENT DIAGNOSIS >

- Accumulation of debris on the signal plate of camshaft rear end
- Chipping signal plate of camshaft rear end

Is the inspection result normal?

- YES >> GO TO 6.
 NO >> Remove debris and clean the signal plate of camshaft rear end or replace camshaft.

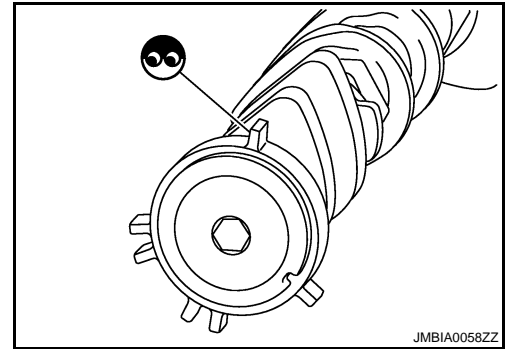

6.CHECK TIMING CHAIN INSTALLATION

Check service records for any recent repairs that may cause timing chain misalignment.

Are there any service records that may cause timing chain misalignment?

- YES >> Check timing chain installation. Refer to [EM-54, "Removal and Installation"](#).
 NO >> GO TO 7.

7.CHECK LUBRICATION CIRCUIT

Refer to [EM-18, "Inspection and Adjustment"](#).

Is the inspection result normal?

- YES >> GO TO 8.
 NO >> Clean lubrication line.

8.CHECK INTERMITTENT INCIDENT

Refer to [GI-40, "Intermittent Incident"](#).

>> INSPECTION END

Component Inspection

INFOID:000000003387941

1.CHECK INTAKE VALVE TIMING CONTROL SOLENOID VALVE-I

1. Disconnect intake valve timing control solenoid valve harness connector.
2. Check resistance between intake valve timing control solenoid valve terminals as per the following.

Terminals	Resistance
1 and 2	7.0 - 7.5 Ω [at 20°C (68°F)]
1 or 2 and ground	∞Ω (Continuity should not exist)

Is the inspection result normal?

- YES >> GO TO 2.
 NO >> Replace malfunctioning intake valve timing control solenoid valve.

2.CHECK INTAKE VALVE TIMING CONTROL SOLENOID VALVE-II

1. Remove intake valve timing control solenoid valve.
2. Provide 12 V DC between intake valve timing control solenoid valve terminals 1 and 2, and then interrupt it. Check that the plunger moves as shown in the figure.

CAUTION:

Never apply 12 V DC continuously for 5 seconds or more. Doing so may result in damage to the coil in intake valve timing control solenoid valve.

NOTE:

Always replace O-ring when intake valve timing control solenoid valve is removed.

Is the inspection result normal?

- YES >> INSPECTION END

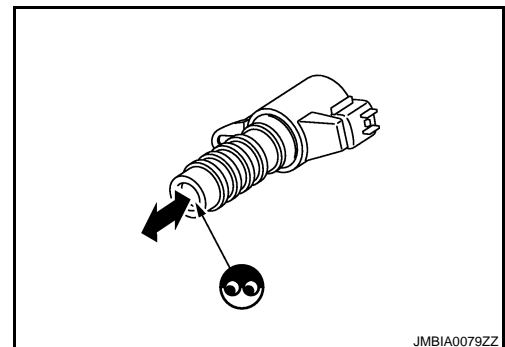

P0011, P0021 IVT CONTROL

< COMPONENT DIAGNOSIS >

[VQ35DE]

NO >> Replace malfunctioning intake valve timing control solenoid valve.

P0031, P0032, P0051, P0052 A/F SENSOR 1 HEATER

< COMPONENT DIAGNOSIS >

[VQ35DE]

P0031, P0032, P0051, P0052 A/F SENSOR 1 HEATER

Description

INFOID:000000003387942

SYSTEM DESCRIPTION

Sensor	Input signal to ECM	ECM function	Actuator
Camshaft position sensor (PHASE) Crankshaft position sensor (POS)	Engine speed	Air fuel ratio (A/F) sensor 1 heater control	Air fuel ratio (A/F) sensor 1 heater
Mass air flow sensor	Amount of intake air		

The ECM performs ON/OFF duty control of the A/F sensor 1 heater corresponding to the engine operating condition to keep the temperature of A/F sensor 1 element within the specified range.

DTC Logic

INFOID:000000003387943

DTC DETECTION LOGIC

DTC No.	Trouble diagnosis name	DTC detecting condition	Possible cause
P0031	Air fuel ratio (A/F) sensor 1 heater (bank 1) control circuit low	The current amperage in the A/F sensor 1 heater circuit is out of the normal range. (An excessively low voltage signal is sent to ECM through the A/F sensor 1 heater.)	<ul style="list-style-type: none">• Harness or connectors (The A/F sensor 1 heater circuit is open or shorted.)• A/F sensor 1 heater
P0032	Air fuel ratio (A/F) sensor 1 heater (bank 1) control circuit high	The current amperage in the A/F sensor 1 heater circuit is out of the normal range. (An excessively high voltage signal is sent to ECM through the A/F sensor 1 heater.)	<ul style="list-style-type: none">• Harness or connectors (The A/F sensor 1 heater circuit is shorted.)• A/F sensor 1 heater
P0051	Air fuel ratio (A/F) sensor 1 heater (bank 2) control circuit low	The current amperage in the A/F sensor 1 heater circuit is out of the normal range. (An excessively low voltage signal is sent to ECM through the A/F sensor 1 heater.)	<ul style="list-style-type: none">• Harness or connectors (The A/F sensor 1 heater circuit is open or shorted.)• A/F sensor 1 heater
P0052	Air fuel ratio (A/F) sensor 1 heater (bank 2) control circuit high	The current amperage in the A/F sensor 1 heater circuit is out of the normal range. (An excessively high voltage signal is sent to ECM through the A/F sensor 1 heater.)	<ul style="list-style-type: none">• Harness or connectors (The A/F sensor 1 heater circuit is shorted.)• A/F sensor 1 heater

DTC CONFIRMATION PROCEDURE

1. PRECONDITIONING

If DTC Confirmation Procedure has been previously conducted, always perform the following before conducting the next test.

1. Turn ignition switch OFF and wait at least 10 seconds.
2. Turn ignition switch ON.
3. Turn ignition switch OFF and wait at least 10 seconds.

TESTING CONDITION:

Before performing the following procedure, confirm that battery voltage is more than 11 V at idle.

>> GO TO 2.

2. PERFORM DTC CONFIRMATION PROCEDURE

1. Start engine and let it idle for at least 10 seconds.
2. Check 1st trip DTC.

Is 1st trip DTC detected?

YES >> Go to [EC-145, "Diagnosis Procedure"](#).

NG >> INSPECTION END

Diagnosis Procedure

INFOID:000000003387944

1. CHECK GROUND CONNECTION

P0031, P0032, P0051, P0052 A/F SENSOR 1 HEATER

[VQ35DE]

< COMPONENT DIAGNOSIS >

1. Turn ignition switch OFF.
2. Check ground connection E38. Refer to Ground Inspection in [GI-40, "Intermittent Incident"](#).

Is the inspection result normal?

- YES >> GO TO 2.
NO >> Repair or replace ground connection.

2.CHECK AIR FUEL RATIO (A/F) SENSOR 1 POWER SUPPLY CIRCUIT

1. Disconnect air fuel ratio (A/F) sensor 1 harness connector.
2. Turn ignition switch ON.
3. Check the voltage between A/F sensor 1 harness connector and ground.

DTC	A/F sensor 1			Ground	Voltage
	Bank	Connector	Terminal		
P0031, P0032	1	F27	4	Ground	Battery voltage
P0051, P0052	2	F64	4		

Is the inspection result normal?

- YES >> GO TO 4.
NO >> GO TO 3.

3.DETECT MALFUNCTIONING PART

Check the following.

- IPDM E/R harness connector F12
- 15 A fuse (No. 46)
- Harness for open or short between A/F sensor 1 and fuse

>> Repair or replace harness or connectors.

4.CHECK A/F SENSOR 1 HEATER OUTPUT SIGNAL CIRCUIT

1. Turn ignition switch OFF.
2. Disconnect ECM harness connector.
3. Check harness continuity between A/F sensor 1 harness connector and ECM harness connector.

DTC	A/F sensor 1			ECM		Continuity
	Bank	Connector	Terminal	Connector	Terminal	
P0031, P0032	1	F27	3	F7	4	Existed
P0051, P0052	2	F64	3		8	

4. Also check harness for short to ground and short to power.

Is the inspection result normal?

- YES >> GO TO 5.
NO >> Repair open circuit, short to ground or short to power in harness or connectors.

5.CHECK A/F SENSOR 1 HEATER

Refer to [EC-147, "Component Inspection"](#).

Is the inspection result normal?

- YES >> GO TO 7.
NO >> GO TO 6.

6.REPLACE AIR FUEL RATIO (A/F) SENSOR 1

Replace malfunctioning air fuel ratio (A/F) sensor 1.

CAUTION:

- Discard any A/F sensor which has been dropped from a height of more than 0.5 m (19.7 in) onto a hard surface such as a concrete floor; use a new one.
- Before installing new A/F sensor, clean exhaust system threads using Oxygen Sensor Thread Cleaner [commercial service tool (J-43897-18 or J-43897-12)] and approved anti-seize lubricant (commercial service tool).

P0031, P0032, P0051, P0052 A/F SENSOR 1 HEATER

< COMPONENT DIAGNOSIS >

[VQ35DE]

>> INSPECTION END

7. CHECK INTERMITTENT INCIDENT

Perform [GI-40. "Intermittent Incident"](#).

>> INSPECTION END

Component Inspection

INFOID:000000003387945

1. CHECK AIR FUEL RATIO (A/F) SENSOR 1

Check resistance between A/F sensor terminals as per the following.

Terminal No.	Resistance
3 and 4	1.8 - 2.44 Ω [at 25°C (77°F)]
3 and 1, 2	$\infty \Omega$
4 and 1, 2	(Continuity should not exist)

Is the inspection result normal?

YES >> INSPECTION END

NO >> GO TO 2.

2. REPLACE AIR FUEL RATIO (A/F) SENSOR 1

Replace malfunctioning air fuel ratio (A/F) sensor 1.

CAUTION:

- Discard any (A/F) sensor which has been dropped from a height of more than 0.5 m (19.7 in) onto a hard surface such as a concrete floor; use a new one.
- Before installing new (A/F) sensor, clean exhaust system threads using Heated Oxygen Sensor Thread Cleaner [commercial service tool (J-43897-18 or J-43897-12)] and approved anti-seize lubricant (commercial service tool).

>> INSPECTION END

P0037, P0038, P0057, P0058 HO2S2 HEATER

< COMPONENT DIAGNOSIS >

[VQ35DE]

P0037, P0038, P0057, P0058 HO2S2 HEATER

Description

INFOID:000000003387946

SYSTEM DESCRIPTION

Sensor	Input signal to ECM	ECM function	Actuator
Camshaft position sensor (PHASE) Crankshaft position sensor (POS)	Engine speed	Heated oxygen sensor 2 heater control	Heated oxygen sensor 2 heater
Engine coolant temperature sensor	Engine coolant temperature		
Mass air flow sensor	Amount of intake air		

The ECM performs ON/OFF control of the heated oxygen sensor 2 heater corresponding to the engine speed, amount of intake air and engine coolant temperature.

OPERATION

Engine speed	Heated oxygen sensor 2 heater
Above 3,600 rpm	OFF
Below 3,600 rpm after the following conditions are met. <ul style="list-style-type: none">• Engine: After warming up• Keeping the engine speed between 3,500 and 4,000 rpm for 1 minute and at idle for 1 minute under no load	ON

DTC Logic

INFOID:000000003387947

DTC DETECTION LOGIC

DTC No.	Trouble diagnosis name	DTC detecting condition	Possible cause
P0037	Heated oxygen sensor 2 heater (bank 1) control circuit low	The current amperage in the heated oxygen sensor 2 heater circuit is out of the normal range. (An excessively low voltage signal is sent to ECM through the heated oxygen sensor 2 heater.)	<ul style="list-style-type: none">• Harness or connectors (The heated oxygen sensor 2 heater circuit is open or shorted.)• Heated oxygen sensor 2 heater
P0038	Heated oxygen sensor 2 heater (bank 1) control circuit high	The current amperage in the heated oxygen sensor 2 heater circuit is out of the normal range. (An excessively high voltage signal is sent to ECM through the heated oxygen sensor 2 heater.)	<ul style="list-style-type: none">• Harness or connectors (The heated oxygen sensor 2 heater circuit is shorted.)• Heated oxygen sensor 2 heater
P0057	Heated oxygen sensor 2 heater (bank 2) control circuit low	The current amperage in the heated oxygen sensor 2 heater circuit is out of the normal range. (An excessively low voltage signal is sent to ECM through the heated oxygen sensor 2 heater.)	<ul style="list-style-type: none">• Harness or connectors (The heated oxygen sensor 2 heater circuit is open or shorted.)• Heated oxygen sensor 2 heater
P0058	Heated oxygen sensor 2 heater (bank 2) control circuit high	The current amperage in the heated oxygen sensor 2 heater circuit is out of the normal range. (An excessively high voltage signal is sent to ECM through the heated oxygen sensor 2 heater.)	<ul style="list-style-type: none">• Harness or connectors (The heated oxygen sensor 2 heater circuit is shorted.)• Heated oxygen sensor 2 heater

DTC CONFIRMATION PROCEDURE

1. PRECONDITIONING

If DTC Confirmation Procedure has been previously conducted, always perform the following before conducting the next test.

1. Turn ignition switch OFF and wait at least 10 seconds.
2. Turn ignition switch ON.
3. Turn ignition switch OFF and wait at least 10 seconds.

TESTING CONDITION:

Before performing the following procedure, confirm that battery voltage is between 10.5 V and 16 V at idle.

>> GO TO 2.

P0037, P0038, P0057, P0058 HO2S2 HEATER

< COMPONENT DIAGNOSIS >

[VQ35DE]

2. PERFORM DTC CONFIRMATION PROCEDURE

1. Start engine and warm it up to the normal operating temperature.
2. Turn ignition switch OFF and wait at least 10 seconds.
3. Turn ignition switch ON.
4. Turn ignition switch OFF and wait at least 10 seconds.
5. Start engine and keep the engine speed between 3,500 and 4,000 rpm for at least 1 minute under no load.
6. Let engine idle for 1 minute.
7. Check 1st trip DTC.

Is 1st trip DTC detected?

- YES >> Go to [EC-149. "Diagnosis Procedure"](#).
NO >> INSPECTION END

Diagnosis Procedure

INFOID:000000003387948

1. CHECK GROUND CONNECTION

1. Turn ignition switch OFF.
2. Check ground connection E38. Refer to Ground Inspection in [GI-43. "Circuit Inspection"](#).

Is the inspection result normal?

- YES >> GO TO 2.
NO >> Repair or replace ground connection.

2. CHECK HO2S2 POWER SUPPLY CIRCUIT

1. Disconnect heated oxygen sensor 2 (HO2S2) harness connector.
2. Turn ignition switch ON.
3. Check the voltage between HO2S2 harness connector and ground.

DTC	HO2S2			Ground	Voltage
	Bank	Connector	Terminal		
P0037, P0038	1	F70	2	Ground	Battery voltage
P0057, P0058	2	F71	2		

Is the inspection result normal?

- YES >> GO TO 4.
NO >> GO TO 3.

3. DETECT MALFUNCTIONING PART

Check the following.

- IPDM E/R connector F8
- 15 A fuse (No. 46)
- Harness for open or short between heated oxygen sensor 2 and fuse

>> Repair open circuit, short to ground or short to power in harness or connectors.

4. CHECK HO2S2 OUTPUT SIGNAL CIRCUIT FOR OPEN AND SHORT

1. Turn ignition switch OFF.
2. Disconnect ECM harness connector.
3. Check the continuity between HO2S2 harness connector and ECM harness connector.

DTC	HO2S2			ECM		Continuity
	Bank	Connector	Terminal	Connector	Terminal	
P0037, P0038	1	F70	3	F7	13	Existed
P0057, P0058	2	F71	3		17	

4. Also check harness for short to ground and short to power.

Is the inspection result normal?

- YES >> GO TO 5.

P0037, P0038, P0057, P0058 HO2S2 HEATER

[VQ35DE]

< COMPONENT DIAGNOSIS >

NO >> Repair open circuit, short to ground or short to power in harness or connectors.

5. CHECK HEATED OXYGEN SENSOR 2 HEATER

Refer to [EC-150, "Component Inspection"](#).

Is the inspection result normal?

YES >> GO TO 7.

NO >> GO TO 6.

6. REPLACE HEATED OXYGEN SENSOR 2

Replace malfunctioning heated oxygen sensor 2.

CAUTION:

- Discard any heated oxygen sensor which has been dropped from a height of more than 0.5 m (19.7 in) onto a hard surface such as a concrete floor; use a new one.
- Before installing new oxygen sensor, clean exhaust system threads using Oxygen Sensor Thread Cleaner [commercial service tool (J-43897-18 or J-43897-12)] and approved anti-seize lubricant (commercial service tool).

>> INSPECTION END

7. CHECK INTERMITTENT INCIDENT

Refer to [GI-40, "Intermittent Incident"](#).

>> INSPECTION END

Component Inspection

INFOID:000000003387949

1. CHECK HEATED OXYGEN SENSOR 2 HEATER

Check resistance between HO2S2 terminals as per the following.

Terminal No.	Resistance
2 and 3	3.4 - 4.4 Ω [at 25°C (77°F)]
1 and 2, 3, 4	$\infty \Omega$
4 and 1, 2, 3	(Continuity should not exist)

Is the inspection result normal?

YES >> INSPECTION END

NO >> GO TO 2.

2. REPLACE HEATED OXYGEN SENSOR 2

Replace malfunctioning heated oxygen sensor 2.

CAUTION:

- Discard any heated oxygen sensor which has been dropped from a height of more than 0.5 m (19.7 in) onto a hard surface such as a concrete floor; use a new one.
- Before installing new oxygen sensor, clean exhaust system threads using Oxygen Sensor Thread Cleaner [commercial service tool (J-43897-18 or J-43897-12)] and approved anti-seize lubricant (commercial service tool).

>> INSPECTION END

P0075, P0081 IVT CONTROL SOLENOID VALVE

< COMPONENT DIAGNOSIS >

[VQ35DE]

P0075, P0081 IVT CONTROL SOLENOID VALVE

Description

INFOID:000000003387950

Intake valve timing control solenoid valve is activated by ON/OFF pulse duty (ratio) signals from the ECM.
 The intake valve timing control solenoid valve changes the oil amount and direction of flow through intake valve timing control unit or stops oil flow.
 The longer pulse width advances valve timing.
 The shorter pulse width retards valve timing.
 When ON and OFF pulse widths become equal, the solenoid valve stops oil pressure flow to fix the intake valve angle at the control position.

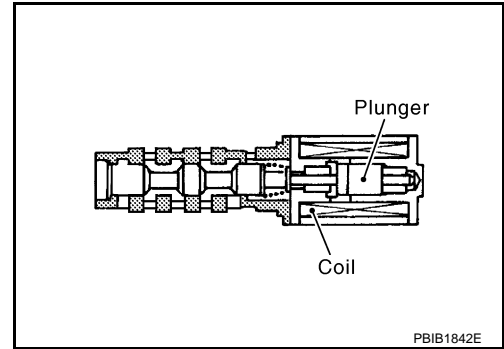

DTC Logic

INFOID:000000003387951

DTC DETECTION LOGIC

DTC No.	Trouble diagnosis name	DTC detecting condition	Possible cause
P0075	Intake valve timing control solenoid valve (bank 1) circuit	An improper voltage is sent to the ECM through intake valve timing control solenoid valve.	<ul style="list-style-type: none"> • Harness or connectors (Intake valve timing control solenoid valve circuit is open or shorted.) • Intake valve timing control solenoid valve
P0081	Intake valve timing control solenoid valve (bank 2) circuit		

DTC CONFIRMATION PROCEDURE

1. PRECONDITIONING

If DTC Confirmation Procedure has been previously conducted, always perform the following before conducting the next test.

1. Turn ignition switch OFF and wait at least 10 seconds.
2. Turn ignition switch ON.
3. Turn ignition switch OFF and wait at least 10 seconds.

>> GO TO 2.

2. PERFORM DTC CONFIRMATION PROCEDURE

1. Start engine and let it idle for 5 seconds.
2. Check 1st trip DTC.

Is 1st trip DTC detected?

- YES >> Go to [EC-151. "Diagnosis Procedure"](#).
 NO >> INSPECTION END

Diagnosis Procedure

INFOID:000000003387952

1. CHECK INTAKE VALVE TIMING CONTROL SOLENOID VALVE POWER SUPPLY CIRCUIT

1. Turn ignition switch OFF.
2. Disconnect intake valve timing (IVT) control solenoid valve harness connector.
3. Turn ignition switch ON.
4. Check the voltage between intake valve timing control solenoid valve harness connector and ground with CONSULT-III or tester.

DTC	IVT control solenoid valve			Ground	Voltage
	Bank	Connector	Terminal		
P0075	1	F81	2	Ground	Battery voltage
P0081	2	F82	2		

P0075, P0081 IVT CONTROL SOLENOID VALVE

[VQ35DE]

< COMPONENT DIAGNOSIS >

Is the inspection result normal?

YES >> GO TO 2.

NO >> Repair open circuit, short to ground or short to power in harness or connectors.

2.CHECK INTAKE VALVE TIMING CONTROL SOLENOID VALVE OUTPUT SIGNAL CIRCUIT FOR OPEN AND SHORT

1. Turn ignition switch OFF.
2. Disconnect ECM harness connector.
3. Check the continuity between intake valve timing control solenoid valve harness connector and ECM harness connector.

DTC	IVT control solenoid valve			ECM		Continuity
	Bank	Connector	Terminal	Connector	Terminal	
P0075	1	F81	1	F8	78	Existed
P0081	2	F82	1		75	

4. Also check harness for short to ground and short to power.

Is the inspection result normal?

YES >> GO TO 3.

NO >> Repair open circuit, short to ground or short to power in harness or connectors.

3.CHECK INTAKE VALVE TIMING CONTROL SOLENOID VALVE

Refer to [EC-152, "Component Inspection"](#).

Is the inspection result normal?

YES >> GO TO 4.

NO >> Replace malfunctioning intake valve timing control solenoid valve.

4.CHECK INTERMITTENT INCIDENT

Refer to [GI-40, "Intermittent Incident"](#).

>> INSPECTION END

Component Inspection

INFOID:000000003591557

1.CHECK INTAKE VALVE TIMING CONTROL SOLENOID VALVE-I

1. Disconnect intake valve timing control solenoid valve harness connector.
2. Check resistance between intake valve timing control solenoid valve terminals as per the following.

Terminals	Resistance
1 and 2	7.0 - 7.5 Ω [at 20°C (68°F)]
1 or 2 and ground	$\infty\Omega$ (Continuity should not exist)

Is the inspection result normal?

YES >> GO TO 2.

NO >> Replace malfunctioning intake valve timing control solenoid valve.

2.CHECK INTAKE VALVE TIMING CONTROL SOLENOID VALVE-II

1. Remove intake valve timing control solenoid valve.

P0075, P0081 IVT CONTROL SOLENOID VALVE

[VQ35DE]

< COMPONENT DIAGNOSIS >

2. Provide 12 V DC between intake valve timing control solenoid valve terminals 1 and 2, and then interrupt it. Check that the plunger moves as shown in the figure.

CAUTION:

Never apply 12 V DC continuously for 5 seconds or more. Doing so may result in damage to the coil in intake valve timing control solenoid valve.

NOTE:

Always replace O-ring when intake valve timing control solenoid valve is removed.

Is the inspection result normal?

YES >> INSPECTION END

NO >> Replace malfunctioning intake valve timing control solenoid valve.

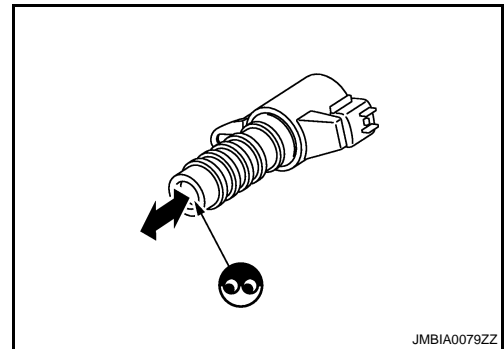

A

EC

C

D

E

F

G

H

I

J

K

L

M

N

O

P

P0101 MAF SENSOR

Description

INFOID:000000003387954

The mass air flow sensor (1) is placed in the stream of intake air. It measures the intake flow rate by measuring a part of the entire intake flow. The mass air flow sensor controls the temperature of the hot wire to a certain amount. The heat generated by the hot wire is reduced as the intake air flows around it. The greater air flow, the greater the heat loss. Therefore, the electric current supplied to hot wire is changed to maintain the temperature of the hot wire as air flow increases. The ECM detects the air flow by means of this current change.

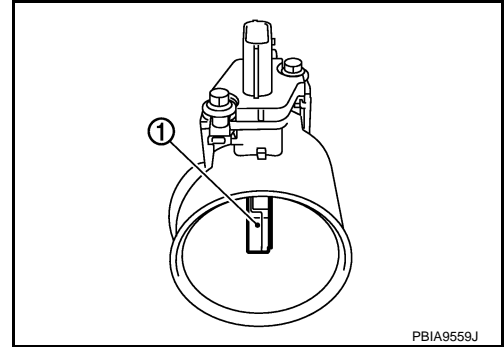

DTC Logic

INFOID:000000003387955

DTC DETECTION LOGIC

DTC No.	Trouble diagnosis name	DTC detecting condition		Possible cause
P0101	Mass air flow sensor circuit range/performance	A)	A high voltage from the sensor is sent to ECM under light load driving condition.	<ul style="list-style-type: none"> • Harness or connectors (The sensor circuit is open or shorted.) • Mass air flow sensor • EVAP control system pressure sensor
		B)	A low voltage from the sensor is sent to ECM under heavy load driving condition.	<ul style="list-style-type: none"> • Harness or connectors (The sensor circuit is open or shorted.) • Intake air leakage • Mass air flow sensor • EVAP control system pressure sensor • Intake air temperature sensor

DTC CONFIRMATION PROCEDURE

NOTE:

Check vehicle specifications and VIN, then select the procedure to be performed. (Refer to the table below.)

Vehicle specification	Vehicle serial number	TYPE
2WD	Up to JN8AZ18U*9W100000	A
	From JN8AZ18U*9W100001	B
	Up to JN8AZ18U*9W710000	A
	From JN8AZ18U*9W710001	B
4WD	Up to JN8AZ18W*9W200000	A
	From JN8AZ18W*9W200001	B
	Up to JN8AZ18W*9W810000	A
	From JN8AZ18W*9W810001	B

TYPE A

1. PRECONDITIONING

If DTC Confirmation Procedure has been previously conducted, always perform the following before conducting the next test.

1. Turn ignition switch OFF and wait at least 10 seconds.
2. Turn ignition switch ON.
3. Turn ignition switch OFF and wait at least 10 seconds.

>> GO TO 2.

2. PERFORM DTC CONFIRMATION PROCEDURE FOR MALFUNCTION A

1. Start engine and warm it up to normal operating temperature.
2. Run engine for at least 10 seconds at idle speed.
3. Check 1st trip DTC.

Is 1st trip DTC detected?

- YES >> Go to [EC-157, "Diagnosis Procedure"](#).
- NO-1 >> With CONSULT-III: GO TO 3.
- NO-2 >> Without CONSULT-III: GO TO 5.

3. CHECK MASS AIR FLOW SENSOR FUNCTION

1. Turn ignition switch ON.
2. Start engine and warm it up to normal operating temperature.
If engine cannot be started, go to [EC-157, "Diagnosis Procedure"](#).
3. Select "MAS A/F SE-B1" in "DATA MONITOR" mode with CONSULT-III.
4. Check the voltage of "MAS A/F SE-B1".
5. Increases engine speed to about 4,000 rpm.
6. Monitor the linear voltage rise in response to engine speed increases.

Is the inspection result normal?

- YES >> GO TO 4.
- NO >> Go to [EC-157, "Diagnosis Procedure"](#).

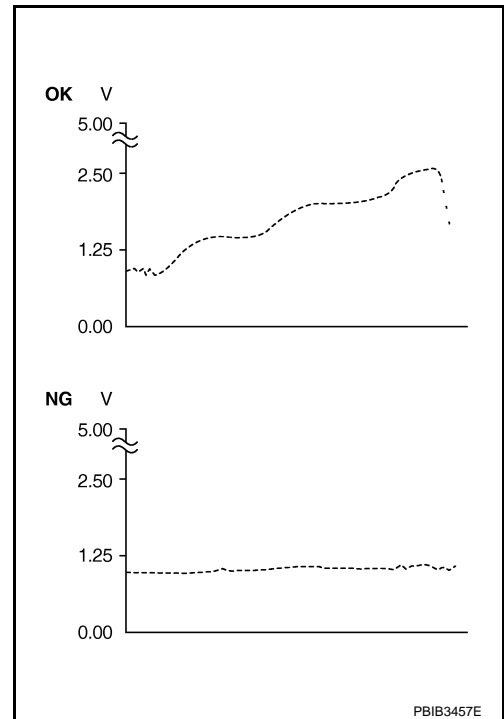

4. PERFORM DTC CONFIRMATION PROCEDURE FOR MALFUNCTION B

1. Maintain the following conditions for at least 5 consecutive seconds.

ENG SPEED	More than 2,000 rpm
TP SEN 1-B1	More than 3 V
TP SEN 2-B1	More than 3 V
Selector lever	Suitable position
Driving location	Driving vehicle uphill (Increased engine load) will help maintain the driving conditions required for this test.

CAUTION:

Always drive vehicle at a safe speed.

2. Check 1st trip DTC.

Is 1st trip DTC detected?

- YES >> Go to [EC-157, "Diagnosis Procedure"](#).
- NO >> INSPECTION END

5. PERFORM COMPONENT FUNCTION CHECK FOR MALFUNCTION B

P0101 MAF SENSOR

[VQ35DE]

< COMPONENT DIAGNOSIS >

Perform component function check. Refer to [EC-157. "Component Function Check"](#).

NOTE:

Use component function check to check the overall function of the mass air flow sensor circuit. During this check, a 1st trip DTC might not be confirmed.

Is the inspection result normal?

- YES >> INSPECTION END
- NO >> Go to [EC-157. "Diagnosis Procedure"](#).

TYPE B

1. PRECONDITIONING

If DTC Confirmation Procedure has been previously conducted, always perform the following before conducting the next test.

1. Turn ignition switch OFF and wait at least 10 seconds.
2. Turn ignition switch ON.
3. Turn ignition switch OFF and wait at least 10 seconds.

>> GO TO 2.

2. PERFORM DTC CONFIRMATION PROCEDURE FOR MALFUNCTION A

1. Start engine and warm it up to normal operating temperature.
2. Run engine for at least 10 seconds at idle speed.
3. Check 1st trip DTC.

Is 1st trip DTC detected?

- YES >> Go to [EC-157. "Diagnosis Procedure"](#).
- NO-1 >> With CONSULT-III: GO TO 3.
- NO-2 >> Without CONSULT-III: GO TO 5.

3. CHECK MASS AIR FLOW SENSOR FUNCTION

1. Turn ignition switch ON.
2. Start engine and warm it up to normal operating temperature.
If engine cannot be started, go to [EC-157. "Diagnosis Procedure"](#).
3. Select "MAS A/F SE-B1" in "DATA MONITOR" mode with CONSULT-III.
4. Check the voltage of "MAS A/F SE-B1".
5. Increase engine speed to about 4,000 rpm.
6. Monitor the linear voltage rise in response to engine speed increases.

Is the inspection result normal?

- YES >> GO TO 4.
- NO >> Go to [EC-157. "Diagnosis Procedure"](#).

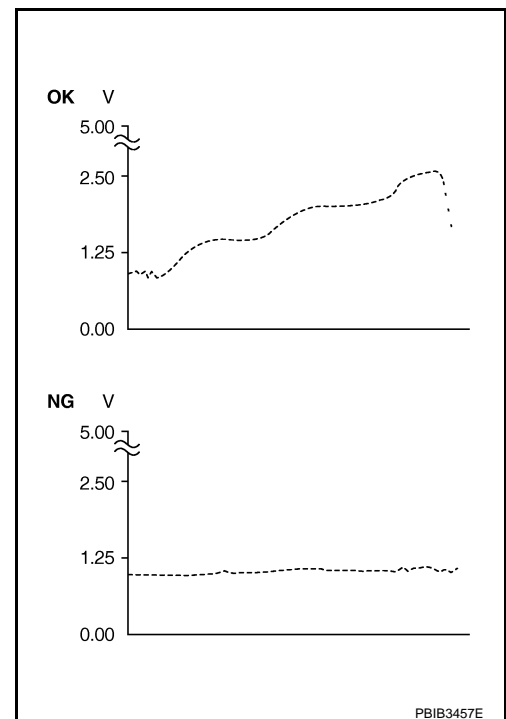

4. PERFORM DTC CONFIRMATION PROCEDURE FOR MALFUNCTION B

1. Maintain the following conditions for at least 10 consecutive seconds.

P0101 MAF SENSOR

< COMPONENT DIAGNOSIS >

[VQ35DE]

ENG SPEED	More than 2,000 rpm
TP SEN 1-B1	More than 1.5 V
TP SEN 2-B1	More than 1.5 V
Selector lever	Suitable position
Driving location	Driving vehicle uphill (Increased engine load) will help maintain the driving conditions required for this test.

CAUTION:

Always drive vehicle at a safe speed.

2. Check 1st trip DTC.

Is 1st trip DTC detected?

- YES >> Go to [EC-157, "Diagnosis Procedure"](#).
- NO >> INSPECTION END

5.PERFORM COMPONENT FUNCTION CHECK FOR MALFUNCTION B

Perform component function check. Refer to [EC-157, "Component Function Check"](#).

NOTE:

Use component function check to check the overall function of the mass air flow sensor circuit. During this check, a 1st trip DTC might not be confirmed.

Is the inspection result normal?

- YES >> INSPECTION END
- NO >> Go to [EC-157, "Diagnosis Procedure"](#).

Component Function Check

INFOID:000000003387956

1.PERFORM COMPONENT FUNCTION CHECK FOR MALFUNCTION B

 **With GST**

1. Start engine and warm it up to normal operating temperature.
2. Select Service \$01 with GST.
3. Check the mass air flow sensor signal with Service \$01.
4. Check for linear mass air flow sensor signal value rise in response to increases to about 4,000 rpm in engine speed.

Is the inspection result normal?

- YES >> INSPECTION END
- NO >> Go to [EC-157, "Diagnosis Procedure"](#).

CALC LOAD	20%
COOLANT TEMP	95°C
SHORT FT #1	2%
LONG FT #1	0%
SHORT FT #2	4%
LONG FT #2	0%
ENGINE SPD	2637RPM
VEHICLE SPD	0MPH
IGN ADVANCE	41.0°
INTAKE AIR	41°C
MAF	14.1gm/sec
THROTTLE POS	3%

SEF534P

Diagnosis Procedure

INFOID:000000003387957

1.INSPECTION START

Confirm the detected malfunction (A or B). Refer to [EC-154, "DTC Logic"](#).

Which malfunction is detected?

- A >> GO TO 3.
- B >> GO TO 2.

2.CHECK INTAKE SYSTEM

Check the following for connection.

- Air duct
- Vacuum hoses
- Intake air passage between air duct and intake manifold

Is the inspection result normal?

- YES >> GO TO 3.

P0101 MAF SENSOR

[VQ35DE]

< COMPONENT DIAGNOSIS >

NO >> Reconnect the parts.

3.CHECK GROUND CONNECTION

1. Turn ignition switch OFF.
2. Check ground connection E38. Refer to Ground Inspection in [GI-43. "Circuit Inspection"](#).

Is the inspection result normal?

- YES >> GO TO 4.
NO >> Repair or replace ground connection.

4.CHECK MAF SENSOR POWER SUPPLY CIRCUIT

1. Disconnect mass air flow (MAF) sensor harness connector.
2. Turn ignition switch ON.
3. Check the voltage between MAF sensor harness connector and ground.

MAF sensor		Ground	Voltage
Connector	Terminal		
F4	5	Ground	Battery voltage

Is the inspection result normal?

- YES >> GO TO 6.
NO >> GO TO 5.

5.DETECT MALFUNCTIONING PART

Check the following.

- Harness connectors E7, F121
- Harness for open or short between mass air flow sensor and ECM
- Harness for open or short between mass air flow sensor and IPDM E/R

>> Repair open circuit, short to ground or short to power in harness or connectors.

6.CHECK MAF SENSOR GROUND CIRCUIT FOR OPEN AND SHORT

1. Turn ignition switch OFF.
2. Disconnect ECM harness connector.
3. Check the continuity between MAF sensor harness connector and ECM harness connector.

MAF sensor		ECM		Continuity
Connector	Terminal	Connector	Terminal	
F4	4	F8	56	Existed

4. Also check harness for short to ground and short to power.

Is the inspection result normal?

- YES >> GO TO 7.
NO >> Repair open circuit, short to ground or short to power in harness or connectors.

7.CHECK MAF SENSOR INPUT SIGNAL CIRCUIT FOR OPEN AND SHORT

1. Check the continuity between MAF sensor harness connector and ECM harness connector.

MAF sensor		ECM		Continuity
Connector	Terminal	Connector	Terminal	
F4	3	F8	58	Existed

2. Also check harness for short to ground and short to power.

Is the inspection result normal?

- YES >> GO TO 8.
NO >> Repair open circuit, short to ground or short to power in harness or connectors.

8.CHECK INTAKE AIR TEMPERATURE SENSOR

P0101 MAF SENSOR

[VQ35DE]

< COMPONENT DIAGNOSIS >

Refer to [EC-168, "Component Inspection"](#).

Is the inspection result normal?

YES >> GO TO 9.

NO >> Replace mass air flow sensor (with intake air temperature sensor).

9. CHECK EVAP CONTROL SYSTEM PRESSURE SENSOR

Refer to [EC-302, "Component Inspection"](#).

Is the inspection result normal?

YES >> GO TO 10.

NO >> Replace EVAP control system pressure sensor.

10. CHECK MASS AIR FLOW SENSOR

Refer to [EC-159, "Component Inspection"](#).

Is the inspection result normal?

YES >> GO TO 11.

NO >> Replace mass air flow sensor.

11. CHECK INTERMITTENT INCIDENT

Refer to [GI-40, "Intermittent Incident"](#).

>> INSPECTION END

Component Inspection

INFOID:000000003387958

1. CHECK MASS AIR FLOW SENSOR-I

With CONSULT-III

1. Reconnect all harness connectors disconnected.
2. Start engine and warm it up to normal operating temperature.
3. Connect CONSULT-III and select "DATA MONITOR" mode.
4. Select "MAS A/F SE-B1" and check indication under the following conditions.

Monitor item	Condition	MAS A/F SE-B1 (V)
MAS A/F SE-B1	Ignition switch ON (Engine stopped.)	Approx. 0.4
	Idle (Engine is warmed-up to normal operating temperature.)	0.9 - 1.2
	2,500 rpm (Engine is warmed-up to normal operating temperature.)	1.6 - 1.9
	Idle to approximately 4,000 rpm	0.9 - 1.2 to Approx. 2.4*

*: Check for linear voltage rise in response to engine being increased to approximately 4,000 rpm.

Without CONSULT-III

1. Reconnect all harness connectors disconnected.
2. Start engine and warm it up to normal operating temperature.
3. Check the voltage between ECM harness connector terminals under the following conditions.

Connector	ECM		Condition	Voltage (V)
	+	-		
	Terminal	Terminal		
F8	58 (MAF sensor signal)	56 (Sensor ground)	Ignition switch ON (Engine stopped.)	Approx. 0.4
			Idle (Engine is warmed-up to normal operating temperature.)	0.9 - 1.2
			2,500 rpm (Engine is warmed-up to normal operating temperature.)	1.6 - 1.9
			Idle to approximately 4,000 rpm	0.9 - 1.2 to Approx. 2.4*

*: Check for linear voltage rise in response to engine being increased to approximately 4,000 rpm.

Is the inspection result normal?

YES >> INSPECTION END

P0101 MAF SENSOR

[VQ35DE]

< COMPONENT DIAGNOSIS >

NO >> GO TO 2.

2. CHECK FOR THE CAUSE OF UNEVEN AIR FLOW THROUGH MASS AIR FLOW SENSOR

Check for the cause of uneven air flow through mass air flow sensor. Refer to the following.

- Crushed air ducts
- Malfunctioning seal of air cleaner element
- Uneven dirt of air cleaner element
- Improper specification of intake air system parts

Is the inspection result normal?

YES >> GO TO 4.

NO >> GO TO 3.

3. CHECK MASS AIR FLOW SENSOR-II

With CONSULT-III

1. Repair or replace malfunctioning part.
2. Start engine and warm it up to normal operating temperature.
3. Connect CONSULT-III and select "DATA MONITOR" mode.
4. Select "MAS A/F SE-B1" and check indication under the following conditions.

Monitor item	Condition	MAS A/F SE-B1 (V)
MAS A/F SE-B1	Ignition switch ON (Engine stopped.)	Approx. 0.4
	Idle (Engine is warmed-up to normal operating temperature.)	0.9 - 1.2
	2,500 rpm (Engine is warmed-up to normal operating temperature.)	1.6 - 1.9
	Idle to approximately 4,000 rpm	0.9 - 1.2 to Approx. 2.4*

*: Check for linear voltage rise in response to engine being increased to approximately 4,000 rpm.

Without CONSULT-III

1. Repair or replace malfunctioning part.
2. Start engine and warm it up to normal operating temperature.
3. Check the voltage between ECM harness connector terminals under the following conditions.

ECM			Condition	Voltage (V)
Connector	+	-		
	Terminal	Terminal		
F8	58 (MAF sensor signal)	56 (Sensor ground)	Ignition switch ON (Engine stopped.)	Approx. 0.4
			Idle (Engine is warmed-up to normal operating temperature.)	0.9 - 1.2
			2,500 rpm (Engine is warmed-up to normal operating temperature.)	1.6 - 1.9
			Idle to approximately 4,000 rpm	0.9 - 1.2 to Approx. 2.4*

*: Check for linear voltage rise in response to engine being increased to approximately 4,000 rpm.

Is the inspection result normal?

YES >> INSPECTION END

NO >> GO TO 4.

4. CHECK MASS AIR FLOW SENSOR-III

With CONSULT-III

1. Turn ignition switch OFF.
2. Disconnect mass air flow sensor harness connector and reconnect it again.
3. Start engine and warm it up to normal operating temperature.
4. Connect CONSULT-III and select "DATA MONITOR" mode.
5. Select "MAS A/F SE-B1" and check indication under the following conditions.

P0101 MAF SENSOR

< COMPONENT DIAGNOSIS >

[VQ35DE]

Monitor item	Condition	MAS A/F SE-B1 (V)
MAS A/F SE-B1	Ignition switch ON (Engine stopped.)	Approx. 0.4
	Idle (Engine is warmed-up to normal operating temperature.)	0.9 - 1.2
	2,500 rpm (Engine is warmed-up to normal operating temperature.)	1.6 - 1.9
	Idle to approximately 4,000 rpm	0.9 - 1.2 to Approx. 2.4*

*: Check for linear voltage rise in response to engine being increased to approximately 4,000 rpm.

⊗ Without CONSULT-III

1. Turn ignition switch OFF.
2. Disconnect mass air flow sensor harness connector and reconnect it again.
3. Start engine and warm it up to normal operating temperature.
4. Check the voltage between ECM harness connector terminals under the following conditions.

Connector	ECM		Condition	Voltage (V)
	+	-		
	Terminal	Terminal		
F8	58 (MAF sensor signal)	56 (Sensor ground)	Ignition switch ON (Engine stopped.)	Approx. 0.4
			Idle (Engine is warmed-up to normal operating temperature.)	0.9 - 1.2
			2,500 rpm (Engine is warmed-up to normal operating temperature.)	1.6 - 1.9
			Idle to approximately 4,000 rpm	0.9 - 1.2 to Approx. 2.4*

*: Check for linear voltage rise in response to engine being increased to approximately 4,000 rpm.

Is the inspection result normal?

- YES >> INSPECTION END
 NO >> Clean or replace mass air flow sensor.

A
EC
C
D
E
F
G
H
I
J
K
L
M
N
O
P

P0102, P0103 MAF SENSOR

Description

INFOID:000000003591558

The mass air flow sensor (1) is placed in the stream of intake air. It measures the intake flow rate by measuring a part of the entire intake flow. The mass air flow sensor controls the temperature of the hot wire to a certain amount. The heat generated by the hot wire is reduced as the intake air flows around it. The greater air flow, the greater the heat loss. Therefore, the electric current supplied to hot wire is changed to maintain the temperature of the hot wire as air flow increases. The ECM detects the air flow by means of this current change.

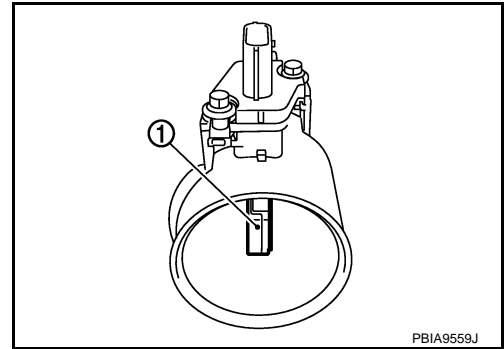

DTC Logic

INFOID:000000003387960

DTC DETECTION LOGIC

DTC No.	Trouble diagnosis name	DTC detecting condition	Possible cause
P0102	Mass air flow sensor circuit low input	An excessively low voltage from the sensor is sent to ECM.	<ul style="list-style-type: none"> • Harness or connectors (The sensor circuit is open or shorted.) • Intake air leakage • Mass air flow sensor
P0103	Mass air flow sensor circuit high input	An excessively high voltage from the sensor is sent to ECM.	<ul style="list-style-type: none"> • Harness or connectors (The sensor circuit is open or shorted.) • Mass air flow sensor

DTC CONFIRMATION PROCEDURE

1. PRECONDITIONING

If DTC Confirmation Procedure has been previously conducted, always perform the following before conducting the next test.

1. Turn ignition switch OFF and wait at least 10 seconds.
2. Turn ignition switch ON.
3. Turn ignition switch OFF and wait at least 10 seconds.

Which DTC is detected?

- P0102 >> GO TO 2.
- P0103 >> GO TO 3.

2. PERFORM DTC CONFIRMATION PROCEDURE FOR DTC P0102

1. Start engine and wait at least 5 seconds.
2. Check DTC.

Is DTC detected?

- YES >> Go to [EC-163, "Diagnosis Procedure"](#).
- NO >> INSPECTION END

3. PERFORM DTC CONFIRMATION PROCEDURE FOR DTC P0103-I

1. Turn ignition switch ON and wait at least 5 seconds.
2. Check DTC.

Is DTC detected?

- YES >> Go to [EC-163, "Diagnosis Procedure"](#).
- NO >> GO TO 4.

4. PERFORM DTC CONFIRMATION PROCEDURE FOR DTC P0103-II

1. Start engine and wait at least 5 seconds.
2. Check DTC.

P0102, P0103 MAF SENSOR

[VQ35DE]

< COMPONENT DIAGNOSIS >

Is DTC detected?

- YES >> Go to [EC-163, "Diagnosis Procedure"](#).
- NO >> INSPECTION END

A

Diagnosis Procedure

INFOID:000000003387961

EC

1.INSPECTION START

Confirm the detected DTC.

C

Which DTC is detected?

- P0102 >> GO TO 2.
- P0103 >> GO TO 3.

D

2.CHECK INTAKE SYSTEM

Check the following for connection.

- Air duct
- Vacuum hoses
- Intake air passage between air duct to intake manifold

E

Is the inspection result normal?

F

- YES >> GO TO 3.
- NO >> Reconnect the parts.

3.CHECK GROUND CONNECTION

G

1. Turn ignition switch OFF.
2. Check ground connection E38. Refer to Ground Inspection in [GI-43, "Circuit Inspection"](#).

H

Is the inspection result normal?

- YES >> GO TO 4.
- NO >> Repair or replace ground connection.

I

4.CHECK MAF SENSOR POWER SUPPLY CIRCUIT

1. Disconnect mass air flow (MAF) sensor harness connector.
2. Turn ignition switch ON.
3. Check the voltage between MAF sensor harness connector and ground.

J

MAF sensor		Ground	Voltage
Connector	Terminal		
F4	5	Ground	Battery voltage

K

Is the inspection result normal?

L

- YES >> GO TO 6.
- NO >> GO TO 5.

M

5.DETECT MALFUNCTIONING PART

Check the following.

- Harness connectors E7, F121
- Harness for open or short between mass air flow sensor and ECM
- Harness for open or short between mass air flow sensor and IPDM E/R

N

>> Repair open circuit, short to ground or short to power in harness or connectors.

O

6.CHECK MAF SENSOR GROUND CIRCUIT FOR OPEN AND SHORT

1. Turn ignition switch OFF.
2. Disconnect ECM harness connector.
3. Check the continuity between MAF sensor harness connector and ECM harness connector.

P

P0102, P0103 MAF SENSOR

[VQ35DE]

< COMPONENT DIAGNOSIS >

MAF sensor		ECM		Continuity
Connector	Terminal	Connector	Terminal	
F4	4	F8	56	Existed

4. Also check harness for short to ground and short to power.

Is the inspection result normal?

YES >> GO TO 7.

NO >> Repair open circuit, short to ground or short to power in harness or connectors.

7. CHECK MAF SENSOR INPUT SIGNAL CIRCUIT FOR OPEN AND SHORT

1. Check the continuity between MAF sensor harness connector and ECM harness connector.

MAF sensor		ECM		Continuity
Connector	Terminal	Connector	Terminal	
F4	3	F8	58	Existed

2. Also check harness for short to ground and short to power.

Is the inspection result normal?

YES >> GO TO 8.

NO >> Repair open circuit, short to ground or short to power in harness or connectors.

8. CHECK MASS AIR FLOW SENSOR

Refer to [EC-164. "Component Inspection"](#).

Is the inspection result normal?

YES >> GO TO 9.

NO >> Replace mass air flow sensor.

9. CHECK INTERMITTENT INCIDENT

Refer to [GI-40. "Intermittent Incident"](#).

>> INSPECTION END

Component Inspection

INFOID:000000003591559

1. CHECK MASS AIR FLOW SENSOR-I

With CONSULT-III

1. Reconnect all harness connectors disconnected.
2. Start engine and warm it up to normal operating temperature.
3. Connect CONSULT-III and select "DATA MONITOR" mode.
4. Select "MAS A/F SE-B1" and check indication under the following conditions.

Monitor item	Condition	MAS A/F SE-B1 (V)
MAS A/F SE-B1	Ignition switch ON (Engine stopped.)	Approx. 0.4
	Idle (Engine is warmed-up to normal operating temperature.)	0.9 - 1.2
	2,500 rpm (Engine is warmed-up to normal operating temperature.)	1.6 - 1.9
	Idle to approximately 4,000 rpm	0.9 - 1.2 to Approx. 2.4*

*: Check for linear voltage rise in response to engine being increased to approximately 4,000 rpm.

Without CONSULT-III

1. Reconnect all harness connectors disconnected.
2. Start engine and warm it up to normal operating temperature.
3. Check the voltage between ECM harness connector terminals under the following conditions.

P0102, P0103 MAF SENSOR

< COMPONENT DIAGNOSIS >

[VQ35DE]

ECM			Condition	Voltage (V)
Connector	+	-		
		Terminal	Terminal	
F8	58 (MAF sensor signal)	56 (Sensor ground)	Ignition switch ON (Engine stopped.)	Approx. 0.4
			Idle (Engine is warmed-up to normal operating temperature.)	0.9 - 1.2
			2,500 rpm (Engine is warmed-up to normal operating temperature.)	1.6 - 1.9
			Idle to approximately 4,000 rpm	0.9 - 1.2 to Approx. 2.4*

*: Check for linear voltage rise in response to engine being increased to approximately 4,000 rpm.

Is the inspection result normal?

YES >> INSPECTION END

NO >> GO TO 2.

2. CHECK FOR THE CAUSE OF UNEVEN AIR FLOW THROUGH MASS AIR FLOW SENSOR

Check for the cause of uneven air flow through mass air flow sensor. Refer to the following.

- Crushed air ducts
- Malfunctioning seal of air cleaner element
- Uneven dirt of air cleaner element
- Improper specification of intake air system parts

Is the inspection result normal?

YES >> GO TO 4.

NO >> GO TO 3.

3. CHECK MASS AIR FLOW SENSOR-II

 **With CONSULT-III**

1. Repair or replace malfunctioning part.
2. Start engine and warm it up to normal operating temperature.
3. Connect CONSULT-III and select "DATA MONITOR" mode.
4. Select "MAS A/F SE-B1" and check indication under the following conditions.

Monitor item	Condition	MAS A/F SE-B1 (V)
MAS A/F SE-B1	Ignition switch ON (Engine stopped.)	Approx. 0.4
	Idle (Engine is warmed-up to normal operating temperature.)	0.9 - 1.2
	2,500 rpm (Engine is warmed-up to normal operating temperature.)	1.6 - 1.9
	Idle to approximately 4,000 rpm	0.9 - 1.2 to Approx. 2.4*

*: Check for linear voltage rise in response to engine being increased to approximately 4,000 rpm.

 **Without CONSULT-III**

1. Repair or replace malfunctioning part.
2. Start engine and warm it up to normal operating temperature.
3. Check the voltage between ECM harness connector terminals under the following conditions.

ECM			Condition	Voltage (V)
Connector	+	-		
		Terminal	Terminal	
F8	58 (MAF sensor signal)	56 (Sensor ground)	Ignition switch ON (Engine stopped.)	Approx. 0.4
			Idle (Engine is warmed-up to normal operating temperature.)	0.9 - 1.2
			2,500 rpm (Engine is warmed-up to normal operating temperature.)	1.6 - 1.9
			Idle to approximately 4,000 rpm	0.9 - 1.2 to Approx. 2.4*

*: Check for linear voltage rise in response to engine being increased to approximately 4,000 rpm.

Is the inspection result normal?

P0102, P0103 MAF SENSOR

[VQ35DE]

< COMPONENT DIAGNOSIS >

- YES >> INSPECTION END
 NO >> GO TO 4.

4. CHECK MASS AIR FLOW SENSOR-III

With CONSULT-III

1. Turn ignition switch OFF.
2. Disconnect mass air flow sensor harness connector and reconnect it again.
3. Start engine and warm it up to normal operating temperature.
4. Connect CONSULT-III and select "DATA MONITOR" mode.
5. Select "MAS A/F SE-B1" and check indication under the following conditions.

Monitor item	Condition	MAS A/F SE-B1 (V)
MAS A/F SE-B1	Ignition switch ON (Engine stopped.)	Approx. 0.4
	Idle (Engine is warmed-up to normal operating temperature.)	0.9 - 1.2
	2,500 rpm (Engine is warmed-up to normal operating temperature.)	1.6 - 1.9
	Idle to approximately 4,000 rpm	0.9 - 1.2 to Approx. 2.4*

*: Check for linear voltage rise in response to engine being increased to approximately 4,000 rpm.

Without CONSULT-III

1. Turn ignition switch OFF.
2. Disconnect mass air flow sensor harness connector and reconnect it again.
3. Start engine and warm it up to normal operating temperature.
4. Check the voltage between ECM harness connector terminals under the following conditions.

Connector	ECM		Condition	Voltage (V)
	+	-		
	Terminal	Terminal		
F8	58 (MAF sensor signal)	56 (Sensor ground)	Ignition switch ON (Engine stopped.)	Approx. 0.4
			Idle (Engine is warmed-up to normal operating temperature.)	0.9 - 1.2
			2,500 rpm (Engine is warmed-up to normal operating temperature.)	1.6 - 1.9
			Idle to approximately 4,000 rpm	0.9 - 1.2 to Approx. 2.4*

*: Check for linear voltage rise in response to engine being increased to approximately 4,000 rpm.

Is the inspection result normal?

- YES >> INSPECTION END
 NO >> Clean or replace mass air flow sensor.

P0112, P0113 IAT SENSOR

< COMPONENT DIAGNOSIS >

[VQ35DE]

P0112, P0113 IAT SENSOR

Description

INFOID:000000003387963

The intake air temperature sensor is built-into the mass air flow sensor (1). The sensor detects intake air temperature and transmits a signal to the ECM.

The temperature sensing unit uses a thermistor which is sensitive to the change in temperature. Electrical resistance of the thermistor decreases in response to the rise in temperature.

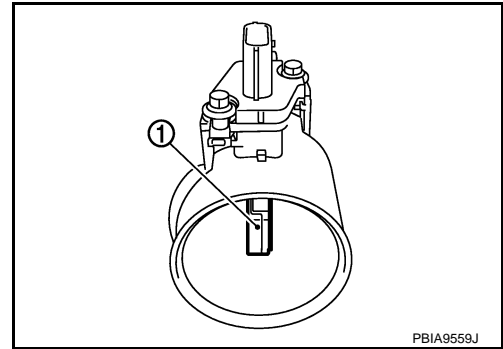

<Reference data>

Intake air temperature [°C (°F)]	Voltage* (V)	Resistance (kΩ)
25 (77)	3.3	1.800 - 2.200
80 (176)	1.2	0.283 - 0.359

*: These data are reference values and are measured between ECM terminals 50 (Intake air temperature sensor) and 56 (Sensor ground).

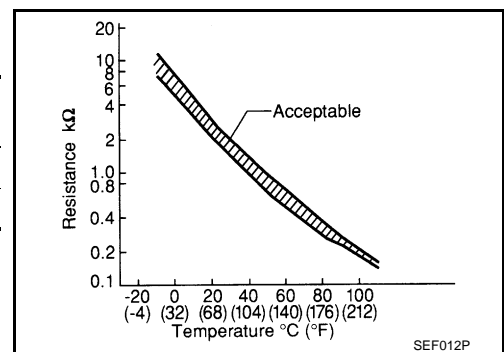

DTC Logic

INFOID:000000003387964

DTC DETECTION LOGIC

DTC No.	Trouble diagnosis name	DTC detecting condition	Possible cause
P0112	Intake air temperature sensor circuit low input	An excessively low voltage from the sensor is sent to ECM.	<ul style="list-style-type: none"> • Harness or connectors (The sensor circuit is open or shorted.) • Intake air temperature sensor
P0113	Intake air temperature sensor circuit high input	An excessively high voltage from the sensor is sent to ECM.	

DTC CONFIRMATION PROCEDURE

1. PRECONDITIONING

If DTC Confirmation Procedure has been previously conducted, always perform the following before conducting the next test.

1. Turn ignition switch OFF and wait at least 10 seconds.
2. Turn ignition switch ON.
3. Turn ignition switch OFF and wait at least 10 seconds.

>> GO TO 2.

2. PERFORM DTC CONFIRMATION PROCEDURE

1. Turn ignition switch ON and wait at least 5 seconds.
2. Check 1st trip DTC.

Is 1st trip DTC detected?

- YES >> Go to [EC-168, "Diagnosis Procedure"](#).
- NO >> INSPECTION END

P0112, P0113 IAT SENSOR

[VQ35DE]

< COMPONENT DIAGNOSIS >

Diagnosis Procedure

INFOID:000000003387965

1. CHECK GROUND CONNECTION

1. Turn ignition switch OFF.
2. Check ground connection E38. Refer to Ground Inspection in [GI-43. "Circuit Inspection"](#).

Is the inspection result normal?

- YES >> GO TO 2.
NO >> Repair or replace ground connection.

2. CHECK INTAKE AIR TEMPERATURE SENSOR POWER SUPPLY CIRCUIT

1. Disconnect mass air flow sensor (with intake air temperature sensor) harness connector.
2. Turn ignition switch ON.
3. Check the voltage between mass air flow sensor harness connector and ground.

MAF sensor		Ground	Voltage
Connector	Terminal		
F4	2	Ground	Approx. 5 V

Is the inspection result normal?

- YES >> GO TO 3.
NO >> Repair open circuit, short to ground or short to power in harness or connectors.

3. CHECK INTAKE AIR TEMPERATURE SENSOR GROUND CIRCUIT FOR OPEN AND SHORT

1. Turn ignition switch OFF.
2. Disconnect ECM harness connector.
3. Check harness continuity between mass air flow sensor harness connector and ECM harness connector.

MAF sensor		ECM		Continuity
Connector	Terminal	Connector	Terminal	
F4	1	F8	56	Existed

4. Also check harness for short to ground and short to power.

Is the inspection result normal?

- YES >> GO TO 4.
NO >> Repair open circuit, short to ground or short to power in harness or connectors.

4. CHECK INTAKE AIR TEMPERATURE SENSOR

Refer to [EC-168. "Component Inspection"](#).

Is the inspection result normal?

- YES >> GO TO 5.
NO >> Replace mass air flow sensor (with intake air temperature sensor).

5. CHECK INTERMITTENT INCIDENT

Refer to [GI-40. "Intermittent Incident"](#).

>> INSPECTION END

Component Inspection

INFOID:000000003387966

1. CHECK INTAKE AIR TEMPERATURE SENSOR

1. Turn ignition switch OFF.
2. Disconnect mass air flow sensor harness connector.
3. Check resistance between mass air flow sensor terminals as per the following.

P0112, P0113 IAT SENSOR

[VQ35DE]

< COMPONENT DIAGNOSIS >

Terminal	Condition		Resistance (kΩ)
1 and 2	Temperature [°C (°F)]	25 (77)	1.800 - 2.200

Is the inspection result normal?

YES >> INSPECTION END

NO >> Replace mass air flow sensor (with intake air temperature sensor).

A

EC

C

D

E

F

G

H

I

J

K

L

M

N

O

P

P0116 ECT SENSOR

< COMPONENT DIAGNOSIS >

[VQ35DE]

P0116 ECT SENSOR

Description

INFOID:000000003387967

The engine coolant temperature sensor is used to detect the engine coolant temperature. The sensor modifies a voltage signal from the ECM. The modified signal returns to the ECM as the engine coolant temperature input. The sensor uses a thermistor which is sensitive to the change in temperature. The electrical resistance of the thermistor decreases as temperature increases.

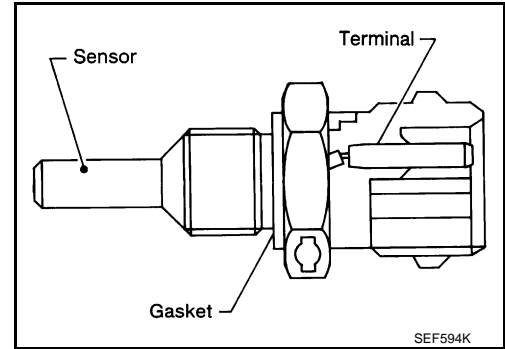

<Reference data>

Engine coolant temperature [°C (°F)]	Voltage* (V)	Resistance (kΩ)
-10 (14)	4.4	7.0 - 11.4
20 (68)	3.5	2.1 - 2.9
50 (122)	2.2	0.68 - 1.00
90 (194)	0.9	0.236 - 0.260

*: These data are reference values and are measured between ECM terminals 46 (Engine coolant temperature sensor) and 52 (Sensor ground).

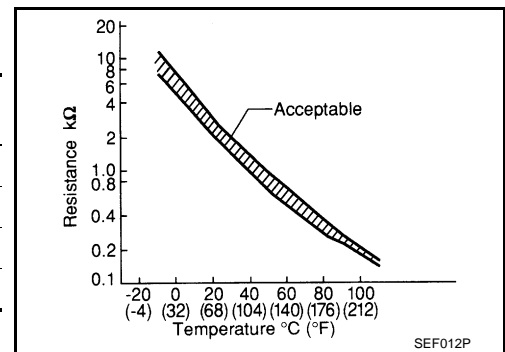

DTC Logic

INFOID:000000003544736

DTC DETECTION LOGIC

NOTE:

If DTC P0116 is displayed with P0117 or P0118, first perform the trouble diagnosis for DTC P0117, P0118. Refer to [EC-172. "DTC Logic"](#).

DTC No.	Trouble diagnosis name	DTC detecting condition	Possible cause
P0116	Engine coolant temperature sensor circuit range/performance	Engine coolant temperature signal from engine coolant temperature sensor does not fluctuate, even when some time has passed after starting the engine with pre-warming up condition.	<ul style="list-style-type: none"> • Harness or connectors (High or low resistance in the circuit) • Engine coolant temperature sensor

DTC CONFIRMATION PROCEDURE

1. PRECONDITIONING

If DTC Confirmation Procedure has been previously conducted, always perform the following before conducting the next test.

1. Turn ignition switch OFF and wait at least 10 seconds.
2. Turn ignition switch ON.
3. Turn ignition switch OFF and wait at least 10 seconds.

TEST CONDITION:

Before performing the following procedure, do not add fuel.

>> GO TO 2.

2. PERFORM DTC CONFIRMATION PROCEDURE

1. Start engine and warm it up to normal operating temperature.
2. Rev engine up to 2,000 rpm for more than 10 minutes.
3. Move the vehicle to a cool place, then stop engine and turn ignition switch OFF.

P0116 ECT SENSOR

[VQ35DE]

< COMPONENT DIAGNOSIS >

4. Check resistance between "fuel level sensor unit and fuel pump" terminals 4 and 5.
5. Soak the vehicle until the resistance between "fuel level sensor unit and fuel pump" terminals 4 and 5 becomes 0.5 kΩ higher than the value measured before soaking.

CAUTION:

Never turn ignition switch ON during soaking.

NOTE:

Soak time changes depending on ambient air temperature. It may take several hours.

6. Start engine and let it idle for 5 minutes.
7. Check 1st trip DTC.

Is 1st trip DTC detected?

- YES >> [EC-171, "Diagnosis Procedure"](#)
NO >> INSPECTION END

Diagnosis Procedure

INFOID:000000003544737

1.CHECK GROUND CONNECTION

1. Turn ignition switch OFF.
2. Check ground connection E38. Refer to Ground Inspection in [GI-43, "Circuit Inspection"](#).

Is the inspection result normal?

- YES >> GO TO 2.
NO >> Repair or replace ground connection.

2.CHECK ENGINE COOLANT TEMPERATURE SENSOR

Refer to [EC-171, "Component Inspection"](#).

Is the inspection result normal?

- YES >> GO TO 3.
NO >> Replace engine coolant temperature sensor.

3.CHECK INTERMITTENT INCIDENT

Refer to [GI-40, "Intermittent Incident"](#).

>> INSPECTION END

Component Inspection

INFOID:000000003387970

1.CHECK ENGINE COOLANT TEMPERATURE SENSOR

1. Turn ignition switch OFF.
2. Disconnect engine coolant temperature sensor harness connector.
3. Remove engine coolant temperature sensor.
4. Check resistance between engine coolant temperature sensor terminals as per the following.

Terminals	Condition	Resistance (kΩ)	
1 and 2	Temperature [°C (°F)]	20 (68)	2.1 - 2.9
		50 (122)	0.68 - 1.00
		90 (194)	0.236 - 0.260

Is the inspection result normal?

- YES >> INSPECTION END
NO >> Replace engine coolant temperature sensor.

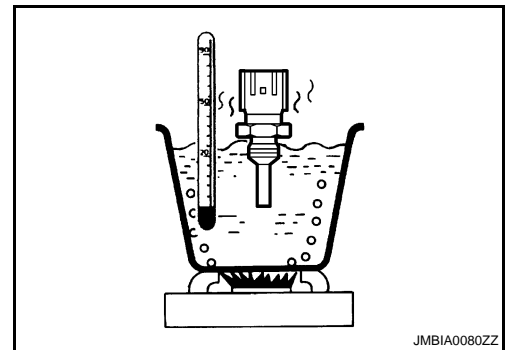

P0117, P0118 ECT SENSOR

< COMPONENT DIAGNOSIS >

[VQ35DE]

P0117, P0118 ECT SENSOR

Description

INFOID:000000003625295

The engine coolant temperature sensor is used to detect the engine coolant temperature. The sensor modifies a voltage signal from the ECM. The modified signal returns to the ECM as the engine coolant temperature input. The sensor uses a thermistor which is sensitive to the change in temperature. The electrical resistance of the thermistor decreases as temperature increases.

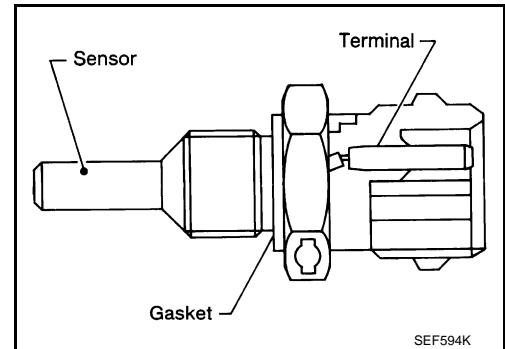

<Reference data>

Engine coolant temperature [°C (°F)]	Voltage* (V)	Resistance (kΩ)
-10 (14)	4.4	7.0 - 11.4
20 (68)	3.5	2.1 - 2.9
50 (122)	2.2	0.68 - 1.00
90 (194)	0.9	0.236 - 0.260

*: These data are reference values and are measured between ECM terminals 46 (Engine coolant temperature sensor) and 52 (Sensor ground).

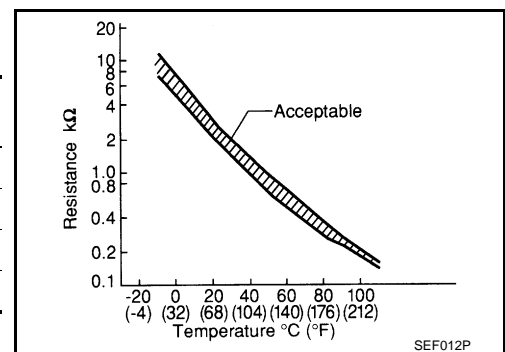

DTC Logic

INFOID:000000003387968

DTC DETECTION LOGIC

DTC No.	Trouble Diagnosis Name	DTC detecting condition	Possible Cause
P0117	Engine coolant temperature sensor circuit low input	An excessively low voltage from the sensor is sent to ECM.	<ul style="list-style-type: none"> • Harness or connectors (The sensor circuit is open or shorted.) • Engine coolant temperature sensor
P0118	Engine coolant temperature sensor circuit high input	An excessively high voltage from the sensor is sent to ECM.	

DTC CONFIRMATION PROCEDURE

1. PRECONDITIONING

If DTC Confirmation Procedure has been previously conducted, always perform the following before conducting the next test.

1. Turn ignition switch OFF and wait at least 10 seconds.
2. Turn ignition switch ON.
3. Turn ignition switch OFF and wait at least 10 seconds.

>> GO TO 2.

2. PERFORM DTC CONFIRMATION PROCEDURE

1. Turn ignition switch ON and wait at least 5 seconds.
2. Check DTC.

Is DTC detected?

- YES >> Go to [EC-173, "Diagnosis Procedure"](#).
 NO >> INSPECTION END

P0117, P0118 ECT SENSOR

< COMPONENT DIAGNOSIS >

[VQ35DE]

Diagnosis Procedure

INFOID:000000003387969

1. CHECK GROUND CONNECTION

1. Turn ignition switch OFF.
2. Check ground connection E38. Refer to Ground Inspection in [GI-43. "Circuit Inspection"](#).

Is the inspection result normal?

- YES >> GO TO 2.
NO >> Repair or replace ground connection.

2. CHECK ECT SENSOR POWER SUPPLY CIRCUIT

1. Disconnect engine coolant temperature (ECT) sensor harness connector.
2. Turn ignition switch ON.
3. Check the voltage between ECT sensor harness connector and ground.

ECT sensor		Ground	Voltage
Connector	Terminal		
F80	1	Ground	Approx. 5 V

Is the inspection result normal?

- YES >> GO TO 3.
NO >> Repair open circuit, short to ground or short to power in harness or connectors.

3. CHECK ECT SENSOR GROUND CIRCUIT FOR OPEN AND SHORT

1. Turn ignition switch OFF.
2. Disconnect ECM harness connector.
3. Check the continuity between ECT sensor harness connector and ECM harness connector.

ECT sensor		ECM		Continuity
Connector	Terminal	Connector	Terminal	
F80	2	F8	52	Existed

4. Also check harness for short to ground and short to power.

Is the inspection result normal?

- YES >> GO TO 4.
NO >> Repair open circuit, short to ground or short to power in harness or connectors.

4. CHECK ENGINE COOLANT TEMPERATURE SENSOR

Refer to [EC-173. "Component Inspection"](#).

Is the inspection result normal?

- YES >> GO TO 5.
NO >> Replace engine coolant temperature sensor.

5. CHECK INTERMITTENT INCIDENT

Refer to [GI-40. "Intermittent Incident"](#).

>> INSPECTION END

Component Inspection

INFOID:000000003625296

1. CHECK ENGINE COOLANT TEMPERATURE SENSOR

1. Turn ignition switch OFF.
2. Disconnect engine coolant temperature sensor harness connector.
3. Remove engine coolant temperature sensor.

P0117, P0118 ECT SENSOR

[VQ35DE]

< COMPONENT DIAGNOSIS >

4. Check resistance between engine coolant temperature sensor terminals as per the following.

Terminals	Condition		Resistance (k Ω)
1 and 2	Temperature [$^{\circ}$ C ($^{\circ}$ F)]	20 (68)	2.1 - 2.9
		50 (122)	0.68 - 1.00
		90 (194)	0.236 - 0.260

Is the inspection result normal?

YES >> INSPECTION END

NO >> Replace engine coolant temperature sensor.

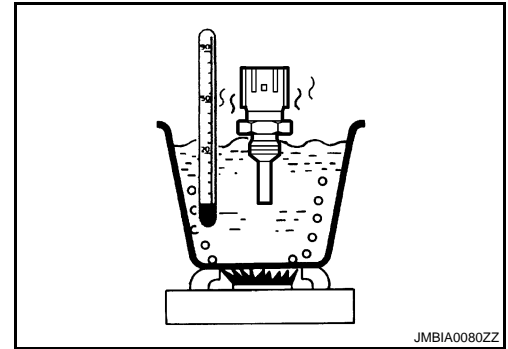

P0122, P0123 TP SENSOR

Description

INFOID:000000003387971

Electric throttle control actuator consists of throttle control motor, throttle position sensor, etc. The throttle position sensor responds to the throttle valve movement.

The throttle position sensor has two sensors. These sensors are a kind of potentiometer which transform the throttle valve position into output voltage, and emit the voltage signals to the ECM. The ECM judges the current opening angle of the throttle valve from these signals and controls the throttle valve opening angle in response to driving conditions via the throttle control motor.

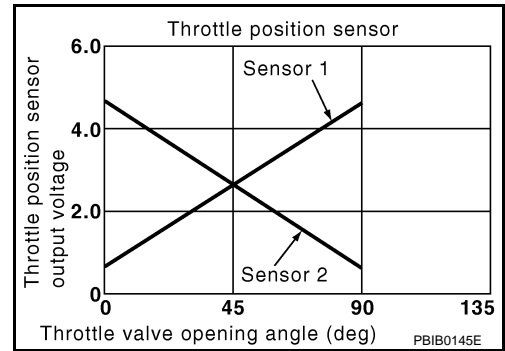

DTC Logic

INFOID:000000003387972

DTC DETECTION LOGIC

NOTE:

If DTC P0122 or P0123 is displayed with DTC P0643, first perform the trouble diagnosis for DTC P0643. Refer to [EC-347, "DTC Logic"](#).

DTC No.	Trouble diagnosis name	DTC detecting condition	Possible cause
P0122	Throttle position sensor 2 circuit low input	An excessively low voltage from the TP sensor 2 is sent to ECM.	<ul style="list-style-type: none"> Harness or connectors (TP sensor 2 circuit is open or shorted.) Electric throttle control actuator (TP sensor 2)
P0123	Throttle position sensor 2 circuit high input	An excessively high voltage from the TP sensor 2 is sent to ECM.	

DTC CONFIRMATION PROCEDURE

1. PRECONDITIONING

If DTC Confirmation Procedure has been previously conducted, always perform the following before conducting the next test.

1. Turn ignition switch OFF and wait at least 10 seconds.
2. Turn ignition switch ON.
3. Turn ignition switch OFF and wait at least 10 seconds.

TESTING CONDITION:

Before performing the following procedure, confirm that battery voltage is more than 8 V at idle.

>> GO TO 2.

2. PERFORM DTC CONFIRMATION PROCEDURE

1. Start engine and let it idle for 1 second.
2. Check DTC.

Is DTC detected?

- YES >> Go to [EC-175, "Diagnosis Procedure"](#).
- NO >> INSPECTION END

Diagnosis Procedure

INFOID:000000003387973

1. CHECK GROUND CONNECTION

1. Turn ignition switch OFF.
2. Check ground connection E38. Refer to Ground Inspection in [GI-43, "Circuit Inspection"](#).

Is the inspection result normal?

- YES >> GO TO 2.
- NO >> Repair or replace ground connection.

P0122, P0123 TP SENSOR

[VQ35DE]

< COMPONENT DIAGNOSIS >

2. CHECK THROTTLE POSITION SENSOR 2 POWER SUPPLY CIRCUIT

1. Disconnect electric throttle control actuator harness connector.
2. Turn ignition switch ON.
3. Check the voltage between electric throttle control actuator harness connector and ground.

Electric throttle control actuator		Ground	Voltage
Connector	Terminal		
F29	1	Ground	Approx. 5 V

Is the inspection result normal?

YES >> GO TO 3.

NO >> Repair open circuit, short to ground or short to power in harness or connectors.

3. CHECK THROTTLE POSITION SENSOR 2 GROUND CIRCUIT FOR OPEN AND SHORT

1. Turn ignition switch OFF.
2. Disconnect ECM harness connector.
3. Check the continuity between electric throttle control actuator harness connector and ECM harness connector.

Electric throttle control actuator		ECM		Continuity
Connector	Terminal	Connector	Terminal	
F29	4	F8	36	Existed

4. Also check harness for short to ground and short to power.

Is the inspection result normal?

YES >> GO TO 4.

NO >> Repair open circuit, short to ground or short to power in harness or connectors.

4. CHECK THROTTLE POSITION SENSOR 2 INPUT SIGNAL CIRCUIT FOR OPEN AND SHORT

1. Check the continuity between electric throttle control actuator harness connector and ECM harness connector.

Electric throttle control actuator		ECM		Continuity
Connector	Terminal	Connector	Terminal	
F29	3	F8	38	Existed

2. Also check harness for short to ground and short to power.

Is the inspection result normal?

YES >> GO TO 5.

NO >> Repair open circuit, short to ground or short to power in harness or connectors.

5. CHECK THROTTLE POSITION SENSOR

Refer to [EC-177, "Component Inspection"](#).

Is the inspection result normal?

YES >> GO TO 7.

NO >> GO TO 6.

6. REPLACE ELECTRIC THROTTLE CONTROL ACTUATOR

1. Replace electric throttle control actuator.
2. Refer to [EC-177, "Special Repair Requirement"](#).

>> INSPECTION END

7. CHECK INTERMITTENT INCIDENT

Refer to [GI-40, "Intermittent Incident"](#).

P0122, P0123 TP SENSOR

< COMPONENT DIAGNOSIS >

[VQ35DE]

>> INSPECTION END

Component Inspection

INFOID:000000003387974

1. CHECK THROTTLE POSITION SENSOR

1. Turn ignition switch OFF.
2. Reconnect all harness connectors disconnected.
3. Perform [EC-17, "THROTTLE VALVE CLOSED POSITION LEARNING : Special Repair Requirement"](#).
4. Turn ignition switch ON.
5. Set selector lever to D position.
6. Check the voltage between ECM harness connector terminals under the following conditions.

ECM			Condition	Voltage
Connector	+	-		
	Terminal	Terminal		
F8	37 (TP sensor 1 signal)	36 (Sensor ground)	Fully released	More than 0.36 V
			Fully depressed	Less than 4.75 V
	38 (TP sensor 2 signal)		Fully released	Less than 4.75 V
			Fully depressed	More than 0.36 V

Is the inspection result normal?

- YES >> INSPECTION END
NO >> GO TO 2.

2. REPLACE ELECTRIC THROTTLE CONTROL ACTUATOR

1. Replace electric throttle control actuator.
2. Go to [EC-177, "Special Repair Requirement"](#).

>> INSPECTION END

Special Repair Requirement

INFOID:000000003387975

1. PERFORM THROTTLE VALVE CLOSED POSITION LEARNING

Refer to [EC-17, "THROTTLE VALVE CLOSED POSITION LEARNING : Special Repair Requirement"](#)

>> GO TO 2.

2. PERFORM IDLE AIR VOLUME LEARNING

Refer to [EC-17, "IDLE AIR VOLUME LEARNING : Special Repair Requirement"](#)

>> END

P0125 ECT SENSOR

< COMPONENT DIAGNOSIS >

[VQ35DE]

P0125 ECT SENSOR

Description

INFOID:000000003624712

The engine coolant temperature sensor is used to detect the engine coolant temperature. The sensor modifies a voltage signal from the ECM. The modified signal returns to the ECM as the engine coolant temperature input. The sensor uses a thermistor which is sensitive to the change in temperature. The electrical resistance of the thermistor decreases as temperature increases.

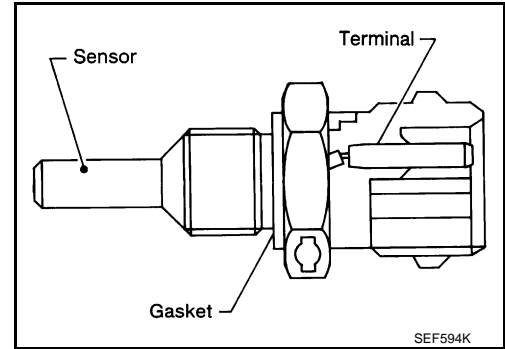

<Reference data>

Engine coolant temperature [°C (°F)]	Voltage* (V)	Resistance (kΩ)
-10 (14)	4.4	7.0 - 11.4
20 (68)	3.5	2.1 - 2.9
50 (122)	2.2	0.68 - 1.00
90 (194)	0.9	0.236 - 0.260

*: These data are reference values and are measured between ECM terminals 46 (Engine coolant temperature sensor) and 52 (Sensor ground).

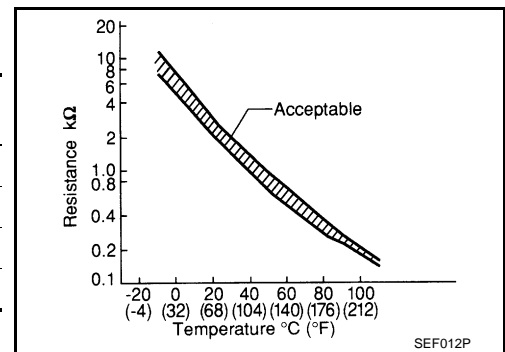

DTC Logic

INFOID:000000003387977

DTC DETECTION LOGIC

NOTE:

- If DTC P0125 is displayed with P0116, first perform the trouble diagnosis for DTC P0116. Refer to [EC-170, "DTC Logic"](#).
- If DTC P0125 is displayed with P0117 or P0118, first perform the trouble diagnosis for DTC P0117, P0118. Refer to [EC-172, "DTC Logic"](#).

DTC No.	Trouble diagnosis name	DTC detecting condition	Possible cause
P0125	Insufficient engine coolant temperature for closed loop fuel control	<ul style="list-style-type: none"> • Voltage sent to ECM from the sensor is not practical, even when some time has passed after starting the engine. • Engine coolant temperature is insufficient for closed loop fuel control. 	<ul style="list-style-type: none"> • Harness or connectors (High resistance in the circuit) • Engine coolant temperature sensor • Thermostat

DTC CONFIRMATION PROCEDURE

1. PRECONDITIONING

If DTC Confirmation Procedure has been previously conducted, always perform the following before conducting the next test.

1. Turn ignition switch OFF and wait at least 10 seconds.
2. Turn ignition switch ON.
3. Turn ignition switch OFF and wait at least 10 seconds.

>> GO TO 2.

2. CHECK ENGINE COOLANT TEMPERATURE SENSOR FUNCTION

Ⓟ With CONSULT-III

1. Turn ignition switch ON.

P0125 ECT SENSOR

[VQ35DE]

< COMPONENT DIAGNOSIS >

2. Select "DATA MONITOR" mode with CONSULT-III.
3. Check that "COOLAN TEMP/S" is above 10°C (50°F).

With GST

Follow the procedure "With CONSULT-III" above.

Is the temperature above 10°C (50°F)?

- YES >> INSPECTION END
NO >> GO TO 3.

3.PERFORM DTC CONFIRMATION PROCEDURE

With CONSULT-III

1. Start engine and run it for 65 minutes at idle speed.
If "COOLAN TEMP/S" increases to more than 10°C (50°F) within 65 minutes, stop engine because the test result will be OK.

CAUTION:

Never overheat engine.

2. Check 1st trip DTC.

With GST

Follow the procedure "With CONSULT-III" above.

Is 1st trip DTC detected?

- YES >> [EC-179. "Diagnosis Procedure"](#)
NO >> INSPECTION END

Diagnosis Procedure

INFOID:000000003387978

1.CHECK GROUND CONNECTION

1. Turn ignition switch OFF.
2. Check ground connection E38. Refer to Ground Inspection in [GI-43. "Circuit Inspection"](#).

Is the inspection result normal?

- YES >> GO TO 2.
NO >> Repair or replace ground connection.

2.CHECK ENGINE COOLANT TEMPERATURE SENSOR

Refer to [EC-179. "Component Inspection"](#).

Is the inspection result normal?

- YES >> GO TO 3.
NO >> Replace engine coolant temperature sensor.

3.CHECK THERMOSTAT OPERATION

When the engine is cold [lower than 70°C (158°F)] condition, grasp lower radiator hose and confirm that the engine coolant does not flow.

Is the inspection result normal?

- YES >> GO TO 4.
NO >> Repair or replace thermostat. Refer to [CO-23. "Removal and Installation"](#).

4.CHECK INTERMITTENT INCIDENT

Refer to [GI-40. "Intermittent Incident"](#).

>> INSPECTION END

Component Inspection

INFOID:000000003591570

1.CHECK ENGINE COOLANT TEMPERATURE SENSOR

1. Turn ignition switch OFF.
2. Disconnect engine coolant temperature sensor harness connector.
3. Remove engine coolant temperature sensor.

P0125 ECT SENSOR

[VQ35DE]

< COMPONENT DIAGNOSIS >

4. Check resistance between engine coolant temperature sensor terminals as per the following.

Terminals	Condition	Resistance (k Ω)	
1 and 2	Temperature [$^{\circ}$ C ($^{\circ}$ F)]	20 (68)	2.1 - 2.9
		50 (122)	0.68 - 1.00
		90 (194)	0.236 - 0.260

Is the inspection result normal?

YES >> INSPECTION END

NO >> Replace engine coolant temperature sensor.

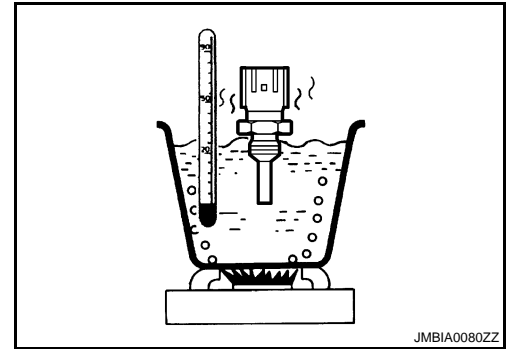

P0127 IAT SENSOR

< COMPONENT DIAGNOSIS >

[VQ35DE]

P0127 IAT SENSOR

Description

INFOID:000000003591562

The intake air temperature sensor is built-into the mass air flow sensor (1). The sensor detects intake air temperature and transmits a signal to the ECM.

The temperature sensing unit uses a thermistor which is sensitive to the change in temperature. Electrical resistance of the thermistor decreases in response to the rise in temperature.

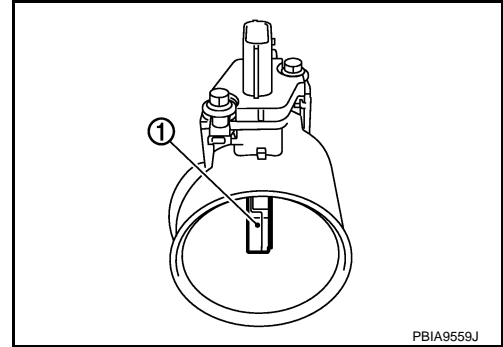

<Reference data>

Intake air temperature [°C (°F)]	Voltage* (V)	Resistance (kΩ)
25 (77)	3.3	1.800 - 2.200
80 (176)	1.2	0.283 - 0.359

*: These data are reference values and are measured between ECM terminals 50 (Intake air temperature sensor) and 56 (Sensor ground).

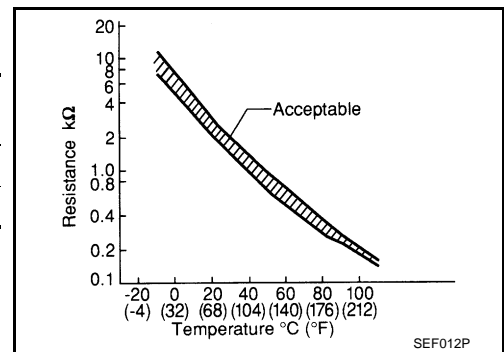

DTC Logic

INFOID:000000003387981

DTC DETECTION LOGIC

DTC No.	Trouble diagnosis name	DTC detecting condition	Possible cause
P0127	Intake air temperature too high	Rationally incorrect voltage from the sensor is sent to ECM, compared with the voltage signal from engine coolant temperature sensor.	<ul style="list-style-type: none"> • Harness or connectors (The sensor circuit is open or shorted) • Intake air temperature sensor

DTC CONFIRMATION PROCEDURE

1. PRECONDITIONING

If DTC Confirmation Procedure has been previously conducted, always perform the following before conducting the next test.

1. Turn ignition switch OFF and wait at least 10 seconds.
2. Turn ignition switch ON.
3. Turn ignition switch OFF and wait at least 10 seconds.

TESTING CONDITION:

This test may be conducted with the drive wheels lifted in the shop or by driving the vehicle. If a road test is expected to be easier, it is unnecessary to lift the vehicle.

>> GO TO 2.

2. PERFORM DTC CONFIRMATION PROCEDURE

Ⓜ With CONSULT-III

1. Wait until engine coolant temperature is less than 90°C (194°F)
 - Turn ignition switch ON.
 - Select "DATA MONITOR" mode with CONSULT-III.
 - Check the engine coolant temperature.

P0127 IAT SENSOR

[VQ35DE]

< COMPONENT DIAGNOSIS >

- If the engine coolant temperature is not less than 90°C (194°F), turn ignition switch OFF and cool down engine.

NOTE:

Perform the following steps before engine coolant temperature is above 90°C (194°F).

2. Turn ignition switch ON.
3. Select "DATA MONITOR" mode with CONSULT-III.
4. Start engine.
5. Hold vehicle speed at more than 70 km/h (43 MPH) for 100 consecutive seconds.

CAUTION:

Always drive vehicle at a safe speed.

6. Check 1st trip DTC.

With GST

Follow the procedure "With CONSULT-III" above.

Is 1st trip DTC detected?

- YES >> Go to [EC-182, "Diagnosis Procedure"](#).
- NO >> INSPECTION END

Diagnosis Procedure

INFOID:000000003387982

1.CHECK GROUND CONNECTION

1. Turn ignition switch OFF.
2. Check ground connection E38. Refer to Ground Inspection in [GI-43, "Circuit Inspection"](#).

Is the inspection result normal?

- YES >> GO TO 2.
- NO >> Repair or replace ground connection.

2.CHECK INTAKE AIR TEMPERATURE SENSOR

Refer to [EC-182, "Component Inspection"](#).

Is the inspection result normal?

- YES >> GO TO 3.
- NO >> Replace mass air flow sensor (with intake air temperature sensor).

3.CHECK INTERMITTENT INCIDENT

Refer to [GI-40, "Intermittent Incident"](#).

>> INSPECTION END

Component Inspection

INFOID:000000003591563

1.CHECK INTAKE AIR TEMPERATURE SENSOR

1. Turn ignition switch OFF.
2. Disconnect mass air flow sensor harness connector.
3. Check resistance between mass air flow sensor terminals as per the following.

Terminal	Condition	Resistance (kΩ)
1 and 2	Temperature [°C (°F)]	25 (77) 1.800 - 2.200

Is the inspection result normal?

- YES >> INSPECTION END
- NO >> Replace mass air flow sensor (with intake air temperature sensor).

P0128 THERMOSTAT FUNCTION

< COMPONENT DIAGNOSIS >

[VQ35DE]

P0128 THERMOSTAT FUNCTION

DTC Logic

INFOID:000000003387984

DTC DETECTION LOGIC

NOTE:

If DTC P0128 is displayed with DTC P0300, P0301, P0302, P0303, P0304, P0305 or P0306, first perform the trouble diagnosis for DTC P0300, P0301, P0302, P0303, P0304, P0305, P0306. Refer to [EC-251](#), "DTC Logic".

Engine coolant temperature has not risen enough to open the thermostat even though the engine has run long enough.

This is due to a leakage in the seal or the thermostat being stuck open.

DTC No.	Trouble diagnosis name	DTC detecting condition	Possible cause
P0128	Thermostat function	The engine coolant temperature does not reach to specified temperature even though the engine has run long enough.	<ul style="list-style-type: none">• Thermostat• Leakage from sealing portion of thermostat• Engine coolant temperature sensor

DTC CONFIRMATION PROCEDURE

NOTE:

Check vehicle specifications and VIN, then select the procedure to be performed. (Refer to the table below.)

Vehicle specification	Vehicle serial number	TYPE
2WD	Up to JN8AZ18U*9W100000	A
	From JN8AZ18U*9W100001	B
	Up to JN8AZ18U*9W710000	A
	From JN8AZ18U*9W710001	B
4WD	Up to JN8AZ18W*9W200000	A
	From JN8AZ18W*9W200001	B
	Up to JN8AZ18W*9W810000	A
	From JN8AZ18W*9W810001	B

TYPE A

1. PRECONDITIONING

If DTC Confirmation Procedure has been previously conducted, always perform the following before conducting the next test.

1. Turn ignition switch OFF and wait at least 10 seconds.
2. Turn ignition switch ON.
3. Turn ignition switch OFF and wait at least 10 seconds.

TESTING CONDITION:

- For best results, perform at ambient temperature of -10°C (14°F) or higher.
- For best results, perform at engine coolant temperature of -10°C (14°F) to 56°C (133°F).
- Before performing the following procedure, do not add fuel.

>> GO TO 2.

2. PERFORM DTC CONFIRMATION PROCEDURE

With CONSULT-III

1. Turn A/C switch OFF.
2. Turn blower fan switch OFF.
3. Turn ignition switch ON.
4. Select "COOLAN TEMP/S" in "DATA MONITOR" mode with CONSULT-III.
5. Check the indication of "COOLAN TEMP/S"
If it is below 56°C (133°F), go to next step.

P0128 THERMOSTAT FUNCTION

[VQ35DE]

< COMPONENT DIAGNOSIS >

If it is above 56°C (133°F), cool down the engine to less than 56°C (133°F). Then go to next steps.

6. Start engine.
7. Wait at idle for at least 30 minutes.
If "COOLAN TEMP/S" increases to more than 75°C (167°F) within 30 minutes, turn ignition switch OFF because the test result will be OK.
8. Check 1st trip DTC.

With GST

Follow the procedure "With CONSULT-III" above.

Is 1st trip DTC detected?

- YES >> Go to [EC-184, "Diagnosis Procedure"](#).
NO >> INSPECTION END

TYPE B

1. PRECONDITIONING

If DTC Confirmation Procedure has been previously conducted, always perform the following before conducting the next test.

1. Turn ignition switch OFF and wait at least 10 seconds.
2. Turn ignition switch ON.
3. Turn ignition switch OFF and wait at least 10 seconds.

TESTING CONDITION:

- For best results, perform at ambient temperature of -10°C (14°F) or higher.
- For best results, perform at engine coolant temperature of -10°C (14°F) to 56°C (133°F).
- Before performing the following procedure, do not add fuel.

>> GO TO 2.

2. PERFORM DTC CONFIRMATION PROCEDURE

With CONSULT-III

1. Turn A/C switch OFF.
2. Turn blower fan switch OFF.
3. Turn ignition switch ON.
4. Select "COOLAN TEMP/S" in "DATA MONITOR" mode with CONSULT-III.
5. Check the indication of "COOLAN TEMP/S"
If it is below 56°C (133°F), go to next step.
If it is above 56°C (133°F), cool down the engine to less than 56°C (133°F). Then go to next steps.
6. Start engine.
7. Drive vehicle for 10 consecutive minutes under the following conditions.

VHCL SPEED SE	More than 56 km/h (35 MPH)
---------------	----------------------------

CAUTION:

Always drive vehicle at a safe speed.

NOTE:

If "COOLAN TEMP/S" increases to more than 75°C (167°F) within 10 minutes, turn ignition switch OFF because the test result will be OK.

8. Check 1st trip DTC.

With GST

Follow the procedure "With CONSULT-III" above.

Is 1st trip DTC detected?

- YES >> Go to [EC-184, "Diagnosis Procedure"](#).
NO >> INSPECTION END

Diagnosis Procedure

INFOID:000000003387985

1. CHECK ENGINE COOLANT TEMPERATURE SENSOR

Refer to [EC-185, "Component Inspection"](#).

Is the inspection result normal?

- YES >> GO TO 2.

P0128 THERMOSTAT FUNCTION

[VQ35DE]

< COMPONENT DIAGNOSIS >

NO >> Replace engine coolant temperature sensor.

2.CHECK THERMOSTAT

Check thermostat. Refer to [CO-23, "Removal and Installation"](#).

Is the inspection result normal?

YES >> INSPECTION END

NO >> Replace thermostat.

Component Inspection

INFOID:000000003387986

1.CHECK ENGINE COOLANT TEMPERATURE SENSOR

1. Turn ignition switch OFF.
2. Disconnect engine coolant temperature sensor harness connector.
3. Remove engine coolant temperature sensor.
4. Check resistance between engine coolant temperature sensor terminals as per the following.

Terminals	Condition	Resistance (kΩ)	
1 and 2	Temperature [°C (°F)]	20 (68)	2.1 - 2.9
		50 (122)	0.68 - 1.00
		90 (194)	0.236 - 0.260

Is the inspection result normal?

YES >> INSPECTION END

NO >> Replace engine coolant temperature sensor.

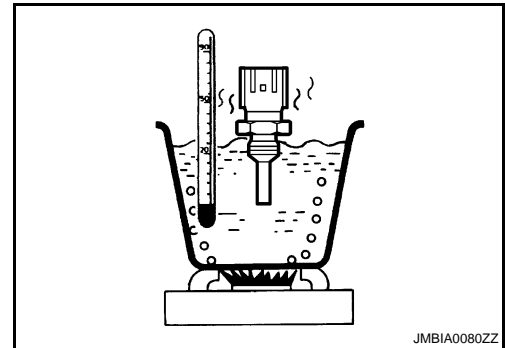

A
EC
C
D
E
F
G
H
I
J
K
L
M
N
O
P

P0130, P0150 A/F SENSOR 1

Description

INFOID:000000003387987

The air fuel ratio (A/F) sensor 1 is a planar one-cell limit current sensor. The sensor element of the A/F sensor 1 is composed an electrode layer, which transports ions. It has a heater in the element. The sensor is capable of precise measurement $\lambda = 1$, but also in the lean and rich range. Together with its control electronics, the sensor outputs a clear, continuous signal throughout a wide λ range. The exhaust gas components diffuse through the diffusion layer at the sensor cell. An electrode layer is applied voltage, and this current relative oxygen density in lean. Also this current relative hydrocarbon density in rich.

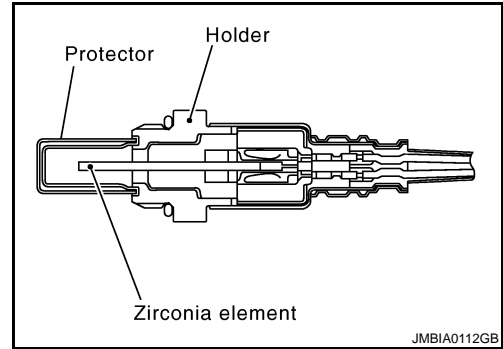

Therefore, the A/F sensor 1 is able to indicate air fuel ratio by this electrode layer of current. In addition, a heater is integrated in the sensor to ensure the required operating temperature of approximately 800°C (1,472°F).

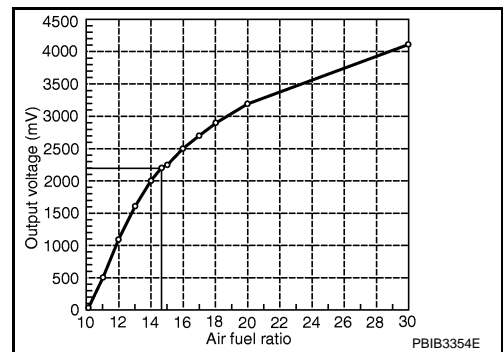

DTC Logic

INFOID:000000003387988

DTC DETECTION LOGIC

To judge malfunctions, the diagnosis checks that the A/F signal computed by ECM from the A/F sensor 1 signal fluctuates according to fuel feedback control.

DTC No.	Trouble diagnosis name	DTC detecting condition		Possible cause
P0130	Air fuel ratio (A/F) sensor 1 (bank 1) circuit	A)	The A/F signal computed by ECM from the A/F sensor 1 signal is constantly in a range other than approx. 2.2 V.	<ul style="list-style-type: none"> • Harness or connectors (The A/F sensor 1 circuit is open or shorted.) • A/F sensor 1
		B)	The A/F signal computed by ECM from the A/F sensor 1 signal is constantly approx. 2.2 V.	
P0150	Air fuel ratio (A/F) sensor 1 (bank 2) circuit	A)	The A/F signal computed by ECM from the A/F sensor 1 signal is constantly in a range other than approx. 2.2 V.	<ul style="list-style-type: none"> • Harness or connectors (The A/F sensor 1 circuit is open or shorted.) • A/F sensor 1
		B)	The A/F signal computed by ECM from the A/F sensor 1 signal is constantly approx. 2.2 V.	

DTC CONFIRMATION PROCEDURE

1. PRECONDITIONING

If DTC Confirmation Procedure has been previously conducted, always perform the following before conducting the next test.

1. Turn ignition switch OFF and wait at least 10 seconds.
2. Turn ignition switch ON.
3. Turn ignition switch OFF and wait at least 10 seconds.

TESTING CONDITION:

Before performing the following procedure, confirm that battery voltage is more than 11 V at idle.

>> GO TO 2.

P0130, P0150 A/F SENSOR 1

< COMPONENT DIAGNOSIS >

[VQ35DE]

2. PERFORM DTC CONFIRMATION PROCEDURE FOR MALFUNCTION A

1. Start engine and warm it up to normal operating temperature.
2. Let engine idle for 2 minutes.
3. Check 1st trip DTC.

Is 1st trip DTC detected?

YES >> Go to [EC-188, "Diagnosis Procedure"](#).

NO-1 >> With CONSULT-III: GO TO 3.

NO-2 >> With GST: GO TO 7.

3. CHECK AIR FUEL RATIO (A/F) SENSOR 1 FUNCTION

1. Start engine and warm it up to normal operating temperature.
2. Select "A/F SEN1 (B1)" or "A/F SEN1 (B2)" in "DATA MONITOR" mode with CONSULT-III.
3. Check "A/F SEN1 (B1)" or "A/F SEN1 (B2)" indication.

Does the indication fluctuate around 2.2 V?

YES >> GO TO 4.

NO >> Go to [EC-188, "Diagnosis Procedure"](#).

4. PERFORM DTC CONFIRMATION PROCEDURE FOR MALFUNCTION B-I

1. Select "A/F SEN1 (B1) P1276" (for DTC P0130) or "A/F SEN1 (B2) P1286" (for DTC P0150) of "A/F SEN1" in "DTC WORK SUPPORT" mode with CONSULT-III.
2. Touch "START".
3. When the following conditions are met, "TESTING" will be displayed on the CONSULT-III screen.

ENG SPEED	1,000 - 3,200 rpm
VHCL SPEED SE	More than 64 km/h (40 mph)
B/FUEL SCHDL	1.0 - 8.0 msec
Selector lever	D position

If "TESTING" is not displayed after 20 seconds, retry from step 2.

CAUTION:

Always drive vehicle at a safe speed.

Is "TESTING" displayed on CONSULT-III screen?

YES >> GO TO 5.

NO >> Check A/F sensor 1 function again. GO TO 3.

5. PERFORM DTC CONFIRMATION PROCEDURE FOR MALFUNCTION B-II

Release accelerator pedal fully.

NOTE:

Never apply brake when releasing the accelerator pedal.

Which does "TESTING" change to?

COMPLETED>>GO TO 6.

OUT OF CONDITION>>Retry DTC CONFIRMATION PROCEDURE. GO TO 4.

6. PERFORM DTC CONFIRMATION PROCEDURE FOR MALFUNCTION B-III

Touch "SELF-DIAG RESULT".

Which is displayed on CONSULT-III screen?

OK >> INSPECTION END

NG >> Go to [EC-188, "Diagnosis Procedure"](#).

7. PERFORM COMPONENT FUNCTION CHECK FOR MALFUNCTION B

Perform component function check. Refer to [EC-188, "Component Function Check"](#).

NOTE:

Use component function check to check the overall function of the A/F sensor 1 circuit. During this check, a 1st trip DTC might not be confirmed.

Is the inspection result normal?

YES >> INSPECTION END

P0130, P0150 A/F SENSOR 1

[VQ35DE]

< COMPONENT DIAGNOSIS >

NO >> Go to [EC-188. "Diagnosis Procedure"](#).

Component Function Check

INFOID:000000003387989

1.PERFORM COMPONENT FUNCTION CHECK

With GST

1. Start engine and warm it up to normal operating temperature.
2. Drive the vehicle at a speed of 80 km/h (50 MPH) for a few minutes in the suitable gear position.
3. Shift the selector lever to the D position, then release the accelerator pedal fully until the vehicle speed decreases to 50 km/h (31 MPH).

CAUTION:

Always drive vehicle at a safe speed.

NOTE:

Never apply brake when releasing the accelerator pedal.

4. Repeat steps 2 and 3 for 5 times.
5. Stop the vehicle and turn ignition switch OFF.
6. Wait at least 10 seconds and restart engine.
7. Repeat steps 2 and 3 for 5 times.
8. Stop the vehicle.
9. Check 1st trip DTC.

Is 1st trip DTC detected?

YES >> Go to [EC-188. "Diagnosis Procedure"](#).

NO >> INSPECTION END

Diagnosis Procedure

INFOID:000000003387990

1.CHECK GROUND CONNECTION

1. Turn ignition switch OFF.
2. Check ground connection E38. Refer to Ground Inspection in [GI-43. "Circuit Inspection"](#).

Is the inspection result normal?

YES >> GO TO 2.

NO >> Repair or replace ground connection.

2.CHECK AIR FUEL RATIO (A/F) SENSOR 1 POWER SUPPLY CIRCUIT

1. Disconnect A/F sensor 1 harness connector.
2. Turn ignition switch ON.
3. Check the voltage between A/F sensor 1 harness connector and ground.

DTC	A/F sensor 1			Ground	Voltage
	Bank	Connector	Terminal		
P0130	1	F27	4	Ground	Battery voltage
P0150	2	F64	4		

Is the inspection result normal?

YES >> GO TO 4.

NO >> GO TO 3.

3.DETECT MALFUNCTIONING PART

Check the following.

- IPDM E/R harness connector F12
- 15 A fuse (No. 46)
- Harness for open or short between A/F sensor 1 and IPDM E/R

>> Repair or replace harness or connectors.

4.CHECK A/F SENSOR 1 INPUT SIGNAL CIRCUIT FOR OPEN AND SHORT

1. Turn ignition switch OFF.
2. Disconnect ECM harness connector.

P0130, P0150 A/F SENSOR 1

[VQ35DE]

< COMPONENT DIAGNOSIS >

3. Check the continuity between A/F sensor 1 harness connector and ECM harness connector.

DTC	A/F sensor 1			ECM		Continuity
	Bank	Connector	Terminal	Connector	Terminal	
P0130	1	F27	1	F8	45	Existed
			2		49	
P0150	2	F64	1		53	
			2		57	

4. Check the continuity between A/F sensor 1 harness connector and ground, or ECM harness connector and ground.

DTC	A/F sensor 1			Ground	Continuity
	Bank	Connector	Terminal		
P0130	1	F27	1	Ground	Not existed
			2		
P0150	2	F64	1		
			2		

DTC	ECM		Ground	Continuity
	Connector	Terminal		
P0130	F8	45	Ground	Not existed
		49		
P0150		53		
		57		

5. Also check harness for short to power.

Is the inspection result normal?

YES >> GO TO 5.

NO >> Repair open circuit, short to ground or short to power in harness or connectors.

5.CHECK INTERMITTENT INCIDENT

Perform [GI-40. "Intermittent Incident"](#).

Is the inspection result normal?

YES >> GO TO 6.

NO >> Repair or replace malfunctioning part.

6.REPLACE AIR FUEL RATIO (A/F) SENSOR 1

Replace malfunctioning air fuel ratio (A/F) sensor 1.

CAUTION:

- Discard any A/F sensor which has been dropped from a height of more than 0.5 m (19.7 in) onto a hard surface such as a concrete floor; use a new one.
- Before installing new A/F sensor, clean exhaust system threads using Oxygen Sensor Thread Cleaner [commercial service tool (J-43897-18 or J-43897-12)] and approved anti-seize lubricant (commercial service tool).

>> INSPECTION END

P0131, P0151 A/F SENSOR 1

Description

INFOID:000000003591590

The air fuel ratio (A/F) sensor 1 is a planar one-cell limit current sensor. The sensor element of the A/F sensor 1 is composed an electrode layer, which transports ions. It has a heater in the element. The sensor is capable of precise measurement $\lambda = 1$, but also in the lean and rich range. Together with its control electronics, the sensor outputs a clear, continuous signal throughout a wide λ range. The exhaust gas components diffuse through the diffusion layer at the sensor cell. An electrode layer is applied voltage, and this current relative oxygen density in lean. Also this current relative hydrocarbon density in rich.

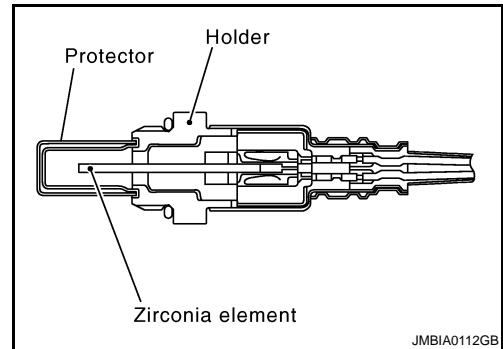

Therefore, the A/F sensor 1 is able to indicate air fuel ratio by this electrode layer of current. In addition, a heater is integrated in the sensor to ensure the required operating temperature of approximately 800°C (1,472°F).

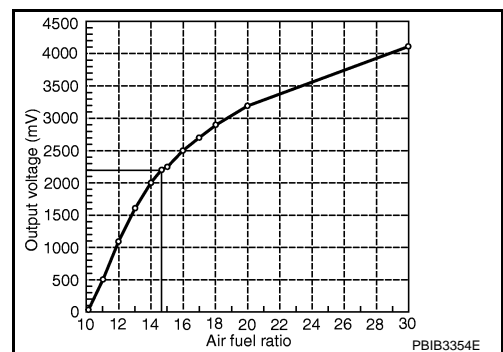

DTC Logic

INFOID:000000003387992

DTC DETECTION LOGIC

To judge the malfunction, the diagnosis checks that the A/F signal computed by ECM from the A/F sensor 1 signal is not inordinately low.

DTC No.	Trouble diagnosis name	DTC detecting condition	Possible cause
P0131	Air fuel ratio (A/F) sensor 1 (bank 1) circuit low voltage	<ul style="list-style-type: none"> The A/F signal computed by ECM from the A/F sensor 1 signal is constantly approx. 0 V. 	<ul style="list-style-type: none"> Harness or connectors (The A/F sensor 1 circuit is open or shorted.) A/F sensor 1
P0151	Air fuel ratio (A/F) sensor 1 (bank 2) circuit low voltage		

DTC CONFIRMATION PROCEDURE

1. PRECONDITIONING

If DTC Confirmation Procedure has been previously conducted, always perform the following before conducting the next test.

1. Turn ignition switch OFF and wait at least 10 seconds.
2. Turn ignition switch ON.
3. Turn ignition switch OFF and wait at least 10 seconds.

TESTING CONDITION:

Before performing the following procedure, confirm that battery voltage is more than 10.5 V at idle.

>> GO TO 2.

2. CHECK A/F SENSOR 1 FUNCTION

With CONSULT-III

1. Start engine and warm it up to normal operating temperature.
2. Select "A/F SEN1 (B1)" or "A/F SEN1 (B2)" in "DATA MONITOR" mode with CONSULT-III.
3. Check "A/F SEN1 (B1)" or "A/F SEN1 (B2)" indication.

P0131, P0151 A/F SENSOR 1

[VQ35DE]

< COMPONENT DIAGNOSIS >

With GST

Follow the procedure "With CONSULT-III" above.

Is the indication constantly approx. 0 V?

- YES >> Go to [EC-191. "Diagnosis Procedure"](#).
- NO >> GO TO 3.

3.PERFORM DTC CONFIRMATION PROCEDURE

With CONSULT-III

1. Turn ignition switch OFF, wait at least 10 seconds.
2. Turn ignition switch ON.
3. Turn ignition switch OFF, wait at least 10 seconds and then restart engine.
4. Drive and accelerate vehicle to more than 40 km/h (25 MPH) within 20 seconds after restarting engine.

CAUTION:

Always drive vehicle at a safe speed.

5. Maintain the following conditions for approximately 20 consecutive seconds.

ENG SPEED	1,000 - 3,200 rpm
VHCL SPEED SE	More than 40 km/h (25 mph)
B/FUEL SCHDL	1.5 - 9.0 msec
Selector lever	Suitable position

NOTE:

- Keep the accelerator pedal as steady as possible during cruising.
- If this procedure is not completed within 1 minute after restarting engine at step 1, return to step 1.

6. Check 1st trip DTC.

With GST

Follow the procedure "With CONSULT-III" above.

Is 1st trip DTC detected?

- YES >> Go to [EC-191. "Diagnosis Procedure"](#).
- NO >> INSPECTION END

Diagnosis Procedure

INFOID:000000003387993

1.CHECK GROUND CONNECTION

1. Turn ignition switch OFF.
2. Check ground connection E38. Refer to Ground Inspection in [GI-43. "Circuit Inspection"](#).

Is the inspection result normal?

- YES >> GO TO 2.
- NO >> Repair or replace ground connection.

2.CHECK AIR FUEL RATIO (A/F) SENSOR 1 POWER SUPPLY CIRCUIT

1. Disconnect A/F sensor 1 harness connector.
2. Turn ignition switch ON.
3. Check the voltage between A/F sensor 1 harness connector and ground.

DTC	A/F sensor 1			Ground	Voltage
	Bank	Connector	Terminal		
P0131	1	F27	4	Ground	Battery voltage
P0151	2	F64	4		

Is the inspection result normal?

- YES >> GO TO 4.
- NO >> GO TO 3.

3.DETECT MALFUNCTIONING PART

Check the following.

P0131, P0151 A/F SENSOR 1

[VQ35DE]

< COMPONENT DIAGNOSIS >

- IPDM E/R harness connector F12
- 15 A fuse (No. 46)
- Harness for open or short between A/F sensor 1 and IPDM E/R

>> Repair or replace harness or connectors.

4. CHECK A/F SENSOR 1 INPUT SIGNAL CIRCUIT FOR OPEN AND SHORT

1. Turn ignition switch OFF.
2. Disconnect ECM harness connector.
3. Check the continuity between A/F sensor 1 harness connector and ECM harness connector.

DTC	A/F sensor 1			ECM		Continuity
	Bank	Connector	Terminal	Connector	Terminal	
P0131	1	F27	1	F8	45	Existed
			2		49	
P0151	2	F64	1		53	
			2		57	

4. Check the continuity between A/F sensor 1 harness connector and ground, or ECM harness connector and ground.

DTC	A/F sensor 1			Ground	Continuity
	Bank	Connector	Terminal		
P0131	1	F27	1	Ground	Not existed
			2		
P0151	2	F64	1		
			2		

DTC	ECM		Ground	Continuity
	Connector	Terminal		
P0131	F8	45	Ground	Not existed
		49		
53				
57				
P0151				

5. Also check harness for short to power.

Is the inspection result normal?

YES >> GO TO 5.

NO >> Repair open circuit, short to ground or short to power in harness or connectors.

5. CHECK INTERMITTENT INCIDENT

Perform [GI-40. "Intermittent Incident"](#).

Is the inspection result normal?

YES >> GO TO 6.

NO >> Repair or replace malfunctioning part.

6. REPLACE AIR FUEL RATIO (A/F) SENSOR 1

Replace malfunctioning air fuel ratio (A/F) sensor 1.

CAUTION:

- Discard any A/F sensor which has been dropped from a height of more than 0.5 m (19.7 in) onto a hard surface such as a concrete floor; use a new one.
- Before installing new A/F sensor, clean exhaust system threads using Oxygen Sensor Thread Cleaner [commercial service tool (J-43897-18 or J-43897-12)] and approved anti-seize lubricant (commercial service tool).

P0131, P0151 A/F SENSOR 1

< COMPONENT DIAGNOSIS >

[VQ35DE]

>> INSPECTION END

A

EC

C

D

E

F

G

H

I

J

K

L

M

N

O

P

P0132, P0152 A/F SENSOR 1

Description

INFOID:000000003591591

The air fuel ratio (A/F) sensor 1 is a planar one-cell limit current sensor. The sensor element of the A/F sensor 1 is composed an electrode layer, which transports ions. It has a heater in the element. The sensor is capable of precise measurement $\lambda = 1$, but also in the lean and rich range. Together with its control electronics, the sensor outputs a clear, continuous signal throughout a wide λ range. The exhaust gas components diffuse through the diffusion layer at the sensor cell. An electrode layer is applied voltage, and this current relative oxygen density in lean. Also this current relative hydrocarbon density in rich.

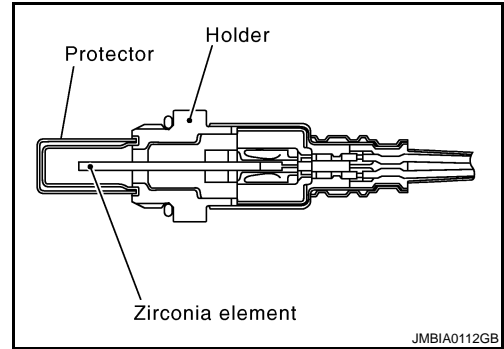

Therefore, the A/F sensor 1 is able to indicate air fuel ratio by this electrode layer of current. In addition, a heater is integrated in the sensor to ensure the required operating temperature of approximately 800°C (1,472°F).

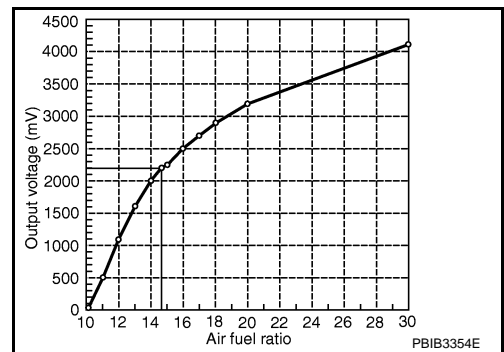

DTC Logic

INFOID:000000003387995

DTC DETECTION LOGIC

To judge the malfunction, the diagnosis checks that the A/F signal computed by ECM from the A/F sensor 1 signal is not inordinately high.

DTC No.	Trouble diagnosis name	DTC detecting condition	Possible cause
P0132	Air fuel ratio (A/F) sensor 1 (bank 1) circuit high voltage	<ul style="list-style-type: none"> The A/F signal computed by ECM from the A/F sensor 1 signal is constantly approx. 5 V. 	<ul style="list-style-type: none"> Harness or connectors (The A/F sensor 1 circuit is open or shorted.) A/F sensor 1
P0152	Air fuel ratio (A/F) sensor 1 (bank 2) circuit high voltage		

DTC CONFIRMATION PROCEDURE

1. PRECONDITIONING

If DTC Confirmation Procedure has been previously conducted, always preform the following before conducting the next test.

1. Turn ignition switch OFF and wait at least 10 seconds.
2. Turn ignition switch ON.
3. Turn ignition switch OFF and wait at least 10 seconds.

TESTING CONDITION:

Before performing the following procedure, confirm that battery voltage is more than 10.5 V at idle.

>> GO TO 2.

2. CHECK A/F SENSOR 1 FUNCTION

ⓐ With CONSULT-III

1. Start engine and warm it up to normal operating temperature.
2. Select "A/F SEN1 (B1)" or "A/F SEN1 (B2)" in "DATA MONITOR" mode with CONSULT-III.
3. Check "A/F SEN1 (B1)" or "A/F SEN1 (B2)" indication.

< COMPONENT DIAGNOSIS >

 **With GST**

Follow the procedure "With CONSULT-III" above.

Is the indication constantly approx. 5 V?

- YES >> Go to [EC-195. "Diagnosis Procedure"](#).
- NO >> GO TO 3.

3. PERFORM DTC CONFIRMATION PROCEDURE

 **With CONSULT-III**

1. Turn ignition switch OFF and wait at least 10 seconds.
2. Turn ignition switch ON.
3. Turn ignition switch OFF, wait at least 10 seconds and then restart engine.
4. Drive and accelerate vehicle to more than 40 km/h (25 MPH) within 20 seconds after restarting engine.

CAUTION:

Always drive vehicle at a safe speed.

5. Maintain the following conditions for approximately 20 consecutive seconds.

ENG SPEED	1,000 - 3,200 rpm
VHCL SPEED SE	More than 40 km/h (25 mph)
B/FUEL SCHDL	1.5 - 9.0 msec
Selector lever	Suitable position

NOTE:

- Keep the accelerator pedal as steady as possible during cruising.
- If this procedure is not completed within 1 minute after restarting engine at step 1, return to step 1.

6. Check 1st trip DTC.

 **With GST**

Follow the procedure "With CONSULT-III" above.

Is 1st trip DTC detected?

- YES >> Go to [EC-195. "Diagnosis Procedure"](#).
- NO >> INSPECTION END

Diagnosis Procedure

INFOID:000000003387996

1. CHECK GROUND CONNECTION

1. Turn ignition switch OFF.
2. Check ground connection E38. Refer to Ground Inspection in [GI-43. "Circuit Inspection"](#).

Is the inspection result normal?

- YES >> GO TO 2.
- NO >> Repair or replace ground connection.

2. CHECK AIR FUEL RATIO (A/F) SENSOR 1 POWER SUPPLY CIRCUIT

1. Disconnect A/F sensor 1 harness connector.
2. Turn ignition switch ON.
3. Check the voltage between A/F sensor 1 harness connector and ground.

DTC	A/F sensor 1			Ground	Voltage
	Bank	Connector	Terminal		
P0132	1	F27	4	Ground	Battery voltage
P0152	2	F64	4		

Is the inspection result normal?

- YES >> GO TO 4.
- NO >> GO TO 3.

3. DETECT MALFUNCTIONING PART

Check the following.

A
EC
C
D
E
F
G
H
I
J
K
L
M
N
O
P

P0132, P0152 A/F SENSOR 1

[VQ35DE]

< COMPONENT DIAGNOSIS >

- IPDM E/R harness connector F12
- 15 A fuse (No. 46)
- Harness for open or short between A/F sensor 1 and IPDM E/R

>> Repair or replace harness or connectors.

4. CHECK A/F SENSOR 1 INPUT SIGNAL CIRCUIT FOR OPEN AND SHORT

1. Turn ignition switch OFF.
2. Disconnect ECM harness connector.
3. Check the continuity between A/F sensor 1 harness connector and ECM harness connector.

DTC	A/F sensor 1			ECM		Continuity
	Bank	Connector	Terminal	Connector	Terminal	
P0132	1	F27	1	F8	45	Existed
			2		49	
P0152	2	F64	1		53	
			2		57	

4. Check the continuity between A/F sensor 1 harness connector and ground, or ECM harness connector and ground.

DTC	A/F sensor 1			Ground	Continuity
	Bank	Connector	Terminal		
P0132	1	F27	1	Ground	Not existed
			2		
P0152	2	F64	1		
			2		

DTC	ECM		Ground	Continuity
	Connector	Terminal		
P0132	F8	45	Ground	Not existed
		49		
P0152		53		
		57		

5. Also check harness for short to power.

Is the inspection result normal?

YES >> GO TO 5.

NO >> Repair open circuit, short to ground or short to power in harness or connectors.

5. CHECK INTERMITTENT INCIDENT

Perform [GI-40. "Intermittent Incident"](#).

Is the inspection result normal?

YES >> GO TO 6.

NO >> Repair or replace malfunctioning part.

6. REPLACE AIR FUEL RATIO (A/F) SENSOR 1

Replace malfunctioning air fuel ratio (A/F) sensor 1.

CAUTION:

- Discard any A/F sensor which has been dropped from a height of more than 0.5 m (19.7 in) onto a hard surface such as a concrete floor; use a new one.
- Before installing new A/F sensor, clean exhaust system threads using Oxygen Sensor Thread Cleaner [commercial service tool (J-43897-18 or J-43897-12)] and approved anti-seize lubricant (commercial service tool).

P0132, P0152 A/F SENSOR 1

< COMPONENT DIAGNOSIS >

[VQ35DE]

>> INSPECTION END

A

EC

C

D

E

F

G

H

I

J

K

L

M

N

O

P

P0133, P0153 A/F SENSOR 1

Description

INFOID:000000003591592

The air fuel ratio (A/F) sensor 1 is a planar one-cell limit current sensor. The sensor element of the A/F sensor 1 is composed an electrode layer, which transports ions. It has a heater in the element. The sensor is capable of precise measurement $\lambda = 1$, but also in the lean and rich range. Together with its control electronics, the sensor outputs a clear, continuous signal throughout a wide λ range. The exhaust gas components diffuse through the diffusion layer at the sensor cell. An electrode layer is applied voltage, and this current relative oxygen density in lean. Also this current relative hydrocarbon density in rich.

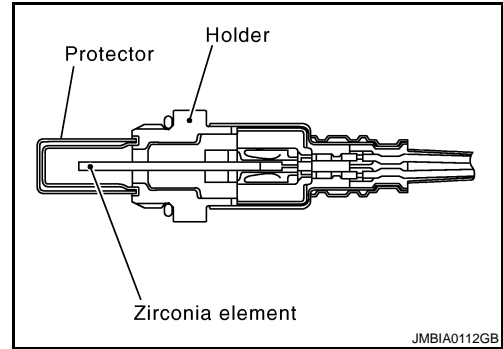

Therefore, the A/F sensor 1 is able to indicate air fuel ratio by this electrode layer of current. In addition, a heater is integrated in the sensor to ensure the required operating temperature of approximately 800°C (1,472°F).

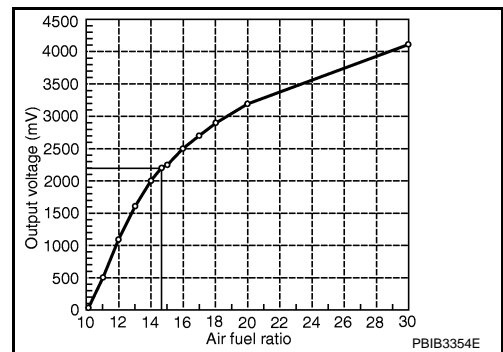

DTC Logic

INFOID:0000000003387998

DTC DETECTION LOGIC

To judge the malfunction of A/F sensor 1, this diagnosis measures response time of the A/F signal computed by ECM from the A/F sensor 1 signal. The time is compensated by engine operating (speed and load), fuel feedback control constant, and the A/F sensor 1 temperature index. Judgment is based on whether the compensated time (the A/F signal cycling time index) is inordinately long or not.

DTC No.	Trouble diagnosis name	DTC detecting condition	Possible cause
P0133	Air fuel ratio (A/F) sensor 1 (bank 1) circuit slow response	<ul style="list-style-type: none"> The response of the A/F signal computed by ECM from A/F sensor 1 signal takes more than the specified time. 	<ul style="list-style-type: none"> Harness or connectors (The A/F sensor 1 circuit is open or shorted.) A/F sensor 1 A/F sensor 1 heater Fuel pressure Fuel injector Intake air leakage Exhaust gas leakage PCV Mass air flow sensor
P0153	Air fuel ratio (A/F) sensor 1 (bank 2) circuit slow response		

DTC CONFIRMATION PROCEDURE

1. PRECONDITIONING

If DTC Confirmation Procedure has been previously conducted, always perform the following before conducting the next test.

1. Turn ignition switch OFF and wait at least 10 seconds.
2. Turn ignition switch ON.
3. Turn ignition switch OFF and wait at least 10 seconds.

TESTING CONDITION:

Before performing the following procedure, confirm that battery voltage is more than 11 V at idle.

Will CONSULT-III be used?

< COMPONENT DIAGNOSIS >

- YES >> GO TO 2.
NO >> GO TO 5.

2.PERFORM DTC CONFIRMATION PROCEDURE-I

 With CONSULT-III

1. Start engine and warm it up to normal operating temperature.
2. Turn ignition switch OFF and wait at least 10 seconds.
3. Turn ignition switch ON.
4. Turn ignition switch OFF and wait at least 10 seconds.
5. Start engine and keep the engine speed between 3,500 and 4,000 rpm for at least 1 minute under no load.
6. Let engine idle for 1 minute.
7. Select "A/F SEN1(B1) P1278/P1279" (for DTC P0133) or "A/F SEN1(B2) P1288/P1289" (for DTC P0153) of "A/F SEN1" in "DTC WORK SUPPORT" mode with CONSULT-III.
8. Touch "START".

Is COMPLETED displayed?

- YES >> GO TO 3.
NO >> GO TO 4.

3.PERFORM DTC CONFIRMATION PROCEDURE-II

Check that "OK" is displayed after touching "SELF-DIAG RESULT".

Is OK displayed?

- YES >> INSPECTION END
NO >> Go to [EC-200. "Diagnosis Procedure"](#).

4.PERFORM DTC CONFIRMATION PROCEDURE-III

1. After perform the following procedure, "TESTING" will be displayed on the CONSULT-III screen.
 - Increase the engine speed up to between 4,000 and 5,000 rpm and maintain that speed for 10 seconds.
 - Fully release accelerator pedal and then let engine idle for approximately 10 seconds.

If "TESTING" is not displayed after 10 seconds, go to [EC-127. "Component Function Check"](#).
2. Wait for approximately 20 seconds idle under the condition that "TESTING" is displayed on the CONSULT-III screen.
3. Check that "TESTING" changes to "COMPLETED".
If "TESTING" changed to "OUT OF CONDITION", go to [EC-127. "Component Function Check"](#).
4. Check that "OK" is displayed after touching "SELF-DIAG RESULT".

Is OK displayed?

- YES >> INSPECTION END
NO >> Go to [EC-200. "Diagnosis Procedure"](#).

5.CHECK MIXTURE RATIO SELF-LEARNING VALUE

 With GST

1. Start engine and warm it up to normal operating temperature.
2. Select Service \$01 with GST.
3. Calculate the total value of "Short term fuel trim" and "Long term fuel trim" indications.

Is the total percentage within $\pm 15\%$?

- YES >> GO TO 7.
NO >> GO TO 6.

6.DETECT MALFUNCTIONING PART

Check the following.

- Intake air leakage
- Exhaust gas leakage
- Incorrect fuel pressure
- Lack of fuel
- Fuel injector
- Incorrect PCV hose connection
- PCV valve
- Mass air flow sensor

< COMPONENT DIAGNOSIS >

>> Repair or replace malfunctioning part.

7. PERFORM DTC CONFIRMATION PROCEDURE-IV

1. Turn ignition switch OFF and wait at least 10 seconds.
2. Turn ignition switch ON.
3. Turn ignition switch OFF and wait at least 10 seconds.
4. Start engine and keep the engine speed between 3,500 and 4,000 rpm for at least 1 minute under no load.
5. Let engine idle for 1 minute.
6. Increase the engine speed up to between 4,000 and 5,000 rpm and maintain that speed for 10 seconds.
7. Fully release accelerator pedal and then let engine idle for approximately 1 minute.
8. Check 1st trip DTC.

Is 1st trip DTC detected?

- YES >> Go to [EC-200, "Diagnosis Procedure"](#).
 NO >> INSPECTION END

Diagnosis Procedure

INFOID:000000003387999

1. CHECK GROUND CONNECTION

1. Turn ignition switch OFF.
2. Check ground connection E38. Refer to Ground Inspection in [GI-43, "Circuit Inspection"](#).

Is the inspection result normal?

- YES >> GO TO 2.
 NO >> Repair or replace ground connection.

2. RETIGHTEN A/F SENSOR 1

Loosen and retighten the A/F sensor 1. Refer to [EM-34, "Removal and Installation"](#).

>> GO TO 3.

3. CHECK EXHAUST GAS LEAKAGE

1. Start engine and run it at idle.
2. Listen for an exhaust gas leakage before three way catalyst (manifold).

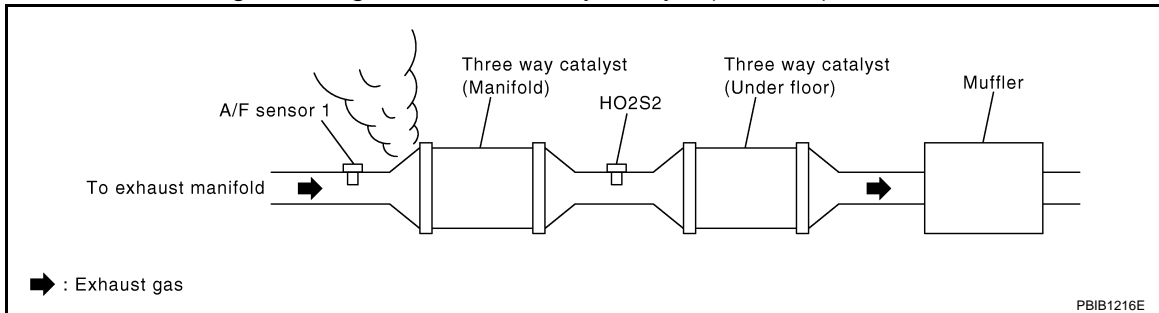

Is exhaust gas leakage detected?

- YES >> Repair or replace malfunctioning part.
 NO >> GO TO 4.

4. CHECK FOR INTAKE AIR LEAKAGE

Listen for an intake air leakage after the mass air flow sensor.

Is intake air leakage detected?

- YES >> Repair or replace malfunctioning part.
 NO >> GO TO 5.

5. CLEAR MIXTURE RATIO SELF-LEARNING VALUE

1. Clear the mixture ratio self-learning value. Refer to [EC-19, "MIXTURE RATIO SELF-LEARNING VALUE CLEAR : Special Repair Requirement"](#).
2. Run engine for at least 10 minutes at idle speed.
3. Check 1st trip DTC.

Is the 1st trip DTC P0171, P0172, P0174 or P0175 detected? Is it difficult to start engine?

P0133, P0153 A/F SENSOR 1

[VQ35DE]

< COMPONENT DIAGNOSIS >

- YES >> Perform trouble diagnosis for DTC P0171, P0174 or P0172, P0175. Refer to [EC-226. "DTC Logic"](#) or [EC-231. "DTC Logic"](#).
- NO >> GO TO 6.

6. CHECK AIR FUEL RATIO (A/F) SENSOR 1 POWER SUPPLY CIRCUIT

1. Turn ignition switch OFF.
2. Disconnect A/F sensor 1 harness connector.
3. Turn ignition switch ON.
4. Check the voltage between A/F sensor 1 harness connector and ground.

DTC	A/F sensor 1			Ground	Voltage
	Bank	Connector	Terminal		
P0133	1	F27	4	Ground	Battery voltage
P0153	2	F64	4		

Is the inspection result normal?

- YES >> GO TO 8.
NO >> GO TO 7.

7. DETECT MALFUNCTIONING PART

Check the following.

- IPDM E/R harness connector F12
- 15 A fuse (No. 46)
- Harness for open or short between A/F sensor 1 and IPDM E/R

>> Repair or replace harness or connectors.

8. CHECK A/F SENSOR 1 INPUT SIGNAL CIRCUIT FOR OPEN AND SHORT

1. Turn ignition switch OFF.
2. Disconnect ECM harness connector.
3. Check the continuity between A/F sensor 1 harness connector and ECM harness connector.

DTC	A/F sensor 1			ECM		Continuity
	Bank	Connector	Terminal	Connector	Terminal	
P0133	1	F27	1	F8	45	Existed
			2		49	
P0153	2	F64	1		53	
			2		57	

4. Check the continuity between A/F sensor 1 harness connector and ground, or ECM harness connector ground.

DTC	A/F sensor 1			Ground	Continuity
	Bank	Connector	Terminal		
P0133	1	F27	1	Ground	Not existed
			2		
P0153	2	F64	1		
			2		

P0133, P0153 A/F SENSOR 1

[VQ35DE]

< COMPONENT DIAGNOSIS >

DTC	ECM		Ground	Continuity
	Connector	Terminal		
P0133	F8	45	Ground	Not existed
		49		
P0153		53		
		57		

5. Also check harness for short to power.

Is the inspection result normal?

YES >> GO TO 9.

NO >> Repair open circuit, short to ground or short to power in harness or connectors.

9. CHECK AIR FUEL RATIO (A/F) SENSOR 1 HEATER

Refer to [EC-147, "Component Inspection"](#).

Is the inspection result normal?

YES >> GO TO 10.

NO >> GO TO 13.

10. CHECK MASS AIR FLOW SENSOR

Refer to [EC-159, "Component Inspection"](#).

Is the inspection result normal?

YES >> GO TO 11.

NO >> Replace mass air flow sensor.

11. CHECK PCV VALVE

Refer to [EC-462, "Component Inspection"](#).

Is the inspection result normal?

YES >> GO TO 12.

NO >> Repair or replace PCV valve.

12. CHECK INTERMITTENT INCIDENT

Perform [GI-40, "Intermittent Incident"](#).

Is the inspection result normal?

YES >> GO TO 13.

NO >> Repair or replace malfunctioning part.

13. REPLACE AIR FUEL RATIO (A/F) SENSOR 1

Replace malfunctioning air fuel ratio (A/F) sensor 1.

CAUTION:

- Discard any A/F sensor which has been dropped from a height of more than 0.5 m (19.7 in) onto a hard surface such as a concrete floor; use a new one.
- Before installing new A/F sensor, clean exhaust system threads using Oxygen Sensor Thread Cleaner [commercial service tool (J-43897-18 or J-43897-12)] and approved anti-seize lubricant (commercial service tool).

>> INSPECTION END

P0137, P0157 HO2S2

Description

INFOID:000000003388000

The heated oxygen sensor 2, after three way catalyst (manifold), monitors the oxygen level in the exhaust gas on each bank. Even if switching characteristics of the air fuel ratio (A/F) sensor 1 are shifted, the air-fuel ratio is controlled to stoichiometric, by the signal from the heated oxygen sensor 2. This sensor is made of ceramic zirconia. The zirconia generates voltage from approximately 1 V in richer conditions to 0 V in leaner conditions. Under normal conditions the heated oxygen sensor 2 is not used for engine control operation.

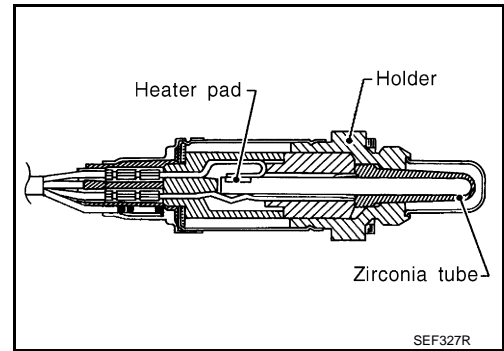

DTC Logic

INFOID:000000003388001

DTC DETECTION LOGIC

The heated oxygen sensor 2 has a much longer switching time between rich and lean than the air fuel ratio (A/F) sensor 1. The oxygen storage capacity of the three way catalyst (manifold) causes the longer switching time. To judge the malfunctions of heated oxygen sensor 2, ECM monitors whether the maximum voltage of the sensor is sufficiently high during various driving conditions such as fuel-cut.

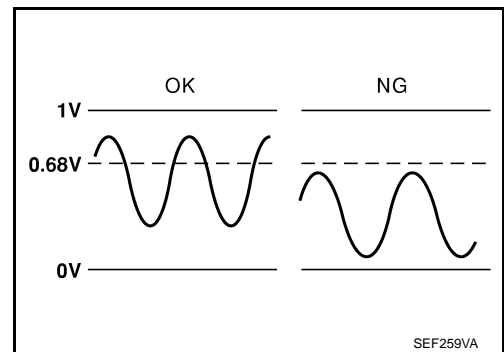

DTC No.	Trouble diagnosis name	DTC detecting condition	Possible cause
P0137	Heated oxygen sensor 2 (bank 1) circuit low voltage	The maximum voltage from the sensor does not reach the specified voltage.	<ul style="list-style-type: none"> • Harness or connectors (The sensor circuit is open or shorted) • Heated oxygen sensor 2 • Fuel pressure • Fuel injector • Intake air leakage
P0157	Heated oxygen sensor 2 (bank 2) circuit low voltage		

DTC CONFIRMATION PROCEDURE

1.INSPECTION START

Will CONSULT-III be used?

Will CONSULT-III be used?

YES >> GO TO 2.

NO >> GO TO 5.

2.PRECONDITIONING

If DTC confirmation Procedure has been previously conducted, always perform the following before conducting the next test.

1. Turn ignition switch OFF and wait at least 10 seconds.
2. Turn ignition switch ON.
3. Turn ignition switch OFF and wait at least 10 seconds.

TESTING CONDITION:

For better results, perform "DTC WORK SUPPORT" at a temperature of 0 to 30°C (32 to 86°F).

>> GO TO 3.

3. PERFORM DTC CONFIRMATION PROCEDURE**④ With CONSULT-III**

1. Turn ignition switch ON and select "DATA MONITOR" mode with CONSULT-III.
2. Start engine and warm it up to the normal operating temperature.
3. Turn ignition switch OFF and wait at least 10 seconds.
4. Turn ignition switch ON.
5. Turn ignition switch OFF and wait at least 10 seconds.
6. Start engine and keep the engine speed between 3,500 and 4,000 rpm for at least 1 minute under no load.
7. Let engine idle for 1 minute.
8. Check that "COOLAN TEMP/S" indicates more than 70°C (158°F).
If not, warm up engine and go to next step when "COOLAN TEMP/S" indication reaches 70°C (158°F).
9. Open engine hood.
10. Select "HO2S2 (B1) P1147" (for DTC P0137) or "HO2S2 (B2) P1167" (for DTC P0157) of "HO2S2" in "DTC WORK SUPPORT" mode with CONSULT-III.
11. Follow the instruction of CONSULT-III display.

NOTE:

It will take at most 10 minutes until "COMPLETED" is displayed.

12. Touch "SELF-DIAG RESULTS".

Which is displayed on CONSULT-III screen?

- OK >> INSPECTION END
 NG >> Go to [EC-205, "Diagnosis Procedure"](#).
 CAN NOT BE DIAGNOSED>>GO TO 4.

4. PERFORM DTC CONFIRMATION PROCEDURE AGAIN

1. Turn ignition switch OFF and leave the vehicle in a cool place (soak the vehicle).
2. Perform DTC confirmation procedure again.

>> GO TO 3.

5. PERFORM COMPONENT FUNCTION CHECK

Perform component function check. Refer to [EC-204, "Component Function Check"](#).

NOTE:

Use component function check to check the overall function of the heated oxygen sensor 2 circuit. During this check, a 1st trip DTC might not be confirmed.

Is the inspection result normal?

- YES >> INSPECTION END
 NO >> Go to [EC-205, "Diagnosis Procedure"](#).

Component Function Check

INFOID:000000003388002

1. PERFORM COMPONENT FUNCTION CHECK-I**⊗ Without CONSULT-III**

1. Start engine and warm it up to the normal operating temperature.
2. Turn ignition switch OFF and wait at least 10 seconds.
3. Turn ignition switch ON.
4. Turn ignition switch OFF and wait at least 10 seconds.
5. Start engine and keep the engine speed between 3,500 and 4,000 rpm for at least 1 minute under no load.
6. Let engine idle for 1 minute.
7. Check the voltage between ECM harness connector terminals under the following conditions.

P0137, P0157 HO2S2

< COMPONENT DIAGNOSIS >

[VQ35DE]

DTC	ECM			Condition	Voltage
	Conne- ctor	+	-		
		Terminal	Terminal		
P0137	F8	33 [HO2S2 (bank 1) signal]	35 (Sensor ground)	Reving up to 4,000 rpm under no load at least 10 times	The voltage should be above 0.68 V at least once during this procedure.
P0157		34 [HO2S2 (bank 2) signal]			

Is the inspection result normal?

YES >> INSPECTION END
NO >> GO TO 2.

2.PERFORM COMPONENT FUNCTION CHECK-II

Check the voltage between ECM harness connector terminals under the following conditions.

DTC	ECM			Condition	Voltage
	Conne- ctor	+	-		
		Terminal	Terminal		
P0137	F8	33 [HO2S2 (bank 1) signal]	35 (Sensor ground)	Keeping engine at idle for 10 min- utes	The voltage should be above 0.68 V at least once during this procedure.
P0157		34 [HO2S2 (bank 2) signal]			

Is the inspection result normal?

YES >> INSPECTION END
NO >> GO TO 3.

3.PERFORM COMPONENT FUNCTION CHECK-III

Check the voltage between ECM harness connector terminals under the following conditions.

DTC	ECM			Condition	Voltage
	Conne- ctor	+	-		
		Terminal	Terminal		
P0137	F8	33 [HO2S2 (bank 1) signal]	35 (Sensor ground)	Coasting from 80 km/h (50 MPH) with selector lever in the D position	The voltage should be above 0.68 V at least once during this procedure.
P0157		34 [HO2S2 (bank 2) signal]			

Is the inspection result normal?

YES >> INSPECTION END
NO >> Go to [EC-205. "Diagnosis Procedure"](#).

Diagnosis Procedure

INFOID:000000003388003

1.CHECK GROUND CONNECTION

1. Turn ignition switch OFF.
2. Check ground connection E38. Refer to Ground Inspection in [GI-43. "Circuit Inspection"](#).

Is the inspection result normal?

YES >> GO TO 2.
NO >> Repair or replace ground connection.

< COMPONENT DIAGNOSIS >

2. CLEAR MIXTURE RATIO SELF-LEARNING VALUE

1. Clear the mixture ratio self-learning value. Refer to [EC-19, "MIXTURE RATIO SELF-LEARNING VALUE CLEAR : Special Repair Requirement"](#).
2. Run engine for at least 10 minutes at idle speed.

Is the 1st trip DTC P0171 or P0174 detected? Is it difficult to start engine?

YES >> Perform trouble diagnosis for DTC P0171 or P0174. Refer to [EC-226, "DTC Logic"](#).

NO >> GO TO 3.

3. CHECK HO2S2 GROUND CIRCUIT FOR OPEN AND SHORT

1. Turn ignition switch OFF.
2. Disconnect heated oxygen sensor 2 harness connector.
3. Disconnect ECM harness connector.
4. Check the continuity between heated oxygen sensor 2 (HO2S2) harness connector and ECM harness connector.

DTC	HO2S2			ECM		Continuity
	Bank	Connector	Terminal	Connector	Terminal	
P0137	1	F70	1	F8	35	Existed
P0157	2	F71	1			

5. Also check harness for short to ground and short to power.

Is the inspection result normal?

YES >> GO TO 4.

NO >> Repair open circuit, short to ground or short to power in harness or connectors.

4. CHECK HO2S2 INPUT SIGNAL CIRCUIT FOR OPEN AND SHORT

1. Check the continuity between HO2S2 harness connector and ECM harness connector.

DTC	HO2S2			ECM		Continuity
	Bank	Connector	Terminal	Connector	Terminal	
P0137	1	F70	4	F8	33	Existed
P0157	2	F71	4		34	

2. Check the continuity between HO2S2 harness connector and ground, or ECM harness connector and ground.

DTC	HO2S2			Ground	Continuity
	Bank	Connector	Terminal		
P0137	1	F70	4	Ground	Not existed
P0157	2	F71	4		

DTC	ECM		Ground	Continuity
	Connector	Terminal		
P0137	F8	33	Ground	Not existed
P0157		34		

3. Also check harness for short to power.

Is the inspection result normal?

YES >> GO TO 5.

NO >> Repair open circuit, short to ground or short to power in harness or connectors.

5. CHECK HEATED OXYGEN SENSOR 2

Refer to [EC-207, "Component Inspection"](#).

Is the inspection result normal?

< COMPONENT DIAGNOSIS >

- YES >> GO TO 7.
- NO >> GO TO 6.

6. REPLACE HEATED OXYGEN SENSOR 2

Replace malfunctioning heated oxygen sensor 2.

CAUTION:

- Discard any heated oxygen sensor which has been dropped from a height of more than 0.5 m (19.7 in) onto a hard surface such as a concrete floor; use a new one.
- Before installing new oxygen sensor, clean exhaust system threads using Oxygen Sensor Thread Cleaner [commercial service tool (J-43897-18 or J-43897-12)] and approved anti-seize lubricant (commercial service tool).

>> INSPECTION END

7. CHECK INTERMITTENT INCIDENT

Refer to [GI-40. "Intermittent Incident"](#).

>> INSPECTION END

Component Inspection

INFOID:000000003388004

1. INSPECTION START

Will CONSULT-III be used?

Will CONSULT-III be used?

- YES >> GO TO 2.
- NO >> GO TO 3.

2. CHECK HEATED OXYGEN SENSOR 2

With CONSULT-III

1. Turn ignition switch ON and select "DATA MONITOR" mode with CONSULT-III.
2. Start engine and warm it up to the normal operating temperature.
3. Turn ignition switch OFF and wait at least 10 seconds.
4. Start engine and keep the engine speed between 3,500 and 4,000 rpm for at least 1 minute under no load.
5. Let engine idle for 1 minute.
6. Select "FUEL INJECTION" in "ACTIVE TEST" mode, and select "HO2S2 (B1)/(B2)" as the monitor item with CONSULT-III.
7. Check "HO2S2 (B1)/(B2)" at idle speed when adjusting "FUEL INJECTION" to $\pm 25\%$.

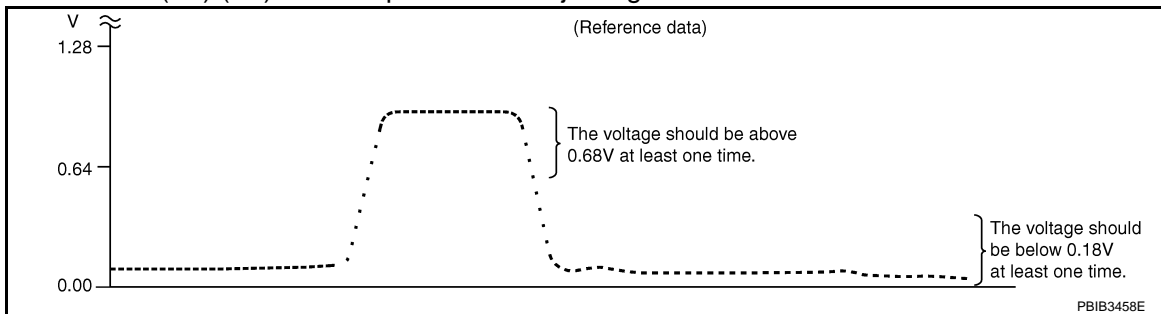

"HO2S2 (B1)/(B2)" should be above 0.68 V at least once when the "FUEL INJECTION" is + 25%.
 "HO2S2 (B1)/(B2)" should be below 0.18 V at least once when the "FUEL INJECTION" is - 25%.

Is the inspection result normal?

- YES >> INSPECTION END
- NO >> GO TO 6.

3. CHECK HEATED OXYGEN SENSOR 2-I

Without CONSULT-III

1. Start engine and warm it up to the normal operating temperature.
2. Turn ignition switch OFF and wait at least 10 seconds.
3. Start engine and keep the engine speed between 3,500 and 4,000 rpm for at least 1 minute under no load.

< COMPONENT DIAGNOSIS >

4. Let engine idle for 1 minute.
5. Check the voltage between ECM harness connector terminals under the following conditions.

ECM			Condition	Voltage
Connector	+	-		
	Terminal	Terminal		
F8	33 [HO2S2 (bank 1) signal]	35 (Sensor ground)	Revving up to 4,000 rpm under no load at least 10 times	The voltage should be above 0.68 V at least once during this procedure. The voltage should be below 0.18 V at least once during this procedure.
	34 [HO2S2 (bank 2) signal]			

Is the inspection result normal?

- YES >> INSPECTION END
NO >> GO TO 4.

4.CHECK HEATED OXYGEN SENSOR 2-II

Check the voltage between ECM harness connector terminals under the following conditions.

ECM			Condition	Voltage
Connector	+	-		
	Terminal	Terminal		
F8	33 [HO2S2 (bank 1) signal]	35 (Sensor ground)	Keeping engine at idle for 10 minutes	The voltage should be above 0.68 V at least once during this procedure. The voltage should be below 0.18 V at least once during this procedure.
	34 [HO2S2 (bank 2) signal]			

Is the inspection result normal?

- YES >> INSPECTION END
NO >> GO TO 5.

5.CHECK HEATED OXYGEN SENSOR 2-III

Check the voltage between ECM harness connector terminals under the following conditions.

ECM			Condition	Voltage
Connector	+	-		
	Terminal	Terminal		
F8	33 [HO2S2 (bank 1) signal]	35 (Sensor ground)	Coasting from 80 km/h (50 MPH) with selector lever in the D position	The voltage should be above 0.68 V at least once during this procedure. The voltage should be below 0.18 V at least once during this procedure.
	34 [HO2S2 (bank 2) signal]			

Is the inspection result normal?

- YES >> INSPECTION END
NO >> GO TO 6.

6.REPLACE HEATED OXYGEN SENSOR 2

Replace malfunctioning heated oxygen sensor 2.

CAUTION:

- Discard any heated oxygen sensor which has been dropped from a height of more than 0.5 m (19.7 in) onto a hard surface such as a concrete floor; use a new one.

P0137, P0157 HO2S2

[VQ35DE]

< COMPONENT DIAGNOSIS >

- Before installing new oxygen sensor, clean exhaust system threads using Oxygen Sensor Thread Cleaner [commercial service tool (J-43897-18 or J-43897-12)] and approved anti-seize lubricant (commercial service tool).

A

>> INSPECTION END

EC

C

D

E

F

G

H

I

J

K

L

M

N

O

P

P0138, P0158 HO2S2

Description

INFOID:000000003591594

The heated oxygen sensor 2, after three way catalyst (manifold), monitors the oxygen level in the exhaust gas on each bank. Even if switching characteristics of the air fuel ratio (A/F) sensor 1 are shifted, the air-fuel ratio is controlled to stoichiometric, by the signal from the heated oxygen sensor 2. This sensor is made of ceramic zirconia. The zirconia generates voltage from approximately 1 V in richer conditions to 0 V in leaner conditions. Under normal conditions the heated oxygen sensor 2 is not used for engine control operation.

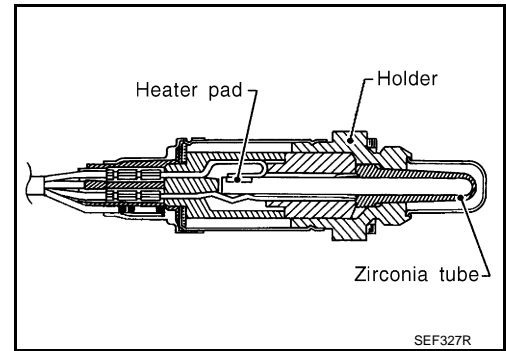

DTC Logic

INFOID:000000003388006

DTC DETECTION LOGIC

The heated oxygen sensor 2 has a much longer switching time between rich and lean than the air fuel ratio (A/F) sensor 1. The oxygen storage capacity of the three way catalyst (manifold) causes the longer switching time.

MALFUNCTION A

To judge the malfunctions of heated oxygen sensor 2, ECM monitors whether the voltage is unusually high during various driving conditions such as fuel cut.

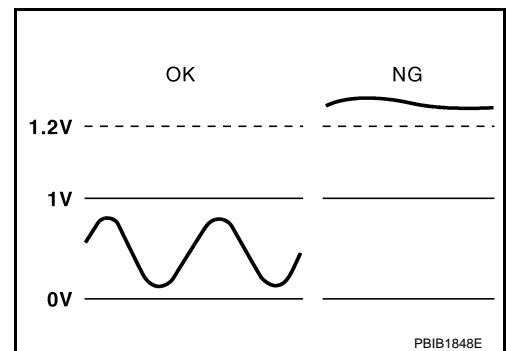

MALFUNCTION B

To judge the malfunctions of heated oxygen sensor 2, ECM monitors whether the minimum voltage of sensor is sufficiently low during various driving conditions such as fuel-cut.

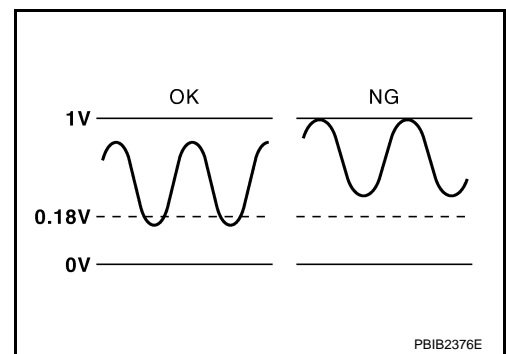

DTC No.	Trouble diagnosis name	DTC detecting condition		Possible cause
P0138	Heated oxygen sensor 2 (bank 1) circuit high voltage	A)	An excessively high voltage from the sensor is sent to ECM.	<ul style="list-style-type: none"> • Harness or connectors (The sensor circuit is open or shorted) • Heated oxygen sensor 2
		B)	The minimum voltage from the sensor is not reached to the specified voltage.	<ul style="list-style-type: none"> • Harness or connectors (The sensor circuit is open or shorted) • Heated oxygen sensor 2 • Fuel pressure • Fuel injector

DTC No.	Trouble diagnosis name	DTC detecting condition		Possible cause
P0158	Heated oxygen sensor 2 (bank 2) circuit high voltage	A)	An excessively high voltage from the sensor is sent to ECM.	<ul style="list-style-type: none"> • Harness or connectors (The sensor circuit is open or shorted) • Heated oxygen sensor 2
		B)	The minimum voltage from the sensor is not reached to the specified voltage.	<ul style="list-style-type: none"> • Harness or connectors (The sensor circuit is open or shorted) • Heated oxygen sensor 2 • Fuel pressure • Fuel injector

DTC CONFIRMATION PROCEDURE

1. PRECONDITIONING

If DTC Confirmation Procedure has been previously conducted, always perform the following before conducting the next test.

1. Turn ignition switch OFF and wait at least 10 seconds.
2. Turn ignition switch ON.
3. Turn ignition switch OFF and wait at least 10 seconds.

>> GO TO 2.

2. PERFORM DTC CONFIRMATION PROCEDURE FOR MALFUNCTION A

1. Start engine and warm it up to the normal operating temperature.
2. Turn ignition switch OFF and wait at least 10 seconds.
3. Turn ignition switch ON.
4. Turn ignition switch OFF and wait at least 10 seconds.
5. Start engine and keep the engine speed between 3,500 and 4,000 rpm for at least 1 minute under no load.
6. Let engine idle for 2 minutes.
7. Check 1st trip DTC.

Is 1st trip DTC detected?

- YES >> Go to [EC-213, "Diagnosis Procedure"](#).
- NO-1 >> With CONSULT-III: GO TO 3.
- NO-2 >> Without CONSULT-III: GO TO 5.

3. PERFORM DTC CONFIRMATION PROCEDURE FOR MALFUNCTION B

NOTE:

For better results, perform "DTC WORK SUPPORT" at a temperature of 0 to 30°C (32 to 86°F).

1. Select "DATA MONITOR" mode with CONSULT-III.
2. Start engine and warm it up to the normal operating temperature.
3. Turn ignition switch OFF and wait at least 10 seconds.
4. Turn ignition switch ON.
5. Turn ignition switch OFF and wait at least 10 seconds.
6. Start engine and keep the engine speed between 3,500 and 4,000 rpm for at least 1 minute under no load.
7. Let engine idle for 1 minute.
8. Check that "COOLAN TEMP/S" indicates more than 70°C (158°F).
If not, warm up engine and go to next step when "COOLAN TEMP/S" indication reaches 70°C (158°F).
9. Open engine hood.
10. Select "HO2S2 (B1) P1146" (for DTC P0138) or "HO2S2 (B2) P1166" (for DTC P0158) of "HO2S2" in "DTC WORK SUPPORT" mode with CONSULT-III.
11. Follow the instruction of CONSULT-III display.

NOTE:

It will take at most 10 minutes until "COMPLETED" is displayed.

12. Touch "SELF-DIAG RESULTS".

Which is displayed on CONSULT-III screen?

- OK >> INSPECTION END
- NG >> Go to [EC-213, "Diagnosis Procedure"](#).
- CON NOT BE DIAGNOSED>>GO TO 4.

4. PERFORM DTC CONFIRMATION PROCEDURE FOR MALFUNCTION B AGAIN

1. Turn ignition switch OFF and leave the vehicle in a cool place (soak the vehicle).

< COMPONENT DIAGNOSIS >

2. Perform DTC confirmation procedure again.

>> GO TO 3.

5. PERFORM COMPONENT FUNCTION CHECK FOR MALFUNCTION B

Perform component function check. Refer to [EC-212, "Component Function Check"](#).

NOTE:

Use component function check to check the overall function of the heated oxygen sensor 2 circuit. During this check, a 1st trip DTC might not be confirmed.

Is the inspection result normal?

- YES >> INSPECTION END
- NO >> Go to [EC-213, "Diagnosis Procedure"](#).

Component Function Check

INFOID:000000003388007

1. PERFORM COMPONENT FUNCTION CHECK-I

⊗ Without CONSULT-III

1. Start engine and warm it up to the normal operating temperature.
2. Turn ignition switch OFF and wait at least 10 seconds.
3. Turn ignition switch ON.
4. Turn ignition switch OFF and wait at least 10 seconds.
5. Start engine and keep the engine speed between 3,500 and 4,000 rpm for at least 1 minute under no load.
6. Let engine idle for 1 minute.
7. Check the voltage between ECM harness connector terminals under the following conditions.

DTC	ECM			Condition	Voltage
	Connector	+	-		
		Terminal	Terminal		
P0138	F8	33 [HO2S2 (bank 1) signal]	35 (Sensor ground)	Revving up to 4,000 rpm under no load at least 10 times	The voltage should be below 0.18 V at least once during this procedure.
P0158		34 [HO2S2 (bank 2) signal]			

Is the inspection result normal?

- YES >> INSPECTION END
- NO >> GO TO 2.

2. PERFORM COMPONENT FUNCTION CHECK-II

Check the voltage between ECM harness connector terminals under the following conditions.

DTC	ECM			Condition	Voltage
	Connector	+	-		
		Terminal	Terminal		
P0138	F8	33 [HO2S2 (bank 1) signal]	35 (Sensor ground)	Keeping engine speed at idle for 10 minutes	The voltage should be below 0.18 V at least once during this procedure.
P0158		34 [HO2S2 (bank 2) signal]			

Is the inspection result normal?

- YES >> INSPECTION END
- NO >> GO TO 3.

3. PERFORM COMPONENT FUNCTION CHECK-III

P0138, P0158 HO2S2

< COMPONENT DIAGNOSIS >

[VQ35DE]

Check the voltage between ECM harness connector terminals under the following conditions.

DTC	ECM			Condition	Voltage
	Conne- tor	+	-		
		Terminal	Terminal		
P0138	F8	33 [HO2S2 (bank 1) signal]	35 (Sensor ground)	Coasting from 80 km/h (50 MPH) with selector lever in the D position	The voltage should be below 0.18 V at least once during this procedure.
P0158		34 [HO2S2 (bank 2) signal]			

Is the inspection result normal?

YES >> INSPECTION END

NO >> Go to [EC-213. "Diagnosis Procedure"](#).

Diagnosis Procedure

INFOID:000000003388008

1.INSPECTION START

Confirm the detected malfunction (A or B). Refer to [EC-210. "DTC Logic"](#).

Which malfunction is detected?

A >> GO TO 2.

B >> GO TO 9.

2.CHECK GROUND CONNECTION

1. Turn ignition switch OFF.

2. Check ground connection E38. Refer to Ground Inspection in [GI-43. "Circuit Inspection"](#).

Is the inspection result normal?

YES >> GO TO 3.

NO >> Repair or replace ground connection.

3.CHECK HO2S2 CONNECTOR FOR WATER

1. Disconnect heated oxygen sensor 2 harness connector.

2. Check that water is not inside connectors.

Is the inspection result normal?

YES >> GO TO 4.

NO >> Repair or replace harness or connectors.

4.CHECK HO2S2 GROUND CIRCUIT FOR OPEN AND SHORT

1. Disconnect heated oxygen sensor 2 harness connector.

2. Disconnect ECM harness connector.

3. Check the continuity between heated oxygen sensor 2 (HO2S2) harness connector and ECM harness connector.

DTC	HO2S2			ECM		Continuity
	Bank	Connector	Terminal	Connector	Terminal	
P0138	1	F70	1	F8	35	Existed
P0158	2	F71	1			

4. Also check harness for short to ground and short to power.

Is the inspection result normal?

YES >> GO TO 5.

NO >> Repair open circuit, short to ground or short to power in harness or connectors.

5.CHECK HO2S2 INPUT SIGNAL CIRCUIT FOR OPEN AND SHORT

1. Check the continuity between HO2S2 harness connector and ECM harness connector.

< COMPONENT DIAGNOSIS >

DTC	HO2S2			ECM		Continuity
	Bank	Connector	Terminal	Connector	Terminal	
P0138	1	F70	4	F8	33	Existed
P0158	2	F71	4		34	

2. Check the continuity between HO2S2 harness connector and ground, or ECM harness connector and ground.

DTC	HO2S2			Ground	Continuity
	Bank	Connector	Terminal		
P0138	1	F70	4	Ground	Not existed
P0158	2	F71	4		

DTC	ECM		Ground	Continuity
	Connector	Terminal		
P0138	F8	33	Ground	Not existed
P0158		34		

3. Also check harness for short to power.

Is the inspection result normal?

YES >> GO TO 6.

NO >> Repair open circuit, short to ground or short to power in harness or connectors.

6.CHECK HEATED OXYGEN SENSOR 2

Refer to [EC-216, "Component Inspection"](#).

Is the inspection result normal?

YES >> GO TO 8.

NO >> GO TO 7.

7.REPLACE HEATED OXYGEN SENSOR 2

Replace malfunctioning heated oxygen sensor 2.

CAUTION:

- Discard any heated oxygen sensor which has been dropped from a height of more than 0.5 m (19.7 in) onto a hard surface such as a concrete floor; use a new one.
- Before installing new oxygen sensor, clean exhaust system threads using Oxygen Sensor Thread Cleaner [commercial service tool (J-43897-18 or J-43897-12)] and approved anti-seize lubricant (commercial service tool).

>> INSPECTION END

8.CHECK INTERMITTENT INCIDENT

Refer to [GI-40, "Intermittent Incident"](#).

>> INSPECTION END

9.CHECK GROUND CONNECTION

1. Turn ignition switch OFF.

2. Check ground connection E38. Refer to Ground Inspection in [GI-43, "Circuit Inspection"](#).

Is the inspection result normal?

YES >> GO TO 10.

NO >> Repair or replace ground connection.

10.CLEAR MIXTURE RATIO SELF-LEARNING VALUE

P0138, P0158 HO2S2

[VQ35DE]

< COMPONENT DIAGNOSIS >

1. Clear the mixture ratio self-learning value. Refer to [EC-19. "MIXTURE RATIO SELF-LEARNING VALUE CLEAR : Special Repair Requirement"](#).
2. Run engine for at least 10 minutes at idle speed.

Is the 1st trip DTC P0172 or P0175 detected? Is it difficult to start engine?

- YES >> Perform trouble diagnosis for DTC P0172, P0175. Refer to [EC-231. "DTC Logic"](#).
 NO >> GO TO 11.

11. CHECK HO2S2 GROUND CIRCUIT FOR OPEN AND SHORT

1. Turn ignition switch OFF.
2. Disconnect heated oxygen sensor 2 harness connector.
3. Disconnect ECM harness connector.
4. Check the continuity between HO2S2 harness connector and ECM harness connector.

DTC	HO2S2			ECM		Continuity
	Bank	Connector	Terminal	Connector	Terminal	
P0138	1	F70	1	F8	35	Existed
P0158	2	F71	1			

5. Also check harness for short to ground and short to power.

Is the inspection result normal?

- YES >> GO TO 12.
 NO >> Repair open circuit, short to ground or short to power in harness or connectors.

12. CHECK HO2S2 INPUT SIGNAL CIRCUIT FOR OPEN AND SHORT

1. Check the continuity between HO2S2 harness connector and ECM harness connector.

DTC	HO2S2			ECM		Continuity
	Bank	Connector	Terminal	Connector	Terminal	
P0138	1	F70	4	F8	33	Existed
P0158	2	F71	4		34	

2. Check the continuity between HO2S2 harness connector and ground, or ECM harness connector and ground.

DTC	HO2S2			Ground	Continuity
	Bank	Connector	Terminal		
P0138	1	F70	4	Ground	Not existed
P0158	2	F71	4		

DTC	ECM		Ground	Continuity
	Connector	Terminal		
P0138	F8	33	Ground	Not existed
P0158		34		

3. Also check harness for short to power.

Is the inspection result normal?

- YES >> GO TO 13.
 NO >> Repair open circuit, short to ground or short to power in harness or connectors.

13. CHECK HEATED OXYGEN SENSOR 2

Refer to [EC-216. "Component Inspection"](#).

Is the inspection result normal?

- YES >> GO TO 15.
 NO >> GO TO 14.

< COMPONENT DIAGNOSIS >

14.REPLACE HEATED OXYGEN SENSOR 2

Replace malfunctioning heated oxygen sensor 2.

CAUTION:

- Discard any heated oxygen sensor which has been dropped from a height of more than 0.5 m (19.7 in) onto a hard surface such as a concrete floor; use a new one.
- Before installing new oxygen sensor, clean exhaust system threads using Oxygen Sensor Thread Cleaner [commercial service tool (J-43897-18 or J-43897-12)] and approved anti-seize lubricant (commercial service tool).

>> INSPECTION END

15.CHECK INTERMITTENT INCIDENT

Refer to [GI-40. "Intermittent Incident"](#).

>> INSPECTION END

Component Inspection

INFOID:000000003624898

1.INSPECTION START

Will CONSULT-III be used?

Will CONSULT-III be used?

- YES >> GO TO 2.
NO >> GO TO 3.

2.CHECK HEATED OXYGEN SENSOR 2**Ⓢ**With CONSULT-III

1. Turn ignition switch ON and select "DATA MONITOR" mode with CONSULT-III.
2. Start engine and warm it up to the normal operating temperature.
3. Turn ignition switch OFF and wait at least 10 seconds.
4. Start engine and keep the engine speed between 3,500 and 4,000 rpm for at least 1 minute under no load.
5. Let engine idle for 1 minute.
6. Select "FUEL INJECTION" in "ACTIVE TEST" mode, and select "HO2S2 (B1)/(B2)" as the monitor item with CONSULT-III.
7. Check "HO2S2 (B1)/(B2)" at idle speed when adjusting "FUEL INJECTION" to $\pm 25\%$.

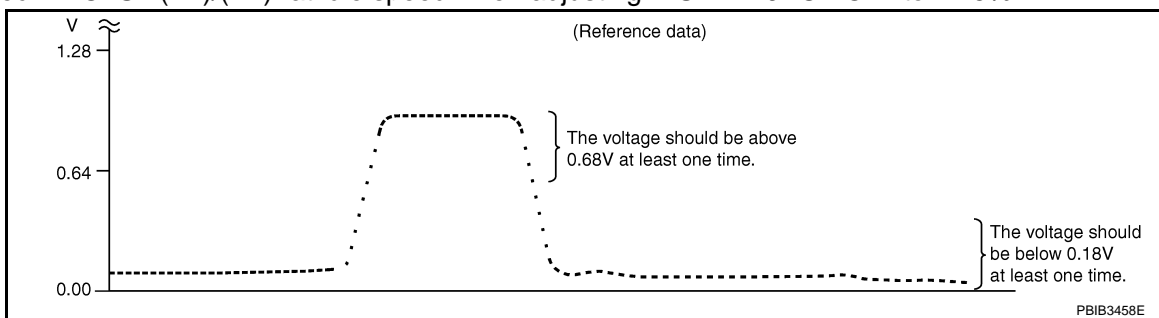

"HO2S2 (B1)/(B2)" should be above 0.68 V at least once when the "FUEL INJECTION" is + 25%.

"HO2S2 (B1)/(B2)" should be below 0.18 V at least once when the "FUEL INJECTION" is - 25%.

Is the inspection result normal?

- YES >> INSPECTION END
NO >> GO TO 6.

3.CHECK HEATED OXYGEN SENSOR 2-I**ⓧ**Without CONSULT-III

1. Start engine and warm it up to the normal operating temperature.
2. Turn ignition switch OFF and wait at least 10 seconds.
3. Start engine and keep the engine speed between 3,500 and 4,000 rpm for at least 1 minute under no load.
4. Let engine idle for 1 minute.
5. Check the voltage between ECM harness connector terminals under the following conditions.

ECM			Condition	Voltage
Connector	+	-		
		Terminal	Terminal	
F8	33 [HO2S2 (bank 1) signal]	35 (Sensor ground)	Revvng up to 4,000 rpm under no load at least 10 times	The voltage should be above 0.68 V at least once during this procedure. The voltage should be below 0.18 V at least once during this procedure.
	34 [HO2S2 (bank 2) signal]			

Is the inspection result normal?

YES >> INSPECTION END
NO >> GO TO 4.

4.CHECK HEATED OXYGEN SENSOR 2-II

Check the voltage between ECM harness connector terminals under the following conditions.

ECM			Condition	Voltage
Connector	+	-		
		Terminal	Terminal	
F8	33 [HO2S2 (bank 1) signal]	35 (Sensor ground)	Keeping engine at idle for 10 minutes	The voltage should be above 0.68 V at least once during this procedure. The voltage should be below 0.18 V at least once during this procedure.
	34 [HO2S2 (bank 2) signal]			

Is the inspection result normal?

YES >> INSPECTION END
NO >> GO TO 5.

5.CHECK HEATED OXYGEN SENSOR 2-III

Check the voltage between ECM harness connector terminals under the following conditions.

ECM			Condition	Voltage
Connector	+	-		
		Terminal	Terminal	
F8	33 [HO2S2 (bank 1) signal]	35 (Sensor ground)	Coasting from 80 km/h (50 MPH) with selector lever in the D position	The voltage should be above 0.68 V at least once during this procedure. The voltage should be below 0.18 V at least once during this procedure.
	34 [HO2S2 (bank 2) signal]			

Is the inspection result normal?

YES >> INSPECTION END
NO >> GO TO 6.

6.REPLACE HEATED OXYGEN SENSOR 2

Replace malfunctioning heated oxygen sensor 2.

CAUTION:

- Discard any heated oxygen sensor which has been dropped from a height of more than 0.5 m (19.7 in) onto a hard surface such as a concrete floor; use a new one.
- Before installing new oxygen sensor, clean exhaust system threads using Oxygen Sensor Thread Cleaner [commercial service tool (J-43897-18 or J-43897-12)] and approved anti-seize lubricant (commercial service tool).

>> INSPECTION END

P0139, P0159 HO2S2

Description

INFOID:000000003591596

The heated oxygen sensor 2, after three way catalyst (manifold), monitors the oxygen level in the exhaust gas on each bank. Even if switching characteristics of the air fuel ratio (A/F) sensor 1 are shifted, the air-fuel ratio is controlled to stoichiometric, by the signal from the heated oxygen sensor 2. This sensor is made of ceramic zirconia. The zirconia generates voltage from approximately 1 V in richer conditions to 0 V in leaner conditions. Under normal conditions the heated oxygen sensor 2 is not used for engine control operation.

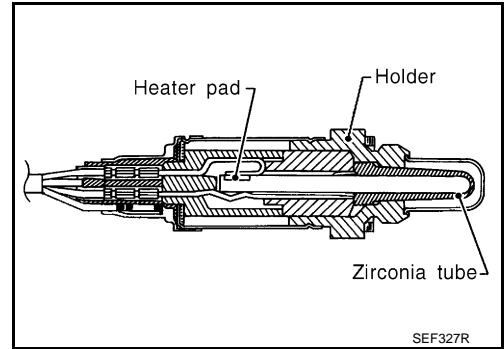

DTC Logic

INFOID:000000003388011

DTC DETECTION LOGIC

The heated oxygen sensor 2 has a much longer switching time between rich and lean than the air fuel ratio (A/F) sensor 1. The oxygen storage capacity of the three way catalyst (manifold) causes the longer switching time. To judge the malfunctions of heated oxygen sensor 2, ECM monitors whether the switching response of the sensor's voltage is faster than specified during various driving conditions such as fuel-cut.

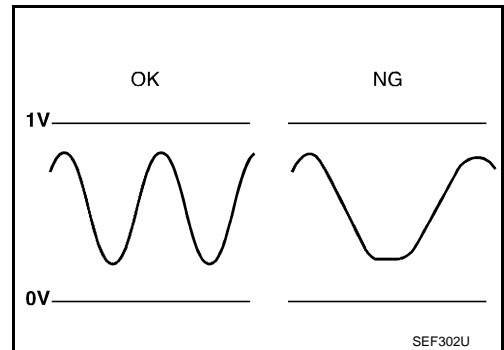

DTC No.	Trouble diagnosis name	DTC detecting condition	Possible cause
P0139	Heated oxygen sensor 2 (bank 1) circuit slow response	It takes more time for the sensor to respond between rich and lean than the specified time.	<ul style="list-style-type: none"> • Harness or connectors (The sensor circuit is open or shorted) • Heated oxygen sensor 2 • Fuel pressure • Fuel injector • Intake air leakage
P0159	Heated oxygen sensor 2 (bank 2) circuit slow response		

DTC CONFIRMATION PROCEDURE

1.INSPECTION START

Will CONSULT-III be used?

Will CONSULT-III be used?

YES >> GO TO 2.

NO >> GO TO 5.

2.PRECONDITIONING

If DTC Confirmation Procedure has been previously conducted, always perform the following before conducting the next test.

1. Turn ignition switch OFF and wait at least 10 seconds.
2. Turn ignition switch ON.
3. Turn ignition switch OFF and wait at least 10 seconds.

TESTING CONDITION:

For better results, perform "DTC WORK SUPPORT" at a temperature of 0 to 30°C (32 to 86°F).

>> GO TO 3.

3. PERFORM DTC CONFIRMATION PROCEDURE**④ With CONSULT-III**

1. Turn ignition switch ON and select "DATA MONITOR" mode with CONSULT-III.
2. Start engine and warm it up to the normal operating temperature.
3. Turn ignition switch OFF and wait at least 10 seconds.
4. Turn ignition switch ON.
5. Turn ignition switch OFF and wait at least 10 seconds.
6. Start engine and keep the engine speed between 3,500 and 4,000 rpm for at least 1 minute under no load.
7. Let engine idle for 1 minute.
8. Open engine hood.
9. Select "HO2S2 (B1) P0139" or "HO2S2 (B2) P0159" of "HO2S2" in "DTC WORK SUPPORT" mode with CONSULT-III.
10. Follow the instruction of CONSULT-III display.

NOTE:

It will take at most 10 minutes until "COMPLETED" is displayed.

11. Touch "SELF-DIAG RESULTS".

Which is displayed on CONSULT-III screen?

- OK >> INSPECTION END
 NG >> Go to [EC-221, "Diagnosis Procedure"](#).
 CAN NOT BE DIAGNOSED>>GO TO 4.

4. PERFORM DTC CONFIRMATION PROCEDURE AGAIN

1. Turn ignition switch OFF and leave the vehicle in a cool place (soak the vehicle).
2. Perform DTC confirmation procedure again.

>> GO TO 3.

5. PERFORM COMPONENT FUNCTION CHECK

Perform component function check. Refer to [EC-220, "Component Function Check"](#).

NOTE:

Use component function check to check the overall function of the heated oxygen sensor 2 circuit. During this check, a 1st trip DTC might not be confirmed.

Is the inspection result normal?

- YES >> INSPECTION END
 NO >> Go to [EC-221, "Diagnosis Procedure"](#).

Component Function Check

INFOID:000000003388012

1. PERFORM COMPONENT FUNCTION CHECK-I**⊗ Without CONSULT-III**

1. Start engine and warm it up to the normal operating temperature.
2. Turn ignition switch OFF and wait at least 10 seconds.
3. Turn ignition switch ON.
4. Turn ignition switch OFF and wait at least 10 seconds.
5. Start engine and keep the engine speed between 3,500 and 4,000 rpm for at least 1 minute under no load.
6. Let engine idle for 1 minute.
7. Check the voltage between ECM harness connector terminals under the following conditions.

P0139, P0159 HO2S2

< COMPONENT DIAGNOSIS >

[VQ35DE]

DTC	ECM			Condition	Voltage
	Connector	+	-		
		Terminal	Terminal		
P0139	F8	33 [HO2S2 (bank 1) signal]	35 (Sensor ground)	Revving up to 4,000 rpm under no load at least 10 times	A change of voltage should be more than 0.24 V for 1 second during this procedure.
P0159		34 [HO2S2 (bank 2) signal]			

Is the inspection result normal?

YES >> INSPECTION END
NO >> GO TO 2.

2.PERFORM COMPONENT FUNCTION CHECK-II

Check the voltage between ECM harness connector terminals under the following conditions.

DTC	ECM			Condition	Voltage
	Connector	+	-		
		Terminal	Terminal		
P0139	F8	33 [HO2S2 (bank 1) signal]	35 (Sensor ground)	Keeping engine at idle for 10 minutes	A change of voltage should be more than 0.24 V for 1 second during this procedure.
P0159		34 [HO2S2 (bank 2) signal]			

Is the inspection result normal?

YES >> INSPECTION END
NO >> GO TO 3.

3.PERFORM COMPONENT FUNCTION CHECK-III

Check the voltage between ECM harness connector terminals under the following conditions.

DTC	ECM			Condition	Voltage
	Connector	+	-		
		Terminal	Terminal		
P0139	F8	33 [HO2S2 (bank 1) signal]	35 (Sensor ground)	Coasting from 80 km/h (50 MPH) in D position	A change of voltage should be more than 0.24 V for 1 second during this procedure.
P0159		34 [HO2S2 (bank 2) signal]			

Is the inspection result normal?

YES >> INSPECTION END
NO >> Go to [EC-221, "Diagnosis Procedure"](#).

Diagnosis Procedure

INFOID:000000003388013

1.CHECK GROUND CONNECTION

1. Turn ignition switch OFF.
2. Check ground connection E38. Refer to Ground Inspection in [GI-43, "Circuit Inspection"](#).

Is the inspection result normal?

YES >> GO TO 2.

P0139, P0159 HO2S2

[VQ35DE]

< COMPONENT DIAGNOSIS >

NO >> Repair or replace ground connection.

2. CLEAR MIXTURE RATIO SELF-LEARNING VALUE

1. Clear the mixture ratio self-learning value. Refer to [EC-19, "MIXTURE RATIO SELF-LEARNING VALUE CLEAR : Special Repair Requirement"](#).
2. Run engine for at least 10 minutes at idle speed.

Is the 1st trip DTC P0171, P0172, P0174 or P0175 detected? Is it difficult to start engine?

YES >> Perform trouble diagnosis for DTC P0171, P0174 or P0172, P0175. Refer to [EC-226, "DTC Logic"](#) or [EC-231, "DTC Logic"](#).

NO >> GO TO 3.

3. CHECK HO2S2 GROUND CIRCUIT FOR OPEN AND SHORT

1. Turn ignition switch OFF.
2. Disconnect heated oxygen sensor 2 harness connector.
3. Disconnect ECM harness connector.
4. Check the continuity between heated oxygen sensor 2 (HO2S2) harness connector and ECM harness connector.

DTC	HO2S2			ECM		Continuity
	Bank	Connector	Terminal	Connector	Terminal	
P0139	1	F70	1	F8	35	Existed
P0159	2	F71	1			

5. Also check harness for short to ground and short to power.

Is the inspection result normal?

YES >> GO TO 4.

NO >> Repair open circuit, short to ground or short to power in harness or connectors.

4. CHECK HO2S2 INPUT SIGNAL CIRCUIT FOR OPEN AND SHORT

1. Check the continuity between HO2S2 harness connector and ECM harness connector.

DTC	HO2S2			ECM		Continuity
	Bank	Connector	Terminal	Connector	Terminal	
P0139	1	F70	4	F8	33	Existed
P0159	2	F71	4		34	

2. Check the continuity between HO2S2 harness connector and ground, or ECM harness connector and ground.

DTC	HO2S2			Ground	Continuity
	Bank	Connector	Terminal		
P0139	1	F70	4	Ground	Not existed
P0159	2	F71	4		

DTC	ECM		Ground	Continuity
	Connector	Terminal		
P0139	F8	33	Ground	Not existed
P0159		34		

3. Also check harness for short to power.

Is the inspection result normal?

YES >> GO TO 5.

NO >> Repair open circuit, short to ground or short to power in harness or connectors.

5. CHECK HEATED OXYGEN SENSOR 2

< COMPONENT DIAGNOSIS >

Refer to [EC-223, "Component Inspection"](#).

Is the inspection result normal?

- YES >> GO TO 7.
- NO >> GO TO 6.

6. REPLACE HEATED OXYGEN SENSOR 2

Replace malfunctioning heated oxygen sensor 2.

CAUTION:

- Discard any heated oxygen sensor which has been dropped from a height of more than 0.5 m (19.7 in) onto a hard surface such as a concrete floor; use a new one.
- Before installing new oxygen sensor, clean exhaust system threads using Oxygen Sensor Thread Cleaner [commercial service tool (J-43897-18 or J-43897-12)] and approved anti-seize lubricant (commercial service tool).

>> INSPECTION END

7. CHECK INTERMITTENT INCIDENT

Refer to [GI-40, "Intermittent Incident"](#).

>> INSPECTION END

Component Inspection

INFOID:000000003625196

1. INSPECTION START

Will CONSULT-III be used?

Will CONSULT-III be used?

- YES >> GO TO 2.
- NO >> GO TO 3.

2. CHECK HEATED OXYGEN SENSOR 2

Ⓜ With CONSULT-III

1. Turn ignition switch ON and select "DATA MONITOR" mode with CONSULT-III.
2. Start engine and warm it up to the normal operating temperature.
3. Turn ignition switch OFF and wait at least 10 seconds.
4. Start engine and keep the engine speed between 3,500 and 4,000 rpm for at least 1 minute under no load.
5. Let engine idle for 1 minute.
6. Select "FUEL INJECTION" in "ACTIVE TEST" mode, and select "HO2S2 (B1)/(B2)" as the monitor item with CONSULT-III.
7. Check "HO2S2 (B1)/(B2)" at idle speed when adjusting "FUEL INJECTION" to $\pm 25\%$.

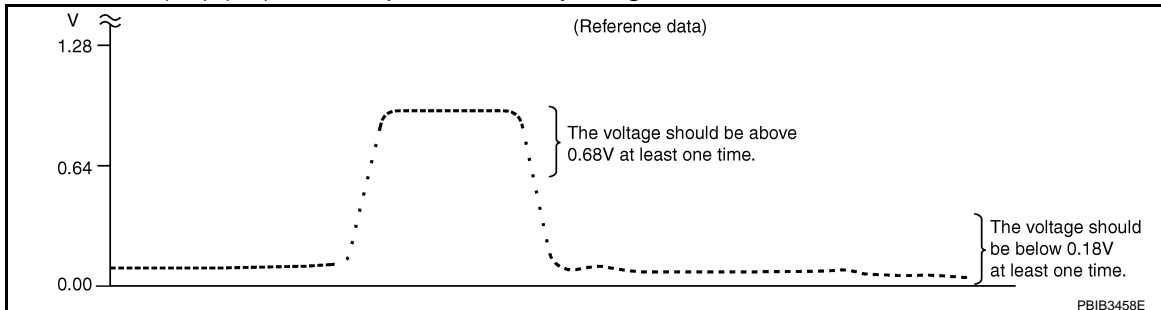

"HO2S2 (B1)/(B2)" should be above 0.68 V at least once when the "FUEL INJECTION" is + 25%.

"HO2S2 (B1)/(B2)" should be below 0.18 V at least once when the "FUEL INJECTION" is - 25%.

Is the inspection result normal?

- YES >> INSPECTION END
- NO >> GO TO 6.

3. CHECK HEATED OXYGEN SENSOR 2-I

Ⓧ Without CONSULT-III

1. Start engine and warm it up to the normal operating temperature.

< COMPONENT DIAGNOSIS >

2. Turn ignition switch OFF and wait at least 10 seconds.
3. Start engine and keep the engine speed between 3,500 and 4,000 rpm for at least 1 minute under no load.
4. Let engine idle for 1 minute.
5. Check the voltage between ECM harness connector terminals under the following conditions.

ECM			Condition	Voltage
Connector	+	-		
	Terminal	Terminal		
F8	33 [HO2S2 (bank 1) signal]	35 (Sensor ground)	Revving up to 4,000 rpm under no load at least 10 times	The voltage should be above 0.68 V at least once during this procedure. The voltage should be below 0.18 V at least once during this procedure.
	34 [HO2S2 (bank 2) signal]			

Is the inspection result normal?

- YES >> INSPECTION END
NO >> GO TO 4.

4.CHECK HEATED OXYGEN SENSOR 2-II

Check the voltage between ECM harness connector terminals under the following conditions.

ECM			Condition	Voltage
Connector	+	-		
	Terminal	Terminal		
F8	33 [HO2S2 (bank 1) signal]	35 (Sensor ground)	Keeping engine at idle for 10 minutes	The voltage should be above 0.68 V at least once during this procedure. The voltage should be below 0.18 V at least once during this procedure.
	34 [HO2S2 (bank 2) signal]			

Is the inspection result normal?

- YES >> INSPECTION END
NO >> GO TO 5.

5.CHECK HEATED OXYGEN SENSOR 2-III

Check the voltage between ECM harness connector terminals under the following conditions.

ECM			Condition	Voltage
Connector	+	-		
	Terminal	Terminal		
F8	33 [HO2S2 (bank 1) signal]	35 (Sensor ground)	Coasting from 80 km/h (50 MPH) with selector lever in the D position	The voltage should be above 0.68 V at least once during this procedure. The voltage should be below 0.18 V at least once during this procedure.
	34 [HO2S2 (bank 2) signal]			

Is the inspection result normal?

- YES >> INSPECTION END
NO >> GO TO 6.

6.REPLACE HEATED OXYGEN SENSOR 2

Replace malfunctioning heated oxygen sensor 2.

CAUTION:

- Discard any heated oxygen sensor which has been dropped from a height of more than 0.5 m (19.7 in) onto a hard surface such as a concrete floor; use a new one.

P0139, P0159 HO2S2

< COMPONENT DIAGNOSIS >

[VQ35DE]

- Before installing new oxygen sensor, clean exhaust system threads using Oxygen Sensor Thread Cleaner [commercial service tool (J-43897-18 or J-43897-12)] and approved anti-seize lubricant (commercial service tool).

A

>> INSPECTION END

EC

C

D

E

F

G

H

I

J

K

L

M

N

O

P

P0171, P0174 FUEL INJECTION SYSTEM FUNCTION

< COMPONENT DIAGNOSIS >

[VQ35DE]

P0171, P0174 FUEL INJECTION SYSTEM FUNCTION

DTC Logic

INFOID:000000003388015

DTC DETECTION LOGIC

With the Air/Fuel Mixture Ratio Self-Learning Control, the actual mixture ratio can be brought closely to the theoretical mixture ratio based on the mixture ratio feedback signal from A/F sensor 1. The ECM calculates the necessary compensation to correct the offset between the actual and the theoretical ratios.

In case the amount of the compensation value is extremely large (the actual mixture ratio is too lean), the ECM judges the condition as the fuel injection system malfunction and illuminates the MIL (2 trip detection logic).

Sensor	Input signal to ECM	ECM function	Actuator
A/F sensor 1	Density of oxygen in exhaust gas (Mixture ratio feedback signal)	Fuel injection control	Fuel injector

DTC No.	Trouble diagnosis name	DTC detecting condition	Possible cause
P0171	Fuel injection system too lean (bank 1)	<ul style="list-style-type: none"> Fuel injection system does not operate properly. The amount of mixture ratio compensation is too large. (The mixture ratio is too lean.) 	<ul style="list-style-type: none"> Intake air leakage A/F sensor 1 Fuel injector Exhaust gas leakage Incorrect fuel pressure Lack of fuel Mass air flow sensor Incorrect PCV hose connection
P0174	Fuel injection system too lean (bank 2)		

DTC CONFIRMATION PROCEDURE

NOTE:

Check vehicle specifications and VIN, then select the procedure to be performed. (Refer to the table below.)

Vehicle specification	Vehicle serial number	TYPE
2WD	Up to JN8AZ18U*9W100000	A
	From JN8AZ18U*9W100001	B
	Up to JN8AZ18U*9W710000	A
	From JN8AZ18U*9W710001	B
4WD	Up to JN8AZ18W*9W200000	A
	From JN8AZ18W*9W200001	B
	Up to JN8AZ18W*9W810000	A
	From JN8AZ18W*9W810001	B

TYPE A

1. PRECONDITIONING

If DTC Confirmation Procedure has been previously conducted, always perform the following before conducting the next test.

- Turn ignition switch OFF and wait at least 10 seconds.
- Turn ignition switch ON.
- Turn ignition switch OFF and wait at least 10 seconds.

>> GO TO 2.

2. PERFORM DTC CONFIRMATION PROCEDURE-I

- Clear the mixture ratio self-learning value. Refer to [EC-19, "MIXTURE RATIO SELF-LEARNING VALUE CLEAR : Special Repair Requirement"](#).
- Start engine.

Is it difficult to start engine?

P0171, P0174 FUEL INJECTION SYSTEM FUNCTION

< COMPONENT DIAGNOSIS >

[VQ35DE]

- YES >> GO TO 3.
- NO >> GO TO 4.

3.RESTART ENGINE

If it is difficult to start engine, the fuel injection system has a malfunction, too.
Crank engine while depressing accelerator pedal.

NOTE:

- **When depressing accelerator pedal three-fourths (3/4) or more, the control system does not start the engine. Do not depress accelerator pedal too much.**

Does engine start?

- YES >> Go to [EC-228, "Diagnosis Procedure"](#).
- NO >> Check exhaust and intake air leakage visually.

4.PERFORM DTC CONFIRMATION PROCEDURE-II

1. Keep engine idle for at least 10 minutes.
2. Check 1st trip DTC.

Is 1st trip DTC detected?

- YES >> Go to [EC-228, "Diagnosis Procedure"](#).
- NO >> GO TO 5.

5.PERFORM DTC CONFIRMATION PROCEDURE-III

1. Turn ignition switch OFF and wait at least 10 seconds.
2. Start engine and drive the vehicle under similar conditions to (1st trip) Freeze Frame Data for 10 minutes. Refer to the table below.

Hold the accelerator pedal as steady as possible.

Similar conditions to (1st trip) Freeze Frame Data mean that the following conditions should be satisfied at the same time.

Engine speed	Engine speed in the freeze frame data \pm 400 rpm
Vehicle speed	Vehicle speed in the freeze frame data \pm 10 km/h (6 MPH)
Basic fuel schedule	Basic fuel schedule in freeze frame data \times (1 \pm 0.1)
Engine coolant temperature (T) condition	When the freeze frame data shows lower than 70°C (158°F), T should be lower than 70°C (158°F).
	When the freeze frame data shows higher than or equal to 70°C (158°F), T should be higher than or equal to 70°C (158°F).

3. Check 1st trip DTC.

Is 1st trip DTC detected?

- YES >> Go to [EC-228, "Diagnosis Procedure"](#).
- NO >> INSPECTION END

TYPE B

1.PRECONDITIONING

If DTC Confirmation Procedure has been previously conducted, always perform the following before conducting the next test.

1. Turn ignition switch OFF and wait at least 10 seconds.
2. Turn ignition switch ON.
3. Turn ignition switch OFF and wait at least 10 seconds.

>> GO TO 2.

2.PERFORM DTC CONFIRMATION PROCEDURE-I

1. Clear the mixture ratio self-learning value. Refer to [EC-19, "MIXTURE RATIO SELF-LEARNING VALUE CLEAR : Special Repair Requirement"](#).
2. Start engine.

Is it difficult to start engine?

- YES >> GO TO 3.

P0171, P0174 FUEL INJECTION SYSTEM FUNCTION

[VQ35DE]

< COMPONENT DIAGNOSIS >

NO >> GO TO 4.

3.RESTART ENGINE

If it is difficult to start engine, the fuel injection system has a malfunction, too.
Crank engine while depressing accelerator pedal.

NOTE:

- When depressing accelerator pedal three-fourths (3/4) or more, the control system does not start the engine. Do not depress accelerator pedal too much.

Does engine start?

- YES >> Go to [EC-228, "Diagnosis Procedure"](#).
NO >> Check exhaust and intake air leakage visually.

4.PERFORM DTC CONFIRMATION PROCEDURE-II

1. Keep engine idle for at least 5 minutes.
2. Check 1st trip DTC.

Is 1st trip DTC detected?

- YES >> Go to [EC-228, "Diagnosis Procedure"](#).
NO >> GO TO 5.

5.PERFORM DTC CONFIRMATION PROCEDURE-III

1. Turn ignition switch OFF and wait at least 10 seconds.
2. Start engine.
3. Maintain the following conditions for at least 10 consecutive minutes.
Hold the accelerator pedal as steady as possible.

VHCL SPEED SE	50 - 120 km/h (31 - 75 mph)
---------------	-----------------------------

CAUTION:

Always drive vehicle at a safe speed.

4. Check 1st trip DTC.

Is 1st trip DTC detected?

- YES >> Go to [EC-228, "Diagnosis Procedure"](#).
NO >> INSPECTION END

Diagnosis Procedure

INFOID:000000003388016

1.CHECK EXHAUST GAS LEAKAGE

1. Start engine and run it at idle.
2. Listen for an exhaust gas leakage before three way catalyst (manifold).

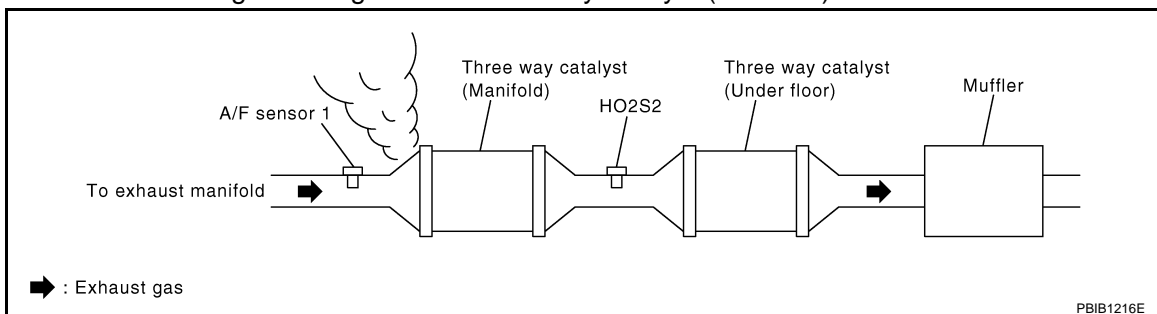

Is exhaust gas leakage detected?

- YES >> Repair or replace malfunctioning part.
NO >> GO TO 2.

2.CHECK FOR INTAKE AIR LEAKAGE

1. Listen for an intake air leakage after the mass air flow sensor.
2. Check PCV hose connection.

Is intake air leakage detected?

- YES >> Repair or replace malfunctioning part.
NO >> GO TO 3.

P0171, P0174 FUEL INJECTION SYSTEM FUNCTION

< COMPONENT DIAGNOSIS >

[VQ35DE]

3. CHECK A/F SENSOR 1 INPUT SIGNAL CIRCUIT

1. Turn ignition switch OFF.
2. Disconnect corresponding A/F sensor 1 harness connector.
3. Disconnect ECM harness connector.
4. Check the continuity between A/F sensor 1 harness connector and ECM harness connector.

DTC	A/F sensor 1			ECM		Continuity
	Bank	Connector	Terminal	Connector	Terminal	
P0171	1	F27	1	F8	45	Existed
			2		49	
P0174	2	F64	1		53	
			2		57	

5. Check the continuity between A/F sensor 1 harness connector and ground, or ECM harness connector and ground.

DTC	A/F sensor 1			Ground	Continuity
	Bank	Connector	Terminal		
P0171	1	F27	1	Ground	Not existed
			2		
P0174	2	F64	1		
			2		

DTC	ECM		Ground	Continuity
	Connector	Terminal		
P0171	F8	45	Ground	Not existed
		49		
P0174		53		
		57		

6. Also check harness for short to power.

Is the inspection result normal?

YES >> GO TO 4.

NO >> Repair open circuit, short to ground or short to power in harness or connectors.

4. CHECK FUEL PRESSURE

1. Release fuel pressure to zero. Refer to [EC-545. "Inspection"](#).
2. Install fuel pressure gauge kit [SST (J-44321)] and check fuel pressure. Refer to [EC-545. "Inspection"](#).

At idling: Approximately 350 kPa (3.57 kg/cm², 51 psi)

Is the inspection result normal?

YES >> GO TO 6.

NO >> GO TO 5.

5. DETECT MALFUNCTIONING PART

Check fuel hoses and fuel tubes for clogging.

Is the inspection result normal?

YES >> Replace "fuel filter and fuel pump assembly".

NO >> Repair or replace malfunctioning part.

6. CHECK MASS AIR FLOW SENSOR

 With CONSULT-III

P0171, P0174 FUEL INJECTION SYSTEM FUNCTION

[VQ35DE]

< COMPONENT DIAGNOSIS >

1. Install all removed parts.
2. Check "MASS AIR FLOW" in "DATA MONITOR" mode with CONSULT-III.
For specification, refer to [EC-551, "Mass Air Flow Sensor"](#).

With GST

1. Install all removed parts.
2. Check mass air flow sensor signal in Service \$01 with GST.
For specification, refer to [EC-551, "Mass Air Flow Sensor"](#).

Is the measurement value within the specification?

YES >> GO TO 7.

NO >> Check connectors for rusted terminals or loose connections in the mass air flow sensor circuit or ground. Refer to [EC-163, "Diagnosis Procedure"](#).

7. CHECK FUNCTION OF FUEL INJECTOR

With CONSULT-III

1. Start engine.
2. Perform "POWER BALANCE" in "ACTIVE TEST" mode with CONSULT-III.
3. Check that each circuit produces a momentary engine speed drop.

With GST

1. Let engine idle.
2. Listen to each fuel injector operating sound.

Is the inspection result normal?

YES >> GO TO 8.

NO >> Perform trouble diagnosis for FUEL INJECTOR, refer to [EC-444, "Diagnosis Procedure"](#).

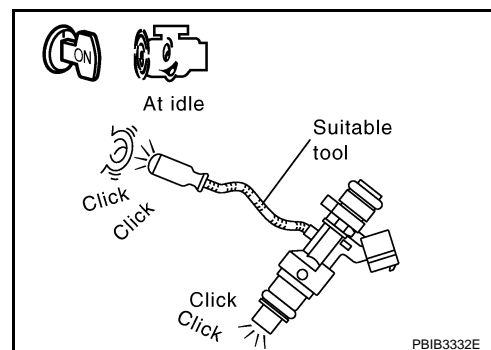

8. CHECK FUEL INJECTOR

1. Turn ignition switch OFF.
2. Confirm that the engine is cooled down and there are no fire hazards near the vehicle.
3. Disconnect all fuel injector harness connectors.
4. Remove fuel tube assembly. Refer to [EM-45, "Removal and Installation"](#).
Keep fuel hose and all fuel injectors connected to fuel tube.
5. For DTC P0171, reconnect fuel injector harness connectors on bank 1.
For DTC P0174, reconnect fuel injector harness connectors on bank 2.
6. Disconnect all ignition coil harness connectors.
7. Prepare pans or saucers under each fuel injector.
8. Crank engine for about 3 seconds.
For DTC P0171, check that fuel sprays out from fuel injectors on bank 1.
For DTC P0174, check that fuel sprays out from fuel injectors on bank 2.

Fuel should be sprayed evenly for each fuel injector.

Is the inspection result normal?

YES >> GO TO 9.

NO >> Replace fuel injectors from which fuel does not spray out. Always replace O-ring with new ones.

9. CHECK INTERMITTENT INCIDENT

Refer to [GI-40, "Intermittent Incident"](#).

>> INSPECTION END

P0172, P0175 FUEL INJECTION SYSTEM FUNCTION

< COMPONENT DIAGNOSIS >

[VQ35DE]

P0172, P0175 FUEL INJECTION SYSTEM FUNCTION

DTC Logic

INFOID:000000003388017

DTC DETECTION LOGIC

With the Air/Fuel Mixture Ratio Self-Learning Control, the actual mixture ratio can be brought closely to the theoretical mixture ratio based on the mixture ratio feedback signal from A/F sensor 1. The ECM calculates the necessary compensation to correct the offset between the actual and the theoretical ratios.

In case the amount of the compensation value is extremely large (the actual mixture ratio is too rich), the ECM judges the condition as the fuel injection system malfunction and illuminates the MIL (2 trip detection logic).

Sensor	Input signal to ECM	ECM function	Actuator
A/F sensor 1	Density of oxygen in exhaust gas (Mixture ratio feedback signal)	Fuel injection control	Fuel injector

DTC No.	Trouble diagnosis name	DTC detecting condition	Possible cause
P0172	Fuel injection system too rich (bank 1)	• Fuel injection system does not operate properly. • The amount of mixture ratio compensation is too large. (The mixture ratio is too rich.)	• A/F sensor 1 • Fuel injector • Exhaust gas leakage • Incorrect fuel pressure • Mass air flow sensor
P0175	Fuel injection system too rich (bank 2)		

DTC CONFIRMATION PROCEDURE

NOTE:

Check vehicle specifications and VIN, then select the procedure to be performed. (Refer to the table below.)

Vehicle specification	Vehicle serial number	TYPE
2WD	Up to JN8AZ18U*9W100000	A
	From JN8AZ18U*9W100001	B
	Up to JN8AZ18U*9W710000	A
	From JN8AZ18U*9W710001	B
4WD	Up to JN8AZ18W*9W200000	A
	From JN8AZ18W*9W200001	B
	Up to JN8AZ18W*9W810000	A
	From JN8AZ18W*9W810001	B

TYPE A

1. PRECONDITIONING

If DTC Confirmation Procedure has been previously conducted, always perform the following before conducting the next test.

1. Turn ignition switch OFF and wait at least 10 seconds.
2. Turn ignition switch ON.
3. Turn ignition switch OFF and wait at least 10 seconds.

>> GO TO 2.

2. PERFORM DTC CONFIRMATION PROCEDURE-I

1. Clear the mixture ratio self-learning value. Refer to [EC-19. "MIXTURE RATIO SELF-LEARNING VALUE CLEAR : Special Repair Requirement"](#).
2. Start engine.

Is it difficult to start engine?

YES >> GO TO 3.

NO >> GO TO 4.

3. RESTART ENGINE

P0172, P0175 FUEL INJECTION SYSTEM FUNCTION

[VQ35DE]

< COMPONENT DIAGNOSIS >

If it is difficult to start engine, the fuel injection system has a malfunction, too.
Crank engine while depressing accelerator pedal.

NOTE:

- When depressing accelerator pedal three-fourths (3/4) or more, the control system does not start the engine. Do not depress accelerator pedal too much.

Does engine start?

- YES >> Go to [EC-233, "Diagnosis Procedure"](#).
NO >> Check exhaust and intake air leakage visually.

4.PERFORM DTC CONFIRMATION PROCEDURE-II

1. Keep engine idle for at least 10 minutes.
2. Check 1st trip DTC.

Is 1st trip DTC detected?

- YES >> Go to [EC-233, "Diagnosis Procedure"](#).
NO >> GO TO 5.

5.PERFORM DTC CONFIRMATION PROCEDURE-III

1. Turn ignition switch OFF and wait at least 10 seconds.
2. Start engine and drive the vehicle under similar conditions to (1st trip) Freeze Frame Data for 10 minutes. Refer to the table below.

Hold the accelerator pedal as steady as possible.

Similar conditions to (1st trip) Freeze Frame Data mean that the following conditions should be satisfied at the same time.

Engine speed	Engine speed in the freeze frame data \pm 400 rpm
Vehicle speed	Vehicle speed in the freeze frame data \pm 10 km/h (6 MPH)
Basic fuel schedule	Basic fuel schedule in freeze frame data \times (1 \pm 0.1)
Engine coolant temperature (T) condition	When the freeze frame data shows lower than 70°C (158°F), T should be lower than 70°C (158°F).
	When the freeze frame data shows higher than or equal to 70°C (158°F), T should be higher than or equal to 70°C (158°F).

3. Check 1st trip DTC.

Is 1st trip DTC detected?

- YES >> Go to [EC-233, "Diagnosis Procedure"](#).
NO >> INSPECTION END

TYPE B

1.PRECONDITIONING

If DTC Confirmation Procedure has been previously conducted, always perform the following before conducting the next test.

1. Turn ignition switch OFF and wait at least 10 seconds.
2. Turn ignition switch ON.
3. Turn ignition switch OFF and wait at least 10 seconds.

>> GO TO 2.

2.PERFORM DTC CONFIRMATION PROCEDURE-I

1. Clear the mixture ratio self-learning value. Refer to [EC-19, "MIXTURE RATIO SELF-LEARNING VALUE CLEAR : Special Repair Requirement"](#).
2. Start engine.

Is it difficult to start engine?

- YES >> GO TO 3.
NO >> GO TO 4.

3.RESTART ENGINE

If it is difficult to start engine, the fuel injection system has a malfunction, too.

P0172, P0175 FUEL INJECTION SYSTEM FUNCTION

[VQ35DE]

< COMPONENT DIAGNOSIS >

Crank engine while depressing accelerator pedal.

NOTE:

- When depressing accelerator pedal three-fourths (3/4) or more, the control system does not start the engine. Do not depress accelerator pedal too much.

Does engine start?

- YES >> Go to [EC-233, "Diagnosis Procedure"](#).
NO >> Check exhaust and intake air leakage visually.

4.PERFORM DTC CONFIRMATION PROCEDURE-II

1. Keep engine idle for at least 5 minutes.
2. Check 1st trip DTC.

Is 1st trip DTC detected?

- YES >> Go to [EC-233, "Diagnosis Procedure"](#).
NO >> GO TO 5.

5.PERFORM DTC CONFIRMATION PROCEDURE-III

1. Turn ignition switch OFF and wait at least 10 seconds.
2. Start engine.
3. Maintain the following conditions for at least 10 consecutive minutes.
Hold the accelerator pedal as steady as possible.

VHCL SPEED SE	50 - 120 km/h (31 - 75 mph)
---------------	-----------------------------

CAUTION:

Always drive vehicle at a safe speed.

4. Check 1st trip DTC.

Is 1st trip DTC detected?

- YES >> Go to [EC-233, "Diagnosis Procedure"](#).
NO >> INSPECTION END

Diagnosis Procedure

INFOID:000000003388018

1.CHECK EXHAUST GAS LEAKAGE

1. Start engine and run it at idle.
2. Listen for an exhaust gas leakage before three way catalyst (manifold).

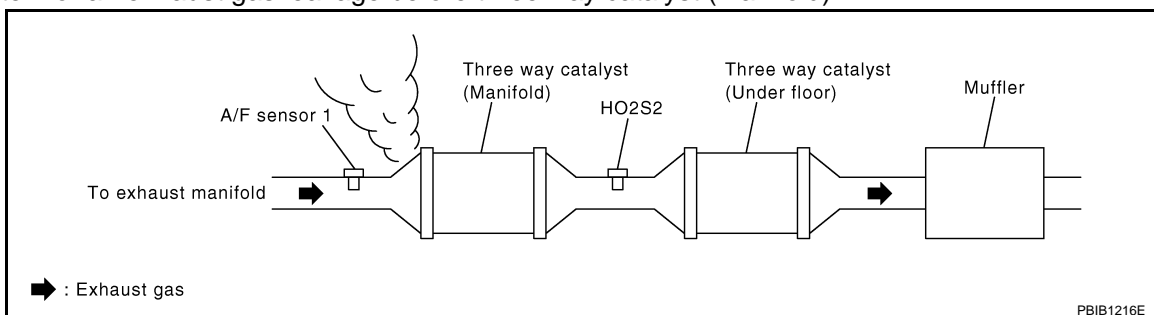

Is exhaust gas leakage detected?

- YES >> Repair or replace malfunctioning part.
NO >> GO TO 2.

2.CHECK FOR INTAKE AIR LEAKAGE

Listen for an intake air leakage after the mass air flow sensor.

Is intake air leakage detected?

- YES >> Repair or replace malfunctioning part.
NO >> GO TO 3.

3.CHECK A/F SENSOR 1 INPUT SIGNAL CIRCUIT

1. Turn ignition switch OFF.
2. Disconnect corresponding A/F sensor 1 harness connector.
3. Disconnect ECM harness connector.

P0172, P0175 FUEL INJECTION SYSTEM FUNCTION

[VQ35DE]

< COMPONENT DIAGNOSIS >

4. Check the continuity between A/F sensor 1 harness connector and ECM harness connector.

DTC	A/F sensor 1			ECM		Continuity
	Bank	Connector	Terminal	Connector	Terminal	
P0172	1	F27	1	F8	45	Existed
			2		49	
P0175	2	F64	1		53	
			2		57	

5. Check the continuity between A/F sensor 1 harness connector and ground, or ECM harness connector and ground.

DTC	A/F sensor 1			Ground	Continuity
	Bank	Connector	Terminal		
P0172	1	F27	1	Ground	Not existed
			2		
P0175	2	F64	1		
			2		

DTC	ECM		Ground	Continuity
	Connector	Terminal		
P0172	F8	45	Ground	Not existed
		49		
P0175		53		
		57		

6. Also check harness for short to power.

Is the inspection result normal?

YES >> GO TO 4.

NO >> Repair open circuit, short to ground or short to power in harness or connectors.

4. CHECK FUEL PRESSURE

1. Release fuel pressure to zero. Refer to [EC-545, "Inspection"](#).

2. Install fuel pressure gauge kit [SST (J-44321)] and check fuel pressure. Refer to [EC-545, "Inspection"](#).

At idling: Approximately 350 kPa (3.57 kg/cm², 51 psi)

Is the inspection result normal?

YES >> GO TO 5.

NO >> Replace "fuel filter and fuel pump assembly".

5. CHECK MASS AIR FLOW SENSOR

 **With CONSULT-III**

1. Install all removed parts.

2. Check "MASS AIR FLOW" in "DATA MONITOR" mode with CONSULT-III.

For specification, refer to [EC-551, "Mass Air Flow Sensor"](#).

 **With GST**

1. Install all removed parts.

2. Check mass air flow sensor signal in "Service \$01" with GST.

For specification, refer to [EC-551, "Mass Air Flow Sensor"](#).

Is the measurement value within the specification?

YES >> GO TO 6.

NO >> Check connectors for rusted terminals or loose connections in the mass air flow sensor circuit or ground. Refer to [EC-163, "Diagnosis Procedure"](#).

P0172, P0175 FUEL INJECTION SYSTEM FUNCTION

< COMPONENT DIAGNOSIS >

[VQ35DE]

6. CHECK FUNCTION OF FUEL INJECTOR

With CONSULT-III

1. Start engine.
2. Perform "POWER BALANCE" in "ACTIVE TEST" mode with CONSULT-III.
3. Check that each circuit produces a momentary engine speed drop.

With GST

1. Let engine idle.
2. Listen to each fuel injector operating sound.

Is the inspection result normal?

YES >> GO TO 7.

NO >> Perform trouble diagnosis for FUEL INJECTOR, refer to [EC-444, "Diagnosis Procedure"](#).

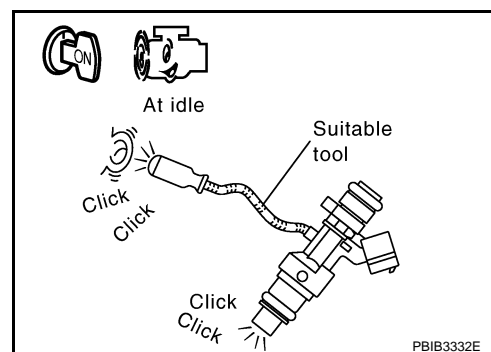

7. CHECK FUEL INJECTOR

1. Remove fuel injector assembly. Refer to [EM-45, "Removal and Installation"](#).
Keep fuel hose and all fuel injectors connected to fuel tube.
2. Confirm that the engine is cooled down and there are no fire hazards near the vehicle.
3. Disconnect all fuel injector harness connectors.
4. Disconnect all ignition coil harness connectors.
5. Prepare pans or saucers under each fuel injectors.
6. Crank engine for about 3 seconds.
Check fuel does not drip from fuel injector.

Is the inspection result normal?

YES >> GO TO 8.

NO >> Replace the fuel injectors from which fuel is dripping. Always replace O-ring with new one.

8. CHECK INTERMITTENT INCIDENT

Refer to [GI-40, "Intermittent Incident"](#).

>> INSPECTION END

P0181 FTT SENSOR

Description

INFOID:000000003388019

The fuel tank temperature sensor is used to detect the fuel temperature inside the fuel tank. The sensor modifies a voltage signal from the ECM. The modified signal returns to the ECM as the fuel temperature input. The sensor uses a thermistor which is sensitive to the change in temperature. The electrical resistance of the thermistor decreases as temperature increases.

<Reference data>

Fluid temperature [°C (°F)]	Voltage* (V)	Resistance (kΩ)
20 (68)	3.5	2.3 - 2.7
50 (122)	2.2	0.79 - 0.90

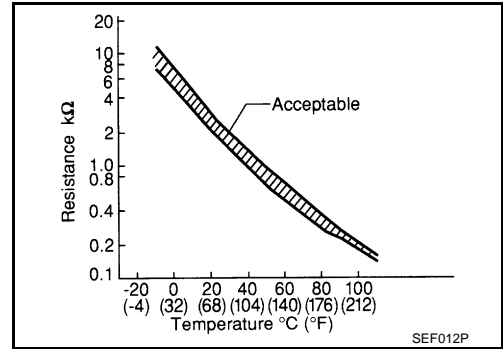

*: These data are reference values and are measured between ECM terminals 95 (Fuel tank temperature sensor) and ground.

DTC Logic

INFOID:000000003388020

DTC DETECTION LOGIC

DTC No.	Trouble diagnosis name	DTC detecting condition	Possible cause
P0181	Fuel tank temperature sensor circuit range/performance	Rationally incorrect voltage from the sensor is sent to ECM, compared with the voltage signals from engine coolant temperature sensor and intake air temperature sensor.	<ul style="list-style-type: none"> Harness or connectors (The sensor circuit is open or shorted) Fuel tank temperature sensor

DTC CONFIRMATION PROCEDURE

1. PRECONDITIONING

If DTC Confirmation Procedure has been previously conducted, always perform the following before conducting the next test.

- Turn ignition switch OFF and wait at least 10 seconds.
- Turn ignition switch ON.
- Turn ignition switch OFF and wait at least 10 seconds.

>> GO TO 2.

2. PERFORM DTC CONFIRMATION PROCEDURE-I

- Turn ignition switch ON and wait at least 10 seconds.
- Check 1st trip DTC.

Is 1st trip DTC detected?

- YES >> Go to [EC-237, "Diagnosis Procedure"](#).
- NO >> GO TO 3.

3. CHECK ENGINE COOLANT TEMPERATURE

With CONSULT-III

- Select "COOLAN TEMP/S" in "DATA MONITOR" with CONSULT-III.
- Check "COOLAN TEMP/S" value.

With GST

Follow the procedure "With CONSULT-III" above.

Is "COOLAN TEMP/S" less than 60°C (140°F)?

- YES >> INSPECTION END
- NO >> GO TO 4.

4. PERFORM DTC CONFIRMATION PROCEDURE-II

P0181 FTT SENSOR

[VQ35DE]

< COMPONENT DIAGNOSIS >

With CONSULT-III

1. Cool engine down until "COOLAN TEMP/S" is less than 60°C (140°F).
2. Wait at least 10 seconds.
3. Check 1st trip DTC.

With GST

Follow the procedure "With CONSULT-III" above.

Is 1st trip DTC detected?

- YES >> Go to [EC-237. "Diagnosis Procedure"](#).
 NO >> INSPECTION END

Diagnosis Procedure

INFOID:000000003388021

1. CHECK GROUND CONNECTION

1. Turn ignition switch OFF.
2. Check ground connection E38. Refer to Ground Inspection in [GI-43. "Circuit Inspection"](#).

Is the inspection result normal?

- YES >> GO TO 2.
 NO >> Repair or replace ground connection.

2. CHECK FUEL TANK TEMPERATURE SENSOR POWER SUPPLY CIRCUIT

1. Turn ignition switch OFF.
2. Disconnect "fuel level sensor unit and fuel pump" harness connector.
3. Turn ignition switch ON.
4. Check the voltage between "fuel level sensor unit and fuel pump" harness connector and ground.

Fuel level sensor unit and fuel pump		Ground	Voltage
Connector	Terminal		
B40	4	Ground	Approx. 5 V

Is the inspection result normal?

- YES >> GO TO 4.
 NO >> GO TO 3.

3. DETECT MALFUNCTIONING PART

Check the following.

- Harness connectors E104, B4
- Harness for open or short between ECM and "fuel level sensor unit and fuel pump"

>> Repair open circuit, short to ground or short to power in harness or connector.

4. CHECK FUEL TANK TEMPERATURE SENSOR GROUND CIRCUIT FOR OPEN AND SHORT

1. Turn ignition switch OFF.
2. Disconnect ECM harness connector.
3. Check the continuity between "fuel level sensor unit and fuel pump" harness connector and ECM harness connector.

Fuel level sensor unit and fuel pump		ECM		Continuity
Connector	Terminal	Connector	Terminal	
B40	5	E16	104	Existed

4. Also check harness for short to ground and short to power.

Is the inspection result normal?

- YES >> GO TO 6.
 NO >> GO TO 5.

5. DETECT MALFUNCTIONING PART

Check the following.

P0181 FTT SENSOR

[VQ35DE]

< COMPONENT DIAGNOSIS >

- Harness connectors E105, M11
- Harness connectors M77, B11
- Harness for open or short between “fuel level sensor unit and fuel pump” and ECM

>> Repair open circuit, short to ground or short to power in harness or connector.

6. CHECK FUEL TANK TEMPERATURE SENSOR

Refer to [EC-238, "Component Inspection"](#).

Is the inspection result normal?

YES >> GO TO 7.

NO >> Replace “fuel level sensor unit and fuel pump”.

7. CHECK INTERMITTENT INCIDENT

Refer to [GI-40, "Intermittent Incident"](#).

>> INSPECTION END

Component Inspection

INFOID:000000003388022

1. CHECK FUEL TANK TEMPERATURE SENSOR

1. Turn ignition switch OFF.
2. Remove fuel level sensor unit.
3. Check resistance between “fuel level sensor unit and fuel pump” terminals by heating with hot water as shown in the figure.

Terminals	Condition	Resistance	
4 and 5	Temperature [°C (°F)]	20 (68)	2.3 - 2.7 kΩ
		50 (122)	0.79 - 0.90 kΩ

Is the inspection result normal?

YES >> INSPECTION END

NO >> Replace “fuel level sensor unit and fuel pump”.

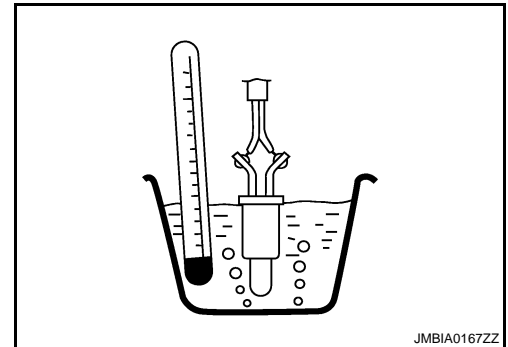

P0182, P0183 FTT SENSOR

Description

INFOID:000000003591617

The fuel tank temperature sensor is used to detect the fuel temperature inside the fuel tank. The sensor modifies a voltage signal from the ECM. The modified signal returns to the ECM as the fuel temperature input. The sensor uses a thermistor which is sensitive to the change in temperature. The electrical resistance of the thermistor decreases as temperature increases.

<Reference data>

Fluid temperature [°C (°F)]	Voltage* (V)	Resistance (kΩ)
20 (68)	3.5	2.3 - 2.7
50 (122)	2.2	0.79 - 0.90

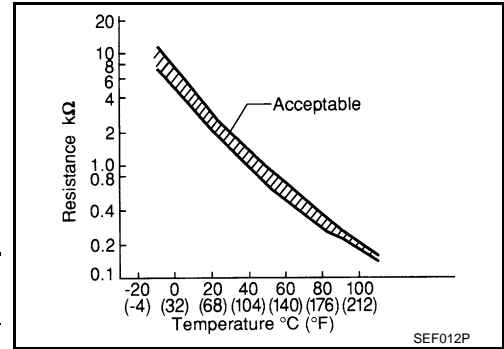

*: These data are reference values and are measured between ECM terminals 95 (Fuel tank temperature sensor) and ground.

DTC Logic

INFOID:000000003388024

DTC DETECTION LOGIC

DTC No.	Trouble diagnosis name	DTC detecting condition	Possible cause
P0182	Fuel tank temperature sensor circuit low input	An excessively low voltage from the sensor is sent to ECM.	<ul style="list-style-type: none"> • Harness or connectors (The sensor circuit is open or shorted.) • Fuel tank temperature sensor
P0183	Fuel tank temperature sensor circuit high input	An excessively high voltage from the sensor is sent to ECM.	

DTC CONFIRMATION PROCEDURE

1. PRECONDITIONING

If DTC Confirmation Procedure has been previously conducted, always perform the following before conducting the next test.

1. Turn ignition switch OFF and wait at least 10 seconds.
2. Turn ignition switch ON.
3. Turn ignition switch OFF and wait at least 10 seconds.

>> GO TO 2.

2. PERFORM DTC CONFIRMATION PROCEDURE

1. Turn ignition switch ON and wait at least 5 seconds.
2. Check 1st trip DTC.

Is 1st trip DTC detected?

- YES >> Go to [EC-239, "Diagnosis Procedure"](#).
- NO >> INSPECTION END

Diagnosis Procedure

INFOID:000000003591618

1. CHECK GROUND CONNECTION

1. Turn ignition switch OFF.
2. Check ground connection E38. Refer to Ground Inspection in [GI-43, "Circuit Inspection"](#).

Is the inspection result normal?

- YES >> GO TO 2.
- NO >> Repair or replace ground connection.

2. CHECK FUEL TANK TEMPERATURE SENSOR POWER SUPPLY CIRCUIT

1. Turn ignition switch OFF.

P0182, P0183 FTT SENSOR

[VQ35DE]

< COMPONENT DIAGNOSIS >

2. Disconnect "fuel level sensor unit and fuel pump" harness connector.
3. Turn ignition switch ON.
4. Check the voltage between "fuel level sensor unit and fuel pump" harness connector and ground.

Fuel level sensor unit and fuel pump		Ground	Voltage
Connector	Terminal		
B40	4	Ground	Approx. 5 V

Is the inspection result normal?

YES >> GO TO 4.

NO >> GO TO 3.

3.DETECT MALFUNCTIONING PART

Check the following.

- Harness connectors E104, B4
- Harness for open or short between ECM and "fuel level sensor unit and fuel pump"

>> Repair open circuit, short to ground or short to power in harness or connector.

4.CHECK FUEL TANK TEMPERATURE SENSOR GROUND CIRCUIT FOR OPEN AND SHORT

1. Turn ignition switch OFF.
2. Disconnect ECM harness connector.
3. Check the continuity between "fuel level sensor unit and fuel pump" harness connector and ECM harness connector.

Fuel level sensor unit and fuel pump		ECM		Continuity
Connector	Terminal	Connector	Terminal	
B40	5	E16	104	Existed

4. Also check harness for short to ground and short to power.

Is the inspection result normal?

YES >> GO TO 6.

NO >> GO TO 5.

5.DETECT MALFUNCTIONING PART

Check the following.

- Harness connectors E105, M11
- Harness connectors M77, B11
- Harness for open or short between "fuel level sensor unit and fuel pump" and ECM

>> Repair open circuit, short to ground or short to power in harness or connector.

6.CHECK FUEL TANK TEMPERATURE SENSOR

Refer to [EC-240, "Component Inspection"](#).

Is the inspection result normal?

YES >> GO TO 7.

NO >> Replace "fuel level sensor unit and fuel pump".

7.CHECK INTERMITTENT INCIDENT

Refer to [GI-40, "Intermittent Incident"](#).

>> INSPECTION END

Component Inspection

INFOID:000000003591619

1.CHECK FUEL TANK TEMPERATURE SENSOR

1. Turn ignition switch OFF.

P0182, P0183 FTT SENSOR

[VQ35DE]

< COMPONENT DIAGNOSIS >

2. Remove fuel level sensor unit.
3. Check resistance between “fuel level sensor unit and fuel pump” terminals by heating with hot water as shown in the figure.

Terminals	Condition	Resistance
4 and 5	Temperature [°C (°F)]	20 (68)
		50 (122)
		2.3 - 2.7 kΩ
		0.79 - 0.90 kΩ

Is the inspection result normal?

YES >> INSPECTION END

NO >> Replace “fuel level sensor unit and fuel pump”.

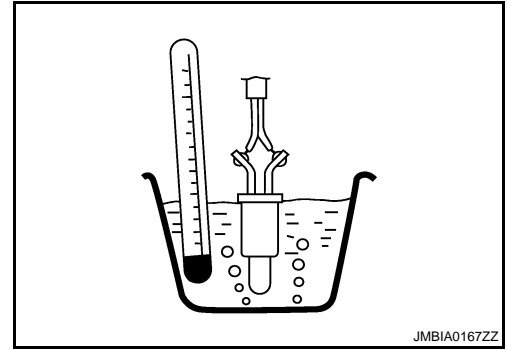

A

EC

C

D

E

F

G

H

I

J

K

L

M

N

O

P

P0196 EOT SENSOR

Description

INFOID:000000003544688

The engine oil temperature sensor is used to detect the engine oil temperature. The sensor modifies a voltage signal from the ECM. The modified signal returns to the ECM as the engine oil temperature input. The sensor uses a thermistor which is sensitive to the change in temperature. The electrical resistance of the thermistor decreases as temperature increases.

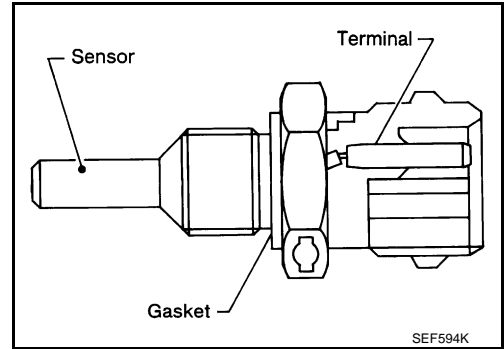

<Reference data>

Engine oil temperature [°C (°F)]	Voltage* (V)	Resistance (kΩ)
-10 (14)	4.4	7.0 - 11.4
20 (68)	3.5	2.1 - 2.9
50 (122)	2.2	0.68 - 1.00
90 (194)	0.9	0.236 - 0.260
110 (230)	0.6	0.143 - 0.153

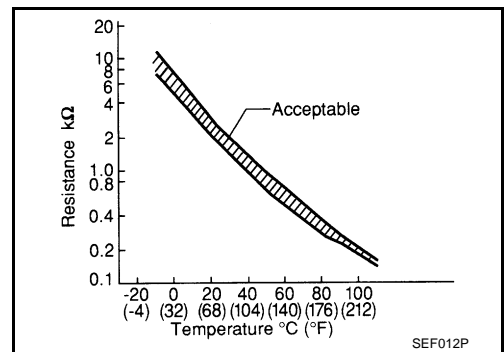

*: These data are reference values and are measured between ECM terminals 54 (Engine oil temperature sensor) and 52 (Sensor ground).

DTC Logic

INFOID:000000003544689

DTC DETECTION LOGIC

NOTE:

If DTC P0196 is displayed with P0197 or P0198, first perform the trouble diagnosis for DTC P0197, P0198. Refer to [EC-245, "DTC Logic"](#).

DTC No.	Trouble diagnosis name	DTC detecting condition	Possible cause
P0196	Engine oil temperature sensor range/performance	Rationally incorrect voltage from the sensor is sent to ECM, compared with the voltage signals from engine coolant temperature sensor and intake air temperature sensor.	<ul style="list-style-type: none"> • Harness or connectors (The sensor circuit is open or shorted) • Engine oil temperature sensor

DTC CONFIRMATION PROCEDURE

1. PRECONDITIONING

If DTC Confirmation Procedure has been previously conducted, always perform the following before conducting the next test.

1. Turn ignition switch OFF and wait at least 10 seconds.
2. Turn ignition switch ON.
3. Turn ignition switch OFF and wait at least 10 seconds.

TESTING CONDITION:

Before performing the following procedure, confirm that battery voltage is more than 11 V at idle.

>> GO TO 2.

2. PERFORM DTC CONFIRMATION PROCEDURE-I

1. Start engine and warm it up to normal operating temperature.
2. Turn ignition switch OFF and wait at least 10 seconds.

< COMPONENT DIAGNOSIS >

3. Turn ignition switch ON.
4. Turn ignition switch OFF and wait at least 10 seconds.
5. Start engine and let it idle for 5 minutes and 10 seconds.
6. Check 1st trip DTC.

Is 1st trip DTC detected?

- YES >> [EC-243, "Diagnosis Procedure"](#).
 NO >> GO TO 3.

3.PERFORM DTC CONFIRMATION PROCEDURE-II

Ⓜ With CONSULT-III

1. Select "DATA MONITOR" mode with CONSULT-III.
 2. Check that "COOLAN TEMP/S" indicates above 80°C (176°F).
 If it is above 80°C (176°F), go to the following steps.
 If it is below 80°C (176°F), warm engine up until "COOLAN TEMP/S" indicates more than 80°C (176°F).
 Then perform the following steps.
 3. Turn ignition switch OFF and soak the vehicle in a cool place.
 4. Turn ignition switch ON.
- NOTE:**
Do not turn ignition switch OFF until step 8.
5. Select "DATA MONITOR" mode with CONSULT-III.
 6. Check the following.

COOLAN TEMP/S	Below 40°C (104°F)
INT/A TEMP SE	Below 40°C (104°F)
Difference between "COOLAN TEMP/S" and "INT/A TEMP SE"	Within 6°C (11°F)

If they are within the specified range, perform the following steps.
 If they are out of the specified range, soak the vehicle to meet the above conditions. Then perform the following steps.

NOTE:

- Do not turn ignition switch OFF.
- If it is supposed to need a long period of time, do not deplete the battery.

7. Start engine and let it idle for 5 minutes.
8. Check 1st trip DTC.

Ⓜ With GST

Follow the procedure "With CONSULT-III" above.

Is 1st trip DTC detected?

- YES >> [EC-243, "Diagnosis Procedure"](#).
 NO >> INSPECTION END

Diagnosis Procedure

INFOID:000000003544690

1.CHECK GROUND CONNECTION

1. Turn ignition switch OFF.
2. Check ground connection E38. Refer to Ground Inspection in [GI-43, "Circuit Inspection"](#).

Is the inspection result normal?

- YES >> GO TO 2.
 NO >> Repair or replace ground connection.

2.CHECK ENGINE OIL TEMPERATURE SENSOR

Refer to [EC-244, "Component Inspection"](#).

Is the inspection result normal?

- YES >> GO TO 3.
 NO >> Replace engine oil temperature sensor.

3.CHECK INTERMITTENT INCIDENT

Refer to [GI-40, "Intermittent Incident"](#).

P0196 EOT SENSOR

[VQ35DE]

< COMPONENT DIAGNOSIS >

>> INSPECTION END

Component Inspection

INFOID:000000003544691

1. CHECK ENGINE OIL TEMPERATURE SENSOR

1. Turn ignition switch OFF.
2. Disconnect engine oil temperature sensor harness connector.
3. Remove engine oil temperature sensor.
4. Check resistance between engine oil temperature sensor terminals by heating with hot water as shown in the figure.

Terminals	Condition	Resistance	
1 and 2	Temperature [°C (°F)]	20 (68)	2.1 - 2.9 kΩ
		50 (122)	0.68 - 1.00 kΩ
		90 (194)	0.236 - 0.260 kΩ

Is the inspection result normal?

YES >> INSPECTION END

NO >> Replace engine oil temperature sensor.

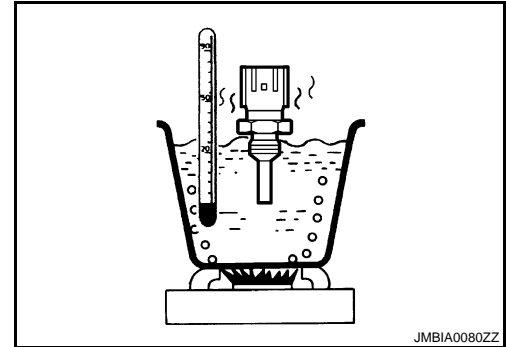

P0197, P0198 EOT SENSOR

< COMPONENT DIAGNOSIS >

[VQ35DE]

P0197, P0198 EOT SENSOR

Description

INFOID:000000003668898

The engine oil temperature sensor is used to detect the engine oil temperature. The sensor modifies a voltage signal from the ECM. The modified signal returns to the ECM as the engine oil temperature input. The sensor uses a thermistor which is sensitive to the change in temperature. The electrical resistance of the thermistor decreases as temperature increases.

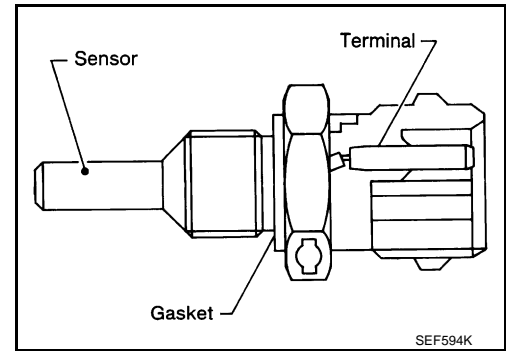

<Reference data>

Engine oil temperature [°C (°F)]	Voltage* (V)	Resistance (kΩ)
-10 (14)	4.4	7.0 - 11.4
20 (68)	3.5	2.1 - 2.9
50 (122)	2.2	0.68 - 1.00
90 (194)	0.9	0.236 - 0.260
110 (230)	0.6	0.143 - 0.153

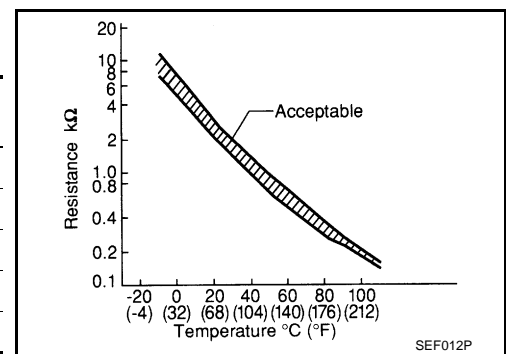

*: These data are reference values and are measured between ECM terminals 54 (Engine oil temperature sensor) and 52 (Sensor ground).

DTC Logic

INFOID:000000003544693

DTC DETECTION LOGIC

DTC No.	Trouble Diagnosis Name	DTC detecting condition	Possible Cause
P0197	Engine oil temperature sensor circuit low input	An excessively low voltage from the sensor is sent to ECM.	<ul style="list-style-type: none"> • Harness or connectors (The sensor circuit is open or shorted.) • Engine oil temperature sensor
P0198	Engine oil temperature sensor circuit high input	An excessively high voltage from the sensor is sent to ECM.	

DTC CONFIRMATION PROCEDURE

1. PRECONDITIONING

If DTC Confirmation Procedure has been previously conducted, always perform the following before conducting the next test.

1. Turn ignition switch OFF and wait at least 10 seconds.
2. Turn ignition switch ON.
3. Turn ignition switch OFF and wait at least 10 seconds.

>> GO TO 2.

2. PERFORM DTC CONFIRMATION PROCEDURE

1. Start engine and wait at least 5 seconds.
2. Check 1st trip DTC.

Is 1st trip DTC detected?

P0197, P0198 EOT SENSOR

[VQ35DE]

< COMPONENT DIAGNOSIS >

- YES >> Go to [EC-246, "Diagnosis Procedure"](#).
NO >> INSPECTION END

Diagnosis Procedure

INFOID:000000003544694

1. CHECK GROUND CONNECTION

1. Turn ignition switch OFF.
2. Check ground connection E38. Refer to Ground Inspection in [GI-43, "Circuit Inspection"](#).

Is the inspection result normal?

- YES >> GO TO 2.
NO >> Repair or replace ground connection.

2. CHECK EOT SENSOR POWER SUPPLY CIRCUIT

1. Disconnect engine oil temperature (EOT) sensor harness connector.
2. Turn ignition switch ON.
3. Check the voltage between EOT sensor harness connector and ground.

EOT sensor		Ground	Voltage
Connector	Terminal		
F66	1	Ground	Approx. 5 V

Is the inspection result normal?

- YES >> GO TO 3.
NO >> Repair open circuit, short to ground or short to power in harness or connectors.

3. CHECK EOT SENSOR GROUND CIRCUIT FOR OPEN AND SHORT

1. Turn ignition switch OFF.
2. Disconnect ECM harness connector.
3. Check the continuity between EOT sensor harness connector and ECM harness connector.

EOT sensor		ECM		Continuity
Connector	Terminal	Connector	Terminal	
F66	2	F8	52	Existed

4. Also check harness for short to ground and short to power.

Is the inspection result normal?

- YES >> GO TO 4.
NO >> Repair open circuit, short to ground or short to power in harness or connectors.

4. CHECK ENGINE OIL TEMPERATURE SENSOR

Refer to [EC-246, "Component Inspection"](#).

Is the inspection result normal?

- YES >> GO TO 5.
NO >> Replace engine oil temperature sensor.

5. CHECK INTERMITTENT INCIDENT

Refer to [GI-40, "Intermittent Incident"](#).

>> INSPECTION END

Component Inspection

INFOID:000000003668899

1. CHECK ENGINE OIL TEMPERATURE SENSOR

1. Turn ignition switch OFF.
2. Disconnect engine oil temperature sensor harness connector.
3. Remove engine oil temperature sensor.

P0197, P0198 EOT SENSOR

[VQ35DE]

< COMPONENT DIAGNOSIS >

4. Check resistance between engine oil temperature sensor terminals by heating with hot water as shown in the figure.

Terminals	Condition	Resistance	
1 and 2	Temperature [°C (°F)]	20 (68)	2.1 - 2.9 kΩ
		50 (122)	0.68 - 1.00 kΩ
		90 (194)	0.236 - 0.260 kΩ

Is the inspection result normal?

YES >> INSPECTION END

NO >> Replace engine oil temperature sensor.

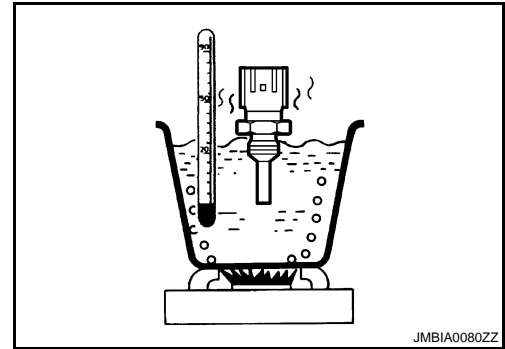

A

EC

C

D

E

F

G

H

I

J

K

L

M

N

O

P

P0222, P0223 TP SENSOR

Description

INFOID:000000003591571

Electric throttle control actuator consists of throttle control motor, throttle position sensor, etc. The throttle position sensor responds to the throttle valve movement.

The throttle position sensor has two sensors. These sensors are a kind of potentiometer which transform the throttle valve position into output voltage, and emit the voltage signals to the ECM. The ECM judges the current opening angle of the throttle valve from these signals and controls the throttle valve opening angle in response to driving conditions via the throttle control motor.

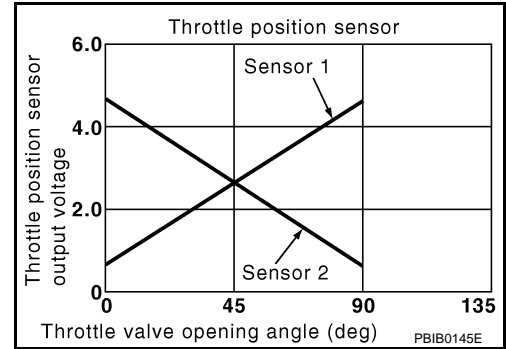

DTC Logic

INFOID:000000003388028

DTC DETECTION LOGIC

NOTE:

If DTC P0222 or P0223 is displayed with DTC P0643, first perform the trouble diagnosis for DTC P0643. Refer to [EC-347, "DTC Logic"](#).

DTC No.	Trouble diagnosis name	DTC detecting condition	Possible cause
P0222	Throttle position sensor 1 circuit low input	An excessively low voltage from the TP sensor 1 is sent to ECM.	<ul style="list-style-type: none"> Harness or connectors (TP sensor 1 circuit is open or shorted.)
P0223	Throttle position sensor 1 circuit high input	An excessively high voltage from the TP sensor 1 is sent to ECM.	<ul style="list-style-type: none"> Electric throttle control actuator (TP sensor 1)

DTC CONFIRMATION PROCEDURE

1. PRECONDITIONING

If DTC Confirmation Procedure has been previously conducted, always perform the following before conducting the next test.

- Turn ignition switch OFF and wait at least 10 seconds.
- Turn ignition switch ON.
- Turn ignition switch OFF and wait at least 10 seconds.

TESTING CONDITION:

Before performing the following procedure, confirm that battery voltage is more than 10 V at idle.

>> GO TO 2.

2. PERFORM DTC CONFIRMATION PROCEDURE

- Start engine and let it idle for 1 second.
- Check DTC.

Is DTC detected?

- YES >> Go to [EC-248, "Diagnosis Procedure"](#).
- NO >> INSPECTION END

Diagnosis Procedure

INFOID:000000003388029

1. CHECK GROUND CONNECTION

- Turn ignition switch OFF.
- Check ground connection E38. Refer to Ground Inspection in [GI-43, "Circuit Inspection"](#).

Is the inspection result normal?

- YES >> GO TO 2.
- NO >> Repair or replace ground connection.

P0222, P0223 TP SENSOR

[VQ35DE]

< COMPONENT DIAGNOSIS >

2. CHECK THROTTLE POSITION SENSOR 1 POWER SUPPLY CIRCUIT-I

1. Disconnect electric throttle control actuator harness connector.
2. Turn ignition switch ON.
3. Check the voltage between electric throttle control actuator harness connector and ground.

Electric throttle control actuator		Ground	Voltage
Connector	Terminal		
F29	1	Ground	Approx. 5 V

Is the inspection result normal?

YES >> GO TO 3.

NO >> Repair open circuit, short to ground or short to power in harness or connectors.

3. CHECK THROTTLE POSITION SENSOR 1 GROUND CIRCUIT FOR OPEN AND SHORT

1. Turn ignition switch OFF.
2. Disconnect ECM harness connector.
3. Check the continuity between electric throttle control actuator and ECM harness connector.

Electric throttle control actuator		ECM		Continuity
Connector	Terminal	Connector	Terminal	
F29	4	F8	36	Existed

4. Also check harness for short to ground and short to power.

Is the inspection result normal?

YES >> GO TO 4.

NO >> Repair open circuit, short to ground or short to power in harness or connectors.

4. CHECK THROTTLE POSITION SENSOR 1 INPUT SIGNAL CIRCUIT FOR OPEN AND SHORT

1. Check the continuity between electric throttle control actuator and ECM harness connector.

Electric throttle control actuator		ECM		Continuity
Connector	Terminal	Connector	Terminal	
F29	2	F8	37	Existed

2. Also check harness for short to ground and short to power.

Is the inspection result normal?

YES >> GO TO 5.

NO >> Repair open circuit, short to ground or short to power in harness or connectors.

5. CHECK THROTTLE POSITION SENSOR

Refer to [EC-250, "Component Inspection"](#).

Is the inspection result normal?

YES >> GO TO 7.

NO >> GO TO 6.

6. REPLACE ELECTRIC THROTTLE CONTROL ACTUATOR

1. Replace electric throttle control actuator.
2. Refer to [EC-250, "Special Repair Requirement"](#).

>> INSPECTION END

7. CHECK INTERMITTENT INCIDENT

Refer to [GI-40, "Intermittent Incident"](#).

>> INSPECTION END

Component Inspection

INFOID:000000003597479

1. CHECK THROTTLE POSITION SENSOR

1. Turn ignition switch OFF.
2. Reconnect all harness connectors disconnected.
3. Perform [EC-17, "THROTTLE VALVE CLOSED POSITION LEARNING : Special Repair Requirement"](#).
4. Turn ignition switch ON.
5. Set selector lever to D position.
6. Check the voltage between ECM harness connector terminals under the following conditions.

ECM			Condition	Voltage
Connector	+	-		
	Terminal	Terminal		
F8	37 (TP sensor 1 signal)	36 (Sensor ground)	Fully released	More than 0.36 V
			Fully depressed	Less than 4.75 V
	38 (TP sensor 2 signal)		Fully released	Less than 4.75 V
			Fully depressed	More than 0.36 V

Is the inspection result normal?

- YES >> INSPECTION END
 NO >> GO TO 2.

2. REPLACE ELECTRIC THROTTLE CONTROL ACTUATOR

1. Replace electric throttle control actuator.
2. Go to [EC-177, "Special Repair Requirement"](#).

>> INSPECTION END

Special Repair Requirement

INFOID:000000003591585

1. PERFORM THROTTLE VALVE CLOSED POSITION LEARNING

Refer to [EC-17, "THROTTLE VALVE CLOSED POSITION LEARNING : Special Repair Requirement"](#)

>> GO TO 2.

2. PERFORM IDLE AIR VOLUME LEARNING

Refer to [EC-17, "IDLE AIR VOLUME LEARNING : Special Repair Requirement"](#)

>> END

P0300, P0301, P0302, P0303, P0304, P0305, P0306 MISFIRE

< COMPONENT DIAGNOSIS >

[VQ35DE]

P0300, P0301, P0302, P0303, P0304, P0305, P0306 MISFIRE

DTC Logic

INFOID:000000003388032

DTC DETECTION LOGIC

When a misfire occurs, engine speed will fluctuate. If the engine speed fluctuates enough to cause the crankshaft position (CKP) sensor (POS) signal to vary, ECM can determine that a misfire is occurring.

Sensor	Input signal to ECM	ECM function
Crankshaft position sensor (POS)	Engine speed	On board diagnosis of misfire

The misfire detection logic consists of the following two conditions.

- One Trip Detection Logic (Three Way Catalyst Damage)**
On the 1st trip, when a misfire condition occurs that can damage the three way catalyst (TWC) due to overheating, the MIL will blink.
When a misfire condition occurs, the ECM monitors the CKP sensor signal every 200 engine revolutions for a change.
When the misfire condition decreases to a level that will not damage the TWC, the MIL will turn off.
If another misfire condition occurs that can damage the TWC on a second trip, the MIL will blink.
When the misfire condition decreases to a level that will not damage the TWC, the MIL will remain on.
If another misfire condition occurs that can damage the TWC, the MIL will begin to blink again.
- Two Trip Detection Logic (Exhaust quality deterioration)**
For misfire conditions that will not damage the TWC (but will affect vehicle emissions), the MIL will only illuminate when the misfire is detected on a second trip. During this condition, the ECM monitors the CKP sensor signal every 1,000 engine revolutions.
A misfire malfunction can be detected in any one cylinder or in multiple cylinders.

DTC No.	Trouble diagnosis name	DTC detecting condition	Possible cause
P0300	Multiple cylinder misfires detected	Multiple cylinders misfire.	<ul style="list-style-type: none">• Improper spark plug• Insufficient compression• Incorrect fuel pressure• The fuel injector circuit is open or shorted• Fuel injector• Intake air leakage• The ignition signal circuit is open or shorted• Lack of fuel• Signal plate• A/F sensor 1• Incorrect PCV hose connection
P0301	No. 1 cylinder misfire detected	No. 1 cylinder misfires.	
P0302	No. 2 cylinder misfire detected	No. 2 cylinder misfires.	
P0303	No. 3 cylinder misfire detected	No. 3 cylinder misfires.	
P0304	No. 4 cylinder misfire detected	No. 4 cylinder misfires.	
P0305	No. 5 cylinder misfire detected	No. 5 cylinder misfires.	
P0306	No. 6 cylinder misfire detected	No. 6 cylinder misfires.	

DTC CONFIRMATION PROCEDURE

1. PRECONDITIONING

If DTC Confirmation Procedure has been previously conducted, always perform the following procedure before conducting the next test.

1. Turn ignition switch OFF and wait at least 10 seconds.
2. Turn ignition switch ON.
3. Turn ignition switch OFF and wait at least 10 seconds.

>> GO TO 2.

2. PERFORM DTC CONFIRMATION PROCEDURE-I

1. Start engine and warm it up to normal operating temperature.
2. Turn ignition switch OFF and wait at least 10 seconds.
3. Turn ignition switch ON.
4. Turn ignition switch OFF and wait at least 10 seconds.
5. Restart engine and let it idle for approximately 15 minutes.
6. Check 1st trip DTC.

Is 1st trip DTC detected?

- YES >> Go to [EC-252, "Diagnosis Procedure"](#).
- NO >> GO TO 3.

3.PERFORM DTC CONFIRMATION PROCEDURE-II

1. Turn ignition switch OFF and wait at least 10 seconds.
2. Turn ignition switch ON.
3. Turn ignition switch OFF and wait at least 10 seconds.
4. Start engine and drive the vehicle under similar conditions to (1st trip) Freeze Frame Data for a certain time. Refer to the table below.

Hold the accelerator pedal as steady as possible.

Similar conditions to (1st trip) Freeze Frame Data mean that the following conditions should be satisfied at the same time.

CAUTION:

Always drive vehicle in safe manner according to traffic conditions and obey all traffic laws when driving.

Engine speed	Engine speed in the freeze frame data \pm 400 rpm
Vehicle speed	Vehicle speed in the freeze frame data \pm 10 km/h (6 MPH)
Basic fuel schedule	Basic fuel schedule in freeze frame data \times (1 \pm 0.1)
Engine coolant temperature (T) condition	When the freeze frame data shows lower than 70°C (158°F), T should be lower than 70°C (158°F).
	When the freeze frame data shows higher than or equal to 70°C (158°F), T should be higher than or equal to 70°C (158°F).

Driving time varies according to the engine speed in the freeze frame data.

Engine speed	Time
Around 1,000 rpm	Approximately 10 minutes
Around 2,000 rpm	Approximately 5 minutes
More than 3,000 rpm	Approximately 3.5 minutes

5. Check 1st trip DTC.

Is 1st trip DTC detected?

- YES >> Go to [EC-252, "Diagnosis Procedure"](#).
- NO >> INSPECTION END

Diagnosis Procedure

INFOID:000000003388033

1.CHECK FOR INTAKE AIR LEAKAGE AND PCV HOSE

1. Start engine and run it at idle speed.
2. Listen for the sound of the intake air leakage.
3. Check PCV hose connection.

Is intake air leakage detected?

- YES >> Discover air leakage location and repair.
- NO >> GO TO 2.

2.CHECK FOR EXHAUST SYSTEM CLOGGING

Stop engine and visually check exhaust tube, three way catalyst and muffler for dents.

Is the inspection result normal?

- YES-1 >> With CONSULT-III: GO TO 3.
- YES-2 >> Without CONSULT-III: GO TO 4.
- NO >> Repair or replace malfunctioning part.

3.PERFORM POWER BALANCE TEST

Ⓜ With CONSULT-III

1. Start engine.
2. Perform "POWER BALANCE" in "ACTIVE TEST" mode with CONSULT-III.

P0300, P0301, P0302, P0303, P0304, P0305, P0306 MISFIRE

[VQ35DE]

< COMPONENT DIAGNOSIS >

3. Check that each circuit produces a momentary engine speed drop.

Is the inspection result normal?

- YES >> GO TO 9.
- NO >> GO TO 4.

4.CHECK FUNCTION OF FUEL INJECTOR

1. Start engine and let it idle.
2. Listen to each fuel injector make operation sound.

Clicking sound should be heard.

Is the inspection result normal?

- YES >> GO TO 5.
- NO >> Perform trouble diagnosis for FUEL INJECTOR, refer to [EC-444. "Diagnosis Procedure"](#).

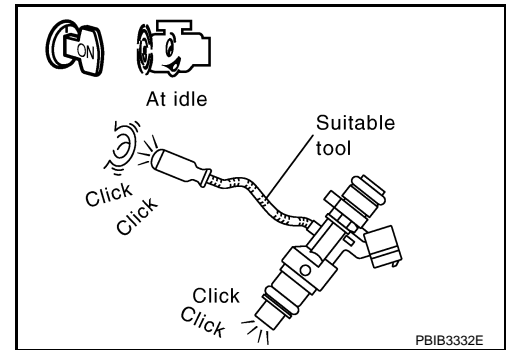

5.CHECK FUNCTION OF IGNITION COIL-I

CAUTION:

Perform the following procedure in a place with no combustible objects and good ventilation.

1. Turn ignition switch OFF.
2. Remove fuel pump fuse in IPDM E/R to release fuel pressure.

NOTE:

Do not use CONSULT-III to release fuel pressure, or fuel pressure applies again during the following procedure.

3. Start engine.
4. After engine stalls, crank it 2 or 3 times to release all fuel pressure.
5. Turn ignition switch OFF.
6. Remove all ignition coil harness connectors to avoid the electrical discharge from the ignition coils.
7. Remove ignition coil and spark plug of the cylinder to be checked.
8. Crank engine for 5 seconds or more to remove combustion gas in the cylinder.
9. Connect spark plug and harness connector to ignition coil.
10. Fix ignition coil using a rope etc. with gap of 13 - 17 mm (0.52 - 0.66 in) between the edge of the spark plug and grounded metal portion as shown in the figure.
11. Crank engine for approximately 3 seconds, and check whether spark is generated between the spark plug and the grounded metal portion.

Spark should be generated.

CAUTION:

- During the operation, always stay 0.5 m (19.7 in) or more away from the spark plug and the ignition coil. Be careful not to get an electrical shock while checking, because the electrical discharge voltage becomes 20 kV or more.
- It might damage the ignition coil if the gap of more than 17 mm (0.66 in) is made.

NOTE:

When the gap is less than 13 mm (0.52 in), a spark might be generated even if the coil is malfunctioning.

Is the inspection result normal?

- YES >> GO TO 9.
- NO >> GO TO 6.

6.CHECK FUNCTION OF IGNITION COIL-II

1. Turn ignition switch OFF.
2. Disconnect spark plug and connect a non-malfunctioning spark plug.

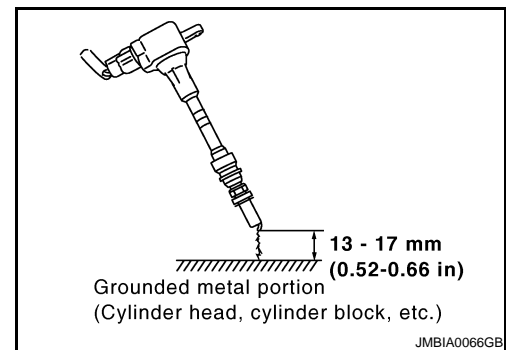

P0300, P0301, P0302, P0303, P0304, P0305, P0306 MISFIRE

< COMPONENT DIAGNOSIS >

[VQ35DE]

3. Crank engine for approximately 3 seconds, and recheck whether spark is generated between the spark plug and the grounded metal portion.

Spark should be generated.

Is the inspection result normal?

YES >> GO TO 7.

NO >> Check ignition coil, power transistor and their circuits. Refer to [EC-451, "Diagnosis Procedure"](#).

7.CHECK SPARK PLUG

Check the initial spark plug for fouling, etc.

Is the inspection result normal?

YES >> Replace spark plug(s) with standard type one(s). For spark plug type, refer to [EM-142, "Spark Plug"](#).

NO >> Repair or clean spark plug. Then GO TO 8.

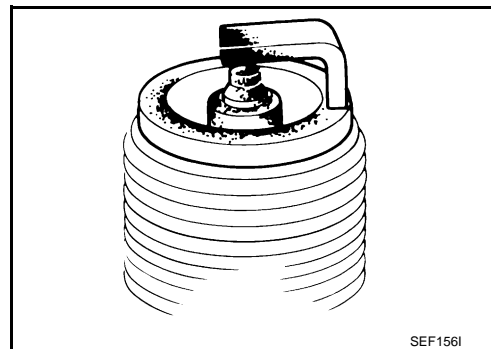

8.CHECK FUNCTION OF IGNITION COIL-III

1. Reconnect the initial spark plugs.
2. Crank engine for approximately 3 seconds, and recheck whether spark is generated between the spark plug and the grounded portion.

Spark should be generated.

Is the inspection result normal?

YES >> INSPECTION END

NO >> Replace spark plug(s) with standard type one(s). For spark plug type, refer to [EM-142, "Spark Plug"](#).

9.CHECK COMPRESSION PRESSURE

Check compression pressure. Refer to [EM-23, "Inspection"](#).

Is the inspection result normal?

YES >> GO TO 10.

NO >> Check pistons, piston rings, valves, valve seats and cylinder head gaskets.

10.CHECK FUEL PRESSURE

1. Install all removed parts.
2. Release fuel pressure to zero. Refer to [EC-545, "Inspection"](#).
3. Install fuel pressure gauge kit [SST (J-44321)] and check fuel pressure. Refer to [EC-545, "Inspection"](#).

At idle: Approximately 350 kPa (3.57 kg/cm², 51 psi)

Is the inspection result normal?

YES >> GO TO 12.

NO >> GO TO 11.

11.DETECT MALFUNCTIONING PART

Check fuel hoses and fuel tubes for clogging.

Is the inspection result normal?

YES >> Replace "fuel filter and fuel pump assembly".

NO >> Repair or replace malfunctioning part.

12.CHECK IGNITION TIMING

Check idle speed and ignition timing.

For procedure, refer to [EC-12, "BASIC INSPECTION : Special Repair Requirement"](#).

P0300, P0301, P0302, P0303, P0304, P0305, P0306 MISFIRE

[VQ35DE]

< COMPONENT DIAGNOSIS >

For specification, refer to [EC-551, "Idle Speed"](#) and [EC-551, "Ignition Timing"](#).

Is the inspection result normal?

YES >> GO TO 13.

NO >> Follow the [EC-12, "BASIC INSPECTION : Special Repair Requirement"](#).

13.CHECK A/F SENSOR 1 INPUT SIGNAL CIRCUIT

1. Turn ignition switch OFF.
2. Disconnect corresponding A/F sensor 1 harness connector.
3. Disconnect ECM harness connector.
4. Check the continuity between A/F sensor 1 harness connector and ECM harness connector.

A/F sensor 1			ECM		Continuity
Bank	Connector	Terminal	Connector	Terminal	
1	F27	1	F8	45	Existed
		2		49	
2	F64	1		53	
		2		57	

5. Check the continuity between A/F sensor 1 harness connector and ground, or ECM harness connector and ground.

A/F sensor 1			Ground	Continuity
Bank	Connector	Terminal		
1	F27	1	Ground	Not existed
		2		
2	F64	1		
		2		

ECM		Ground	Continuity
Connector	Terminal		
F8	45	Ground	Not existed
	49		
	53		
	57		

6. Also check harness for short to power.

Is the inspection result normal?

YES >> GO TO 14.

NO >> Repair open circuit, short to ground or short to power in harness or connectors.

14.CHECK A/F SENSOR 1 HEATER

Refer to [EC-147, "Component Inspection"](#).

Is the inspection result normal?

YES >> GO TO 15.

NO >> Replace malfunctioning A/F sensor 1.

15.CHECK MASS AIR FLOW SENSOR

With CONSULT-III

1. Check "MASS AIR FLOW" in "DATA MONITOR" mode with CONSULT-III.
2. For specification, refer to [EC-551, "Mass Air Flow Sensor"](#).

With GST

1. Check mass air flow sensor signal in Service \$01 with GST.
2. For specification, refer to [EC-551, "Mass Air Flow Sensor"](#).

P0300, P0301, P0302, P0303, P0304, P0305, P0306 MISFIRE

< COMPONENT DIAGNOSIS >

[VQ35DE]

Is the measurement value within the specification?

YES >> GO TO 16.

NO >> Check connectors for rusted terminals or loose connections in the mass air flow sensor circuit or ground. Refer to [EC-163, "Diagnosis Procedure"](#).

16.CHECK SYMPTOM TABLE

Check items on the rough idle symptom in [EC-533, "Symptom Table"](#).

Is the inspection result normal?

YES >> GO TO 17.

NO >> Repair or replace malfunctioning part.

17.ERASE THE 1ST TRIP DTC

Some tests may cause a 1st trip DTC to be set.

Erase the 1st trip DTC from the ECM memory after performing the tests. Refer to [EC-102, "Diagnosis Description"](#).

>> GO TO 18.

18.CHECK INTERMITTENT INCIDENT

Refer to [GI-40, "Intermittent Incident"](#).

>> INSPECTION END

P0327, P0328, P0332, P0333 KS

Description

INFOID:000000003388034

The knock sensor is attached to the cylinder block. It senses engine knocking using a piezoelectric element. A knocking vibration from the cylinder block is sensed as vibrational pressure. This pressure is converted into a voltage signal and sent to the ECM.

DTC Logic

INFOID:000000003388035

DTC DETECTION LOGIC

DTC No.	Trouble diagnosis name	DTC detected condition	Possible cause
P0327	Knock sensor (bank 1) circuit low input	An excessively low voltage from the sensor is sent to ECM.	<ul style="list-style-type: none"> • Harness or connectors (The sensor circuit is open or shorted.) • Knock sensor
P0328	Knock sensor (bank 1) circuit high input	An excessively high voltage from the sensor is sent to ECM.	
P0332	Knock sensor (bank 2) circuit low input	An excessively low voltage from the sensor is sent to ECM.	
P0333	Knock sensor (bank 2) circuit high input	An excessively high voltage from the sensor is sent to ECM.	

DTC CONFIRMATION PROCEDURE

1. PRECONDITIONING

If DTC Confirmation Procedure has been previously conducted, always perform the following before conducting the next test.

1. Turn ignition switch OFF and wait at least 10 seconds.
2. Turn ignition switch ON.
3. Turn ignition switch OFF and wait at least 10 seconds.

TESTING CONDITION:

Before performing the following procedure, confirm that battery voltage is more than 10 V at idle.

>> GO TO 2.

2. PERFORM DTC CONFIRMATION PROCEDURE

1. Start engine and run it for at least 5 seconds at idle speed.
2. Check 1st trip DTC.

Is 1st trip DTC detected?

- YES >> Go to [EC-257, "Diagnosis Procedure"](#).
 NO >> INSPECTION END

Diagnosis Procedure

INFOID:000000003388036

1. CHECK GROUND CONNECTION

1. Turn ignition switch OFF.
2. Check ground connection E38. Refer to Ground Inspection in [GI-43, "Circuit Inspection"](#).

Is the inspection result normal?

- YES >> GO TO 2.
 NO >> Repair or replace ground connection.

2. CHECK KNOCK SENSOR GROUND CIRCUIT FOR OPEN AND SHORT

1. Disconnect knock sensor harness connector and ECM harness connector.
2. Check the continuity between knock sensor harness connector and ECM harness connector.

< COMPONENT DIAGNOSIS >

DTC	Knock sensor			ECM		Continuity
	Bank	Connector	Terminal	Connector	Terminal	
P0327, P0328	1	F201	2	F8	67	Existed
P0332, P0333	2	F202	2			

3. Also check harness for short to ground and short to power.

Is the inspection result normal?

- YES >> GO TO 4.
- NO >> GO TO 3.

3.DETECT MALFUNCTIONING PART

Check the following.

- Harness connectors F200, F78
- Harness for open or short between knock sensor and ECM

>> Repair open circuit, short to ground or short to power in harness or connectors.

4.CHECK KNOCK SENSOR INPUT SIGNAL CIRCUIT FOR OPEN AND SHORT

1. Check the continuity between knock sensor harness connector and ECM harness connector.

DTC	Knock sensor			ECM		Continuity
	Bank	Connector	Terminal	Connector	Terminal	
P0327, P0328	1	F201	1	F8	61	Existed
P0332, P0333	2	F202	1		62	

2. Also check harness for short to ground and short to power.

Is the inspection result normal?

- YES >> GO TO 6.
- NO >> GO TO 5.

5.DETECT MALFUNCTIONING PART

Check the following.

- Harness connectors F200, F78
- Harness for open or short between knock sensor and ECM

>> Repair open circuit, short to ground or short to power in harness or connectors.

6.CHECK KNOCK SENSOR

Refer to [EC-258, "Component Inspection"](#).

Is the inspection result normal?

- YES >> GO TO 7.
- NO >> Replace malfunctioning knock sensor.

7.CHECK INTERMITTENT INCIDENT

Refer to [GI-40, "Intermittent Incident"](#).

>> INSPECTION END

Component Inspection

INFOID:000000003388037

1.CHECK KNOCK SENSOR

1. Turn ignition switch OFF.
2. Disconnect knock sensor harness connector.
3. Check resistance between knock sensor terminal as per the following.

NOTE:

P0327, P0328, P0332, P0333 KS

< COMPONENT DIAGNOSIS >

[VQ35DE]

It is necessary to use an ohmmeter which can measure more than 10 MΩ.

Terminals	Resistance
1 and 2	Approx. 532 - 588 kΩ [at 20°C (68°F)]

CAUTION:

Never use any knock sensors that have been dropped or physically damaged. Use only new ones.

Is the inspection result normal?

- YES >> INSPECTION END
- NO >> Replace malfunctioning knock sensor.

A

EC

C

D

E

F

G

H

I

J

K

L

M

N

O

P

P0335 CKP SENSOR (POS)

< COMPONENT DIAGNOSIS >

[VQ35DE]

P0335 CKP SENSOR (POS)

Description

INFOID:000000003388038

The crankshaft position sensor (POS) is located on the oil pan facing the gear teeth (cogs) of the signal plate. It detects the fluctuation of the engine revolution.

The sensor consists of a permanent magnet and Hall IC.

When the engine is running, the high and low parts of the teeth cause the gap with the sensor to change.

The changing gap causes the magnetic field near the sensor to change.

Due to the changing magnetic field, the voltage from the sensor changes.

The ECM receives the voltage signal and detects the fluctuation of the engine revolution.

ECM receives the signals as shown in the figure.

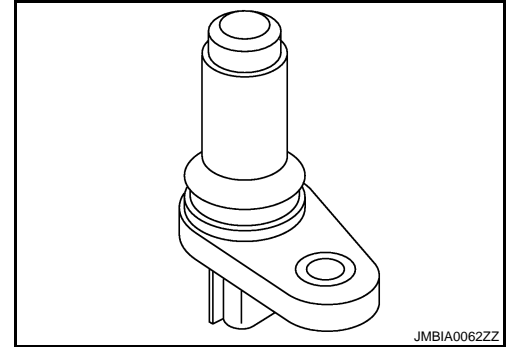

JMBIA0062ZZ

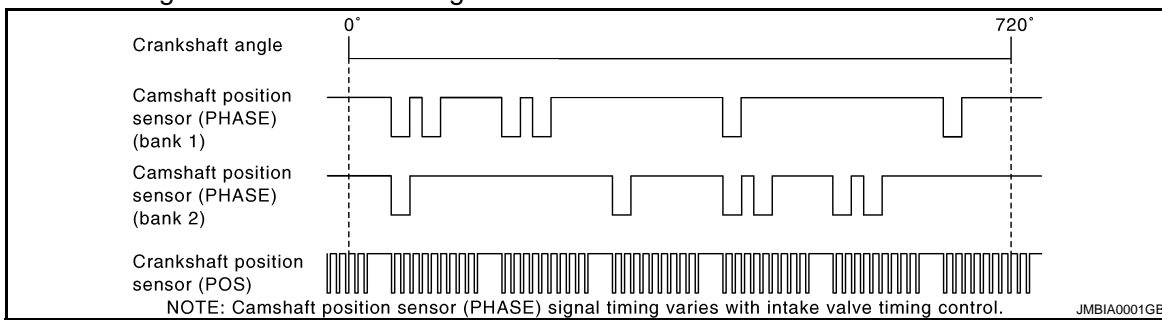

JMBIA0001GB

DTC Logic

INFOID:000000003388039

DTC DETECTION LOGIC

DTC No.	Trouble diagnosis name	DTC detecting condition	Possible cause
P0335	Crankshaft position sensor (POS) circuit	<ul style="list-style-type: none"> The crankshaft position sensor (POS) signal is not detected by the ECM during the first few seconds of engine cranking. The proper pulse signal from the crankshaft position sensor (POS) is not sent to ECM while the engine is running. The crankshaft position sensor (POS) signal is not in the normal pattern during engine running. 	<ul style="list-style-type: none"> Harness or connectors [CKP sensor (POS) circuit is open or shorted.] (APP sensor 2 circuit is shorted.) (EVAP control system pressure sensor circuit is shorted.) (Refrigerant pressure sensor circuit is shorted.) Crankshaft position sensor (POS) Accelerator pedal position sensor EVAP control system pressure sensor Refrigerant pressure sensor Signal plate

DTC CONFIRMATION PROCEDURE

1. PRECONDITIONING

If DTC Confirmation Procedure has been previously conducted, always perform the following before conducting the next test.

- Turn ignition switch OFF and wait at least 10 seconds.
- Turn ignition switch ON.
- Turn ignition switch OFF and wait at least 10 seconds.

TESTING CONDITION:

Before performing the following procedure, confirm that battery voltage is more than 10.5 V with ignition switch ON.

>> GO TO 2.

P0335 CKP SENSOR (POS)

[VQ35DE]

< COMPONENT DIAGNOSIS >

2. PERFORM DTC CONFIRMATION PROCEDURE

1. Start engine and let it idle for at least 5 seconds.
If engine does not start, crank engine for at least 2 seconds.
2. Check 1st trip DTC.

Is 1st trip DTC detected?

- YES >> Go to [EC-261, "Diagnosis Procedure"](#).
NO >> INSPECTION END

Diagnosis Procedure

INFOID:000000003388040

1. CHECK GROUND CONNECTION

1. Turn ignition switch OFF.
2. Check ground connection E38. Refer to Ground Inspection in [GI-43, "Circuit Inspection"](#).

Is the inspection result normal?

- YES >> GO TO 2.
NO >> Repair or replace ground connection.

2. CHECK CRANKSHAFT POSITION (CKP) SENSOR (POS) POWER SUPPLY CIRCUIT-I

1. Disconnect crankshaft position (CKP) sensor (POS) harness connector.
2. Turn ignition switch ON.
3. Check the voltage between CKP sensor (POS) harness connector and ground.

CKP sensor (POS)		Ground	Voltage (V)
Connector	Terminal		
F20	1	Ground	Approx. 5

Is the inspection result normal?

- YES >> GO TO 8.
NO >> GO TO 3.

3. CHECK CRANKSHAFT POSITION (CKP) SENSOR (POS) POWER SUPPLY CIRCUIT-II

1. Turn ignition switch ON.
2. Disconnect ECM harness connector.
3. Check the continuity between CKP sensor (POS) harness connector and ECM harness connector.

CKP sensor (POS)		ECM		Continuity
Connector	Terminal	Connector	Terminal	
F20	1	F8	76	Existed

Is the inspection result normal?

- YES >> GO TO 4.
NO >> Repair open circuit.

4. CHECK SENSOR POWER SUPPLY CIRCUIT

Check harness for short to power and short to ground, between the following terminals.

ECM		Sensor		
Connector	Terminal	Name	Connector	Terminal
F8	72	Refrigerant pressure sensor	E300	1
	76	CKP sensor (POS)	F20	1
E16	87	APP sensor	E110	5
	91	EVAP control system pressure sensor	B17	3

Is the inspection result normal?

- YES >> GO TO 5.

P0335 CKP SENSOR (POS)

[VQ35DE]

< COMPONENT DIAGNOSIS >

NO >> Repair short to ground or short to power in harness or connectors.

5.CHECK COMPONENTS

Check the following.

- EVAP control system pressure sensor (Refer to [EC-302, "Component Inspection"](#).)
- Refrigerant pressure sensor (Refer to [EC-463, "Diagnosis Procedure"](#).)

Is the inspection result normal?

YES >> GO TO 6.

NO >> Replace malfunctioning components.

6.CHECK APP SENSOR

Refer to [EC-415, "Component Inspection"](#).

Is the inspection result normal?

YES >> GO TO 12.

NO >> GO TO 7.

7.REPLACE ACCELERATOR PEDAL ASSEMBLY

1. Replace accelerator pedal assembly.
2. Refer to [EC-415, "Special Repair Requirement"](#).

>> INSPECTION END

8.CHECK CKP SENSOR (POS) GROUND CIRCUIT FOR OPEN AND SHORT

1. Turn ignition switch OFF.
2. Disconnect ECM harness connector.
3. Check the continuity between CKP sensor (POS) harness connector and ECM harness connector.

CKP sensor (POS)		ECM		Continuity
Connector	Terminal	Connector	Terminal	
F20	2	F8	60	Existed

4. Also check harness for short to ground and short to power.

Is the inspection result normal?

YES >> GO TO 9.

NO >> Repair open circuit, short to ground or short to power in harness or connectors.

9.CHECK CKP SENSOR (POS) INPUT SIGNAL CIRCUIT FOR OPEN AND SHORT

1. Check the continuity between CKP sensor (POS) harness connector and ECM harness connector.

CKP sensor (POS)		ECM		Continuity
Connector	Terminal	Connector	Terminal	
F20	3	F8	65	Existed

2. Also check harness for short to ground and short to power.

Is the inspection result normal?

YES >> GO TO 10.

NO >> Repair open circuit, short to ground or short to power in harness or connectors.

10.CHECK CRANKSHAFT POSITION SENSOR (POS)

Refer to [EC-263, "Component Inspection"](#).

Is the inspection result normal?

YES >> GO TO 11.

NO >> Replace crankshaft position sensor (POS).

11.CHECK GEAR TOOTH

Visually check for chipping signal plate gear tooth.

Is the inspection result normal?

P0335 CKP SENSOR (POS)

[VQ35DE]

< COMPONENT DIAGNOSIS >

- YES >> GO TO 12.
- NO >> Replace the signal plate.

12.CHECK INTERMITTENT INCIDENT

Refer to [GI-40. "Intermittent Incident"](#).

>> INSPECTION END

Component Inspection

INFOID:000000003388041

1.CHECK CRANKSHAFT POSITION SENSOR (POS)-I

1. Loosen the fixing bolt of the sensor.
2. Disconnect crankshaft position sensor (POS) harness connector.
3. Remove the sensor.
4. Visually check the sensor for chipping.

Is the inspection result normal?

- YES >> GO TO 2.
- NO >> Replace crankshaft position sensor (POS)

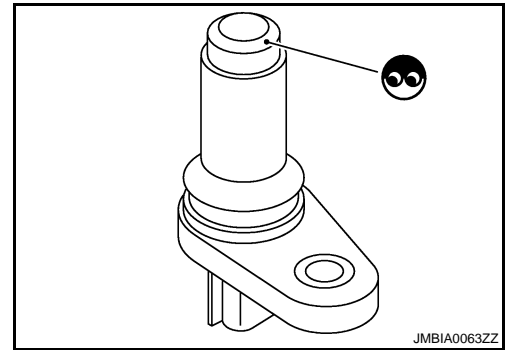

2.CHECK CRANKSHAFT POSITION SENSOR (POS)-II

Check resistance crankshaft position sensor (POS) terminals as per the following.

Terminal No. (Polarity)	Resistance
1 (+) - 2 (-)	Except 0 or ∞ Ω [at 25°C (77°F)]
1 (+) - 3 (-)	
2 (+) - 3 (-)	

Is the inspection result normal?

- YES >> INSPECTION END
- NO >> Replace crankshaft position sensor (POS)

P0340, P0345 CMP SENSOR (PHASE)

< COMPONENT DIAGNOSIS >

[VQ35DE]

P0340, P0345 CMP SENSOR (PHASE)

Description

INFOID:000000003388042

The camshaft position sensor (PHASE) senses the protrusion of camshaft (INT) to identify a particular cylinder. The camshaft position sensor (PHASE) senses the piston position.

When the crankshaft position sensor (POS) system becomes inoperative, the camshaft position sensor (PHASE) provides various controls of engine parts instead, utilizing timing of cylinder identification signals.

The sensor consists of a permanent magnet and Hall IC.

When engine is running, the high and low parts of the teeth cause the gap with the sensor to change.

The changing gap causes the magnetic field near the sensor to change.

Due to the changing magnetic field, the voltage from the sensor changes. ECM receives the signals as shown in the figure.

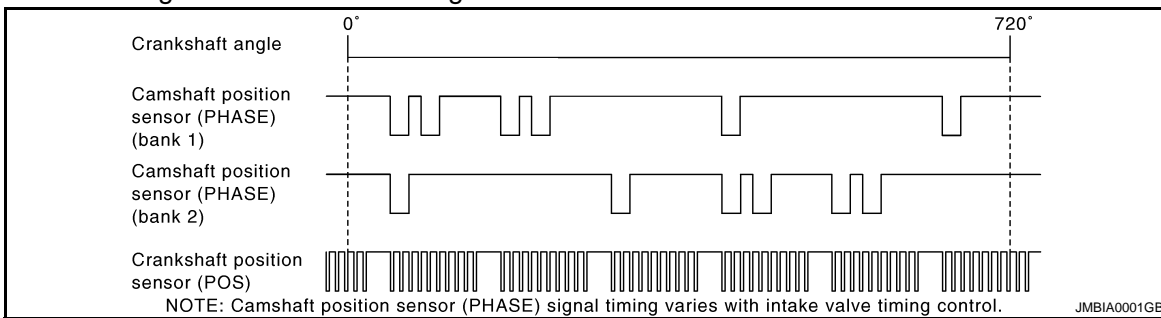
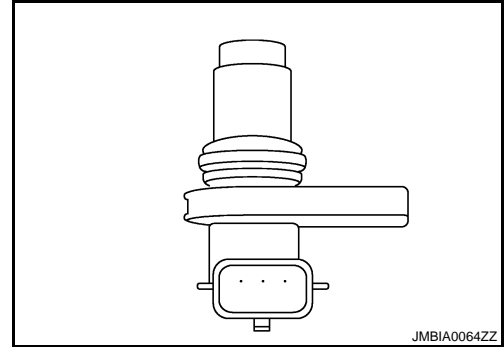

DTC Logic

INFOID:000000003388043

DTC DETECTION LOGIC

NOTE:

If DTC P0340 or P0345 is displayed with DTC P0643, first perform the trouble diagnosis for DTC P0643. Refer to [EC-347, "DTC Logic"](#).

DTC No.	Trouble diagnosis name	DTC detecting condition	Possible cause
P0340	Camshaft position sensor (PHASE) (bank 1) circuit	<ul style="list-style-type: none"> The cylinder No. signal is not sent to ECM for the first few seconds during engine cranking. The cylinder No. signal is not sent to ECM during engine running. 	<ul style="list-style-type: none"> Harness or connectors (The sensor circuit is open or shorted) Camshaft position sensor (PHASE) Camshaft (INT)
P0345	Camshaft position sensor (PHASE) (bank 2) circuit	<ul style="list-style-type: none"> The cylinder No. signal is not in the normal pattern during engine running. 	<ul style="list-style-type: none"> Starter motor (Refer to STR-5.) Starting system circuit (Refer to STR-5.) Dead (Weak) battery

DTC CONFIRMATION PROCEDURE

1. PRECONDITIONING

If DTC Confirmation Procedure has been previously conducted, always perform the following before conducting the next test.

- Turn ignition switch OFF and wait at least 10 seconds.
- Turn ignition switch ON.
- Turn ignition switch OFF and wait at least 10 seconds.

TESTING CONDITION:

Before performing the following procedure, confirm that battery voltage is more than 10.5 V with ignition switch ON.

>> GO TO 2.

2. PERFORM DTC CONFIRMATION PROCEDURE-I

P0340, P0345 CMP SENSOR (PHASE)

[VQ35DE]

< COMPONENT DIAGNOSIS >

1. Start engine and let it idle for at least 5 seconds.
If engine does not start, crank engine for at least 2 seconds.
2. Check 1st trip DTC.

Is 1st trip DTC detected?

- YES >> Go to [EC-265, "Diagnosis Procedure"](#).
NO >> GO TO 3.

3.PERFORM DTC CONFIRMATION PROCEDURE-I

1. Maintaining engine speed at more than 800 rpm for at least 5 seconds.
2. Check 1st trip DTC.

Is 1st trip DTC detected?

- YES >> Go to [EC-265, "Diagnosis Procedure"](#).
NO >> INSPECTION END

Diagnosis Procedure

INFOID:000000003388044

1.CHECK STARTING SYSTEM

Turn ignition switch to START position.

Does the engine turn over? Does the starter motor operate?

- YES >> GO TO 2.
NO >> Check starting system. (Refer to [STR-2, "Work Flow"](#).)

2.CHECK GROUND CONNECTION

1. Turn ignition switch OFF.
2. Check ground connection E38. Refer to Ground Inspection in [GI-43, "Circuit Inspection"](#).

Is the inspection result normal?

- YES >> GO TO 3.
NO >> Repair or replace ground connection.

3.CHECK CAMSHAFT POSITION (CMP) SENSOR (PHASE) POWER SUPPLY CIRCUIT

1. Disconnect camshaft position (CMP) sensor (PHASE) harness connector.
2. Turn ignition switch ON.
3. Check the voltage between CMP sensor (PHASE) harness connector and ground.

DTC	CMP sensor (PHASE)			Ground	Voltage (V)
	Bank	Connector	Terminal		
P0340	1	F26	1	Ground	Approx. 5
P0345	2	F69	1		

Is the inspection result normal?

- YES >> GO TO 4.
NO >> Repair open circuit, short to ground or short to power in harness or connectors.

4.CHECK CMP SENSOR (PHASE) GROUND CIRCUIT FOR OPEN AND SHORT

1. Turn ignition switch OFF.
2. Disconnect ECM harness connector.
3. Check the continuity between CMP sensor (PHASE) harness connector and ECM harness connector.

DTC	CMP sensor (PHASE)			ECM		Continuity
	Bank	Connector	Terminal	Connector	Terminal	
P0340	1	F26	2	F8	64	Existed
P0345	2	F69	2		68	

4. Also check harness for short to ground and short to power.

Is the inspection result normal?

- YES >> GO TO 5.

P0340, P0345 CMP SENSOR (PHASE)

[VQ35DE]

< COMPONENT DIAGNOSIS >

NO >> Repair open circuit, short to ground or short to power in harness or connectors.

5. CHECK CMP SENSOR (PHASE) INPUT SIGNAL CIRCUIT FOR OPEN AND SHORT

1. Check the continuity between CMP sensor (PHASE) harness connector and ECM harness connector.

DTC	CMP sensor (PHASE)			ECM		Continuity
	Bank	Connector	Terminal	Connector	Terminal	
P0340	1	F26	3	F8	70	Existed
P0345	2	F69	3		69	

2. Also check harness for short to ground and short to power.

Is the inspection result normal?

YES >> GO TO 6.

NO >> Repair open circuit, short to ground or short to power in harness or connectors.

6. CHECK CAMSHAFT POSITION SENSOR (PHASE)

Refer to [EC-266, "Component Inspection"](#).

Is the inspection result normal?

YES >> GO TO 7.

NO >> Replace malfunctioning camshaft position sensor (PHASE).

7. CHECK CAMSHAFT (INT)

Check the following.

- Accumulation of debris to the signal plate of camshaft rear end
- Chipping signal plate of camshaft rear end

Is the inspection result normal?

YES >> GO TO 8.

NO >> Remove debris and clean the signal plate of camshaft rear end or replace camshaft.

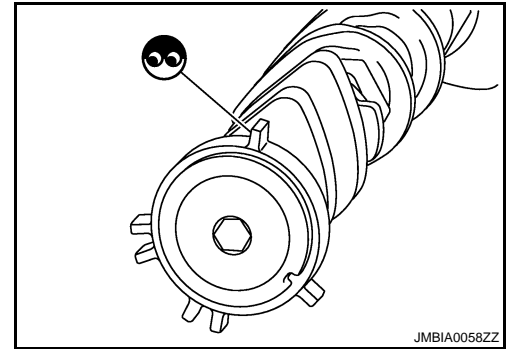

8. CHECK INTERMITTENT INCIDENT

Refer to [GI-40, "Intermittent Incident"](#).

>> INSPECTION END

Component Inspection

INFOID:000000003388045

1. CHECK CAMSHAFT POSITION SENSOR (PHASE)-I

1. Turn ignition switch OFF.
2. Loosen the fixing bolt of the sensor.
3. Disconnect camshaft position sensor (PHASE) harness connector.
4. Remove the sensor.
5. Visually check the sensor for chipping.

Is the inspection result normal?

YES >> GO TO 2.

NO >> Replace malfunctioning camshaft position sensor (PHASE).

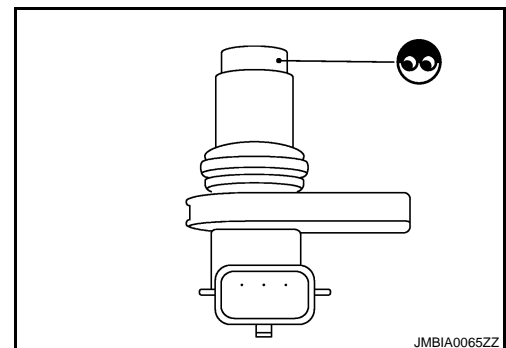

P0340, P0345 CMP SENSOR (PHASE)

< COMPONENT DIAGNOSIS >

[VQ35DE]

2. CHECK CAMSHAFT POSITION SENSOR (PHASE)-II

Check resistance camshaft position sensor (PHASE) terminals as per the following.

Terminal No. (Polarity)	Resistance
1 (+) - 2 (-)	Except 0 or ∞ Ω [at 25°C (77°F)]
1 (+) - 3 (-)	
2 (+) - 3 (-)	

Is the inspection result normal?

YES >> INSPECTION END

NO >> Replace malfunctioning camshaft position sensor (PHASE).

A

EC

C

D

E

F

G

H

I

J

K

L

M

N

O

P

P0420, P0430 THREE WAY CATALYST FUNCTION

< COMPONENT DIAGNOSIS >

[VQ35DE]

P0420, P0430 THREE WAY CATALYST FUNCTION

DTC Logic

INFOID:000000003388046

DTC DETECTION LOGIC

The ECM monitors the switching frequency ratio of air fuel ratio (A/F) sensor 1 and heated oxygen sensor 2.

A three way catalyst (manifold) with high oxygen storage capacity will indicate a low switching frequency of heated oxygen sensor 2. As oxygen storage capacity decreases, the heated oxygen sensor 2 switching frequency will increase.

When the frequency ratio of A/F sensor 1 and heated oxygen sensor 2 approaches a specified limit value, the three way catalyst (manifold) malfunction is diagnosed.

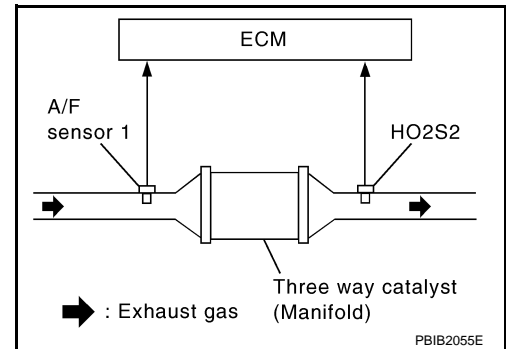

DTC No.	Trouble diagnosis name	DTC detecting condition	Possible cause
P0420	Catalyst system efficiency below threshold (bank 1)	<ul style="list-style-type: none"> • Three way catalyst (manifold) does not operate properly. • Three way catalyst (manifold) does not have enough oxygen storage capacity. 	<ul style="list-style-type: none"> • Three way catalyst (manifold) • Exhaust tube • Intake air leakage • Fuel injector • Fuel injector leakage • Spark plug • Improper ignition timing
P0430	Catalyst system efficiency below threshold (bank 2)		

DTC CONFIRMATION PROCEDURE

1.INSPECTION START

Will CONSULT-III be used?

Will CONSULT-III be used?

YES >> GO TO 2.

NO >> GO TO 7.

2.PRECONDITIONING

If DTC Confirmation Procedure has been previously conducted, always perform the following before conducting the next test.

1. Turn ignition switch OFF and wait at least 10 seconds.
2. Turn ignition switch ON.
3. Turn ignition switch OFF and wait at least 10 seconds.

TESTING CONDITION:

Do not maintain engine speed for more than the specified minutes below.

>> GO TO 3.

3.PERFORM DTC CONFIRMATION PROCEDURE-I

Ⓜ With CONSULT-III

1. Turn ignition switch ON and select "DATA MONITOR" mode with CONSULT-III.
2. Start engine and warm it up to the normal operating temperature.
3. Turn ignition switch OFF and wait at least 10 seconds.
4. Turn ignition switch ON.
5. Turn ignition switch OFF and wait at least 10 seconds.
6. Start engine and keep the engine speed between 3,500 and 4,000 rpm for at least 1 minute under no load.
7. Let engine idle for 1 minute.
8. Check that "COOLAN TEMP/S" indicates more than 70°C (158°F).
If not, warm up engine and go to next step when "COOLAN TEMP/S" indication reaches 70°C (158°F).
9. Open engine hood.
10. Select "DTC & SRT CONFIRMATION" then "SRT WORK SUPPORT" mode with CONSULT-III.

P0420, P0430 THREE WAY CATALYST FUNCTION

[VQ35DE]

< COMPONENT DIAGNOSIS >

11. Rev engine between 2,000 and 3,000 rpm and hold it for 3 consecutive minutes then release the accelerator pedal completely.
12. Check the indication of "CATALYST".

Which is displayed on CONSULT-III screen?

- CMPLT >> GO TO 6.
- INCMP >> GO TO 4.

4.PERFORM DTC CONFIRMATION PROCEDURE-II

1. Wait 5 seconds at idle.
2. Rev engine between 2,000 and 3,000 rpm and maintain it until "INCMP" of "CATALYST" changes to "CMPLT" (It will take approximately 5 minutes).

Does the indication change to "CMPLT"?

- YES >> GO TO 6.
- NO >> GO TO 5.

5.PERFORM DTC CONFIRMATION PROCEDURE AGAIN

1. Stop engine and cool it down to less than 70°C (158°F).
2. Perform DTC CONFIRMATION PROCEDURE again.

>> GO TO 3.

6.PERFORM DTC CONFIRMATION PROCEDURE-III

Check 1st trip DTC.

Is 1st trip DTC detected?

- YES >> Go to [EC-270, "Diagnosis Procedure"](#).
- NO >> INSPECTION END

7.PERFORM COMPONENT FUNCTION CHECK

Perform component function check. Refer to [EC-269, "Component Function Check"](#).

NOTE:

Use component function check to check the overall function of the three way catalyst (manifold). During this check, a 1st trip DTC might not be confirmed.

Is the inspection result normal?

- YES >> INSPECTION END
- NO >> Go to [EC-270, "Diagnosis Procedure"](#).

Component Function Check

INFOID:000000003388047

1.PERFORM COMPONENT FUNCTION CHECK

Without CONSULT-III

1. Start engine and warm it up to the normal operating temperature.
2. Turn ignition switch OFF and wait at least 10 seconds.
3. Turn ignition switch ON.
4. Turn ignition switch OFF and wait at least 10 seconds.
5. Start engine and keep the engine speed between 3,500 and 4,000 rpm for at least 1 minute under no load.
6. Let engine idle for 1 minute.
7. Open engine hood.
8. Check the voltage between ECM harness connector terminals under the following conditions.

P0420, P0430 THREE WAY CATALYST FUNCTION

< COMPONENT DIAGNOSIS >

[VQ35DE]

DTC	ECM			Condition	Voltage (V)
	Conne- ctor	+	-		
		Terminal	Terminal		
P0420	F8	33 [HO2S2 (bank 1) signal]	35 (Sensor ground)	Keeping engine speed at 2,500 rpm constant under no load	The voltage fluctuation cycle takes more than 5 seconds. • 1 cycle: 0.6 - 1.0 → 0 - 0.3 → 0.6 - 1.0
P0430		34 [HO2S2 (bank 2) signal]			

Is the inspection result normal?

YES >> INSPECTION END

NO >> Go to [EC-270. "Diagnosis Procedure"](#).

Diagnosis Procedure

INFOID:000000003388048

1. CHECK EXHAUST SYSTEM

Visually check exhaust tubes and muffler for dents.

Is the inspection result normal?

YES >> GO TO 2.

NO >> Repair or replace malfunctioning part.

2. CHECK EXHAUST GAS LEAKAGE

1. Start engine and run it at idle.

2. Listen for an exhaust gas leakage before the three way catalyst (manifold).

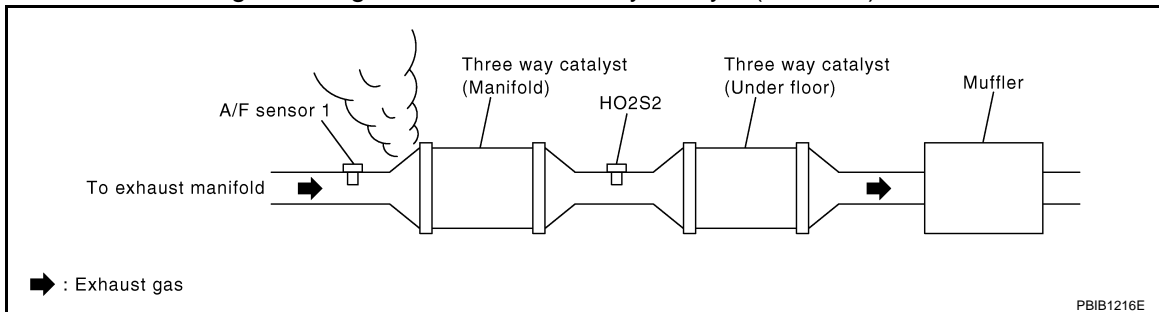

Is exhaust gas leakage detected?

YES >> Repair or replace malfunctioning part.

NO >> GO TO 3.

3. CHECK INTAKE AIR LEAKAGE

Listen for an intake air leakage after the mass air flow sensor.

Is intake air leakage detected?

YES >> Repair or replace malfunctioning part.

NO >> GO TO 4.

4. CHECK IGNITION TIMING

Check idle speed and ignition timing.

For procedure, refer to [EC-12. "BASIC INSPECTION : Special Repair Requirement"](#).

For specification, refer to [EC-551. "Idle Speed"](#) and [EC-551. "Ignition Timing"](#).

Is the inspection result normal?

YES >> GO TO 5.

NO >> Follow the [EC-12. "BASIC INSPECTION : Special Repair Requirement"](#).

5. CHECK FUEL INJECTORS

1. Stop engine and then turn ignition switch ON.

2. Check the voltage between ECM harness connector terminals.

P0420, P0430 THREE WAY CATALYST FUNCTION

< COMPONENT DIAGNOSIS >

[VQ35DE]

ECM				Voltage
+		-		
Connector	Terminal	Connector	Terminal	
F7	1	E16	112	Battery voltage
	3			
	29			
	30			
	31			
	32			

Is the inspection result normal?

YES >> GO TO 6.

NO >> Perform [EC-444, "Diagnosis Procedure"](#).

6. CHECK FUNCTION OF IGNITION COIL-I

CAUTION:

Perform the following procedure in a place with no combustible objects and good ventilation.

1. Turn ignition switch OFF.
2. Remove fuel pump fuse in IPDM E/R to release fuel pressure.

NOTE:

Do not use CONSULT-III to release fuel pressure, or fuel pressure applies again during the following procedure.

3. Start engine.
4. After engine stalls, crank it 2 or 3 times to release all fuel pressure.
5. Turn ignition switch OFF.
6. Remove all ignition coil harness connectors to avoid the electrical discharge from the ignition coils.
7. Remove ignition coil and spark plug of the cylinder to be checked.
8. Crank engine for 5 seconds or more to remove combustion gas in the cylinder.
9. Connect spark plug and harness connector to ignition coil.
10. Fix ignition coil using a rope etc. with gap of 13 - 17 mm (0.52 - 0.66 in) between the edge of the spark plug and grounded metal portion as shown in the figure.
11. Crank engine for approximately 3 seconds, and check whether spark is generated between the spark plug and the grounded metal portion.

Spark should be generated.

CAUTION:

- During the operation, always stay 0.5 m (19.7 in) or more away from the spark plug and the ignition coil. Be careful not to get an electrical shock while checking, because the electrical discharge voltage becomes 20 kV or more.
- It might cause to damage the ignition coil if the gap of more than 17 mm (0.66 in) is taken.

NOTE:

When the gap is less than 13 mm (0.52 in), the spark might be generated even if the coil is malfunctioning.

Is the inspection result normal?

YES >> GO TO 10.

NO >> GO TO 7.

7. CHECK FUNCTION OF IGNITION COIL-II

1. Turn ignition switch OFF.
2. Disconnect spark plug and connect a known-good spark plug.
3. Crank engine for approximately 3 seconds, and recheck whether spark is generated between the spark plug and the grounded metal portion.

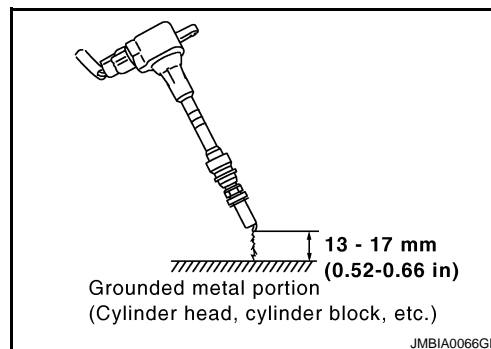

Spark should be generated.

Is the inspection result normal?

YES >> GO TO 8.

NO >> Check ignition coil, power transistor and their circuit. Refer to [EC-451. "Diagnosis Procedure"](#).

8. CHECK SPARK PLUG

Check the initial spark plug for fouling, etc.

Is the inspection result normal?

YES >> Replace spark plug(s) with standard type one(s). For spark plug type, refer to [EM-142. "Spark Plug"](#).

NO >> Repair or clean spark plug. Then GO TO 9.

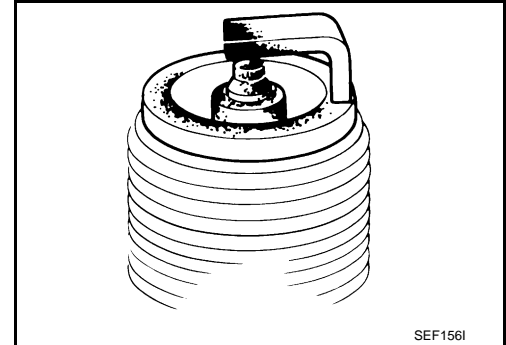

9. CHECK FUNCTION OF IGNITION COIL-III

1. Reconnect the initial spark plugs.
2. Crank engine for approximately 3 seconds, and recheck whether spark is generated between the spark plug and the grounded portion.

Spark should be generated.

Is the inspection result normal?

YES >> INSPECTION END

NO >> Replace spark plug(s) with standard type one(s). For spark plug type, refer to [EM-142. "Spark Plug"](#).

10. CHECK FUEL INJECTOR

1. Turn ignition switch OFF.
2. Remove fuel injector assembly.
Refer to [EM-45. "Removal and Installation"](#).
Keep fuel hose and all fuel injectors connected to fuel tube.
3. Disconnect all ignition coil harness connectors.
4. Reconnect all fuel injector harness connectors disconnected.
5. Turn ignition switch ON.
6. Check that the fuel does not drip from fuel injector.

Does fuel drip from fuel injector?

YES >> Replace the fuel injector(s) from which fuel is dripping.

NO >> GO TO 11.

11. CHECK INTERMITTENT INCIDENT

Refer to [GI-40. "Intermittent Incident"](#).

Is the inspection result normal?

YES >> Replace three way catalyst assembly.

NO >> Repair or replace harness or connector.

P0441 EVAP CONTROL SYSTEM

< COMPONENT DIAGNOSIS >

[VQ35DE]

P0441 EVAP CONTROL SYSTEM

DTC Logic

INFOID:000000003388049

DTC DETECTION LOGIC

NOTE:

If DTC P0441 is displayed with other DTC such as P2122, P2123, P2127, P2128 or P2138, first perform trouble diagnosis for other DTC.

In this evaporative emission (EVAP) control system, purge flow occurs during non-closed throttle conditions. Purge volume is related to air intake volume. Under normal purge conditions (non-closed throttle), the EVAP canister purge volume control solenoid valve is open to admit purge flow. Purge flow exposes the EVAP control system pressure sensor to intake manifold vacuum.

Under normal conditions (non-closed throttle), sensor output voltage indicates if pressure drop and purge flow are adequate. If not, a malfunction is determined.

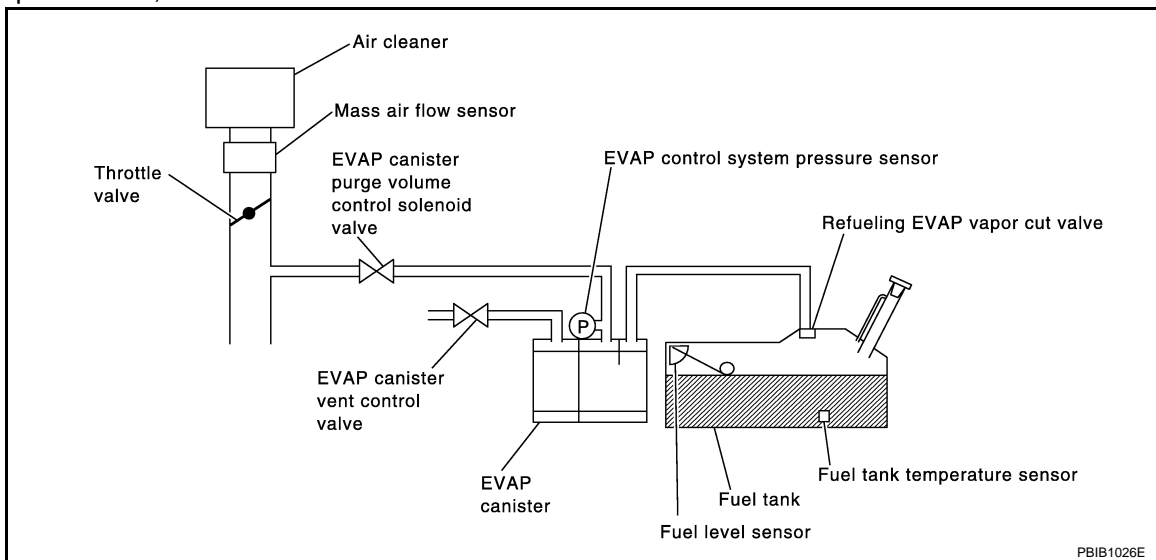

DTC No.	Trouble diagnosis name	DTC detecting condition	Possible cause
P0441	EVAP control system incorrect purge flow	EVAP control system does not operate properly, EVAP control system has a leakage between intake manifold and EVAP control system pressure sensor.	<ul style="list-style-type: none"> • EVAP canister purge volume control solenoid valve stuck closed • EVAP control system pressure sensor and the circuit • Loose, disconnected or improper connection of rubber tube • Blocked rubber tube • Cracked EVAP canister • EVAP canister purge volume control solenoid valve circuit • Accelerator pedal position sensor • Blocked purge port • EVAP canister vent control valve

DTC CONFIRMATION PROCEDURE

1.INSPECTION START

Will CONSULT-III be used?

Will CONSULT-III be used?

YES >> GO TO 2.

NO >> GO TO 6.

2.PRECONDITIONING

If DTC Confirmation Procedure has been previously conducted, always perform the following before conducting the next test.

1. Turn ignition switch OFF and wait at least 10 seconds.

P0441 EVAP CONTROL SYSTEM

[VQ35DE]

< COMPONENT DIAGNOSIS >

2. Turn ignition switch ON.
3. Turn ignition switch OFF and wait at least 10 seconds.

TESTING CONDITION:

Always perform test at a temperature of 5°C (41°F) or more.

>> GO TO 3.

3.PERFORM DTC CONFIRMATION PROCEDURE-I

With CONSULT-III

1. Start engine and warm it up to normal operating temperature.
2. Turn ignition switch OFF and wait at least 10 seconds.
3. Turn ignition switch ON.
4. Turn ignition switch OFF and wait at least 10 seconds.
5. Start engine and let it idle for at least 70 seconds.
6. Select "PURG FLOW P0441" of "EVAPORATIVE SYSTEM" in "DTC WORK SUPPORT" mode with CONSULT-III.
7. Touch "START".

Is "COMPLETED" displayed on CONSULT-III screen?

- YES >> GO TO 5.
NO >> GO TO 4.

4.PERFORM DTC CONFIRMATION PROCEDURE-II

When the following conditions are met, "TESTING" will be displayed on the CONSULT-III screen. Maintain the conditions continuously until "TESTING" changes to "COMPLETED". (It will take at least 35 seconds.)

Selector lever	Suitable position
VHCL SPEED SE	32 - 120 km/h (20 - 75 mph)
ENG SPEED	500 - 3,000 rpm
B/FUEL SCHDL	1.3 - 9.0 msec
COOLAN TEMP/S	More than 0°C (32°F)

CAUTION:

Always drive vehicle at a safe speed.

If "TESTING" does not change for a long time, retry from step 2.

Is "COMPLETED" displayed on CONSULT-III screen?

- YES >> GO TO 5.
NO >> Perform DTC CONFIRMATION PROCEDURE again. GO TO 3.

5.PERFORM DTC CONFIRMATION PROCEDURE-III

Touch "SELF-DIAG RESULTS".

Which is displayed on CONSULT-III screen?

- OK >> INSPECTION END
NG >> Go to [EC-275, "Diagnosis Procedure"](#).

6.PERFORM COMPONENT FUNCTION CHECK

Perform component function check. Refer to [EC-274, "Component Function Check"](#).

NOTE:

Use component function check to check the overall monitoring function of the EVAP control system purge flow monitoring. During this check, a 1st trip DTC might not be confirmed.

Is the inspection result normal?

- YES >> INSPECTION END
NO >> Go to [EC-275, "Diagnosis Procedure"](#).

Component Function Check

INFOID:000000003388050

1.PERFORM COMPONENT FUNCTION CHECK

Without CONSULT-III

P0441 EVAP CONTROL SYSTEM

[VQ35DE]

< COMPONENT DIAGNOSIS >

1. Lift up drive wheels.
2. Start engine (VDC switch OFF) and warm it up to normal operating temperature.
3. Turn ignition switch OFF, wait at least 10 seconds.
4. Turn ignition switch ON.
5. Turn ignition switch OFF, wait at least 10 seconds.
6. Start engine and wait at least 70 seconds.
7. Set voltmeter probes to ECM harness connector terminals under the following conditions.

ECM		
Connector	+	-
	Terminal	Terminal
E16	86 (EVAP control system pressure sensor signal)	96 (Sensor ground)

8. Check EVAP control system pressure sensor value at idle speed and note it.
9. Establish and maintain the following conditions for at least 1 minute.

Air conditioner switch	ON
Head lamp switch	ON
Rear window defogger switch	ON
Engine speed	Approx. 3,000 rpm
Gear position	Any position other than P, N or R

10. Verify that EVAP control system pressure sensor value stays 0.1 V less than the value at idle speed (measured at step 6) for at least 1 second.

Is the inspection result normal?

- YES >> INSPECTION END
 NO >> Go to [EC-275. "Diagnosis Procedure"](#).

Diagnosis Procedure

INFOID:000000003388051

1. CHECK EVAP CANISTER

1. Turn ignition switch OFF.
2. Check EVAP canister for cracks.

Is the inspection result normal?

- YES-1 >> With CONSULT-III: GO TO 2.
 YES-2 >> Without CONSULT-III: GO TO 3.
 NO >> Replace EVAP canister.

2. CHECK PURGE FLOW

With CONSULT-III

1. Disconnect vacuum hose connected to EVAP canister purge volume control solenoid valve at EVAP service port and install vacuum gauge. For the location of EVAP service port, refer to [EC-77. "System Diagram"](#).
2. Start engine and let it idle.
3. Select "PURG VOL C/V" in "ACTIVE TEST" mode with CONSULT-III.
4. Touch "Qd" and "Qu" on CONSULT-III screen to adjust "PURG VOL C/V" opening and check vacuum existence.

PURG VOL C/V	Vacuum
100%	Existed
0%	Not existed

Is the inspection result normal?

- YES >> GO TO 7.
 NO >> GO TO 4.

P0441 EVAP CONTROL SYSTEM

< COMPONENT DIAGNOSIS >

[VQ35DE]

3. CHECK PURGE FLOW

⊗ Without CONSULT-III

1. Start engine and warm it up to normal operating temperature.
2. Stop engine.
3. Disconnect vacuum hose connected to EVAP canister purge volume control solenoid valve at EVAP service port and install vacuum gauge. For the location of EVAP service port, refer to [EC-77. "System Diagram"](#).
4. Start engine and let it idle.
Do not depress accelerator pedal even slightly.
5. Check vacuum gauge indication before 60 seconds pass after starting engine.

Vacuum should not exist.

6. Rev engine up to 2,000 rpm after 100 seconds pass after starting engine.

Vacuum should exist.

Is the inspection result normal?

- YES >> GO TO 7.
NO >> GO TO 4.

4. CHECK EVAP PURGE LINE

1. Turn ignition switch OFF.
2. Check EVAP purge line for improper connection or disconnection.
Refer to [EC-77. "System Diagram"](#).

Is the inspection result normal?

- YES >> GO TO 5.
NO >> Repair EVAP purge line.

5. CHECK EVAP PURGE HOSE AND PURGE PORT

1. Disconnect purge hoses connected to EVAP service port **A** and EVAP canister purge volume control solenoid valve **B**.
2. Blow air into each hose and EVAP purge port **C**.

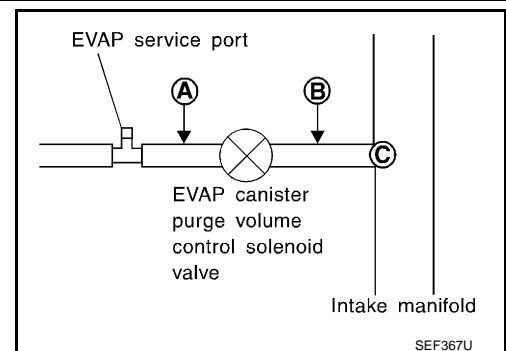

3. Check that air flows freely.

Is the inspection result normal?

- YES-1 >> With CONSULT-III: GO TO 6.
YES-2 >> Without CONSULT-III: GO TO 7.
NO >> Repair or clean hoses and/or purge port.

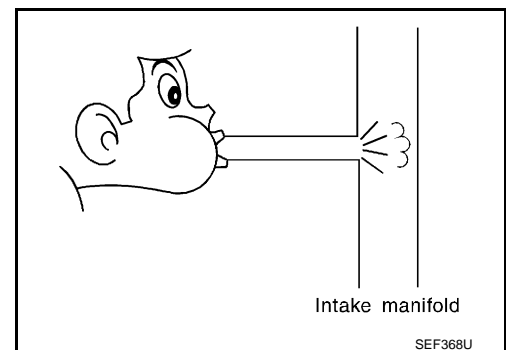

6. CHECK EVAP CANISTER PURGE VOLUME CONTROL SOLENOID VALVE

Ⓟ With CONSULT-III

1. Start engine.
2. Perform "PURG VOL C/V" in "ACTIVE TEST" mode with CONSULT-III. Check that engine speed varies according to the valve opening.

P0441 EVAP CONTROL SYSTEM

[VQ35DE]

< COMPONENT DIAGNOSIS >

Does engine speed vary according to the valve opening?

- YES >> GO TO 8.
NO >> GO TO 7.

A

7.CHECK EVAP CANISTER PURGE VOLUME CONTROL SOLENOID VALVE

Refer to [EC-287, "Component Inspection"](#).

Is the inspection result normal?

- YES >> GO TO 8.
NO >> Replace EVAP canister purge volume control solenoid valve.

C

8.CHECK EVAP CONTROL SYSTEM PRESSURE SENSOR CONNECTOR

1. Disconnect EVAP control system pressure sensor harness connector.
2. Check that water is not inside connectors.

D

Is the inspection result normal?

- YES >> GO TO 9.
NO >> Replace EVAP control system pressure sensor.

E

9.CHECK EVAP CONTROL SYSTEM PRESSURE SENSOR FUNCTION

Refer to [EC-303, "DTC Logic"](#) for DTC P0452, [EC-308, "DTC Logic"](#) for DTC P0453.

Is the inspection result normal?

- YES >> GO TO 10.
NO >> Replace EVAP control system pressure sensor.

F

G

10.CHECK RUBBER TUBE FOR CLOGGING

1. Disconnect rubber tube connected to EVAP canister vent control valve.
2. Check the rubber tube for clogging.

H

Is the inspection result normal?

- YES >> GO TO 11.
NO >> Clean the rubber tube using an air blower.

I

11.CHECK EVAP CANISTER VENT CONTROL VALVE

Refer to [EC-294, "Component Inspection"](#).

Is the inspection result normal?

- YES >> GO TO 12.
NO >> Replace EVAP canister vent control valve.

K

12.CHECK EVAP PURGE LINE

Inspect EVAP purge line (pipe and rubber tube). Check for evidence of leakage.

Refer to [EC-77, "System Diagram"](#).

Is the inspection result normal?

- YES >> GO TO 13.
NO >> Repair EVAP purge line.

L

M

13.CLEAN EVAP PURGE LINE

Clean EVAP purge line (pipe and rubber tube) using air blower.

>> GO TO 14.

O

14.CHECK INTERMITTENT INCIDENT

Refer to [GI-40, "Intermittent Incident"](#).

P

>> INSPECTION END

P0442 EVAP CONTROL SYSTEM

< COMPONENT DIAGNOSIS >

[VQ35DE]

P0442 EVAP CONTROL SYSTEM

DTC Logic

INFOID:000000003388052

DTC DETECTION LOGIC

This diagnosis detects leakage in the EVAP purge line using engine intake manifold vacuum. If pressure does not increase, the ECM will check for leakage in the line between the fuel tank and EVAP canister purge volume control solenoid valve, under the following "Vacuum test" conditions. The EVAP canister vent control valve is closed to shut the EVAP purge line off. The EVAP canister purge volume control solenoid valve will then be opened to depressurize the EVAP purge line using intake manifold vacuum. After this occurs, the EVAP canister purge volume control solenoid valve will be closed.

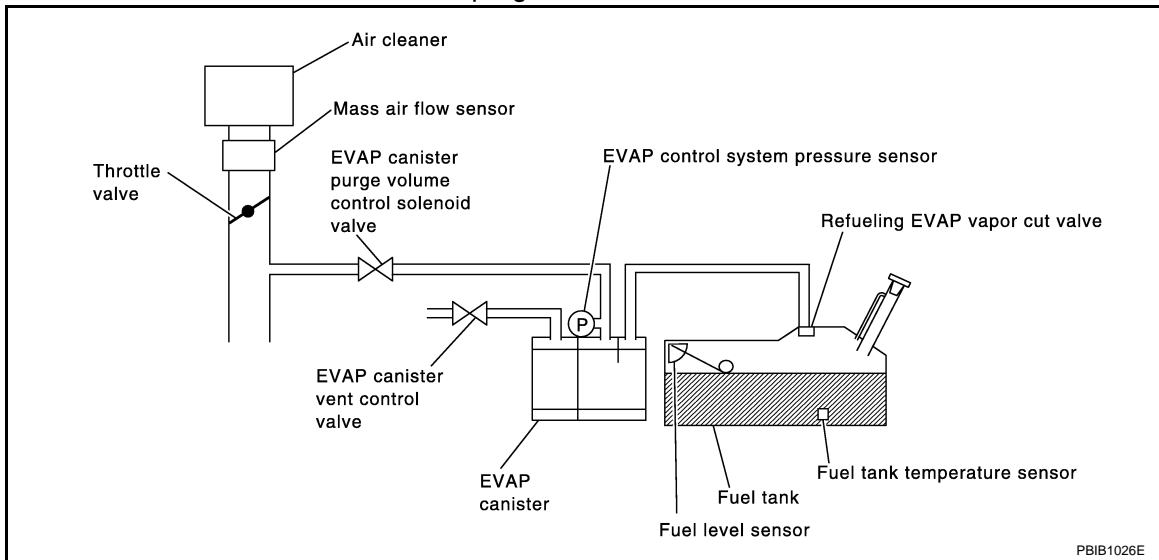

DTC No.	Trouble diagnosis name	DTC detecting condition	Possible cause
P0442	EVAP control system small leakage detected (negative pressure)	EVAP control system has a leakage, EVAP control system does not operate properly.	<ul style="list-style-type: none"> • Incorrect fuel tank vacuum relief valve • Incorrect fuel filler cap used • Fuel filler cap remains open or does not close. • Foreign matter caught in fuel filler cap. • Leakage is in line between intake manifold and EVAP canister purge volume control solenoid valve. • Foreign matter caught in EVAP canister vent control valve. • EVAP canister or fuel tank leakage • EVAP purge line (pipe and rubber tube) leakage • EVAP purge line rubber tube bent • Loose or disconnected rubber tube • EVAP canister vent control valve and the circuit • EVAP canister purge volume control solenoid valve and the circuit • Fuel tank temperature sensor • O-ring of EVAP canister vent control valve is missing or damaged • EVAP canister is saturated with water • EVAP control system pressure sensor • Fuel level sensor and the circuit • Refueling EVAP vapor cut valve • ORVR system leakage

CAUTION:

- Use only a genuine NISSAN fuel filler cap as a replacement. If an incorrect fuel filler cap is used, the MIL may illuminate.
- If the fuel filler cap is not tightened properly, the MIL may illuminate.
- Use only a genuine NISSAN rubber tube as a replacement.

DTC CONFIRMATION PROCEDURE

P0442 EVAP CONTROL SYSTEM

< COMPONENT DIAGNOSIS >

[VQ35DE]

1. PRECONDITIONING

If DTC Confirmation Procedure has been previously conducted, always perform the following before conducting the next test.

1. Turn ignition switch OFF and wait at least 10 seconds.
2. Turn ignition switch ON.
3. Turn ignition switch OFF and wait at least 10 seconds.

TESTING CONDITION:

- Perform "DTC WORK SUPPORT" when the fuel level is between 1/4 and 3/4 full, and vehicle is placed on flat level surface.
- Always perform test at a temperature of 0 to 30°C (32 to 86°F).

NOTE:

Check that EVAP hoses are connected to EVAP canister purge volume control solenoid valve properly.

Will CONSULT-III be used?

- YES >> GO TO 2.
NO >> GO TO 3.

2. PERFORM DTC CONFIRMATION PROCEDURE

With CONSULT-III

1. Turn ignition switch ON.
2. Turn ignition switch OFF and wait at least 10 seconds.
3. Turn ignition switch ON and select "DATA MONITOR" mode with CONSULT-III.
4. Check that the following conditions are met.
COOLAN TEMP/S: 0 - 70°C (32 - 158°F)
INT/A TEMP SE: 0 - 30°C (32 - 86°F)
5. Select "EVP SML LEAK P0442/P1442" of "EVAPORATIVE SYSTEM" in "DTC WORK SUPPORT" mode with CONSULT-III.

Follow the instructions displayed.

NOTE:

If the engine speed cannot be maintained within the range displayed on the CONSULT-III screen, go to [EC-12, "BASIC INSPECTION : Special Repair Requirement"](#).

Which is displayed on CONSULT-III screen?

- OK >> INSPECTION END
NG >> Go to [EC-279, "Diagnosis Procedure"](#).

3. PERFORM COMPONENT FUNCTION CHECK

With GST

NOTE:

Be sure to read the explanation of DRIVING PATTERN in [EC-524, "How to Set SRT Code"](#) before driving vehicle.

1. Start engine.
2. Drive vehicle according to DRIVING PATTERN.
3. Stop vehicle.
4. Turn ignition switch OFF and wait at least 10 seconds.
5. Turn ignition switch ON.
6. Turn ignition switch OFF and wait at least 10 seconds.
7. Turn ignition switch ON.
8. Check 1st trip DTC.

Is 1st trip DTC displayed?

- YES-1 >> P0441: Go to [EC-275, "Diagnosis Procedure"](#).
YES-2 >> P0442: Go to [EC-279, "Diagnosis Procedure"](#).
NO >> INSPECTION END

Diagnosis Procedure

INFOID:000000003388053

1. CHECK FUEL FILLER CAP DESIGN

1. Turn ignition switch OFF.

P0442 EVAP CONTROL SYSTEM

[VQ35DE]

< COMPONENT DIAGNOSIS >

2. Check for genuine NISSAN fuel filler cap design.

Is the inspection result normal?

YES >> GO TO 2.

NO >> Replace with genuine NISSAN fuel filler cap.

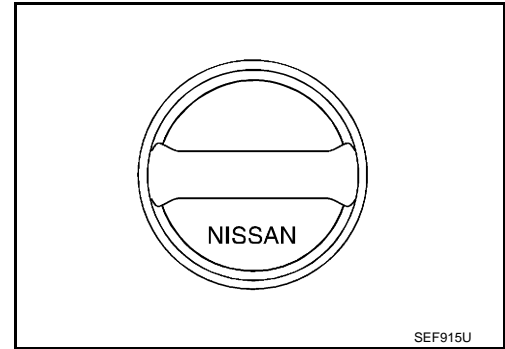

2.CHECK FUEL FILLER CAP INSTALLATION

Check that the cap is tightened properly by rotating the cap clockwise.

Is the inspection result normal?

YES >> GO TO 3.

NO >> Open fuel filler cap, then clean cap and fuel filler neck threads using air blower. Retighten until ratcheting sound is heard.

3.CHECK FUEL FILLER CAP FUNCTION

Check for air releasing sound while opening the fuel filler cap.

Is the inspection result normal?

YES >> GO TO 5.

NO >> GO TO 4.

4.CHECK FUEL TANK VACUUM RELIEF VALVE

Refer to [EC-283, "Component Inspection"](#).

Is the inspection result normal?

YES >> GO TO 5.

NO >> Replace fuel filler cap with a genuine one.

5.CHECK FOR EVAP LEAKAGE

Refer to [EC-547, "Inspection"](#).

Is there any leakage in EVAP line?

YES >> Repair or replace malfunctioning part.

NO >> GO TO 6.

6.CHECK EVAP CANISTER VENT CONTROL VALVE

Check the following.

- EVAP canister vent control valve is installed properly.
Refer to [EC-549, "Removal and Installation"](#).
- EVAP canister vent control valve.
Refer to [EC-294, "Component Inspection"](#).

Is the inspection result normal?

YES >> GO TO 7.

NO >> Repair or replace EVAP canister vent control valve and O-ring.

7.CHECK IF EVAP CANISTER IS SATURATED WITH WATER

P0442 EVAP CONTROL SYSTEM

[VQ35DE]

< COMPONENT DIAGNOSIS >

Remove EVAP canister with EVAP canister vent control valve and EVAP control system pressure sensor attached.

Does water drain from the EVAP canister?

- YES >> GO TO 8.
- NO-1 >> With CONSULT-III: GO TO 10.
- NO-2 >> Without CONSULT-III: GO TO 11.

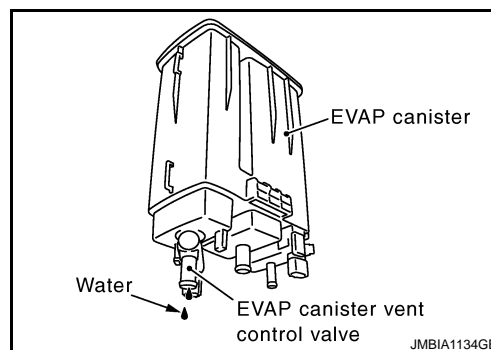

8. CHECK EVAP CANISTER

Weigh the EVAP canister with the EVAP canister vent control valve and EVAP control system pressure sensor attached.

The weight should be less than 2.1 kg (4.6 lb).

Is the inspection result normal?

- YES-1 >> With CONSULT-III: GO TO 10.
- YES-2 >> Without CONSULT-III: GO TO 11.
- NO >> GO TO 9.

9. DETECT MALFUNCTIONING PART

Check the following.

- EVAP canister for damage
- EVAP hose between EVAP canister and vehicle frame for clogging or poor connection

>> Repair hose or replace EVAP canister.

10. CHECK EVAP CANISTER PURGE VOLUME CONTROL SOLENOID VALVE OPERATION

With CONSULT-III

1. Disconnect vacuum hose from EVAP canister purge volume control solenoid valve at EVAP service port.
2. Start engine.
3. Perform "PURG VOL C/V" in "ACTIVE TEST" mode.
4. Touch "Qu" on CONSULT-III screen to increase "PURG VOL C/V" opening to 100%.
5. Check vacuum hose for vacuum.

Vacuum should exist.

Is the inspection result normal?

- YES >> GO TO 13.
- NO >> GO TO 12.

11. CHECK EVAP CANISTER PURGE VOLUME CONTROL SOLENOID VALVE OPERATION

Without CONSULT-III

1. Start engine and warm it up to normal operating temperature.
2. Stop engine.
3. Disconnect vacuum hose from EVAP canister purge volume control solenoid valve at EVAP service port.
4. Start engine and let it idle for at least 80 seconds.
5. Check vacuum hose for vacuum when revving engine up to 2,000 rpm.

Vacuum should exist.

Is the inspection result normal?

- YES >> GO TO 13.
- NO >> GO TO 12.

12. CHECK VACUUM HOSE

Check vacuum hoses for clogging or disconnection. Refer to [EC-77. "System Diagram"](#).

Is the inspection result normal?

P0442 EVAP CONTROL SYSTEM

[VQ35DE]

< COMPONENT DIAGNOSIS >

- YES >> GO TO 13.
NO >> Repair or reconnect the hose.

13.CHECK EVAP CANISTER PURGE VOLUME CONTROL SOLENOID VALVE

Refer to [EC-287, "Component Inspection"](#).

Is the inspection result normal?

- YES >> GO TO 14.
NO >> Replace EVAP canister purge volume control solenoid valve.

14.CHECK FUEL TANK TEMPERATURE SENSOR

Refer to [EC-238, "Component Inspection"](#).

Is the inspection result normal?

- YES >> GO TO 15.
NO >> Replace fuel level sensor unit and fuel pump.

15.CHECK EVAP CONTROL SYSTEM PRESSURE SENSOR

Refer to [EC-302, "Component Inspection"](#).

Is the inspection result normal?

- YES >> GO TO 16.
NO >> Replace EVAP control system pressure sensor.

16.CHECK EVAP PURGE LINE

Check EVAP purge line (pipe, rubber tube, fuel tank and EVAP canister) for cracks or improper connection.

Refer to [EC-77, "System Diagram"](#).

Is the inspection result normal?

- YES >> GO TO 17.
NO >> Repair or reconnect the hose.

17.CLEAN EVAP PURGE LINE

Clean EVAP purge line (pipe and rubber tube) using air blower.

>> GO TO 18.

18.CHECK EVAP/ORVR LINE

Check EVAP/ORVR line between EVAP canister and fuel tank for clogging, kinks, looseness and improper connection. For location, refer to [EC-457, "Description"](#).

Is the inspection result normal?

- YES >> GO TO 19.
NO >> Repair or replace hoses and tubes.

19.CHECK RECIRCULATION LINE

Check recirculation line between filler neck tube and fuel tank for clogging, kinks, cracks, looseness and improper connection.

Is the inspection result normal?

- YES >> GO TO 20.
NO >> Repair or replace hose, tube or filler neck tube.

20.CHECK REFUELING EVAP VAPOR CUT VALVE

Refer to [EC-460, "Component Inspection"](#).

Is the inspection result normal?

- YES >> GO TO 21.
NO >> Replace refueling EVAP vapor cut valve with fuel tank.

21.CHECK FUEL LEVEL SENSOR

Refer to [MWI-47, "Component Inspection"](#).

Is the inspection result normal?

- YES >> GO TO 22.

P0442 EVAP CONTROL SYSTEM

[VQ35DE]

< COMPONENT DIAGNOSIS >

NO >> Replace fuel level sensor unit and fuel pump.

22.CHECK INTERMITTENT INCIDENT

Refer to [GI-40, "Intermittent Incident"](#).

>> INSPECTION END

Component Inspection

INFOID:000000003388054

1.CHECK FUEL FILLER CAP

1. Turn ignition switch OFF.
2. Remove fuel filler cap.
3. Wipe clean valve housing.

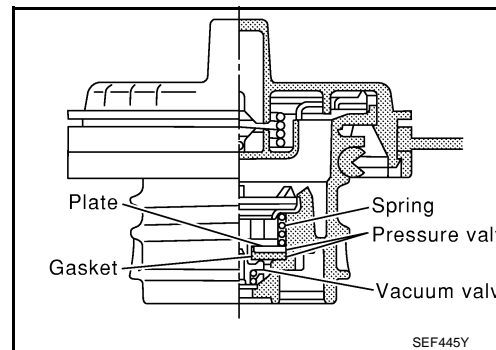

4. Install fuel filler cap adapter (commercial service tool) to fuel filler cap.
5. Check valve opening pressure and vacuum.

Pressure: 15.3 - 20.0 kPa (0.156 - 0.204 kg/cm², 2.22 - 2.90 psi)

Vacuum: -6.0 to -3.3 kPa (-0.061 to -0.034 kg/cm², -0.87 to -0.48 psi)

Is the inspection result normal?

- YES >> INSPECTION END
NO >> GO TO 2.

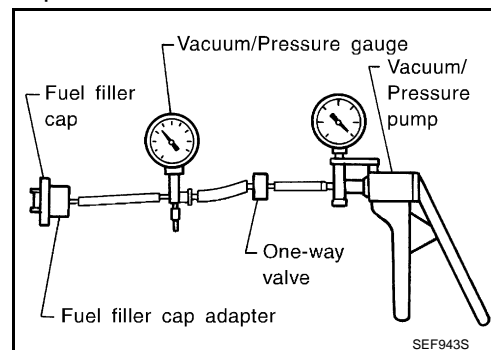

2.REPLACE FUEL FILLER CAP

Replace fuel filler cap.

CAUTION:

Use only a genuine fuel filler cap as a replacement. If an incorrect fuel filler cap is used, the MIL may illuminate.

>> INSPECTION END

P0443 EVAP CANISTER PURGE VOLUME CONTROL SOLENOID VALVE

< COMPONENT DIAGNOSIS >

[VQ35DE]

P0443 EVAP CANISTER PURGE VOLUME CONTROL SOLENOID VALVE

Description

INFOID:000000003388055

The EVAP canister purge volume control solenoid valve is used to control the flow rate of fuel vapor from the EVAP canister. The EVAP canister purge volume control solenoid valve is moved by ON/OFF pulses from the ECM. The longer the ON pulse, the greater the amount of fuel vapor that will flow through the valve.

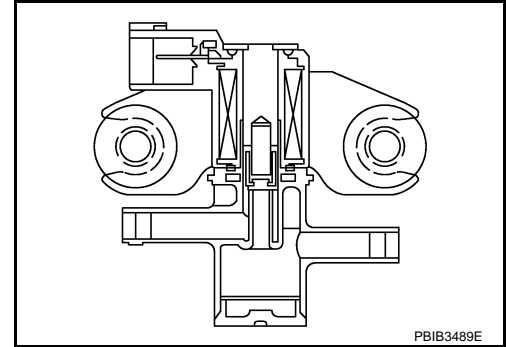

DTC Logic

INFOID:000000003388056

DTC DETECTION LOGIC

DTC No.	Trouble diagnosis name	DTC detecting condition	Possible cause
P0443	EVAP canister purge volume control solenoid valve	The canister purge flow is detected during the specified driving conditions, even when EVAP canister purge volume control solenoid valve is completely closed.	<ul style="list-style-type: none">• EVAP control system pressure sensor• EVAP canister purge volume control solenoid valve (The valve is stuck open.)• EVAP canister vent control valve• EVAP canister• Hoses (Hoses are connected incorrectly or clogged.)

DTC CONFIRMATION PROCEDURE

1. PRECONDITIONING

If DTC Confirmation Procedure has been previously conducted, always perform the following before conducting the next test.

1. Turn ignition switch OFF and wait at least 10 seconds.
2. Turn ignition switch ON.
3. Turn ignition switch OFF and wait at least 10 seconds.

TESTING CONDITION:

Always perform test at a temperature of 5°C (41°F) or more.

Will CONSULT-III be used?

- YES >> GO TO 2.
NO >> GO TO 3.

2. PERFORM DTC CONFIRMATION PROCEDURE

With CONSULT-III

1. Start engine and warm it up to normal operating temperature.
2. Turn ignition switch OFF and wait at least 10 seconds.
3. Turn ignition switch ON.
4. Turn ignition switch OFF and wait at least 10 seconds.
5. Turn ignition switch ON.
6. Select "PURG VOL C/V P1444" of "EVAPORATIVE SYSTEM" in "DTC WORK SUPPORT" mode with CONSULT-III.
7. Touch "START".
8. Start engine and let it idle until "TESTING" on CONSULT-III changes to "COMPLETED". (It will take approximately 10 seconds.)
If "TESTING" is not displayed after 5 minutes, retry from step 2.
9. Touch "SELF-DIAG RESULTS".

Which is displayed on CONSULT-III screen?

P0443 EVAP CANISTER PURGE VOLUME CONTROL SOLENOID VALVE

< COMPONENT DIAGNOSIS >

[VQ35DE]

- OK >> INSPECTION END
- NG >> Go to [EC-285, "Diagnosis Procedure"](#).

3.PERFORM DTC CONFIRMATION PROCEDURE

With GST

1. Start engine and warm it up to normal operating temperature.
2. Turn ignition switch OFF and wait at least 10 seconds.
3. Turn ignition switch ON.
4. Turn ignition switch OFF and wait at least 10 seconds.
5. Start engine and let it idle for at least 20 seconds.
6. Check 1st trip DTC.

Is 1st trip DTC displayed?

- YES >> Go to [EC-285, "Diagnosis Procedure"](#).
- NO >> INSPECTION END

Diagnosis Procedure

INFOID:000000003388057

1.CHECK EVAP CANISTER PURGE VOLUME CONTROL SOLENOID VALVE POWER SUPPLY CIRCUIT

1. Turn ignition switch OFF.
2. Disconnect EVAP canister purge volume control solenoid valve harness connector.
3. Turn ignition switch ON.
4. Check the voltage between EVAP canister purge volume control solenoid valve harness connector and ground.

EVAP canister purge volume control solenoid valve		Ground	Voltage
Connector	Terminal		
F30	1	Ground	Battery voltage

Is the inspection result normal?

- YES >> GO TO 3.
- NO >> GO TO 2.

2.DETECT MALFUNCTIONING PART

Check the following.

- Harness connectors F121, E7
- Harness for open or short between EVAP canister purge volume control solenoid valve and IPDM E/R
- Harness for open or short between EVAP canister purge volume control solenoid valve and ECM

>> Repair open circuit, short to ground or short to power in harness or connectors.

3.CHECK EVAP CANISTER PURGE VOLUME CONTROL SOLENOID VALVE OUTPUT SIGNAL CIRCUIT FOR OPEN AND SHORT

1. Turn ignition switch OFF.
2. Disconnect ECM harness connector.
3. Check the continuity between EVAP canister purge volume control solenoid valve harness connector and ECM harness connector.

EVAP canister purge volume control solenoid valve		ECM		Continuity
Connector	Terminal	Connector	Terminal	
F30	2	F7	25	Existed

4. Also check harness for short to ground and short to power.

Is the inspection result normal?

- YES >> GO TO 4.
- NO >> Repair open circuit, short to ground or short to power in harness or connectors.

P0443 EVAP CANISTER PURGE VOLUME CONTROL SOLENOID VALVE

< COMPONENT DIAGNOSIS >

[VQ35DE]

4. CHECK EVAP CONTROL SYSTEM PRESSURE SENSOR CONNECTOR

1. Disconnect EVAP control system pressure sensor harness connector.
2. Check that water is not inside connectors.

Is the inspection result normal?

- YES >> GO TO 5.
NO >> Replace EVAP control system pressure sensor.

5. CHECK EVAP CONTROL SYSTEM PRESSURE SENSOR

Refer to [EC-302, "Component Inspection"](#).

Is the inspection result normal?

- YES-1 >> With CONSULT-III: GO TO 6.
YES-2 >> Without CONSULT-III: GO TO 7.
NO >> Replace EVAP control system pressure sensor.

6. CHECK EVAP CANISTER PURGE VOLUME CONTROL SOLENOID VALVE

 **With CONSULT-III**

1. Turn ignition switch OFF.
2. Reconnect harness connectors disconnected.
3. Start engine.
4. Perform "PURG VOL C/V" in "ACTIVE TEST" mode with CONSULT-III. Check that engine speed varies according to the valve opening.

Does engine speed vary according to the valve opening?

- YES >> GO TO 8.
NO >> GO TO 7.

7. CHECK EVAP CANISTER PURGE VOLUME CONTROL SOLENOID VALVE

Refer to [EC-287, "Component Inspection"](#).

Is the inspection result normal?

- YES >> GO TO 8.
NO >> Replace EVAP canister purge volume control solenoid valve.

8. CHECK RUBBER TUBE FOR CLOGGING

1. Disconnect rubber tube connected to EVAP canister vent control valve.
2. Check the rubber tube for clogging.

Is the inspection result normal?

- YES >> GO TO 9.
NO >> Clean the rubber tube using an air blower.

9. CHECK EVAP CANISTER VENT CONTROL VALVE

Refer to [EC-294, "Component Inspection"](#).

Is the inspection result normal?

- YES >> GO TO 10.
NO >> Replace EVAP canister vent control valve.

10. CHECK IF EVAP CANISTER IS SATURATED WITH WATER

Remove EVAP canister with EVAP canister vent control valve and EVAP control system pressure sensor attached.

Does water drain from the EVAP canister?

- YES >> GO TO 11.
NO >> GO TO 13.

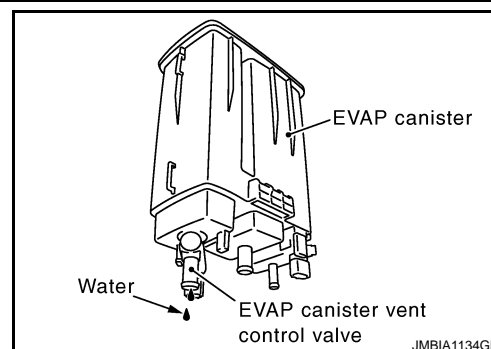

P0443 EVAP CANISTER PURGE VOLUME CONTROL SOLENOID VALVE

< COMPONENT DIAGNOSIS >

[VQ35DE]

11. CHECK EVAP CANISTER

Weigh the EVAP canister with the EVAP canister vent control valve and EVAP control system pressure sensor attached.

The weight should be less than 2.1 kg (4.6 lb).

Is the inspection result normal?

YES >> GO TO 13.

NO >> GO TO 12.

12. DETECT MALFUNCTIONING PART

Check the following.

- EVAP canister for damage
- EVAP hose between EVAP canister and vehicle frame for clogging or poor connection

>> Repair hose or replace EVAP canister.

13. CHECK INTERMITTENT INCIDENT

Refer to [GI-40. "Intermittent Incident"](#).

>> INSPECTION END

Component Inspection

INFOID:000000003388058

1. CHECK EVAP CANISTER PURGE VOLUME CONTROL SOLENOID VALVE

☑ With CONSULT-III

1. Turn ignition switch OFF.
2. Reconnect all harness connectors disconnected.
3. Disconnect EVAP purge hoses connected to EVAP canister purge volume control solenoid valve.
4. Turn ignition switch ON.
5. Select "PURG VOL C/V" in "ACTIVE TEST" mode with CONSULT-III.
6. Touch "Qd" and "Qu" on CONSULT-III screen to adjust "PURG VOL C/V" opening and check air passage continuity of EVAP canister purge volume control solenoid valve under the following conditions.

Condition (PURG VOL C/V value)	Air passage continuity between (A) and (B)
100%	Existed
0%	Not existed

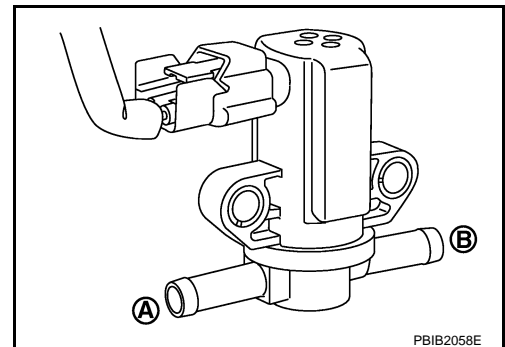

☒ Without CONSULT-III

1. Turn ignition switch OFF.
2. Disconnect EVAP canister purge volume control solenoid valve harness connector.
3. Disconnect EVAP purge hoses connected to EVAP canister purge volume control solenoid valve.
4. Check air passage continuity of EVAP canister purge volume control solenoid valve under the following conditions.

Condition	Air passage continuity between (A) and (B)
12 V direct current supply between terminals 1 and 2	Existed
No supply	Not existed

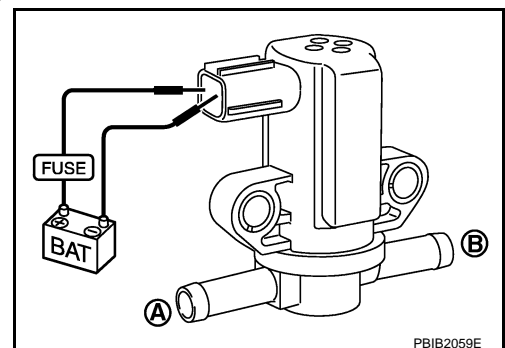

Is the inspection result normal?

YES >> INSPECTION END

P0443 EVAP CANISTER PURGE VOLUME CONTROL SOLENOID VALVE

< COMPONENT DIAGNOSIS >

[VQ35DE]

NO >> Replace EVAP canister purge volume control solenoid valve

P0444, P0445 EVAP CANISTER PURGE VOLUME CONTROL SOLENOID VALVE

< COMPONENT DIAGNOSIS >

[VQ35DE]

P0444, P0445 EVAP CANISTER PURGE VOLUME CONTROL SOLENOID VALVE

Description

INFOID:000000003597996

The EVAP canister purge volume control solenoid valve is used to control the flow rate of fuel vapor from the EVAP canister. The EVAP canister purge volume control solenoid valve is moved by ON/OFF pulses from the ECM. The longer the ON pulse, the greater the amount of fuel vapor that will flow through the valve.

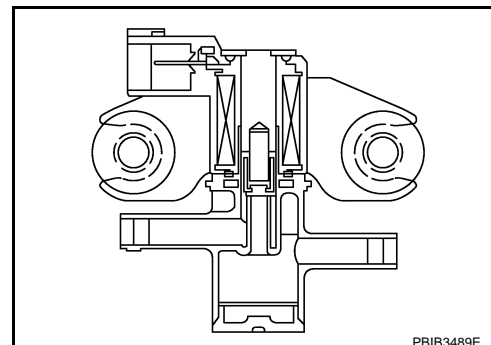

DTC Logic

INFOID:000000003388060

DTC DETECTION LOGIC

DTC No.	Trouble diagnosis name	DTC detecting condition	Possible cause
P0444	EVAP canister purge volume control solenoid valve circuit open	An excessively low voltage signal is sent to ECM through the valve	<ul style="list-style-type: none"> • Harness or connectors (The solenoid valve circuit is open or shorted.) • EVAP canister purge volume control solenoid valve
P0445	EVAP canister purge volume control solenoid valve circuit shorted	An excessively high voltage signal is sent to ECM through the valve	<ul style="list-style-type: none"> • Harness or connectors (The solenoid valve circuit is shorted.) • EVAP canister purge volume control solenoid valve

DTC CONFIRMATION PROCEDURE

1.CONDITIONING

If DTC Confirmation Procedure has been previously conducted, always perform the following before conducting the next test.

1. Turn ignition switch OFF and wait at least 10 seconds.
2. Turn ignition switch ON.
3. Turn ignition switch OFF and wait at least 10 seconds.

TESTING CONDITION:

Before performing the following procedure, confirm battery voltage is more than 11 V at idle.

>> GO TO 2.

2.PERFORM DTC CONFIRMATION PROCEDURE

1. Start engine and let it idle for at least 13 seconds.
2. Check 1st trip DTC.

Is 1st trip DTC detected?

YES >> Go to [EC-289. "Diagnosis Procedure"](#).

NO >> INSPECTION END

Diagnosis Procedure

INFOID:000000003388061

1.CHECK EVAP CANISTER PURGE VOLUME CONTROL SOLENOID VALVE POWER SUPPLY CIRCUIT

1. Turn ignition switch OFF.
2. Disconnect EVAP canister purge volume control solenoid valve harness connector.
3. Turn ignition switch ON.

P0444, P0445 EVAP CANISTER PURGE VOLUME CONTROL SOLENOID VALVE

< COMPONENT DIAGNOSIS >

[VQ35DE]

4. Check the voltage between EVAP canister purge volume control solenoid valve harness connector and ground.

EVAP canister purge volume control solenoid valve		Ground	Voltage
Connector	Terminal		
F30	1	Ground	Battery voltage

Is the inspection result normal?

YES >> GO TO 3.

NO >> GO TO 2.

2. DETECT MALFUNCTIONING PART

Check the following.

- Harness connectors F121, E7
- Harness for open or short between EVAP canister purge volume control solenoid valve and IPDM E/R
- Harness for open or short between EVAP canister purge volume control solenoid valve and ECM

>> Repair open circuit, short to ground or short to power in harness or connectors.

3. CHECK EVAP CANISTER PURGE VOLUME CONTROL SOLENOID VALVE OUTPUT SIGNAL CIRCUIT FOR OPEN AND SHORT

1. Turn ignition switch OFF.
2. Disconnect ECM harness connector.
3. Check the continuity between EVAP canister purge volume control solenoid valve harness connector and ECM harness connector.

EVAP canister purge volume control solenoid valve		ECM		Continuity
Connector	Terminal	Connector	Terminal	
F30	2	F7	25	Existed

4. Also check harness for short to ground and short to power.

Is the inspection result normal?

YES-1 >> With CONSULT-III: GO TO 4.

YES-2 >> Without CONSULT-III: GO TO 5.

NO >> Repair open circuit, short to ground or short to power in harness or connectors.

4. CHECK EVAP CANISTER PURGE VOLUME CONTROL SOLENOID VALVE OPERATION

 **With CONSULT-III**

1. Reconnect all harness connectors disconnected.
2. Start engine.
3. Perform "PURG VOL C/V" in "ACTIVE TEST" mode with CONSULT-III. Check that engine speed varies according to the valve opening.

Does engine speed vary according to the valve opening?

YES >> GO TO 6.

NO >> GO TO 5.

5. CHECK EVAP CANISTER PURGE VOLUME CONTROL SOLENOID VALVE

Refer to [EC-291, "Component Inspection"](#).

Is the inspection result normal?

YES >> GO TO 6.

NO >> Replace EVAP canister purge volume control solenoid valve.

6. CHECK INTERMITTENT INCIDENT

Refer to [GI-40, "Intermittent Incident"](#).

P0444, P0445 EVAP CANISTER PURGE VOLUME CONTROL SOLENOID VALVE

< COMPONENT DIAGNOSIS >

[VQ35DE]

>> INSPECTION END

Component Inspection

INFOID:000000003591644

1. CHECK EVAP CANISTER PURGE VOLUME CONTROL SOLENOID VALVE

With CONSULT-III

1. Turn ignition switch OFF.
2. Reconnect all harness connectors disconnected.
3. Disconnect EVAP purge hoses connected to EVAP canister purge volume control solenoid valve.
4. Turn ignition switch ON.
5. Select "PURG VOL C/V" in "ACTIVE TEST" mode with CONSULT-III.
6. Touch "Qd" and "Qu" on CONSULT-III screen to adjust "PURG VOL C/V" opening and check air passage continuity of EVAP canister purge volume control solenoid valve under the following conditions.

Condition (PURG VOL C/V value)	Air passage continuity between (A) and (B)
100%	Existed
0%	Not existed

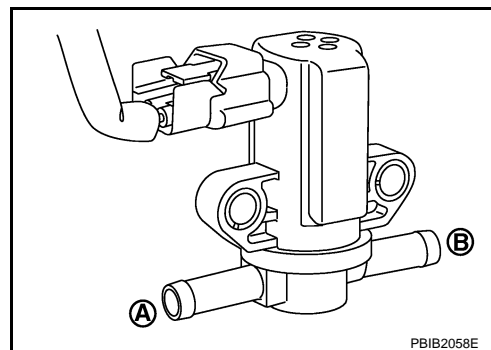

Without CONSULT-III

1. Turn ignition switch OFF.
2. Disconnect EVAP canister purge volume control solenoid valve harness connector.
3. Disconnect EVAP purge hoses connected to EVAP canister purge volume control solenoid valve.
4. Check air passage continuity of EVAP canister purge volume control solenoid valve under the following conditions.

Condition	Air passage continuity between (A) and (B)
12 V direct current supply between terminals 1 and 2	Existed
No supply	Not existed

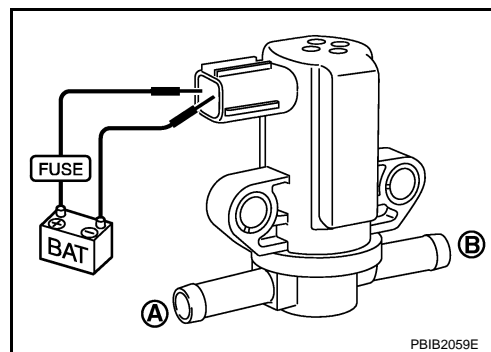

Is the inspection result normal?

YES >> INSPECTION END

NO >> Replace EVAP canister purge volume control solenoid valve

A
EC
C
D
E
F
G
H
I
J
K
L
M
N
O
P

P0447 EVAP CANISTER VENT CONTROL VALVE

< COMPONENT DIAGNOSIS >

[VQ35DE]

P0447 EVAP CANISTER VENT CONTROL VALVE

Description

INFOID:000000003388063

The EVAP canister vent control valve is located on the EVAP canister and is used to seal the canister vent.

This solenoid valve responds to signals from the ECM. When the ECM sends an ON signal, the coil in the solenoid valve is energized. A plunger will then move to seal the canister vent. The ability to seal the vent is necessary for the on board diagnosis of other evaporative emission control system components.

This solenoid valve is used only for diagnosis, and usually remains opened.

When the vent is closed, under normal purge conditions, the evaporative emission control system is depressurized and allows "EVAP Control System" diagnosis.

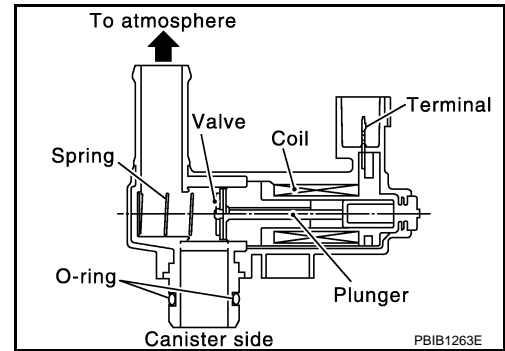

DTC Logic

INFOID:000000003388064

DTC DETECTION LOGIC

DTC No.	Trouble diagnosis name	DTC detecting condition	Possible cause
P0447	EVAP canister vent control valve circuit open	An improper voltage signal is sent to ECM through EVAP canister vent control valve.	<ul style="list-style-type: none">• Harness or connectors (The valve circuit is open or shorted.)• EVAP canister vent control valve• Hoses (Hoses are connected incorrectly or clogged.)

DTC CONFIRMATION PROCEDURE

1. PRECONDITIONING

If DTC Confirmation Procedure has been previously conducted, always perform the following before conducting the next test.

1. Turn ignition switch OFF and wait at least 10 seconds.
2. Turn ignition switch ON.
3. Turn ignition switch OFF and wait at least 10 seconds.

TESTING CONDITION:

Before performing the following procedure, confirm battery voltage is more than 11 V at idle.

>> GO TO 2.

2. PERFORM DTC CONFIRMATION PROCEDURE

1. Start engine and wait at least 8 seconds.
2. Check 1st trip DTC.

Is 1st trip DTC detected?

- YES >> Go to [EC-292, "Diagnosis Procedure"](#).
NO >> INSPECTION END

Diagnosis Procedure

INFOID:000000003388065

1. INSPECTION START

Will CONSULT-III be used?

Will CONSULT-III be used?

- YES >> GO TO 2.
NO >> GO TO 3.

2. CHECK EVAP CANISTER VENT CONTROL VALVE CIRCUIT

With CONSULT-III

P0447 EVAP CANISTER VENT CONTROL VALVE

[VQ35DE]

< COMPONENT DIAGNOSIS >

1. Turn ignition switch OFF and then ON.
2. Select "VENT CONTROL/V" in "ACTIVE TEST" mode with CONSULT-III.
3. Touch "ON/OFF" on CONSULT-III screen.
4. Check for operating sound of the valve.

Clicking sound should be heard.

Is the inspection result normal?

- YES >> GO TO 7.
NO >> GO TO 3.

3.CHECK EVAP CANISTER VENT CONTROL VALVE POWER SUPPLY CIRCUIT

1. Turn ignition switch OFF.
2. Disconnect EVAP canister vent control valve harness connector.
3. Turn ignition switch ON.
4. Check the voltage between EVAP canister vent control valve harness connector and ground.

EVAP canister vent control valve		Ground	Voltage
Connector	Terminal		
B65	1	Ground	Battery voltage

Is the inspection result normal?

- YES >> GO TO 5.
NO >> GO TO 4.

4.DETECT MALFUNCTIONING PART

Check the following.

- Harness connectors F121, E7
- Harness connectors E104, B4
- Harness for open or short between EVAP canister vent control valve and IPDM E/R

>> Repair open circuit, short to ground or short to power in harness or connectors.

5.CHECK EVAP CANISTER VENT CONTROL VALVE OUTPUT SIGNAL CIRCUIT FOR OPEN AND SHORT

1. Turn ignition switch OFF.
2. Disconnect ECM harness connector.
3. Check the continuity between ECM harness connector and EVAP canister vent control valve harness connector.
Refer to Wiring Diagram.

EVAP canister vent control valve		ECM		Continuity
Connector	Terminal	Connector	Terminal	
B65	2	E16	109	Existed

4. Also check harness for short to ground and short to power.

Is the inspection result normal?

- YES >> GO TO 7.
NO >> GO TO 6.

6.DETECT MALFUNCTIONING PART

Check the following.

- Harness connectors E104, B4
- Harness for open or short between EVAP canister vent control valve and ECM

>> Repair open circuit, short to ground or short to power in harness or connectors.

7.CHECK RUBBER TUBE FOR CLOGGING

1. Disconnect rubber tube connected to EVAP canister vent control valve.

P0447 EVAP CANISTER VENT CONTROL VALVE

[VQ35DE]

< COMPONENT DIAGNOSIS >

2. Check the rubber tube for clogging.

Is the inspection result normal?

YES >> GO TO 8.

NO >> Clean the rubber tube using an air blower.

8.CHECK EVAP CANISTER VENT CONTROL VALVE

Refer to [EC-294, "Component Inspection"](#).

Is the inspection result normal?

YES >> GO TO 9.

NO >> Replace EVAP canister vent control valve.

9.CHECK INTERMITTENT INCIDENT

Refer to [GI-40, "Intermittent Incident"](#).

>> INSPECTION END

Component Inspection

INFOID:000000003388066

1.CHECK EVAP CANISTER VENT CONTROL VALVE-I

1. Remove EVAP canister vent control valve from EVAP canister.
2. Check portion (A) of EVAP canister vent control valve for rust.

Is it rusted?

YES >> Replace EVAP canister vent control valve.

NO >> GO TO 2.

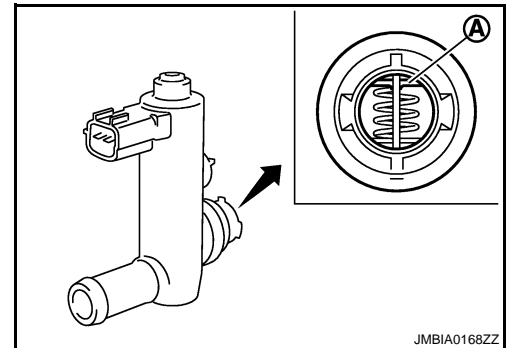

JMBIA0168ZZ

2.CHECK EVAP CANISTER VENT CONTROL VALVE-II

Ⓜ With CONSULT-III

1. Reconnect harness connectors disconnected.
2. Turn ignition switch ON.
3. Perform "VENT CONTROL/V" in "ACTIVE TEST" mode.
4. Check air passage continuity and operation delay time.
Check that new O-ring is installed properly.

Condition VENT CONTROL/V	Air passage continuity between (A) and (B)
ON	Not existed
OFF	Existed

Operation takes less than 1 second.

ⓧ Without CONSULT-III

1. Disconnect EVAP canister vent control valve harness connector.
2. Check air passage continuity and operation delay time under the following conditions.

Check that new O-ring is installed properly.

Condition	Air passage continuity between (A) and (B)
12 V direct current supply between terminals 1 and 2	Not existed
OFF	Existed

Operation takes less than 1 second.

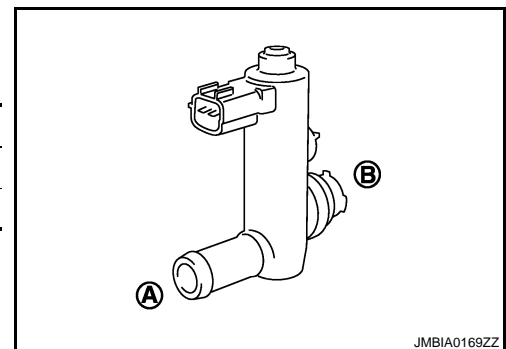

JMBIA0169ZZ

P0447 EVAP CANISTER VENT CONTROL VALVE

[VQ35DE]

< COMPONENT DIAGNOSIS >

Is the inspection result normal?

- YES >> INSPECTION END
- NO >> GO TO 3.

3. CHECK EVAP CANISTER VENT CONTROL VALVE-III

With CONSULT-III

1. Clean the air passage [portion (A) to (B)] of EVAP canister vent control valve using an air blower.
2. Perform "VENT CONTROL/V" in "ACTIVE TEST" mode.
3. Check air passage continuity and operation delay time.
Check that new O-ring is installed properly.

Condition VENT CONTROL/V	Air passage continuity between (A) and (B)
ON	No
OFF	Yes

Operation takes less than 1 second.

Without CONSULT-III

1. Clean the air passage [portion (A) to (B)] of EVAP canister vent control valve using an air blower.
2. Check air passage continuity and operation delay time under the following conditions.
Check that new O-ring is installed properly.

Condition	Air passage continuity between (A) and (B)
12 V direct current supply between terminals (1) and (2)	No
OFF	Yes

Operation takes less than 1 second.

Is the inspection result normal?

- YES >> INSPECTION END
- NO >> Replace EVAP canister vent control valve

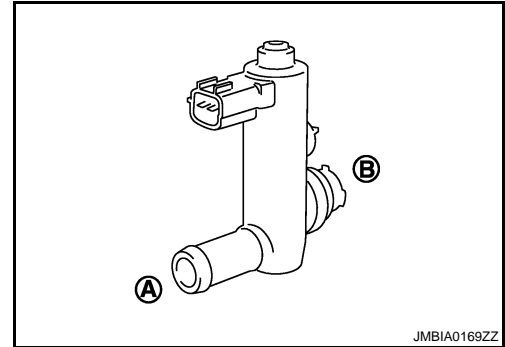

A
EC
C
D
E
F
G
H
I
J
K
L
M
N
O
P

P0448 EVAP CANISTER VENT CONTROL VALVE

< COMPONENT DIAGNOSIS >

[VQ35DE]

P0448 EVAP CANISTER VENT CONTROL VALVE

Description

INFOID:000000003591645

The EVAP canister vent control valve is located on the EVAP canister and is used to seal the canister vent.

This solenoid valve responds to signals from the ECM. When the ECM sends an ON signal, the coil in the solenoid valve is energized. A plunger will then move to seal the canister vent. The ability to seal the vent is necessary for the on board diagnosis of other evaporative emission control system components.

This solenoid valve is used only for diagnosis, and usually remains opened.

When the vent is closed, under normal purge conditions, the evaporative emission control system is depressurized and allows "EVAP Control System" diagnosis.

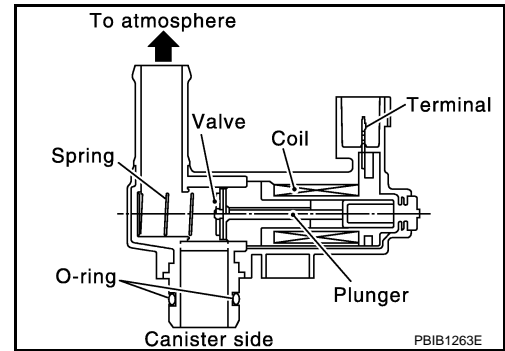

DTC Logic

INFOID:000000003388068

DTC DETECTION LOGIC

DTC No.	Trouble diagnosis name	DTC detecting condition	Possible cause
P0448	EVAP canister vent control valve close	EVAP canister vent control valve remains closed under specified driving conditions.	<ul style="list-style-type: none">• EVAP canister vent control valve• EVAP control system pressure sensor and the circuit• Blocked rubber tube to EVAP canister vent control valve• EVAP canister is saturated with water

DTC CONFIRMATION PROCEDURE

1. PRECONDITIONING

If DTC Confirmation Procedure has been previously conducted, always perform the following before conducting the next test.

1. Turn ignition switch OFF and wait at least 10 seconds.
2. Turn ignition switch ON.
3. Turn ignition switch OFF and wait at least 10 seconds.

>> GO TO 2.

2. PERFORM DTC CONFIRMATION PROCEDURE

With CONSULT-III

1. Turn ignition switch ON and wait at least 5 seconds.
2. Turn ignition switch OFF and wait at least 10 seconds.
3. Turn ignition switch ON and select "DATA MONITOR" mode with CONSULT-III.
4. Start engine and let it idle for at least 1 minute.
5. Repeat next procedures 3 times.
 - Increase the engine speed up to 3,000 to 3,500 rpm and keep it for 2 minutes and 50 seconds to 3 minutes.

Never exceed 3 minutes.

- Fully released accelerator pedal and keep engine idle for about 5 seconds.
6. Repeat next procedure 20 times.
 - Quickly increase the engine speed up to 4,000 to 4,500 rpm or more and keep it for 25 to 30 seconds.

P0448 EVAP CANISTER VENT CONTROL VALVE

[VQ35DE]

< COMPONENT DIAGNOSIS >

- Fully released accelerator pedal and keep engine idle for at least 35 seconds.

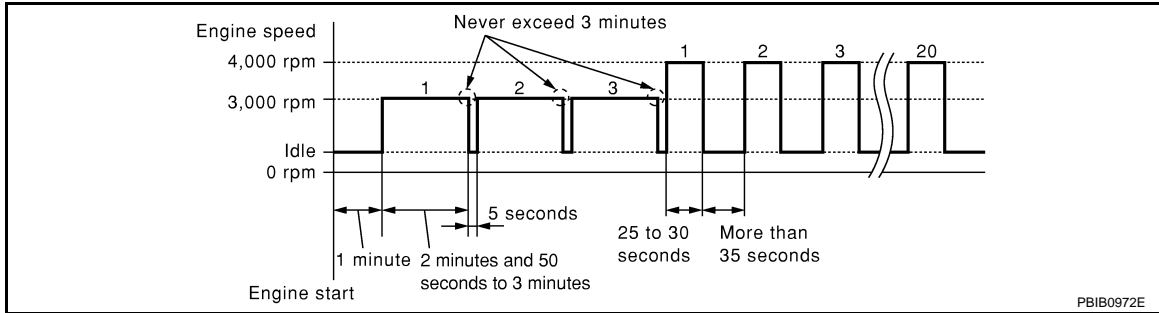

7. Check 1st trip DTC.

Is 1st trip DTC detected?

- YES >> Go to [EC-297. "Diagnosis Procedure"](#).
- NO >> INSPECTION END

Diagnosis Procedure

INFOID:000000003388069

1. CHECK RUBBER TUBE

1. Turn ignition switch OFF.
2. Disconnect rubber tube connected to EVAP canister vent control valve.
3. Check the rubber tube for clogging.

Is the inspection result normal?

- YES >> GO TO 2.
- NO >> Clean rubber tube using an air blower.

2. CHECK EVAP CANISTER VENT CONTROL VALVE

Refer to [EC-298. "Component Inspection"](#).

Is the inspection result normal?

- YES >> GO TO 3.
- NO >> Replace EVAP canister vent control valve.

3. CHECK IF EVAP CANISTER SATURATED WITH WATER

1. Remove EVAP canister with EVAP canister vent control valve and EVAP control system pressure sensor attached.
2. Check if water will drain from the EVAP canister.

Does water drain from the EVAP canister?

- YES >> GO TO 4.
- NO >> GO TO 6.

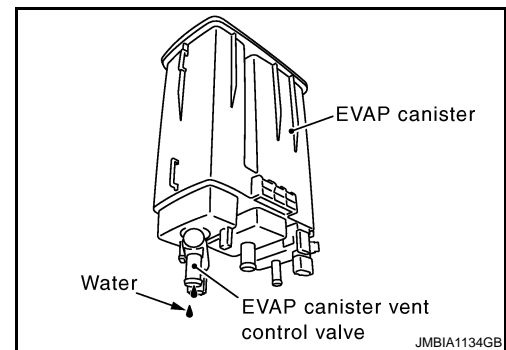

4. CHECK EVAP CANISTER

Weigh the EVAP canister with the EVAP canister vent control valve and EVAP control system pressure sensor attached.

The weight should be less than 2.1 kg (4.6 lb).

Is the inspection result normal?

- YES >> GO TO 6.
- NO >> GO TO 5.

5. DETECT MALFUNCTIONING PART

Check the following.

- EVAP canister for damage

P0448 EVAP CANISTER VENT CONTROL VALVE

[VQ35DE]

< COMPONENT DIAGNOSIS >

- EVAP hose between EVAP canister and vehicle frame for clogging or poor connection

>> Repair hose or replace EVAP canister.

6. CHECK EVAP CONTROL SYSTEM PRESSURE SENSOR CONNECTOR

1. Disconnect EVAP control system pressure sensor harness connector.
2. Check that water is not inside connectors.

Is the inspection result normal?

- YES >> GO TO 7.
NO >> Replace EVAP control system pressure sensor.

7. CHECK EVAP CONTROL SYSTEM PRESSURE SENSOR

Refer to [EC-302. "Component Inspection"](#).

Is the inspection result normal?

- YES >> GO TO 8.
NO >> Replace EVAP control system pressure sensor.

8. CHECK INTERMITTENT INCIDENT

Refer to [GI-40. "Intermittent Incident"](#).

>> INSPECTION END

Component Inspection

INFOID:000000003733511

1. CHECK EVAP CANISTER VENT CONTROL VALVE-I

1. Remove EVAP canister vent control valve from EVAP canister.
2. Check portion (A) of EVAP canister vent control valve for rust.

Is it rusted?

- YES >> Replace EVAP canister vent control valve.
NO >> GO TO 2.

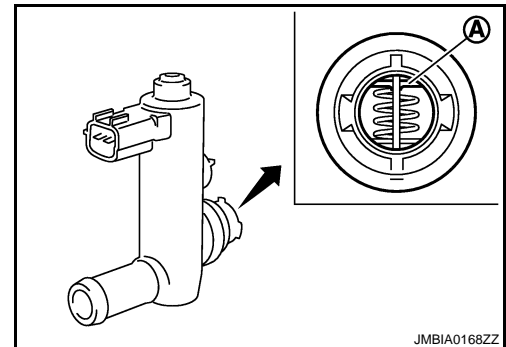

2. CHECK EVAP CANISTER VENT CONTROL VALVE-II

Ⓟ With CONSULT-III

1. Reconnect harness connectors disconnected.
2. Turn ignition switch ON.
3. Perform "VENT CONTROL/V" in "ACTIVE TEST" mode.
4. Check air passage continuity and operation delay time.
Check that new O-ring is installed properly.

Condition VENT CONTROL/V	Air passage continuity between (A) and (B)
ON	Not existed
OFF	Existed

Operation takes less than 1 second.

ⓧ Without CONSULT-III

1. Disconnect EVAP canister vent control valve harness connector.
2. Check air passage continuity and operation delay time under the following conditions.

Check that new O-ring is installed properly.

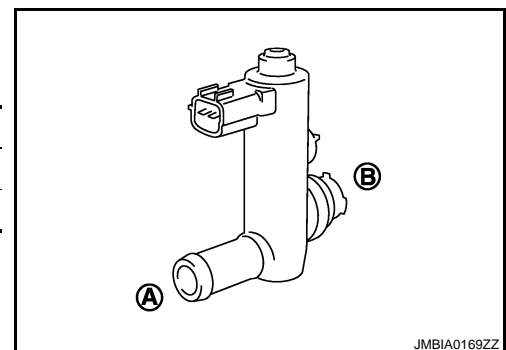

P0448 EVAP CANISTER VENT CONTROL VALVE

[VQ35DE]

< COMPONENT DIAGNOSIS >

Condition	Air passage continuity between (A) and (B)
12 V direct current supply between terminals 1 and 2	Not existed
OFF	Existed

Operation takes less than 1 second.

Is the inspection result normal?

- YES >> INSPECTION END
 NO >> GO TO 3.

3. CHECK EVAP CANISTER VENT CONTROL VALVE-III

④ With CONSULT-III

1. Clean the air passage [portion (A) to (B)] of EVAP canister vent control valve using an air blower.
2. Perform "VENT CONTROL/V" in "ACTIVE TEST" mode.
3. Check air passage continuity and operation delay time.
Check that new O-ring is installed properly.

Condition VENT CONTROL/V	Air passage continuity between (A) and (B)
ON	No
OFF	Yes

Operation takes less than 1 second.

⊗ Without CONSULT-III

1. Clean the air passage [portion (A) to (B)] of EVAP canister vent control valve using an air blower.
2. Check air passage continuity and operation delay time under the following conditions.
Check that new O-ring is installed properly.

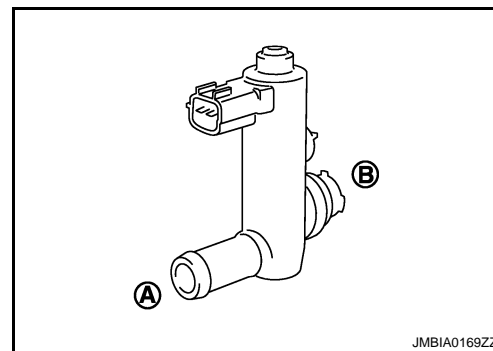

Condition	Air passage continuity between (A) and (B)
12 V direct current supply between terminals (1) and (2)	No
OFF	Yes

Operation takes less than 1 second.

Is the inspection result normal?

- YES >> INSPECTION END
 NO >> Replace EVAP canister vent control valve

P0451 EVAP CONTROL SYSTEM PRESSURE SENSOR

< COMPONENT DIAGNOSIS >

[VQ35DE]

P0451 EVAP CONTROL SYSTEM PRESSURE SENSOR

Description

INFOID:000000003388071

The EVAP control system pressure sensor detects pressure in the purge line. The sensor output voltage to the ECM increases as pressure increases.

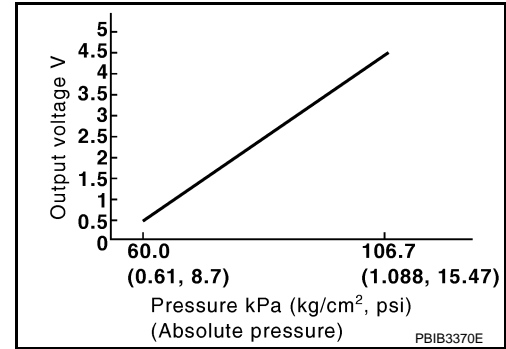

DTC Logic

INFOID:000000003388072

DTC DETECTION LOGIC

DTC No.	Trouble diagnosis name	DTC detecting condition	Possible cause
P0451	EVAP control system pressure sensor performance	ECM detects a sloshing signal from the EVAP control system pressure sensor	<ul style="list-style-type: none">• Harness or connectors (EVAP control system pressure sensor circuit is shorted.) [CKP sensor (POS) circuit is shorted.] (APP sensor 2 circuit is shorted.) (Refrigerant pressure sensor circuit is shorted.)• EVAP control system pressure sensor• Crankshaft position sensor (POS)• Accelerator pedal position sensor• Refrigerant pressure sensor

DTC CONFIRMATION PROCEDURE

1. PRECONDITIONING

If DTC Confirmation Procedure has been previously conducted, always perform the following before conducting the next test.

1. Turn ignition switch OFF and wait at least 10 seconds.
2. Turn ignition switch ON.
3. Turn ignition switch OFF and wait at least 10 seconds.

>> GO TO 2.

2. PERFORM DTC CONFIRMATION PROCEDURE

1. Start engine and wait at least 40 seconds.
NOTE:
Do not depress accelerator pedal even slightly.
2. Check 1st trip DTC.

Is 1st trip DTC detected?

- YES >> Go to [EC-300, "Diagnosis Procedure"](#).
NO >> INSPECTION END

Diagnosis Procedure

INFOID:000000003388073

1. CHECK GROUND CONNECTION

1. Turn ignition switch OFF.
2. Check ground connection E38. Refer to Ground Inspection in [GI-43, "Circuit Inspection"](#).

Is the inspection result normal?

P0451 EVAP CONTROL SYSTEM PRESSURE SENSOR

[VQ35DE]

< COMPONENT DIAGNOSIS >

- YES >> GO TO 2.
NO >> Repair or replace ground connection.

2.CHECK EVAP CONTROL SYSTEM PRESSURE SENSOR CONNECTOR FOR WATER

1. Disconnect EVAP control system pressure sensor harness connector.
2. Check that water is not inside connectors.

Is the inspection result normal?

- YES >> GO TO 3.
NO >> Repair or replace harness connector.

3.CHECK EVAP CONTROL SYSTEM PRESSURE SENSOR POWER SUPPLY CIRCUIT

1. Turn ignition switch ON.
2. Check the voltage between EVAP control system pressure sensor harness connector and ground.

EVAP control system pressure sensor		Ground	Voltage (V)
Connector	Terminal		
B17	3	Ground	Approx. 5

Is the inspection result normal?

- YES >> GO TO 8.
NO >> GO TO 4.

4.CHECK SENSOR POWER SUPPLY CIRCUIT

Check harness for short to power and short to ground, between the following terminals.

ECM		Sensor		
Connector	Terminal	Name	Connector	Terminal
F8	72	Refrigerant pressure sensor	E300	1
	76	CKP sensor (POS)	F20	1
E16	87	APP sensor	E110	5
	91	EVAP control system pressure sensor	B17	3

Is the inspection result normal?

- YES >> GO TO 5.
NO >> Repair short to ground or short to power in harness or connectors.

5.CHECK COMPONENTS

Check the following.

- Crankshaft position sensor (POS) (Refer to [EC-263, "Component Inspection"](#).)
- Refrigerant pressure sensor (Refer to [EC-463, "Diagnosis Procedure"](#).)

Is the inspection result normal?

- YES >> GO TO 6.
NO >> Replace malfunctioning components.

6.CHECK APP SENSOR

Refer to [EC-415, "Component Inspection"](#).

Is the inspection result normal?

- YES >> GO TO 9.
NO >> GO TO 7.

7.REPLACE ACCELERATOR PEDAL ASSEMBLY

1. Replace accelerator pedal assembly.
2. Go to [EC-415, "Special Repair Requirement"](#).

>> INSPECTION END

8.CHECK EVAP CONTROL SYSTEM PRESSURE SENSOR

P0451 EVAP CONTROL SYSTEM PRESSURE SENSOR

[VQ35DE]

< COMPONENT DIAGNOSIS >

Refer to [EC-302. "Component Inspection"](#).

Is the inspection result normal?

YES >> GO TO 9.

NO >> Replace EVAP control system pressure sensor.

9.CHECK INTERMITTENT INCIDENT

Refer to [GI-40. "Intermittent Incident"](#).

>> INSPECTION END

Component Inspection

INFOID:000000003388078

1.CHECK EVAP CONTROL SYSTEM PRESSURE SENSOR

1. Turn ignition switch OFF.
2. Remove EVAP control system pressure sensor with its harness connector.
Always replace O-ring with a new one.
3. Install a vacuum pump to EVAP control system pressure sensor.
4. Turn ignition switch ON and check output voltage between ECM terminals under the following conditions.

Connector	ECM		Applied vacuum kPa (kg/cm ² , psi)	Voltage
	+	-		
	Terminal	Terminal		
E16	86 (EVAP control system pressure sensor signal)	96 (Sensor ground)	Not applied	1.8 - 4.8 V
			-26.7 (-0.272, -3.87)	2.1 to 2.5 V lower than above value

CAUTION:

- **Always calibrate the vacuum pump gauge when using it.**
- **Never apply below -93.3 kPa (-0.952 kg/cm², -13.53 psi) or pressure over 101.3 kPa (1.033 kg/cm², 14.69 psi).**

Is the inspection result normal?

YES >> INSPECTION END

NO >> Replace EVAP control system pressure sensor

P0452 EVAP CONTROL SYSTEM PRESSURE SENSOR

< COMPONENT DIAGNOSIS >

[VQ35DE]

P0452 EVAP CONTROL SYSTEM PRESSURE SENSOR

Description

INFOID:000000003591654

The EVAP control system pressure sensor detects pressure in the purge line. The sensor output voltage to the ECM increases as pressure increases.

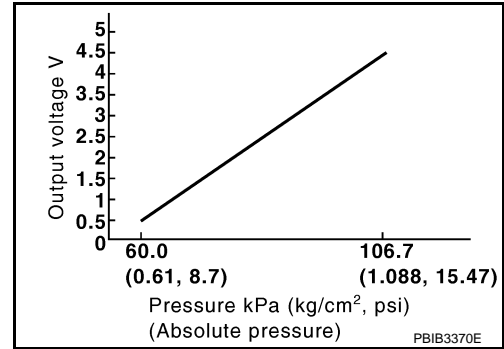

DTC Logic

INFOID:000000003388076

DTC DETECTION LOGIC

DTC No.	Trouble diagnosis name	DTC detecting condition	Possible cause
P0452	EVAP control system pressure sensor low input	An excessively low voltage from the sensor is sent to ECM.	<ul style="list-style-type: none"> Harness or connectors (The sensor circuit is open or shorted.) [CKP sensor (POS) circuit is shorted.] (APP sensor 2 circuit is shorted.) (Refrigerant pressure sensor circuit is shorted.) EVAP control system pressure sensor Crankshaft position sensor (POS) Accelerator pedal position sensor Refrigerant pressure sensor

DTC CONFIRMATION PROCEDURE

1. PRECONDITIONING

If DTC Confirmation Procedure has been previously conducted, always perform the following before conducting the next test.

1. Turn ignition switch OFF and wait at least 10 seconds.
2. Turn ignition switch ON.
3. Turn ignition switch OFF and wait at least 10 seconds.

TESTING CONDITION:

Always perform test at a temperature of 5°C (41°F) or more.

>> GO TO 2.

2. PERFORM DTC CONFIRMATION PROCEDURE

With CONSULT-III

1. Start engine and warm it up to normal operating temperature.
2. Turn ignition switch OFF and wait at least 10 seconds.
3. Turn ignition switch ON.
4. Turn ignition switch OFF and wait at least 10 seconds.
5. Turn ignition switch ON.
6. Select "DATA MONITOR" mode with CONSULT-III.
7. Check that "FUEL T/TMP SE" is more than 0°C (32°F).
8. Start engine and wait at least 20 seconds.
9. Check 1st trip DTC.

With GST

1. Start engine and warm it up to normal operating temperature.
2. Set voltmeter probes to ECM harness connector terminals under the following conditions.

P0452 EVAP CONTROL SYSTEM PRESSURE SENSOR

< COMPONENT DIAGNOSIS >

[VQ35DE]

ECM		
Connector	+	-
	Terminal	Terminal
E16	95 (Fuel tank temperature sensor signal)	104 (Sensor ground)

3. Check that the voltage is less than 4.2 V.
4. Turn ignition switch OFF and wait at least 10 seconds.
5. Turn ignition switch ON.
6. Turn ignition switch OFF and wait at least 10 seconds.
7. Start engine and wait at least 20 seconds.
8. Check 1st trip DTC.

Is 1st trip DTC detected?

- YES >> Go to [EC-304, "Diagnosis Procedure"](#).
 NO >> INSPECTION END

Diagnosis Procedure

INFOID:000000003388077

1.CHECK GROUND CONNECTION

1. Turn ignition switch OFF.
2. Check ground connection E38. Refer to Ground Inspection in [GI-43, "Circuit Inspection"](#).

Is the inspection result normal?

- YES >> GO TO 2.
 NO >> Repair or replace ground connection.

2.CHECK CONNECTOR

1. Disconnect EVAP control system pressure sensor harness connector.
2. Check that water is not inside connector.

Is the inspection result normal?

- YES >> GO TO 3.
 NO >> Repair or replace harness connector.

3.CHECK EVAP CONTROL SYSTEM PRESSURE SENSOR POWER SUPPLY CIRCUIT-I

1. Turn ignition switch ON.
2. Check the voltage between EVAP control system pressure sensor harness connector and ground.

EVAP control system pressure sensor		Ground	Voltage (V)
Connector	Terminal		
B17	3	Ground	Approx. 5

Is the inspection result normal?

- YES >> GO TO 10.
 NO >> GO TO 4.

4.CHECK EVAP CONTROL SYSTEM PRESSURE SENSOR POWER SUPPLY CIRCUIT-II

1. Turn ignition switch OFF.
2. Disconnect ECM harness connector.
3. Check the continuity between EVAP control system pressure sensor harness connector and ECM harness connector.

EVAP control system pressure sensor		ECM		Continuity
Connector	Terminal	Connector	Terminal	
B17	3	E16	91	Existed

Is the inspection result normal?

- YES >> GO TO 6.

P0452 EVAP CONTROL SYSTEM PRESSURE SENSOR

< COMPONENT DIAGNOSIS >

[VQ35DE]

NO >> GO TO 5.

5. DETECT MALFUNCTIONING PART

Check the following.

- Harness connectors B4, E104
- Harness for open or short between EVAP control system pressure sensor and ECM

>> Repair open circuit.

6. CHECK SENSOR POWER SUPPLY CIRCUIT

Check harness for short to power and short to ground, between the following terminals.

ECM		Sensor		
Connector	Terminal	Name	Connector	Terminal
F8	72	Refrigerant pressure sensor	E300	1
	76	CKP sensor (POS)	F20	1
E16	87	APP sensor	E110	5
	91	EVAP control system pressure sensor	B17	3

Is the inspection result normal?

YES >> GO TO 7.

NO >> Repair short to ground or short to power in harness or connectors.

7. CHECK COMPONENTS

Check the following.

- Crankshaft position sensor (POS) (Refer to [EC-263, "Component Inspection"](#).)
- Refrigerant pressure sensor (Refer to [EC-463, "Diagnosis Procedure"](#).)

Is the inspection result normal?

YES >> GO TO 8.

NO >> Replace malfunctioning components.

8. CHECK APP SENSOR

Refer to [EC-415, "Component Inspection"](#).

Is the inspection result normal?

YES >> GO TO 15.

NO >> GO TO 9.

9. REPLACE ACCELERATOR PEDAL ASSEMBLY

1. Replace accelerator pedal assembly.
2. Refer to [EC-415, "Special Repair Requirement"](#).

>> INSPECTION END

10. CHECK EVAP CONTROL SYSTEM PRESSURE SENSOR GROUND CIRCUIT FOR OPEN AND SHORT

1. Turn ignition switch OFF.
2. Disconnect ECM harness connector.
3. Check the continuity between EVAP control system pressure sensor harness connector and ECM harness connector.

EVAP control system pressure sensor		ECM		Continuity
Connector	Terminal	Connector	Terminal	
B17	1	E16	96	Existed

4. Also check harness for short to ground and short to power.

Is the inspection result normal?

P0452 EVAP CONTROL SYSTEM PRESSURE SENSOR

[VQ35DE]

< COMPONENT DIAGNOSIS >

- YES >> GO TO 12.
NO >> GO TO 11.

11. DETECT MALFUNCTIONING PART

Check the following.

- Harness connectors B4, E104
- Harness for open or short between EVAP control system pressure sensor and ECM

>> Repair open circuit, short to ground or short to power in harness or connectors.

12. CHECK EVAP CONTROL SYSTEM PRESSURE SENSOR INPUT SIGNAL CIRCUIT FOR OPEN AND SHORT

1. Check the continuity between EVAP control system pressure sensor harness connector and ECM harness connector.

EVAP control system pressure sensor		ECM		Continuity
Connector	Terminal	Connector	Terminal	
B17	2	E16	86	Existed

2. Also check harness for short to ground and short to power.

Is the inspection result normal?

- YES >> GO TO 14.
NO >> GO TO 13.

13. DETECT MALFUNCTIONING PART

Check the following.

- Harness connectors B4, E104
- Harness for open or short between EVAP control system pressure sensor and ECM

>> Repair open circuit, short to ground or short to power in harness or connectors.

14. CHECK EVAP CONTROL SYSTEM PRESSURE SENSOR

Refer to [EC-306, "Component Inspection"](#).

Is the inspection result normal?

- YES >> GO TO 15.
NO >> Replace EVAP control system pressure sensor.

15. CHECK INTERMITTENT INCIDENT

Refer to [GI-40, "Intermittent Incident"](#).

>> INSPECTION END

Component Inspection

INFOID:000000003625710

1. CHECK EVAP CONTROL SYSTEM PRESSURE SENSOR

1. Turn ignition switch OFF.
2. Remove EVAP control system pressure sensor with its harness connector.
Always replace O-ring with a new one.
3. Install a vacuum pump to EVAP control system pressure sensor.
4. Turn ignition switch ON and check output voltage between ECM terminals under the following conditions.

P0452 EVAP CONTROL SYSTEM PRESSURE SENSOR

< COMPONENT DIAGNOSIS >

[VQ35DE]

ECM			Applied vacuum kPa (kg/cm ² , psi)	Voltage
Connector	+	-		
	Terminal	Terminal		
E16	86 (EVAP control system pressure sensor signal)	96 (Sensor ground)	Not applied	1.8 - 4.8 V
			-26.7 (-0.272, -3.87)	2.1 to 2.5 V lower than above value

CAUTION:

- Always calibrate the vacuum pump gauge when using it.
- Never apply below -93.3 kPa (-0.952 kg/cm², -13.53 psi) or pressure over 101.3 kPa (1.033 kg/cm², 14.69 psi).

Is the inspection result normal?

- YES >> INSPECTION END
 NO >> Replace EVAP control system pressure sensor

A
EC
C
D
E
F
G
H
I
J
K
L
M
N
O
P

P0453 EVAP CONTROL SYSTEM PRESSURE SENSOR

< COMPONENT DIAGNOSIS >

[VQ35DE]

P0453 EVAP CONTROL SYSTEM PRESSURE SENSOR

Description

INFOID:000000003591658

The EVAP control system pressure sensor detects pressure in the purge line. The sensor output voltage to the ECM increases as pressure increases.

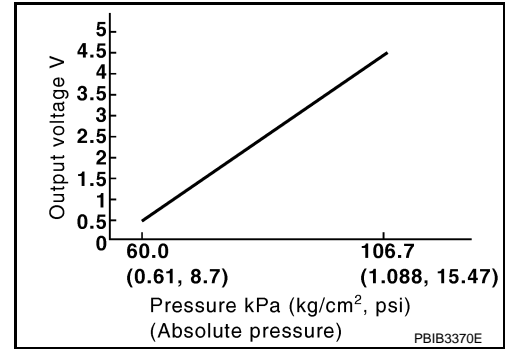

DTC Logic

INFOID:000000003388080

DTC DETECTION LOGIC

DTC No.	Trouble diagnosis name	DTC detecting condition	Possible cause
P0453	EVAP control system pressure sensor high input	An excessively high voltage from the sensor is sent to ECM.	<ul style="list-style-type: none"> • Harness or connectors (The sensor circuit is open or shorted.) [CKP sensor (POS) circuit is shorted.] (APP sensor 2 circuit is shorted.) (Refrigerant pressure sensor circuit is shorted.) • EVAP control system pressure sensor • Crankshaft position sensor (POS) • Accelerator pedal position sensor • Refrigerant pressure sensor • EVAP canister vent control valve • EVAP canister • Rubber hose from EVAP canister vent control valve to vehicle frame

DTC CONFIRMATION PROCEDURE

1. PRECONDITIONING

If DTC Confirmation Procedure has been previously conducted, always perform the following before conducting the next test.

1. Turn ignition switch OFF and wait at least 10 seconds.
2. Turn ignition switch ON.
3. Turn ignition switch OFF and wait at least 10 seconds.

TESTING CONDITION:

Always perform test at a temperature of 5°C (41°F) or more.

>> GO TO 2.

2. PERFORM DTC CONFIRMATION PROCEDURE

With CONSULT-III

1. Start engine and warm it up to normal operating temperature.
2. Turn ignition switch OFF and wait at least 10 seconds.
3. Turn ignition switch ON.
4. Turn ignition switch OFF and wait at least 10 seconds.
5. Turn ignition switch ON.
6. Select "DATA MONITOR" mode with CONSULT-III.
7. Check that "FUEL T/TMP SE" is more than 0°C (32°F).
8. Start engine and wait at least 20 seconds.
9. Check 1st trip DTC.

P0453 EVAP CONTROL SYSTEM PRESSURE SENSOR

[VQ35DE]

< COMPONENT DIAGNOSIS >

With GST

1. Start engine and warm it up to normal operating temperature.
2. Set voltmeter probes to ECM harness connector terminals.

ECM		
Connector	+	-
	Terminal	Terminal
E16	95 (Fuel tank temperature sensor signal)	104 (Sensor ground)

3. Check that the voltage is less than 4.2 V.
4. Turn ignition switch OFF and wait at least 10 seconds.
5. Turn ignition switch ON.
6. Turn ignition switch OFF and wait at least 10 seconds.
7. Start engine and wait at least 20 seconds.
8. Check 1st trip DTC.

Is 1st trip DTC detected?

- YES >> Go to [EC-309, "Diagnosis Procedure"](#).
NO >> INSPECTION END

Diagnosis Procedure

INFOID:000000003388081

1. CHECK GROUND CONNECTION

1. Turn ignition switch OFF.
2. Check ground connection E38. Refer to Ground Inspection in [GI-43, "Circuit Inspection"](#).

Is the inspection result normal?

- YES >> GO TO 2.
NO >> Repair or replace ground connection.

2. CHECK CONNECTOR

1. Disconnect EVAP control system pressure sensor harness connector.
2. Check that water is not inside connectors.

Is the inspection result normal?

- YES >> GO TO 3.
NO >> Repair or replace harness connector.

3. CHECK EVAP CONTROL SYSTEM PRESSURE SENSOR POWER SUPPLY CIRCUIT

1. Turn ignition switch ON.
2. Check the voltage between EVAP control system pressure sensor harness connector and ground.

EVAP control system pressure sensor		Ground	Voltage (V)
Connector	Terminal		
B17	3	Ground	Approx. 5

Is the inspection result normal?

- YES >> GO TO 10.
NO >> GO TO 4.

4. CHECK EVAP CONTROL SYSTEM PRESSURE SENSOR POWER SUPPLY CIRCUIT-II

1. Turn ignition switch OFF.
2. Disconnect ECM harness connector.
3. Check the continuity between EVAP control system pressure sensor harness connector and ECM harness connector.

P0453 EVAP CONTROL SYSTEM PRESSURE SENSOR

< COMPONENT DIAGNOSIS >

[VQ35DE]

EVAP control system pressure sensor		ECM		Continuity
Connector	Terminal	Connector	Terminal	
B17	3	E16	91	Existed

Is the inspection result normal?

YES >> GO TO 6.

NO >> GO TO 5.

5.DETECT MALFUNCTIONING PART

Check the following.

- Harness connectors B4, E104
- Harness for open or short between EVAP control system pressure sensor and ECM

>> Repair open circuit.

6.CHECK SENSOR POWER SUPPLY CIRCUIT

Check harness for short to power and short to ground, between the following terminals.

ECM		Sensor		
Connector	Terminal	Name	Connector	Terminal
F8	72	Refrigerant pressure sensor	E300	1
	76	CKP sensor (POS)	F20	1
E16	87	APP sensor	E110	5
	91	EVAP control system pressure sensor	B17	3

Is the inspection result normal?

YES >> GO TO 7.

NO >> Repair short to ground or short to power in harness or connectors.

7.CHECK COMPONENTS

Check the following.

- Crankshaft position sensor (POS) (Refer to [EC-263, "Component Inspection"](#).)
- Refrigerant pressure sensor (Refer to [EC-463, "Diagnosis Procedure"](#).)

Is the inspection result normal?

YES >> GO TO 8.

NO >> Replace malfunctioning components.

8.CHECK APP SENSOR

Refer to [EC-415, "Component Inspection"](#).

Is the inspection result normal?

YES >> GO TO 15.

NO >> GO TO 9.

9.REPLACE ACCELERATOR PEDAL ASSEMBLY

1. Replace accelerator pedal assembly.
2. Refer to [EC-415, "Special Repair Requirement"](#).

>> INSPECTION END

10.CHECK EVAP CONTROL SYSTEM PRESSURE SENSOR GROUND CIRCUIT FOR OPEN AND SHORT

1. Turn ignition switch OFF.
2. Disconnect ECM harness connector.
3. Check the continuity between EVAP control system pressure sensor harness connector and ECM harness connector.

P0453 EVAP CONTROL SYSTEM PRESSURE SENSOR

< COMPONENT DIAGNOSIS >

[VQ35DE]

EVAP control system pressure sensor		ECM		Continuity
Connector	Terminal	Connector	Terminal	
B17	1	E16	96	Existed

4. Also check harness for short to ground and short to power.

Is the inspection result normal?

- YES >> GO TO 12.
- NO >> GO TO 11.

11.DETECT MALFUNCTIONING PART

Check the following.

- Harness connectors B4, E104
- Harness for open or short between EVAP control system pressure sensor and ECM

>> Repair open circuit, short to ground or short to power in harness or connectors.

12.CHECK EVAP CONTROL SYSTEM PRESSURE SENSOR INPUT SIGNAL CIRCUIT FOR OPEN AND SHORT

1. Check the continuity between EVAP control system pressure sensor harness connector and ECM harness connector.

EVAP control system pressure sensor		ECM		Continuity
Connector	Terminal	Connector	Terminal	
B17	2	E16	86	Existed

2. Also check harness for short to ground and short to power.

Is the inspection result normal?

- YES >> GO TO 14.
- NO >> GO TO 13.

13.DETECT MALFUNCTIONING PART

Check the following.

- Harness connectors B4, E104
- Harness for open or short between EVAP control system pressure sensor and ECM

>> Repair open circuit, short to ground or short to power in harness or connectors.

14.CHECK RUBBER TUBE

1. Disconnect rubber tube connected to EVAP canister vent control valve.
2. Check the rubber tube for clogging.

Is the inspection result normal?

- YES >> GO TO 15.
- NO >> Clean the rubber tube using an air blower, repair or replace rubber tube.

15.CHECK EVAP CANISTER VENT CONTROL VALVE

Refer to [EC-294. "Component Inspection"](#).

Is the inspection result normal?

- YES >> GO TO 16.
- NO >> Replace EVAP canister vent control valve.

16.CHECK EVAP CONTROL SYSTEM PRESSURE SENSOR

Refer to [EC-312. "Component Inspection"](#).

Is the inspection result normal?

- YES >> GO TO 17.
- NO >> Replace EVAP control system pressure sensor.

P0453 EVAP CONTROL SYSTEM PRESSURE SENSOR

[VQ35DE]

< COMPONENT DIAGNOSIS >

17. CHECK IF EVAP CANISTER IS SATURATED WITH WATER

1. Remove EVAP canister with EVAP canister vent control valve and EVAP control system pressure sensor attached.
2. Check if water will drain from the EVAP canister.

Does water drain from the EVAP canister?

- YES >> GO TO 18.
NO >> GO TO 20.

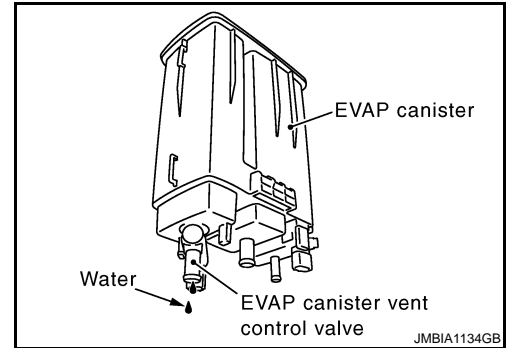

18. CHECK EVAP CANISTER

Weigh the EVAP canister with the EVAP canister vent control valve and EVAP control system pressure sensor attached.

The weight should be less than 2.1 kg (4.6 lb).

Is the inspection result normal?

- YES >> GO TO 20.
NO >> GO TO 19.

19. DETECT MALFUNCTIONING PART

Check the following.

- EVAP canister for damage
- EVAP hose between EVAP canister and vehicle frame for clogging or poor connection

>> Repair hose or replace EVAP canister.

20. CHECK INTERMITTENT INCIDENT

Refer to [GI-40, "Intermittent Incident"](#).

>> INSPECTION END

Component Inspection

INFOID:000000003625711

1. CHECK EVAP CONTROL SYSTEM PRESSURE SENSOR

1. Turn ignition switch OFF.
2. Remove EVAP control system pressure sensor with its harness connector.
Always replace O-ring with a new one.
3. Install a vacuum pump to EVAP control system pressure sensor.
4. Turn ignition switch ON and check output voltage between ECM terminals under the following conditions.

Connector	ECM		Applied vacuum kPa (kg/cm ² , psi)	Voltage
	+	-		
	Terminal	Terminal		
E16	86 (EVAP control system pressure sensor signal)	96 (Sensor ground)	Not applied	1.8 - 4.8 V
			-26.7 (-0.272, -3.87)	2.1 to 2.5 V lower than above value

CAUTION:

- Always calibrate the vacuum pump gauge when using it.
- Never apply below -93.3 kPa (-0.952 kg/cm², -13.53 psi) or pressure over 101.3 kPa (1.033 kg/cm², 14.69 psi).

Is the inspection result normal?

P0453 EVAP CONTROL SYSTEM PRESSURE SENSOR

< COMPONENT DIAGNOSIS >

[VQ35DE]

YES >> INSPECTION END
NO >> Replace EVAP control system pressure sensor

A

EC

C

D

E

F

G

H

I

J

K

L

M

N

O

P

P0455 EVAP CONTROL SYSTEM

< COMPONENT DIAGNOSIS >

[VQ35DE]

P0455 EVAP CONTROL SYSTEM

DTC Logic

INFOID:000000003388083

DTC DETECTION LOGIC

This diagnosis detects a very large leakage (fuel filler cap fell off etc.) in EVAP system between the fuel tank and EVAP canister purge volume control solenoid valve.

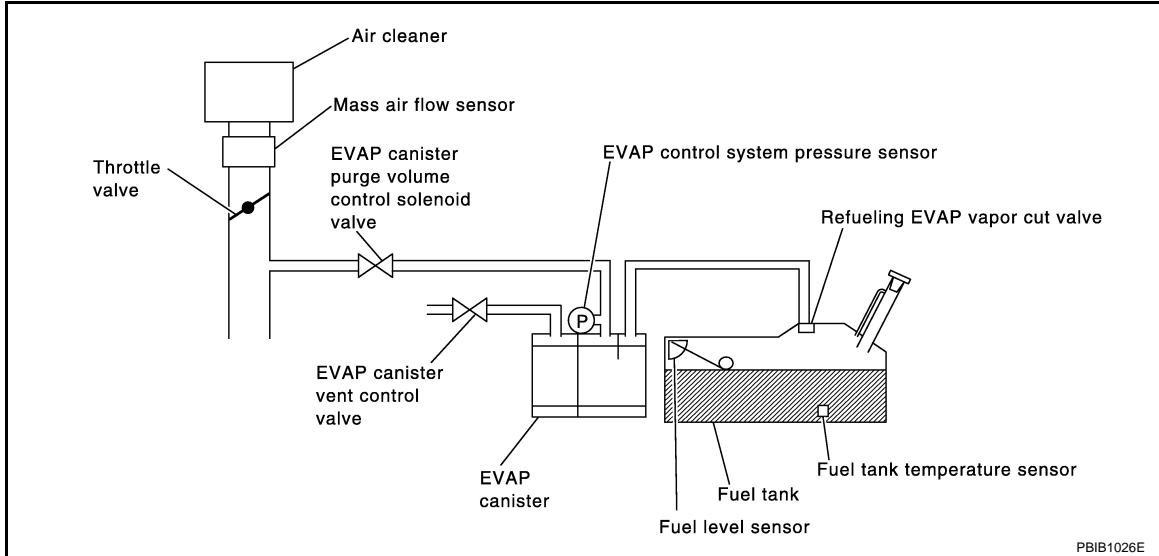

DTC No.	Trouble diagnosis name	DTC detecting condition	Possible cause
P0455	EVAP control system gross leakage detected	EVAP control system has a very large leakage such as fuel filler cap fell off, EVAP control system does not operate properly.	<ul style="list-style-type: none"> Fuel filler cap remains open or does not close. Incorrect fuel tank vacuum relief valve Incorrect fuel filler cap used Foreign matter caught in fuel filler cap. Leakage is in line between intake manifold and EVAP canister purge volume control solenoid valve. Foreign matter caught in EVAP canister vent control valve. EVAP canister or fuel tank leakage EVAP purge line (pipe and rubber tube) leakage EVAP purge line rubber tube bent. Loose or disconnected rubber tube EVAP canister vent control valve and the circuit EVAP canister purge volume control solenoid valve and the circuit Fuel tank temperature sensor O-ring of EVAP canister vent control valve is missing or damaged. EVAP control system pressure sensor Refueling EVAP vapor cut valve ORVR system leakage

CAUTION:

- Use only a genuine NISSAN fuel filler cap as a replacement. If an incorrect fuel filler cap is used, the MIL may illuminate.
- If the fuel filler cap is not tightened properly, the MIL may illuminate.
- Use only a genuine NISSAN rubber tube as a replacement.

DTC CONFIRMATION PROCEDURE

1. PRECONDITIONING

CAUTION:

P0455 EVAP CONTROL SYSTEM

< COMPONENT DIAGNOSIS >

[VQ35DE]

Never remove fuel filler cap during the DTC Confirmation Procedure.

If DTC Confirmation Procedure has been previously conducted, always perform the following before conducting the next test.

1. Turn ignition switch OFF and wait at least 10 seconds.
2. Turn ignition switch ON.
3. Turn ignition switch OFF and wait at least 10 seconds.

Check that EVAP hoses are connected to EVAP canister purge volume control solenoid valve properly.

TESTING CONDITION:

- Perform "DTC WORK SUPPORT" when the fuel level is between 1/4 and 3/4 full, and vehicle is placed on flat level surface.
- Open engine hood before conducting the following procedures.

Will CONSULT-III be used?

- YES >> GO TO 2.
NO >> GO TO 4.

2.PERFORM DTC CONFIRMATION PROCEDURE

 **With CONSULT-III**

1. Tighten fuel filler cap securely until ratcheting sound is heard.
2. Turn ignition switch ON.
3. Turn ignition switch OFF and wait at least 10 seconds.
4. Turn ignition switch ON and select "DATA MONITOR" mode with CONSULT-III.
5. Check that the following conditions are met.
COOLAN TEMP/S: 0 - 70°C (32 - 158°F)
INT/A TEMP SE: 0 - 60°C (32 - 140°F)
6. Select "EVP SML LEAK P0442/P1442" of "EVAPORATIVE SYSTEM" in "DTC WORK SUPPORT" mode with CONSULT-III.

Follow the instructions displayed.

NOTE:

If the engine speed cannot be maintained within the range displayed on the CONSULT-III screen, go to [EC-12. "BASIC INSPECTION : Special Repair Requirement"](#).

Which is displayed on CONSULT-III screen?

- OK >> INSPECTION END
NG >> GO TO 3.

3.CHECK DTC

Check DTC.

Which DTC is detected?

- P0455 >> Go to [EC-316. "Diagnosis Procedure"](#).
P0442 >> Go to [EC-279. "Diagnosis Procedure"](#).

4.PERFORM DTC CONFIRMATION PROCEDURE

 **With GST**

NOTE:

Be sure to read the explanation of DRIVING PATTERN in [EC-524. "How to Set SRT Code"](#) before driving vehicle.

1. Start engine.
2. Drive vehicle according to DRIVING PATTERN.
3. Stop vehicle.
4. Turn ignition switch OFF and wait at least 10 seconds.
5. Turn ignition switch ON.
6. Turn ignition switch OFF and wait at least 10 seconds.
7. Turn ignition switch ON.
8. Check 1st trip DTC.

Is 1st trip DTC detected?

- YES-1 >> P0455: Go to [EC-316. "Diagnosis Procedure"](#).
YES-2 >> P0442: Go to [EC-279. "Diagnosis Procedure"](#).
YES-3 >> P0441: Go to [EC-275. "Diagnosis Procedure"](#).
NO >> INSPECTION END

P0455 EVAP CONTROL SYSTEM

< COMPONENT DIAGNOSIS >

[VQ35DE]

Diagnosis Procedure

INFOID:000000003388084

1. CHECK FUEL FILLER CAP DESIGN

1. Turn ignition switch OFF.
2. Check for genuine NISSAN fuel filler cap design.

Is the inspection result normal?

- YES >> GO TO 2.
NO >> Replace with genuine NISSAN fuel filler cap.

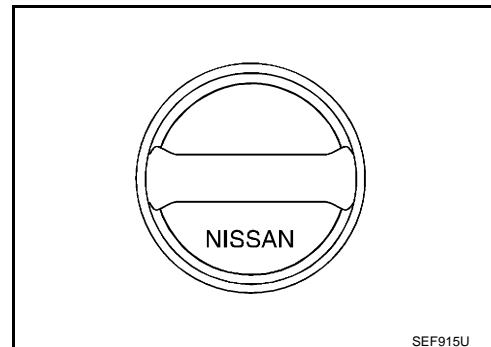

2. CHECK FUEL FILLER CAP INSTALLATION

Check that the cap is tightened properly by rotating the cap clockwise.

Is the inspection result normal?

- YES >> GO TO 3.
NO >> Open fuel filler cap, then clean cap and fuel filler neck threads using air blower. Retighten until ratcheting sound is heard.

3. CHECK FUEL FILLER CAP FUNCTION

Check for air releasing sound while opening the fuel filler cap.

Is the inspection result normal?

- YES >> GO TO 5.
NO >> GO TO 4.

4. CHECK FUEL TANK VACUUM RELIEF VALVE

Refer to [EC-318, "Component Inspection"](#).

Is the inspection result normal?

- YES >> GO TO 5.
NO >> Replace fuel filler cap with a genuine one.

5. CHECK EVAP PURGE LINE

Check EVAP purge line (pipe, rubber tube, fuel tank and EVAP canister) for cracks, improper connection or disconnection.

Refer to [EC-77, "System Diagram"](#).

Is the inspection result normal?

- YES >> GO TO 6.
NO >> Repair or reconnect the hose.

6. CLEAN EVAP PURGE LINE

Clean EVAP purge line (pipe and rubber tube) using air blower.

>> GO TO 7.

7. CHECK EVAP CANISTER VENT CONTROL VALVE

Check the following.

- EVAP canister vent control valve is installed properly.
Refer to [EC-549, "Removal and Installation"](#).
- EVAP canister vent control valve.
Refer to [EC-294, "Component Inspection"](#).

Is the inspection result normal?

- YES >> GO TO 8.
NO >> Repair or replace EVAP canister vent control valve and O-ring.

P0455 EVAP CONTROL SYSTEM

< COMPONENT DIAGNOSIS >

[VQ35DE]

8. CHECK FOR EVAP LEAKAGE

Refer to [EC-547. "Inspection"](#).

Is there any leakage in EVAP line?

- YES >> Repair or replace.
- NO-1 >> With CONSULT-III: GO TO 9.
- NO-2 >> Without CONSULT-III: GO TO 10.

9. CHECK EVAP CANISTER PURGE VOLUME CONTROL SOLENOID VALVE OPERATION

With CONSULT-III

1. Disconnect vacuum hose from EVAP canister purge volume control solenoid valve at EVAP service port.
2. Start engine.
3. Perform "PURG VOL C/V" in "ACTIVE TEST" mode.
4. Touch "Qu" on CONSULT-III screen to increase "PURG VOL C/V" opening to 100%.
5. Check vacuum hose for vacuum.

Vacuum should exist.

Is the inspection result normal?

- YES >> GO TO 12.
- NO >> GO TO 11.

10. CHECK EVAP CANISTER PURGE VOLUME CONTROL SOLENOID VALVE OPERATION

Without CONSULT-III

1. Start engine and warm it up to normal operating temperature.
2. Stop engine.
3. Disconnect vacuum hose from EVAP canister purge volume control solenoid valve at EVAP service port.
4. Start engine and let it idle for at least 80 seconds.
5. Check vacuum hose for vacuum when revving engine up to 2,000 rpm.

Vacuum should exist.

Is the inspection result normal?

- YES >> GO TO 13.
- NO >> GO TO 11.

11. CHECK VACUUM HOSE

Check vacuum hoses for clogging or disconnection. Refer to [EC-77. "System Diagram"](#).

Is the inspection result normal?

- YES-1 >> With CONSULT-III: GO TO 12.
- YES-2 >> Without CONSULT-III: GO TO 13.
- NO >> Repair or reconnect the hose.

12. CHECK EVAP CANISTER PURGE VOLUME CONTROL SOLENOID VALVE

With CONSULT-III

1. Start engine.
2. Perform "PURG VOL C/V" in "ACTIVE TEST" mode with CONSULT-III. Check that engine speed varies according to the valve opening.

Does engine speed vary according to the valve opening?

- YES >> GO TO 14.
- NO >> GO TO 13.

13. CHECK EVAP CANISTER PURGE VOLUME CONTROL SOLENOID VALVE

Refer to [EC-287. "Component Inspection"](#).

Is the inspection result normal?

- YES >> GO TO 14.
- NO >> Replace EVAP canister purge volume control solenoid valve.

14. CHECK FUEL TANK TEMPERATURE SENSOR

P0455 EVAP CONTROL SYSTEM

[VQ35DE]

< COMPONENT DIAGNOSIS >

Refer to [EC-238, "Component Inspection"](#).

Is the inspection result normal?

YES >> GO TO 15.

NO >> Replace fuel level sensor unit.

15. CHECK EVAP CONTROL SYSTEM PRESSURE SENSOR

Refer to [EC-302, "Component Inspection"](#).

Is the inspection result normal?

YES >> GO TO 16.

NO >> Replace EVAP control system pressure sensor.

16. CHECK EVAP/ORVR LINE

Check EVAP/ORVR line between EVAP canister and fuel tank for clogging, kinks, looseness and improper connection. For location, refer to [EC-457, "Description"](#).

Is the inspection result normal?

YES >> GO TO 17.

NO >> Repair or replace hoses and tubes.

17. CHECK RECIRCULATION LINE

Check recirculation line between filler neck tube and fuel tank for clogging, kinks, cracks, looseness and improper connection.

Is the inspection result normal?

YES >> GO TO 18.

NO >> Repair or replace hose, tube or filler neck tube.

18. CHECK REFUELING EVAP VAPOR CUT VALVE

Refer to [EC-460, "Component Inspection"](#).

Is the inspection result normal?

YES >> GO TO 19.

NO >> Replace refueling EVAP vapor cut valve with fuel tank.

19. CHECK INTERMITTENT INCIDENT

Refer to [GI-40, "Intermittent Incident"](#).

>> INSPECTION END

Component Inspection

INFOID:000000003591639

1. CHECK FUEL FILLER CAP

1. Turn ignition switch OFF.
2. Remove fuel filler cap.
3. Wipe clean valve housing.

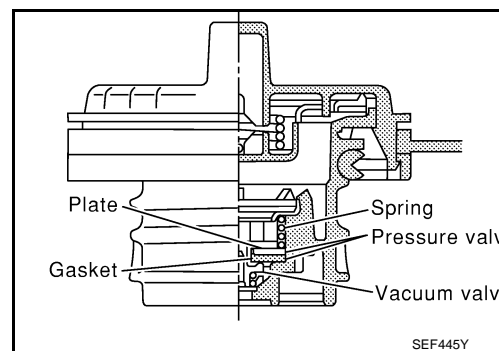

4. Install fuel filler cap adapter (commercial service tool) to fuel filler cap.

P0455 EVAP CONTROL SYSTEM

[VQ35DE]

< COMPONENT DIAGNOSIS >

5. Check valve opening pressure and vacuum.

Pressure: 15.3 - 20.0 kPa (0.156 - 0.204 kg/cm², 2.22 - 2.90 psi)

Vacuum: -6.0 to -3.3 kPa (-0.061 to -0.034 kg/cm², -0.87 to -0.48 psi)

Is the inspection result normal?

YES >> INSPECTION END

NO >> GO TO 2.

2. REPLACE FUEL FILLER CAP

Replace fuel filler cap.

CAUTION:

Use only a genuine fuel filler cap as a replacement. If an incorrect fuel filler cap is used, the MIL may illuminate.

>> INSPECTION END

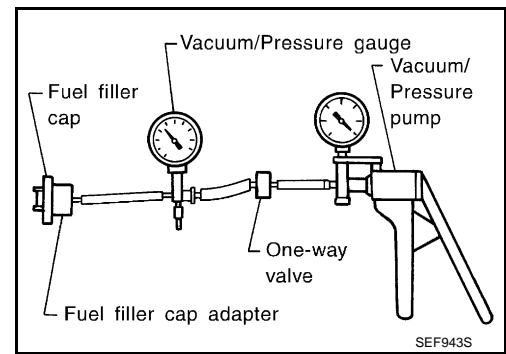

A

EC

C

D

E

F

G

H

I

J

K

L

M

N

O

P

P0456 EVAP CONTROL SYSTEM

< COMPONENT DIAGNOSIS >

[VQ35DE]

P0456 EVAP CONTROL SYSTEM

DTC Logic

INFOID:000000003388086

DTC DETECTION LOGIC

NOTE:

If DTC P0456 is displayed with DTC P0442, first perform the trouble diagnosis for DTC P0456.

This diagnosis detects very small leakage in the EVAP line between fuel tank and EVAP canister purge volume control solenoid valve, using the negative pressure.

If ECM judges a leakage which corresponds to a very small leakage, the very small leakage P0456 will be detected.

If ECM judges a leakage equivalent to a small leakage, EVAP small leakage P0442 will be detected.

If ECM judges that there are no leakage, the diagnosis will be OK.

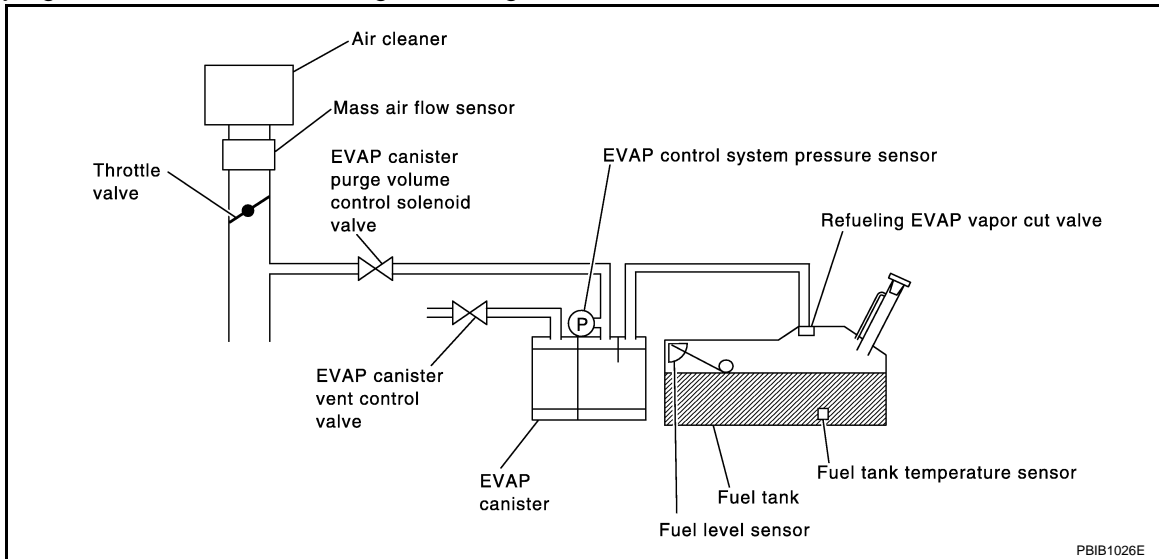

DTC No.	Trouble diagnosis name	DTC detecting condition	Possible cause
P0456	Evaporative emission control system very small leakage (negative pressure check)	<ul style="list-style-type: none"> • EVAP system has a very small leakage. • EVAP system does not operate properly. 	<ul style="list-style-type: none"> • Incorrect fuel tank vacuum relief valve • Incorrect fuel filler cap used • Fuel filler cap remains open or does not close. • Foreign matter caught in fuel filler cap. • Leakage is in line between intake manifold and EVAP canister purge volume control solenoid valve. • Foreign matter caught in EVAP canister vent control valve. • EVAP canister or fuel tank leakage • EVAP purge line (pipe and rubber tube) leakage • EVAP purge line rubber tube bent • Loose or disconnected rubber tube • EVAP canister vent control valve and the circuit • EVAP canister purge volume control solenoid valve and the circuit • Fuel tank temperature sensor • O-ring of EVAP canister vent control valve is missing or damaged • EVAP canister is saturated with water • EVAP control system pressure sensor • Refueling EVAP vapor cut valve • ORVR system leakage • Fuel level sensor and the circuit • Foreign matter caught in EVAP canister purge volume control solenoid valve

CAUTION:

P0456 EVAP CONTROL SYSTEM

< COMPONENT DIAGNOSIS >

[VQ35DE]

- Use only a genuine NISSAN fuel filler cap as a replacement. If an incorrect fuel filler cap is used, the MIL may illuminate.
- If the fuel filler cap is not tightened properly, the MIL may illuminate.
- Use only a genuine NISSAN rubber tube as a replacement.

DTC CONFIRMATION PROCEDURE

1. PRECONDITIONING

If DTC Confirmation Procedure has been previously conducted, always perform the following before conducting the next test.

1. Turn ignition switch OFF and wait at least 10 seconds.
2. Turn ignition switch ON.
3. Turn ignition switch OFF and wait at least 10 seconds.

Will CONSULT-III be used?

- YES >> GO TO 2.
- NO >> GO TO 4.

2. PRECONDITIONING

If DTC CONFIRMATION PROCEDURE has been previously conducted, always turn ignition switch OFF and wait at least 10 seconds before conducting the next test.

NOTE:

- After repair, make sure that the hoses and clips are installed properly.
- Check that EVAP hoses are connected to EVAP canister purge volume control solenoid valve properly.

TESTING CONDITION:

- Open engine hood before conducting the following procedure.
- If any of following conditions are met just before the DTC CONFIRMATION PROCEDURE, leave the vehicle for more than 1 hour.
 - Fuel filler cap is removed.
 - Fuel is refilled or drained.
 - EVAP component part/parts is/are removed.
- Before performing the following procedure, confirm that battery voltage is more than 11 V at idle.

>> GO TO 3.

3. PERFORM DTC CONFIRMATION PROCEDURE

Ⓜ With CONSULT-III

1. Turn ignition switch ON and select "DATA MONITOR" mode with CONSULT-III.
2. Check that the following conditions are met.
 - FUEL LEVEL SE: 0.25 - 1.4 V**
 - COOLAN TEMP/S: 0 - 32°C (32 - 90°F)**
 - FUEL T/TMP SE: 0 - 35°C (32 - 95°F)**
 - INT A/TEMP SE: More than 0°C (32°F)**If NG, turn ignition switch OFF and leave the vehicle in a cool place (soak the vehicle), or refill/drain fuel until the output voltage of the "FUEL LEVEL SE" meets within the range above and leave the vehicle for more than 1 hour. Then start from step 1.
3. Turn ignition switch OFF and wait at least 10 seconds.
4. Turn ignition switch ON.
5. Select "EVP V/S LEAK P0456/P1456" of "EVAPORATIVE SYSTEM" in "DTC WORK SUPPORT" mode with CONSULT-III.

Follow the instructions displayed.

NOTE:

If the engine speed cannot be maintained within the range displayed on CONSULT-III screen, go to [EC-12. "BASIC INSPECTION : Special Repair Requirement"](#).

Which is displayed on CONSULT-III?

- OK >> INSPECTION END
- NG >> Go to [EC-322. "Diagnosis Procedure"](#).

4. PERFORM COMPONENT FUNCTION CHECK

Perform Component Function Check. Refer to [EC-322. "Component Function Check"](#).

P0456 EVAP CONTROL SYSTEM

< COMPONENT DIAGNOSIS >

[VQ35DE]

NOTE:

Use Component Function Check to check the overall function of the EVAP very small leakage function. During this check, a 1st trip DTC might not be confirmed.

Is the inspection result normal?

YES >> INSPECTION END

NO >> Go to [EC-322, "Diagnosis Procedure"](#).

Component Function Check

INFOID:000000003733525

1. PERFORM COMPONENT FUNCTION CHECK

 With GST

CAUTION:

- Never use compressed air, doing so may damage the EVAP system.
- Never start engine.
- Never exceed 4.12 kPa (0.042 kg/cm², 0.6 psi).

1. Attach the EVAP service port adapter (commercial service tool) securely to the EVAP service port.
2. Set the pressure pump and a hose.
3. Also set a vacuum gauge via 3-way connector and a hose.
4. Turn ignition switch ON.
5. Connect GST and select Service \$08.
6. Using Service \$08 control the EVAP canister vent control valve (close).
7. Apply pressure and make sure the following conditions are satisfied.

Pressure to be applied: 2.7 kPa (0.028 kg/cm², 0.39 psi)

Time to be waited after the pressure drawn in to the EVAP system and the pressure to be dropped: 60 seconds and the pressure should not be dropped more than 0.4 kPa (0.004 kg/cm², 0.06 psi).

Is the inspection result normal?

YES >> GO TO 2.

NO >> Go to [EC-322, "Diagnosis Procedure"](#).

2. RELEASE PRESSURE

1. Disconnect GST.
2. Start engine and warm it up to normal operating temperature.
3. Turn ignition switch OFF and wait at least 10 seconds.
4. Restart engine and let it idle for 90 seconds.
5. Keep engine speed at 2,000 rpm for 30 seconds.
6. Turn ignition switch OFF.

NOTE:

For more information, refer to GST Instruction Manual.

>> INSPECTION END

Diagnosis Procedure

INFOID:000000003388088

1. CHECK FUEL FILLER CAP DESIGN

1. Turn ignition switch OFF.

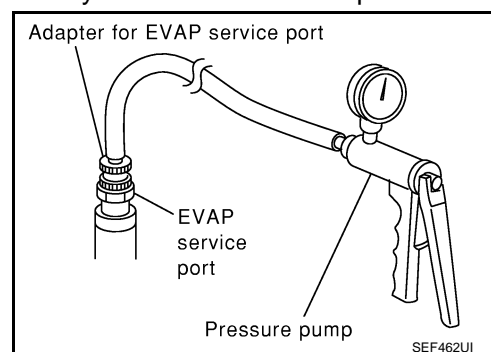

P0456 EVAP CONTROL SYSTEM

[VQ35DE]

< COMPONENT DIAGNOSIS >

2. Check for genuine NISSAN fuel filler cap design.

Is the inspection result normal?

YES >> GO TO 2.

NO >> Replace with genuine NISSAN fuel filler cap.

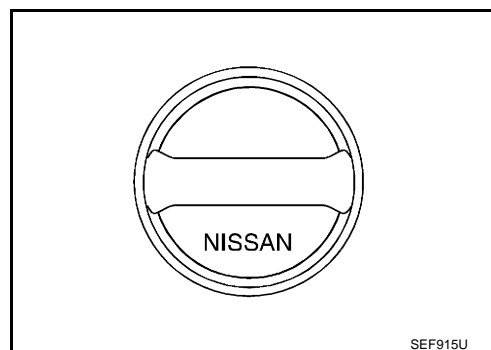

2.CHECK FUEL FILLER CAP INSTALLATION

Check that the cap is tightened properly by rotating the cap clockwise.

Is the inspection result normal?

YES >> GO TO 3.

NO >> Open fuel filler cap, then clean cap and fuel filler neck threads using air blower. Retighten until ratcheting sound is heard.

3.CHECK FUEL FILLER CAP FUNCTION

Check for air releasing sound while opening the fuel filler cap.

Is the inspection result normal?

YES >> GO TO 5.

NO >> GO TO 4.

4.CHECK FUEL TANK VACUUM RELIEF VALVE

Refer to [EC-326. "Component Inspection"](#).

Is the inspection result normal?

YES >> GO TO 5.

NO >> Replace fuel filler cap with a genuine one.

5.CHECK FOR EVAP LEAKAGE

Refer to [EC-547. "Inspection"](#).

Is there any leakage in EVAP line?

YES >> Repair or replace malfunctioning part.

NO >> GO TO 6.

6.CHECK EVAP CANISTER VENT CONTROL VALVE

Check the following.

- EVAP canister vent control valve is installed properly.

Refer to [EC-549. "Removal and Installation"](#).

- EVAP canister vent control valve.

Refer to [EC-294. "Component Inspection"](#).

Is the inspection result normal?

YES >> GO TO 7.

NO >> Repair or replace EVAP canister vent control valve and O-ring.

7.CHECK IF EVAP CANISTER IS SATURATED WITH WATER

P0456 EVAP CONTROL SYSTEM

[VQ35DE]

< COMPONENT DIAGNOSIS >

Remove EVAP canister with EVAP canister vent control valve and EVAP control system pressure sensor attached.

Does water drain from the EVAP canister?

- YES >> GO TO 8.
- NO-1 >> With CONSULT-III: GO TO 10.
- NO-2 >> Without CONSULT-III: GO TO 11.

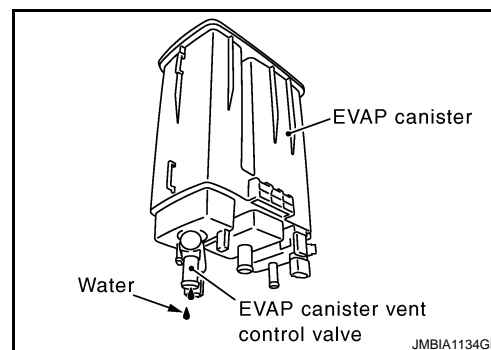

8. CHECK EVAP CANISTER

Weigh the EVAP canister with the EVAP canister vent control valve and EVAP control system pressure sensor attached.

The weight should be less than 2.1 kg (4.6 lb).

Is the inspection result normal?

- YES-1 >> With CONSULT-III: GO TO 10.
- YES-2 >> Without CONSULT-III: GO TO 11.
- NO >> GO TO 9.

9. DETECT MALFUNCTIONING PART

Check the following.

- EVAP canister for damage
- EVAP hose between EVAP canister and vehicle frame for clogging or poor connection

>> Repair hose or replace EVAP canister.

10. CHECK EVAP CANISTER PURGE VOLUME CONTROL SOLENOID VALVE OPERATION

With CONSULT-III

1. Disconnect vacuum hose connected to EVAP service port and EVAP canister purge volume control solenoid valve from EVAP service port.
2. Start engine.
3. Perform "PURG VOL C/V" in "ACTIVE TEST" mode.
4. Touch "Qu" on CONSULT-III screen to increase "PURG VOL C/V" opening to 100%.
5. Check vacuum hose for vacuum.

Vacuum should exist.

Is the inspection result normal?

- YES >> GO TO 13.
- NO >> GO TO 12.

11. CHECK EVAP CANISTER PURGE VOLUME CONTROL SOLENOID VALVE OPERATION

Without CONSULT-III

1. Start engine and warm it up to normal operating temperature.
2. Stop engine.
3. Disconnect vacuum hose connected to EVAP service port and EVAP canister purge volume control solenoid valve from EVAP service port.
4. Start engine and let it idle for at least 80 seconds.
5. Check vacuum hose for vacuum when revving engine up to 2,000 rpm.

Vacuum should exist.

Is the inspection result normal?

- YES >> GO TO 14.
- NO >> GO TO 12.

12. CHECK VACUUM HOSE

Check vacuum hoses for clogging or disconnection. Refer to [EC-77, "System Diagram"](#).

P0456 EVAP CONTROL SYSTEM

[VQ35DE]

< COMPONENT DIAGNOSIS >

Is the inspection result normal?

YES >> GO TO 13.

NO >> Repair or reconnect the hose.

13.CHECK EVAP CANISTER PURGE VOLUME CONTROL SOLENOID VALVE

Refer to [EC-287, "Component Inspection"](#).

Is the inspection result normal?

YES >> GO TO 14.

NO >> Replace EVAP canister purge volume control solenoid valve.

14.CHECK FUEL TANK TEMPERATURE SENSOR

Refer to [EC-238, "Component Inspection"](#).

Is the inspection result normal?

YES >> GO TO 15.

NO >> Replace fuel level sensor unit.

15.CHECK EVAP CONTROL SYSTEM PRESSURE SENSOR

Refer to [EC-302, "Component Inspection"](#).

Is the inspection result normal?

YES >> GO TO 16.

NO >> Replace EVAP control system pressure sensor.

16.CHECK EVAP PURGE LINE

Check EVAP purge line (pipe, rubber tube, fuel tank and EVAP canister) for cracks or improper connection.

Refer to [EC-77, "System Diagram"](#).

Is the inspection result normal?

YES >> GO TO 17.

NO >> Repair or reconnect the hose.

17.CLEAN EVAP PURGE LINE

Clean EVAP purge line (pipe and rubber tube) using air blower.

>> GO TO 18.

18.CHECK EVAP/ORVR LINE

Check EVAP/ORVR line between EVAP canister and fuel tank for clogging, kinks, looseness and improper connection. For location, refer to [EC-457, "Description"](#).

Is the inspection result normal?

YES >> GO TO 19.

NO >> Repair or replace hoses and tubes.

19.CHECK RECIRCULATION LINE

Check recirculation line between filler neck tube and fuel tank for clogging, kinks, cracks, looseness and improper connection.

Is the inspection result normal?

YES >> GO TO 20.

NO >> Repair or replace hose, tube or filler neck tube.

20.CHECK REFUELING EVAP VAPOR CUT VALVE

Refer to [EC-460, "Component Inspection"](#).

Is the inspection result normal?

YES >> GO TO 21.

NO >> Replace refueling EVAP vapor cut valve with fuel tank.

21.CHECK FUEL LEVEL SENSOR

Refer to [MWI-47, "Component Inspection"](#).

Is the inspection result normal?

A

EC

C

D

E

F

G

H

I

J

K

L

M

N

O

P

P0456 EVAP CONTROL SYSTEM

[VQ35DE]

< COMPONENT DIAGNOSIS >

- YES >> GO TO 22.
- NO >> Replace fuel level sensor unit.

22.CHECK INTERMITTENT INCIDENT

Refer to [GI-40. "Intermittent Incident"](#).

>> INSPECTION END

Component Inspection

INFOID:000000003591640

1.CHECK FUEL FILLER CAP

1. Turn ignition switch OFF.
2. Remove fuel filler cap.
3. Wipe clean valve housing.

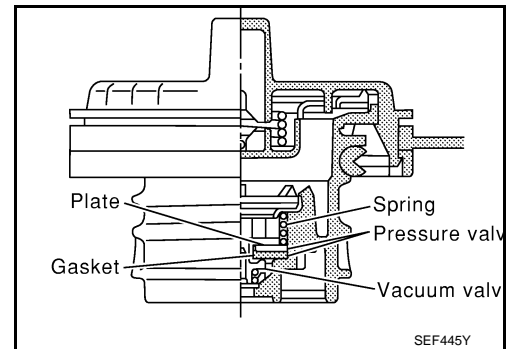

4. Install fuel filler cap adapter (commercial service tool) to fuel filler cap.
5. Check valve opening pressure and vacuum.

Pressure: 15.3 - 20.0 kPa (0.156 - 0.204 kg/cm², 2.22 - 2.90 psi)

Vacuum: -6.0 to -3.3 kPa (-0.061 to -0.034 kg/cm², -0.87 to -0.48 psi)

Is the inspection result normal?

- YES >> INSPECTION END
- NO >> GO TO 2.

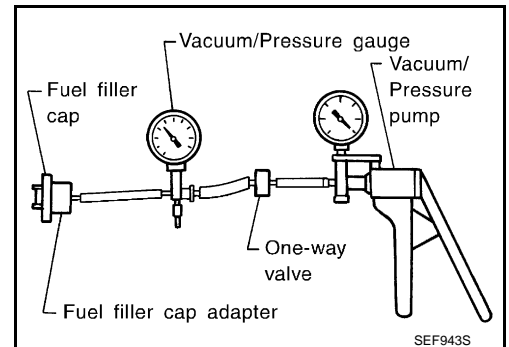

2.REPLACE FUEL FILLER CAP

Replace fuel filler cap.

CAUTION:

Use only a genuine fuel filler cap as a replacement. If an incorrect fuel filler cap is used, the MIL may illuminate.

>> INSPECTION END

P0460 FUEL LEVEL SENSOR

< COMPONENT DIAGNOSIS >

[VQ35DE]

P0460 FUEL LEVEL SENSOR

Description

INFOID:000000003388090

The fuel level sensor is mounted in the fuel level sensor unit.
 The sensor detects a fuel level in the fuel tank and transmits a signal to the combination meter. The combination meter sends the fuel level sensor signal to the ECM via the CAN communication line.
 It consists of two parts, one is mechanical float and the other is variable resistor. Fuel level sensor output voltage changes depending on the movement of the fuel mechanical float.

DTC Logic

INFOID:000000003388091

DTC DETECTION LOGIC

NOTE:

- If DTC P0460 is displayed with DTC UXXXX, first perform the trouble diagnosis for DTC UXXXX.
- If DTC P0460 is displayed with DTC P0607, first perform the trouble diagnosis for DTC P0607. Refer to [EC-346, "DTC Logic"](#).

When the vehicle is parked, the fuel level in the fuel tank is naturally stable. It means that output signal of the fuel level sensor does not change. If ECM senses sloshing signal from the sensor, fuel level sensor malfunction is detected.

DTC No.	Trouble diagnosis name	DTC detecting condition	Possible cause
P0460	Fuel level sensor circuit noise	Even though the vehicle is parked, a signal being varied is sent from the fuel level sensor to ECM.	<ul style="list-style-type: none"> • Harness or connectors (The CAN communication line is open or shorted) • Harness or connectors (The sensor circuit is open or shorted) • Combination meter • Fuel level sensor

DTC CONFIRMATION PROCEDURE

1. PRECONDITIONING

If DTC Confirmation Procedure has been previously conducted, always perform the following before conducting the next test.

1. Turn ignition switch OFF and wait at least 10 seconds.
2. Turn ignition switch ON.
3. Turn ignition switch OFF and wait at least 10 seconds.

>> GO TO 2.

2. PERFORM DTC CONFIRMATION PROCEDURE

1. Start engine and wait maximum of 2 consecutive minutes.
2. Check 1st trip DTC.

Is 1st trip DTC detected?

- YES >> Go to [EC-327, "Diagnosis Procedure"](#).
 NO >> INSPECTION END

Diagnosis Procedure

INFOID:000000003388092

1. CHECK COMBINATION METER FUNCTION

Refer to [MWI-34, "CONSULT-III Function \(METER/M&A\)"](#).

Is the inspection result normal?

- YES >> GO TO 2.
 NO >> Go to [MWI-46, "Diagnosis Procedure"](#).

2. CHECK INTERMITTENT INCIDENT

Refer to [GI-40, "Intermittent Incident"](#).

P0460 FUEL LEVEL SENSOR

< COMPONENT DIAGNOSIS >

[VQ35DE]

>> INSPECTION END

P0461 FUEL LEVEL SENSOR

< COMPONENT DIAGNOSIS >

[VQ35DE]

P0461 FUEL LEVEL SENSOR

Description

INFOID:000000003591659

The fuel level sensor is mounted in the fuel level sensor unit. The sensor detects a fuel level in the fuel tank and transmits a signal to the combination meter. The combination meter sends the fuel level sensor signal to the ECM via the CAN communication line. It consists of two parts, one is mechanical float and the other is variable resistor. Fuel level sensor output voltage changes depending on the movement of the fuel mechanical float.

DTC Logic

INFOID:000000003388094

DTC DETECTION LOGIC

NOTE:

- If DTC P0461 is displayed with DTC UXXXX, first perform the trouble diagnosis for DTC UXXXX.
- If DTC P0461 is displayed with DTC P0607, first perform the trouble diagnosis for DTC P0607. Refer to [EC-346, "DTC Logic"](#).

Driving long distances naturally affect fuel gauge level.

This diagnosis detects the fuel gauge malfunction of the gauge not moving even after a long distance has been driven.

DTC No.	Trouble diagnosis name	DTC detecting condition	Possible cause
P0461	Fuel level sensor circuit range/performance	The output signal of the fuel level sensor does not change within the specified range even though the vehicle has been driven a long distance.	<ul style="list-style-type: none">• Harness or connectors (The CAN communication line is open or shorted)• Harness or connectors (The sensor circuit is open or shorted)• Combination meter• Fuel level sensor

DTC CONFIRMATION PROCEDURE

1. PERFORM COMPONENT FUNCTION CHECK

Perform component function check. Refer to [EC-329, "Component Function Check"](#).

Use component function check to check the overall function of the fuel level sensor. During this check, a 1st trip DTC might not be confirmed.

Is the inspection result normal?

YES >> INSPECTION END

NO >> Go to [EC-330, "Diagnosis Procedure"](#).

Component Function Check

INFOID:000000003388095

1. PRECONDITIONING

WARNING:

When performing the following procedure, always observe the handling of the fuel. Refer to [FL-12, "Removal and Installation"](#).

TESTING CONDITION:

Before starting component function check, preparation of draining fuel and refilling fuel is required.

Will CONSULT-III be used?

YES >> GO TO 2.

NO >> GO TO 3.

2. PERFORM COMPONENT FUNCTION CHECK

With CONSULT-III

NOTE:

Start from step 10, if it is possible to confirm that the fuel cannot be drained by 30 ℓ (7-7/8 US gal, 6-5/8 Imp gal) in advance.

1. Prepare a fuel container and a spare hose.

P0461 FUEL LEVEL SENSOR

[VQ35DE]

< COMPONENT DIAGNOSIS >

2. Release fuel pressure from fuel line, refer to [EC-547, "Inspection"](#).
3. Remove the fuel feed hose on the fuel level sensor unit.
4. Connect a spare fuel hose where the fuel feed hose was removed.
5. Turn ignition switch OFF and wait at least 10 seconds then turn ON.
6. Select "FUEL LEVEL SE" in "DATA MONITOR" mode with CONSULT-III.
7. Check "FUEL LEVEL SE" output voltage and note it.
8. Select "FUEL PUMP RELAY" in "ACTIVE TEST" mode with CONSULT-III.
9. Touch "ON" and drain fuel approximately 30 ℓ (7-7/8 US gal, 6-5/8 Imp gal) and stop it.
10. Check "FUEL LEVEL SE" output voltage and note it.
11. Fill fuel into the fuel tank for 30 ℓ (7-7/8 US gal, 6-5/8 Imp gal).
12. Check "FUEL LEVEL SE" output voltage and note it.
13. Confirm whether the voltage changes more than 0.03 V during step 7 to 10 and 10 to 12.

Is the inspection result normal?

YES >> INSPECTION END

NO >> Go to [EC-330, "Diagnosis Procedure"](#).

3.PERFORM COMPONENT FUNCTION CHECK

⊗ Without CONSULT-III

NOTE:

Start from step 8, if it is possible to confirm that the fuel cannot be drained by 30 ℓ (7-7/8 US gal, 6-5/8 Imp gal) in advance.

1. Prepare a fuel container and a spare hose.
2. Release fuel pressure from fuel line. Refer to [EC-547, "Inspection"](#).
3. Remove the fuel feed hose on the fuel level sensor unit.
4. Connect a spare fuel hose where the fuel feed hose was removed.
5. Turn ignition switch ON.
6. Drain fuel by 30 ℓ (7-7/8 US gal, 6-5/8 Imp gal) from the fuel tank using proper equipment.
7. Confirm that the fuel gauge indication varies.
8. Fill fuel into the fuel tank for 30 ℓ (7-7/8 US gal, 6-5/8 Imp gal).
9. Confirm that the fuel gauge indication varies.

Is the inspection result normal?

YES >> INSPECTION END

NO >> Go to [EC-330, "Diagnosis Procedure"](#).

Diagnosis Procedure

INFOID:000000003591660

1.CHECK COMBINATION METER FUNCTION

Refer to [MWI-34, "CONSULT-III Function \(METER/M&A\)"](#).

Is the inspection result normal?

YES >> GO TO 2.

NO >> Go to [MWI-46, "Diagnosis Procedure"](#).

2.CHECK INTERMITTENT INCIDENT

Refer to [GI-40, "Intermittent Incident"](#).

>> INSPECTION END

P0462, P0463 FUEL LEVEL SENSOR

< COMPONENT DIAGNOSIS >

[VQ35DE]

P0462, P0463 FUEL LEVEL SENSOR

Description

INFOID:000000003591661

The fuel level sensor is mounted in the fuel level sensor unit. The sensor detects a fuel level in the fuel tank and transmits a signal to the combination meter. The combination meter sends the fuel level sensor signal to the ECM via the CAN communication line. It consists of two parts, one is mechanical float and the other is variable resistor. Fuel level sensor output voltage changes depending on the movement of the fuel mechanical float.

DTC Logic

INFOID:000000003388098

DTC DETECTION LOGIC

NOTE:

- If DTC P0462 or P0463 is displayed with DTC UXXXX, first perform the trouble diagnosis for DTC UXXXX.
- If DTC P0462 or P0463 is displayed with DTC P0607, first perform the trouble diagnosis for DTC P0607. Refer to [EC-346, "DTC Logic"](#).

DTC No.	Trouble diagnosis name	DTC detecting condition	Possible cause
P0462	Fuel level sensor circuit low input	An excessively low voltage from the sensor is sent to ECM.	<ul style="list-style-type: none">• Harness or connectors (The CAN communication line is open or shorted)• Harness or connectors (The sensor circuit is open or shorted)• Combination meter• Fuel level sensor
P0463	Fuel level sensor circuit high input	An excessively high voltage from the sensor is sent to ECM.	

DTC CONFIRMATION PROCEDURE

1. PRECONDITIONING

If DTC Confirmation Procedure has been previously conducted, always perform the following before conducting the next test.

1. Turn ignition switch OFF and wait at least 10 seconds.
2. Turn ignition switch ON.
3. Turn ignition switch OFF and wait at least 10 seconds.

TESTING CONDITION:

Before performing the following procedure, confirm that battery voltage is more than 11 V at ignition switch ON.

>> GO TO 2.

2. PERFORM DTC CONFIRMATION PROCEDURE

1. Turn ignition switch ON and wait at least 5 seconds.
2. Check 1st trip DTC.

Is 1st trip DTC detected?

- YES >> Go to [EC-331, "Diagnosis Procedure"](#).
NO >> INSPECTION END

Diagnosis Procedure

INFOID:000000003591662

1. CHECK COMBINATION METER FUNCTION

Refer to [MWI-34, "CONSULT-III Function \(METER/M&A\)"](#).

Is the inspection result normal?

- YES >> GO TO 2.
NO >> Go to [MWI-46, "Diagnosis Procedure"](#).

2. CHECK INTERMITTENT INCIDENT

Refer to [GI-40, "Intermittent Incident"](#).

P0462, P0463 FUEL LEVEL SENSOR

< COMPONENT DIAGNOSIS >

[VQ35DE]

>> INSPECTION END

P0500 VSS

Description

INFOID:000000003388100

The vehicle speed signal is sent to the combination meter from the “ABS actuator and electric unit (control unit)” via the CAN communication line. The combination meter then sends a signal to the ECM via the CAN communication line.

DTC Logic

INFOID:000000003388101

DTC DETECTION LOGIC

NOTE:

- If DTC P0500 is displayed with DTC UXXXX, first perform the trouble diagnosis for DTC UXXXX.
- If DTC P0500 is displayed with DTC P0607, first perform the trouble diagnosis for DTC P0607. Refer to [EC-346, "DTC Logic"](#).

DTC No.	Trouble diagnosis name	DTC detecting condition	Possible cause
P0500	Vehicle speed sensor	The vehicle speed signal sent to ECM is almost 0 km/h (0 MPH) even when vehicle is being driven.	<ul style="list-style-type: none"> • Harness or connectors (The CAN communication line is open or shorted) • Harness or connectors (The vehicle speed signal circuit is open or shorted) • Wheel sensor • Combination meter • ABS actuator and electric unit (control unit)

DTC CONFIRMATION PROCEDURE

1.INSPECTION START

Will CONSULT-III be used?

Will CONSULT-III be used?

YES >> GO TO 2.

NO >> GO TO 5.

2.PRECONDITIONING

If DTC Confirmation Procedure has been previously conducted, always perform the following before conducting the next test.

1. Turn ignition switch OFF and wait at least 10 seconds.
2. Turn ignition switch ON.
3. Turn ignition switch OFF and wait at least 10 seconds.

>> GO TO 3.

3.CHECK VEHICLE SPEED SIGNAL

NOTE:

This procedure may be conducted with the drive wheels lifted in the shop or by driving the vehicle. If a road test is expected to be easier, it is unnecessary to lift the vehicle.

 With CONSULT-III

1. Start engine (VDC switch OFF).
2. Read “VHCL SPEED SE” in “DATA MONITOR” mode with CONSULT-III. The vehicle speed on CONSULT-III should exceed 10 km/h (6 MPH) when rotating wheels with suitable gear position.

Is the inspection result normal?

YES >> GO TO 4.

NO >> Go to [EC-334, "Diagnosis Procedure"](#).

4.PERFORM DTC CONFIRMATION PROCEDURE

1. Select “DATA MONITOR” mode with CONSULT-III.
2. Warm engine up to normal operating temperature.

< COMPONENT DIAGNOSIS >

3. Maintain the following conditions for at least 50 consecutive seconds.

CAUTION:

Always drive vehicle at a safe speed.

ENG SPEED	1,400 - 6,000 rpm
COOLAN TEMP/S	More than 70°C (158°F)
B/FUEL SCHDL	5.5 - 31.8 msec
Selector lever	Except P or N position
PW/ST SIGNAL	OFF

4. Check 1st trip DTC.

Is 1st trip DTC detected?

YES >> Go to [EC-334, "Diagnosis Procedure"](#).

NO >> INSPECTION END

5.PERFORM COMPONENT FUNCTION CHECK

Perform Component Function Check. Refer to [EC-334, "Component Function Check"](#).

Use Component Function Check to check the overall function of the vehicle speed signal circuit. During this check, a 1st trip DTC might not be confirmed.

Is the inspection result normal?

YES >> INSPECTION END

NO >> Go to [EC-334, "Diagnosis Procedure"](#).

Component Function Check

INFOID:000000003388102

1.PERFORM COMPONENT FUNCTION CHECK

 **With GST**

1. Lift up drive wheels.

2. Start engine.

3. Read vehicle speed signal in Service \$01 with GST.

The vehicle speed signal on GST should be able to exceed 10 km/h (6 MPH) when rotating wheels with suitable gear position.

Is the inspection result normal?

YES >> INSPECTION END

NO >> Go to [EC-334, "Diagnosis Procedure"](#).

Diagnosis Procedure

INFOID:000000003388103

1.CHECK DTC WITH “ABS ACTUATOR AND ELECTRIC UNIT (CONTROL UNIT)”

Refer to [BRC-29, "CONSULT-III Function"](#).

Is the inspection result normal?

YES >> GO TO 2.

NO >> Repair or replace malfunctioning part.

2.CHECK COMBINATION METER FUNCTION

Refer to [MWI-34, "CONSULT-III Function \(METER/M&A\)"](#).

>> INSPECTION END

P0506 ISC SYSTEM

Description

INFOID:000000003388104

The ECM controls the engine idle speed to a specified level through the fine adjustment of the air, which is let into the intake manifold, by operating the electric throttle control actuator. The operating of the throttle valve is varied to allow for optimum control of the engine idling speed. The crankshaft position sensor (POS) detects the actual engine speed and sends a signal to the ECM.

The ECM controls the electric throttle control actuator so that the engine speed coincides with the target value memorized in the ECM. The target engine speed is the lowest speed at which the engine can operate steadily. The optimum value stored in the ECM is determined by taking into consideration various engine conditions, such as during warming up, deceleration and engine load (air conditioner, power steering and cooling fan operation, etc.).

DTC Logic

INFOID:000000003388105

DTC DETECTION LOGIC

NOTE:

If DTC P0506 is displayed with other DTC, first perform the trouble diagnosis for the other DTC.

DTC No.	Trouble diagnosis name	DTC detecting condition	Possible cause
P0506	Idle speed control system RPM lower than expected	The idle speed is less than the target idle speed by 100 rpm or more.	<ul style="list-style-type: none"> • Electric throttle control actuator • Intake air leakage

DTC CONFIRMATION PROCEDURE

1. PRECONDITIONING

If DTC Confirmation Procedure has been previously conducted, always perform the following before conducting the next test.

1. Turn ignition switch OFF and wait at least 10 seconds.
2. Turn ignition switch ON.
3. Turn ignition switch OFF and wait at least 10 seconds.

If the target idle speed is out of the specified value, perform [EC-17, "IDLE AIR VOLUME LEARNING : Special Repair Requirement"](#), before conducting DTC CONFIRMATION PROCEDURE.

TESTING CONDITION:

- Before performing the following procedure, confirm that battery voltage is more than 11 V at idle.
- Always perform the test at a temperature above -10°C(14°F).

>> GO TO 2.

2. PERFORM DTC CONFIRMATION PROCEDURE

1. Start engine and warm it up to normal operating temperature.
2. Turn ignition switch OFF and wait at least 10 seconds.
3. Turn ignition switch ON.
4. Turn ignition switch OFF and wait at least 10 seconds.
5. Restart engine and run it for at least 1 minute at idle speed.
6. Check 1st trip DTC.

Is 1st trip DTC detected?

- YES >> Go to [EC-335, "Diagnosis Procedure"](#).
- NO >> INSPECTION END

Diagnosis Procedure

INFOID:000000003388106

1. CHECK INTAKE AIR LEAKAGE

1. Start engine and let it idle.
2. Listen for an intake air leakage after the mass air flow sensor.

Is intake air leakage detected?

P0506 ISC SYSTEM

[VQ35DE]

< COMPONENT DIAGNOSIS >

- YES >> Discover air leakage location and repair.
- NO >> GO TO 2.

2.REPLACE ECM

1. Stop engine.
2. Replace ECM.
3. Go to [EC-15, "ADDITIONAL SERVICE WHEN REPLACING CONTROL UNIT : Special Repair Requirement"](#).

>> INSPECTION END

P0507 ISC SYSTEM

Description

INFOID:000000003591663

The ECM controls the engine idle speed to a specified level through the fine adjustment of the air, which is let into the intake manifold, by operating the electric throttle control actuator. The operating of the throttle valve is varied to allow for optimum control of the engine idling speed. The crankshaft position sensor (POS) detects the actual engine speed and sends a signal to the ECM.

The ECM controls the electric throttle control actuator so that the engine speed coincides with the target value memorized in the ECM. The target engine speed is the lowest speed at which the engine can operate steadily. The optimum value stored in the ECM is determined by taking into consideration various engine conditions, such as during warming up, deceleration and engine load (air conditioner, power steering and cooling fan operation, etc.).

DTC Logic

INFOID:000000003388108

DTC DETECTION LOGIC

NOTE:

If DTC P0507 is displayed with other DTC, first perform the trouble diagnosis for the other DTC.

DTC No.	Trouble diagnosis name	DTC detecting condition	Possible cause
P0507	Idle speed control system RPM higher than expected	The idle speed is more than the target idle speed by 200 rpm or more.	<ul style="list-style-type: none"> • Electric throttle control actuator • Intake air leakage • PCV system

DTC CONFIRMATION PROCEDURE

1. PRECONDITIONING

If DTC Confirmation Procedure has been previously conducted, always perform the following before conducting the next test.

1. Turn ignition switch OFF and wait at least 10 seconds.
2. Turn ignition switch ON.
3. Turn ignition switch OFF and wait at least 10 seconds.

If the target idle speed is out of the specified value, perform [EC-17, "IDLE AIR VOLUME LEARNING : Special Repair Requirement"](#), before conducting DTC Confirmation Procedure.

TESTING CONDITION:

- Before performing the following procedure, confirm that battery voltage is more than 11 V at idle.
- Always perform the test at a temperature above -10°C(14°F).

>> GO TO 2.

2. PERFORM DTC CONFIRMATION PROCEDURE

1. Start engine and warm it up to normal operating temperature.
2. Turn ignition switch OFF and wait at least 10 seconds.
3. Turn ignition switch ON.
4. Turn ignition switch OFF and wait at least 10 seconds.
5. Restart engine and run it for at least 1 minute at idle speed.
6. Check 1st trip DTC.

Is 1st trip DTC detected?

- YES >> Go to [EC-337, "Diagnosis Procedure"](#).
- NO >> INSPECTION END

Diagnosis Procedure

INFOID:000000003388109

1. CHECK PCV HOSE CONNECTION

Confirm that PCV hose is connected correctly.

Is the inspection result normal?

- YES >> GO TO 2.

< COMPONENT DIAGNOSIS >

NO >> Repair or replace malfunctioning part.

2.CHECK INTAKE AIR LEAKAGE

1. Start engine and let it idle.
2. Listen for an intake air leakage after the mass air flow sensor.

Is intake air leakage detected?

YES >> Discover air leakage location and repair.

NO >> GO TO 3.

3.REPLACE ECM

1. Stop engine.
2. Replace ECM.
3. Go to [EC-15. "ADDITIONAL SERVICE WHEN REPLACING CONTROL UNIT : Special Repair Requirement"](#).

>> INSPECTION END

P0550 PSP SENSOR

< COMPONENT DIAGNOSIS >

[VQ35DE]

P0550 PSP SENSOR

Description

INFOID:000000003388110

Power steering pressure (PSP) sensor is installed to the power steering high-pressure tube and detects a power steering load.

This sensor is a potentiometer which transforms the power steering load into output voltage, and emits the voltage signal to the ECM. The ECM controls the electric throttle control actuator and adjusts the throttle valve opening angle to increase the engine speed and adjusts the idle speed for the increased load.

DTC Logic

INFOID:000000003388111

DTC DETECTION LOGIC

NOTE:

If DTC P0550 is displayed with DTC P0643, first perform the trouble diagnosis for DTC P0643. Refer to [EC-347, "DTC Logic"](#).

DTC No.	Trouble diagnosis name	DTC detecting condition	Possible cause
P0550	Power steering pressure sensor circuit	An excessively low or high voltage from the sensor is sent to ECM.	<ul style="list-style-type: none"> Harness or connectors (The sensor circuit is open or shorted) Power steering pressure sensor

DTC CONFIRMATION PROCEDURE

1. PRECONDITIONING

If DTC Confirmation Procedure has been previously conducted, always perform the following before conducting the next test.

- Turn ignition switch OFF and wait at least 10 seconds.
- Turn ignition switch ON.
- Turn ignition switch OFF and wait at least 10 seconds.

>> GO TO 2.

2. PERFORM DTC CONFIRMATION PROCEDURE

- Start engine and let it idle for at least 5 seconds.
- Check 1st trip DTC.

Is 1st trip DTC detected?

- YES >> Go to [EC-339, "Diagnosis Procedure"](#).
 NO >> INSPECTION END

Diagnosis Procedure

INFOID:000000003388112

1. CHECK GROUND CONNECTION

- Turn ignition switch OFF.
- Check ground connection E38. Refer to Ground Inspection in [GI-43, "Circuit Inspection"](#).

Is the inspection result normal?

- YES >> GO TO 2.
 NO >> Repair or replace ground connection.

2. CHECK PSP SENSOR POWER SUPPLY CIRCUIT

- Disconnect power steering pressure (PSP) sensor harness connector.
- Turn ignition switch ON.
- Check the voltage between PSP sensor harness connector and ground.

PSP sensor		Ground	Voltage
Connector	Terminal		
F62	3	Ground	Approx. 5 V

P0550 PSP SENSOR

[VQ35DE]

< COMPONENT DIAGNOSIS >

Is the inspection result normal?

YES >> GO TO 3.

NO >> Repair open circuit, short to ground or short to power in harness or connectors.

3.CHECK PSP SENSOR GROUND CIRCUIT FOR OPEN AND SHORT

1. Turn ignition switch OFF.
2. Disconnect ECM harness connector.
3. Check the continuity between PSP sensor harness connector and ECM harness connector.

PSP sensor		ECM		Continuity
Connector	Terminal	Connector	Terminal	
F62	1	F8	48	Existed

4. Also check harness for short to ground and short to power.

Is the inspection result normal?

YES >> GO TO 4.

NO >> Repair open circuit, short to ground short to power in harness or connectors.

4.CHECK PSP SENSOR INPUT SIGNAL CIRCUIT FOR OPEN AND SHORT

1. Check the continuity between PSP sensor harness connector and ECM harness connector.

PSP sensor		ECM		Continuity
Connector	Terminal	Connector	Terminal	
F62	2	F8	41	Existed

2. Also check harness for short to ground and short to power.

Is the inspection result normal?

YES >> GO TO 5.

NO >> Repair open circuit, short to ground or short to power in harness or connectors.

5.CHECK PSP SENSOR

Refer to [EC-340, "Component Inspection"](#).

Is the inspection result normal?

YES >> GO TO 6.

NO >> Replace PSP sensor.

6.CHECK INTERMITTENT INCIDENT

Refer to [GI-40, "Intermittent Incident"](#).

>> INSPECTION END

Component Inspection

INFOID:000000003388113

1.CHECK POWER STEERING PRESSURE SENSOR

1. Reconnect all harness connectors disconnected.
2. Start engine and let it idle.
3. Check the voltage between ECM terminals under the following conditions.

Connector	ECM		Condition	Voltage
	+	-		
	Terminal	Terminal		
F8	41 (Power steering pressure sensor signal)	48 (Sensor ground)	Steering wheel: Being turned.	0.5 - 4.5 V
			Steering wheel: Not being turned.	0.4 - 0.8 V

Is the inspection result normal?

P0550 PSP SENSOR

< COMPONENT DIAGNOSIS >

[VQ35DE]

YES >> INSPECTION END
NO >> Replace power steering pressure sensor.

A

EC

C

D

E

F

G

H

I

J

K

L

M

N

O

P

P0603 ECM POWER SUPPLY

Description

INFOID:000000003388114

Battery voltage is supplied to the ECM even when the ignition switch is turned OFF for the ECM memory function of the DTC memory, the air-fuel ratio feedback compensation value memory, the idle air volume learning value memory, etc.

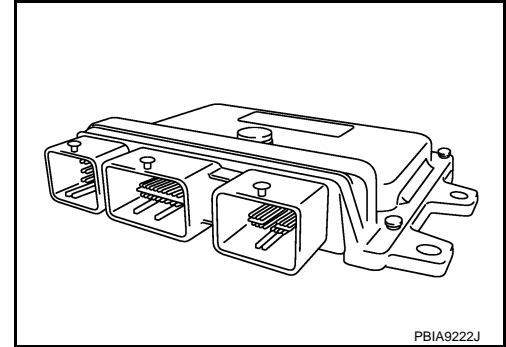

PBIA9222J

DTC Logic

INFOID:000000003388115

DTC DETECTION LOGIC

DTC No.	Trouble diagnosis name	DTC detecting condition	Possible cause
P0603	ECM power supply circuit	ECM back up RAM system does not function properly.	<ul style="list-style-type: none"> • Harness or connectors [ECM power supply (back up) circuit is open or shorted.] • ECM

DTC CONFIRMATION PROCEDURE

1. PRECONDITIONING

If DTC Confirmation Procedure has been previously conducted, always perform the following before conducting the next test.

1. Turn ignition switch OFF and wait at least 10 seconds.
2. Turn ignition switch ON.
3. Turn ignition switch OFF and wait at least 10 seconds.

>> GO TO 2.

2. PERFORM DTC CONFIRMATION PROCEDURE

1. Turn ignition switch ON and wait at least 1 second.
2. Start engine and let it idle for 1 second.
3. Turn ignition switch OFF, wait at least 10 seconds, and then turn it ON.
4. Repeat steps 2 and 3 for 4 times.
5. Check 1st trip DTC.

Is 1st trip DTC detected?

- YES >> Go to [EC-342, "Diagnosis Procedure"](#).
- NO >> INSPECTION END

Diagnosis Procedure

INFOID:000000003388116

1. CHECK ECM POWER SUPPLY

1. Turn ignition switch OFF.
2. Disconnect ECM harness connector.
3. Check the voltage between ECM harness connector terminals.

P0603 ECM POWER SUPPLY

< COMPONENT DIAGNOSIS >

[VQ35DE]

ECM				Voltage
+		-		
Connector	Terminal	Connector	Terminal	
F8	77	E16	112	Battery voltage

A

EC

Is the inspection result normal?

- YES >> GO TO 3.
- NO >> GO TO 2.

C

2. DETECT MALFUNCTIONING PART

Check the following.

- 15 A fuse (No. 50)
- IPDM E/R harness connector F12
- Harness for open or short between ECM and battery

D

E

>> Repair or replace harness or connectors.

3. CHECK INTERMITTENT INCIDENT

F

Refer to [GI-40, "Intermittent Incident"](#).

Is the inspection result normal?

G

- YES >> GO TO 4.
- NO >> Repair or replace harness or connectors.

4. PERFORM DTC CONFIRMATION PROCEDURE

H

1. Turn ignition switch ON.
2. Erase DTC.
3. Perform DTC CONFIRMATION PROCEDURE.
See [EC-342, "DTC Logic"](#).

I

Is the 1st trip DTC P0603 displayed again?

J

- YES >> GO TO 5.
- NO >> INSPECTION END

5. REPLACE ECM

K

1. Replace ECM.
2. Go to [EC-15, "ADDITIONAL SERVICE WHEN REPLACING CONTROL UNIT : Special Repair Requirement"](#).

L

>> INSPECTION END

M

N

O

P

P0605 ECM

Description

INFOID:000000003388117

The ECM consists of a microcomputer and connectors for signal input and output and for power supply. The ECM controls the engine.

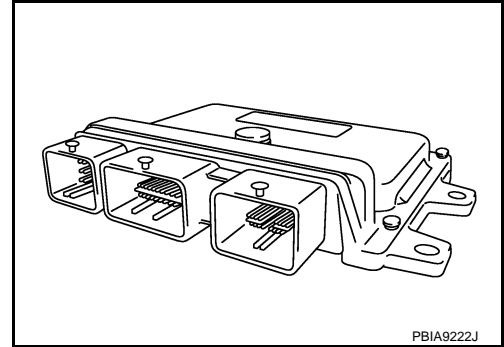

DTC Logic

INFOID:000000003388118

DTC DETECTION LOGIC

DTC No.	Trouble diagnosis name	DTC detecting condition		Possible cause
P0605	Engine control module	A)	ECM calculation function is malfunctioning.	• ECM
		B)	ECM EEP-ROM system is malfunctioning.	
		C)	ECM self shut-off function is malfunctioning.	

DTC CONFIRMATION PROCEDURE

1. PRECONDITIONING

If DTC Confirmation Procedure has been previously conducted, always perform the following before conducting the next test.

1. Turn ignition switch OFF and wait at least 10 seconds.
2. Turn ignition switch ON.
3. Turn ignition switch OFF and wait at least 10 seconds.

>> GO TO 2.

2. PERFORM DTC CONFIRMATION PROCEDURE FOR MALFUNCTION A

1. Turn ignition switch ON.
2. Check 1st trip DTC.

Is 1st trip DTC detected?

YES >> Go to [EC-345, "Diagnosis Procedure"](#).

NO >> GO TO 3.

3. PERFORM DTC CONFIRMATION PROCEDURE FOR MALFUNCTION B

1. Turn ignition switch ON and wait at least 1 second.
2. Turn ignition switch OFF, wait at least 10 seconds, and then turn it ON.
3. Check 1st trip DTC.

Is 1st trip DTC detected?

YES >> Go to [EC-345, "Diagnosis Procedure"](#).

NO >> GO TO 4.

4. PERFORM DTC CONFIRMATION PROCEDURE FOR MALFUNCTION C

1. Turn ignition switch ON and wait at least 1 second.
2. Turn ignition switch OFF, wait at least 10 seconds, and then turn it ON.
3. Repeat step 2 for 32 times.
4. Check 1st trip DTC.

Is 1st trip DTC detected?

- YES >> Go to [EC-345. "Diagnosis Procedure"](#).
- NO >> INSPECTION END

A

Diagnosis Procedure

INFOID:000000003388119

1.INSPECTION START

EC

- 1. Turn ignition switch ON.
- 2. Erase DTC.
- 3. Perform DTC CONFIRMATION PROCEDURE.
See [EC-344. "DTC Logic"](#).

C

Is the 1st trip DTC P0605 displayed again?

D

- YES >> GO TO 2.
- NO >> INSPECTION END

2.REPLACE ECM

E

- 1. Replace ECM.
- 2. Go to [EC-15. "ADDITIONAL SERVICE WHEN REPLACING CONTROL UNIT : Special Repair Requirement"](#).

F

>> INSPECTION END

G

H

I

J

K

L

M

N

O

P

P0607 ECM

Description

INFOID:000000003388120

CAN (Controller Area Network) is a serial communication line for real time application. It is an on-vehicle multiplex communication line with high data communication speed and excellent error detection ability. Many electronic control units are equipped onto a vehicle, and each control unit shares information and links with other control units during operation (not independent). In CAN communication, control units are connected with 2 communication lines (CAN H line, CAN L line) allowing a high rate of information transmission with less wiring. Each control unit transmits/receives data but selectively reads required data only.

DTC Logic

INFOID:000000003388121

DTC DETECTION LOGIC

DTC No.	Trouble diagnosis name	DTC detecting condition	Possible cause
P0607	CAN communication bus	When detecting error during the initial diagnosis of CAN controller of ECM.	<ul style="list-style-type: none"> ECM

DTC CONFIRMATION PROCEDURE

1.PERFORM DTC CONFIRMATION PROCEDURE

1. Turn ignition switch ON.
2. Check DTC.

Is DTC detected?

- YES >> Go to [EC-346. "Diagnosis Procedure"](#).
- NO >> INSPECTION END

Diagnosis Procedure

INFOID:000000003388122

1.INSPECTION START

1. Turn ignition switch ON.
2. Erase DTC.
3. Perform DTC CONFIRMATION PROCEDURE.
See [EC-346. "DTC Logic"](#).
4. Check DTC.

Is the DTC P0607 displayed again?

- Yes >> GO TO 2.
- No >> INSPECTION END

2.REPLACE ECM

1. Replace ECM.
2. Go to [EC-15. "ADDITIONAL SERVICE WHEN REPLACING CONTROL UNIT : Special Repair Requirement"](#).

>> INSPECTION END

P0643 SENSOR POWER SUPPLY

< COMPONENT DIAGNOSIS >

[VQ35DE]

P0643 SENSOR POWER SUPPLY

DTC Logic

INFOID:000000003388123

DTC DETECTION LOGIC

DTC No.	Trouble diagnosis name	DTC detecting condition	Possible cause
P0643	Sensor power supply circuit short	ECM detects that the voltage of power source for sensor is excessively low or high.	<ul style="list-style-type: none"> • Harness or connectors (APP sensor 1 circuit is shorted.) (TP sensor circuit is shorted.) [CMP sensor (PHASE) circuit is shorted.] (PSP sensor circuit is shorted.) (Battery current sensor circuit is shorted.) • Accelerator pedal position sensor • Throttle position sensor • Camshaft position sensor (PHASE) • Power steering pressure sensor • Battery current sensor

DTC CONFIRMATION PROCEDURE

1. PRECONDITIONING

If DTC Confirmation Procedure has been previously conducted, always perform the following before conducting the next test.

1. Turn ignition switch OFF and wait at least 10 seconds.
2. Turn ignition switch ON.
3. Turn ignition switch OFF and wait at least 10 seconds.

TESTING CONDITION:

Before performing the following procedure, confirm that battery voltage is more than 10 V at idle.

>> GO TO 2.

2. PERFORM DTC CONFIRMATION PROCEDURE

1. Start engine and let it idle for 1 second.
2. Check DTC

Is DTC detected?

- YES >> Go to [EC-347, "Diagnosis Procedure"](#).
 NO >> INSPECTION END

Diagnosis Procedure

INFOID:000000003388124

1. CHECK GROUND CONNECTION

1. Turn ignition switch OFF.
2. Check ground connection E38. Refer to Ground Inspection in [GI-43, "Circuit Inspection"](#).

Is the inspection result normal?

- YES >> GO TO 2.
 NO >> Repair or replace ground connection.

2. CHECK ACCELERATOR PEDAL POSITION SENSOR 1 POWER SUPPLY CIRCUIT

1. Disconnect accelerator pedal position (APP) sensor harness connector.
2. Turn ignition switch ON.
3. Check the voltage between APP sensor harness connector and ground.

APP sensor		Ground	Voltage (V)
Connector	Terminal		
E110	4	Ground	Approx. 5

P0643 SENSOR POWER SUPPLY

[VQ35DE]

< COMPONENT DIAGNOSIS >

Is the inspection result normal?

- YES >> GO TO 7.
- NO >> GO TO 3.

3.CHECK SENSOR POWER SUPPLY CIRCUIT

Check harness for short to power and short to ground, between the following terminals.

ECM		Sensor		
Connector	Terminal	Name	Connector	Terminal
F8	47	TP sensor	F29	1
	51	Battery current sensor	F76	1
	55	PSP sensor	F62	3
	59	CMP sensor (PHASE) (bank 1)	F26	1
	63	CMP sensor (PHASE) (bank 2)	F69	1
E16	83	APP sensor	E110	4

Is the inspection result normal?

- YES >> GO TO 4.
- NO >> Repair short to ground or short to power in harness or connectors.

4.CHECK COMPONENTS

Check the following.

- Camshaft position sensor (PHASE) (Refer to [EC-266, "Component Inspection"](#).)
- Battery current sensor (Refer to [EC-366, "Component Inspection"](#).)
- Power steering pressure sensor (Refer to [EC-340, "Component Inspection"](#).)

Is the inspection result normal?

- YES >> GO TO 5.
- NO >> Replace malfunctioning component.

5.CHECK TP SENSOR

Refer to [EC-177, "Component Inspection"](#).

Is the inspection result normal?

- YES >> GO TO 9.
- NO >> GO TO 6.

6.REPLACE ELECTRIC THROTTLE CONTROL ACTUATOR

1. Replace electric throttle control actuator.
2. Go to [EC-177, "Special Repair Requirement"](#).

>> INSPECTION END

7.CHECK APP SENSOR

Refer to [EC-415, "Component Inspection"](#).

Is the inspection result normal?

- YES >> GO TO 9.
- NO >> GO TO 8.

8.REPLACE ACCELERATOR PEDAL ASSEMBLY

1. Replace accelerator pedal assembly.
2. Go to [EC-415, "Special Repair Requirement"](#).

>> INSPECTION END

9.CHECK INTERMITTENT INCIDENT

Refer to [GI-40, "Intermittent Incident"](#).

P0643 SENSOR POWER SUPPLY

< COMPONENT DIAGNOSIS >

[VQ35DE]

>> INSPECTION END

A

EC

C

D

E

F

G

H

I

J

K

L

M

N

O

P

P0850 PNP SWITCH

< COMPONENT DIAGNOSIS >

[VQ35DE]

P0850 PNP SWITCH

Description

INFOID:000000003388125

When the selector lever position is P or N, park/neutral position (PNP) signal from the TCM is sent to ECM.

DTC Logic

INFOID:000000003388126

DTC DETECTION LOGIC

DTC No.	Trouble diagnosis name	DTC detecting condition	Possible cause
P0850	Park/neutral position switch	The signal of the park/neutral position (PNP) signal does not change during driving after the engine is started.	<ul style="list-style-type: none">• Harness or connectors [The park/neutral position (PNP) signal circuit is open or shorted.]• TCM

DTC CONFIRMATION PROCEDURE

1. INSPECTION START

Will CONSULT-III be used?

Will CONSULT-III be used?

YES >> GO TO 2.

NO >> GO TO 5.

2. PRECONDITIONING

If DTC Confirmation Procedure has been previously conducted, always perform the following before conducting the next test.

1. Turn ignition switch OFF and wait at least 10 seconds.
2. Turn ignition switch ON.
3. Turn ignition switch OFF and wait at least 10 seconds.

>> GO TO 3.

3. CHECK PNP SIGNAL

 **With CONSULT-III**

1. Turn ignition switch ON.
2. Select "P/N POSI SW" in "DATA MONITOR" mode with CONSULT-III. Then check the "P/N POSI SW" signal under the following conditions.

Position (Selector lever)	Known-good signal
N or P position	ON
Except above position	OFF

Is the inspection result normal?

YES >> GO TO 4.

NO >> Go to [EC-351, "Diagnosis Procedure"](#).

4. PERFORM DTC CONFIRMATION PROCEDURE

1. Select "DATA MONITOR" mode with CONSULT-III.
2. Start engine and warm it up to normal operating temperature.
3. Maintain the following conditions for at least 50 consecutive seconds.

CAUTION:

Always drive vehicle at a safe speed.

ENG SPEED	1,100 - 6,375 rpm
COOLAN TEMP/S	More than 70°C (158°F)
B/FUEL SCHDL	4.0 - 31.8 msec

P0850 PNP SWITCH

[VQ35DE]

< COMPONENT DIAGNOSIS >

VHCL SPEED SE	More than 64 km/h (40 mph)
Selector lever	Suitable position

4. Check 1st trip DTC.

Is 1st trip DTC detected?

YES >> Go to [EC-351, "Diagnosis Procedure"](#).

NO >> INSPECTION END

5.PERFORM COMPONENT FUNCTION CHECK

Perform component function check. Refer to [EC-351, "Component Function Check"](#).

NOTE:

Use component function check to check the overall function of the park/neutral position (PNP) signal circuit. During this check, a 1st trip DTC might not be confirmed.

Is the inspection result normal?

YES >> INSPECTION END

NO >> Go to [EC-351, "Diagnosis Procedure"](#).

Component Function Check

INFOID:000000003388127

1.PERFORM COMPONENT FUNCTION CHECK

1. Turn ignition switch ON.
2. Check the voltage between ECM harness connector terminals.

ECM			Condition	Voltage	
Connector	+	-			
	Terminal	Terminal			
E16	102	112	Selector lever position	P or N	Battery voltage
				Except above	Approx. 0 V

Is the inspection result normal?

YES >> INSPECTION END

NO >> Go to [EC-351, "Diagnosis Procedure"](#).

Diagnosis Procedure

INFOID:000000003388128

1.CHECK DTC WITH TCM

Refer to [EC-521, "DTC Index"](#).

Is the inspection result normal?

YES >> GO TO 2.

NO >> Repair or replace malfunctioning part.

2.CHECK STARTING SYSTEM

Turn ignition switch OFF, then turn it to START.

Does starter motor operate?

YES >> GO TO 3.

NO >> Refer to [BCS-17, "COMMON ITEM : CONSULT-III Function \(BCM - COMMON ITEM\)"](#).

3.CHECK PNP SWITCH INPUT SIGNAL CIRCUIT FOR OPEN AND SHORT-I

1. Turn ignition switch OFF.
2. Disconnect TCM harness connector.
3. Disconnect IPDM E/R harness connector.
4. Check the continuity between TCM harness connector and IPDM E/R harness connector.

P0850 PNP SWITCH

[VQ35DE]

< COMPONENT DIAGNOSIS >

TCM		IPDM E/R		Continuity
Connector	Terminal	Connector	Terminal	
F23	20	F12	72	Existed

5. Also check harness for short to ground and short to power.

Is the inspection result normal?

YES >> GO TO 4.

NO >> Repair open circuit, short to ground or short to power in harness or connectors.

4.CHECK PNP SIGNAL CIRCUIT FOR OPEN AND SHORT-II

1. Disconnect IPDM E/R harness connectors.
2. Disconnect ECM harness connector.
3. Check the continuity between ECM harness connector and IPDM E/R harness connector.

ECM		IPDM E/R		Continuity
Connector	Terminal	Connector	Terminal	
E16	102	E10	30	Existed

4. Also check harness for short to ground and short to power.

Is the inspection result normal?

YES >> GO TO 5.

NO >> Repair open circuit, short to ground or short to power in harness or connectors.

5.CHECK INTERMITTENT INCIDENT

Refer to [GI-40, "Intermittent Incident"](#).

>> Repair or replace malfunctioning part.

P1148, P1168 CLOSED LOOP CONTROL

< COMPONENT DIAGNOSIS >

[VQ35DE]

P1148, P1168 CLOSED LOOP CONTROL

DTC Logic

INFOID:000000003388129

DTC DETECTION LOGIC

NOTE:

DTC P1148 or P1168 is displayed with another DTC for A/F sensor 1. Perform the trouble diagnosis for the corresponding DTC.

DTC No.	Trouble diagnosis name	DTC detecting condition	Possible cause
P1148	Closed loop control function (bank 1)	The closed loop control function for bank 1 does not operate even when vehicle is being driven in the specified condition.	<ul style="list-style-type: none">• Harness or connectors (The A/F sensor 1 circuit is open or shorted.)• A/F sensor 1• A/F sensor 1 heater
P1168	Closed loop control function (bank 2)	The closed loop control function for bank 2 does not operate even when vehicle is being driven in the specified condition.	

A
EC
C
D
E
F
G
H
I
J
K
L
M
N
O
P

P1212 TCS COMMUNICATION LINE

< COMPONENT DIAGNOSIS >

[VQ35DE]

P1212 TCS COMMUNICATION LINE

Description

INFOID:000000003388130

This CAN communication line is used to control the smooth engine operation during the TCS operation. Pulse signals are exchanged between ECM and “ABS actuator and electric unit (control unit)”.

Be sure to erase the malfunction information such as DTC not only for “ABS actuator and electric unit (control unit)” but also for ECM after TCS related repair.

DTC Logic

INFOID:000000003388131

DTC DETECTION LOGIC

NOTE:

- If DTC P1212 is displayed with DTC UXXXX, first perform the trouble diagnosis for DTC UXXXX.
- If DTC P1212 is displayed with DTC P0607, first perform the trouble diagnosis for DTC P0607. Refer to [EC-346, "DTC Logic"](#).

Freeze frame data is not stored in the ECM for this self-diagnosis.

DTC No.	Trouble diagnosis name	DTC detecting condition	Possible cause
P1212	TCS communication line	ECM cannot receive the information from “ABS actuator and electric unit (control unit)” continuously.	<ul style="list-style-type: none">• Harness or connectors (The CAN communication line is open or shorted.)• ABS actuator and electric unit (control unit)• Dead (Weak) battery

DTC CONFIRMATION PROCEDURE

1. PRECONDITIONING

If DTC Confirmation Procedure has been previously conducted, always perform the following before conducting the next test

1. Turn ignition switch OFF and wait at least 10 seconds.
2. Turn ignition switch ON.
3. Turn ignition switch OFF and wait at least 10 seconds.

TESTING CONDITION:

Before performing the following procedure, confirm that battery voltage is more than 10.5 V at idle.

>> GO TO 2.

2. PERFORM DTC CONFIRMATION PROCEDURE

1. Start engine and let it idle for at least 10 seconds.
2. Check 1st trip DTC.

Is 1st trip DTC detected?

- YES >> Go to [EC-354, "Diagnosis Procedure"](#).
NO >> INSPECTION END

Diagnosis Procedure

INFOID:000000003388132

Go to [BRC-5, "Work Flow"](#).

P1217 ENGINE OVER TEMPERATURE

< COMPONENT DIAGNOSIS >

[VQ35DE]

P1217 ENGINE OVER TEMPERATURE

DTC Logic

INFOID:000000003388133

DTC DETECTION LOGIC

NOTE:

- If DTC P1217 is displayed with DTC UXXXX, first perform the trouble diagnosis for DTC UXXXX.
- If DTC P1217 is displayed with DTC P0607, first perform the trouble diagnosis for DTC P0607. Refer to [EC-346, "DTC Logic"](#).

If the cooling fan or another component in the cooling system malfunctions, engine coolant temperature will rise.

When the engine coolant temperature reaches an abnormally high temperature condition, a malfunction is indicated.

DTC No.	Trouble diagnosis name	DTC detecting condition	Possible cause
P1217	Engine over temperature (Overheat)	<ul style="list-style-type: none">• Cooling fan does not operate properly (Overheat).• Cooling fan system does not operate properly (Overheat).• Engine coolant was not added to the system using the proper filling method.• Engine coolant is not within the specified range.	<ul style="list-style-type: none">• Harness or connectors (The cooling fan circuit is open or shorted.)• IPDM E/R (Cooling fan relays)• Cooling fan motor• Radiator hose• Radiator• Radiator cap• Water pump• Thermostat

CAUTION:

When a malfunction is indicated, always replace the coolant. Refer to [CO-8, "Draining"](#). Also, replace the engine oil. Refer to [LU-8, "Draining"](#).

1. Fill radiator with coolant up to specified level with a filling speed of 2 liters per minute. Always use coolant with the proper mixture ratio. Refer to [MA-16, "FOR NORTH AMERICA : Anti-Freeze Coolant Mixture Ratio"](#).
2. After refilling coolant, run engine to ensure that no water-flow noise is emitted.

DTC CONFIRMATION PROCEDURE

1. PERFORM COMPONENT FUNCTION CHECK

Perform component function check. Refer to [EC-355, "Component Function Check"](#).

NOTE:

Use component function check to check the overall function of the cooling fan. During this check, a DTC might not be confirmed.

Is the inspection result normal?

YES >> INSPECTION END

NO >> Go to [EC-356, "Diagnosis Procedure"](#).

Component Function Check

INFOID:000000003388134

1. PERFORM COMPONENT FUNCTION CHECK-I

WARNING:

Never remove the radiator cap when the engine is hot. Serious burns could be caused by high pressure fluid escaping from the radiator.

Wrap a thick cloth around cap. Carefully remove the cap by turning it a quarter turn to allow built-up pressure to escape. Then turn the cap all the way off.

P1217 ENGINE OVER TEMPERATURE

[VQ35DE]

< COMPONENT DIAGNOSIS >

Check the coolant level in the reservoir tank and radiator.

Allow engine to cool before checking coolant level.

Is the coolant level in the reservoir tank and/or radiator below the proper range?

- YES >> Go to [EC-356, "Diagnosis Procedure"](#).
NO >> GO TO 2.

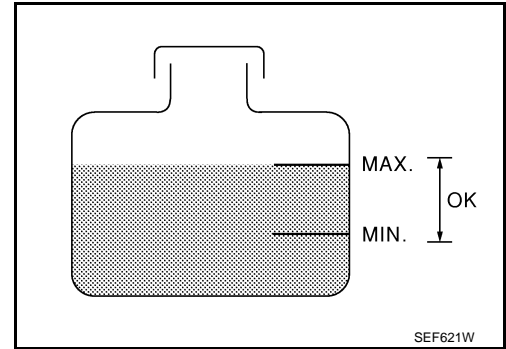

2.PERFORM COMPONENT FUNCTION CHECK-II

Confirm whether customer filled the coolant or not.

Did customer fill the coolant?

- YES >> Go to [EC-356, "Diagnosis Procedure"](#).
NO >> GO TO 3.

3.PERFORM COMPONENT FUNCTION CHECK-III

With CONSULT-III

1. Turn ignition switch ON.
2. Perform "COOLING FAN" in "ACTIVE TEST" mode with CONSULT-III.
3. Check that cooling fan motors-1 and -2 operate at each speed (LOW/MID/HI).

Without CONSULT-III

Perform IPDM E/R auto active test and check cooling fan motors operation, refer to [PCS-10, "Diagnosis Description"](#).

Is the inspection result normal?

- YES >> INSPECTION END
NO >> Go to [EC-356, "Diagnosis Procedure"](#).

Diagnosis Procedure

INFOID:000000003388135

1.CHECK COOLING FAN OPERATION

With CONSULT-III

1. Turn ignition switch ON.
2. Perform "COOLING FAN" in "ACTIVE TEST" mode with CONSULT-III.
3. Check that cooling fans-1 and -2 operate at each speed (LOW/MID/HI).

Without CONSULT-III

1. Perform IPDM E/R auto active test and check cooling fan motors operation, refer to [PCS-10, "Diagnosis Description"](#).
2. Check that cooling fans-1 and -2 operate at each speed (Low/Middle/High).

Is the inspection result normal?

- YES >> GO TO 2.
NO >> Go to [EC-434, "Diagnosis Procedure"](#).

2.CHECK COOLING SYSTEM FOR LEAKAGE-I

Check cooling system for leakage. Refer to [CO-8, "Inspection"](#).

Is leakage detected?

- YES >> GO TO 3.
NO >> GO TO 4.

3.CHECK COOLING SYSTEM FOR LEAKAGE-II

Check the following for leakage.

- Hose
- Radiator
- Water pump

P1217 ENGINE OVER TEMPERATURE

[VQ35DE]

< COMPONENT DIAGNOSIS >

>> Repair or replace malfunctioning part.

4. CHECK RADIATOR CAP

Check radiator cap. Refer to [CO-12, "RADIATOR CAP : Inspection"](#).

Is the inspection result normal?

YES >> GO TO 5.

NO >> Replace radiator cap.

5. CHECK THERMOSTAT

Check thermostat. Refer to [CO-24, "Inspection"](#).

Is the inspection result normal?

YES >> GO TO 6.

NO >> Replace thermostat

6. CHECK ENGINE COOLANT TEMPERATURE SENSOR

Refer to [EC-171, "Component Inspection"](#).

Is the inspection result normal?

YES >> GO TO 7.

NO >> Replace engine coolant temperature sensor.

7. CHECK MAIN 12 CAUSES

If the cause cannot be isolated, check the following.

Engine	Step	Inspection item	Equipment	Standard	Reference page
OFF	1	<ul style="list-style-type: none"> Blocked radiator Blocked condenser Blocked radiator grille Blocked bumper 	<ul style="list-style-type: none"> Visual 	No blocking	—
	2	<ul style="list-style-type: none"> Coolant mixture 	<ul style="list-style-type: none"> Coolant tester 	MA-15, "FOR NORTH AMERICA : Engine Oil Recommendation"	
	3	<ul style="list-style-type: none"> Coolant level 	<ul style="list-style-type: none"> Visual 	Coolant up to MAX level in reservoir tank and radiator filler neck	CO-8, "Inspection"
	4	<ul style="list-style-type: none"> Radiator cap 	<ul style="list-style-type: none"> Pressure tester 	CO-12, "RADIATOR CAP : Inspection"	
ON*2	5	<ul style="list-style-type: none"> Coolant leakage 	<ul style="list-style-type: none"> Visual 	No leakage	CO-8, "Inspection"
ON*2	6	<ul style="list-style-type: none"> Thermostat 	<ul style="list-style-type: none"> Touch the upper and lower radiator hoses 	Both hoses should be hot	CO-24, "Inspection"
ON*1	7	<ul style="list-style-type: none"> Cooling fan 	<ul style="list-style-type: none"> CONSULT-III 	Operating	EC-434, "Component Function Check"
OFF	8	<ul style="list-style-type: none"> Combustion gas leakage 	<ul style="list-style-type: none"> Color checker chemical tester 4 Gas analyzer 	Negative	—
ON*3	9	<ul style="list-style-type: none"> Coolant temperature gauge 	<ul style="list-style-type: none"> Visual 	Gauge less than 3/4 when driving	—
		<ul style="list-style-type: none"> Coolant overflow to reservoir tank 	<ul style="list-style-type: none"> Visual 	No overflow during driving and idling	CO-8, "Inspection"
OFF*4	10	<ul style="list-style-type: none"> Coolant return from reservoir tank to radiator 	<ul style="list-style-type: none"> Visual 	Should be initial level in reservoir tank	CO-8, "Inspection"
OFF	11	<ul style="list-style-type: none"> Cylinder head 	<ul style="list-style-type: none"> Straight gauge feeler gauge 	0.1 mm (0.004 in) Maximum distortion (warping)	EM-114, "Inspection"
	12	<ul style="list-style-type: none"> Cylinder block and pistons 	<ul style="list-style-type: none"> Visual 	No scuffing on cylinder walls or piston	EM-126, "Inspection"

*1: Turn the ignition switch ON.

*2: Engine running at 3,000 rpm for 10 minutes.

*3: Drive at 90 km/h (56 MPH) for 30 minutes and then let idle for 10 minutes.

*4: After 60 minutes of cool down time.

P1217 ENGINE OVER TEMPERATURE

< COMPONENT DIAGNOSIS >

[VQ35DE]

For more information, refer to [CO-3, "Troubleshooting Chart"](#).

>> INSPECTION END

P1225 TP SENSOR

< COMPONENT DIAGNOSIS >

[VQ35DE]

P1225 TP SENSOR

Description

INFOID:000000003591572

Electric throttle control actuator consists of throttle control motor, throttle position sensor, etc. The throttle position sensor responds to the throttle valve movement.

The throttle position sensor has two sensors. These sensors are a kind of potentiometer which transform the throttle valve position into output voltage, and emit the voltage signals to the ECM. The ECM judges the current opening angle of the throttle valve from these signals and controls the throttle valve opening angle in response to driving conditions via the throttle control motor.

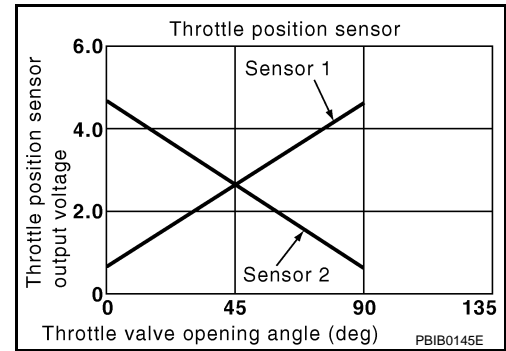

DTC Logic

INFOID:000000003388137

DTC DETECTION LOGIC

DTC No.	Trouble diagnosis name	DTC detecting condition	Possible cause
P1225	Closed throttle position learning performance	Closed throttle position learning value is excessively low.	• Electric throttle control actuator (TP sensor 1 and 2)

DTC CONFIRMATION PROCEDURE

1. PRECONDITIONING

If DTC Confirmation Procedure has been previously conducted, always perform the following before conducting the next test.

1. Turn ignition switch OFF and wait at least 10 seconds.
2. Turn ignition switch ON.
3. Turn ignition switch OFF and wait at least 10 seconds.

TESTING CONDITION:

Before performing the following procedure, confirm that battery voltage is more than 10 V at idle.

>> GO TO 2.

2. PERFORM DTC CONFIRMATION PROCEDURE

1. Turn ignition switch ON.
2. Turn ignition switch OFF and wait at least 10 seconds.
3. Turn ignition switch ON.
4. Check 1st trip DTC.

Is 1st trip DTC detected?

- YES >> Go to [EC-359, "Diagnosis Procedure"](#).
- NO >> INSPECTION END

Diagnosis Procedure

INFOID:000000003388138

1. CHECK ELECTRIC THROTTLE CONTROL ACTUATOR VISUALLY

1. Turn ignition switch OFF.
2. Remove the intake air duct.

P1225 TP SENSOR

[VQ35DE]

< COMPONENT DIAGNOSIS >

3. Check if foreign matter is caught between the throttle valve (1) and the housing.
 - Electric throttle control actuator (2)
 - ↵: Vehicle front

Is the inspection result normal?

YES >> GO TO 2.

NO >> Remove the foreign matter and clean the electric throttle control actuator inside.

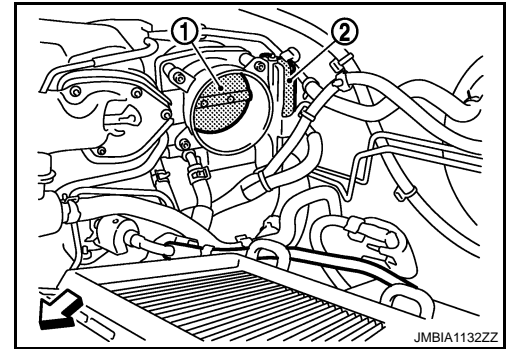

2.REPLACE ELECTRIC THROTTLE CONTROL ACTUATOR

1. Replace electric throttle control actuator.
2. Go to [EC-360. "Special Repair Requirement"](#).

>> INSPECTION END

Special Repair Requirement

INFOID:000000003591588

1.PERFORM THROTTLE VALVE CLOSED POSITION LEARNING

Refer to [EC-17, "THROTTLE VALVE CLOSED POSITION LEARNING : Special Repair Requirement"](#)

>> GO TO 2.

2.PERFORM IDLE AIR VOLUME LEARNING

Refer to [EC-17, "IDLE AIR VOLUME LEARNING : Special Repair Requirement"](#)

>> END

P1226 TP SENSOR

< COMPONENT DIAGNOSIS >

[VQ35DE]

P1226 TP SENSOR

Description

INFOID:000000003591573

Electric throttle control actuator consists of throttle control motor, throttle position sensor, etc. The throttle position sensor responds to the throttle valve movement.

The throttle position sensor has two sensors. These sensors are a kind of potentiometer which transform the throttle valve position into output voltage, and emit the voltage signals to the ECM. The ECM judges the current opening angle of the throttle valve from these signals and controls the throttle valve opening angle in response to driving conditions via the throttle control motor.

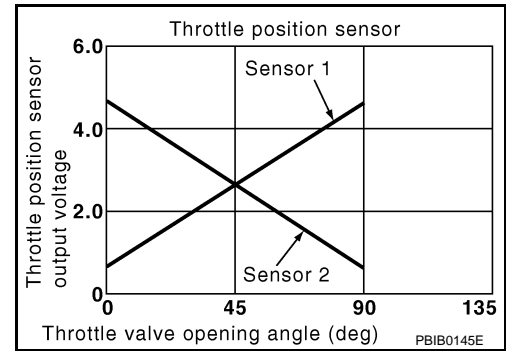

DTC Logic

INFOID:000000003388141

DTC DETECTION LOGIC

DTC No.	Trouble diagnosis name	DTC detecting condition	Possible cause
P1226	Closed throttle position learning performance	Closed throttle position learning is not performed successfully, repeatedly.	• Electric throttle control actuator (TP sensor 1 and 2)

DTC CONFIRMATION PROCEDURE

1. PRECONDITIONING

If DTC Confirmation Procedure has been previously conducted, always perform the following before conducting the next test.

1. Turn ignition switch OFF and wait at least 10 seconds.
2. Turn ignition switch ON.
3. Turn ignition switch OFF and wait at least 10 seconds.

TESTING CONDITION:

Before performing the following procedure, confirm that battery voltage is more than 10 V at idle.

>> GO TO 2.

2. PERFORM DTC CONFIRMATION PROCEDURE

1. Turn ignition switch ON.
2. Turn ignition switch OFF and wait at least 10 seconds.
3. Turn ignition switch ON.
4. Repeat steps 2 and 3 for 32 times.
5. Check 1st trip DTC.

Is 1st trip DTC detected?

- YES >> Go to [EC-361, "Diagnosis Procedure"](#).
NO >> INSPECTION END

Diagnosis Procedure

INFOID:000000003598158

1. CHECK ELECTRIC THROTTLE CONTROL ACTUATOR VISUALLY

1. Turn ignition switch OFF.
2. Remove the intake air duct.

P1226 TP SENSOR

[VQ35DE]

< COMPONENT DIAGNOSIS >

3. Check if foreign matter is caught between the throttle valve (1) and the housing.
 - Electric throttle control actuator (2)
 - ↵: Vehicle front

Is the inspection result normal?

YES >> GO TO 2.

NO >> Remove the foreign matter and clean the electric throttle control actuator inside.

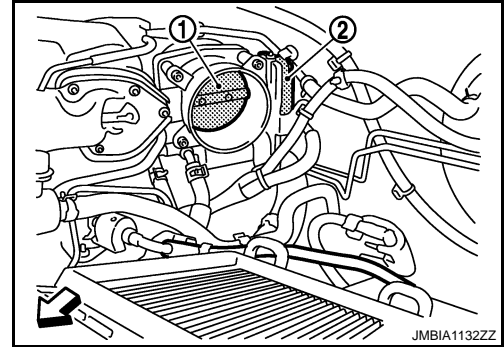

2.REPLACE ELECTRIC THROTTLE CONTROL ACTUATOR

1. Replace electric throttle control actuator.
2. Go to [EC-360. "Special Repair Requirement"](#).

>> INSPECTION END

Special Repair Requirement

INFOID:000000003591589

1.PERFORM THROTTLE VALVE CLOSED POSITION LEARNING

Refer to [EC-17, "THROTTLE VALVE CLOSED POSITION LEARNING : Special Repair Requirement"](#)

>> GO TO 2.

2.PERFORM IDLE AIR VOLUME LEARNING

Refer to [EC-17, "IDLE AIR VOLUME LEARNING : Special Repair Requirement"](#)

>> END

P1421 COLD START CONTROL

< COMPONENT DIAGNOSIS >

[VQ35DE]

P1421 COLD START CONTROL

Description

INFOID:000000003388144

ECM controls ignition timing and engine idle speed when engine is started with pre-warming up condition. This control promotes the activation of three way catalyst by heating the catalyst and reduces emissions.

DTC Logic

INFOID:000000003388145

DTC DETECTION LOGIC

NOTE:

- If DTC P1421 is displayed with other DTC, first perform the trouble diagnosis for other DTC.

DTC No.	Trouble diagnosis name	DTC detecting condition	Possible cause
P1421	Cold start emission reduction strategy monitoring	ECM does not control ignition timing and engine idle speed properly when engine is started with pre-warming up condition.	<ul style="list-style-type: none">• Lack of intake air volume• Fuel injection system• ECM

DTC CONFIRMATION PROCEDURE

1. PRECONDITIONING

If DTC Confirmation Procedure has been previously conducted, always perform the following before conducting the next test.

1. Turn ignition switch OFF and wait at least 10 seconds.
2. Turn ignition switch ON.
3. Turn ignition switch OFF and wait at least 10 seconds.

TESTING CONDITION:

Before performing the following procedure, confirm that battery voltage is more than 11 V at idle.

>> GO TO 2.

2. PERFORM DTC CONFIRMATION PROCEDURE

With CONSULT-III

1. Turn ignition switch ON.
2. Select "DATA MONITOR" mode with CONSULT-III.
3. Check that the "COOLAN TEMP/S" indication is between 4°C (39°F) and 36°C (97°F).
If "COOLAN TEMP/S" indication is within the specified value, go to the following steps.
If "COOLAN TEMP/S" indication is out of the specified value, cool engine down or warm engine up and go to step 1.
4. Start engine and let it idle for 5 minutes.
5. Check 1st trip DTC.

With GST

Follow the procedure "With CONSULT-III" above.

Is 1st trip DTC detected?

- YES >> Go to [EC-363. "Diagnosis Procedure"](#).
NO >> INSPECTION END

Diagnosis Procedure

INFOID:000000003388146

1. PERFORM IDLE AIR VOLUME LEARNING

Perform [EC-17. "IDLE AIR VOLUME LEARNING : Special Repair Requirement"](#).

Is Idle Air Volume Learning carried out successfully?

- YES >> GO TO 2.
NO >> Follow the instruction of Idle Air Volume Learning.

2. CHECK INTAKE SYSTEM

Check for the cause of intake air volume lacking. Refer to the following.

P1421 COLD START CONTROL

[VQ35DE]

< COMPONENT DIAGNOSIS >

- Crushed intake air passage
- Intake air passage clogging

Is the inspection result normal?

YES >> GO TO 3.

NO >> Repair or replace malfunctioning part

3. CHECK FUEL INJECTION SYSTEM FUNCTION

Perform [EC-226. "DTC Logic"](#) for DTC P0171, P0174.

Is the inspection result normal?

YES >> GO TO 4.

NO >> Go to [EC-228. "Diagnosis Procedure"](#) for DTC P0171, P0174.

4. PERFORM DTC CONFIRMATION PROCEDURE

1. Turn ignition switch ON.
2. Erase DTC.
3. Perform DTC CONFIRMATION PROCEDURE.
See [EC-363. "DTC Logic"](#).

Is the 1st trip DTC P1421 displayed again?

YES >> GO TO 5.

NO >> INSPECTION END

5. REPLACE ECM

1. Replace ECM.
2. Go to [EC-15. "ADDITIONAL SERVICE WHEN REPLACING CONTROL UNIT : Special Repair Requirement"](#).

>> INSPECTION END

P1550 BATTERY CURRENT SENSOR

< COMPONENT DIAGNOSIS >

[VQ35DE]

P1550 BATTERY CURRENT SENSOR

Description

INFOID:000000003388147

The power generation voltage variable control enables fuel consumption to be decreased by reducing the engine load which is caused by the power generation of the generator. The battery current sensor is installed to the battery cable at the negative terminal. The sensor measures the charging/discharging current of the battery. Based on the sensor signal, ECM judges whether or not the power generation voltage variable control is performed. When performing the power generation voltage variable control, ECM calculates the target power generation voltage based on the sensor signal. And ECM sends the calculated value as the power generation command value to IPDM E/R. For the details of the power generation voltage variable control, refer to [CHG-7, "System Description"](#).

CAUTION:

Never connect the electrical component or the ground wire directly to the battery terminal. The connection causes the malfunction of the power generation voltage variable control, and then battery discharge may occur.

DTC Logic

INFOID:000000003388148

DTC DETECTION LOGIC

NOTE:

If DTC P1550 is displayed with DTC P0643, first perform the trouble diagnosis for DTC P0643. Refer to [EC-347, "DTC Logic"](#).

DTC No.	Trouble diagnosis name	DTC detecting condition	Possible cause
P1550	Battery current sensor circuit range/performance	The output voltage of the battery current sensor remains within the specified range while engine is running.	<ul style="list-style-type: none">• Harness or connectors (The sensor circuit is open or shorted.)• Battery current sensor

DTC CONFIRMATION PROCEDURE

1. PRECONDITIONING

If DTC Confirmation Procedure has been previously conducted, always perform the following before conducting the next test.

1. Turn ignition switch OFF and wait at least 10 seconds.
2. Turn ignition switch ON.
3. Turn ignition switch OFF and wait at least 10 seconds.

TESTING CONDITION:

Before performing the following procedure, confirm that battery voltage is more than 8 V at idle.

>> GO TO 2.

2. PERFORM DTC CONFIRMATION PROCEDURE

1. Start engine and wait at least 10 seconds.
2. Check 1st trip DTC.

Is 1st trip DTC detected?

- YES >> Go to [EC-365, "Diagnosis Procedure"](#).
NO >> INSPECTION END

Diagnosis Procedure

INFOID:000000003388149

1. CHECK GROUND CONNECTION

1. Turn ignition switch OFF.
2. Check ground connection E38. Refer to Ground Inspection in [GI-43, "Circuit Inspection"](#).

Is the inspection result normal?

- YES >> GO TO 2.
NO >> Repair or replace ground connection.

2. CHECK BATTERY CURRENT SENSOR POWER SUPPLY CIRCUIT

P1550 BATTERY CURRENT SENSOR

[VQ35DE]

< COMPONENT DIAGNOSIS >

1. Disconnect battery current sensor harness connector.
2. Turn ignition switch ON.
3. Check the voltage between battery current sensor harness connector and ground.

Battery current sensor		Ground	Voltage (V)
Connector	Terminal		
F76	1	Ground	Approx. 5

Is the inspection result normal?

YES >> GO TO 3.

NO >> Repair open circuit, short to ground or short to power in harness or connectors.

3.CHECK BATTERY CURRENT SENSOR GROUND CIRCUIT FOR OPEN AND SHORT

1. Turn ignition switch OFF.
2. Disconnect ECM harness connector.
3. Check the continuity between battery current sensor harness connector and ECM harness connector.

Battery current sensor		ECM		Continuity
Connector	Terminal	Connector	Terminal	
F76	2	F8	44	Existed

4. Also check harness for short to ground and short to power.

Is the inspection result normal?

YES >> GO TO 4.

NO >> Repair open circuit, short to ground or short to power in harness or connectors.

4.CHECK BATTERY CURRENT SENSOR INPUT SIGNAL CIRCUIT FOR OPEN AND SHORT

1. Check the continuity between battery current sensor harness connector and ECM harness connector.

Battery current sensor		ECM		Continuity
Connector	Terminal	Connector	Terminal	
F76	3	F8	42	Existed

2. Also check harness for short to ground and short to power.

Is the inspection result normal?

YES >> GO TO 5.

NO >> Repair open circuit, short to ground or short to power in harness or connectors.

5.CHECK BATTERY CURRENT SENSOR

Refer to [EC-366, "Component Inspection"](#).

Is the inspection result normal?

YES >> GO TO 6.

NO >> Replace battery negative cable assembly.

6.CHECK INTERMITTENT INCIDENT

Refer to [GI-40, "Intermittent Incident"](#).

>> INSPECTION END

Component Inspection

INFOID:000000003388150

1.CHECK BATTERY CURRENT SENSOR

1. Turn ignition switch OFF.
2. Reconnect harness connectors disconnected.

P1550 BATTERY CURRENT SENSOR

[VQ35DE]

< COMPONENT DIAGNOSIS >

3. Disconnect battery negative cable (1).
 - ⇐: Vehicle front
 - ←: To body ground
4. Install jumper cable (A) between battery negative terminal and body ground.
5. Turn ignition switch ON.
6. Check the voltage between ECM harness connector terminals under the following conditions.

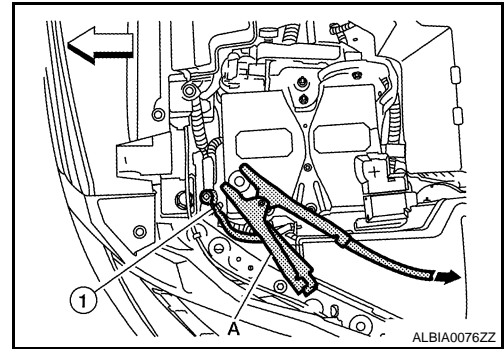

Connector	ECM		Voltage (V)
	+	-	
	Terminal	Terminal	
F8	42 (Battery current sensor signal)	44 (Sensor ground)	Approx. 2.5

Before measuring the terminal voltage, confirm that the battery is fully charged. Refer to [PG-3, "How to Handle Battery"](#).

Is the inspection result normal?

- YES >> INSPECTION END
 NO >> Replace battery negative cable assembly.

A
 EC
 C
 D
 E
 F
 G
 H
 I
 J
 K
 L
 M
 N
 O
 P

P1551, P1552 BATTERY CURRENT SENSOR

< COMPONENT DIAGNOSIS >

[VQ35DE]

P1551, P1552 BATTERY CURRENT SENSOR

Description

INFOID:000000003664590

The power generation voltage variable control enables fuel consumption to be decreased by reducing the engine load which is caused by the power generation of the generator. The battery current sensor is installed to the battery cable at the negative terminal. The sensor measures the charging/discharging current of the battery. Based on the sensor signal, ECM judges whether or not the power generation voltage variable control is performed. When performing the power generation voltage variable control, ECM calculates the target power generation voltage based on the sensor signal. And ECM sends the calculated value as the power generation command value to IPDM E/R. For the details of the power generation voltage variable control, refer to [CHG-7, "System Description"](#).

CAUTION:

Never connect the electrical component or the ground wire directly to the battery terminal. The connection causes the malfunction of the power generation voltage variable control, and then battery discharge may occur.

DTC Logic

INFOID:000000003388152

DTC DETECTION LOGIC

NOTE:

If DTC P1551 or P1552 is displayed with DTC P0643, first perform the trouble diagnosis for DTC P0643. Refer to [EC-347, "DTC Logic"](#).

DTC No.	Trouble diagnosis name	DTC detecting condition	Possible cause
P1551	Battery current sensor circuit low input	An excessively low voltage from the sensor is sent to ECM.	<ul style="list-style-type: none">• Harness or connectors (The sensor circuit is open or shorted.)• Battery current sensor
P1552	Battery current sensor circuit high input	An excessively high voltage from the sensor is sent to ECM.	

DTC CONFIRMATION PROCEDURE

1. PRECONDITIONING

If DTC Confirmation Procedure has been previously conducted, always perform the following before conducting the next test.

1. Turn ignition switch OFF and wait at least 10 seconds.
2. Turn ignition switch ON.
3. Turn ignition switch OFF and wait at least 10 seconds.

TESTING CONDITION:

Before performing the following procedure, confirm that battery voltage is more than 8 V with ignition switch ON

>> GO TO 2.

2. PERFORM DTC CONFIRMATION PROCEDURE

1. Turn ignition switch ON and wait at least 10 seconds.
2. Check 1st trip DTC.

Is 1st trip DTC detected?

- YES >> Go to [EC-368, "Diagnosis Procedure"](#).
NO >> INSPECTION END

Diagnosis Procedure

INFOID:000000003664591

1. CHECK GROUND CONNECTION

1. Turn ignition switch OFF.
2. Check ground connection E38. Refer to Ground Inspection in [GI-43, "Circuit Inspection"](#).

Is the inspection result normal?

- YES >> GO TO 2.

P1551, P1552 BATTERY CURRENT SENSOR

[VQ35DE]

< COMPONENT DIAGNOSIS >

NO >> Repair or replace ground connection.

2.CHECK BATTERY CURRENT SENSOR POWER SUPPLY CIRCUIT

1. Disconnect battery current sensor harness connector.
2. Turn ignition switch ON.
3. Check the voltage between battery current sensor harness connector and ground.

Battery current sensor		Ground	Voltage (V)
Connector	Terminal		
F76	1	Ground	Approx. 5

Is the inspection result normal?

YES >> GO TO 3.

NO >> Repair open circuit, short to ground or short to power in harness or connectors.

3.CHECK BATTERY CURRENT SENSOR GROUND CIRCUIT FOR OPEN AND SHORT

1. Turn ignition switch OFF.
2. Disconnect ECM harness connector.
3. Check the continuity between battery current sensor harness connector and ECM harness connector.

Battery current sensor		ECM		Continuity
Connector	Terminal	Connector	Terminal	
F76	2	F8	44	Existed

4. Also check harness for short to ground and short to power.

Is the inspection result normal?

YES >> GO TO 4.

NO >> Repair open circuit, short to ground or short to power in harness or connectors.

4.CHECK BATTERY CURRENT SENSOR INPUT SIGNAL CIRCUIT FOR OPEN AND SHORT

1. Check the continuity between battery current sensor harness connector and ECM harness connector.

Battery current sensor		ECM		Continuity
Connector	Terminal	Connector	Terminal	
F76	3	F8	42	Existed

2. Also check harness for short to ground and short to power.

Is the inspection result normal?

YES >> GO TO 5.

NO >> Repair open circuit, short to ground or short to power in harness or connectors.

5.CHECK BATTERY CURRENT SENSOR

Refer to [EC-366, "Component Inspection"](#).

Is the inspection result normal?

YES >> GO TO 6.

NO >> Replace battery negative cable assembly.

6.CHECK INTERMITTENT INCIDENT

Refer to [GI-40, "Intermittent Incident"](#).

>> INSPECTION END

Component Inspection

INFOID:000000003635142

1.CHECK BATTERY CURRENT SENSOR

1. Turn ignition switch OFF.
2. Reconnect harness connectors disconnected.

P1551, P1552 BATTERY CURRENT SENSOR

[VQ35DE]

< COMPONENT DIAGNOSIS >

3. Disconnect battery negative cable (1).

⇐ : Vehicle front

➡ : To body ground

4. Install jumper cable (A) between battery negative terminal and body ground.
5. Turn ignition switch ON.
6. Check the voltage between ECM harness connector terminals under the following conditions.

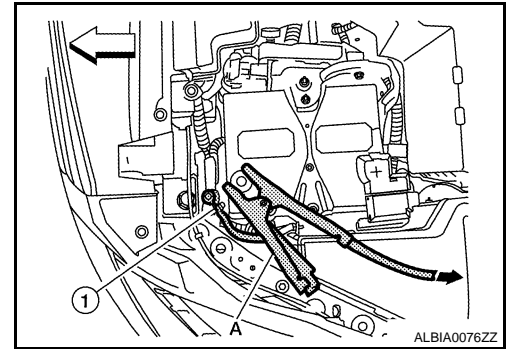

Connector	ECM		Voltage (V)
	+	-	
	Terminal	Terminal	
F8	42 (Battery current sensor signal)	44 (Sensor ground)	Approx. 2.5

Before measuring the terminal voltage, confirm that the battery is fully charged. Refer to [PG-3. "How to Handle Battery"](#).

Is the inspection result normal?

YES >> INSPECTION END

NO >> Replace battery negative cable assembly.

P1553 BATTERY CURRENT SENSOR

< COMPONENT DIAGNOSIS >

[VQ35DE]

P1553 BATTERY CURRENT SENSOR

Description

INFOID:000000003664592

The power generation voltage variable control enables fuel consumption to be decreased by reducing the engine load which is caused by the power generation of the generator. The battery current sensor is installed to the battery cable at the negative terminal. The sensor measures the charging/discharging current of the battery. Based on the sensor signal, ECM judges whether or not the power generation voltage variable control is performed. When performing the power generation voltage variable control, ECM calculates the target power generation voltage based on the sensor signal. And ECM sends the calculated value as the power generation command value to IPDM E/R. For the details of the power generation voltage variable control, refer to [CHG-7, "System Description"](#).

CAUTION:

Never connect the electrical component or the ground wire directly to the battery terminal. The connection causes the malfunction of the power generation voltage variable control, and then battery discharge may occur.

DTC Logic

INFOID:000000003388156

DTC DETECTION LOGIC

NOTE:

If DTC P1553 is displayed with DTC P0643, first perform the trouble diagnosis for DTC P0643. Refer to [EC-347, "DTC Logic"](#).

DTC No.	Trouble diagnosis name	DTC detecting condition	Possible cause
P1553	Battery current sensor performance	The signal voltage transmitted from the sensor to ECM is higher than the amount of the maximum power generation.	<ul style="list-style-type: none">• Harness or connectors (The sensor circuit is open or shorted.)• Battery current sensor

DTC CONFIRMATION PROCEDURE

1. PRECONDITIONING

If DTC Confirmation Procedure has been previously conducted, always perform the following before conducting the next test.

1. Turn ignition switch OFF and wait at least 10 seconds.
2. Turn ignition switch ON.
3. Turn ignition switch OFF and wait at least 10 seconds.

TESTING CONDITION:

Before performing the following procedure, confirm that battery voltage is more than 8 V at idle.

>> GO TO 2.

2. PERFORM DTC CONFIRMATION PROCEDURE

1. Start engine and wait at least 10 seconds.
2. Check 1st trip DTC.

Is 1st trip DTC detected?

- YES >> Go to [EC-371, "Diagnosis Procedure"](#).
NO >> INSPECTION END

Diagnosis Procedure

INFOID:000000003664593

1. CHECK GROUND CONNECTION

1. Turn ignition switch OFF.
2. Check ground connection E38. Refer to Ground Inspection in [GI-43, "Circuit Inspection"](#).

Is the inspection result normal?

- YES >> GO TO 2.
NO >> Repair or replace ground connection.

2. CHECK BATTERY CURRENT SENSOR POWER SUPPLY CIRCUIT

P1553 BATTERY CURRENT SENSOR

[VQ35DE]

< COMPONENT DIAGNOSIS >

1. Disconnect battery current sensor harness connector.
2. Turn ignition switch ON.
3. Check the voltage between battery current sensor harness connector and ground.

Battery current sensor		Ground	Voltage (V)
Connector	Terminal		
F76	1	Ground	Approx. 5

Is the inspection result normal?

YES >> GO TO 3.

NO >> Repair open circuit, short to ground or short to power in harness or connectors.

3.CHECK BATTERY CURRENT SENSOR GROUND CIRCUIT FOR OPEN AND SHORT

1. Turn ignition switch OFF.
2. Disconnect ECM harness connector.
3. Check the continuity between battery current sensor harness connector and ECM harness connector.

Battery current sensor		ECM		Continuity
Connector	Terminal	Connector	Terminal	
F76	2	F8	44	Existed

4. Also check harness for short to ground and short to power.

Is the inspection result normal?

YES >> GO TO 4.

NO >> Repair open circuit, short to ground or short to power in harness or connectors.

4.CHECK BATTERY CURRENT SENSOR INPUT SIGNAL CIRCUIT FOR OPEN AND SHORT

1. Check the continuity between battery current sensor harness connector and ECM harness connector.

Battery current sensor		ECM		Continuity
Connector	Terminal	Connector	Terminal	
F76	3	F8	42	Existed

2. Also check harness for short to ground and short to power.

Is the inspection result normal?

YES >> GO TO 5.

NO >> Repair open circuit, short to ground or short to power in harness or connectors.

5.CHECK BATTERY CURRENT SENSOR

Refer to [EC-366. "Component Inspection"](#).

Is the inspection result normal?

YES >> GO TO 6.

NO >> Replace battery negative cable assembly.

6.CHECK INTERMITTENT INCIDENT

Refer to [GI-40. "Intermittent Incident"](#).

>> INSPECTION END

Component Inspection

INFOID:000000003635141

1.CHECK BATTERY CURRENT SENSOR

1. Turn ignition switch OFF.
2. Reconnect harness connectors disconnected.

P1553 BATTERY CURRENT SENSOR

[VQ35DE]

< COMPONENT DIAGNOSIS >

3. Disconnect battery negative cable (1).

↶ : Vehicle front

➡ : To body ground

4. Install jumper cable (A) between battery negative terminal and body ground.
5. Turn ignition switch ON.
6. Check the voltage between ECM harness connector terminals under the following conditions.

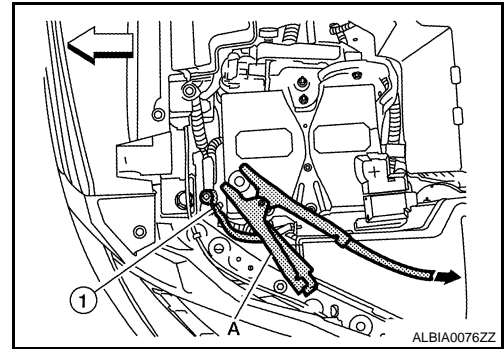

Connector	ECM		Voltage (V)
	+	-	
	Terminal	Terminal	
F8	42 (Battery current sensor signal)	44 (Sensor ground)	Approx. 2.5

Before measuring the terminal voltage, confirm that the battery is fully charged. Refer to [PG-3, "How to Handle Battery"](#).

Is the inspection result normal?

YES >> INSPECTION END

NO >> Replace battery negative cable assembly.

A
EC
C
D
E
F
G
H
I
J
K
L
M
N
O
P

P1554 BATTERY CURRENT SENSOR

< COMPONENT DIAGNOSIS >

[VQ35DE]

P1554 BATTERY CURRENT SENSOR

Description

INFOID:000000003664588

The power generation voltage variable control enables fuel consumption to be decreased by reducing the engine load which is caused by the power generation of the generator. The battery current sensor is installed to the battery cable at the negative terminal. The sensor measures the charging/discharging current of the battery. Based on the sensor signal, ECM judges whether or not the power generation voltage variable control is performed. When performing the power generation voltage variable control, ECM calculates the target power generation voltage based on the sensor signal. And ECM sends the calculated value as the power generation command value to IPDM E/R. For the details of the power generation voltage variable control, refer to [CHG-7, "System Description"](#).

CAUTION:

Never connect the electrical component or the ground wire directly to the battery terminal. The connection causes the malfunction of the power generation voltage variable control, and then battery discharge may occur.

DTC Logic

INFOID:000000003388160

DTC DETECTION LOGIC

NOTE:

If DTC P1554 is displayed with DTC P0643, first perform the trouble diagnosis for DTC P0643. Refer to [EC-347, "DTC Logic"](#).

DTC No.	Trouble diagnosis name	DTC detecting condition	Possible cause
P1554	Battery current sensor performance	The output voltage of the battery current sensor is lower than the specified value while the battery voltage is high enough.	<ul style="list-style-type: none">• Harness or connectors (The sensor circuit is open or shorted.)• Battery current sensor

DTC CONFIRMATION PROCEDURE

1.PERFORM COMPONENT FUNCTION CHECK

Perform component function check. Refer to [EC-374, "Component Function Check"](#).

NOTE:

Use component function check to check the overall function of the battery current sensor circuit. During this check, a 1st trip DTC might not be confirmed.

Is the inspection result normal?

YES >> INSPECTION END

NO >> Go to [EC-375, "Diagnosis Procedure"](#).

Component Function Check

INFOID:000000003388161

1.PRECONDITIONING

TESTING CONDITION:

- Before performing the following procedure, confirm that battery voltage is more than 12.8 V at idle.
- Before performing the following procedure, confirm that all load switches and A/C switch are turned OFF.

>> GO TO 2.

2.PERFORM COMPONENT FUNCTION CHECK

With CONSULT-III

1. Start engine and let it idle.
2. Select "BAT CUR SEN" in "DATA MONITOR" mode with CONSULT-III.
3. Check "BAT CUR SEN" indication for 10 seconds.
"BAT CUR SEN" should be above 2,300mV at least once.

Without CONSULT-III

1. Start engine and let it idle.
2. Check voltage between ECM harness connector terminals under the following conditions.

P1554 BATTERY CURRENT SENSOR

< COMPONENT DIAGNOSIS >

[VQ35DE]

Connector	ECM		Voltage (V)
	+	-	
	Terminal	Terminal	
F8	42 (Battery current sensor signal)	44 (Sensor ground)	Above 2.3 at least once

Is the inspection result normal?

- YES >> INSPECTION END
 NO >> Go to [EC-375. "Diagnosis Procedure"](#)

Diagnosis Procedure

INFOID:000000003591747

1. CHECK GROUND CONNECTION

- Turn ignition switch OFF.
- Check ground connection E38. Refer to Ground Inspection in [GI-43. "Circuit Inspection"](#).

Is the inspection result normal?

- YES >> GO TO 2.
 NO >> Repair or replace ground connection.

2. CHECK BATTERY CURRENT SENSOR POWER SUPPLY CIRCUIT

- Disconnect battery current sensor harness connector.
- Turn ignition switch ON.
- Check the voltage between battery current sensor harness connector and ground.

Battery current sensor		Ground	Voltage (V)
Connector	Terminal		
F76	1	Ground	Approx. 5

Is the inspection result normal?

- YES >> GO TO 3.
 NO >> Repair open circuit, short to ground or short to power in harness or connectors.

3. CHECK BATTERY CURRENT SENSOR GROUND CIRCUIT FOR OPEN AND SHORT

- Turn ignition switch OFF.
- Disconnect ECM harness connector.
- Check the continuity between battery current sensor harness connector and ECM harness connector.

Battery current sensor		ECM		Continuity
Connector	Terminal	Connector	Terminal	
F76	2	F8	44	Existed

- Also check harness for short to ground and short to power.

Is the inspection result normal?

- YES >> GO TO 4.
 NO >> Repair open circuit, short to ground or short to power in harness or connectors.

4. CHECK BATTERY CURRENT SENSOR INPUT SIGNAL CIRCUIT FOR OPEN AND SHORT

- Check the continuity between battery current sensor harness connector and ECM harness connector.

Battery current sensor		ECM		Continuity
Connector	Terminal	Connector	Terminal	
F76	3	F8	42	Existed

- Also check harness for short to ground and short to power.

Is the inspection result normal?

P1554 BATTERY CURRENT SENSOR

[VQ35DE]

< COMPONENT DIAGNOSIS >

- YES >> GO TO 5.
- NO >> Repair open circuit, short to ground or short to power in harness or connectors.

5.CHECK BATTERY CURRENT SENSOR

Refer to [EC-376. "Component Inspection"](#).

Is the inspection result normal?

- YES >> GO TO 6.
- NO >> Replace battery negative cable assembly.

6.CHECK INTERMITTENT INCIDENT

Refer to [GI-40. "Intermittent Incident"](#).

>> INSPECTION END

Component Inspection

INFOID:000000003664589

1.CHECK BATTERY CURRENT SENSOR

1. Turn ignition switch OFF.
2. Reconnect harness connectors disconnected.
3. Disconnect battery negative cable (1).
 - ↶: Vehicle front
 - ↠: To body ground
4. Install jumper cable (A) between battery negative terminal and body ground.
5. Turn ignition switch ON.
6. Check the voltage between ECM harness connector terminals under the following conditions.

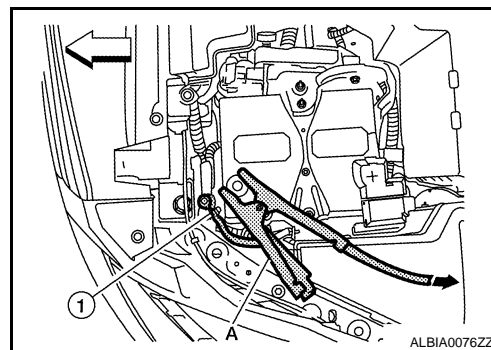

Connector	ECM		Voltage (V)
	+	-	
	Terminal	Terminal	
F8	42 (Battery current sensor signal)	44 (Sensor ground)	Approx. 2.5

Before measuring the terminal voltage, confirm that the battery is fully charged. Refer to [PG-3. "How to Handle Battery"](#).

Is the inspection result normal?

- YES >> INSPECTION END
- NO >> Replace battery negative cable assembly.

P1564 ASCD STEERING SWITCH

< COMPONENT DIAGNOSIS >

[VQ35DE]

P1564 ASCD STEERING SWITCH

Description

INFOID:000000003388164

ASCD steering switch has variant values of electrical resistance for each button. ECM reads voltage variation of switch, and determines which button is operated. Refer to [EC-51, "System Diagram"](#) for the ASCD function.

DTC Logic

INFOID:000000003388165

DTC DETECTION LOGIC

NOTE:

If DTC P1564 is displayed with DTC P0605, first perform the trouble diagnosis for DTC P0605. Refer to [EC-344, "DTC Logic"](#).

DTC No.	Trouble diagnosis name	DTC detecting condition	Possible cause
P1564	ASCD steering switch	<ul style="list-style-type: none">An excessively high voltage signal from the ASCD steering switch is sent to ECM.ECM detects that input signal from the ASCD steering switch is out of the specified range.ECM detects that the ASCD steering switch is stuck ON.	<ul style="list-style-type: none">Harness or connectors (The switch circuit is open or shorted.)ASCD steering switchECM

DTC CONFIRMATION PROCEDURE

1. PRECONDITIONING

If DTC Confirmation Procedure has been previously conducted, always perform the following before conducting the next test.

- Turn ignition switch OFF and wait at least 10 seconds.
- Turn ignition switch ON.
- Turn ignition switch OFF and wait at least 10 seconds.

>> GO TO 2.

2. PERFORM DTC CONFIRMATION PROCEDURE

- Turn ignition switch ON and wait at least 10 seconds.
- Press MAIN switch for at least 10 seconds, then release it and wait at least 10 seconds.
- Press CANCEL switch for at least 10 seconds, then release it and wait at least 10 seconds.
- Press RESUME/ACCELERATE switch for at least 10 seconds, then release it and wait at least 10 seconds.
- Press SET/COAST switch for at least 10 seconds, then release it and wait at least 10 seconds.
- Check DTC.

Is DTC detected?

- YES >> Go to [EC-377, "Diagnosis Procedure"](#).
NO >> INSPECTION END

Diagnosis Procedure

INFOID:000000003388166

1. CHECK GROUND CONNECTION

- Turn ignition switch OFF.
- Check ground connection E38. Refer to Ground Inspection in [GI-43, "Circuit Inspection"](#).

Is the inspection result normal?

- YES >> GO TO 2.
NO >> Repair or replace ground connection.

2. CHECK ASCD STEERING SWITCH CIRCUIT

 With CONSULT-III

P1564 ASCD STEERING SWITCH

[VQ35DE]

< COMPONENT DIAGNOSIS >

1. Turn ignition switch ON.
2. Select "MAIN SW", "CANCEL SW", "RESUME/ACC SW" and "SET SW" in "DATA MONITOR" mode with CONSULT-III.
3. Check each item indication under the following conditions.

Monitor item	Condition		Indication
MAIN SW	MAIN switch	Pressed	ON
		Released	OFF
CANCEL SW	CANCEL switch	Pressed	ON
		Released	OFF
RESUME/ACC SW	RESUME/ACCELERATE switch	Pressed	ON
		Released	OFF
SET SW	SET/COAST switch	Pressed	ON
		Released	OFF

⊗ Without CONSULT-III

1. Turn ignition switch ON.
2. Check the voltage between ECM harness connector terminals under the following conditions.

ECM			Condition	Voltage (V)
Con- nector	+	-		
	Terminal	Terminal		
E16	85 (ASCD steering switch signal)	92 (ASCD steering switch ground)	MAIN switch: Pressed	Approx. 0
			CANCEL switch: Pressed	Approx. 1
			SET/COAST switch: Pressed	Approx. 2
			RESUME/ACCELERATE switch: Pressed	Approx. 3
			All ASCD steering switches: Released	Approx. 4

Is the inspection result normal?

- YES >> GO TO 8.
NO >> GO TO 3.

3. CHECK ASCD STEERING SWITCH GROUND CIRCUIT FOR OPEN AND SHORT

1. Turn ignition switch OFF.
2. Disconnect ECM harness connector.
3. Disconnect combination switch harness connector.
4. Check the continuity between combination switch and ECM harness connector.

Combination switch	ECM		Continuity
	Terminal	Connector	
16	E16	92	Existed

5. Also check harness for short to ground and short to power.

Is the inspection result normal?

- YES >> GO TO 5.
NO >> GO TO 4.

4. DETECT MALFUNCTIONING PART

Check the following.

- Harness connectors M77, E105
- Combination switch (spiral cable)
- Harness for open and short between ECM and combination switch

>> Repair open circuit, short to ground or short to power in harness or connectors.

P1564 ASCD STEERING SWITCH

[VQ35DE]

< COMPONENT DIAGNOSIS >

5. CHECK ASCD STEERING SWITCH INPUT SIGNAL CIRCUIT FOR OPEN AND SHORT

1. Check the continuity between combination switch and ECM harness connector.

Combination switch		ECM		Continuity
Terminal	Connector	Terminal		
13	E16	85		Existed

2. Also check harness for short to ground and short to power.

Is the inspection result normal?

YES >> GO TO 7.

NO >> GO TO 6.

6. DETECT MALFUNCTIONING PART

Check the following.

- Harness connectors M77, E105
- Combination switch (spiral cable)
- Harness for open and short between ECM and combination switch

>> Repair open circuit, short to ground or short to power in harness or connectors.

7. CHECK ASCD STEERING SWITCH

Refer to [EC-379, "Component Inspection"](#).

Is the inspection result normal?

YES >> GO TO 8.

NO >> Replace ASCD steering switch.

8. CHECK INTERMITTENT INCIDENT

Refer to [GI-40, "Intermittent Incident"](#).

>> **INSPECTION END**

Component Inspection

INFOID:000000003388167

1. CHECK ASCD STEERING SWITCH

1. Turn ignition switch OFF.
2. Disconnect combination switch (spiral cable) harness connector.
3. Check resistance between combination switch harness connector terminals as per the following.

Combination switch		Condition	Resistance (Ω)
Connector	Terminals		
M33	13 and 16	MAIN switch: Pressed	Approx. 0
		CANCEL switch: Pressed	Approx. 250
		SET/COAST switch: Pressed	Approx. 660
		RESUME/ACCELERATE switch: Pressed	Approx. 1,480
		All ASCD steering switches: Released	Approx. 4,000

Is the inspection result normal?

YES >> INSPECTION END

NO >> Replace ASCD steering switch

P1572 ASCD BRAKE SWITCH

< COMPONENT DIAGNOSIS >

[VQ35DE]

P1572 ASCD BRAKE SWITCH

Description

INFOID:000000003388168

When the brake pedal is depressed, ASCD brake switch is turned OFF and stop lamp switch is turned ON. ECM detects the state of the brake pedal by those two types of input (ON/OFF signal). Refer to [EC-51, "System Diagram"](#) for the ASCD function.

DTC Logic

INFOID:000000003388169

DTC DETECTION LOGIC

NOTE:

- If DTC P1572 is displayed with DTC P0605, first perform the trouble diagnosis for DTC P0605. Refer to [EC-344, "DTC Logic"](#).
- This self-diagnosis has the one trip detection logic. When malfunction A is detected, DTC is not stored in ECM memory. And in that case, 1st trip DTC and 1st trip freeze frame data are displayed. 1st trip DTC is erased when ignition switch is turned OFF. And even when malfunction A is detected in two consecutive trips, DTC is not stored in ECM memory.

DTC No.	Trouble diagnosis name	DTC detecting condition		Possible cause
P1572	ASCD brake switch	A)	When the vehicle speed is above 30 km/h (19 MPH), ON signals from the stop lamp switch and the ASCD brake switch are sent to the ECM at the same time.	<ul style="list-style-type: none">• Harness or connectors (The stop lamp switch circuit is shorted.)• Harness or connectors (The ASCD brake switch circuit is shorted.)• Stop lamp switch• ASCD brake switch• Incorrect stop lamp switch installation• Incorrect ASCD brake switch installation• ECM
		B)	ASCD brake switch signal is not sent to ECM for extremely long time while the vehicle is being driven.	

DTC CONFIRMATION PROCEDURE

1. PRECONDITIONING

If DTC Confirmation Procedure has been previously conducted, always perform the following before conducting the next test.

1. Turn ignition switch OFF and wait at least 10 seconds.
2. Turn ignition switch ON.
3. Turn ignition switch OFF and wait at least 10 seconds.

NOTE:

The procedure for malfunction B is not described. It takes extremely long time to complete the procedure for malfunction B. By performing the procedure for malfunction A, the condition that causes malfunction B can be detected.

>> GO TO 2.

2. PERFORM DTC CONFIRMATION PROCEDURE

With CONSULT-III

1. Start engine (VDC switch OFF).
2. Select "DATA MONITOR" mode with CONSULT-III.
3. Press MAIN switch and check that CRUISE illuminates.
4. Drive the vehicle for at least 5 consecutive seconds under the following conditions.

CAUTION:

Always drive vehicle at a safe speed.

NOTE:

This procedure may be conducted with the drive wheels lifted in the shop or by driving the vehicle. If a road test is expected to be easier, it is unnecessary to lift the vehicle.

VHCL SPEED SE	More than 30 km/h (19 mph)
Selector lever	Suitable position

P1572 ASCD BRAKE SWITCH

[VQ35DE]

< COMPONENT DIAGNOSIS >

5. Check 1st trip DTC.

With GST

Follow the procedure "With CONSULT-III" above.

Is 1st trip DTC detected?

- YES >> Go to [EC-381, "Diagnosis Procedure"](#).
- NO >> GO TO 3.

3.PERFORM DTC CONFIRMATION PROCEDURE

With CONSULT-III

1. Drive the vehicle for at least 5 consecutive seconds under the following conditions.

CAUTION:

Always drive vehicle at a safe speed.

NOTE:

This procedure may be conducted with the drive wheels lifted in the shop or by driving the vehicle. If a road test is expected to be easier, it is unnecessary to lift the vehicle.

VHCL SPEED SE	More than 30 km/h (19 mph)
Selector lever	Suitable position
Driving location	Depress the brake pedal for more than five seconds so as not to come off from the above-mentioned vehicle speed.

2. Check 1st trip DTC.

With GST

Follow the procedure "With CONSULT-III" above.

Is 1st trip DTC detected?

- YES >> Go to [EC-381, "Diagnosis Procedure"](#).
- NO >> INSPECTION END

Diagnosis Procedure

INFOID:000000003388170

1.CHECK OVERALL FUNCTION-I

With CONSULT-III

1. Turn ignition switch ON.
2. Select "BRAKE SW1" in "DATA MONITOR" mode with CONSULT-III.
3. Check "BRAKE SW1" indication under the following conditions.

Monitor item	Condition		Indication
BRAKE SW1	Brake pedal	Slightly depressed	OFF
		Fully released	ON

Without CONSULT-III

1. Turn ignition switch ON.
2. Check the voltage between ECM harness connector terminals.

Connector	ECM		Condition	Voltage
	+	-		
	Terminal	Terminal		
E16	110 (ASCD brake switch signal)	112	Brake pedal Slightly depressed	Approx. 0 V
			Brake pedal Fully released	Battery voltage

Is the inspection result normal?

- YES >> GO TO 2.
- NO >> GO TO 3.

P1572 ASCD BRAKE SWITCH

[VQ35DE]

< COMPONENT DIAGNOSIS >

2. CHECK OVERALL FUNCTION-II

With CONSULT-III

Check "BRAKE SW2" indication in "DATA MONITOR" mode.

Monitor item	Condition		Indication
BRAKE SW2	Brake pedal	Slightly depressed	ON
		Fully released	OFF

Without CONSULT-III

Check the voltage between ECM harness connector terminals.

Connector	ECM		Condition	Voltage	
	+	-			
	Terminal	Terminal			
E16	106 (Stop lamp switch signal)	112	Brake pedal	Slightly depressed	Battery voltage
			Fully released	Approx. 0 V	

Is the inspection result normal?

YES >> GO TO 12.

NO >> GO TO 7.

3. CHECK ASCD BRAKE SWITCH POWER SUPPLY CIRCUIT

1. Turn ignition switch OFF.
2. Disconnect ASCD brake switch harness connector.
3. Turn ignition switch ON.
4. Check the voltage between ASCD brake switch harness connector and ground.

ASCD brake switch		Ground	Voltage
Connector	Terminal		
E49	1	Ground	Battery voltage

Is the inspection result normal?

YES >> GO TO 5.

NO >> GO TO 4.

4. DETECT MALFUNCTIONING PART

Check the following.

- Fuse block (J/B) connector E103
- 10 A fuse (No. 3)
- Harness for open or short between ASCD brake switch and fuse

>> Repair open circuit, short to ground or short to power in harness or connectors.

5. CHECK ASCD BRAKE SWITCH INPUT SIGNAL CIRCUIT FOR OPEN AND SHORT

1. Turn ignition switch OFF.
2. Disconnect ECM harness connector.
3. Check the continuity between ASCD brake switch harness connector and ECM harness connector.

ASCD brake switch		ECM		Continuity
Connector	Terminal	Connector	Terminal	
E49	2	E16	110	Existed

4. Also check harness for short to ground and short to power.

Is the inspection result normal?

P1572 ASCD BRAKE SWITCH

[VQ35DE]

< COMPONENT DIAGNOSIS >

- YES >> GO TO 6.
NO >> Repair open circuit, short to ground or short to power in harness or connectors.

6.CHECK ASCD BRAKE SWITCH

Refer to [EC-384. "Component Inspection \(ASCD Brake Switch\)"](#)

Is the inspection result normal?

- YES >> GO TO 12.
NO >> Replace ASCD brake switch.

7.CHECK STOP LAMP SWITCH POWER SUPPLY CIRCUIT

1. Turn ignition switch OFF.
2. Disconnect stop lamp switch harness connector.
3. Check the voltage between stop lamp switch harness connector and ground.

Vehicle serial number	Stop lamp switch		Ground	Voltage
	Connector	Terminal		
Up to JN8AZ18U*9W100000	E115	3	Ground	Battery voltage
Up to JN8AZ18U*9W710000				
Up to JN8AZ18W*9W200000				
Up to JN8AZ18W*9W810000				
From JN8AZ18U*9W100001	E116	1		
From JN8AZ18U*9W710001				
From JN8AZ18W*9W200001				
From JN8AZ18W*9W810001				

Is the inspection result normal?

- YES >> GO TO 9.
NO >> GO TO 8.

8.DETECT MALFUNCTIONING PART

Check the following.

- Fuse block (J/B) connector E103
- 10 A fuse (No. 7)
- Harness for open or short between stop lamp switch and battery

>> Repair open circuit, short to ground or short to power in harness or connectors.

9.CHECK STOP LAMP SWITCH INPUT SIGNAL CIRCUIT FOR OPEN AND SHORT

1. Disconnect ECM harness connector.
2. Check the continuity between stop lamp switch harness connector and ECM harness connector.

Vehicle serial number	Stop lamp switch		ECM		Continuity
	Connector	Terminal	Connector	Terminal	
Up to JN8AZ18U*9W100000	E115	4	E16	106	Existed
Up to JN8AZ18U*9W710000					
Up to JN8AZ18W*9W200000					
Up to JN8AZ18W*9W810000					
From JN8AZ18U*9W100001	E116	2			
From JN8AZ18U*9W710001					
From JN8AZ18W*9W200001					
From JN8AZ18W*9W810001					

3. Also check harness for short to ground and short to power.

Is the inspection result normal?

P1572 ASCD BRAKE SWITCH

[VQ35DE]

< COMPONENT DIAGNOSIS >

- YES >> GO TO 11.
- NO >> GO TO 10.

10. DETECT MALFUNCTIONING PART

Check the following.

- Fuse block (J/B) connector E103
- Harness for open or short between stop lamp switch and ECM

>> Repair open circuit, short to ground or short to power in harness or connectors.

11. CHECK STOP LAMP SWITCH

Refer to [EC-384, "Component Inspection \(Stop Lamp Switch\)"](#)

Is the inspection result normal?

- YES >> GO TO 12.
- NO >> Replace stop lamp switch.

12. CHECK INTERMITTENT INCIDENT

Refer to [GI-40, "Intermittent Incident"](#).

>> INSPECTION END

Component Inspection (ASCD Brake Switch)

INFOID:000000003388171

1. CHECK ASCD BRAKE SWITCH-I

1. Turn ignition switch OFF.
2. Disconnect ASCD brake switch harness connector.
3. Check the continuity between ASCD brake switch terminals under the following conditions.

Terminals	Condition		Continuity
1 and 2	Brake pedal	Fully released	Existed
		Slightly depressed	Not existed

Is the inspection result normal?

- YES >> INSPECTION END
- NO >> GO TO 2.

2. CHECK ASCD BRAKE SWITCH-II

1. Adjust ASCD brake switch installation. Refer to [BR-9, "Inspection and Adjustment"](#).
2. Check the continuity between ASCD brake switch terminals under the following conditions.

Terminals	Condition		Continuity
1 and 2	Brake pedal	Fully released	Existed
		Slightly depressed	Not existed

Is the inspection result normal?

- YES >> INSPECTION END
- NO >> Replace ASCD brake switch.

Component Inspection (Stop Lamp Switch)

INFOID:000000003388173

1. CHECK STOP LAMP SWITCH-I

1. Turn ignition switch OFF.
2. Disconnect stop lamp switch harness connector.
3. Check harness continuity between stop lamp switch terminals under the following conditions.

P1572 ASCD BRAKE SWITCH

< COMPONENT DIAGNOSIS >

[VQ35DE]

Vehicle serial number	Terminals	Condition	Continuity	
Up to JN8AZ18U*9W100000	3 and 4	Brake pedal	Fully released	Not existed
Up to JN8AZ18U*9W710000			Slightly depressed	Existed
Up to JN8AZ18W*9W200000				
Up to JN8AZ18W*9W810000				
From JN8AZ18U*9W100001	1 and 2	Brake pedal	Fully released	Not existed
From JN8AZ18U*9W710001			Slightly depressed	Existed
From JN8AZ18W*9W200001				
From JN8AZ18W*9W810001				

Is the inspection result normal?

YES >> INSPECTION END

NO >> GO TO 2.

2. CHECK STOP LAMP SWITCH-II

- Adjust stop lamp switch installation. Refer to [BR-9. "Inspection and Adjustment"](#).
- Check harness continuity between stop lamp switch terminals under the following conditions.

Vehicle serial number	Terminals	Condition	Continuity	
Up to JN8AZ18U*9W100000	3 and 4	Brake pedal	Fully released	Not existed
Up to JN8AZ18U*9W710000			Slightly depressed	Existed
Up to JN8AZ18W*9W200000				
Up to JN8AZ18W*9W810000				
From JN8AZ18U*9W100001	1 and 2	Brake pedal	Fully released	Not existed
From JN8AZ18U*9W710001			Slightly depressed	Existed
From JN8AZ18W*9W200001				
From JN8AZ18W*9W810001				

Is the inspection result normal?

YES >> INSPECTION END

NO >> Replace stop lamp switch.

A
EC
C
D
E
F
G
H
I
J
K
L
M
N
O
P

P1574 ASCD VEHICLE SPEED SENSOR

[VQ35DE]

< COMPONENT DIAGNOSIS >

P1574 ASCD VEHICLE SPEED SENSOR

Description

INFOID:000000003388174

The ECM receives two vehicle speed signals via CAN communication line. One is sent from combination meter, and the other is from TCM (Transmission control module). The ECM uses these signals for ASCD control. Refer to [EC-51, "System Diagram"](#) for ASCD functions.

DTC Logic

INFOID:000000003388175

DTC DETECTION LOGIC

NOTE:

- If DTC P1574 is displayed with DTC UXXXX, first perform the trouble diagnosis for DTC UXXXX.
- If DTC P1574 is displayed with DTC P0500, first perform the trouble diagnosis for DTC P0500. Refer to [EC-333, "DTC Logic"](#).
- If DTC P1574 is displayed with DTC P0605, first perform the trouble diagnosis for DTC P0605. Refer to [EC-344, "DTC Logic"](#).
- If DTC P1574 is displayed with DTC P0607, first perform the trouble diagnosis for DTC P0607. Refer to [EC-346, "DTC Logic"](#).

DTC No.	Trouble diagnosis name	DTC detecting condition	Possible cause
P1574	ASCD vehicle speed sensor	The difference the between two vehicle speed signals is out of the specified range.	<ul style="list-style-type: none">• Harness or connectors (The CAN communication line is open or shorted.)• Combination meter• ABS actuator and electric unit (control unit)• Wheel sensor• TCM• ECM

DTC CONFIRMATION PROCEDURE

1. PRECONDITIONING

If DTC Confirmation Procedure has been previously conducted, always perform the following before conducting the next test.

1. Turn ignition switch OFF and wait at least 10 seconds.
2. Turn ignition switch ON.
3. Turn ignition switch OFF and wait at least 10 seconds.

>> GO TO 2.

2. PERFORM DTC CONFIRMATION PROCEDURE

1. Start engine (VDC switch OFF).
2. Drive the vehicle at more than 40 km/h (25 MPH).

CAUTION:

Always drive vehicle at a safe speed.

NOTE:

This procedure may be conducted with the drive wheels lifted in the shop or by driving the vehicle.

If a road test is expected to be easier, it is unnecessary to lift the vehicle.

3. Check DTC.

Is DTC detected?

- YES >> Go to [EC-386, "Diagnosis Procedure"](#).
NO >> INSPECTION END

Diagnosis Procedure

INFOID:000000003388176

1. CHECK DTC WITH TCM

Check DTC with TCM. Refer to [TM-32, "Diagnosis Description"](#).

Is the inspection result normal?

P1574 ASCD VEHICLE SPEED SENSOR

[VQ35DE]

< COMPONENT DIAGNOSIS >

- YES >> GO TO 2.
- NO >> Perform trouble shooting relevant to DTC indicated.

A

2.CHECK DTC WITH "ABS ACTUATOR AND ELECTRIC UNIT (CONTROL UNIT)"

Refer to [BRC-29. "CONSULT-III Function"](#).

Is the inspection result normal?

- YES >> GO TO 3.
- NO >> Repair or replace malfunctioning part.

EC

C

3.CHECK COMBINATION METER FUNCTION

Refer to [MWI-34. "CONSULT-III Function \(METER/M&A\)"](#).

D

>> INSPECTION END

E

F

G

H

I

J

K

L

M

N

O

P

P1700 CVT CONTROL SYSTEM

< COMPONENT DIAGNOSIS >

[VQ35DE]

P1700 CVT CONTROL SYSTEM

Description

INFOID:000000003388177

This DTC is displayed with other DTC regarding TCM. Perform the trouble diagnosis for corresponding DTC. Refer to [EC-521, "DTC Index"](#). When this DTC is detected, the ASCD control is canceled.

P1715 INPUT SPEED SENSOR (PRIMARY SPEED SENSOR)

< COMPONENT DIAGNOSIS >

[VQ35DE]

P1715 INPUT SPEED SENSOR (PRIMARY SPEED SENSOR)

Description

INFOID:000000003388178

ECM receives primary speed sensor signal from TCM via the CAN communication line. ECM uses this signal for engine control.

DTC Logic

INFOID:000000003388179

DTC DETECTION LOGIC

NOTE:

- If DTC P1715 is displayed with DTC UXXXX first perform the trouble diagnosis for DTC UXXXX.
- If DTC P1715 is displayed with DTC P0335, first perform the trouble diagnosis for DTC P0335. Refer to [EC-260, "DTC Logic"](#).
- If DTC P1715 is displayed with DTC P0340, P0345, first perform the trouble diagnosis for DTC P0340, P0345. Refer to [EC-264, "DTC Logic"](#).
- If DTC P1715 is displayed with DTC P0605, first perform the trouble diagnosis for DTC P0605. Refer to [EC-344, "DTC Logic"](#).
- If DTC P1715 is displayed with DTC P0607, first perform the trouble diagnosis for DTC P0607. Refer to [EC-346, "DTC Logic"](#).

DTC No.	Trouble diagnosis name	DTC detecting condition	Possible cause
P1715	Input speed sensor (Primary speed sensor) (TCM output)	Primary speed sensor signal is different from the theoretical value calculated by ECM from secondary sensor signal and engine rpm signal.	<ul style="list-style-type: none">• Harness or connectors (The CAN communication line is open or shorted)• Harness or connectors (Primary speed sensor circuit is open or shorted)• TCM

DTC CONFIRMATION PROCEDURE

1. PRECONDITIONING

If DTC Confirmation Procedure has been previously conducted, always perform the following before conducting the next test.

1. Turn ignition switch OFF and wait at least 10 seconds.
2. Turn ignition switch ON.
3. Turn ignition switch OFF and wait at least 10 seconds.

>> GO TO 2.

2. PERFORM DTC CONFIRMATION PROCEDURE

1. Start engine.
2. Drive vehicle at a speed of more than 50 km/h (31 MPH) for at least 5 seconds.
3. Check 1st trip DTC.

Is 1st trip DTC detected?

- YES >> Go to [EC-389, "Diagnosis Procedure"](#).
NO >> INSPECTION END

Diagnosis Procedure

INFOID:000000003388180

1. CHECK DTC WITH TCM

Check DTC with TCM. Refer to [TM-129, "DTC Index"](#).

Is the inspection result normal?

- YES >> GO TO 2.
NO >> Perform trouble shooting relevant to DTC indicated.

2. REPLACE TCM

Replace TCM. Refer to [TM-163, "Removal and Installation"](#).

P1715 INPUT SPEED SENSOR (PRIMARY SPEED SENSOR)

< COMPONENT DIAGNOSIS >

[VQ35DE]

>> INSPECTION END

P1720 VSS

Description

INFOID:000000003388181

ECM receives two vehicle speed signals via the CAN communication line. One is sent from “ABS actuator and electric unit (control unit)” via combination meter, and the other is from TCM (Transmission control module). ECM uses these signals for engine control.

DTC Logic

INFOID:000000003388182

DTC DETECTION LOGIC

NOTE:

- If DTC P1720 is displayed with DTC UXXXX first perform the trouble diagnosis for DTC UXXXX.
- If DTC P1720 is displayed with DTC P0607, first perform the trouble diagnosis for DTC P0607. Refer to [EC-346, "DTC Logic"](#).

DTC No.	Trouble diagnosis name	DTC detecting condition	Possible cause
P1720	Vehicle speed sensor (TCM output)	The difference between two vehicle speed signals is out of the specified range.	<ul style="list-style-type: none"> • Harness or connectors (Secondary speed sensor circuit is open or shorted.) • Harness or connectors (Wheel sensor circuit is open or shorted.) • TCM • Secondary speed sensor • ABS actuator and electric unit (control unit) • Wheel sensor • Combination meter

DTC CONFIRMATION PROCEDURE

1. PRECONDITIONING

If DTC Confirmation Procedure has been previously conducted, always perform the following before conducting the next test.

1. Turn ignition switch OFF and wait at least 10 seconds.
2. Turn ignition switch ON.
3. Turn ignition switch OFF and wait at least 10 seconds.

>> GO TO 2.

2. PERFORM DTC CONFIRMATION PROCEDURE

1. Start engine.
2. Drive vehicle at a speed of 20 km/h (12 MPH) or more for at least 5 seconds without depressing the brake pedal depressing.
3. Check 1st trip DTC.

Is 1st trip DTC detected?

- YES >> Go to [EC-391, "Diagnosis Procedure"](#).
- NO >> INSPECTION END

Diagnosis Procedure

INFOID:000000003388183

1. CHECK DTC WITH TCM

Check DTC with TCM. Refer to [TM-129, "DTC Index"](#).

Is the inspection result normal?

- YES >> GO TO 2.
- NO >> Perform trouble shooting relevant to DTC indicated.

2. CHECK DTC WITH “ABS ACTUATOR AND ELECTRIC UNIT (CONTROL UNIT)”

Refer to [BRC-102, "DTC No. Index"](#).

Is the inspection result normal?

P1720 VSS

[VQ35DE]

< COMPONENT DIAGNOSIS >

YES >> GO TO 3.

NO >> perform trouble shooting relevant to DTC indicated.

3.CHECK COMBINATION METER FUNCTION

Refer to [MWI-75. "DTC Index"](#).

>> INSPECTION END

P1800 VIAS CONTROL SOLENOID VALVE 1

< COMPONENT DIAGNOSIS >

[VQ35DE]

P1800 VIAS CONTROL SOLENOID VALVE 1

Description

INFOID:000000003388184

The VIAS control solenoid valve 1 cuts the intake manifold vacuum signal for power valve 1 control. It responds to ON/OFF signals from the ECM. When the solenoid is OFF, the vacuum signal from the intake manifold is cut. When the ECM sends an ON signal the coil pulls the plunger downward and sends the vacuum signal to the power valve actuator 1.

DTC Logic

INFOID:000000003388185

DTC DETECTION LOGIC

DTC No.	Trouble diagnosis name	DTC detecting condition	Possible cause
P1800	VIAS control solenoid valve 1 circuit	An excessively low or high voltage signal is sent to ECM through the VIAS control solenoid valve 1.	<ul style="list-style-type: none"> • Harness or connectors (The solenoid valve 1 circuit is open or shorted.) • VIAS control solenoid valve 1

DTC CONFIRMATION PROCEDURE

1.CONDITIONING

If DTC Confirmation Procedure has been previously conducted, always perform the following before conducting the next test.

1. Turn ignition switch OFF and wait at least 10 seconds.
2. Turn ignition switch ON.
3. Turn ignition switch OFF and wait at least 10 seconds.

TESTING CONDITION:

Before performing the following procedure, confirm battery voltage is more than 11 V at idle.

>> GO TO 2.

2.PERFORM DTC CONFIRMATION PROCEDURE

1. Start engine and let it idle for at least 5 seconds.
2. Check 1st trip DTC.

Is 1st trip DTC detected?

- YES >> Go to [EC-393, "Diagnosis Procedure"](#).
- NO >> INSPECTION END

Diagnosis Procedure

INFOID:000000003388186

1.CHECK VIAS CONTROL SOLENOID VALVE 1 POWER SUPPLY CIRCUIT

1. Turn ignition switch OFF.
2. Disconnect VIAS control solenoid valve 1 harness connector.
3. Turn ignition switch ON.
4. Check the voltage between VIAS control solenoid valve 1 harness connector and ground.

VIAS control solenoid valve 1		Ground	Voltage
Connector	Terminal		
F74	1	Ground	Battery voltage

Is the inspection result normal?

- YES >> GO TO 2.
- NO >> Repair open circuit, short to ground or short to power in harness or connectors.

2.CHECK VIAS CONTROL SOLENOID VALVE 1 OUTPUT SIGNAL CIRCUIT FOR OPEN AND SHORT

1. Turn ignition switch OFF.
2. Disconnect ECM harness connector.

P1800 VIAS CONTROL SOLENOID VALVE 1

[VQ35DE]

< COMPONENT DIAGNOSIS >

- Check the continuity between VIAS control solenoid valve 1 harness connector and ECM harness connector.

VIAS control solenoid valve 1		ECM		Continuity
Connector	Terminal	Connector	Terminal	
F74	2	F7	27	Existed

- Also check harness for short to ground and short to power.

Is the inspection result normal?

YES >> GO TO 3.

NO >> Repair open circuit, short to ground or short to power in harness or connectors.

3.CHECK VIAS CONTROL SOLENOID VALVE 1

Refer to [EC-394, "Component Inspection"](#).

Is the inspection result normal?

YES >> GO TO 4.

NO >> Replace VIAS control solenoid valve 1.

4.CHECK INTERMITTENT INCIDENT

Refer to [GI-40, "Intermittent Incident"](#).

>> INSPECTION END

Component Inspection

INFOID:000000003388187

1.CHECK VIAS CONTROL SOLENOID VALVE 1

With CONSULT-III

- Turn ignition switch OFF.
- Reconnect all harness connectors disconnected.
- Disconnect vacuum hoses connected to VIAS control solenoid valve 1.
- Turn ignition switch ON.
- Select "VIAS S/V-1" in "ACTIVE TEST" mode with CONSULT-III.
- Check air passage continuity and operation delay time under the following conditions.

Condition (VIAS S/V-1)	Air passage continuity between (A) and (B)	Air passage continuity between (A) and (C)
ON	Existed	Not existed
OFF	Not existed	Existed

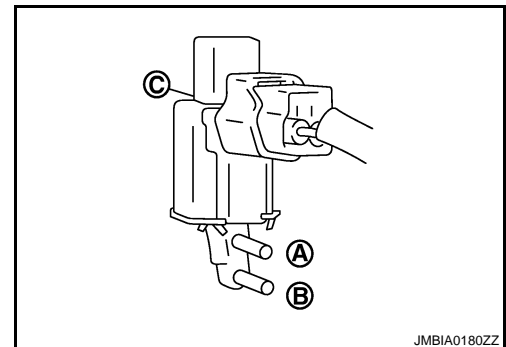

Without CONSULT-III

- Turn ignition switch OFF.
- Disconnect VIAS control solenoid valve 1 harness connector.
- Disconnect vacuum hoses connected to VIAS volume control solenoid valve 1.

P1800 VIAS CONTROL SOLENOID VALVE 1

[VQ35DE]

< COMPONENT DIAGNOSIS >

4. Check air passage continuity and operation delay time under the following conditions.

Condition	Air passage continuity between (A) and (B)	Air passage continuity between (A) and (C)
12 V direct current supply between terminals 1 and 2	Existed	Not existed
No supply	Not existed	Existed

Is the inspection result normal?

- YES >> INSPECTION END
 NO >> Replace VIAS control solenoid valve 1

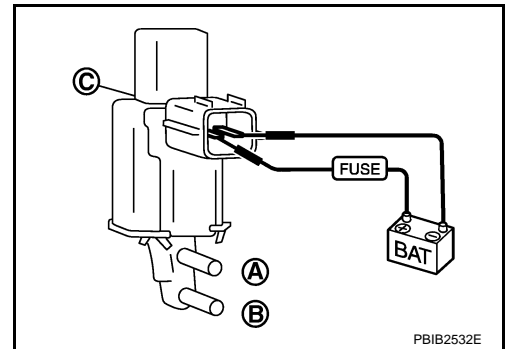

A
 EC
 C
 D
 E
 F
 G
 H
 I
 J
 K
 L
 M
 N
 O
 P

P1801 VIAS CONTROL SOLENOID VALVE 2

< COMPONENT DIAGNOSIS >

[VQ35DE]

P1801 VIAS CONTROL SOLENOID VALVE 2

Description

INFOID:000000003388188

The VIAS control solenoid valve 2 cuts the intake manifold vacuum signal for power valve 2 control. It responds to ON/OFF signals from the ECM. When the solenoid is OFF, the vacuum signal from the intake manifold is cut. When the ECM sends an ON signal the coil pulls the plunger downward and sends the vacuum signal to the power valve actuator 2.

DTC Logic

INFOID:000000003388189

DTC DETECTION LOGIC

DTC No.	Trouble diagnosis name	DTC detecting condition	Possible cause
P1801	VIAS control solenoid valve 2 circuit	An excessively low or high voltage signal is sent to ECM through the VIAS control solenoid valve 2.	<ul style="list-style-type: none"> • Harness or connectors (The solenoid valve 2 circuit is open or shorted.) • VIAS control solenoid valve 2

DTC CONFIRMATION PROCEDURE

1.CONDITIONING

If DTC Confirmation Procedure has been previously conducted, always perform the following before conducting the next test.

1. Turn ignition switch OFF and wait at least 10 seconds.
2. Turn ignition switch ON.
3. Turn ignition switch OFF and wait at least 10 seconds.

TESTING CONDITION:

Before performing the following procedure, confirm battery voltage is more than 11 V at idle.

>> GO TO 2.

2.PERFORM DTC CONFIRMATION PROCEDURE

1. Start engine and let it idle for at least 5 seconds.
2. Check 1st trip DTC.

Is 1st trip DTC detected?

- YES >> Go to [EC-396, "Diagnosis Procedure"](#).
- NO >> INSPECTION END

Diagnosis Procedure

INFOID:000000003388190

1.CHECK VIAS CONTROL SOLENOID VALVE 2 POWER SUPPLY CIRCUIT

1. Turn ignition switch OFF.
2. Disconnect VIAS control solenoid valve 2 harness connector.
3. Turn ignition switch ON.
4. Check the voltage between VIAS control solenoid valve 2 harness connector and ground.

VIAS control solenoid valve 2		Ground	Voltage
Connector	Terminal		
F75	1	Ground	Battery voltage

Is the inspection result normal?

- YES >> GO TO 2.
- NO >> Repair open circuit, short to ground or short to power in harness or connectors.

2.CHECK VIAS CONTROL SOLENOID VALVE 2 OUTPUT SIGNAL CIRCUIT FOR OPEN AND SHORT

1. Turn ignition switch OFF.
2. Disconnect ECM harness connector.

P1801 VIAS CONTROL SOLENOID VALVE 2

[VQ35DE]

< COMPONENT DIAGNOSIS >

3. Check the continuity between VIAS control solenoid valve 2 harness connector and ECM harness connector.

VIAS control solenoid valve 2		ECM		Continuity
Connector	Terminal	Connector	Terminal	
F75	2	F7	26	Existed

4. Also check harness for short to ground and short to power.

Is the inspection result normal?

YES >> GO TO 3.

NO >> Repair open circuit, short to ground or short to power in harness or connectors.

3.CHECK VIAS CONTROL SOLENOID VALVE 2

Refer to [EC-397, "Component Inspection"](#).

Is the inspection result normal?

YES >> GO TO 4.

NO >> Replace VIAS control solenoid valve 2.

4.CHECK INTERMITTENT INCIDENT

Refer to [GI-40, "Intermittent Incident"](#).

>> INSPECTION END

Component Inspection

INFOID:000000003388191

1.CHECK VIAS CONTROL SOLENOID VALVE 2

With CONSULT-III

1. Turn ignition switch OFF.
2. Reconnect all harness connectors disconnected.
3. Disconnect vacuum hoses connected to VIAS control solenoid valve 2.
4. Turn ignition switch ON.
5. Select "VIAS S/V-2" in "ACTIVE TEST" mode with CONSULT-III.
6. Check air passage continuity and operation delay time under the following conditions.

Condition (VIAS S/V-2)	Air passage continuity between (A) and (B)	Air passage continuity between (A) and (C)
ON	Existed	Not existed
OFF	Not existed	Existed

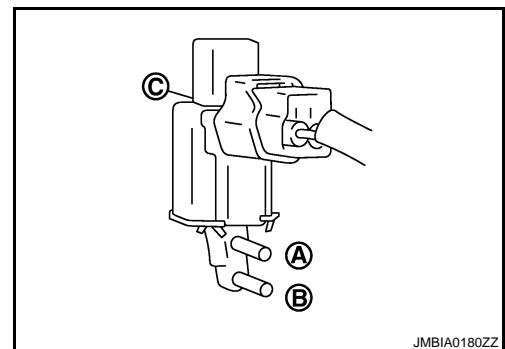

Without CONSULT-III

1. Turn ignition switch OFF.
2. Disconnect VIAS control solenoid valve 2 harness connector.
3. Disconnect vacuum hoses connected to VIAS volume control solenoid valve 2.

P1801 VIAS CONTROL SOLENOID VALVE 2

[VQ35DE]

< COMPONENT DIAGNOSIS >

4. Check air passage continuity and operation delay time under the following conditions.

Condition	Air passage continuity between (A) and (B)	Air passage continuity between (A) and (C)
12 V direct current supply between terminals 1 and 2	Existed	Not existed
No supply	Not existed	Existed

Is the inspection result normal?

YES >> INSPECTION END

NO >> Replace VIAS control solenoid valve 2

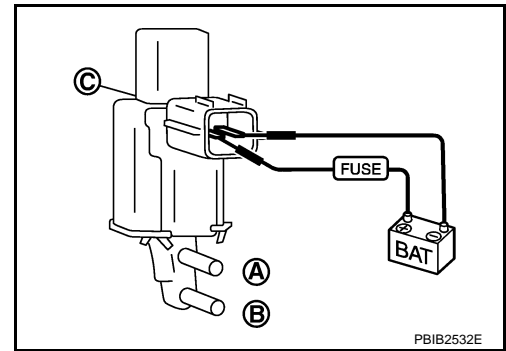

P1805 BRAKE SWITCH

< COMPONENT DIAGNOSIS >

[VQ35DE]

P1805 BRAKE SWITCH

Description

INFOID:000000003388192

Brake switch signal is applied to the ECM through the stop lamp switch when the brake pedal is depressed. This signal is used mainly to decrease the engine speed when the vehicle is being driven.

DTC Logic

INFOID:000000003388193

DTC DETECTION LOGIC

DTC No.	Trouble diagnosis name	DTC detecting condition	Possible cause
P1805	Brake switch	A brake switch signal is not sent to ECM for extremely long time while the vehicle is being driven.	<ul style="list-style-type: none">• Harness or connectors (Stop lamp switch circuit is open or shorted.)• Stop lamp switch

DTC CONFIRMATION PROCEDURE

1. PERFORM DTC CONFIRMATION PROCEDURE

1. Turn ignition switch ON.
2. Fully depress the brake pedal for at least 5 seconds.
3. Erase the DTC.
4. Check 1st trip DTC.

Is 1st trip DTC detected?

YES >> Go to [EC-399, "Diagnosis Procedure"](#).

NO >> INSPECTION END

Diagnosis Procedure

INFOID:000000003388194

1. CHECK STOP LAMP SWITCH CIRCUIT

1. Turn ignition switch OFF.
2. Check the stop lamp when depressing and releasing the brake pedal.

Brake pedal	Stop lamp
Fully released	Not illuminated
Slightly depressed	Illuminated

Is the inspection result normal?

YES >> GO TO 4.

NO >> GO TO 2.

2. CHECK STOP LAMP SWITCH POWER SUPPLY CIRCUIT

1. Disconnect stop lamp switch harness connector.
2. Check the voltage between stop lamp switch harness connector and ground.

P1805 BRAKE SWITCH

[VQ35DE]

< COMPONENT DIAGNOSIS >

Vehicle serial number	Stop lamp switch		Ground	Voltage
	Connector	Terminal		
Up to JN8AZ18U*9W100000	E115	3	Ground	Battery voltage
Up to JN8AZ18U*9W710000				
Up to JN8AZ18W*9W200000				
Up to JN8AZ18W*9W810000				
From JN8AZ18U*9W100001	E116	1		
From JN8AZ18U*9W710001				
From JN8AZ18W*9W200001				
From JN8AZ18W*9W810001				

Is the inspection result normal?

YES >> GO TO 4.

NO >> GO TO 3.

3.DETECT MALFUNCTIONING PART

Check the following.

- Fuse block (J/B) connector E103
- 10 A fuse (No. 7)
- Harness for open or short between battery and stop lamp switch

>> Repair open circuit, short to ground or short to power in harness or connectors.

4.CHECK STOP LAMP SWITCH INPUT SIGNAL CIRCUIT FOR OPEN AND SHORT

1. Disconnect stop lamp switch harness connector.
2. Disconnect ECM harness connector.
3. Check the continuity between stop lamp switch harness connector and ECM harness connector.

Vehicle serial number	Stop lamp switch		ECM		Continuity
	Connector	Terminal	Connector	Terminal	
Up to JN8AZ18U*9W100000	E115	4	E16	106	Existed
Up to JN8AZ18U*9W710000					
Up to JN8AZ18W*9W200000					
Up to JN8AZ18W*9W810000					
From JN8AZ18U*9W100001	E116	2			
From JN8AZ18U*9W710001					
From JN8AZ18W*9W200001					
From JN8AZ18W*9W810001					

4. Also check harness for short to ground and short to power.

Is the inspection result normal?

YES >> GO TO 6.

NO >> GO TO 5.

5.DETECT MALFUNCTIONING PART

Check the following.

- Fuse block (J/B) connector E103
- Harness for open or short between ECM and stop lamp switch

>> Repair open circuit, short to ground or short to power in harness or connectors.

6.CHECK STOP LAMP SWITCH

Refer to [EC-401, "Component Inspection \(Stop Lamp Switch\)"](#).

P1805 BRAKE SWITCH

[VQ35DE]

< COMPONENT DIAGNOSIS >

Is the inspection result normal?

- YES >> GO TO 7.
- NO >> Replace stop lamp switch.

7.CHECK INTERMITTENT INCIDENT

Refer to [GI-40. "Intermittent Incident"](#).

>> INSPECTION END

Component Inspection (Stop Lamp Switch)

INFOID:000000003591766

1.CHECK STOP LAMP SWITCH-I

1. Turn ignition switch OFF.
2. Disconnect stop lamp switch harness connector.
3. Check harness continuity between stop lamp switch terminals under the following conditions.

Vehicle serial number	Terminals	Condition	Continuity		
Up to JN8AZ18U*9W100000	3 and 4	Brake pedal	Fully released	Not existed	
Up to JN8AZ18U*9W710000			Slightly depressed	Existed	
Up to JN8AZ18W*9W200000			1 and 2	Fully released	Not existed
Up to JN8AZ18W*9W810000				Slightly depressed	Existed
From JN8AZ18U*9W100001	Brake pedal	Fully released		Not existed	
From JN8AZ18U*9W710001		Slightly depressed	Existed		
From JN8AZ18W*9W200001		1 and 2	Fully released	Not existed	
From JN8AZ18W*9W810001			Slightly depressed	Existed	

Is the inspection result normal?

- YES >> INSPECTION END
- NO >> GO TO 2.

2.CHECK STOP LAMP SWITCH-II

1. Adjust stop lamp switch installation. Refer to [BR-9. "Inspection and Adjustment"](#).
2. Check harness continuity between stop lamp switch terminals under the following conditions.

Vehicle serial number	Terminals	Condition	Continuity		
Up to JN8AZ18U*9W100000	3 and 4	Brake pedal	Fully released	Not existed	
Up to JN8AZ18U*9W710000			Slightly depressed	Existed	
Up to JN8AZ18W*9W200000			1 and 2	Fully released	Not existed
Up to JN8AZ18W*9W810000				Slightly depressed	Existed
From JN8AZ18U*9W100001	Brake pedal	Fully released		Not existed	
From JN8AZ18U*9W710001		Slightly depressed	Existed		
From JN8AZ18W*9W200001		1 and 2	Fully released	Not existed	
From JN8AZ18W*9W810001			Slightly depressed	Existed	

Is the inspection result normal?

- YES >> INSPECTION END
- NO >> Replace stop lamp switch.

P2100, P2103 THROTTLE CONTROL MOTOR RELAY

< COMPONENT DIAGNOSIS >

[VQ35DE]

P2100, P2103 THROTTLE CONTROL MOTOR RELAY

Description

INFOID:000000003388196

Power supply for the throttle control motor is provided to the ECM via throttle control motor relay. The throttle control motor relay is controlled ON/OFF by the ECM. When the ignition switch is turned ON, the ECM sends an ON signal to throttle control motor relay and battery voltage is provided to the ECM. When the ignition switch is turned OFF, the ECM sends an OFF signal to throttle control motor relay and battery voltage is not provided to the ECM.

DTC Logic

INFOID:000000003388197

DTC DETECTION LOGIC

DTC No.	Trouble diagnosis name	DTC detecting condition	Possible cause
P2100	Throttle control motor relay circuit open	ECM detects that the voltage of power source for throttle control motor is excessively low.	<ul style="list-style-type: none">• Harness or connectors (Throttle control motor relay circuit is open)• Throttle control motor relay
P2103	Throttle control motor relay circuit short	ECM detects that the throttle control motor relay is stuck ON.	<ul style="list-style-type: none">• Harness or connectors (Throttle control motor relay circuit is shorted)• Throttle control motor relay

DTC CONFIRMATION PROCEDURE

1. PRECONDITIONING

If DTC Confirmation Procedure has been previously conducted, always perform the following before conducting the next test.

1. Turn ignition switch OFF and wait at least 10 seconds.
2. Turn ignition switch ON.
3. Turn ignition switch OFF and wait at least 10 seconds.

TESTING CONDITION:

Before performing the following procedure, confirm that battery voltage is more than 8 V.

With DTC is detected?

- P2100 >> GO TO 2.
- P2103 >> GO TO 3.

2. PERFORM DTC CONFIRMATION PROCEDURE FOR DTC P2100

1. Turn ignition switch ON and wait at least 2 seconds.
2. Start engine and let it idle for 5 seconds.
3. Check DTC.

Is DTC detected?

- YES >> Go to [EC-402, "Diagnosis Procedure"](#).
- NO >> INSPECTION END

3. PERFORM DTC CONFIRMATION PROCEDURE FOR DTC P2103

1. Turn ignition switch ON and wait at least 1 second.
2. Check DTC.

Is DTC detected?

- YES >> Go to [EC-402, "Diagnosis Procedure"](#).
- NO >> INSPECTION END

Diagnosis Procedure

INFOID:000000003388198

1. CHECK THROTTLE CONTROL MOTOR RELAY POWER SUPPLY CIRCUIT

1. Turn ignition switch OFF.
2. Disconnect ECM harness connector.

P2100, P2103 THROTTLE CONTROL MOTOR RELAY

[VQ35DE]

< COMPONENT DIAGNOSIS >

3. Disconnect IPDM E/R harness connector.
4. Check the continuity between IPDM E/R harness connector and ECM harness connector.

A

IPDM E/R		ECM		Continuity
Connector	Terminal	Connector	Terminal	
F12	70	F7	15	Existed

EC

5. Also check harness for short to ground and short to power.

C

Is the inspection result normal?

YES >> GO TO 2.

NO >> Repair open circuit, short to ground or short to power in harness or connectors.

D

2.CHECK THROTTLE CONTROL MOTOR RELAY INPUT SIGNAL CIRCUIT-II

1. Check the continuity between IPDM E/R harness connector and ECM harness connector.

E

IPDM E/R		ECM		Continuity
Connector	Terminal	Connector	Terminal	
F12	54	F7	2	Existed

F

2. Also check harness for short to ground and short to power.

Is the inspection result normal?

G

YES >> GO TO 3.

NO >> Repair open circuit, short to ground or short to power in harness or connectors.

H

3.CHECK FUSE

1. Disconnect 15 A fuse (No. 51) from IPDM E/R.
2. Check if 15 A fuse is blown.

Is the inspection result normal?

I

YES >> GO TO 4.

NO >> Replace 15 A fuse.

J

4.CHECK INTERMITTENT INCIDENT

Refer to [GI-40. "Intermittent Incident"](#).

Is the inspection result normal?

K

YES >> Replace IPDM E/R.

NO >> Repair or replace harness or connectors.

L

M

N

O

P

P2101 ELECTRIC THROTTLE CONTROL FUNCTION

< COMPONENT DIAGNOSIS >

[VQ35DE]

P2101 ELECTRIC THROTTLE CONTROL FUNCTION

Description

INFOID:000000003388199

Electric throttle control actuator consists of throttle control motor, throttle position sensor, etc. The throttle control motor is operated by the ECM and it opens and closes the throttle valve. The current opening angle of the throttle valve is detected by the throttle position sensor. The throttle position sensor provides feedback to the ECM, when opens/closes the throttle valve in response to driving conditions via the throttle control motor.

DTC Logic

INFOID:000000003388200

DTC DETECTION LOGIC

NOTE:

If DTC P2101 is displayed with DTC P2100, first perform the trouble diagnosis for DTC P2100. Refer to [EC-402, "DTC Logic"](#).

If DTC P2101 is displayed with DTC 2119, first perform the trouble diagnosis for DTC P2119. Refer to [EC-411, "DTC Logic"](#).

DTC No.	Trouble diagnosis name	DTC detecting condition	Possible cause
P2101	Electric throttle control performance	Electric throttle control function does not operate properly.	<ul style="list-style-type: none">• Harness or connectors (Throttle control motor circuit is open or shorted)• Electric throttle control actuator

DTC CONFIRMATION PROCEDURE

1. PRECONDITIONING

If DTC Confirmation Procedure has been previously conducted, always perform the following before conducting the next test.

1. Turn ignition switch OFF and wait at least 10 seconds.
2. Turn ignition switch ON.
3. Turn ignition switch OFF and wait at least 10 seconds.

TESTING CONDITION:

Before performing the following procedure, confirm that battery voltage is more than 11 V when engine is running.

>> GO TO 2.

2. PERFORM DTC CONFIRMATION PROCEDURE

1. Turn ignition switch ON and wait at least 2 seconds.
2. Start engine and let it idle for 5 seconds.
3. Check DTC.

Is DTC detected?

- YES >> Go to [EC-404, "Diagnosis Procedure"](#).
NO >> INSPECTION END

Diagnosis Procedure

INFOID:000000003388201

1. CHECK GROUND CONNECTION

1. Turn ignition switch OFF.
2. Check ground connection E38. Refer to Ground Inspection in [GI-43, "Circuit Inspection"](#).

Is the inspection result normal?

- YES >> GO TO 2.
NO >> Repair or replace ground connection.

2. CHECK THROTTLE CONTROL MOTOR RELAY INPUT SIGNAL CIRCUIT-I

1. Check the voltage between ECM harness connector terminals.

P2101 ELECTRIC THROTTLE CONTROL FUNCTION

< COMPONENT DIAGNOSIS >

[VQ35DE]

ECM				Condition	Voltage
+		-			
Connector	Terminal	Condition	Terminal		
F7	2	E16	112	Ignition switch OFF	Approx. 0 V
				Ignition switch ON	Battery voltage

Is the inspection result normal?

- YES >> GO TO 7.
NO >> GO TO 3.

3.CHECK THROTTLE CONTROL MOTOR RELAY POWER SUPPLY CIRCUIT-II

1. Turn ignition switch OFF.
2. Disconnect ECM harness connector.
3. Disconnect IPDM E/R harness connector.
4. Check the continuity between IPDM E/R harness connector and ECM harness connector.

IPDM E/R		ECM		Continuity
Connector	Terminal	Connector	Terminal	
F12	70	F7	15	Existed

5. Also check harness for short to ground and short to power.

Is the inspection result normal?

- YES >> GO TO 4.
NO >> Repair open circuit, short to ground or short to power in harness or connectors.

4.CHECK THROTTLE CONTROL MOTOR RELAY INPUT SIGNAL CIRCUIT-II

1. Check the continuity between IPDM E/R harness connector and ECM harness connector.

IPDM E/R		ECM		Continuity
Connector	Terminal	Connector	Terminal	
F12	54	F7	2	Existed

2. Also check harness for short to ground and short to power.

Is the inspection result normal?

- YES >> GO TO 5.
NO >> Repair open circuit, short to ground or short to power in harness or connectors.

5.CHECK FUSE

1. Disconnect 15 A fuse (No. 51) from IPDM E/R.
2. Check if 15 A fuse is blown.

Is the inspection result normal?

- YES >> GO TO 6.
NO >> Replace 15 A fuse.

6.CHECK INTERMITTENT INCIDENT

Refer to [GI-40, "Intermittent Incident"](#).

Is the inspection result normal?

- YES >> Replace IPDM E/R.
NO >> Repair or replace harness or connectors.

7.CHECK THROTTLE CONTROL MOTOR OUTPUT SIGNAL CIRCUIT FOR OPEN OR SHORT

1. Turn ignition switch OFF.
2. Disconnect electric throttle control actuator harness connector.
3. Disconnect ECM harness connector.
4. Check the continuity between electric throttle control actuator harness connector and ECM harness connector.

P2101 ELECTRIC THROTTLE CONTROL FUNCTION

< COMPONENT DIAGNOSIS >

[VQ35DE]

Electric throttle control actuator		ECM		Continuity
Connector	Terminal	Connector	Terminal	
F29	5	F7	5	Not existed
			6	Existed
	6		5	Existed
			6	Not existed

5. Also check harness for short to ground and short to power.

Is the inspection result normal?

YES >> GO TO 8.

NO >> Repair or replace malfunctioning part.

8. CHECK ELECTRIC THROTTLE CONTROL ACTUATOR VISUALLY

- Remove the intake air duct.
- Check if foreign matter is caught between the throttle valve (1) and the housing.
 - Electric throttle control actuator (2)
 - ↶: Vehicle front

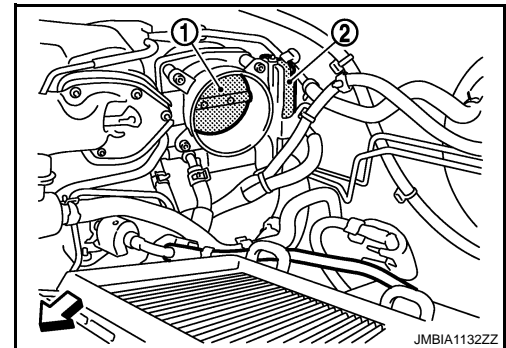

Is the inspection result normal?

YES >> GO TO 9.

NO >> Remove the foreign matter and clean the electric throttle control actuator inside.

9. CHECK THROTTLE CONTROL MOTOR

Refer to [EC-406, "Component Inspection"](#).

Is the inspection result normal?

YES >> GO TO 10.

NO >> GO TO 11.

10. CHECK INTERMITTENT INCIDENT

Refer to [GI-40, "Intermittent Incident"](#).

Is the inspection result normal?

YES >> GO TO 11.

NO >> Repair or replace harness or connectors.

11. REPLACE ELECTRIC THROTTLE CONTROL ACTUATOR

- Replace electric throttle control actuator.
- Refer to [EC-407, "Special Repair Requirement"](#).

>> INSPECTION END

Component Inspection

INFOID:000000003388202

1. CHECK THROTTLE CONTROL MOTOR

- Turn ignition switch OFF.
- Disconnect electric throttle control actuator harness connector.
- Check resistance between electric throttle control actuator terminals as per the following.

Terminals	Resistance
5 and 6	Approx. 1 - 15 Ω [at 25°C (77°F)]

Is the inspection result normal?

P2101 ELECTRIC THROTTLE CONTROL FUNCTION

[VQ35DE]

< COMPONENT DIAGNOSIS >

- YES >> INSPECTION END
- NO >> GO TO 2.

A

2. REPLACE ELECTRIC THROTTLE CONTROL ACTUATOR

1. Replace electric throttle control actuator.
2. Go to [EC-407, "Special Repair Requirement"](#).

EC

>> INSPECTION END

C

Special Repair Requirement

INFOID:000000003388203

1. PERFORM THROTTLE VALVE CLOSED POSITION LEARNING

D

Refer to [EC-17, "THROTTLE VALVE CLOSED POSITION LEARNING : Special Repair Requirement"](#)

>> GO TO 2.

E

2. PERFORM IDLE AIR VOLUME LEARNING

Refer to [EC-17, "IDLE AIR VOLUME LEARNING : Special Repair Requirement"](#)

F

>> END

G

H

I

J

K

L

M

N

O

P

P2118 THROTTLE CONTROL MOTOR

< COMPONENT DIAGNOSIS >

[VQ35DE]

P2118 THROTTLE CONTROL MOTOR

Description

INFOID:000000003388204

The throttle control motor is operated by the ECM and it opens and closes the throttle valve. The current opening angle of the throttle valve is detected by the throttle position sensor. The throttle position sensor provides feedback to the ECM, when opens/closes the throttle valve in response to driving conditions via the throttle control motor.

DTC Logic

INFOID:000000003388205

DTC DETECTION LOGIC

DTC No.	Trouble diagnosis name	DTC detecting condition	Possible cause
P2118	Throttle control motor circuit short	ECM detects short in both circuits between ECM and throttle control motor.	<ul style="list-style-type: none">• Harness or connectors (Throttle control motor circuit is shorted.)• Electric throttle control actuator (Throttle control motor)

DTC CONFIRMATION PROCEDURE

1. PRECONDITIONING

If DTC Confirmation Procedure has been previously conducted, always perform the following before conducting the next test.

1. Turn ignition switch OFF and wait at least 10 seconds.
2. Turn ignition switch ON.
3. Turn ignition switch OFF and wait at least 10 seconds.

>> GO TO 2.

2. PERFORM DTC CONFIRMATION PROCEDURE

1. Turn ignition switch ON and wait at least 2 seconds.
2. Start engine and let it idle for 5 seconds.
3. Check DTC.

Is DTC detected?

- YES >> Go to [EC-408, "Diagnosis Procedure"](#).
NO >> INSPECTION END

Diagnosis Procedure

INFOID:000000003388206

1. CHECK GROUND CONNECTIONS

1. Turn ignition switch OFF.
2. Check ground connection E38. Refer to Ground Inspection in [GI-43, "Circuit Inspection"](#).

Is the inspection result normal?

- YES >> GO TO 2.
NO >> Repair or replace ground connections.

2. CHECK THROTTLE CONTROL MOTOR OUTPUT SIGNAL CIRCUIT FOR OPEN AND SHORT

1. Disconnect electric throttle control actuator harness connector.
2. Disconnect ECM harness connector.
3. Check the continuity between electric throttle control actuator harness connector and ECM harness connector.

P2118 THROTTLE CONTROL MOTOR

< COMPONENT DIAGNOSIS >

[VQ35DE]

Electric throttle control actuator		ECM		Continuity
Connector	Terminal	Connector	Terminal	
F29	5	F7	5	Not existed
			6	Existed
	6		5	Existed
			6	Not existed

4. Also check harness for short to ground and short to power.

Is the inspection result normal?

YES >> GO TO 3.

NO >> Repair or replace malfunctioning part.

3.CHECK THROTTLE CONTROL MOTOR

Refer to [EC-409, "Component Inspection"](#).

Is the inspection result normal?

YES >> GO TO 4.

NO >> GO TO 5.

4.CHECK INTERMITTENT INCIDENT

Refer to [GI-40, "Intermittent Incident"](#).

Is the inspection result normal?

YES >> GO TO 5.

NO >> Repair or replace harness or connectors.

5.REPLACE ELECTRIC THROTTLE CONTROL ACTUATOR

1. Replace electric throttle control actuator.
2. Go to [EC-409, "Special Repair Requirement"](#).

>> INSPECTION END

Component Inspection

INFOID:000000003591712

1.CHECK THROTTLE CONTROL MOTOR

1. Turn ignition switch OFF.
2. Disconnect electric throttle control actuator harness connector.
3. Check resistance between electric throttle control actuator terminals as per the following.

Terminals	Resistance
5 and 6	Approx. 1 - 15 Ω [at 25°C (77°F)]

Is the inspection result normal?

YES >> INSPECTION END

NO >> GO TO 2.

2.REPLACE ELECTRIC THROTTLE CONTROL ACTUATOR

1. Replace electric throttle control actuator.
2. Go to [EC-407, "Special Repair Requirement"](#).

>> INSPECTION END

Special Repair Requirement

INFOID:000000003388208

1.PERFORM THROTTLE VALVE CLOSED POSITION LEARNING

Refer to [EC-17, "THROTTLE VALVE CLOSED POSITION LEARNING : Special Repair Requirement"](#)

P2118 THROTTLE CONTROL MOTOR

< COMPONENT DIAGNOSIS >

[VQ35DE]

>> GO TO 2.

2.PERFORM IDLE AIR VOLUME LEARNING

Refer to [EC-17, "IDLE AIR VOLUME LEARNING : Special Repair Requirement"](#)

>> END

P2119 ELECTRIC THROTTLE CONTROL ACTUATOR

< COMPONENT DIAGNOSIS >

[VQ35DE]

P2119 ELECTRIC THROTTLE CONTROL ACTUATOR

Description

INFOID:000000003388209

Electric throttle control actuator consists of throttle control motor, throttle position sensor, etc. The throttle control motor is operated by the ECM and it opens and closes the throttle valve. The throttle position sensor detects the throttle valve position, and the opening and closing speed of the throttle valve and sends the voltage signals to the ECM. The ECM judges the current opening angle of the throttle valve from these signals and opens/closes the throttle valve in response to driving conditions via the throttle control motor.

DTC Logic

INFOID:000000003388210

DTC DETECTION LOGIC

DTC No.	Trouble diagnosis name	DTC detecting condition		Possible cause
P2119	Electric throttle control actuator	A)	Electric throttle control actuator does not function properly due to the return spring malfunction.	• Electric throttle control actuator
		B)	Throttle valve opening angle in fail-safe mode is not in specified range.	
		C)	ECM detects that the throttle valve is stuck open.	

DTC CONFIRMATION PROCEDURE

1. PRECONDITIONING

If DTC Confirmation Procedure has been previously conducted, always perform the following before conducting the next test.

1. Turn ignition switch OFF and wait at least 10 seconds.
2. Turn ignition switch ON.
3. Turn ignition switch OFF and wait at least 10 seconds.

>> GO TO 2.

2. PERFORM DTC CONFIRMATION PROCEDURE FOR MALFUNCTION A AND B

1. Turn ignition switch ON and wait at least 1 second.
2. Shift selector lever to the D position and wait at least 3 seconds.
3. Shift selector lever to the P position.
4. Turn ignition switch OFF and wait at least 10 seconds.
5. Turn ignition switch ON and wait at least 1 second.
6. Shift selector lever to the D position and wait at least 3 seconds.
7. Shift selector lever to the P position.
8. Turn ignition switch OFF, wait at least 10 seconds, and then turn ON.
9. Check DTC.

Is DTC detected?

YES >> Go to [EC-412, "Diagnosis Procedure"](#).

NO >> GO TO 3.

3. PERFORM DTC CONFIRMATION PROCEDURE FOR MALFUNCTION C

1. Turn ignition switch ON and wait at least 1 second.
2. Shift selector lever to the D position and wait at least 3 seconds.
3. Shift selector lever to the N or P position.
4. Start engine and let it idle for 3 seconds.
5. Check DTC.

Is DTC detected?

YES >> Go to [EC-412, "Diagnosis Procedure"](#).

NO >> INSPECTION END

P2119 ELECTRIC THROTTLE CONTROL ACTUATOR

< COMPONENT DIAGNOSIS >

[VQ35DE]

Diagnosis Procedure

INFOID:000000003630929

1. CHECK ELECTRIC THROTTLE CONTROL ACTUATOR VISUALLY

1. Turn ignition switch OFF.
2. Remove the intake air duct.
3. Check if foreign matter is caught between the throttle valve (1) and the housing.
 - Electric throttle control actuator (2)
 - ↵: Vehicle front

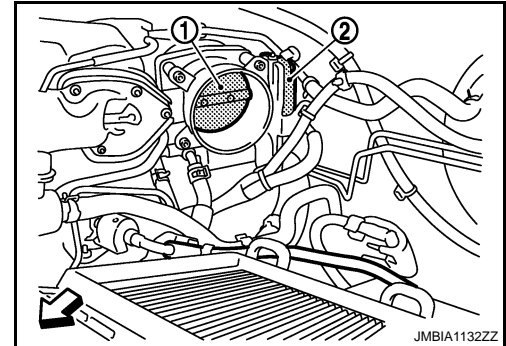

Is the inspection result normal?

- YES >> GO TO 2.
NO >> Remove the foreign matter and clean the electric throttle control actuator inside.

2. REPLACE ELECTRIC THROTTLE CONTROL ACTUATOR

1. Replace electric throttle control actuator.
2. Go to [EC-360, "Special Repair Requirement"](#).

>> INSPECTION END

Special Repair Requirement

INFOID:000000003388212

1. PERFORM THROTTLE VALVE CLOSED POSITION LEARNING

Refer to [EC-17, "THROTTLE VALVE CLOSED POSITION LEARNING : Special Repair Requirement"](#)

>> GO TO 2.

2. PERFORM IDLE AIR VOLUME LEARNING

Refer to [EC-17, "IDLE AIR VOLUME LEARNING : Special Repair Requirement"](#)

>> END

P2122, P2123 APP SENSOR

Description

INFOID:000000003388213

The accelerator pedal position sensor is installed on the upper end of the accelerator pedal assembly. The sensor detects the accelerator position and sends a signal to the ECM.

Accelerator pedal position sensor has two sensors. These sensors are a kind of potentiometer which transform the accelerator pedal position into output voltage, and emit the voltage signals to the ECM. The ECM judges the current opening angle of the accelerator pedal from these signals and controls the throttle control motor based on these signals.

Idle position of the accelerator pedal is determined by the ECM receiving the signal from the accelerator pedal position sensor. The ECM uses this signal for engine operations such as fuel cut.

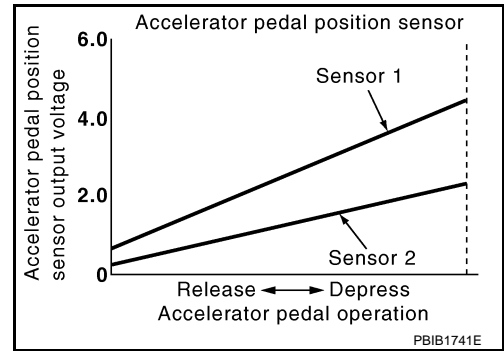

DTC Logic

INFOID:000000003388214

DTC DETECTION LOGIC

NOTE:

If DTC P2122 or P2123 is displayed with DTC P0643, first perform the trouble diagnosis for DTC P0643. Refer to [EC-347, "DTC Logic"](#).

DTC No.	Trouble diagnosis name	DTC detecting condition	Possible cause
P2122	Accelerator pedal position sensor 1 circuit low input	An excessively low voltage from the APP sensor 1 is sent to ECM.	<ul style="list-style-type: none"> • Harness or connectors (APP sensor 1 circuit is open or shorted.) • Accelerator pedal position sensor (APP sensor 1)
P2123	Accelerator pedal position sensor 1 circuit high input	An excessively high voltage from the APP sensor 1 is sent to ECM.	

DTC CONFIRMATION PROCEDURE

1. PRECONDITIONING

If DTC Confirmation Procedure has been previously conducted, always perform the following before conducting the next test.

1. Turn ignition switch OFF and wait at least 10 seconds.
2. Turn ignition switch ON.
3. Turn ignition switch OFF and wait at least 10 seconds.

TESTING CONDITION:

Before performing the following procedure, confirm that battery voltage is more than 10 V at idle.

>> GO TO 2.

2. PERFORM DTC CONFIRMATION PROCEDURE

1. Start engine and let it idle for 1 second.
2. Check DTC.

Is DTC detected?

- YES >> Go to [EC-413, "Diagnosis Procedure"](#).
- NO >> INSPECTION END

Diagnosis Procedure

INFOID:000000003388215

1. CHECK GROUND CONNECTION

1. Turn ignition switch OFF.
2. Check ground connection E38. Refer to Ground Inspection in [GI-43, "Circuit Inspection"](#).

Is the inspection result normal?

P2122, P2123 APP SENSOR

[VQ35DE]

< COMPONENT DIAGNOSIS >

- YES >> GO TO 2.
NO >> Repair or replace ground connection.

2.CHECK APP SENSOR 1 POWER SUPPLY CIRCUIT

1. Disconnect accelerator pedal position (APP) sensor harness connector.
2. Turn ignition switch ON.
3. Check the voltage between APP sensor harness connector and ground.

APP sensor		Ground	Voltage (V)
Connector	Terminal		
E110	4	Ground	Approx. 5

Is the inspection result normal?

- YES >> GO TO 3.
NO >> Repair open circuit, short to ground or short to power in harness or connectors.

3.CHECK APP SENSOR 1 GROUND CIRCUIT FOR OPEN AND SHORT

1. Turn ignition switch OFF.
2. Disconnect ECM harness connector.
3. Check the continuity between APP sensor harness connector and ECM harness connector.

APP sensor		ECM		Continuity
Connector	Terminal	Connector	Terminal	
E110	2	E16	84	Existed

4. Also check harness for short to ground and short to power.

Is the inspection result normal?

- YES >> GO TO 4.
NO >> Repair open circuit, short to ground or short to power in harness or connectors.

4.CHECK APP SENSOR INPUT SIGNAL CIRCUIT FOR OPEN AND SHORT

1. Check the continuity between APP sensor harness connector and ECM harness connector.

APP sensor		ECM		Continuity
Connector	Terminal	Connector	Terminal	
E110	3	E16	81	Existed

2. Also check harness for short to ground and short to power.

Is the inspection result normal?

- YES >> GO TO 5.
NO >> Repair open circuit, short to ground or short to power in harness or connectors.

5.CHECK APP SENSOR

Refer to [EC-415, "Component Inspection"](#).

Is the inspection result normal?

- YES >> GO TO 7.
NO >> GO TO 6.

6.REPLACE ACCELERATOR PEDAL ASSEMBLY

1. Replace accelerator pedal assembly.
2. Refer to [EC-415, "Special Repair Requirement"](#).

>> INSPECTION END

7.CHECK INTERMITTENT INCIDENT

Refer to [GI-40, "Intermittent Incident"](#).

P2122, P2123 APP SENSOR

< COMPONENT DIAGNOSIS >

[VQ35DE]

>> INSPECTION END

Component Inspection

INFOID:000000003388216

1. CHECK ACCELERATOR PEDAL POSITION SENSOR

1. Reconnect all harness connectors disconnected.
2. Turn ignition switch ON.
3. Check the voltage between ECM harness connector terminals under the following conditions.

ECM				Condition	Voltage (V)
+		-			
Connector	Terminal	Connector	Terminal		
E16	81 (APP sensor 1 signal)	E16	84 (Sensor ground)	Fully released	0.5 - 1.0
	82 (APP sensor 2 signal)		100 (Sensor ground)	Fully depressed	4.2 - 4.8
				Fully released	0.25 - 0.50
	Fully depressed		2.0 - 2.5		

Is the inspection result normal?

- YES >> INSPECTION END
NO >> GO TO 2.

2. REPLACE ACCELERATOR PEDAL ASSEMBLY

1. Replace accelerator pedal assembly.
2. Go to [EC-415. "Special Repair Requirement"](#).

>> INSPECTION END

Special Repair Requirement

INFOID:000000003388217

1. PERFORM ACCELERATOR PEDAL RELEASED POSITION LEARNING

Refer to [EC-17. "ACCELERATOR PEDAL RELEASED POSITION LEARNING : Special Repair Requirement"](#).

>> GO TO 2.

2. PERFORM THROTTLE VALVE CLOSED POSITION LEARNING

Refer to [EC-17. "THROTTLE VALVE CLOSED POSITION LEARNING : Special Repair Requirement"](#).

>> GO TO 3.

3. PERFORM IDLE AIR VOLUME LEARNING

Refer to [EC-17. "IDLE AIR VOLUME LEARNING : Special Repair Requirement"](#).

>> END

P2127, P2128 APP SENSOR

Description

INFOID:000000003591807

The accelerator pedal position sensor is installed on the upper end of the accelerator pedal assembly. The sensor detects the accelerator position and sends a signal to the ECM.

Accelerator pedal position sensor has two sensors. These sensors are a kind of potentiometer which transform the accelerator pedal position into output voltage, and emit the voltage signals to the ECM. The ECM judges the current opening angle of the accelerator pedal from these signals and controls the throttle control motor based on these signals.

Idle position of the accelerator pedal is determined by the ECM receiving the signal from the accelerator pedal position sensor. The ECM uses this signal for engine operations such as fuel cut.

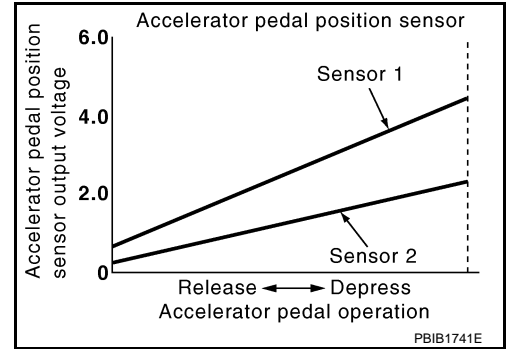

DTC Logic

INFOID:000000003388219

DTC DETECTION LOGIC

DTC No.	Trouble diagnosis name	DTC detecting condition	Possible cause
P2127	Accelerator pedal position sensor 2 circuit low input	An excessively low voltage from the APP sensor 2 is sent to ECM.	<ul style="list-style-type: none"> • Harness or connectors (APP sensor 2 circuit is open or shorted.) [CKP sensor (POS) circuit is shorted.] (Refrigerant pressure sensor circuit is shorted.) (EVAP control system pressure sensor circuit is shorted.) • Accelerator pedal position sensor (APP sensor 2) • Crankshaft position sensor (POS) • EVAP control system pressure sensor • Refrigerant pressure sensor
P2128	Accelerator pedal position sensor 2 circuit high input	An excessively high voltage from the APP sensor 2 is sent to ECM.	

DTC CONFIRMATION PROCEDURE

1. PRECONDITIONING

If DTC Confirmation Procedure has been previously conducted, always perform the following before conducting the next test.

1. Turn ignition switch OFF and wait at least 10 seconds.
2. Turn ignition switch ON.
3. Turn ignition switch OFF and wait at least 10 seconds.

TESTING CONDITION:

Before performing the following procedure, confirm that battery voltage is more than 8 V at idle.

>> GO TO 2.

2. PERFORM DTC CONFIRMATION PROCEDURE

1. Start engine and let it idle for 1 second.
2. Check DTC.

Is DTC detected?

- YES >> Go to [EC-416, "Diagnosis Procedure"](#).
- NO >> INSPECTION END

Diagnosis Procedure

INFOID:000000003388220

1. CHECK GROUND CONNECTION

1. Turn ignition switch OFF.
2. Check ground connection E38. Refer to Ground Inspection in [GI-43, "Circuit Inspection"](#).

P2127, P2128 APP SENSOR

[VQ35DE]

< COMPONENT DIAGNOSIS >

Is the inspection result normal?

- YES >> GO TO 2.
NO >> Repair or replace ground connection.

2.CHECK APP SENSOR 2 POWER SUPPLY CIRCUIT-I

1. Disconnect accelerator pedal position (APP) sensor harness connector.
2. Turn ignition switch ON.
3. Check the voltage between APP sensor harness connector and ground.

APP sensor		Ground	Voltage (V)
Connector	Terminal		
E110	5	Ground	Approx. 5

Is the inspection result normal?

- YES >> GO TO 6.
NO >> GO TO 3.

3.CHECK APP SENSOR 2 POWER SUPPLY CIRCUIT-II

1. Turn ignition switch OFF.
2. Disconnect ECM harness connector.
3. Check the continuity between APP sensor harness connector and ECM harness connector.

APP sensor		ECM		Continuity
Connector	Terminal	Connector	Terminal	
E110	5	E16	87	Existed

Is the inspection result normal?

- YES >> GO TO 4.
NO >> Repair open circuit.

4.CHECK SENSOR POWER SUPPLY CIRCUIT

Check harness for short to power and short to ground, between the following terminals.

ECM		Sensor		
Connector	Terminal	Name	Connector	Terminal
F8	72	Refrigerant pressure sensor	E300	1
	76	CKP sensor (POS)	F20	1
E16	87	APP sensor	E110	5
	91	EVAP control system pressure sensor	B17	3

Is the inspection result normal?

- YES >> GO TO 5.
NO >> Repair short to ground or short to power in harness or connectors.

5.CHECK COMPONENTS

Check the following.

- Crankshaft position sensor (POS) (Refer to [EC-263, "Component Inspection".](#))
- EVAP control system pressure sensor (Refer to [EC-302, "Component Inspection".](#))
- Refrigerant pressure sensor (Refer to [EC-463, "Diagnosis Procedure".](#))

Is the inspection result normal?

- YES >> GO TO 10.
NO >> Replace malfunctioning components.

6.CHECK APP SENSOR 2 GROUND CIRCUIT FOR OPEN AND SHORT

1. Turn ignition switch OFF.
2. Disconnect ECM harness connector.
3. Check the continuity between APP sensor harness connector and ECM harness connector.

P2127, P2128 APP SENSOR

[VQ35DE]

< COMPONENT DIAGNOSIS >

APP sensor		ECM		Continuity
Connector	Terminal	Connector	Terminal	
E110	1	E16	100	Existed

4. Also check harness for short to ground and short to power.

Is the inspection result normal?

YES >> GO TO 7.

NO >> Repair open circuit, short to ground or short to power in harness or connectors.

7. CHECK APP SENSOR 2 INPUT SIGNAL CIRCUIT FOR OPEN AND SHORT

1. Check the continuity between APP sensor harness connector and ECM harness connector.

APP sensor		ECM		Continuity
Connector	Terminal	Connector	Terminal	
E110	6	E16	82	Existed

2. Also check harness for short to ground and short to power.

Is the inspection result normal?

YES >> GO TO 8.

NO >> Repair open circuit, short to ground or short to power in harness or connectors.

8. CHECK APP SENSOR

Refer to [EC-418, "Component Inspection"](#).

Is the inspection result normal?

YES >> GO TO 10.

NO >> GO TO 9.

9. REPLACE ACCELERATOR PEDAL ASSEMBLY

1. Replace accelerator pedal assembly.
2. Refer to [EC-419, "Special Repair Requirement"](#)

>> INSPECTION END

10. CHECK INTERMITTENT INCIDENT

Refer to [GI-40, "Intermittent Incident"](#).

>> INSPECTION END

Component Inspection

INFOID:000000003591812

1. CHECK ACCELERATOR PEDAL POSITION SENSOR

1. Reconnect all harness connectors disconnected.
2. Turn ignition switch ON.
3. Check the voltage between ECM harness connector terminals under the following conditions.

ECM				Condition	Voltage (V)
+		-			
Connector	Terminal	Connector	Terminal		
E16	81 (APP sensor 1 signal)	E16	84 (Sensor ground)	Fully released	0.5 - 1.0
			100 (Sensor ground)	Fully depressed	4.2 - 4.8
	82 (APP sensor 2 signal)			Accelerator pedal	Fully released
			Fully depressed		2.0 - 2.5

P2127, P2128 APP SENSOR

[VQ35DE]

< COMPONENT DIAGNOSIS >

Is the inspection result normal?

YES >> INSPECTION END

NO >> GO TO 2.

2. REPLACE ACCELERATOR PEDAL ASSEMBLY

1. Replace accelerator pedal assembly.
2. Go to [EC-419, "Special Repair Requirement"](#).

>> INSPECTION END

Special Repair Requirement

INFOID:000000003591813

1. PERFORM ACCELERATOR PEDAL RELEASED POSITION LEARNING

Refer to [EC-17, "ACCELERATOR PEDAL RELEASED POSITION LEARNING : Special Repair Requirement"](#).

>> GO TO 2.

2. PERFORM THROTTLE VALVE CLOSED POSITION LEARNING

Refer to [EC-17, "THROTTLE VALVE CLOSED POSITION LEARNING : Special Repair Requirement"](#).

>> GO TO 3.

3. PERFORM IDLE AIR VOLUME LEARNING

Refer to [EC-17, "IDLE AIR VOLUME LEARNING : Special Repair Requirement"](#).

>> END

A

EC

C

D

E

F

G

H

I

J

K

L

M

N

O

P

P2135 TP SENSOR

< COMPONENT DIAGNOSIS >

[VQ35DE]

P2135 TP SENSOR

Description

INFOID:000000003388223

Electric throttle control actuator consists of throttle control motor, throttle position sensor, etc. The throttle position sensor responds to the throttle valve movement.

The throttle position sensor has two sensors. These sensors are a kind of potentiometers which transform the throttle valve position into output voltage, and emit the voltage signals to the ECM. In addition, these sensors detect the opening and closing speed of the throttle valve and feed the voltage signals to the ECM. The ECM judges the current opening angle of the throttle valve from these signals and the ECM controls the throttle control motor to make the throttle valve opening angle properly in response to driving condition.

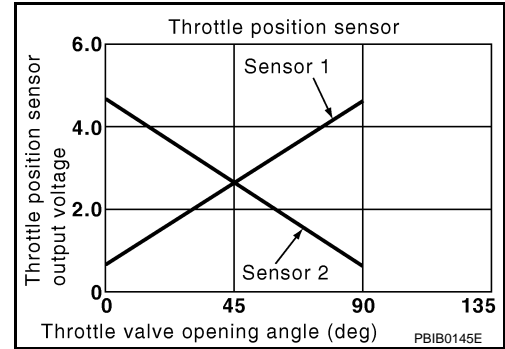

DTC Logic

INFOID:000000003388224

DTC DETECTION LOGIC

NOTE:

If DTC P2135 is displayed with DTC P0643, first perform the trouble diagnosis for DTC P0643. Refer to [EC-347, "DTC Logic"](#).

DTC No.	Trouble diagnosis name	DTC detecting condition	Possible cause
P2135	Throttle position sensor circuit range/performance	Rationally incorrect voltage is sent to ECM compared with the signals from TP sensor 1 and TP sensor 2.	<ul style="list-style-type: none">• Harness or connector (TP sensor 1 or 2 circuit is open or shorted.)• Electric throttle control actuator (TP sensor 1 or 2)

DTC CONFIRMATION PROCEDURE

1. PRECONDITIONING

If DTC Confirmation Procedure has been previously conducted, always perform the following before conducting the next test.

1. Turn ignition switch OFF and wait at least 10 seconds.
2. Turn ignition switch ON.
3. Turn ignition switch OFF and wait at least 10 seconds.

TESTING CONDITION:

Before performing the following procedure, confirm that battery voltage is more than 8 V at idle.

>> GO TO 2.

2. PERFORM DTC CONFIRMATION PROCEDURE

1. Start engine and let it idle for 1 second.
2. Check DTC.

Is DTC detected?

- YES >> Go to [EC-420, "Diagnosis Procedure"](#).
NO >> INSPECTION END

Diagnosis Procedure

INFOID:000000003388225

1. CHECK GROUND CONNECTION

1. Turn ignition switch OFF.
2. Check ground connection E38. Refer to Ground Inspection in [GI-43, "Circuit Inspection"](#).

Is the inspection result normal?

- YES >> GO TO 2.
NO >> Repair or replace ground connection.

P2135 TP SENSOR

< COMPONENT DIAGNOSIS >

[VQ35DE]

2. CHECK THROTTLE POSITION SENSOR POWER SUPPLY CIRCUIT-I

1. Disconnect electric throttle control actuator harness connector.
2. Turn ignition switch ON.
3. Check the voltage between electric throttle control actuator harness connector and ground.

Electric throttle control actuator		Ground	Voltage (V)
Connector	Terminal		
F29	1	Ground	Approx. 5

Is the inspection result normal?

YES >> GO TO 3.

NO >> Repair open circuit, short to ground or short to power in harness or connectors.

3. CHECK THROTTLE POSITION SENSOR GROUND CIRCUIT FOR OPEN AND SHORT

1. Turn ignition switch OFF.
2. Disconnect ECM harness connector.
3. Check the continuity between electric throttle control actuator harness connector and ECM harness connector.

Electric throttle control actuator		ECM		Continuity
Connector	Terminal	Connector	Terminal	
F29	4	F8	36	Existed

4. Also check harness for short to ground and short to power.

Is the inspection result normal?

YES >> GO TO 4.

NO >> Repair open circuit, short to ground or short to power in harness or connectors.

4. CHECK THROTTLE POSITION SENSOR INPUT SIGNAL CIRCUIT FOR OPEN AND SHORT

1. Check the continuity between electric throttle control actuator harness connector and ECM harness connector.

Electric throttle control actuator		ECM		Continuity
Connector	Terminal	Connector	Terminal	
F29	2	F8	37	Existed
	3		38	

2. Also check harness for short to ground and short to power.

Is the inspection result normal?

YES >> GO TO 5.

NO >> Repair open circuit, short to ground or short to power in harness or connectors.

5. CHECK THROTTLE POSITION SENSOR

Refer to [EC-422. "Component Inspection"](#).

Is the inspection result normal?

YES >> GO TO 7.

NO >> GO TO 6.

6. REPLACE ELECTRIC THROTTLE CONTROL ACTUATOR

1. Replace electric throttle control actuator.
2. Refer to [EC-422. "Special Repair Requirement"](#)

>> INSPECTION END

7. CHECK INTERMITTENT INCIDENT

Refer to [GI-40. "Intermittent Incident"](#).

P2135 TP SENSOR

< COMPONENT DIAGNOSIS >

[VQ35DE]

>> INSPECTION END

Component Inspection

INFOID:000000003388226

1. CHECK THROTTLE POSITION SENSOR

1. Turn ignition switch OFF.
2. Reconnect all harness connectors disconnected.
3. Perform [EC-422, "Special Repair Requirement"](#).
4. Turn ignition switch ON.
5. Shift selector lever position to D.
6. Check the voltage between ECM harness connector terminals under the following conditions.

ECM				Condition	Voltage
+		-			
Connector	Terminal	Connector	Terminal		
F8	37 (TP sensor 1 signal)	F8	36 (Sensor ground)	Fully released	More than 0.36 V
				Fully depressed	Less than 4.75 V
	38 (TP sensor 2 signal)			Fully released	Less than 4.75 V
				Fully depressed	More than 0.36 V

Is the inspection result normal?

YES >> INSPECTION END

NO >> GO TO 2.

2. REPLACE ELECTRIC THROTTLE CONTROL ACTUATOR

1. Replace electric throttle control actuator.
2. Go to [EC-422, "Special Repair Requirement"](#).

>> INSPECTION END

Special Repair Requirement

INFOID:000000003388227

1. PERFORM THROTTLE VALVE CLOSED POSITION LEARNING

Refer to [EC-17, "THROTTLE VALVE CLOSED POSITION LEARNING : Special Repair Requirement"](#)

>> GO TO 2.

2. PERFORM IDLE AIR VOLUME LEARNING

Refer to [EC-17, "IDLE AIR VOLUME LEARNING : Special Repair Requirement"](#)

>> END

P2138 APP SENSOR

Description

INFOID:000000003591874

The accelerator pedal position sensor is installed on the upper end of the accelerator pedal assembly. The sensor detects the accelerator position and sends a signal to the ECM.

Accelerator pedal position sensor has two sensors. These sensors are a kind of potentiometer which transform the accelerator pedal position into output voltage, and emit the voltage signals to the ECM. The ECM judges the current opening angle of the accelerator pedal from these signals and controls the throttle control motor based on these signals.

Idle position of the accelerator pedal is determined by the ECM receiving the signal from the accelerator pedal position sensor. The ECM uses this signal for engine operations such as fuel cut.

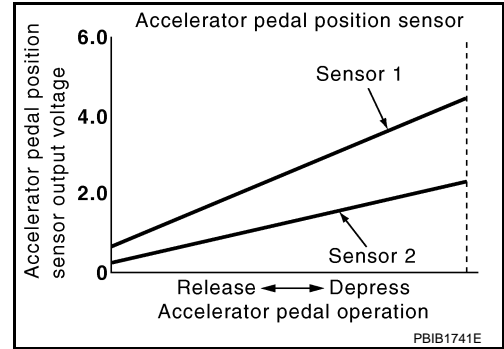

DTC Logic

INFOID:000000003388229

DTC DETECTION LOGIC

NOTE:

If DTC P2138 is displayed with DTC P0643, first perform the trouble diagnosis for DTC P0643. Refer to [EC-347, "DTC Logic"](#).

DTC No.	Trouble diagnosis name	DTC detecting condition	Possible cause
P2138	Accelerator pedal position sensor circuit range/performance	Rationally incorrect voltage is sent to ECM compared with the signals from APP sensor 1 and APP sensor 2.	<ul style="list-style-type: none"> • Harness or connector (APP sensor 1 or 2 circuit is open or shorted.) [CKP sensor (POS) circuit is shorted.] (Refrigerant pressure sensor circuit is shorted.) (EVAP control system pressure sensor circuit is shorted.) • Accelerator pedal position sensor (APP sensor 1 or 2) • Crankshaft position sensor (POS) • EVAP control system pressure sensor • Refrigerant pressure sensor

DTC CONFIRMATION PROCEDURE

1. PRECONDITIONING

If DTC Confirmation Procedure has been previously conducted, always perform the following before conducting the next test.

1. Turn ignition switch OFF and wait at least 10 seconds.
2. Turn ignition switch ON.
3. Turn ignition switch OFF and wait at least 10 seconds.

TESTING CONDITION:

Before performing the following procedure, confirm that battery voltage is more than 8 V at idle.

>> GO TO 2.

2. PERFORM DTC CONFIRMATION PROCEDURE

1. Start engine and let it idle for 1 second.
2. Check DTC.

Is DTC detected?

- YES >> Go to [EC-424, "Diagnosis Procedure"](#).
- NO >> INSPECTION END

P2138 APP SENSOR

[VQ35DE]

< COMPONENT DIAGNOSIS >

Diagnosis Procedure

INFOID:000000003388230

1. CHECK GROUND CONNECTION

1. Turn ignition switch OFF.
2. Check ground connection E38. Refer to Ground Inspection in [GI-43. "Circuit Inspection"](#).

Is the inspection result normal?

- YES >> GO TO 2.
NO >> Repair or replace ground connection.

2. CHECK APP SENSOR 1 POWER SUPPLY CIRCUIT

1. Disconnect accelerator pedal position (APP) sensor harness connector.
2. Turn ignition switch ON.
3. Check the voltage between APP sensor harness connector and ground.

APP sensor		Ground	Voltage (V)
Connector	Terminal		
E110	4	Ground	Approx. 5

Is the inspection result normal?

- YES >> GO TO 3.
NO >> Repair open circuit, short to ground or short to power in harness or connectors.

3. CHECK APP SENSOR 2 POWER SUPPLY CIRCUIT-I

1. Turn ignition switch ON.
2. Check the voltage between APP sensor harness connector and ground.

APP sensor		Ground	Voltage (V)
Connector	Terminal		
E110	5	Ground	Approx. 5

Is the inspection result normal?

- YES >> GO TO 7.
NO >> GO TO 4.

4. CHECK APP SENSOR 2 POWER SUPPLY CIRCUIT-II

1. Turn ignition switch OFF.
2. Disconnect ECM harness connector.
3. Check the continuity between APP sensor harness connector and ECM harness connector.

APP sensor		ECM		Continuity
Connector	Terminal	Connector	Terminal	
E110	5	E16	87	Existed

Is the inspection result normal?

- YES >> GO TO 5.
NO >> Repair open circuit.

5. CHECK SENSOR POWER SUPPLY CIRCUIT

Check harness for short to power and short to ground, between the following terminals.

ECM		Sensor		
Connector	Terminal	Name	Connector	Terminal
F8	72	Refrigerant pressure sensor	E300	1
	76	CKP sensor (POS)	F20	1

P2138 APP SENSOR

[VQ35DE]

< COMPONENT DIAGNOSIS >

ECM		Sensor		
Connector	Terminal	Name	Connector	Terminal
E16	87	APP sensor	E110	5
	91	EVAP control system pressure sensor	B17	3

Is the inspection result normal?

YES >> GO TO 6.

NO >> Repair short to ground or short to power in harness or connectors.

6. CHECK COMPONENTS

Check the following.

- Crankshaft position sensor (POS) (Refer to [EC-263, "Component Inspection"](#).)
- EVAP control system pressure sensor (Refer to [EC-302, "Component Inspection"](#).)
- Refrigerant pressure sensor (Refer to [EC-463, "Diagnosis Procedure"](#).)

Is the inspection result normal?

YES >> GO TO 11.

NO >> Replace malfunctioning components.

7. CHECK APP SENSOR GROUND CIRCUIT FOR OPEN AND SHORT

1. Turn ignition switch OFF.
2. Disconnect ECM harness connector.
3. Check the continuity between APP sensor harness connector and ECM harness connector.

APP sensor		ECM		Continuity
Connector	Terminal	Connector	Terminal	
E110	2	E16	84	Existed
	1		100	

4. Also check harness for short to ground and short to power.

Is the inspection result normal?

YES >> GO TO 8.

NO >> Repair open circuit, short to ground or short to power in harness or connectors.

8. CHECK APP SENSOR INPUT SIGNAL CIRCUIT FOR OPEN AND SHORT

1. Check the continuity between APP sensor harness connector and ECM harness connector.

APP sensor		ECM		Continuity
Connector	Terminal	Connector	Terminal	
E110	3	E16	81	Existed
	6		82	

2. Also check harness for short to ground and short to power.

Is the inspection result normal?

YES >> GO TO 9.

NO >> Repair open circuit, short to ground or short to power in harness or connectors.

9. CHECK APP SENSOR

Refer to [EC-426, "Component Inspection"](#).

Is the inspection result normal?

YES >> GO TO 11.

NO >> GO TO 10.

10. REPLACE ACCELERATOR PEDAL ASSEMBLY

1. Replace accelerator pedal assembly.
2. Refer to [EC-426, "Special Repair Requirement"](#).

P2138 APP SENSOR

[VQ35DE]

< COMPONENT DIAGNOSIS >

>> INSPECTION END

11. CHECK INTERMITTENT INCIDENT

Refer to [GI-40, "Intermittent Incident"](#).

>> INSPECTION END

Component Inspection

INFOID:000000003591875

1. CHECK ACCELERATOR PEDAL POSITION SENSOR

1. Reconnect all harness connectors disconnected.
2. Turn ignition switch ON.
3. Check the voltage between ECM harness connector terminals under the following conditions.

ECM				Condition	Voltage (V)
+		-			
Connector	Terminal	Connector	Terminal		
E16	81 (APP sensor 1 signal)	E16	84 (Sensor ground)	Fully released	0.5 - 1.0
	82 (APP sensor 2 signal)		100 (Sensor ground)	Fully depressed	4.2 - 4.8
				Fully released	0.25 - 0.50
				Fully depressed	2.0 - 2.5

Is the inspection result normal?

- YES >> INSPECTION END
NO >> GO TO 2.

2. REPLACE ACCELERATOR PEDAL ASSEMBLY

1. Replace accelerator pedal assembly.
2. Go to [EC-426, "Special Repair Requirement"](#).

>> INSPECTION END

Special Repair Requirement

INFOID:000000003591879

1. PERFORM ACCELERATOR PEDAL RELEASED POSITION LEARNING

Refer to [EC-17, "ACCELERATOR PEDAL RELEASED POSITION LEARNING : Special Repair Requirement"](#).

>> GO TO 2.

2. PERFORM THROTTLE VALVE CLOSED POSITION LEARNING

Refer to [EC-17, "THROTTLE VALVE CLOSED POSITION LEARNING : Special Repair Requirement"](#).

>> GO TO 3.

3. PERFORM IDLE AIR VOLUME LEARNING

Refer to [EC-17, "IDLE AIR VOLUME LEARNING : Special Repair Requirement"](#).

>> END

P2A00, P2A03 A/F SENSOR 1

Description

INFOID:000000003591593

The air fuel ratio (A/F) sensor 1 is a planar one-cell limit current sensor. The sensor element of the A/F sensor 1 is composed an electrode layer, which transports ions. It has a heater in the element. The sensor is capable of precise measurement $\lambda = 1$, but also in the lean and rich range. Together with its control electronics, the sensor outputs a clear, continuous signal throughout a wide λ range. The exhaust gas components diffuse through the diffusion layer at the sensor cell. An electrode layer is applied voltage, and this current relative oxygen density in lean. Also this current relative hydrocarbon density in rich.

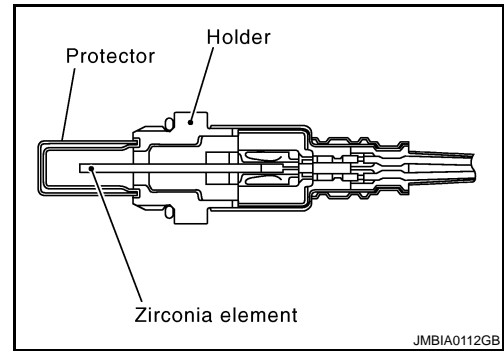

Therefore, the A/F sensor 1 is able to indicate air fuel ratio by this electrode layer of current. In addition, a heater is integrated in the sensor to ensure the required operating temperature of approximately 800°C (1,472°F).

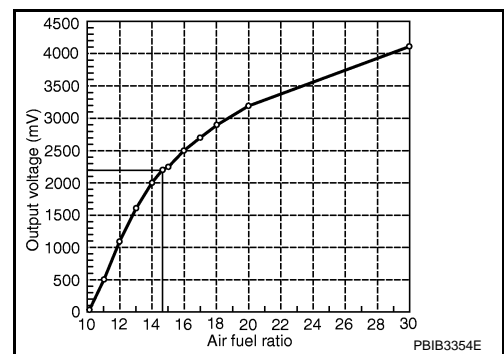

DTC Logic

INFOID:000000003388234

DTC DETECTION LOGIC

To judge the malfunction, the A/F signal computed by ECM from the A/F sensor 1 signal is monitored so it will not shift to LEAN side or RICH side.

DTC No.	Trouble diagnosis name	DTC detecting condition	Possible Cause
P2A00	Air fuel ratio (A/F) sensor 1 (bank 1) circuit range/performance	<ul style="list-style-type: none"> The output voltage computed by ECM from the A/F sensor 1 signal shifts to the lean side for a specified period. 	<ul style="list-style-type: none"> A/F sensor 1 A/F sensor 1 heater Fuel pressure Fuel injector Intake air leakage
P2A03	Air fuel ratio (A/F) sensor 1 (bank 2) circuit range/performance	<ul style="list-style-type: none"> The A/F signal computed by ECM from the A/F sensor 1 signal is shifts to the rich side for a specified period. 	

DTC CONFIRMATION PROCEDURE

1. PRECONDITIONING

If DTC Confirmation Procedure has been previously conducted, always perform the following before conducting the next test.

1. Turn ignition switch OFF and wait at least 10 seconds.
2. Turn ignition switch ON.
3. Turn ignition switch OFF and wait at least 10 seconds.

TESTING CONDITION:

Before performing the following procedure, confirm that battery voltage is more than 11 V at idle.

>> GO TO 2.

2. PERFORM DTC CONFIRMATION PROCEDURE

1. Clear the mixture ratio self-learning value. Refer to [EC-19. "MIXTURE RATIO SELF-LEARNING VALUE CLEAR : Special Repair Requirement"](#).
2. Turn ignition switch OFF and wait at least 10 seconds.

< COMPONENT DIAGNOSIS >

3. Turn ignition switch ON.
4. Turn ignition switch OFF and wait at least 10 seconds.
5. Start engine and keep the engine speed between 3,500 and 4,000 rpm for 1 minute under no load.
6. Let engine idle for 1 minute.
7. Keep engine speed between 2,500 and 3,000 rpm for 20 minutes.
8. Check 1st trip DTC.

Is 1st trip DTC detected?

- YES >> Go to [EC-428, "Diagnosis Procedure"](#).
NO >> INSPECTION END

Diagnosis Procedure

INFOID:000000003388235

1. CHECK GROUND CONNECTION

1. Turn ignition switch OFF.
2. Check ground connection E38. Refer to Ground Inspection in [GI-43, "Circuit Inspection"](#).

Is the inspection result normal?

- YES >> GO TO 2.
NO >> Repair or replace ground connection.

2. RETIGHTEN A/F SENSOR 1

Loosen and retighten the A/F sensor 1. Refer to [EM-34, "Removal and Installation"](#).

>> GO TO 3.

3. CHECK FOR INTAKE AIR LEAKAGE

1. Start engine and run it at idle.
2. Listen for an intake air leakage after the mass air flow sensor.

Is intake air leakage detected?

- YES >> GO TO 4.
NO >> Repair or replace malfunctioning part.

4. CLEAR THE MIXTURE RATIO SELF-LEARNING VALUE

1. Clear the mixture ratio self-learning value. Refer to [EC-19, "MIXTURE RATIO SELF-LEARNING VALUE CLEAR : Special Repair Requirement"](#).
2. Run engine for at least 10 minutes at idle speed.

Is the 1st trip DTC P0171, P0172, P0174 or P0175 detected? Is it difficult to start engine?

- YES >> Perform trouble diagnosis for DTC P0171, P0174 or P0172, P0175. Refer to [EC-226, "DTC Logic"](#) or [EC-231, "DTC Logic"](#).
NO >> GO TO 5.

5. CHECK HARNESS CONNECTOR

1. Turn ignition switch OFF.
2. Disconnect A/F sensor 1 harness connector.
3. Check harness connector for water.

Water should not exit.

Is the inspection result normal?

- YES >> GO TO 6.
NO >> Repair or replace harness connector.

6. CHECK AIR FUEL RATIO (A/F) SENSOR 1 POWER SUPPLY CIRCUIT

1. Disconnect A/F sensor 1 harness connector.
2. Turn ignition switch ON.
3. Check the voltage between A/F sensor 1 harness connector and ground.

P2A00, P2A03 A/F SENSOR 1

< COMPONENT DIAGNOSIS >

[VQ35DE]

DTC	A/F sensor			Ground	Voltage (V)
	Bank	Connector	Terminal		
P2A00	1	F27	4	Ground	Battery voltage
P2A03	2	F64	4		

Is the inspection result normal?

- YES >> GO TO 8.
- NO >> GO TO 7.

7. DETECT MALFUNCTIONING PART

Check the following.

- IPDM E/R harness connector F12
- 15 A fuse (No. 46)
- Harness for open or short between A/F sensor 1 and IPDM E/R

>> Repair or replace harness or connectors.

8. CHECK A/F SENSOR 1 INPUT SIGNAL CIRCUIT FOR OPEN AND SHORT

1. Turn ignition switch OFF.
2. Disconnect ECM harness connector.
3. Check the continuity between A/F sensor 1 harness connector and ECM harness connector.

DTC	A/F sensor 1			ECM		Continuity
	Bank	Connector	Terminal	Connector	Terminal	
P2A00	1	F27	1	F8	45	Existed
			2		49	
P2A03	2	F64	1		53	
			2		57	

4. Check the continuity between A/F sensor 1 harness connector and ground, or ECM harness connector and ground.

DTC	A/F sensor 1			Ground	Continuity
	Bank	Connector	Terminal		
P2A00	1	F27	1	Ground	Not existed
			2		
P2A03	2	F64	1		
			2		

DTC	ECM		Ground	Continuity
	Connector	Terminal		
P2A00	F8	45	Ground	Not existed
		49		
P2A03		53		
		57		

5. Also check harness for short to power.

Is the inspection result normal?

- YES >> GO TO 9.
- NO >> Repair open circuit, short to ground or short to power in harness or connectors.

9. CHECK INTERMITTENT INCIDENT

P2A00, P2A03 A/F SENSOR 1

[VQ35DE]

< COMPONENT DIAGNOSIS >

Perform [GI-40. "Intermittent Incident"](#).

Is the inspection result normal?

YES >> GO TO 10.

NO >> Repair or replace malfunctioning part.

10.REPLACE AIR FUEL RATIO (A/F) SENSOR 1

Replace malfunctioning air fuel ratio (A/F) sensor 1.

CAUTION:

- Discard any A/F sensor which has been dropped from a height of more than 0.5 m (19.7 in) onto a hard surface such as a concrete floor; use a new one.
- Before installing new A/F sensor, clean exhaust system threads using Oxygen Sensor Thread Cleaner [commercial service tool (J-43897-18 or J-43897-12)] and approved anti-seize lubricant (commercial service tool).

>> INSPECTION END

ASCD BRAKE SWITCH

< COMPONENT DIAGNOSIS >

[VQ35DE]

ASCD BRAKE SWITCH

Description

INFOID:000000003591756

When the brake pedal is depressed, ASCD brake switch is turned OFF and stop lamp switch is turned ON. ECM detects the state of the brake pedal by those two types of input (ON/OFF signal). Refer to [EC-51, "System Diagram"](#) for the ASCD function.

Component Function Check

INFOID:000000003388237

1. CHECK ASCD BRAKE SWITCH FUNCTION

With CONSULT-III

1. Turn ignition switch ON.
2. Select "BRAKE SW1" in "DATA MONITOR" mode with CONSULT-III.
3. Check "BRAKE SW1" indication under the following conditions.

Monitor item	Condition		Indication
BRAKE SW1	Brake pedal	Slightly depressed	OFF
		Fully released	ON

Without CONSULT-III

1. Turn ignition switch ON.
2. Check the voltage between ECM harness connector terminals.

Connector	ECM		Condition	Voltage	
	+	-			
	Terminal	Terminal			
E16	110 (ASCD brake switch signal)	112	Brake pedal	Slightly depressed	Approx. 0 V
			Fully released	Battery voltage	

Is the inspection result normal?

- YES >> INSPECTION END
NO >> Go to [EC-431, "Diagnosis Procedure"](#).

Diagnosis Procedure

INFOID:000000003388238

1. CHECK ASCD BRAKE SWITCH POWER SUPPLY CIRCUIT

1. Turn ignition switch OFF.
2. Disconnect ASCD brake switch harness connector.
3. Turn ignition switch ON.
4. Check the voltage between ASCD brake switch harness connector and ground.

ASCD brake switch		Ground	Voltage
Connector	Terminal		
E49	1	Ground	Battery voltage

Is the inspection result normal?

- YES >> GO TO 3.
NO >> GO TO 2.

2. DETECT MALFUNCTIONING PART

Check the following.

- Fuse block (J/B) connector E103
- 10 A fuse (No.3)
- Harness for open or short between ASCD brake switch and fuse

ASCD BRAKE SWITCH

[VQ35DE]

< COMPONENT DIAGNOSIS >

>> Repair open circuit, short to ground or short to power in harness or connectors.

3. CHECK ASCD BRAKE SWITCH INPUT SIGNAL CIRCUIT FOR OPEN AND SHORT

1. Turn ignition switch OFF.
2. Disconnect ECM harness connector.
3. Check the continuity between ASCD brake switch harness connector and ECM harness connector.

ASCD brake switch		ECM		Continuity
Connector	Terminal	Connector	Terminal	
E49	2	E16	110	Existed

4. Also check harness for short to ground and short to power.

Is the inspection result normal?

YES >> GO TO 4.

NO >> Repair open circuit, short to ground or short to power in harness or connectors.

4. CHECK ASCD BRAKE SWITCH

Refer to [EC-432. "Component Inspection \(ASCD Brake Switch\)".](#)

Is the inspection result normal?

YES >> GO TO 5.

NO >> Replace ASCD brake switch.

5. CHECK INTERMITTENT INCIDENT

Refer to [GI-40. "Intermittent Incident".](#)

>> INSPECTION END

Component Inspection (ASCD Brake Switch)

INFOID:000000003591752

1. CHECK ASCD BRAKE SWITCH-I

1. Turn ignition switch OFF.
2. Disconnect ASCD brake switch harness connector.
3. Check the continuity between ASCD brake switch terminals under the following conditions.

Terminals	Condition		Continuity
1 and 2	Brake pedal	Fully released	Existed
		Slightly depressed	Not existed

Is the inspection result normal?

YES >> INSPECTION END

NO >> GO TO 2.

2. CHECK ASCD BRAKE SWITCH-II

1. Adjust ASCD brake switch installation. Refer to [BR-9. "Inspection and Adjustment".](#)
2. Check the continuity between ASCD brake switch terminals under the following conditions.

Terminals	Condition		Continuity
1 and 2	Brake pedal	Fully released	Existed
		Slightly depressed	Not existed

Is the inspection result normal?

YES >> INSPECTION END

NO >> Replace ASCD brake switch.

ASC D INDICATOR

Description

INFOID:000000003388241

ASC D indicator lamp illuminates to indicate ASC D operation status. CRUISE is integrated in combination meter.

CRUISE illuminates when MAIN switch on ASC D steering switch is turned ON to indicate that ASC D system is ready for operation.

Refer to [EC-51. "System Diagram"](#) for the ASC D function.

Component Function Check

INFOID:000000003388242

1. CHECK ASC D INDICATOR FUNCTION

Check ASC D indicator under the following conditions.

ASC D INDICATOR	CONDITION		SPECIFICATION
CRUISE	<ul style="list-style-type: none"> • Ignition switch: ON 	<ul style="list-style-type: none"> • MAIN switch: Pressed at the 1st time → at the 2nd time 	ON → OFF

Is the inspection result normal?

YES >> INSPECTION END

NO >> Go to [EC-433. "Diagnosis Procedure"](#).

Diagnosis Procedure

INFOID:000000003388243

1. CHECK DTC

Check that DTC UXXXX is not displayed.

Is the inspection result normal?

YES >> GO TO 2.

NO >> Perform trouble diagnosis for DTC UXXXX.

2. CHECK COMBINATION METER FUNCTION

Refer to [MWI-34. "CONSULT-III Function \(METER/M&A\)"](#).

Is the inspection result normal?

YES >> GO TO 3.

NO >> Repair or replace malfunctioning part.

3. CHECK INTERMITTENT INCIDENT

Refer to [GI-40. "Intermittent Incident"](#).

Is the inspection result normal?

YES >> Replace combination meter.

NO >> Repair or replace malfunctioning part.

A
EC
C
D
E
F
G
H
I
J
K
L
M
N
O
P

COOLING FAN

< COMPONENT DIAGNOSIS >

[VQ35DE]

COOLING FAN

Description

INFOID:000000003388244

The ECM controls the cooling fan corresponding to the vehicle speed, engine coolant temperature, refrigerant pressure, and air conditioner ON signal. The control system has 4-step control [HIGH/MIDDLE/LOW/OFF].

COOLING FAN MOTOR

The cooling fan operates at each speed when the current flows in the cooling fan motor as per the following.

Cooling fan speed	Cooling fan motor terminals	
	(+)	(-)
Middle (MID)	1	3 and 4
	2	3 and 4
	1 and 2	3
	1 and 2	4
High (HI)	1 and 2	3 and 4

The cooling fan operates at low (LOW) speed when cooling fan motors-1 and -2 are circuited in series under the middle speed condition.

Refer to [EC-60, "System Diagram"](#).

Component Function Check

INFOID:000000003388245

1. CHECK COOLING FAN FUNCTION

With CONSULT-III

1. Turn ignition switch ON.
2. Perform "COOLING FAN" in "ACTIVE TEST" mode with CONSULT-III.
3. Check that cooling fan operates at each speed.

Without CONSULT-III

1. Perform IPDM E/R auto active test and check cooling fan motors operation, refer to [PCS-10, "Diagnosis Description"](#).
2. Check that cooling fan operates at each speed.

Is the inspection result normal?

YES >> INSPECTION END

NO >> Go to [EC-434, "Diagnosis Procedure"](#).

Diagnosis Procedure

INFOID:000000003388246

1. CHECK COOLING FAN RELAY POWER SUPPLY CIRCUIT

1. Turn ignition switch OFF.
2. Disconnect cooling fan relays-2, -3.
3. Turn ignition switch ON.
4. Check the voltage between cooling fan relays-2, -3 harness connectors and ground.

Cooling fan relay		Ground	Voltage
Connector	Terminal		
E57 (cooling fan relay-2)	2	Ground	Battery voltage
	5		
E59 (cooling fan relay-3)	2		
	5		

Is the inspection result normal?

YES >> GO TO 3.

NO >> GO TO 2.

COOLING FAN

< COMPONENT DIAGNOSIS >

[VQ35DE]

2. DETECT MALFUNCTIONING PART

Check the following.

- 40 A fusible link (letter K)
- 10 A fuse (No. 42)
- IPDM E/R harness connector E10
- Harness for open or short between cooling fan relay-2 and battery
- Harness for open or short between cooling fan relay-3 and battery
- Harness for open or short between cooling fan relay-2 and IPDM E/R
- Harness for open or short between cooling fan relay-3 and IPDM E/R

>> Repair open circuit, short to ground or short to power in harness or connectors.

3. CHECK COOLING FAN RELAY OUTPUT SIGNAL CIRCUIT

1. Turn ignition switch OFF.
2. Disconnect IPDM E/R harness connectors.
3. Check the continuity between cooling fan relay-2, -3 harness connectors and IPDM E/R harness connector.

Cooling fan relay		IPDM E/R		Continuity
Connector	Terminal	Connector	Terminal	
E57 (cooling fan relay-2)	1	E11	42	Existed
E59 (cooling fan relay-3)	1	E10	34	

4. Also check harness for short to ground and short to power.

Is the inspection result normal?

YES >> GO TO 4.

NO >> Repair open circuit, short to ground or short to power in harness or connectors.

4. CHECK COOLING FAN MOTOR POWER SUPPLY CIRCUIT

1. Disconnect cooling fan motor-1 harness connector.
2. Check the voltage between cooling fan motor-1 harness connector and ground.

Cooling fan motor-1		Ground	Voltage
Connector	Terminal		
E301	1	Ground	Battery voltage
	2		

Is the inspection result normal?

YES >> GO TO 6.

NO >> GO TO 5.

5. DETECT MALFUNCTIONING PART

Check the following.

- Harness connector E70, E305
- 40 A fusible link (letter M)
- Harness for open or short between cooling fan motor-1 and battery

>> Repair open circuit, short to ground or short to power in harness or connectors.

6. CHECK COOLING FAN MOTOR CIRCUIT-I

1. Disconnect cooling fan motor-2 harness connector.
2. Check the continuity between cooling fan relay-2, -3 harness connectors and cooling fan motor-1, -2 harness connectors.

COOLING FAN

< COMPONENT DIAGNOSIS >

[VQ35DE]

Cooling fan relay		Cooling fan motor		Continuity
Connector	Terminal	Connector	Terminal	
E57 (cooling fan relay-2)	3	E302 (Cooling fan motor-2)	2	Existed
	7	E301 (Cooling fan motor-1)	3	
E59 (cooling fan relay-3)	3	E302 (Cooling fan motor-2)	1	
	7	E301 (Cooling fan motor-1)	4	

3. Also check harness for short to ground and short to power.

Is the inspection result normal?

YES >> GO TO 8.

NO >> GO TO 7.

7. DETECT MALFUNCTIONING PART

Check the following.

- Harness connector E70, E305
- Harness for open or short between cooling fan motor-1 and cooling fan relay-2
- Harness for open or short between cooling fan motor-1 and cooling fan relay-3
- Harness for open or short between cooling fan motor-2 and cooling fan relay-2
- Harness for open or short between cooling fan motor-2 and cooling fan relay-3

>> Repair open circuit, short to ground or short to power in harness or connectors.

8. CHECK COOLING FAN MOTOR CIRCUIT-II

1. Check the continuity between IPDM E/R harness connector and cooling fan motor-1, -2 harness connector.

IPDM E/R		Cooling fan motor		Continuity
Connector	Terminal	Connector	Terminal	
E10	35	E301 (Cooling fan motor-1)	4	Existed
	38	E302 (Cooling fan motor-2)	1	

2. Also check harness for short to ground and short to power.

Is the inspection result normal?

YES >> GO TO 10.

NO >> GO TO 9.

9. DETECT MALFUNCTIONING PART

Check the following.

- Harness connector E70, E305
- Harness for open or short between cooling fan motor-1 and IPDM E/R
- Harness for open or short between cooling fan motor-2 and IPDM E/R

>> Repair open circuit, short to ground or short to power in harness or connectors.

10. CHECK COOLING FAN MOTOR CIRCUIT-III

1. Check the continuity between cooling fan relay-2, -3 harness connectors and ground.

COOLING FAN

< COMPONENT DIAGNOSIS >

[VQ35DE]

Cooling fan motor		Ground	Continuity
Connector	Terminal		
E57 (cooling fan relay-2)	6	Ground	Existed
E59 (cooling fan relay-3)	6		

2. Also check harness for short to ground and short to power.

Is the inspection result normal?

YES >> GO TO 11.

NO >> Repair open circuit, short to ground or short to power in harness or connectors.

11.CHECK COOLING FAN MOTOR CIRCUIT-IV

1. Check the continuity between cooling fan motor-2 harness connector and ground.

Cooling fan motor-2		Ground	Continuity
Connector	Terminal		
E302	3	Ground	Existed
	4		

2. Also check harness for short to ground and short to power.

Is the inspection result normal?

YES >> GO TO 12.

NO >> Repair open circuit, short to ground or short to power in harness or connectors.

12.CHECK COOLING FAN RELAYS-2 AND -3

Refer to [EC-438. "Component Inspection \(Cooling Fan Relay\)".](#)

Is the inspection result normal?

YES >> GO TO 13.

NO >> Replace malfunctioning cooling fan relay.

13.CHECK COOLING FAN MOTORS-1 AND -2

Refer to [EC-437. "Component Inspection \(Cooling Fan Motor\)".](#)

Is the inspection result normal?

YES >> GO TO 14.

NO >> Replace malfunctioning cooling fan motor.

14.CHECK INTERMITTENT INCIDENT

Perform [GI-40. "Intermittent Incident".](#)

Is the inspection result normal?

YES >> Replace IPDM E/R.

NO >> Repair or replace harness connectors.

Component Inspection (Cooling Fan Motor)

INFOID:000000003388247

1.CHECK COOLING FAN MOTOR

1. Turn ignition switch OFF.
2. Disconnect cooling fan motor harness connector.
3. Supply cooling fan motor terminals with battery voltage and check operation.

COOLING FAN

< COMPONENT DIAGNOSIS >

[VQ35DE]

	Condition	Terminals	
		(+)	(-)
Cooling fan motor	A	1	3 and 4
		2	3 and 4
		1 and 2	3
		1 and 2	4
	B	1, 2	3, 4

Check that cooling fan speed of condition B is higher than that of A.

Is the inspection result normal?

- YES >> INSPECTION END
- NO >> Replace cooling fan motor.

Component Inspection (Cooling Fan Relay)

INFOID:000000003388248

1. CHECK COOLING FAN RELAY

1. Disconnect cooling fan relays -2, -3 harness connectors.
2. Check continuity between cooling fan relay -2, -3 terminals under the following conditions.

Terminals	Conditions	Continuity
3 and 5 6 and 7	12 V direct current supply between terminals 1 and 2	Existed
	No current supply	Not existed

Is the inspection result normal?

- YES >> INSPECTION END
- NO >> Replace cooling fan relay.

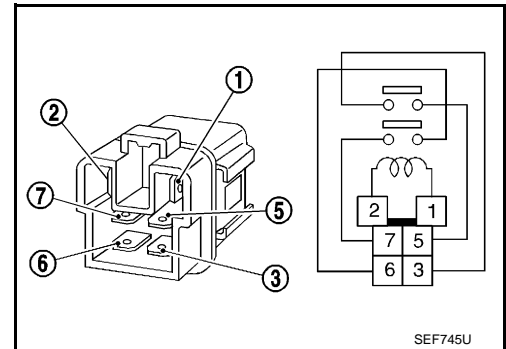

SEF745U

ELECTRICAL LOAD SIGNAL

< COMPONENT DIAGNOSIS >

[VQ35DE]

ELECTRICAL LOAD SIGNAL

Description

INFOID:000000003388249

The electrical load signal (Headlamp switch signal, rear window defogger switch signal, etc.) is transferred via the CAN communication.

Component Function Check

INFOID:000000003388250

1. CHECK REAR WINDOW DEFOGGER SWITCH FUNCTION

1. Turn ignition switch ON.
2. Connect CONSULT-III and select "DATA MONITOR" mode.
3. Select "LOAD SIGNAL" and check indication under the following conditions.

Monitor item	Condition	Indication	
LOAD SIGNAL	Rear window defogger switch	ON	ON
		OFF	OFF

Is the inspection result normal?

YES >> GO TO 2.

NO >> Go to [EC-439, "Diagnosis Procedure"](#).

2. CHECK LIGHTING SWITCH FUNCTION

Check "LOAD SIGNAL" indication under the following conditions.

Monitor item	Condition	Indication	
LOAD SIGNAL	Lighting switch	ON at 2nd position	ON
		OFF	OFF

Is the inspection result normal?

YES >> GO TO 3.

NO >> Go to [EC-439, "Diagnosis Procedure"](#).

3. CHECK HEATER FAN CONTROL SWITCH FUNCTION

Select "HEATER FAN SW" and check indication under the following conditions.

Monitor item	Condition	Indication	
HEATER FAN SW	Heater fan control switch	ON	ON
		OFF	OFF

Is the inspection result normal?

YES >> INSPECTION END

NO >> Go to [EC-439, "Diagnosis Procedure"](#).

Diagnosis Procedure

INFOID:000000003388251

1. INSPECTION START

Confirm the malfunctioning circuit (rear window defogger, headlamp or heater fan). Refer to [EC-439, "Component Function Check"](#).

Which circuit is related to the incident?

Rear window defogger >> GO TO 2.

Headlamp >> GO TO 3.

Heater fan >> GO TO 4.

2. CHECK REAR WINDOW DEFOGGER SYSTEM

Refer to [DEF-3, "Work Flow"](#).

ELECTRICAL LOAD SIGNAL

[VQ35DE]

< COMPONENT DIAGNOSIS >

>> INSPECTION END

3.CHECK HEADLAMP SYSTEM

Refer to [EXL-6, "Work Flow"](#) (XENON TYPE) or [EXL-189, "Work Flow"](#) (HALOGEN TYPE).

>> INSPECTION END

4.CHECK HEATER FAN CONTROL SYSTEM

Refer to [VTL-5, "System Description"](#).

>> INSPECTION END

ELECTRONIC CONTROLLED ENGINE MOUNT

< COMPONENT DIAGNOSIS >

[VQ35DE]

ELECTRONIC CONTROLLED ENGINE MOUNT

Description

INFOID:000000003388252

The electronic controlled engine mount control solenoid valve controls the intake manifold vacuum signal for electronic controlled engine mount. The electronic controlled engine mount control solenoid valve is moved by ON/OFF signal from the ECM. When the solenoid is OFF, the vacuum signal from the intake manifold is cut. When the solenoid is ON, the intake manifold vacuum signal is sent to the electronic controlled engine mount.

Component Function Check

INFOID:000000003388253

1.CHECK OVERALL FUNCTION

1. Start engine and warm it up to normal operating temperature.
2. Shift selector position is D while depressing the brake pedal and parking brake pedal.
3. Disconnect electronic controlled engine mount control solenoid valve harness connector.
4. Check that body vibration increases compared to the condition of step 2 above (with vehicle stopped).

Is the inspection result normal?

- YES >> INSPECTION END
NO >> [EC-441, "Diagnosis Procedure"](#).

Diagnosis Procedure

INFOID:000000003388254

1.CHECK VACUUM SOURCE

1. Turn ignition switch OFF.
2. Reconnect electronic controlled engine mount control solenoid valve harness connector.
3. Disconnect vacuum hose connected to electronic controlled engine mount.
4. Start engine and let it idle.
5. Check vacuum hose for vacuum existence.

Vacuum should exist.

Is the inspection result normal?

- YES >> GO TO 7.
NO >> GO TO 2.

2.CHECK VACUUM HOSES AND VACUUM GALLERY

1. Turn ignition switch OFF.
2. Check vacuum hoses and vacuum gallery for clogging, cracks or improper connection. Refer to [EC-68, "System Diagram"](#).

Is the inspection result normal?

- YES >> GO TO 3.
NO >> Repair or replace vacuum hoses and vacuum gallery.

3.CHECK ELECTRONIC CONTROLLED ENGINE MOUNT CONTROL SOLENOID VALVE POWER SUPPLY CIRCUIT

1. Disconnect electronic controlled engine mount control solenoid valve harness connector.
2. Turn ignition switch ON.
3. Check the voltage between front electronic controlled engine mount harness connector and ground.

Electronic controlled engine mount control solenoid valve		Ground	Voltage
Connector	Terminal		
F11	1	Ground	Battery voltage

Is the inspection result normal?

- YES >> GO TO 5.
NO >> GO TO 4.

4.DETECT MALFUNCTIONING PART

ELECTRONIC CONTROLLED ENGINE MOUNT

[VQ35DE]

< COMPONENT DIAGNOSIS >

Check the following.

- Harness connectors E6, F123
- 10 A fuse (No. 3)
- Fuse block (J/B) connector E103
- Harness for open or short between electronic controlled engine mount control solenoid valve and fuse

>> Repair open circuit, short to ground or short to power in harness or connectors.

5. CHECK ELECTRONIC CONTROLLED ENGINE MOUNT CONTROL SOLENOID VALVE OUTPUT SIGNAL CIRCUIT FOR OPEN AND SHORT

1. Disconnect ECM harness connector.
2. Check the continuity between ECM harness connector and electronic controlled engine mount control solenoid valve harness connector.

ECM		Electronic controlled engine mount control solenoid valve		Continuity
Connector	Terminal	Connector	Terminal	
F7	28	F11	2	Existed

3. Also check harness for short to ground and short to power.

Is the inspection result normal?

YES >> GO TO 6.

NO >> Repair open circuit, short to ground or short to power in harness connectors.

6. CHECK ELECTRONIC CONTROLLED ENGINE MOUNT CONTROL SOLENOID VALVE

Refer to [EC-442. "Component Inspection"](#).

Is the inspection result normal?

YES >> GO TO 7.

NO >> Replace electronic controlled engine mount control solenoid valve.

7. CHECK ELECTRONIC CONTROLLED ENGINE MOUNT

1. Turn ignition switch OFF.
2. Install vacuum pump (A) to electronic controlled engine mount (1).
3. Check that a vacuum is maintained when applying the vacuum of -40 kPa (-0.41 kg/cm², -5.8 psi) to electronic controlled engine mount.
4. Also visually check electronic controlled engine mount.

Is the inspection result normal?

YES >> GO TO 8.

NO >> Replace electronic controlled engine mount.

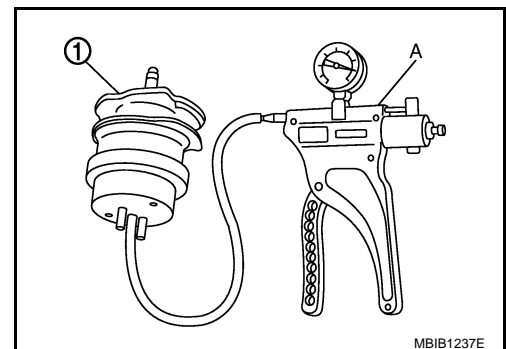

8. CHECK INTERMITTENT INCIDENT

Refer to [GI-40. "Intermittent Incident"](#).

Is the inspection result normal?

YES >> Replace intake manifold collector.

NO >> Repair or replace malfunctioning part.

Component Inspection

INFOID:000000003388255

1. CHECK ELECTRONIC CONTROLLED ENGINE MOUNT CONTROL SOLENOID VALVE

Ⓟ With CONSULT-III

1. Turn ignition switch OFF.
2. Reconnect electronic controlled engine mount control solenoid valve harness connector.
3. Disconnect vacuum hoses connected to electronic controlled engine mount control solenoid valve.
4. Turn ignition switch ON.

ELECTRONIC CONTROLLED ENGINE MOUNT

[VQ35DE]

< COMPONENT DIAGNOSIS >

5. Select "ENGINE MOUNTING" in "ACTIVE TEST" mode with CONSULT-III.
6. Check air passage continuity and operation delay time under the following conditions.

Condition (ENGINE MOUNTING)	Air passage continuity between (A) and (B)	Air passage continuity between (A) and (C)
TRVL	Existed	Not existed
IDLE	Not existed	Existed

⊗ Without CONSULT-III

1. Turn ignition switch OFF.
2. Disconnect electronic controlled engine mount control solenoid valve harness connector.
3. Disconnect vacuum hoses connected to electronic controlled engine mount control solenoid valve.
4. Check air passage continuity and operation delay time under the following conditions.

Condition	Air passage continuity between (A) and (B)	Air passage continuity between (A) and (C)
12 V direct current supply between terminals 1 and 2	Existed	Not existed
No supply	Not existed	Existed

Is the inspection result normal?

- YES >> INSPECTION END
 NO >> Replace electronic controlled engine mount control solenoid valve.

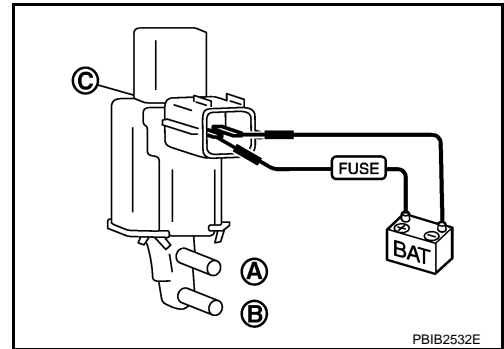
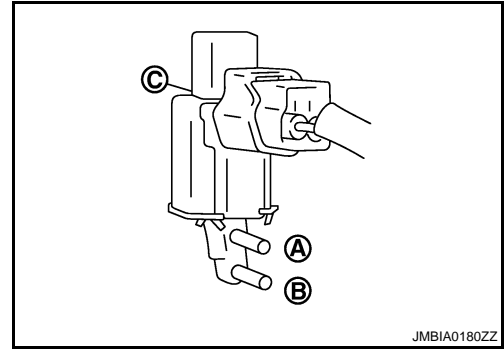

A
EC
C
D
E
F
G
H
I
J
K
L
M
N
O
P

FUEL INJECTOR

Description

INFOID:000000003388256

The fuel injector is a small, precise solenoid valve. When the ECM supplies a ground to the fuel injector circuit, the coil in the fuel injector is energized. The energized coil pulls the ball valve back and allows fuel to flow through the fuel injector into the intake manifold. The amount of fuel injected depends upon the injection pulse duration. Pulse duration is the length of time the fuel injector remains open. The ECM controls the injection pulse duration based on engine fuel needs.

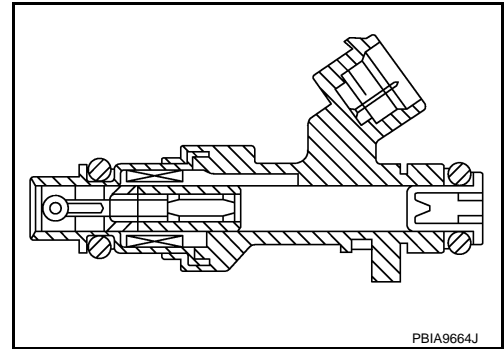

Component Function Check

INFOID:000000003388257

1. INSPECTION START

Turn ignition switch to START.

Are any cylinders ignited?

YES >> GO TO 2.

NO >> Go to [EC-444, "Diagnosis Procedure"](#).

2. CHECK FUEL INJECTOR FUNCTION

With CONSULT-III

1. Start engine.
2. Perform "POWER BALANCE" in "ACTIVE TEST" mode with CONSULT-III.
3. Check that each circuit produces a momentary engine speed drop.

Without CONSULT-III

1. Start engine.
2. Listen to each fuel injector operating sound.

Clicking sound should be heard.

Is the inspection result normal?

YES >> INSPECTION END

NO >> Go to [EC-444, "Diagnosis Procedure"](#).

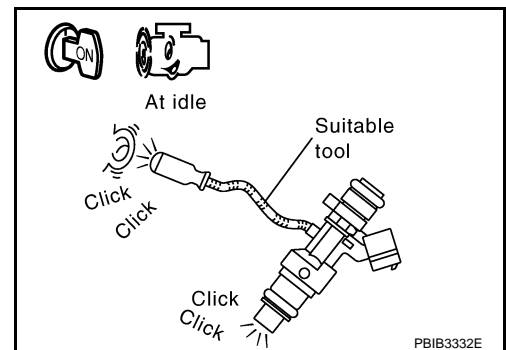

Diagnosis Procedure

INFOID:000000003388258

1. CHECK FUEL INJECTOR POWER SUPPLY CIRCUIT

1. Turn ignition switch OFF.
2. Disconnect fuel injector harness connector.
3. Turn ignition switch ON.
4. Check the voltage between fuel injector harness connector and ground.

FUEL INJECTOR

< COMPONENT DIAGNOSIS >

[VQ35DE]

Fuel injector			Ground	Voltage
Cylinder	Connector	Terminal		
1	F37	1	Ground	Battery voltage
2	F38	1		
3	F39	1		
4	F40	1		
5	F41	1		
6	F42	1		

Is the inspection result normal?

YES >> GO TO 3.

NO >> GO TO 2.

2.DETECT MALFUNCTIONING PART

Check the following.

- 10 A fuse (No.44)
- IPDM E/R harness connector F12
- Harness for open or short between fuel injector and IPDM E/R

>> Repair open circuit, short to ground or short to power in harness or connectors.

3.CHECK FUEL INJECTOR OUTPUT SIGNAL CIRCUIT FOR OPEN AND SHORT

1. Turn ignition switch OFF.
2. Disconnect ECM harness connector.
3. Check the continuity between fuel injector harness connector and ECM harness connector.

Fuel injector			ECM		Continuity
Cylinder	Connector	Terminal	Connector	Terminal	
1	F37	2	F7	32	Existed
2	F38	2		31	
3	F39	2		30	
4	F40	2		29	
5	F41	2		3	
6	F42	2		1	

4. Also check harness for short to ground and short to power.

Is the inspection result normal?

YES >> GO TO 4.

NO >> Repair open circuit, short to ground or short to power in harness or connectors.

4.CHECK FUEL INJECTOR

Refer to [EC-446. "Component Inspection"](#).

Is the inspection result normal?

YES >> GO TO 5.

NO >> Replace malfunctioning fuel injector.

5.CHECK INTERMITTENT INCIDENT

Refer to [GI-40. "Intermittent Incident"](#).

Is the inspection result normal?

YES >> Replace IPDM E/R.

NO >> INSPECTION END

FUEL INJECTOR

< COMPONENT DIAGNOSIS >

[VQ35DE]

INFOID:000000003388259

Component Inspection

1. CHECK FUEL INJECTOR

1. Turn ignition switch OFF.
2. Disconnect fuel injector harness connector.
3. Check resistance between fuel injector terminals as per the following.

Terminals	Resistance
1 and 2	11.1 - 14.5 Ω [at 10 - 60°C (50 - 140°F)]

Is the inspection result normal?

- YES >> INSPECTION END
NO >> Replace malfunctioning fuel injector.

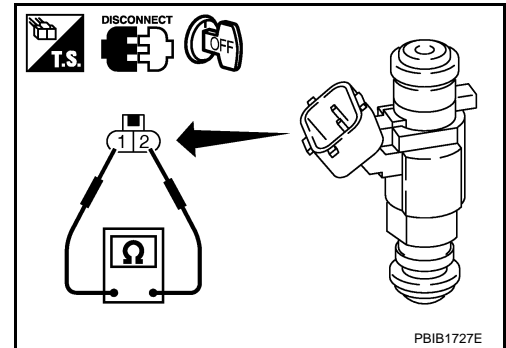

FUEL PUMP

< COMPONENT DIAGNOSIS >

[VQ35DE]

FUEL PUMP

Description

INFOID:000000003388260

Sensor	Input signal to ECM	ECM Function	Actuator
Crankshaft position sensor (POS) Camshaft position sensor (PHASE)	Engine speed*	Fuel pump control	Fuel pump relay ↓ Fuel pump
Battery	Battery voltage*		

*: ECM determines the start signal status by the signals of engine speed and battery voltage.

The ECM activates the fuel pump for several seconds after the ignition switch is turned ON to improve engine start ability. If the ECM receives a engine speed signal from the camshaft position sensor (PHASE), it knows that the engine is rotating, and causes the pump to operate. If the engine speed signal is not received when the ignition switch is ON, the engine stalls. The ECM stops pump operation and prevents battery discharging, thereby improving safety. The ECM does not directly drive the fuel pump. It controls the ON/OFF fuel pump relay, which in turn controls the fuel pump.

Condition	Fuel pump operation
Ignition switch is turned to ON.	Operates for 1 second.
Engine running and cranking	Operates.
When engine is stopped	Stops in 1.5 seconds.
Except as shown above	Stops.

Component Function Check

INFOID:000000003388261

1. CHECK FUEL PUMP FUNCTION

- Turn ignition switch ON.
- Pinch fuel feed hose with two fingers.
- ↔: Vehicle front (Illustration shows the view with intake air duct removed)

Fuel pressure pulsation should be felt on the fuel feed hose for 1 second after ignition switch is turned ON.

Is the inspection result normal?

- YES >> INSPECTION END
NO >> [EC-447. "Diagnosis Procedure"](#).

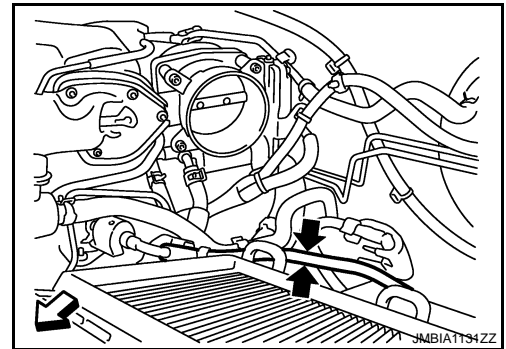

Diagnosis Procedure

INFOID:000000003388262

1. CHECK FUEL PUMP POWER SUPPLY CIRCUIT-I

- Turn ignition switch OFF.
- Disconnect ECM harness connector.
- Turn ignition switch ON.
- Check the voltage between ECM harness connector terminals.

ECM				Voltage
+		-		
Connector	Terminal	Connector	Terminal	
F7	14	E16	112	Battery voltage

Is the inspection result normal?

- YES >> GO TO 4.
NO >> GO TO 2.

FUEL PUMP

[VQ35DE]

< COMPONENT DIAGNOSIS >

2. CHECK FUEL PUMP POWER SUPPLY CIRCUIT-II

Check the voltage between IPDM E/R harness connector and ground.

IPDM E/R		Ground	Voltage
Connector	Terminal		
F12	77	Ground	Battery voltage

Is the inspection result normal?

YES >> GO TO 3.

NO >> GO TO 16.

3. DETECT MALFUNCTIONING PART

Check the following.

- IPDM E/R harness connector F12
- Harness for open or short between IPDM E/R and ECM

>> Repair open circuit, short to ground or short to power in harness or connectors.

4. CHECK CONDENSER POWER SUPPLY CIRCUIT-I

1. Turn ignition switch OFF.
2. Reconnect all harness connectors disconnected.
3. Disconnect condenser harness connector.
4. Turn ignition switch ON.
5. Check the voltage between condenser harness connector and ground.

Condenser		Ground	Voltage
Connector	Terminal		
B81	1	Ground	Battery voltage should exist for 1 second after ignition switch is turned ON.

Is the inspection result normal?

YES >> GO TO 8.

NO >> GO TO 5.

5. CHECK 15 A FUSE

1. Turn ignition switch OFF.
2. Disconnect 15 A fuse (No. 41).
3. Check 15 A fuse.

Is the inspection result normal?

YES >> GO TO 6.

NO >> Replace fuse.

6. CHECK CONDENSER POWER SUPPLY CIRCUIT-II

1. Disconnect IPDM E/R harness connector.
2. Check the continuity between IPDM E/R harness connector and condenser harness connector.

IPDM E/R		Condenser		Continuity
Connector	Terminal	Connector	Terminal	
E10	13	B81	1	Existed

3. Also check harness for short to ground and short to power.

Is the inspection result normal?

YES >> GO TO 16.

NO >> GO TO 7.

7. DETECT MALFUNCTIONING PART

FUEL PUMP

[VQ35DE]

< COMPONENT DIAGNOSIS >

Check the following.

- Harness connectors E104, B4
- IPDM E/R connector E10
- Harness for open or short between IPDM E/R and condenser

>> Repair open circuit or short to power in harness or connectors.

8.CHECK CONDENSER GROUND CIRCUIT

1. Turn ignition switch OFF.
2. Check the continuity between condenser harness connector and ground.

Condenser		Ground	Continuity
Connector	Terminal		
B81	2	Ground	Existed

3. Also check harness for short to power.

Is the inspection result normal?

YES >> GO TO 10.

NO >> GO TO 9.

9.DETECT MALFUNCTIONING PART

Check the following.

- Harness connectors B4, E104 (with rear view monitor)
- Harness for open or short between condenser and ground

>> Repair open circuit or short to power in harness or connectors.

10.CHECK CONDENSER

Refer to [EC-450. "Component Inspection \(Condenser\)".](#)

Is the inspection result normal?

YES >> GO TO 11.

NO >> Replace condenser.

11.CHECK FUEL PUMP POWER SUPPLY CIRCUIT-III

1. Disconnect "fuel level sensor unit and fuel pump" harness connector.
2. Check harness continuity between IPDM E/R harness connector and "fuel level sensor unit and fuel pump" harness connector.

IPDM E/R		Fuel level sensor unit and fuel pump		Continuity
Connector	Terminal	Connector	Terminal	
E10	13	B40	1	Existed

Is the inspection result normal?

YES >> GO TO 13.

NO >> GO TO 12.

12.DETECT MALFUNCTIONING PART

Check the following.

- Harness connectors B4, E104
- Harness for open or short between "fuel level sensor unit and fuel pump" and IPDM E/R

>> Repair open circuit or short to power in harness or connectors.

13.CHECK FUEL PUMP GROUND CIRCUIT

1. Disconnect "fuel level sensor unit and fuel pump" harness connector.
2. Check the continuity between "fuel level sensor unit and fuel pump" harness connector and ground.

FUEL PUMP

[VQ35DE]

< COMPONENT DIAGNOSIS >

Fuel level sensor unit and fuel pump		Ground	Continuity
Connector	Terminal		
B40	3	Ground	Existed

Is the inspection result normal?

YES >> GO TO 15.

NO >> GO TO 14.

14.DETECT MALFUNCTIONING PART

Check the following.

- Harness connectors B4, E104 (with rear view monitor)
- Harness for open or short between “fuel level sensor unit and fuel pump” and ground

>> Repair open circuit or short to power in harness or connectors.

15.CHECK FUEL PUMP

Refer to [EC-450, "Component Inspection \(Fuel Pump\)"](#).

Is the inspection result normal?

YES >> GO TO 16.

NO >> Replace fuel pump.

16.CHECK INTERMITTENT INCIDENT

Refer to [GI-40, "Intermittent Incident"](#).

Is the inspection result normal?

YES >> Replace IPDM E/R.

NO >> Repair or replace harness or connectors.

Component Inspection (Fuel Pump)

INFOID:000000003388263

1.CHECK FUEL PUMP

1. Turn ignition switch OFF.
2. Disconnect “fuel level sensor unit and fuel pump” harness connector.
3. Check resistance between “fuel level sensor unit and fuel pump” terminals as per the following.

Terminals	Resistance
1 and 3	0.2 - 5.0 Ω [at 25°C (77°F)]

Is the inspection result normal?

YES >> INSPECTION END

NO >> Replace “fuel level sensor unit and fuel pump”

Component Inspection (Condenser)

INFOID:000000003388264

1.CHECK CONDENSER

1. Turn ignition switch OFF.
2. Disconnect condenser harness connector.
3. Check resistance between condenser terminals as per the following.

Terminals	Resistance
1 and 2	Above 1 M Ω [at 25°C (77°F)]

Is the inspection result normal?

YES >> INSPECTION END

NO >> Replace condenser.

IGNITION SIGNAL

< COMPONENT DIAGNOSIS >

[VQ35DE]

IGNITION SIGNAL

Description

INFOID:000000003388265

The ignition signal from the ECM is sent to and amplified by the power transistor. The power transistor turns ON and OFF the ignition coil primary circuit. This ON/OFF operation induces the proper high voltage in the coil secondary circuit.

Component Function Check

INFOID:000000003388266

1.INSPECTION START

Turn ignition switch OFF, and restart engine.

Does the engine start?

YES-1 >> With CONSULT-III: GO TO 2.

YES-2 >> Without CONSULT-III: GO TO 3.

NO >> Go to [EC-451, "Diagnosis Procedure"](#).

2.CHECK IGNITION SIGNAL FUNCTION

With CONSULT-III

1. Perform "POWER BALANCE" in "ACTIVE TEST" mode with CONSULT-III.
2. Check that each circuit produces a momentary engine speed drop.

Is the inspection result normal?

YES >> INSPECTION END

NO >> Go to [EC-451, "Diagnosis Procedure"](#).

3.CHECK IGNITION SIGNAL FUNCTION

Without CONSULT-III

1. Let engine idle.
2. Read the voltage signal between ECM harness connector terminals with an oscilloscope.

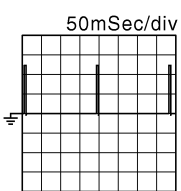
ECM				Voltage signal
+		-		
Connector	Terminal	Connector	Terminal	
F7	9	E16	112	 <p>50mSec/div</p> <p>2V/div</p> <p>JMBIA0035GB</p>
	10			
	11			
	18			
	19			
	21			

NOTE:

The pulse cycle changes depending on rpm at idle.

Is the inspection result normal?

YES >> INSPECTION END

NO >> Go to [EC-451, "Diagnosis Procedure"](#).

Diagnosis Procedure

INFOID:000000003388267

1.CHECK IGNITION COIL POWER SUPPLY CIRCUIT-I

1. Turn ignition switch OFF, wait at least 10 seconds and then turn it ON.
2. Check the voltage between ECM harness connector terminals.

IGNITION SIGNAL

[VQ35DE]

< COMPONENT DIAGNOSIS >

ECM			Voltage
Connector	+	-	
	Terminal	Terminal	
E16	105	112	Battery voltage

Is the inspection result normal?

YES >> GO TO 2.

NO >> Refer to [EC-135. "Diagnosis Procedure"](#).

2.CHECK IGNITION COIL POWER SUPPLY CIRCUIT-II

1. Turn ignition switch OFF.
2. Disconnect condenser harness connector.
3. Turn ignition switch ON.
4. Check the voltage between condenser harness connector and ground.

Condenser		Ground	Voltage
Connector	Terminal		
F13	1	Ground	Battery voltage

Is the inspection result normal?

YES >> GO TO 4.

NO >> GO TO 3.

3.CHECK IGNITION COIL POWER SUPPLY CIRCUIT-III

1. Turn ignition switch OFF.
2. Disconnect IPDM E/R harness connector.
3. Check the continuity between IPDM E/R harness connector and condenser harness connector.

IPDM E/R		Condenser		Continuity
Connector	Terminal	Connector	Terminal	
F12	49	F13	1	Existed

4. Also check harness for short to ground and short to power.

Is the inspection result normal?

YES >> Refer to [EC-135. "Diagnosis Procedure"](#).

NO >> Repair open circuit, short to ground or short to power in harness or connectors.

4.CHECK CONDENSER GROUND CIRCUIT FOR OPEN AND SHORT

1. Turn ignition switch OFF.
2. Check the continuity between condenser harness connector and ground.

Condenser		Ground	Continuity
Connector	Terminal		
F13	2	Ground	Existed

3. Also check harness for short to power.

Is the inspection result normal?

YES >> GO TO 5.

NO >> Repair open circuit or short to power in harness or connectors.

5.CHECK CONDENSER

Refer to [EC-455. "Component Inspection \(Condenser\)"](#)

Is the inspection result normal?

YES >> GO TO 6.

NO >> Replace condenser.

IGNITION SIGNAL

[VQ35DE]

< COMPONENT DIAGNOSIS >

6. CHECK IGNITION COIL POWER SUPPLY CIRCUIT-V

1. Reconnect all harness connectors disconnected.
2. Disconnect ignition coil harness connector.
3. Turn ignition switch ON.
4. Check the voltage between ignition coil harness connector and ground.

Ignition coil			Ground	Voltage
Cylinder	Connector	Terminal		
1	F31	3	Ground	Battery voltage
2	F32	3		
3	F33	3		
4	F34	3		
5	F35	3		
6	F36	3		

Is the inspection result normal?

YES >> GO TO 7.

NO >> Repair or replace harness or connectors.

7. CHECK IGNITION COIL GROUND CIRCUIT FOR OPEN AND SHORT

1. Turn ignition switch OFF.
2. Check the continuity between ignition coil harness connector and ground.

Ignition coil			Ground	Continuity
Cylinder	Connector	Terminal		
1	F31	2	Ground	Existed
2	F32	2		
3	F33	2		
4	F34	2		
5	F35	2		
6	F36	2		

3. Also check harness for short to power.

Is the inspection result normal?

YES >> GO TO 8.

NO >> Repair open circuit or short to power in harness or connectors.

8. CHECK IGNITION COIL OUTPUT SIGNAL CIRCUIT FOR OPEN AND SHORT

1. Disconnect ECM harness connector.
2. Check the continuity between ignition coil harness connector and ECM harness connector.

Ignition coil			ECM		Continuity
Cylinder	Connector	Terminal	Connector	Terminal	
1	F31	1	F7	11	Existed
2	F32	1		10	
3	F33	1		9	
4	F34	1		21	
5	F35	1		19	
6	F36	1		18	

3. Also check harness for short to ground and short to power.

Is the inspection result normal?

IGNITION SIGNAL

[VQ35DE]

< COMPONENT DIAGNOSIS >

- YES >> GO TO 9.
NO >> Repair open circuit, short to ground or short to power in harness or connectors.

9. CHECK IGNITION COIL WITH POWER TRANSISTOR

Refer to [EC-454, "Component Inspection \(Ignition Coil with Power Transistor\)"](#).

Is the inspection result normal?

- YES >> GO TO 10.
NO >> Replace malfunctioning ignition coil with power transistor.

10. CHECK INTERMITTENT INCIDENT

Refer to [GI-40, "Intermittent Incident"](#).

>> INSPECTION END

Component Inspection (Ignition Coil with Power Transistor)

INFOID:000000003388268

1. CHECK IGNITION COIL WITH POWER TRANSISTOR-I

1. Turn ignition switch OFF.
2. Disconnect ignition coil harness connector.
3. Check resistance between ignition coil terminals as per the following.

Terminal No. (Polarity)	Resistance Ω [at 25°C (77°F)]
1 and 2	Except 0 or ∞
1 and 3	Except 0
2 and 3	

Is the inspection result normal?

- YES >> GO TO 2.
NO >> Replace malfunctioning ignition coil with power transistor.

2. CHECK IGNITION COIL WITH POWER TRANSISTOR-II

CAUTION:

Perform the following procedure in a place with no combustible objects and good ventilation.

1. Turn ignition switch OFF.
2. Reconnect all harness connectors disconnected.
3. Remove fuel pump fuse in IPDM E/R to release fuel pressure.

NOTE:

Do not use CONSULT-III to release fuel pressure, or fuel pressure applies again during the following procedure.

4. Start engine.
5. After engine stalls, crank it 2 or 3 times to release all fuel pressure.
6. Turn ignition switch OFF.
7. Remove all ignition coil harness connectors to avoid the electrical discharge from the ignition coils.
8. Remove ignition coil and spark plug of the cylinder to be checked.
9. Crank engine for 5 seconds or more to remove combustion gas in the cylinder.
10. Connect spark plug and harness connector to ignition coil.
11. Fix ignition coil using a rope etc. with gap of 13 - 17 mm (0.52 - 0.66 in) between the edge of the spark plug and grounded metal portion as shown in the figure.
12. Crank engine for approximately 3 seconds, and check whether spark is generated between the spark plug and the grounded metal portion.

Spark should be generated.

CAUTION:

- During the operation, always stay 0.5 m (19.7 in) or more away from the spark plug and the ignition coil. Be careful

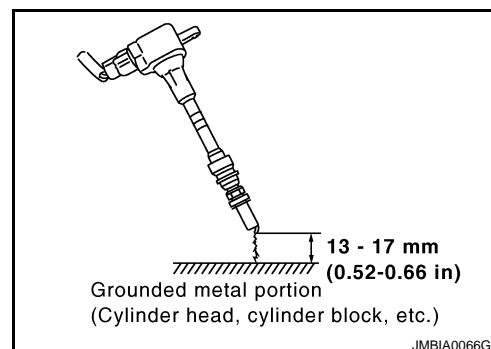

IGNITION SIGNAL

< COMPONENT DIAGNOSIS >

[VQ35DE]

not to get an electrical shock while checking, because the electrical discharge voltage becomes 20 kV or more.

- It might cause to damage the ignition coil if the gap of more than 17 mm (0.66 in) is taken.

NOTE:

When the gap is less than 13 mm (0.52 in), the spark might be generated even if the coil is malfunctioning.

Is the inspection result normal?

YES >> INSPECTION END

NO >> Replace malfunctioning ignition coil with power transistor.

Component Inspection (Condenser)

INFOID:000000003388269

1. CHECK CONDENSER

1. Turn ignition switch OFF.
2. Disconnect condenser harness connector.
3. Check resistance between condenser terminals as per the following.

Terminals	Resistance
1 and 2	Above 1 MΩ [at 25C° (77C°)]

Is the inspection result normal?

YES >> INSPECTION END

NO >> Replace condenser.

A
EC
C
D
E
F
G
H
I
J
K
L
M
N
O
P

MALFUNCTION INDICATOR LAMP

[VQ35DE]

< COMPONENT DIAGNOSIS >

MALFUNCTION INDICATOR LAMP

Description

INFOID:000000003388270

The Malfunction Indicator Lamp (MIL) is located on the combination meter.

The MIL will illuminate when the ignition switch is turned ON without the engine running. This is a bulb check.

When the engine is started, the MIL should turn off. If the MIL remains on, the on board diagnostic system has detected an engine system malfunction.

For details, refer to [EC-102. "Diagnosis Description"](#).

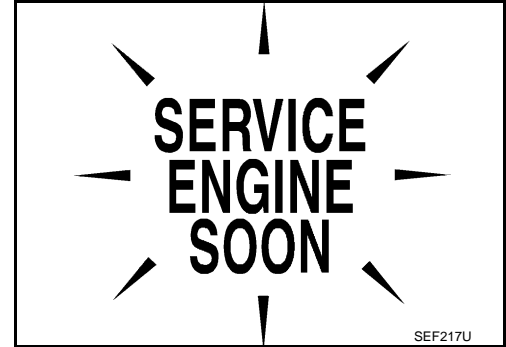

Component Function Check

INFOID:000000003388271

1. CHECK MIL FUNCTION

1. Turn ignition switch ON.
2. Check that MIL illuminates.

Is the inspection result normal?

- YES >> INSPECTION END
- NO >> Go to [EC-456. "Diagnosis Procedure"](#).

Diagnosis Procedure

INFOID:000000003388272

1. CHECK DTC

Check that DTC UXXXX is not displayed.

Is the inspection result normal?

- YES >> GO TO 2.
- NO >> Perform trouble diagnosis for DTC UXXXX.

2. CHECK COMBINATION METER FUNCTION

Refer to [MWI-34. "CONSULT-III Function \(METER/M&A\)"](#).

Is the inspection result normal?

- YES >> GO TO 3.
- NO >> Repair or replace.

3. CHECK INTERMITTENT INCIDENT

Refer to [GI-40. "Intermittent Incident"](#).

Is the inspection result normal?

- YES >> Replace combination meter.
- NO >> Repair or replace.

ON BOARD REFUELING VAPOR RECOVERY (ORVR)

< COMPONENT DIAGNOSIS >

[VQ35DE]

ON BOARD REFUELING VAPOR RECOVERY (ORVR)

Description

INFOID:000000003388273

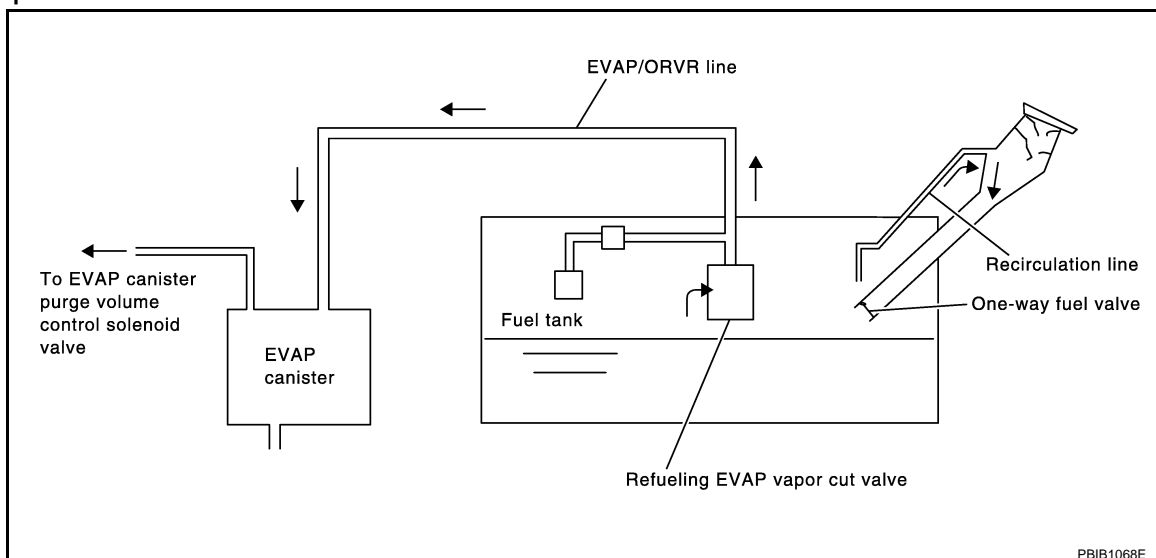

From the beginning of refueling, the air and vapor inside the fuel tank go through refueling EVAP vapor cut valve and EVAP/ORVR line to the EVAP canister. The vapor is absorbed by the EVAP canister and the air is released to the atmosphere.

When the refueling has reached the full level of the fuel tank, the refueling EVAP vapor cut valve is closed and refueling is stopped because of auto shut-off. The vapor which was absorbed by the EVAP canister is purged during driving.

WARNING:

When conducting inspections below, be sure to observe the following:

- Put a "CAUTION: FLAMMABLE" sign in workshop.
- Never smoke while servicing fuel system. Keep open flames and sparks away from work area.
- Always to furnish the workshop with a CO₂ fire extinguisher.

CAUTION:

- Before removing fuel line parts, carry out the following procedures:
 - Put drained fuel in an explosion-proof container and put lid on securely.
 - Release fuel pressure from fuel line. Refer to [EC-545, "Inspection"](#).
 - Disconnect battery ground cable.
- Always replace O-ring when the fuel gauge retainer is removed.
- Never kink or twist hose and tube when they are installed.
- Never tighten hose and clamps excessively to avoid damaging hoses.
- After installation, run engine and check for fuel leakage at connections.
- Never attempt to top off the fuel tank after the fuel pump nozzle shuts off automatically. Continued refueling may cause fuel overflow, resulting in fuel spray and possibly a fire.

Component Function Check

INFOID:000000003388274

1. CHECK ORVR FUNCTION

Check whether the following symptoms are present.

- Fuel odor from EVAP canister is strong.
- Cannot refuel/Fuel odor from the fuel filler opening is strong while refueling.

Are any symptoms present?

- YES >> Go to [EC-457, "Diagnosis Procedure"](#).
- NO >> INSPECTION END

Diagnosis Procedure

INFOID:000000003388275

1. INSPECTION START

Check whether the following symptoms are present.

- A: Fuel odor from EVAP canister is strong.

ON BOARD REFUELING VAPOR RECOVERY (ORVR)

[VQ35DE]

< COMPONENT DIAGNOSIS >

B: Cannot refuel/Fuel odor from the fuel filler opening is strong while refueling.

A or B

- A >> GO TO 2.
- B >> GO TO 7.

2.CHECK EVAP CANISTER

1. Remove EVAP canister with EVAP canister vent control valve and EVAP control system pressure sensor attached.
2. Weigh the EVAP canister with EVAP canister vent control valve and EVAP control system pressure sensor attached.

The weight should be less than 2.1 kg (4.6 lb).

Is the inspection result normal?

- YES >> GO TO 3.
- NO >> GO TO 4.

3.CHECK IF EVAP CANISTER IS SATURATED WITH WATER

Check if water will drain from EVAP canister

Does water drain from the EVAP canister?

- YES >> GO TO 4.
- NO >> GO TO 6.

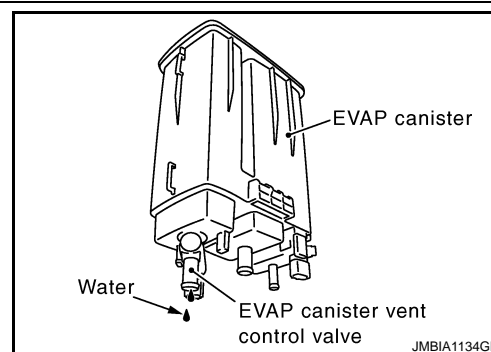

4.REPLACE EVAP CANISTER

Replace EVAP canister with a new one.

>> GO TO 5.

5.DETECT MALFUNCTIONING PART

Check the EVAP hose between EVAP canister and vehicle frame for clogging or poor connection.

>> Repair or replace EVAP hose.

6.CHECK REFUELING EVAP VAPOR CUT VALVE

Refer to [EC-460, "Component Inspection"](#).

Is the inspection result normal?

- YES >> INSPECTION END
- NO >> Replace refueling EVAP vapor cut valve with fuel tank.

7.CHECK EVAP CANISTER

1. Remove EVAP canister with EVAP canister vent control valve and EVAP control system pressure sensor attached.
2. Weigh the EVAP canister with EVAP canister vent control valve and EVAP control system pressure sensor attached.

The weight should be less than 2.1 kg (4.6 lb).

Is the inspection result normal?

- YES >> GO TO 8.
- NO >> GO TO 9.

8.CHECK IF EVAP CANISTER IS SATURATED WITH WATER

ON BOARD REFUELING VAPOR RECOVERY (ORVR)

[VQ35DE]

< COMPONENT DIAGNOSIS >

Check if water will drain from EVAP canister.

Does water drain from the EVAP canister?

- YES >> GO TO 6.
- NO >> GO TO 11.

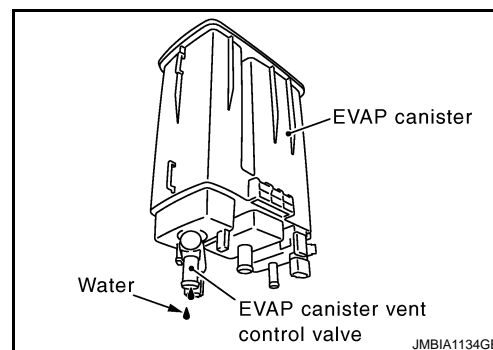

9.REPLACE EVAP CANISTER

Replace EVAP canister with a new one.

>> GO TO 10.

10.DETECT MALFUNCTIONING PART

Check the EVAP hose between EVAP canister and vehicle frame for clogging or poor connection.

>> Repair or replace EVAP hose.

11.CHECK VENT HOSES AND VENT TUBES

Check hoses and tubes between EVAP canister and refueling control valve for clogging, kinks, looseness and improper connection.

Is the inspection result normal?

- YES >> GO TO 12.
- NO >> Repair or replace hoses and tubes.

12.CHECK FILLER NECK TUBE

Check recirculation line for clogging, dents and cracks.

Is the inspection result normal?

- YES >> GO TO 13.
- NO >> Replace filler neck tube.

13.CHECK REFUELING EVAP VAPOR CUT VALVE

Refer to [EC-460. "Component Inspection"](#).

Is the inspection result normal?

- YES >> GO TO 14.
- NO >> Replace refueling EVAP vapor cut valve with fuel tank.

14.CHECK FUEL FILLER TUBE

Check filler neck tube and hose connected to the fuel tank for clogging, dents and cracks.

Is the inspection result normal?

- YES >> GO TO 15.
- NO >> Replace fuel filler tube.

15.CHECK ONE-WAY FUEL VALVE-I

Check one-way valve for clogging.

Is the inspection result normal?

- YES >> GO TO 16.
- NO >> Repair or replace one-way fuel valve with fuel tank.

16.CHECK ONE-WAY FUEL VALVE-II

1. Check that fuel is drained from the tank.
2. Remove fuel filler tube and hose.

ON BOARD REFUELING VAPOR RECOVERY (ORVR)

[VQ35DE]

< COMPONENT DIAGNOSIS >

3. Check one-way fuel valve for operation as per the following.
When a stick is inserted, the valve should open, when removing stick it should close.

Do not drop any material into the tank.

Is the inspection result normal?

YES >> INSPECTION END

NO >> Replace fuel filler tube or replace one-way fuel valve with fuel tank.

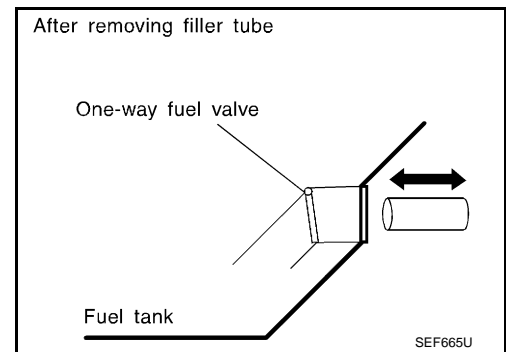

INFOID:000000003388276

Component Inspection

1.INSPECTION START

Will CONSULT-III be used?

Will CONSULT-III be used?

YES >> GO TO 2.

NO >> GO TO 3.

2.CHECK REFUELING EVAP VAPOR CUT VALVE

 **With CONSULT-III**

1. Turn ignition switch OFF.
 2. Remove fuel tank. Refer to [FL-12. "Removal and Installation"](#).
 3. Drain fuel from the tank as per the following:
 - Remove fuel feed hose located on the fuel gauge retainer.
 - Connect a spare fuel hose, one side to fuel gauge retainer where the hose was removed and the other side to a fuel container.
 - Drain fuel using "FUEL PUMP RELAY" in "ACTIVE TEST" mode with CONSULT-III.
 4. Check refueling EVAP vapor cut valve for being stuck to close as per the following.
Blow air into the refueling EVAP vapor cut valve (from the end of EVAP/ORVR line hose), and check that the air flows freely into the tank.
 5. Check refueling EVAP vapor cut valve for being stuck to open as per the following.
 - Connect vacuum pump to hose end.
 - Remove fuel gauge retainer with fuel gauge unit.
- Always replace O-ring with new one.**
- Turn fuel tank upside down.
 - Apply vacuum pressure to hose end [-13.3 kPa (-0.136 kg/cm³, -1.93 psi)] with fuel gauge retainer remaining open and check that the pressure is applicable.

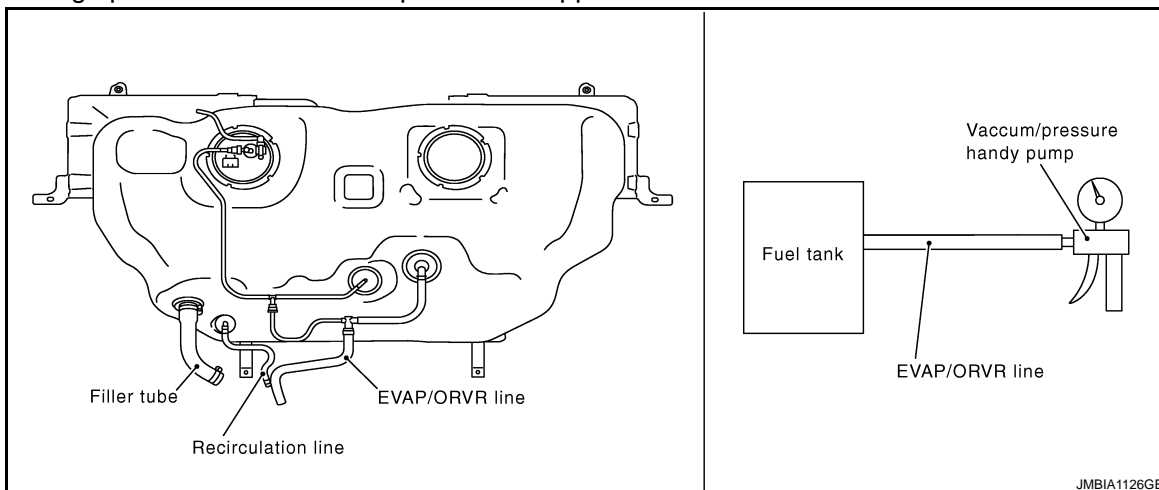

Is the inspection result normal?

YES >> INSPECTION END

NO >> Replace refueling EVAP vapor cut valve with fuel tank.

ON BOARD REFUELING VAPOR RECOVERY (ORVR)

< COMPONENT DIAGNOSIS >

[VQ35DE]

3. CHECK REFUELING EVAP VAPOR CUT VALVE

⊗ Without CONSULT-III

1. Turn ignition switch OFF.
2. Remove fuel tank. Refer to [FL-12, "Removal and Installation"](#).
3. Drain fuel from the tank as per the following:
 - Remove fuel gauge retainer.
 - Drain fuel from the tank using a handy pump into a fuel container.
4. Check refueling EVAP vapor cut valve for being stuck to close as per the following.
Blow air into the refueling EVAP vapor cut valve (from the end of EVAP/ORVR line hose), and check that the air flows freely into the tank.
5. Check refueling EVAP vapor cut valve for being stuck to open as per the following.
 - Connect vacuum pump to hose end.
 - Remove fuel gauge retainer with fuel gauge unit.

Always replace O-ring with new one.

- Turn fuel tank upside down.
- Apply vacuum pressure to hose end [-13.3 kPa (-0.136 kg/cm^3 , -1.93 psi)] with fuel gauge retainer remaining open and check that the pressure is applicable.

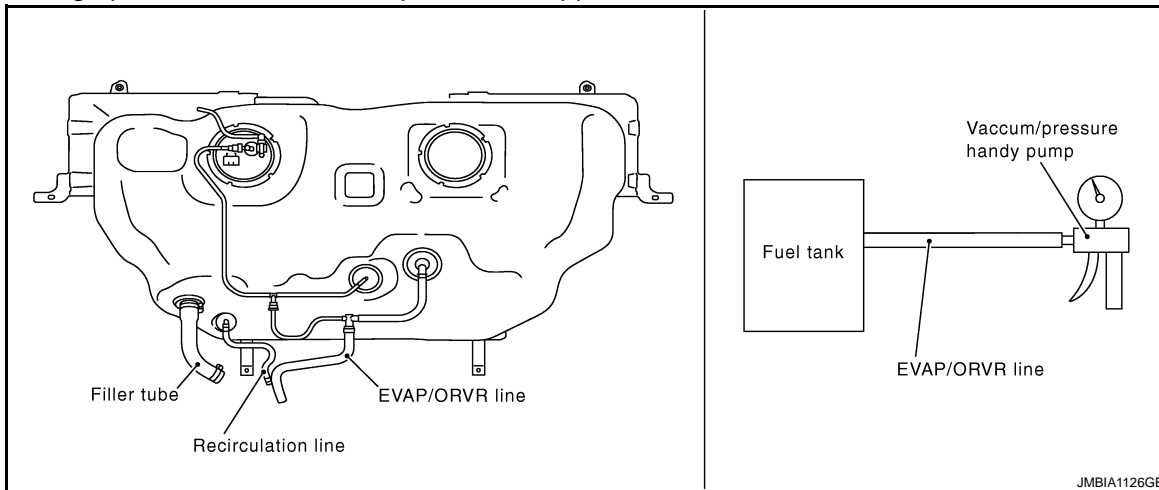

Is the inspection result normal?

- YES >> INSPECTION END
- NO >> Replace refueling EVAP vapor cut valve with fuel tank.

POSITIVE CRANKCASE VENTILATION

< COMPONENT DIAGNOSIS >

[VQ35DE]

POSITIVE CRANKCASE VENTILATION

Description

INFOID:000000003388277

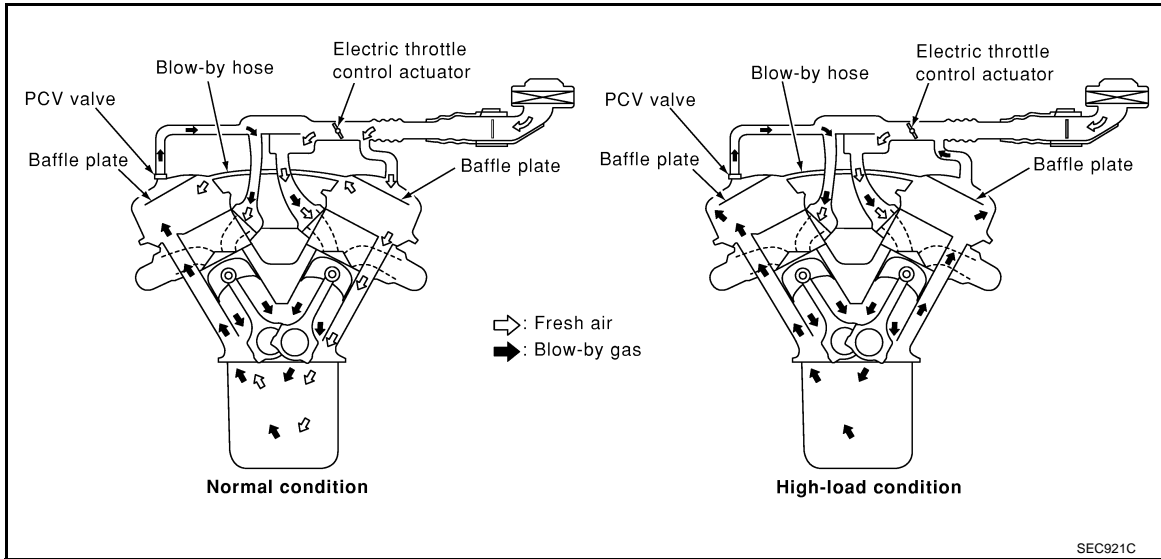

This system returns blow-by gas to the intake manifold.

The positive crankcase ventilation (PCV) valve is provided to conduct crankcase blow-by gas to the intake manifold.

During partial throttle operation of the engine, the intake manifold sucks the blow-by gas through the PCV valve.

Normally, the capacity of the valve is sufficient to handle any blow-by and a small amount of ventilating air.

The ventilating air is drawn from the air inlet tubes into the crankcase. In this process the air passes through the hose connecting air inlet tubes to rocker cover.

Under full-throttle condition, the manifold vacuum is insufficient to draw the blow-by flow through the valve. The flow goes through the hose connection in the reverse direction.

On vehicles with an excessively high blow-by, the valve does not meet the requirement. This is because some of the flow will go through the hose connection to the air inlet tubes under all conditions.

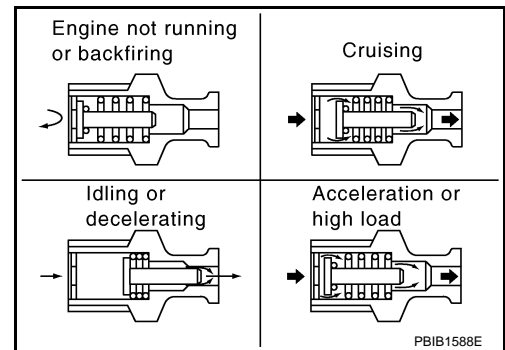

Component Inspection

INFOID:000000003388278

1. CHECK PCV VALVE

With engine running at idle, remove PCV valve from rocker cover. A properly working valve makes a hissing noise as air passes through it. A strong vacuum should be felt immediately when a finger is placed over valve inlet.

Is the inspection result normal?

YES >> INSPECTION END

NO >> Replace PCV valve.

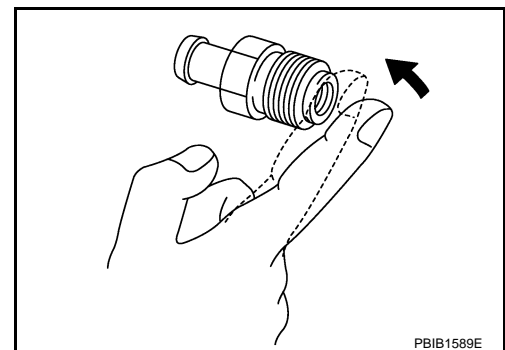

REFRIGERANT PRESSURE SENSOR

< COMPONENT DIAGNOSIS >

[VQ35DE]

REFRIGERANT PRESSURE SENSOR

Description

INFOID:000000003388279

The refrigerant pressure sensor is installed at the condenser of the air conditioner system. The sensor uses an electrostatic volume pressure transducer to convert refrigerant pressure to voltage. The voltage signal is sent to ECM, and ECM controls cooling fan system.

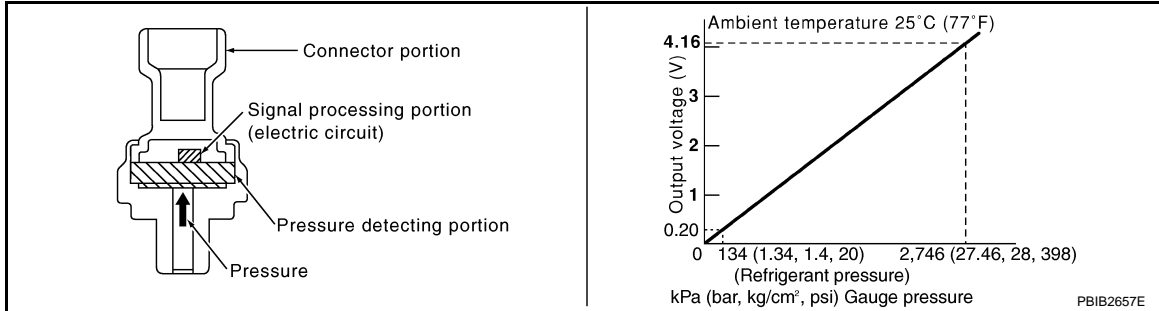

Component Function Check

INFOID:000000003388280

1. CHECK REFRIGERANT PRESSURE SENSOR FUNCTION

1. Start engine and warm it up to normal operating temperature.
2. Turn A/C switch and blower fan switch ON.
3. Check the voltage between ECM harness connector terminals under the following conditions.

Connector	ECM		Voltage (V)
	+	-	
	Terminal	Terminal	
F8	39 (Refrigerant pressure sensor signal)	40 (Sensor ground)	1.0 - 4.0

Is the inspection result normal?

- YES >> INSPECTION END
 NO >> Go to [EC-463, "Diagnosis Procedure"](#).

Diagnosis Procedure

INFOID:000000003388281

1. CHECK GROUND CONNECTION

1. Turn A/C switch and blower fan switch OFF.
2. Turn ignition switch OFF.
3. Check ground connection E38. Refer to Ground Inspection in [GI-43, "Circuit Inspection"](#).

Is the inspection result normal?

- YES >> GO TO 2.
 NO >> Repair or replace ground connection.

2. CHECK REFRIGERANT PRESSURE SENSOR POWER SUPPLY CIRCUIT

1. Disconnect refrigerant pressure sensor harness connector.
2. Turn ignition switch ON.
3. Check the voltage between refrigerant pressure sensor harness connector and ground.

Refrigerant pressure sensor		Ground	Voltage (V)
Connector	Terminal		
E300	1	Ground	Approx. 5

Is the inspection result normal?

- YES >> GO TO 4.
 NO >> GO TO 3.

REFRIGERANT PRESSURE SENSOR

[VQ35DE]

< COMPONENT DIAGNOSIS >

3. DETECT MALFUNCTIONING PART

Check the following.

- Harness connectors F123, E6
- IPDM E/R harness connectors E10, E346
- Harness for open or short between ECM and refrigerant pressure sensor

>> Repair open circuit, short to ground or short to power in harness or connectors.

4. CHECK REFRIGERANT PRESSURE SENSOR GROUND CIRCUIT FOR OPEN AND SHORT

1. Turn ignition switch OFF.
2. Disconnect ECM harness connector.
3. Check the continuity between refrigerant pressure sensor harness connector and ECM harness connector.

Refrigerant pressure sensor		ECM		Continuity
Connector	Terminal	Connector	Terminal	
E300	3	F8	40	Existed

4. Also check harness for short to ground and short to power.

Is the inspection result normal?

YES >> GO TO 6.

NO >> GO TO 5.

5. DETECT MALFUNCTIONING PART

Check the following.

- Harness connectors F123, E6
- IPDM E/R harness connectors E10, E346
- Harness for open or short between ECM and refrigerant pressure sensor

>> Repair open circuit, short to ground or short to power in harness or connectors.

6. CHECK REFRIGERANT PRESSURE SENSOR INPUT SIGNAL CIRCUIT FOR OPEN AND SHORT

1. Check the continuity between refrigerant pressure sensor harness connector and ECM harness connector.

Refrigerant pressure sensor		ECM		Continuity
Connector	Terminal	Connector	Terminal	
E300	2	F8	39	Existed

2. Also check harness for short to ground and short to power.

Is the inspection result normal?

YES >> GO TO 8.

NO >> GO TO 7.

7. DETECT MALFUNCTIONING PART

Check the following.

- Harness connectors F123, E6
- IPDM E/R harness connectors E10, E346
- Harness for open or short between ECM and refrigerant pressure sensor

>> Repair open circuit, short to ground or short to power in harness or connectors.

8. CHECK INTERMITTENT INCIDENT

Refer to [GI-40, "Intermittent Incident"](#).

Is the inspection result normal?

YES >> Replace refrigerant pressure sensor.

REFRIGERANT PRESSURE SENSOR

< COMPONENT DIAGNOSIS >

[VQ35DE]

NO >> Repair or replace malfunctioning part.

A

EC

C

D

E

F

G

H

I

J

K

L

M

N

O

P

VARIABLE INDUCTION AIR SYSTEM

< COMPONENT DIAGNOSIS >

[VQ35DE]

VARIABLE INDUCTION AIR SYSTEM

Description

INFOID:000000003388282

Power Valves 1 and 2

The power valves 1 and 2 are installed in intake manifold collector and used to control the suction passage of the variable induction air control system. They are set in the fully closed or fully opened position by the power valve actuators 1 and 2 operated by the vacuum stored in the vacuum tank. The vacuum to power valve actuators is controlled by the VIAS control solenoid valves 1 and 2.

Component Function Check

INFOID:000000003388283

1. CHECK OVERALL FUNCTION-I

Ⓟ With CONSULT-III

1. Start engine and warm it up to the normal operating temperature.
2. Perform "VIAS S/V-1" in "ACTIVE TEST" mode with CONSULT-III.
3. Turn VIAS control solenoid valve 1 "ON" and "OFF", and check that power valve actuator 1 rod moves.

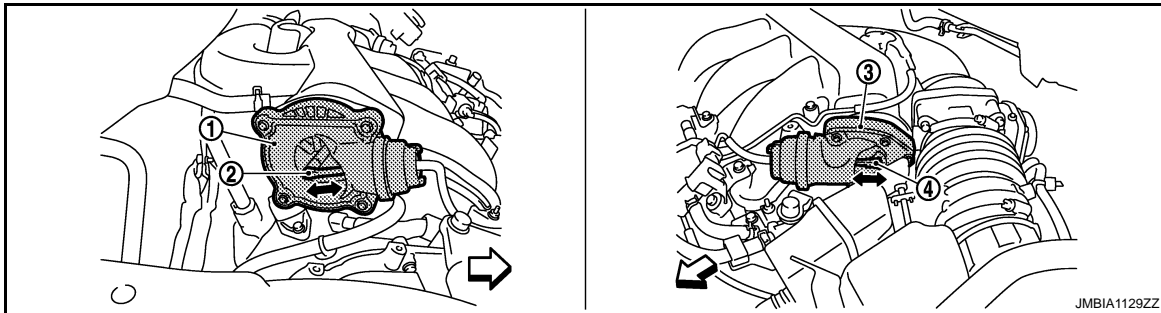

1. Power valve actuator 1
2. Power valve actuator 1 rod
3. Power valve actuator 2
4. Power valve actuator 2 rod

↶ : Vehicle front

ⓧ Without CONSULT-III

1. Start engine and warm it up to the normal operating temperature.
2. Rev engine quickly up to approximately 5,000 rpm.
3. Check that power valve actuator 1 rod moves.

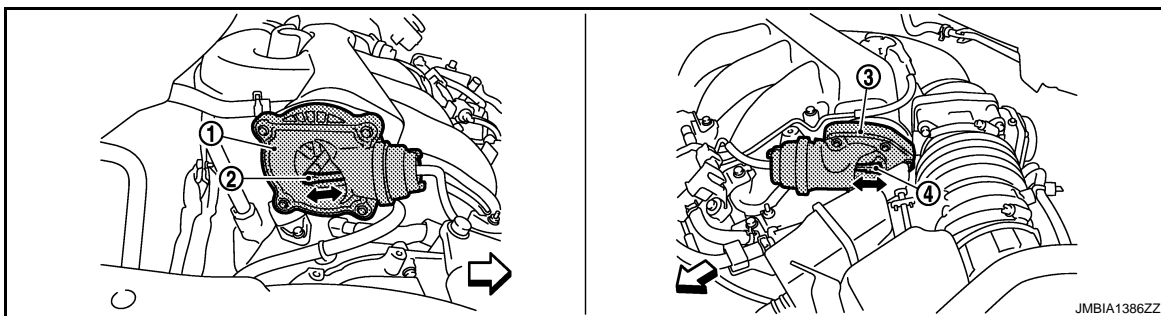

1. Power valve actuator 1
2. Power valve actuator 1 rod
3. Power valve actuator 2
4. Power valve actuator 2 rod

↶ : Vehicle front

Is the inspection result normal?

- YES >> GO TO 2.
NO >> [EC-467, "Diagnosis Procedure"](#).

2. CHECK OVERALL FUNCTION-II

Ⓟ With CONSULT-III

VARIABLE INDUCTION AIR SYSTEM

[VQ35DE]

< COMPONENT DIAGNOSIS >

1. Perform "VIAS S/V-2" in "ACTIVE TEST" mode with CONSULT-III.
2. Turn VIAS control solenoid valve 2 "ON" and "OFF", and check that power valve actuator 2 rod moves.

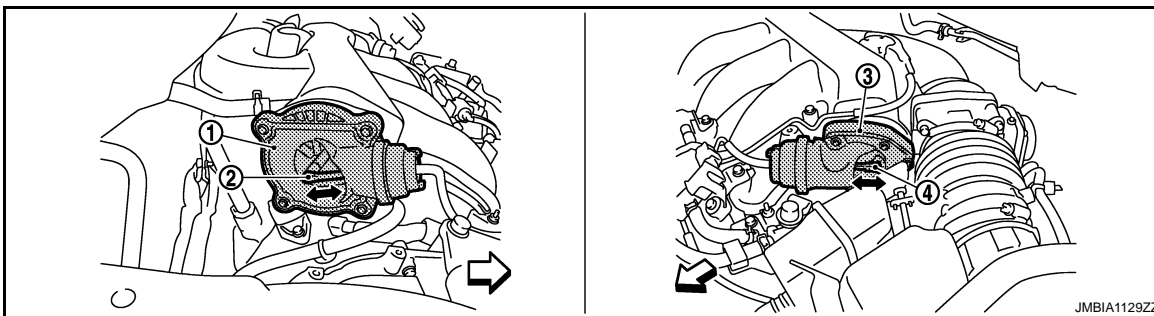

1. Power valve actuator 1
 2. Power valve actuator 1 rod
 3. Power valve actuator 2
 4. Power valve actuator 2 rod
- ↶ : Vehicle front

⊗ Without CONSULT-III

1. When revving engine up to 5,000 rpm quickly.
2. Rev engine quickly up to approximately 5,000 rpm.
3. Check that power valve actuator 2 rod moves.

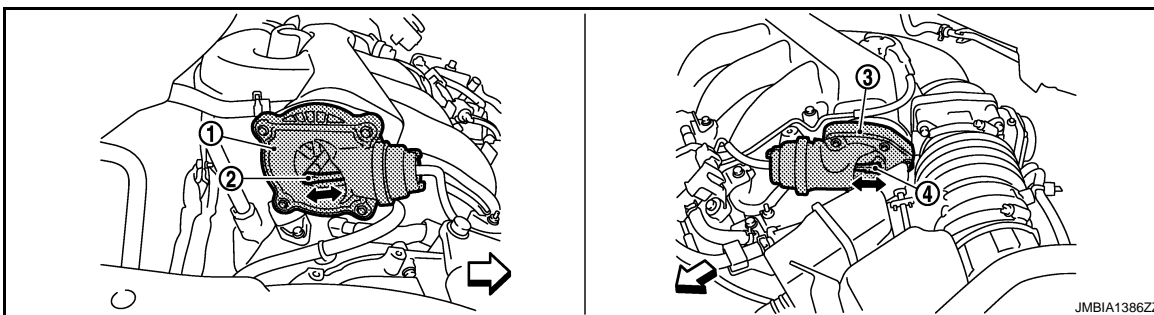

1. Power valve actuator 1
 2. Power valve actuator 1 rod
 3. Power valve actuator 2
 4. Power valve actuator 2 rod
- ↶ : Vehicle front

Is the inspection result normal?

- YES >> INSPECTION END
NO >> [EC-467. "Diagnosis Procedure"](#).

Diagnosis Procedure

INFOID:000000003388284

1. INSPECTION START

Confirm the malfunctioning system (power valve 1 or power valve 2). Refer to [EC-466. "Component Function Check"](#).

Which system is related to the incident?

- Power valve 1 >> GO TO 2.
Power valve 2 >> GO TO 6.

2. CHECK VACUUM EXISTENCE-I

Ⓜ With CONSULT-III

1. Stop engine and disconnect vacuum hose connected to power valve actuator 1.
2. Start engine and let it idle.
3. Perform "VIAS S/V-1" in "ACTIVE TEST" mode with CONSULT-III.
4. Turn VIAS control solenoid valve 1 ON and OFF, and check vacuum existence under the following conditions.

VARIABLE INDUCTION AIR SYSTEM

< COMPONENT DIAGNOSIS >

[VQ35DE]

VIAS S/V-1	Vacuum
ON	Existed
OFF	Not existed

⊗ Without CONSULT-III

1. Stop engine and disconnect vacuum hose connected to power valve actuator 1.
2. Disconnect VIAS control solenoid valve 1 harness connector.
3. Start engine.
4. Rev engine quickly up to approximately 5,000 rpm.
5. Check vacuum existence under the following conditions.

Condition	Vacuum
Idle	Existed
Rev engine quickly up to approximately 5,000 rpm	Not existed

Is the inspection result normal?

- YES >> Repair or replace power valve actuator 1.
NO >> GO TO 3.

3.CHECK VACUUM TANK

1. Stop engine and disconnect vacuum hose connected to intake manifold collector.
2. Start engine and let it idle.
3. Check vacuum existence from intake manifold collector.

Does vacuum existence from the intake manifold collector?

- YES >> GO TO 4.
NO >> Replace intake manifold collector.

4.CHECK VACUUM HOSE

1. Stop engine.
2. Check vacuum hose for crack, clogging, improper connection or disconnection. Refer to [EC-94. "System Diagram"](#).

Is the inspection result normal?

- YES >> GO TO 5.
NO >> Repair hoses or tubes.

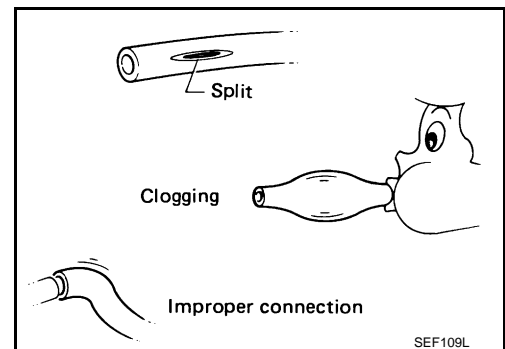

5.CHECK VIAS CONTROL SOLENOID VALVE 1

Refer to [EC-394. "Component Inspection"](#).

Is the inspection result normal?

- YES >> GO TO 9.
NO >> Replace VIAS control solenoid valve 1.

6.CHECK VACUUM EXISTENCE-II

Ⓟ With CONSULT-III

1. Stop engine and disconnect vacuum hose connected to power valve actuator 2.
2. Start engine and let it idle.
3. Perform "VIAS S/V-2" in "ACTIVE TEST" mode with CONSULT-III.
4. Turn VIAS control solenoid valve 2 ON and OFF, and check vacuum existence under the following conditions.

VARIABLE INDUCTION AIR SYSTEM

[VQ35DE]

< COMPONENT DIAGNOSIS >

VIAS S/V 2	Vacuum
ON	Existed
OFF	Not existed

⊗ Without CONSULT-III

1. Stop engine and disconnect vacuum hose connected to power valve actuator 2.
2. Disconnect VIAS control solenoid valve 1 harness connector.
3. Start engine.
4. Rev engine quickly up to approximately 5,000 rpm.
5. Check vacuum existence under the following conditions.

Condition	Operation
Idle	Existed
Rev engine quickly up to approximately 5,000 rpm	Not existed

Is the inspection result normal?

- YES >> Repair or replace power valve actuator 2.
NO >> GO TO 7.

7.CHECK VACUUM HOSE

1. Stop engine.
2. Check vacuum hose for crack, clogging, improper connection or disconnection. Refer to [EC-94. "System Diagram"](#).

Is the inspection result normal?

- YES >> GO TO 8.
NO >> Repair hoses or tubes.

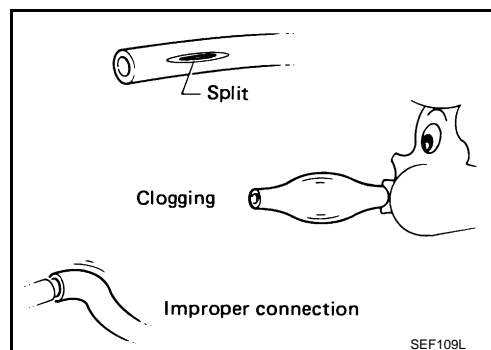

8.CHECK VIAS CONTROL SOLENOID VALVE 2

Refer to [EC-397. "Component Inspection"](#).

Is the inspection result normal?

- YES >> GO TO 9.
NO >> Replace VIAS control solenoid valve 2.

9.CHECK INTERMITTENT INCIDENT

Refer to [GI-40. "Intermittent Incident"](#).

>> INSPECTION END

< ECU DIAGNOSIS >

ECU DIAGNOSIS**ECM****Reference Value**

INFOID:000000003388285

VALUES ON THE DIAGNOSIS TOOL**Remarks:**

- Specification data are reference values.
- Specification data are output/input values which are detected or supplied by the ECM at the connector.
- * Specification data may not be directly related to their components signals/values/operations.

I.e. Adjust ignition timing with a timing light before monitoring IGN TIMING, because the monitor may show the specification data in spite of the ignition timing not being adjusted to the specification data. This IGN TIMING monitors the data calculated by the ECM according to the signals input from the camshaft position sensor and other ignition timing related sensors.

Monitor Item	Condition		Values/Status
ENG SPEED	Run engine and compare CONSULT-III value with the tachometer indication.		Almost the same speed as the tachometer indication.
MAS A/F SE-B1	See EC-127, "Description" .		
B/FUEL SCHDL	See EC-127, "Description" .		
A/F ALPHA-B1	See EC-127, "Description" .		
A/F ALPHA-B2	See EC-127, "Description" .		
COOLAN TEMP/S	• Engine: After warming up		More than 70°C (158°F)
A/F SEN1 (B1)	• Engine: After warming up	Maintaining engine speed at 2,000 rpm	Fluctuates around 2.2 V
A/F SEN1 (B2)	• Engine: After warming up	Maintaining engine speed at 2,000 rpm	Fluctuates around 2.2 V
HO2S2 (B1)	<ul style="list-style-type: none"> • Revving engine from idle to 3,000 rpm quickly after the following conditions are met. - Engine: After warming up - After keeping engine speed between 3,500 and 4,000 rpm for 1 minute and at idle for 1 minute under no load 		0 - 0.3 V ↔ Approx. 0.6 - 1.0 V
HO2S2 (B2)	<ul style="list-style-type: none"> • Revving engine from idle to 3,000 rpm quickly after the following conditions are met. - Engine: After warming up - After keeping engine speed between 3,500 and 4,000 rpm for 1 minute and at idle for 1 minute under no load 		0 - 0.3 V ↔ Approx. 0.6 - 1.0 V
HO2S2 MNTR (B1)	<ul style="list-style-type: none"> • Revving engine from idle to 3,000 rpm quickly after the following conditions are met. - Engine: After warming up - After keeping engine speed between 3,500 and 4,000 rpm for 1 minute and at idle for 1 minute under no load 		LEAN ↔ RICH
HO2S2 MNTR (B2)	<ul style="list-style-type: none"> • Revving engine from idle to 3,000 rpm quickly after the following conditions are met. - Engine: After warming up - After keeping engine speed between 3,500 and 4,000 rpm for 1 minute and at idle for 1 minute under no load 		LEAN ↔ RICH
VHCL SPEED SE	• Turn drive wheels and compare CONSULT-III value with the speedometer indication.		Almost the same speed as speedometer indication
BATTERY VOLT	• Ignition switch: ON (Engine stopped)		11 - 14 V
ACCEL SEN 1	• Ignition switch: ON (Engine stopped)	Accelerator pedal: Fully released	0.5 - 1.0 V
		Accelerator pedal: Fully depressed	4.2 - 4.8 V
ACCEL SEN 2*1	• Ignition switch: ON (Engine stopped)	Accelerator pedal: Fully released	0.5 - 1.0 V
		Accelerator pedal: Fully depressed	4.2 - 4.8 V

ECM

< ECU DIAGNOSIS >

[VQ35DE]

Monitor Item	Condition		Values/Status
TP SEN 1-B1	<ul style="list-style-type: none"> Ignition switch: ON (Engine stopped) Selector lever: D position 	Accelerator pedal: Fully released	More than 0.36 V
		Accelerator pedal: Fully depressed	Less than 4.75 V
TP SEN 2-B1*1	<ul style="list-style-type: none"> Ignition switch: ON (Engine stopped) Selector lever: D position 	Accelerator pedal: Fully released	More than 0.36 V
		Accelerator pedal: Fully depressed	Less than 4.75 V
FUEL T/TMP SE	<ul style="list-style-type: none"> Ignition switch: ON 		Indicates fuel tank temperature
INT/A TEMP SE	<ul style="list-style-type: none"> Ignition switch: ON 		Indicates intake air temperature
EVAP SYS PRES	<ul style="list-style-type: none"> Ignition switch: ON 		Approx. 1.8 - 4.8 V
FUEL LEVEL SE	<ul style="list-style-type: none"> Ignition switch: ON 		Depending on fuel level of fuel tank
START SIGNAL	<ul style="list-style-type: none"> Ignition switch: ON → START → ON 		OFF → ON → OFF
CLSD THL POS	<ul style="list-style-type: none"> Ignition switch: ON (Engine stopped) 	Accelerator pedal: Fully released	ON
		Accelerator pedal: Slightly depressed	OFF
AIR COND SIG	<ul style="list-style-type: none"> Engine: After warming up, idle the engine 	Air conditioner switch: OFF	OFF
		Air conditioner switch: ON (Compressor operates.)	ON
P/N POSI SW	<ul style="list-style-type: none"> Ignition switch: ON 	Selector lever: P or N position	ON
		Selector lever: Except above position	OFF
PW/ST SIGNAL	<ul style="list-style-type: none"> Engine: After warming up, idle the engine 	Steering wheel: Not being turned	OFF
		Steering wheel: Being turned	ON
LOAD SIGNAL	<ul style="list-style-type: none"> Ignition switch: ON 	Rear window defogger switch: ON and/or Lighting switch: 2nd position	ON
		Rear window defogger switch and lighting switch: OFF	OFF
IGNITION SW	<ul style="list-style-type: none"> Ignition switch: ON → OFF → ON 		ON → OFF → ON
HEATER FAN SW	<ul style="list-style-type: none"> Engine: After warming up, idle the engine 	Heater fan switch: ON	ON
		Heater fan switch: OFF	OFF
BRAKE SW	<ul style="list-style-type: none"> Ignition switch: ON 	Brake pedal: Fully released	OFF
		Brake pedal: Slightly depressed	ON
INJ PULSE-B1	<ul style="list-style-type: none"> Engine: After warming up Selector lever: P or N position Air conditioner switch: OFF No load 	Idle	2.0 - 3.0 msec
		2,000 rpm	1.9 - 2.9 msec
INJ PULSE-B2	<ul style="list-style-type: none"> Engine: After warming up Selector lever: P or N position Air conditioner switch: OFF No load 	Idle	2.0 - 3.0 msec
		2,000 rpm	1.9 - 2.9 msec
IGN TIMING	<ul style="list-style-type: none"> Engine: After warming up Selector lever: P or N position Air conditioner switch: OFF No load 	Idle	7 - 17°BTDC
		2,000 rpm	25 - 45°BTDC
CAL/LD VALUE	<ul style="list-style-type: none"> Engine: After warming up Selector lever: P or N position Air conditioner switch: OFF No load 	Idle	5 - 35%
		2,500 rpm	5 - 35%
MASS AIRFLOW	<ul style="list-style-type: none"> Engine: After warming up Selector lever: P or N position Air conditioner switch: OFF No load 	Idle	2.0 - 6.0 g-m/s
		2,500 rpm	7.0 - 20.0 g-m/s

A

EC

C

D

E

F

G

H

I

J

K

L

M

N

O

P

ECM

< ECU DIAGNOSIS >

[VQ35DE]

Monitor Item	Condition	Values/Status	
PURG VOL C/V	<ul style="list-style-type: none"> Engine: After warming up Selector lever: P or N position Air conditioner switch: OFF No load 	Idle (Accelerator pedal: Not depressed even slightly, after engine starting.)	0%
		2,000 rpm	—
INT/V TIM (B1)	<ul style="list-style-type: none"> Engine: After warming up Selector lever: P or N position Air conditioner switch: OFF No load 	Idle	-5 - 5°C
		2,000 rpm	Approx. 0 - 30°C
INT/V TIM (B2)	<ul style="list-style-type: none"> Engine: After warming up Selector lever: P or N position Air conditioner switch: OFF No load 	Idle	-5 - 5°C
		2,000 rpm	Approx. 0 - 30°C
INT/V SOL (B1)	<ul style="list-style-type: none"> Engine: After warming up Selector lever: P or N position Air conditioner switch: OFF No load 	Idle	0 - 2%
		2,000 rpm	Approx. 0 - 50%
INT/V SOL (B2)	<ul style="list-style-type: none"> Engine: After warming up Selector lever: P or N position Air conditioner switch: OFF No load 	Idle	0 - 2%
		2,000 rpm	Approx. 0 - 50%
VIAS S/V-1	<ul style="list-style-type: none"> Engine: After warming up Selector lever: P or N position Air conditioner switch: OFF No load 	When revving engine up to 5,000 rpm quickly	OFF → ON → OFF
VIAS S/V-2	<ul style="list-style-type: none"> Engine: After warming up Selector lever: P or N position Air conditioner switch: OFF No load 	When revving engine up to 5,000 rpm quickly	OFF → ON → OFF
AIR COND RLY	<ul style="list-style-type: none"> Engine: After warming up, idle the engine 	Air conditioner switch: OFF	OFF
		Air conditioner switch: ON (Compressor operates)	ON
ENGINE MOUNT	<ul style="list-style-type: none"> Engine: After warming up 	Below 950 rpm	IDLE
		Above 950 rpm	TRVL
FUEL PUMP RLY	<ul style="list-style-type: none"> For 1 second after turning ignition switch: ON Engine running or cranking 		ON
	<ul style="list-style-type: none"> Except above 		OFF
VENT CONT/V	<ul style="list-style-type: none"> Ignition switch: ON 		OFF
THRTL RELAY	<ul style="list-style-type: none"> Ignition switch: ON 		ON
COOLING FAN	<ul style="list-style-type: none"> Engine: After warming up, idle the engine Air conditioner switch: OFF 	Engine coolant temperature: 97°C (206°F) or less	OFF
		Engine coolant temperature: Between 98°C (208°F) and 99°C (210°F)	LOW
		Engine coolant temperature: Between 100°C (212°F) and 104°C (219°F)	MID
		Engine coolant temperature: 105°C (221°F) or more	HI
HO2S2 HTR (B1)	<ul style="list-style-type: none"> Engine speed: Below 3,600 rpm after the following conditions are met. <ul style="list-style-type: none"> Engine: After warming up Keeping the engine speed between 3,500 and 4,000 rpm for 1 minute and at idle for 1 minute under no load 		ON
	<ul style="list-style-type: none"> Engine speed: Above 3,600 rpm 		OFF

ECM

< ECU DIAGNOSIS >

[VQ35DE]

Monitor Item	Condition		Values/Status
HO2S2 HTR (B2)	<ul style="list-style-type: none"> Engine speed: Below 3,600 rpm after the following conditions are met. <ul style="list-style-type: none"> Engine: After warming up Keeping the engine speed between 3,500 and 4,000 rpm for 1 minute and at idle for 1 minute under no load 		ON
	<ul style="list-style-type: none"> Engine speed: Above 3,600 rpm 		OFF
I/P PULLY SPD	<ul style="list-style-type: none"> Vehicle speed: More than 20 km/h (12 MPH) 		Almost the same speed as the tachometer indication
VEHICLE SPEED	<ul style="list-style-type: none"> Turn drive wheels and compare CONSULT-III value with the speedometer indication. 		Almost the same speed as the speedometer indication
IDL A/V LEARN	<ul style="list-style-type: none"> Engine: Running 	Idle air volume learning has not been performed yet.	YET
		Idle air volume learning has already been performed successfully.	CMPLT
ENG OIL TEMP	<ul style="list-style-type: none"> Engine: After warming up 		More than 70°C (158°F)
TRVL AFTER MIL	<ul style="list-style-type: none"> Ignition switch: ON 	Vehicle has traveled after MIL has illuminated.	0 - 65,535 km (0 - 40,723 miles)
A/F S1 HTR (B1)	<ul style="list-style-type: none"> Engine: After warming up, idle the engine (More than 140 seconds after starting engine) 		4 - 100%
A/F S1 HTR (B2)	<ul style="list-style-type: none"> Engine: After warming up, idle the engine (More than 140 seconds after starting engine) 		4 - 100%
AC PRESS SEN	<ul style="list-style-type: none"> Engine: Idle Both A/C switch and blower fan switch: ON (Compressor operates) 		1.0 - 4.0 V
VHCL SPEED SE	<ul style="list-style-type: none"> Turn drive wheels and compare CONSULT-III value with the speedometer indication. 		Almost the same speed as the speedometer indication
SET VHCL SPD	<ul style="list-style-type: none"> Engine: Running 	ASCD: Operating	The preset vehicle speed is displayed
MAIN SW	<ul style="list-style-type: none"> Ignition switch: ON 	MAIN switch: Pressed	ON
		MAIN switch: Released	OFF
CANCEL SW	<ul style="list-style-type: none"> Ignition switch: ON 	CANCEL switch: Pressed	ON
		CANCEL switch: Released	OFF
RESUME/ACC SW	<ul style="list-style-type: none"> Ignition switch: ON 	RESUME/ACCELERATE switch: Pressed	ON
		RESUME/ACCELERATE switch: Released	OFF
SET SW	<ul style="list-style-type: none"> Ignition switch: ON 	SET/COAST switch: Pressed	ON
		SET/COAST switch: Released	OFF
BRAKE SW1 (ASCD brake switch)	<ul style="list-style-type: none"> Ignition switch: ON 	Brake pedal: Fully released	ON
		Brake pedal: Slightly depressed	OFF
BRAKE SW2 (Stop lamp switch)	<ul style="list-style-type: none"> Ignition switch: ON 	Brake pedal: Fully released	OFF
		Brake pedal: Slightly depressed	ON
VHCL SPD CUT	<ul style="list-style-type: none"> Ignition switch: ON 		NON
LO SPEED CUT	<ul style="list-style-type: none"> Ignition switch: ON 		NON
AT OD MONITOR	<ul style="list-style-type: none"> Ignition switch: ON 		OFF
AT OD CANCEL	<ul style="list-style-type: none"> Ignition switch: ON 		OFF
CRUISE LAMP	<ul style="list-style-type: none"> Ignition switch: ON 	MAIN switch: Pressed at the 1st time → at the 2nd time	ON → OFF
SET LAMP	<ul style="list-style-type: none"> MAIN switch: ON When vehicle speed is between 40 km/h (25 MPH) and 144 km/h (89 MPH) 	ASCD: Operating	ON
		ASCD: Not operating	OFF

A
EC
C
D
E
F
G
H
I
J
K
L
M
N
O
P

< ECU DIAGNOSIS >

Monitor Item	Condition	Values/Status
ALT DUTY	• Engine: Idle	0 - 80%
A/F ADJ-B1	• Engine: Running	-0.330 - 0.330
A/F ADJ-B2	• Engine: Running	-0.330 - 0.330
BAT CUR SEN	• Engine speed: Idle • Battery: Fully charged*2 • Selector lever: P or N position • Air conditioner switch: OFF • No load	Approx. 2,600 - 3,500 mV
ALT DUTY SIG	• Power generation voltage variable control: Operating	ON
	• Power generation voltage variable control: Not operating	OFF

*1: Accelerator pedal position sensor 2 signal and throttle position sensor 2 signal are converted by ECM internally. Thus, they differ from ECM terminals voltage signal.

*2: Before measuring the terminal voltage, confirm that the battery is fully charged. Refer to [PG-3, "How to Handle Battery"](#).

TERMINAL LAYOUT

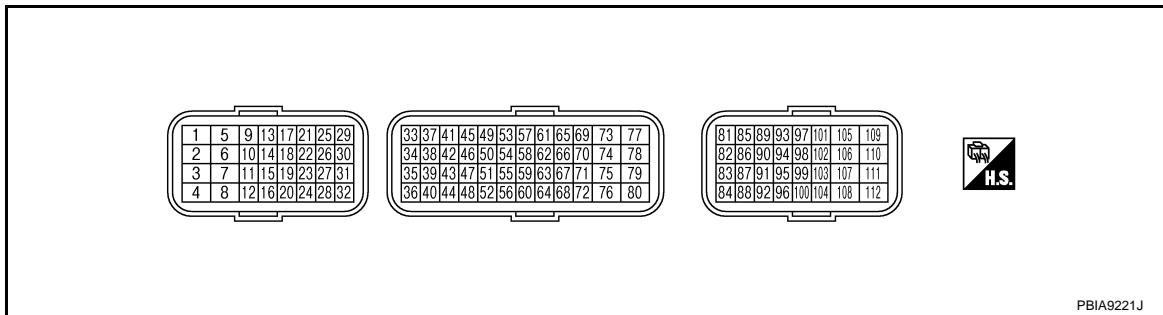

PHYSICAL VALUES

NOTE:

- ECM is located in the engine room left side near battery.
- Specification data are reference values.
- Pulse signal is measured by CONSULT-III.

Terminal No.		Description		Condition	Value (Approx.)
+	-	Signal name	Input/Output		
1 (P/B)	112 (B)	Fuel injector No. 6	Output	[Engine is running] • Warm-up condition • Idle speed NOTE: The pulse cycle changes depending on rpm at idle	BATTERY VOLTAGE (11 - 14 V)★ 50mSec/div 10V/div JMBIA0047GB
3 (L/W)		Fuel injector No. 5			
29 (LG/R)		Fuel injector No. 4			
30 (R/Y)		Fuel injector No. 3			
31 (R/W)		Fuel injector No. 2			
32 (R/B)	Fuel injector No. 1			[Engine is running] • Warm-up condition • Engine speed: 2,000 rpm	BATTERY VOLTAGE (11 - 14 V)★ 50mSec/div 10V/div JMBIA0048GB
2 (G/W)	112 (B)	Throttle control motor power supply	Input	[Ignition switch: ON]	BATTERY VOLTAGE (11 - 14 V)

ECM

< ECU DIAGNOSIS >

[VQ35DE]

Terminal No.		Description		Condition	Value (Approx.)
+	-	Signal name	Input/Output		
4 (BR/Y)	112 (B)	A/F sensor 1 heater (bank 1)	Output	[Engine is running] • Warm-up condition • Idle speed (More than 140 seconds after starting engine)	2.9 - 8.8 V★
5 (L)	112 (B)	Throttle control motor (Open)	Output	[Ignition switch: ON] • Engine stopped • Selector lever: D position • Accelerator pedal: Fully depressed	0 - 14 V★
				[Ignition switch: ON] • Engine stopped • Selector lever: D position • Accelerator pedal: Fully released	0 - 14 V★
6 (P)	112 (B)	Throttle control motor (Close)	Output	[Ignition switch: ON] • Engine stopped • Selector lever: D position • Accelerator pedal: Fully released	0 - 14 V★
8 (SB)	112 (B)	A/F sensor 1 heater (bank 2)	Output	[Engine is running] • Warm-up condition • Idle speed (More than 140 seconds after starting engine)	2.9 - 8.8 V★

A
EC
C
D
E
F
G
H
I
J
K
L
M
N
O
P

ECM

< ECU DIAGNOSIS >

[VQ35DE]

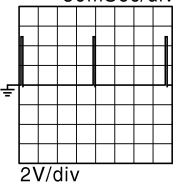
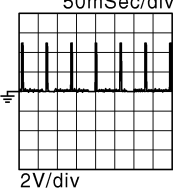
Terminal No.		Description		Condition	Value (Approx.)	
+	-	Signal name	Input/Output			
9 (L/B)	112 (B)	Ignition signal No. 3	Output	[Engine is running] • Warm-up condition • Idle speed NOTE: The pulse cycle changes depending on rpm at idle	0 - 0.2 V★	
10 (G/R)		Ignition signal No. 2			[Engine is running] • Warm-up condition • Engine speed: 2,000 rpm	
11 (Y/R)		Ignition signal No. 1				
18 (GR/R)		Ignition signal No. 6				
19 (P)		Ignition signal No. 5				
21 (W)	Ignition signal No. 4					
12 (B)	-	ECM ground	-	-	-	
13 (P/B)	112 (B)	Heated oxygen sensor 2 heater (bank 1)	Output	[Engine is running] • Engine speed: Below 3,600 rpm after the following conditions are met - Engine: after warming up - Keeping the engine speed between 3,500 and 4,000 rpm for 1 minute and at idle for 1 minute under no load	10 V★	
				[Ignition switch: ON] • Engine stopped [Engine is running] • Engine speed: Above 3,600 rpm	BATTERY VOLTAGE (11 - 14 V)	
14 (GR)	112 (B)	Fuel pump relay	Output	[Ignition switch: ON] • For 1 second after turning ignition switch ON	0 - 1.5 V	
				[Engine is running] [Ignition switch: ON] • More than 1 second after turning ignition switch ON	BATTERY VOLTAGE (11 - 14 V)	
15 (O)	112 (B)	Throttle control motor relay	Output	[Ignition switch: ON → OFF]	0 - 1.0 V → BATTERY VOLTAGE (11 - 14 V) → 0 V	
				[Ignition switch: ON]	0 - 1.0 V	
16 (B/Y)	-	ECM ground	-	-	-	

ECM

< ECU DIAGNOSIS >

[VQ35DE]

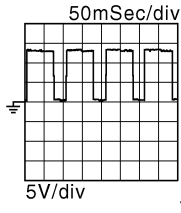
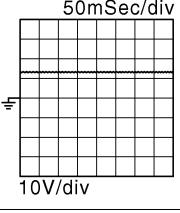
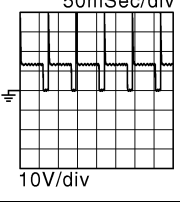
Terminal No.		Description		Condition	Value (Approx.)
+	-	Signal name	Input/Output		
17 (R)	112 (B)	Heated oxygen sensor 2 heater (bank 2)	Output	[Engine is running] <ul style="list-style-type: none"> • Engine speed: Below 3,600 rpm after the following conditions are met - Engine: after warming up - Keeping the engine speed between 3,500 and 4,000 rpm for 1 minute and at idle for 1 minute under no load 	10 V★ 
				[Ignition switch: ON] <ul style="list-style-type: none"> • Engine stopped [Engine is running] • Engine speed: Above 3,600 rpm 	BATTERY VOLTAGE (11 - 14 V)
24 (W/B)	112 (B)	ECM relay (Self shut-off)	Output	[Engine is running] <ul style="list-style-type: none"> [Ignition switch: OFF] • A few seconds after turning ignition switch OFF 	0 - 1.5 V
				[Ignition switch: OFF] <ul style="list-style-type: none"> • More than a few seconds after turning ignition switch OFF 	BATTERY VOLTAGE (11 - 14 V)
25 (P/L)	112 (B)	EVAP canister purge volume control solenoid valve	Output	[Engine is running] <ul style="list-style-type: none"> • Idle speed • Accelerator pedal: Not depressed even slightly, after engine starting 	BATTERY VOLTAGE (11 - 14 V)★ 
				[Engine is running] <ul style="list-style-type: none"> • Engine speed: approximately 2,000 rpm (More than 100 seconds after starting engine) 	BATTERY VOLTAGE (11 - 14 V)★ 
26 (GR/R) ^{*3} (GR/B) ^{*4}	112 (B)	VIAS control solenoid valve 2	Output	[Engine is running] <ul style="list-style-type: none"> • Warm-up condition • Idle speed 	BATTERY VOLTAGE (11 - 14 V)
				[Engine is running] <ul style="list-style-type: none"> • Warm-up condition • When revving engine up to 5,000 rpm quickly 	BATTERY VOLTAGE (11 - 14 V) ↓ 0 - 1.0 V ↓ BATTERY VOLTAGE (11 - 14 V)
27 (V)	112 (B)	VIAS control solenoid valve 1	Output	[Engine is running] <ul style="list-style-type: none"> • Warm-up condition • Idle speed 	BATTERY VOLTAGE (11 - 14 V)
				[Engine is running] <ul style="list-style-type: none"> • Warm-up condition • When revving engine up to 5,000 rpm quickly 	BATTERY VOLTAGE (11 - 14 V) ↓ 0 - 1.0 V ↓ BATTERY VOLTAGE (11 - 14 V)

A
EC
C
D
E
F
G
H
I
J
K
L
M
N
O
P

ECM

< ECU DIAGNOSIS >

[VQ35DE]

Terminal No.		Description		Condition	Value (Approx.)
+	—	Signal name	Input/ Output		
28 (BR/W)	112 (B)	Electronic controlled engine mount control solenoid valve	Output	[Engine is running] • Idle speed	0 - 1.0 V
				[Engine is running] • Engine speed: More than 950 rpm	BATTERY VOLTAGE (11 - 14 V)
33 (W)	112 (B)	Heated oxygen sensor 2 (bank 1)	Input	[Engine is running] • Revving engine from idle to 3,000 rpm quickly after the following conditions are met - Engine: after warming up - Keeping the engine speed between 3,500 and 4,000 rpm for 1 minute and at idle for 1 minute under no load	0 - 1.0 V
34 (W/L)	112 (B)	Heated oxygen sensor 2 (bank 2)	Input	[Engine is running] • Revving engine from idle to 3,000 rpm quickly after the following conditions are met - Engine: after warming up - Keeping the engine speed between 3,500 and 4,000 rpm for 1 minute and at idle for 1 minute under no load	0 - 1.0 V
35 (B)	—	Sensor ground (Heated oxygen sensor 2)	—	—	—
36 (B)	—	Sensor ground (Throttle position sensor)	—	—	—
37 (W)	112 (B)	Throttle position sensor 1	Input	[Ignition switch: ON] • Engine stopped • Selector lever: D position • Accelerator pedal: Fully released	More than 0.36 V
				[Ignition switch: ON] • Engine stopped • Selector lever: D position • Accelerator pedal: Fully depressed	Less than 4.75 V
38 (R)	112 (B)	Throttle position sensor 2	Input	[Ignition switch: ON] • Engine stopped • Selector lever: D position • Accelerator pedal: Fully released	Less than 4.75 V
				[Ignition switch: ON] • Engine stopped • Selector lever: D position • Accelerator pedal: Fully depressed	More than 0.36 V
39 (R)	40 (G)	Refrigerant pressure sensor	Input	[Engine is running] • Warm-up condition • Both A/C switch and blower fan motor switch: ON (Compressor operates)	1.0 - 4.0 V
40 (G)	—	Sensor ground (Refrigerant pressure sensor)	—	—	—

ECM

< ECU DIAGNOSIS >

[VQ35DE]

Terminal No.		Description		Condition	Value (Approx.)	
+	—	Signal name	Input/Output			
41 (O/B)	48 (B/P)	Power steering pressure sensor	Output	[Engine is running] • Steering wheel: Being turned	0.5 - 4.5 V	EC
				[Engine is running] • Steering wheel: Not being turned	0.4 - 0.8 V	C
42 (BR)	44 (G/B)	Battery current sensor	Input	[Engine is running] • Battery: Fully charged*2 • Idle speed	2.6 - 3.5 V	D
44 (G/B)	—	Sensor ground (Battery current sensor)	—	—	—	E
45 (P)	49 (L)	A/F sensor 1 (bank 1)	Input	[Ignition switch: ON]	2.2 V	F
46 (Y)	52 (B/R)	Engine coolant temperature sensor	Input	[Engine is running]	0 - 4.8 V Output voltage varies with engine coolant temperature.	G
47 (G)	36 (B)	Sensor power supply (Throttle position sensor)	—	[Ignition switch: ON]	5 V	H
48 (B/P)	—	Sensor ground (Power steering pressure sensor)	—	—	—	I
49 (L)	112 (B)	A/F sensor 1 (bank 1)	Input	[Engine is running] • Warm-up condition • Engine speed: 2,000 rpm	1.8 V Output voltage varies with air fuel ratio.	J
50 (L/Y)	56 (G/B)	Intake air temperature sensor	Input	[Engine is running]	0 - 4.8 V Output voltage varies with intake air temperature.	K
51 (R/Y)	44 (G/B)	Sensor power supply (Battery current sensor)	—	[Ignition switch: ON]	5 V	L
52 (B/R)	—	Sensor ground (Engine coolant temperature sensor/Engine oil temperature sensor)	—	—	—	M
53 (V)	57 (LG)	A/F sensor 1 (bank 2)	Input	[Ignition switch: ON]	2.2 V	N
54 (G)	52 (B/R)	Engine oil temperature sensor	Input	[Engine is running]	0 - 4.8 V Output voltage varies with engine oil temperature.	O
55 (SB)	48 (Y)	Sensor power supply (Power steering pressure sensor)	—	[Ignition switch: ON]	5 V	P
56 (G/B)	—	Sensor ground (Mass air flow sensor/Intake air temperature sensor)	—	—	—	P
57 (LG)	112 (B)	A/F sensor 1 (bank 2)	Input	[Engine is running] • Warm-up condition • Engine speed: 2,000 rpm	1.8 V Output voltage varies with air fuel ratio.	
				[Engine is running] • Warm-up condition • Idle speed	0.9 - 1.2 V	
58 (O)	56 (G/B)	Mass air flow sensor	Input	[Engine is running] • Warm-up condition • Idle speed	0.9 - 1.2 V	
				[Engine is running] • Warm-up condition • Engine speed: 2,500 rpm	1.6 - 1.9 V	

ECM

< ECU DIAGNOSIS >

[VQ35DE]

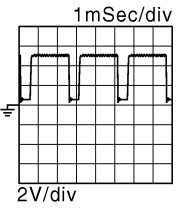
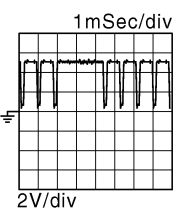
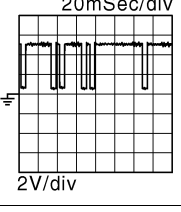
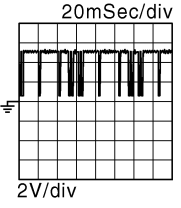
Terminal No.		Description		Condition	Value (Approx.)
+	—	Signal name	Input/Output		
59 (G/W)	64 (B/R)	Sensor power supply [Camshaft position sensor (PHASE) (bank 1)]	—	[Ignition switch: ON]	5 V
60 (Y/B)	—	Sensor ground [Crankshaft position sensor (POS)]	—	—	—
61 (B)	67 (—)	Knock sensor (bank 1)	Input	[Engine is running] • Idle speed	2.5 V*1
62 (W)	67 (—)	Knock sensor (bank 2)	Input	[Engine is running] • Idle speed	2.5 V*1
63 (R/W)	68 (Y/G)	Sensor power supply [Camshaft position sensor (PHASE) (bank 2)]	—	[Ignition switch: ON]	5 V
64 (B/R)	—	Sensor ground [Camshaft position sensor (PHASE) (bank 1)]	—	—	—
65 (W/B)	60 (Y/B)	Crankshaft position sensor (POS)	Input	[Engine is running] • Warm-up condition • Idle speed NOTE: The pulse cycle changes depending on rpm at idle	4.0 - 5.0 V★  2V/div JMBIA0041GB
				[Engine is running] • Engine speed: 2,000 rpm	4.0 - 5.0 V★  2V/div JMBIA0042GB
67 (—)	—	Sensor ground (Knock sensor)	—	—	—
68 (Y/G)	—	Sensor ground [Camshaft position sensor (PHASE) (bank 2)]	—	—	—
69 (BR/W)	68 (Y/G)	Camshaft position sensor (PHASE) (bank 2)	Input	[Engine is running] • Warm-up condition • Idle speed NOTE: The pulse cycle changes depending on rpm at idle	3.0 - 5.0 V★  2V/div JMBIA0045GB
				[Engine is running] • Engine speed is 2,000 rpm	3.0 - 5.0 V★  2V/div JMBIA0046GB

ECM

< ECU DIAGNOSIS >

[VQ35DE]

Terminal No.		Description		Condition	Value (Approx.)
+	-	Signal name	Input/Output		
70 (W/R)	64 (B/R)	Camshaft position sensor (PHASE) (bank 1)	Input	[Engine is running] • Warm-up condition • Idle speed NOTE: The pulse cycle changes depending on rpm at idle	3.0 - 5.0 V★ JMBIA0045GB
				[Engine is running] • Engine speed is 2,000 rpm	3.0 - 5.0 V★ JMBIA0046GB
72 (BR/W)	40 (G)	Sensor power supply (Refrigerant pressure sensor)	—	[Ignition switch: ON]	5 V
75 (Y)	112 (B)	Intake valve timing control solenoid valve (bank 2)	Output	[Engine is running] • Warm-up condition • Idle speed	BATTERY VOLTAGE (11 - 14 V)
				[Engine is running] • Warm-up condition • Engine speed: 2,000 rpm	7 - 12 V★ JMBIA0038GB
76 (R/G)	60 (Y/B)	Sensor power supply [Crankshaft position sensor (POS)]	—	[Ignition switch: ON]	5 V
77 (W/L)	112 (B)	Power supply for ECM (Back-up)	Input	[Ignition switch: OFF]	BATTERY VOLTAGE (11 - 14 V)
78 (R/L)	112 (B)	Intake valve timing control solenoid valve (bank 1)	Output	[Engine is running] • Warm-up condition • Idle speed	BATTERY VOLTAGE (11 - 14 V)
				[Engine is running] • Warm-up condition • Engine speed: 2,000 rpm	7 - 12 V★ JMBIA0038GB
81 (W)	84 (B)	Accelerator pedal position sensor 1	Input	[Ignition switch: ON] • Engine stopped • Accelerator pedal: Fully released	0.5 - 1.0 V
				[Ignition switch: ON] • Engine stopped • Accelerator pedal: Fully depressed	4.2 - 4.8 V

A
EC
C
D
E
F
G
H
I
J
K
L
M
N
O
P

ECM

< ECU DIAGNOSIS >

[VQ35DE]

Terminal No.		Description		Condition	Value (Approx.)
+	—	Signal name	Input/ Output		
82 (O)	100 (G)	Accelerator pedal position sensor 2	Input	[Ignition switch: ON] • Engine stopped • Accelerator pedal: Fully released	0.25 - 0.50 V
				[Ignition switch: ON] • Engine stopped • Accelerator pedal: Fully depressed	2.0 - 2.5 V
83 (BR)	84 (B)	Sensor power supply (Accelerator pedal position sensor 1)	—	[Ignition switch: ON]	5 V
84 (B)	—	Sensor ground (Accelerator pedal position sensor 1)	—	—	—
85 (Y)	92 (BR)	ASCD steering switch	Input	[Ignition switch: ON] • ASCD steering switch: OFF	4 V
				[Ignition switch: ON] • MAIN switch: Pressed	0 V
				[Ignition switch: ON] • CANCEL switch: Pressed	1 V
				[Ignition switch: ON] • RESUME/ACCELERATE switch: Pressed	3 V
				[Ignition switch: ON] • SET/COAST switch: Pressed	2 V
86 (SB)	96 (GR)	EVAP control system pressure sensor	Input	[Ignition switch: ON]	1.8 - 4.8 V
87 (GR)	100 (G)	Sensor power supply (Accelerator pedal position sensor 2)	—	[Ignition switch: ON]	5 V
88 (O)	—	Data link connector	Input/ Output	—	—
91 (L)	96 (GR)	Sensor power supply (EVAP control system pressure sensor)	—	[Ignition switch: ON]	5 V
92 (BR)	—	Sensor ground (ASCD steering switch)	—	—	—
93 (BR)	112 (B)	Ignition switch	Input	[Ignition switch: OFF]	0 V
				[Ignition switch: ON]	BATTERY VOLTAGE (11 - 14 V)

ECM

< ECU DIAGNOSIS >

[VQ35DE]

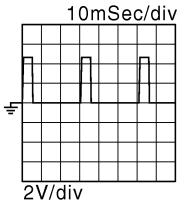
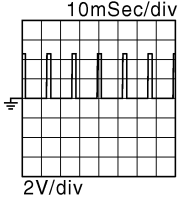
Terminal No.		Description		Condition	Value (Approx.)
+	—	Signal name	Input/Output		
94 (GR)	112 (B)	Engine speed output signal	Output	[Engine is running] • Warm-up condition • Idle speed NOTE: The pulse cycle changes depending on rpm at idle	1 V★ 
				[Engine is running] • Engine speed: 2,000 rpm	1 V★ 
95 (Y)	104 (SB)	Fuel tank temperature sensor	Input	[Engine is running]	0 - 4.8 V Output voltage varies with fuel tank temperature.
96 (GR)	—	Sensor ground (EVAP control system pressure sensor)	—	—	—
97 (P)	—	CAN communication line	Input/Output	—	—
98 (L)	—	CAN communication line	Input/Output	—	—
100 (G)	—	Sensor ground (Accelerator pedal position sensor 2)	—	—	—
102 (R)	112 (B)	PNP signal	Input	[Ignition switch: ON] • Selector lever: P or N position	BATTERY VOLTAGE (11 - 14 V)
				[Ignition switch: ON] • Selector lever: Except above position	0 V
104 (SB)	—	Sensor ground (Fuel tank temperature sensor)	—	—	—
105 (V)	112 (B)	Power supply for ECM	Input	[Ignition switch: ON]	BATTERY VOLTAGE (11 - 14 V)
106 (SB)	112 (B)	Stop lamp switch	Input	[Ignition switch: OFF] • Brake pedal: Fully released	0 V
				[Ignition switch: OFF] • Brake pedal: Slightly depressed	BATTERY VOLTAGE (11 - 14 V)
107 (B) 108 (B)	—	ECM ground	—	—	—
109 (W)	112 (B)	EVAP canister vent control valve	Output	[Ignition switch: ON]	BATTERY VOLTAGE (11 - 14 V)

A
EC
C
D
E
F
G
H
I
J
K
L
M
N
O
P

ECM

< ECU DIAGNOSIS >

[VQ35DE]

Terminal No.		Description		Condition	Value (Approx.)
+	—	Signal name	Input/ Output		
110 (G)	112 (B)	ASCD brake switch	Input	[Ignition switch: ON] • Brake pedal: Slightly depressed	0 V
				[Ignition switch: ON] • Brake pedal: Fully released	BATTERY VOLTAGE (11 - 14 V)
111 (B) 112 (B)	—	ECM ground	—	—	—

★: Average voltage for pulse signal (Actual pulse signal can be confirmed by oscilloscope.)

*1: This may vary depending on internal resistance of the tester.

*2: Before measuring the terminal voltage, confirm that the battery is fully charged. Refer to [PG-3, "How to Handle Battery"](#).

*3: Up to VIN JN8AZ18U*9W100000, JN8AZ18W*9W200000, JN8AZ18U*9W710000, JN8AZ18W*9W810000.

*4: From VIN JN8AZ18U*9W100001, JN8AZ18W*9W200001, JN8AZ18U*9W710001, JN8AZ18W*9W810001.

Wiring Diagram—ENGINE CONTROL SYSTEM—

INFOID:000000003388286

NOTE:

- Type A Up to VIN: JN8AZ18U*9W100000, JN8AZ18W*9W200000 (EXCEPT FOR MEXICO), JN8AZ18U*9W710000, JN8AZ18W*9W810000 (FOR MEXICO)
- Type B From VIN: JN8AZ18U*9W100001, JN8AZ18W*9W200001 (EXCEPT FOR MEXICO), JN8AZ18U*9W710001, JN8AZ18W*9W810001 (FOR MEXICO)

Up to VIN: JN8AZ18U*9W100000, JN8AZ18W*9W200000 (EXCEPT FOR MEXICO),

JN8AZ18U*9W710000, JN8AZ18W*9W810000 (FOR MEXICO)

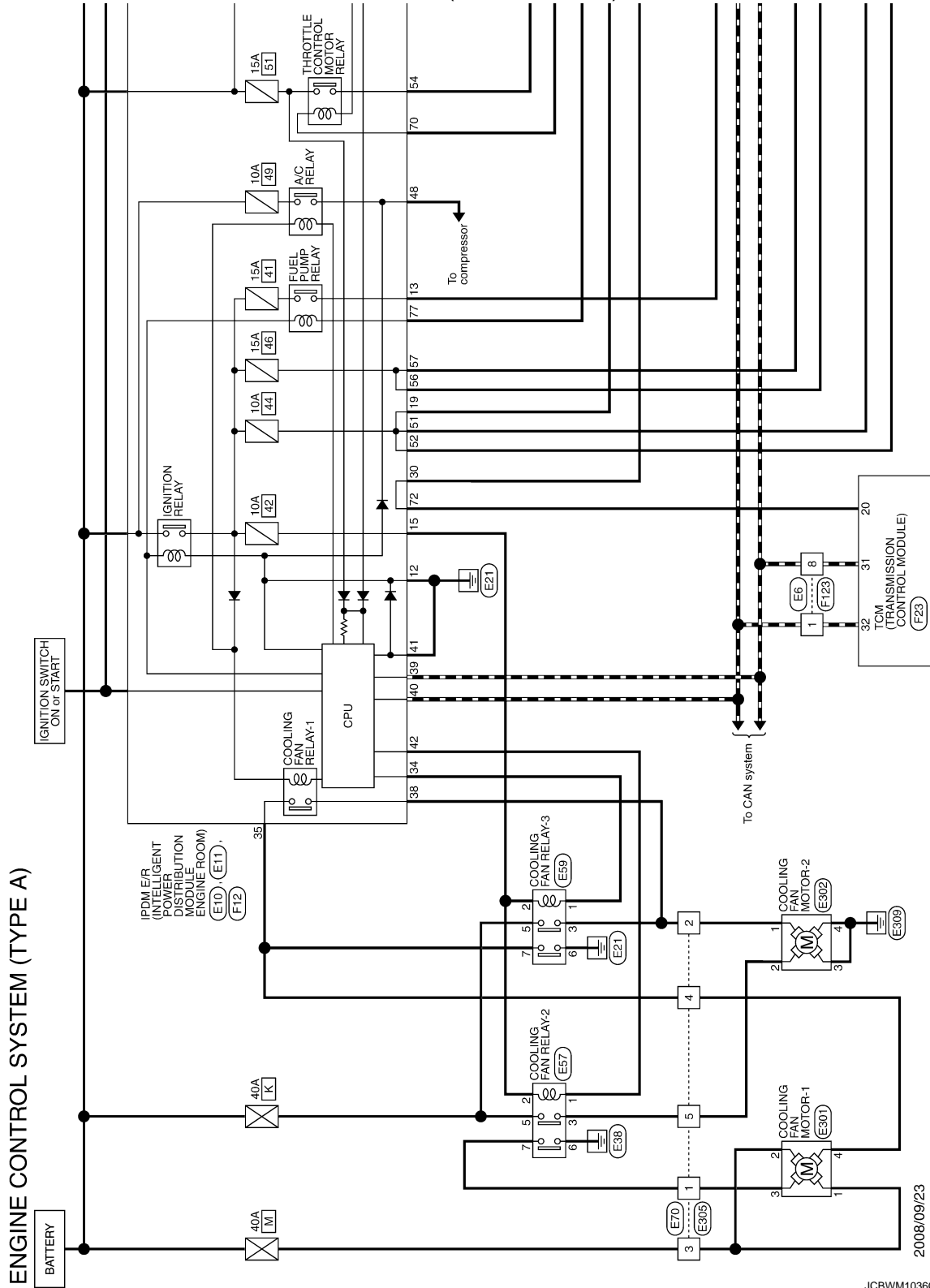

ENGINE CONTROL SYSTEM (TYPE A)

2008/09/23

JCBWM1036GF

A
EC
 C
 D
 E
 F
 G
 H
 I
 J
 K
 L
 M
 N
 O
 P

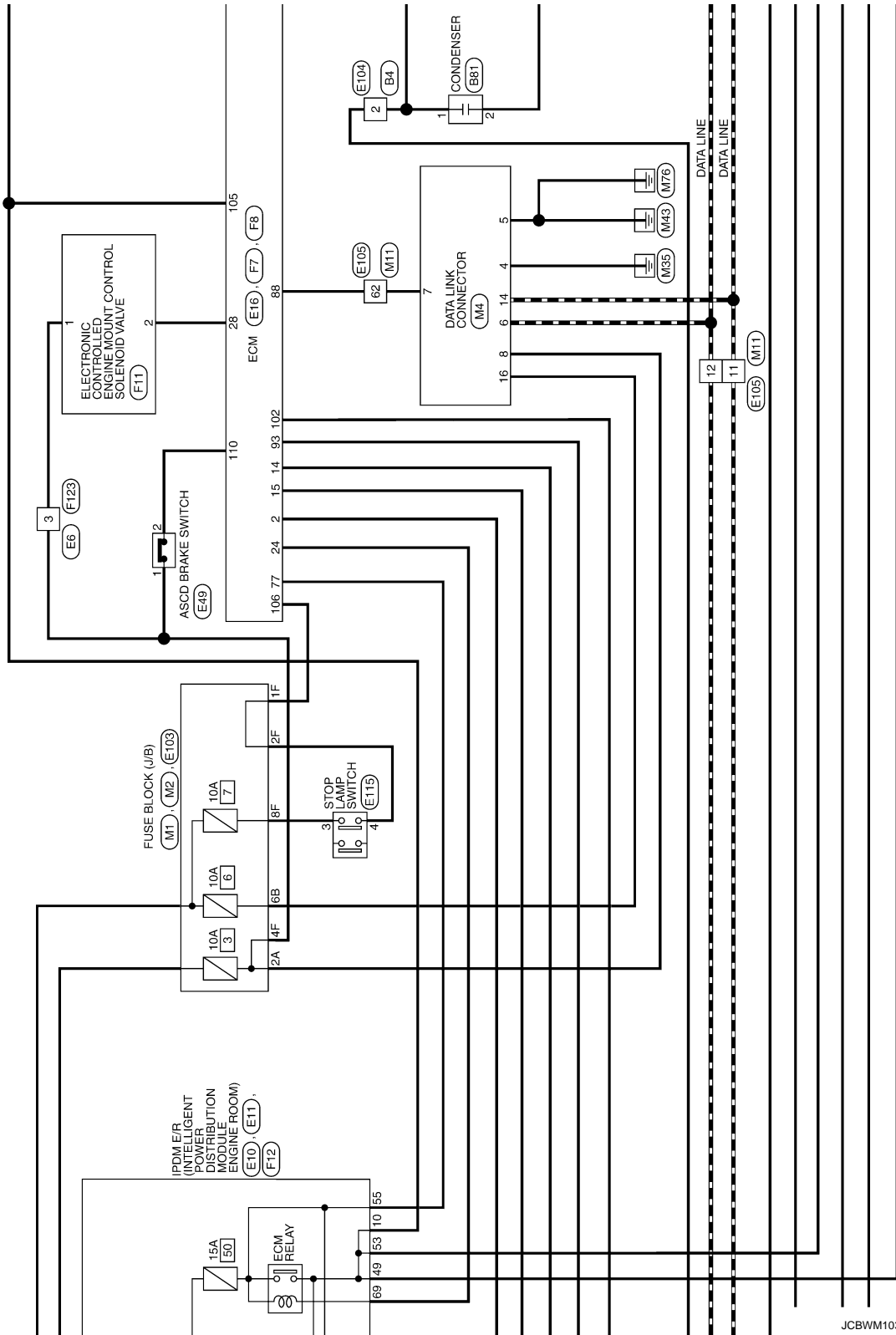

JCBWM1037Gf

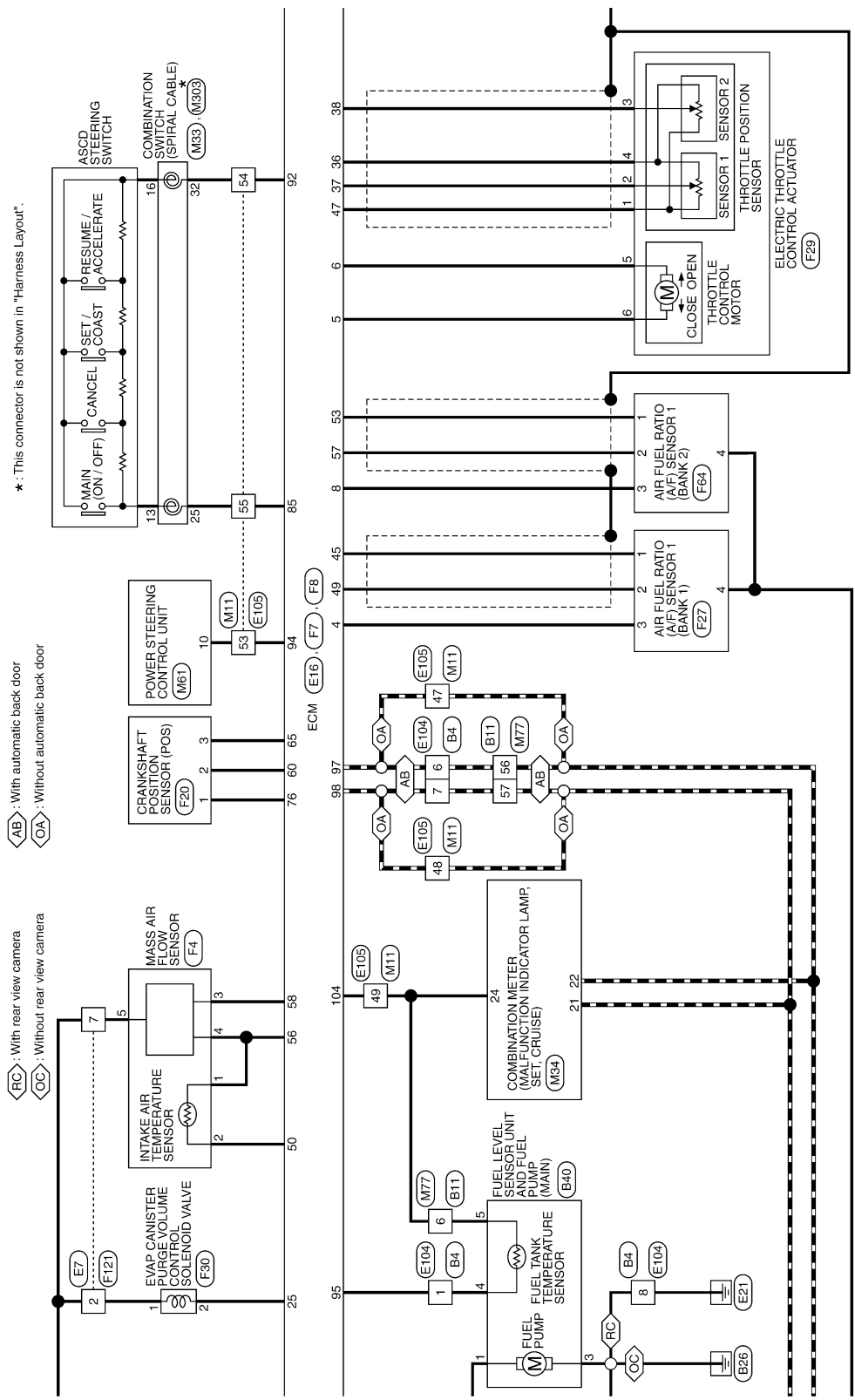

JCBWMM10386I



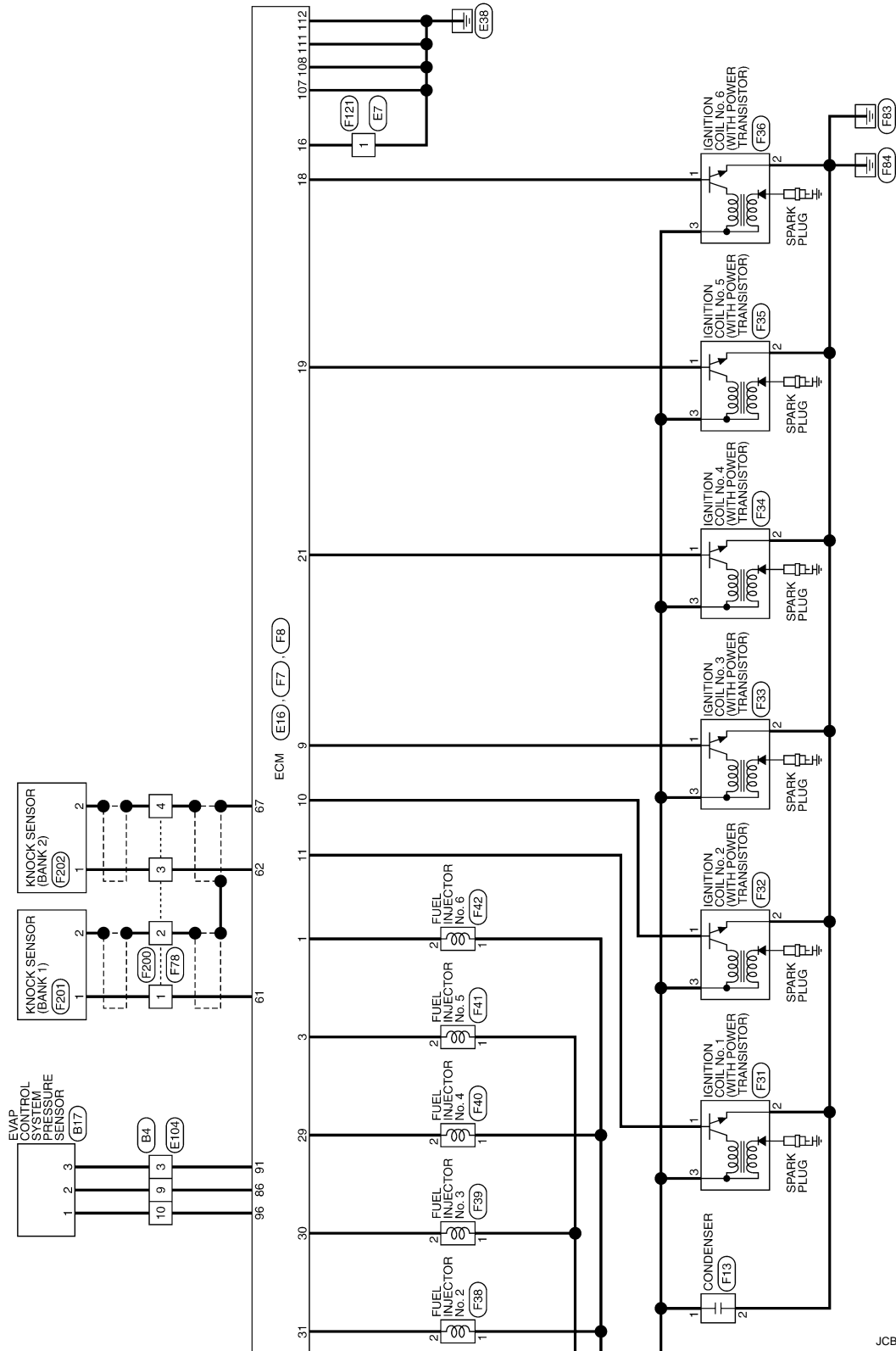











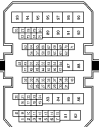

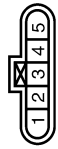

A
EC
 C
 D
 E
 F
 G
 H
 I
 J
 K
 L
 M
 N
 O
 P



JCBWM1040G1

A
EC
C
D
E
F
G
H
I
J
K
L
M
N
O
P

ENGINE CONTROL SYSTEM (TYPE A)

Connector No. B4	WIRE TO WIRE	NS16MW-CS		
Terminal No.	Color of Wire	Signal Name [Specification]		
1	SB	-		
2	W	-		
3	W	-		
6	P	-		
7	L	-		
8	B	-		
9	LG	-		
10	V	-		
11	L	-		
12	BR	-		
Connector No. B17	EVAP CONTROL SYSTEM PRESSURE SENSOR	E03FGY-RS		
Terminal No.	Color of Wire	Signal Name [Specification]		
1	V	-		
2	LG	-		
3	W	-		
Connector No. B11	WIRE TO WIRE	T18BMV-CS19		
Terminal No.	Color of Wire	Signal Name [Specification]		
6	P	-		
56	P	-		
57	L	-		
Connector No. B40	FUEL LEVEL SENSOR UNIT AND FUEL PUMP	E05FGY-RS		
Terminal No.	Color of Wire	Signal Name [Specification]		
1	W	-		
3	B	-		
4	SB	-		
5	P	-		
Connector No. B17	EVAP CONTROL SYSTEM PRESSURE SENSOR	E03FGY-RS		
Terminal No.	Color of Wire	Signal Name [Specification]		
1	L	-		
3	Y	-		
5	GR	-		
8	P	-		
11	G	-		
13	SB	-		
Connector No. E7	WIRE TO WIRE	NS10MW-CS		
Terminal No.	Color of Wire	Signal Name [Specification]		
1	B	-		
2	L	-		
5	R	-		
6	B	-		
7	O	-		
Connector No. E6	WIRE TO WIRE	TK16MGY-IV		
Terminal No.	Color of Wire	Signal Name [Specification]		
1	L	-		
3	Y	-		
5	GR	-		
8	P	-		
11	G	-		
13	SB	-		
Connector No. B81	CONDENSER	M02FW-LC		
Terminal No.	Color of Wire	Signal Name [Specification]		
1	W	-		
2	B	-		
Connector No. B85	EVAP CANISTER VENT CONTROL VALVE	E02FE-RS		
Terminal No.	Color of Wire	Signal Name [Specification]		
1	L	-		
2	BR	-		

ENGINE CONTROL SYSTEM (TYPE A)

Connector No.	E10
Connector Name	IPDM E/R (INTELLIGENT POWER DISTRIBUTION MODULE ENGINE ROOM)
Connector Type	TH20FW-CS12-M4-TV



Terminal No.	Color of Wire	Signal Name [Specification]
10	BR	-
12	B	-
13	SB	-
15	W	-
18	Y	-
22	SB	-
23	GR	-
24	G	-
30	BR	-
34	O	-
35	P	-

Connector No.	E16
Connector Name	ECM
Connector Type	RH24FB-RZ8-L-LH

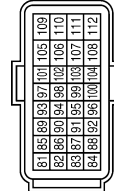

Terminal No.	Color of Wire	Signal Name [Specification]
81	W	APSI
82	O	APSZ
83	BR	AVCC1-APSI
84	B	GND1-APSI
85	Y	ASCDSW
86	SB	FTPRES
87	GR	AVCC2-APSZ
88	O	KLINE
91	L	AVCC2-FTPRES
92	BR	GND1-ASCDSW
93	BR	IGN SW

38	GR	-
----	----	---

Connector No.	E11
Connector Name	IPDM E/R (INTELLIGENT POWER DISTRIBUTION MODULE ENGINE ROOM)
Connector Type	TH20FW-NH



Terminal No.	Color of Wire	Signal Name [Specification]
39	P	-
40	L	-
41	B	-
42	SB	-

Connector No.	E49
Connector Name	ASC2 BRAKE SWITCH
Connector Type	MD2FER-LC



Terminal No.	Color of Wire	Signal Name [Specification]
1	R	-
2	G	-

Connector No.	E57
Connector Name	COOLING FAN RELAY-2
Connector Type	MD2FER-R-LC



Terminal No.	Color of Wire	Signal Name [Specification]
1	SB	-
2	G	-
3	L	-
5	Y	-
6	B	-
7	R	-

JCBWM1042G1

A
EC
C
D
E
F
G
H
I
J
K
L
M
N
O
P

ENGINE CONTROL SYSTEM (TYPE A)

Connector No.	E104
Connector Name	WIRE TO WIRE
Connector Type	NS3.6FW-CS



Terminal No.	Color of Wire	Signal Name [Specification]
1	Y	-
2	SB	-
3	L	-
6	P	-
7	L	-
8	B/W	-
9	SB	-
10	GR	-
11	R	-
12	W	-

Connector No.	E103
Connector Name	FUSE BLOCK (U/B)
Connector Type	NS3.6FW-CS



Terminal No.	Color of Wire	Signal Name [Specification]
1F	L	-
2F	LG	-
4F	BR	-
8F	R	-

Connector No.	E10
Connector Name	WIRE TO WIRE
Connector Type	M06AW-LC



Terminal No.	Color of Wire	Signal Name [Specification]
1	R	-
2	GR	-
3	BR	-
4	P	-
5	L	-

Connector No.	E59
Connector Name	COOLING FAN RELAY-3
Connector Type	M06FBR-R-LC



Terminal No.	Color of Wire	Signal Name [Specification]
1	O	-
2	Y	-
3	GR	-
5	Y	-
6	B	-
7	P	-

Connector No.	E300
Connector Name	REFRIGERANT PRESSURE SENSOR
Connector Type	RK03FB



Terminal No.	Color of Wire	Signal Name [Specification]
1	P	-
2	B	-
3	L	-

Connector No.	E115
Connector Name	STOP LAMP SWITCH (TYPE A)
Connector Type	M04FW-LC



Terminal No.	Color of Wire	Signal Name [Specification]
3	R	-
4	LG	-

Connector No.	E110
Connector Name	ACCELERATOR PEDAL POSITION SENSOR
Connector Type	RH06FB

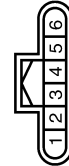

Terminal No.	Color of Wire	Signal Name [Specification]
1	G	-
2	B	-
3	W	-
4	BR	-
5	GR	-
6	O	-

Connector No.	E105
Connector Name	WIRE TO WIRE
Connector Type	TH70MW-CS10-M3



Terminal No.	Color of Wire	Signal Name [Specification]
11	P	-
12	L	-
47	P	-
48	L	-
49	SB	-
53	GR	-
54	BR	-
55	Y	-
62	O	-

JCBWM1043GI

ENGINE CONTROL SYSTEM (TYPE A)

Connector No.	E001
Connector Name	COOLING FAN MOTOR-1
Connector Type	RS04FGY-PR



Terminal No.	Color of Wire	Signal Name [Specification]
1	L	-
2	L	-
3	R	-
4	G	-

Connector No.	E002
Connector Name	COOLING FAN MOTOR-2
Connector Type	RS04FGY-PR



Terminal No.	Color of Wire	Signal Name [Specification]
1	BR	-
2	L	-
3	B	-
4	B	-

Connector No.	E305
Connector Name	WIRE TO WIRE
Connector Type	M06FFV-LC



Terminal No.	Color of Wire	Signal Name [Specification]
1	R	-
2	BR	-
3	L	-
4	G	-
5	L	-

Connector No.	E348
Connector Name	IPDM E/R (INTELLIGENT POWER DISTRIBUTION MODULE ENGINE ROOM)
Connector Type	TH18FV-NH



Terminal No.	Color of Wire	Signal Name [Specification]
101	L	-
102	B	-
103	P	-

Connector No.	F4
Connector Name	MASS AIR FLOW SENSOR
Connector Type	RH06FB



Terminal No.	Color of Wire	Signal Name [Specification]
1	G/B	-
2	L/Y	-
3	O	-
4	G/B	-
5	R/G	-

Connector No.	F7
Connector Name	ECM
Connector Type	RH24FGY-RZ8-R-LH



Terminal No.	Color of Wire	Signal Name [Specification]
1	P/B	INJ#6
2	G/W	VMOT-B1
3	L/W	INJ#5
4	BR/Y	AFH1
5	L	MOTOR1-B1
6	P	MOTOR2-B1
8	SB	AFH2
9	L/B	IGN#3
10	G/R	IGN#2
11	Y/R	IGN#1
12	B	GND

13	P/B	O2HR1
14	GR	FPR
15	O	MOTRLY-B1
16	B/Y	GND
17	R	O2HR2
18	GR/R	IGN#6
19	P	IGN#5
21	W	IGN#4
24	W/B	SSOFF
25	P/L	EVAP
26	GR/R	MASS2 [Type A]
27	V	VAST1
28	BR/W	EMMVV
29	LG/R	INJ#4
30	R/Y	INJ#3
31	R/W	INJ#2
32	R/B	INJ#1

A
EC
C
D
E
F
G
H
I
J
K
L
M
N
O
P

ENGINE CONTROL SYSTEM (TYPE A)

Connector No.	F8
Connector Name	ECM
Connector Type	RH40FB-R28-L-LH

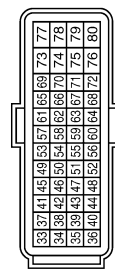

Terminal No.	Color of Wire	Signal Name [Specification]
33	W	O2SR1
34	W/L	O2SR2
35	B	GND-O2SR1/O2SR2
36	B	GND-TPS-B1
37	W	TPS1-B1
38	R	TPS2-B1
39	R	PPRES
40	G	GND-PPRES
41	O/B	PSPRES
42	BR	CURSEN
44	G/B	GND-CURSEN/INTP

Connector No.	F12
Connector Name	IPDM E/R (INTELLIGENT POWER DISTRIBUTION MODULE ENGINE ROOM)
Connector Type	TH20FW-CS12-M4

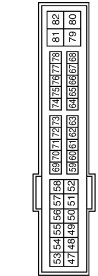

Terminal No.	Color of Wire	Signal Name [Specification]
48	W	-
49	R/B	-
51	LG	-
52	Y/G	-
53	R/W	-
54	G/W	-
55	W/L	-
56	R/Y	-
57	O	-
69	W/B	-
70	O	-

45	P	AF-1
46	Y	TW
47	G	AVCCI-TPS-B1
48	B/P	GND-PPRES
49	L	AF-1
50	L/Y	TAI
51	R/Y	AVCCI-CURSEN/INTP
52	B/R	GND-TW/TOT
53	V	AF-2
54	G	TOI
55	SB	AVCCI-PSPRES
56	G/B	OA-GND-A-TAI
57	LG	AF-2
58	O	OA1+
59	G/W	AVCCI-PHASE1/EP1
60	Y/B	GND-POS
61	B	KNK1
62	W	KNK2
63	R/W	AVCCI-PHASE2/EP2
64	B/B	GND-PHASE1/EP1
65	W/B	POS
67	SHIELD	GND-KNK1/KNK2
68	Y/G	GND-PHASE2/EP2
69	BR/W	PHASE#2
70	W/R	PHASE#1

72	R/B	-
77	GR	-

72	BR/W	AVCCZ-PDPRES
75	Y	CVTCH#2
76	R/G	AVCCZ-POS
77	W/L	BATT
78	R/L	CVTCH1



Connector No.	F11
Connector Name	ELECTRONIC CONTROLLED ENGINE MOUNT CONTROL SOLENOID VALVE
Connector Type	EQ2FBR-RS

Terminal No.	Color of Wire	Signal Name [Specification]
1	G/R	-
2	BR/W	-

Connector No.	F13
Connector Name	CONDENSER
Connector Type	M02FW-GY-LC



Connector No.	F20
Connector Name	CRANKSHAFT POSITION SENSOR (POS)
Connector Type	RH03FB



Terminal No.	Color of Wire	Signal Name [Specification]
1	R/G	-
2	Y/B	-
3	W/B	-

Terminal No.	Color of Wire	Signal Name [Specification]
1	R/B	-
2	B	-

ENGINE CONTROL SYSTEM (TYPE A)

Connector No.	F29
Connector Name	ELECTRIC THROTTLE CONTROL ACTUATOR
Connector Type	RH03FB

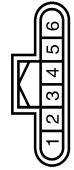

Terminal No.	Color of Wire	Signal Name [Specification]
1	G	INPUT
2	W	OUTPUT1
3	R	OUTPUT2
4	B	GND
5	P	MOTOR(CLOSE)
6	L	MOTOR(OPEN)

Connector No.	F27
Connector Name	AIR FUEL RATIO (A/F) SENSOR 1 (BANK 1)
Connector Type	AF204FB



Terminal No.	Color of Wire	Signal Name [Specification]
1	P	-
2	L	-
3	BR/Y	-
4	O	-

Connector No.	F26
Connector Name	CAMSHAFT POSITION SENSOR (PHASE) (BANK 1)
Connector Type	RH03FB



Terminal No.	Color of Wire	Signal Name [Specification]
1	G/W	-
2	B/R	-
3	W/R	-

Connector No.	F23
Connector Name	TCM (TRANSMISSION CONTROL MODULE)
Connector Type	RH40FB-R28-L-RH

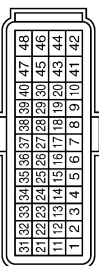

Terminal No.	Color of Wire	Signal Name [Specification]
20	R/B	STARTER RELAY
31	P	CAN-L
32	L	CAN-H

Connector No.	F33
Connector Name	IGNITION COIL No. 3 (WITH POWER TRANSISTOR)
Connector Type	EO3FGY-RS



Terminal No.	Color of Wire	Signal Name [Specification]
1	L/B	-
2	B	-
3	R/B	-

Connector No.	F32
Connector Name	IGNITION COIL No. 2 (WITH POWER TRANSISTOR)
Connector Type	EO3FGY-RS



Terminal No.	Color of Wire	Signal Name [Specification]
1	G/R	-
2	B	-
3	R/B	-

Connector No.	F31
Connector Name	IGNITION COIL No. 1 (WITH POWER TRANSISTOR)
Connector Type	EO3FGY-RS



Terminal No.	Color of Wire	Signal Name [Specification]
1	Y/R	-
2	B	-
3	R/B	-

Connector No.	F30
Connector Name	EVAP CANISTER PURGE VOLUME CONTROL SOLENOID VALVE
Connector Type	EO2FL-RS-LGY



















Terminal No.	Color of Wire	Signal Name [Specification]
1	R/Y	-
2	P/L	-

JCBWM1046G1

A
EC
C
D
E
F
G
H
I
J
K
L
M
N
O
P

ENGINE CONTROL SYSTEM (TYPE A)

<table border="1"> <tr> <td>Connector No.</td> <td>F34</td> </tr> <tr> <td>Connector Name</td> <td>IGNITION COIL No. 4 (WITH POWER TRANSISTOR)</td> </tr> <tr> <td>Connector Type</td> <td>E03FGY-RS</td> </tr> </table>   <table border="1"> <tr> <td>Terminal No.</td> <td>Color of Wire</td> <td>Signal Name [Specification]</td> </tr> <tr> <td>1</td> <td>W</td> <td>-</td> </tr> <tr> <td>2</td> <td>B</td> <td>-</td> </tr> <tr> <td>3</td> <td>R/B</td> <td>-</td> </tr> </table>	Connector No.	F34	Connector Name	IGNITION COIL No. 4 (WITH POWER TRANSISTOR)	Connector Type	E03FGY-RS	Terminal No.	Color of Wire	Signal Name [Specification]	1	W	-	2	B	-	3	R/B	-	<table border="1"> <tr> <td>Connector No.</td> <td>F35</td> </tr> <tr> <td>Connector Name</td> <td>IGNITION COIL No. 5 (WITH POWER TRANSISTOR)</td> </tr> <tr> <td>Connector Type</td> <td>E03FGY-RS</td> </tr> </table>   <table border="1"> <tr> <td>Terminal No.</td> <td>Color of Wire</td> <td>Signal Name [Specification]</td> </tr> <tr> <td>1</td> <td>P</td> <td>-</td> </tr> <tr> <td>2</td> <td>B</td> <td>-</td> </tr> <tr> <td>3</td> <td>R/B</td> <td>-</td> </tr> </table>	Connector No.	F35	Connector Name	IGNITION COIL No. 5 (WITH POWER TRANSISTOR)	Connector Type	E03FGY-RS	Terminal No.	Color of Wire	Signal Name [Specification]	1	P	-	2	B	-	3	R/B	-	<table border="1"> <tr> <td>Connector No.</td> <td>F36</td> </tr> <tr> <td>Connector Name</td> <td>IGNITION COIL No. 6 (WITH POWER TRANSISTOR)</td> </tr> <tr> <td>Connector Type</td> <td>E03FGY-RS</td> </tr> </table>   <table border="1"> <tr> <td>Terminal No.</td> <td>Color of Wire</td> <td>Signal Name [Specification]</td> </tr> <tr> <td>1</td> <td>GR/R</td> <td>-</td> </tr> <tr> <td>2</td> <td>B</td> <td>-</td> </tr> <tr> <td>3</td> <td>R/B</td> <td>-</td> </tr> </table>	Connector No.	F36	Connector Name	IGNITION COIL No. 6 (WITH POWER TRANSISTOR)	Connector Type	E03FGY-RS	Terminal No.	Color of Wire	Signal Name [Specification]	1	GR/R	-	2	B	-	3	R/B	-	<table border="1"> <tr> <td>Connector No.</td> <td>F37</td> </tr> <tr> <td>Connector Name</td> <td>FUEL INJECTOR No. 1</td> </tr> <tr> <td>Connector Type</td> <td>HS02FGY</td> </tr> </table>   <table border="1"> <tr> <td>Terminal No.</td> <td>Color of Wire</td> <td>Signal Name [Specification]</td> </tr> <tr> <td>1</td> <td>LG</td> <td>-</td> </tr> <tr> <td>2</td> <td>R/B</td> <td>-</td> </tr> </table>	Connector No.	F37	Connector Name	FUEL INJECTOR No. 1	Connector Type	HS02FGY	Terminal No.	Color of Wire	Signal Name [Specification]	1	LG	-	2	R/B	-	<table border="1"> <tr> <td>Connector No.</td> <td>F38</td> </tr> <tr> <td>Connector Name</td> <td>FUEL INJECTOR No. 2</td> </tr> <tr> <td>Connector Type</td> <td>HS02FGY</td> </tr> </table>   <table border="1"> <tr> <td>Terminal No.</td> <td>Color of Wire</td> <td>Signal Name [Specification]</td> </tr> <tr> <td>1</td> <td>Y/G</td> <td>-</td> </tr> <tr> <td>2</td> <td>R/W</td> <td>-</td> </tr> </table>	Connector No.	F38	Connector Name	FUEL INJECTOR No. 2	Connector Type	HS02FGY	Terminal No.	Color of Wire	Signal Name [Specification]	1	Y/G	-	2	R/W	-	<table border="1"> <tr> <td>Connector No.</td> <td>F39</td> </tr> <tr> <td>Connector Name</td> <td>FUEL INJECTOR No. 3</td> </tr> <tr> <td>Connector Type</td> <td>HS02FGY</td> </tr> </table>   <table border="1"> <tr> <td>Terminal No.</td> <td>Color of Wire</td> <td>Signal Name [Specification]</td> </tr> <tr> <td>1</td> <td>LG</td> <td>-</td> </tr> <tr> <td>2</td> <td>R/Y</td> <td>-</td> </tr> </table>	Connector No.	F39	Connector Name	FUEL INJECTOR No. 3	Connector Type	HS02FGY	Terminal No.	Color of Wire	Signal Name [Specification]	1	LG	-	2	R/Y	-	<table border="1"> <tr> <td>Connector No.</td> <td>F40</td> </tr> <tr> <td>Connector Name</td> <td>FUEL INJECTOR No. 4</td> </tr> <tr> <td>Connector Type</td> <td>HS02FGY</td> </tr> </table>   <table border="1"> <tr> <td>Terminal No.</td> <td>Color of Wire</td> <td>Signal Name [Specification]</td> </tr> <tr> <td>1</td> <td>Y/G</td> <td>-</td> </tr> <tr> <td>2</td> <td>LG/R</td> <td>-</td> </tr> </table>	Connector No.	F40	Connector Name	FUEL INJECTOR No. 4	Connector Type	HS02FGY	Terminal No.	Color of Wire	Signal Name [Specification]	1	Y/G	-	2	LG/R	-	<table border="1"> <tr> <td>Connector No.</td> <td>F41</td> </tr> <tr> <td>Connector Name</td> <td>FUEL INJECTOR No. 5</td> </tr> <tr> <td>Connector Type</td> <td>HS02FGY</td> </tr> </table>   <table border="1"> <tr> <td>Terminal No.</td> <td>Color of Wire</td> <td>Signal Name [Specification]</td> </tr> <tr> <td>1</td> <td>LG</td> <td>-</td> </tr> <tr> <td>2</td> <td>L/W</td> <td>-</td> </tr> </table>	Connector No.	F41	Connector Name	FUEL INJECTOR No. 5	Connector Type	HS02FGY	Terminal No.	Color of Wire	Signal Name [Specification]	1	LG	-	2	L/W	-
Connector No.	F34																																																																																																																																							
Connector Name	IGNITION COIL No. 4 (WITH POWER TRANSISTOR)																																																																																																																																							
Connector Type	E03FGY-RS																																																																																																																																							
Terminal No.	Color of Wire	Signal Name [Specification]																																																																																																																																						
1	W	-																																																																																																																																						
2	B	-																																																																																																																																						
3	R/B	-																																																																																																																																						
Connector No.	F35																																																																																																																																							
Connector Name	IGNITION COIL No. 5 (WITH POWER TRANSISTOR)																																																																																																																																							
Connector Type	E03FGY-RS																																																																																																																																							
Terminal No.	Color of Wire	Signal Name [Specification]																																																																																																																																						
1	P	-																																																																																																																																						
2	B	-																																																																																																																																						
3	R/B	-																																																																																																																																						
Connector No.	F36																																																																																																																																							
Connector Name	IGNITION COIL No. 6 (WITH POWER TRANSISTOR)																																																																																																																																							
Connector Type	E03FGY-RS																																																																																																																																							
Terminal No.	Color of Wire	Signal Name [Specification]																																																																																																																																						
1	GR/R	-																																																																																																																																						
2	B	-																																																																																																																																						
3	R/B	-																																																																																																																																						
Connector No.	F37																																																																																																																																							
Connector Name	FUEL INJECTOR No. 1																																																																																																																																							
Connector Type	HS02FGY																																																																																																																																							
Terminal No.	Color of Wire	Signal Name [Specification]																																																																																																																																						
1	LG	-																																																																																																																																						
2	R/B	-																																																																																																																																						
Connector No.	F38																																																																																																																																							
Connector Name	FUEL INJECTOR No. 2																																																																																																																																							
Connector Type	HS02FGY																																																																																																																																							
Terminal No.	Color of Wire	Signal Name [Specification]																																																																																																																																						
1	Y/G	-																																																																																																																																						
2	R/W	-																																																																																																																																						
Connector No.	F39																																																																																																																																							
Connector Name	FUEL INJECTOR No. 3																																																																																																																																							
Connector Type	HS02FGY																																																																																																																																							
Terminal No.	Color of Wire	Signal Name [Specification]																																																																																																																																						
1	LG	-																																																																																																																																						
2	R/Y	-																																																																																																																																						
Connector No.	F40																																																																																																																																							
Connector Name	FUEL INJECTOR No. 4																																																																																																																																							
Connector Type	HS02FGY																																																																																																																																							
Terminal No.	Color of Wire	Signal Name [Specification]																																																																																																																																						
1	Y/G	-																																																																																																																																						
2	LG/R	-																																																																																																																																						
Connector No.	F41																																																																																																																																							
Connector Name	FUEL INJECTOR No. 5																																																																																																																																							
Connector Type	HS02FGY																																																																																																																																							
Terminal No.	Color of Wire	Signal Name [Specification]																																																																																																																																						
1	LG	-																																																																																																																																						
2	L/W	-																																																																																																																																						

JCBWM1047G1

ENGINE CONTROL SYSTEM (TYPE A)

Connector No. F42	FUEL INJECTOR No. 6	HS.	1 2	Terminal No.	Color of Wire	Signal Name [Specification]
Connector Name	HS2EFGY			1	Y/G	-
Connector Type				2	P/B	-
Connector No. F66	ENGINE OIL TEMPERATURE SENSOR	HS.	1 2	Terminal No.	Color of Wire	Signal Name [Specification]
Connector Name	EO2EFGY-RS			1	G	-
Connector Type				2	B	-
Connector No. F64	AIR FUEL RATIO (A/F) SENSOR 1 (BANK 2)	HS.	1 2 3 4	Terminal No.	Color of Wire	Signal Name [Specification]
Connector Name	AFZ04FB			1	V	-
Connector Type				2	LG	-
				3	SB	-
				4	O	-
Connector No. F70	HEATED OXYGEN SENSOR 2 (BANK 1)	HS.	1 2 3 4	Terminal No.	Color of Wire	Signal Name [Specification]
Connector Name	AFZ04FB			1	B/P	-
Connector Type				2	O/B	-
				3	SB	-
				4	W	-
Connector No. F74	VIAS CONTROL SOLENOID VALVE 1	HS.	1 2	Terminal No.	Color of Wire	Signal Name [Specification]
Connector Name	EO2FB-RS			1	R/W	-
Connector Type				2	V	-
Connector No. F71	HEATED OXYGEN SENSOR 2 (BANK 2)	HS.	1 2 3 4	Terminal No.	Color of Wire	Signal Name [Specification]
Connector Name	AFZ04FB			1	B	-
Connector Type				2	R/Y	-
				3	R	-
				4	W/L	-
Connector No. F70	HEATED OXYGEN SENSOR 2 (BANK 1)	HS.	1 2 3 4	Terminal No.	Color of Wire	Signal Name [Specification]
Connector Name	AFZ04FB			1	B	-
Connector Type				2	R/Y	-
				3	P/B	-
				4	W	-
Connector No. F89	CAMSHAFT POSITION SENSOR (PHASE) (BANK 2)	HS.	1 2 3	Terminal No.	Color of Wire	Signal Name [Specification]
Connector Name	RH03FB			1	R/W	-
Connector Type				2	Y/G	-
				3	BR/W	-

JCBWM10486I

A
EC
C
D
E
F
G
H
I
J
K
L
M
N
O
P

ENGINE CONTROL SYSTEM (TYPE A)

Connector No.	F75
Connector Name	WAS CONTROL SOLENOID VALVE 2
Connector Type	ED2FB-RS



Terminal No.	Color of Wire	Signal Name [Specification]
1	R/W	-
2	GR/R	-(Type A)

Connector No.	F76
Connector Name	BATTERY CURRENT SENSOR
Connector Type	RI40FB



Terminal No.	Color of Wire	Signal Name [Specification]
1	R/Y	-
2	G/B	-
3	BR	-

Connector No.	F78
Connector Name	WIRE TO WIRE
Connector Type	RS4FL-B



Terminal No.	Color of Wire	Signal Name [Specification]
1	B	-
2	SHIELD	-
3	W	-
4	SHIELD	-

Connector No.	F80
Connector Name	ENGINE COOLANT TEMPERATURE SENSOR
Connector Type	ED2FGY-RS



Terminal No.	Color of Wire	Signal Name [Specification]
1	Y	-
2	B/R	-

Connector No.	F81
Connector Name	INTAKE VALVE TIMING CONTROL SOLENOID VALVE (BANK 1)
Connector Type	ED2FG-RS-LGY



Terminal No.	Color of Wire	Signal Name [Specification]
1	R/L	-
2	R/W	-

Connector No.	F82
Connector Name	INTAKE VALVE TIMING CONTROL SOLENOID VALVE (BANK 2)
Connector Type	ED2FG-RS-LGY



Terminal No.	Color of Wire	Signal Name [Specification]
1	Y	-
2	R/W	-

Connector No.	F121
Connector Name	WIRE TO WIRE
Connector Type	NS10FW-GS



Terminal No.	Color of Wire	Signal Name [Specification]
1	B/Y	-
2	R/Y	-
5	R/W	-
6	B	-
7	R/G	-

Connector No.	F123
Connector Name	WIRE TO WIRE
Connector Type	TK16FGY-IV



Terminal No.	Color of Wire	Signal Name [Specification]
1	L	-
3	G/R	-
5	R	-
8	P	-
11	BR/W	-
13	G	-

ENGINE CONTROL SYSTEM (TYPE A)

Connector No.	F200
Connector Name	WIRE TO WIRE
Connector Type	RSQ4ML



Terminal No.	Color of Wire	Signal Name [Specification]
1	W	-
2	SHIELD	-
3	W	-
4	SHIELD	-

Connector No.	F201
Connector Name	KNOCK SENSOR (BANK 1)
Connector Type	E02FG-RS



Terminal No.	Color of Wire	Signal Name [Specification]
1	W	-
2	SHIELD	-

Connector No.	F202
Connector Name	KNOCK SENSOR (BANK 2)
Connector Type	E02FG-RS



Terminal No.	Color of Wire	Signal Name [Specification]
1	W	-
2	SHIELD	-

Connector No.	M1
Connector Name	FUSE BLOCK (J/B)
Connector Type	NS08FW-M2



Terminal No.	Color of Wire	Signal Name [Specification]
2A	G	-

Connector No.	M2
Connector Name	FUSE BLOCK (J/B)
Connector Type	NS10FW-CS



Terminal No.	Color of Wire	Signal Name [Specification]
6B	Y	-

Connector No.	M4
Connector Name	DATA LINK CONNECTOR
Connector Type	BD18FW

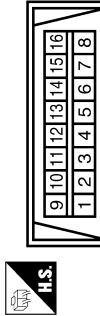

Terminal No.	Color of Wire	Signal Name [Specification]
4	B	-
5	B	-
6	L	-
7	O	-
8	G	-
14	P	-
16	Y	-

Connector No.	M11
Connector Name	WIRE TO WIRE
Connector Type	TH10FW-CS10-M3



Terminal No.	Color of Wire	Signal Name [Specification]
11	P	-
12	L	-
47	P	-
48	L	-
49	W	-
53	V	-
54	SB	-
55	P	-
82	O	-

Connector No.	M33
Connector Name	COMBINATION SWITCH (SPIRAL CABLE)
Connector Type	TK08FGY-TV



Terminal No.	Color of Wire	Signal Name [Specification]
25	P	-
32	SB	-

A
EC
C
D
E
F
G
H
I
J
K
L
M
N
O
P

ENGINE CONTROL SYSTEM (TYPE A)

Connector No.	M303
Connector Name	COMBINATION SWITCH (SPIRAL CABLE)
Connector Type	TK08FGY



Terminal No.	Color of Wire	Signal Name [Specification]
13	-	-
16	-	-

Connector No.	M77
Connector Name	WIRE TO WIRE
Connector Type	TH00FW-CS19

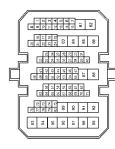

Terminal No.	Color of Wire	Signal Name [Specification]
6	W	-
56	P	-
57	L	-

Connector No.	M61
Connector Name	POWER STEERING CONTROL UNIT
Connector Type	TH12FW-NH

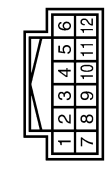

Terminal No.	Color of Wire	Signal Name [Specification]
10	V	ENG TACHO

Connector No.	M34
Connector Name	COMBINATION METER
Connector Type	TH40FW-NH

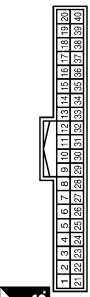

Terminal No.	Color of Wire	Signal Name [Specification]
21	L	CAN-H
22	P	CAN-L
24	W	FUEL LEVEL SENSOR GROUND

JCBWM1051Gf

From VIN: JN8AZ18U*9W100001, JN8AZ18W*9W200001 (EXCEPT FOR MEXICO),

JN8AZ18U*9W710001, JN8AZ18W*9W810001 (FOR MEXICO)

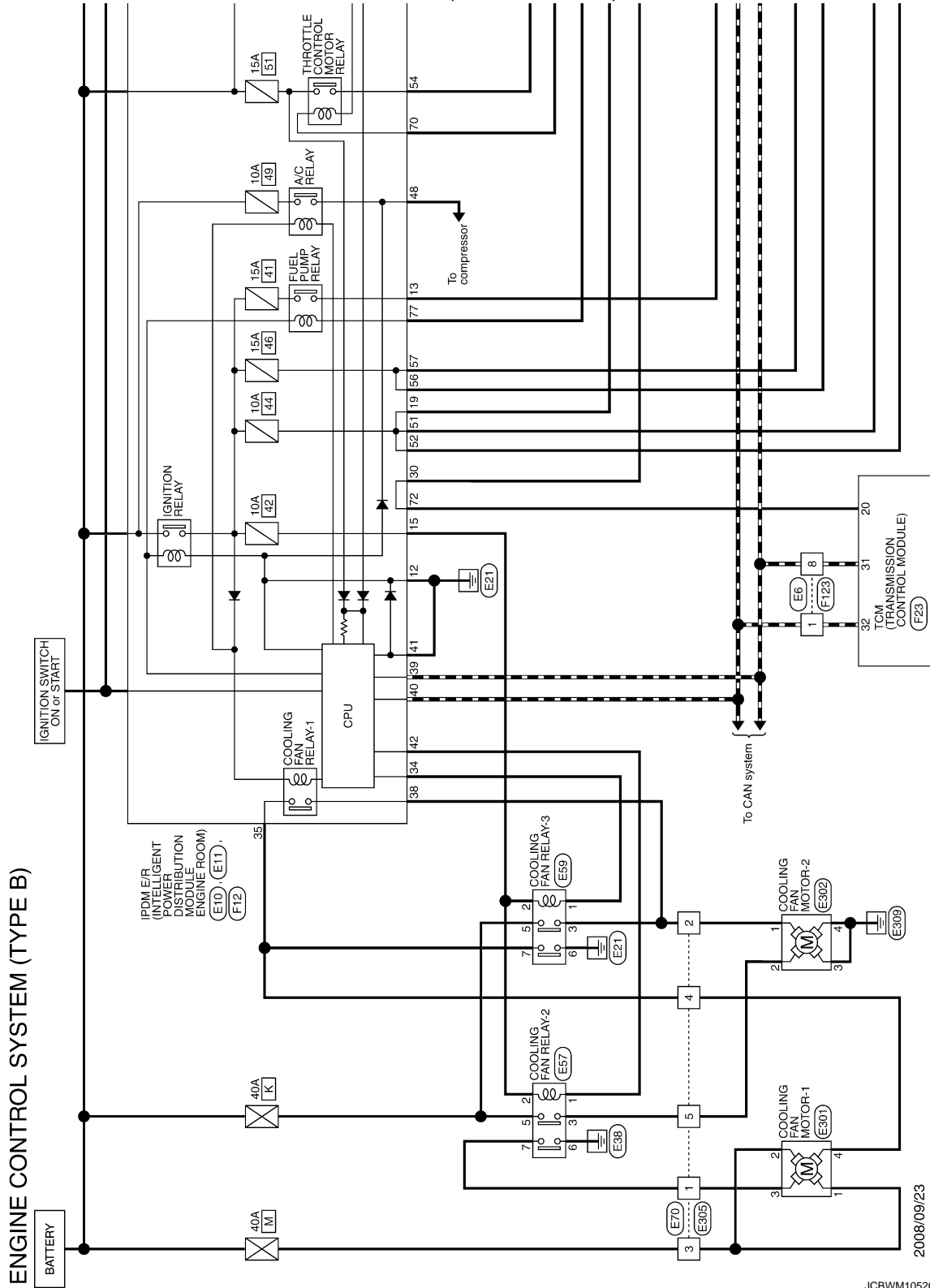

A
EC
 C
 D
 E
 F
 G
 H
 I
 J
 K
 L
 M
 N
 O
 P

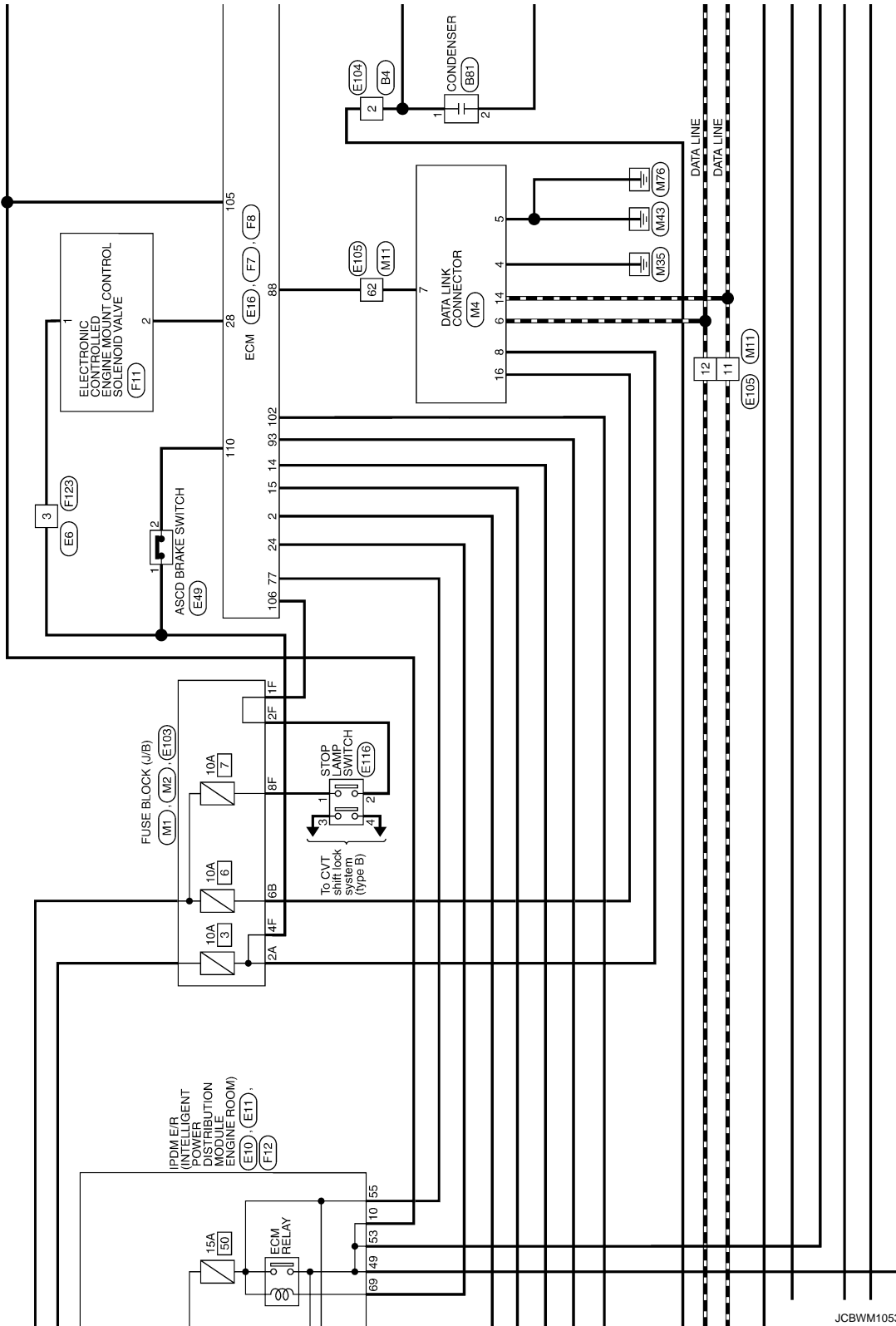

JCBWM1053Gf

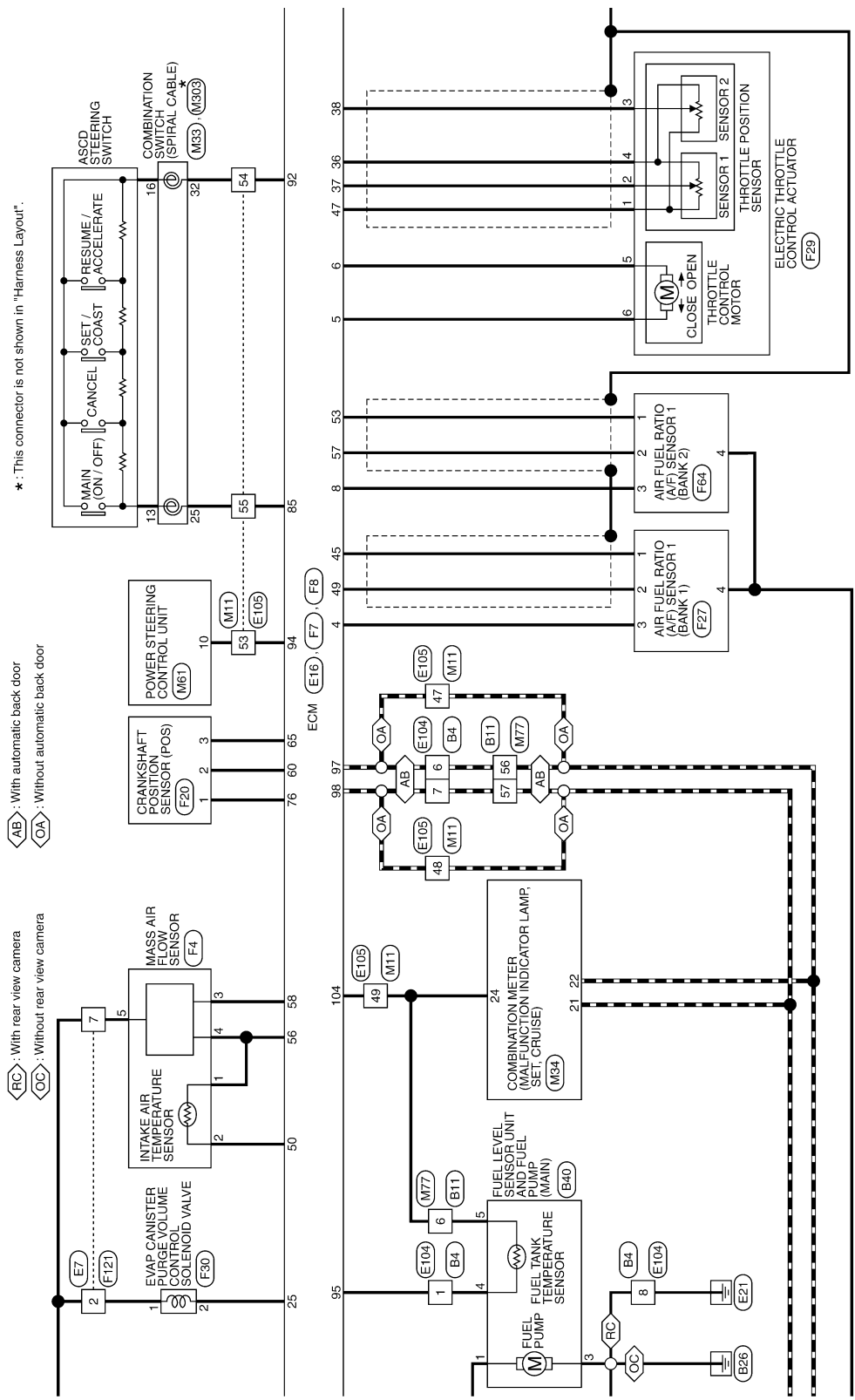

JCBWM1054GI

A
EC
 C
 D
 E
 F
 G
 H
 I
 J
 K
 L
 M
 N
 O
 P

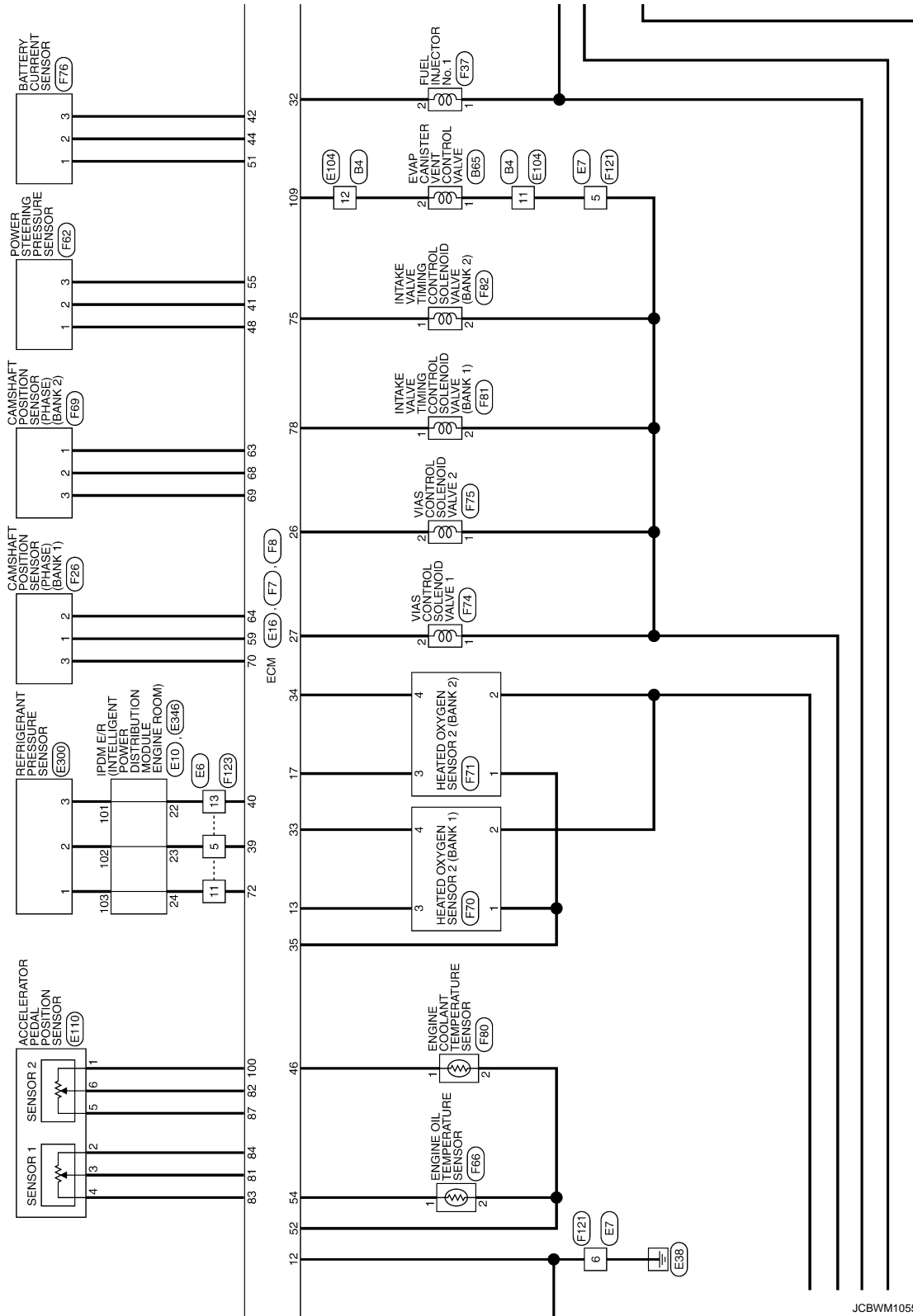

JCBWM1055G1

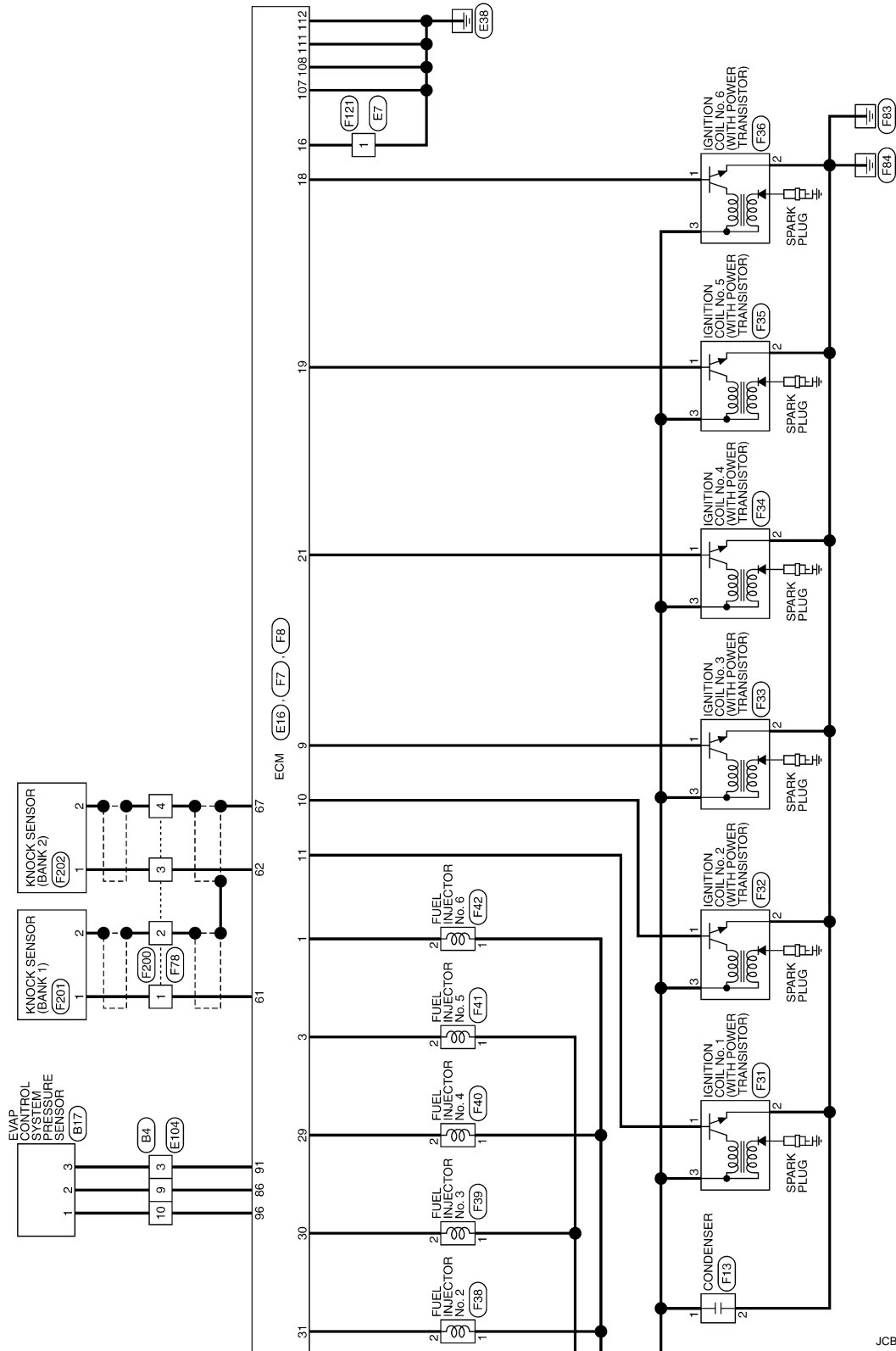

JCBWM1056G1

A
EC
C
D
E
F
G
H
I
J
K
L
M
N
O
P

ENGINE CONTROL SYSTEM (TYPE B)

Connector No.	B4
Connector Name	WIRE TO WIRE
Connector Type	NS16MW-CS

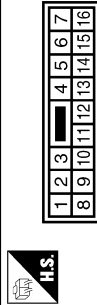

Terminal No.	Color of Wire	Signal Name [Specification]
1	SB	-
2	W	-
3	W	-
6	P	-
7	L	-
8	B	-
9	LG	-
10	V	-
11	L	-
12	BR	-

Connector No.	B85
Connector Name	EVAP CANISTER VENT CONTROL VALVE
Connector Type	ED2FE-RS



Terminal No.	Color of Wire	Signal Name [Specification]
1	L	-
2	BR	-

Connector No.	B11
Connector Name	WIRE TO WIRE
Connector Type	TH80MW-CS19

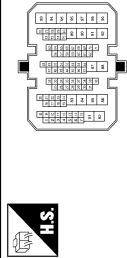

Terminal No.	Color of Wire	Signal Name [Specification]
6	P	-
56	P	-
57	L	-

Connector No.	B81
Connector Name	CONDENSER
Connector Type	M02FW-LC



Terminal No.	Color of Wire	Signal Name [Specification]
1	W	-
2	B	-

Connector No.	B17
Connector Name	EVAP CONTROL SYSTEM PRESSURE SENSOR
Connector Type	E03FGY-RS

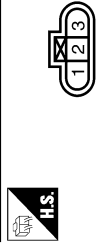

Terminal No.	Color of Wire	Signal Name [Specification]
1	V	-
2	LG	-
3	W	-

Connector No.	E6
Connector Name	WIRE TO WIRE
Connector Type	TK16MGY-IV

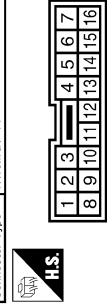

Terminal No.	Color of Wire	Signal Name [Specification]
1	L	-
3	Y	-
5	GR	-
8	P	-
11	G	-
13	SB	-

Connector No.	B40
Connector Name	FUEL LEVEL SENSOR UNIT AND FUEL PUMP
Connector Type	E05FGY-RS

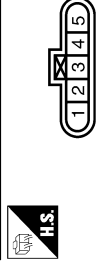

Terminal No.	Color of Wire	Signal Name [Specification]
1	W	-
3	B	-
4	SB	-
5	P	-

Connector No.	E7
Connector Name	WIRE TO WIRE
Connector Type	NS10MW-CS

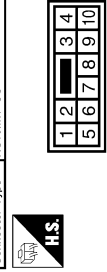

Terminal No.	Color of Wire	Signal Name [Specification]
1	B	-
2	L	-
5	R	-
6	B	-
7	O	-

ENGINE CONTROL SYSTEM (TYPE B)

Connector No.	E10
Connector Name	IPDM E/R (INTELLIGENT POWER DISTRIBUTION MODULE ENGINE ROOM)
Connector Type	TH20PW-CS12-M4-TV

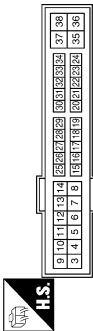

Terminal No.	Color of Wire	Signal Name [Specification]
10	BR	-
12	B	-
13	SB	-
15	W	-
18	Y	-
22	SB	-
23	GR	-
24	G	-
30	BR	-
34	O	-
35	P	-

Connector No.	E16
Connector Name	ECM
Connector Type	RH24FB-RZ8-L-LH

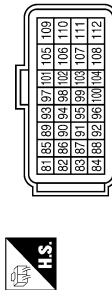

Terminal No.	Color of Wire	Signal Name [Specification]
81	W	APSI
82	O	APSZ
83	BR	AVCC1-APSI
84	B	GND1-APSI
85	Y	ASCD SW
86	SB	FTPRES
87	GR	AVCC2-APSZ
88	O	KLINE
91	L	AVCC2-FTPRES
92	BR	GND1-ASCD SW
93	BR	IGN SW

38	GR	-
----	----	---

Connector No.	E11
Connector Name	IPDM E/R (INTELLIGENT POWER DISTRIBUTION MODULE ENGINE ROOM)
Connector Type	TH20PW-NH

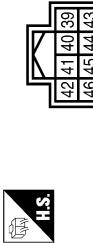

Terminal No.	Color of Wire	Signal Name [Specification]
39	P	-
40	L	-
41	B	-
42	SB	-

Connector No.	E49
Connector Name	ASCD BRAKE SWITCH
Connector Type	MD2FER-LC



Terminal No.	Color of Wire	Signal Name [Specification]
1	R	-
2	G	-

94	GR	TACHO(CABIN)
95	Y	TF
96	GR	GND1-FTPRES
97	P	VEHGAN-L
98	L	VEHGAN-H
100	G	GND1-APSZ
102	R	NEUT-H
104	SB	GND1-TF
106	V	VGR
108	SB	BRAKE
107	B	GND
108	B	GND
109	W	GDCV
110	G	BNGSW
111	B	GND
112	B	GND

Connector No.	E57
Connector Name	COOLING FAN RELAY-2
Connector Type	MD2FER-R-LC



Terminal No.	Color of Wire	Signal Name [Specification]
1	SB	-
2	G	-
3	L	-
5	Y	-
6	B	-
7	R	-

JCBWM10586I

A
EC
C
D
E
F
G
H
I
J
K
L
M
N
O
P

ENGINE CONTROL SYSTEM (TYPE B)

Connector No.	E104
Connector Name	WIRE TO WIRE
Connector Type	NS3.6FW-CS



Terminal No.	Color of Wire	Signal Name [Specification]
1	Y	-
2	SB	-
3	L	-
6	P	-
7	L	-
8	B/W	-
9	SB	-
10	GR	-
11	R	-
12	W	-

Connector No.	E103
Connector Name	FUSE BLOCK (U/B)
Connector Type	NS3.6FW-CS



Terminal No.	Color of Wire	Signal Name [Specification]
1F	L	-
2F	LG	-
4F	BR	-
8F	R	-

Connector No.	E10
Connector Name	WIRE TO WIRE
Connector Type	M06AW-LC



Terminal No.	Color of Wire	Signal Name [Specification]
1	R	-
2	GR	-
3	BR	-
4	P	-
5	L	-

Connector No.	E59
Connector Name	COOLING FAN RELAY-3
Connector Type	M06EBR-R-LC



Terminal No.	Color of Wire	Signal Name [Specification]
1	O	-
2	Y	-
3	GR	-
5	Y	-
6	B	-
7	P	-

Connector No.	E300
Connector Name	REFRIGERANT PRESSURE SENSOR
Connector Type	RK03FB



Terminal No.	Color of Wire	Signal Name [Specification]
1	P	-
2	B	-
3	L	-

Connector No.	E116
Connector Name	STOP LAMP SWITCH (TYPE B)
Connector Type	M04FW-LC



Terminal No.	Color of Wire	Signal Name [Specification]
1	R	-
2	LG	-
3	G	-
4	Y	-

Connector No.	E110
Connector Name	ACCELERATOR PEDAL POSITION SENSOR
Connector Type	RH06FB

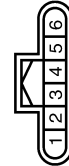

Terminal No.	Color of Wire	Signal Name [Specification]
1	G	-
2	B	-
3	W	-
4	BR	-
5	GR	-
6	O	-

Connector No.	E105
Connector Name	WIRE TO WIRE
Connector Type	TH70MW-CS10-M3



Terminal No.	Color of Wire	Signal Name [Specification]
11	P	-
12	L	-
47	P	-
48	L	-
49	SB	-
53	GR	-
54	BR	-
55	Y	-
62	O	-

JCBWM1059G1

ENGINE CONTROL SYSTEM (TYPE B)

Connector No.	E59
Connector Name	COOLING FAN RELAY-3
Connector Type	MD6FR-R-LC



Terminal No.	Color of Wire	Signal Name [Specification]
1	O	-
2	Y	-
3	GR	-
5	Y	-
6	B	-
7	P	-

Connector No.	E70
Connector Name	WIRE TO WIRE
Connector Type	MD6MW-LC

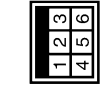

Terminal No.	Color of Wire	Signal Name [Specification]
1	R	-
2	GR	-
3	BR	-
4	P	-
5	L	-

Connector No.	E103
Connector Name	FUSE BLOCK (J/B)
Connector Type	NS16FW-CS

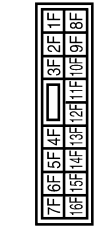

Terminal No.	Color of Wire	Signal Name [Specification]
1F	L	-
2F	LG	-
4F	BR	-
8F	R	-

Connector No.	E104
Connector Name	WIRE TO WIRE
Connector Type	NS16FW-CS

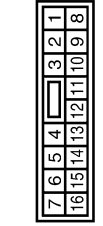

Terminal No.	Color of Wire	Signal Name [Specification]
1	Y	-
2	SB	-
3	L	-
6	P	-
7	L	-
8	B/W	-
9	SB	-
10	GR	-
11	R	-
12	W	-

Connector No.	E105
Connector Name	WIRE TO WIRE
Connector Type	TH170MW-CS10-M3

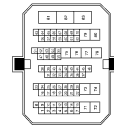

Terminal No.	Color of Wire	Signal Name [Specification]
11	P	-
12	L	-
47	P	-
48	L	-
49	SB	-
53	GR	-
54	BR	-
55	Y	-
62	O	-

Connector No.	E110
Connector Name	ACCELERATOR PEDAL POSITION SENSOR
Connector Type	RH06FB

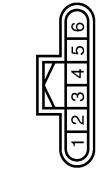

Terminal No.	Color of Wire	Signal Name [Specification]
1	G	-
2	B	-
3	W	-
4	BR	-
5	GR	-
6	O	-

Connector No.	E116
Connector Name	STOP LAMP SWITCH (TYPE B)
Connector Type	MD4FW-LC



Terminal No.	Color of Wire	Signal Name [Specification]
1	R	-
2	LG	-
3	G	-
4	Y	-

Connector No.	E300
Connector Name	REFRIGERANT PRESSURE SENSOR
Connector Type	RK03FB



Terminal No.	Color of Wire	Signal Name [Specification]
1	P	-
2	B	-
3	L	-

JCBWM1059Gf

A
EC
C
D
E
F
G
H
I
J
K
L
M
N
O
P

ENGINE CONTROL SYSTEM (TYPE B)

Connector No.	E301
Connector Name	COOLING FAN MOTOR-1
Connector Type	RSM4FGY-PR



Terminal No.	Color of Wire	Signal Name [Specification]
1	L	-
2	L	-
3	R	-
4	G	-

Connector No.	E302
Connector Name	COOLING FAN MOTOR-2
Connector Type	RSM4FGY-PR



Terminal No.	Color of Wire	Signal Name [Specification]
1	BR	-
2	L	-
3	B	-
4	B	-

Connector No.	E305
Connector Name	WIRE TO WIRE
Connector Type	M08FW-LC



Terminal No.	Color of Wire	Signal Name [Specification]
1	R	-
2	BR	-
3	L	-
4	G	-
5	L	-

Connector No.	E348
Connector Name	IPDM E/R (INTELLIGENT POWER DISTRIBUTION MODULE ENGINE ROOM)
Connector Type	TH116FW-NH



Terminal No.	Color of Wire	Signal Name [Specification]
101	L	-
102	B	-
103	P	-

Connector No.	F4
Connector Name	MASS AIR FLOW SENSOR
Connector Type	RH06FB

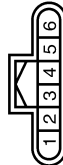

Terminal No.	Color of Wire	Signal Name [Specification]
1	G/B	-
2	L/Y	-
3	O	-
4	G/B	-
5	R/G	-

Connector No.	F7
Connector Name	ECM
Connector Type	RH24FGY-RZ8-R-LH



Terminal No.	Color of Wire	Signal Name [Specification]
1	P/B	INJ#6
2	G/W	VMOT-B1
3	L/W	INJ#5
4	BR/Y	AFH1
5	L	MOTOR1-B1
6	P	MOTOR2-B1
8	SB	AFH2
9	L/B	IGN#3
10	G/R	IGN#2
11	Y/R	IGN#1
12	B	GND

13	P/B	O2HR1
14	GR	FPR
15	O	MOTRLY-B1
16	B/Y	GND
17	R	O2HR2
18	GR/R	IGN#6
19	P	IGN#5
21	W	IGN#4
24	W/B	SSOFF
25	P/L	EVAP
26	GR/B	MASS [Type B]
27	V	VAS1
28	BR/W	EMMRV
29	LG/R	INJ#4
30	R/Y	INJ#3
31	R/W	INJ#2
32	R/B	INJ#1

ENGINE CONTROL SYSTEM (TYPE B)

Connector No.	F8
Connector Name	ECM
Connector Type	RH40FB-R2B-L-LH

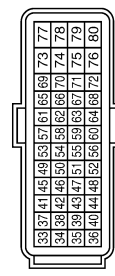

Terminal No.	Color of Wire	Signal Name [Specification]
33	W	O2SR1
34	W/L	O2SR2
35	B	GND-O2SR1 O2SR2
36	B	GND-TPS-B1
37	W	TPS-L-B1
38	R	TPS2-B1
39	R	PPRES
40	G	GND-PPRES
41	O/B	PSPRES
42	BR	CURSEN
44	G/B	GND-CURSINTP

Connector No.	F12
Connector Name	IPDM E/R (INTELLIGENT POWER DISTRIBUTION MODULE ENGINE ROOM)
Connector Type	TH20FW-CS12-M4

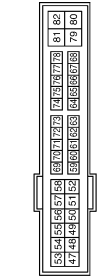

Terminal No.	Color of Wire	Signal Name [Specification]
48	W	-
49	R/B	-
51	LG	-
52	Y/G	-
53	R/W	-
54	G/W	-
55	W/L	-
56	R/Y	-
57	O	-
68	W/B	-
70	O	-

45	P	AF+1
46	Y	TW
47	G	AVCCI-TPS-B1
48	B/P	GND-PPRES
49	L	AF-1
50	L/Y	TA1
51	R/Y	AVCCI-CURSINTP
52	B/R	GND-TW101
53	V	AF-2
54	G	TO1
55	SB	AVCCI-PSPRES
56	G/B	QA-GND-A1
57	LG	AF-2
58	O	QA1+
59	G/W	AVCCI-PHASE1EP1
60	Y/B	GND-POS
61	B	KNK1
62	W	KNK2
63	R/W	AVCCI-PHASE2EP2
64	B/R	GND-PHASE1EP1
65	W/B	POS
67	SHIELD	GND-KNK1.KNK2
68	Y/G	GND-PHASE2EP2
69	BR/W	PHASE2
70	W/R	PHASE1

72	R/B	-
77	GR	-

72	BR/W	AVCC2-PPRES
75	Y	CVTCH2
76	R/G	AVCC2-POS
77	W/L	BA11
78	R/L	CVTCH1



Connector No.	F11
Connector Name	ELECTRONIC CONTROLLED ENGINE INQUIRY CONTROL SOLENOID VALVE
Connector Type	EQ2FBR-RS

Terminal No.	Color of Wire	Signal Name [Specification]
1	G/R	-
2	BR/W	-

Connector No.	F13
Connector Name	CONDENSER
Connector Type	M02FW-GY-LC



Connector No.	F20
Connector Name	CRANKSHAFT POSITION SENSOR (POS)
Connector Type	RH03FB



Terminal No.	Color of Wire	Signal Name [Specification]
1	R/B	-
2	B	-

Terminal No.	Color of Wire	Signal Name [Specification]
1	R/G	-
2	Y/B	-
3	W/B	-

A
EC
C
D
E
F
G
H
I
J
K
L
M
N
O
P

JCBWM1061G1

ENGINE CONTROL SYSTEM (TYPE B)

Connector No.	F29
Connector Name	ELECTRIC THROTTLE CONTROL ACTUATOR
Connector Type	RH06FB

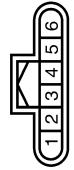

Terminal No.	Color of Wire	Signal Name [Specification]
1	G	INPUT
2	W	OUTPUT1
3	R	OUTPUT2
4	B	GND
5	P	MOTOR(CLOSE)
6	L	MOTOR(OPEN)

Connector No.	F27
Connector Name	AIR FUEL RATIO (A/F) SENSOR 1 (BANK 1)
Connector Type	AF204FB



Terminal No.	Color of Wire	Signal Name [Specification]
1	P	-
2	L	-
3	BR/Y	-
4	O	-

Connector No.	F26
Connector Name	CAMSHAFT POSITION SENSOR (PHASE) (BANK 1)
Connector Type	RH03FB



Terminal No.	Color of Wire	Signal Name [Specification]
1	G/W	-
2	B/R	-
3	W/R	-

Connector No.	F23
Connector Name	TCM (TRANSMISSION CONTROL MODULE)
Connector Type	RH40FB-R28-L-RH

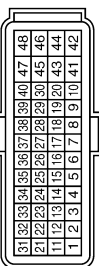

Terminal No.	Color of Wire	Signal Name [Specification]
20	R/B	STARTER RELAY
31	P	CAN-L
32	L	CAN-H

Connector No.	F33
Connector Name	IGNITION COIL No. 3 (WITH POWER TRANSISTOR)
Connector Type	EQ3FGY-RS



Connector No.	F32
Connector Name	IGNITION COIL No. 2 (WITH POWER TRANSISTOR)
Connector Type	EQ3FGY-RS



Connector No.	F31
Connector Name	IGNITION COIL No. 1 (WITH POWER TRANSISTOR)
Connector Type	EQ3FGY-RS



Connector No.	F30
Connector Name	EVAP CANISTER PURGE VOLUME CONTROL SOLENOID VALVE
Connector Type	EQ2FL-RS-LGY



Terminal No.	Color of Wire	Signal Name [Specification]
1	L/B	-
2	B	-
3	R/B	-

Terminal No.	Color of Wire	Signal Name [Specification]
1	G/R	-
2	B	-
3	R/B	-

Terminal No.	Color of Wire	Signal Name [Specification]
1	Y/R	-
2	B	-
3	R/B	-

Terminal No.	Color of Wire	Signal Name [Specification]
1	R/Y	-
2	P/L	-

ENGINE CONTROL SYSTEM (TYPE B)

Connector No.	F34
Connector Name	IGNITION COIL No. 4 (WITH POWER TRANSISTOR)
Connector Type	EG3FGY-RS



Terminal No.	Color of Wire	Signal Name [Specification]
1	W	-
2	B	-
3	R/B	-

Connector No.	F35
Connector Name	IGNITION COIL No. 5 (WITH POWER TRANSISTOR)
Connector Type	EG3FGY-RS



Terminal No.	Color of Wire	Signal Name [Specification]
1	P	-
2	B	-
3	R/B	-

Connector No.	F36
Connector Name	IGNITION COIL No. 6 (WITH POWER TRANSISTOR)
Connector Type	EG3FGY-RS



Terminal No.	Color of Wire	Signal Name [Specification]
1	GR/R	-
2	B	-
3	R/B	-

Connector No.	F37
Connector Name	FUEL INJECTOR No. 1
Connector Type	HS02FGY



Terminal No.	Color of Wire	Signal Name [Specification]
1	LG	-
2	R/B	-

Connector No.	F38
Connector Name	FUEL INJECTOR No. 2
Connector Type	HS02FGY



Terminal No.	Color of Wire	Signal Name [Specification]
1	Y/G	-
2	R/W	-

Connector No.	F39
Connector Name	FUEL INJECTOR No. 3
Connector Type	HS02FGY



Terminal No.	Color of Wire	Signal Name [Specification]
1	LG	-
2	R/Y	-

Connector No.	F40
Connector Name	FUEL INJECTOR No. 4
Connector Type	HS02FGY



Terminal No.	Color of Wire	Signal Name [Specification]
1	Y/G	-
2	LG/R	-







Connector No.	F41
Connector Name	FUEL INJECTOR No. 5
Connector Type	HS02FGY



Terminal No.	Color of Wire	Signal Name [Specification]
1	LG	-
2	L/W	-

A
EC
C
D
E
F
G
H
I
J
K
L
M
N
O
P

ENGINE CONTROL SYSTEM (TYPE B)

Connector No. F42	FUEL INJECTOR No. 6	HS		Terminal No.	Color of Wire	Signal Name [Specification]
Connector Name	HS2FGY			1	Y/G	-
Connector Type				2	P/B	-
Connector No. F66	ENGINE OIL TEMPERATURE SENSOR	HS		Terminal No.	Color of Wire	Signal Name [Specification]
Connector Name	ED2FGY-RS			1	G	-
Connector Type				2	B	-
Connector No. F64	AIR FUEL RATIO (A/F) SENSOR 1 (BANK 2)	HS		Terminal No.	Color of Wire	Signal Name [Specification]
Connector Name	AFZ04FB			1	V	-
Connector Type				2	LG	-
				3	SB	-
				4	O	-
Connector No. F70	HEATED OXYGEN SENSOR 2 (BANK 1)	HS		Terminal No.	Color of Wire	Signal Name [Specification]
Connector Name	AFZ04FB			1	B/P	-
Connector Type				2	O/B	-
				3	SB	-
Connector No. F71	HEATED OXYGEN SENSOR 2 (BANK 2)	HS		Terminal No.	Color of Wire	Signal Name [Specification]
Connector Name	AFZ04FB			1	B	-
Connector Type				2	R/Y	-
				3	R	-
				4	W/L	-
Connector No. F69	CAMSHAFT POSITION SENSOR (PHASE) (BANK 2)	HS		Terminal No.	Color of Wire	Signal Name [Specification]
Connector Name	RH03FB			1	R/W	-
Connector Type				2	Y/G	-
				3	BR/W	-
Connector No. F74	VIAS CONTROL SOLENOID VALVE 1	HS		Terminal No.	Color of Wire	Signal Name [Specification]
Connector Name	ED2FB-RS			1	R/W	-
Connector Type				2	V	-

JCBWM1064GI

ENGINE CONTROL SYSTEM (TYPE B)

Connector No.	F75
Connector Name	WAS CONTROL SOLENOID VALVE 2
Connector Type	ED2FE-RS



Terminal No.	Color of Wire	Signal Name [Specification]
1	R/W	-
2	GR/B	- [Type B]

Connector No.	F76
Connector Name	BATTERY CURRENT SENSOR
Connector Type	RH03FB



Terminal No.	Color of Wire	Signal Name [Specification]
1	R/Y	-
2	G/B	-
3	BR	-

Connector No.	F78
Connector Name	WIRE TO WIRE
Connector Type	RS4FL-B



Terminal No.	Color of Wire	Signal Name [Specification]
1	B	-
2	SHIELD	-
3	W	-
4	SHIELD	-

Connector No.	F80
Connector Name	ENGINE COOLANT TEMPERATURE SENSOR
Connector Type	ED2FGY-RS



Terminal No.	Color of Wire	Signal Name [Specification]
1	Y	-
2	B/R	-

Connector No.	F81
Connector Name	INTAKE VALVE TIMING CONTROL SOLENOID VALVE (BANK 1)
Connector Type	ED2FG-RS-LGY



Terminal No.	Color of Wire	Signal Name [Specification]
1	R/L	-
2	R/W	-

Connector No.	F82
Connector Name	INTAKE VALVE TIMING CONTROL SOLENOID VALVE (BANK 2)
Connector Type	ED2FG-RS-LGY



Terminal No.	Color of Wire	Signal Name [Specification]
1	Y	-
2	R/W	-

Connector No.	F121
Connector Name	WIRE TO WIRE
Connector Type	NS10FW-CS



Terminal No.	Color of Wire	Signal Name [Specification]
1	B/Y	-
2	R/Y	-
5	R/W	-
6	B	-
7	R/G	-

Connector No.	F123
Connector Name	WIRE TO WIRE
Connector Type	TK16FGY-TV



Terminal No.	Color of Wire	Signal Name [Specification]
1	L	-
3	G/R	-
5	R	-
8	P	-
11	BR/W	-
13	G	-

A
EC
C
D
E
F
G
H
I
J
K
L
M
N
O
P

JCBWM1065GI

ENGINE CONTROL SYSTEM (TYPE B)

Connector No.	M1
Connector Name	FUSE BLOCK (J/B)
Connector Type	NS30FW-M2



Terminal No.	Color of Wire	Signal Name [Specification]
2A	G	

Connector No.	F202
Connector Name	KNOCK SENSOR (BANK 2)
Connector Type	E02FG-RS



Terminal No.	Color of Wire	Signal Name [Specification]
1	W	
2	SHIELD	

Connector No.	F201
Connector Name	KNOCK SENSOR (BANK 1)
Connector Type	E02FG-RS



Terminal No.	Color of Wire	Signal Name [Specification]
1	W	
2	SHIELD	

Connector No.	F200
Connector Name	WIRE TO WIRE
Connector Type	RS04ML



Terminal No.	Color of Wire	Signal Name [Specification]
1	W	
2	SHIELD	
3	W	
4	SHIELD	

Connector No.	M33
Connector Name	COMBINATION SWITCH (SPIRAL CABLE)
Connector Type	TK08FGY-IV



Terminal No.	Color of Wire	Signal Name [Specification]
25	P	
32	SB	

Connector No.	M11
Connector Name	WIRE TO WIRE
Connector Type	TH70FW-GS10-M3



Terminal No.	Color of Wire	Signal Name [Specification]
11	P	
12	L	
47	P	
48	L	
49	W	
53	V	
54	SB	
55	P	
62	O	

Connector No.	M4
Connector Name	DATA LINK CONNECTOR
Connector Type	BD16FW

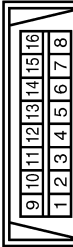

Terminal No.	Color of Wire	Signal Name [Specification]
4	B	
5	B	
6	L	
7	O	
8	G	
14	P	
16	Y	

Connector No.	M2
Connector Name	FUSE BLOCK (J/B)
Connector Type	NS10FW-CS



Terminal No.	Color of Wire	Signal Name [Specification]
8B	Y	

JCBWM1066G1

A

EC

C

D

E

F

G

H

I

J

K

L

M

N

O

P

ENGINE CONTROL SYSTEM (TYPE B)

Connector No.	M303
Connector Name	COMBINATION SWITCH (SPIRAL CABLE)
Connector Type	TK08FGY



Terminal No.	Color of Wire	Signal Name [Specification]
13	-	-
16	-	-

Connector No.	M77
Connector Name	WIRE TO WIRE
Connector Type	TH08FW-CS19

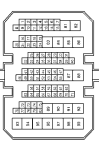

Terminal No.	Color of Wire	Signal Name [Specification]
6	W	-
56	P	-
57	L	-

Connector No.	M61
Connector Name	POWER STEERING CONTROL UNIT
Connector Type	TH12FW-NH

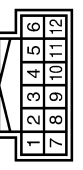

Terminal No.	Color of Wire	Signal Name [Specification]
10	V	ENG TACHO

Connector No.	M34
Connector Name	COMBINATION METER
Connector Type	TH08FW-NH

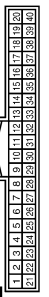

Terminal No.	Color of Wire	Signal Name [Specification]
21	L	CAN-H
22	P	CAN-L
24	W	FUEL LEVEL SENSOR GROUND

Fail-safe

NON DTC RELATED ITEM

JCBWM1067G1

INFOID:000000003388287

ECM

< ECU DIAGNOSIS >

[VQ35DE]

Engine operating condition in fail-safe mode	Detected items	Remarks	Reference page
Engine speed will not rise more than 2,500 rpm due to the fuel cut	Malfunction indicator lamp circuit	When there is an open circuit on MIL circuit, the ECM cannot warn the driver by illuminating MIL when there is malfunction on engine control system. Therefore, when electrical controlled throttle and part of ECM related diagnoses are continuously detected as NG for 5 trips, ECM warns the driver that engine control system malfunctions and MIL circuit is open by means of operating the fail-safe function. The fail-safe function also operates when above diagnoses except MIL circuit are detected and demands the driver to repair the malfunction.	EC-456

DTC RELATED ITEM

DTC No.	Detected items	Engine operating condition in fail-safe mode								
P0011 P0021	Intake valve timing control	The signal is not energized to the intake valve timing control solenoid valve and the valve control does not function.								
P0102 P0103	Mass air flow sensor circuit	Engine speed will not rise more than 2,400 rpm due to the fuel cut.								
P0117 P0118	Engine coolant temperature sensor circuit	Engine coolant temperature will be determined by ECM based on the following condition. CONSULT-III displays the engine coolant temperature decided by ECM. <table border="1" style="width: 100%; margin-top: 5px;"> <thead> <tr> <th style="text-align: center;">Condition</th> <th style="text-align: center;">Engine coolant temperature decided (CONSULT-III display)</th> </tr> </thead> <tbody> <tr> <td>Just as ignition switch is turned ON or START</td> <td style="text-align: center;">40°C (104°F)</td> </tr> <tr> <td>Approx 4 minutes or more after engine starting</td> <td style="text-align: center;">80°C (176°F)</td> </tr> <tr> <td>Except as shown above</td> <td style="text-align: center;">40 - 80°C (104 - 176°F) (Depends on the time)</td> </tr> </tbody> </table> <p>When the fail-safe system for engine coolant temperature sensor is activated, the cooling fan operates while engine is running.</p>	Condition	Engine coolant temperature decided (CONSULT-III display)	Just as ignition switch is turned ON or START	40°C (104°F)	Approx 4 minutes or more after engine starting	80°C (176°F)	Except as shown above	40 - 80°C (104 - 176°F) (Depends on the time)
Condition	Engine coolant temperature decided (CONSULT-III display)									
Just as ignition switch is turned ON or START	40°C (104°F)									
Approx 4 minutes or more after engine starting	80°C (176°F)									
Except as shown above	40 - 80°C (104 - 176°F) (Depends on the time)									
P0122 P0123 P0222 P0223 P2135	Throttle position sensor	The ECM controls the electric throttle control actuator in regulating the throttle opening in order for the idle position to be within +10 degrees. The ECM regulates the opening speed of the throttle valve to be slower than the normal condition. Therefore, the acceleration will be poor.								
P0196 P0197 P0198	Engine oil temperature sensor	Intake valve timing control does not function.								
P0500	Vehicle speed sensor	The cooling fan operates (Highest) while engine is running.								
P0605	ECM	(When ECM calculation function is malfunctioning:) ECM stops the electric throttle control actuator control, throttle valve is maintained at a fixed opening (approx. 5 degrees) by the return spring. ECM deactivates ASCD operation.								
P0643	Sensor power supply	ECM stops the electric throttle control actuator control, throttle valve is maintained at a fixed opening (approx. 5 degrees) by the return spring.								
P1805	Brake switch	ECM controls the electric throttle control actuator by regulating the throttle opening to a small range. Therefore, acceleration will be poor. <table border="1" style="width: 100%; margin-top: 5px;"> <thead> <tr> <th style="text-align: center;">Vehicle condition</th> <th style="text-align: center;">Driving condition</th> </tr> </thead> <tbody> <tr> <td>When engine is idling</td> <td style="text-align: center;">Normal</td> </tr> <tr> <td>When accelerating</td> <td style="text-align: center;">Poor acceleration</td> </tr> </tbody> </table>	Vehicle condition	Driving condition	When engine is idling	Normal	When accelerating	Poor acceleration		
Vehicle condition	Driving condition									
When engine is idling	Normal									
When accelerating	Poor acceleration									
P2100 P2103	Throttle control motor relay	ECM stops the electric throttle control actuator control, throttle valve is maintained at a fixed opening (approx. 5 degrees) by the return spring.								
P2101	Electric throttle control function	ECM stops the electric throttle control actuator control, throttle valve is maintained at a fixed opening (approx. 5 degrees) by the return spring.								

ECM

< ECU DIAGNOSIS >

[VQ35DE]

DTC No.	Detected items	Engine operating condition in fail-safe mode
P2118	Throttle control motor	ECM stops the electric throttle control actuator control, throttle valve is maintained at a fixed opening (approx. 5 degrees) by the return spring.
P2119	Electric throttle control actuator	<p>(When electric throttle control actuator does not function properly due to the return spring malfunction:) ECM controls the electric throttle actuator by regulating the throttle opening around the idle position. The engine speed will not rise more than 2,000 rpm.</p> <p>(When throttle valve opening angle in fail-safe mode is not in specified range:) ECM controls the electric throttle control actuator by regulating the throttle opening to 20 degrees or less.</p> <p>(When ECM detects the throttle valve is stuck open:) While the vehicle is being driven, it slows down gradually because of fuel cut. After the vehicle stops, the engine stalls. The engine can restart in the N or P position, and engine speed will not exceed 1,000 rpm or more.</p>
P2122 P2123 P2127 P2128 P2138	Accelerator pedal position sensor	<p>The ECM controls the electric throttle control actuator in regulating the throttle opening in order for the idle position to be within +10 degrees.</p> <p>The ECM regulates the opening speed of the throttle valve to be slower than the normal condition. Therefore, the acceleration will be poor.</p>

A

EC

C

D

E

F

DTC Inspection Priority Chart

INFOID:000000003388288

If some DTCs are displayed at the same time, perform inspections one by one based on the following priority chart.

G

H

I

J

K

L

M

N

O

P

< ECU DIAGNOSIS >

Priority	Detected items (DTC)
1	<ul style="list-style-type: none"> • U0101 U0164 U1000 U1001 CAN communication line • P0101 P0102 P0103 Mass air flow sensor • P0112 P0113 P0127 Intake air temperature sensor • P0116 P0117 P0118 P0125 Engine coolant temperature sensor • P0122 P0123 P0222 P0223 P1225 P1226 P2135 Throttle position sensor • P0128 Thermostat function • P0181 P0182 P0183 Fuel tank temperature sensor • P0196 P0197 P0198 Engine oil temperature sensor • P0327 P0328 P0332 P0333 Knock sensor • P0335 Crankshaft position sensor (POS) • P0340 P0345 Camshaft position sensor (PHASE) • P0460 P0461 P0462 P0463 Fuel level sensor • P0500 Vehicle speed sensor • P0605 P0607 ECM • P0643 Sensor power supply • P0705 P0850 Park/Neutral position (PNP) switch • P1550 P1551 P1552 P1553 P1554 Battery current sensor • P1610 - P1615 NATS • P1700 CVT control system • P2122 P2123 P2127 P2128 P2138 Accelerator pedal position sensor
2	<ul style="list-style-type: none"> • P0031 P0032 P0051 P0052 Air fuel ratio (A/F) sensor 1 heater • P0037 P0038 P0057 P0058 Heated oxygen sensor 2 heater • P0075 P0081 Intake valve timing control solenoid valve • P0130 P0131 P0132 P0133 P0150 P0151 P0152 P0153 P2A00 P2A03 Air fuel ratio (A/F) sensor 1 • P0137 P0138 P0139 P0157 P0158 P0159 Heated oxygen sensor 2 • P0441 EVAP control system purge flow monitoring • P0443 P0444 P0445 EVAP canister purge volume control solenoid valve • P0447 P0448 EVAP canister vent control valve • P0451 P0452 P0453 EVAP control system pressure sensor • P0550 Power steering pressure sensor • P0603 ECM power supply • P0710 P0715 P0720 P0740 P0744 P0745 P0746 P0776 P0778 P0840 P0845 P1740 CVT related sensors, solenoid valves and switches • P1217 Engine over temperature (OVERHEAT) • P1720 Vehicle speed sensor • P1777 P1778 CVT step motor • P1800 P1801 VIAS control solenoid valve • P1805 Brake switch • P2100 P2103 Throttle control motor relay • P2101 Electric throttle control function • P2118 Throttle control motor
3	<ul style="list-style-type: none"> • P0011 P0021 Intake valve timing control • P0171 P0172 P0174 P0175 Fuel injection system function • P0300 - P0306 Misfire • P0420 P0430 Three way catalyst function • P0442 P0456 EVAP control system (SMALL LEAK, VERY SMALL LEAK) • P0455 EVAP control system (GROSS LEAK) • P0506 P0507 Idle speed control system • P1148 P1168 Closed loop control • P1212 TCS communication line • P1421 Cold start control • P1564 ASCD steering switch • P1572 ASCD brake switch • P1574 ASCD vehicle speed sensor • P1715 Primary speed sensor • P2119 Electric throttle control actuator

DTC Index

x:Applicable —: Not applicable

DTC*1		Items (CONSULT-III screen terms)	SRT code	Trip	MIL	Reference page
CONSULT-III GST*2	ECM*3					
U0101	0101*4	LOST COMM (ECM)	—	1	×	EC-138
U0164	0164*4	LOST COMM (HVAC)	—	1	×	EC-139
U1000	1000*4	CAN COMM CIRCUIT	—	1	×	EC-140
U1001	1001*4	CAN COMM CIRCUIT	—	2	—	EC-140
P0000	0000	NO DTC IS DETECTED. FURTHER TESTING MAY BE REQUIRED.	—	—	Blinking*7	—
P0011	0011	INT/V TIM CONT-B1	—	2	×	EC-141
P0021	0021	INT/V TIM CONT-B2	—	2	×	EC-141
P0031	0031	A/F SEN1 HTR (B1)	—	2	×	EC-145
P0032	0032	A/F SEN1 HTR (B1)	—	2	×	EC-145
P0037	0037	HO2S2 HTR (B1)	—	2	×	EC-148
P0038	0038	HO2S2 HTR (B1)	—	2	×	EC-148
P0051	0051	A/F SEN1 HTR (B2)	—	2	×	EC-145
P0052	0052	A/F SEN1 HTR (B2)	—	2	×	EC-145
P0057	0057	HO2S2 HTR (B2)	—	2	×	EC-148
P0058	0058	HO2S2 HTR (B2)	—	2	×	EC-148
P0075	0075	INT/V TIM V/CIR-B1	—	2	×	EC-151
P0081	0081	INT/V TIM V/CIR-B2	—	2	×	EC-151
P0101	0101	MAF SEN/CIRCUIT-B1	—	2	×	EC-154
P0102	0102	MAF SEN/CIRCUIT-B1	—	1	×	EC-162
P0103	0103	MAF SEN/CIRCUIT-B1	—	1	×	EC-162
P0112	0112	IAT SEN/CIRCUIT-B1	—	2	×	EC-167
P0113	0113	IAT SEN/CIRCUIT-B1	—	2	×	EC-167
P0116	0116	ECT SEN/CIRC	—	2	×	EC-170
P0117	0117	ECT SEN/CIRC	—	1	×	EC-172
P0118	0118	ECT SEN/CIRC	—	1	×	EC-172
P0122	0122	TP SEN 2/CIRC-B1	—	1	×	EC-175
P0123	0123	TP SEN 2/CIRC-B1	—	1	×	EC-175
P0125	0125	ECT SENSOR	—	2	×	EC-178
P0127	0127	IAT SENSOR-B1	—	2	×	EC-181
P0128	0128	THERMSTAT FNCTN	—	2	×	EC-183
P0130	0130	A/F SENSOR1 (B1)	—	2	×	EC-186
P0131	0131	A/F SENSOR1 (B1)	—	2	×	EC-190
P0132	0132	A/F SENSOR1 (B1)	—	2	×	EC-194
P0133	0133	A/F SENSOR1 (B1)	×	2	×	EC-198
P0137	0137	HO2S2 (B1)	×	2	×	EC-203
P0138	0138	HO2S2 (B1)	×	2	×	EC-210
P0139	0139	HO2S2 (B1)	×	2	×	EC-219
P0150	0150	A/F SENSOR1 (B2)	—	2	×	EC-186

ECM

< ECU DIAGNOSIS >

[VQ35DE]

DTC*1		Items (CONSULT-III screen terms)	SRT code	Trip	MIL	Reference page
CONSULT-III GST*2	ECM*3					
P0151	0151	A/F SENSOR1 (B2)	—	2	×	EC-190
P0152	0152	A/F SENSOR1 (B2)	—	2	×	EC-194
P0153	0153	A/F SENSOR1 (B2)	×	2	×	EC-198
P0157	0157	HO2S2 (B2)	×	2	×	EC-203
P0158	0158	HO2S2 (B2)	×	2	×	EC-210
P0159	0159	HO2S2 (B2)	×	2	×	EC-219
P0171	0171	FUEL SYS-LEAN-B1	—	2	×	EC-226
P0172	0172	FUEL SYS-RICH-B1	—	2	×	EC-231
P0174	0174	FUEL SYS-LEAN-B2	—	2	×	EC-226
P0175	0175	FUEL SYS-RICH-B2	—	2	×	EC-231
P0181	0181	FTT SENSOR	—	2	×	EC-236
P0182	0182	FTT SEN/CIRCUIT	—	2	×	EC-239
P0183	0183	FTT SEN/CIRCUIT	—	2	×	EC-239
P0196	0196	EOT SEN/CIRC	—	2	×	EC-242
P0197	0197	EOT SEN/CIRC	—	2	×	EC-245
P0198	0198	EOT SEN/CIRC	—	2	×	EC-245
P0222	0222	TP SEN 1/CIRC-B1	—	1	×	EC-248
P0223	0223	TP SEN 1/CIRC-B1	—	1	×	EC-248
P0300	0300	MULTI CYL MISFIRE	—	1 or 2	×	EC-251
P0301	0301	CYL 1 MISFIRE	—	1 or 2	×	EC-251
P0302	0302	CYL 2 MISFIRE	—	1 or 2	×	EC-251
P0303	0303	CYL 3 MISFIRE	—	1 or 2	×	EC-251
P0304	0304	CYL 4 MISFIRE	—	1 or 2	×	EC-251
P0305	0305	CYL 5 MISFIRE	—	1 or 2	×	EC-251
P0306	0306	CYL 6 MISFIRE	—	1 or 2	×	EC-251
P0327	0327	KNOCK SEN/CIRC-B1	—	2	—	EC-257
P0328	0328	KNOCK SEN/CIRC-B1	—	2	—	EC-257
P0332	0332	KNOCK SEN/CIRC-B2	—	2	—	EC-257
P0333	0333	KNOCK SEN/CIRC-B2	—	2	—	EC-257
P0335	0335	CKP SEN/CIRCUIT	—	2	×	EC-260
P0340	0340	CMP SEN/CIRC-B1	—	2	×	EC-264
P0345	0345	CMP SEN/CIRC-B2	—	2	×	EC-264
P0420	0420	TW CATALYST SYS-B1	×	2	×	EC-268
P0430	0430	TW CATALYST SYS-B2	×	2	×	EC-268
P0441	0441	EVAP PURG FLOW/MON	×	2	×	EC-273
P0442	0442	EVAP SMALL LEAK	×	2	×	EC-278
P0443	0443	PURG VOLUME CONT/V	—	2	×	EC-284
P0444	0444	PURG VOLUME CONT/V	—	2	×	EC-289
P0445	0445	PURG VOLUME CONT/V	—	2	×	EC-289
P0447	0447	VENT CONTROL VALVE	—	2	×	EC-292
P0448	0448	VENT CONTROL VALVE	—	2	×	EC-296
P0451	0451	EVAP SYS PRES SEN	—	2	×	EC-300

ECM

< ECU DIAGNOSIS >

[VQ35DE]

DTC*1		Items (CONSULT-III screen terms)	SRT code	Trip	MIL	Reference page
CONSULT-III GST*2	ECM*3					
P0452	0452	EVAP SYS PRES SEN	—	2	×	EC-303
P0453	0453	EVAP SYS PRES SEN	—	2	×	EC-308
P0455	0455	EVAP GROSS LEAK	—	2	×	EC-314
P0456	0456	EVAP VERY SML LEAK	×*6	2	×	EC-320
P0460	0460	FUEL LEV SEN SLOSH	—	2	×	EC-327
P0461	0461	FUEL LEVEL SENSOR	—	2	×	EC-329
P0462	0462	FUEL LEVL SEN/CIRC	—	2	×	EC-331
P0463	0463	FUEL LEVL SEN/CIRC	—	2	×	EC-331
P0500	0500	VEH SPEED SEN/CIRC*5	—	2	×	EC-333
P0506	0506	ISC SYSTEM	—	2	×	EC-335
P0507	0507	ISC SYSTEM	—	2	×	EC-337
P0550	0550	PW ST P SEN/CIRC	—	2	—	EC-339
P0603	0603	ECM BACK UP/CIRCUIT	—	2	×	EC-342
P0605	0605	ECM	—	1 or 2	× or —	EC-344
P0607	0607	ECM	—	1	×	EC-346
P0643	0643	SENSOR POWER/CIRC	—	1	×	EC-347
P0705	0705	PNP SW/CIRC	—	2	×	TM-44
P0710	0710	ATF TEMP SEN/CIRC*8	—	1	×	TM-47
P0715	0715	INPUT SPD SEN/CIRC	—	2	×	TM-50
P0720	0720	VEH SPD SEN/CIR AT*5	—	2	×	TM-53
P0740	0740	TCC SOLENOID/CIRC	—	2	×	TM-60
P0744	0744	A/T TCC S/V FNCTN	—	2	×	TM-62
P0745	0745	L/PRESS SOL/CIRC	—	2	×	TM-64
P0746	0746	PRS CNT SOL/A FCTN	—	1	×	TM-66
P0776	0776	PRS CNT SOL/B FCTN	—	2	×	TM-68
P0778	0778	PRS CNT SOL/B CIRC	—	2	×	TM-70
P0840	0840	TR PRS SENS/A CIRC	—	2	×	TM-72
P0845	0845	TR PRS SENS/B CIRC	—	2	×	TM-78
P0850	0850	P-N POS SW/CIRCUIT	—	2	×	EC-350
P1148	1148	CLOSED LOOP-B1	—	1	×	EC-353
P1168	1168	CLOSED LOOP-B2	—	1	×	EC-353
P1212	1212	TCS/CIRC	—	2	—	EC-354
P1217	1217	ENG OVER TEMP	—	1	×	EC-355
P1225	1225	CTP LEARNING-B1	—	2	—	EC-359
P1226	1226	CTP LEARNING-B1	—	2	—	EC-361
P1421	1421	COLD START CONTROL	—	2	×	EC-363
P1550	1550	BAT CURRENT SENSOR	—	2	—	EC-365
P1551	1551	BAT CURRENT SENSOR	—	2	—	EC-368
P1552	1552	BAT CURRENT SENSOR	—	2	—	EC-368
P1553	1553	BAT CURRENT SENSOR	—	2	—	EC-371
P1554	1554	BAT CURRENT SENSOR	—	2	—	EC-374
P1564	1564	ASCD SW	—	1	—	EC-377

A

EC

C

D

E

F

G

H

I

J

K

L

M

N

O

P

DTC*1		Items (CONSULT-III screen terms)	SRT code	Trip	MIL	Reference page
CONSULT-III GST*2	ECM*3					
P1572	1572	ASCD BRAKE SW	—	1	—	EC-380
P1574	1574	ASCD VHL SPD SEN	—	1	—	EC-386
P1610	1610	LOCK MODE	—	2	—	SEC-39 or SEC-269
P1611	1611	ID DISCORD, IMM-ECM	—	2	—	SEC-40 or SEC-270
P1612	1612	CHAIN OF ECM-IMMU	—	2	—	SEC-42 or SEC-272
P1614	1614	CHAIN OF IMMU-KEY	—	2	—	SEC-43 or SEC-273
P1615	1615	DIFFERENCE OF KEY	—	2	—	SEC-46 or SEC-276
P1700	1700	CVT C/U FUNCT	—	1	—	EC-388
P1715	1715	IN PULY SPEED	—	2	—	EC-389
P1720	1720	V/SP SEN(A/T OUT)	—	2	—	EC-391
P1740	1740	LU-SLCT SOL/CIRC	—	2	×	TM-92
P1777	1777	STEP MOTR CIRC	—	1	×	TM-95
P1778	1778	STEP MOTR FNC	—	2	×	TM-98
P1800	1800	VIAS S/V-1	—	2	—	EC-393
P1801	1801	VIAS S/V-2	—	2	—	EC-396
P1805	1805	BRAKE SW/CIRCUIT	—	2	—	EC-399
P2100	2100	ETC MOT PWR-B1	—	1	×	EC-402
P2101	2101	ETC FNCTN/CIRC-B1	—	1	×	EC-404
P2103	2103	ETC MOT PWR	—	1	×	EC-402
P2118	2118	ETC MOT-B1	—	1	×	EC-408
P2119	2119	ETC ACTR-B1	—	1	×	EC-411
P2122	2122	APP SEN 1/CIRC	—	1	×	EC-413
P2123	2123	APP SEN 1/CIRC	—	1	×	EC-413
P2127	2127	APP SEN 2/CIRC	—	1	×	EC-416
P2128	2128	APP SEN 2/CIRC	—	1	×	EC-416
P2135	2135	TP SENSOR-B1	—	1	×	EC-420
P2138	2138	APP SENSOR	—	1	×	EC-423
P2A00	2A00	A/F SENSOR1 (B1)	—	2	×	EC-427
P2A03	2A03	A/F SENSOR1 (B2)	—	2	×	EC-427

*1: 1st trip DTC No. is the same as DTC No.

*2: This number is prescribed by SAE J2012.

*3: In Diagnostic Test Mode II (Self-diagnostic results), this number is controlled by NISSAN.

*4: The troubleshooting for this DTC needs CONSULT-III.

*5: When the fail-safe operations for both self-diagnoses occur, the MIL illuminates.

*6: SRT code will not be set if the self-diagnostic result is NG.

*7: When the ECM is in the mode displays SRT status, MIL may blink. For the details, refer to "How to Display SRT Status".

*8: When erasing this DTC, always use CONSULT-III or GST.

How to Set SRT Code

INFOID:000000003388290

To set all SRT codes, self-diagnoses for the items indicated above must be performed one or more times. Each diagnosis may require a long period of actual driving under various conditions.

WITH CONSULT-III

Perform corresponding DTC Confirmation Procedure one by one based on Performance Priority in the table on "SRT Item".

WITHOUT CONSULT-III

The most efficient driving pattern in which SRT codes can be properly set is explained on the next page. The driving pattern should be performed one or more times to set all SRT codes.

DRIVING PATTERN

Note: Always drive vehicle in safe manner according to traffic conditions and obey all traffic laws. Refer to next page for more information and explanation of chart.

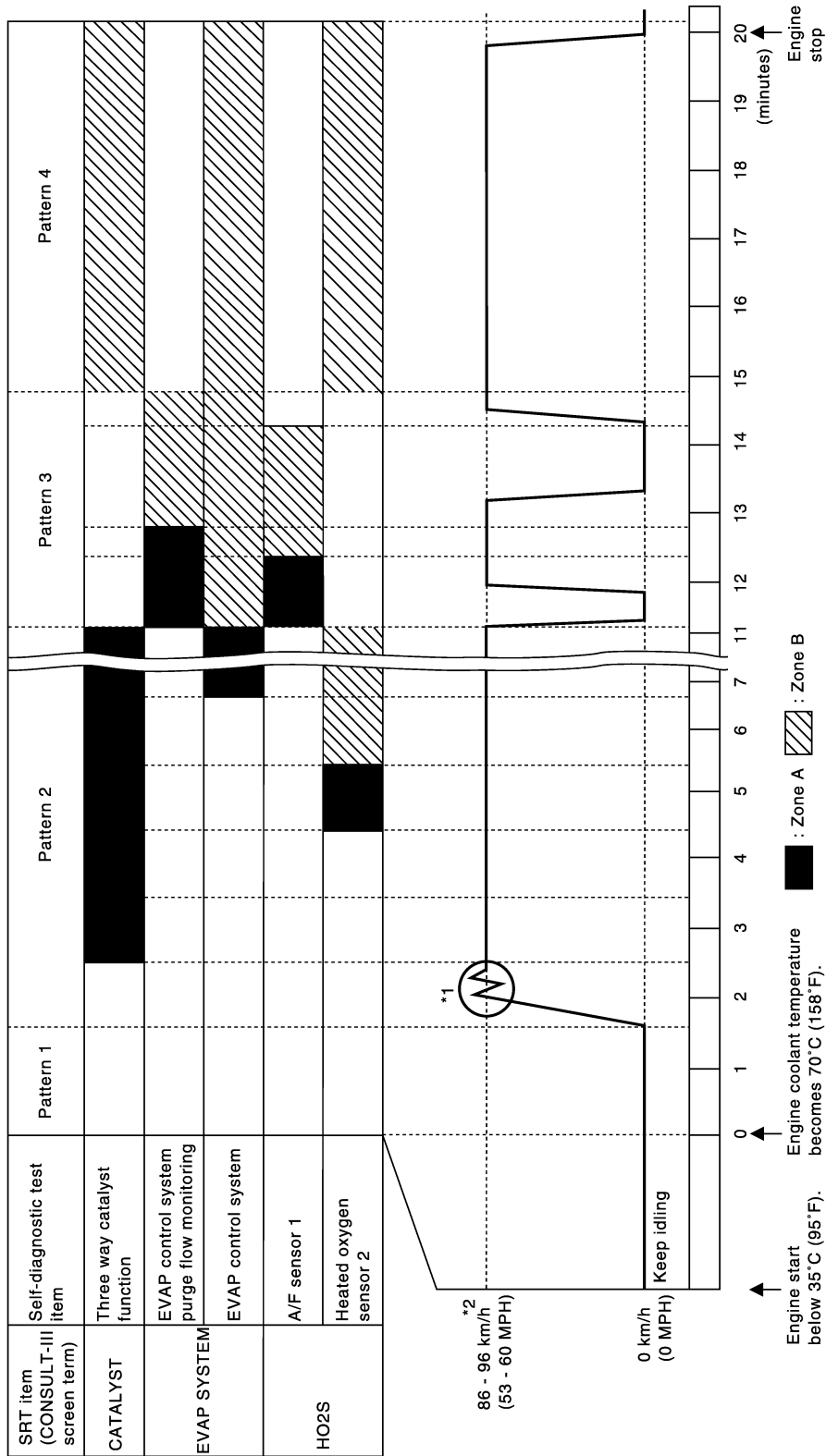

PBIB3622E

A
EC
C
D
E
F
G
H
I
J
K
L
M
N
O
P

< ECU DIAGNOSIS >

- The time required for each diagnosis varies with road surface conditions, weather, altitude, individual driving habits, etc.

Zone A refers to the range where the time, required for the diagnosis under normal conditions*, is the shortest.

Zone B refers to the range where the diagnosis can still be performed if the diagnosis is not completed within zone A.

*: Normal conditions refer to the following:

- Sea level
 - Flat road
 - Ambient air temperature: 20 - 30°C (68 - 86°F)
 - Diagnosis is performed as quickly as possible under normal conditions.
- Under different conditions [For example: ambient air temperature other than 20 - 30°C (68 - 86°F)], diagnosis may also be performed.

Pattern 1:

- The engine is started at the engine coolant temperature of -10 to 35°C (14 to 95°F) (where the voltage between the ECM terminal 46 and ground is 3.0 - 4.3 V).**
- The engine must be operated at idle speed until the engine coolant temperature is greater than 70°C (158°F) (where the voltage between the ECM terminal 46 and ground is lower than 1.4 V).**
- The engine is started at the fuel tank temperature of warmer than 0°C (32°F) (where the voltage between the ECM terminal 95 and ground is less than 4.1 V).**

Pattern 2:

- When steady-state driving is performed again even after it is interrupted, each diagnosis can be conducted. In this case, the time required for diagnosis may be extended.

Pattern 3:

- Operate vehicle following the driving pattern shown in the figure.
- Release the accelerator pedal during deceleration of vehicle speed from 90 km/h (56 MPH) to 0 km/h (0 MPH).

Pattern 4:

- The accelerator pedal must be held very steady during steady-state driving.
- If the accelerator pedal is moved, the test must be conducted again.

*1: Depress the accelerator pedal until vehicle speed is 90 km/h (56 MPH), then release the accelerator pedal and keep it released for more than 10 seconds. Depress the accelerator pedal until vehicle speed is 90 km/h (56 MPH) again.

*2: Checking the vehicle speed with GST is advised.

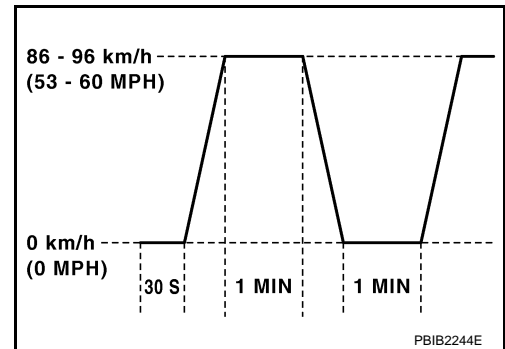

Suggested Transmission Gear Position for CVT Models
Set the selector lever in the D position.

Test Value and Test Limit

INFOID:000000004747837

The following is the information specified in Service \$06 of SAE J1979.

The test value is a parameter used to determine whether a system/circuit diagnostic test is OK or NG while being monitored by the ECM during self-diagnosis. The test limit is a reference value which is specified as the maximum or minimum value and is compared with the test value being monitored.

These data (test value and test limit) are specified by On Board Monitor ID(OBDMID), Test ID (TID), Unit and Scaling ID and can be displayed on the GST screen.

The items of the test value and test limit will be displayed with GST screen which items are provided by the ECM. (eg., if bank 2 is not applied on this vehicle, only the items of bank 1 are displayed)

ECM

< ECU DIAGNOSIS >

[VQ35DE]

Item	OBD-MID	Self-diagnostic test item	DTC	Test value and Test limit (GST display)		Description
				TID	Unit and Scaling ID	
HO2S	01H	Air fuel ratio (A/F) sensor 1 (Bank 1)	P0131	83H	0BH	Minimum sensor output voltage for test cycle
			P0131	84H	0BH	Maximum sensor output voltage for test cycle
			P0130	85H	0BH	Minimum sensor output voltage for test cycle
			P0130	86H	0BH	Maximum sensor output voltage for test cycle
			P0133	87H	04H	Response rate: Response ratio (Lean to Rich)
			P0133	88H	04H	Response rate: Response ratio (Rich to Lean)
			P2A00	89H	84H	The amount of shift in air fuel ratio
			P2A00	8AH	84H	The amount of shift in air fuel ratio
			P0130	8BH	0BH	Difference in sensor output voltage
			P0133	8CH	83H	Response gain at the limited frequency
	02H	Heated oxygen sensor 2 (Bank 1)	P0138	07H	0CH	Minimum sensor output voltage for test cycle
			P0137	08H	0CH	Maximum sensor output voltage for test cycle
			P0138	80H	0CH	Sensor output voltage
			P0139	81H	0CH	Difference in sensor output voltage
03H	Heated oxygen sensor 3 (Bank 1)	P0143	07H	0CH	Minimum sensor output voltage for test cycle	
		P0144	08H	0CH	Maximum sensor output voltage for test cycle	
		P0146	80H	0CH	Sensor output voltage	
		P0145	81H	0CH	Difference in sensor output voltage	

A
EC
C
D
E
F
G
H
I
J
K
L
M
N
O
P

ECM

< ECU DIAGNOSIS >

[VQ35DE]

Item	OBD-MID	Self-diagnostic test item	DTC	Test value and Test limit (GST display)		Description
				TID	Unit and Scaling ID	
HO2S	05H	Air fuel ratio (A/F) sensor 1 (Bank 2)	P0151	83H	0BH	Minimum sensor output voltage for test cycle
			P0151	84H	0BH	Maximum sensor output voltage for test cycle
			P0150	85H	0BH	Minimum sensor output voltage for test cycle
			P0150	86H	0BH	Maximum sensor output voltage for test cycle
			P0153	87H	04H	Response rate: Response ratio (Lean to Rich)
			P0153	88H	04H	Response rate: Response ratio (Rich to Lean)
			P2A03	89H	84H	The amount of shift in air fuel ratio
			P2A03	8AH	84H	The amount of shift in air fuel ratio
			P0150	8BH	0BH	Difference in sensor output voltage
			P0153	8CH	83H	Response gain at the limited frequency
	06H	Heated oxygen sensor 2 (Bank 2)	P0158	07H	0CH	Minimum sensor output voltage for test cycle
			P0157	08H	0CH	Maximum sensor output voltage for test cycle
			P0158	80H	0CH	Sensor output voltage
			P0159	81H	0CH	Difference in sensor output voltage
07H	Heated oxygen sensor 3 (Bank2)	P0163	07H	0CH	Minimum sensor output voltage for test cycle	
		P0164	08H	0CH	Maximum sensor output voltage for test cycle	
		P0166	80H	0CH	Sensor output voltage	
		P0165	81H	0CH	Difference in sensor output voltage	
CATA- LYST	21H	Three way catalyst function (Bank1)	P0420	80H	01H	O2 storage index
			P0420	82H	01H	Switching time lag engine exhaust index value
			P2423	83H	0CH	Difference in 3rd O2 sensor output voltage
			P2423	84H	84H	O2 storage index in HC trap catalyst
	22H	Three way catalyst function (Bank2)	P0430	80H	01H	O2 storage index
			P0430	82H	01H	Switching time lag engine exhaust index value
			P2424	83H	0CH	Difference in 3rd O2 sensor output voltage
			P2424	84H	84H	O2 storage index in HC trap catalyst

ECM

< ECU DIAGNOSIS >

[VQ35DE]

Item	OBD-MID	Self-diagnostic test item	DTC	Test value and Test limit (GST display)		Description
				TID	Unit and Scaling ID	
EGR SYSTEM	31H	EGR function	P0400	80H	96H	Low Flow Faults: EGR temp change rate (short term)
			P0400	81H	96H	Low Flow Faults: EGR temp change rate (long term)
			P0400	82H	96H	Low Flow Faults: Difference between max EGR temp and EGR temp under idling condition
			P0400	83H	96H	Low Flow Faults: Max EGR temp
			P1402	84H	96H	High Flow Faults: EGR temp increase rate
VVT SYSTEM	35H	VVT Monitor (Bank1)	P0011	80H	9DH	VTC intake function diagnosis (VTC alignment check diagnosis)
			P0014	81H	9DH	VTC exhaust function diagnosis (VTC alignment check diagnosis)
			P0011	82H	9DH	VTC intake function diagnosis (VTC drive failure diagnosis)
			P0014	83H	9DH	VTC exhaust function diagnosis (VTC drive failure diagnosis)
	36H	VVT Monitor (Bank2)	P0021	80H	9DH	VTC intake function diagnosis (VTC alignment check diagnosis)
			P0024	81H	9DH	VTC exhaust function diagnosis (VTC alignment check diagnosis)
			P0021	82H	9DH	VTC intake function diagnosis (VTC drive failure diagnosis)
			P0024	83H	9DH	VTC exhaust function diagnosis (VTC drive failure diagnosis)
EVAP SYSTEM	39H	EVAP control system leak (Cap Off)	P0455	80H	0CH	Difference in pressure sensor output voltage before and after pull down
	3BH	EVAP control system leak (Small leak)	P0442	80H	05H	Leak area index (for more than 0.04 inch)
	3CH	EVAP control system leak (Very small leak)	P0456	80H	05H	Leak area index (for more than 0.02 inch)
			P0456	81H	FDH	Maximum internal pressure of EVAP system during monitoring
	3DH	Purge flow system	P0441	83H	0CH	Difference in pressure sensor output voltage before and after vent control valve close
O2 SENSOR HEATER	41H	A/F sensor 1 heater (Bank 1)	Low Input:P0031 High Input:P0032	81H	0BH	Converted value of Heater electric current to voltage
	42H	Heated oxygen sensor 2 heater (Bank 1)	Low Input:P0037 High Input:P0038	80H	0CH	Converted value of Heater electric current to voltage
	43H	Heated oxygen sensor 3 heater (Bank 1)	P0043	80H	0CH	Converted value of Heater electric current to voltage
	45H	A/F sensor 1 heater (Bank 2)	Low Input:P0051 High Input:P0052	81H	0BH	Converted value of Heater electric current to voltage
	46H	Heated oxygen sensor 2 heater (Bank 2)	Low Input:P0057 High Input:P0058	80H	0CH	Converted value of Heater electric current to voltage
	47H	Heated oxygen sensor 3 heater (Bank 2)	P0063	80H	0CH	Converted value of Heater electric current to voltage

A

EC

C

D

E

F

G

H

I

J

K

L

M

N

O

P

ECM

< ECU DIAGNOSIS >

[VQ35DE]

Item	OBD-MID	Self-diagnostic test item	DTC	Test value and Test limit (GST display)		Description
				TID	Unit and Scaling ID	
SEC- OND- ARY AIR	71H	Secondary Air system	P0411	80H	01H	Secondary Air Injection System Incorrect Flow Detected
			Bank1: P0491 Bank2: P0492	81H	01H	Secondary Air Injection System Insufficient Flow
			P2445	82H	01H	Secondary Air Injection System Pump Stuck Off
			P2448	83H	01H	Secondary Air Injection System High Airflow
			Bank1: P2440 Bank2: P2442	84H	01H	Secondary Air Injection System Switching Valve Stuck Open
			P2440	85H	01H	Secondary Air Injection System Switching Valve Stuck Open
			P2444	86H	01H	Secondary Air Injection System Pump Stuck On
FUEL SYSTEM	81H	Fuel injection system function (Bank 1)	P0171 or P0172	80H	2FH	Long term fuel trim
			P0171 or P0172	81H	24H	The number of lambda control clamped
	82H	Fuel injection system function (Bank 2)	P0174 or P0175	80H	2FH	Long term fuel trim
			P0174 or P0175	81H	24H	The number of lambda control clamped

ECM

< ECU DIAGNOSIS >

[VQ35DE]

Item	OBD-MID	Self-diagnostic test item	DTC	Test value and Test limit (GST display)		Description
				TID	Unit and Scaling ID	
MISFIRE	A1H	Multiple Cylinder Misfires	P0301	80H	24H	Misfiring counter at 1000 revolution of the first cylinder
			P0302	81H	24H	Misfiring counter at 1000 revolution of the second cylinder
			P0303	82H	24H	Misfiring counter at 1000 revolution of the third cylinder
			P0304	83H	24H	Misfiring counter at 1000 revolution of the fourth cylinder
			P0305	84H	24H	Misfiring counter at 1000 revolution of the fifth cylinder
			P0306	85H	24H	Misfiring counter at 1000 revolution of the sixth cylinder
			P0307	86H	24H	Misfiring counter at 1000 revolution of the seventh cylinder
			P0308	87H	24H	Misfiring counter at 1000 revolution of the eighth cylinder
			P0300	88H	24H	Misfiring counter at 1000 revolution of the multiple cylinders
			P0301	89H	24H	Misfiring counter at 200 revolution of the first cylinder
			P0302	8AH	24H	Misfiring counter at 200 revolution of the second cylinder
			P0303	8BH	24H	Misfiring counter at 200 revolution of the third cylinder
			P0304	8CH	24H	Misfiring counter at 200 revolution of the fourth cylinder
			P0305	8DH	24H	Misfiring counter at 200 revolution of the fifth cylinder
			P0306	8EH	24H	Misfiring counter at 200 revolution of the sixth cylinder
			P0307	8FH	24H	Misfiring counter at 200 revolution of the seventh cylinder
			P0308	90H	24H	Misfiring counter at 200 revolution of the eighth cylinder
			P0300	91H	24H	Misfiring counter at 1000 revolution of the single cylinder
			P0300	92H	24H	Misfiring counter at 200 revolution of the single cylinder
			P0300	93H	24H	Misfiring counter at 200 revolution of the multiple cylinders

A
EC
C
D
E
F
G
H
I
J
K
L
M
N
O
P

ECM

< ECU DIAGNOSIS >

[VQ35DE]

Item	OBD-MID	Self-diagnostic test item	DTC	Test value and Test limit (GST display)		Description
				TID	Unit and Scaling ID	
MISFIRE	A2H	No. 1 Cylinder Misfire	P0301	0BH	24H	EWMA (Exponential Weighted Moving Average) misfire counts for last 10 driving cycles
			P0301	0CH	24H	Misfire counts for last/current driving cycles
	A3H	No. 2 Cylinder Misfire	P0302	0BH	24H	EWMA (Exponential Weighted Moving Average) misfire counts for last 10 driving cycles
			P0302	0CH	24H	Misfire counts for last/current driving cycles
	A4H	No. 3 Cylinder Misfire	P0303	0BH	24H	EWMA (Exponential Weighted Moving Average) misfire counts for last 10 driving cycles
			P0303	0CH	24H	Misfire counts for last/current driving cycles
	A5H	No. 4 Cylinder Misfire	P0304	0BH	24H	EWMA (Exponential Weighted Moving Average) misfire counts for last 10 driving cycles
			P0304	0CH	24H	Misfire counts for last/current driving cycles
	A6H	No. 5 Cylinder Misfire	P0305	0BH	24H	EWMA (Exponential Weighted Moving Average) misfire counts for last 10 driving cycles
			P0305	0CH	24H	Misfire counts for last/current driving cycles
	A7H	No. 6 Cylinder Misfire	P0306	0BH	24H	EWMA (Exponential Weighted Moving Average) misfire counts for last 10 driving cycles
			P0306	0CH	24H	Misfire counts for last/current driving cycles
	A8H	No. 7 Cylinder Misfire	P0307	0BH	24H	EWMA (Exponential Weighted Moving Average) misfire counts for last 10 driving cycles
			P0307	0CH	24H	Misfire counts for last/current driving cycles
	A9H	No. 8 Cylinder Misfire	P0308	0BH	24H	EWMA (Exponential Weighted Moving Average) misfire counts for last 10 driving cycles
			P0308	0CH	24H	Misfire counts for last/current driving cycles

ENGINE CONTROL SYSTEM SYMPTOMS

< SYMPTOM DIAGNOSIS >

[VQ35DE]

SYMPTOM DIAGNOSIS

ENGINE CONTROL SYSTEM SYMPTOMS

Symptom Table

INFOID:000000003388292

SYSTEM — BASIC ENGINE CONTROL SYSTEM

		SYMPTOM												Reference page	
		HARD/NO START/RESTART (EXCP. HA)	ENGINE STALL	HESITATION/SURGING/FLAT SPOT	SPARK KNOCK/DETONATION	LACK OF POWER/POOR ACCELERATION	HIGH IDLE/LOW IDLE	ROUGH IDLE/HUNTING	IDLING VIBRATION	SLOW/NO RETURN TO IDLE	OVERHEATS/WATER TEMPERATURE HIGH	EXCESSIVE FUEL CONSUMPTION	EXCESSIVE OIL CONSUMPTION		BATTERY DEAD (UNDER CHARGE)
Warranty symptom code		AA	AB	AC	AD	AE	AF	AG	AH	AJ	AK	AL	AM	HA	
Fuel	Fuel pump circuit	1	1	2	3	2		2	2			3		2	EC-447
	Fuel pressure regulator system	3	3	4	4	4	4	4	4	4		4			EC-545
	Fuel injector circuit	1	1	2	3	2		2	2			2			EC-444
	Evaporative emission system	3	3	4	4	4	4	4	4	4	4	4			EC-77
Air	Positive crankcase ventilation system	3	3	4	4	4	4	4	4	4	4	4	1		EC-462
	Incorrect idle speed adjustment						1	1	1	1		1			EC-12
	Electric throttle control actuator	1	1	2	3	3	2	2	2	2		2		2	EC-404 , EC-411
Ignition	Incorrect ignition timing adjustment	3	3	1	1	1		1	1			1			EC-12
	Ignition circuit	1	1	2	2	2		2	2			2			EC-451
Power supply and ground circuit		2	2	3	3	3		3	3		2	3			EC-135
Mass air flow sensor circuit		1			2										EC-154 , EC-162
Engine coolant temperature sensor circuit					3										
Air fuel ratio (A/F) sensor 1 circuit			1	2	3	2		2	2			2			EC-186 , EC-190 , EC-194 , EC-198 , EC-427
Throttle position sensor circuit							2			2					EC-175 , EC-248 , EC-359 , EC-361 , EC-420
Accelerator pedal position sensor circuit				3	2	1									EC-347 , EC-413 , EC-416 , EC-423

ENGINE CONTROL SYSTEM SYMPTOMS

< SYMPTOM DIAGNOSIS >

[VQ35DE]

	SYMPTOM													Reference page
	HARD/NO START/RESTART (EXCP. HA)	ENGINE STALL	HESITATION/SURGING/FLAT SPOT	SPARK KNOCK/DETONATION	LACK OF POWER/POOR ACCELERATION	HIGH IDLE/LOW IDLE	ROUGH IDLE/HUNTING	IDLING VIBRATION	SLOW/NO RETURN TO IDLE	OVERHEATS/WATER TEMPERATURE HIGH	EXCESSIVE FUEL CONSUMPTION	EXCESSIVE OIL CONSUMPTION	BATTERY DEAD (UNDER CHARGE)	
Warranty symptom code	AA	AB	AC	AD	AE	AF	AG	AH	AJ	AK	AL	AM	HA	
Knock sensor circuit			2								3			EC-257
Engine oil temperature sensor			4		2						3			EC-242 , EC-219
Crankshaft position sensor (POS) circuit	2	2												EC-260
Camshaft position sensor (PHASE) circuit	3	2												EC-264
Vehicle speed signal circuit		2	3		3						3			EC-333
Power steering pressure sensor circuit		2					3	3						EC-339
ECM	2	2	3	3	3	3	3	3	3	3	3			EC-342 , EC-344
Intake valve timing control solenoid valve circuit		3	2		1	3	2	2	3		3			EC-151
PNP signal circuit			3		3		3	3			3			EC-350
VIAS control solenoid valve 1 circuit					1									EC-393
VIAS control solenoid valve 2 circuit					1									EC-396
Refrigerant pressure sensor circuit		2				3			3		4			EC-463
Electrical load signal circuit							3							EC-439
Air conditioner circuit	2	2	3	3	3	3	3	3	3		3		2	HAC-38 , HAC-157
ABS actuator and electric unit (control unit)			4											BRC-29

1 - 6: The numbers refer to the order of inspection.

(continued on next page)

SYSTEM — ENGINE MECHANICAL & OTHER

ENGINE CONTROL SYSTEM SYMPTOMS

< SYMPTOM DIAGNOSIS >

[VQ35DE]

		SYMPTOM												Reference page	
		HARD/NO START/RESTART (EXCP. HA)	ENGINE STALL	HESITATION/SURGING/FLAT SPOT	SPARK KNOCK/DETONATION	LACK OF POWER/POOR ACCELERATION	HIGH IDLE/LOW IDLE	ROUGH IDLE/HUNTING	IDLING VIBRATION	SLOW/NO RETURN TO IDLE	OVERHEATS/WATER TEMPERATURE HIGH	EXCESSIVE FUEL CONSUMPTION	EXCESSIVE OIL CONSUMPTION		BATTERY DEAD (UNDER CHARGE)
Warranty symptom code		AA	AB	AC	AD	AE	AF	AG	AH	AJ	AK	AL	AM	HA	
Fuel	Fuel tank	5													FL-12
	Fuel piping			5	5	5		5	5			5			FL-4
	Vapor lock		5												—
	Valve deposit														—
	Poor fuel (Heavy weight gasoline, Low octane)	5		5	5	5		5	5			5			—
Air	Air duct														EM-27
	Air cleaner														EM-27
	Air leakage from air duct (Mass air flow sensor — electric throttle control actuator)		5	5		5		5	5			5			EM-27
	Electric throttle control actuator	5			5		5			5					EM-29
	Air leakage from intake manifold/Collector/Gasket														EM-29 , EM-32
Cranking	Battery	1	1	1		1		1	1					1	PG-106
	Generator circuit														CHG-21
	Starter circuit	3										1			STR-5
	Signal plate	6													EM-114
	PNP signal	4													TM-45
Engine	Cylinder head														EM-107
	Cylinder head gasket	5	5	5	5	5		5	5		4	5	3		
	Cylinder block														EM-118
	Piston												4		
	Piston ring														
	Connecting rod	6	6	6	6	6		6	6			6			
	Bearing														
	Crankshaft														
Valve mechanism	Timing chain														EM-66
	Camshaft														EM-94
	Intake valve timing control	5	5	5	5	5		5	5			5		EM-66	
	Intake valve														EM-107
	Exhaust valve												3		

A
EC
C
D
E
F
G
H
I
J
K
L
M
N
O
P

ENGINE CONTROL SYSTEM SYMPTOMS

< SYMPTOM DIAGNOSIS >

[VQ35DE]

		SYMPTOM												Reference page	
		HARD/NO START/RESTART (EXCP. HA)	ENGINE STALL	HESITATION/SURGING/FLAT SPOT	SPARK KNOCK/DETONATION	LACK OF POWER/POOR ACCELERATION	HIGH IDLE/LOW IDLE	ROUGH IDLE/HUNTING	IDLING VIBRATION	SLOW/NO RETURN TO IDLE	OVERHEATS/WATER TEMPERATURE HIGH	EXCESSIVE FUEL CONSUMPTION	EXCESSIVE OIL CONSUMPTION		BATTERY DEAD (UNDER CHARGE)
Warranty symptom code		AA	AB	AC	AD	AE	AF	AG	AH	AJ	AK	AL	AM	HA	
Exhaust	Exhaust manifold/Tube/Muffler/Gasket	5	5	5	5	5		5	5			5			EM-34, EX-4
	Three way catalyst														
Lubrica-tion	Oil pan/Oil strainer/Oil pump/Oil filter/Oil gallery/Oil cooler	5	5	5	5	5		5	5			5			LU-7, LU-10, LU-11, LU-13
	Oil level (Low)/Filthy oil														LU-7
Cooling	Radiator/Hose/Radiator filler cap														CO-12, CO-12
	Thermostat									5					CO-23
	Water pump	5	5	5	5	5		5	5		4	5			CO-18
	Water gallery														CO-2
	Cooling fan														CO-16
	Coolant level (Low)/Contaminat-ed coolant										5				CO-8
NVIS (NISSAN Vehicle Immobilizer System — NATS)		1	1												SEC-18, SEC-244

1 - 6: The numbers refer to the order of inspection.

NORMAL OPERATING CONDITION

< SYMPTOM DIAGNOSIS >

[VQ35DE]

NORMAL OPERATING CONDITION

Description

INFOID:000000003388293

FUEL CUT CONTROL (AT NO LOAD AND HIGH ENGINE SPEED)

If the engine speed is above 1,400 rpm under no load (for example, the selector lever position is P or N and engine speed is over 1,400 rpm) fuel will be cut off after some time. The exact time when the fuel is cut off varies based on engine speed.

Fuel cut will be operated until the engine speed reaches 1,000 rpm, then fuel cut will be cancelled.

NOTE:

This function is different from deceleration control listed under Multiport Fuel Injection (MFI) System, [EC-28](#), "[System Description](#)".

A
EC
C
D
E
F
G
H
I
J
K
L
M
N
O
P

PRECAUTION

PRECAUTIONS

Precaution for Supplemental Restraint System (SRS) "AIR BAG" and "SEAT BELT PRE-TENSIONER"

INFOID:000000003388294

The Supplemental Restraint System such as "AIR BAG" and "SEAT BELT PRE-TENSIONER", used along with a front seat belt, helps to reduce the risk or severity of injury to the driver and front passenger for certain types of collision. This system includes seat belt switch inputs and dual stage front air bag modules. The SRS system uses the seat belt switches to determine the front air bag deployment, and may only deploy one front air bag, depending on the severity of a collision and whether the front occupants are belted or unbelted. Information necessary to service the system safely is included in the SR and SB section of this Service Manual.

WARNING:

- To avoid rendering the SRS inoperative, which could increase the risk of personal injury or death in the event of a collision which would result in air bag inflation, all maintenance must be performed by an authorized NISSAN/INFINITI dealer.
- Improper maintenance, including incorrect removal and installation of the SRS, can lead to personal injury caused by unintentional activation of the system. For removal of Spiral Cable and Air Bag Module, see the SR section.
- Do not use electrical test equipment on any circuit related to the SRS unless instructed to in this Service Manual. SRS wiring harnesses can be identified by yellow and/or orange harnesses or harness connectors.

Precautions For Xenon Headlamp Service

INFOID:000000003388295

WARNING:

Comply with the following warnings to prevent any serious accident.

- Disconnect the battery cable (negative terminal) or the power supply fuse before installing, removing, or touching the xenon headlamp (bulb included). The xenon headlamp contains high-voltage generated parts.
- Never work with wet hands.
- Check the xenon headlamp ON-OFF status after assembling it to the vehicle. Never turn the xenon headlamp ON in other conditions. Connect the power supply to the vehicle-side connector. (Turning it ON outside the lamp case may cause fire or visual impairments.)
- Never touch the bulb glass immediately after turning it OFF. It is extremely hot.

CAUTION:

Comply with the following cautions to prevent any error and malfunction.

- Install the xenon bulb securely. (Insufficient bulb socket installation may melt the bulb, the connector, the housing, etc. by high-voltage leakage or corona discharge.)
- Never perform HID circuit inspection with a tester.
- Never touch the xenon bulb glass with hands. Never put oil and grease on it.
- Dispose of the used xenon bulb after packing it in thick vinyl without breaking it.
- Never wipe out dirt and contamination with organic solvent (thinner, gasoline, etc.).

Precaution for Procedure without Cowl Top Cover

INFOID:000000003388296

When performing the procedure after removing cowl top cover, cover the lower end of windshield with urethane, etc.

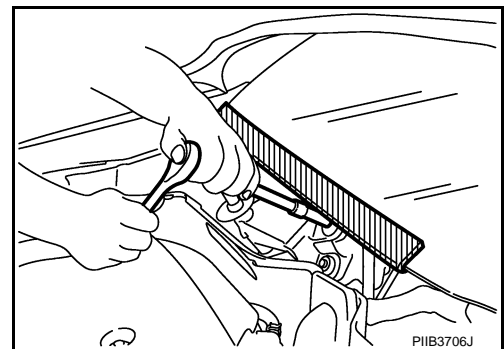

PRECAUTIONS

< PRECAUTION >

[VQ35DE]

On Board Diagnostic (OBD) System of Engine and CVT

INFOID:000000003388297

The ECM has an on board diagnostic system. It will illuminate the malfunction indicator lamp (MIL) to warn the driver of a malfunction causing emission deterioration.

CAUTION:

- Always to turn the ignition switch OFF and disconnect the negative battery cable before any repair or inspection work. The open/short circuit of related switches, sensors, solenoid valves, etc. will cause the MIL to illuminate.
- Always to connect and lock the connectors securely after work. A loose (unlocked) connector will cause the MIL to illuminate due to the open circuit. (Be sure the connector is free from water, grease, dirt, bent terminals, etc.)
- Certain systems and components, especially those related to OBD, may use a new style slide-locking type harness connector. For description and how to disconnect, refer to [PG-96, "Description"](#).
- Always route and secure the harnesses properly after work. The interference of the harness with a bracket, etc. may cause the MIL to illuminate due to the short circuit.
- Always to connect rubber tubes properly after work. A misconnected or disconnected rubber tube may cause the MIL to illuminate due to the malfunction of the EVAP system or fuel injection system, etc.
- Always to erase the unnecessary malfunction information (repairs completed) from the ECM and TCM (Transmission control module) before returning the vehicle to the customer.

General Precautions

INFOID:000000003388298

- Always use a 12 volt battery as power source.
- Never attempt to disconnect battery cables while engine is running.
- Before connecting or disconnecting the ECM harness connector, turn ignition switch OFF and disconnect negative battery cable. Failure to do so may damage the ECM because battery voltage is applied to ECM even if ignition switch is turned OFF.
- Before removing parts, turn ignition switch OFF and then disconnect battery ground cable.

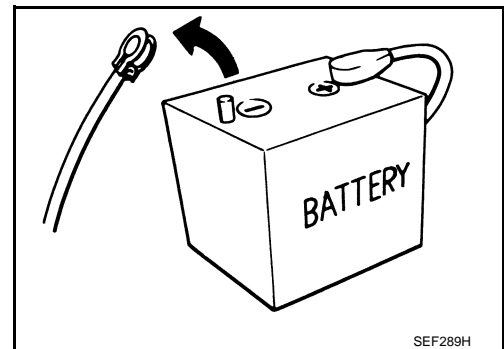

- Never disassemble ECM.
- If a battery cable is disconnected, the memory will return to the ECM value. The ECM will now start to self-control at its initial value. Thus, engine operation can vary slightly in this case. However, this is not an indication of a malfunction. Never replace parts because of a slight variation.
- If the battery is disconnected, the following emission-related diagnostic information will be lost within 24 hours.
 - Diagnostic trouble codes
 - 1st trip diagnostic trouble codes
 - Freeze frame data
 - 1st trip freeze frame data
 - System readiness test (SRT) codes
 - Test values
- When connecting ECM harness connector, fasten (B) it securely with a lever (1) as far as it will go as shown in the figure.
 - ECM (2)
 - Loosen (A)

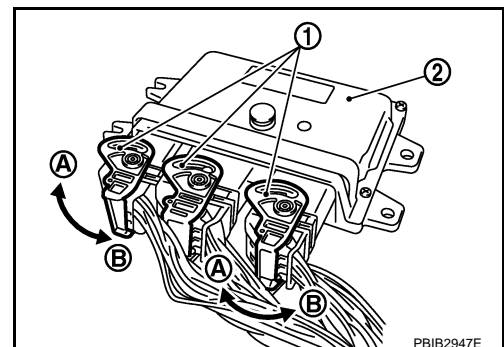

PRECAUTIONS

[VQ35DE]

< PRECAUTION >

- When connecting or disconnecting pin connectors into or from ECM, never damage pin terminals (bends or break). Check that there are not any bends or breaks on ECM pin terminal, when connecting pin connectors.
 - Securely connect ECM harness connectors.
A poor connection can cause an extremely high (surge) voltage to develop in coil and condenser, thus resulting in damage to ICs.
 - Keep engine control system harness at least 10 cm (4 in) away from adjacent harness, to prevent engine control system malfunctions due to receiving external noise, degraded operation of ICs, etc.
 - Keep engine control system parts and harness dry.
 - Before replacing ECM, perform ECM Terminals and Reference Value inspection and check ECM functions properly. Refer to [EC-470, "Reference Value"](#).
 - Handle mass air flow sensor carefully to avoid damage.
 - Never clean mass air flow sensor with any type of detergent.
 - Never disassemble electric throttle control actuator.
 - Even a slight leakage in the air intake system can cause serious incidents.
 - Never shock or jar the camshaft position sensor (PHASE), crankshaft position sensor (POS).
-
- After performing each TROUBLE DIAGNOSIS, perform DTC Confirmation Procedure or Component Function Check. The DTC should not be displayed in the DTC Confirmation Procedure if the repair is completed. The Component Function Check should be a good result if the repair is completed.

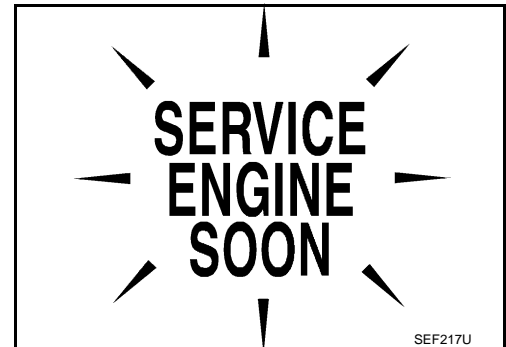
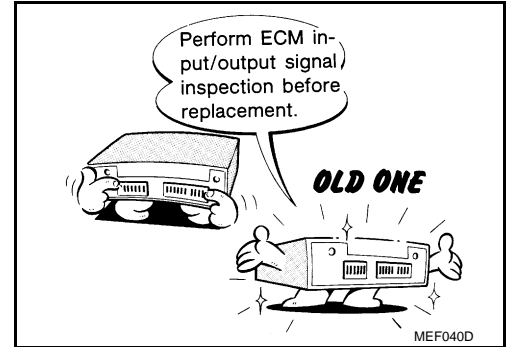
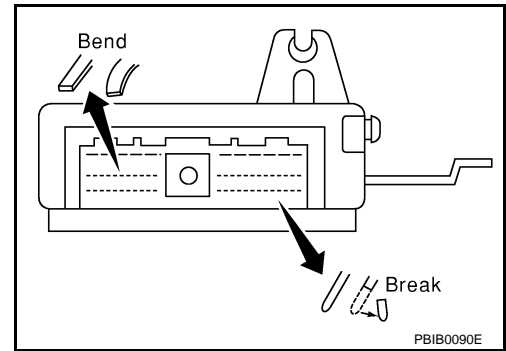

PRECAUTIONS

[VQ35DE]

< PRECAUTION >

- When measuring ECM signals with a circuit tester, never allow the two tester probes to contact. Accidental contact of probes will cause a short circuit and damage the ECM power transistor.

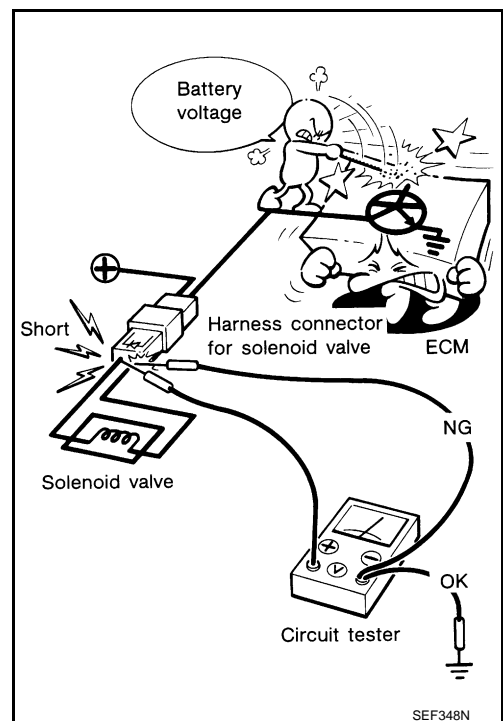

- B1 indicates bank 1, B2 indicates bank 2 as shown in the figure.
- Never operate fuel pump when there is no fuel in lines.
- Tighten fuel hose clamps to the specified torque.

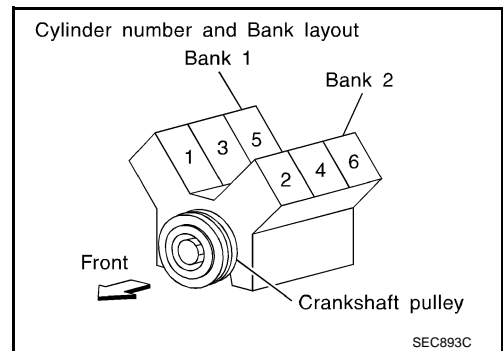

- Never depress accelerator pedal when starting.
- Immediately after starting, never rev up engine unnecessarily.
- Never rev up engine just prior to shutdown.

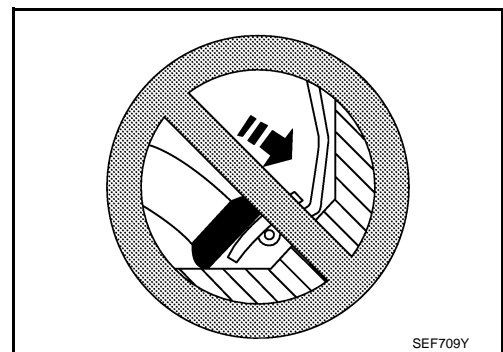

A
EC
C
D
E
F
G
H
I
J
K
L
M
N
O
P

PRECAUTIONS

[VQ35DE]

< PRECAUTION >

- When installing C.B. ham radio or a mobile phone, be sure to observe the following as it may adversely affect electronic control systems depending on installation location.
- Keep the antenna as far as possible from the electronic control units.
- Keep the antenna feeder line more than 20 cm (8 in) away from the harness of electronic controls. Never let them run parallel for a long distance.
- Adjust the antenna and feeder line so that the standing-wave ratio can be kept smaller.
- Be sure to ground the radio to vehicle body.

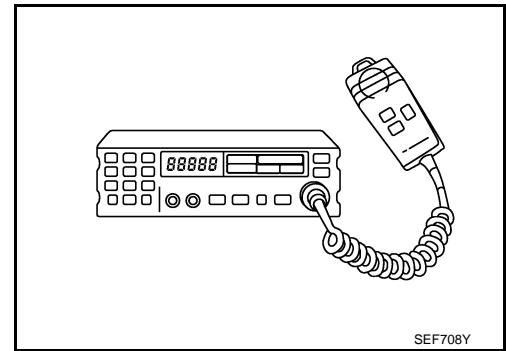

PREPARATION

< PREPARATION >

[VQ35DE]

PREPARATION

PREPARATION

Special Service Tools

INFOID:000000003388299

A

EC

The actual shapes of Kent-Moore tools may differ from those of special service tools illustrated here.

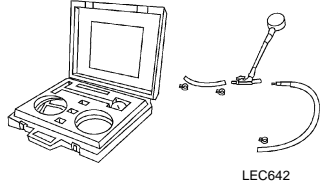
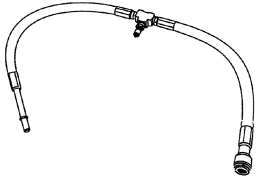
Tool number (Kent-Moore No.) Tool name	Description
(J-44321) Fuel pressure gauge kit  LEC642	Checks fuel pressure
(J-44321-6) Fuel pressure adapter  LBIA0376E	Connects fuel pressure gauge to quick connector type fuel lines

C

D

E

F

G

H

Commercial Service Tools

INFOID:000000003388300

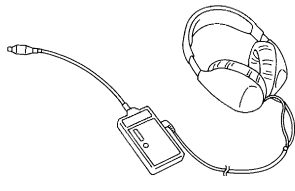
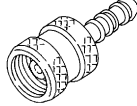
Tool name (Kent-Moore No.)	Description
(J-45488) Quick connector re- lease  PBIC0198E	Removes fuel tube quick connectors in engine room
Leak detector i.e.: (J-41416)  S-NT703	Locates the EVAP leakage
EVAP service port adapter i.e.: (J-41413-OB)  S-NT704	Applys positive pressure through EVAP service port

I

J

K

L

M

N

O

P

PREPARATION

[VQ35DE]

< PREPARATION >

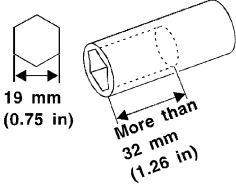
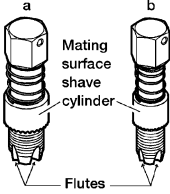
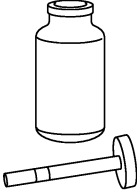
Tool name (Kent-Moore No.)	Description
Fuel filler cap adapter i.e.: (MLR-8382) <div style="text-align: center;">  <p>S-NT815</p> </div>	Checks fuel tank vacuum relief valve opening pressure
Socket wrench <div style="text-align: center;">  <p>S-NT705</p> </div>	Removes and installs engine coolant temperature sensor
Oxygen sensor thread cleaner i.e.: (J-43897-18) (J-43897-12) <div style="text-align: center;">  <p>AEM488</p> </div>	Reconditions the exhaust system threads before installing a new oxygen sensor. Use with anti-seize lubricant shown below. a: 18 mm diameter with pitch 1.5 mm for Zirconia Oxygen Sensor b: 12 mm diameter with pitch 1.25 mm for Titanium Oxygen Sensor
Anti-seize lubricant i.e.: (Permatex™ 133AR or equivalent meeting MIL specification MIL-A-907) <div style="text-align: center;">  <p>S-NT779</p> </div>	Lubricates oxygen sensor thread cleaning tool when reconditioning exhaust system threads.

ON-VEHICLE MAINTENANCE

FUEL PRESSURE

Inspection

INFOID:000000003388301

FUEL PRESSURE RELEASE

④ With CONSULT-III

1. Turn ignition switch ON.
2. Perform "FUEL PRESSURE RELEASE" in "WORK SUPPORT" mode with CONSULT-III.
3. Start engine.
4. After engine stalls, crank it 2 or 3 times to release all fuel pressure.
5. Turn ignition switch OFF.

⊗ Without CONSULT-III

1. Remove fuel pump fuse (2) located in IPDM E/R (1).
2. Start engine.
3. After engine stalls, crank it 2 or 3 times to release all fuel pressure.
4. Turn ignition switch OFF.
5. Reinstall fuel pump fuse after servicing fuel system.

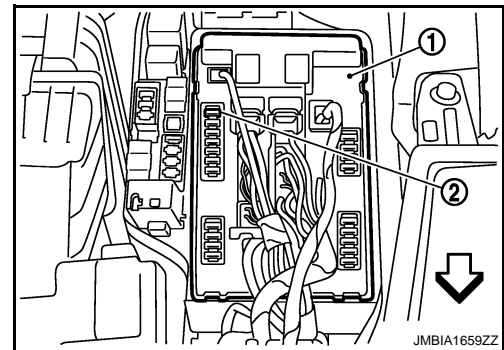

FUEL PRESSURE CHECK

CAUTION:

Before disconnecting fuel line, release fuel pressure from fuel line to eliminate danger.

NOTE:

- Prepare pans or saucers under the disconnected fuel line because the fuel may spill out. The fuel pressure cannot be completely released because Z51 models do not have fuel return system.
- Be careful not to scratch or get the fuel hose connection area dirty when servicing, so that the quick connector o-ring maintains seal ability.
- Use Fuel Pressure Gauge Kit [SST (J-44321)] and Fuel Pressure Adapter [SST (J-44321-6)] to check fuel pressure.

1. Release fuel pressure to zero.
2. Remove fuel hose using Quick Connector Release [SST (J-45488)].
 - Do not twist or kink fuel hose because it is plastic hose.
 - Do not remove fuel hose (1) from quick connector.
 - Keep fuel hose connections clean.
3. Install Fuel Pressure Adapter [SST (J-44321-6)] (B) and Fuel Pressure Gauge kit [SST (J44321)] (A) as shown in figure.
 - Do not distort or bend fuel rail tube when installing fuel pressure gauge adapter.
 - When reconnecting fuel hose, check the original fuel hose for damage and abnormality.
4. Turn ignition switch ON (reactivate fuel pump) and check for fuel leakage.
5. Start engine and check for fuel leakage.
6. Read the indication of fuel pressure gauge kit [SST (J-44321)].
 - During fuel pressure check, check for fuel leakage from fuel connection every 3 minutes.

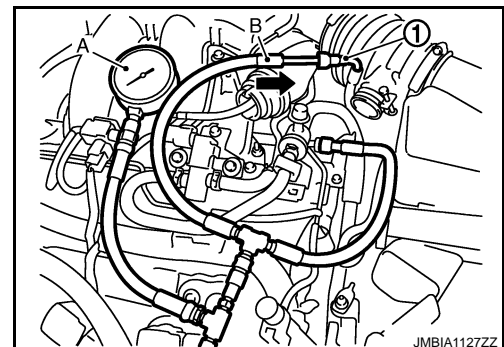

At idling : Approximately 350 kPa (3.57 kg/cm², 51 psi)

FUEL PRESSURE

< ON-VEHICLE MAINTENANCE >

[VQ35DE]

7. If result is unsatisfactory, go to next step.
8. Check the following.
 - Fuel hoses and fuel tubes for clogging
 - Fuel filter for clogging
 - Fuel pump
 - Fuel pressure regulator for clogging
9. If OK, replace fuel pressure regulator.
If NG, repair or replace malfunctioning part.
10. Before disconnecting Fuel Pressure Gauge kit [SST (J-44321)] and Fuel Pressure Adapter [SST (J-44321-6)], release fuel pressure to zero.

EVAP LEAK CHECK

< ON-VEHICLE MAINTENANCE >

[VQ35DE]

EVAP LEAK CHECK

Inspection

INFOID:000000003388302

CAUTION:

- Never use compressed air or a high pressure pump.
- Never exceed 4.12 kPa (0.042 kg/cm², 0.6 psi) of pressure in EVAP system.

NOTE:

- Do not start engine.
- Improper installation of EVAP service port adapter (commercial service tool) to the EVAP service port may cause a leakage.

Ⓟ WITH CONSULT-III

1. To locate the EVAP leakage, install EVAP service port adapter (commercial service tool) and pressure pump to EVAP service port.
2. Turn ignition switch ON.
3. Select the "EVAP SYSTEM CLOSE" of "WORK SUPPORT MODE" with CONSULT-III.
4. Touch "START". A bar graph (Pressure indicating display) will appear on the screen.
5. Apply positive pressure to the EVAP system until the pressure indicator reaches the middle of the bar graph.
6. Remove EVAP service port adapter (commercial service tool) and hose with pressure pump.
7. Locate the leakage using a leakage detector (commercial service tool). Refer to [EC-77, "System Diagram"](#).

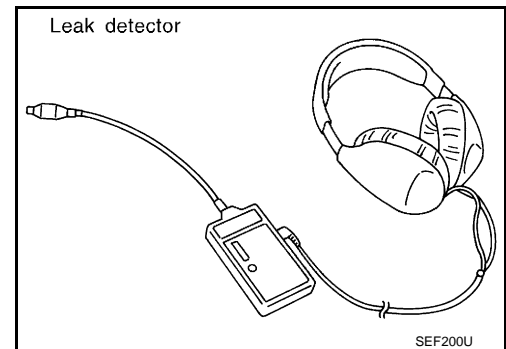
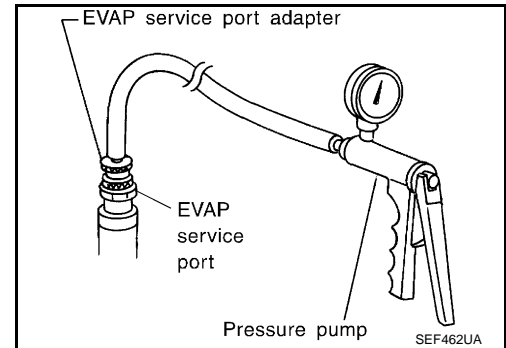

ⓧ WITHOUT CONSULT-III

1. To locate the EVAP leakage, install EVAP service port adapter (commercial service tool) and pressure pump to EVAP service port.
2. Apply battery voltage between the terminals of EVAP canister vent control valve to make a closed EVAP system.
3. To locate the leakage, deliver positive pressure to the EVAP system until pressure gauge points reach 1.38 to 2.76 kPa (0.014 to 0.028 kg/cm², 0.2 to 0.4 psi).
4. Remove EVAP service port adapter (commercial service tool) and hose with pressure pump.

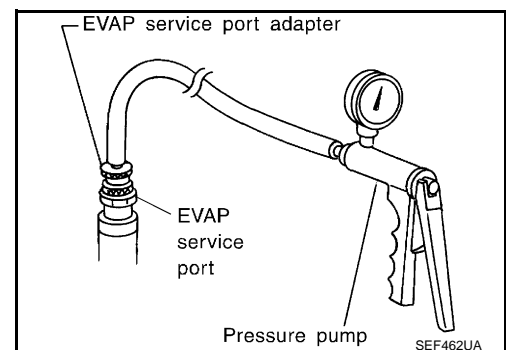

A
EC
C
D
E
F
G
H
I
J
K
L
M
N
O
P

EVAP LEAK CHECK

< ON-VEHICLE MAINTENANCE >

[VQ35DE]

5. Locate the leakage using a leak detector (commercial service tool). Refer to [EC-77, "System Diagram"](#).

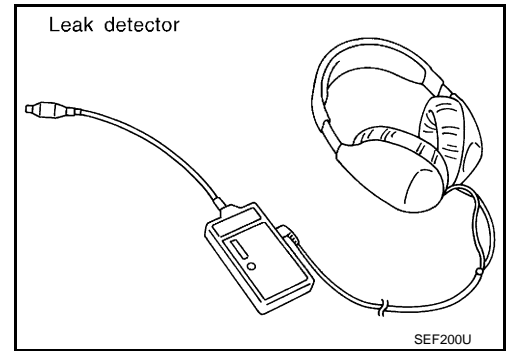

ON-VEHICLE REPAIR

EVAP CANISTER

Exploded View

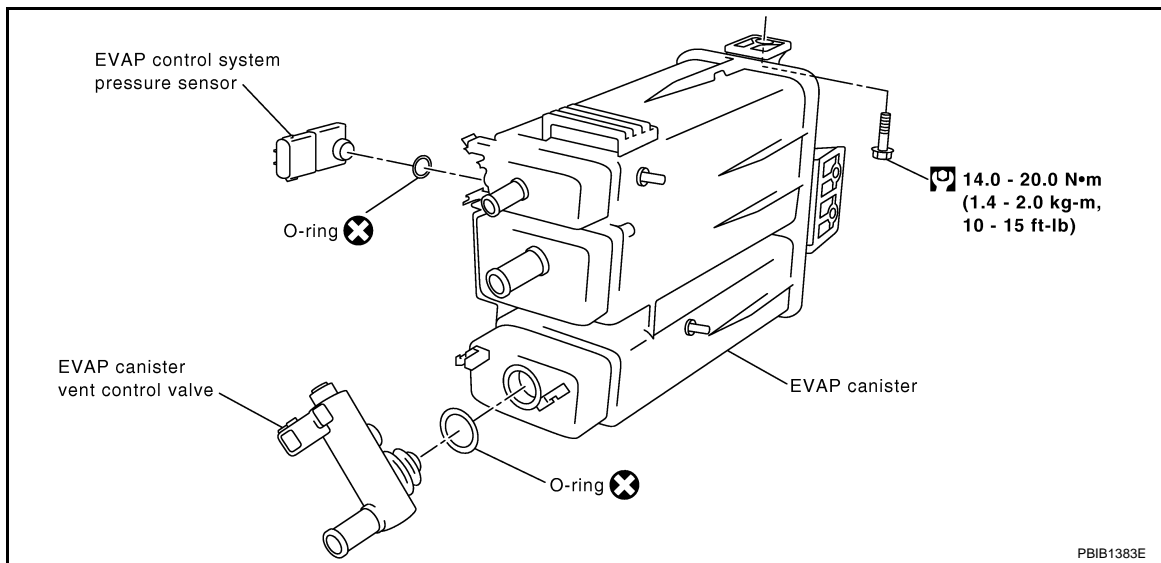

Removal and Installation

INFOID:000000003388304

REMOVAL

1. Lift up the vehicle.
2. Remove EVAP canister fixing bolt.
3. Remove EVAP canister.

NOTE:

The EVAP canister vent control valve and EVAP canister system pressure sensor can be removed without removing the EVAP canister.

INSTALLATION

Install in the reverse order of removal.

NOTE:

Tighten EVAP canister fixing bolt to the specified torque.

DISASSEMBLY

1. Turn EVAP canister vent control valve counterclockwise.
2. Remove the EVAP canister vent control valve.

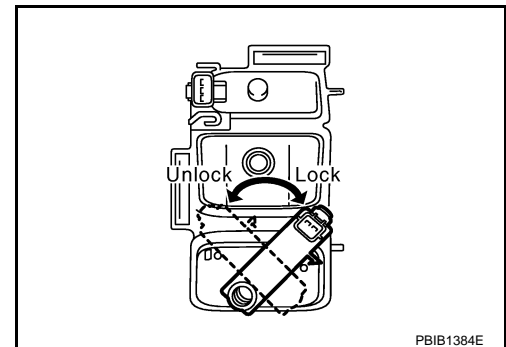

ASSEMBLY

Assemble in the reverse order of disassembly.

CAUTION:

Always replace O-ring with a new one.

EVAP CANISTER

< ON-VEHICLE REPAIR >

[VQ35DE]

INFOID:000000003388305

Inspection

Check EVAP canister as per the following:

1. Block port (B).
2. Blow air into port (A) and check that it flows freely out of port (C).
3. Release blocked port (B).
4. Apply vacuum pressure to port (B) and check that vacuum pressure exists at the ports (A) and (C).
5. Block port (A) and (B).
6. Apply pressure to port (C) and check that there is no leakage.

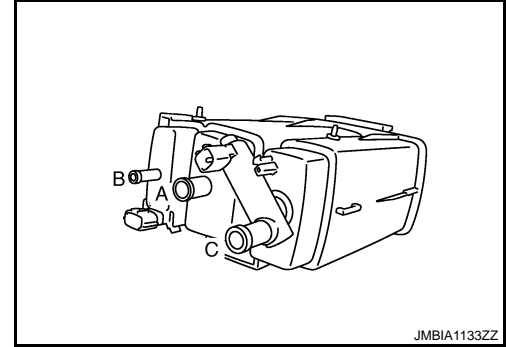

JMBIA1133ZZ

SERVICE DATA AND SPECIFICATIONS (SDS)

< SERVICE DATA AND SPECIFICATIONS (SDS)

[VQ35DE]

SERVICE DATA AND SPECIFICATIONS (SDS)

SERVICE DATA AND SPECIFICATIONS (SDS)

Idle Speed

INFOID:0000000003388306

Condition	Specification
No load* (in P or N position)	600 ± 50 rpm

*: Under the following conditions

- A/C switch: OFF
- Electric load: OFF (Lights, heater fan & rear window defogger)
- Steering wheel: Kept in straight-ahead position

Ignition Timing

INFOID:0000000003388307

Condition	Specification
No load* (in P or N position)	12 ± 5° BTDC

*: Under the following conditions

- A/C switch: OFF
- Electric load: OFF (Lights, heater fan & rear window defogger)
- Steering wheel: Kept in straight-ahead position

Calculated Load Value

INFOID:0000000003388308

Condition	Specification (Using CONSULT-III or GST)
At idle	10 – 35 %
At 2,500 rpm	10 – 35 %

Mass Air Flow Sensor

INFOID:0000000003388309

Supply voltage	Battery voltage (11 – 14 V)
Output voltage at idle (in N position)	0.9 – 1.2 V*
Mass air flow (Using CONSULT-III or GST)	2.0 – 6.0 g-m/sec at idle* 7.0 – 20.0 g-m/sec at 2,500 rpm*

*: Engine is warmed up to normal operating temperature and running under no load.