

A
B
C
D
E

SECTION **BRC**

BRAKE CONTROL SYSTEM

CONTENTS

		BRC
VDC/TCS/ABS	Component Description20	
BASIC INSPECTION 5	ABS21	
DIAGNOSIS AND REPAIR WORK FLOW 5	System Diagram21	G
Work Flow5	System Description21	
Diagnostic Work Sheet8	Component Parts Location21	
INSPECTION AND ADJUSTMENT 9	Component Description24	H
ADJUSTMENT OF STEERING ANGLE SENSOR NEUTRAL POSITION9	EBD25	
ADJUSTMENT OF STEERING ANGLE SENSOR NEUTRAL POSITION : Description9	System Diagram25	I
ADJUSTMENT OF STEERING ANGLE SENSOR NEUTRAL POSITION : Special Repair Requirement9	System Description25	
CALIBRATION OF YAW RATE/SIDE/DECEL G SENSOR10	Component Parts Location25	J
CALIBRATION OF YAW RATE/SIDE/DECEL G SENSOR : Description10	Component Description28	
CALIBRATION OF YAW RATE/SIDE/DECEL G SENSOR : Special Repair Requirement10	DIAGNOSIS SYSTEM [ABS ACTUATOR AND ELECTRIC UNIT (CONTROL UNIT)]29	K
CALIBRATION OF PRESSURE SENSOR11	CONSULT-III Function29	
CALIBRATION OF PRESSURE SENSOR : Description11	COMPONENT DIAGNOSIS34	L
CALIBRATION OF PRESSURE SENSOR : Special Repair Requirement11	C1101, C1102, C1103, C1104 WHEEL SENSOR34	
FUNCTION DIAGNOSIS13	Description34	M
VDC13	DTC Logic34	
System Diagram13	Diagnosis Procedure34	N
System Description13	Component Inspection36	
Component Parts Location13	Special Repair Requirement36	O
Component Description16	C1105, C1106, C1107, C1108 WHEEL SENSOR38	
TCS17	Description38	P
System Diagram17	DTC Logic38	
System Description17	Diagnosis Procedure38	
Component Parts Location17	Component Inspection40	
	Special Repair Requirement40	
	C1109 POWER AND GROUND SYSTEM41	
	Description41	
	DTC Logic41	
	Diagnosis Procedure41	
	Special Repair Requirement42	

C1110, C1170 ABS ACTUATOR AND ELECTRIC UNIT (CONTROL UNIT)	43	Diagnosis Procedure	62
Description	43	Component Inspection	63
DTC Logic	43	Special Repair Requirement	63
Diagnosis Procedure	43		
Special Repair Requirement	43		
C1111 ABS MOTOR, MOTOR RELAY SYSTEM	44	C1142 PRESS SENSOR	64
Description	44	Description	64
DTC Logic	44	DTC Logic	64
Diagnosis Procedure	44	Diagnosis Procedure	64
Component Inspection	45	Component Inspection	64
Special Repair Requirement	45	Special Repair Requirement	65
C1113, C1145, C1146 YAW RATE/SIDE/DECEL G SENSOR	46	C1143 STEERING ANGLE SENSOR	66
Description	46	Description	66
DTC Logic	46	DTC Logic	66
Diagnosis Procedure	46	Diagnosis Procedure	66
Component Inspection	47	Component Inspection	67
Special Repair Requirement	48	Special Repair Requirement	67
C1115 WHEEL SENSOR	49	C1144 INCOMPLETE STEERING ANGLE SENSOR ADJUSTMENT	68
Description	49	DTC Logic	68
DTC Logic	49	Diagnosis Procedure	68
Diagnosis Procedure	49	Special Repair Requirement	68
Component Inspection	51	C1155 BRAKE FLUID LEVEL SWITCH	69
Special Repair Requirement	51	Description	69
C1116 STOP LAMP SWITCH	52	DTC Logic	69
Description	52	Diagnosis Procedure	69
DTC Logic	52	Component Inspection	70
Diagnosis Procedure	52	Special Repair Requirement	70
Component Inspection	53	C1160, C1161 INCOMPLETE YAW RATE/SIDE/DECEL G SENSOR CALIBRATION	71
Special Repair Requirement	53	DTC Logic	71
C1120, C1122, C1124, C1126 IN ABS SOL	54	Diagnosis Procedure	71
Description	54	Special Repair Requirement	71
DTC Logic	54	C1162 INCOMPLETE PRESSURE SENSOR CALIBRATION	72
Diagnosis Procedure	54	Description	72
Component Inspection	55	DTC Logic	72
Special Repair Requirement	55	Diagnosis Procedure	72
C1121, C1123, C1125, C1127 OUT ABS SOL ..	57	Special Repair Requirement	72
Description	57	C1164, C1165 CV SYSTEM	73
DTC Logic	57	Description	73
Diagnosis Procedure	57	DTC Logic	73
Component Inspection	58	Diagnosis Procedure	73
Special Repair Requirement	58	Component Inspection	74
C1130 ENGINE SIGNAL	60	Special Repair Requirement	74
Description	60	C1166, C1167 SV SYSTEM	75
DTC Logic	60	Description	75
Diagnosis Procedure	60	DTC Logic	75
Special Repair Requirement	60	Diagnosis Procedure	75
C1140 ACTUATOR RELAY SYSTEM	62	Component Inspection	76
Description	62	Special Repair Requirement	76
DTC Logic	62	U1000, U1002 CAN COMM CIRCUIT	77
		Description	77
		DTC Logic	77

Diagnosis Procedure	77	PEDAL VIBRATION OR ABS OPERATION	
Special Repair Requirement	77	SOUND OCCURS	108
POWER SUPPLY AND GROUND CIRCUIT	78	Diagnosis Procedure	108
Description	78	VEHICLE JERKS DURING VDC/TCS/ABS	
Diagnosis Procedure	78	CONTROL	109
PARKING BRAKE SWITCH	80	Diagnosis Procedure	109
Component Function Check	80	NORMAL OPERATING CONDITION	110
Diagnosis Procedure	80	Description	110
Component Inspection	80	PRECAUTION	111
VDC OFF SWITCH	82	PRECAUTIONS	111
Description	82	FOR USA AND CANADA	111
Component Function Check	82	FOR USA AND CANADA : Precaution for Supple-	
Diagnosis Procedure	82	mental Restraint System (SRS) "AIR BAG" and	
Component Inspection	83	"SEAT BELT PRE-TENSIONER"	111
ABS WARNING LAMP	84	FOR USA AND CANADA : Precaution for Proce-	
Description	84	dure without Cowl Top Cover	111
Component Function Check	84	FOR USA AND CANADA : Precaution for Brake	
Diagnosis Procedure	84	System	111
BRAKE WARNING LAMP	85	FOR USA AND CANADA : Precaution for Brake	
Description	85	Control	112
Component Function Check	85	FOR MEXICO	112
Diagnosis Procedure	85	FOR MEXICO : Precaution for Supplemental Re-	
VDC OFF INDICATOR LAMP	86	straint System (SRS) "AIR BAG" and "SEAT BELT	
Description	86	PRE-TENSIONER"	112
Component Function Check	86	FOR MEXICO : Precaution for Procedure without	
Diagnosis Procedure	86	Cowl Top Cover	113
SLIP INDICATOR LAMP	87	FOR MEXICO : Precaution for Brake System	113
Description	87	FOR MEXICO : Precaution for Brake Control	113
Component Function Check	87	ON-VEHICLE REPAIR	114
Diagnosis Procedure	87	WHEEL SENSOR	114
ECU DIAGNOSIS	88	FRONT WHEEL SENSOR	114
ABS ACTUATOR AND ELECTRIC UNIT		FRONT WHEEL SENSOR : Exploded View	114
(CONTROL UNIT)	88	FRONT WHEEL SENSOR : Removal and Instal-	
Reference Value	88	lation	114
Wiring Diagram -BRAKE CONTROL SYSTEM-	91	REAR WHEEL SENSOR	115
Fail-Safe	101	REAR WHEEL SENSOR : Exploded View	115
DTC No. Index	102	REAR WHEEL SENSOR : Removal and Installa-	
SYMPTOM DIAGNOSIS	104	tion	115
EXCESSIVE ABS FUNCTION OPERATION		SENSOR ROTOR	116
FREQUENCY	104	FRONT SENSOR ROTOR	116
Diagnosis Procedure	104	FRONT SENSOR ROTOR : Exploded View	116
UNEXPECTED PEDAL REACTION	105	FRONT SENSOR ROTOR : Removal and Instal-	
Diagnosis Procedure	105	lation	116
THE BRAKING DISTANCE IS LONG	106	REAR SENSOR ROTOR	116
Diagnosis Procedure	106	REAR SENSOR ROTOR : Exploded View	116
ABS FUNCTION DOES NOT OPERATE	107	REAR SENSOR ROTOR : Removal and Installa-	
Diagnosis Procedure	107	tion	116

BRC

A
B
C
D
E
G
H
I
J
K
L
M
N
O
P

ABS ACTUATOR AND ELECTRIC UNIT (CONTROL UNIT)	117	Exploded View	119
Exploded View	117	Removal and Installation	119
Removal and Installation	117	STEERING ANGLE SENSOR	120
G SENSOR	119	Exploded View	120
		Removal and Installation	120

BASIC INSPECTION

DIAGNOSIS AND REPAIR WORK FLOW

Work Flow

INFOID:000000003247124

PRECAUTIONS FOR DIAGNOSIS

Adjustment of Steering Angle Sensor

If steering angle sensor, steering system parts, suspension system parts, ABS actuator and electric unit (control unit) or tires have been replaced, or if wheel alignment has been adjusted, be sure to adjust neutral position of steering angle sensor before driving. Refer to [BRC-9, "ADJUSTMENT OF STEERING ANGLE SENSOR NEUTRAL POSITION : Description"](#).

Calibration of Yaw Rate/Side/Decel G Sensor

If yaw rate/side/decel G sensor or ABS actuator and electric unit (control unit) have been replaced, be sure to calibrate yaw rate/side/decel G sensor before driving. Refer to [BRC-10, "CALIBRATION OF YAW RATE/SIDE/DECEL G SENSOR : Description"](#).

Calibration of Pressure Sensor

If ABS actuator and electric unit (control unit) have been replaced, be sure to calibrate pressure sensor before driving. Refer to [BRC-11, "CALIBRATION OF PRESSURE SENSOR : Description"](#).

A
B
C
D
E
G
H
I
J
K
L
M
N
O
P

BRC

DIAGNOSIS AND REPAIR WORK FLOW

< BASIC INSPECTION >

[VDC/TCS/ABS]

OVERALL SEQUENCE

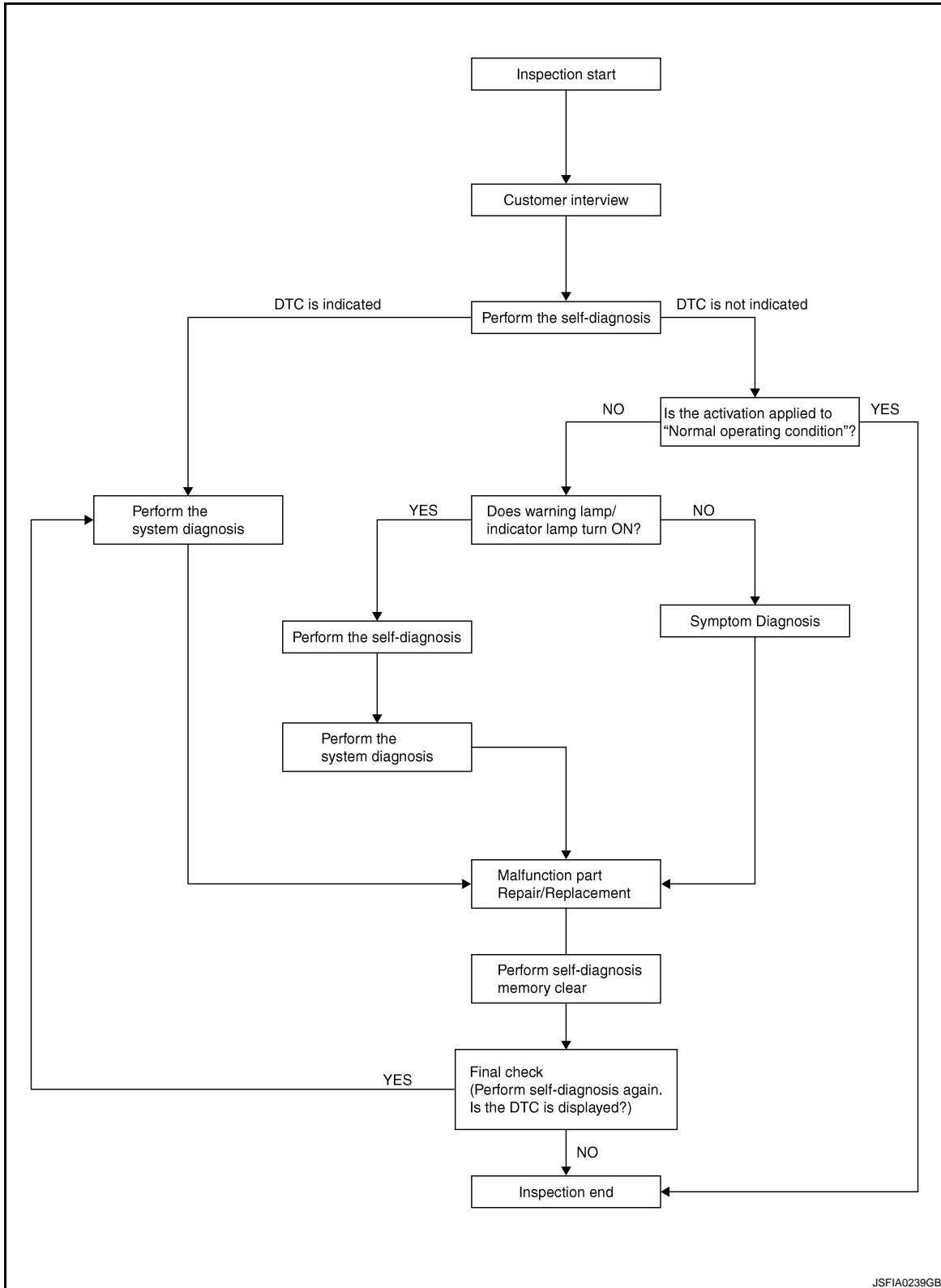

DETAILED FLOW

1. COLLECT THE INFORMATION FROM THE CUSTOMER

Get the detailed information from the customer about the symptom (the condition and the environment when the incident/malfunction occurred) using the diagnosis worksheet. Refer to [BRC-8, "Diagnostic Work Sheet"](#).

>> GO TO 2.

DIAGNOSIS AND REPAIR WORK FLOW

[VDC/TCS/ABS]

< BASIC INSPECTION >

2. PERFORM THE SELF-DIAGNOSIS

Check the DTC display with the self-diagnosis function.

Is there any DTC displayed?

YES >> GO TO 3.

NO >> GO TO 4.

3. PERFORM THE SYSTEM DIAGNOSIS

Perform the diagnosis applicable to the displayed DTC. Refer to [BRC-102, "DTC No. Index"](#).

>> GO TO 7.

4. CHECK THE SYMPTOM THAT IS NOT CONSIDERED A SYSTEM MALFUNCTION

Check that the symptom is a normal operation that is not considered a system malfunction. Refer to [BRC-110, "Description"](#).

Is the symptom a normal operation?

YES >> INSPECTION END

NO >> GO TO 5.

5. CHECK THE WARNING LAMP AND INDICATOR LAMP FOR ILLUMINATION

Check that the warning lamp and indicator lamp illuminate.

- ABS warning lamp: Refer to [BRC-84, "Description"](#).
- Brake warning lamp: Refer to [BRC-85, "Description"](#).
- VDC OFF indicator lamp: Refer to [BRC-86, "Description"](#).
- SLIP indicator lamp: Refer to [BRC-87, "Description"](#).

Is ON/OFF timing normal?

YES >> GO TO 6.

NO >> GO TO 2.

6. PERFORM THE DIAGNOSIS BY SYMPTOM

Perform the diagnosis applicable to the symptom.

>> GO TO 7.

7. REPAIR OR REPLACE THE MALFUNCTIONING PARTS

Repair or replace the specified malfunctioning parts.

>> GO TO 8.

8. MEMORY CLEAR

Perform self-diagnosis memory clear.

>> GO TO 9.

9. FINAL CHECK

Perform the self-diagnosis again, and check that the malfunction is repaired completely.

Is no other DTC present and the repair completed?

YES >> INSPECTION END

NO >> GO TO 3.

A
B
C
D
E
BRC
G
H
I
J
K
L
M
N
O
P

DIAGNOSIS AND REPAIR WORK FLOW

< BASIC INSPECTION >

[VDC/TCS/ABS]

Diagnostic Work Sheet

INFOID:000000003247125

Customer name MR/MS	Model & Year	VIN	
Engine #	Trans.	Mileage	
Incident Date	Manuf. Date	In Service Date	
Symptoms	<input type="checkbox"/> Noise and vibration (from engine compartment) <input type="checkbox"/> Noise and vibration (from axle)	<input type="checkbox"/> Warning / Indicator activate	<input type="checkbox"/> Firm pedal operation <input type="checkbox"/> Large stroke pedal operation
	<input type="checkbox"/> TCS does not work (Rear wheels slip when accelerating)	<input type="checkbox"/> ABS does not work (Wheels lock when braking)	<input type="checkbox"/> Lack of sense of acceleration
Engine conditions	<input type="checkbox"/> When starting <input type="checkbox"/> After starting		
Road conditions	<input type="checkbox"/> Low friction road (<input type="checkbox"/> Snow <input type="checkbox"/> Gravel <input type="checkbox"/> Other) <input type="checkbox"/> Bumps / potholes		
Driving conditions	<input type="checkbox"/> Full-acceleration <input type="checkbox"/> High speed cornering <input type="checkbox"/> Vehicle speed: Greater than 10 km/h (6 MPH) <input type="checkbox"/> Vehicle speed: 10 km/h (6 MPH) or less <input type="checkbox"/> Vehicle is stopped		
Applying brake conditions	<input type="checkbox"/> Suddenly <input type="checkbox"/> Gradually		
Other conditions	<input type="checkbox"/> Operation of electrical equipment <input type="checkbox"/> Shift change <input type="checkbox"/> Other descriptions		

SFIA3265E

INSPECTION AND ADJUSTMENT

ADJUSTMENT OF STEERING ANGLE SENSOR NEUTRAL POSITION

ADJUSTMENT OF STEERING ANGLE SENSOR NEUTRAL POSITION : Description

INFOID:000000003247126

When doing work that applies to the list below, make sure to adjust neutral position of steering angle sensor before running vehicle.

×: Required –: Not required

Situation	Adjustment of steering angle sensor neutral position
Removing/Installing ABS actuator and electric unit (control unit)	—
Replacing ABS actuator and electric unit (control unit)	×
Removing/Installing steering angle sensor	×
Replacing steering angle sensor	×
Removing/Installing steering components	×
Replacing steering components	×
Removing/Installing suspension components	×
Replacing suspension components	×
Change tires to new ones	—
Tire rotation	—
Adjusting wheel alignment	×

ADJUSTMENT OF STEERING ANGLE SENSOR NEUTRAL POSITION : Special Repair Requirement

INFOID:000000003247127

ADJUSTMENT OF STEERING ANGLE SENSOR NEUTRAL POSITION

CAUTION:

To adjust neutral position of steering angle sensor, make sure to use CONSULT-III (Adjustment cannot be done without CONSULT-III)

1. ALIGN THE VEHICLE STATUS

Stop the vehicle with front wheels in straight-ahead position.

>> GO TO 2.

2. PERFORM THE NEUTRAL POSITION ADJUSTMENT FOR THE STEERING ANGLE SENSOR

1. On the CONSULT-III screen, touch "WORK SUPPORT" and "ST ANGLE SENSOR ADJUSTMENT" in order.
2. Touch "START".

CAUTION:

Do not touch steering wheel while adjusting steering angle sensor.

3. After approximately 10 seconds, touch "END".

NOTE:

After approximately 60 seconds, it ends automatically.

4. Turn the ignition switch OFF, then turn it ON again.

CAUTION:

Be sure to perform above operation.

>> GO TO 3.

3. CHECK DATA MONITOR

1. Run the vehicle with front wheels in straight-ahead position, then stop.
2. Select "STR ANGLE SIG" in "DATA MONITOR" and check steering angle sensor signal.

STR ANGLE SIG : 0±2.5°

INSPECTION AND ADJUSTMENT

[VDC/TCS/ABS]

< BASIC INSPECTION >

Is the steering angle within the specified range?

YES >> GO TO 4.

NO >> Perform the neutral position adjustment for the steering angle sensor again, GO TO 1.

4. ERASE THE SELF-DIAGNOSIS MEMORY

Erase the self-diagnosis memories of the ABS actuator and electric unit (control unit) and ECM.

- ABS actuator and electric unit (control unit): Refer to [BRC-29, "CONSULT-III Function"](#).
- ECM: Refer to [EC-102, "Diagnosis Description"](#).

Are the memories erased?

YES >> INSPECTION END

NO >> Check the items indicated by the self-diagnosis.

CALIBRATION OF YAW RATE/SIDE/DECEL G SENSOR

CALIBRATION OF YAW RATE/SIDE/DECEL G SENSOR : Description

INFOID:000000003247292

When doing work that applies to the list below, make sure to calibration of yaw rate/side/decel G sensor before running vehicle.

×: Required –: Not required

Situation	Calibration of yaw rate/side/decel G sensor
Removing/Installing ABS actuator and electric unit (control unit)	×
Replacing ABS actuator and electric unit (control unit)	×
Removing/Installing steering components	—
Removing/Installing suspension components	—
Change tires to new ones	—
Tire rotation	—
Adjusting wheel alignment	—
Removing/Installing yaw rate/side/decel G sensor	×
Replacing yaw rate/side/decel G sensor	×

CALIBRATION OF YAW RATE/SIDE/DECEL G SENSOR : Special Repair Requirement

INFOID:000000003247293

CALIBRATION OF YAW RATE/SIDE/DECEL G SENSOR

CAUTION:

- To calibrate yaw rate/side/decel G sensor, make sure to use CONSULT-III.
(Calibration cannot be done without CONSULT-III.)
- Perform the G sensor calibration only with the vehicle parked on level surface.

1. ALIGN THE VEHICLE STATUS

Stop the vehicle with front wheels in straight-ahead position.

CAUTION:

- Keep all tires inflated to correct pressures. Adjust the tire pressure to the specified pressure value.
- Check that there is specified-load in vehicle other than the driver (or equivalent weight placed in driver's position).

>> GO TO 2.

2. PERFORM THE CALIBRATION OF YAW RATE/SIDE/DECEL G SENSOR

1. On the CONSULT-III screen, touch "WORK SUPPORT" and "DECEL G SEN CALIBRATION" in order.
2. Touch "START".
3. After approximately 10 seconds, touch "END".

NOTE:

After approximately 60 seconds, it ends automatically.

4. Turn the ignition switch OFF, then turn it ON again.

CAUTION:

Be sure to perform above operation.

>> GO TO 3.

3. CHECK DATA MONITOR

1. Run the vehicle with front wheels in straight-ahead position, then stop.
2. Select "DECEL G-SEN" in "DATA MONITOR" and check yaw rate/side/decel G sensor signal.

DECEL G-SEN : ±0.08 G

Is the yaw rate/side/decel G within the specified range?

YES >> GO TO 4.

NO >> Perform the calibration of yaw rate/side/decel G sensor again, GO TO 1.

4. ERASE THE SELF-DIAGNOSIS MEMORY

Erase the self-diagnosis memories of the ABS actuator and electric unit (control unit) and ECM.

- ABS actuator and electric unit (control unit): Refer to [BRC-29, "CONSULT-III Function"](#).
- ECM: Refer to [EC-102, "Diagnosis Description"](#).

Are the memories erased?

YES >> INSPECTION END

NO >> Check the items indicated by the self-diagnosis.

CALIBRATION OF PRESSURE SENSOR

CALIBRATION OF PRESSURE SENSOR : Description

INFOID:000000004684882

When doing work that applies to the list below, make sure to calibrate pressure sensor before running vehicle.

×: Required –: Not required

Situation	Calibration of pressure sensor
Removing/Installing ABS actuator and electric unit (control unit)	—
Replacing ABS actuator and electric unit (control unit)	×
Removing/Installing brake components	—
Replacing brake components	—
Performing air bleeding from brake piping	—
Replacing brake fluid	—

CALIBRATION OF PRESSURE SENSOR : Special Repair Requirement

INFOID:000000004684883

CALIBRATION OF PRESSURE SENSOR

CAUTION:

- To calibrate pressure sensor, make sure to use CONSULT-III.
(Calibration cannot be done without CONSULT-III.)
- Perform the pressure sensor calibration with the vehicle stopped.
- Never depress the brake pedal during the pressure sensor calibration.

1. PERFORM THE CALIBRATION OF PRESSURE SENSOR

1. On the CONSULT-III screen, touch "WORK SUPPORT" and "PRESS SEN CALIBRATION" in order.
2. Touch "START".
3. After approximately 10 seconds, touch "END".
4. Turn the ignition switch OFF, then turn it ON again.

CAUTION:

Always perform the above operation.

>> GO TO 2.

2. CHECK DATA MONITOR

Select "PRESS SENSOR" in "DATA MONITOR" and check pressure sensor signal.

A
B
C
D
E
G
H
I
J
K
L
M
N
O
P



INSPECTION AND ADJUSTMENT

< BASIC INSPECTION >

[VDC/TCS/ABS]

Condition	DATA MONITOR
Brake pedal is released	Approx. 0 bar
Brake pedal is depressed	Approx. -40 – 300 bar

Is the pressure within the specified range?

YES >> GO TO 3.

NO >> Check pressure sensor. Refer to [BRC-64. "Diagnosis Procedure"](#).

3. ERASE THE SELF-DIAGNOSIS MEMORY

Erase the self-diagnosis memories of the ABS actuator and electric unit (control unit).

Are the memories erased?

YES >> INSPECTION END

NO >> Check the items indicated by the self-diagnosis.

FUNCTION DIAGNOSIS

VDC

System Diagram

INFOID:000000003247128

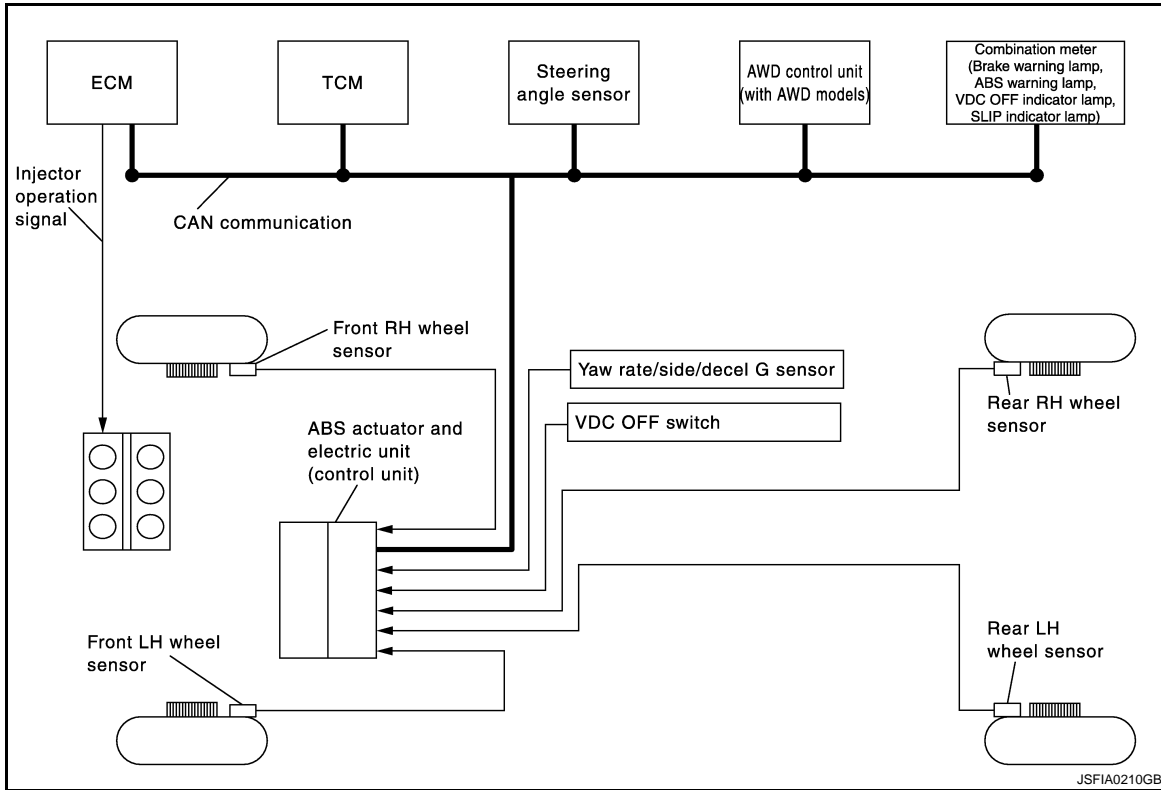

A

B

C

D

E

BRC

G

H

I

J

System Description

INFOID:000000003247129

- In addition to the TCS/ABS function, the driver steering amount and brake operation amount are detected by the steering angle sensor and pressure sensor, and the vehicle's driving status (amount of under steering/over steering) is determined by the information from the yaw rate/side/decel G sensor, wheel sensor, etc., and this information is used to improve vehicle stability by controlling the braking and engine power to all four wheels.
- The SLIP indicator lamp flashes to inform the driver of VDC operation.
- During VDC operation, the body and brake pedal lightly vibrate and mechanical noises may be heard. This is normal.
- The ABS warning lamp, VDC OFF indicator lamp, and SLIP indicator lamp might turn ON when the vehicle is subject to strong shaking or large vibration, such as when the vehicle is on a turn table or a ship while the engine is running or steep slope such as bank. In this case, restart the engine on a normal road, and if the ABS warning lamp, VDC OFF indicator lamp, and SLIP indicator lamp turn OFF, there is no malfunction.

K

L

M

N

Component Parts Location

INFOID:000000003247130

FOR USA

O

P

VDC

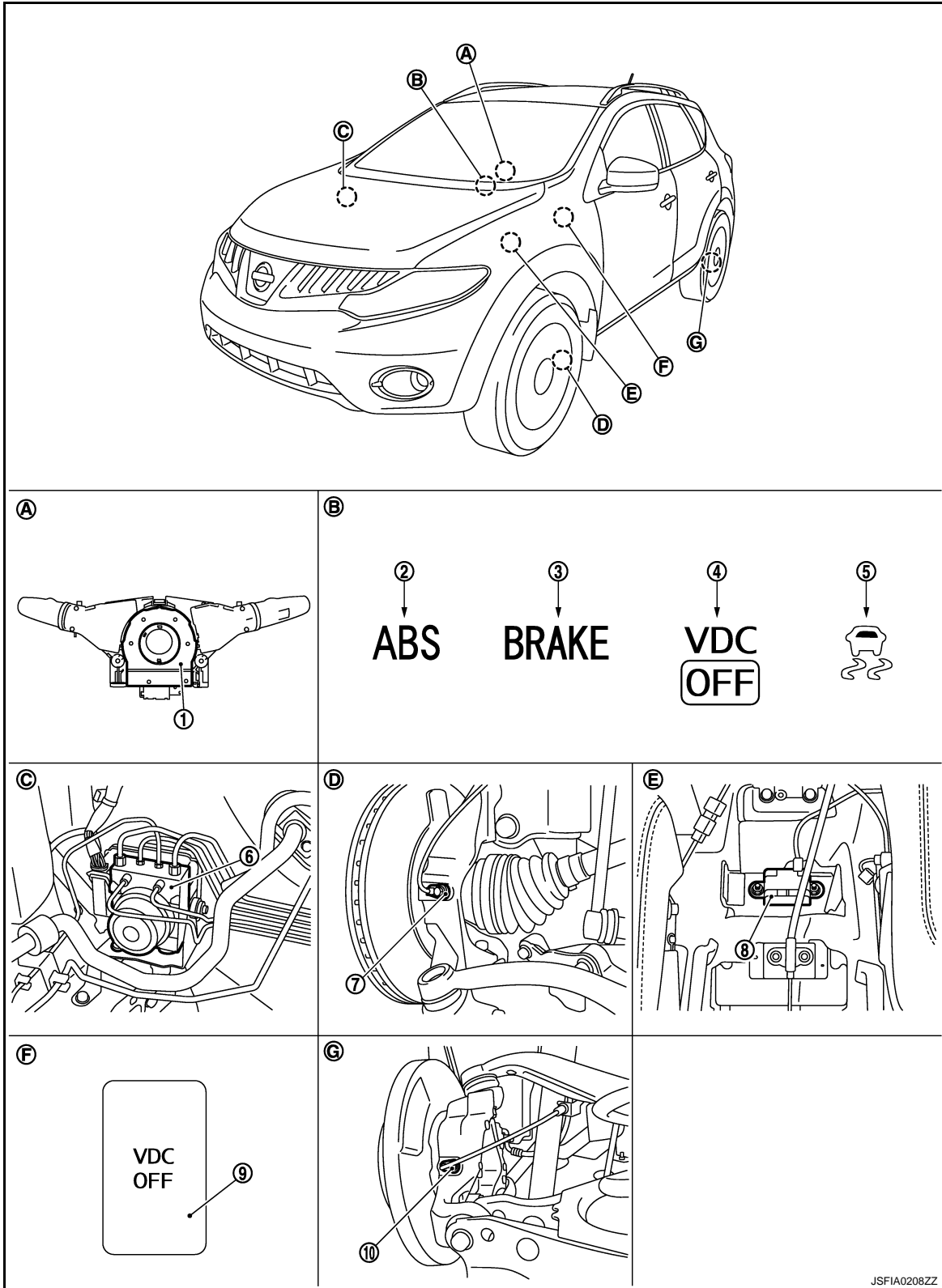

JSFIA0208ZZ

- | | | |
|---------------------------|---------------------------------|--|
| 1. Steering angle sensor | 2. ABS warning lamp | 3. Brake warning lamp |
| 4. VDC OFF indicator lamp | 5. SLIP indicator lamp | 6. ABS actuator and electric unit (control unit) |
| 7. Front wheel sensor | 8. Yaw rate/side/decel G sensor | 9. VDC OFF switch |
| 10. Rear wheel sensor | | |

VDC

< FUNCTION DIAGNOSIS >

[VDC/TCS/ABS]

- A. Back of spiral cable assembly
- B. Combination meter
- C. Engine room (right side)
- D. Steering knuckle
- E. Under center console
- F. Instrument driver lower panel
- G. Rear axle

EXCEPT FOR USA

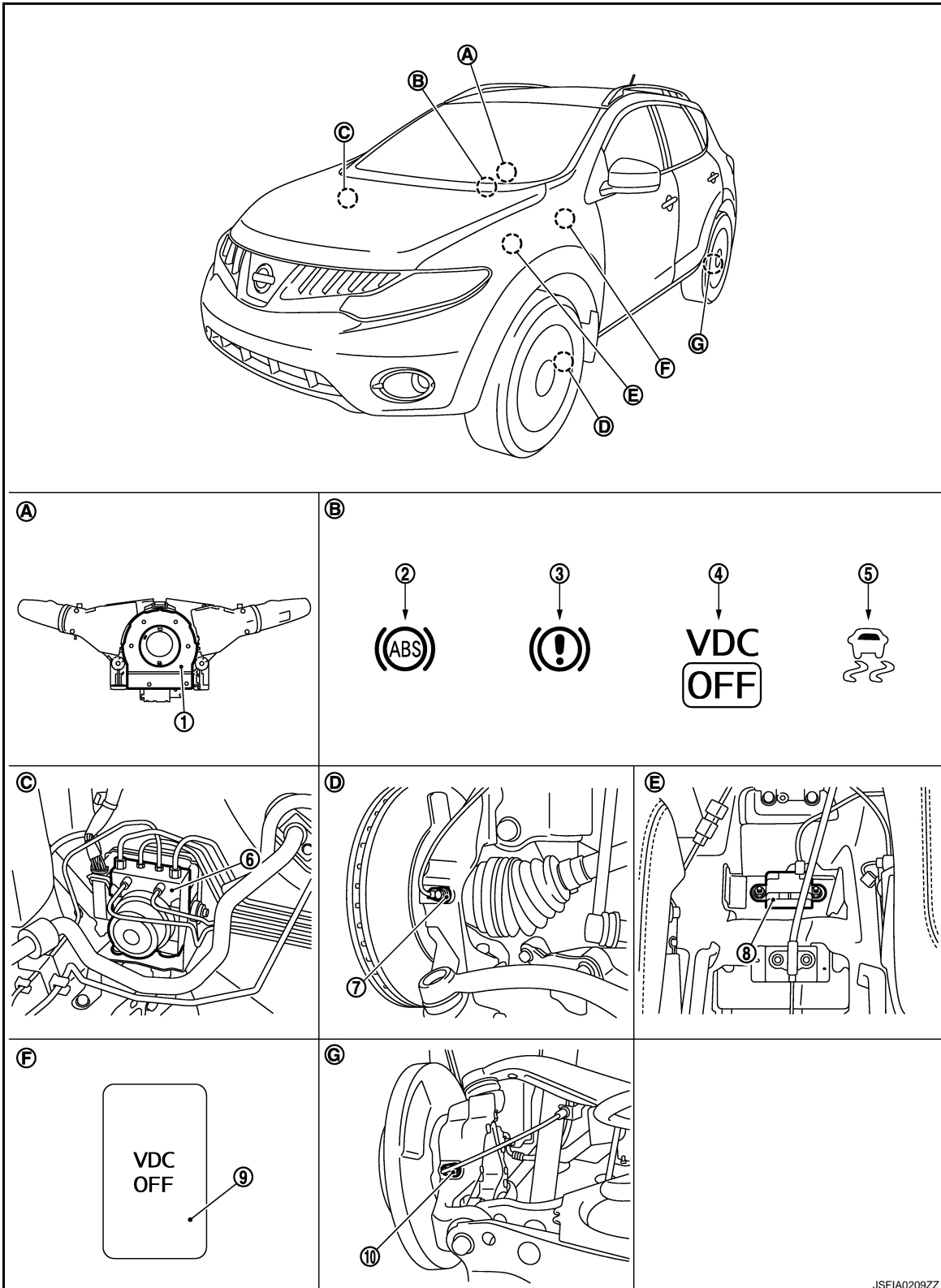

A

B

C

D

E

BRC

G

H

I

J

K

L

M

N

O

P

VDC

< FUNCTION DIAGNOSIS >

[VDC/TCS/ABS]

- | | | |
|----------------------------------|---------------------------------|--|
| 1. Steering angle sensor | 2. ABS warning lamp | 3. Brake warning lamp |
| 4. VDC OFF indicator lamp | 5. SLIP indicator lamp | 6. ABS actuator and electric unit (control unit) |
| 7. Front wheel sensor | 8. Yaw rate/side/decel G sensor | 9. VDC OFF switch |
| 10. Rear wheel sensor | | |
| A. Back of spiral cable assembly | B. Combination meter | C. Engine room (right side) |
| D. Steering knuckle | E. Under center console | F. Instrument driver lower panel |
| G. Rear axle | | |

Component Description

INFOID:000000003247131

Component parts		Reference
ABS actuator and electric unit (control unit)	Pump	BRC-44, "Description"
	Motor	
	Actuator relay (Main relay)	BRC-62, "Description"
	Solenoid valve	BRC-54, "Description"
	VDC switch-over valve (CV1, CV2)	BRC-73, "Description"
	VDC switch-over valve (SV1, SV2)	BRC-75, "Description"
Wheel sensor		BRC-34, "Description"
Yaw rate/side/decel G sensor		BRC-46, "Description"
Steering angle sensor		BRC-66, "Description"
VDC OFF switch		BRC-82, "Description"
ABS warning lamp		BRC-84, "Description"
Brake warning lamp		BRC-85, "Description"
VDC OFF indicator lamp		BRC-86, "Description"
SLIP indicator lamp		BRC-87, "Description"

TCS

System Diagram

INFOID:000000003305333

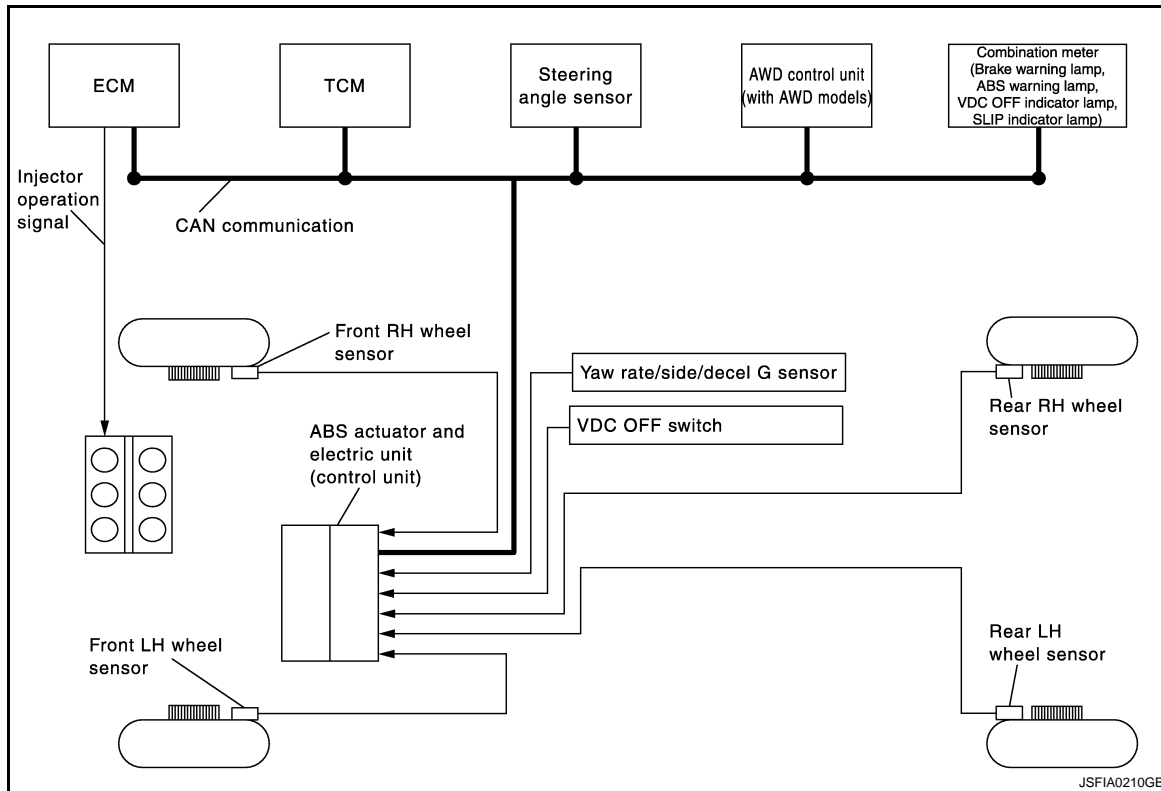

System Description

INFOID:000000003247133

- The wheel spin of the drive wheels is detected by the ABS actuator and electric unit (control unit) using the wheel speed signals from the four wheels, so if wheel spin occurs, the drive wheel right and left brake fluid pressure control and engine fuel cut are conducted while the throttle valve opening is restricted to reduce the engine torque and decrease the amount of wheel spin. In addition, the throttle opening is controlled to achieve the optimum engine torque.
- Depending on road circumstances, the driver may have a sluggish feel. This is normal, because the optimum traction has the highest priority under TCS operation.
- TCS may be activated any time the vehicle suddenly accelerates, depressing accelerator pedal fully, suddenly downshifts, upshifts, or is driven on a road with a varying surface friction coefficient.
- During TCS operation, TCS informs a driver of system operation by flashing SLIP indicator lamp.

Component Parts Location

INFOID:000000003305334

FOR USA

TCS

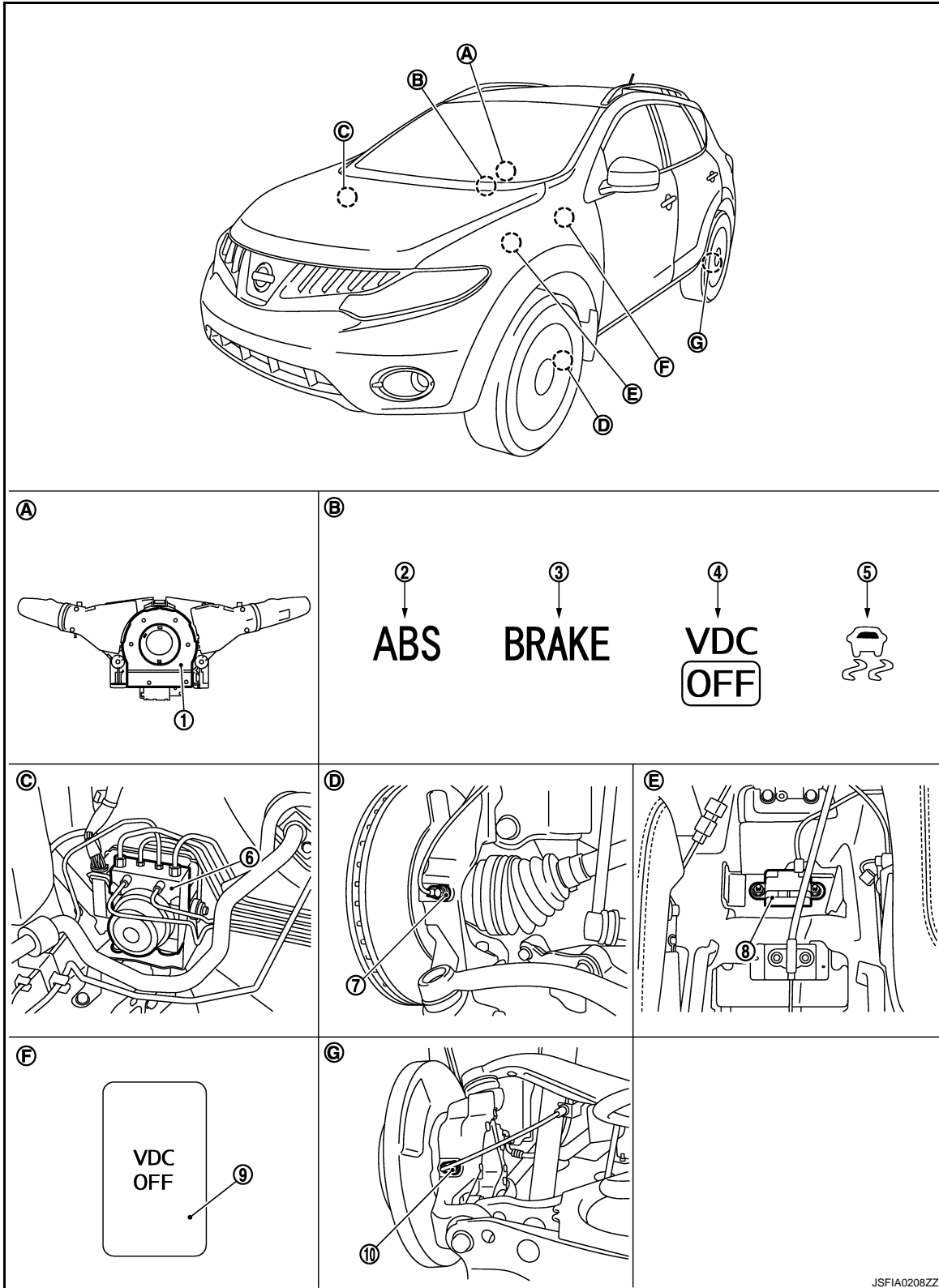

JSFIA0208ZZ

- | | | |
|---------------------------|---------------------------------|--|
| 1. Steering angle sensor | 2. ABS warning lamp | 3. Brake warning lamp |
| 4. VDC OFF indicator lamp | 5. SLIP indicator lamp | 6. ABS actuator and electric unit (control unit) |
| 7. Front wheel sensor | 8. Yaw rate/side/decel G sensor | 9. VDC OFF switch |
| 10. Rear wheel sensor | | |

TCS

[VDC/TCS/ABS]

< FUNCTION DIAGNOSIS >

- A. Back of spiral cable assembly
- B. Combination meter
- C. Engine room (right side)
- D. Steering knuckle
- E. Under center console
- F. Instrument driver lower panel
- G. Rear axle

EXCEPT FOR USA

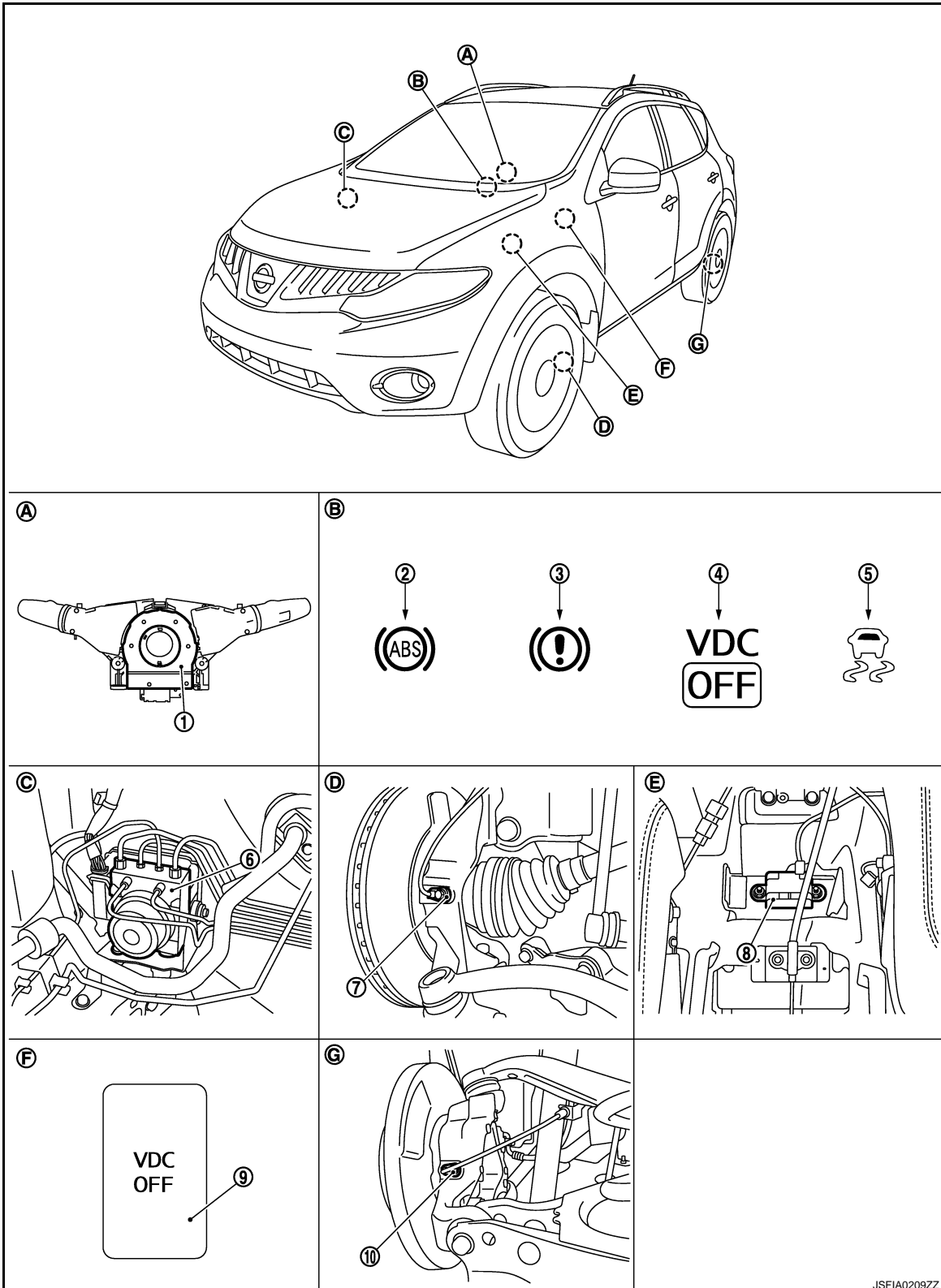

A
B
C
D
E
BRC
G
H
I
J
K
L
M
N
O
P

TCS

[VDC/TCS/ABS]

< FUNCTION DIAGNOSIS >

- | | | |
|----------------------------------|---------------------------------|--|
| 1. Steering angle sensor | 2. ABS warning lamp | 3. Brake warning lamp |
| 4. VDC OFF indicator lamp | 5. SLIP indicator lamp | 6. ABS actuator and electric unit (control unit) |
| 7. Front wheel sensor | 8. Yaw rate/side/decel G sensor | 9. VDC OFF switch |
| 10. Rear wheel sensor | | |
| A. Back of spiral cable assembly | B. Combination meter | C. Engine room (right side) |
| D. Steering knuckle | E. Under center console | F. Instrument driver lower panel |
| G. Rear axle | | |

Component Description

INFOID:000000003305335

Component parts		Reference
ABS actuator and electric unit (control unit)	Pump	BRC-44, "Description"
	Motor	
	Actuator relay (Main relay)	BRC-62, "Description"
	Solenoid valve	BRC-54, "Description"
	VDC switch-over valve (CV1, CV2)	BRC-73, "Description"
	VDC switch-over valve (SV1, SV2)	BRC-75, "Description"
Wheel sensor		BRC-34, "Description"
Yaw rate/side/decel G sensor		BRC-46, "Description"
Steering angle sensor		BRC-66, "Description"
VDC OFF switch		BRC-82, "Description"
ABS warning lamp		BRC-84, "Description"
Brake warning lamp		BRC-85, "Description"
VDC OFF indicator lamp		BRC-86, "Description"
SLIP indicator lamp		BRC-87, "Description"

ABS

System Diagram

INFOID:000000003305336

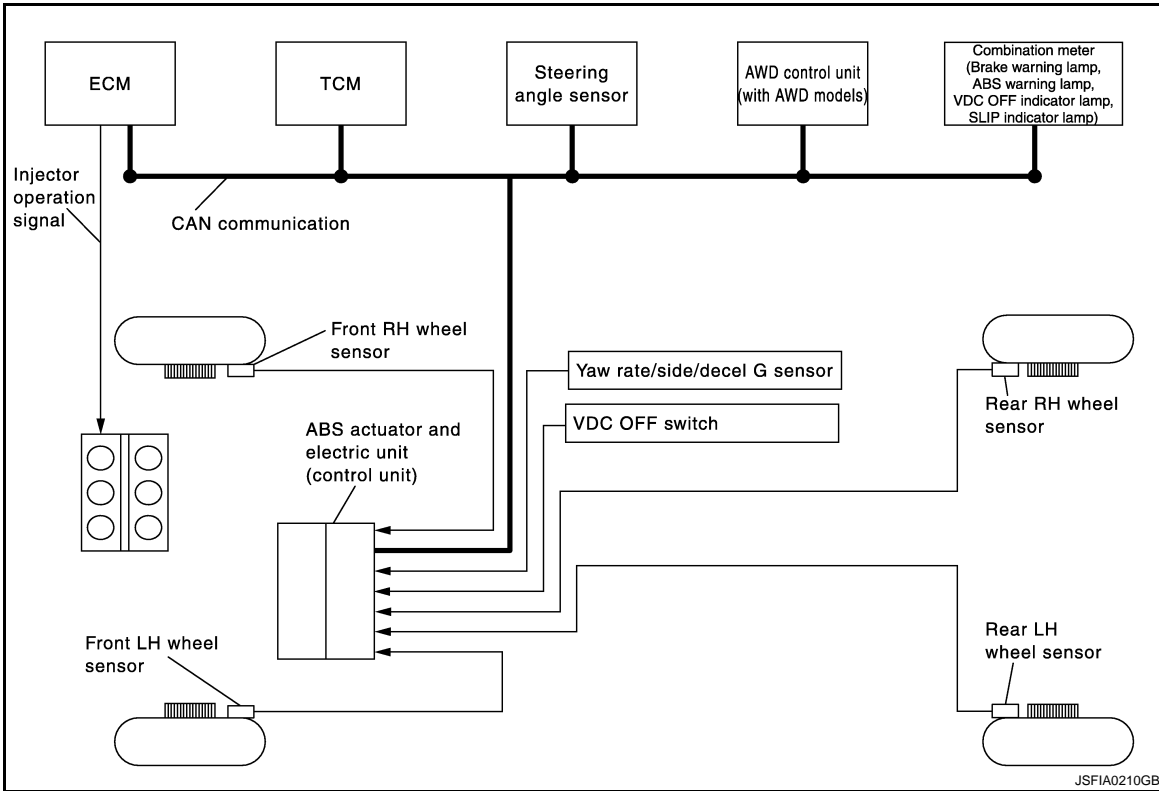

A

B

C

D

E

BRC

G

H

I

System Description

INFOID:000000003247137

- The Anti-Lock Braking System detects wheel revolution while braking, and it improves handling stability during sudden braking by electrically preventing 4 wheel lock. Maneuverability is also improved for avoiding obstacles.
- If the electrical system malfunction, then fail-safe function is activated, ABS becomes inoperative, and ABS warning lamp turns ON.
- Electrical system diagnosis by CONSULT-III is available.
- During ABS operation, brake pedal lightly vibrates and a mechanical noise may be heard. This is normal.
- Just after starting the vehicle after the ignition switch ON, brake pedal may vibrate or motor operating noise may be heard from engine component. This is a normal status of operation check.
- Stopping distance may be longer than that of vehicles without ABS when vehicle drives on rough, gravel, or snow-covered (fresh, deep snow) roads.

J

K

L

M

Component Parts Location

INFOID:000000003305337

FOR USA

N

O

P

ABS

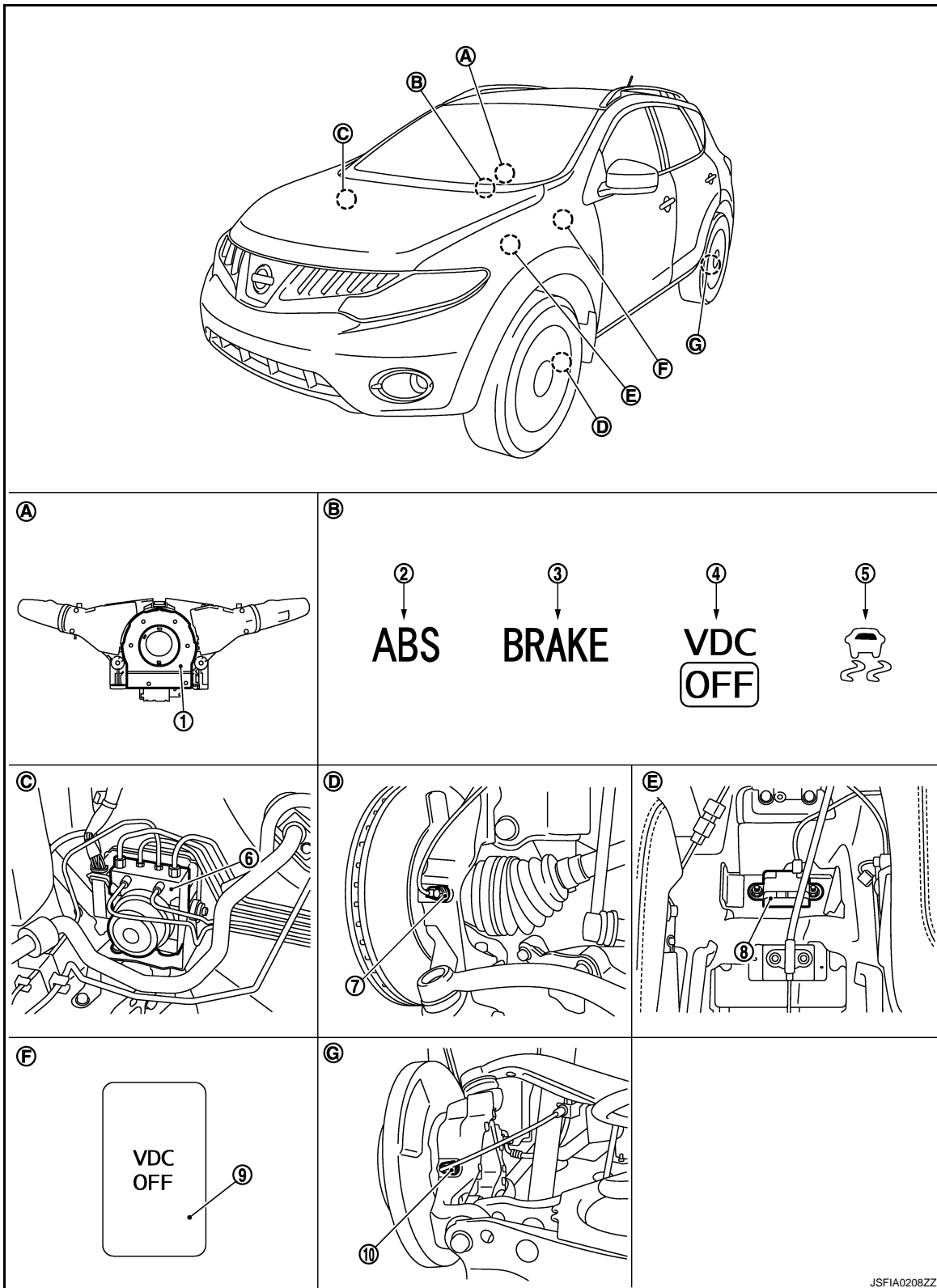

JSFIA0208ZZ

- | | | |
|---------------------------|---------------------------------|--|
| 1. Steering angle sensor | 2. ABS warning lamp | 3. Brake warning lamp |
| 4. VDC OFF indicator lamp | 5. SLIP indicator lamp | 6. ABS actuator and electric unit (control unit) |
| 7. Front wheel sensor | 8. Yaw rate/side/decel G sensor | 9. VDC OFF switch |
| 10. Rear wheel sensor | | |

ABS

[VDC/TCS/ABS]

< FUNCTION DIAGNOSIS >

- A. Back of spiral cable assembly
- B. Combination meter
- C. Engine room (right side)
- D. Steering knuckle
- E. Under center console
- F. Instrument driver lower panel
- G. Rear axle

EXCEPT FOR USA

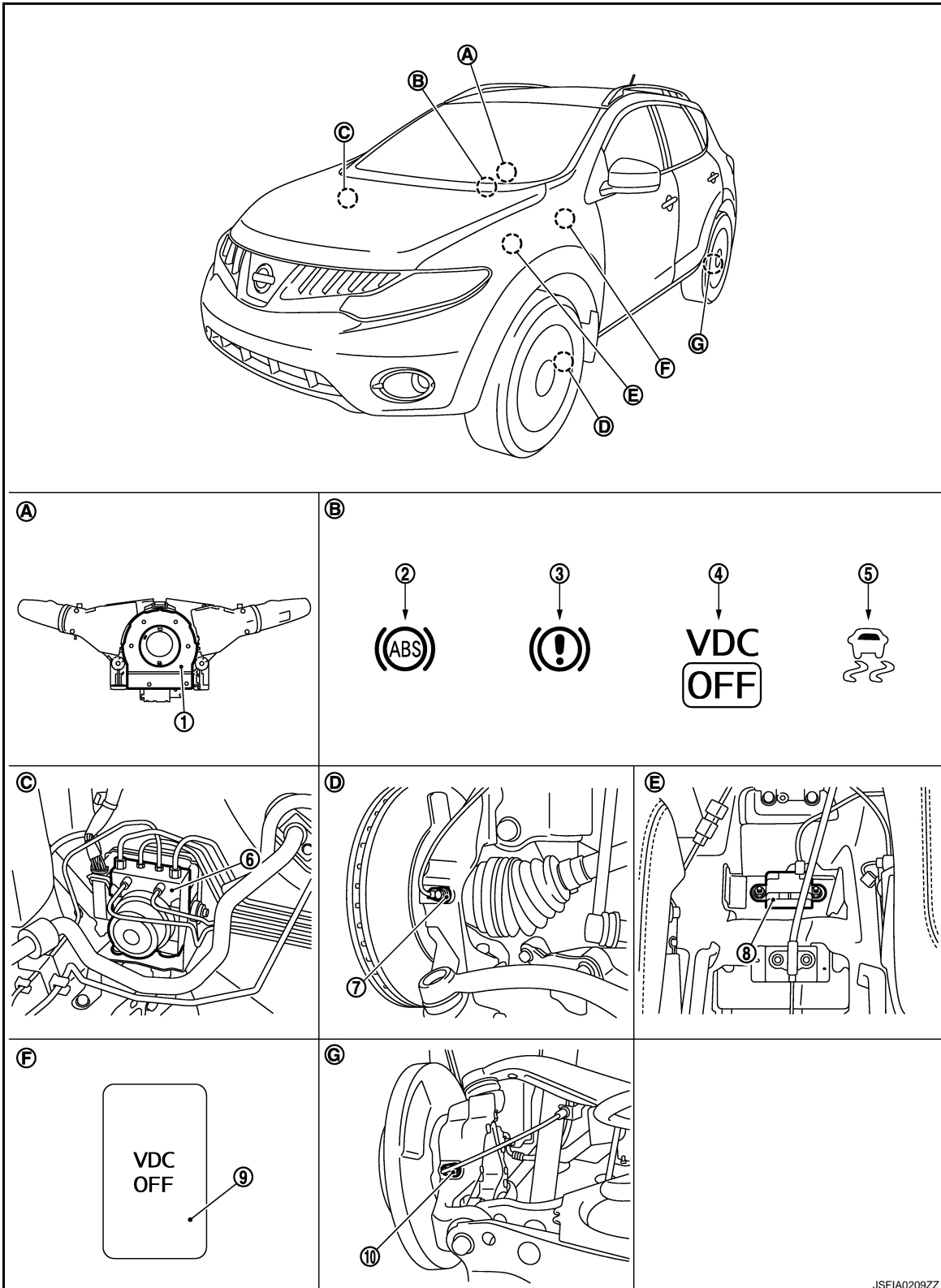

A

B

C

D

E

BRC

G

H

I

J

K

L

M

N

O

P

ABS

< FUNCTION DIAGNOSIS >

[VDC/TCS/ABS]

- | | | |
|----------------------------------|---------------------------------|--|
| 1. Steering angle sensor | 2. ABS warning lamp | 3. Brake warning lamp |
| 4. VDC OFF indicator lamp | 5. SLIP indicator lamp | 6. ABS actuator and electric unit (control unit) |
| 7. Front wheel sensor | 8. Yaw rate/side/decel G sensor | 9. VDC OFF switch |
| 10. Rear wheel sensor | | |
| A. Back of spiral cable assembly | B. Combination meter | C. Engine room (right side) |
| D. Steering knuckle | E. Under center console | F. Instrument driver lower panel |
| G. Rear axle | | |

Component Description

INFOID:000000003305338

Component parts	Reference	
ABS actuator and electric unit (control unit)	Pump	BRC-44, "Description"
	Motor	
	Actuator relay (Main relay)	BRC-62, "Description"
	Solenoid valve	BRC-54, "Description"
	VDC switch-over valve (CV1, CV2)	BRC-73, "Description"
	VDC switch-over valve (SV1, SV2)	BRC-75, "Description"
Wheel sensor	BRC-34, "Description"	
Yaw rate/side/decel G sensor	BRC-46, "Description"	
Steering angle sensor	BRC-66, "Description"	
VDC OFF switch	BRC-82, "Description"	
ABS warning lamp	BRC-84, "Description"	
Brake warning lamp	BRC-85, "Description"	
VDC OFF indicator lamp	BRC-86, "Description"	
SLIP indicator lamp	BRC-87, "Description"	

EBD

System Diagram

INFOID:000000003305339

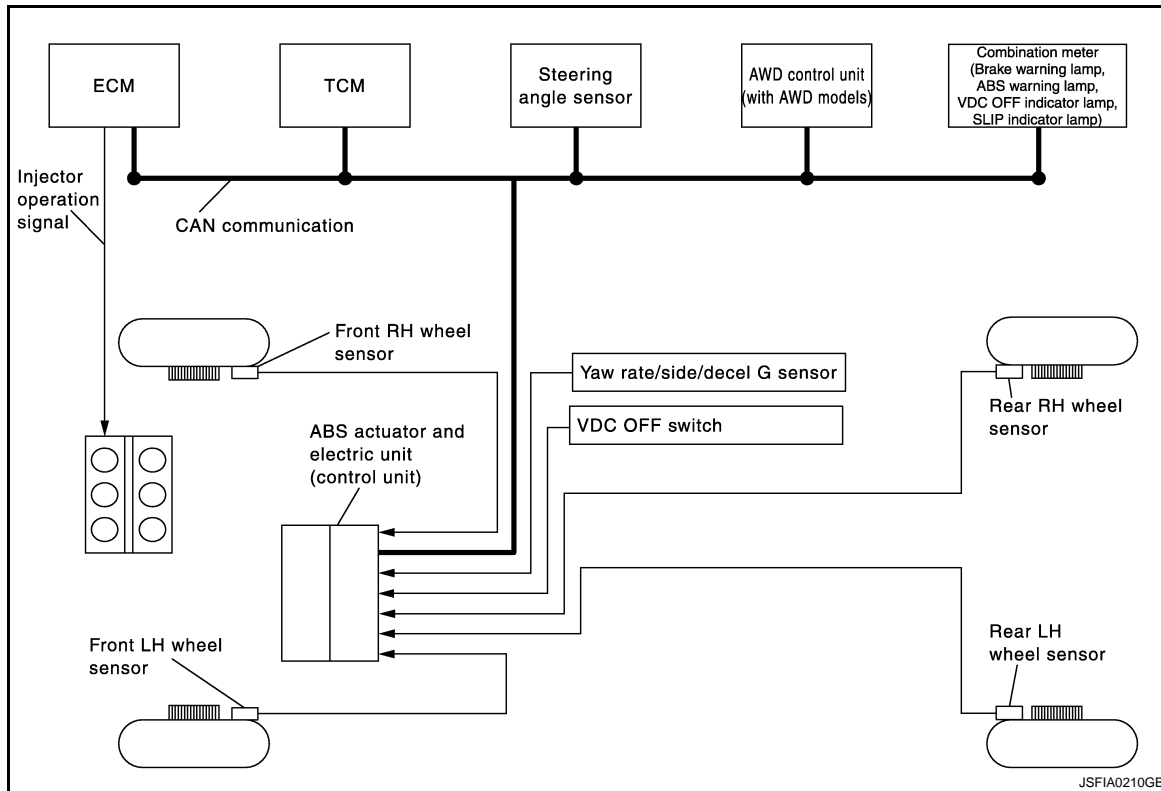

System Description

INFOID:000000003247141

- Electronic Brake force Distribution detects subtle slippages between front and rear wheels during braking, and it improves handling stability by electronically controlling brake fluid pressure which results in reduced rear wheel slippage.
- If the electrical system malfunction, fail-safe function is activated, EBD and ABS becomes inoperative, and ABS warning lamp and brake warning lamp are turned ON.
- Electrical system diagnosis by CONSULT-III is available.
- During EBD operation, brake pedal lightly vibrates and a mechanical noise may be heard. This is normal.
- Just after starting the vehicle after the ignition switch ON, brake pedal may vibrate or motor operating noise may be heard from engine compartment. This is a normal status of operation check.
- Stopping distance may be longer than that of vehicles without EBD when vehicle drives on rough, gravel, or snow-covered (fresh, deep snow) roads.

Component Parts Location

INFOID:000000003305340

FOR USA

EBD

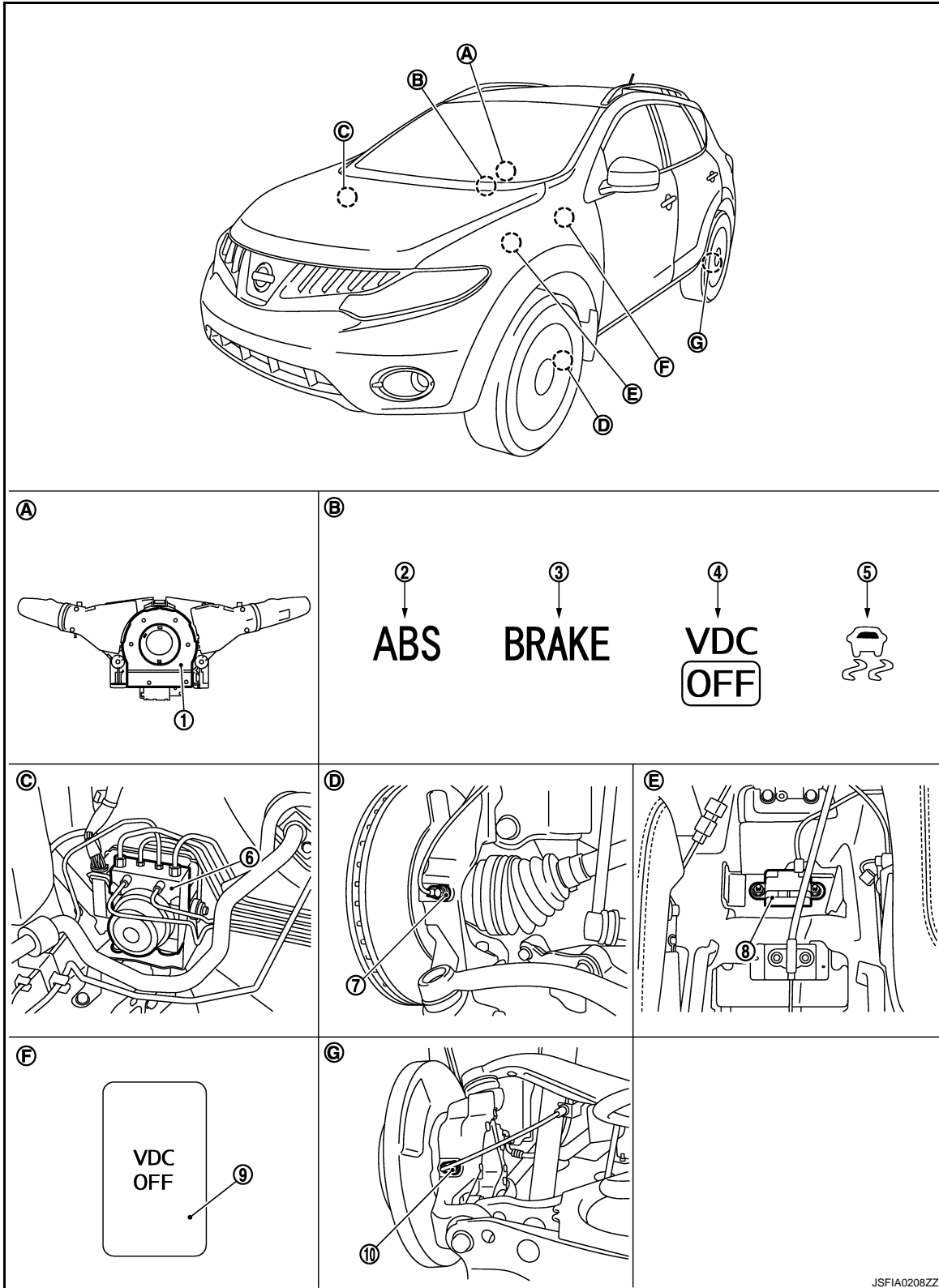

JSFIA0208ZZ

- | | | |
|---------------------------|---------------------------------|--|
| 1. Steering angle sensor | 2. ABS warning lamp | 3. Brake warning lamp |
| 4. VDC OFF indicator lamp | 5. SLIP indicator lamp | 6. ABS actuator and electric unit (control unit) |
| 7. Front wheel sensor | 8. Yaw rate/side/decel G sensor | 9. VDC OFF switch |
| 10. Rear wheel sensor | | |

EBD

< FUNCTION DIAGNOSIS >

[VDC/TCS/ABS]

- A. Back of spiral cable assembly
- B. Combination meter
- C. Engine room (right side)
- D. Steering knuckle
- E. Under center console
- F. Instrument driver lower panel
- G. Rear axle

EXCEPT FOR USA

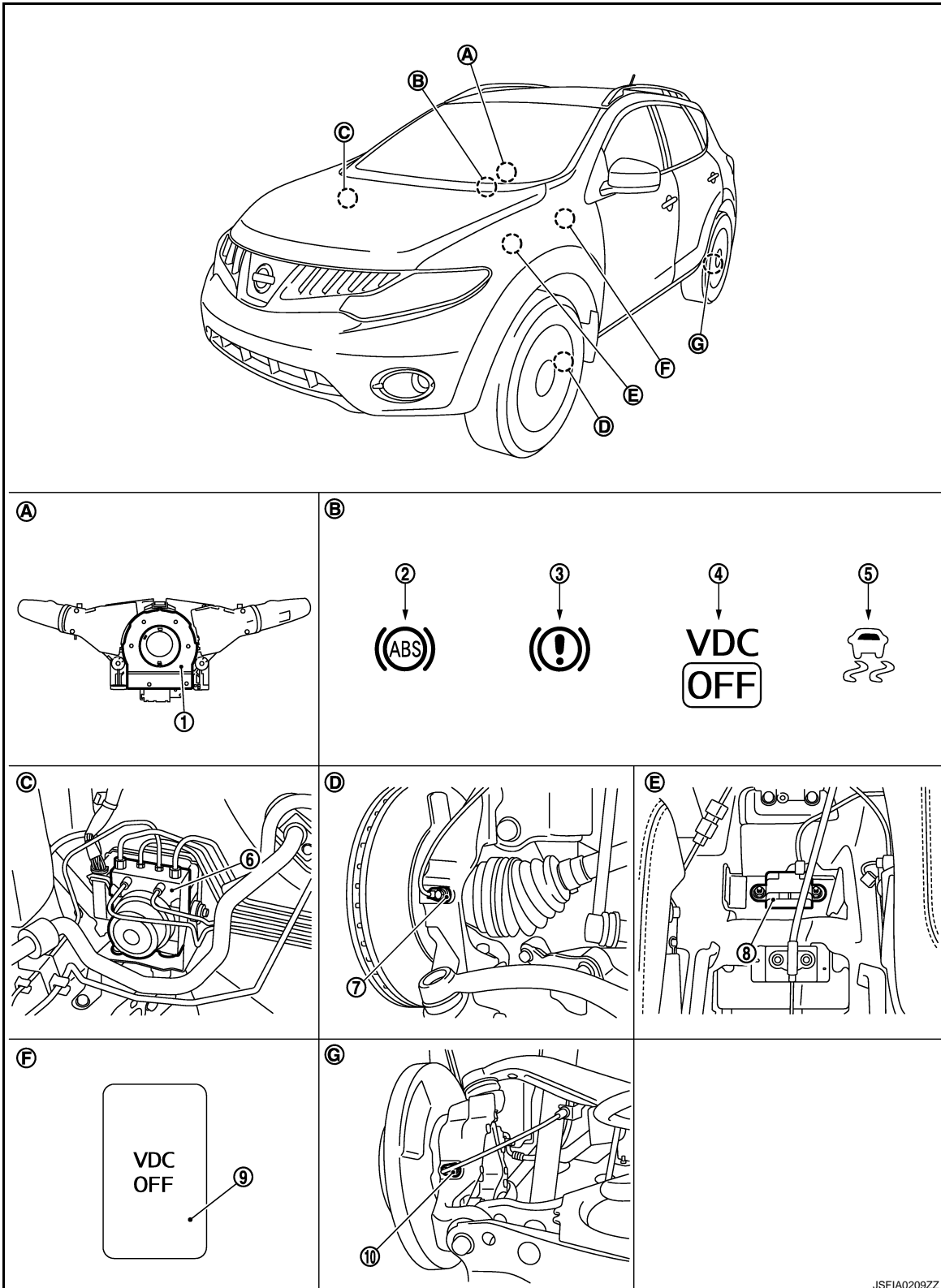

A

B

C

D

E

BRC

G

H

I

J

K

L

M

N

O

P

< FUNCTION DIAGNOSIS >

- | | | |
|----------------------------------|---------------------------------|--|
| 1. Steering angle sensor | 2. ABS warning lamp | 3. Brake warning lamp |
| 4. VDC OFF indicator lamp | 5. SLIP indicator lamp | 6. ABS actuator and electric unit (control unit) |
| 7. Front wheel sensor | 8. Yaw rate/side/decel G sensor | 9. VDC OFF switch |
| 10. Rear wheel sensor | | |
| A. Back of spiral cable assembly | B. Combination meter | C. Engine room (right side) |
| D. Steering knuckle | E. Under center console | F. Instrument driver lower panel |
| G. Rear axle | | |

Component Description

INFOID:000000003305341

Component parts		Reference
ABS actuator and electric unit (control unit)	Pump	BRC-44, "Description"
	Motor	
	Actuator relay (Main relay)	BRC-62, "Description"
	Solenoid valve	BRC-54, "Description"
	VDC switch-over valve (CV1, CV2)	BRC-73, "Description"
	VDC switch-over valve (SV1, SV2)	BRC-75, "Description"
Wheel sensor		BRC-34, "Description"
Yaw rate/side/decel G sensor		BRC-46, "Description"
Steering angle sensor		BRC-66, "Description"
VDC OFF switch		BRC-82, "Description"
ABS warning lamp		BRC-84, "Description"
Brake warning lamp		BRC-85, "Description"
VDC OFF indicator lamp		BRC-86, "Description"
SLIP indicator lamp		BRC-87, "Description"

DIAGNOSIS SYSTEM [ABS ACTUATOR AND ELECTRIC UNIT (CONTROL UNIT)]

< FUNCTION DIAGNOSIS >

[VDC/TCS/ABS]

DIAGNOSIS SYSTEM [ABS ACTUATOR AND ELECTRIC UNIT (CONTROL UNIT)]

CONSULT-III Function

INFOID:000000003247144

FUNCTION

CONSULT-III can display each diagnostic item using the diagnostic test modes as following.

Diagnostic test mode	Function
Work support	This mode enables a technician to adjust some devices faster and more accurately by following the indications on CONSULT-III.
Self diagnostic results	Self-diagnostic results can be read and erased quickly.
Data monitor	Input/Output data in the ABS actuator and electric unit (control unit) can be read.
Active test	CONSULT-III drives some actuators apart from the ABS actuator and electric unit (control unit) and also shifts some parameters in a specified range.
ECU part number	ABS actuator and electric unit (control unit) part number can be read.

WORK SUPPORT

Item	Description
ST ANGLE SENSOR ADJUSTMENT	Adjusts the neutral position of the steering angle sensor.
DECEL G SEN CALIBRATION	Calibrates yaw rate/side/decel G sensor.
PRESS SEN CALIBRATION	Calibrates pressure sensor.

SELF-DIAGNOSTIC RESULT

Operation Procedure

Before performing the self-diagnosis, start the engine and drive the vehicle at 30 km/h (19 MPH) or more for approximately 1 minute.

Display Item List

Refer to [BRC-102, "DTC No. Index"](#).

How to Erase Self-diagnosis Results

After erasing DTC memory, start the engine and drive the vehicle at 30 km/h (19 MPH) or more for approximately 1 minute as the final inspection, and make sure that the ABS warning lamp, VDC OFF indicator lamp, SLIP indicator lamp and brake warning lamp turn OFF.

CAUTION:

If memory cannot be erased, perform applicable diagnosis.

NOTE:

- When the wheel sensor malfunctions, after inspecting the wheel sensor system, the ABS warning lamp, VDC OFF indicator lamp, SLIP indicator lamp and brake warning lamp will not turn OFF even when the system is normal unless the vehicle is driving at approximately 30 km/h (19 MPH) or more for approximately 1 minute.
- Brake warning lamp will turn ON in case of parking brake operation (when switch is ON) or of brake fluid level switch operation (when brake fluid is insufficient).
- VDC OFF switch should not stay "ON" position.

DATA MONITOR

Display Item List

DIAGNOSIS SYSTEM [ABS ACTUATOR AND ELECTRIC UNIT (CONTROL UNIT)]

< FUNCTION DIAGNOSIS >

[VDC/TCS/ABS]

×: Applicable ▼: Optional item

Monitor item (Unit)	SELECT MONITOR ITEM		Remarks
	ECU INPUT SIGNALS	MAIN SIGNALS	
FR LH SENSOR [km/h (MPH)]	×	×	Wheel speed
FR RH SENSOR [km/h (MPH)]	×	×	
RR LH SENSOR [km/h (MPH)]	×	×	
RR RH SENSOR [km/h (MPH)]	×	×	
STOP LAMP SW (On/Off)	×	×	Stop lamp switch signal status
BATTERY VOLT (V)	×	×	Battery voltage supplied to the ABS actuator and electric unit (control unit)
SLCT LVR POSI	×	×	Shift position judged by shift position signal
OFF SW (On/Off)	×	×	VDC OFF switch
YAW RATE SEN (d/s)	×	×	Yaw rate detected by yaw rate/side/decel G sensor
DECEL G-SEN (G)	×	×	Decel G detected by yaw rate/side/decel G sensor
ACCEL POS SIG (%)	×	▼	Throttle actuator opening/closing is displayed (Linked with accelerator pedal)
SIDE G-SENSOR (m/s ²)	×	▼	Transverse G detected by yaw rate/side/decel G sensor
STR ANGLE SIG (°)	×	▼	Steering angle detected by steering angle sensor
ENGINE RPM [tr/min (rpm)]	×	▼	Engine speed
PRESS SENSOR (bar)	×	▼	Brake fluid pressure detected by pressure sensor
FR RH IN SOL (On/Off)	▼	×	Operation status of each solenoid valve
FR RH OUT SOL (On/Off)	▼	×	
FR LH IN SOL (On/Off)	▼	×	
FR LH OUT SOL (On/Off)	▼	×	
RR RH IN SOL (On/Off)	▼	×	
RR RH OUT SOL (On/Off)	▼	×	
RR LH IN SOL (On/Off)	▼	×	
RR LH OUT SOL (On/Off)	▼	×	
MOTOR RELAY (On/Off)	▼	×	Motor and motor relay operation
ACTUATOR RLY (On/Off)	▼	×	Actuator relay operation

DIAGNOSIS SYSTEM [ABS ACTUATOR AND ELECTRIC UNIT (CONTROL UNIT)]

< FUNCTION DIAGNOSIS >

[VDC/TCS/ABS]

Monitor item (Unit)	SELECT MONITOR ITEM		Remarks	
	ECU INPUT SIGNALS	MAIN SIGNALS		
ABS WARN LAMP (On/Off)	▼	×	ABS warning lamp	A
OFF LAMP (On/Off)	▼	×	VDC OFF indicator lamp	B
SLIP LAMP (On/Off)	▼	×	SLIP indicator lamp	C
CV1 (On/Off)	▼	▼	Cut valve 1 monitor	D
CV2 (On/Off)	▼	▼	Cut valve 2 monitor	E
SV1 (On/Off)	▼	▼	Suction valve 1 monitor	E
SV2 (On/Off)	▼	▼	Suction valve 2 monitor	BRC
EBD SIGNAL (On/Off)	▼	▼	EBD operation	
ABS SIGNAL (On/Off)	▼	▼	ABS operation	G
TCS SIGNAL (On/Off)	▼	▼	TCS operation	H
VDC SIGNAL (On/Off)	▼	▼	VDC operation	
EBD FAIL SIG (On/Off)	▼	▼	EBD fail-safe status	I
ABS FAIL SIG (On/Off)	▼	▼	ABS fail-safe status	J
TCS FAIL SIG (On/Off)	▼	▼	TCS fail-safe status	
VDC FAIL SIG (On/Off)	▼	▼	VDC fail-safe status	K
EBD WARN LAMP (On/Off)	▼	▼	Brake warning lamp	L
4WD FAIL REQ (On/Off)	▼	▼	AWD fail-safe signal status	
2WD/4WD (2WD/4WD)	▼	▼	Distinguish 2WD and AWD	M

ACTIVE TEST MODE

CAUTION:

- Do not perform active test while driving vehicle.
- Make sure to completely bleed air from brake system.
- The active test cannot be started when the ABS warning lamp is ON.
- ABS warning lamp and brake warning lamp are ON during active test.

NOTE:

- When active test is performed while depressing the pedal, the pedal depression amount will change. This is normal. (Only solenoid valve and ABS motor.)
- “TEST IS STOPPED” is displayed 10 seconds after operation start.
- After “TEST IS STOPPED” is displayed, to perform test again.

Test Item

ABS SOLENOID VALVE

- For ABS solenoid valve, touch “Up”, “Keep” and “Down”. Then use screen monitor to check that solenoid valve operates as shown in the table below.

DIAGNOSIS SYSTEM [ABS ACTUATOR AND ELECTRIC UNIT (CONTROL UNIT)]

< FUNCTION DIAGNOSIS >

[VDC/TCS/ABS]

Test item	Display item	Display		
		Up	Keep	Down
FR RH SOL	FR RH IN SOL	Off	On	On
	FR RH OUT SOL	Off	Off	On*
	CV1	Off	Off	Off
	SV1	Off	Off	Off
FR LH SOL	FR LH IN SOL	Off	On	On
	FR LH OUT SOL	Off	Off	On*
	CV2	Off	Off	Off
	SV2	Off	Off	Off
RR RH SOL	RR RH IN SOL	Off	On	On
	RR RH OUT SOL	Off	Off	On*
	CV2	Off	Off	Off
	SV2	Off	Off	Off
RR LH SOL	RR LH IN SOL	Off	On	On
	RR LH OUT SOL	Off	Off	On*
	CV1	Off	Off	Off
	SV1	Off	Off	Off

*: On for 1 to 2 seconds after the touch, and then Off.

ABS SOLENOID VALVE (ACT)

- For ABS solenoid valve (ACT), touch “Up”, “ACT UP” and “ACT KEEP”. Then use screen monitor to check that solenoid valve operates as shown in the table below.

Test item	Display item	Display		
		Up	ACT UP	ACT KEEP
FR RH ABS SOLENOID (ACT)	FR RH IN SOL	Off	Off	Off
	FR RH OUT SOL	Off	Off	Off
	CV1	Off	On	On
	SV1	Off	On*	Off
FR LH ABS SOLENOID (ACT)	FR LH IN SOL	Off	Off	Off
	FR LH OUT SOL	Off	Off	Off
	CV2	Off	On	On
	SV2	Off	On*	Off
RR RH ABS SOLENOID (ACT)	RR RH IN SOL	Off	Off	Off
	RR RH OUT SOL	Off	Off	Off
	CV2	Off	On	On
	SV2	Off	On*	Off
RR LH ABS SOLENOID (ACT)	RR LH IN SOL	Off	Off	Off
	RR LH OUT SOL	Off	Off	Off
	CV1	Off	On	On
	SV1	Off	On*	Off

*: On for 1 to 2 seconds after the touch, and then Off.

ABS MOTOR

- Touch “On” and “Off” on screen. Make sure motor relay and actuator relay operates as shown in table below.

DIAGNOSIS SYSTEM [ABS ACTUATOR AND ELECTRIC UNIT (CONTROL UNIT)]

< FUNCTION DIAGNOSIS >

[VDC/TCS/ABS]

Test item	Display item	Display	
		On	Off
ABS MOTOR	MOTOR RELAY	On	Off
	ACTUATOR RLY	On	On

ECU PART NUMBER

ABS actuator and electric unit (control unit) part number can be read.

A
B
C
D
E
G
H
I
J
K
L
M
N
O
P

BRC

C1101, C1102, C1103, C1104 WHEEL SENSOR

< COMPONENT DIAGNOSIS >

[VDC/TCS/ABS]

COMPONENT DIAGNOSIS

C1101, C1102, C1103, C1104 WHEEL SENSOR

Description

INFOID:000000003247145

When the sensor rotor rotates, the magnetic field changes. It converts the magnetic field changes to current signals (rectangular wave) and transmits them to the ABS actuator and electric unit (control unit).

DTC Logic

INFOID:000000003247146

DTC DETECTION LOGIC

DTC	Display item	Malfunction detected condition	Possible cause
C1101	RR RH SENSOR-1	Circuit of rear RH wheel sensor is open or short circuit. Current signal from sensor is outside limits.	<ul style="list-style-type: none">• Harness or connector• Wheel sensor• ABS actuator and electric unit (control unit)
C1102	RR LH SENSOR-1	Circuit of rear LH wheel sensor is open or short circuit. Current signal from sensor is outside limits.	
C1103	FR RH SENSOR-1	Circuit of front RH wheel sensor is open or short circuit. Current signal from sensor is outside limits.	
C1104	FR LH SENSOR-1	Circuit of front LH wheel sensor is open or short circuit. Current signal from sensor is outside limits.	

DTC CONFIRMATION PROCEDURE

1. DTC REPRODUCTION PROCEDURE

1. Start the engine and drive the vehicle at 30 km/h (19 MPH) or more for approximately 1 minute.
2. Perform ABS actuator and electric unit (control unit) self-diagnosis.

Is DTC "C1101", "C1102", "C1103" or "C1104" detected?

- YES >> Proceed to diagnosis procedure. Refer to [BRC-34, "Diagnosis Procedure"](#).
NO >> INSPECTION END

Diagnosis Procedure

INFOID:000000003247147

CAUTION:

- Do not measure the resistance value and also voltage between sensor terminals with tester etc., because the sensors are active sensors.
- Do not expand terminal of connector with a tester terminal stick, when it does the inspection with the tester.

1. CHECK TIRE

Check air pressure, wear, and size. Refer to [WT-111, "Tire Air Pressure"](#).

Is the inspection result normal?

- YES >> GO TO 2.
NO >> Repair or replace damaged parts.

2. CHECK SENSOR AND SENSOR ROTOR

- Check that there is no damage or adherence of foreign matter on the sensor rotor surface.
- Check sensor rotor for damage.
- Check wheel sensor for damage, disconnection or looseness.
- Check that there is no deformation on the wheel sensor mounting surface.

Is the inspection result normal?

- YES >> GO TO 3.
NO >> Repair wheel sensor mount or replace sensor rotor. Then perform the self-diagnosis.

3. CHECK CONNECTOR

1. Turn the ignition switch OFF.
2. Disconnect ABS actuator and electric unit (control unit) connector.
3. Disconnect malfunctioning wheel sensor connector.

C1101, C1102, C1103, C1104 WHEEL SENSOR

[VDC/TCS/ABS]

< COMPONENT DIAGNOSIS >

4. Check terminal to see if it is deformed, disconnected, loose, etc.

Is the inspection result normal?

YES >> GO TO 4.

NO >> Repair or replace damaged parts.

4.CHECK WHEEL SENSOR HARNESS

1. Check the continuity between ABS actuator and electric unit (control unit) harness connector and wheel sensor harness connector. (Also check continuity when steering wheel is turned right and left and when sensor harness inside the wheel house is moved.)

Measurement terminal for signal circuit

ABS actuator and electric unit (control unit)		Wheel sensor			Continuity
Connector	Terminal	Connector	Terminal		
E36	6	E39 (Front RH)		4	Existed
	8	E22 (Front LH)		2	
	12	C4 (2WD models) C6 (AWD models)	(Rear RH)	8	
	2	C3 (2WD models) C5 (AWD models)	(Rear LH)	6	

Measurement terminal for power supply circuit

ABS actuator and electric unit (control unit)		Wheel sensor			Continuity
Connector	Terminal	Connector	Terminal		
E36	5	E39 (Front RH)		3	Existed
	9	E22 (Front LH)		1	
	11	C4 (2WD models) C6 (AWD models)	(Rear RH)	7	
	3	C3 (2WD models) C5 (AWD models)	(Rear LH)	5	

2. Check the continuity between ABS actuator and electric unit (control unit) harness connector.

ABS actuator and electric unit (control unit)				Continuity
Connector	Terminal	Connector	Terminal	
E36	6, 5	E36	13, 26	Not existed
	8, 9			
	12, 11			
	2, 3			

Is the inspection result normal?

YES >> GO TO 5.

NO >> Repair or replace damaged parts.

5.CHECK WHEEL SENSOR POWER SUPPLY CIRCUIT

1. Connect ABS actuator and electric unit (control unit) connector.
2. Turn the ignition switch ON.
CAUTION:
Never start the engine.
3. Check the voltage between wheel sensor harness connector and ground.

C1101, C1102, C1103, C1104 WHEEL SENSOR

< COMPONENT DIAGNOSIS >

[VDC/TCS/ABS]

Wheel sensor			—	Voltage
Connector	Terminal			
E39 (Front RH)		3	Ground	Approx. 8 V or more
E22 (Front LH)		1		
C4 (2WD models) C6 (AWD models)	(Rear RH)	7		
C3 (2WD models) C5 (AWD models)	(Rear LH)	5		

Is the inspection result normal?

YES >> GO TO 6.

NO >> Repair or replace damaged parts.

6.CHECK DATA MONITOR

1. Turn the ignition switch OFF.
2. Connect each wheel sensor connector.
3. Check wheel sensor signal. Refer to [BRC-36. "Component Inspection"](#).

Is the inspection result normal?

YES >> Replace ABS actuator and electric unit (control unit).

NO >> Repair or replace damaged parts.

Component Inspection

INFOID:000000003247148

1.CHECK DATA MONITOR

On "DATA MONITOR", select "FR LH SENSOR", "FR RH SENSOR", "RR LH SENSOR", and "RR RH SENSOR", and check the vehicle speed.

Wheel sensor	Condition	Vehicle speed (DATA MONITOR)
FR LH SENSOR	Vehicle stopped	0 [km/h (MPH)]
	Vehicle running (Note)	Nearly matches the speedometer display ($\pm 10\%$ or less)
FR RH SENSOR	Vehicle stopped	0 [km/h (MPH)]
	Vehicle running (Note)	Nearly matches the speedometer display ($\pm 10\%$ or less)
RR LH SENSOR	Vehicle stopped	0 [km/h (MPH)]
	Vehicle running (Note)	Nearly matches the speedometer display ($\pm 10\%$ or less)
RR RH SENSOR	Vehicle stopped	0 [km/h (MPH)]
	Vehicle running (Note)	Nearly matches the speedometer display ($\pm 10\%$ or less)

NOTE:

Confirm tire pressure is normal.

Is the inspection result normal?

YES >> INSPECTION END

NO >> Proceed to diagnosis procedure. Refer to [BRC-34. "Diagnosis Procedure"](#).

Special Repair Requirement

INFOID:000000003251911

1.AJUSTMENT OF STEERING ANGLE SENSOR NEUTRAL POSITION, CALIBRATION OF YAW RATE/SIDE/DECEL G SENSOR AND CALIBRATION OF PRESSURE SENSOR

After removing/replacing an ABS actuator and electric unit (control unit), be sure to perform the following procedure.

C1101, C1102, C1103, C1104 WHEEL SENSOR

< COMPONENT DIAGNOSIS >

[VDC/TCS/ABS]

- Adjustment of steering angle sensor neutral position: Refer to [BRC-9, "ADJUSTMENT OF STEERING ANGLE SENSOR NEUTRAL POSITION : Description"](#).
- Calibration of yaw rate/side/decel G sensor: Refer to [BRC-10, "CALIBRATION OF YAW RATE/SIDE/DECEL G SENSOR : Description"](#).
- Calibration of pressure sensor: Refer to [BRC-11, "CALIBRATION OF PRESSURE SENSOR : Description"](#).

>> END

A

B

C

D

E

BRC

G

H

I

J

K

L

M

N

O

P

C1105, C1106, C1107, C1108 WHEEL SENSOR

< COMPONENT DIAGNOSIS >

[VDC/TCS/ABS]

C1105, C1106, C1107, C1108 WHEEL SENSOR

Description

INFOID:000000003390264

When the sensor rotor rotates, the magnetic field changes. It converts the magnetic field changes to current signals (rectangular wave) and transmits them to the ABS actuator and electric unit (control unit).

DTC Logic

INFOID:000000003247150

DTC DETECTION LOGIC

DTC	Display item	Malfunction detected condition	Possible cause
C1105	RR RH SENSOR-2	Signal from rear RH wheel sensor does not match other 3 wheel speed signal.	<ul style="list-style-type: none">• Harness or connector• Wheel sensor• Sensor rotor• ABS actuator and electric unit (control unit)
C1106	RR LH SENSOR-2	Signal from rear LH wheel sensor does not match other 3 wheel speed signal.	
C1107	FR RH SENSOR-2	Signal from front RH wheel sensor does not match other 3 wheel speed signal.	
C1108	FR LH SENSOR-2	Signal from front LH wheel sensor does not match other 3 wheel speed signal.	

DTC CONFIRMATION PROCEDURE

1. DTC REPRODUCTION PROCEDURE

1. Start the engine and drive the vehicle at 30 km/h (19 MPH) or more for approximately 1 minute.
2. Perform ABS actuator and electric unit (control unit) self-diagnosis.

Is DTC "C1105", "C1106", "C1107" or "C1108" detected?

- YES >> Proceed to diagnosis procedure. Refer to [BRC-38, "Diagnosis Procedure"](#).
NO >> INSPECTION END

Diagnosis Procedure

INFOID:000000003390265

CAUTION:

- Do not measure the resistance value and also voltage between sensor terminals with tester etc., because the sensors are active sensors.
- Do not expand terminal of connector with a tester terminal stick, when it does the inspection with the tester.

1. CHECK TIRE

Check air pressure, wear, and size. Refer to [WT-111, "Tire Air Pressure"](#).

Is the inspection result normal?

- YES >> GO TO 2.
NO >> Repair or replace damaged parts.

2. CHECK SENSOR AND SENSOR ROTOR

- Check that there is no damage or adherence of foreign matter on the sensor rotor surface.
- Check sensor rotor for damage.
- Check wheel sensor for damage, disconnection or looseness.
- Check that there is no deformation on the wheel sensor mounting surface.

Is the inspection result normal?

- YES >> GO TO 3.
NO >> Repair wheel sensor mount or replace sensor rotor. Then perform the self-diagnosis.

3. CHECK CONNECTOR

1. Turn the ignition switch OFF.
2. Disconnect ABS actuator and electric unit (control unit) connector.
3. Disconnect malfunctioning wheel sensor connector.
4. Check terminal to see if it is deformed, disconnected, loose, etc.

Is the inspection result normal?

C1105, C1106, C1107, C1108 WHEEL SENSOR

< COMPONENT DIAGNOSIS >

[VDC/TCS/ABS]

- YES >> GO TO 4.
 NO >> Repair or replace damaged parts.

4. CHECK WHEEL SENSOR HARNESS

1. Check the continuity between ABS actuator and electric unit (control unit) harness connector and wheel sensor harness connector. (Also check continuity when steering wheel is turned right and left and when sensor harness inside the wheel house is moved.)

Measurement terminal for signal circuit

ABS actuator and electric unit (control unit)		Wheel sensor			Continuity
Connector	Terminal	Connector		Terminal	
E36	6	E39 (Front RH)		4	Existed
	8	E22 (Front LH)		2	
	12	C4 (2WD models) C6 (AWD models)	(Rear RH)	8	
	2	C3 (2WD models) C5 (AWD models)	(Rear LH)	6	

Measurement terminal for power supply circuit

ABS actuator and electric unit (control unit)		Wheel sensor			Continuity
Connector	Terminal	Connector		Terminal	
E36	5	E39 (Front RH)		3	Existed
	9	E22 (Front LH)		1	
	11	C4 (2WD models) C6 (AWD models)	(Rear RH)	7	
	3	C3 (2WD models) C5 (AWD models)	(Rear LH)	5	

2. Check the continuity between ABS actuator and electric unit (control unit) harness connector.

ABS actuator and electric unit (control unit)				Continuity
Connector	Terminal	Connector	Terminal	
E36	6, 5	E36	13, 26	Not existed
	8, 9			
	12, 11			
	2, 3			

Is the inspection result normal?

- YES >> GO TO 5.
 NO >> Repair or replace damaged parts.

5. CHECK WHEEL SENSOR POWER SUPPLY CIRCUIT

1. Connect ABS actuator and electric unit (control unit) connector.
2. Turn the ignition switch ON.
CAUTION:
Never start the engine.
3. Check the voltage between wheel sensor harness connector and ground.

Wheel sensor			—	Voltage
Connector	Terminal			
E39 (Front RH)	3		Ground	Approx. 8 V or more
E22 (Front LH)	1			
C4 (2WD models) C6 (AWD models)	(Rear RH)	7		
C3 (2WD models) C5 (AWD models)	(Rear LH)	5		

C1105, C1106, C1107, C1108 WHEEL SENSOR

[VDC/TCS/ABS]

< COMPONENT DIAGNOSIS >

Is the inspection result normal?

- YES >> GO TO 6.
- NO >> Repair or replace damaged parts.

6.CHECK DATA MONITOR

1. Turn the ignition switch OFF.
2. Connect each wheel sensor connector.
3. Check wheel sensor signal. Refer to [BRC-40, "Component Inspection"](#).

Is the inspection result normal?

- YES >> Replace ABS actuator and electric unit (control unit).
- NO >> Repair or replace damaged parts.

Component Inspection

INFOID:000000003390266

1.CHECK DATA MONITOR

On "DATA MONITOR", select "FR LH SENSOR", "FR RH SENSOR", "RR LH SENSOR", and "RR RH SENSOR", and check the vehicle speed.

Wheel sensor	Condition	Vehicle speed (DATA MONITOR)
FR LH SENSOR	Vehicle stopped	0 [km/h (MPH)]
	Vehicle running (Note)	Nearly matches the speedometer display ($\pm 10\%$ or less)
FR RH SENSOR	Vehicle stopped	0 [km/h (MPH)]
	Vehicle running (Note)	Nearly matches the speedometer display ($\pm 10\%$ or less)
RR LH SENSOR	Vehicle stopped	0 [km/h (MPH)]
	Vehicle running (Note)	Nearly matches the speedometer display ($\pm 10\%$ or less)
RR RH SENSOR	Vehicle stopped	0 [km/h (MPH)]
	Vehicle running (Note)	Nearly matches the speedometer display ($\pm 10\%$ or less)

NOTE:

Confirm tire pressure is normal.

Is the inspection result normal?

- YES >> INSPECTION END
- NO >> Proceed to diagnosis procedure. Refer to [BRC-38, "Diagnosis Procedure"](#).

Special Repair Requirement

INFOID:000000003390263

1.AJUSTMENT OF STEERING ANGLE SENSOR NEUTRAL POSITION, CALIBRATION OF YAW RATE/SIDE/DECEL G SENSOR AND CALIBRATION OF PRESSURE SENSOR

After removing/replacing an ABS actuator and electric unit (control unit), be sure to perform the following procedure.

- Adjustment of steering angle sensor neutral position: Refer to [BRC-9, "ADJUSTMENT OF STEERING ANGLE SENSOR NEUTRAL POSITION : Description"](#).
- Calibration of yaw rate/side/decel G sensor: Refer to [BRC-10, "CALIBRATION OF YAW RATE/SIDE/DECEL G SENSOR : Description"](#).
- Calibration of pressure sensor: Refer to [BRC-11, "CALIBRATION OF PRESSURE SENSOR : Description"](#).

>> END

C1109 POWER AND GROUND SYSTEM

< COMPONENT DIAGNOSIS >

[VDC/TCS/ABS]

C1109 POWER AND GROUND SYSTEM

Description

INFOID:000000003247153

Supplies electric power to the ABS actuator and electric unit (control unit).

DTC Logic

INFOID:000000003247154

DTC DETECTION LOGIC

DTC	Display item	Malfunction detected condition	Possible cause
C1109	BATTERY VOLTAGE [ABNORMAL]	When the ABS actuator and electric unit (control unit) power supply is lower than normal. Power supply is greater than normal limits.	<ul style="list-style-type: none"> • Harness or connector • ABS actuator and electric unit (control unit) • Fuse • Vehicle electrical power system

DTC CONFIRMATION PROCEDURE

1. DTC REPRODUCTION PROCEDURE

1. Turn the ignition switch OFF to ON.
2. Perform ABS actuator and electric unit (control unit) self-diagnosis.

Is DTC "C1109" detected?

- YES >> Proceed to diagnosis procedure. Refer to [BRC-41, "Diagnosis Procedure"](#).
 NO >> INSPECTION END

Diagnosis Procedure

INFOID:000000003247155

1. CHECK CONNECTOR

1. Turn the ignition switch OFF.
2. Disconnect ABS actuator and electric unit (control unit) connector.
3. Check terminal for deformation, disconnection, looseness, etc.

Is the inspection result normal?

- YES >> GO TO 2.
 NO >> Repair or replace damaged parts.

2. CHECK ABS ACTUATOR AND ELECTRIC UNIT (CONTROL UNIT) POWER SUPPLY CIRCUIT AND GROUND CIRCUIT

1. Turn ignition switch ON or OFF and check voltage between ABS actuator and electric unit (control unit) harness connector terminal and ground.

ABS actuator and electric unit (control unit)		—	Condition	Voltage
Connector	Terminal			
E36	20	Ground	Ignition switch: ON	Battery voltage
			Ignition switch: OFF	Approx. 0 V

2. Check 10A fusible link (45).
3. Check continuity between ABS actuator and electric unit (control unit) harness connector terminals and IPDM E/R.

ABS actuator and electric unit (control unit)		IPDM E/R		Continuity
Connector	Terminal	Connector	Terminal	
E36	20	E10	25	Existed

Is the inspection result normal?

- YES >> GO TO 3.
 NO >> Repair or replace malfunctioning components.

C1109 POWER AND GROUND SYSTEM

< COMPONENT DIAGNOSIS >

[VDC/TCS/ABS]

3. CHECK ABS ACTUATOR AND ELECTRIC UNIT (CONTROL UNIT) GROUND CIRCUIT

Check the continuity between ABS actuator and electric unit (control unit) harness connector and ground.

ABS actuator and electric unit (control unit)		—	Continuity
Connector	Terminal		
E36	13	Ground	Existed
	26		

Is the inspection result normal?

YES >> Check battery for terminal looseness, low voltage, etc. if any malfunction is found, repair damaged parts.

NO >> Repair or replace damaged parts. (Check ABS earth bolt for tightness and corrosion.)

Special Repair Requirement

INFOID:000000003390267

1. ADJUSTMENT OF STEERING ANGLE SENSOR NEUTRAL POSITION, CALIBRATION OF YAW RATE/SIDE/DECEL G SENSOR AND CALIBRATION OF PRESSURE SENSOR

After removing/replacing an ABS actuator and electric unit (control unit), be sure to perform the following procedure.

- Adjustment of steering angle sensor neutral position: Refer to [BRC-9, "ADJUSTMENT OF STEERING ANGLE SENSOR NEUTRAL POSITION : Description"](#).
- Calibration of yaw rate/side/decel G sensor: Refer to [BRC-10, "CALIBRATION OF YAW RATE/SIDE/DECEL G SENSOR : Description"](#).
- Calibration of pressure sensor: Refer to [BRC-11, "CALIBRATION OF PRESSURE SENSOR : Description"](#).

>> END

C1110, C1170 ABS ACTUATOR AND ELECTRIC UNIT (CONTROL UNIT)

< COMPONENT DIAGNOSIS >

[VDC/TCS/ABS]

C1110, C1170 ABS ACTUATOR AND ELECTRIC UNIT (CONTROL UNIT)

Description

INFOID:000000003247156

ABS actuator and electric unit (control unit) is continuously monitoring ECU hardware and software for correct operation.

DTC Logic

INFOID:000000003247157

DTC DETECTION LOGIC

DTC	Display item	Malfunction detected condition	Possible cause
C1110	CONTROLLER FAILURE	Possible internal failure of control unit components.	Internal failure of control unit components. ABS solenoid valve or motor power supply / ground abnormal.
C1170	VARIANT CODING	V coding is not functioning.	ABS actuator and electric unit (control unit)

DTC CONFIRMATION PROCEDURE

1. DTC REPRODUCTION PROCEDURE

1. Turn the ignition switch ON.
2. Perform ABS actuator and electric unit (control unit) self-diagnosis.

Is DTC "C1110" or "C1170" detected?

- YES >> Proceed to diagnosis procedure. Refer to [BRC-43, "Diagnosis Procedure"](#).
NO >> INSPECTION END

Diagnosis Procedure

INFOID:000000003247158

1. REPLACE ABS ACTUATOR AND ELECTRIC UNIT (CONTROL UNIT)

CAUTION:

Replace ABS actuator and electric unit (control unit) when self-diagnostic result shows items other than those applicable.

>> Replace ABS actuator and electric unit (control unit).

Special Repair Requirement

INFOID:000000003390268

1. ADJUSTMENT OF STEERING ANGLE SENSOR NEUTRAL POSITION, CALIBRATION OF YAW RATE/SIDE/DECEL G SENSOR AND CALIBRATION OF PRESSURE SENSOR

After removing/replacing an ABS actuator and electric unit (control unit), be sure to perform the following procedure.

- Adjustment of steering angle sensor neutral position: Refer to [BRC-9, "ADJUSTMENT OF STEERING ANGLE SENSOR NEUTRAL POSITION : Description"](#).
- Calibration of yaw rate/side/decel G sensor: Refer to [BRC-10, "CALIBRATION OF YAW RATE/SIDE/DECEL G SENSOR : Description"](#).
- Calibration of pressure sensor: Refer to [BRC-11, "CALIBRATION OF PRESSURE SENSOR : Description"](#).

>> END

C1111 ABS MOTOR, MOTOR RELAY SYSTEM

< COMPONENT DIAGNOSIS >

[VDC/TCS/ABS]

C1111 ABS MOTOR, MOTOR RELAY SYSTEM

Description

INFOID:000000003247159

PUMP

The pump returns the brake fluid stored in the reservoir to the master cylinder by reducing the pressure.

MOTOR

The motor drives the pump according to the signals transmitted by the ABS actuator and electric unit (control unit).

MOTOR RELAY

Activates or deactivates motor according to the signals transmitted by the ABS actuator and electric unit (control unit).

DTC Logic

INFOID:000000003247160

DTC DETECTION LOGIC

DTC	Display item	Malfunction detected condition	Possible cause
C1111	PUMP MOTOR	During the actuator motor operating with ON, when the actuator motor turns OFF, or when the control line for actuator motor relay is open.	<ul style="list-style-type: none">• Harness or connector• ABS actuator and electric unit (control unit)
		During the actuator motor operating with OFF, when the actuator motor turns ON, or when the control line for relay is shorted to ground.	

DTC CONFIRMATION PROCEDURE

1. DTC REPRODUCTION PROCEDURE

1. Turn the ignition switch ON.
2. Perform ABS actuator and electric unit (control unit) self-diagnosis.

Is DTC "C1111" detected?

- YES >> Proceed to diagnosis procedure. Refer to [BRC-44, "Diagnosis Procedure"](#).
NO >> INSPECTION END

Diagnosis Procedure

INFOID:000000003247161

1. CHECK CONNECTOR

1. Turn the ignition switch OFF.
2. Disconnect ABS actuator and electric unit (control unit) connector.
3. Check terminal for deformation, disconnect, looseness, etc.

Is the inspection result normal?

- YES >> GO TO 2.
NO >> Replace or repair damaged parts.

2. CHECK ABS MOTOR AND MOTOR RELAY POWER SUPPLY CIRCUIT

Check the voltage between ABS actuator and electric unit (control unit) harness connector and ground.

ABS actuator and electric unit (control unit)		—	Voltage
Connector	Terminal		
E36	14	Ground	Battery voltage

Is the inspection result normal?

- YES >> GO TO 3.
NO >> Repair or replace damaged parts.

3. CHECK ABS ACTUATOR AND ELECTRIC UNIT (CONTROL UNIT) GROUND CIRCUIT

Check the continuity between ABS actuator and electric unit (control unit) harness connector and ground.

C1111 ABS MOTOR, MOTOR RELAY SYSTEM

< COMPONENT DIAGNOSIS >

[VDC/TCS/ABS]

ABS actuator and electric unit (control unit)		—	Continuity
Connector	Terminal		
E36	13	Ground	Existed
	26		

Is the inspection result normal?

YES >> Replace ABS actuator and electric unit (control unit).

NO >> Repair or replace damaged parts. (Check ABS earth bolt for tightness and corrosion.)

Component Inspection

INFOID:000000003247162

1. CHECK ACTIVE TEST

1. On "ACTIVE TEST", select "ABS MOTOR".
2. Touch "On" and "Off" on screen. Make sure motor relay and actuator relay operates as shown in table below.

Test item	Display item	Display	
		On	Off
ABS MOTOR	MOTOR RELAY	On	Off
	ACTUATOR RLY	On	On

Is the inspection result normal?

YES >> INSPECTION END

NO >> Proceed to diagnosis procedure. Refer to [BRC-44, "Diagnosis Procedure"](#).

Special Repair Requirement

INFOID:000000003390269

1. ADJUSTMENT OF STEERING ANGLE SENSOR NEUTRAL POSITION, CALIBRATION OF YAW RATE/SIDE/DECEL G SENSOR AND CALIBRATION OF PRESSURE SENSOR

After removing/replacing an ABS actuator and electric unit (control unit), be sure to perform the following procedure.

- Adjustment of steering angle sensor neutral position: Refer to [BRC-9, "ADJUSTMENT OF STEERING ANGLE SENSOR NEUTRAL POSITION : Description"](#).
- Calibration of yaw rate/side/decel G sensor: Refer to [BRC-10, "CALIBRATION OF YAW RATE/SIDE/DECEL G SENSOR : Description"](#).
- Calibration of pressure sensor: Refer to [BRC-11, "CALIBRATION OF PRESSURE SENSOR : Description"](#).

>> END

C1113, C1145, C1146 YAW RATE/SIDE/DECEL G SENSOR

< COMPONENT DIAGNOSIS >

[VDC/TCS/ABS]

C1113, C1145, C1146 YAW RATE/SIDE/DECEL G SENSOR

Description

INFOID:000000003247163

Yaw rate/side/decel G sensor detects yaw rate/side/decel G affecting the vehicle, and transmits the data to the ABS actuator and electric unit (control unit) as an analog voltage signal.

DTC Logic

INFOID:000000003247164

DTC DETECTION LOGIC

DTC	Display item	Malfunction detected condition	Possible cause
C1113	G SENSOR	Yaw rate/side/decel G sensor is malfunctioning, or signal line of yaw rate/side/decel G sensor is open or shorted.	<ul style="list-style-type: none">• Harness or connector• ABS actuator and electric unit (control unit)• Yaw rate/side/decel G sensor• Electrical interference• Vehicle driven on AWD rolling road
C1145	YAW RATE SENSOR		
C1146	SIDE G-SEN CIRCUIT		

DTC CONFIRMATION PROCEDURE

1. DTC REPRODUCTION PROCEDURE

1. Turn the ignition switch ON.
2. Perform ABS actuator and electric unit (control unit) self-diagnosis.

Is DTC "C1113", "C1145" or "C1146" detected?

- YES >> Proceed to diagnosis procedure. Refer to [BRC-46, "Diagnosis Procedure"](#).
NO >> INSPECTION END

Diagnosis Procedure

INFOID:000000003247165

CAUTION:

- Sudden turns (such as spin turns, acceleration turns), drifting, etc. may cause yaw rate/side/decel G sensor circuit indicate a malfunction. However this is not a malfunction if normal operation can be resumed after restarting engine.
- When on a turntable, such as at a parking structure entrance, or when on a moving object with engine running, the VDC OFF indicator lamp might turn on and self-diagnosis using the CONSULT-III yaw rate sensor system malfunction might be displayed, but in this case there is no malfunction with yaw rate/side/decel G sensor circuit. As soon as the vehicle leaves the turntable or moving object, restart the engine to return the system to normal.

1. CHECK CONNECTOR

1. Turn the ignition switch OFF.
2. Disconnect ABS actuator and electric unit (control unit) connector.
3. Disconnect yaw rate/side/decel G sensor connector.
4. Check terminal for deformation, disconnection, looseness, etc.

Is the inspection result normal?

- YES >> GO TO 2.
NO >> Replace or repair damaged parts.

2. CHECK YAW RATE/SIDE/DECEL G SENSOR POWER SUPPLY CIRCUIT

1. Turn the ignition switch ON.
CAUTION:
Never start the engine.
2. Check the voltage between yaw rate/side/decel G sensor harness connector and ground.

Yaw rate/side/decel G sensor		—	Voltage
Connector	Terminal		
M52	3	Ground	Battery voltage

C1113, C1145, C1146 YAW RATE/SIDE/DECCEL G SENSOR

< COMPONENT DIAGNOSIS >

[VDC/TCS/ABS]

3. Turn the ignition switch OFF.
4. Check the voltage between yaw rate/side/deccl G sensor harness connector and ground.

Yaw rate/side/deccl G sensor		—	Voltage
Connector	Terminal		
M52	3	Ground	Approx. 0 V

Is the inspection result normal?

- YES >> GO TO 3.
 NO >> Repair or replace damaged parts.

3.CHECK YAW RATE/SIDE/DECCEL G SENSOR GROUND CIRCUIT

Check the continuity between yaw rate/side/deccl G sensor harness connector and ground.

Yaw rate/side/deccl G sensor		—	Continuity
Connector	Terminal		
M52	5	Ground	Existed

Is the inspection result normal?

- YES >> GO TO 4.
 NO >> Repair or replace damaged parts.

4.CHECK YAW RATE/SIDE/DECCEL G SENSOR HARNESS

Check the continuity between yaw rate/side/deccl G sensor harness connector and ABS actuator and electric unit (control unit) harness connector.

ABS actuator and electric unit (control unit)		Yaw rate/side/deccl G sensor		Continuity
Connector	Terminal	Connector	Terminal	
E36	25	M52	1	Existed
	19		2	
	4		3	
	10		5	

Is the inspection result normal?

- YES >> GO TO 5.
 NO >> Repair or replace damaged parts.

5.CHECK YAW RATE/SIDE/DECCEL G SENSOR

Check yaw rate/side/deccl G sensor signal. Refer to [BRC-47, "Component Inspection"](#).

Is the inspection result normal?

- YES >> Replace ABS actuator and electric unit (control unit).
 NO >> Replace yaw rate/side/deccl G sensor.

Component Inspection

INFOID:000000003247166

1.CHECK DATA MONITOR

Select "YAW RATE SEN", "SIDE G-SENSOR" and "DECCEL G-SEN", in "DATA MONITOR" and check yaw rate/side/deccl G sensor signal.

YAW RATE SENSOR

Vehicle condition	DATA MONITOR
Vehicle stopped	Approx. 0 d/s
Vehicle running	-100 to 100 d/s

C1113, C1145, C1146 YAW RATE/SIDE/DECEL G SENSOR

< COMPONENT DIAGNOSIS >

[VDC/TCS/ABS]

SIDE G SENSOR

Vehicle condition	DATA MONITOR
Vehicle stopped	Approx. 0 m/s ²
Vehicle running	-16.7 – 16.7 m/s ²

DECEL G SENSOR

Vehicle condition	DATA MONITOR
Vehicle stopped	Approx. 0 G
Vehicle running	-1.7 – +1.7 G

Is the inspection result normal?

YES >> INSPECTION END

NO >> Proceed to diagnosis procedure. Refer to [BRC-46, "Diagnosis Procedure"](#).

Special Repair Requirement

INFOID:000000003258595

1. ADJUSTMENT OF STEERING ANGLE SENSOR NEUTRAL POSITION, CALIBRATION OF YAW RATE/SIDE/DECEL G SENSOR AND CALIBRATION OF PRESSURE SENSOR

- After removing/replacing a yaw rate/side/decel G sensor, be sure to perform the following procedure.
 - Calibration of yaw rate/side/decel G sensor: Refer to [BRC-10, "CALIBRATION OF YAW RATE/SIDE/DECEL G SENSOR : Description"](#).
- After removing/replacing an ABS actuator and electric unit (control unit), be sure to perform the following procedure.
 - Adjustment of steering angle sensor neutral position: Refer to [BRC-9, "ADJUSTMENT OF STEERING ANGLE SENSOR NEUTRAL POSITION : Description"](#).
 - Calibration of yaw rate/side/decel G sensor: Refer to [BRC-10, "CALIBRATION OF YAW RATE/SIDE/DECEL G SENSOR : Description"](#).
 - Calibration of pressure sensor: Refer to [BRC-11, "CALIBRATION OF PRESSURE SENSOR : Description"](#).

>> END

C1115 WHEEL SENSOR

< COMPONENT DIAGNOSIS >

[VDC/TCS/ABS]

C1115 WHEEL SENSOR

Description

INFOID:000000003390271

When the sensor rotor rotates, the magnetic field changes. It converts the magnetic field changes to current signals (rectangular wave) and transmits them to the ABS actuator and electric unit (control unit).

DTC Logic

INFOID:000000003247168

DTC DETECTION LOGIC

DTC	Display item	Malfunction detected condition	Possible cause
C1115	ABS SENSOR [ABNORMAL SIGNAL]	Miss-match between the 4 wheel speed sensor signals.	Harness or connector not a possible cause. Other possible causes tire radius (due to wrong size or pressure) interference.

DTC CONFIRMATION PROCEDURE

1. DTC REPRODUCTION PROCEDURE

1. Start the engine and drive the vehicle at 30 km/h (19 MPH) or more for approximately 1 minute.
2. Perform ABS actuator and electric unit (control unit) self-diagnosis.

Is DTC "C1115" detected?

- YES >> Proceed to diagnosis procedure. Refer to [BRC-49. "Diagnosis Procedure"](#).
NO >> INSPECTION END

Diagnosis Procedure

INFOID:000000003390272

CAUTION:

- Do not measure the resistance value and also voltage between sensor terminals with tester etc., because the sensors are active sensors.
- Do not expand terminal of connector with a tester terminal stick, when it does the inspection with the tester.

1. CHECK TIRE

Check air pressure, wear, and size. Refer to [WT-111. "Tire Air Pressure"](#).

Is the inspection result normal?

- YES >> GO TO 2.
NO >> Repair or replace damaged parts.

2. CHECK SENSOR AND SENSOR ROTOR

- Check that there is no damage or adherence of foreign matter on the sensor rotor surface.
- Check sensor rotor for damage.
- Check wheel sensor for damage, disconnection or looseness.
- Check that there is no deformation on the wheel sensor mounting surface.

Is the inspection result normal?

- YES >> GO TO 3.
NO >> Repair wheel sensor mount or replace sensor rotor. Then perform the self-diagnosis.

3. CHECK CONNECTOR

1. Turn the ignition switch OFF.
2. Disconnect ABS actuator and electric unit (control unit) connector.
3. Disconnect wheel sensor connector.
4. Check terminal to see if it is deformed, disconnected, loose, etc.

Is the inspection result normal?

- YES >> GO TO 4.
NO >> Repair or replace damaged parts.

4. CHECK WHEEL SENSOR HARNESS

C1115 WHEEL SENSOR

[VDC/TCS/ABS]

< COMPONENT DIAGNOSIS >

1. Check the continuity between ABS actuator and electric unit (control unit) harness connector and wheel sensor harness connector. (Also check continuity when steering wheel is turned right and left and when sensor harness inside the wheel house is moved.)

Measurement terminal for signal circuit

ABS actuator and electric unit (control unit)		Wheel sensor			Continuity
Connector	Terminal	Connector	Terminal		
E36	6	E39 (Front RH)		4	Existed
	8	E22 (Front LH)		2	
	12	C4 (2WD models) C6 (AWD models)	(Rear RH)	8	
	2	C3 (2WD models) C5 (AWD models)	(Rear LH)	6	

Measurement terminal for power supply circuit

ABS actuator and electric unit (control unit)		Wheel sensor			Continuity
Connector	Terminal	Connector	Terminal		
E36	5	E39 (Front RH)		3	Existed
	9	E22 (Front LH)		1	
	11	C4 (2WD models) C6 (AWD models)	(Rear RH)	7	
	3	C3 (2WD models) C5 (AWD models)	(Rear LH)	5	

2. Check the continuity between ABS actuator and electric unit (control unit) harness connector.

ABS actuator and electric unit (control unit)				Continuity
Connector	Terminal	Connector	Terminal	
E36	6, 5	E36	13, 26	Not existed
	8, 9			
	12, 11			
	2, 3			

Is the inspection result normal?

YES >> GO TO 5.

NO >> Repair or replace damaged parts.

5. CHECK WHEEL SENSOR POWER SUPPLY CIRCUIT

1. Connect ABS actuator and electric unit (control unit) connector.
2. Turn the ignition switch ON.
CAUTION:
Never start the engine.
3. Check the voltage between wheel sensor harness connector and ground.

Wheel sensor			—	Voltage
Connector	Terminal			
E39 (Front RH)	3		Ground	Approx. 8 V or more
E22 (Front LH)	1			
C4 (2WD models) C6 (AWD models)	(Rear RH)	7		
C3 (2WD models) C5 (AWD models)	(Rear LH)	5		

Is the inspection result normal?

YES >> GO TO 6.

NO >> Repair or replace damaged parts.

C1115 WHEEL SENSOR

< COMPONENT DIAGNOSIS >

[VDC/TCS/ABS]

6. CHECK DATA MONITOR

1. Turn the ignition switch OFF.
2. Connect each wheel sensor connector.
3. Check wheel sensor signal. Refer to [BRC-51, "Component Inspection"](#).

Is the inspection result normal?

- YES >> Replace ABS actuator and electric unit (control unit).
NO >> Repair or replace damaged parts.

Component Inspection

INFOID:000000003390273

1. CHECK DATA MONITOR

On "DATA MONITOR", select "FR LH SENSOR", "FR RH SENSOR", "RR LH SENSOR", and "RR RH SENSOR", and check the vehicle speed.

Wheel sensor	Condition	Vehicle speed (DATA MONITOR)
FR LH SENSOR	Vehicle stopped	0 [km/h (MPH)]
	Vehicle running (Note)	Nearly matches the speedometer display ($\pm 10\%$ or less)
FR RH SENSOR	Vehicle stopped	0 [km/h (MPH)]
	Vehicle running (Note)	Nearly matches the speedometer display ($\pm 10\%$ or less)
RR LH SENSOR	Vehicle stopped	0 [km/h (MPH)]
	Vehicle running (Note)	Nearly matches the speedometer display ($\pm 10\%$ or less)
RR RH SENSOR	Vehicle stopped	0 [km/h (MPH)]
	Vehicle running (Note)	Nearly matches the speedometer display ($\pm 10\%$ or less)

NOTE:

Confirm tire pressure is normal.

Is the inspection result normal?

- YES >> INSPECTION END
NO >> Proceed to diagnosis procedure. Refer to [BRC-49, "Diagnosis Procedure"](#).

Special Repair Requirement

INFOID:000000003390274

1. ADJUSTMENT OF STEERING ANGLE SENSOR NEUTRAL POSITION, CALIBRATION OF YAW RATE/SIDE/DECEL G SENSOR AND CALIBRATION OF PRESSURE SENSOR

After removing/replacing an ABS actuator and electric unit (control unit), be sure to perform the following procedure.

- Adjustment of steering angle sensor neutral position: Refer to [BRC-9, "ADJUSTMENT OF STEERING ANGLE SENSOR NEUTRAL POSITION : Description"](#).
- Calibration of yaw rate/side/decel G sensor: Refer to [BRC-10, "CALIBRATION OF YAW RATE/SIDE/DECEL G SENSOR : Description"](#).
- Calibration of pressure sensor: Refer to [BRC-11, "CALIBRATION OF PRESSURE SENSOR : Description"](#).

>> END

C1116 STOP LAMP SWITCH

< COMPONENT DIAGNOSIS >

[VDC/TCS/ABS]

C1116 STOP LAMP SWITCH

Description

INFOID:000000003247171

The stop lamp switch transmits the stop lamp switch signal (ON/OFF) to the ABS actuator and electric unit (control unit).

DTC Logic

INFOID:000000003247172

DTC DETECTION LOGIC

DTC	Display item	Malfunction detected condition	Possible cause
C1116	STOP LAMP SW	When stop lamp switch circuit is open.	<ul style="list-style-type: none">• Harness or connector• Stop lamp switch• ABS actuator and electric unit (control unit)

DTC CONFIRMATION PROCEDURE

1. DTC REPRODUCTION PROCEDURE

1. Turn the ignition switch ON.
2. Perform ABS actuator and electric unit (control unit) self-diagnosis.

Is DTC "C1116" detected?

- YES >> Proceed to diagnosis procedure. Refer to [BRC-52. "Diagnosis Procedure"](#).
NO >> INSPECTION END

Diagnosis Procedure

INFOID:000000003247173

1. CHECK CONNECTOR

1. Turn the ignition switch OFF.
2. Disconnect ABS actuator and electric unit (control unit) connector.
3. Disconnect stop lamp switch connector.
4. Check terminal for deformation, disconnection, looseness, etc.

Is the inspection result normal?

- YES >> GO TO 2.
NO >> Replace or repair damaged parts.

2. CHECK STOP LAMP SWITCH

Check stop lamp switch. Refer to [BRC-53. "Component Inspection"](#).

Is the inspection result normal?

- YES >> GO TO 3.
NO >> Repair or replace stop lamp switch.

3. CHECK STOP LAMP SWITCH CIRCUIT

1. Turn the ignition switch OFF.
2. Check the voltage between ABS actuator and electric unit (control unit) harness connector and ground.

ABS actuator and electric unit (control unit)		—	Condition	Voltage
Connector	Terminal			
E36	16	Ground	Brake pedal is depressed	Battery voltage
			Brake pedal is released	Approx. 0 V

Is the inspection result normal?

- YES >> INSPECTION END
NO >> Repair or replace damaged parts.

C1116 STOP LAMP SWITCH

< COMPONENT DIAGNOSIS >

[VDC/TCS/ABS]

Component Inspection

INFOID:000000003247174

1. CHECK STOP LAMP SWITCH

1. Turn the ignition switch OFF.
2. Disconnect stop lamp switch connector.
3. Check the continuity between stop lamp switch connector terminals.

Stop lamp switch	Condition	Continuity
Terminal		
3 – 4* ¹	Release stop lamp switch (When brake pedal is depressed.)	Existed
1 – 2* ²	Push stop lamp switch (When brake pedal is released.)	Not existed

- *1: Up to VIN: JN8AZ18U*9W100000, JN8AZ18W*9W200000 (Except for Mexico), JN8AZ18U*9W710000, JN8AZ18W*9W810000 (For Mexico)
- *2: From VIN: JN8AZ18U*9W100001, JN8AZ18W*9W200001 (Except for Mexico), JN8AZ18U*9W710001, JN8AZ18W*9W810001 (For Mexico)

Is the inspection result normal?

YES >> INSPECTION END

NO >> Replace stop lamp switch. Refer to [BR-20, "Exploded View"](#).

Special Repair Requirement

INFOID:000000003390275

1. ADJUSTMENT OF STEERING ANGLE SENSOR NEUTRAL POSITION, CALIBRATION OF YAW RATE/SIDE/DECEL G SENSOR AND CALIBRATION OF PRESSURE SENSOR

After removing/replacing an ABS actuator and electric unit (control unit), be sure to perform the following procedure.

- Adjustment of steering angle sensor neutral position: Refer to [BRC-9, "ADJUSTMENT OF STEERING ANGLE SENSOR NEUTRAL POSITION : Description"](#).
- Calibration of yaw rate/side/decel G sensor: Refer to [BRC-10, "CALIBRATION OF YAW RATE/SIDE/DECEL G SENSOR : Description"](#).
- Calibration of pressure sensor: Refer to [BRC-11, "CALIBRATION OF PRESSURE SENSOR : Description"](#).

>> END

C1120, C1122, C1124, C1126 IN ABS SOL

< COMPONENT DIAGNOSIS >

[VDC/TCS/ABS]

C1120, C1122, C1124, C1126 IN ABS SOL

Description

INFOID:000000003247178

The solenoid valve increases, holds or decreases the fluid pressure of each brake caliper according to the signals transmitted by the ABS actuator and electric unit (control unit).

DTC Logic

INFOID:000000003247179

DTC DETECTION LOGIC

DTC	Display item	Malfunction detected condition	Possible cause
C1120	FR LH IN ABS SOL	When the control unit detects a malfunction in the front LH inlet solenoid circuit.	ABS actuator and electric unit (control unit)
C1122	FR RH IN ABS SOL	When the control unit detects a malfunction in the front RH inlet solenoid circuit.	
C1124	RR LH IN ABS SOL	When the control unit detects a malfunction in the rear LH inlet solenoid circuit.	
C1126	RR RH IN ABS SOL	When the control unit detects a malfunction in the rear RH inlet solenoid circuit.	

DTC CONFIRMATION PROCEDURE

1. DTC REPRODUCTION PROCEDURE

1. Turn the ignition switch ON.
2. Perform ABS actuator and electric unit (control unit) self-diagnosis.

Is DTC "C1120", "C1122", "C1124" or "C1126" detected?

- YES >> Proceed to diagnosis procedure. Refer to [BRC-54, "Diagnosis Procedure"](#).
NO >> INSPECTION END

Diagnosis Procedure

INFOID:000000003247180

1. CHECK CONNECTOR

1. Turn the ignition switch OFF.
2. Disconnect ABS actuator and electric unit (control unit) connector.
3. Check terminal for deformation, disconnection, looseness, etc.

Is the inspection result normal?

- YES >> GO TO 2.
NO >> Replace or repair damaged parts.

2. CHECK SOLENOID, VDC SWITCH-OVER VALVE AND ACTUATOR RELAY POWER SUPPLY CIRCUIT

Check the voltage between ABS actuator and electric unit (control unit) harness connector and ground.

ABS actuator and electric unit (control unit)		—	Voltage
Connector	Terminal		
E36	1	Ground	Battery voltage

Is the inspection result normal?

- YES >> GO TO 3.
NO >> Repair or replace damaged parts.

3. CHECK SOLENOID, VDC SWITCH-OVER VALVE AND ACTUATOR RELAY GROUND CIRCUIT

Check the continuity between ABS actuator and electric unit (control unit) harness connector and ground.

C1120, C1122, C1124, C1126 IN ABS SOL

< COMPONENT DIAGNOSIS >

[VDC/TCS/ABS]

ABS actuator and electric unit (control unit)		—	Continuity
Connector	Terminal		
E36	13	Ground	Existed
	26		

Is the inspection result normal?

- YES >> Replace ABS actuator and electric unit (control unit).
 NO >> Repair or replace damaged parts.

Component Inspection

INFOID:000000003247181

1. CHECK ACTIVE TEST

1. Select each test menu item on "ACTIVE TEST."
2. On the display, touch "Up", "Keep", and "Down", and check that the system operates as shown in the table below.

Test item	Display item	Display		
		Up	Keep	Down
FR RH SOL	FR RH IN SOL	Off	On	On
	FR RH OUT SOL	Off	Off	On*
	CV1	Off	Off	Off
	SV1	Off	Off	Off
FR LH SOL	FR LH IN SOL	Off	On	On
	FR LH OUT SOL	Off	Off	On*
	CV2	Off	Off	Off
	SV2	Off	Off	Off
RR RH SOL	RR RH IN SOL	Off	On	On
	RR RH OUT SOL	Off	Off	On*
	CV2	Off	Off	Off
	SV2	Off	Off	Off
RR LH SOL	RR LH IN SOL	Off	On	On
	RR LH OUT SOL	Off	Off	On*
	CV1	Off	Off	Off
	SV1	Off	Off	Off

*: On for 1 to 2 seconds after the touch, and then Off.

Is the inspection result normal?

- YES >> INSPECTION END
 NO >> Proceed to diagnosis procedure. Refer to [BRC-54, "Diagnosis Procedure"](#).

Special Repair Requirement

INFOID:000000003390276

1. ADJUSTMENT OF STEERING ANGLE SENSOR NEUTRAL POSITION, CALIBRATION OF YAW RATE/SIDE/DECEL G SENSOR AND CALIBRATION OF PRESSURE SENSOR

After removing/replacing an ABS actuator and electric unit (control unit), be sure to perform the following procedure.

- Adjustment of steering angle sensor neutral position: Refer to [BRC-9, "ADJUSTMENT OF STEERING ANGLE SENSOR NEUTRAL POSITION : Description"](#).
- Calibration of yaw rate/side/decel G sensor: Refer to [BRC-10, "CALIBRATION OF YAW RATE/SIDE/DECEL G SENSOR : Description"](#).
- Calibration of pressure sensor: Refer to [BRC-11, "CALIBRATION OF PRESSURE SENSOR : Description"](#).

C1120, C1122, C1124, C1126 IN ABS SOL

< COMPONENT DIAGNOSIS >

[VDC/TCS/ABS]

>> END

C1121, C1123, C1125, C1127 OUT ABS SOL

< COMPONENT DIAGNOSIS >

[VDC/TCS/ABS]

C1121, C1123, C1125, C1127 OUT ABS SOL

Description

INFOID:000000003390278

The solenoid valve increases, holds or decreases the fluid pressure of each brake caliper according to the signals transmitted by the ABS actuator and electric unit (control unit).

DTC Logic

INFOID:000000003247183

DTC DETECTION LOGIC

DTC	Display item	Malfunction detected condition	Possible cause
C1121	FR LH OUT ABS SOL	When the control unit detects a malfunction in the front LH outlet solenoid circuit.	ABS actuator and electric unit (control unit)
C1123	FR RH OUT ABS SOL	When the control unit detects a malfunction in the front RH outlet solenoid circuit.	
C1125	RR LH OUT ABS SOL	When the control unit detects a malfunction in the rear LH outlet solenoid circuit.	
C1127	RR RH OUT ABS SOL	When the control unit detects a malfunction in the rear RH outlet solenoid circuit.	

DTC CONFIRMATION PROCEDURE

1. DTC REPRODUCTION PROCEDURE

1. Turn the ignition switch ON.
2. Perform ABS actuator and electric unit (control unit) self-diagnosis.

Is DTC "C1121", "C1123", "C1125" or "C1127" detected?

- YES >> Proceed to diagnosis procedure. Refer to [BRC-57, "Diagnosis Procedure"](#).
 NO >> INSPECTION END

Diagnosis Procedure

INFOID:000000003390279

1. CHECK CONNECTOR

1. Turn the ignition switch OFF.
2. Disconnect ABS actuator and electric unit (control unit) connector.
3. Check terminal for deformation, disconnection, looseness, etc.

Is the inspection result normal?

- YES >> GO TO 2.
 NO >> Replace or repair damaged parts.

2. CHECK SOLENOID, VDC SWITCH-OVER VALVE AND ACTUATOR RELAY POWER SUPPLY CIRCUIT

Check the voltage between ABS actuator and electric unit (control unit) harness connector and ground.

ABS actuator and electric unit (control unit)		—	Voltage
Connector	Terminal		
E36	1	Ground	Battery voltage

Is the inspection result normal?

- YES >> GO TO 3.
 NO >> Repair or replace damaged parts.

3. CHECK SOLENOID, VDC SWITCH-OVER VALVE AND ACTUATOR RELAY GROUND CIRCUIT

Check the continuity between ABS actuator and electric unit (control unit) harness connector and ground.

C1121, C1123, C1125, C1127 OUT ABS SOL

< COMPONENT DIAGNOSIS >

[VDC/TCS/ABS]

ABS actuator and electric unit (control unit)		—	Continuity
Connector	Terminal		
E36	13	Ground	Existed
	26		

Is the inspection result normal?

- YES >> Replace ABS actuator and electric unit (control unit).
 NO >> Repair or replace damaged parts.

Component Inspection

INFOID:000000003390280

1. CHECK ACTIVE TEST

- Select each test menu item on "ACTIVE TEST."
- On the display, touch "Up", "Keep", and "Down", and check that the system operates as shown in the table below.

Test item	Display item	Display		
		Up	Keep	Down
FR RH SOL	FR RH IN SOL	Off	On	On
	FR RH OUT SOL	Off	Off	On*
	CV1	Off	Off	Off
	SV1	Off	Off	Off
FR LH SOL	FR LH IN SOL	Off	On	On
	FR LH OUT SOL	Off	Off	On*
	CV2	Off	Off	Off
	SV2	Off	Off	Off
RR RH SOL	RR RH IN SOL	Off	On	On
	RR RH OUT SOL	Off	Off	On*
	CV2	Off	Off	Off
	SV2	Off	Off	Off
RR LH SOL	RR LH IN SOL	Off	On	On
	RR LH OUT SOL	Off	Off	On*
	CV1	Off	Off	Off
	SV1	Off	Off	Off

*: On for 1 to 2 seconds after the touch, and then Off.

Is the inspection result normal?

- YES >> INSPECTION END
 NO >> Proceed to diagnosis procedure. Refer to [BRC-57, "Diagnosis Procedure"](#).

Special Repair Requirement

INFOID:000000003390277

1. ADJUSTMENT OF STEERING ANGLE SENSOR NEUTRAL POSITION, CALIBRATION OF YAW RATE/SIDE/DECEL G SENSOR AND CALIBRATION OF PRESSURE SENSOR

After removing/replacing an ABS actuator and electric unit (control unit), be sure to perform the following procedure.

- Adjustment of steering angle sensor neutral position: Refer to [BRC-9, "ADJUSTMENT OF STEERING ANGLE SENSOR NEUTRAL POSITION : Description"](#).
- Calibration of yaw rate/side/decel G sensor: Refer to [BRC-10, "CALIBRATION OF YAW RATE/SIDE/DECEL G SENSOR : Description"](#).
- Calibration of pressure sensor: Refer to [BRC-11, "CALIBRATION OF PRESSURE SENSOR : Description"](#).

C1121, C1123, C1125, C1127 OUT ABS SOL

< COMPONENT DIAGNOSIS >

[VDC/TCS/ABS]

>> END

A

B

C

D

E

BRC

G

H

I

J

K

L

M

N

O

P

C1130 ENGINE SIGNAL

Description

INFOID:000000003247186

ABS actuator and electric unit (control unit) and ECM exchange the engine signal via CAN communication line.

DTC Logic

INFOID:000000003247187

DTC DETECTION LOGIC

DTC	Display item	Malfunction detected condition	Possible cause
C1130	ENGINE SIGNAL 1	ECM signals are invalid or ECM self diagnosis indicates a fault that prevents correct TCS operation.	<ul style="list-style-type: none"> • Harness or connector • ABS actuator and electric unit (control unit) • ECM • CAN communication line

DTC CONFIRMATION PROCEDURE

1. DTC REPRODUCTION PROCEDURE

1. Turn the ignition switch ON.
2. Perform ABS actuator and electric unit (control unit) self-diagnosis.

Is DTC "C1130" detected?

- YES >> Proceed to diagnosis procedure. Refer to [BRC-60, "Diagnosis Procedure"](#).
 NO >> INSPECTION END

Diagnosis Procedure

INFOID:000000003247188

1. ECM SELF-DIAGNOSIS

Perform ECM self-diagnosis.

Is any item indicated on the self-diagnosis display?

- YES >> Check the malfunctioning system.
 NO >> GO TO 2.

2. ABS ACTUATOR AND ELECTRIC UNIT (CONTROL UNIT) SELF-DIAGNOSIS

1. Erase ABS actuator and electric unit (control unit) self-diagnosis results.
2. Turn the ignition switch OFF.
3. Start the engine. Drive the vehicle for a while.
4. Make sure that malfunction indicator lamp (MIL) turns OFF.
5. Stop the vehicle. Perform ABS actuator and electric unit (control unit) self-diagnosis.

Is any item indicated on the self-diagnosis display?

- YES >> Replace ABS actuator and electric unit (control unit).
 NO >> Check ABS actuator and electric unit (control unit) pin terminals for damage or loose connection with harness connector. If any items are damaged, repair or replace damaged parts.

Special Repair Requirement

INFOID:000000003390281

1. ADJUSTMENT OF STEERING ANGLE SENSOR NEUTRAL POSITION, CALIBRATION OF YAW RATE/SIDE/DECEL G SENSOR AND CALIBRATION OF PRESSURE SENSOR

After removing/replacing an ABS actuator and electric unit (control unit), be sure to perform the following procedure.

- Adjustment of steering angle sensor neutral position: Refer to [BRC-9, "ADJUSTMENT OF STEERING ANGLE SENSOR NEUTRAL POSITION : Description"](#).
- Calibration of yaw rate/side/decel G sensor: Refer to [BRC-10, "CALIBRATION OF YAW RATE/SIDE/DECEL G SENSOR : Description"](#).
- Calibration of pressure sensor: Refer to [BRC-11, "CALIBRATION OF PRESSURE SENSOR : Description"](#).

C1130 ENGINE SIGNAL

< COMPONENT DIAGNOSIS >

[VDC/TCS/ABS]

>> END

A

B

C

D

E

BRC

G

H

I

J

K

L

M

N

O

P

C1140 ACTUATOR RELAY SYSTEM

< COMPONENT DIAGNOSIS >

[VDC/TCS/ABS]

C1140 ACTUATOR RELAY SYSTEM

Description

INFOID:000000003247189

Activates or deactivates each solenoid valve according to the signals transmitted by the ABS actuator and electric unit (control unit).

DTC Logic

INFOID:000000003247190

DTC DETECTION LOGIC

DTC	Display item	Malfunction detected condition	Possible cause
C1140	ACTUATOR RLY	During the actuator relay operating with OFF, when the actuator relay turns ON, or when the control line for the relay is shorted to the ground.	<ul style="list-style-type: none"> • Harness or connector • ABS actuator and electric unit (control unit)
		During the actuator relay operating with ON, when the actuator relay turns ON, or when the control line for the relay is open.	

DTC CONFIRMATION PROCEDURE

1. DTC REPRODUCTION PROCEDURE

1. Turn the ignition switch ON.
2. Perform ABS actuator and electric unit (control unit) self-diagnosis.

Is DTC "C1140" detected?

- YES >> Proceed to diagnosis procedure. Refer to [BRC-62, "Diagnosis Procedure"](#).
 NO >> INSPECTION END

Diagnosis Procedure

INFOID:000000003247191

1. CHECK CONNECTOR

1. Turn the ignition switch OFF.
2. Disconnect ABS actuator and electric unit (control unit) connector.
3. Check terminal for deformation, disconnection, looseness, etc.

Is the inspection result normal?

- YES >> GO TO 2.
 NO >> Replace or repair damaged parts.

2. CHECK SOLENOID, VDC SWITCH-OVER VALVE AND ACTUATOR RELAY POWER SUPPLY CIRCUIT

Check the voltage between ABS actuator and electric unit (control unit) harness connector and ground.

ABS actuator and electric unit (control unit)		—	Voltage
Connector	Terminal		
E36	1	Ground	Battery voltage

Is the inspection result normal?

- YES >> GO TO 3.
 NO >> Repair or replace damaged parts.

3. CHECK ABS ACTUATOR AND ELECTRIC UNIT (CONTROL UNIT) GROUND CIRCUIT

Check the continuity between ABS actuator and electric unit (control unit) harness connector and ground.

ABS actuator and electric unit (control unit)		—	Continuity
Connector	Terminal		
E36	13	Ground	Existed
	26		

C1140 ACTUATOR RELAY SYSTEM

< COMPONENT DIAGNOSIS >

[VDC/TCS/ABS]

Is the inspection result normal?

- YES >> Replace ABS actuator and electric unit (control unit).
NO >> Repair or replace damaged parts. (Check ABS each bolt for tightness and corrosion.)

Component Inspection

INFOID:000000003390270

1.CHECK ACTIVE TEST

1. On "ACTIVE TEST", select "ABS MOTOR".
2. Touch "On" and "Off" on screen. Make sure motor relay and actuator relay operates as shown in table below.

Test item	Display item	Display	
		On	Off
ABS MOTOR	MOTOR RELAY	On	Off
	ACTUATOR RLY	On	On

Is the inspection result normal?

- YES >> INSPECTION END
NO >> Proceed to diagnosis procedure. Refer to [BRC-62, "Diagnosis Procedure"](#).

Special Repair Requirement

INFOID:000000003390282

1.ADJUSTMENT OF STEERING ANGLE SENSOR NEUTRAL POSITION, CALIBRATION OF YAW RATE/SIDE/DECEL G SENSOR AND CALIBRATION OF PRESSURE SENSOR

After removing/replacing an ABS actuator and electric unit (control unit), be sure to perform the following procedure.

- Adjustment of steering angle sensor neutral position: Refer to [BRC-9, "ADJUSTMENT OF STEERING ANGLE SENSOR NEUTRAL POSITION : Description"](#).
- Calibration of yaw rate/side/decel G sensor: Refer to [BRC-10, "CALIBRATION OF YAW RATE/SIDE/DECEL G SENSOR : Description"](#).
- Calibration of pressure sensor: Refer to [BRC-11, "CALIBRATION OF PRESSURE SENSOR : Description"](#).

>> END

C1142 PRESS SENSOR

[VDC/TCS/ABS]

< COMPONENT DIAGNOSIS >

C1142 PRESS SENSOR

Description

INFOID:000000003247311

The pressure sensor converts the brake fluid pressure to an electric signal and transmits it to the ABS actuator and electric unit (control unit). [The pressure sensor is integrated in the ABS actuator and electric unit (control unit).]

DTC Logic

INFOID:000000003247312

DTC DETECTION LOGIC

DTC	Display item	Malfunction detected condition	Possible cause
C1142	PRESS SEN CIRCUIT	Pressure sensor signal line is open or shorted, or pressure sensor is malfunctioning.	<ul style="list-style-type: none">• Harness or connector• Stop lamp switch• ABS actuator and electric unit (control unit)

DTC CONFIRMATION PROCEDURE

1. DTC REPRODUCTION PROCEDURE

1. Turn the ignition switch ON.
2. Perform ABS actuator and electric unit (control unit) self-diagnosis.

Is DTC "C1142" detected?

- YES >> Proceed to diagnosis procedure. Refer to [BRC-64, "Diagnosis Procedure"](#).
NO >> INSPECTION END

Diagnosis Procedure

INFOID:000000003247313

1. CHECK STOP LAMP SWITCH

Check stop lamp switch. Refer to [BRC-52, "Diagnosis Procedure"](#).

Is the inspection result normal?

- YES >> GO TO 2.
NO >> Repair or replace damaged parts.

2. CHECK DATA MONITOR

Check pressure sensor signal. Refer to [BRC-64, "Component Inspection"](#).

Is the inspection result normal?

- YES >> GO TO 3.
NO >>
 - Check brake pedal, brake booster, and master cylinder for mount play, looseness, brake system fluid leakage, etc.
 - Brake pedal: Refer to [BR-9, "Inspection and Adjustment"](#).
 - Brake booster: Refer to [BR-15, "Inspection"](#).
 - Master cylinder: Refer to [BR-14, "Inspection"](#).

3. ABS ACTUATOR AND ELECTRIC UNIT (CONTROL UNIT) SELF-DIAGNOSIS

Perform ABS actuator and electric unit (control unit) self-diagnosis.

Is any item indicated on the self-diagnosis display?

- YES >> Replace ABS actuator and electric unit (control unit).
NO >> Check ABS actuator and electric unit (control unit) pin terminals for damage or loose connection with harness connector. If any items are damaged, repair or replace damaged parts.

Component Inspection

INFOID:000000003247314

1. CHECK DATA MONITOR

On "DATA MONITOR", select "PRESS SENSOR" and check the brake fluid pressure.

C1142 PRESS SENSOR

< COMPONENT DIAGNOSIS >

[VDC/TCS/ABS]

Condition	PRESS SENSOR (DATA MONITOR)
With ignition switch turned ON and brake pedal released.	Approx. 0 bar
With ignition switch turned ON and brake pedal depressed.	0 to 170 bar

Is the inspection result normal?

YES >> INSPECTION END

NO >> Proceed to diagnosis procedure. Refer to [BRC-64, "Diagnosis Procedure"](#).

Special Repair Requirement

INFOID:000000003398543

1. ADJUSTMENT OF STEERING ANGLE SENSOR NEUTRAL POSITION, CALIBRATION OF YAW RATE/SIDE/DECEL G SENSOR AND CALIBRATION OF PRESSURE SENSOR

After removing/replacing an ABS actuator and electric unit (control unit), be sure to perform the following procedure.

- Adjustment of steering angle sensor neutral position: Refer to [BRC-9, "ADJUSTMENT OF STEERING ANGLE SENSOR NEUTRAL POSITION : Description"](#).
- Calibration of yaw rate/side/decel G sensor: Refer to [BRC-10, "CALIBRATION OF YAW RATE/SIDE/DECEL G SENSOR : Description"](#).
- Calibration of pressure sensor: Refer to [BRC-11, "CALIBRATION OF PRESSURE SENSOR : Description"](#).

>> END

A
B
C
D
E
BRC
G
H
I
J
K
L
M
N
O
P

C1143 STEERING ANGLE SENSOR

< COMPONENT DIAGNOSIS >

[VDC/TCS/ABS]

C1143 STEERING ANGLE SENSOR

Description

INFOID:000000003247193

The steering angle sensor detects the rotation amount, angular velocity and direction of the steering wheel, and transmits the data to the ABS actuator and electric unit (control unit) via CAN communication.

DTC Logic

INFOID:000000003247194

DTC DETECTION LOGIC

DTC	Display item	Malfunction detected condition	Possible cause
C1143	ST ANG SEN CIRCUIT	Neutral position of steering angle sensor is dislocated, or the steering angle sensor is malfunctioning.	<ul style="list-style-type: none">• Harness or connector• Steering angle sensor• ABS actuator and electric unit (control unit)

DTC CONFIRMATION PROCEDURE

1. DTC REPRODUCTION PROCEDURE

1. Turn the ignition switch ON.
2. Perform ABS actuator and electric unit (control unit) self-diagnosis.

Is DTC "C1143" detected?

- YES >> Proceed to diagnosis procedure. Refer to [BRC-66. "Diagnosis Procedure"](#).
NO >> INSPECTION END

Diagnosis Procedure

INFOID:000000003247195

1. CHECK CONNECTOR

1. Turn the ignition switch OFF.
2. Disconnect ABS actuator and electric unit (control unit) connector.
3. Disconnect steering angle sensor connector.
4. Check terminal for deformation, disconnection, looseness, etc.

Is the inspection result normal?

- YES >> GO TO 2.
NO >> Replace or repair damaged parts.

2. CHECK STEERING ANGLE SENSOR HARNESS

1. Turn the ignition switch ON.
CAUTION:
Never start the engine.
2. Check the voltage between steering angle sensor harness connector and ground.

Steering angle sensor		—	Voltage
Connector	Terminal		
M30	4	Ground	Battery voltage

3. Turn ignition switch OFF.
4. Check the continuity between steering angle sensor harness connector and ground.

Steering angle sensor		—	Continuity
Connector	Terminal		
M30	1	Ground	Existed

Is the inspection result normal?

- YES >> GO TO 3.
NO >> Repair or replace damaged parts.

C1143 STEERING ANGLE SENSOR

[VDC/TCS/ABS]

< COMPONENT DIAGNOSIS >

3.CHECK STEERING WHEEL PLAY

Check steering wheel play. Refer to [ST-12. "Inspection"](#).

Is the inspection result normal?

YES >> GO TO 4.

NO >> Adjust steering wheel play.

4.CHECK DATA MONITOR

1. Connect the steering angle sensor connector and ABS actuator and electric unit (control unit) connector.

2. Check steering angle sensor signal. Refer to [BRC-67. "Component Inspection"](#).

Is the inspection result normal?

YES >> Replace ABS actuator and electric unit (control unit).

NO >> Adjust neutral position of steering angle sensor.

Component Inspection

INFOID:000000003247196

1.CHECK DATA MONITOR

Select "STR ANGLE SIG" in "DATA MONITOR" and check steering angle sensor signal.

Steering condition	STR ANGLE SIG (DATA MONITOR)
Driving straight	-3.5 – +3.5°
Turn 90 ° to right	Approx. -90 °
Turn 90 ° to left	Approx. +90 °

Is the inspection result normal?

YES >> INSPECTION END

NO >> Proceed to diagnosis procedure. Refer to [BRC-66. "Diagnosis Procedure"](#).

Special Repair Requirement

INFOID:000000003247197

1.AJUSTMENT OF STEERING ANGLE SENSOR NEUTRAL POSITION, CALIBRATION OF YAW RATE/SIDE/DECEL G SENSOR AND CALIBRATION OF PRESSURE SENSOR

- After removing/replacing a steering angle sensor, be sure to perform the following procedure.
 - Adjustment of steering angle sensor neutral position: Refer to [BRC-9. "ADJUSTMENT OF STEERING ANGLE SENSOR NEUTRAL POSITION : Description"](#).
- After removing/replacing an ABS actuator and electric unit (control unit), be sure to perform the following procedure.
 - Adjustment of steering angle sensor neutral position: Refer to [BRC-9. "ADJUSTMENT OF STEERING ANGLE SENSOR NEUTRAL POSITION : Description"](#).
 - Calibration of yaw rate/side/decel G sensor: Refer to [BRC-10. "CALIBRATION OF YAW RATE/SIDE/DECEL G SENSOR : Description"](#).
 - Calibration of pressure sensor: Refer to [BRC-11. "CALIBRATION OF PRESSURE SENSOR : Description"](#).

>> END

C1144 INCOMPLETE STEERING ANGLE SENSOR ADJUSTMENT

< COMPONENT DIAGNOSIS >

[VDC/TCS/ABS]

C1144 INCOMPLETE STEERING ANGLE SENSOR ADJUSTMENT

DTC Logic

INFOID:000000003251895

DTC DETECTION LOGIC

DTC	Display item	Malfunction detected condition	Possible cause
C1144	ST ANG SEN SIGNAL	Neutral position of steering angle sensor is not finished.	<ul style="list-style-type: none">• Harness or connector• Steering angle sensor• ABS actuator and electric unit (control unit)

DTC CONFIRMATION PROCEDURE

1. DTC REPRODUCTION PROCEDURE

1. Turn the ignition switch ON.
2. Select "ST ANGLE SENSOR ADJUSTMENT" in "WORK SUPPORT", and perform adjust the neutral position of steering angle sensor.
3. Perform ABS actuator and electric unit (control unit) self-diagnosis.

Is DTC "C1144" detected?

- YES >> Proceed to diagnosis procedure. Refer to [BRC-68. "Diagnosis Procedure"](#).
NO >> INSPECTION END

Diagnosis Procedure

INFOID:000000003251896

1. CHECK STEERING ANGLE SENSOR

Check steering angle sensor. Refer to [BRC-66. "Diagnosis Procedure"](#).

Is the inspection result normal?

- YES >> Replace ABS actuator and electric unit (control unit).
NO >> Repair or replace damaged parts.

Special Repair Requirement

INFOID:000000003398544

1. ADJUSTMENT OF STEERING ANGLE SENSOR NEUTRAL POSITION, CALIBRATION OF YAW RATE/SIDE/DECEL G SENSOR AND CALIBRATION OF PRESSURE SENSOR

- After removing/replacing a steering angle sensor, be sure to perform the following procedure.
- Adjustment of steering angle sensor neutral position: Refer to [BRC-9. "ADJUSTMENT OF STEERING ANGLE SENSOR NEUTRAL POSITION : Description"](#).
- After removing/replacing an ABS actuator and electric unit (control unit), be sure to perform the following procedure.
- Adjustment of steering angle sensor neutral position: Refer to [BRC-9. "ADJUSTMENT OF STEERING ANGLE SENSOR NEUTRAL POSITION : Description"](#).
- Calibration of yaw rate/side/decel G sensor: Refer to [BRC-10. "CALIBRATION OF YAW RATE/SIDE/DECEL G SENSOR : Description"](#).
- Calibration of pressure sensor: Refer to [BRC-11. "CALIBRATION OF PRESSURE SENSOR : Description"](#).

>> END

C1155 BRAKE FLUID LEVEL SWITCH

< COMPONENT DIAGNOSIS >

[VDC/TCS/ABS]

C1155 BRAKE FLUID LEVEL SWITCH

Description

INFOID:000000003247198

The brake fluid level switch converts the brake fluid level to an electric signal and transmits it to the ABS actuator and electric unit (control unit).

DTC Logic

INFOID:000000003247199

DTC DETECTION LOGIC

DTC	Display item	Malfunction detected condition	Possible cause
C1155	BR FLUID LEVEL LOW	Ignition switch ON and brake fluid signal low or not available for 10 seconds.	<ul style="list-style-type: none">• Brake fluid level low• Brake fluid level switch failure• Wiring to brake fluid level switch short circuit

DTC CONFIRMATION PROCEDURE

1. DTC REPRODUCTION PROCEDURE

1. Turn the ignition switch ON.
2. Perform ABS actuator and electric unit (control unit) self-diagnosis.

Is DTC "C1155" detected?

- YES >> Proceed to diagnosis procedure. Refer to [BRC-69. "Diagnosis Procedure"](#).
NO >> INSPECTION END

Diagnosis Procedure

INFOID:000000003247200

1. CHECK BRAKE FLUID LEVEL

Check the brake fluid level.

Is the inspection result normal?

- YES >> GO TO 2.
NO >> Investigate and fix.

2. CHECK BRAKE WARNING LAMP 1

Check that the brake warning lamp illuminates after the ignition switch is turned ON.

Is the inspection result normal?

- YES >> GO TO 3.
NO >> Check wiring to brake fluid level switch.

3. CHECK BRAKE WARNING LAMP 2

Check that the brake warning lamp in the combination meter turns ON/OFF correctly when operating the parking brake.

Is the inspection result normal?

- YES >> GO TO 4.
NO >> Check parking brake switch.

4. CHECK CONNECTOR

1. Turn the ignition switch OFF.
2. Disconnect brake fluid level switch connector and combination meter connector.
3. Check terminal for deformation, disconnection, looseness, etc.

Is the inspection result normal?

- YES >> GO TO 5.
NO >> Replace or repair damaged parts.

5. CHECK BRAKE FLUID LEVEL SWITCH

Check brake fluid level switch. Refer to [BRC-70. "Component Inspection"](#).

Is the inspection result normal?

C1155 BRAKE FLUID LEVEL SWITCH

[VDC/TCS/ABS]

< COMPONENT DIAGNOSIS >

- YES >> GO TO 6.
NO >> Brake fluid level switch is malfunction. Replace reservoir tank.

6.CHECK BRAKE FLUID LEVEL SWITCH CIRCUIT

1. Check the continuity between brake fluid level switch harness connector and combination meter harness connector.

Combination meter		Brake fluid level switch		Continuity
Connector	Terminal	Connector	Terminal	
M34	27	E37	1	Existed

2. Check the continuity between brake fluid level switch harness connector and ground.

Brake fluid level switch		—	Continuity
Connector	Terminal		
E37	2	Ground	Existed

Is the inspection result normal?

- YES >> Replace ABS actuator and electric unit (control unit).
NO >> Repair or replace damaged parts.

Component Inspection

INFOID:000000003247201

1.CHECK BRAKE FLUID LEVEL SWITCH

1. Turn the ignition switch OFF.
2. Disconnect brake fluid level switch connector.
3. Check the continuity between brake fluid level switch connector terminals.

Brake fluid level switch	Condition	Continuity
Terminal		
1 – 2	When brake fluid is full in the reservoir tank.	Not existed
	When brake fluid is empty in the reservoir tank.	Existed

Is the inspection result normal?

- YES >> INSPECTION END
NO >> Proceed to diagnosis procedure. Refer to [BRC-69. "Diagnosis Procedure"](#).

Special Repair Requirement

INFOID:000000003398545

1.AJUSTMENT OF STEERING ANGLE SENSOR NEUTRAL POSITION, CALIBRATION OF YAW RATE/SIDE/DECEL G SENSOR AND CALIBRATION OF PRESSURE SENSOR

After removing/replacing an ABS actuator and electric unit (control unit), be sure to perform the following procedure.

- Adjustment of steering angle sensor neutral position: Refer to [BRC-9. "ADJUSTMENT OF STEERING ANGLE SENSOR NEUTRAL POSITION : Description"](#).
- Calibration of yaw rate/side/decel G sensor: Refer to [BRC-10. "CALIBRATION OF YAW RATE/SIDE/DECEL G SENSOR : Description"](#).
- Calibration of pressure sensor: Refer to [BRC-11. "CALIBRATION OF PRESSURE SENSOR : Description"](#).

>> END

C1160, C1161 INCOMPLETE YAW RATE/SIDE/DECEL G SENSOR CALIBRATION

< COMPONENT DIAGNOSIS >

[VDC/TCS/ABS]

C1160, C1161 INCOMPLETE YAW RATE/SIDE/DECEL G SENSOR CALIBRATION

DTC Logic

INFOID:000000003251900

DTC DETECTION LOGIC

DTC	Display item	Malfunction detected condition	Possible cause
C1160	DECEL G SEN SET	Calibration of yaw rate/side/decel G sensor is not finished.	<ul style="list-style-type: none">• Harness or connector• Yaw rate/side/decel G sensor• ABS actuator and electric unit (control unit)
C1161	SIDE G SEN SET		

DTC CONFIRMATION PROCEDURE

1. DTC REPRODUCTION PROCEDURE

1. Turn the ignition switch ON.
2. Select "DECEL G SEN CALIBRATION" in "WORK SUPPORT", and perform calibration of yaw rate/side/decel G sensor.
3. Perform ABS actuator and electric unit (control unit) self-diagnosis.

Is DTC "C1160" or "C1161" detected?

- YES >> Proceed to diagnosis procedure. Refer to [BRC-71, "Diagnosis Procedure"](#).
NO >> INSPECTION END

Diagnosis Procedure

INFOID:000000003251901

1. CHECK YAW RATE/SIDE/DECEL G SENSOR

Check yaw rate/side/decel G sensor. Refer to [BRC-47, "Component Inspection"](#).

Is the inspection result normal?

- YES >> Replace ABS actuator and electric unit (control unit).
NO >> Repair or replace damaged parts.

Special Repair Requirement

INFOID:000000003406710

1. ADJUSTMENT OF STEERING ANGLE SENSOR NEUTRAL POSITION, CALIBRATION OF YAW RATE/SIDE/DECEL G SENSOR AND CALIBRATION OF PRESSURE SENSOR

- After removing/replacing a yaw rate/side/decel G sensor, be sure to perform the following procedure.
 - Calibration of yaw rate/side/decel G sensor: Refer to [BRC-10, "CALIBRATION OF YAW RATE/SIDE/DECEL G SENSOR : Description"](#).
- After removing/replacing an ABS actuator and electric unit (control unit), be sure to perform the following procedure.
 - Adjustment of steering angle sensor neutral position: Refer to [BRC-9, "ADJUSTMENT OF STEERING ANGLE SENSOR NEUTRAL POSITION : Description"](#).
 - Calibration of yaw rate/side/decel G sensor: Refer to [BRC-10, "CALIBRATION OF YAW RATE/SIDE/DECEL G SENSOR : Description"](#).
 - Calibration of pressure sensor: Refer to [BRC-11, "CALIBRATION OF PRESSURE SENSOR : Description"](#).

>> END

C1162 INCOMPLETE PRESSURE SENSOR CALIBRATION

< COMPONENT DIAGNOSIS >

[VDC/TCS/ABS]

C1162 INCOMPLETE PRESSURE SENSOR CALIBRATION

Description

INFOID:000000004684888

The pressure sensor converts the brake fluid pressure to an electric signal and transmits it to the ABS actuator and electric unit (control unit). [The pressure sensor is integrated in the ABS actuator and electric unit (control unit).]

DTC Logic

INFOID:000000004684885

DTC DETECTION LOGIC

DTC	Display item	Malfunction detected condition	Possible cause
C1162	PRESS SEN SET	Calibration of pressure sensor is not finished.	ABS actuator and electric unit (control unit)

DTC CONFIRMATION PROCEDURE

1. DTC REPRODUCTION PROCEDURE

1. Turn the ignition switch ON.
2. Perform calibration of pressure sensor. Refer to [BRC-11, "CALIBRATION OF PRESSURE SENSOR : Description"](#).
3. Perform ABS actuator and electric unit (control unit) self-diagnosis.

Is DTC "C1162" detected?

- YES >> Proceed to diagnosis procedure. Refer to [BRC-72, "Diagnosis Procedure"](#).
NO >> INSPECTION END

Diagnosis Procedure

INFOID:000000004684886

1. PERFORM PRESSURE SENSOR CALIBRATION

Select "PRESS SEN CALIBRATION" of "WORK SUPPORT". Perform the pressure sensor calibration.

Is pressure sensor calibration completed?

- YES >> INSPECTION END
NO >> GO TO 2.

2. CHECK PRESSURE SENSOR

Check pressure sensor. Refer to [BRC-64, "Diagnosis Procedure"](#).

Is the inspection result normal?

- YES >> Replace ABS actuator and electric unit (control unit).
NO >> Repair or replace error-detected parts.

Special Repair Requirement

INFOID:000000004685075

1. ADJUSTMENT OF STEERING ANGLE SENSOR NEUTRAL POSITION, CALIBRATION OF YAW RATE/SIDE/DECEL G SENSOR AND CALIBRATION OF PRESSURE SENSOR

After removing/replacing an ABS actuator and electric unit (control unit), be sure to perform the following procedure.

- Adjustment of steering angle sensor neutral position: Refer to [BRC-9, "ADJUSTMENT OF STEERING ANGLE SENSOR NEUTRAL POSITION : Description"](#).
- Calibration of yaw rate/side/decel G sensor: Refer to [BRC-10, "CALIBRATION OF YAW RATE/SIDE/DECEL G SENSOR : Description"](#).
- Calibration of pressure sensor: Refer to [BRC-11, "CALIBRATION OF PRESSURE SENSOR : Description"](#).

>> END

C1164, C1165 CV SYSTEM

[VDC/TCS/ABS]

< COMPONENT DIAGNOSIS >

C1164, C1165 CV SYSTEM

Description

INFOID:000000003247202

The cut valve shuts off the normal brake fluid path from the master cylinder, when VDC/TCS is activated.

DTC Logic

INFOID:000000003247203

DTC DETECTION LOGIC

DTC	Display item	Malfunction detected condition	Possible cause
C1164	CV1	VDC switch-over solenoid valve (CV1) on the primary side is open circuit or shorted, or the control line is open or shorted to the power supply or the ground.	<ul style="list-style-type: none"> • Harness or connector • ABS actuator and electric unit (control unit)
C1165	CV2	VDC switch-over solenoid valve (CV2) on the secondary side is open circuit or shorted, or the control line is open or shorted to the power supply or the ground.	

DTC CONFIRMATION PROCEDURE

1. DTC REPRODUCTION PROCEDURE

1. Turn the ignition switch ON.
2. Perform ABS actuator and electric unit (control unit) self-diagnosis.

Is DTC "C1164" or "C1165" detected?

- YES >> Proceed to diagnosis procedure. Refer to [BRC-73, "Diagnosis Procedure"](#).
 NO >> INSPECTION END

Diagnosis Procedure

INFOID:000000003247204

1. CHECK CONNECTOR

1. Turn the ignition switch OFF.
2. Disconnect ABS actuator and electric unit (control unit) connector.
3. Check terminal for deformation, disconnection, looseness, etc.

Is the inspection result normal?

- YES >> GO TO 2.
 NO >> Replace or repair damaged parts.

2. CHECK SOLENOID, VDC SWITCH-OVER VALVE AND ACTUATOR RELAY POWER SUPPLY CIRCUIT

Check the voltage between ABS actuator and electric unit (control unit) harness connector and ground.

ABS actuator and electric unit (control unit)		—	Voltage
Connector	Terminal		
E36	1	Ground	Battery voltage

Is the inspection result normal?

- YES >> GO TO 3.
 NO >> Repair or replace damaged parts.

3. CHECK SOLENOID, VDC SWITCH-OVER VALVE AND ACTUATOR RELAY GROUND CIRCUIT

Check the continuity between ABS actuator and electric unit (control unit) harness connector and ground.

ABS actuator and electric unit (control unit)		—	Continuity
Connector	Terminal		
E36	13	Ground	Existed
	26		

Is the inspection result normal?

- YES >> Replace ABS actuator and electric unit (control unit).
 NO >> Repair or replace damaged parts.

Component Inspection

INFOID:000000003247205

1. CHECK ACTIVE TEST

1. Select each test menu item on "ACTIVE TEST".
2. On the display, touch "Up", "ACT UP", and "ACT KEEP", and check that the system operates as shown in the table below.

Test item	Display item	Display		
		Up	ACT UP	ACT KEEP
FR RH ABS SOLENOID (ACT)	FR RH IN SOL	Off	Off	Off
	FR RH OUT SOL	Off	Off	Off
	CV1	Off	On	On
	SV1	Off	On*	Off
FR LH ABS SOLENOID (ACT)	FR LH IN SOL	Off	Off	Off
	FR LH OUT SOL	Off	Off	Off
	CV2	Off	On	On
	SV2	Off	On*	Off
RR RH ABS SOLENOID (ACT)	RR RH IN SOL	Off	Off	Off
	RR RH OUT SOL	Off	Off	Off
	CV2	Off	On	On
	SV2	Off	On*	Off
RR LH ABS SOLENOID (ACT)	RR LH IN SOL	Off	Off	Off
	RR LH OUT SOL	Off	Off	Off
	CV1	Off	On	On
	SV1	Off	On*	Off

*: On for 1 to 2 seconds after the touch, and then Off.

Is the inspection result normal?

- YES >> INSPECTION END
 NO >> Proceed to diagnosis procedure. Refer to [BRC-73, "Diagnosis Procedure"](#).

Special Repair Requirement

INFOID:000000003398547

1. ADJUSTMENT OF STEERING ANGLE SENSOR NEUTRAL POSITION, CALIBRATION OF YAW RATE/SIDE/DECEL G SENSOR AND CALIBRATION OF PRESSURE SENSOR

After removing/replacing an ABS actuator and electric unit (control unit), be sure to perform the following procedure.

- Adjustment of steering angle sensor neutral position: Refer to [BRC-9, "ADJUSTMENT OF STEERING ANGLE SENSOR NEUTRAL POSITION : Description"](#).
- Calibration of yaw rate/side/decel G sensor: Refer to [BRC-10, "CALIBRATION OF YAW RATE/SIDE/DECEL G SENSOR : Description"](#).
- Calibration of pressure sensor: Refer to [BRC-11, "CALIBRATION OF PRESSURE SENSOR : Description"](#).

>> END

C1166, C1167 SV SYSTEM

Description

INFOID:000000003247206

The suction valve supplies the brake fluid from the master cylinder to the pump, when VDC/TCS is activated.

DTC Logic

INFOID:000000003247207

DTC DETECTION LOGIC

DTC	Display item	Malfunction detected condition	Possible cause
C1166	SV1	VDC switch-over solenoid valve (SV1) on the primary side is open circuit or shorted, or the control line is open or shorted to the power supply or the ground.	<ul style="list-style-type: none"> • Harness or connector • ABS actuator and electric unit (control unit)
C1167	SV2	VDC switch-over solenoid valve (SV2) on the secondary side is open circuit or shorted, or the control line is open or shorted to the power supply or the ground.	

DTC CONFIRMATION PROCEDURE

1. DTC REPRODUCTION PROCEDURE

1. Turn the ignition switch ON.
2. Perform ABS actuator and electric unit (control unit) self-diagnosis.

Is DTC "C1166" or "C1167" detected?

- YES >> Proceed to diagnosis procedure. Refer to [BRC-75, "Diagnosis Procedure"](#).
 NO >> INSPECTION END

Diagnosis Procedure

INFOID:000000003398549

1. CHECK CONNECTOR

1. Turn the ignition switch OFF.
2. Disconnect ABS actuator and electric unit (control unit) connector.
3. Check terminal for deformation, disconnection, looseness, etc.

Is the inspection result normal?

- YES >> GO TO 2.
 NO >> Replace or repair damaged parts.

2. CHECK SOLENOID, VDC SWITCH-OVER VALVE AND ACTUATOR RELAY POWER SUPPLY CIRCUIT

Check the voltage between ABS actuator and electric unit (control unit) harness connector and ground.

ABS actuator and electric unit (control unit)		—	Voltage
Connector	Terminal		
E36	1	Ground	Battery voltage

Is the inspection result normal?

- YES >> GO TO 3.
 NO >> Repair or replace damaged parts.

3. CHECK SOLENOID, VDC SWITCH-OVER VALVE AND ACTUATOR RELAY GROUND CIRCUIT

Check the continuity between ABS actuator and electric unit (control unit) harness connector and ground.

ABS actuator and electric unit (control unit)		—	Continuity
Connector	Terminal		
E36	13	Ground	Existed
	26		

Is the inspection result normal?

< COMPONENT DIAGNOSIS >

- YES >> Replace ABS actuator and electric unit (control unit).
- NO >> Repair or replace damaged parts.

Component Inspection

INFOID:000000003398550

1. CHECK ACTIVE TEST

1. Select each test menu item on "ACTIVE TEST".
2. On the display, touch "Up", "ACT UP", and "ACT KEEP", and check that the system operates as shown in the table below.

Test item	Display item	Display		
		Up	ACT UP	ACT KEEP
FR RH ABS SOLENOID (ACT)	FR RH IN SOL	Off	Off	Off
	FR RH OUT SOL	Off	Off	Off
	CV1	Off	On	On
	SV1	Off	On*	Off
FR LH ABS SOLENOID (ACT)	FR LH IN SOL	Off	Off	Off
	FR LH OUT SOL	Off	Off	Off
	CV2	Off	On	On
	SV2	Off	On*	Off
RR RH ABS SOLENOID (ACT)	RR RH IN SOL	Off	Off	Off
	RR RH OUT SOL	Off	Off	Off
	CV2	Off	On	On
	SV2	Off	On*	Off
RR LH ABS SOLENOID (ACT)	RR LH IN SOL	Off	Off	Off
	RR LH OUT SOL	Off	Off	Off
	CV1	Off	On	On
	SV1	Off	On*	Off

*: On for 1 to 2 seconds after the touch, and then Off.

Is the inspection result normal?

- YES >> INSPECTION END
- NO >> Proceed to diagnosis procedure. Refer to [BRC-75, "Diagnosis Procedure"](#).

Special Repair Requirement

INFOID:000000003398548

1. ADJUSTMENT OF STEERING ANGLE SENSOR NEUTRAL POSITION, CALIBRATION OF YAW RATE/SIDE/DECEL G SENSOR AND CALIBRATION OF PRESSURE SENSOR

After removing/replacing an ABS actuator and electric unit (control unit), be sure to perform the following procedure.

- Adjustment of steering angle sensor neutral position: Refer to [BRC-9, "ADJUSTMENT OF STEERING ANGLE SENSOR NEUTRAL POSITION : Description"](#).
- Calibration of yaw rate/side/decel G sensor: Refer to [BRC-10, "CALIBRATION OF YAW RATE/SIDE/DECEL G SENSOR : Description"](#).
- Calibration of pressure sensor: Refer to [BRC-11, "CALIBRATION OF PRESSURE SENSOR : Description"](#).

>> END

U1000, U1002 CAN COMM CIRCUIT

< COMPONENT DIAGNOSIS >

[VDC/TCS/ABS]

U1000, U1002 CAN COMM CIRCUIT

Description

INFOID:000000003247214

CAN (Controller Area Network) is a serial communication line for real time application. It is an on-vehicle multiplex communication line with high data communication speed and excellent error detection ability. Many electronic control units are equipped onto a vehicle, and each control unit shares information and links with other control units during operation (not independent). In CAN communication, control units are connected with 2 communication lines (CAN-H line, CAN-L line) allowing a high rate of information transmission with less wiring. Each control unit transmits/receives data but selectively reads required data only.

DTC Logic

INFOID:000000003247215

DTC DETECTION LOGIC

DTC	Display item	Malfunction detected condition	Possible cause
U1000	CAN COMM CIRCUIT	When ABS actuator and electric unit (control unit) is not transmitting or receiving CAN communication signal for 2 seconds or more.	<ul style="list-style-type: none">CAN communication lineABS actuator and electric unit (control unit)
U1002	SYSTEM COOM	When ABS actuator and electric unit (control unit) is not transmitting or receiving CAN communication signal for 2 seconds or less.	

A

B

C

D

E

BRC

G

DTC CONFIRMATION PROCEDURE

1. DTC REPRODUCTION PROCEDURE

- Turn the ignition switch ON.
- Perform ABS actuator and electric unit (control unit) self-diagnosis.

Is DTC "U1000" or "U1002" detected?

- YES >> Proceed to diagnosis procedure. Refer to [BRC-77, "Diagnosis Procedure"](#).
NO >> INSPECTION END

H

I

J

Diagnosis Procedure

INFOID:000000003247216

1. CHECK CONNECTOR

- Turn the ignition switch OFF.
- Disconnect ABS actuator and electric unit (control unit) connector.
- Check terminal for deformation, disconnection, looseness, etc.

Is the inspection result normal?

- YES >> INSPECTION END
NO >> Proceed to diagnosis procedure. Refer to [LAN-25, "CAN System Specification Chart"](#).

K

L

M

Special Repair Requirement

INFOID:000000003398551

1. ADJUSTMENT OF STEERING ANGLE SENSOR NEUTRAL POSITION, CALIBRATION OF YAW RATE/SIDE/DECEL G SENSOR AND CALIBRATION OF PRESSURE SENSOR

After removing/replacing an ABS actuator and electric unit (control unit), be sure to perform the following procedure.

- Adjustment of steering angle sensor neutral position: Refer to [BRC-9, "ADJUSTMENT OF STEERING ANGLE SENSOR NEUTRAL POSITION : Description"](#).
- Calibration of yaw rate/side/decel G sensor: Refer to [BRC-10, "CALIBRATION OF YAW RATE/SIDE/DECEL G SENSOR : Description"](#).
- Calibration of pressure sensor: Refer to [BRC-11, "CALIBRATION OF PRESSURE SENSOR : Description"](#).

N

O

P

>> END

POWER SUPPLY AND GROUND CIRCUIT

< COMPONENT DIAGNOSIS >

[VDC/TCS/ABS]

POWER SUPPLY AND GROUND CIRCUIT

Description

INFOID:000000003736972

Supplies power to ABS actuator and electric unit (control unit).

Diagnosis Procedure

INFOID:000000003736973

1. CHECK ABS ACTUATOR AND ELECTRIC UNIT (CONTROL UNIT) IGNITION POWER SUPPLY

1. Turn the ignition switch OFF.
2. Disconnect ABS actuator and electric unit (control unit) harness connector.
3. Check the voltage between ABS actuator and electric unit (control unit) harness connector and ground.

ABS actuator and electric unit (control unit)		—	Voltage (Approx.)
Connector	Terminal		
E36	20	Ground	0 V

4. Turn the ignition switch ON.
CAUTION:
Never start the engine.
5. Check the voltage between ABS actuator and electric unit (control unit) harness connector and ground.

ABS actuator and electric unit (control unit)		—	Voltage
Connector	Terminal		
E36	20	Ground	Battery voltage

Is the inspection result normal?

YES >> GO TO 2.

NO >> Perform the trouble diagnosis for power supply circuit.

2. CHECK ABS ACTUATOR AND ELECTRIC UNIT (CONTROL UNIT) POWER SUPPLY

1. Turn the ignition switch OFF.
2. Check the voltage between ABS actuator and electric unit (control unit) harness connector and ground.

ABS actuator and electric unit (control unit)		—	Voltage
Connector	Terminal		
E36	1	Ground	Battery voltage

3. Turn the ignition switch ON.
CAUTION:
Never start the engine.
4. Check the voltage between ABS actuator and electric unit (control unit) harness connector and ground.

ABS actuator and electric unit (control unit)		—	Voltage
Connector	Terminal		
E36	1	Ground	Battery voltage

Is the inspection result normal?

YES >> GO TO 3.

NO >> Perform the trouble diagnosis for power supply circuit.

3. CHECK ABS ACTUATOR AND ELECTRIC UNIT (CONTROL UNIT) GROUND

1. Turn the ignition switch OFF.
2. Check the continuity between ABS actuator and electric unit (control unit) harness connector and ground.

POWER SUPPLY AND GROUND CIRCUIT

< COMPONENT DIAGNOSIS >

[VDC/TCS/ABS]

ABS actuator and electric unit (control unit)		—	Continuity
Connector	Terminal		
E36	13	Ground	Existed
	26		

Is the inspection result normal?

YES >> INSPECTION END

NO >> Repair or replace damaged parts.

A

B

C

D

E

BRC

G

H

I

J

K

L

M

N

O

P

PARKING BRAKE SWITCH

< COMPONENT DIAGNOSIS >

[VDC/TCS/ABS]

PARKING BRAKE SWITCH

Component Function Check

INFOID:000000003247221

1.CHECK PARKING BRAKE SWITCH OPERATION

Operate the parking brake pedal. Then check that the brake warning lamp in the combination meter turns ON/OFF correctly.

Condition	Brake warning lamp illumination status
When the parking brake pedal is operation	ON
When the parking brake pedal is not operation.	OFF

Is the inspection result normal?

YES >> INSPECTION END

NO >> Proceed to diagnosis procedure. Refer to [BRC-80, "Diagnosis Procedure"](#).

Diagnosis Procedure

INFOID:000000003247222

1.CHECK PARKING BRAKE SWITCH

Check parking brake switch. Refer to [BRC-80, "Component Inspection"](#).

Is the inspection result normal?

YES >> GO TO 2.

NO >> Replace parking brake switch.

2.CHECK COMBINATION METER

Check the indication and operation of combination meter are normal. Refer to [MWI-33, "Diagnosis Description"](#).

Is the inspection result normal?

YES >> GO TO 3.

NO >> Check combination meter. Refer to [MWI-33, "Diagnosis Description"](#).

3.CHECK PARKING BRAKE SWITCH CIRCUIT

1. Turn ignition switch OFF.
2. Disconnect parking brake switch connector.
3. Disconnect combination meter connector.
4. Check the continuity between parking brake switch harness connector and combination meter harness connector.

Parking brake switch		Combination meter		Continuity
Connector	Terminal	Connector	Terminal	
E27	1	M34	26	Existed

Is the inspection result normal?

YES >> INSPECTION END

NO >> Repair or replace damaged parts.

Component Inspection

INFOID:000000003247223

1.CHECK PARKING BRAKE SWITCH

1. Turn the ignition switch OFF.
2. Disconnect parking brake switch connector.
3. Check the continuity between parking brake switch connector and ground.

PARKING BRAKE SWITCH

< COMPONENT DIAGNOSIS >

[VDC/TCS/ABS]

Parking brake switch		—	Condition	Continuity
Connector	Terminal			
E27	1	Ground	When the parking brake switch is operated.	Existed
			When the parking brake switch is not operated.	Not existed

Is the inspection result normal?

YES >> INSPECTION END

NO >> Replace parking brake switch. Refer to [PB-6. "Exploded View"](#).

A
B
C
D
E
G
H
I
J
K
L
M
N
O
P

BRC

VDC OFF SWITCH

< COMPONENT DIAGNOSIS >

[VDC/TCS/ABS]

VDC OFF SWITCH

Description

INFOID:000000003247224

VDC OFF switch can deactivate (turn OFF) the VDC/TCS function by pressing the VDC OFF switch.

Component Function Check

INFOID:000000003247225

1. CHECK VDC OFF SWITCH OPERATION

Turn ON/OFF the VDC OFF switch and check that the VDC OFF indicator lamp in the combination meter turns ON/OFF correctly.

Condition	VDC OFF indicator lamp illumination status
Press the VDC OFF switch when VDC OFF indicator lamp is OFF.	ON
Press the VDC OFF switch when VDC OFF indicator lamp is ON.	OFF

Is the inspection result normal?

YES >> INSPECTION END

NO >> Proceed to diagnosis procedure. Refer to [BRC-82. "Diagnosis Procedure"](#).

Diagnosis Procedure

INFOID:000000003247226

1. CHECK VDC OFF SWITCH

Check VDC OFF switch. Refer to [BRC-83. "Component Inspection"](#).

Is the inspection result normal?

YES >> GO TO 2.

NO >> Replace VDC OFF switch.

2. CHECK VDC OFF SWITCH HARNESS

1. Disconnect ABS actuator and electric unit (control unit) connector.
2. Disconnect VDC OFF switch connector.
3. Check the continuity between VDC OFF switch harness connector and ABS actuator and electric unit (control unit) harness connector.

ABS actuator and electric unit (control unit)		VDC OFF switch		Continuity
Connector	Terminal	Connector	Terminal	
E36	22	M5	1	Existed

4. Check the continuity between ABS actuator and electric unit (control unit) harness connector and ground.

ABS actuator and electric unit (control unit)		—	Continuity
Connector	Terminal		
E36	22	Ground	Not existed

5. Check the continuity between VDC OFF switch harness connector and ground.

VDC OFF switch		—	Continuity
Connector	Terminal		
M5	2	Ground	Existed

Is the inspection result normal?

YES >> GO TO 3.

NO >> Repair or replace damaged parts.

VDC OFF SWITCH

< COMPONENT DIAGNOSIS >

[VDC/TCS/ABS]

3.CHECK COMBINATION METER

1. Connect ABS actuator and electric unit (control unit) connector.
2. Connect VDC OFF switch connector.
3. Check the indication and operation of combination meter are normal. Refer to [MWI-33. "Diagnosis Description"](#).

Is the inspection result normal?

YES >> INSPECTION END

NO >> Repair or replace combination meter.

Component Inspection

INFOID:000000003247227

1.CHECK VDC OFF SWITCH

1. Turn the ignition switch OFF.
2. Disconnect VDC OFF switch connector.
3. Check the continuity between VDC OFF switch connector terminals.

VDC OFF switch	Condition	
Terminal		
1 - 2	When VDC OFF switch is hold pressed.	Existed
	When releasing VDC OFF switch.	Not existed

Is the inspection result normal?

YES >> INSPECTION END

NO >> Replace VDC OFF switch.

A
B
C
D
E
G
H
I
J
K
L
M
N
O
P

BRC

ABS WARNING LAMP

< COMPONENT DIAGNOSIS >

[VDC/TCS/ABS]

ABS WARNING LAMP

Description

INFOID:000000003247228

×: ON –: OFF

Condition	ABS warning lamp
Ignition switch OFF	–
For 2 seconds after turning ignition switch ON	×
2 seconds later after turning ignition switch ON	–
ABS function is malfunctioning.	×
EBD function is malfunctioning.	×

Component Function Check

INFOID:000000003247229

1.CHECK ABS WARNING LAMP OPERATION

Check that the lamp illuminates for approximately 2 seconds after the ignition switch is turned ON.

Is the inspection result normal?

YES >> INSPECTION END

NO >> Proceed to diagnosis procedure. Refer to [BRC-84, "Diagnosis Procedure"](#).

Diagnosis Procedure

INFOID:000000003247230

1.CHECK SELF-DIAGNOSIS

Perform ABS actuator and electric unit (control unit) self-diagnosis.

Is the inspection result normal?

YES >> GO TO 2.

NO >> Check items displayed by self-diagnosis.

2.CHECK COMBINATION METER

Check the indication and operation of combination meter are normal. Refer to [MWI-33, "Diagnosis Description"](#).

Is the inspection result normal?

YES >> Replace ABS actuator and electric unit (control unit).

NO >> Repair or replace combination meter.

BRAKE WARNING LAMP

< COMPONENT DIAGNOSIS >

[VDC/TCS/ABS]

BRAKE WARNING LAMP

Description

INFOID:000000003247231

×: ON –: OFF

Condition	Brake warning lamp (Note 1)
Ignition switch OFF	–
For 2 seconds after turning ignition switch ON	× (Note 2)
2 seconds later after turning ignition switch ON	× (Note 2)
EBD function is malfunctioning.	×

NOTE:

- 1: Brake warning lamp will turn on in case of parking brake operation (when switch is ON) or of brake fluid level switch operation (when brake fluid is insufficient).
- 2: After starting the engine, brake warning lamp is turned off.

Component Function Check

INFOID:000000003247232

BRC

1. BRAKE WARNING LAMP OPERATION CHECK 1

Check that the lamp illuminates for approximately 2 seconds after the ignition switch is turned ON.

Is the inspection result normal?

YES >> GO TO 2.

NO >> Proceed to diagnosis procedure. Refer to [BRC-85, "Diagnosis Procedure"](#).

2. BRAKE WARNING LAMP OPERATION CHECK 2

Check that the brake warning lamp in the combination meter turns ON/OFF correctly when operating the parking brake pedal.

Is the inspection result normal?

YES >> INSPECTION END

NO >> Check parking brake switch. Refer to [BRC-80, "Diagnosis Procedure"](#).

Diagnosis Procedure

INFOID:000000003247233

1. CHECK PARKING BRAKE SWITCH

Check that the brake warning lamp in the combination meter turns ON/OFF correctly when operating the parking brake pedal.

Is the inspection result normal?

YES >> GO TO 2.

NO >> Check parking brake switch. Refer to [BRC-80, "Diagnosis Procedure"](#).

2. CHECK SELF-DIAGNOSIS

Perform ABS actuator and electric unit (control unit) self-diagnosis.

Is the inspection result normal?

YES >> GO TO 3.

NO >> Check items displayed by self-diagnosis.

3. CHECK COMBINATION METER

Check the indication and operation of combination meter are normal. Refer to [MWI-33, "Diagnosis Description"](#).

Is the inspection result normal?

YES >> Replace ABS actuator and electric unit (control unit).

NO >> Repair or replace combination meter.

VDC OFF INDICATOR LAMP

< COMPONENT DIAGNOSIS >

[VDC/TCS/ABS]

VDC OFF INDICATOR LAMP

Description

INFOID:000000003247234

×: ON –: OFF

Condition	VDC OFF indicator lamp
Ignition switch OFF	–
For 2 seconds after turning ignition switch ON	×
2 seconds later after turning ignition switch ON	–
VDC OFF switch turned ON. (VDC function is OFF.)	×
VDC/TCS function is malfunctioning.	×
ABS function is malfunctioning.	×
EBD function is malfunctioning.	×

Component Function Check

INFOID:000000003247235

1.VDC OFF INDICATOR LAMP OPERATION CHECK 1

Check that the lamp illuminates for approximately 2 seconds after the ignition switch is turned ON.

Is the inspection result normal?

YES >> GO TO 2.

NO >> Proceed to diagnosis procedure. Refer to [BRC-86. "Diagnosis Procedure"](#).

2.VDC OFF INDICATOR LAMP OPERATION CHECK 2

Check that the VDC OFF indicator lamp in the combination meter turns ON/OFF correctly when operating the VDC OFF switch.

Is the inspection result normal?

YES >> INSPECTION END

NO >> Check VDC OFF switch. Refer to [BRC-82. "Diagnosis Procedure"](#).

Diagnosis Procedure

INFOID:000000003247236

1.CHECK VDC OFF SWITCH

Perform the trouble diagnosis for VDC OFF switch. Refer to [BRC-82. "Diagnosis Procedure"](#).

Is the inspection result normal?

YES >> GO TO 2.

NO >> Check VDC OFF switch. Refer to [BRC-82. "Diagnosis Procedure"](#).

2.CHECK SELF-DIAGNOSIS

Perform ABS actuator and electric unit (control unit) self-diagnosis.

Is the inspection result normal?

YES >> GO TO 3.

NO >> Check items displayed by self-diagnosis.

3.CHECK COMBINATION METER

Check the indication and operation of combination meter are normal. Refer to [MWI-33. "Diagnosis Description"](#).

Is the inspection result normal?

YES >> Replace ABS actuator and electric unit (control unit).

NO >> Repair or replace combination meter.

SLIP INDICATOR LAMP

< COMPONENT DIAGNOSIS >

[VDC/TCS/ABS]

SLIP INDICATOR LAMP

Description

INFOID:000000003247237

×: ON △: Blink -: OFF

Condition	SLIP indicator lamp
Ignition switch OFF	-
For 2 seconds after turning ignition switch ON	×
2 seconds later after turning ignition switch ON	-
VDC/TCS is activated while driving.	△
VDC/TCS function is malfunctioning.	×
ABS function is malfunctioning.	×
EBD function is malfunctioning.	×

Component Function Check

INFOID:000000003247238

1.CHECK SLIP INDICATOR LAMP OPERATION

Check that the lamp illuminates for approximately 2 seconds after the ignition switch is turned ON.

Is the inspection result normal?

YES >> INSPECTION END

NO >> Proceed to diagnosis procedure. Refer to [BRC-87, "Diagnosis Procedure"](#).

Diagnosis Procedure

INFOID:000000003247239

1.CHECK SELF-DIAGNOSIS

Perform ABS actuator and electric unit (control unit) self-diagnosis.

Is the inspection result normal?

YES >> GO TO 2.

NO >> Check items displayed by self-diagnosis.

2.CHECK COMBINATION METER

Check the indication and operation of combination meter are normal. Refer to [MWI-33, "Diagnosis Description"](#).

Is the inspection result normal?

YES >> Replace ABS actuator and electric unit (control unit).

NO >> Repair or replace combination meter.

A
B
C
D
E
G
H
I
J
K
L
M
N
O
P

BRC

ABS ACTUATOR AND ELECTRIC UNIT (CONTROL UNIT)

< ECU DIAGNOSIS >

[VDC/TCS/ABS]

ECU DIAGNOSIS

ABS ACTUATOR AND ELECTRIC UNIT (CONTROL UNIT)

Reference Value

INFOID:000000003247240

VALUES ON THE DIAGNOSIS TOOL

CAUTION:

The display shows the control unit calculation data, so a normal value might be displayed even in the event the output circuit (harness) is open or short-circuited.

Monitor item	Display content	Data monitor	
		Condition	Reference value in normal operation
FR LH SENSOR	Wheel speed	Vehicle stopped	0 [km/h (MPH)]
		Vehicle running (Note 1)	Nearly matches the speedometer display ($\pm 10\%$ or less)
FR RH SENSOR	Wheel speed	Vehicle stopped	0 [km/h (MPH)]
		Vehicle running (Note 1)	Nearly matches the speedometer display ($\pm 10\%$ or less)
RR LH SENSOR	Wheel speed	Vehicle stopped	0 [km/h (MPH)]
		Vehicle running (Note 1)	Nearly matches the speedometer display ($\pm 10\%$ or less)
RR RH SENSOR	Wheel speed	Vehicle stopped	0 [km/h (MPH)]
		Vehicle running (Note 1)	Nearly matches the speedometer display ($\pm 10\%$ or less)
STOP LAMP SW	Brake pedal operation	When brake pedal is depressed	On
		When brake pedal is not depressed	Off
BATTERY VOLT	Battery voltage supplied to the ABS actuator and electric unit (control unit)	Ignition switch ON	10 – 16 V
SLCT LVR POSI	Select shift position	CVT shift position (P, R, N, D, L)	P R N D L
		Manual mode	##
OFF SW	VDC OFF switch ON/OFF status	VDC OFF switch ON (When VDC OFF indicator lamp is ON)	On
		VDC OFF switch OFF (When VDC OFF indicator lamp is OFF)	Off
YAW RATE SEN	Yaw rate detected by yaw rate/side/decel sensor	Vehicle stopped	Approx. 0 d/s
		Vehicle running	-100 to 100 d/s
DECEL G-SEN	Decel G detected by yaw rate/side/decel G sensor	Vehicle stopped	Approx. 0 G
		Vehicle running	-1.7 – +1.7 G
ACCEL POS SIG	Open/Close condition of throttle valve (Linked with accelerator pedal)	Accelerator pedal not depressed (Engine stopped)	0 %
		Depress accelerator pedal (Engine stopped)	0 - 100 %

ABS ACTUATOR AND ELECTRIC UNIT (CONTROL UNIT)

< ECU DIAGNOSIS >

[VDC/TCS/ABS]

Monitor item	Display content	Data monitor		
		Condition	Reference value in normal operation	
SIDE G-SENSOR	Transverse G detected by yaw rate/side/decel G sensor	Vehicle stopped	Approx. 0 m/s ²	A
		Vehicle running	- 16.7 - 16.7 m/s ²	B
STR ANGLE SIG	Steering angle detected by steering angle sensor	Driving straight	-3.5 - +3.5°	C
		Turn 90 ° to right	Approx. -90 °	
		Turn 90 ° to left	Approx. +90 °	
ENGINE SPEED	With engine running	With engine stopped	0 [tr/min (rpm)]	D
		Engine running	Almost in accordance with tachometer display	E
FLUID LEV SW	Brake fluid level switch signal status	When brake fluid level switch ON	On	F
		When brake fluid level switch OFF	Off	
FR RH IN SOL	Operation status of each solenoid valve	Actuator (solenoid valve) is active ("ACTIVE TEST" with CONSULT-III)	On	BRC
		When the actuator (solenoid valve) is not active and actuator relay is active (ignition switch ON)	Off	G
FR RH OUT SOL	Operation status of each solenoid valve	Actuator (solenoid valve) is active ("ACTIVE TEST" with CONSULT-III)	On	H
		When the actuator (solenoid valve) is not active and actuator relay is active (ignition switch ON)	Off	I
FR LH IN SOL	Operation status of each solenoid valve	Actuator (solenoid valve) is active ("ACTIVE TEST" with CONSULT-III)	On	J
		When the actuator (solenoid valve) is not active and actuator relay is active (ignition switch ON)	Off	K
FR LH OUT SOL	Operation status of each solenoid valve	Actuator (solenoid valve) is active ("ACTIVE TEST" with CONSULT-III)	On	L
		When the actuator (solenoid valve) is not active and actuator relay is active (ignition switch ON)	Off	M
RR RH IN SOL	Operation status of each solenoid valve	Actuator (solenoid valve) is active ("ACTIVE TEST" with CONSULT-III)	On	N
		When the actuator (solenoid valve) is not active and actuator relay is active (ignition switch ON)	Off	O
RR RH OUT SOL	Operation status of each solenoid valve	Actuator (solenoid valve) is active ("ACTIVE TEST" with CONSULT-III)	On	P
		When the actuator (solenoid valve) is not active and actuator relay is active (ignition switch ON)	Off	
RR LH IN SOL	Operation status of each solenoid valve	Actuator (solenoid valve) is active ("ACTIVE TEST" with CONSULT-III)	On	
		When the actuator (solenoid valve) is not active and actuator relay is active (ignition switch ON)	Off	
RR LH OUT SOL	Operation status of each solenoid valve	Actuator (solenoid valve) is active ("ACTIVE TEST" with CONSULT-III)	On	
		When the actuator (solenoid valve) is not active and actuator relay is active (ignition switch ON)	Off	

ABS ACTUATOR AND ELECTRIC UNIT (CONTROL UNIT)

< ECU DIAGNOSIS >

[VDC/TCS/ABS]

Monitor item	Display content	Data monitor	
		Condition	Reference value in normal operation
MOTOR RELAY	Motor and motor relay operation	Ignition switch ON or engine running (ABS operated)	On
		Ignition switch ON or engine running (ABS not operated)	Off
ACTUATOR RLY	Actuator relay operation	Vehicle stopped (Engine running)	On
		Vehicle stopped (Ignition switch ON)	Off
ABS WARN LAMP	ABS warning lamp (Note 2)	When ABS warning lamp is ON	On
		When ABS warning lamp is OFF	Off
OFF LAMP	VDC OFF indicator lamp (Note 2)	When VDC OFF indicator lamp is ON	On
		When VDC OFF indicator lamp is OFF	Off
SLIP LAMP	SLIP indicator lamp (Note 2)	When SLIP indicator lamp is ON	On
		When SLIP indicator lamp is blinking	
		When SLIP indicator lamp is OFF	Off
EBD SIGNAL	EBD operation	EBD is active	On
		EBD is inactive	Off
ABS SIGNAL	ABS operation	ABS is active	On
		ABS is inactive	Off
TCS SIGNAL	TCS operation	TCS is active	On
		TCS is inactive	Off
VDC SIGNAL	VDC operation	VDC is active	On
		VDC is inactive	Off
EBD FAIL SIG	EBD fail-safe signal	In EBD fail-safe	On
		EBD is normal	Off
ABS FAIL SIG	ABS fail-safe signal	In ABS fail-safe	On
		ABS is normal	Off
TCS FAIL SIG	TCS fail-safe signal	In TCS fail-safe	On
		TCS is normal	Off
VDC FAIL SIG	VDC fail-safe signal	In VDC fail-safe	On
		VDC is normal	Off
CV1	Operation status of each solenoid valve	Actuator (solenoid valve) is active ("ACTIVE TEST" with CONSULT-III)	On
		When the actuator (solenoid valve) is not active and actuator relay is active (ignition switch ON)	Off
CV2	Operation status of each solenoid valve	Actuator (solenoid valve) is active ("ACTIVE TEST" with CONSULT-III)	On
		When the actuator (solenoid valve) is not active and actuator relay is active (ignition switch ON)	Off
SV1	Operation status of each solenoid valve	Actuator (solenoid valve) is active ("ACTIVE TEST" with CONSULT-III)	On
		When the actuator (solenoid valve) is not active and actuator relay is active (ignition switch ON)	Off

ABS ACTUATOR AND ELECTRIC UNIT (CONTROL UNIT)

< ECU DIAGNOSIS >

[VDC/TCS/ABS]

Monitor item	Display content	Data monitor	
		Condition	Reference value in normal operation
SV2	Operation status of each solenoid valve	Actuator (solenoid valve) is active ("ACTIVE TEST" with CONSULT-III)	On
		When the actuator (solenoid valve) is not active and actuator relay is active (ignition switch ON)	Off
PRESS SENSOR	Brake fluid pressure detected by pressure sensor	With ignition switch ON and brake pedal released	Approx. 0 bar
		With ignition switch ON and brake pedal depressed	0 – 170 bar
EBD WARN LAMP	Brake warning lamp (Note 2, Note 3)	When brake warning lamp is ON	On
		When brake warning lamp is OFF	Off
4WD FAIL REQ	ETS fail status	ETS fail	On
		ETS normal	Off
2WD/4WD	Drive axle	2WD model	2WD
		AWD model	4WD

NOTE:

- 1: Confirm tire pressure is normal.
- 2: On and off timing for warning lamp and indicator lamp.
- ABS warning lamp: Refer to [BRC-84, "Description"](#).
- Brake warning lamp: Refer to [BRC-85, "Description"](#).
- VDC OFF indicator lamp: Refer to [BRC-86, "Description"](#).
- SLIP indicator lamp: Refer to [BRC-87, "Description"](#).
- 3: Serves as EBD warning lamp.

Wiring Diagram -BRAKE CONTROL SYSTEM-

INFOID:000000003247241

UP TO VIN: JN8AZ18U*9W100000, JN8AZ18W*9W200000 (EXCEPT FOR MEXICO),
 JN8AZ18U*9W710000, JN8AZ18W*9W810000 (FOR MEXICO)











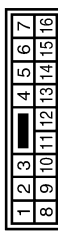

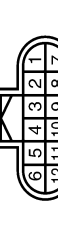

A
B
C
D
E
BRC
G
H
I
J
K
L
M
N
O
P

ABS ACTUATOR AND ELECTRIC UNIT (CONTROL UNIT)

< ECU DIAGNOSIS >

[VDC/TCS/ABS]

BRAKE CONTROL SYSTEM (TYPE A)

<table border="1"> <tr><td>Connector No.</td><td>B4</td></tr> <tr><td>Connector Name</td><td>WIRE TO WIRE</td></tr> <tr><td>Connector Type</td><td>NS16MW-ZS</td></tr> </table>   <table border="1"> <tr><th>Terminal No.</th><th>Color of Wire</th><th>Signal Name [Specification]</th></tr> <tr><td>13</td><td>P</td><td>-</td></tr> <tr><td>14</td><td>BR</td><td>-</td></tr> <tr><td>15</td><td>O</td><td>-</td></tr> <tr><td>16</td><td>G</td><td>-</td></tr> </table>	Connector No.	B4	Connector Name	WIRE TO WIRE	Connector Type	NS16MW-ZS	Terminal No.	Color of Wire	Signal Name [Specification]	13	P	-	14	BR	-	15	O	-	16	G	-	<table border="1"> <tr><td>Connector No.</td><td>B12</td></tr> <tr><td>Connector Name</td><td>WIRE TO WIRE</td></tr> <tr><td>Connector Type</td><td>NS16FW-CS</td></tr> </table>   <table border="1"> <tr><th>Terminal No.</th><th>Color of Wire</th><th>Signal Name [Specification]</th></tr> <tr><td>7</td><td>O</td><td>-</td></tr> <tr><td>8</td><td>G</td><td>-</td></tr> <tr><td>9</td><td>BR</td><td>-</td></tr> <tr><td>10</td><td>P</td><td>-</td></tr> <tr><td>11</td><td>P</td><td>-</td></tr> </table>	Connector No.	B12	Connector Name	WIRE TO WIRE	Connector Type	NS16FW-CS	Terminal No.	Color of Wire	Signal Name [Specification]	7	O	-	8	G	-	9	BR	-	10	P	-	11	P	-	<table border="1"> <tr><td>Connector No.</td><td>B205</td></tr> <tr><td>Connector Name</td><td>WIRE TO WIRE</td></tr> <tr><td>Connector Type</td><td>RH12FB</td></tr> </table>   <table border="1"> <tr><th>Terminal No.</th><th>Color of Wire</th><th>Signal Name [Specification]</th></tr> <tr><td>1</td><td>W</td><td>-</td></tr> <tr><td>3</td><td>V</td><td>-</td></tr> <tr><td>7</td><td>B</td><td>-</td></tr> <tr><td>9</td><td>P</td><td>-</td></tr> </table>	Connector No.	B205	Connector Name	WIRE TO WIRE	Connector Type	RH12FB	Terminal No.	Color of Wire	Signal Name [Specification]	1	W	-	3	V	-	7	B	-	9	P	-	<table border="1"> <tr><td>Connector No.</td><td>B206</td></tr> <tr><td>Connector Name</td><td>WIRE TO WIRE</td></tr> <tr><td>Connector Type</td><td>NS16MW-CS</td></tr> </table>   <table border="1"> <tr><th>Terminal No.</th><th>Color of Wire</th><th>Signal Name [Specification]</th></tr> <tr><td>8</td><td>B</td><td>-</td></tr> <tr><td>9</td><td>W</td><td>-</td></tr> <tr><td>10</td><td>V</td><td>-</td></tr> <tr><td>11</td><td>P</td><td>-</td></tr> </table>	Connector No.	B206	Connector Name	WIRE TO WIRE	Connector Type	NS16MW-CS	Terminal No.	Color of Wire	Signal Name [Specification]	8	B	-	9	W	-	10	V	-	11	P	-
Connector No.	B4																																																																																									
Connector Name	WIRE TO WIRE																																																																																									
Connector Type	NS16MW-ZS																																																																																									
Terminal No.	Color of Wire	Signal Name [Specification]																																																																																								
13	P	-																																																																																								
14	BR	-																																																																																								
15	O	-																																																																																								
16	G	-																																																																																								
Connector No.	B12																																																																																									
Connector Name	WIRE TO WIRE																																																																																									
Connector Type	NS16FW-CS																																																																																									
Terminal No.	Color of Wire	Signal Name [Specification]																																																																																								
7	O	-																																																																																								
8	G	-																																																																																								
9	BR	-																																																																																								
10	P	-																																																																																								
11	P	-																																																																																								
Connector No.	B205																																																																																									
Connector Name	WIRE TO WIRE																																																																																									
Connector Type	RH12FB																																																																																									
Terminal No.	Color of Wire	Signal Name [Specification]																																																																																								
1	W	-																																																																																								
3	V	-																																																																																								
7	B	-																																																																																								
9	P	-																																																																																								
Connector No.	B206																																																																																									
Connector Name	WIRE TO WIRE																																																																																									
Connector Type	NS16MW-CS																																																																																									
Terminal No.	Color of Wire	Signal Name [Specification]																																																																																								
8	B	-																																																																																								
9	W	-																																																																																								
10	V	-																																																																																								
11	P	-																																																																																								
<table border="1"> <tr><td>Connector No.</td><td>C2</td></tr> <tr><td>Connector Name</td><td>WIRE TO WIRE</td></tr> <tr><td>Connector Type</td><td>RH12MB</td></tr> </table>   <table border="1"> <tr><th>Terminal No.</th><th>Color of Wire</th><th>Signal Name [Specification]</th></tr> <tr><td>1</td><td>L</td><td>-</td></tr> <tr><td>3</td><td>V</td><td>-</td></tr> <tr><td>7</td><td>R</td><td>-</td></tr> <tr><td>9</td><td>P</td><td>-</td></tr> </table>	Connector No.	C2	Connector Name	WIRE TO WIRE	Connector Type	RH12MB	Terminal No.	Color of Wire	Signal Name [Specification]	1	L	-	3	V	-	7	R	-	9	P	-	<table border="1"> <tr><td>Connector No.</td><td>C3</td></tr> <tr><td>Connector Name</td><td>REAR WHEEL SENSOR LH (2WD MODELS)</td></tr> <tr><td>Connector Type</td><td>RH02FGY</td></tr> </table>   <table border="1"> <tr><th>Terminal No.</th><th>Color of Wire</th><th>Signal Name [Specification]</th></tr> <tr><td>5</td><td>L</td><td>-</td></tr> <tr><td>6</td><td>R</td><td>-</td></tr> </table>	Connector No.	C3	Connector Name	REAR WHEEL SENSOR LH (2WD MODELS)	Connector Type	RH02FGY	Terminal No.	Color of Wire	Signal Name [Specification]	5	L	-	6	R	-	<table border="1"> <tr><td>Connector No.</td><td>C4</td></tr> <tr><td>Connector Name</td><td>REAR WHEEL SENSOR RH (2WD MODELS)</td></tr> <tr><td>Connector Type</td><td>RH02FGY</td></tr> </table>   <table border="1"> <tr><th>Terminal No.</th><th>Color of Wire</th><th>Signal Name [Specification]</th></tr> <tr><td>7</td><td>P</td><td>-</td></tr> <tr><td>8</td><td>V</td><td>-</td></tr> </table>	Connector No.	C4	Connector Name	REAR WHEEL SENSOR RH (2WD MODELS)	Connector Type	RH02FGY	Terminal No.	Color of Wire	Signal Name [Specification]	7	P	-	8	V	-	<table border="1"> <tr><td>Connector No.</td><td>C5</td></tr> <tr><td>Connector Name</td><td>REAR WHEEL SENSOR LH (4WD MODELS)</td></tr> <tr><td>Connector Type</td><td>RK02ML</td></tr> </table>   <table border="1"> <tr><th>Terminal No.</th><th>Color of Wire</th><th>Signal Name [Specification]</th></tr> <tr><td>5</td><td>L</td><td>-</td></tr> <tr><td>6</td><td>R</td><td>-</td></tr> </table>	Connector No.	C5	Connector Name	REAR WHEEL SENSOR LH (4WD MODELS)	Connector Type	RK02ML	Terminal No.	Color of Wire	Signal Name [Specification]	5	L	-	6	R	-																					
Connector No.	C2																																																																																									
Connector Name	WIRE TO WIRE																																																																																									
Connector Type	RH12MB																																																																																									
Terminal No.	Color of Wire	Signal Name [Specification]																																																																																								
1	L	-																																																																																								
3	V	-																																																																																								
7	R	-																																																																																								
9	P	-																																																																																								
Connector No.	C3																																																																																									
Connector Name	REAR WHEEL SENSOR LH (2WD MODELS)																																																																																									
Connector Type	RH02FGY																																																																																									
Terminal No.	Color of Wire	Signal Name [Specification]																																																																																								
5	L	-																																																																																								
6	R	-																																																																																								
Connector No.	C4																																																																																									
Connector Name	REAR WHEEL SENSOR RH (2WD MODELS)																																																																																									
Connector Type	RH02FGY																																																																																									
Terminal No.	Color of Wire	Signal Name [Specification]																																																																																								
7	P	-																																																																																								
8	V	-																																																																																								
Connector No.	C5																																																																																									
Connector Name	REAR WHEEL SENSOR LH (4WD MODELS)																																																																																									
Connector Type	RK02ML																																																																																									
Terminal No.	Color of Wire	Signal Name [Specification]																																																																																								
5	L	-																																																																																								
6	R	-																																																																																								

JCFWM0281Gf

A
B
C
D
E
BRC
G
H
I
J
K
L
M
N
O
P

ABS ACTUATOR AND ELECTRIC UNIT (CONTROL UNIT)

< ECU DIAGNOSIS >

[VDC/TCS/ABS]

BRAKE CONTROL SYSTEM (TYPE A)

Connector No.	C6
Connector Name	REAR WHEEL SENSOR RH (A/D MODELS)
Connector Type	RK02FGY



Terminal No.	Color of Wire	Signal Name [Specification]
7	P	-
8	V	-

Connector No.	E10
Connector Name	IPDM E/R (INTELLIGENT POWER DISTRIBUTION MODULE ENGINE ROOM)
Connector Type	TH20FW-CS12-M4-TV



Terminal No.	Color of Wire	Signal Name [Specification]
25	GR	-

Connector No.	E22
Connector Name	FRONT WHEEL SENSOR LH
Connector Type	RH02MB



Terminal No.	Color of Wire	Signal Name [Specification]
1	W	-
2	V	-

Connector No.	E27
Connector Name	PARKING BRAKE SWITCH
Connector Type	P01FB-A



Terminal No.	Color of Wire	Signal Name [Specification]
1	P	-

Connector No.	E36
Connector Name	ABS ACTUATOR AND ELECTRIC UNIT (CONTROL UNIT)
Connector Type	AEZ22FB-AJ24-LH

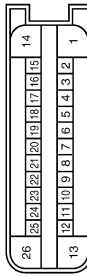

Terminal No.	Color of Wire	Signal Name [Specification]
1	R	VALVE/ECU SUPPLY
2	Y	WSS RL SIG(-)
3	L	WSS RL PWR(+)
4	GR	CLUSTER SUPPLY
5	B	WSS FR PWR(+)
6	W	WSS FR SIG(-)
7	LG	LIS
8	V	WSS FL SIG(-)
9	W	WSS FL PWR(+)
10	SB	CLUSTER GND
11	P	WSS RR PWR(+)

12	V	WSS RR SIG(-)
13	B/W	MOTOR GND
14	G	MOTOR SUPPLY
16	SB	BLS
18	O	DIAG K
19	BR	CAN2 H
20	GR	IGN
21	P	CAN1 L
22	Y	VDC OFF SW
23	L	CAN1 H
24	W	CAN2 L
26	B/W	VALVE/ECU GND

Connector No.	E37
Connector Name	BRAKE FLUID LEVEL SWITCH
Connector Type	YY02FGY



Terminal No.	Color of Wire	Signal Name [Specification]
1	P	-
2	B	-

Connector No.	E39
Connector Name	FRONT WHEEL SENSOR RH
Connector Type	RH02MB



Terminal No.	Color of Wire	Signal Name [Specification]
3	B	-
4	W	-

JCFWM0282GI

ABS ACTUATOR AND ELECTRIC UNIT (CONTROL UNIT)

< ECU DIAGNOSIS >

[VDC/TCS/ABS]

BRAKE CONTROL SYSTEM (TYPE A)

Connector No.	E103
Connector Name	FUSE BLOCK (J/B)
Connector Type	NS08FW-CS



Terminal No.	Color of Wire	Signal Name [Specification]
1F	L	-
2F	LG	-
3F	R	-

Connector No.	E104
Connector Name	WIRE TO WIRE
Connector Type	NS16FW-CS

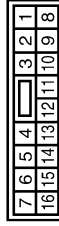

Terminal No.	Color of Wire	Signal Name [Specification]
13	P	-
14	V	-
15	Y	-
16	L	-

Connector No.	E105
Connector Name	WIRE TO WIRE
Connector Type	TH70MW-CS10-M3



Terminal No.	Color of Wire	Signal Name [Specification]
11	P	-
12	L	-
22	P	-
60	V	-
82	O	-
85	W	-
87	BR	-
88	Y	-
89	SB	-
70	GR	-

Connector No.	E115
Connector Name	STOP LAMP SWITCH (TYPE A)
Connector Type	M04FW-LC



Terminal No.	Color of Wire	Signal Name [Specification]
3	R	-
4	LG	-

Connector No.	M1
Connector Name	FUSE BLOCK (J/B)
Connector Type	NS08FW-M2



Terminal No.	Color of Wire	Signal Name [Specification]
2A	G	-

Connector No.	M4
Connector Name	DATA LINK CONNECTOR
Connector Type	BD16FW

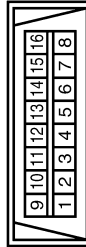

Terminal No.	Color of Wire	Signal Name [Specification]
7	O	-

Connector No.	M5
Connector Name	VDC OFF SWITCH
Connector Type	TK08FGY



Terminal No.	Color of Wire	Signal Name [Specification]
1	W	-
2	B	-

Connector No.	M11
Connector Name	WIRE TO WIRE
Connector Type	TH70FW-CS10-M3

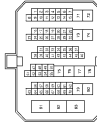

Terminal No.	Color of Wire	Signal Name [Specification]
11	P	-
12	L	-
22	G	-
80	V	-
82	O	-
66	W	-
67	R	-
68	W	-
69	P	-
70	G	-

JCFWM0283GF

A
B
C
D
E
BRC
G
H
I
J
K
L
M
N
O
P

ABS ACTUATOR AND ELECTRIC UNIT (CONTROL UNIT)

< ECU DIAGNOSIS >

[VDC/TCS/ABS]

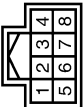
BRAKE CONTROL SYSTEM (TYPE A)		
Connector No.	M30	
Connector Name	STEERING ANGLE SENSOR	
Connector Type	TH08FW-NH	
Terminal No.	Color of Wire	Signal Name [Specification]
1	B	-
2	P	-
4	G	-
5	L	-

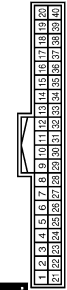
Connector No.	M34	
Connector Name	COMBINATION METER	
Connector Type	TH10FW-NH	
Terminal No.	Color of Wire	Signal Name [Specification]
21	L	CAN-H
22	P	CAN-L
26	G	PARKING BRAKE SWITCH
27	V	BRAKE FLUID LEVEL SWITCH

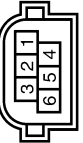
Connector No.	M52	
Connector Name	YAW RATE / SIDE / DECEL G SENSOR	
Connector Type	AZ08FBZ-Z	
Terminal No.	Color of Wire	Signal Name [Specification]
1	W	-
2	R	-
3	G	-
5	P	-

JCFWM0284GI

FROM VIN: JN8AZ18U*9W10001, JN8AZ18W*9W20001 (EXCEPT FOR MEXICO),
 JN8AZ18U*9W710001, JN8AZ18W*9W810001 (FOR MEXICO)

ABS ACTUATOR AND ELECTRIC UNIT (CONTROL UNIT)

< ECU DIAGNOSIS >

[VDC/TCS/ABS]

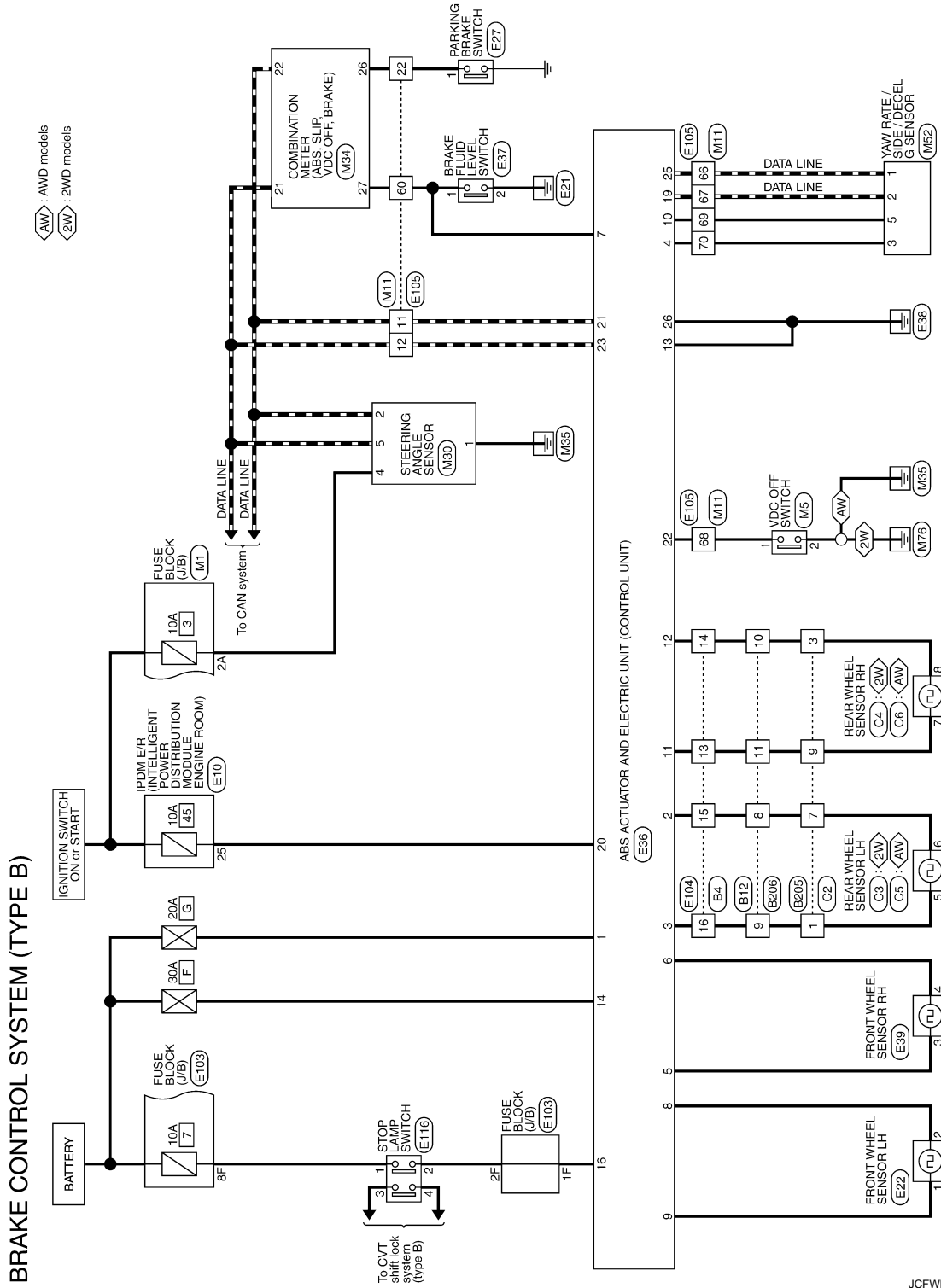

2008/09/23

JCFWM0285Gf

A
B
C
D
E
F
G
H
I
J
K
L
M
N
O
P

BRC

ABS ACTUATOR AND ELECTRIC UNIT (CONTROL UNIT)

< ECU DIAGNOSIS >

[VDC/TCS/ABS]

BRAKE CONTROL SYSTEM (TYPE B)

Connector No.	B4
Connector Name	WIRE TO WIRE
Connector Type	NS16MW-GS



Terminal No.	Color of Wire	Signal Name [Specification]
13	P	-
14	BR	-
15	O	-
16	G	-

Connector No.	B12
Connector Name	WIRE TO WIRE
Connector Type	NS16FW-GS



Terminal No.	Color of Wire	Signal Name [Specification]
8	O	-
9	G	-
10	BR	-
11	P	-

Connector No.	B205
Connector Name	WIRE TO WIRE
Connector Type	RH12FB

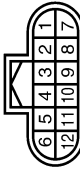

Terminal No.	Color of Wire	Signal Name [Specification]
1	W	-
3	V	-
7	B	-
9	P	-

Connector No.	B206
Connector Name	WIRE TO WIRE
Connector Type	NS16MW-GS



Terminal No.	Color of Wire	Signal Name [Specification]
8	B	-
9	W	-
10	V	-
11	P	-

Connector No.	C2
Connector Name	WIRE TO WIRE
Connector Type	RH12MB

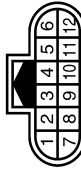

Terminal No.	Color of Wire	Signal Name [Specification]
1	L	-
3	V	-
7	R	-
9	P	-

Connector No.	C3
Connector Name	REAR WHEEL SENSOR LH (2WD MODELS)
Connector Type	RH02FGY



Terminal No.	Color of Wire	Signal Name [Specification]
5	L	-
6	R	-

Connector No.	C4
Connector Name	REAR WHEEL SENSOR RH (2WD MODELS)
Connector Type	RH02FGY



Terminal No.	Color of Wire	Signal Name [Specification]
7	P	-
8	V	-

Connector No.	C5
Connector Name	REAR WHEEL SENSOR LH (4WD MODELS)
Connector Type	RK02ML



Terminal No.	Color of Wire	Signal Name [Specification]
5	L	-
6	R	-

JCFWM0286GI

ABS ACTUATOR AND ELECTRIC UNIT (CONTROL UNIT)

< ECU DIAGNOSIS >

[VDC/TCS/ABS]

BRAKE CONTROL SYSTEM (TYPE B)

Connector No.	G6
Connector Name	REAR WHEEL SENSOR RH (AWD MODELS)
Connector Type	RK02FGY



Terminal No.	Color of Wire	Signal Name [Specification]
7	P	-
8	V	-

Connector No.	E10
Connector Name	EDM E/R INTELLIGENT POWER DISTRIBUTION MODULE (ENGINE ROOM)
Connector Type	TH20FW-C51Z-IM-TV



Terminal No.	Color of Wire	Signal Name [Specification]
25	GR	-

Connector No.	E22
Connector Name	FRONT WHEEL SENSOR LH
Connector Type	RH02MB



Terminal No.	Color of Wire	Signal Name [Specification]
1	W	-
2	V	-

Connector No.	E27
Connector Name	PARKING BRAKE SWITCH
Connector Type	P01FB-A



Terminal No.	Color of Wire	Signal Name [Specification]
1	P	-

Connector No.	E36
Connector Name	ABS ACTUATOR AND ELECTRIC UNIT (CONTROL UNIT)
Connector Type	AEZ22FB-AJ24-LH

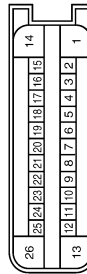

Terminal No.	Color of Wire	Signal Name [Specification]
1	R	VALVE/ECU SUPPLY
2	Y	WSS RL SIG(-)
3	L	WSS RL PWM(+)
4	GR	CLUSTER SUPPLY
5	B	WSS FR PWM(+)
6	W	WSS FR SIG(-)
7	LG	LIS
8	V	WSS FL SIG(-)
9	W	WSS FL PWM(+)
10	SB	CLUSTER GND
11	P	WSS RR PWM(+)

12	V	WSS RR SIG(-)
13	B/W	MOTOR GND
14	G	MOTOR SUPPLY
16	SB	BLS
19	BR	CAN2 H
20	GR	IGN
21	P	CAN1 L
22	Y	VDC OFF SW
23	L	CAN1 H
25	W	CAN2 L
26	B/W	VALVE/ECU GND

Connector No.	E37
Connector Name	BRAKE FLUID LEVEL SWITCH
Connector Type	YV02FGY



Terminal No.	Color of Wire	Signal Name [Specification]
1	P	-
2	B	-

Connector No.	E39
Connector Name	FRONT WHEEL SENSOR RH
Connector Type	RH02MB



Terminal No.	Color of Wire	Signal Name [Specification]
3	B	-
4	W	-

A
B
C
D
E
BRC
G
H
I
J
K
L
M
N
O
P

ABS ACTUATOR AND ELECTRIC UNIT (CONTROL UNIT)

< ECU DIAGNOSIS >

[VDC/TCS/ABS]

BRAKE CONTROL SYSTEM (TYPE B)

Connector No.	E103
Connector Name	FUSE BLOCK (J/B)
Connector Type	NS18FW-GS



Terminal No.	Color of Wire	Signal Name [Specification]
1F	L	-
2F	LG	-
8F	R	-

Connector No.	E104
Connector Name	WIRE TO WIRE
Connector Type	NS18FW-GS

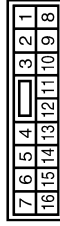

Terminal No.	Color of Wire	Signal Name [Specification]
13	P	-
14	V	-
15	Y	-
16	L	-

Connector No.	E105
Connector Name	WIRE TO WIRE
Connector Type	TH70MW-GS10-M3



Terminal No.	Color of Wire	Signal Name [Specification]
11	P	-
12	L	-
22	P	-
60	V	-
66	W	-
67	BR	-
68	Y	-
69	SB	-
70	GR	-

Connector No.	E116
Connector Name	STOP LAMP SWITCH (TYPE B)
Connector Type	M04FW-LC



Terminal No.	Color of Wire	Signal Name [Specification]
1	R	-
2	LG	-
3	G	-
4	Y	-

Connector No.	M1
Connector Name	FUSE BLOCK (J/B)
Connector Type	NS08FW-M2



Terminal No.	Color of Wire	Signal Name [Specification]
2A	G	-

Connector No.	M5
Connector Name	VDC OFF SWITCH
Connector Type	TK08FGY



Terminal No.	Color of Wire	Signal Name [Specification]
1	W	-
2	B	-

Connector No.	M11
Connector Name	WIRE TO WIRE
Connector Type	TH70FW-GS10-M3



Terminal No.	Color of Wire	Signal Name [Specification]
11	P	-
12	L	-
22	G	-
60	V	-
66	W	-
67	R	-
68	W	-
69	P	-
70	G	-

Connector No.	M30
Connector Name	STEERING ANGLE SENSOR
Connector Type	TH08FW-AH

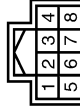

Terminal No.	Color of Wire	Signal Name [Specification]
1	B	-
2	P	-
4	G	-
5	L	-

JCFWM0288G1

ABS ACTUATOR AND ELECTRIC UNIT (CONTROL UNIT)

< ECU DIAGNOSIS >

[VDC/TCS/ABS]

A
B
C
D
E
G
H
I
J
K
L
M
N
O
P

BRC

BRAKE CONTROL SYSTEM (TYPE B)

Connector No.	M34
Connector Name	COMBINATION METER
Connector Type	TH40FY-NH

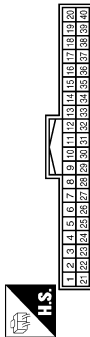

Terminal No.	Color of Wire	Signal Name [Specification]
21	L	CAN-H
22	P	CAN-L
26	G	PARKING BRAKE SWITCH
27	V	BRAKE FLUID LEVEL SWITCH

Connector No.	M52
Connector Name	YAW RATE / SIDE / DECEL G SENSOR
Connector Type	AAZ06F52-Z



Terminal No.	Color of Wire	Signal Name [Specification]
1	W	-
2	R	-
3	G	-
5	P	-

Fail-Safe

ABS, EBD SYSTEM

If ABS malfunction electrically, ABS warning lamp, VDC OFF indicator lamp, SLIP indicator lamp will turn on. If EBD malfunction electrically, brake warning lamp, ABS warning lamp, VDC OFF indicator lamp and SLIP indicator lamp will turn on. Simultaneously, the VDC/TCS/ABS become one of the following conditions of the fail-safe function.

JCFWM0289Gf

INFOID:000000003247242

ABS ACTUATOR AND ELECTRIC UNIT (CONTROL UNIT)

[VDC/TCS/ABS]

< ECU DIAGNOSIS >

- For malfunction of ABS, only the EBD is activated and the condition of vehicle is the same condition of vehicles without TCS/ABS system.

NOTE:

ABS self-diagnosis sound may be heard. That is a normal condition because a self-diagnosis for "Ignition switch ON" and "The first starting" are being performed.

- For malfunction of EBD, EBD and ABS become inoperative, and the condition of vehicle is the same as the condition of vehicles without TCS/ABS, EBD system.

VDC/TCS

If VDC/TCS/ABS system malfunction electrically, VDC OFF indicator lamp, SLIP indicator lamp are turned on, and the condition of vehicle is the same as the condition of vehicles without VDC/TCS control.

CAUTION:

If the Fail-Safe function is activated, then perform self-diagnosis for VDC/TCS/ABS control system.

DTC No. Index

INFOID:000000003247243

DTC	Items (CONSULT screen terms)	Reference
C1101	RR RH SENSOR-1	BRC-34, "DTC Logic"
C1102	RR LH SENSOR-1	
C1103	FR RH SENSOR-1	
C1104	FR LH SENSOR-1	
C1105	RR RH SENSOR-2	BRC-38, "DTC Logic"
C1106	RR LH SENSOR-2	
C1107	FR RH SENSOR-2	
C1108	FR LH SENSOR-2	
C1109	BATTERY VOLTAGE [ABNORMAL]	BRC-41, "DTC Logic"
C1110	CONTROLLER FAILURE	BRC-43, "DTC Logic"
C1111	PUMP MOTOR	BRC-44, "DTC Logic"
C1113	G SENSOR	BRC-46, "DTC Logic"
C1115	ABS SENSOR [ABNORMAL SIGNAL]	BRC-49, "DTC Logic"
C1116	STOP LAMP SW	BRC-52, "DTC Logic"
C1120	FR LH IN ABS SOL	BRC-54, "DTC Logic"
C1121	FR LH OUT ABS SOL	BRC-57, "DTC Logic"
C1122	FR RH IN ABS SOL	BRC-54, "DTC Logic"
C1123	FR RH OUT ABS SOL	BRC-57, "DTC Logic"
C1124	RR LH IN ABS SOL	BRC-54, "DTC Logic"
C1125	RR LH OUT ABS SOL	BRC-57, "DTC Logic"
C1126	RR RH IN ABS SOL	BRC-54, "DTC Logic"
C1127	RR RH OUT ABS SOL	BRC-57, "DTC Logic"
C1130	ENGINE SIGNAL 1	BRC-60, "DTC Logic"
C1140	ACTUATOR RLY	BRC-62, "DTC Logic"
C1142	PRESS SEN CIRCUIT	BRC-64, "DTC Logic"
C1143	ST ANG SEN CIRCUIT	BRC-66, "DTC Logic"
C1144	ST ANG SEN SIGNAL	BRC-68, "DTC Logic"
C1145	YAW RATE SENSOR	BRC-46, "DTC Logic"
C1146	SIDE G-SEN CIRCUIT	
C1155	BR FLUID LEVEL LOW	BRC-69, "DTC Logic"
C1160	DECEL G SEN SET	BRC-71, "DTC Logic"
C1161	SIDE G SEN SET	

ABS ACTUATOR AND ELECTRIC UNIT (CONTROL UNIT)

< ECU DIAGNOSIS >

[VDC/TCS/ABS]

DTC	Items (CONSULT screen terms)	Reference
C1162	PRESS SEN SET	BRC-72, "DTC Logic"
C1164	CV1	BRC-73, "DTC Logic"
C1165	CV2	
C1166	SV1	BRC-75, "DTC Logic"
C1167	SV2	
C1170	VARIANT CODING	BRC-43, "DTC Logic"
U1000	CAN COMM CIRCUIT	BRC-77, "DTC Logic"
U1002	SYSTEM COMM (CAN)	

A
B
C
D
E
G
H
I
J
K
L
M
N
O
P

BRC

SYMPTOM DIAGNOSIS

EXCESSIVE ABS FUNCTION OPERATION FREQUENCY

Diagnosis Procedure

INFOID:000000003247244

1. CHECK START

Check front and rear brake force distribution using a brake tester. Refer to [BR-47. "General Specifications"](#).

Is the inspection result normal?

YES >> GO TO 2.

NO >> Check brake system.

2. CHECK FRONT AND REAR AXLE

Make sure that there is no excessive play in the front and rear axles.

• Front

- 2WD models: Refer to [FAX-8. "Inspection"](#).

- AWD models: Refer to [FAX-35. "Inspection"](#).

• Rear

- 2WD models: Refer to [RAX-4. "Inspection"](#).

- AWD models: Refer to [RAX-11. "Inspection"](#).

Is the inspection result normal?

YES >> GO TO 3.

NO >> Repair or replace damaged parts.

3. CHECK WHEEL SENSOR AND SENSOR ROTOR

Check the following.

• Wheel sensor installation for damage.

• Sensor rotor installation for damage.

• Wheel sensor connector connection.

• Wheel sensor harness inspection.

Is the inspection result normal?

YES >> GO TO 4.

NO >> • Replace wheel sensor or sensor rotor.
• Repair harness.

4. CHECK ABS WARNING LAMP DISPLAY

Make sure that the ABS warning lamp is turned off after the ignition switch is turned ON or when driving.

Is the ABS warning lamp illuminated?

YES >> Perform self-diagnosis.

NO >> Normal

UNEXPECTED PEDAL REACTION

< SYMPTOM DIAGNOSIS >

[VDC/TCS/ABS]

UNEXPECTED PEDAL REACTION

Diagnosis Procedure

INFOID:000000003247245

1.CHECK BRAKE PEDAL STROKE

Check brake pedal stroke. Refer to [BR-9, "Inspection and Adjustment"](#).

Is the stroke too large?

- YES >>
- Bleed air from brake tube and hose. Refer to [BR-13, "Bleeding Brake System"](#).
 - Check brake pedal, brake booster, and master cylinder for mount play, looseness, brake system fluid leakage, etc.
 - Brake pedal: Refer to [BR-9, "Inspection and Adjustment"](#).
 - Brake master cylinder: Refer to [BR-14, "Inspection"](#).
 - Brake booster: Refer to [BR-15, "Inspection"](#).

NO >> GO TO 2.

2.CHECK FUNCTION

Disconnect ABS actuator and electric unit (control unit) connector to deactivate ABS. Check if braking force is normal in this condition. Connect connector after inspection.

Is the inspection result normal?

- YES >> Normal
NO >> Check brake system.

A
B
C
D
E
BRC
G
H
I
J
K
L
M
N
O
P

THE BRAKING DISTANCE IS LONG

< SYMPTOM DIAGNOSIS >

[VDC/TCS/ABS]

THE BRAKING DISTANCE IS LONG

Diagnosis Procedure

INFOID:000000003247246

CAUTION:

The stopping distance on slippery road surfaces might be longer with the ABS operating than when the ABS is not operating.

1.CHECK FUNCTION

Turn the ignition switch OFF and disconnect ABS actuator and electric unit (control unit) connector to deactivate ABS. In this condition, check stopping distance. After inspection, connect connector.

Is the inspection result normal?

YES >> Normal

NO >> Check brake system.

ABS FUNCTION DOES NOT OPERATE

< SYMPTOM DIAGNOSIS >

[VDC/TCS/ABS]

ABS FUNCTION DOES NOT OPERATE

Diagnosis Procedure

INFOID:000000003247247

CAUTION:

ABS does not operate when speed is 10 km/h (6 MPH) or lower.

1.CHECK ABS WARNING LAMP DISPLAY

Make sure that the ABS warning lamp turns OFF after ignition switch is turned ON or when driving.

Is the inspection result normal?

YES >> Normal

NO >> Perform self-diagnosis.

A
B
C
D
E
G
H
I
J
K
L
M
N
O
P

BRC

PEDAL VIBRATION OR ABS OPERATION SOUND OCCURS

< SYMPTOM DIAGNOSIS >

[VDC/TCS/ABS]

PEDAL VIBRATION OR ABS OPERATION SOUND OCCURS

Diagnosis Procedure

INFOID:000000003247248

CAUTION:

Under the following conditions, ABS is activated and vibration is felt when brake pedal is lightly depressed (just place a foot on it). However, this is normal.

- When shifting gears
- When driving on slippery road
- During cornering at high speed
- When passing over bumps or grooves [at approximately 50 mm (1.97 in) or more]
- When pulling away just after starting engine [at approximately 10 km/h (6 MPH) or higher]

1. SYMPTOM CHECK 1

Check that there are pedal vibrations when the engine is started.

Do vibrations occur?

YES >> GO TO 2.

NO >> Inspect the brake pedal.

2. SYMPTOM CHECK 2

Check that there are ABS operation noises when the engine is started.

Do the operation noises occur?

YES >> GO TO 3.

NO >> Perform self-diagnosis.

3. SYMPTOM CHECK 3

Check symptoms when electrical component (headlamps, etc.) switches are operated.

Do symptoms occur?

YES >> Check if there is a radio, antenna, antenna lead wire, or wiring close to the control unit. If there is, move it farther away.

NO >> Normal

VEHICLE JERKS DURING VDC/TCS/ABS CONTROL

< SYMPTOM DIAGNOSIS >

[VDC/TCS/ABS]

VEHICLE JERKS DURING VDC/TCS/ABS CONTROL

Diagnosis Procedure

INFOID:000000003247249

1.SYMPTOM CHECK

Check if the vehicle jerks during VDC/TCS/ABS control.

Is the inspection result normal?

- YES >> Normal.
- NO >> GO TO 2.

2.CHECK SELF-DIAGNOSIS RESULTS

Perform self-diagnostic of ABS actuator and electric unit (control unit).

Are self-diagnosis results indicated?

- YES >> Check corresponding items, make repairs, and perform ABS actuator and electric unit (control unit) self-diagnosis.
- NO >> GO TO 3.

3.CHECK CONNECTOR

- Turn the ignition switch OFF and disconnect ABS actuator and electric unit (control unit) connector and check terminal for deformation, disconnection, looseness, etc.
- Securely connect connectors and perform ABS actuator and electric unit (control unit) self-diagnosis.

Are self-diagnosis results indicated?

- YES >> If poor contact, damage, open or short circuit of connector terminal is found, repair or replace.
- NO >> GO TO 4.

4.CHECK ECM AND TCM SELF-DIAGNOSIS RESULTS

Perform ECM self-diagnosis and TCM self-diagnosis.

Are self-diagnosis results indicated?

- YES >> Check the corresponding items.
 - ECM: Refer to [EC-102. "Diagnosis Description"](#).
 - TCM: Refer to [TM-32. "Diagnosis Description"](#).
- NO >> Replace ABS actuator and electric unit (control unit).

A
B
C
D
E
G
H
I
J
K
L
M
N
O
P

BRC

NORMAL OPERATING CONDITION

< SYMPTOM DIAGNOSIS >

[VDC/TCS/ABS]

NORMAL OPERATING CONDITION

Description

INFOID:000000003247250

Symptom	Result
Slight vibrations are felt on the brake pedal and the operation noises occur, when VDC, TCS or ABS is activated.	This is a normal condition due to the VDC, TCS or ABS activation.
Stopping distance is longer than that of vehicles without ABS when the vehicle drives on rough, gravel, or snow-covered (fresh, deep snow) roads.	
The brake pedal moves and generates noises, when TCS or VDC is activated due to rapid acceleration or sharp turn.	
The brake pedal vibrates and motor operation noises occur from the engine room, after the engine starts and just after the vehicle starts.	This is a normal, and it is caused by the ABS operation check.
Depending on the road conditions, the driver may experience a sluggish feel.	This is normal, because TCS places the highest priority on the optimum traction (stability).
TCS may activate momentarily if wheel speed changes when driving over location where friction coefficient varies, when downshifting, or when fully depressing accelerator pedal.	
The ABS warning lamp, VDC OFF indicator lamp and SLIP indicator lamp may turn ON when the vehicle is subject to strong shaking or large vibration, such as when the vehicle is rotating on a turntable or located on a ship while the engine is running.	In this case, restart the engine on a normal road. If the normal condition is restored, there is no malfunction. At that time, erase the self-diagnosis memory.
VDC may not operate normally or the ABS warning lamp, VDC OFF indicator lamp, and SLIP indicator lamp may illuminate, when running on a special road that is extremely slanted (e.g. bank in a circuit course).	
A malfunction may occur in the yaw rate/side G sensor system, when the vehicle turns sharply, such as during a spin turn, axle turn, or drift driving, while the VDC function is off (VDC OFF indicator lamp illuminated).	
The vehicle speed will not increase even though the accelerator pedal is depressed, when inspecting the speedometer on a 2-wheel chassis dynamometer.	Normal (Deactivate the VDC/TCS function before performing an inspection on a chassis dynamometer.)

PRECAUTION

PRECAUTIONS
FOR USA AND CANADA

FOR USA AND CANADA : Precaution for Supplemental Restraint System (SRS) "AIR BAG" and "SEAT BELT PRE-TENSIONER"

INFOID:000000004790234

The Supplemental Restraint System such as "AIR BAG" and "SEAT BELT PRE-TENSIONER", used along with a front seat belt, helps to reduce the risk or severity of injury to the driver and front passenger for certain types of collision. This system includes seat belt switch inputs and dual stage front air bag modules. The SRS system uses the seat belt switches to determine the front air bag deployment, and may only deploy one front air bag, depending on the severity of a collision and whether the front occupants are belted or unbelted. Information necessary to service the system safely is included in the "SRS AIRBAG" and "SEAT BELT" of this Service Manual.

WARNING:

- To avoid rendering the SRS inoperative, which could increase the risk of personal injury or death in the event of a collision which would result in air bag inflation, all maintenance must be performed by an authorized NISSAN/INFINITI dealer.
- Improper maintenance, including incorrect removal and installation of the SRS, can lead to personal injury caused by unintentional activation of the system. For removal of Spiral Cable and Air Bag Module, see the "SRS AIRBAG".
- Never use electrical test equipment on any circuit related to the SRS unless instructed to in this Service Manual. SRS wiring harnesses can be identified by yellow and/or orange harnesses or harness connectors.

BRC

PRECAUTIONS WHEN USING POWER TOOLS (AIR OR ELECTRIC) AND HAMMERS

When working near the Airbag Diagnosis Sensor Unit or other Airbag System sensors while ignition switch is ON or engine is running, never use air or electric power tools or strike near the sensor(s) with a hammer. Heavy vibration may activate the sensor(s), deploy the airbag(s), possibly cause serious injury. When using air or electric power tools or hammers, always turn OFF ignition switch, disconnect the battery, and wait 3 minutes or more before performing any service.

FOR USA AND CANADA : Precaution for Procedure without Cowl Top Cover

INFOID:000000004790235

When performing the procedure after removing cowl top cover, cover the lower end of windshield with urethane, etc.

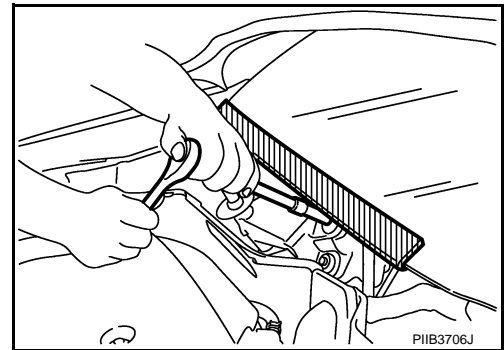

FOR USA AND CANADA : Precaution for Brake System

INFOID:000000003247253

WARNING:

Clean any dust from the front brake and rear brake with a vacuum dust collector. Never blow with compressed air.

CAUTION:

- Only use "DOT 3" brake fluid. Refer to [MA-15, "FOR NORTH AMERICA : Fluids and Lubricants"](#).
- Never reuse drained brake fluid.
- Never spill or splash brake fluid on painted surfaces. Brake fluid may seriously damage paint. Wipe it off immediately and wash with water if it gets on a painted surface.
- Never use mineral oils such as gasoline or light oil to clean. They may damage rubber parts and cause improper operation.
- Always loosen the brake tube flare nut with a flare nut wrench.

A
B
C
D
E
G
H
I
J
K
L
M
N
O
P

PRECAUTIONS

[VDC/TCS/ABS]

< PRECAUTION >

- Tighten the brake tube flare nut to the specified torque with crowfoot (A) and torque wrench (B).
- Always confirm the specified tightening torque when installing the brake pipes.
- Turn the ignition switch OFF and disconnect the ABS actuator and electric unit (control unit) connector or the battery negative terminal before performing the work.
- Check that no brake fluid leakage is present after replacing the parts.

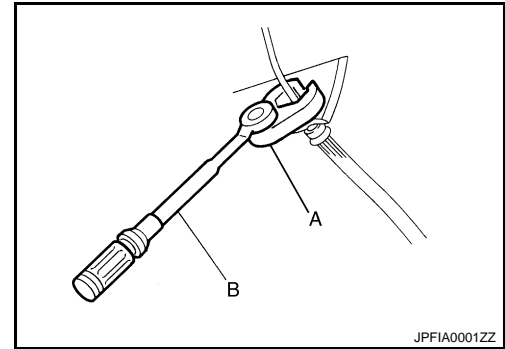

FOR USA AND CANADA : Precaution for Brake Control

INFOID:000000003247254

- When starting engine or when starting vehicle just after starting engine, brake pedal may vibrate or motor operating noise may be heard from engine compartment. This is normal condition.
- When an error is indicated by ABS or another warning lamp, collect all necessary information from customer (what symptoms are present under what conditions) and check for estimate causes before starting diagnostic servicing. Besides electrical system inspection, check brake booster operation, brake fluid level, and oil leaks.
- If tire size and type are used in an improper combination, or brake pads are not Genuine NISSAN parts, stopping distance or steering stability may deteriorate.
- ABS might be out of order or malfunctions by putting a radio (wiring inclusive), an antenna and a lead-in wire near the control unit.
- If aftermarket parts (car stereo, CD player, etc.) have been installed, check for incidents such as harness pinches, open circuits, and improper wiring.
- VDC system may not operate normally or a VDC OFF indicator lamp or SLIP indicator lamp may light.
- When replacing the following parts with parts other than genuine parts or making modifications: Suspension-related parts (shock absorber, spring, bushing, etc.), tires, wheels (other than specified sizes), brake-related parts (pad, rotor, caliper, etc.), engine-related parts (muffler, ECM, etc.) and body reinforcement-related parts (roll bar, tower bar, etc.).
- When driving with worn or deteriorated suspension, tires and brake-related parts.

FOR MEXICO

FOR MEXICO : Precaution for Supplemental Restraint System (SRS) "AIR BAG" and "SEAT BELT PRE-TENSIONER"

INFOID:000000004790236

The Supplemental Restraint System such as "AIR BAG" and "SEAT BELT PRE-TENSIONER", used along with a front seat belt, helps to reduce the risk or severity of injury to the driver and front passenger for certain types of collision. This system includes seat belt switch inputs and dual stage front air bag modules. The SRS system uses the seat belt switches to determine the front air bag deployment, and may only deploy one front air bag, depending on the severity of a collision and whether the front occupants are belted or unbelted.

Information necessary to service the system safely is included in the "SRS AIRBAG" and "SEAT BELT" of this Service Manual.

WARNING:

- To avoid rendering the SRS inoperative, which could increase the risk of personal injury or death in the event of a collision which would result in air bag inflation, all maintenance must be performed by an authorized NISSAN/INFINITI dealer.
- Improper maintenance, including incorrect removal and installation of the SRS, can lead to personal injury caused by unintentional activation of the system. For removal of Spiral Cable and Air Bag Module, see the "SRS AIRBAG".
- Never use electrical test equipment on any circuit related to the SRS unless instructed to in this Service Manual. SRS wiring harnesses can be identified by yellow and/or orange harnesses or harness connectors.

PRECAUTIONS WHEN USING POWER TOOLS (AIR OR ELECTRIC) AND HAMMERS

When working near the Airbag Diagnosis Sensor Unit or other Airbag System sensors while ignition switch is ON or engine is running, never use air or electric power tools or strike near the sensor(s) with a hammer. Heavy vibration may activate the sensor(s), deploy the airbag(s), possibly cause serious injury.

When using air or electric power tools or hammers, always turn OFF ignition switch, disconnect the battery, and wait 3 minutes or more before performing any service.

PRECAUTIONS

< PRECAUTION >

[VDC/TCS/ABS]

FOR MEXICO : Precaution for Procedure without Cowl Top Cover

INFOID:000000004790237

When performing the procedure after removing cowl top cover, cover the lower end of windshield with urethane, etc.

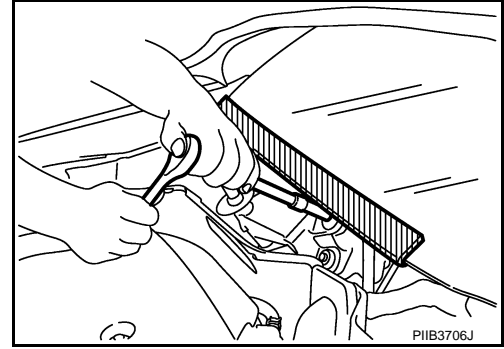

FOR MEXICO : Precaution for Brake System

INFOID:000000004790238

WARNING:

Clean any dust from the front brake and rear brake with a vacuum dust collector. Never blow with compressed air.

CAUTION:

- Only use "DOT 3" brake fluid. Refer to [MA-16, "FOR MEXICO : Fluids and Lubricants"](#).
- Never reuse drained brake fluid.
- Never spill or splash brake fluid on painted surfaces. Brake fluid may seriously damage paint. Wipe it off immediately and wash with water if it gets on a painted surface.
- Never use mineral oils such as gasoline or light oil to clean. They may damage rubber parts and cause improper operation.
- Always loosen the brake tube flare nut with a flare nut wrench.
- Tighten the brake tube flare nut to the specified torque with crowfoot (A) and torque wrench (B).
- Always confirm the specified tightening torque when installing the brake pipes.
- Turn the ignition switch OFF and disconnect the ABS actuator and electric unit (control unit) connector or the battery negative terminal before performing the work.
- Check that no brake fluid leakage is present after replacing the parts.

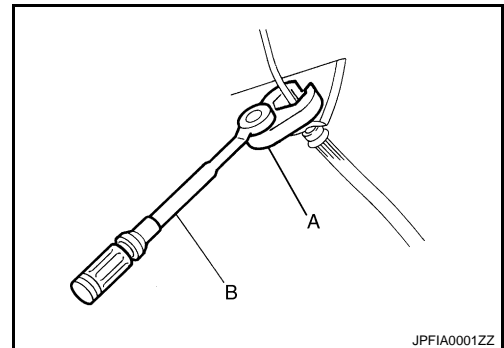

FOR MEXICO : Precaution for Brake Control

INFOID:000000004790239

- When starting engine or when starting vehicle just after starting engine, brake pedal may vibrate or motor operating noise may be heard from engine compartment. This is normal condition.
- When an error is indicated by ABS or another warning lamp, collect all necessary information from customer (what symptoms are present under what conditions) and check for estimate causes before starting diagnostic servicing. Besides electrical system inspection, check brake booster operation, brake fluid level, and oil leaks.
- If tire size and type are used in an improper combination, or brake pads are not Genuine NISSAN parts, stopping distance or steering stability may deteriorate.
- ABS might be out of order or malfunctions by putting a radio (wiring inclusive), an antenna and a lead-in wire near the control unit.
- If aftermarket parts (car stereo, CD player, etc.) have been installed, check for incidents such as harness pinches, open circuits, and improper wiring.
- VDC system may not operate normally or a VDC OFF indicator lamp or SLIP indicator lamp may light.
- When replacing the following parts with parts other than genuine parts or making modifications: Suspension-related parts (shock absorber, spring, bushing, etc.), tires, wheels (other than specified sizes), brake-related parts (pad, rotor, caliper, etc.), engine-related parts (muffler, ECM, etc.) and body reinforcement-related parts (roll bar, tower bar, etc.).
- When driving with worn or deteriorated suspension, tires and brake-related parts.

A
B
C
D
E
G
H
I
J
K
L
M
N
O
P

BRC

ON-VEHICLE REPAIR

WHEEL SENSOR

FRONT WHEEL SENSOR

FRONT WHEEL SENSOR : Exploded View

INFOID:000000003247255

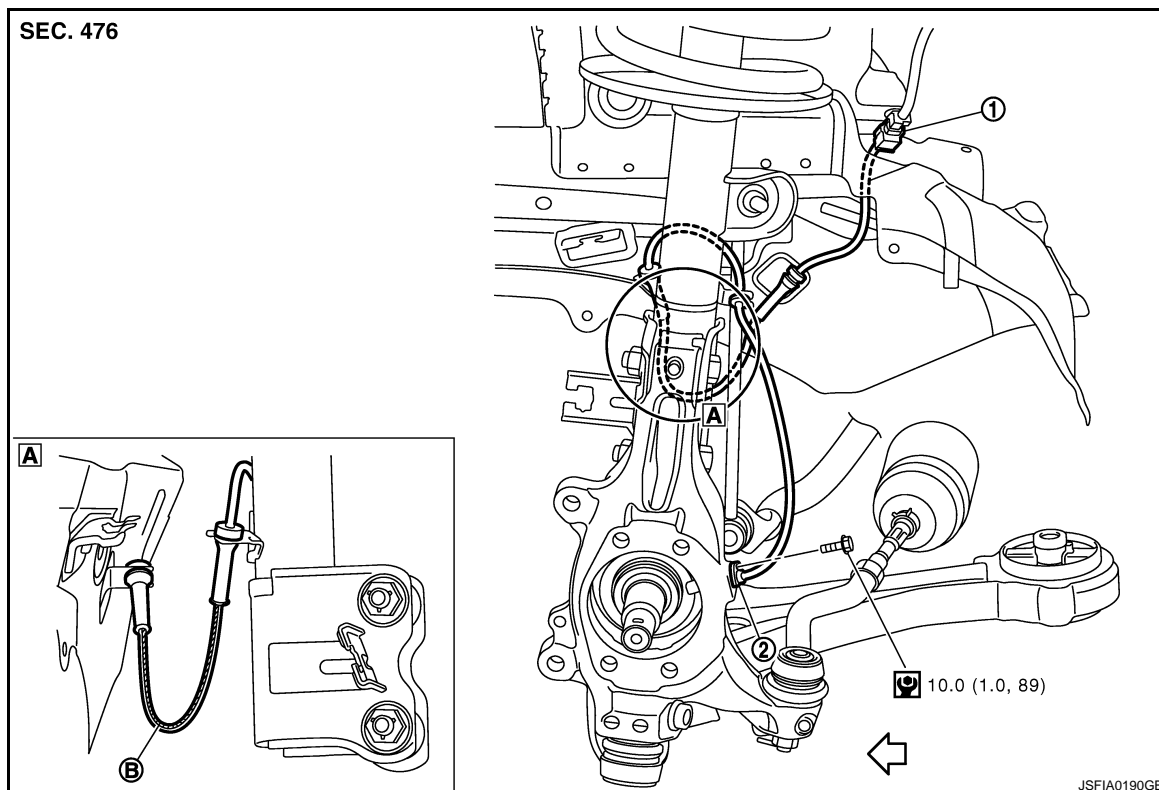

1. Front LH wheel sensor connector 2. Front LH wheel sensor

B. White line (slant line)

← : Vehicle front

Refer to [GI-4, "Components"](#) for symbol in the figure.

NOTE:

The above figure (front side) shows left side. Right side is the mirror image.

FRONT WHEEL SENSOR : Removal and Installation

INFOID:000000003247256

REMOVAL

Be careful with the following when removing sensor.

CAUTION:

- Do not twist sensor harness as much as possible, when removing it. Pull sensors out without pulling sensor harness.
- Be careful to avoid damaging sensor edges or rotor teeth. Remove wheel sensor first before removing front or rear wheel hub. This is to avoid damage to sensor wiring and loss of sensor function.
- When you see the harness of the wheel sensor from the front side of the vehicle ensure that the white lines (B) are not twisted.

INSTALLATION

Be careful with the following when installing wheel sensor. Tighten installation bolts to the specified torques.

- When installing, make sure there is no foreign material such as iron chips on and in the mounting hole of the wheel sensor. Make sure no foreign material has been caught in the sensor rotor. Remove any foreign material and clean the mount.

WHEEL SENSOR

< ON-VEHICLE REPAIR >

[VDC/TCS/ABS]

- When installing wheel sensor, be sure to press rubber grommets in until they lock at locations shown above in the figure. When installed, harness must not be twisted.

REAR WHEEL SENSOR

REAR WHEEL SENSOR : Exploded View

INFOID:000000003247257

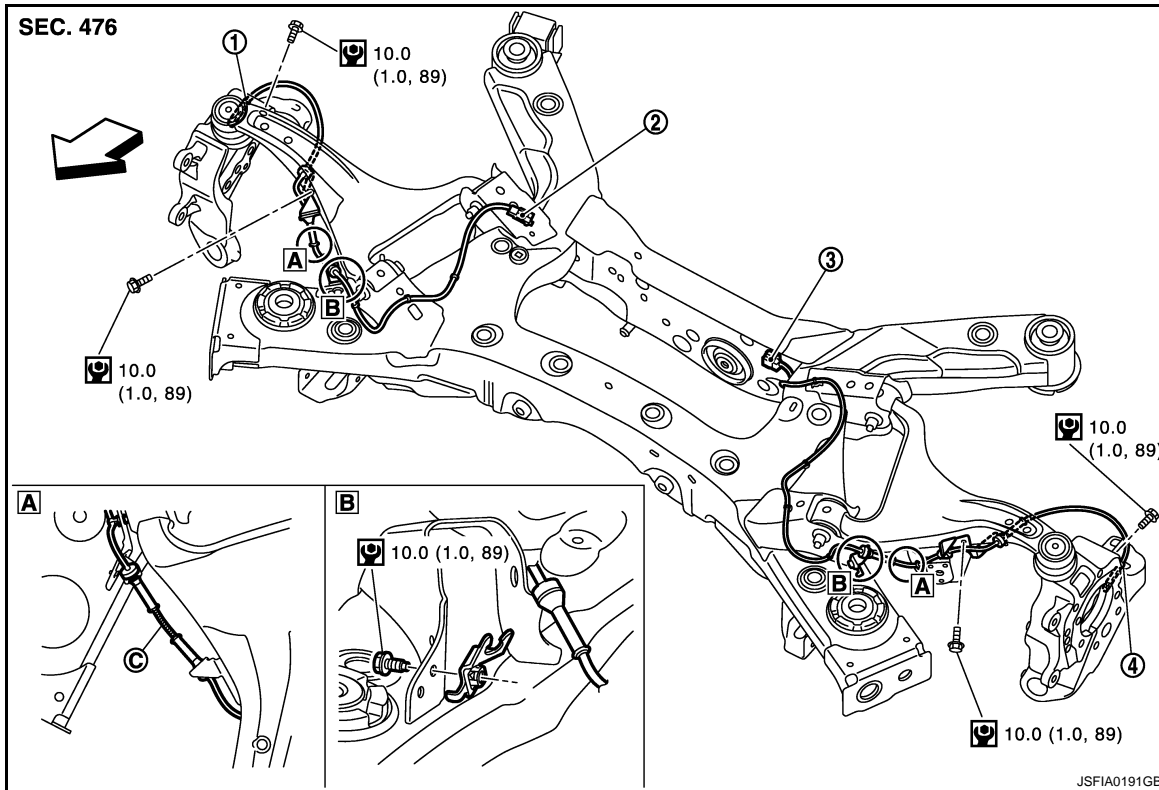

1. Rear RH wheel sensor
2. Rear RH wheel sensor connector
3. Rear LH wheel sensor connector
4. Rear LH wheel sensor

B. AWD models only C. White line (slant line)

↔ : Vehicle front

Refer to [GI-4, "Components"](#) for symbol in the figure.

REAR WHEEL SENSOR : Removal and Installation

INFOID:000000003247258

REMOVAL

Be careful with the following when removing sensor.

CAUTION:

- Do not twist sensor harness as much as possible, when removing it. Pull sensors out without pulling sensor harness.
- Be careful to avoid damaging sensor edges or rotor teeth. Remove wheel sensor first before removing front or rear wheel hub. This is to avoid damage to sensor wiring and loss of sensor function.

INSTALLATION

Be careful with the following when installing wheel sensor. Tighten installation bolts to the specified torques.

- When installing, make sure there is no foreign material such as iron chips on and in the mounting hole of the wheel sensor. Make sure no foreign material has been caught in the sensor rotor. Remove any foreign material and clean the mount.
- When installing wheel sensor, be sure to press rubber grommets in until they lock at locations shown above in the figure. When installed, harness must not be twisted.

SENSOR ROTOR

< ON-VEHICLE REPAIR >

[VDC/TCS/ABS]

SENSOR ROTOR FRONT SENSOR ROTOR

FRONT SENSOR ROTOR : Exploded View

INFOID:000000003247259

Refer to [FAX-10, "Exploded View"](#) (2WD models), [FAX-37, "Exploded View"](#) (AWD models).

FRONT SENSOR ROTOR : Removal and Installation

INFOID:000000003247260

REMOVAL

Sensor rotor cannot be disassembled. Remove the sensor rotor together with hub bearing assembly. Refer to [FAX-10, "Removal and Installation"](#) (2WD models), [FAX-37, "Removal and Installation"](#) (AWD models).

INSTALLATION

Sensor rotor cannot be disassembled. Install the sensor rotor together with hub bearing assembly. Refer to [FAX-10, "Removal and Installation"](#) (2WD models), [FAX-37, "Removal and Installation"](#) (AWD models).

REAR SENSOR ROTOR

REAR SENSOR ROTOR : Exploded View

INFOID:000000003247261

Refer to [RAX-5, "Exploded View"](#) (2WD models), [RAX-13, "Exploded View"](#) (AWD models).

REAR SENSOR ROTOR : Removal and Installation

INFOID:000000003247262

REMOVAL

Sensor rotor cannot be disassembled. Remove the sensor rotor together with hub bearing assembly. Refer to [RAX-5, "Removal and Installation"](#) (2WD models), [RAX-15, "Removal and Installation"](#) (AWD models).

INSTALLATION

Sensor rotor cannot be disassembled. Install the sensor rotor together with hub bearing assembly. Refer to [RAX-5, "Removal and Installation"](#) (2WD models), [RAX-15, "Removal and Installation"](#) (AWD models).

ABS ACTUATOR AND ELECTRIC UNIT (CONTROL UNIT)

< ON-VEHICLE REPAIR >

[VDC/TCS/ABS]

ABS ACTUATOR AND ELECTRIC UNIT (CONTROL UNIT)

Exploded View

INFOID:000000003247263

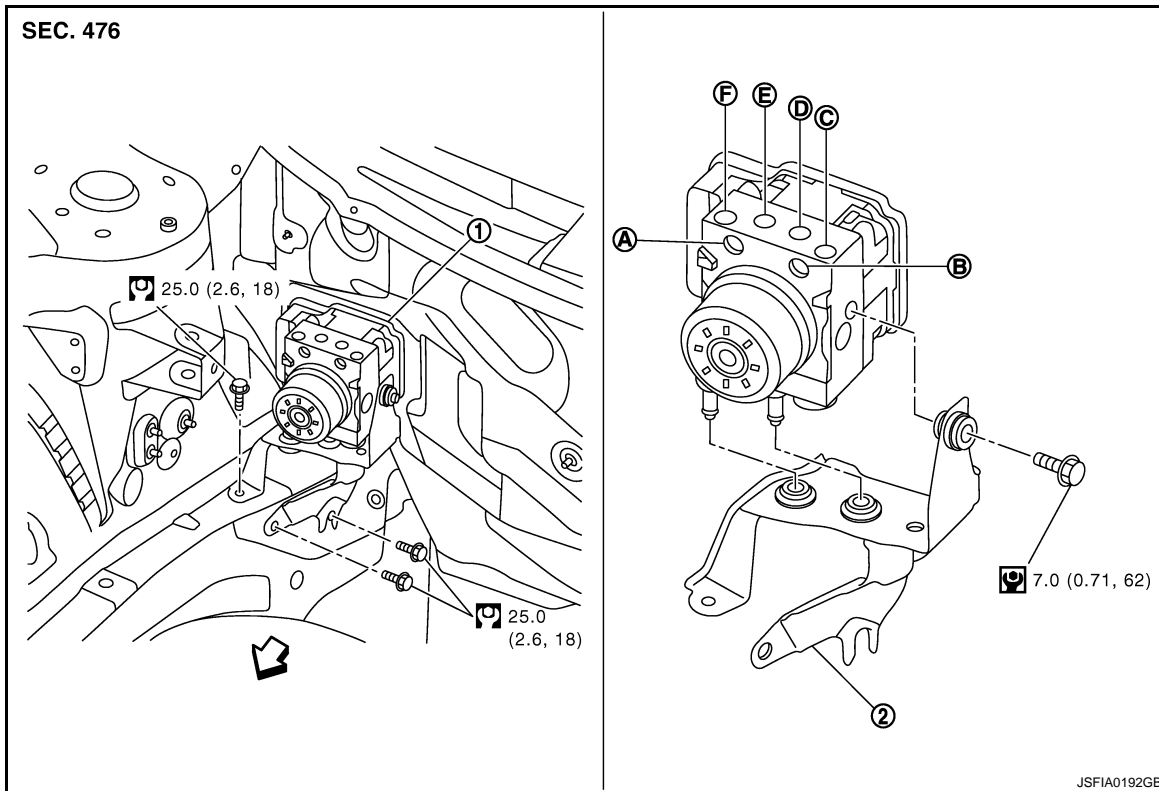

A
B
C
D
E
BRC
G
H
I

1. ABS actuator and electric unit (control unit) 2. Bracket

- A. To rear RH brake caliper B. To rear LH brake caliper C. From master cylinder primary side
D. To front RH brake caliper E. To front LH brake caliper F. From master cylinder secondary side

⇐ Vehicle front

Refer to [GI-4, "Components"](#) for symbol in the figure.

Removal and Installation

INFOID:000000003247264

REMOVAL

CAUTION:

- Before servicing, disconnect the battery cable from negative terminal.
- To remove brake tube, use a flare nut wrench to prevent flare nuts and brake tube from being damaged. To install, use flare nut crowfoot and torque wrench.
- Do not apply excessive impact to ABS actuator and electric unit (control unit), such as dropping it.
- Do not remove and install actuator by holding harness.

1. Remove cowl top. Refer to [EXT-20, "Exploded View"](#).
2. Disconnect ABS actuator and electric unit (control unit) connector.
3. Loosen brake tube flare nuts, then remove brake tubes from ABS actuator and electric unit (control unit).
4. Remove ABS actuator and electric unit (control unit) bracket mounting nut.
5. Remove ABS actuator and electric unit (control unit) from vehicle.

INSTALLATION

Note the following, and install in the reverse order of removal.

CAUTION:

- Before servicing, disconnect the battery cable from negative terminal.

J
K
L
M
N
O
P

ABS ACTUATOR AND ELECTRIC UNIT (CONTROL UNIT)

< ON-VEHICLE REPAIR >

[VDC/TCS/ABS]

- To remove brake tube, use a flare nut wrench to prevent flare nuts and brake tube from being damaged. To install, use flare nut crowfoot and torque wrench.
- Do not apply excessive impact to ABS actuator and electric unit (control unit), such as dropping it.
- Do not remove and install actuator by holding harness.
- After work is completed, bleed air from brake tube. Refer to [BR-13, "Bleeding Brake System"](#).
- After installing harness connector in the ABS actuator and electric unit (control unit), make sure connector is securely locked.
- After removing/replacing an ABS actuator and electric unit (control unit), be sure to perform the following procedure.
 - Adjustment of steering angle sensor neutral position: Refer to [BRC-9, "ADJUSTMENT OF STEERING ANGLE SENSOR NEUTRAL POSITION : Description"](#).
 - Calibration of yaw rate/side/decel G sensor: Refer to [BRC-10, "CALIBRATION OF YAW RATE/SIDE/DECEL G SENSOR : Description"](#).
 - Calibration of pressure sensor: Refer to [BRC-11, "CALIBRATION OF PRESSURE SENSOR : Description"](#).

Install ABS actuator and electric unit (control unit) as per the following steps.

1. Temporarily tighten mounting bolt (1) because the bracket (2) is temporarily being hold.
2. Tighten mounting bolt (3) while holding the bracket.
3. Tighten mounting bolts to the specified torque in the order of (4), (1).

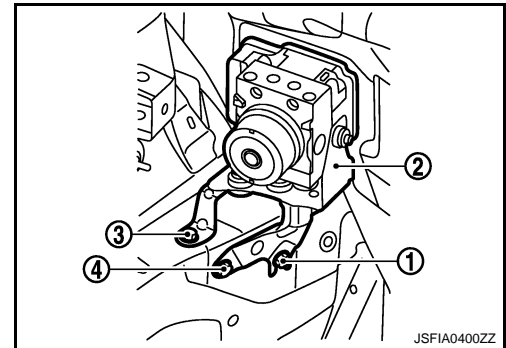

G SENSOR

Exploded View

INFOID:000000003247265

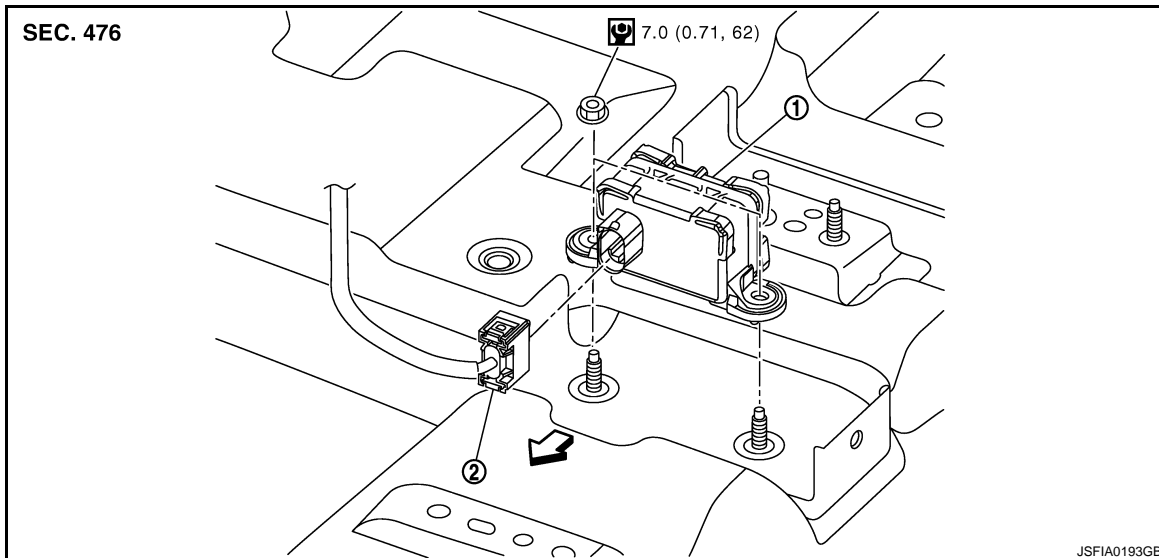

1. Yaw rate/side/decel G sensor 2. Connector

←: Vehicle front

Refer to [GI-4, "Components"](#) for symbol in the figure.

Removal and Installation

INFOID:000000003247266

REMOVAL

CAUTION:

Do not drop or strike yaw rate/side/decel G sensor, or do not use power tool etc., because yaw rate/side/decel G sensor is sensitive to the impact.

1. Remove center console assembly. Refer to [IP-19, "Exploded View"](#).
2. Disconnect yaw rate/side/decel G sensor harness connector.
3. Remove mounting nuts.
4. Remove yaw rate/side/decel G sensor.

INSTALLATION

Note the following, and install in the reverse order of removal.

CAUTION:

- **Do not drop or strike yaw rate/side/decel G sensor, or do not use power tool etc., because yaw rate/side/decel G sensor is sensitive to the impact.**
- **After work, make sure to calibration of yaw rate/side/decel G sensor. Refer to [BRC-10, "CALIBRATION OF YAW RATE/SIDE/DECEL G SENSOR : Description"](#).**

STEERING ANGLE SENSOR

< ON-VEHICLE REPAIR >

[VDC/TCS/ABS]

STEERING ANGLE SENSOR

Exploded View

INFOID:000000003247267

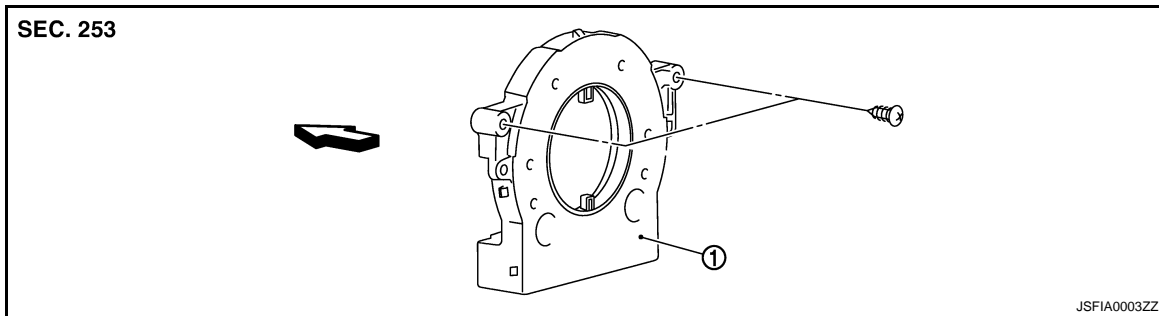

1. Steering angle sensor

↔: Vehicle front

Removal and Installation

INFOID:000000003247268

REMOVAL

1. Remove spiral cable assembly. Refer to [SR-8, "Exploded View"](#).
2. Remove steering angle sensor from spiral cable assembly.

INSTALLATION

Note the following, and install in the reverse order of removal.

CAUTION:

After work, make sure to adjust neutral position of steering angle sensor. Refer to [BRC-9, "ADJUSTMENT OF STEERING ANGLE SENSOR NEUTRAL POSITION : Description"](#).