

SECTION **PR**
PROPELLER SHAFT

A
B
C

PR

CONTENTS

E

PREPARATION	2	PROPELLER SHAFT VIBRATION	4	F
Commercial Service Tools	2	Removal and Installation	5	
NOISE, VIBRATION AND HARSHNESS (NVH)		COMPONENTS	5	
TROUBLESHOOTING	3	REMOVAL	5	G
NVH Troubleshooting Chart	3	INSPECTION	6	
REAR PROPELLER SHAFT	4	INSTALLATION	7	
On-Vehicle Inspection	4	SERVICE DATA AND SPECIFICATIONS (SDS)	8	H
APPEARANCE AND NOISE INSPECTION	4	General Specifications	8	
		Journal Axial Play	8	
		Propeller Shaft Runout	8	I

F

G

H

I

J

K

L

M

PREPARATION

PREPARATION

PFP:00002

Commercial Service Tools

NDS00084

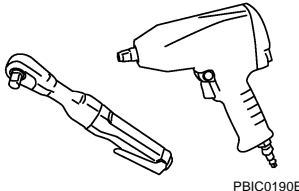
Tool name	Description
<p data-bbox="140 310 252 336">Power tool</p>  <p data-bbox="836 512 911 532">PBIC0190E</p>	<p data-bbox="999 310 1254 336">Loosening bolts and nuts</p>

NOISE, VIBRATION AND HARSHNESS (NVH) TROUBLESHOOTING

NOISE, VIBRATION AND HARSHNESS (NVH) TROUBLESHOOTING

PF0:00003

NVH Troubleshooting Chart

NDS00085

Use the chart below to help you find the cause of the symptom. If necessary, repair or replace these parts.

Symptom		Possible cause and SUSPECTED PARTS														Reference page	
		Uneven rotating torque	Center bearing improper installation	Excessive center bearing axial end play	Center bearing mounting (insulator) cracks, damage or deterioration	Excessive joint angle	Rotation imbalance	Excessive runout	DIFFERENTIAL	AXLE AND SUSPENSION	TIRES	ROAD WHEEL	DRIVE SHAFT	BRAKES	STEERING		
Noise	Noise	x	x	x	x	x	x	x	x	x	x	x	x	x	x	x	PR-4
	Shake		x			x				x							PR-7
	Vibration	x	x	x	x	x	x	x		x	x		x				PR-5
																	PR-6
																	PR-4
																	PR-6
																	NVH in RFD section
																	NVH in FAX, RAX, FSU, and RSU section
																	NVH in WT section
																	NVH in WT section
																	NVH in FAX and RAX section
																	NVH in BR section
																	NVH in PS section

x: Applicable

A
B
C
PR
E
F
G
H
I
J
K
L
M

REAR PROPELLER SHAFT

REAR PROPELLER SHAFT

PFP:37000

On-Vehicle Inspection

NDS00086

APPEARANCE AND NOISE INSPECTION

- Check the propeller shaft tube surface for dents or cracks. If damaged, replace propeller shaft assembly.
- If center bearing is noisy or damaged, replace propeller shaft assembly.

PROPELLER SHAFT VIBRATION

If vibration is present at high speed, inspect propeller shaft runout first.

1. Measure propeller shaft runout at runout measuring points by rotating final drive companion flange with hands.

Propeller shaft runout limit : 0.8 mm (0.031 in) or less

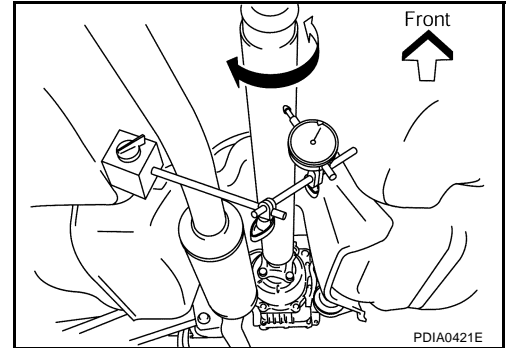

Propeller shaft runout measuring points

Dimension A: 509 mm (20.04 in)

B: 470 mm (18.50 in)

2. If runout still exceeds specifications, separate propeller shaft at final drive companion flange or transfer companion flange; then rotate companion flange 90, 180, 270 degrees and install propeller shaft.
3. Check runout again. If runout still exceeds specifications, replace propeller shaft assembly.
4. Check the vibration by driving vehicle.

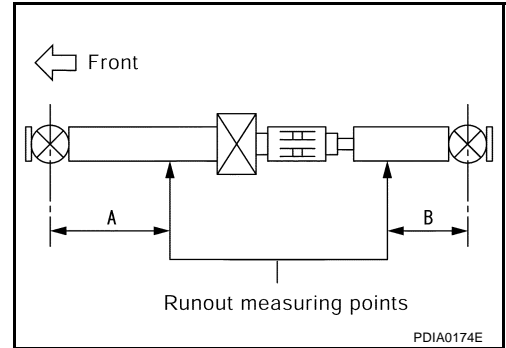

REAR PROPELLER SHAFT

NDS00087

Removal and Installation COMPONENTS

A
B
C
PR
E
F
G
H
I
J
K
L
M

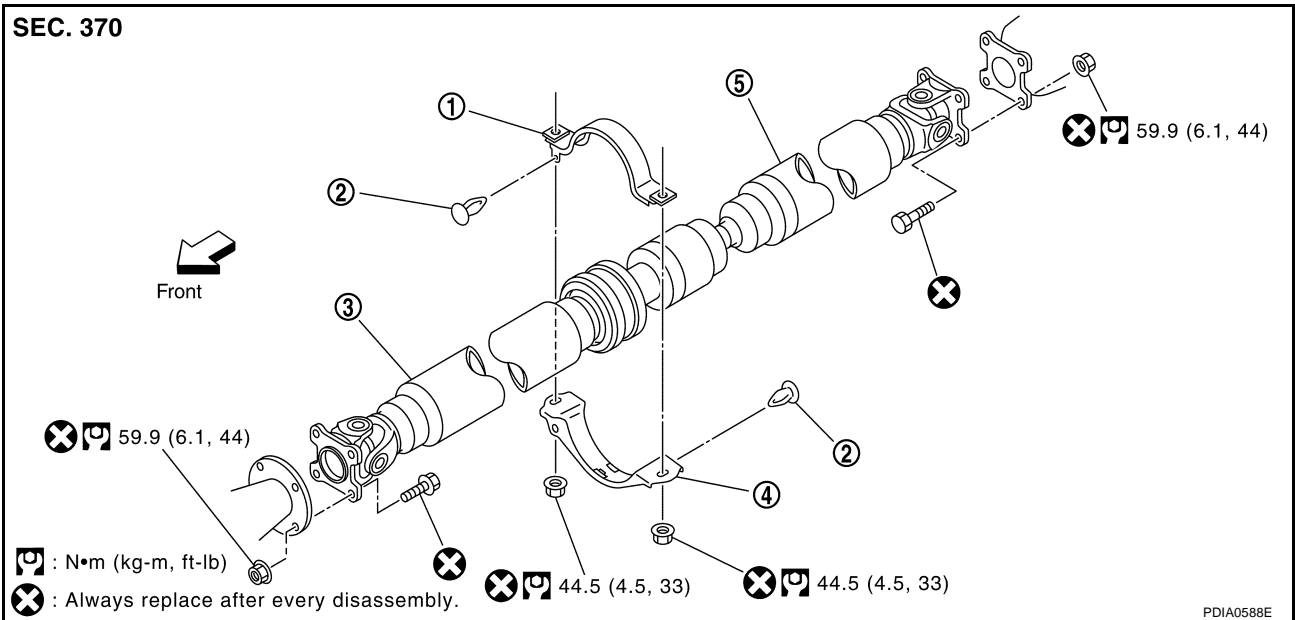

1. Center bearing mounting bracket (Upper)
2. Clip
3. Propeller shaft (1st shaft)
4. Center bearing mounting bracket (Lower)
5. Propeller shaft (2nd shaft)

REMOVAL

1. Move selector lever to N range position.
2. Release parking brake.
3. Put matching marks onto propeller shaft flange yoke and final drive and transfer companion flanges.

CAUTION:

For matching mark, use paint. Do not damage propeller shaft flange and companion flanges.

4. Loosen mounting nuts of center bearing mount brackets with power tool.
5. Remove fixing nuts and bolts from propeller shaft companion flanges.
6. Remove center bearing mounting bracket fixing nuts.
7. Remove propeller shaft.

CAUTION:

If constant velocity joint was bent during propeller shaft assembly removal, installation, or transportation, its boot may be damaged. Wrap boot interference area to metal part with shop cloth or rubber to protect boot from breakage.

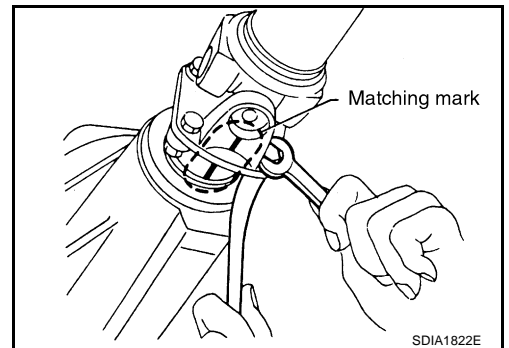

REAR PROPELLER SHAFT

INSPECTION

- Inspect propeller shaft runout at measuring points. If runout exceeds specifications, replace propeller shaft assembly.

Propeller shaft runout limit : 0.8 mm (0.031 in) or less

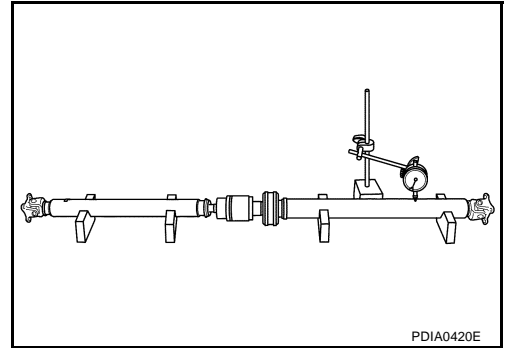

Propeller shaft runout measuring points

Dimension A: 509 mm (20.04 in)

B: 470 mm (18.50 in)

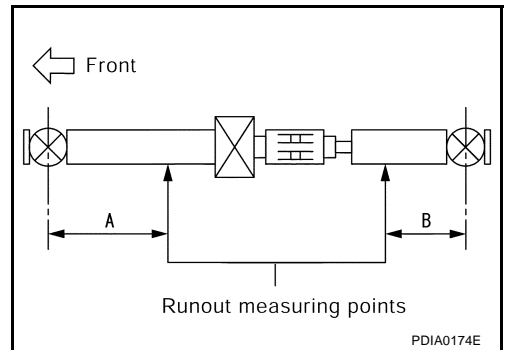

- As shown in the figure, while fixing yoke on one side, check axial play of joint. If outside the standard, replace propeller shaft assembly.

Journal axial play : 0 mm (0 in)

- Check propeller shaft for bend and damage. If damage is detected, replace propeller shaft assembly.

CAUTION:

Do not disassemble joints.

- Check center bearing for noise and damage. If noise or damage is detected, replace propeller shaft assembly.

CAUTION:

Do not disassemble center bearing.

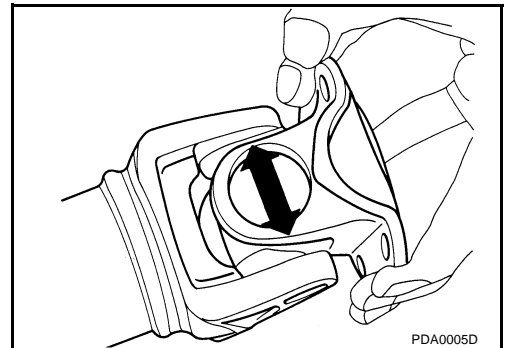

REAR PROPELLER SHAFT

INSTALLATION

Note the following, and install in the reverse order of removal.

- Align matching marks to install propeller shaft to final drive and transfer companion flanges, and then tighten to specified torque. Refer to [PR-5, "COMPONENTS"](#).
- Adjust position of mounting bracket sliding back and forth to prevent play in thrust direction of center bearing insulator. Install bracket to vehicle.
- After assembly, perform a driving test to check propeller shaft vibration. If vibration occurred, separate propeller shaft from final drive or transfer. Reinstall companion flange after rotating it by 90, 180, 270 degrees. Then perform driving test and check propeller shaft vibration again at each point.

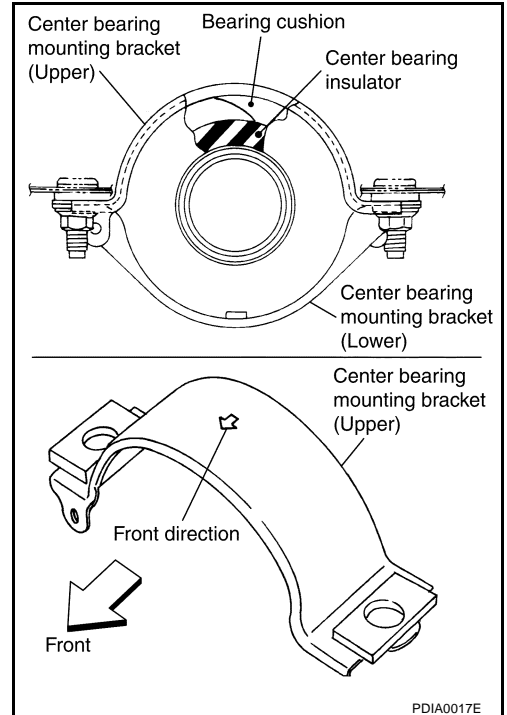

- If propeller shaft or final drive has been replaced, install them as follows;

1. Install propeller shaft while aligning its matching mark A with the matching mark B on the joint as close as possible.
2. Tighten fixing bolts and nuts to the specified torque. Refer to [PR-5, "COMPONENTS"](#).

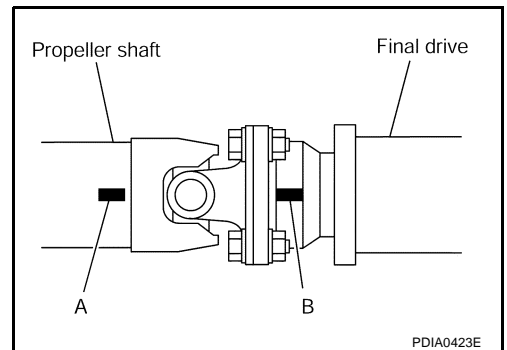

A
B
C
PR
E
F
G
H
I
J
K
L
M

SERVICE DATA AND SPECIFICATIONS (SDS)

SERVICE DATA AND SPECIFICATIONS (SDS)

PFP:00030

General Specifications

NDS00088

Applied model	VQ35DE	
Propeller shaft model	3F63A-DOJ75	
Number of joints	3	
Coupling method with transfer	Flange type	
Type of journal bearings	Shell type (Non-disassembly type)	
Shaft length	1st (Spider to cardan joint center)	1125 mm (44.29 in)
	2nd (Cardan joint center to spider)	1016 mm (40.00 in)
Shaft outer diameter	1st	75 mm (2.95 in)
	2nd	75 mm (2.95 in)

Journal Axial Play

NDS00089

Item	Specification
Journal axial play	0 mm (0 in)

Propeller Shaft Runout

NDS0008A

Item	Specification
Propeller shaft runout limit	0.8 mm (0.031 in) or less