

A  
B  
C  
D  
E  
F  
G  
H  
I  
J  
L  
M

# WW

## SECTION

# WIPER, WASHER & HORN

## CONTENTS

<b>PRECAUTION</b> .....	<b>3</b>	Front Wiper Interval Time Is Not Controlled by Vehicle Speed .....	28
Precautions for Supplemental Restraint System (SRS) "AIR BAG" and "SEAT BELT PRE-TENSIONER" .....	3	Front Wiper Intermittent Operation Switch Position Cannot Be Adjusted .....	28
<b>FRONT WIPER AND WASHER SYSTEM</b> .....	<b>4</b>	Wiper Does Not Wipe When Front Washer Operates .....	29
Components Parts and Harness Connector Location .....	4	After Front Wiper Operate for 10 Seconds, They Stop for 20 Seconds, and After Repeating the Operations Five Times, They Become Inoperative .....	30
System Description .....	4	Front Wiper Does Not Stop .....	31
LOW SPEED WIPER OPERATION .....	5	Removal and Installation of Front Wiper Arms, Adjustment of Wiper Arms Stop Location .....	32
HI SPEED WIPER OPERATION .....	5	REMOVAL .....	32
INTERMITTENT OPERATION .....	5	INSTALLATION .....	32
AUTO STOP OPERATION .....	6	ADJUSTMENT .....	32
WASHER OPERATION .....	6	Removal and Installation of Front Wiper Motor and Linkage .....	32
MIST OPERATION .....	7	REMOVAL .....	32
FAIL-SAFE FUNCTION .....	7	INSTALLATION .....	33
COMBINATION SWITCH READING FUNCTION .....	7	Disassembly and Assembly of Front Wiper Motor and Linkage .....	33
CAN Communication System Description .....	9	DISASSEMBLY .....	33
CAN Communication Unit .....	9	ASSEMBLY .....	33
Schematic .....	10	Washer Nozzle Adjustment .....	34
Wiring Diagram — WIPER — .....	11	Washer Tube Layout .....	35
Terminals and Reference Values for BCM .....	14	Removal and Installation of Front Washer Nozzle .....	35
Terminals and Reference Values for IPDM E/R .....	15	REMOVAL .....	35
How to Proceed With Trouble Diagnosis .....	15	INSTALLATION .....	35
Preliminary Check .....	15	Inspection for Washer Nozzle .....	35
CHECK POWER SUPPLY AND GROUND CIRCUIT .....	15	CHECK VALVE INSPECTION .....	35
CONSULT-II Functions (BCM) .....	17	Removal and Installation of Front Wiper and Washer Switch .....	36
CONSULT-II BASIC OPERATION .....	17	REMOVAL .....	36
WORK SUPPORT .....	18	INSTALLATION .....	36
DATA MONITOR .....	18	Removal and Installation of Washer Tank .....	36
ACTIVE TEST .....	19	REMOVAL .....	36
CONSULT-II Functions (IPDM E/R) .....	20	INSTALLATION .....	36
CONSULT-II BASIC OPERATION .....	20	Removal and Installation of Washer Pump .....	37
DATA MONITOR .....	21	REMOVAL .....	37
ACTIVE TEST .....	21	INSTALLATION .....	37
Front Wiper Does Not Operate .....	22		
Front Wiper Does Not Return to Stop Position .....	24		
Only Front Wiper Low Does Not Operate .....	25		
Only Front Wiper Hi Does Not Operate .....	26		
Only Front Wiper Intermittent Does Not Operate .....	28		

<b>REAR WIPER AND WASHER SYSTEM</b> .....	<b>38</b>	REMOVAL .....	51
Components Parts and Harness Connector Loca- tion .....	38	INSTALLATION .....	51
System Description .....	38	Removal and Installation of Rear Wiper Blade .....	52
OUT LINE .....	38	REMOVAL .....	52
REAR WIPER OPERATION .....	39	INSTALLATION .....	52
INTERMITTENT OPERATION .....	39	Washer Nozzle Adjustment .....	52
AUTO STOP OPERATION .....	39	Washer Tube Layout .....	53
WASHER OPERATION .....	39	Removal and Installation of Rear Washer Nozzle...	53
BCM WIPER SWITCH READING FUNCTION ...	39	Check Valve Inspection .....	54
Wiring Diagram — WIP/ R — .....	40	Removal and Installation of Rear Wiper and Washer Switch .....	54
Terminals and Reference Values for BCM .....	42	Removal and Installation of Washer Tank .....	54
How to Proceed With Trouble Diagnosis .....	43	Removal and Installation of Washer Pump .....	54
Preliminary Check .....	43	<b>POWER SOCKET</b> .....	<b>55</b>
CHECK POWER SUPPLY AND GROUND CIR- CUIT .....	43	Wiring Diagram — P/SCKT — .....	55
CONSULT-II Functions (BCM) .....	45	Removal and Installation of Instrument Power Socket .....	56
CONSULT-II BASIC OPERATION .....	45	REMOVAL .....	56
DATA MONITOR .....	46	INSTALLATION .....	56
ACTIVE TEST .....	46	Removal and Installation of Luggage Room Power Socket .....	56
Rear Wiper Does Not Operate .....	47	REMOVAL .....	56
Rear Wiper Does Not Return to Stop Position .....	48	INSTALLATION .....	56
Only Rear Wiper ON Does Not Operate .....	49	Removal and Installation of Console Power Socket...	56
Only Rear Wiper INT Does Not Operate .....	49	REMOVAL .....	56
Wiper Does Not Wipe When Rear Washer Operates..	49	INSTALLATION .....	56
Rear Wiper Do Not Stop .....	50	<b>HORN</b> .....	<b>57</b>
Removal and Installation of Rear Wiper Arm, Adjust- ment of Wiper Arms Stop Location .....	50	Wiring Diagram — HORN — .....	57
REMOVAL .....	50	Removal and Installation .....	58
INSTALLATION .....	50	REMOVAL .....	58
ADJUSTMENT .....	50	INSTALLATION .....	58
Removal and Installation of Rear Wiper Motor .....	51		

# PRECAUTION

## PRECAUTION

PPF:00011

### Precautions for Supplemental Restraint System (SRS) “AIR BAG” and “SEAT BELT PRE-TENSIONER”

AKS004MP

The Supplemental Restraint System such as “AIR BAG” and “SEAT BELT PRE-TENSIONER”, used along with a front seat belt, helps to reduce the risk or severity of injury to the driver and front passenger for certain types of collision. This system includes seat belt switch inputs and dual stage front air bag modules. The SRS system uses the seat belt switches to determine the front air bag deployment, and may only deploy one front air bag, depending on the severity of a collision and whether the front occupants are belted or unbelted. Information necessary to service the system safely is included in the SRS and SB section of this Service Manual.

#### **WARNING:**

- To avoid rendering the SRS inoperative, which could increase the risk of personal injury or death in the event of a collision which would result in air bag inflation, all maintenance must be performed by an authorized NISSAN/INFINITI dealer.
- Improper maintenance, including incorrect removal and installation of the SRS, can lead to personal injury caused by unintentional activation of the system. For removal of Spiral Cable and Air Bag Module, see the SRS section.
- Do not use electrical test equipment on any circuit related to the SRS unless instructed to in this Service Manual. SRS wiring harnesses can be identified by yellow and/or orange harnesses or harness connectors.

A  
B  
C  
D  
E  
F  
G  
H  
I  
J  
L  
M

WW

# FRONT WIPER AND WASHER SYSTEM

## FRONT WIPER AND WASHER SYSTEM

PF:28810

### Components Parts and Harness Connector Location

AKS004MS

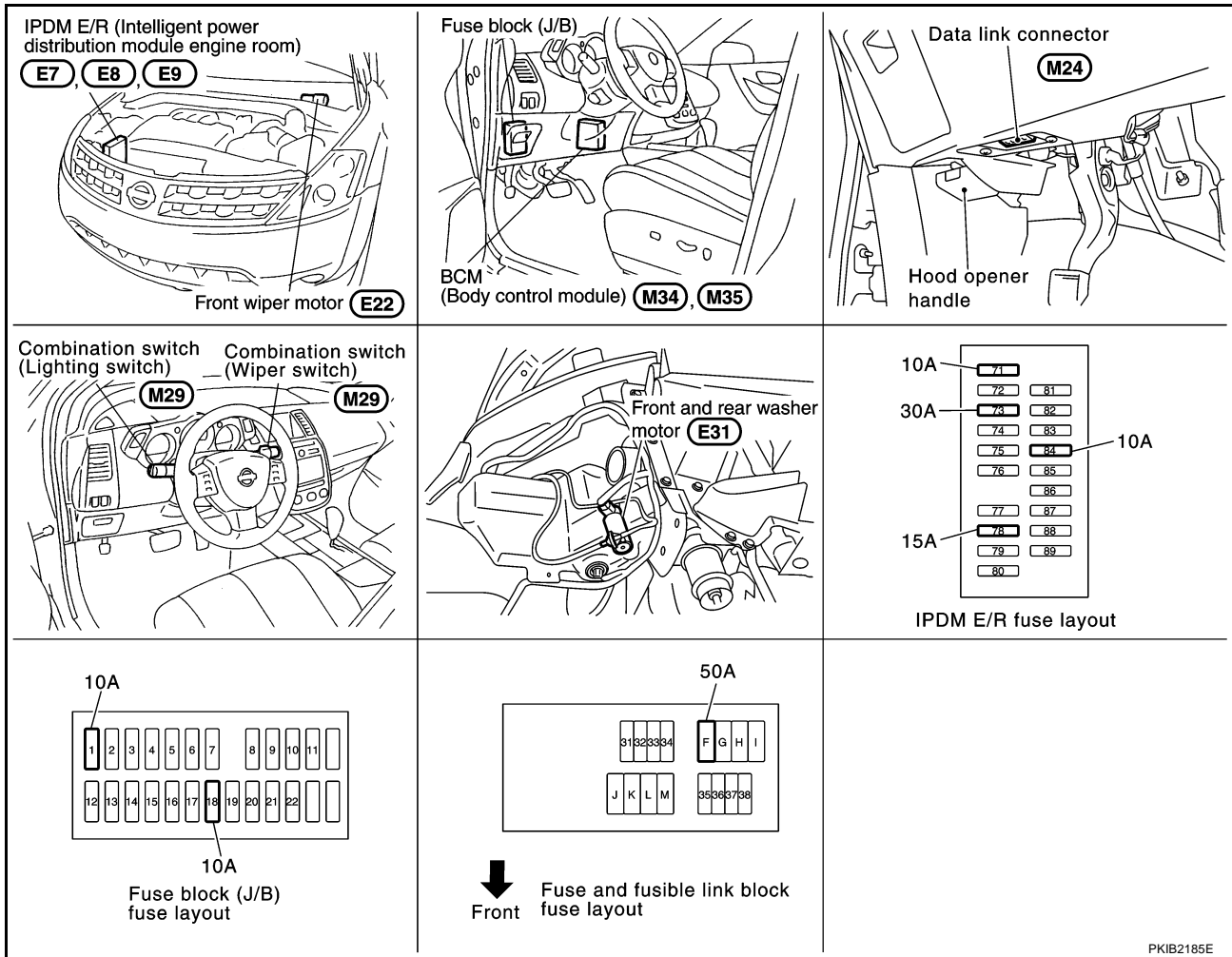

PKIB2185E

## System Description

AKS004MT

- All front wiper relays (HI, LO) are included in IPDM E/R (intelligent power distribution module engine room).
- Wiper switch (combination switch) is composed of a combination of 5 output terminals and 5 input terminals. Terminal combination status is read by BCM (body control module) when switch is turned ON.
- BCM controls front wiper LO, HI, and INT (intermittent) operation.
- IPDM E/R operates wiper motor according to CAN communication signals from BCM.

Power is supplied at all times

- to ignition relay, located in IPDM E/R, from battery direct,
- through 30 A fuse (No. 73 located in IPDM E/R)
- to front wiper relay, located in IPDM E/R,
- through 15 A fuse (No. 78 located in IPDM E/R)
- to CPU located in IPDM E/R,
- through 10 A fuse (No. 71, located in IPDM E/R)
- to CPU located in IPDM E/R,
- through 50 A fusible link (letter F, located in fuse and fusible link block)
- to BCM terminal 55,
- through 10 A fuse [No. 18 located in fuse block (J/B)]
- to BCM terminal 42.

When the ignition switch ON or START position, power is supplied

# FRONT WIPER AND WASHER SYSTEM

- to ignition relay, located in IPDM E/R, from battery direct,
- through 10 A fuse [No. 1 located in fuse block (J/B)]
- to BCM terminal 38,
- through 10 A fuse (No. 84 located in IPDM E/R)
- through IPDM E/R terminal 44
- to combination switch terminal 14.

Ground is supplied

- to BCM terminal 52
- through grounds E13, E26 and E28,
- to IPDM E/R terminals 38 and 60
- through grounds E13, E26 and E28
- to combination switch terminal 12
- through grounds M14 and M78.

## LOW SPEED WIPER OPERATION

When the front wiper switch is in LOW position, BCM detects low speed wiper ON signal by BCM wiper switch reading function.

BCM sent front wiper request signal (LO) with CAN communication line

- from BCM terminals 39 and 40
- to IPDM E/R terminals 48 and 49.

When the IPDM E/R receives front wiper request signal (LO), it turns ON front wiper relay, located in the IPDM E/R, power is supplied

- through IPDM E/R terminal 21 and front wiper high relay and front wiper relay
- to front wiper motor terminal 3.

Ground is supplied

- to front wiper motor terminal 1
- through grounds E13, E26 and E28.

With power and ground is supplied, the front wiper motor operates at low speed.

## HI SPEED WIPER OPERATION

When the front wiper switch is in HI position, BCM detects high speed wiper ON signal by BCM wiper switch reading function.

BCM sent front wiper request signal (HI) with CAN communication line

- from BCM terminals 39 and 40
- to IPDM E/R terminals 48 and 49.

When the IPDM E/R receives front wiper request signal (HI), it turns ON front wiper relay and front wiper high relay located in IPDM E/R, power is supplied

- through IPDM E/R terminal 31 and front wiper high relay and front wiper relay
- to front wiper motor terminal 2.

Ground is supplied

- to front wiper motor terminal 1
- through grounds E13, E26 and E28.

With power and ground is supplied, the front wiper motor operates at high speed.

## INTERMITTENT OPERATION

Front wiper intermittent operation delay interval is determined from a combination of 3 switches (intermittent operation dial position 1, 2, and 3) and vehicle speed signal.

After each intermittent operation delay interval, BCM sends front wiper request signal to IPDM E/R.

A

B

C

D

E

F

G

H

I

J

WW

L

M

# FRONT WIPER AND WASHER SYSTEM

## Wiper Dial Position Setting

Wiper dial position	Intermittent operation interval	Combination switch		
		Intermittent operation dial position 1	Intermittent operation dial position 2	Intermittent operation dial position 3
1	Short  ↑ ↓  Long	ON	ON	ON
2		ON	ON	OFF
3		ON	OFF	OFF
4		OFF	OFF	OFF
5		OFF	OFF	ON
6		OFF	ON	ON
7		OFF	ON	OFF

Example: For wiper dial position 1

Using combination switch reading function, BCM detects ON/OFF status of intermittent operation dial positions 1, 2, and 3.

When combination switch status is as listed below, BCM determines that it is wiper dial position 1.

- Intermittent operation dial position 1: ON (Continuity exists between combination switch output 3 and input 1.)
- Intermittent operation dial position 2: ON (Continuity exists between combination switch output 5 and input 1.)
- Intermittent operation dial position 3: ON (Continuity exists between combination switch output 4 and input 2.)

BCM determines front wiper intermittent operation delay interval from wiper dial position 1 and vehicle speed, and sends wiper request signal (INT) to IPDM E/R.

### AUTO STOP OPERATION

With wiper switch turned OFF, wiper motor will continue to operate until wiper arms reach windshield base. When wiper arms are not located at base of windshield with wiper switch OFF, power is provided

- from IPDM E/R terminal 21
- to front wiper motor terminal 3, in order to continue wiper motor operation at low speed.

When wiper arms reach base of windshield, front wiper motor terminals 1 and 4 are connected, and ground is supplied

- to IPDM E/R terminal 32
- through front wiper motor terminal 4
- through front wiper motor terminal 1
- through grounds E13, E26 and E28.

Then the IPDM E/R sends auto stop operation signal to BCM with CAN communication line.

When the BCM receives auto-stop operation signal, BCM sends wiper stop signal to IPDM E/R with CAN communication line.

IPDM E/R stops wiper motor. Wiper motor will then stop wiper arms at the STOP position.

### WASHER OPERATION

When the wiper switch is in front wiper washer position, BCM detects front wiper washer signal by BCM wiper switch reading function (Refer to [WW-7, "COMBINATION SWITCH READING FUNCTION"](#) ), combination switch power is supplied

- through combination switch terminal 13
- to front and rear washer motor terminal 1

Ground is supplied

- to front and rear washer motor terminal 2
- through combination switch terminal 11
- to combination switch terminal 12
- through grounds M14 and M78.

With ground is supplied, front and rear washer motor is operated.

# FRONT WIPER AND WASHER SYSTEM

When BCM detects that front and rear washer motor has operated for 0.4 seconds or longer, BCM operates front wiper motor for low speed.  
 When BCM detects washer switch is OFF, low speed operation cycles approximately 2 times and stops.

## MIST OPERATION

When the wiper switch is turned to the mist position, wiper low speed operation cycles once and then stops.  
 For additional information about wiper operation under this condition. Refer to [WW-5, "LOW SPEED WIPER OPERATION"](#).

If the switch is held in the mist position, low speed operation continues.

## FAIL-SAFE FUNCTION

If an abnormality occurs in CAN communications, IPDM E/R holds the condition just before fail-safe status is initiated until ignition switch is turned OFF. (If wipers were operating in LO just before the initiation of fail-safe status, they continue to operate in LO until ignition switch is turned OFF.)

## COMBINATION SWITCH READING FUNCTION

### Description

- BCM reads combination switch (wiper) status, and controls related systems such as head lamps and wipers, according to the results.
- BCM reads information of a maximum of 20 switches by combining five output terminals (OUTPUT 1-5) and five input terminals (INPUT 1-5).

### Operation Description

- BCM activates transistors of output terminals (OUTPUT 1-5) periodically and, and allows current to flow in turn.
- If any (1 or more) switches are turned ON, circuit of output terminals (OUTPUT 1-5) and input terminals (INPUT 1-5) becomes active.
- At this time, transistors of output terminals (OUTPUT 1-5) are activated to allow current to flow. When voltage of input terminals (INPUT 1-5) corresponding to that switch changes, interface in BCM detects voltage change, and BCM determines that switch is ON.

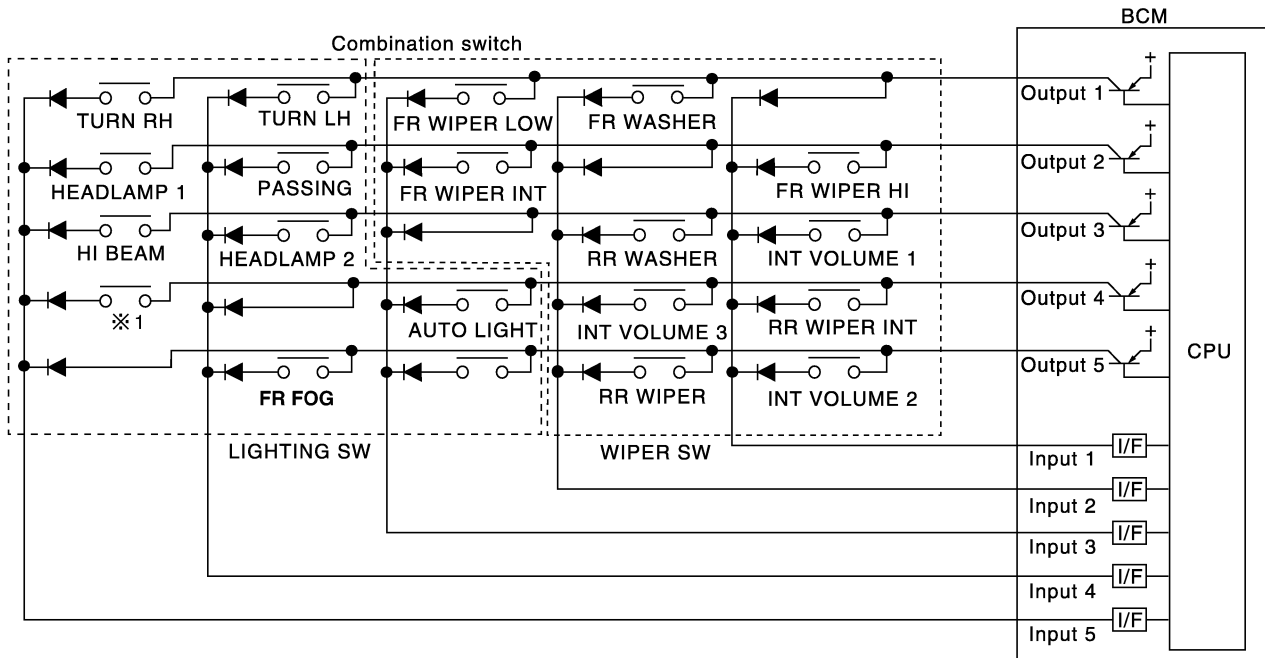

※ 1 : LIGHTING SWITCH 1ST POSITION

SKIA4958E

# FRONT WIPER AND WASHER SYSTEM

## BCM - Operation Table of Combination Switches

- BCM reads operation status of combination switch using combinations shown in table below.

	COMB SW OUTPUT 1		COMB SW OUTPUT 2		COMB SW OUTPUT 3		COMB SW OUTPUT 4		COMB SW OUTPUT 5	
	ON	OFF	ON	OFF	ON	OFF	ON	OFF	ON	OFF
COMB SW INPUT 1	—	—	FR WIPER HI ON	FR WIPER HI OFF	INT VOLUME 1 ON	INT VOLUME 1 OFF	RR WIPER INT ON	RR WIPER INT OFF	INT VOLUME 2 ON	INT VOLUME 2 OFF
COMB SW INPUT 2	FR WASHER ON	FR WASHER OFF	—	—	RR WASHER ON	RR WASHER OFF	INT VOLUME 3 ON	INT VOLUME 3 OFF	RR WIPER ON	RR WIPER OFF
COMB SW INPUT 3	FR WIPER LOW ON	FR WIPER LOW OFF	FR WIPER INT ON	FR WIPER INT OFF	—	—	AUTO LIGHT ON	AUTO LIGHT OFF	—	—
COMB SW INPUT 4	TURN LH ON	TURN LH OFF	PASSING ON	PASSING OFF	HEAD-LAMP 2 ON	HEAD-LAMP 2 OFF	—	—	FR FOG ON	FR FOG OFF
COMB SW INPUT 5	TURN RH ON	TURN RH OFF	HEAD-LAMP 1 ON	HEAD-LAMP 1 OFF	HI BEAM ON	HI BEAM OFF	LIGHTING SW (1st) ON	LIGHTING SW (1st) OFF	—	—

SKIA4959E

### Sample Operation: (When Wiper Switch Turned to LOW Position)

- When wiper switch is turned to LOW position, front wiper LOW contact in combination switch turns ON. At this time if OUTPUT 1 transistor is activated, BCM detects that voltage changes in INPUT 3.
- When BCM detects that voltage changes in INPUT 3 while OUTPUT 1 transistor is ON, it judges that front wiper switch is in LOW position. Then BCM sends front wiper request signal (LO) to IPDM E/R using CAN communication.
- If BCM detects that voltage changes in INPUT 3 when OUTPUT 1 transistor is activated again, it recognizes that wiper switch is still in LOW position.

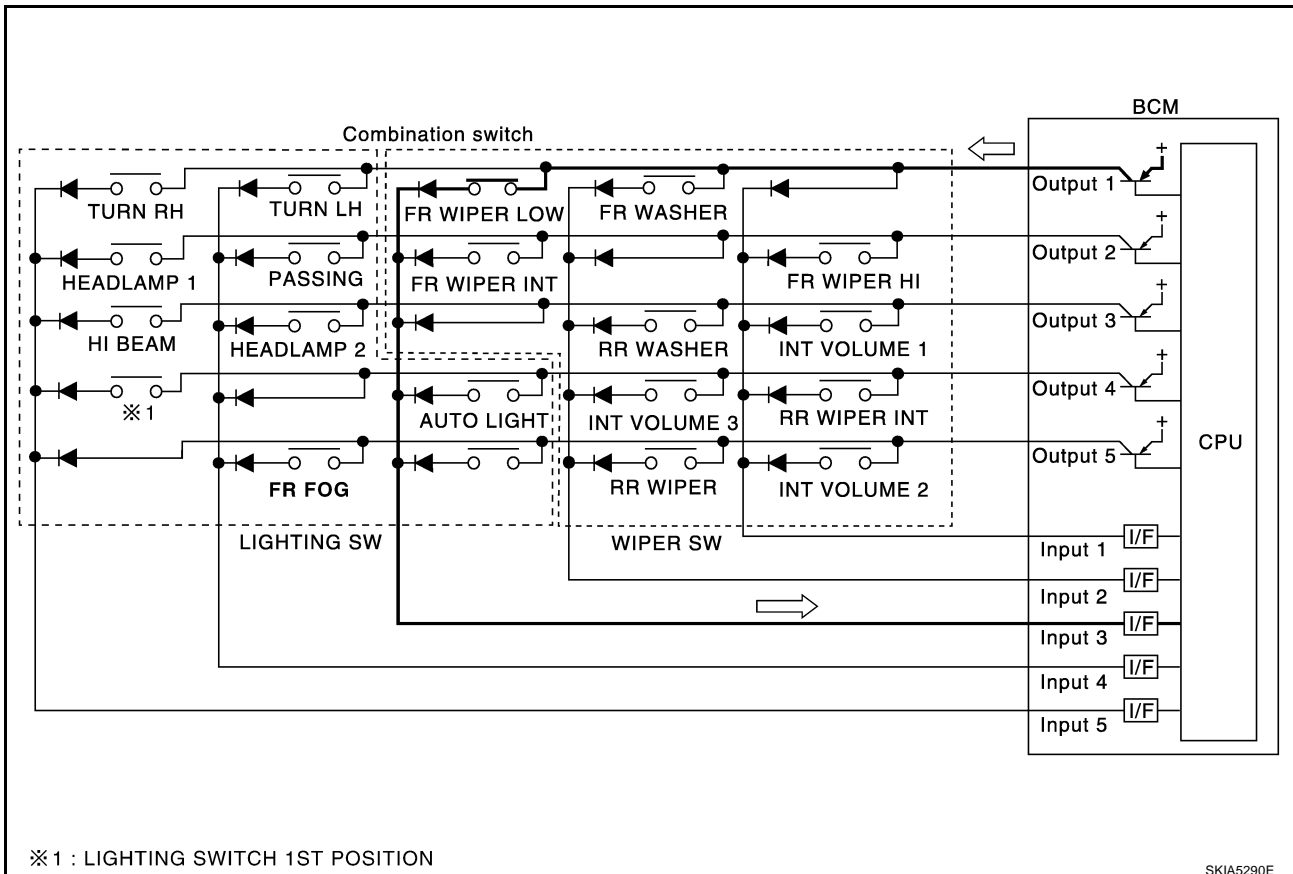

SKIA5290E



# FRONT WIPER AND WASHER SYSTEM

## NOTE:

Each OUTPUT terminal transistor is activated at 10 ms intervals. Therefore after switch is turned ON, electrical loads are activated with time delay. But this time delay is so short that it cannot be detected by human senses.

## Operation Mode

Combination switch reading function has operation modes shown below.

### 1. Normal status

- When BCM is not in sleep status, OUTPUT terminals (1-5) each turn ON-OFF every 10 ms.

### 2. Sleep status

- When BCM is in sleep status, transistors of OUTPUT (1 and 5) stop the output, and BCM enters low current consumption mode. OUTPUT (2, 3, and 4) turn ON-OFF every 60 ms, and only input from light switch system is accepted.

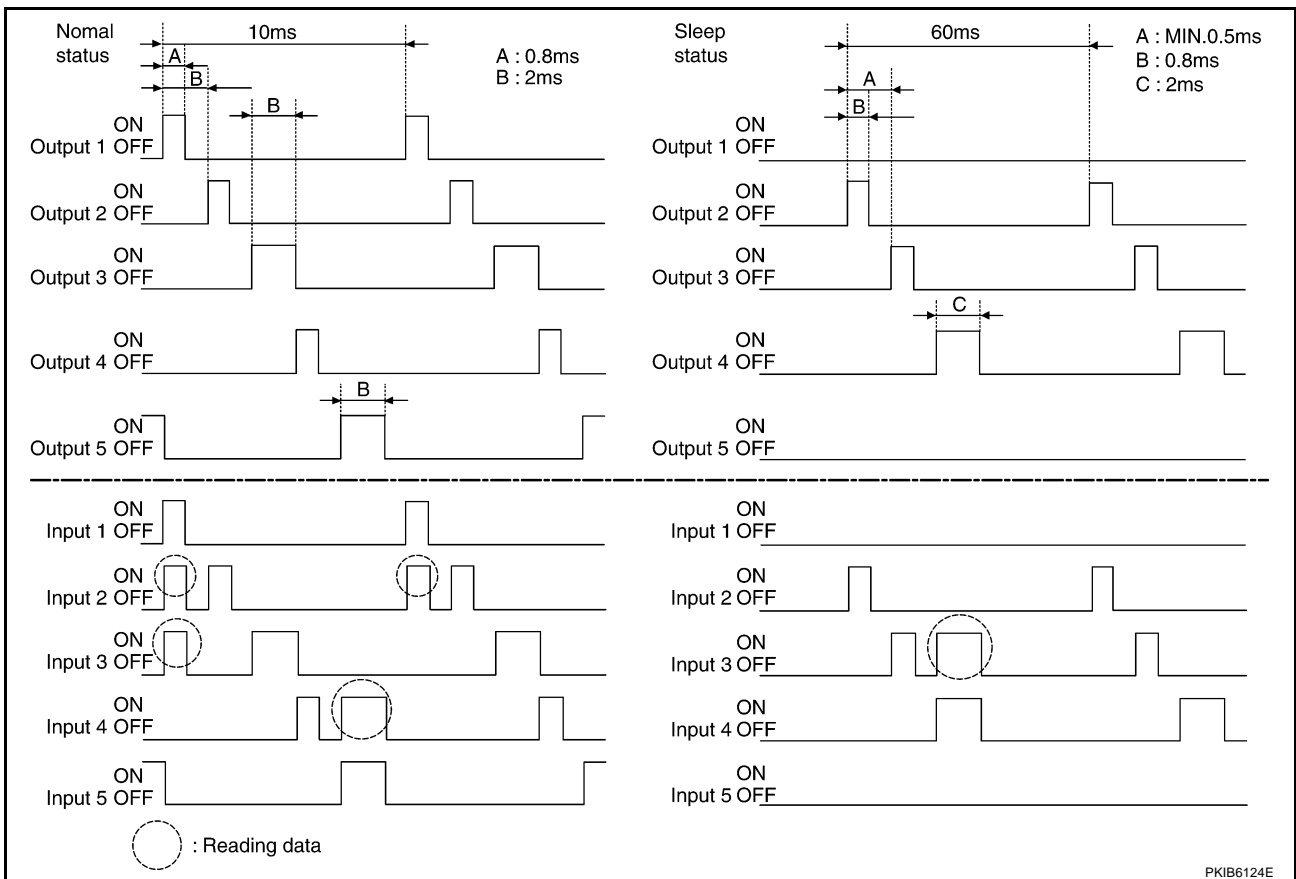

## CAN Communication System Description

AKS005MC

CAN (Controller Area Network) is a serial communication line for real time application. It is an on-vehicle multiplex communication line with high data communication speed and excellent error detection ability. Many electronic control units are equipped onto a vehicle, and each control unit shares information and links with other control units during operation (not independent). In CAN communication, control units are connected with 2 communication lines (CAN H line, CAN L line) allowing a high rate of information transmission with less wiring. Each control unit transmits/receives data but selectively reads required data only.

## CAN Communication Unit

AKS007R1

Refer to [LAN-29, "CAN Communication Unit"](#) .

# FRONT WIPER AND WASHER SYSTEM

## Schematic

AKS004MV

\* : This relay is built into the IPDM E/R  
(Intelligent power distribution module engine room).

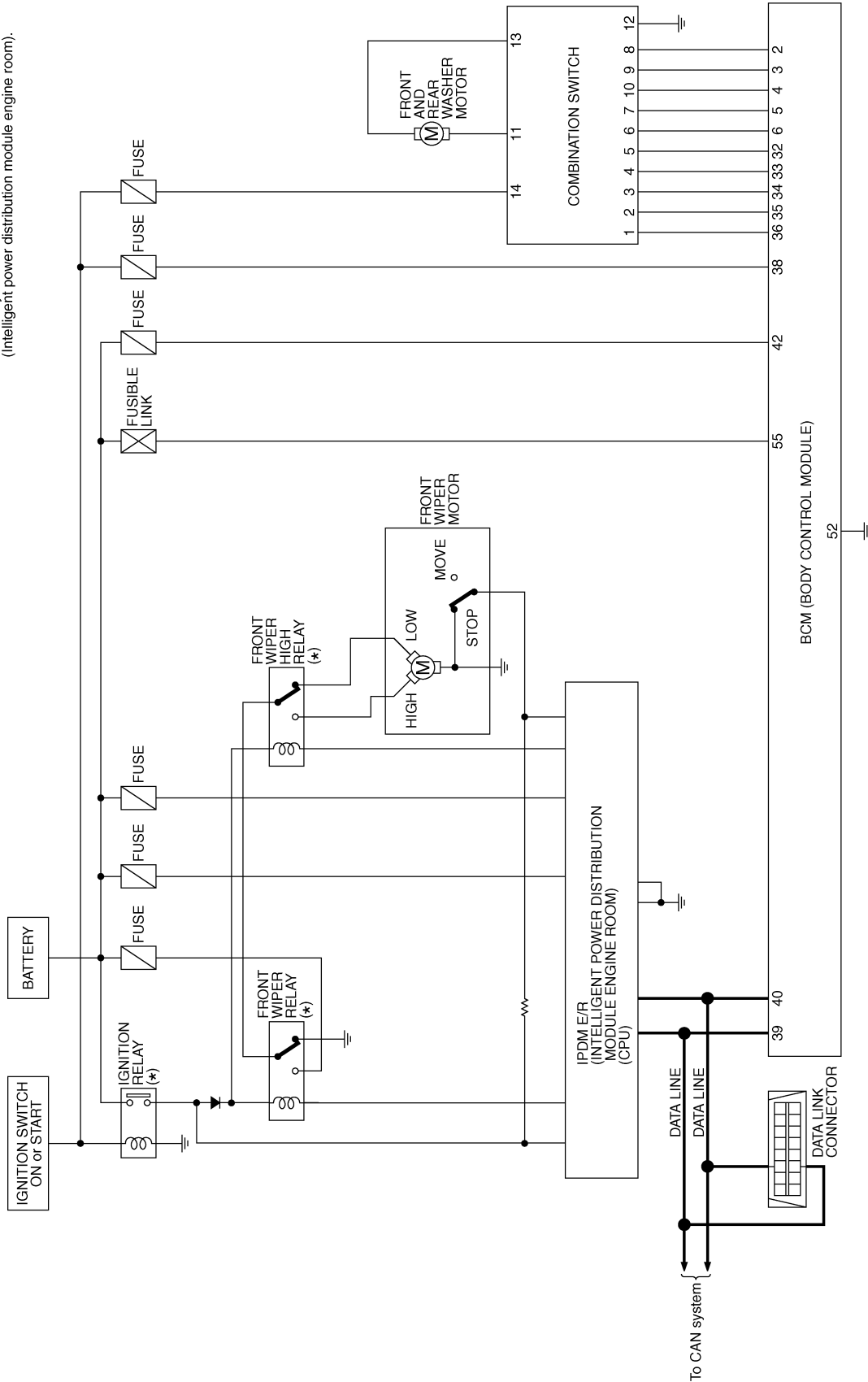

TKWB0495E

# FRONT WIPER AND WASHER SYSTEM

## Wiring Diagram — WIPER —

AKS004MW

WW-WIPER-01

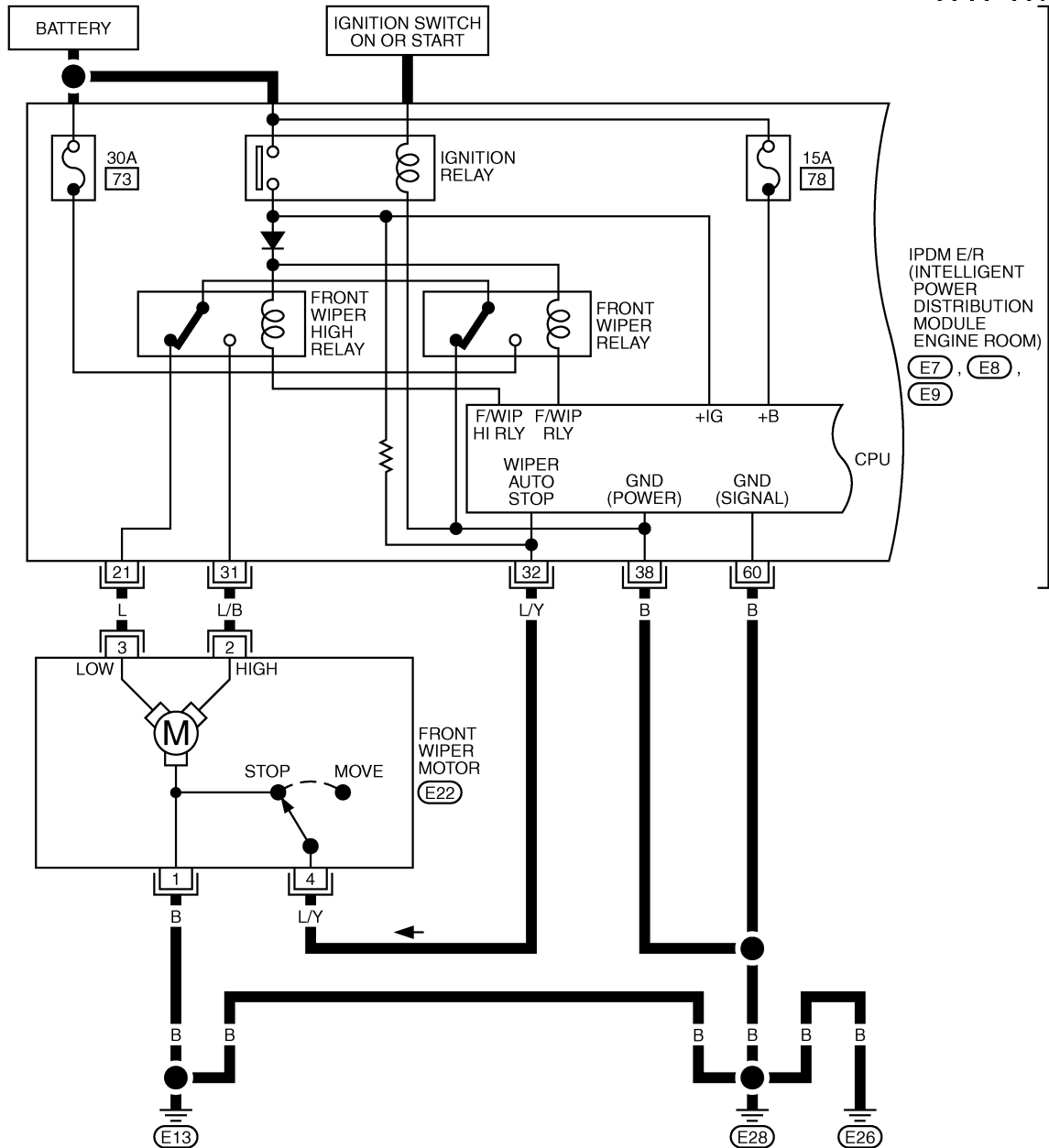

IPDM E/R  
(INTELLIGENT  
POWER  
DISTRIBUTION  
MODULE  
ENGINE ROOM)  
E7, E8,  
E9

REFER TO  
PG-POWER.

A  
B  
C  
D  
E  
F  
G  
H  
I  
J  
K  
L  
M

WW

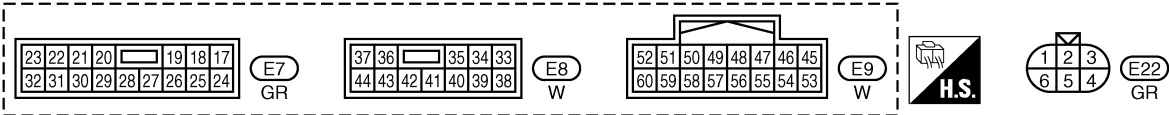

TKWA1715E

# FRONT WIPER AND WASHER SYSTEM

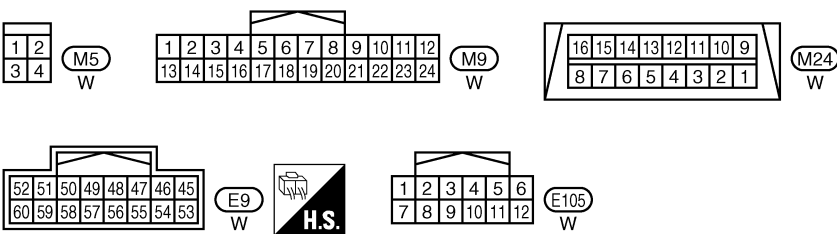
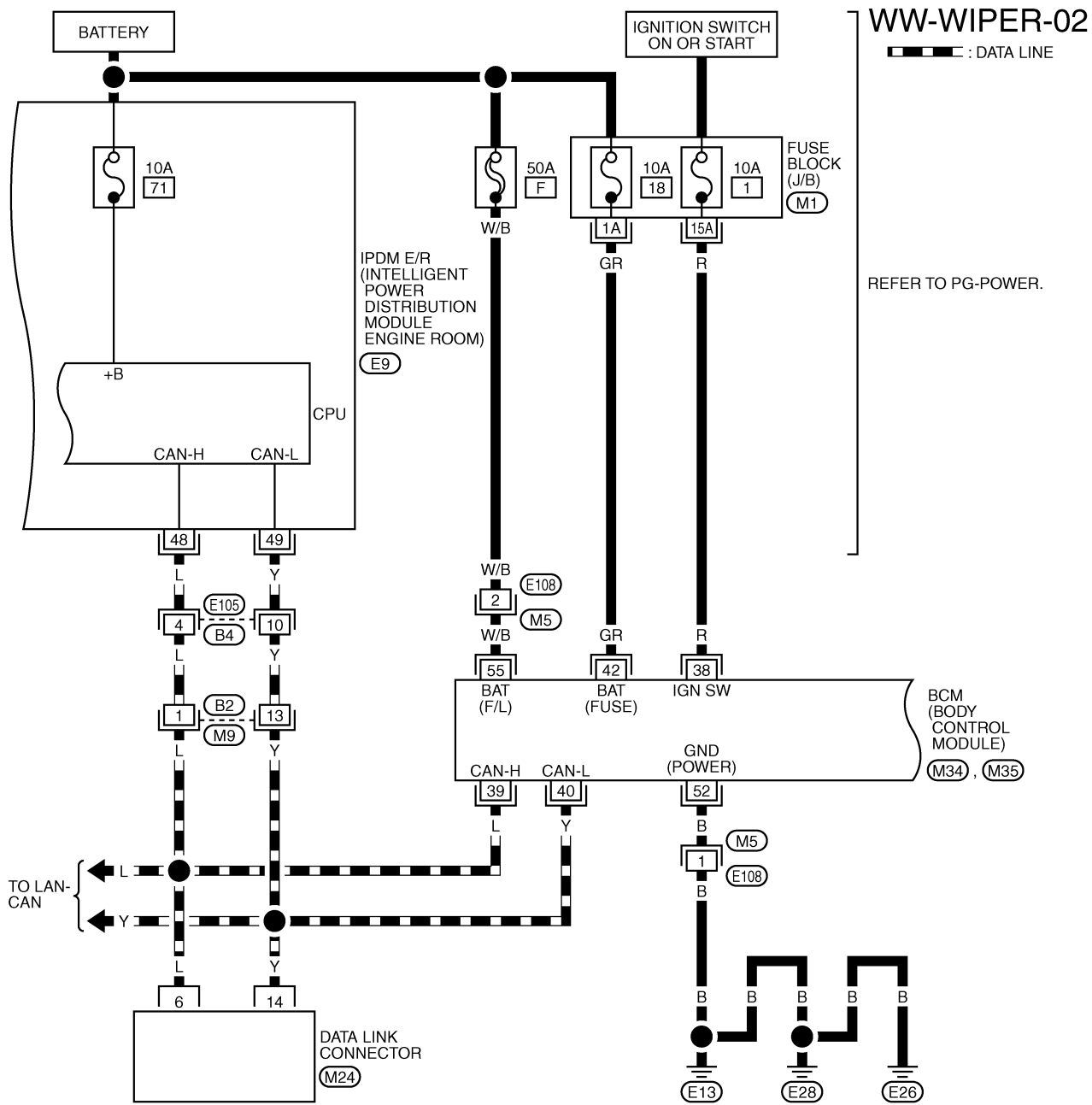

REFER TO THE FOLLOWING.  
 (M1) -FUSE BLOCK-JUNCTION BOX (J/B)  
 (M34), (M35) -ELECTRICAL UNITS

TKWB0496E

# FRONT WIPER AND WASHER SYSTEM

WW-WIPER-03

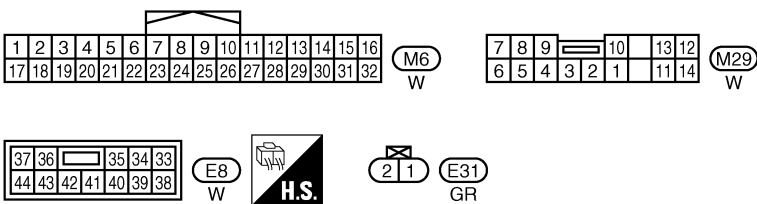
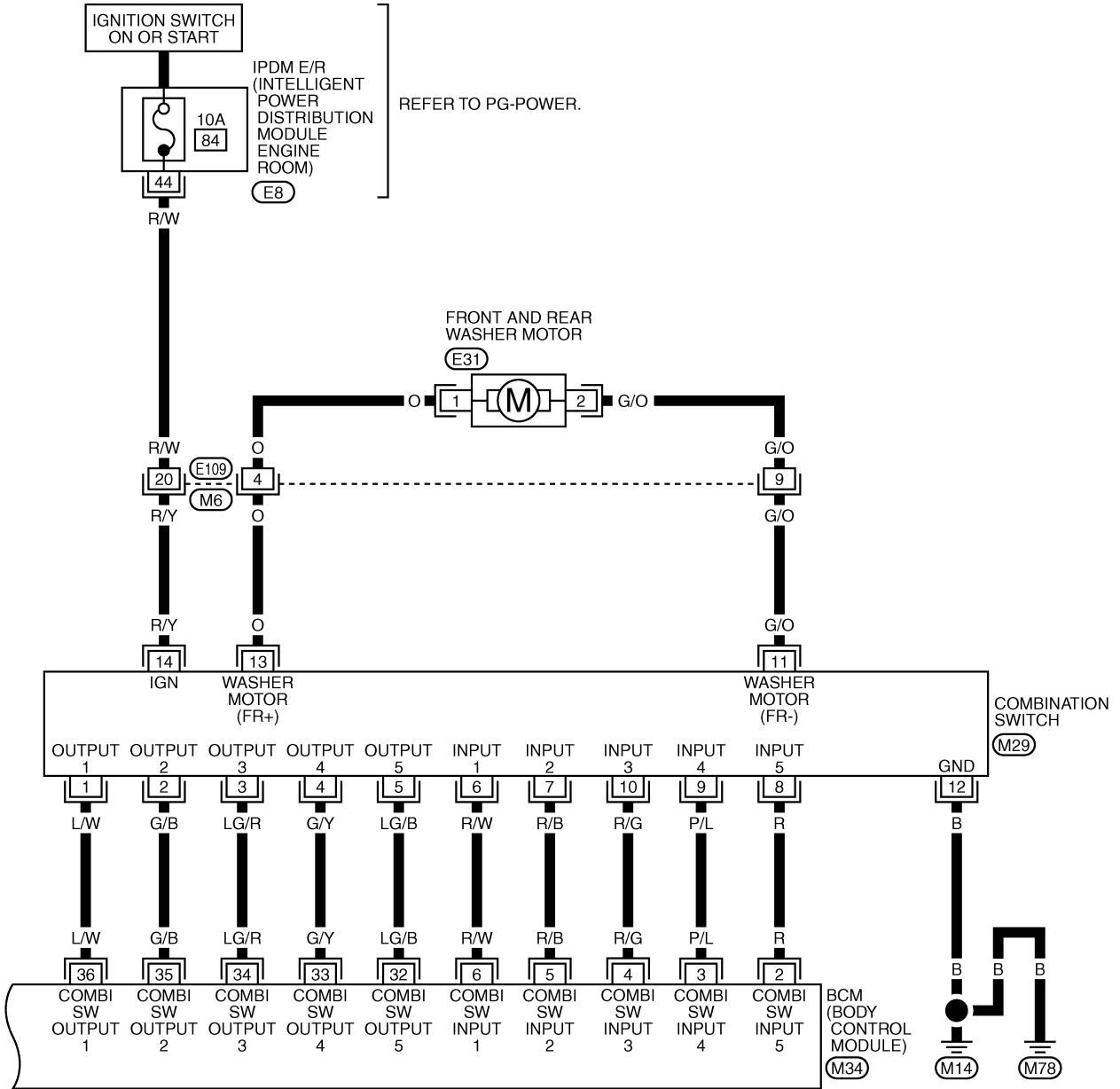

REFER TO THE FOLLOWING.  
 (M34) -ELECTRICAL UNITS



A  
B  
C  
D  
E  
F  
G  
H  
I  
J  
K  
L  
M

WW

# FRONT WIPER AND WASHER SYSTEM

## Terminals and Reference Values for BCM

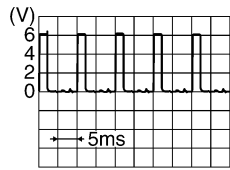
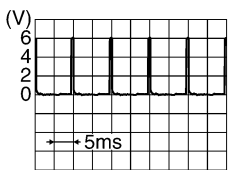
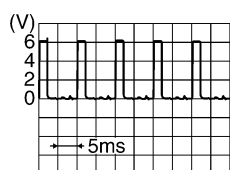
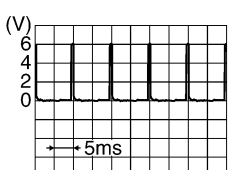
AKS00CRI

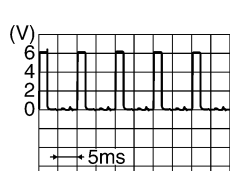
Terminal No.	Wire color	Signal name	Measuring condition		Reference value
			Ignition switch	Operation or condition	
2	R	Combination switch input 5	ON	Lighting switch and wiper switch OFF Wiper dial position 4	 <p style="text-align: right;">SKIA5291E</p>
3	P/L	Combination switch input 4	ON	Lighting switch and wiper switch OFF Wiper dial position 4	 <p style="text-align: right;">SKIA5292E</p>
4	R/G	Combination switch input 3	ON	Lighting switch and wiper switch OFF Wiper dial position 4	 <p style="text-align: right;">SKIA5291E</p>
5	R/B	Combination switch input 2	ON	Lighting switch and wiper switch OFF Wiper dial position 4	 <p style="text-align: right;">SKIA5292E</p>
6	R/W	Combination switch input 1	ON		
32	LG/B	Combination switch output 5	ON	Lighting switch and wiper switch OFF Wiper dial position 4	 <p style="text-align: right;">SKIA5291E</p>
33	G/Y	Combination switch output 4	ON	Lighting switch and wiper switch OFF Wiper dial position 4	 <p style="text-align: right;">SKIA5292E</p>
34	LG/R	Combination switch output 3	ON	Lighting switch and wiper switch OFF Wiper dial position 4	 <p style="text-align: right;">SKIA5291E</p>

# FRONT WIPER AND WASHER SYSTEM

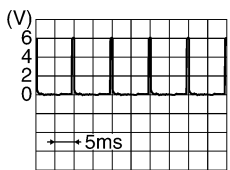
Terminal No.	Wire color	Signal name	Measuring condition		Reference value
			Ignition switch	Operation or condition	
35	G/B	Combination switch output 2	ON	Lighting switch and wiper switch OFF Wiper dial position 4	 <small>SKIA5292E</small>
36	L/W	Combination switch output 1			
38	R	Ignition switch (ON)	ON	—	Battery voltage
39	L	CAN – H	—	—	—
40	Y	CAN – L	—	—	—
42	GR	Battery power supply	OFF	—	Battery voltage
52	B	Ground	ON	—	Approx. 0V
55	W/B	Battery power supply	OFF	—	Battery voltage

## Terminals and Reference Values for IPDM E/R

AKS00CRJ

Terminal No.	Wire color	Signal name	Measuring condition		Reference value	
			Ignition switch	Operation or condition		
21	L	Low speed signal	ON	Wiper switch	OFF	Approx. 0V
					LOW	Battery voltage
31	L/B	High speed signal	ON	Wiper switch	OFF	Approx. 0V
					HI	Battery voltage
32	L/Y	Wiper auto - stop signal	ON	Wiper operating		Battery voltage
				Wiper stopped		Approx. 0V
38	B	Ground	ON	—	Approx. 0V	
44	R/W	Washer motor power supply	ON	—	Battery voltage	
48	L	CAN – H	—	—	—	
49	Y	CAN – L	—	—	—	
60	B	Ground	ON	—	Approx. 0V	

## How to Proceed With Trouble Diagnosis

AKS00AMU

1. Confirm the symptoms and customer complaint.
2. Understand operation description and function description. Refer to [WW-4, "System Description"](#) .
3. Perform the preliminary check. Refer to [WW-15, "Preliminary Check"](#) .
4. Check symptom and repair or replace the cause of malfunction.
5. Does the front wiper and washer operate normally? If YES, GO TO 6. If NO, GO TO 4.
6. INSPECTION END

## Preliminary Check

AKS00AMV

### CHECK POWER SUPPLY AND GROUND CIRCUIT

#### 1. CHECK FUSE

- Check for blown fuses.

Unit	Power source	Fuse and fusible link No.
Front wiper motor, front wiper relay, front wiper high relay	Battery	73

# FRONT WIPER AND WASHER SYSTEM

Unit	Power source	Fuse and fusible link No.
BCM	Battery	F
		18
	Ignition ON or START	1
Front and rear washer motor via combination switch	Ignition ON or START	84

Refer to [WW-11, "Wiring Diagram — WIPER —"](#).

**OK or NG**

OK >> GO TO 2.

NG >> If fuse is blown, be sure to eliminate cause of malfunction before installing new fuse. Refer to [PG-3, "POWER SUPPLY ROUTING CIRCUIT"](#).

## 2. CHECK POWER SUPPLY CIRCUIT

1. Turn ignition switch OFF.
2. Disconnect BCM connector.
3. Check voltage between BCM harness connector terminal and ground.

Terminal (+)		Terminal (-)	Ignition switch position	
Connector	Terminal (Wire color)		OFF	ON
M35	42 (GR)	Ground	Battery voltage	Battery voltage
M35	55 (W/B)		Battery voltage	Battery voltage
M34	38 (R)		Approx. 0V	Battery voltage

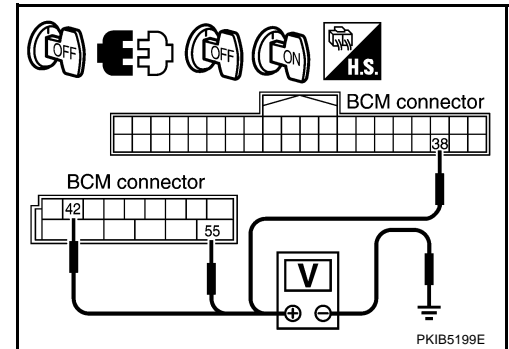

**OK or NG**

OK >> GO TO 3.

NG >> Check harness for open or short between fuse, fusible link and BCM.

## 3. CHECK GROUND CIRCUIT

Check continuity between BCM harness connector and ground.

Terminal		Ground	Continuity
Connector	Terminal (Wire color)		Yes
M35	52 (B)		Yes

**OK or NG**

OK >> INSPECTION END

NG >> Repair harness or connector.

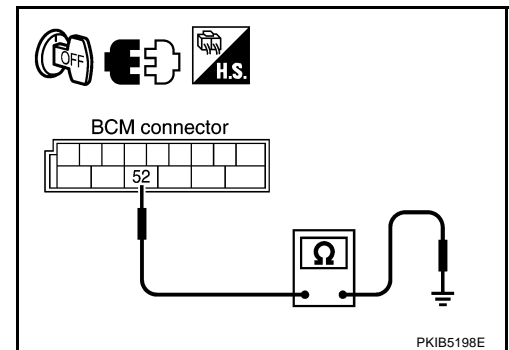



# FRONT WIPER AND WASHER SYSTEM

## CONSULT-II Functions (BCM)

AKS00AMW

CONSULT-II can display each diagnostic item using the diagnostic test modes shown following.

BCM diagnosis position	Diagnosis mode	Description
WIPER	WORK SUPPORT	Changes the setting for each function.
	DATA MONITOR	Displays BCM input data in real time.
	ACTIVE TEST	Device operation can be checked by applying a drive signal to device.
BCM	SELF-DIAG RESULTS	BCM performs self-diagnosis of CAN communication.
	CAN DIAG SUPPORT MNTR	The result of transmit/receive diagnosis of CAN communication can be read.

## CONSULT-II BASIC OPERATION

### CAUTION:

If CONSULT-II is used with no connection of CONSULT-II CONVERTER, malfunctions might be detected in self-diagnosis depending on control unit which carry out CAN communication.

1. With the ignition switch OFF, connect CONSULT-II and CONSULT-II CONVERTER to the data link connector, and then turn the ignition switch ON.

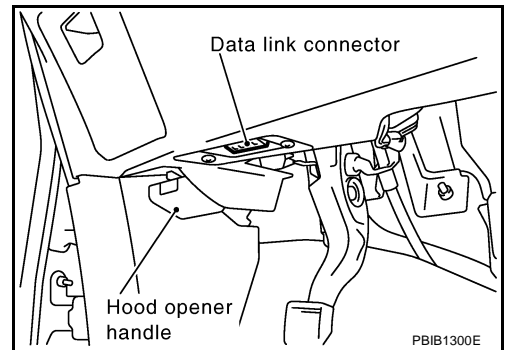

2. Touch "START (NISSAN BASED VHCL)".

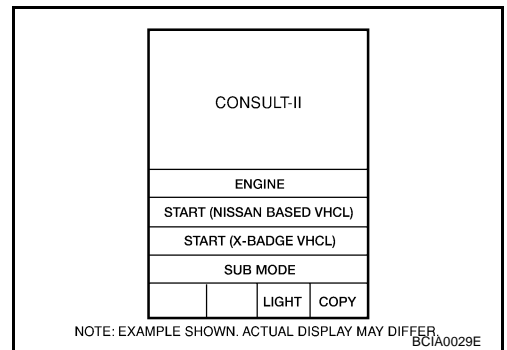

3. Touch "BCM" on "SELECT SYSTEM" screen.  
If "BCM" is not indicated, refer to [GI-39, "CONSULT-II Data Link Connector \(DLC\) Circuit"](#).

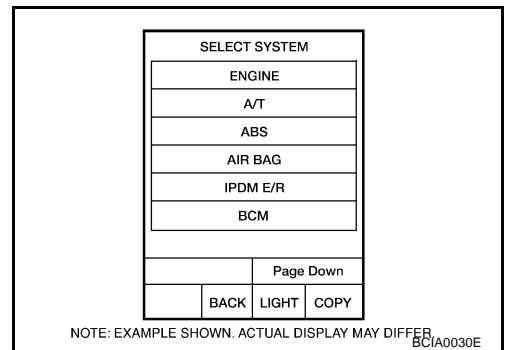

# FRONT WIPER AND WASHER SYSTEM

4. Touch "WIPER".

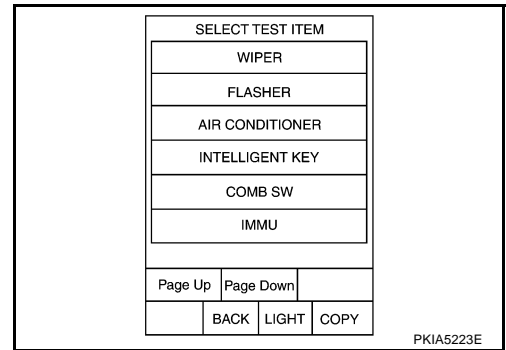

## WORK SUPPORT

### Operation Procedure

1. Touch "WIPER" on "SELECT TEST ITEM" screen.
2. Touch "WORK SUPPORT" on "SELECT DIAG MODE" screen.
3. Touch "WIPER SPEED SETTING" on "SELECT WORK ITEM" screen.
4. Touch "START".
5. Touch "CHANGE SETT".
6. The setting will be changed and "CUSTOMIZING COMPLETED" will be displayed.
7. Touch "END".

### Display Item List

Item	Description	CONSULT-II	Factory setting
WIPER SPEED SETTING	Vehicle speed sensing type wiper control mode can be changed in this mode. Selects vehicle speed sensing type wiper control mode between two ON/OFF.	ON	×
		OFF	—

## DATA MONITOR

### Operation Procedure

1. Touch "WIPER" on "SELECT TEST ITEM" screen.
2. Touch "DATA MONITOR" on "SELECT DIAG MODE" screen.
3. Touch either "ALL SIGNALS" or "SELECTION FROM MENU" on "SELECT MONITOR ITEM" screen.

ALL SIGNALS	Monitors all the signals.
SELECTION FROM MENU	Selects items and monitors them.

4. When "SELECTION FROM MENU" is selected, touched items to be monitored. If "ALL SIGNALS" is selected, all items will be monitored.
5. Touch "START".
6. Touch "RECORDING START" while monitoring to record the status of the item being monitored. To stop recording, touch "RECORDING STOP".

### Display Item List

Monitor item	Contents
IGN ON SW "ON/OFF"	Displays "ignition switch ON (ON)/Other OFF or ACC (OFF)" status as judged from ignition switch signal.
IGN SW CAN "ON/OFF"	Displays "ignition switch ON (ON)/Other OFF or ACC (OFF)" status as judged from CAN communication signal.
FR WIPER HI "ON/OFF"	Displays "FRONT WIPER HI (ON)/Other (OFF)" status as judged from wiper switch signal.
FR WIPER LOW "ON/OFF"	Displays "FRONT WIPER LOW (ON)/Other (OFF)" status as judged from wiper switch signal.
FR WIPER INT "ON/OFF"	Displays "FRONT WIPER INT (ON)/Other (OFF)" status as judged from wiper switch signal.
FR WASHER SW "ON/OFF"	Displays "FRONT WASHER Switch (ON)/Other (OFF)" status as judged from wiper switch signal.

# FRONT WIPER AND WASHER SYSTEM

Monitor item		Contents
INT VOLUME	"1 - 7"	Displays intermittent operation dial position setting (1 - 7) as judged from wiper switch signal.
FR WIPER STOP	"ON/OFF"	Displays "Stopped (ON)/Operating (OFF)" status as judged from the auto-stop signal.
VEHICLE SPEED	"km/h"	Displays vehicle speed status as judged from vehicle speed signal.
RR WIPER ON	"ON/OFF"	Displays "Rear Wiper ON (ON)/Other (OFF)" status as judged from wiper switch signal.
RR WIPER INT	"ON/OFF"	Displays "Rear Wiper INT (ON)/Other (OFF)" status as judged from wiper switch signal.
RR WASHER SW	"ON/OFF"	Displays "Rear Washer Switch (ON)/Other (OFF)" status as judged from wiper switch signal.
RR WIPER STOP	"ON/OFF"	Displays "Rear Wiper Stop (ON)/Other (OFF)" status, as judged from wiper switch signal.
RR WIPER STP2 <sup>NOTE</sup>	"OFF"	—

**NOTE:**

This item is displayed, but cannot be monitored.

## ACTIVE TEST

### Operation Procedure

1. Touch "WIPER" on the "SELECT TEST ITEM" screen.
2. Touch "ACTIVE TEST" on "SELECT DIAG MODE" screen.
3. Touch items to be tested, and check operation.
4. During operation check, touching "STOP" deactivates operation.

### Display Item List

Test item	Display on CONSULT-II screen	Description
Front wiper output	FR WIPER	With a certain operation (OFF, HI, LO, INT), the front wiper can be operated.
Rear wiper output	RR WIPER	Rear wiper can be operated by any ON-OFF operation.

A  
B  
C  
D  
E  
F  
G  
H  
I  
J  
L  
M



# FRONT WIPER AND WASHER SYSTEM

AKS00AMX

## CONSULT-II Functions (IPDM E/R)

CONSULT-II can display each diagnostic item using the diagnostic test modes shown following.

Diagnosis Mode	Description
SELF-DIAG RESULTS	Refer to <a href="#">PG-20. "SELF-DIAG RESULTS"</a> .
DATA MONITOR	The input/output data of IPDM E/R is displayed in real time.
CAN DIAG SUPPORT MNTR	The result of transmit/receive diagnosis of CAN communication can be read.
ACTIVE TEST	IPDM E/R sends a drive signal to electronic components to check their operation.

## CONSULT-II BASIC OPERATION

### CAUTION:

If CONSULT-II is used with no connection of CONSULT-II CONVERTER, malfunctions might be detected in self-diagnosis depending on control unit which carry out CAN communication.

1. With the ignition switch OFF, connect CONSULT-II and CONSULT-II CONVERTER to the data link connector, then turn the ignition switch ON.

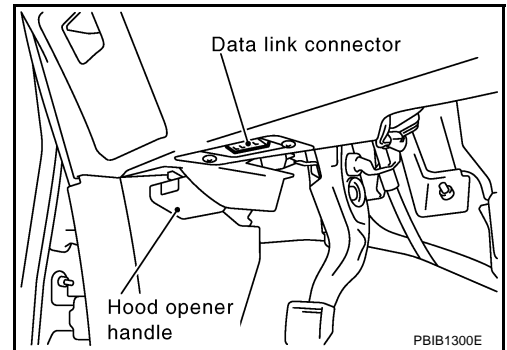

2. Touch "START (NISSAN BASED VHCL)".

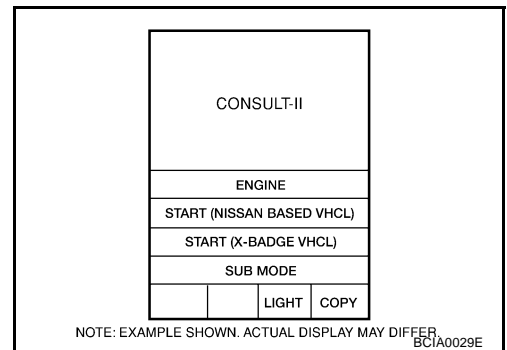

3. Touch "IPDM E/R" on "SELECT SYSTEM" screen. If "IPDM E/R" is not indicated, refer to [GI-39. "CONSULT-II Data Link Connector \(DLC\) Circuit"](#) .

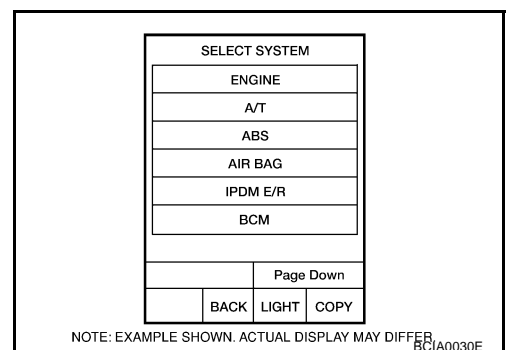

# FRONT WIPER AND WASHER SYSTEM

- Select the desired part to be diagnosed on the "SELECT DIAG MODE" screen.

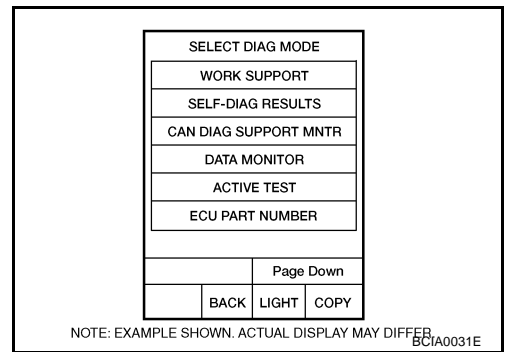

## DATA MONITOR

### Operation Procedure

- Touch "DATA MONITOR" on "SELECT DIAG MODE" screen.
- Touch "ALL SIGNALS", "MAIN SIGNALS", or "SELECTION FROM MENU" on the "SELECT MONITOR ITEM" screen.

ALL SIGNALS	Monitors all items.
MAIN SIGNALS	Monitor the predetermined item.
SELECTION FROM MENU	Selects items and monitors them.

- Touch the required monitoring item on "SELECTION FROM MENU". In "ALL SIGNALS", all items are monitored. In "MAIN SIGNALS", predetermined items are monitored.
- Touch "START".
- Touch "RECORD" while monitoring to record the status of the item being monitored. To stop recording, touch "STOP".

### All Signals, Main Signals, Selection From Menu

Item name	CONSULT-II screen display	Display or unit	Monitor item selection			Description
			ALL SIGNALS	MAIN SIGNALS	SELECTION FROM MENU	
FR wiper request	FR WIP REQ	STOP/LOW/HI	×	×	×	Signal status input from BCM
Wiper auto stop	WIP AUTO STOP	ACT P/STOP P	×	×	×	Output status of IPDM E/R
Wiper protection	WIP PROT	OFF/BLOCK	×	×	×	Control status of IPDM E/R

#### NOTE:

Perform monitoring of IPDM E/R data with the ignition switch ON. When the ignition switch is at ACC, the display may not be correct.

## ACTIVE TEST

### Operation Procedure

- Touch "ACTIVE TEST" on "SELECT DIAG MODE" screen.
- Touch item to be tested, and check operation.
- Touch "START".
- Touch "STOP" while testing to stop the operation.

Test item	CONSULT-II screen display	Description
Front wiper (HI, LO) output	FRONT WIPER	With a certain operation (OFF, HI ON, LO ON), the front wiper relay (Lo, Hi) can be operated.

# FRONT WIPER AND WASHER SYSTEM

AKS00CRK

## Front Wiper Does Not Operate

### CAUTION:

- During IPDM E/R fail-safe control, front wipers may not operate. Refer to [PG-17, "CAN COMMUNICATION LINE CONTROL"](#) in "PG IPDM E/R" to make sure that it is not in fail-safe status.

## 1. ACTIVE TEST

With CONSULT-II

- Select "IPDM E/R" by CONSULT-II, and select "ACTIVE TEST" on "SELECT DIAG MODE" screen.
- Select "FRONT WIPER" on "SELECT TEST ITEM" screen.
- Touch "LO" or "HI" screen.

Without CONSULT-II

Start up auto active test. Refer to [PG-23, "Auto Active Test"](#).

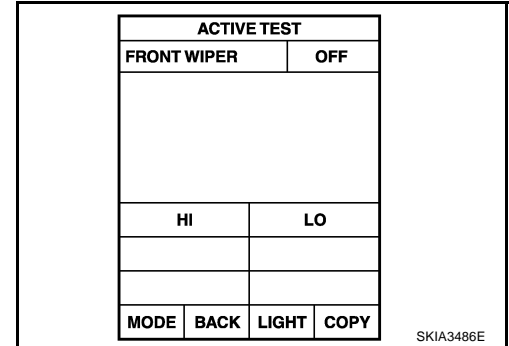

Does front wiper operate normally?

YES >> GO TO 5.

NO >> GO TO 2.

## 2. CHECK FRONT WIPER CIRCUIT

- Turn ignition switch OFF.
- Disconnect IPDM E/R connector and front wiper motor connector.
- Check continuity between IPDM E/R harness connector and front wiper motor harness connector terminal.

Terminal				Continuity
IPDM E/R		Front wiper motor		
Connector	Terminal (Wire color)	Connector	Terminal (Wire color)	
E7	21 (L)	E22	3 (L)	Yes
	31 (L/B)		2 (L/B)	

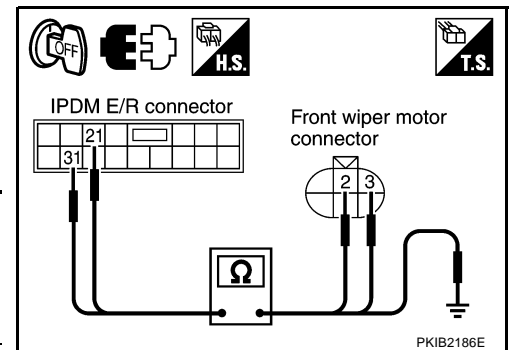

- Check continuity between IPDM E/R harness connector terminal and Ground.

Terminal			Continuity
IPDM E/R		Ground	
Connector	Terminal (Wire color)		
E7	21 (L)	No	
	31 (L/B)		

OK or NG

OK >> GO TO 3.

NG >> Repair harness or connector.

# FRONT WIPER AND WASHER SYSTEM

## 3. CHECK GROUND CIRCUIT

Check continuity between front wiper motor harness connector E22 terminal 1 (B) and ground.

**1 (B) – Ground : Continuity should exist.**

OK or NG

- OK >> GO TO 4.
- NG >> Repair harness or connector.

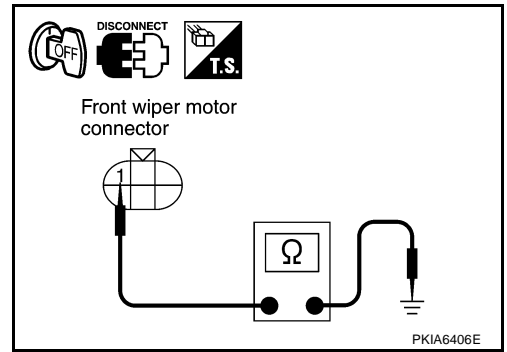

## 4. CHECK IPDM E/R

With CONSULT-II

1. Connect IPDM E/R connector and front wiper motor connector.
2. Select "IPDM E/R" by CONSULT-II, and select "ACTIVE TEST" on "SELECT DIAG MODE" screen.
3. Select "FRONT WIPER" on "SELECT TEST ITEM" screen.
4. Touch "LO" or "HI" screen.
5. Check voltage between IPDM E/R harness connector and ground while front wiper (HI, LO) is operating.

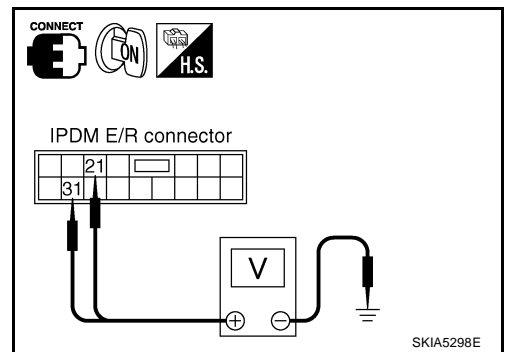

Terminal		Condition	Voltage
IPDM E/R (+)			
Connector	Terminal (Wire color)	(-)	
E7	21 (L)	Stopped	Approx. 0V
		LO operation	Battery voltage
	31 (L/B)	Stopped	Approx. 0V
		HI operation	Battery voltage

Without CONSULT-II

1. Connect IPDM E/R connector and front wiper motor connector.
2. Start up auto active test. Refer to [PG-23, "Auto Active Test"](#).
3. Check voltage between IPDM E/R harness connector and ground while front wiper (HI, LO) is operating.

Terminal		Condition	Voltage
IPDM E/R (+)			
Connector	Terminal (Wire color)	(-)	
E7	21 (L)	Stopped	Approx. 0V
		LO operation	Battery voltage
	31 (L/B)	Stopped	Approx. 0V
		HI operation	Battery voltage

OK or NG

- OK >> Replace front wiper motor.
- NG >> Replace IPDM E/R.

A  
B  
C  
D  
E  
F  
G  
H  
I  
J  
K  
L  
M

WW

# FRONT WIPER AND WASHER SYSTEM

## 5. CHECK CIRCUIT BETWEEN COMBINATION SWITCH AND BCM

☑ With CONSULT-II

1. Select "BCM" on CONSULT-II, and select "WIPER" on "SELECT TEST ITEM" screen.
2. Select "DATA MONITOR" on "SELECT DIAG MODE" screen. Make sure that "FR WIPER INT", "FR WIPER LOW", and "FR WIPER HI" turn ON-OFF according to wiper switch operation.

☒ Without CONSULT-II

Refer to [LT-145, "Combination Switch Inspection"](#).

OK or NG

OK >> GO TO 6.

NG >> Check combination switch (wiper switch). Refer to [LT-145, "Combination Switch Inspection"](#).

DATA MONITOR			
MONITOR			
IGN ON SW	ON		
IGN SW CAN	ON		
FR WIPER HI	OFF		
FR WIPER LOW	OFF		
FR WIPER INT	OFF		
FR WASHER SW	OFF		
INT VOLUME	7		
FR WIPER STOP	ON		
VEHICLE SPEED	0.0 km/h		
		Page Down	
		RECORD	
MODE	BACK	LIGHT	COPE

PKIB0110E

## 6. CHECK CIRCUIT BETWEEN IPDM E/R AND BCM

Select "BCM" on CONSULT-II, and perform self-diagnosis for "BCM".

Displayed self-diagnosis results

NO DTC>>Replace BCM. Refer to [BCS-16, "Removal and Installation of BCM"](#).

CAN COMM CIRCUIT>>Check CAN communication line of BCM. Refer to [BCS-15, "CAN Communication Inspection Using CONSULT-II \(Self-Diagnosis\)"](#).

SELF-DIAG RESULTS			
DTC RESULTS		TIME	
CAN COMM CIRCUIT [U1000]			
ERASE		PRINT	
MODE	BACK	LIGHT	COPY

PKIA7627E

## Front Wiper Does Not Return to Stop Position

### 1. CHECK FRONT WIPER STOP SIGNAL

☑ With CONSULT-II

Select "IPDM E/R" on CONSULT-II. With "DATA MONITOR", make sure that "WIP AUTO STOP" turns "ACT P" - "STOP P" linked with wiper operation.

☒ Without CONSULT-II

GO TO 2.

OK or NG

OK >> Replace IPDM E/R.

NG >> GO TO 2.

DATA MONITOR			
MONITOR			
WIP AUTO STOP	STOP P		
		RECORD	
MODE	BACK	LIGHT	COPY

PKIA7614E

### 2. CHECK IPDM E/R

1. Turn ignition switch OFF.
2. Disconnect front wiper motor connector.
3. Turn ignition switch ON.
4. Check voltage between front wiper harness connector E22 terminal 4 (L/Y) and Ground.

**4 (L/Y) – Ground : Battery voltage.**

OK or NG

OK >> GO TO 4.

NG >> GO TO 3.

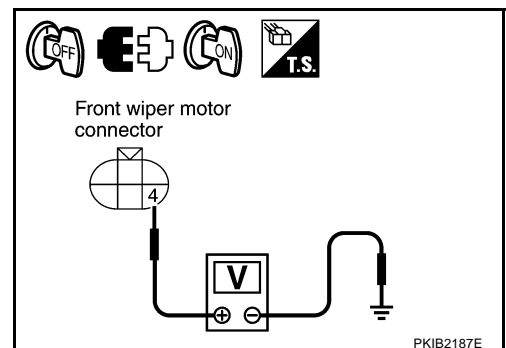



# FRONT WIPER AND WASHER SYSTEM

## 3. CHECK FRONT WIPER AUTO STOP CIRCUIT

1. Turn ignition switch OFF.
2. Disconnect IPDM E/R connector.
3. Check continuity between IPDM E/R harness connector E7 terminal 32 (L/Y) and front wiper motor harness connector E22 terminal 4 (L/Y).

**32 (L/Y) – 4 (L/Y) : Continuity should exist.**

4. Check continuity between IPDM E/R harness connector E7 terminal 32(L/Y) and Ground.

**32 (L/Y) – Ground : Continuity should not exist.**

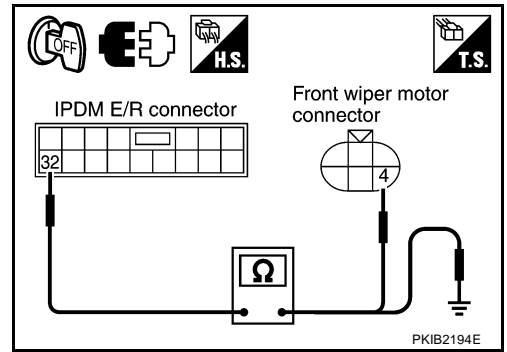

OK or NG

- OK >> Replace IPDM E/R.  
 NG >> Repair harness or connector.

## 4. CHECK IPDM E/R

1. Connect IPDM E/R connector and front wiper motor connector.
2. Turn ignition switch ON.
3. Check voltage between IPDM E/R harness connector and ground while front wiper motor is stopped and while it is operating.

Terminal		Condition	Voltage	
IPDM E/R (+)				
Connector	Terminal (Wire color)	(-)		
E7	32 (L/Y)	Ground	Wiper stopped	Approx. 0V
			Wiper operating	Battery voltage

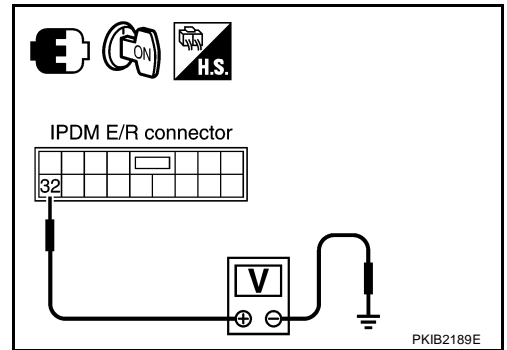

OK or NG

- OK >> Replace IPDM E/R.  
 NG >> Replace front wiper motor.

## Only Front Wiper Low Does Not Operate

### 1. ACTIVE TEST

Ⓜ With CONSULT-II

1. Select "IPDM E/R" by CONSULT-II, and select "ACTIVE TEST" on "SELECT DIAG MODE" screen.
2. Select "FRONT WIPER" on "SELECT TEST ITEM" screen.
3. Touch "LO" screen.

ⓧ Without CONSULT-II

Start up auto active test. Refer to [PG-23, "Auto Active Test"](#).

Does front wiper operate normally?

- YES >> Refer to [LT-145, "Combination Switch Inspection"](#).  
 NO >> GO TO 2.

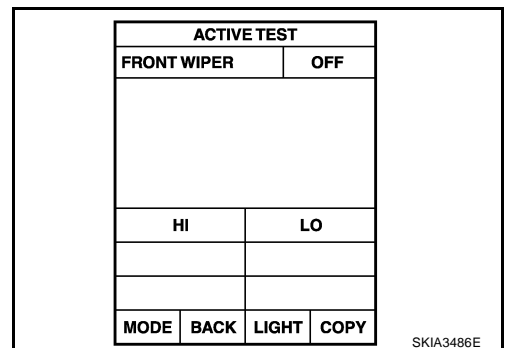

# FRONT WIPER AND WASHER SYSTEM

## 2. CHECK FRONT WIPER MOTOR CIRCUIT

1. Turn ignition switch OFF.
2. Disconnect IPDM E/R connector and front wiper motor connector.
3. Check continuity between IPDM E/R harness connector E7 terminal 21 (L) and front wiper motor harness E22 connector terminal 3 (L).

**21 (L) – 3 (L) : Continuity should exist.**

4. Check continuity between IPDM E/R harness connector E7 terminal 21 (L) and ground.

**21 (L) – Ground : Continuity should not exist.**

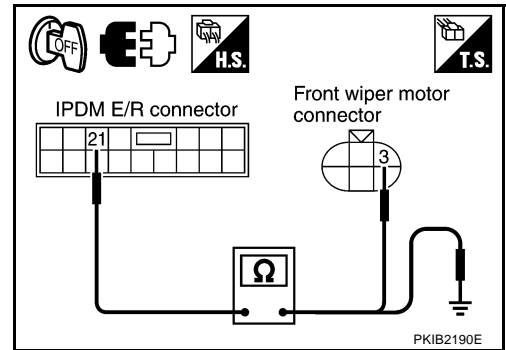

OK or NG

OK >> GO TO 3.

NG >> Repair harness or connector.

## 3. CHECK IPDM E/R

With CONSULT-II

1. Connect IPDM E/R connector and front wiper motor connector.
2. Select "IPDM E/R" by CONSULT-II, and select "ACTIVE TEST" on "SELECT DIAG MODE" screen.
3. Select "FRONT WIPER" on "SELECT TEST ITEM" screen.
4. Touch "LO" screen.
5. Check voltage between IPDM E/R harness connector E7 terminal 21 (L) and ground while front wiper LO is operating.

**21 (L) – Ground : Battery voltage.**

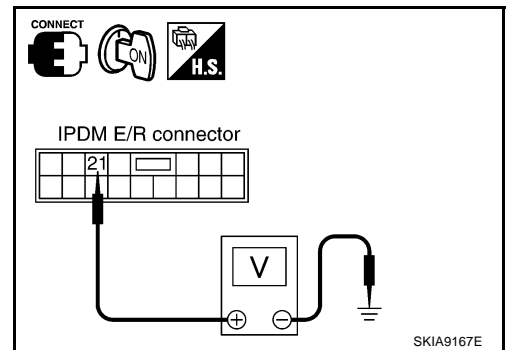

Without CONSULT-II

1. Connect IPDM E/R connector and front wiper motor connector.
2. Start up auto active test. Refer to [PG-23, "Auto Active Test"](#).
3. Check voltage between IPDM E/R harness connector E7 terminal 21 (L) and ground while front wiper LO is operating.

**21 (L) – Ground : Battery voltage.**

OK or NG

OK >> Replace front wiper motor.

NG >> Replace IPDM E/R.

## Only Front Wiper Hi Does Not Operate

AKS00CRN

### 1. ACTIVE TEST

With CONSULT-II

1. Select "IPDM E/R" by CONSULT-II, and select "ACTIVE TEST" on "SELECT DIAG MODE" screen.
2. Select "FRONT WIPER" on "SELECT TEST ITEM" screen.
3. Touch "HI" screen.

Without CONSULT-II

Start up auto active test. Refer to [PG-23, "Auto Active Test"](#)

Does front wiper operate normally?

YES >> Refer to [LT-145, "Combination Switch Inspection"](#).

NO >> GO TO 2.

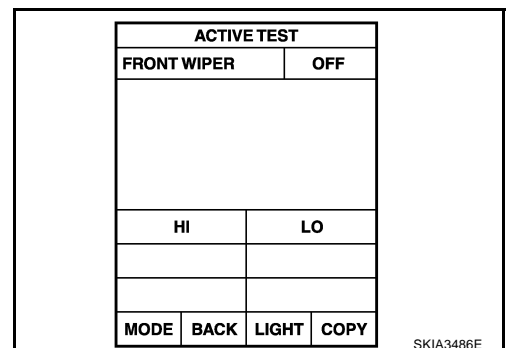

# FRONT WIPER AND WASHER SYSTEM

## 2. CHECK FRONT WIPER MOTOR CIRCUIT

1. Turn ignition switch OFF.
2. Disconnect IPDM E/R connector and front wiper motor connector.
3. Check continuity between IPDM E/R harness connector E7 terminal 31 (L/B) and front wiper motor harness E22 connector terminal 2 (L/B).

**31 (L/B) – 2 (L/B) : Continuity should exist.**

4. Check continuity between IPDM E/R harness connector E7 terminal 31(L/B) and ground.

**31 (L/B) – Ground : Continuity should not exist.**

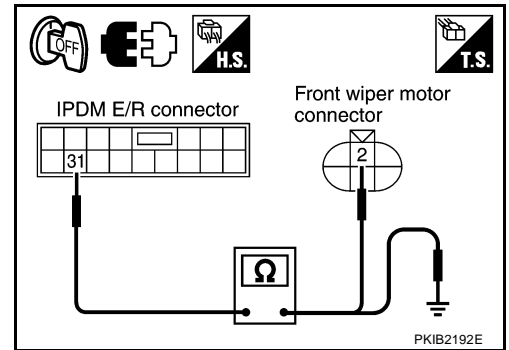

OK or NG

OK >> GO TO 3.

NG >> Repair harness or connector.

## 3. CHECK IPDM E/R

Ⓜ With CONSULT-II

1. Connect IPDM E/R connector and front wiper motor connector.
2. Select "IPDM E/R" by CONSULT-II, and select "ACTIVE TEST" on "SELECT DIAG MODE" screen.
3. Select "FRONT WIPER" on "SELECT TEST ITEM" screen.
4. Touch "HI" screen.
5. Check voltage between IPDM E/R harness connector E7 terminal 31 (L/B) and ground while front wiper HI is operating.

**31 (L/B) - Ground : Battery voltage.**

⊗ Without CONSULT-II

1. Connect IPDM E/R connector and front wiper motor connector.
2. Start up auto active test. Refer to [PG-23, "Auto Active Test"](#).
3. Check voltage between IPDM E/R harness connector E7 terminal 31 (L/B) and ground while front wiper HI is operating.

**31 (L/B) - Ground : Battery voltage.**

OK or NG

OK >> Replace front wiper motor.

NG >> Replace IPDM E/R.

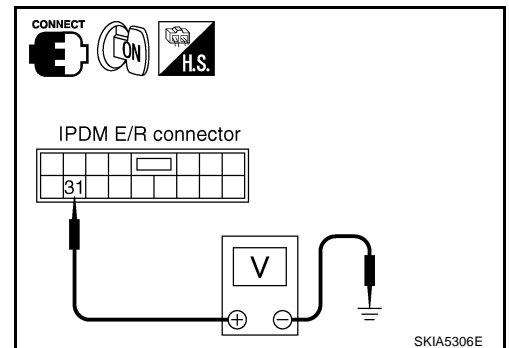

A  
B  
C  
D  
E  
F  
G  
H  
I  
J  
L  
M

WW

# FRONT WIPER AND WASHER SYSTEM

AKS00CRO

## Only Front Wiper Intermittent Does Not Operate

### 1. CHECK COMBINATION SWITCH

☑ With CONSULT-II

1. Select "BCM" on CONSULT-II, and select "WIPER" on "SELECT TEST ITEM" screen.
2. Select "DATA MONITOR" on "SELECT DIAG MODE" screen. Make sure that "FR WIPER INT", turn ON-OFF according to wiper switch operation.

DATA MONITOR			
MONITOR			
IGN ON SW	ON		
IGN SW CAN	ON		
FR WIPER HI	OFF		
FR WIPER LOW	OFF		
FR WIPER INT	OFF		
FR WASHER SW	OFF		
INT VOLUME	7		
FR WIPER STOP	ON		
VEHICLE SPEED	0.0 km/h		
		Page Down	
		RECORD	
MODE	BACK	LIGHT	COPE

PKIB0110E

☒ Without CONSULT-II

Refer to [LT-145, "Combination Switch Inspection"](#) .

OK or NG

OK >> Replace BCM. Refer to [BCS-16, "Removal and Installation of BCM"](#) .

NG >> Check combination switch (wiper switch) Refer to [LT-145, "Combination Switch Inspection"](#) .

## Front Wiper Interval Time Is Not Controlled by Vehicle Speed

AKS00CRP

### 1. CHECK FUNCTION OF COMBINATION METER

Confirm that speedometer operates normally.

Does front wiper operate normally?

YES >> GO TO 2.

NO >> Combination meter vehicle speed system malfunction. Refer to [DI-19, "Vehicle Speed Signal Inspection"](#) .

### 2. CHECK CAN COMMUNICATION BETWEEN BCM AND COMBINATION METER

Select "BCM" on CONSULT-II, and perform self-diagnosis for "BCM".

Displayed self-diagnosis results

NO DTC>>Replace BCM. Refer to [BCS-16, "Removal and Installation of BCM"](#) .

CAN COMM CIRCUIT>>Check CAN communication line of BCM. Refer to [BCS-15, "CAN Communication Inspection Using CONSULT-II \(Self-Diagnosis\)"](#) .

SELF-DIAG RESULTS			
DTC RESULTS		TIME	
CAN COMM CIRCUIT [U1000]			
ERASE		PRINT	
MODE	BACK	LIGHT	COPY

PKIA7627E

## Front Wiper Intermittent Operation Switch Position Cannot Be Adjusted

AKS00CRO

### 1. CHECK CIRCUIT BETWEEN COMBINATION SWITCH AND BCM

☑ With CONSULT-II

1. Select "BCM" on CONSULT-II, and select "WIPER" on "SELECT TEST ITEM" screen.
2. Select "DATA MONITOR" on "SELECT DIAG MODE" screen. Make sure that "INT VOLUME", changes in order form 1 to 7 according to wiper switch operation.

DATA MONITOR			
MONITOR			
IGN ON SW	ON		
IGN SW CAN	ON		
FR WIPER HI	OFF		
FR WIPER LOW	OFF		
FR WIPER INT	OFF		
FR WASHER SW	OFF		
INT VOLUME	7		
FR WIPER STOP	ON		
VEHICLE SPEED	0.0 km/h		
		Page Down	
		RECORD	
MODE	BACK	LIGHT	COPE

PKIB0110E

☒ Without CONSULT-II

Refer to [LT-145, "Combination Switch Inspection"](#) .

OK or NG

OK >> Replace BCM. Refer to [BCS-16, "Removal and Installation of BCM"](#) .

NG >> Check combination switch (wiper switch). Refer to [LT-145, "Combination Switch Inspection"](#) .

# FRONT WIPER AND WASHER SYSTEM

## Wiper Does Not Wipe When Front Washer Operates

AKS00CRR

### 1. CHECK CIRCUIT BETWEEN COMBINATION SWITCH AND BCM

① With CONSULT-II

1. Select "BCM" on CONSULT-II, and select "WIPER" on "SELECT TEST ITEM" screen.
2. Select "DATA MONITOR" on "SELECT DIAG MODE" screen. Make sure that "FR WASHER SW" turn ON-OFF according to front wiper switch operation.

② Without CONSULT-II

Refer to [LT-145, "Combination Switch Inspection"](#).

OK or NG

- OK >> Replace BCM Refer to [BCS-16, "Removal and Installation of BCM"](#).
- NG >> Check front wiper switch. Refer to [LT-145, "Combination Switch Inspection"](#).

DATA MONITOR			
MONITOR			
IGN ON SW	ON		
IGN SW CAN	ON		
FR WIPER HI	OFF		
FR WIPER LOW	OFF		
FR WIPER INT	OFF		
FR WASHER SW	OFF		
INT VOLUME	7		
FR WIPER STOP	ON		
VEHICLE SPEED	0.0 km/h		
Page Down			
RECORD			
MODE	BACK	LIGHT	COPE

PKIB0110E

A

B

C

D

E

F

G

H

I

J

WW

L

M

# FRONT WIPER AND WASHER SYSTEM

**After Front Wiper Operate for 10 Seconds, They Stop for 20 Seconds, and After Repeating the Operations Five Times, They Become Inoperative**

AKS00CRS

## CAUTION:

- When auto-stop signal has not varied for 10 seconds or longer while IPDM E/R is operating front wipers, IPDM E/R considers that front wipers are locked, and stops wiper output. That causes this symptom.
- This status can be checked by “DATA MONITOR” of “IPDM E/R” on which “WIPER PROTECTION” item shows “BLOCK”.

## 1. CHECK WIPER MOTOR SIGNAL

④ With CONSULT-II

Select “IPDM E/R” by CONSULT-II. With “DATA MONITOR”, make sure that “WIP AUTO STOP” turns “ACT P” - “STOP P” linked with wiper operation.

⊗ Without CONSULT-II

GO TO 2.

OK or NG

OK >> Replace IPDM E/R.

NG >> GO TO 2.

DATA MONITOR			
MONITOR			
WIP AUTO STOP		STOP P	
		RECORD	
MODE	BACK	LIGHT	COPY

PKIA7614E

## 2. CHECK WIPER AUTO STOP CIRCUIT

1. Turn ignition switch OFF.
2. Disconnect IPDM E/R connector and front wiper motor connector.
3. Check continuity between IPDM E/R harness connector E7 terminal 32 (L/Y) and front wiper motor harness connector E22 terminal 4 (L/Y).

**32 (L/Y) - 4 (L/Y) : Continuity should exist.**

4. Check continuity between IPDM E/R harness connector E7 terminal 32 (L/Y) and ground.

**32 (L/Y) - Ground : Continuity should not exist.**

OK or NG

OK >> GO TO 3.

NG >> Repair harness or connector.

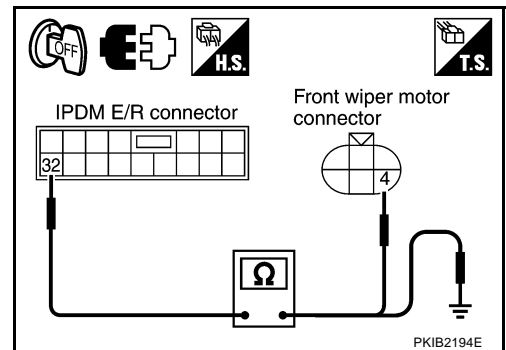

# FRONT WIPER AND WASHER SYSTEM

## 3. CHECK FRONT WIPER MOTOR

1. Connect IPDM E/R connector and front wiper connector.
2. Turn ignition switch ON.
3. Check voltage between IPDM E/R harness connector E7 terminal 32 (L/Y) and ground while front wiper motor is stopped and while it is operating.

Terminal		(-)	Condition	Voltage
IPDM E/R (+)				
Connector	Terminal (Wire color)			
E7	32 (L/Y)	Ground	Wiper stopped	Approx. 0V
			Wiper operating	Battery voltage

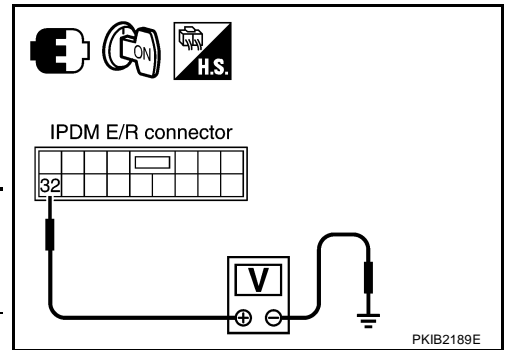

OK or NG

- OK >> Replace IPDM E/R.  
 NG >> Replace front wiper motor.

## Front Wiper Does Not Stop

AKS00CRT

### 1. CHECK CIRCUIT BETWEEN COMBINATION SWITCH AND BCM

With CONSULT-II

1. Select "BCM" on CONSULT-II, and select "WIPER" on "SELECT TEST ITEM" screen.
2. Select "DATA MONITOR" on "SELECT DIAG MODE" screen. Make sure that "FR WIPER INT", "FR WIPER LOW", "FR WIPER HI", and "FR WASHER SW" turn ON-OFF according to front wiper switch operation.

Without CONSULT-II

Refer to [LT-145, "Combination Switch Inspection"](#) .

OK or NG

- OK >> Replace IPDM E/R.  
 NG >> Check combination switch (wiper switch). Refer to [LT-145, "Combination Switch Inspection"](#) .

DATA MONITOR	
MONITOR	
IGN ON SW	ON
IGN SW CAN	ON
FR WIPER HI	OFF
FR WIPER LOW	OFF
FR WIPER INT	OFF
FR WASHER SW	OFF
INT VOLUME	7
FR WIPER STOP	ON
VEHICLE SPEED	0.0 km/h
Page Down	
RECORD	
MODE	BACK
LIGHT	COPE

PKIB0110E

A  
B  
C  
D  
E  
F  
G  
H  
I  
J  
L  
M

WW

# FRONT WIPER AND WASHER SYSTEM

## Removal and Installation of Front Wiper Arms, Adjustment of Wiper Arms Stop Location

AKS00AN8

### REMOVAL

1. Operate wiper motor, and stop it at the auto stop position.
2. Remove wiper arm caps and mounting nuts, and remove wiper arms from vehicle.

### INSTALLATION

1. Clean up the pivot area as illustrated. This will reduce possibility of wiper arm looseness.

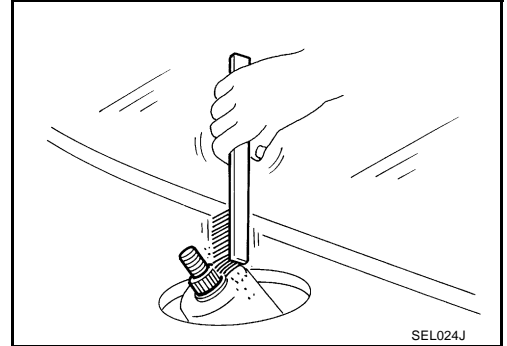

2. Prior to wiper arm installation, turn on wiper switch to operate wiper motor and then turn it "OFF" (auto stop).
3. Push wiper arm onto pivot shaft, paying attention to blind spline.
4. Lift the blade up and then set it down onto glass surface to set the blade center to clearance "L1" & "L2" immediately before tightening nut.
5. Eject washer fluid. Turn on wiper switch to operate wiper motor and then turn it "OFF".
6. Ensure that wiper blades stop within clearance "L1" & "L2".

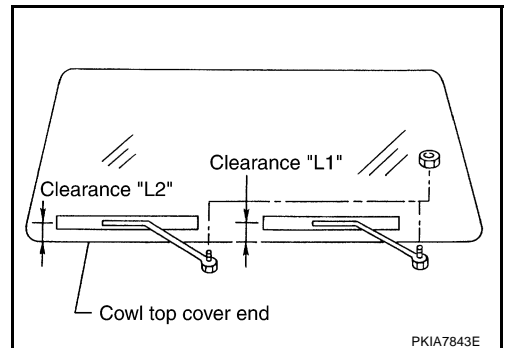

**Clearance "L1" : 38.2 – 53.2 mm (1.504 – 2.094 in)**

**Clearance "L2" : 49.6 – 64.6 mm (1.953 – 2.543 in)**

- Tighten wiper arm nuts to specified torque.

**Front wiper arm nuts  : 23.5 N·m (2.4 kg·m, 17 ft·lb)**

7. Attach wiper arm caps.

### ADJUSTMENT

Refer to [WW-32, "INSTALLATION"](#) .

## Removal and Installation of Front Wiper Motor and Linkage

AKS00AN9

### REMOVAL

1. Remove wiper arms. Refer to [WW-32, "REMOVAL"](#) .
2. Remove cowl top cover. Refer to [EI-21, "COWL TOP"](#) in "EI" section.
3. Remove washer tube.
4. Disconnect wiper motor connector.
5. Remove wiper motor and linkage mounting bolts, and remove wiper motor and linkage.

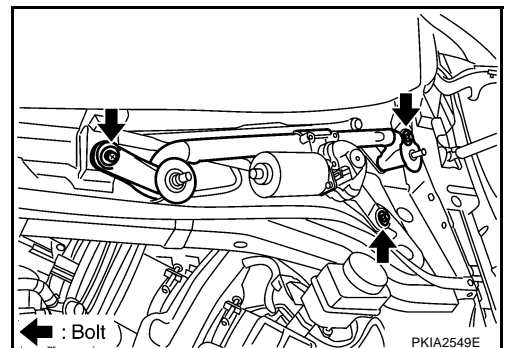



# FRONT WIPER AND WASHER SYSTEM

## INSTALLATION

1. Install wiper motor and linkage to the vehicle.
2. Connect wiper motor assembly to the connector. Turn wiper switch ON to operate wiper motor, then turn wiper switch OFF (auto stop).
3. Attach washer tube to washer tube joint.
4. Install cowl top cover. Refer to [EI-21, "COWL TOP"](#) in "EI" section.
5. Install wiper arms. Refer to [WW-32, "Removal and Installation of Front Wiper Arms, Adjustment of Wiper Arms Stop Location"](#)

**Wiper motor and linkage mounting bolts**  : 4.5 N·m (0.46 kg·m, 40 in-lb)

### CAUTION:

- Never drop the wiper motor or cause it to contact other parts.
- Check grease conditions of the motor arm and wiper link joint (at retainer side). Apply grease if necessary.

## Disassembly and Assembly of Front Wiper Motor and Linkage

AKS00ANA

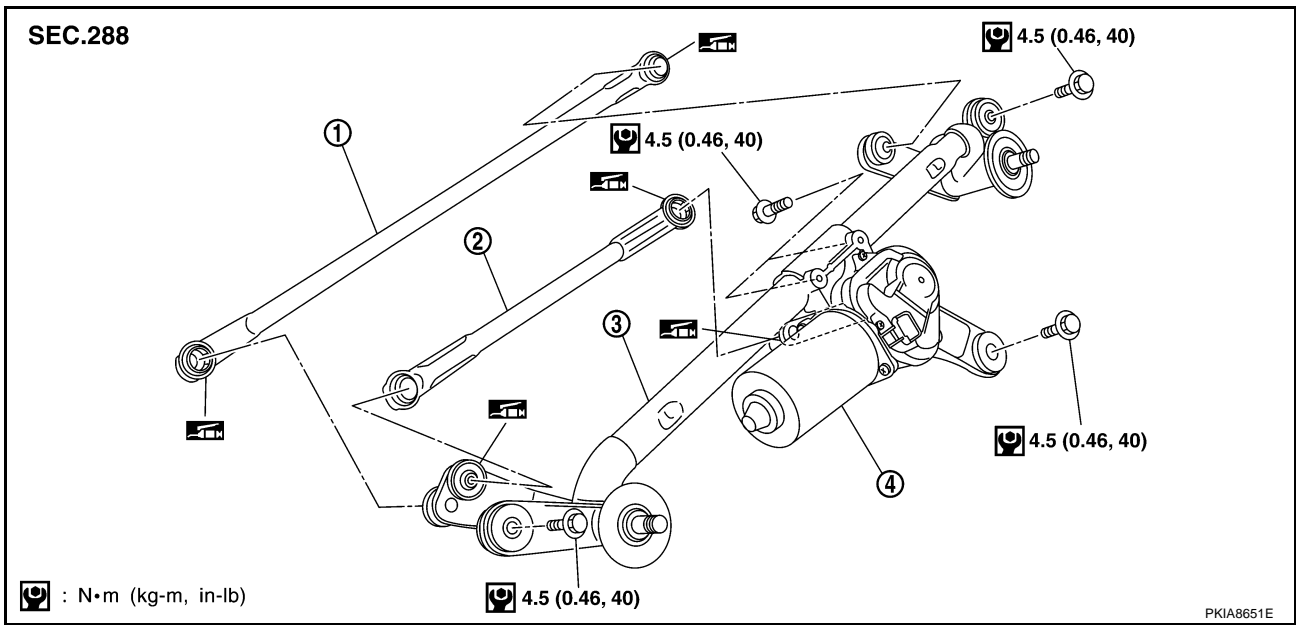

1. Wiper link 1
4. Wiper motor

2. Wiper link 2

3. Wiper frame

## DISASSEMBLY

1. Remove wiper link from wiper frame and the motor arm.
2. Remove wiper motor mounting bolts, and remove wiper motor from wiper frame.

## ASSEMBLY

Assembly is the reverse order of disassembly.

**Wiper motor mounting bolts**  : 4.5 N·m (0.46 kg·m, 40 in-lb)

# FRONT WIPER AND WASHER SYSTEM

AKS00ANB

## Washer Nozzle Adjustment

- In this model, the washer nozzle has a non-adjustment nozzle and requires no adjusting.
- If necessary, ensure that washer fluid spray covers at least the area as shown in the figure. (See the illustration)
- If the above is not satisfied, confirm that the washer nozzle is installed correctly on the cowl top cover and/or cowl top cover is installed correctly on the body.
- If they are installed correctly, and the fluid is still spraying out of the shooting target areas, replace them with new washer nozzle and/or cowl top cover.

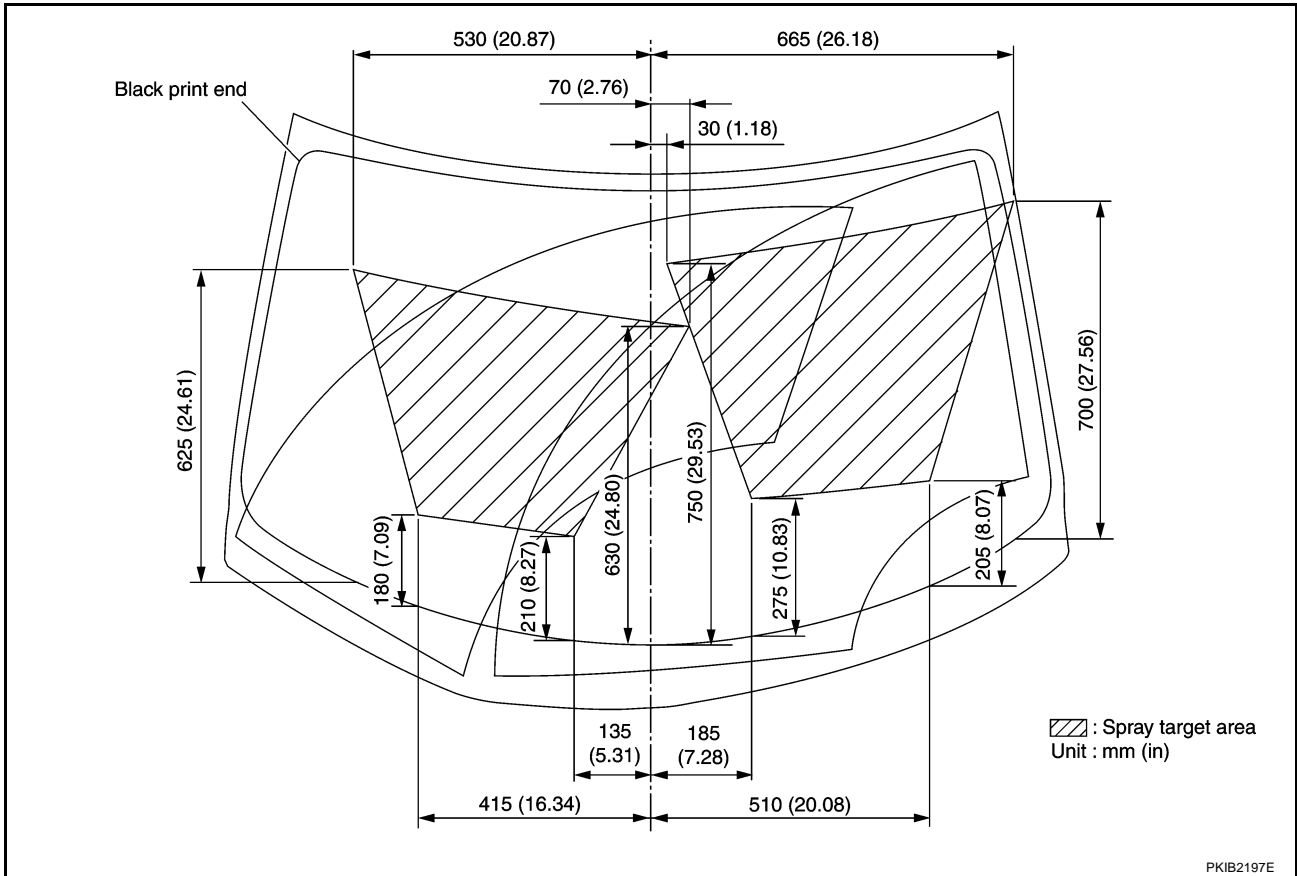

### CAUTION:

Never adjust the washer nozzle with needle pin. If attempts are made to adjust the washer nozzle with needle pin, damage may occur.

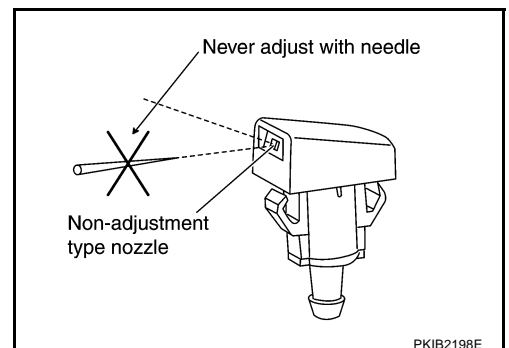

# FRONT WIPER AND WASHER SYSTEM

## Washer Tube Layout

AKS00ANC

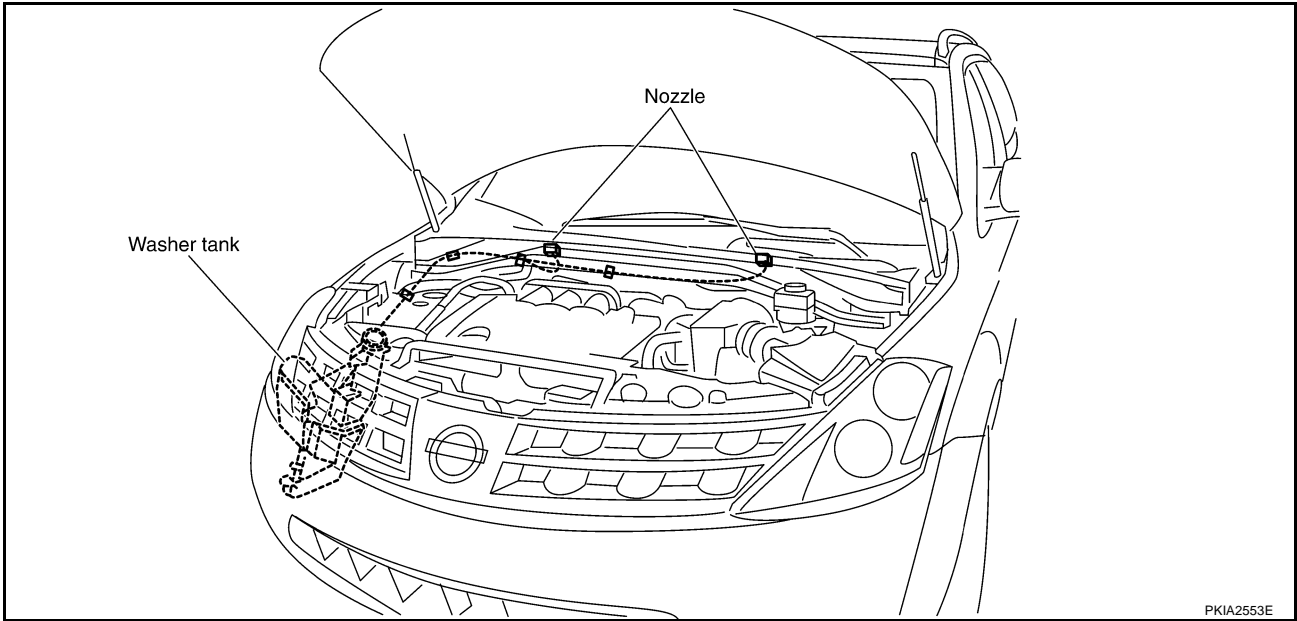

## Removal and Installation of Front Washer Nozzle

AKS00AND

1. Push the Washer nozzle in direction by the arrow as shown in the figure and remove it.
2. Remove washer tube.

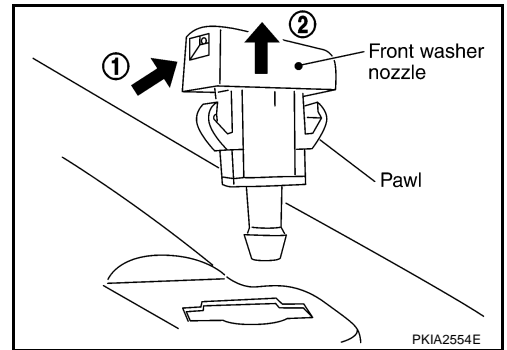

## INSTALLATION

Installation is the reverse order of removal.

## Inspection for Washer Nozzle

### CHECK VALVE INSPECTION

AKS00ANE

Blow air in the injection direction, and make sure air flows only one way. Make sure that the reverse direction (inhale) is not possible.

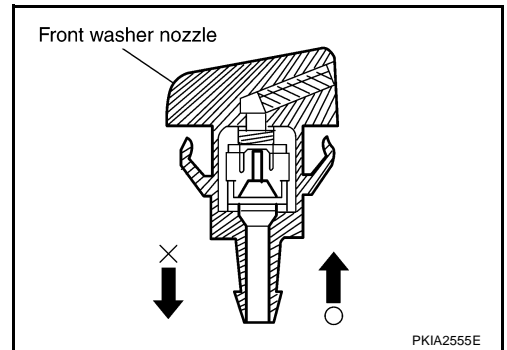

A  
B  
C  
D  
E  
F  
G  
H  
I  
J  
K  
L  
M

WW

# FRONT WIPER AND WASHER SYSTEM

## Removal and Installation of Front Wiper and Washer Switch

AKS00ANF

### REMOVAL

1. Remove instrument driver lower panel, steering column lower cover and combination meter. Refer to [IP-10, "INSTRUMENT PANEL ASSEMBLY"](#) in "EI" section.
2. Disconnect wiper and washer switch connector.
3. Pull wiper and washer switch toward the passenger door while pressing pawls in direction shown by the arrow in the figure, and remove it from the base.

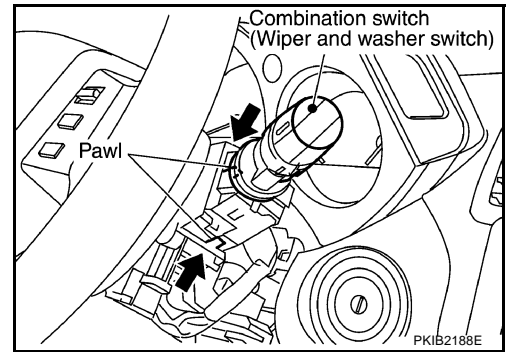

### INSTALLATION

Installation is the reverse order of removal.

## Removal and Installation of Washer Tank

AKS00ANG

### REMOVAL

1. Remove the washer tank inlet mounting bolt.

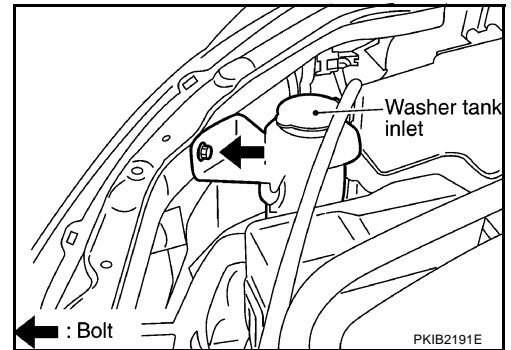

2. Remove fender protector (front). Refer to [EI-22, "FENDER PROTECTOR"](#) in "EI" section.
3. Remove front bumper. Refer to [EI-14, "FRONT BUMPER"](#) in "EI" section.
4. Disconnect washer pump connector.
5. Remove washer tank mounting bolt.
6. Remove washer tube, and remove washer tank from the vehicle.

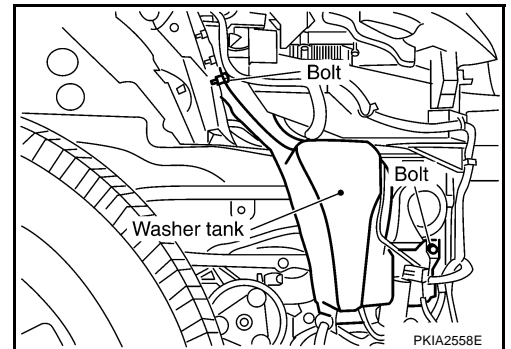

### INSTALLATION

Installation is the reverse order of removal.

### CAUTION:

After installation, add water up to the upper level of the washer tank inlet, and check for water leaks.

**Washer tank mounting bolt**  : 4.5 N·m (0.46 kg·m, 40 in·lb)

# FRONT WIPER AND WASHER SYSTEM

## Removal and Installation of Washer Pump

AKS00ANH

### REMOVAL

1. Remove fender protector (front). Refer to [EI-22, "FENDER PROTECTOR"](#) in "EI" section.
2. Remove the right side of front bumper. Refer to [EI-14, "FRONT BUMPER"](#) in "EI" section.
3. Disconnect washer pump connector and tube.
4. Pull out washer pump in direction shown by the arrow in the figure. Remove washer pump from washer tank.

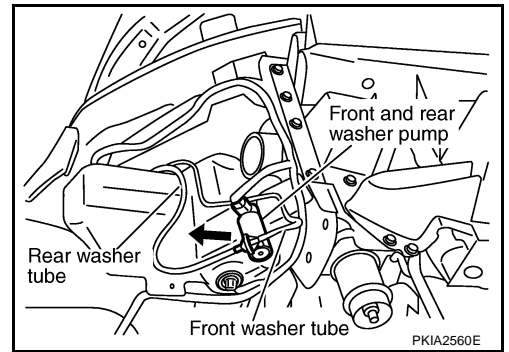

### INSTALLATION

Installation is the reverse order of removal.

#### CAUTION:

- When installing washer pump, there should be no packing twists, etc.
- Never misconnect the front tube and the rear tube to each side when the washer tube is being connected to the washer pump.

A  
B  
C  
D  
E  
F  
G  
H  
I  
J  
L  
M

WW

# REAR WIPER AND WASHER SYSTEM

## REAR WIPER AND WASHER SYSTEM

PFP:28710

### Components Parts and Harness Connector Location

AKS004X3

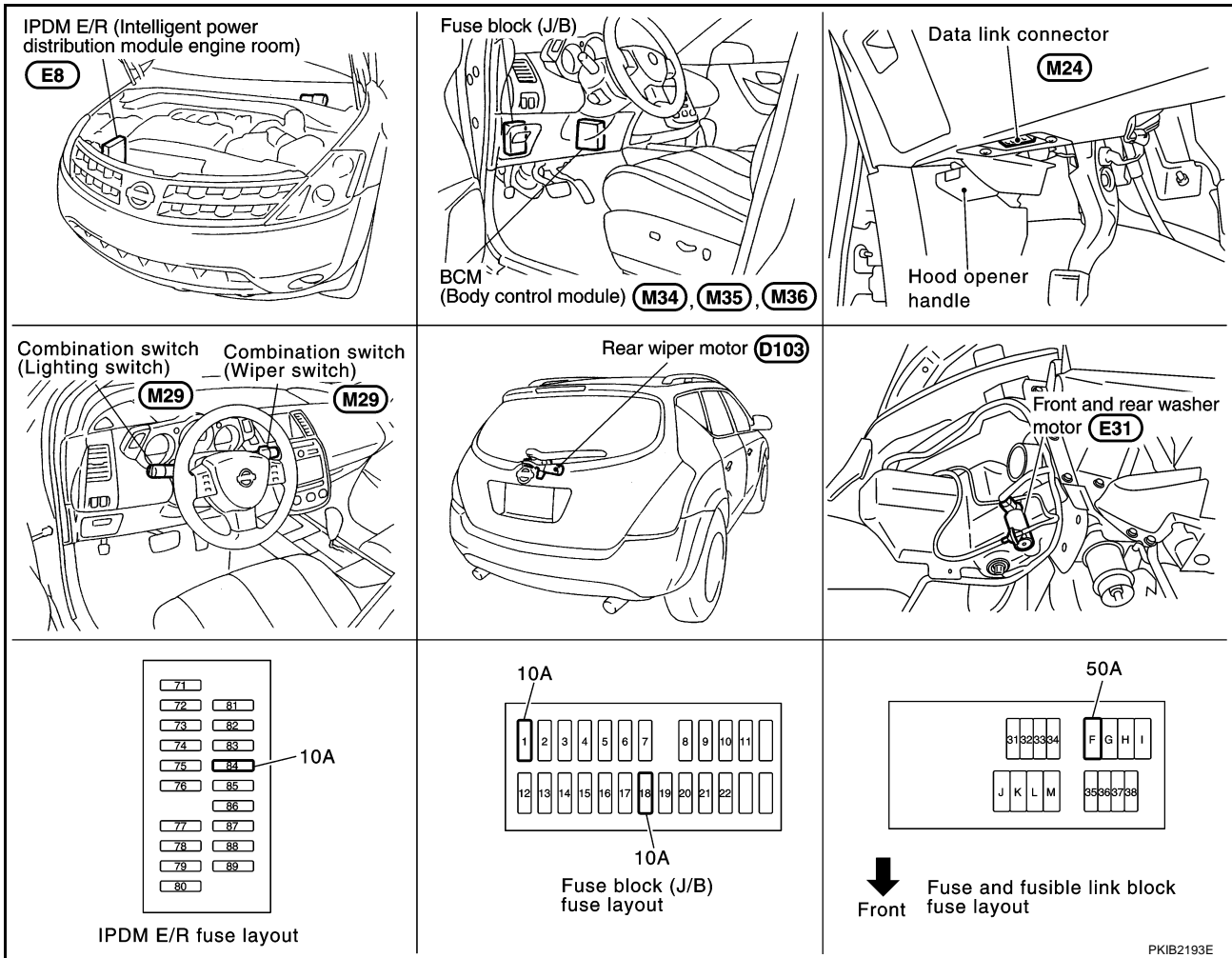

PKIB2193E

## System Description

AKS004X4

- Wiper switch (combination switch) is composed of a combination of 5 output terminals and 5 input terminals. Terminal combination status is read by BCM (body control module) when switch is turned ON.
- BCM (body control module) controls rear wiper ON and INT (intermittent) operation.

## OUT LINE

Power supplied all time

- through 50 A fusible link (letter F, located in fuse and fusible link block)
- to BCM terminal 55,
- through 10 A fuse [No. 18, located in fuse block (J/B)]
- to BCM terminal 42.

When ignition switch ON or START position, power is supplied

- through 10 A fuse [No. 1, located in fuse block (J/B)]
- to BCM terminal 38,
- through 10 A fuse [NO. 84, located in IPDM E/R (intelligent power distribution module engine room)]
- through IPDM E/R terminal 44
- to combination switch terminal 14.

Ground is supplied

- to BCM terminal 52
- through grounds E13, E26 and E28,

# REAR WIPER AND WASHER SYSTEM

- to combination switch terminal 12
- through grounds M14 and M78.

A

## REAR WIPER OPERATION

When wiper switch is in rear wiper ON position, BCM detect rear wiper ON signal by BCM wiper switch reading function.

B

When BCM operates rear wiper motor, power is supplied

- through BCM terminal 70
- to rear wiper motor 4.

C

Ground is supplied

- to rear wiper motor terminal 2
- through grounds B7 and B20.

D

With power and ground supplied, the rear wiper operates.

E

## INTERMITTENT OPERATION

The rear wiper motor operates the wiper arms at low speed approximately every 7 seconds.

When wiper switch is in rear wiper INT position, BCM detects rear wiper INT signal by BCM wiper switch reading function (Refer to [WW-7, "COMBINATION SWITCH READING FUNCTION"](#) ).

F

When BCM operates rear wiper motor, power supplied

- through BCM terminal 70
- to rear wiper motor 4.

G

Ground is supplied

- to rear wiper motor terminal 2
- through grounds B7 and B20.

H

With power and ground supplied, rear wiper operates at intermittent.

I

## AUTO STOP OPERATION

With rear wiper switch turned OFF, rear wiper motor will continue to operate until wiper arm reaches rear wiper stopper.

Then wiper motor turns the other way and wiper arm moves once until wiper arm reaches stopper.

J

## WASHER OPERATION

When wiper switch is in rear wiper washer position, BCM detects rear wiper washer signal by BCM wiper switch reading function (Refer to [WW-7, "COMBINATION SWITCH READING FUNCTION"](#) ), and combination switch (wiper switch) power is supplied

WW

- through combination switch terminal 11
- to front and rear washer motor terminal 2.

L

Ground is supplied

- to front and rear washer motor terminal 1
- through combination switch terminal 13
- to combination switch terminal 12
- through grounds M14 and M78.

M

With ground supplied, front and rear washer motor is operated.

When BCM detects that front and rear washer motor has operated for 0.4 seconds or longer, BCM operates rear wiper motor at low speed.

When BCM detects washer switch is OFF, low speed operation cycles approximately 3 times and then stops.

## BCM WIPER SWITCH READING FUNCTION

Refer to [WW-7, "COMBINATION SWITCH READING FUNCTION"](#) in FRONT WIPER AND WASHER SYSTEM.

# REAR WIPER AND WASHER SYSTEM

## Wiring Diagram — WIP/ R —

AKS004X5

WW-WIP/R-01

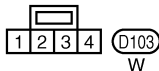
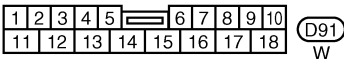
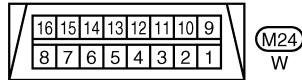
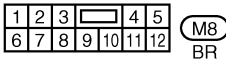
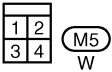
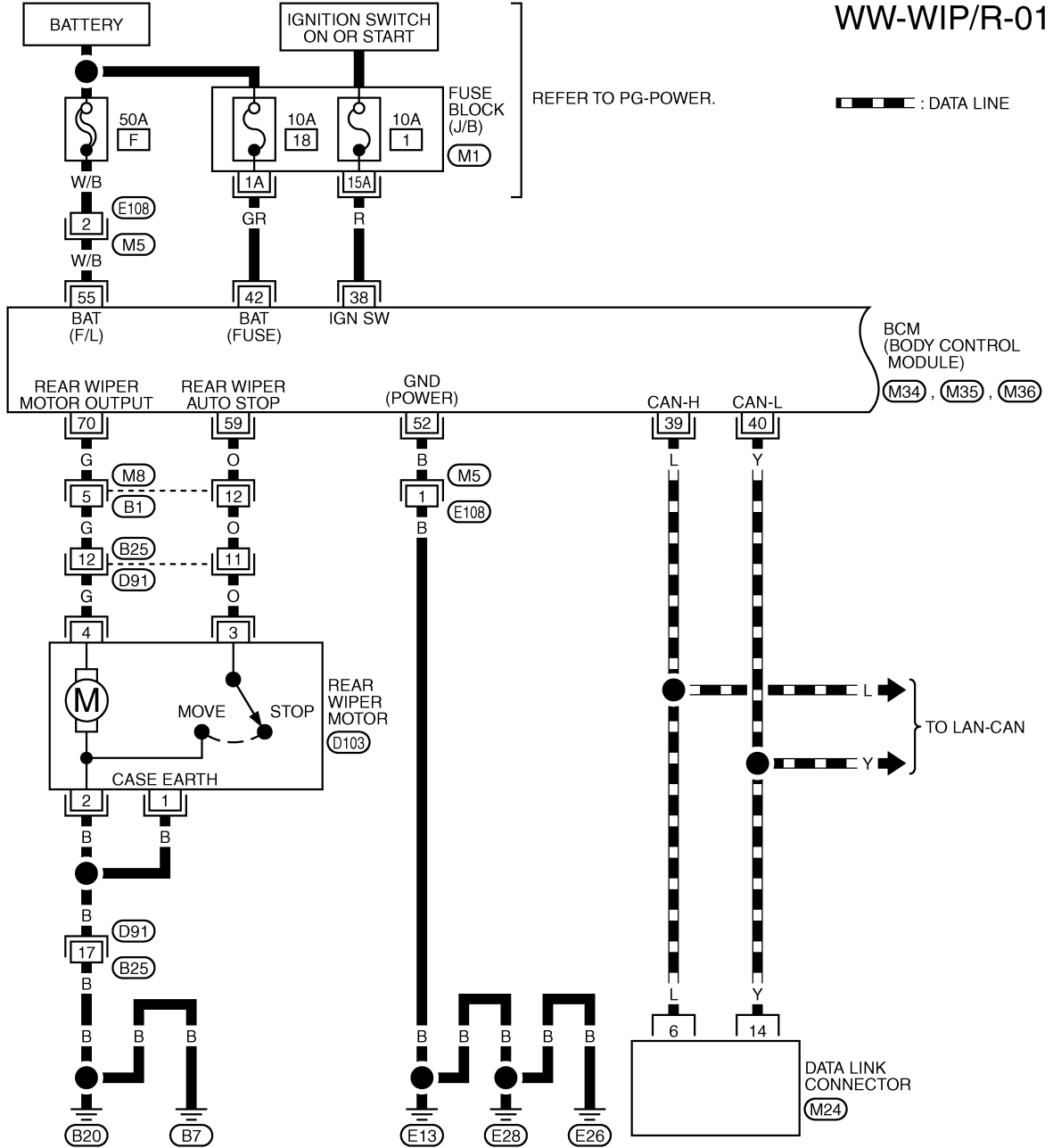

REFER TO THE FOLLOWING.

(M1) - FUSE BLOCK-JUNCTION BOX (J/B)

(M34), (M35), (M36)  
- ELECTRICAL UNITS

TKWB0497E



# REAR WIPER AND WASHER SYSTEM

WW-WIP/R-02

A  
B  
C  
D  
E  
F  
G  
H  
I  
J  
L  
M

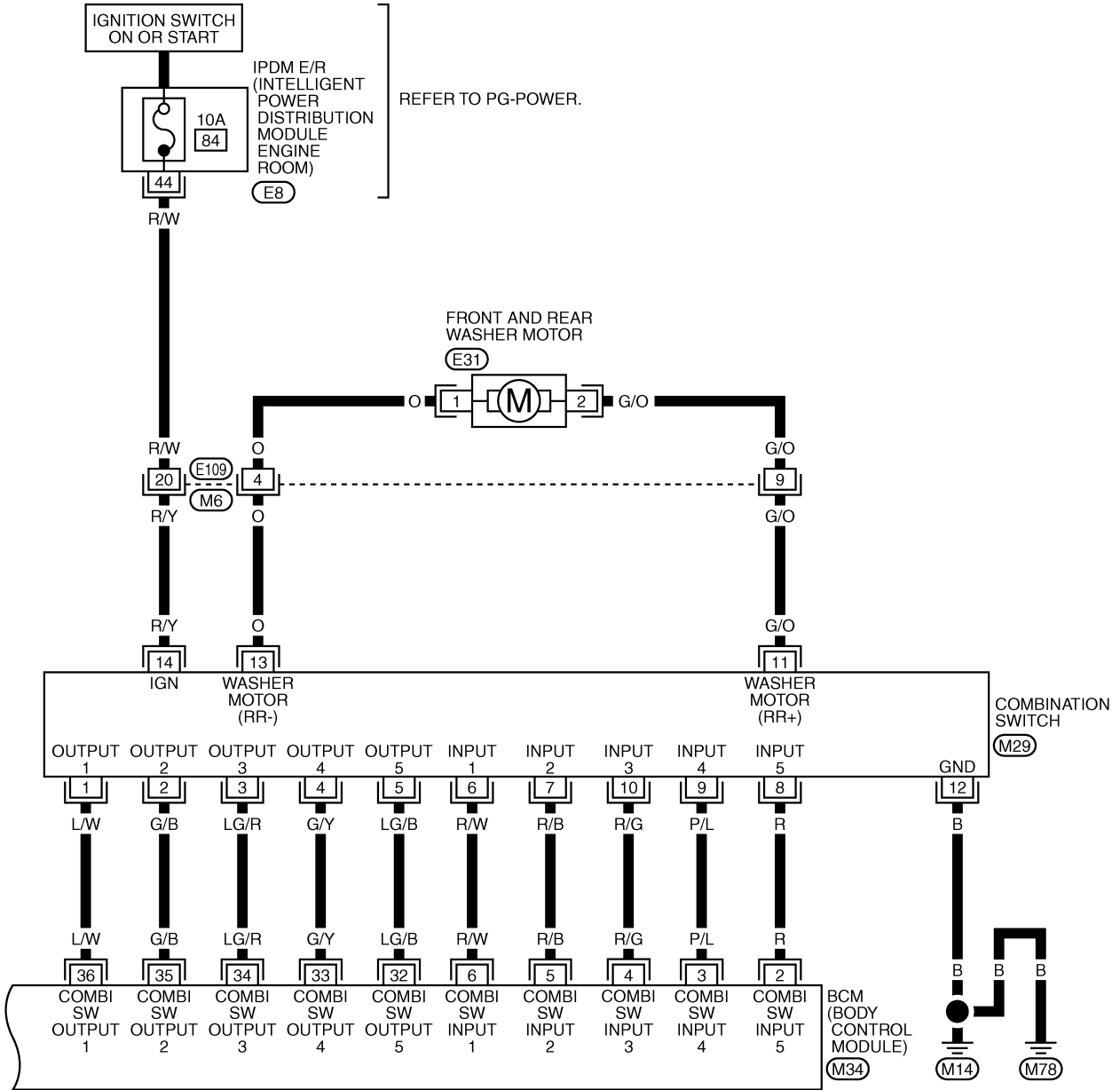

WW

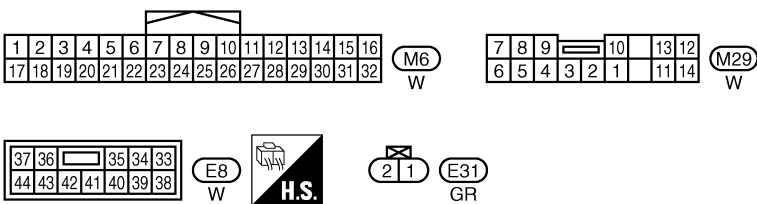





REFER TO THE FOLLOWING.  
(M34) -ELECTRICAL UNITS

TKWB0904E

# REAR WIPER AND WASHER SYSTEM

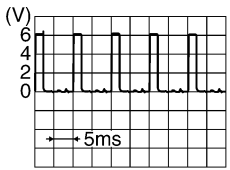
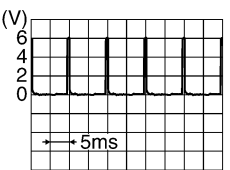
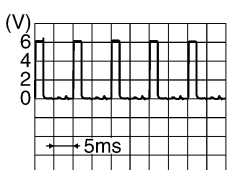
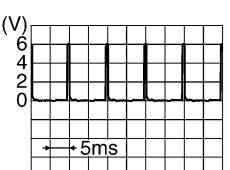
## Terminals and Reference Values for BCM

AKS00CRU

Terminal No.	Wire color	Signal name	Measuring condition		Reference value
			Ignition switch	Operation or condition	
2	R	Combination switch input 5	ON	Lighting switch and wiper switch OFF Wiper dial position 4	 <p style="text-align: right;">SKIA5291E</p>
3	P/L	Combination switch input 4	ON	Lighting switch and wiper switch OFF Wiper dial position 4	 <p style="text-align: right;">SKIA5292E</p>
4	R/G	Combination switch input 3	ON	Lighting switch and wiper switch OFF Wiper dial position 4	 <p style="text-align: right;">SKIA5291E</p>
5	R/B	Combination switch input 2	ON	Lighting switch and wiper switch OFF Wiper dial position 4	 <p style="text-align: right;">SKIA5292E</p>
6	R/W	Combination switch input 1			
32	LG/B	Combination switch output 5	ON	Lighting switch and wiper switch OFF Wiper dial position 4	 <p style="text-align: right;">SKIA5291E</p>
33	G/Y	Combination switch output 4	ON	Lighting switch and wiper switch OFF Wiper dial position 4	 <p style="text-align: right;">SKIA5292E</p>
34	LG/R	Combination switch output 3	ON	Lighting switch and wiper switch OFF Wiper dial position 4	 <p style="text-align: right;">SKIA5291E</p>

# REAR WIPER AND WASHER SYSTEM

Terminal No.	Wire color	Signal name	Measuring condition		Reference value	
			Ignition switch	Operation or condition		
35	G/B	Combination switch output 2	ON	Lighting switch and wiper switch OFF Wiper dial position 4		
36	L/W	Combination switch output 1				
38	R	Ignition switch (ON)	ON	—	Battery voltage	
39	L	CAN – H	—	—	—	
40	Y	CAN – L	—	—	—	
42	GR	Battery power supply	OFF	—	Battery voltage	
52	B	Ground	ON	—	Approx. 0V	
55	W/B	Battery power supply	OFF	—	Battery voltage	
59	O	Rear wiper auto stop signal	ON	Wiper operating	Approx. 0V	
				Wiper stopped	Battery voltage	
70	G	Rear wiper motor output signal	ON	Wiper switch	OFF	Approx. 0V
					ON	Battery voltage

## How to Proceed With Trouble Diagnosis

AKS004X7

1. Confirm the symptoms and customer complaint.
2. Understand operation description and function description. Refer to [WW-38, "System Description"](#).
3. Perform the Preliminary Check. Refer to [WW-43, "Preliminary Check"](#).
4. Check symptom and repair or replace the cause of malfunction.
5. Does the rear wiper operate normally? If YES, GO TO 6. If NO, GO TO 4.
6. INSPECTION END

## Preliminary Check

AKS004X8

### CHECK POWER SUPPLY AND GROUND CIRCUIT

WW

#### 1. CHECK FUSE

- Check for blown fuses.

Unit	Power source	Fuse and fusible link No.
BCM	Battery	F
		18
	Ignition ON or START	1
Front and rear washer motor via combination switch	Ignition ON or START	84

Refer to [WW-40, "Wiring Diagram — WIP/ R —"](#).

#### OK or NG

OK >> GO TO 2.

NG >> If fuse is blown, be sure to eliminate cause of malfunction before installing new fuse. Refer to [PG-3, "POWER SUPPLY ROUTING CIRCUIT"](#).

# REAR WIPER AND WASHER SYSTEM

## 2. CHECK POWER SUPPLY CIRCUIT

1. Turn ignition switch OFF.
2. Disconnect BCM connector.
3. Check voltage between BCM harness connector terminal and ground.

Terminal		Ignition switch position	
(+)		(-)	
Connector	Terminal (Wire color)	OFF	ON
M35	42 (GR)	Battery voltage	Battery voltage
M35	55 (W/B)	Battery voltage	Battery voltage
M34	38 (R)	0V	Battery voltage

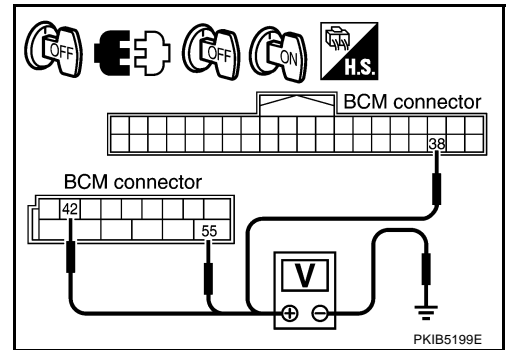

OK or NG

OK >> GO TO 3.

NG >> Check harness for open or short between fuse, fusible link and BCM.

## 3. CHECK GROUND CIRCUIT

Check continuity between BCM harness connector and ground.

Terminal		Ground	Continuity
Connector	Terminal (Wire color)		
M35	52 (B)		Yes

OK or NG

OK >> INSPECTION END

NG >> Check harness ground circuit.

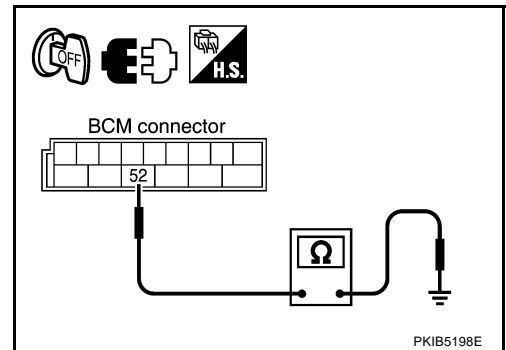

# REAR WIPER AND WASHER SYSTEM

## CONSULT-II Functions (BCM)

AKS00CRV

CONSULT-II can display each diagnostic item using the diagnostic test modes shown following.

BCM diagnosis position	Diagnosis mode	Description
WIPER	DATA MONITOR	Displays BCM input data in real time.
	ACTIVE TEST	Device operation can be checked by applying a drive signal to device.

## CONSULT-II BASIC OPERATION

### CAUTION:

If CONSULT-II is used with no connection of CONSULT-II CONVERTER, malfunctions might be detected in self-diagnosis depending on control unit which carry out CAN communication.

1. With the ignition switch OFF, connect CONSULT-II and CONSULT-II CONVERTER to the data link connector, and then turn the ignition switch ON.

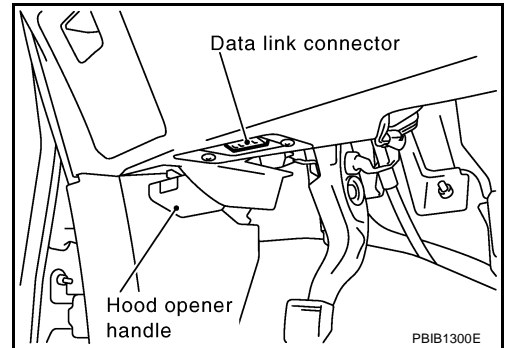

2. Touch "START (NISSAN BASED VHCL)".

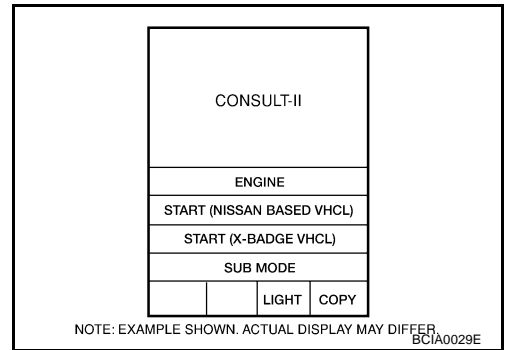

3. Touch "BCM" on "SELECT SYSTEM" screen.  
If "BCM" is not indicated, refer to [GI-39, "CONSULT-II Data Link Connector \(DLC\) Circuit"](#).

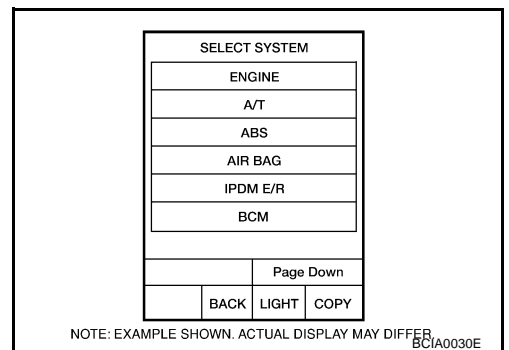

4. Touch "WIPER".

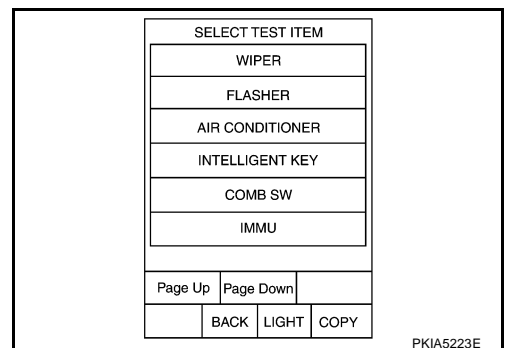

# REAR WIPER AND WASHER SYSTEM

## DATA MONITOR

### Operation Procedure

1. Touch "WIPER" on "SELECT TEST ITEM" screen.
2. Touch "DATA MONITOR" on "SELECT DIAG MODE" screen.
3. Touch either "ALL SIGNALS" or "SELECTION FROM MENU" on "SELECT MONITOR ITEM" screen.

ALL SIGNALS	Monitors all the signals.
SELECTION FROM MENU	Selects items and monitors them.

4. When "SELECTION FROM MENU" is selected, touched items to be monitored. If "ALL SIGNALS" is selected, all items will be monitored.
5. Touch "START".
6. Touch "RECORDING START" while monitoring to record the status of the item being monitored. To stop recording, touch "RECORDING STOP".

### Display Item List

Monitor item		Contents
IGN ON SW	"ON/OFF"	Displays "ignition switch ON (ON)/Other OFF or ACC (OFF)" status as judged from ignition switch signal.
IGN SW CAN	"ON/OFF"	Displays "ignition switch ON (ON)/Other OFF or ACC (OFF)" status as judged from CAN communication signal.
FR WIPER HI	"ON/OFF"	Displays "FRONT WIPER HI (ON)/Other (OFF)" status as judged from wiper switch signal.
FR WIPER LOW	"ON/OFF"	Displays "FRONT WIPER LOW (ON)/Other (OFF)" status as judged from wiper switch signal.
FR WIPER INT	"ON/OFF"	Displays "FRONT WIPER INT (ON)/Other (OFF)" status as judged from wiper switch signal.
FR WASHER SW	"ON/OFF"	Displays "FRONT WASHER Switch (ON)/Other (OFF)" status as judged from wiper switch signal.
INT VOLUME	"1 - 7"	Displays intermittent operation dial position setting (1 - 7) as judged from wiper switch signal.
FR WIPER STOP	"ON/OFF"	Displays "Stopped (ON)/Operating (OFF)" status as judged from the auto-stop signal.
VEHICLE SPEED	"km/h"	Displays vehicle speed status as judged from vehicle speed signal.
RR WIPER ON	"ON/OFF"	Displays "Rear Wiper ON (ON)/Other (OFF)" status as judged from wiper switch signal.
RR WIPER INT	"ON/OFF"	Displays "Rear Wiper INT (ON)/Other (OFF)" status as judged from wiper switch signal.
RR WASHER SW	"ON/OFF"	Displays "Rear Washer Switch (ON)/Other (OFF)" status as judged from wiper switch signal.
RR WIPER STOP	"ON/OFF"	Displays "Rear Wiper Stop (ON)/Other (OFF)" status, as judged from wiper switch signal.
RR WIPER STP2 <sup>NOTE</sup>	"OFF"	—

#### NOTE:

This item is displayed, but cannot be monitored.

## ACTIVE TEST

### Operation Procedure

1. Touch "WIPER" on the "SELECT TEST ITEM" screen.
2. Touch "ACTIVE TEST" on "SELECT DIAG MODE" screen.
3. Touch items to be tested, and check operation.
4. During operation check, touching "STOP" deactivates operation.

### Display Item List

Test item	Display on CONSULT-II screen	Description
Front wiper output	FR WIPER	With a certain operation (OFF, HI, LO, INT), the front wiper can be operated.
Rear wiper output	RR WIPER	Rear wiper can be operated by any ON-OFF operation.

# REAR WIPER AND WASHER SYSTEM

AKS00CRW

## Rear Wiper Does Not Operate

### 1. CHECK CIRCUIT BETWEEN COMBINATION SWITCH AND BCM

④ With CONSULT-II

1. Select "BCM" on CONSULT-II, and select "WIPER" on "SELECT TEST ITEM" screen.
2. Select "DATA MONITOR" on "SELECT DIAG MODE" screen. Make sure that "RR WIPER ON", turn ON-OFF according to front wiper switch operation.

DATA MONITOR	
MONITOR	
FR WASHER SW	OFF
INT VOLUME	7
FR WIPER STOP	ON
VEHICLE SPEED	0.0 km/h
RR WIPER ON	OFF
RR WIPER INT	OFF
RR WASHER SW	OFF
RR WIPER STOP	OFF
RR WIPER STP2	OFF
Page Up	
RECORD	
MODE	BACK
LIGHT	COPY

PKIB1785E

⊗ Without CONSULT-II

Refer to [LT-145, "Combination Switch Inspection"](#).

OK or NG

OK >> GO TO 2.

NG >> Check combination switch (wiper switch). Refer to [LT-145, "Combination Switch Inspection"](#).

### 2. ACTIVE TEST

④ With CONSULT-II

1. Select "BCM" on CONSULT-II, and select "WIPER" on "SELECT SYSTEM" screen.
2. Select "ACTIVE TEST" on "SELECT DIAG MODE" screen.
3. Select "REAR WIPER" on "SELECT TEST ITEM" screen.
4. Confirm that rear wiper operates normally.

ACTIVE TEST	
RR WIPER	OFF
ON	
MODE	
BACK	LIGHT
COPY	

SKIA3503E

⊗ Without CONSULT-II

GO TO 3.

Does rear wiper operate normally?

YES >> Replace BCM. Refer to [BCS-16, "Removal and Installation of BCM"](#).

NO >> GO TO 3.

### 3. CHECK BCM

With rear wiper switch ON, check voltage between rear wiper motor harness connector D103 terminal 4 (G) and ground.

**4 (G) - Ground : Battery voltage.**

OK or NG

OK >> GO TO 4.

NG >> GO TO 5.

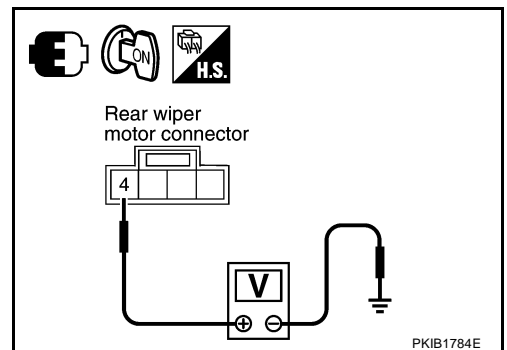

A

B

C

D

E

F

G

H

I

J

WW

L

M

# REAR WIPER AND WASHER SYSTEM

## 4. CHECK GROUND CIRCUIT

1. Turn ignition switch OFF.
2. Disconnect rear wiper motor connector.
3. Check continuity between rear wiper motor harness connector D103 terminal 2 (B) and ground.

**2 (B) - Ground : Continuity should exist.**

OK or NG

- OK >> Replace rear wiper motor.  
 NG >> Repair harness or connector.

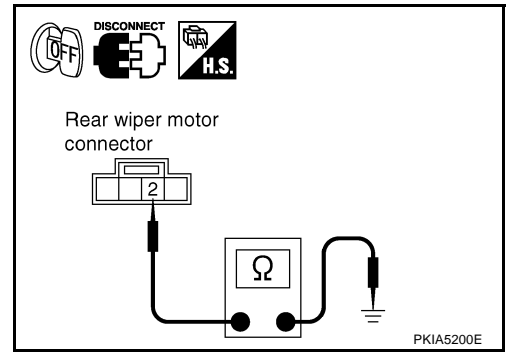

## 5. CHECK REAR WIPER CIRCUIT

1. Turn ignition switch OFF.
2. Disconnect BCM connector and rear wiper motor connector.
3. Check continuity between BCM harness connector M36 terminals 70 (G) and rear wiper motor harness connector D103 terminals 4 (G).

**70 (G) - 4 (G) : Continuity should exist.**

4. Check continuity between BCM harness connector M36 terminals 70 (G) and ground.

**70 (G) - Ground : Continuity should not exist.**

OK or NG

- OK >> Replace BCM. Refer to [BCS-16, "Removal and Installation of BCM"](#) .  
 NG >> Repair harness or connector.

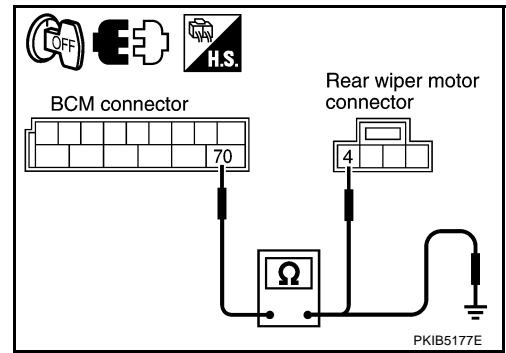

## Rear Wiper Does Not Return to Stop Position

AKS00CRX

### 1. CHECK REAR WIPER MOTOR CIRCUIT

With CONSULT-II

1. Select "BCM" on CONSULT-II, and select "WIPER" on "SELECT TEST ITEM" screen.
2. Select "DATA MONITOR" on "SELECT DIAG MODE" screen. Make sure that "RR WIPER STOP", turn ON-OFF linked with rear wiper switch operation.

Without CONSULT-II

GO TO 2.

OK or NG

- OK >> Replace BCM. Refer to [BCS-16, "Removal and Installation of BCM"](#) .  
 NG >> GO TO 2.

DATA MONITOR	
MONITOR	
FR WASHER SW	OFF
INT VOLUME	7
FR WIPER STOP	ON
VEHICLE SPEED	0.0 km/h
RR WIPER ON	OFF
RR WIPER INT	OFF
RR WASHER SW	OFF
RR WIPER STOP	OFF
RR WIPER STP2	OFF
Page Up	
RECORD	
MODE	BACK LIGHT COPY

PKIB1785E



# REAR WIPER AND WASHER SYSTEM

## 2. CHECK REAR WIPER AUTO STOP CIRCUIT

1. Turn ignition switch OFF.
2. Disconnect BCM connector and rear wiper motor connector.
3. Check continuity between BCM harness connector M36 terminal 59 (O) and rear wiper motor harness connector D103 terminal 3 (O).

**59 (O) - 3 (O) : Continuity should exist.**

4. Check continuity between BCM harness connector M36 terminal 59 (O) and ground.

**59 (O) - Ground : Continuity should not exist.**

5. Check continuity between rear wiper motor harness connector D103 terminal 2 (B) and ground.

**2 (B) - Ground : Continuity should exist.**

OK or NG

OK >> GO TO 3.

NG >> Repair harness or connector.

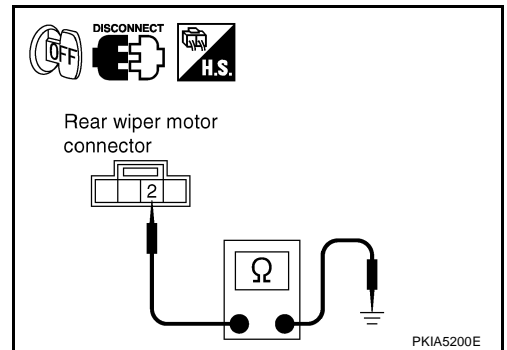
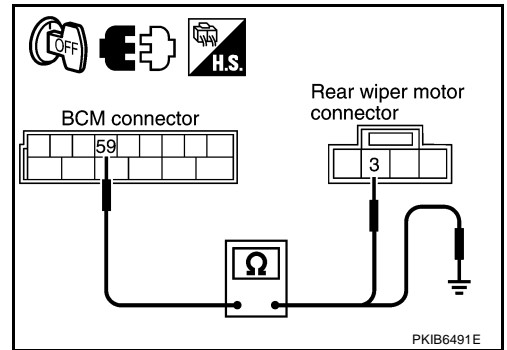

## 3. CHECK REAR WIPER MOTOR SIGNAL

1. Connect BCM connector and rear wiper motor connector.
2. Turn ignition switch ON.
3. Check voltage between rear wiper motor harness connector terminal and ground while rear wiper motor is stopped and while it is operating.

Terminal		(-)	Condition	Voltage
Rear wiper motor (+)	Connector			
	Terminal (Wire color)			
D103	3 (O)	Ground	Wiper stopped	Battery voltage
			Wiper operating	Approx. 0V

OK or NG

OK >> Replace BCM. Refer to [BCS-16, "Removal and Installation of BCM"](#) .

NG >> Replace rear wiper motor.

### Only Rear Wiper ON Does Not Operate

AKS00CRY

Refer to [LT-145, "Combination Switch Inspection"](#) , and inspect it.

### Only Rear Wiper INT Does Not Operate

AKS00CRZ

Refer to [LT-145, "Combination Switch Inspection"](#) , and inspect it.

### Wiper Does Not Wipe When Rear Washer Operates

AKS00CS0

Refer to [LT-145, "Combination Switch Inspection"](#) , and inspect it.

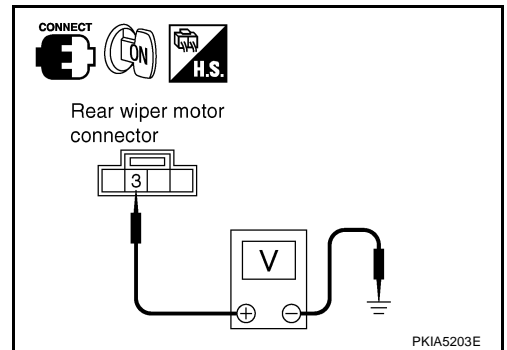

A  
B  
C  
D  
E  
F  
G  
H  
I  
J  
L  
M

WW

# REAR WIPER AND WASHER SYSTEM

AKS00CS1

## Rear Wiper Do Not Stop

### 1. CHECK CIRCUIT BETWEEN COMBINATION SWITCH AND BCM

④ With CONSULT-II

1. Select "BCM" on CONSULT-II, and select "WIPER" on "SELECT TEST ITEM" screen.
2. Select "DATA MONITOR" on "SELECT DIAG MODE" screen. Make sure that "RR WIPER INT", "RR WIPER ON", and "RR WASHER SW" turn ON-OFF according to wiper switch operation.

⊗ Without CONSULT-II

Refer to [LT-145, "Combination Switch Inspection"](#).

OK or NG

OK >> Replace BCM. Refer to [BCS-16, "Removal and Installation of BCM"](#).

NG >> Check combination switch (wiper switch). Refer to [LT-145, "Combination Switch Inspection"](#).

DATA MONITOR	
MONITOR	
FR WASHER SW	OFF
INT VOLUME	7
FR WIPER STOP	ON
VEHICLE SPEED	0.0 km/h
RR WIPER ON	OFF
RR WIPER INT	OFF
RR WASHER SW	OFF
RR WIPER STOP	OFF
RR WIPER STP2	OFF
Page Up	
RECORD	
MODE	BACK
LIGHT	COPY

PKIB1785E

## Removal and Installation of Rear Wiper Arm, Adjustment of Wiper Arms Stop Location

AKS00ANP

### REMOVAL

1. Operate wiper motor, and stop it at the auto stop position.
2. Remove wiper arm cover and mounting nut, and then remove wiper arm from vehicle.

### INSTALLATION

1. Clean up the pivot area as illustrated. This will reduce possibility of wiper arm looseness.

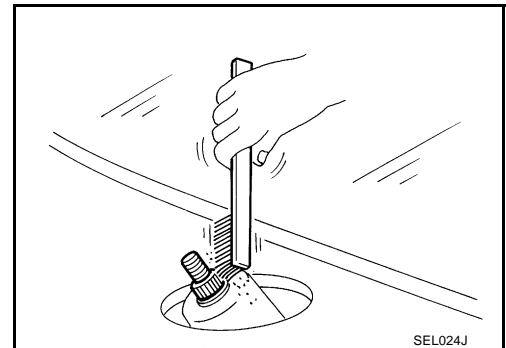

2. Prior to wiper arm installation, turn on wiper switch to operate wiper motor and then turn it "OFF" (Auto Stop).
3. Lift the blade up and then set it down onto glass surface to set the blade center to clearance "L" immediately before tightening nut.
4. Eject washer fluid. Turn on wiper switch to operate wiper motor and then turn it "OFF".
5. Ensure that wiper blades stop within clearance "L".

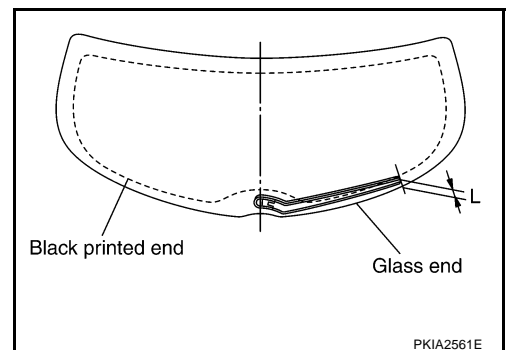

**Clearance "L" : 20.5 - 35.5 mm (0.807 - 1.398 in)**

- Tighten wiper arm nut to specified torque.

**Rear wiper arm mounting nut  : 8.8 N·m (0.90 kg·m, 78 in·lb)**

### ADJUSTMENT

Refer to [WW-50, "INSTALLATION"](#).

# REAR WIPER AND WASHER SYSTEM

## Removal and Installation of Rear Wiper Motor

AKS00ANQ

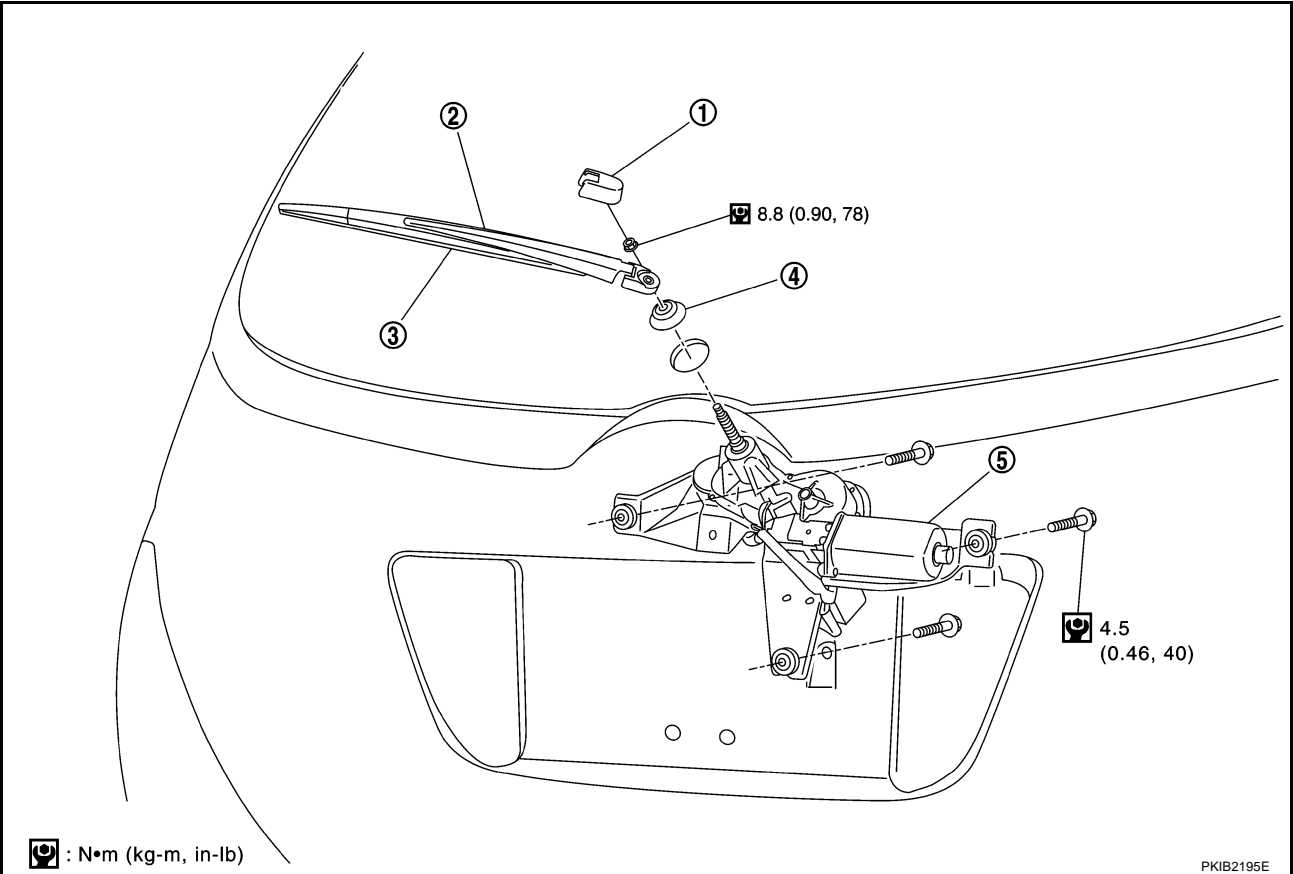

A  
B  
C  
D  
E  
F  
G  
H  
I  
J

1. Wiper arm cover
2. Wiper arm
3. Wiper blade
4. Pivot cap
5. Rear wiper motor

### REMOVAL

1. Remove wiper arm. Refer to [WW-50, "Removal and Installation of Rear Wiper Arm, Adjustment of Wiper Arms Stop Location"](#).
2. Remove pivot cap.
3. Remove back door finisher. Refer to [EI-40, "BACK DOOR TRIM"](#) in "EI" section.
4. Disconnect rear wiper motor connector.
5. Remove rear wiper motor mounting bolts and remove rear wiper motor.

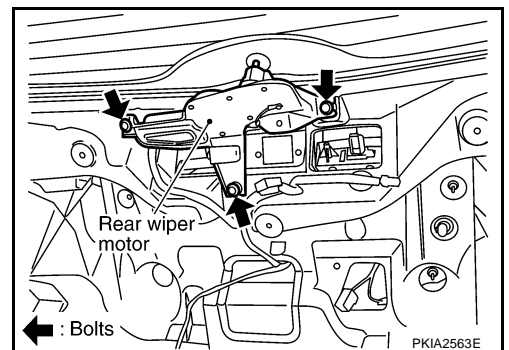

WW  
L  
M

### INSTALLATION

1. Attach pivot cap.
2. Install rear wiper motor to the vehicle.

**Rear wiper motor mounting bolts**  : 4.5 N·m (0.46 kg-m, 40 in-lb)

3. Connect rear wiper motor to the connector. Turn rear wiper switch ON to operate rear wiper motor, then turn wiper switch OFF (auto stop).
4. Install back door finisher. Refer to [EI-40, "BACK DOOR TRIM"](#) in "EI" section.
5. Attach wiper arm. Refer to [WW-50, "Removal and Installation of Rear Wiper Arm, Adjustment of Wiper Arms Stop Location"](#).

### CAUTION:

- Never drop the wiper motor or cause it to contact other parts.

# REAR WIPER AND WASHER SYSTEM

## Removal and Installation of Rear Wiper Blade REMOVAL

AKS00ANR

1. Remove wiper arm. Refer to [WW-50, "REMOVAL"](#) .
2. Turn wiper blade assembly 90 degrees against the wiper arm, and pull the assembly out and downward for removal.

### CAUTION:

Replace the entire wiper blade assembly, not just the wiper blade.

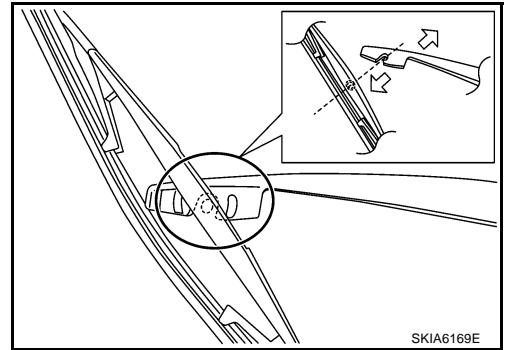

## INSTALLATION

Installation is the reverse order of removal.

## Washer Nozzle Adjustment

AKS00ANS

- Adjust washer nozzle with suitable tool as shown in the figure.

**Adjustable range** :  $\pm 0.7^\circ$  (vertical direction)  
:  $+7^\circ, -3^\circ$  (horizontal direction)

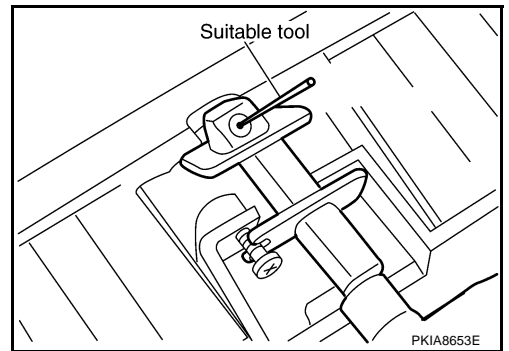

Unit : mm (in)

h (height)	23.3 (0.91)
$\phi$ (spray position range)	30 (1.18)

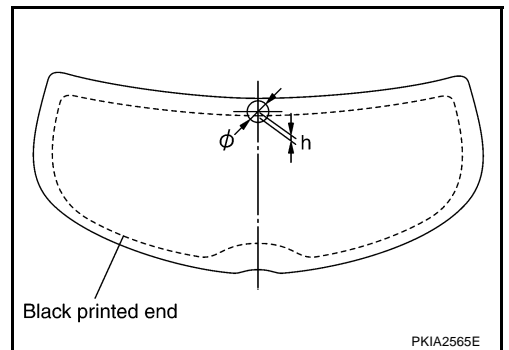

# REAR WIPER AND WASHER SYSTEM

## Washer Tube Layout

AKS00ANT

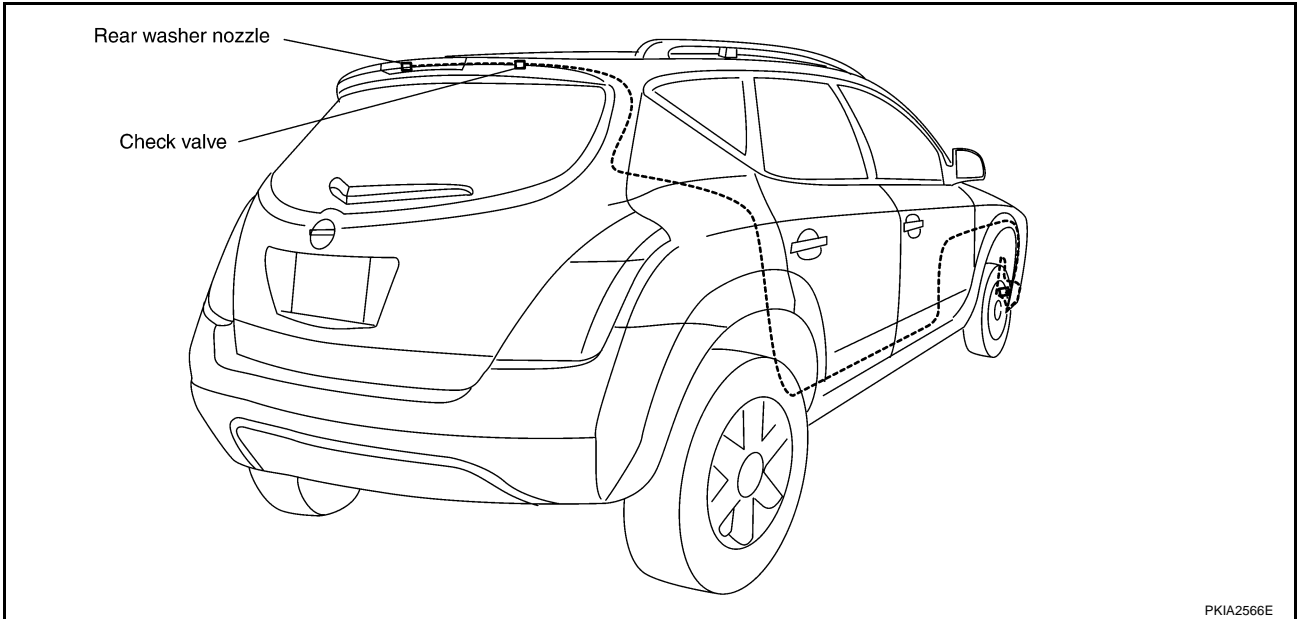

## Removal and Installation of Rear Washer Nozzle

AKS00ANU

1. Remove high-mounted stop lamp. Refer to [LT-149, "High-Mounted Stop Lamp"](#) in "LT" section.
2. Remove the rear washer nozzle mounting screw and remove it.
3. Installation is the reverse order of removal.

- Tighten rear washer nozzle mounting screw to specified torque.

**Rear washer nozzle mounting screw**  : 0.4 N·m (0.04 kg·m, 4 in·lb)

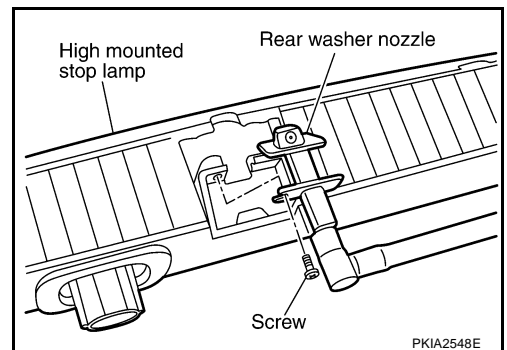

### CAUTION:

- After tightened rear washer nozzle mounting screw, make sure that the rear washer nozzle does not come off when it is pulled downward at 49N (5kg, 11lb) as shown in the figure. If the washer nozzle come off, replace it together with a new high-mounted stop lamp assembly.

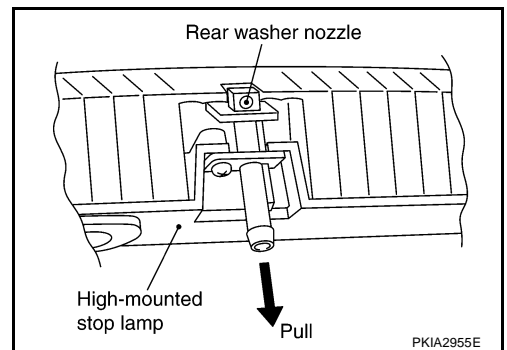

A  
B  
C  
D  
E  
F  
G  
H  
I  
J  
L  
M

WW

# REAR WIPER AND WASHER SYSTEM

## Check Valve Inspection

AKS00ANV

- A check valve is provided in the washer fluid line. Be careful not to connect check valve to washer tube in the wrong direction.

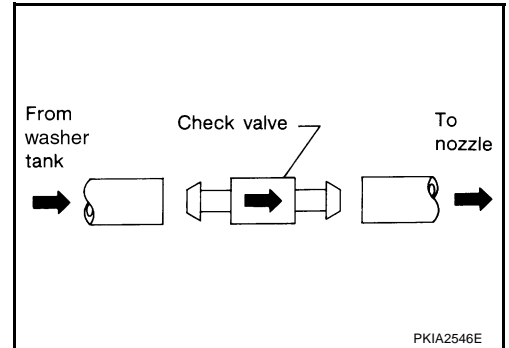

## Removal and Installation of Rear Wiper and Washer Switch

AKS00ANW

Refer to [WW-36, "Removal and Installation of Front Wiper and Washer Switch"](#) .

## Removal and Installation of Washer Tank

AKS00ANX

Refer to [WW-36, "Removal and Installation of Washer Tank"](#) .

## Removal and Installation of Washer Pump

AKS00ANY

Refer to [WW-37, "Removal and Installation of Washer Pump"](#) .

# POWER SOCKET

## POWER SOCKET

PPF:253A2

### Wiring Diagram — P/SCKT —

AKS004NM

## WW-P/SCKT-01

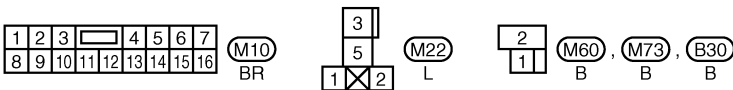
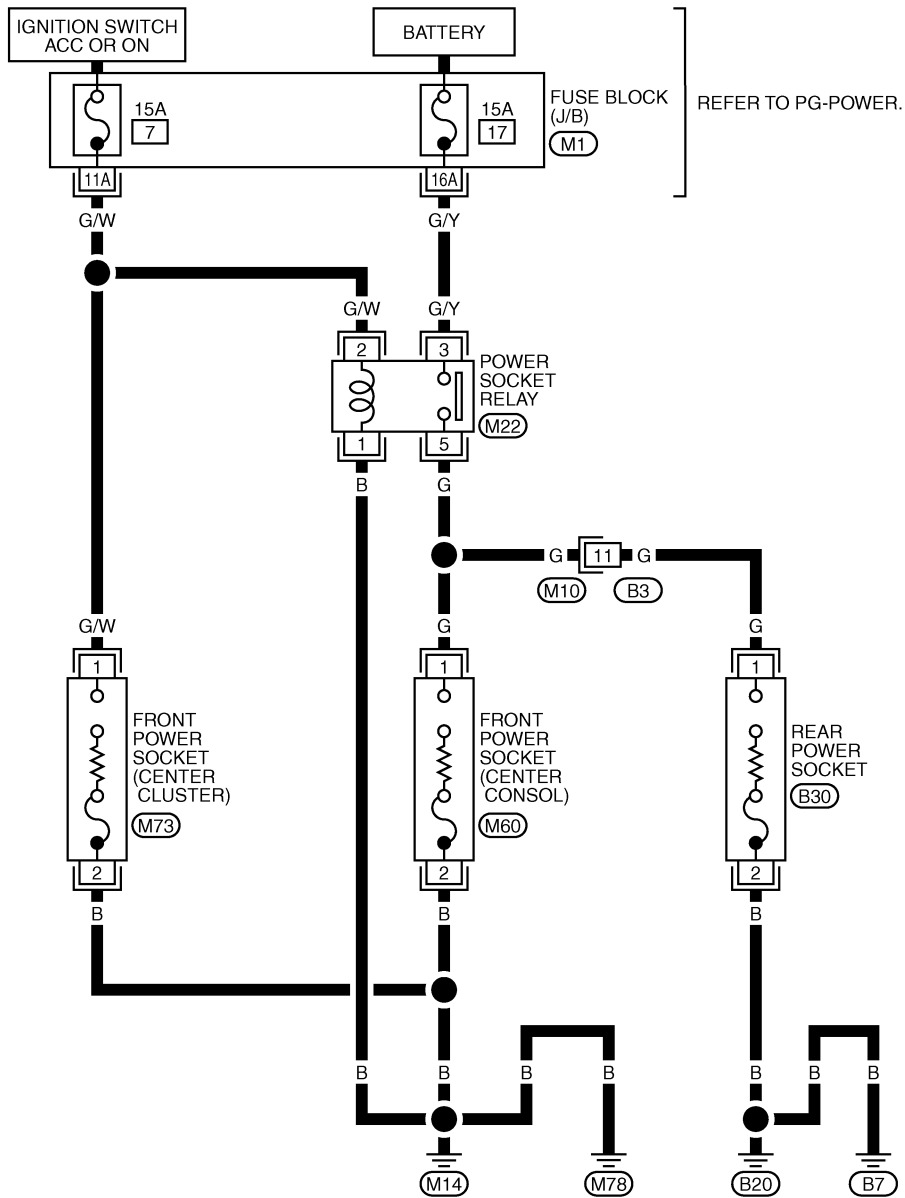

REFER TO THE FOLLOWING.  
**(M1)** - FUSE BLOCK-JUNCTION BOX (J/B)

A  
B  
C  
D  
E  
F  
G  
H  
I  
J  
K  
L  
M

WW

# POWER SOCKET

## Removal and Installation of Instrument Power Socket

AKS004NN

### REMOVAL

1. Remove inner socket with power socket lid assembly from the instrument panel, while pressing the pawls.
2. Disconnect power socket connector.
3. Remove inner socket from power socket lid assembly, while pressing the hook out from square hole.

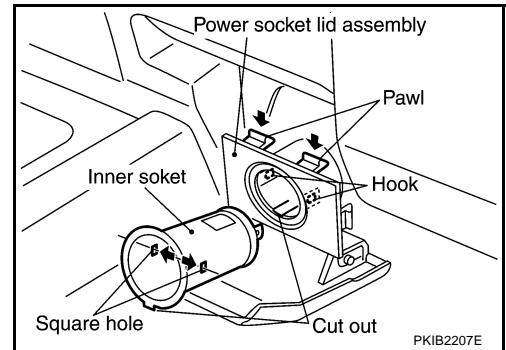

### INSTALLATION

Installation is the reverse order of removal.

## Removal and Installation of Luggage Room Power Socket

AKS005I6

### REMOVAL

1. Remove inner socket from the ring, while pressing the hook on the ring out from square hole.
2. Remove luggage side finisher lower (right). Refer to [EI-38, "LUGGAGE FLOOR TRIM"](#) in "EI" section.
3. Turn holder nut counterclockwise and unlock it.
4. Remove the ring from inner trim.

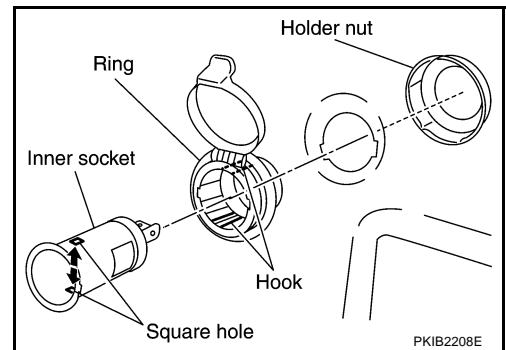

### INSTALLATION

Installation is the reverse order of removal.

## Removal and Installation of Console Power Socket

AKS005I5

### REMOVAL

1. Remove console box. Refer to [IP-17, "CENTER CONSOLE ASSEMBLY"](#) in "IP" section.
2. Remove inner socket from the ring, while pressing the hook on the ring out from square hole.
3. Remove power socket finisher assembly mounting screws and remove it.
4. Remove the ring from power socket finisher while pressing pawls.

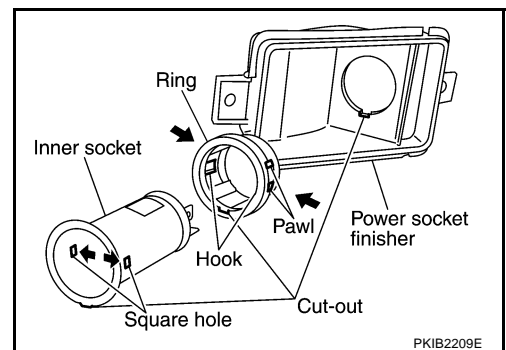

### INSTALLATION

Installation is the reverse order of removal.



# HORN

PPF:25610

## HORN

### Wiring Diagram — HORN —

AKS004NO

## WW-HORN-01

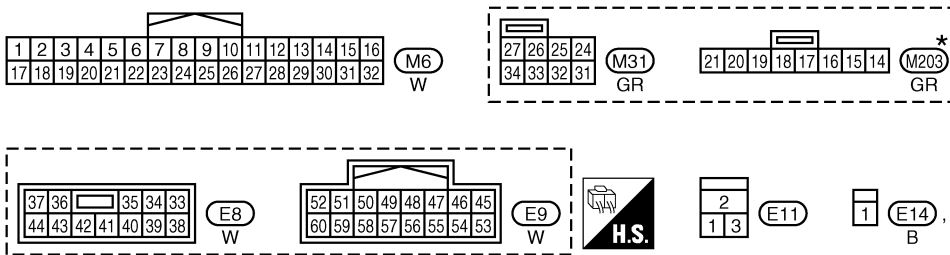
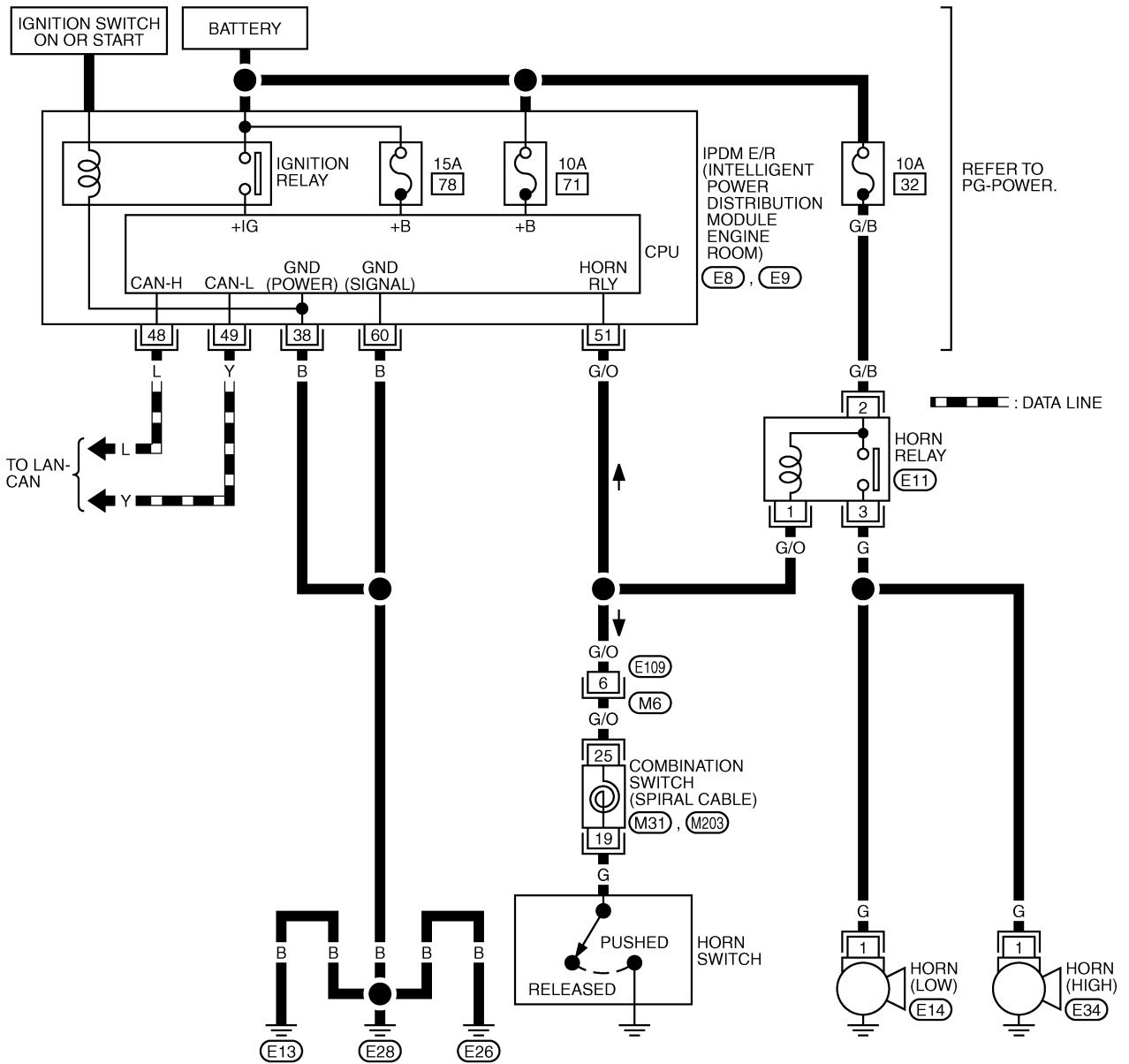

\*: THIS CONNECTOR IS NOT SHOWN IN "HARNES LAYOUT", PG SECTION.

TKWB0498E

# HORN

AKS004NP

## Removal and Installation

### REMOVAL

1. Remove front bumper. Refer to [EI-14, "FRONT BUMPER"](#) in "EI" section.
2. Disconnect horn connector.
3. Remove horn bolt and remove horn from vehicle.

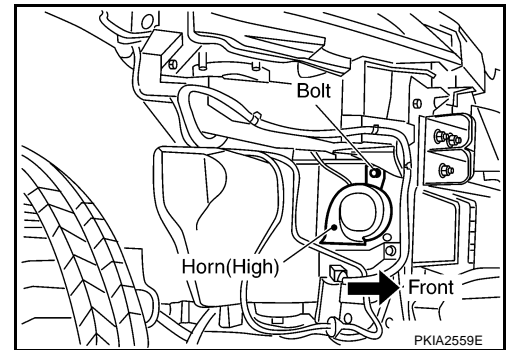
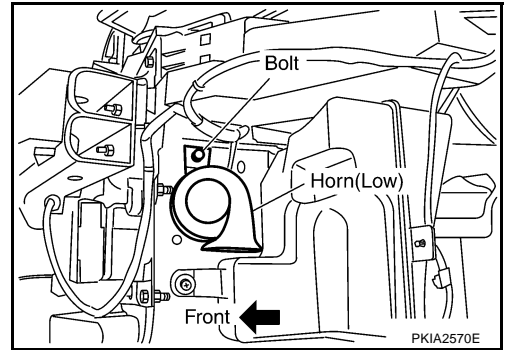

### INSTALLATION

Installation is the reverse order of removal.

- Tighten horn bolt to specified torque.

**Horn mounting bolt**  : 17.1 N·m (1.7 kg-m, 13 ft-lb)