

A
B
C
D

WT

SECTION

ROAD WHEELS & TIRES

CONTENTS

WT

<p>PREPARATION 2</p> <p style="padding-left: 20px;">Special Service Tools 2</p> <p style="padding-left: 20px;">Commercial Service Tools 2</p> <p>NOISE, VIBRATION AND HARSHNESS (NVH)</p> <p>TROUBLESHOOTING 3</p> <p style="padding-left: 20px;">NVH Troubleshooting Chart 3</p> <p>ROAD WHEEL 4</p> <p style="padding-left: 20px;">Inspection 4</p> <p style="padding-left: 40px;">ALUMINUM WHEEL 4</p> <p style="padding-left: 40px;">STEEL WHEEL 4</p> <p>ROAD WHEEL TIRE ASSEMBLY 5</p> <p style="padding-left: 20px;">Balancing Wheels (Bonding Weight Type) 5</p> <p style="padding-left: 20px;">REMOVAL 5</p> <p style="padding-left: 20px;">WHEEL BALANCE ADJUSTMENT 5</p> <p style="padding-left: 20px;">Rotation 6</p> <p>LOW TIRE PRESSURE WARNING SYSTEM 7</p> <p style="padding-left: 20px;">System Components 7</p> <p style="padding-left: 20px;">System Description 7</p> <p style="padding-left: 40px;">TRANSMITTER 7</p> <p style="padding-left: 40px;">ANTENNA 8</p> <p style="padding-left: 20px;">LOW TIRE PRESSURE WARNING CONTROL UNIT 8</p> <p style="padding-left: 20px;">DISPLAY UNIT 8</p> <p>CAN COMMUNICATION 9</p> <p style="padding-left: 20px;">System Description 9</p> <p>TROUBLE DIAGNOSES 10</p> <p style="padding-left: 20px;">Schematic 10</p> <p style="padding-left: 20px;">Wiring Diagram 11</p> <p style="padding-left: 20px;">Control Unit Input/Output Signal Standard 14</p> <p style="padding-left: 20px;">ID Registration Procedure 14</p> <p style="padding-left: 40px;">ID REGISTRATION WITH ACTIVATION TOOL.. 14</p> <p style="padding-left: 40px;">ID REGISTRATION WITHOUT ACTIVATION TOOL 15</p> <p style="padding-left: 20px;">Transmitter Wake Up Operation 16</p> <p style="padding-left: 40px;">WITH ACTIVATION TOOL 16</p> <p style="padding-left: 20px;">Self-Diagnosis 17</p> <p style="padding-left: 40px;">DESCRIPTION 17</p> <p style="padding-left: 40px;">FUNCTION 17</p> <p style="padding-left: 20px;">LOW TIRE PRESSURE WARNING LAMP DIAG-</p>	<p style="padding-left: 20px;">NOSTIC CHART 17</p> <p style="padding-left: 20px;">CONSULT-II 19</p> <p style="padding-left: 20px;">How to Perform Trouble Diagnosis for Quick and Accurate Repair 21</p> <p style="padding-left: 40px;">INTRODUCTION 21</p> <p style="padding-left: 40px;">WORK FLOW 21</p> <p style="padding-left: 20px;">Preliminary Check 22</p> <p style="padding-left: 20px;">Malfunction Code/Symptom Chart 23</p> <p>TROUBLE DIAGNOSIS FOR SELF-DIAGNOSTIC ITEMS 24</p> <p style="padding-left: 20px;">Inspection 1: Transmitter or Low Tire Pressure Warning Control Unit 24</p> <p style="padding-left: 40px;">MALFUNCTION CODE NO. 21, 22, 23 OR 24 ... 24</p> <p style="padding-left: 20px;">Inspection 2: Transmitter - 1 24</p> <p style="padding-left: 40px;">MALFUNCTION CODE NO. 31, 32, 33, 34, 41, 42, 43, 44, 45, 46, 47 OR 48 24</p> <p style="padding-left: 20px;">Inspection 3: Transmitter - 2 25</p> <p style="padding-left: 40px;">MALFUNCTION CODE NO. 35, 36, 37 OR 38 ... 25</p> <p style="padding-left: 20px;">Inspection 4: Vehicle Speed Signal 26</p> <p style="padding-left: 40px;">MALFUNCTION CODE NO. 52 26</p> <p>TROUBLE DIAGNOSIS FOR SYMPTOMS 27</p> <p style="padding-left: 20px;">Inspection 1: Warning Lamp Does Not Come On When Ignition Switch Is Turned On. 27</p> <p style="padding-left: 20px;">Inspection 2: Warning Lamp Stays On When Ignition Switch Is Turned On. 28</p> <p style="padding-left: 20px;">Inspection 3: Warning Lamp Blinks When Ignition Switch Is Turned On. 30</p> <p style="padding-left: 20px;">Inspection 4: Hazard Warning Lamp Blinks When Ignition Switch Is Turned On. 31</p> <p style="padding-left: 20px;">Inspection 5: "TIRE PRESSURE" Information In Display Unit Does Not Exist 32</p> <p style="padding-left: 20px;">Inspection 6: ID Registration Can not Be Completed.. 32</p> <p>REMOVAL AND INSTALLATION 33</p> <p style="padding-left: 20px;">Transmitter 33</p> <p style="padding-left: 40px;">REMOVAL 33</p> <p style="padding-left: 40px;">INSTALLATION 33</p> <p>SERVICE DATA AND SPECIFICATIONS (SDS) 35</p> <p style="padding-left: 20px;">Road Wheel 35</p> <p style="padding-left: 20px;">Tire 35</p>
--	---

F

G

H

I

J

K

L

M

PREPARATION

PREPARATION

PFP:00002

Special Service Tools

AES000HA

The actual shapes of Kent-Moore tools may differ from those of special service tools illustrated here.

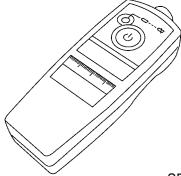
Tool number (Kent-Moore No.) Tool name	Description
(J45295) Transmitter activation tool  SEIA0462E	ID registration

Commercial Service Tools

AES000HB

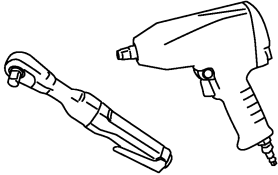
Tool name	Description
Power tool  PBIC0190E	Removing wheel nuts

NOISE, VIBRATION AND HARSHNESS (NVH) TROUBLESHOOTING

NOISE, VIBRATION AND HARSHNESS (NVH) TROUBLESHOOTING

PFP:00003

NVH Troubleshooting Chart

AES000HF

Use the chart below to help you find the cause of the symptom. If necessary, repair or replace these parts.

Reference page		FAX-5, FSU-5	WT-4	—	—	—	—	—	—	—	NVH in PR section	NVH in RFD section	NVH in FAX and FSU sections	NVH in RAX and RSU sections	Refer to TIRES in this chart	Refer to ROAD WHEEL in this chart	NVH in FAX, RAX section	NVH in BR section	NVH in PS section		
Possible cause and SUSPECTED PARTS		Improper installation, looseness	Out-of-round	Imbalance	Incorrect tire pressure	Uneven tire wear	Deformation or damage	Non-uniformity	Incorrect tire size	PROPELLER SHAFT	DIFFERENTIAL	FRONT AXLE AND FRONT SUSPENSION	REAR AXLE AND REAR SUSPENSION	TIRES	ROAD WHEEL	DRIVE SHAFT	BRAKE	STEERING			
Symptom	TIRES	Noise	x	x	x	x	x	x	x	x	x	x	x	x	x	x	x	x	x		
		Shake	x	x	x	x	x	x	x	x	x	x	x	x	x	x	x	x	x	x	
		Vibration				x				x	x		x	x		x			x	x	
		Shimmy	x	x	x	x	x	x	x	x			x	x	x	x		x	x	x	
		Judder	x	x	x	x	x	x		x			x	x		x		x	x	x	x
		Poor quality ride or handling	x	x	x	x	x	x		x			x	x		x					
	ROAD WHEEL	Noise	x	x	x			x			x	x	x	x	x		x	x	x	x	
		Shake	x	x	x			x			x		x	x	x		x	x	x	x	
Shimmy, judder		x	x	x			x					x	x	x			x	x	x		
Poor quality ride or handling		x	x	x			x					x	x	x							

x: Applicable

A
B
C
D
WT
F
G
H
I
J
K
L
M

ROAD WHEEL

PFP:40300

AES000HC

ROAD WHEEL

Inspection ALUMINUM WHEEL

1. Check tires for wear and improper inflation.
2. Check wheels for deformation, cracks and other damage. If deformed, remove wheel and check wheel runout.
 - a. Remove tire from aluminum wheel and mount on a tire balance machine.
 - b. Set dial indicator as shown in the figure.

Wheel runout (Dial indicator value):

Refer to WT-35, "SERVICE DATA AND SPECIFICATIONS (SDS)"

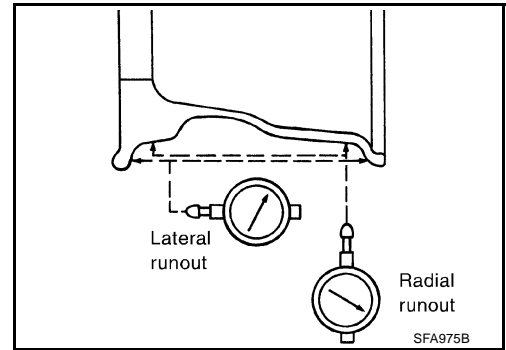

STEEL WHEEL

1. Check tires for wear and improper inflation.
2. Check wheels for deformation, cracks and other damage. If deformed, remove wheel and check wheel runout.
 - a. Remove tire from steel wheel and mount wheel on a tire balance machine.
 - b. Set two dial indicators as shown in the figure.
 - c. Set each dial indicator to 0.
 - d. Rotate wheel and check dial indicators at several points around the circumference of the wheel.
 - e. Calculate runout at each point as shown below.

$$\text{Radial runout} = (A+B)/2$$

$$\text{Lateral runout} = (C+D)/2$$

- f. Select maximum positive runout value and the maximum negative value. Add the two values to determine total runout. In case a positive or negative value is not available, use the maximum value (negative or positive) for total runout. If the total runout value exceeds the limit, replace steel wheel.

Wheel runout : Refer to WT-35, "SERVICE DATA AND SPECIFICATIONS (SDS)"

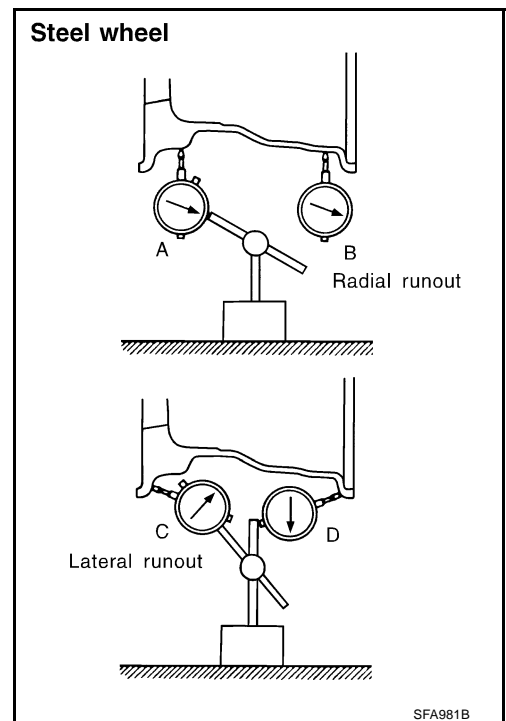

ROAD WHEEL TIRE ASSEMBLY

ROAD WHEEL TIRE ASSEMBLY

PPF:40300

Balancing Wheels (Bonding Weight Type) REMOVAL

AES000HD

1. Remove inner and outer balance weights from the road wheel.

CAUTION:

Be careful not to scratch the road wheel during removal.

2. Using releasing agent, remove double-faced adhesive tape from the road wheel.

CAUTION:

- **Be careful not to scratch the road wheel during removal.**
- **After removing double-faced adhesive tape, wipe clean traces of releasing agent from the road wheel.**

WHEEL BALANCE ADJUSTMENT

- If a tire balance machine has adhesion balance weight mode settings and drive-in weight mode setting, select and adjust a drive-in weight mode suitable for road wheels.

1. Set road wheel on wheel balancer using the center hole as a guide. Start the tire balance machine.
2. When inner and outer unbalance values are shown on the wheel balancer indicator, multiply outer unbalance value by $5/3$ to determine balance weight that should be used. Select the outer balance weight with a value closest to the calculated value above and install it to the designated outer position of, or at the designated angle in relation to the road wheel.

CAUTION:

- **Do not install the inner balance weight before installing the outer balance weight.**
- **Before installing the balance weight, be sure to clean the mating surface of the road wheel.**

Indicated unbalance value $\times 5/3$ = balance weight to be installed

Calculation example:

$23 \text{ g (0.81 oz)} \times 5/3 = 38.33 \text{ g (1.35 oz)} = 40 \text{ g (1.41 oz)}$ balance weight (closer to calculated balance weight value)

Note that balance weight value must be closer to the calculated balance weight value.

Example:

$37.4 = 35 \text{ g (1.23 oz)}$

$37.5 = 40 \text{ g (1.41 oz)}$

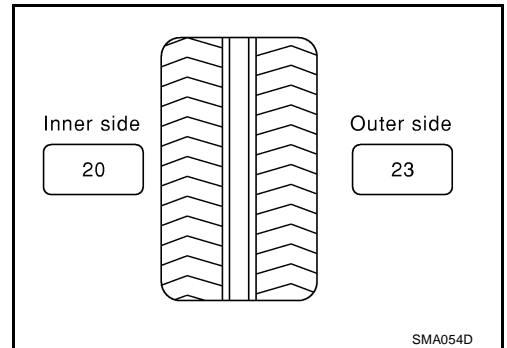

- a. Install balance weight in the position shown in the figure.
- b. When installing balance weight to road wheels, set it into the grooved area on the inner wall of the road wheel as shown in the figure so that the balance weight center is aligned with the wheel balancer indication position (angle).

CAUTION:

- **Always use genuine Nissan adhesion balance weights.**
- **Balance weights are un reusable; always replace with new ones.**
- **Do not install more than three pieces of balance weight.**

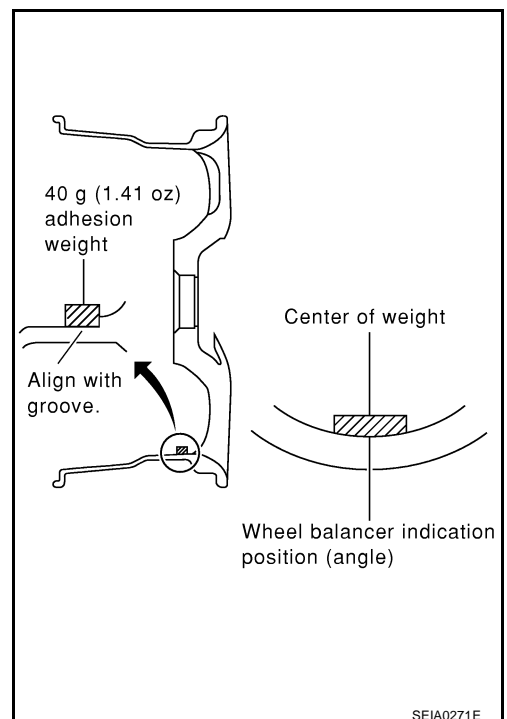

ROAD WHEEL TIRE ASSEMBLY

- c. If calculated balance weight value exceeds 50 g (1.76 oz), install two balance weight pieces in line with each other (as shown in the figure).

CAUTION:

Do not install one balance weight piece on top of another.

3. Start wheel balancer again.
 4. Install drive-in balance weight on inner side of road wheel in the wheel balancer indication position (angle).

CAUTION:

Do not install more than two balance weights.

5. Start wheel balancer. Make sure that inner and outer residual unbalance values are 10 g (0.35 oz) each or below.
- If either residual unbalance value exceeds 10 g (0.35 oz), repeat installation procedures.

Wheel balance (Maximum allowable unbalance):

Maximum allowable unbalance	Dynamic (At rim flange)	10 g (0.35 oz) (one side)
	Static (At rim flange)	20 g (0.71 oz)

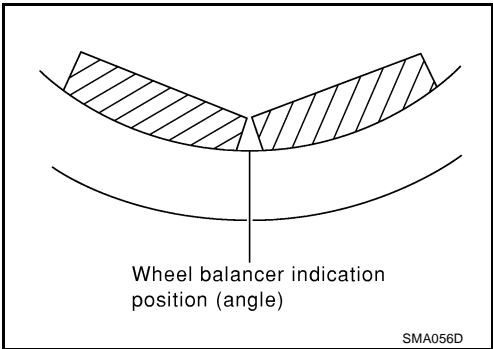

Rotation

- After rotating the tires, adjust the tire pressure.
- Retighten the wheel nuts when the vehicle has been driven for 1,000 km (600 miles) (also in cases of a flat tire, etc.).

CAUTION:

When installing wheels, tighten them diagonally by dividing the work two to three times in order to prevent the wheels from developing any distortion.

Tightening torque of wheel nut:

98.1 - 127 N·m (10 - 12 kg·m, 73 - 93 ft·lb)

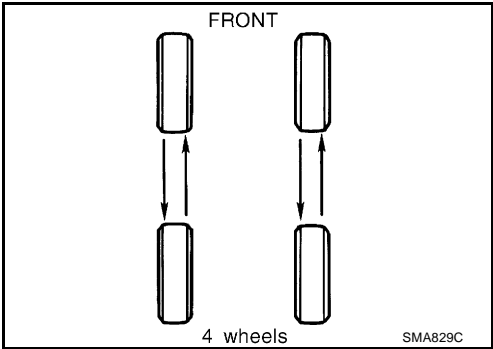

AES000MY

LOW TIRE PRESSURE WARNING SYSTEM

LOW TIRE PRESSURE WARNING SYSTEM

PFP:40300

System Components

AES000HG

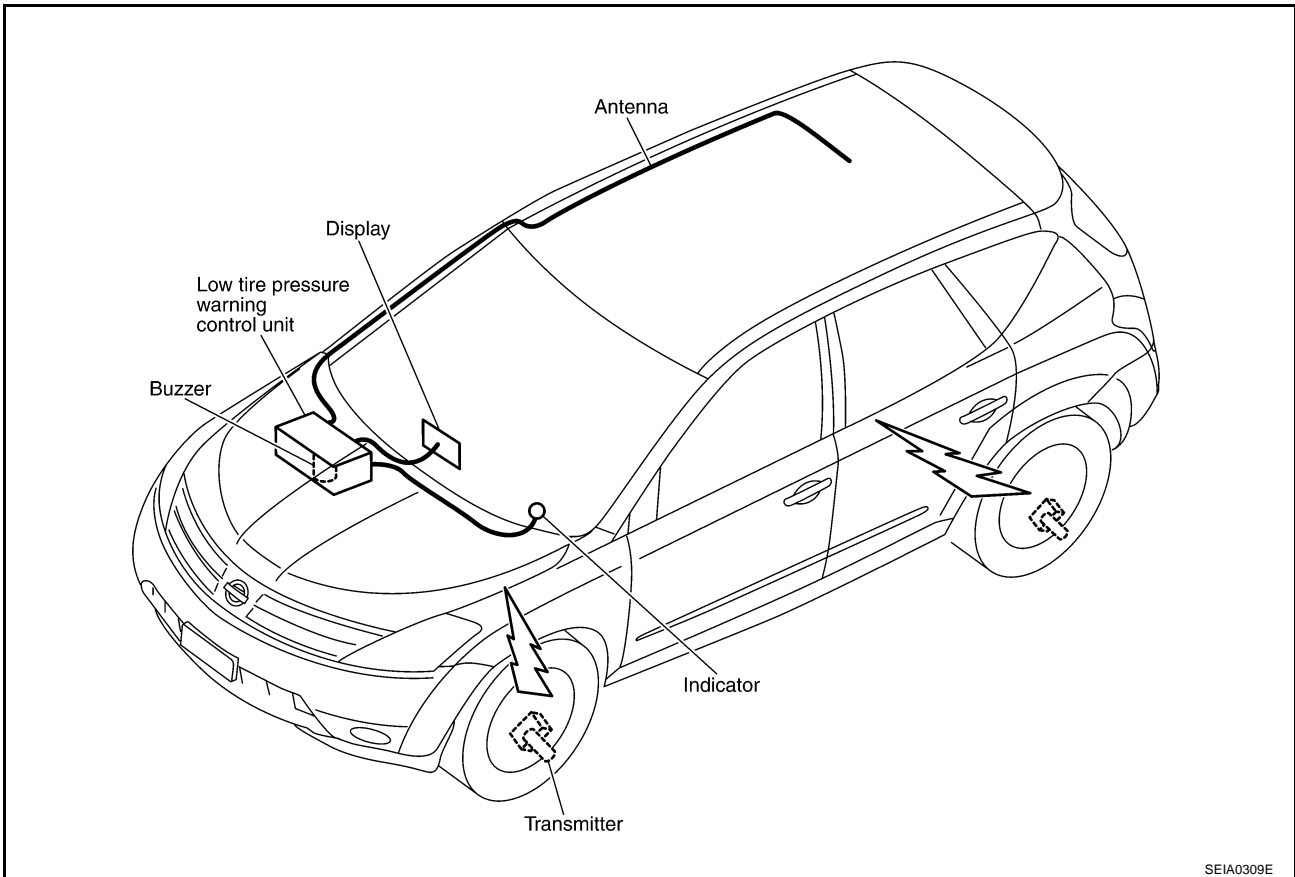

A
B
C
D
WT
F
G
H
I
J
K
L
M

System Description TRANSMITTER

AES000HH

A sensor-transmitter integrated with a valve is installed on a wheel, and transmits a detected air pressure signal in the form of a radio wave.

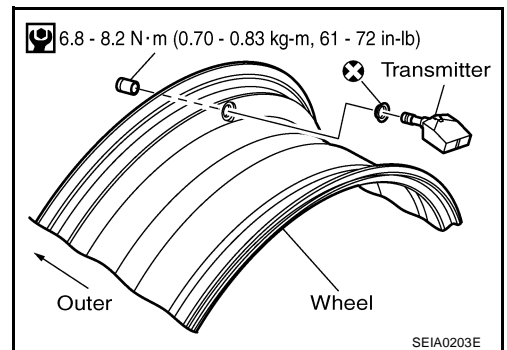

LOW TIRE PRESSURE WARNING SYSTEM

ANTENNA

Receives the radio wave signal transmitted by the transmitter.

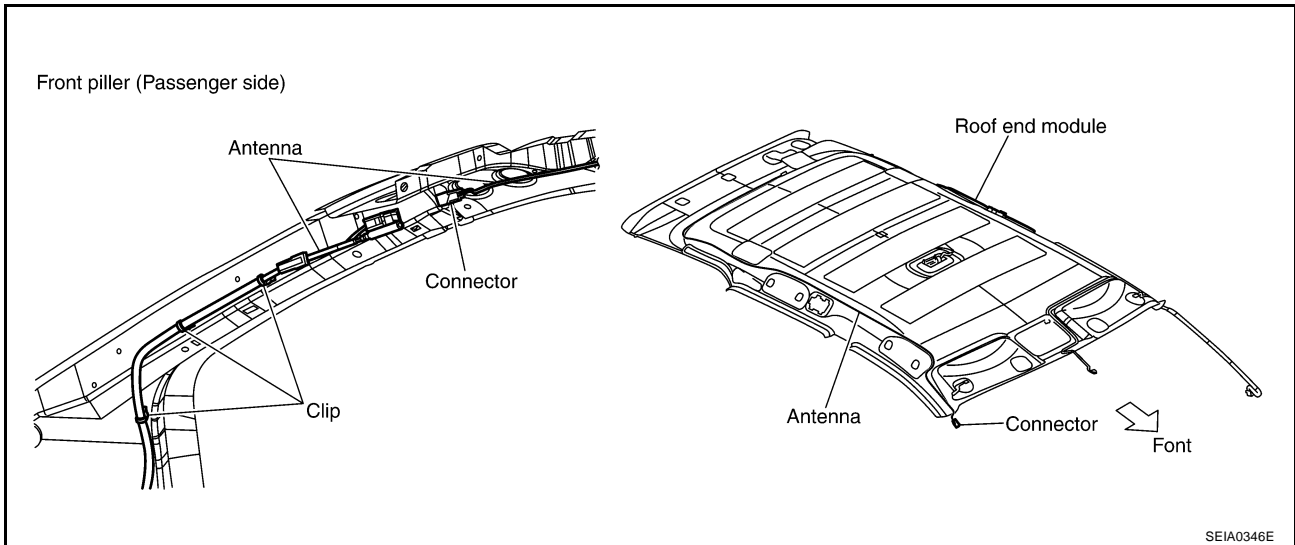

LOW TIRE PRESSURE WARNING CONTROL UNIT

Reads the radio wave signal received by the antenna, and controls the warning lamp and the buzzer operations as shown below. It also has a judgement function to detect a system malfunction.

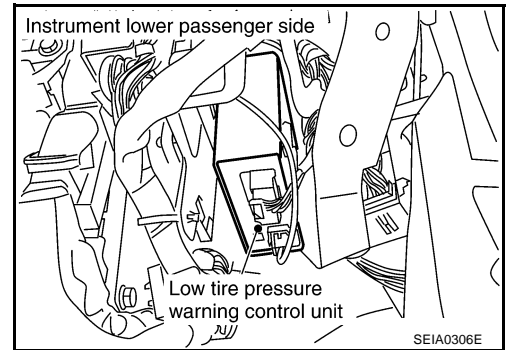

Condition	Warning lamp	Buzzer
Less than 190 kPa (1.9 kg/cm ² , 27 psi) [Flat tire]	ON	Sounds for 10 sec.
System malfunction	ON	OFF

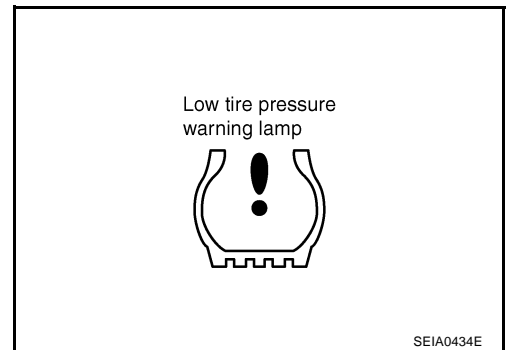

DISPLAY UNIT

Displays the air pressure of each tire.

- After the ignition switch is turned ON, the pressure values are not be displayed until the data of each wheel stabilizes.

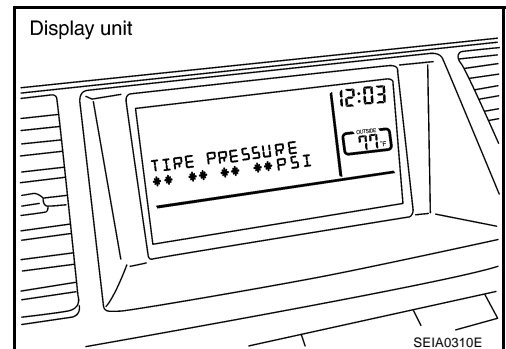

CAN COMMUNICATION

PFP:23710

System Description

AES0000J

CAN (Controller Area Network) is a serial communication line for real time application. It is an on-vehicle multiplex communication line with high data communication speed and excellent error detection ability. Many electronic control units are equipped onto a vehicle, and each control unit shares information and links with other control units during operation (not independent). In CAN communication, control units are connected with 2 communication lines (CAN H line, CAN L line) allowing a high rate of information transmission with less wiring. Each control unit transmits/receives data but selectively reads required data only.

Refer to [LAN-29, "CAN COMMUNICATION"](#) .

A
B
C
D

WT

F
G
H
I
J
K
L
M

TROUBLE DIAGNOSES

TROUBLE DIAGNOSES

PF0:00004

Schematic

AES000HK

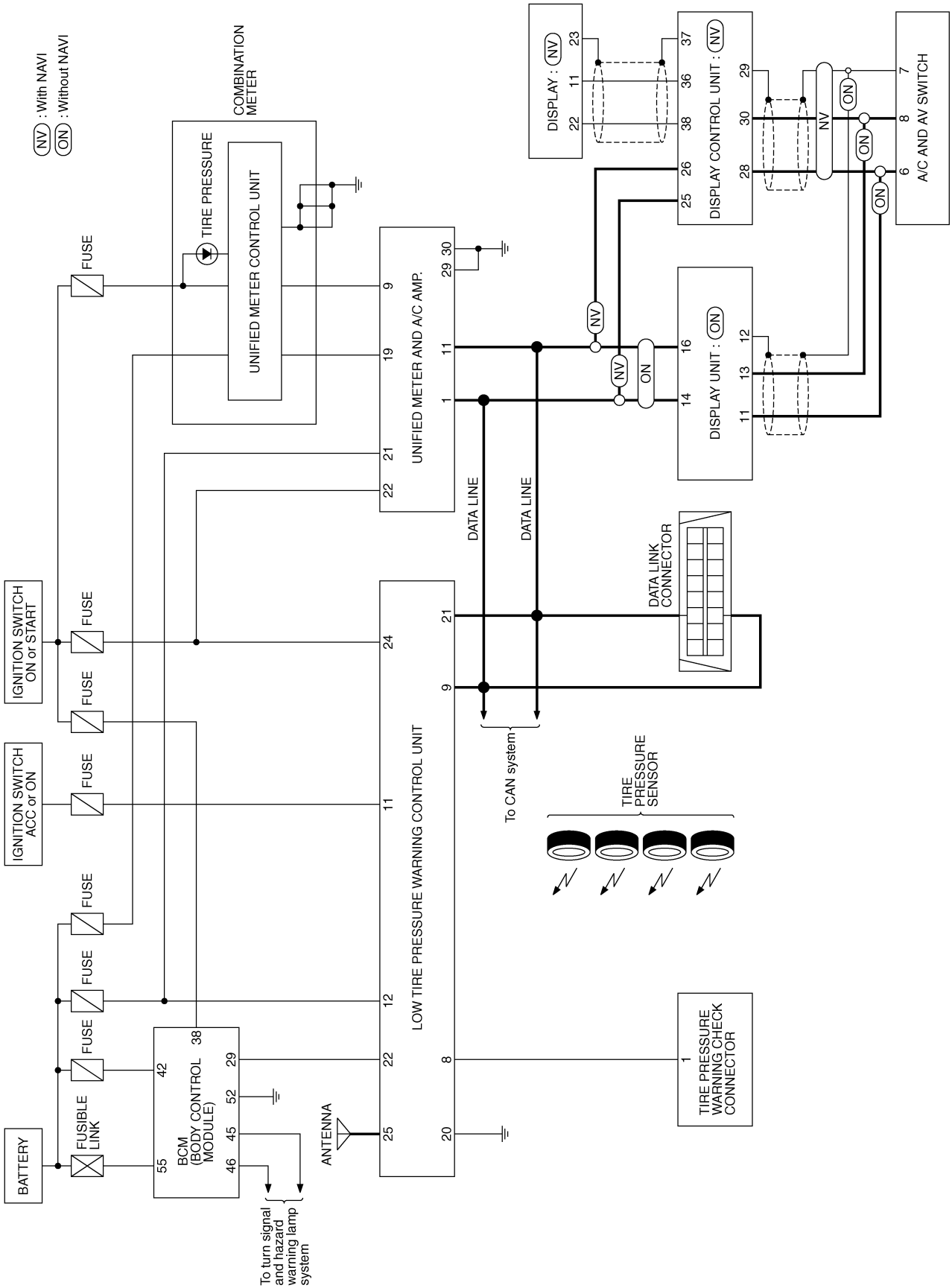

TEWB0001E

TROUBLE DIAGNOSES

Wiring Diagram

AES000HL

WT-T/WARN-01

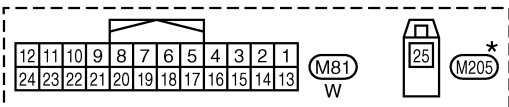
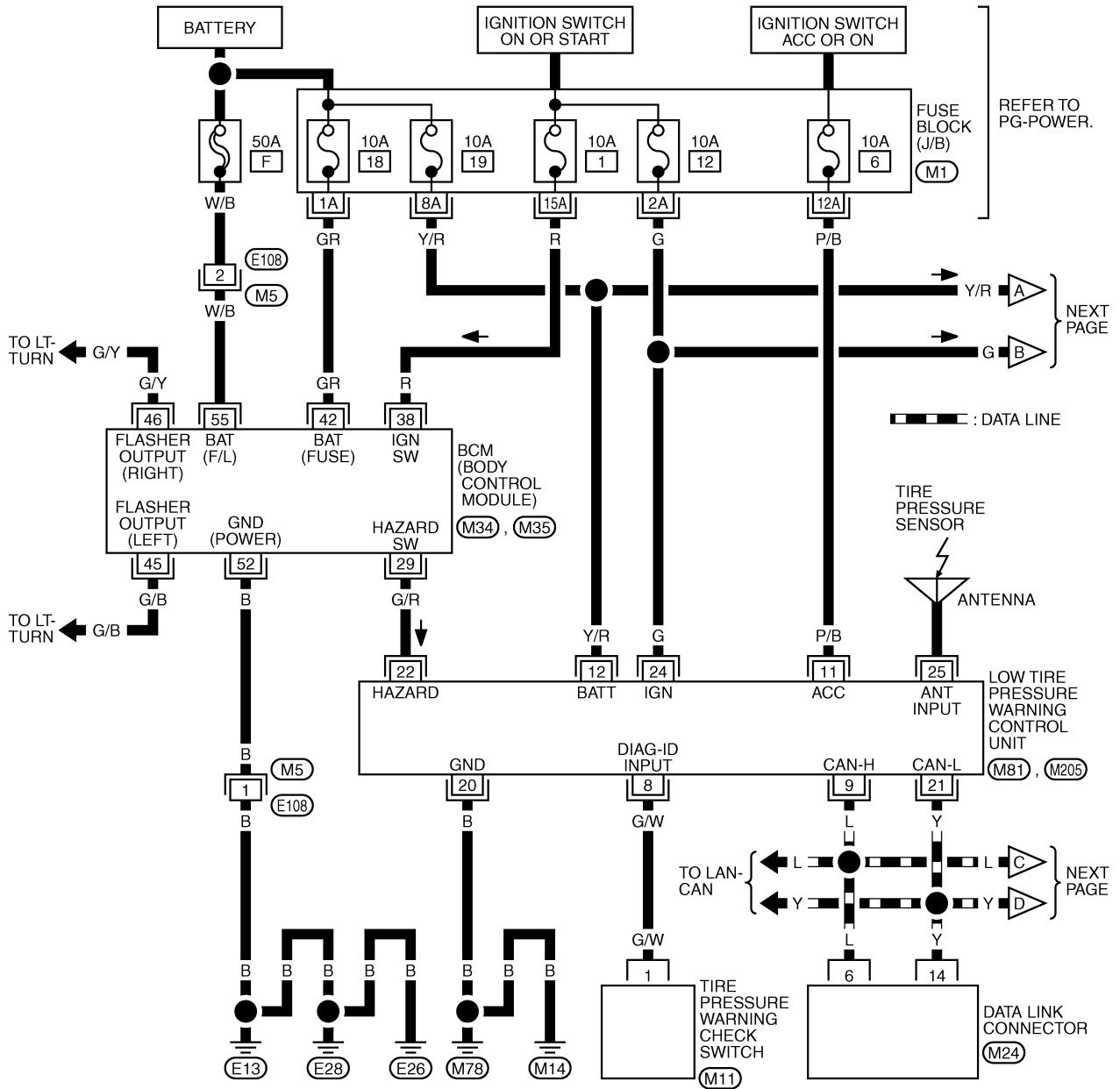

*: THIS CONNECTOR IS NOT SHOWN IN "HARNESS LAYOUT", PG SECTION.

REFER TO THE FOLLOWING.

- (M1) - FUSE BLOCK-JUNCTION BOX (J/B)
- (M34), (M35) - ELECTRICAL UNITS

TEWB0002E

TROUBLE DIAGNOSES

WT-T/WARN-02

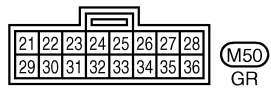
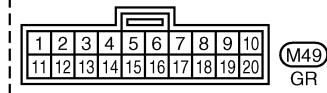
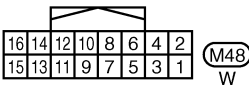
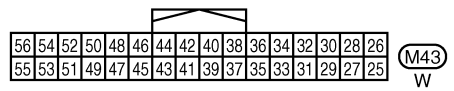
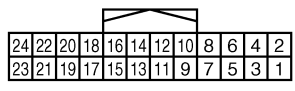
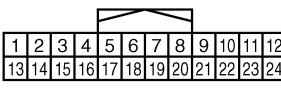
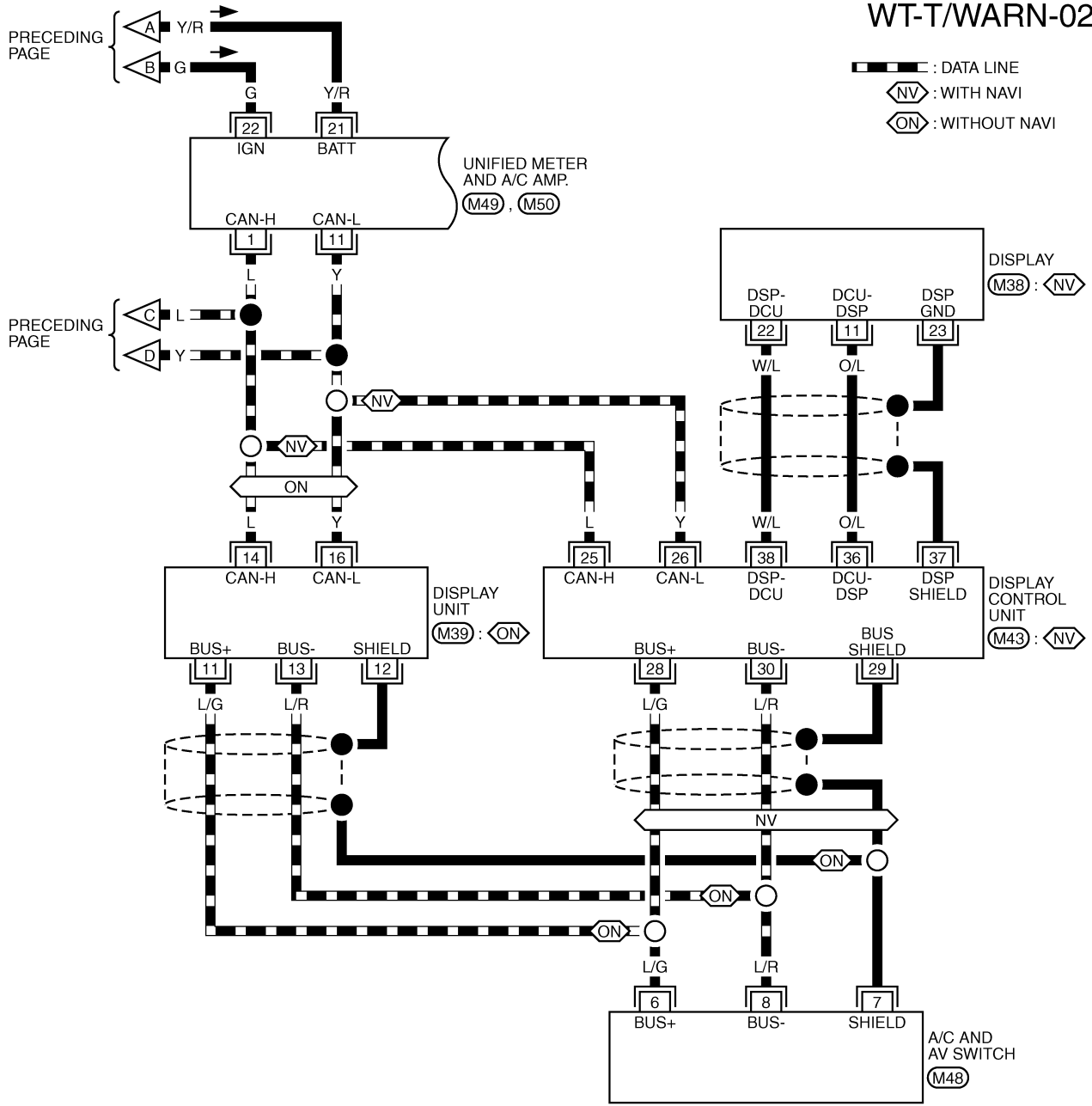

TEWA0019E

TROUBLE DIAGNOSES

WT-T/WARN-03

A
B
C
D
WT
F
G
H
I
J
K
L
M

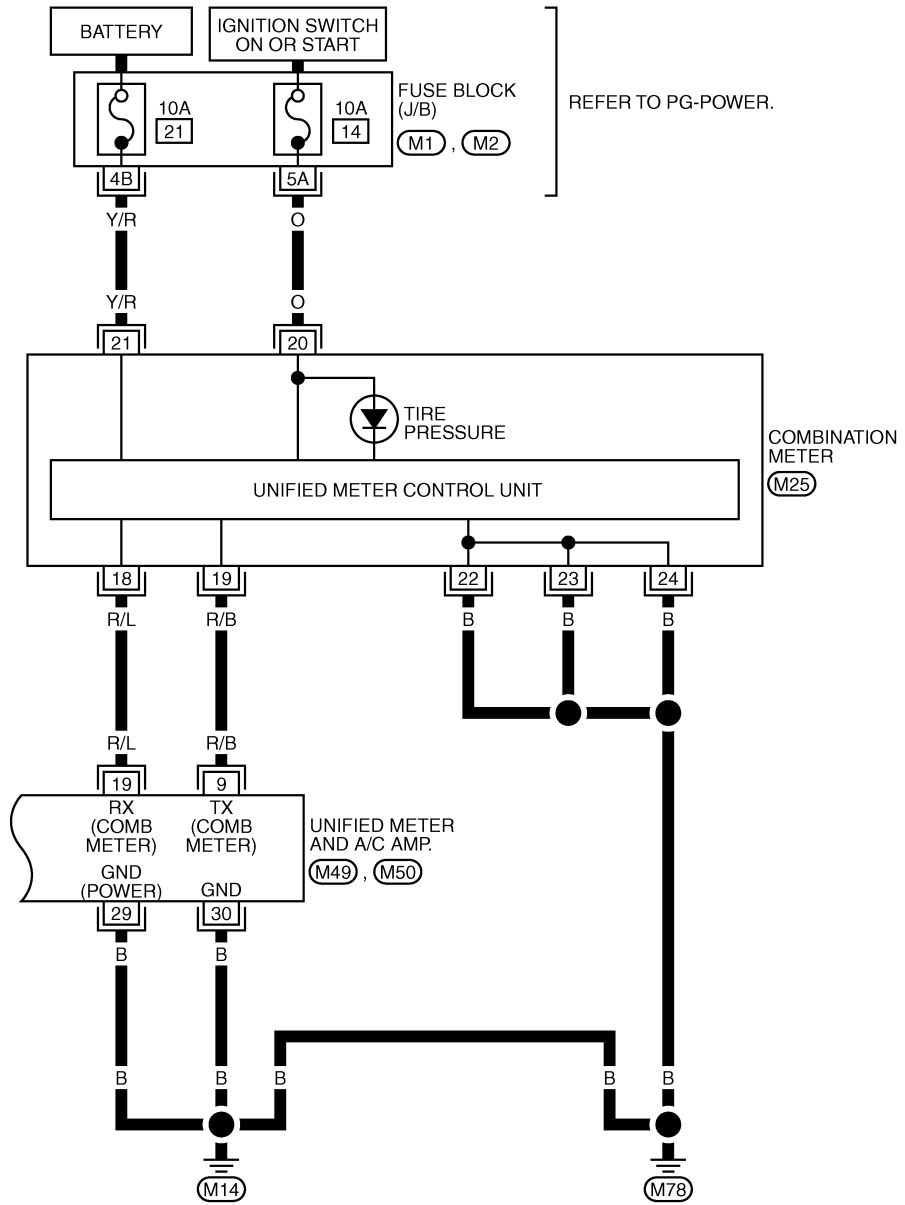

REFER TO PG-POWER.

COMBINATION METER (M25)

UNIFIED METER AND A/C AMP. (M49, M50)

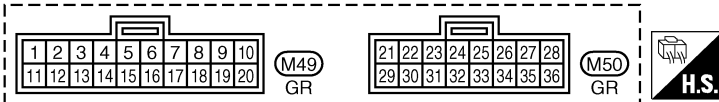
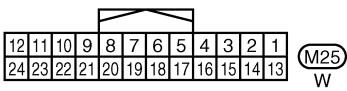

REFER TO THE FOLLOWING.
(M1), (M2) - FUSE BLOCK-JUNCTION BOX (J/B)

TEWA0020E

TROUBLE DIAGNOSES

Control Unit Input/Output Signal Standard

AES000HM

Standards using a circuit tester and oscilloscope

Measurement terminal		Measuring point	Standard value		
+	-				
8 (G/W)	Ground	Tire pressure warning check switch	Always	Approx. 5V	
9 (L)		Data line (CAN H)	—	—	
11 (P/B)		Ignition switch ON or ACC	Ignition switch ON	Battery voltage (Approx. 12 V)	
12 (Y/R)		Battery power supply	Always	Battery voltage (Approx. 12 V)	
20 (B)		GND	—	Approx. 0 V	
21 (Y)		Data line (CAN L)	—	—	
22 (G/R)		Hazard	Hazard lamp switch OFF		Battery voltage (Approx. 12 V)
			Hazard lamp switch ON		Approx. 0 V
24 (G)		Ignition switch ON or START		Battery voltage (Approx. 12 V)	
25		Antenna	—	—	

() : Wire color

ID Registration Procedure ID REGISTRATION WITH ACTIVATION TOOL

AES000HN

This procedure must do after replacing transmitter or low tire pressure warning control unit.

1. Turn ignition switch "OFF".
2. Connect CONSULT-II and CONSULT-II CONVERTER to data link connector.
3. Touch "AIR PRESSURE MONITOR", "WORK SUPPORT" and "ID REGIST".

NOTE:

If "AIR PRESSURE MONITOR" is not indicated, go to [GI-39, "CONSULT-II Data Link Connector \(DLC\) Circuit"](#).

4. With the activation tool (J-45295) pushed against the front-left transmitter position of the tire air valve, press and hold the button for 5 seconds.

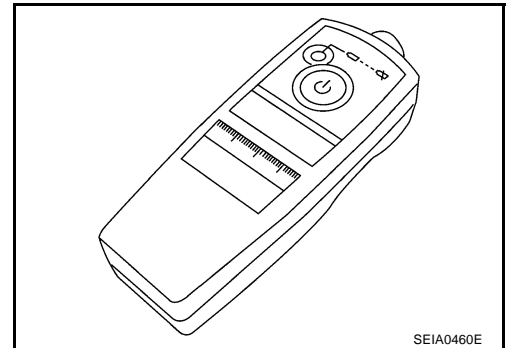

5. Register the IDs in order from FR LH, FR RH, RR RH or RR LH. When ID registration of each wheel has been completed, a buzzer sounds and hazard warning lamp blinks.

Activation tire position	Buzzer	Hazard warning lamp	CONSULT-II
1 Front LH	Once	2 times flashing	"YET" ↓ "DONE"
2 Front RH	2 times		
3 Rear LH	3 times		
4 Rear RH	4 times		

6. After completing all ID registrations, press "END" to complete the procedure.

NOTE:

Be sure to register the IDs in order from FR LH, FR RH, RR RH, to RR LH, or the self-diagnostic results display will not function properly.

TROUBLE DIAGNOSES

ID REGISTRATION WITHOUT ACTIVATION TOOL

1. Turn ignition switch "OFF".
2. Connect CONSULT-II and CONSULT-II CONVERTER to data link connector.
3. Touch "AIR PRESSURE MONITOR", "WORK SUPPORT" and "ID REGIST".

NOTE:

If "AIR PRESSURE MONITOR" is not indicated, go to [GI-39, "CONSULT-II Data Link Connector \(DLC\) Circuit"](#) .

4. Adjust the tire pressure to the values shown in the table below for ID registration, and drive the vehicle at 40 km/h (25 MPH) or more for a few minutes.

Tire position	Tire pressure kPa (kg/cm ² , psi)
Front – Left	250 (2.5, 36)
Front – Right	230 (2.3, 33)
Rear – Right	210 (2.1, 30)
Rear – Left	190 (1.9, 27)

5. After completing all ID registrations, press "END" to complete the procedure.

Activation tire position	CONSULT-II
Front LH	"YET" ↓ "DONE"
Front RH	
Rear LH	
Rear RH	

A
B
C
D
WT
F
G
H
I
J
K
L
M

TROUBLE DIAGNOSES

AES000HO

Transmitter Wake Up Operation WITH ACTIVATION TOOL

1. With the activation tool (J-45295) pushed against the front-left transmitter, press and hold the button for 5 seconds.
 - When ignition switch ON, then warning lamp is blinks as follow diagram transmitter must be waken up.

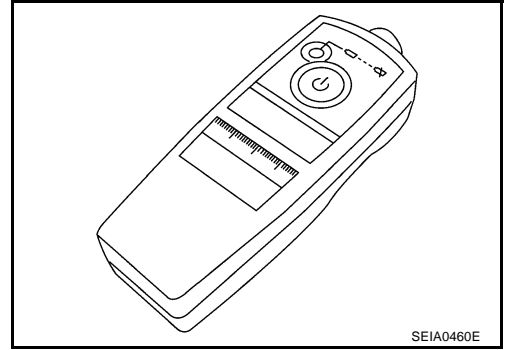

2. Register the ID of wheel that warning lamp flashes. When wake up of registered wheel has been completed, a hazard warning lamp blinks.

	Warning lamp blinking timing	Need to activation tire position	Hazard warning lamp
1	ON OFF	a : 0.3sec b : 1.3sec	2 time flashing
2	ON OFF	a : 0.3sec b : 1.3sec	
3	ON OFF	a : 0.3sec b : 1.3sec	
4	ON OFF	a : 0.3sec b : 1.3sec	
5	ON OFF	a : 2sec b : 0.2sec	

SEIA0351E

3. After completing wake up of all transmitters, make sure tire pressure warning lamp go out.

TROUBLE DIAGNOSES

AES000HP











Self-Diagnosis DESCRIPTION

During driving, the low tire pressure warning system receives the signal transmitted from the transmitter installed in each wheel, and gives alarms when the tire pressure becomes low. The control unit of this system has pressure judgement and trouble diagnosis functions.



FUNCTION

When the low tire pressure warning system detects low inflation pressure or another unusual symptom, the warning lamps in the combination meter comes on. To start the self-diagnostic results mode, ground the self-diagnostic (check) terminal. The malfunction location is indicated by the warning lamp flashing and the buzzer sounds.

LOW TIRE PRESSURE WARNING LAMP DIAGNOSTIC CHART

Diagnosis Item	Symptom (Ignition switch ON)	Low tire pressure warning lamp	Cause	Action
Low tire pressure warning lamp	Warning light comes on immediately and turns off after 1 second	  ON 1 sec > stays OFF <small>SEIA0592E</small>	All wheel transmitters are "activated" (working)	None (system OK)
	Warning light blinks on for 2 seconds, then turns off for 0.2 seconds-repeats	 Blinks:  ON 2 sec > OFF 0.2 sec <small>SEIA0593E</small>	All wheel transmitters are not activated	Activate all wheel transmitters. Refer to WT-16, "Transmitter Wake Up Operation" .
	Warning light blinks 1 time	 Blinks 1 time ON 0.3 sec > OFF 1.3 sec <small>SEIA0594E</small>	Front LH wheel transmitter is not activated	Activate front LH wheel transmitter. Refer to WT-16, "Transmitter Wake Up Operation" .
	Warning light blinks 2 times	  Blinks 2 times ON 0.3 sec > OFF 0.3 sec <small>SEIA0595E</small>	Front RH wheel transmitter is not activated	Activate front RH wheel transmitter. Refer to WT-16, "Transmitter Wake Up Operation" .
	Warning light blinks 3 times	   Blinks 3 times ON 0.3 sec > OFF 0.3 sec <small>SEIA0596E</small>	Rear RH wheel transmitter is not activated	Activate rear RH wheel transmitter. Refer to WT-16, "Transmitter Wake Up Operation" .

TROUBLE DIAGNOSES

Diagnosis Item	Symptom (Ignition switch ON)	Low tire pressure warning lamp	Cause	Action
Low tire pressure warning lamp	Warning light blinks 4 times	 Blinks 4 times ON 0.3 sec > OFF 0.3 sec <small>SEIA0597E</small>	Rear LH wheel transmitter is not activated	Activate rear LH wheel transmitter. Refer to WT-16, "Transmitter Wake Up Operation" .
	Warning light comes on and does not turn off	 Comes ON and stays ON <small>SEIA0598E</small>	The fuse for combination meter from battery is pulled out	Check the fuse for combination meter from battery. Install or replace (if needed).
			C/U connector pulled out	Check C/U connector. Re-connect if needed.
Turn signal lamp	Turn signal lamp does not flash 2 times or horn does not sound after transmitter activation.		Low tire pressure or low tire pressure warning system failure	<ul style="list-style-type: none"> ● Perform CONSULT-II Self Diagnosis. Refer to WT-17, "Self-Diagnosis". – Perform ID Registration if needed. Refer to WT-14, "ID Registration Procedure".
			<ol style="list-style-type: none"> 1. Tool J-45295 (special service tool) battery low. 2. Ignition OFF during activation. 3. Tool J-45295 (special service tool) not positioned correctly. 4. Transmitters already activated. 	<ol style="list-style-type: none"> 1. Install new battery. 2. Make sure ignition is ON during activation. 3. Position tool correctly during activation. 4. None

NOTE:

If more than one wheel transmitter is NOT activated, the warning light blinking patterns for those wheels will combine. (Example: one blink/OFF/three blinks = Rear LH and Rear RH transmitters are not activated.)

TROUBLE DIAGNOSES

CONSULT-II

CONSULT-II Main Function

In a diagnosis function (main function), there are "WORK SUPPORT", "SELF-DIAGNOSTIC RESULTS", "DATA MONITOR", "CAN DIAG SUPPORT MNTR".

Diagnostic test mode	Function
WORK SUPPORT	This mode enables a technician to adjust some devices faster and more accurately by following the indications on CONSULT-II.
SELF-DIAGNOSTIC RESULTS	Self-diagnostic results can be read and erased quickly.
DATA MONITOR	Input/Output data in the control unit can be read.
CAN DIAG SUPPORT MNTR	The results of transmit/receive diagnosis of communication can be read.

CONSULT-II Application to Low Tire Pressure Warning System

ITEM	SELF-DIAGNOSTIC RESULTS	DATA MONITOR
Front - Left transmitter	×	×
Front - Right transmitter	×	×
Rear - Left transmitter	×	×
Rear - Right transmitter	×	×
Warning lamp	—	×
Vehicle speed	×	×
Buzzer (in control unit)	—	×
CAN Communication	×	×

× : Applicable

— : Not applicable

Self-Diagnostic Results Mode

Diagnostic item	Diagnostic item is detected when ...
FLAT - TIRE - FL FLAT - TIRE - FR FLAT - TIRE - RR FLAT - TIRE - RL	Front-left tire pressure drops to 190 kPa (1.9 kg/cm ² , 27 psi) or less. Front-right tire pressure drops to 190 kPa (1.9 kg/cm ² , 27 psi) or less. Rear-right tire pressure drops to 190 kPa (1.9 kg/cm ² , 27 psi) or less. Rear-left tire pressure drops to 190 kPa (1.9 kg/cm ² , 27 psi) or less.
[NO-DATA] - FL [NO-DATA] - FR [NO-DATA] - RR [NO-DATA] - RL	Data from front-left transmitter can not be received. Data from front-right transmitter can not be received. Data from rear-right transmitter can not be received. Data from rear-left transmitter can not be received.
[CHECKSUM- ERR] - FL [CHECKSUM- ERR] - FR [CHECKSUM- ERR] - RR [CHECKSUM- ERR] - RL	Checksum data from front-left transmitter is malfunctioning. Checksum data from front-right transmitter is malfunctioning. Checksum data from rear-right transmitter is malfunctioning. Checksum data from rear-left transmitter is malfunctioning.
[PRESSDATA- ERR] - FL [PRESSDATA- ERR] - FR [PRESSDATA- ERR] - RR [PRESSDATA- ERR] - RL	Air pressure data from front-left transmitter is malfunctioning. Air pressure data from front-right transmitter is malfunctioning. Air pressure data from rear-right transmitter is malfunctioning. Air pressure data from rear-left transmitter is malfunctioning.
[CODE- ERR] - FL [CODE- ERR] - FR [CODE- ERR] - RR [CODE- ERR] - RL	Function code data from front-left transmitter is malfunctioning. Function code data from front-right transmitter is malfunctioning. Function code data from rear-right transmitter is malfunctioning. Function code data from rear-left transmitter is malfunctioning.
[BATT - VOLT - LOW] - FL [BATT - VOLT - LOW] - FR [BATT - VOLT - LOW] - RR [BATT - VOLT - LOW] - RL	Battery voltage of front-left transmitter drops. Battery voltage of front-right transmitter drops. Battery voltage of rear-right transmitter drops. Battery voltage of rear-left transmitter drops.
VHCL_SPEED_SIG_ERR	Vehicle speed signal is error.

NOTE:

Before performing the self-diagnosis, be sure to register the ID, or else the actual malfunction location may be different from that displayed on CONSULT-II.

TROUBLE DIAGNOSES

Data Monitor Mode

MONITOR	CONDITION	SPECIFICATION
VHCL SPEED SE	Drive vehicle.	Vehicle speed (km/h or MPH)
AIR PRESS FL AIR PRESS FR AIR PRESS RR AIR PRESS RL	<ul style="list-style-type: none"> ● Drive vehicle for a few minutes. <li style="text-align: center;">or ● Ignition switch ON and activation tool is transmitting activation signals. 	Tire pressure (kPa or psi)
ID REGST FL ID REGST FR ID REGST RR ID REGST RL	Ignition switch ON	Registration ID: DONE No registration ID: YET
WARNING LAMP		Warning lamp on: ON Warning lamp off: OFF
BUZZER		Buzzer in Low tire pressure warning control unit on: ON Buzzer in Low tire pressure warning control unit off: OFF

NOTE:

Before performing the self-diagnosis, be sure to register the ID, or else the actual malfunction location may be different from that displayed on CONSULT-II.

TROUBLE DIAGNOSES

How to Perform Trouble Diagnosis for Quick and Accurate Repair

AES000HQ

INTRODUCTION

- Before troubleshooting, verify customer complaints.
- If a vehicle malfunction is difficult to reproduce, harnesses, harness connectors or terminals may be malfunctioning. Hold and shake these parts to make sure they are securely connected.
- When using a circuit tester to measure voltage or resistance of each circuit, be careful not to expand connector terminals.

WORK FLOW

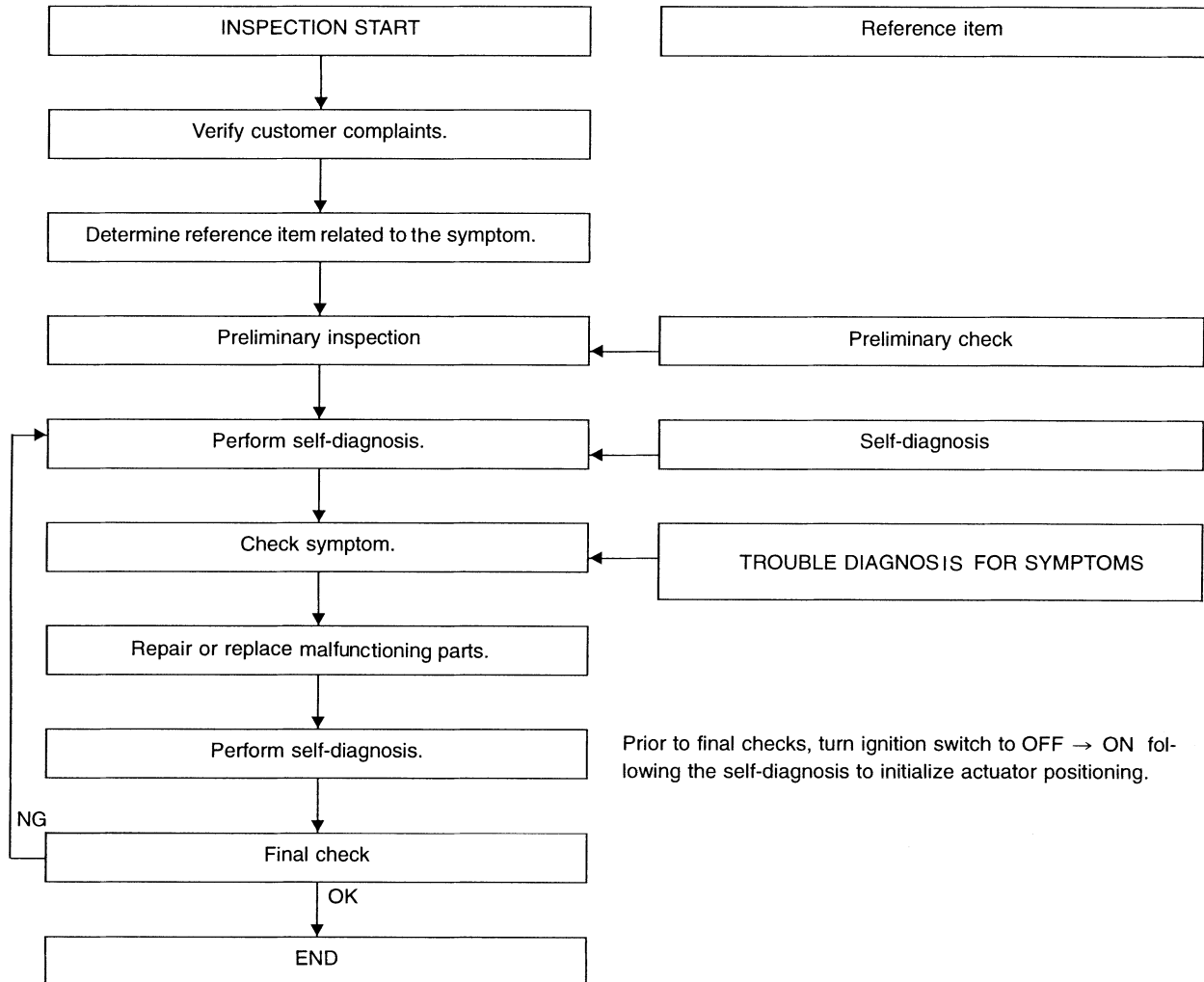

Preliminary check : [WT-22](#)

Self-diagnosis : [WT-17](#)

Trouble diagnosis for symptoms : [WT-27](#)

SEIA0100E

TROUBLE DIAGNOSES

AES000HR

Preliminary Check

BASIC INSPECTION

1. CHECK ALL TIRE PRESSURES

- Check all tire pressures.

Tire pressure : 230 kPa (2.3 kg/cm² , 33 psi)

OK or NG

OK >> GO TO 2.

NG >> Adjust tire pressure to specified value.

2. CHECK WARNING LAMP ACTIVATION

1. Check warning lamp activation.
2. Does warning lamp activate for 1 second when ignition switch is turned "ON".

Does warning lamp activate?

YES >> GO TO 3.

NO >> Check fuse and combination meter.

3. CHECK CONNECTOR

1. Disconnect low tire pressure warning control unit harness connectors M81 and M205.
2. Check terminals for damage or loose connection.
3. Reconnect harness connector.

OK or NG

OK >> GO TO 4.

NG >> Repair or replace damaged parts.

4. CHECK ACTIVATION TOOL

- Check activation tool battery.

OK or NG

OK >> Perform self-diagnosis.

NG >> Replace activation tool battery.

TROUBLE DIAGNOSES

Malfunction Code/Symptom Chart

AES000HS

Code/Symptom	Malfunction part	Reference page
15 16 17 18	Front-left tire pressure drops to 190 kPa (1.9 kg/cm ² , 27 psi) or less. Front-right tire pressure drops to 190 kPa (1.9 kg/cm ² , 27 psi) or less. Rear-right tire pressure drops to 190 kPa (1.9 kg/cm ² , 27 psi) or less. Rear-left tire pressure drops to 190 kPa (1.9 kg/cm ² , 27 psi) or less.	—
21 22 23 24	Transmitter no data (front - left) Transmitter no data (front - right) Transmitter no data (rear - right) Transmitter no data (rear - left)	WT-24
31 32 33 34	Transmitter checksum error (front - left) Transmitter checksum error (front - right) Transmitter checksum error (rear - right) Transmitter checksum error (rear - left)	WT-24
35 36 37 38	Transmitter pressure data error (front - left) Transmitter pressure data error (front - right) Transmitter pressure data error (rear - right) Transmitter pressure data error (rear - left)	WT-24
41 42 43 44	Transmitter function code error (front - left) Transmitter function code error (front - right) Transmitter function code error (rear - right) Transmitter function code error (rear - left)	WT-24
45 46 47 48	Transmitter battery voltage low (front - left) Transmitter battery voltage low (front - right) Transmitter battery voltage low (rear - right) Transmitter battery voltage low (rear - left)	WT-24
52	Vehicle speed signal	WT-26
Warning lamp does not come on when ignition switch is turned on.	Fuse or unified meter and A/C amp. Low tire pressure warning control unit connector or circuit Low tire pressure warning control unit	WT-27
Warning lamp stays on when ignition switch is turned on.	Fuse or unified meter and A/C amp. Low tire pressure warning control unit connector or circuit Low tire pressure warning control unit	WT-28
Warning lamp blinks when ignition switch is turned on.	Low tire pressure warning control unit harness connector or circuit Low tire pressure warning control unit Transmitter's mode off ID registration not yet	WT-30
Hazard warning lamp blinks when ignition switch is turned on.	Low tire pressure warning control unit harness connector or circuit Low tire pressure warning control unit	WT-31
"TIRE PRESSURE" information in display does not exist.	Fuse Display unit Low tire pressure warning control unit	WT-32
ID registration can not be completed.	Transmitter Antenna harness connector or circuit Antenna	WT-32

A
B
C
D
WT
F
G
H
I
J
K
L
M

TROUBLE DIAGNOSIS FOR SELF-DIAGNOSTIC ITEMS

TROUBLE DIAGNOSIS FOR SELF-DIAGNOSTIC ITEMS

PFP:00000

Inspection 1: Transmitter or Low Tire Pressure Warning Control Unit MALFUNCTION CODE NO. 21, 22, 23 OR 24

AES000HT

1. CHECK CONTROL UNIT

- Drive for several minutes. Check all tire pressures with CONSULT-II "DATA MONITOR ITEM".

Are all tire pressures displayed 0 kPa?

- YES >> GO TO 2.
NO >> GO TO 3.

2. CHECK ANTENNA CONNECTOR

- Check antenna and feeder connector M205 for damage or loose connections.

OK or NG

- OK >> Replace control unit, then GO TO 3.
NG >> Repair or replace antenna or feeder connector.

3. ID REGISTRATION

- Perform ID registration of all transmitters.

Are there any tires that ID can not be registered to?

- YES >> Replace transmitter of the tire, then GO TO 5.
NO >> GO TO 4.

4. VEHICLE DRIVING

- Drive at a speed of 40 km/h (25 MPH) or more for several minutes without stopping.
Check all tire pressures with CONSULT-II "DATA MONITOR ITEM" within 15 minutes after vehicle speed becomes 17 km/h (11 MPH).

Does "DATA MONITOR ITEM" display tire pressure as normal without any warning lamp?

- YES >> INSPECTION END.
NO >> GO TO 5.

5. ID REGISTRATION AND VEHICLE DRIVING

1. Perform ID registration of all transmitters.
2. Drive at a speed of 40 km/h (25 MPH) or more for 3 minutes, and then drive the vehicle at any speed for 10 minutes. Then check all tire pressures with CONSULT-II "DATA MONITOR ITEM" within 5 minutes.

Does "DATA MONITOR ITEM" display tire pressure as normal without any warning lamp?

- YES >> INSPECTION END
NO >> GO TO the inspection applicable to DTC.

Inspection 2: Transmitter - 1

MALFUNCTION CODE NO. 31, 32, 33, 34, 41, 42, 43, 44, 45, 46, 47 OR 48

AES000HU

1. ID REGISTRATION (CORRECTION OF TRANSMITTER LOCATION)

1. Perform ID registration of all transmitters.
2. Drive at a speed of 40 km/h (25 MPH) or more for 3 minutes, and then drive the vehicle at any speed for 10 minutes.

>> GO TO 2.

TROUBLE DIAGNOSIS FOR SELF-DIAGNOSTIC ITEMS

2. REPLACE TRANSMITTER

1. Check warning lamp for blink again, and replace malfunctioning transmitter.
2. Perform ID registration of all transmitter.

Can ID registration of all transmitters be completed?

- YES >> GO TO 3.
NO >> GO TO the inspection 1.

3. VEHICLE DRIVING

- Drive at a speed of 40 km/h (25 MPH) or more for 3 minutes, and then drive the vehicle at any speed for 10 minutes. Then check all tire pressures with CONSULT-II "DATA MONITOR ITEM" within 5 minutes.

Does "DATA MONITOR ITEM" display tire pressure as normal without any warning lamp?

- YES >> INSPECTION END.
NO >> Replace malfunctioning transmitter, and perform "Step 3" again.

Inspection 3: Transmitter - 2 MALFUNCTION CODE NO. 35, 36, 37 OR 38

AES000NF

1. CHECK ALL TIRE PRESSURES

- Check all tire pressures.

Tire pressure : 230 kPa (2.3 kg/m² , 33 psi)

Are there any tires whose pressure is "64 psi" or more?

- YES >> Adjust tire pressure to specified value.
NO >> GO TO 2.

2. VEHICLE DRIVING

1. Perform ID registration of all transmitters.
2. Drive at a speed of 40 km/h (25 MPH) or more for several minutes without stopping. Check all tire pressures with CONSULT-II "DATA MONITOR ITEM" within 15 minutes after vehicle speed become 17 km/h (11 MPH).

>> Replace transmitter with new one if "DATA MONITOR ITEM" displays 64 psi or more. Then GO TO 3.

3. ID REGISTRATION AND VEHICLE DRIVING

- Perform ID registration of all transmitters.
- Drive at a speed of 40 km/h (25 MPH) or more for 3 minutes, and then drive the vehicle at any speed for 10 minutes. Then check all tire pressures with CONSULT-II "DATA MONITOR ITEM" within 5 minutes.

Does "DATA MONITOR ITEM" display tire pressure as normal without any warning lamp?

- YES >> INSPECTION END
NO >> GO TO the inspection applicable to DTC.

TROUBLE DIAGNOSIS FOR SELF-DIAGNOSTIC ITEMS

AES000HV

Inspection 4: Vehicle Speed Signal MALFUNCTION CODE NO. 52

1. CHECK SELF-DIAGNOSIS RESULTS CHECK

Ⓟ With CONSULT-II

1. Select "AIR PRESSURE MONITOR" on "SELECT SYSTEM" screen.
2. Select "SELF-DIAG RESULTS" on "SELECT DIAG MODE" screen.
3. Check display contents in self-diagnostic results.

Is "CAN COMM CIRCUIT" displayed in the self-diagnosis display items?

- YES >> Malfunction in CAN communication system. GO TO [LAN-5, "Precautions When Using CONSULT-II"](#).
- NO >> GO TO 2.

2. CHECK UNIFIED METER AND A/C AMP. POWER SUPPLY CIRCUIT

1. Disconnect unified meter and A/C amp. connector M50.
2. Check voltage between unified meter and A/C amp. harness connector M50 terminals 21 (Y/R), 22 (G) and ground.

Terminals		Voltage (Approx.)
(+)	(-)	
Connector	Terminal (Wire color)	Ground
M50	21 (Y/R)	
	22 (G)	12 V

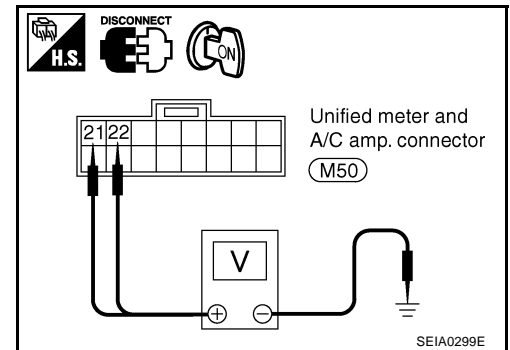

OK or NG

- OK >> GO TO 3.
- NG >> Check unified meter and A/C amp. power supply circuit for open or short.

3. CHECK UNIFIED METER AND A/C AMP. GROUND CIRCUIT

- Check continuity between unified meter and A/C amp. harness connector M50 terminals 29 (B), 30 (B) and ground.

Terminals		Continuity
(+)	(-)	
Connector	Terminal (Wire color)	Ground
M50	29 (B)	
	30 (B)	Yes

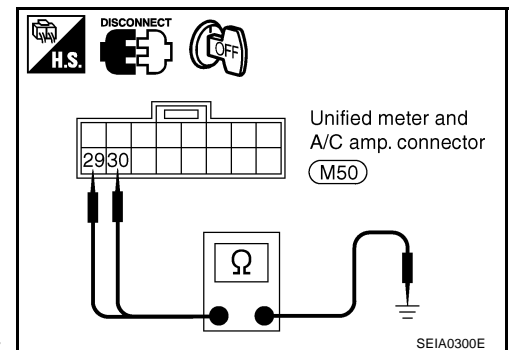

OK or NG

- OK >> Check unified meter and A/C amp self-diagnostic. Refer to [DI-32, "SELF-DIAGNOSTIC RESULTS"](#).
- NG >> Repair or replace unified meter and A/C amp. ground circuit.

TROUBLE DIAGNOSIS FOR SYMPTOMS

TROUBLE DIAGNOSIS FOR SYMPTOMS

PFP:00007

Inspection 1: Warning Lamp Does Not Come On When Ignition Switch Is Turned On.

AES000HW

DIAGNOSTIC PROCEDURE

1. SELF-DIAGNOSTIC RESULT CHECK

Ⓟ With CONSULT-II

1. Select "AIR PRESSURE MONITOR" on "SELECT SYSTEM" screen.
2. Select "SELF-DIAG RESULTS" on "SELECT DIAG MODE" screen.
3. Check display contents in self-diagnostic results.

Is "CAN COMM CIRCUIT" displayed in the self-diagnosis display items?

YES >> Malfunction in CAN communication system. GO TO [LAN-5, "Precautions When Using CONSULT-II"](#).

NO >> GO TO 2.

2. CHECK COMBINATION METER

- Check combination meter operation.

OK or NG

OK >> GO TO 3.

NG >> Check combination meter. Refer to [DI-28, "System Description"](#).

3. CHECK WARNING LAMP

- Disconnect low tire pressure warning control unit connector.

Does the warning lamp activate?

YES >> Replace low tire pressure warning control unit.

NO >> GO TO 4.

4. CHECK UNIFIED METER AND A/C AMP. POWER SUPPLY CIRCUIT

1. Disconnect unified meter and A/C amp. connector M50.
2. Check voltage between unified meter and A/C amp. harness connector M50 terminals 21 (Y/R), 22 (G) and ground.

Terminals		Voltage (Approx.)
(+)	(-)	
Connector	Terminal (Wire color)	Ground
M50	21 (Y/R)	
	22 (G)	
		12 V

OK or NG

OK >> GO TO 5.

NG >> Check unified meter and A/C amp. power supply circuit for open or short.

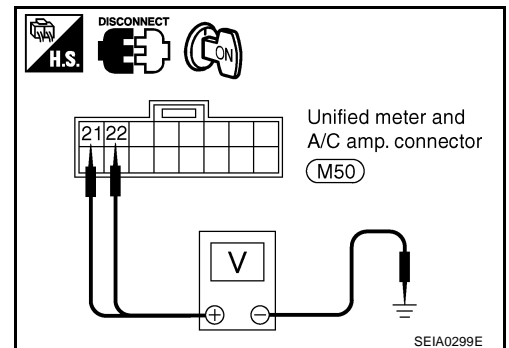

TROUBLE DIAGNOSIS FOR SYMPTOMS

5. CHECK UNIFIED METER AND A/C AMP. GROUND CIRCUIT

- Check continuity between unified meter and A/C amp. connector M50 terminals 29 (B), 30 (B) and ground.

Terminals			Continuity
(+)		(-)	
Connector	Terminal (Wire color)	Ground	Yes
M50	29 (B)	Ground	Yes
	30 (B)		

OK or NG

OK >> Check unified meter and A/C amp. Refer to [DI-28, "System Description"](#).

NG >> Repair or replace unified meter and A/C amp. ground circuit.

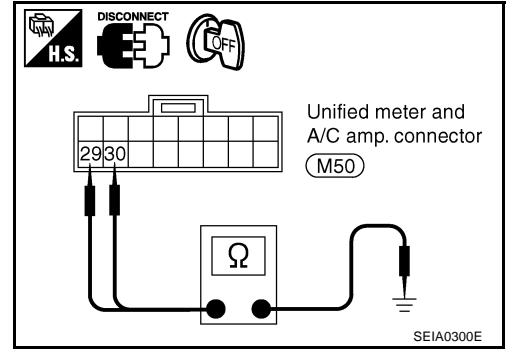

Inspection 2: Warning Lamp Stays On When Ignition Switch Is Turned On. AES000HX

DIAGNOSTIC PROCEDURE

1. CHECK CONNECTOR

- Disconnect low tire pressure warning control unit connectors M81 and M205.
- Check terminals for damage or loose connections.

OK or NG

OK >> GO TO 2.

NG >> Repair or replace damaged parts.

2. CHECK POWER SUPPLY CIRCUIT 1

Check voltage between low tire pressure warning control unit connector M81 terminal 12 (Y/R) and ground.

Terminals			Voltage (Approx.)
(+)		(-)	
Connector	Terminal (Wire color)	Ground	12 V
M81	12 (Y/R)	Ground	12 V

OK or NG

OK >> GO TO 3.

NG >> Check low tire pressure warning control unit power supply circuit for open or short.

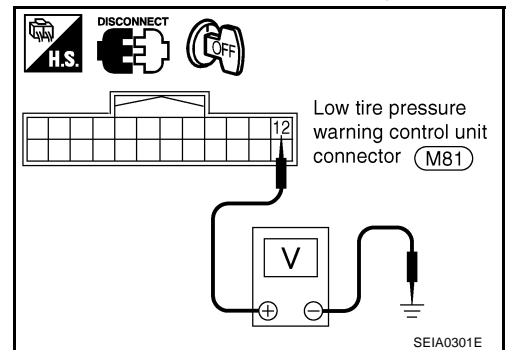

TROUBLE DIAGNOSIS FOR SYMPTOMS

3. CHECK POWER SUPPLY CIRCUIT 2

1. Turn ignition switch ON.
2. Check voltage between low tire pressure warning control unit connector M81 terminals 11 (P/B), 24 (G) and ground.

Terminals			Voltage (Approx.)
(+)		(-)	
Connector	Terminal (Wire color)	Ground	12 V
M81	11 (P/B)		
	24 (G)		

OK or NG

OK >> GO TO 4.

NG >> Check low tire pressure warning control unit power supply circuit for open or short.

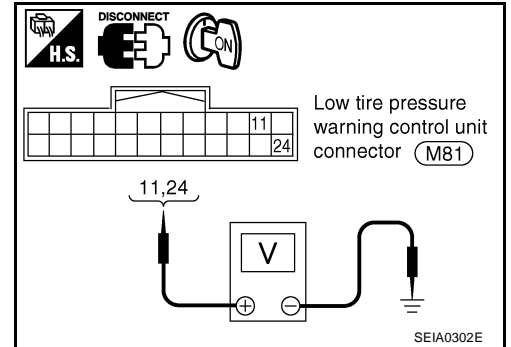

4. CHECK GROUND CIRCUIT

- Check continuity between low tire pressure warning control unit connector M81 terminal 20 (B) and ground.

Terminals			Continuity
(+)		(-)	
Connector	Terminal (Wire color)	Ground	Yes
M81	20 (B)		

OK or NG

OK >> Replace low tire pressure warning control unit.

NG >> Repair or replace low tire pressure warning control unit ground circuit.

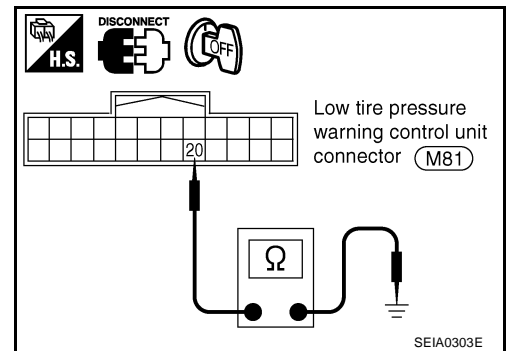

TROUBLE DIAGNOSIS FOR SYMPTOMS

Inspection 3: Warning Lamp Blinks When Ignition Switch Is Turned On.

AES000HY

NOTE:

If warning lamp blinks below, the system is normal.

Blink Mode A

- This mode shows transmitter status is in OFF-mode. Perform transmitter wake up operation. Refer to [WT-16, "Transmitter Wake Up Operation"](#).

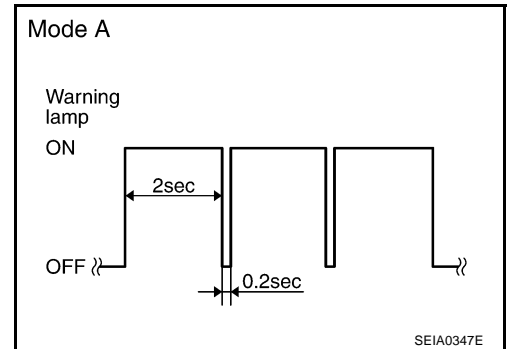

DIAGNOSTIC PROCEDURE

1. CHECK CONNECTOR

- Disconnect low tire pressure warning control unit connectors M81 and M205.
- Check terminals for damage or loose connections.

Inspection results OK?

- OK >> GO TO 2.
 NG >> Repair or replace damaged parts.

2. CHECK TIRE PRESSURE WARNING CHECK CONNECTOR CIRCUIT

- Disconnect low tire pressure warning control unit connector M81.
- Check continuity between low tire pressure warning control unit harness connector M81 terminal 8 (G/W) and ground.

Terminals		Continuity
(+)	(-)	
Connector	Terminal (Wire color)	Ground
M81	8 (G/W)	No

OK or NG

- OK >> Replace low tire pressure warning control unit.
 NG >> Repair or replace harness connector.

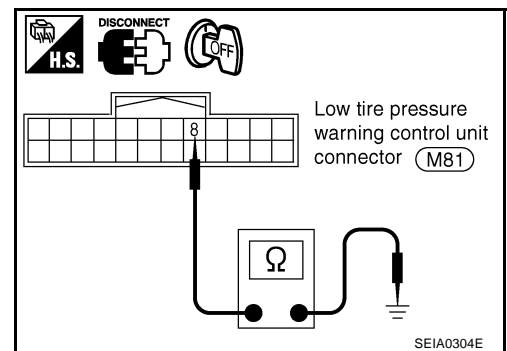

TROUBLE DIAGNOSIS FOR SYMPTOMS

Inspection 4: Hazard Warning Lamp Blinks When Ignition Switch Is Turned On.

AES000HZ

DIAGNOSTIC PROCEDURE

1. CHECK GROUND CIRCUIT

1. Disconnect low tire pressure warning control unit connector M81.
2. Check continuity between low tire pressure warning control unit harness connector M81 terminal 20 (B) and ground.

Terminals			Continuity
(+)		(-)	
Connector	Terminal (Wire color)	Ground	Yes
M81	20 (B)		

OK or NG

- OK >> Replace low tire pressure warning control unit.
 NG >> Repair or replace low tire pressure warning control unit ground circuit.

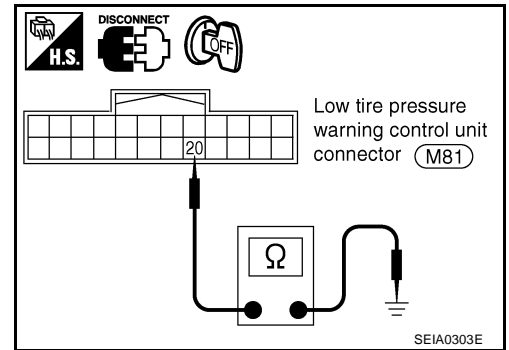

A

B

C

D

WT

F

G

H

I

J

K

L

M

TROUBLE DIAGNOSIS FOR SYMPTOMS

Inspection 5: "TIRE PRESSURE" Information In Display Unit Does Not Exist AES00010

DIAGNOSTIC PROCEDURE

1. SELF-DIAGNOSTIC RESULT CHECK

④ With CONSULT-II

1. Select "AIR PRESSURE MONITOR" on "SELECT SYSTEM" screen.
2. Select "SELF-DIAG RESULTS" on "SELECT DIAG MODE" screen.
3. Check display contents in self-diagnostic results.

Is "CAN COMM CIRCUIT" displayed in the self-diagnosis display items?

YES >> Malfunction in CAN communication system. GO TO [LAN-5, "Precautions When Using CONSULT-II"](#).

NO >> GO TO 2.

2. CHECK DISPLAY UNIT

- Perform display unit self-diagnosis. Refer to [AV-151, "Self-Diagnosis Mode \(DCU\)"](#).

OK or NG

OK >> Replace low tire pressure warning control unit.

NG >> Repair or replace malfunctioning parts.

Inspection 6: ID Registration Can not Be Completed

AES000JH

DIAGNOSTIC PROCEDURE

1. ID REGISTRATION (ALL)

- Perform ID registration of all transmitters.
- Can ID registration of all transmitters be completed?

YES or NO

YES >> INSPECTION END

NO >> Go To [WT-24, "Inspection 1: Transmitter or Low Tire Pressure Warning Control Unit"](#).

REMOVAL AND INSTALLATION

REMOVAL AND INSTALLATION

PPF:00000

Transmitter REMOVAL

AES000/3

1. Deflate tire. Unscrew transmitter retaining nut and allow transmitter to fall into tire.
2. Gently bounce tire so that transmitter falls to bottom of tire. Place on tire changing machine and break both tire beads ensuring that the transmitter remains at the bottom of the tire.

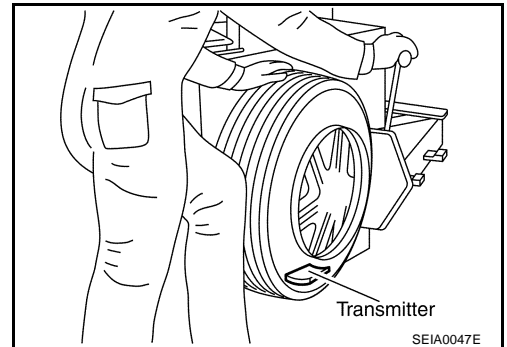

3. Turn tire so that valve hole is at bottom and bounce so that transmitter is near valve hole. Carefully lift tire onto turntable and position valve hole (and transmitter) 270 degree from mounting/dismounting head.
4. Lubricate tire well and remove first side of the tire. Reach inside the tire and remove the transmitter. Remove second side of tire.

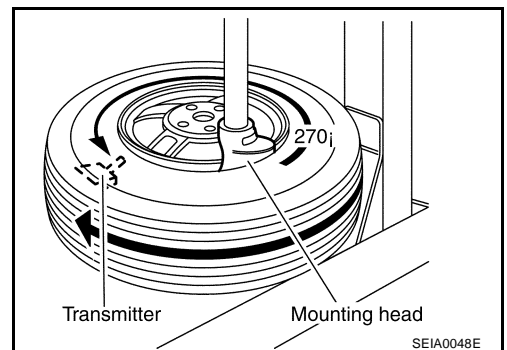

INSTALLATION

1. Put first side of tire onto rim.
2. Mount transmitter on rim and tighten nut.

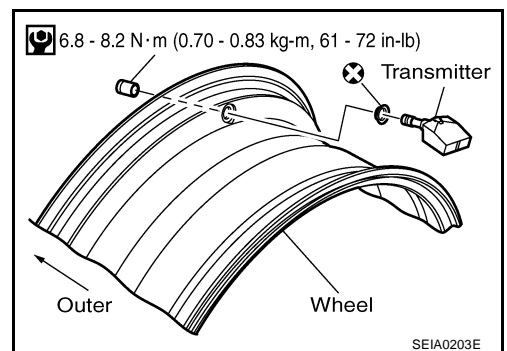
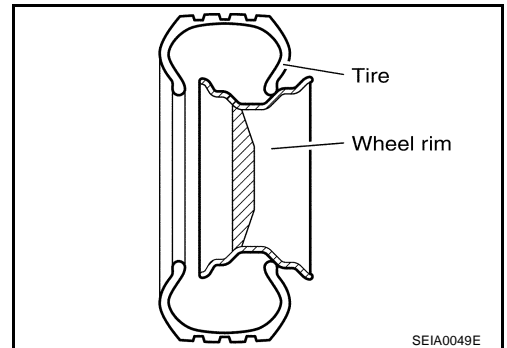

A
B
C
D
WT
F
G
H
I
J
K
L
M

REMOVAL AND INSTALLATION

- Place wheel on turntable of tire machine. Ensure that transmitter is 270 degree from mounting head when second side of tire is fitted.

NOTE:

Do not touch transmitter at mounting head.

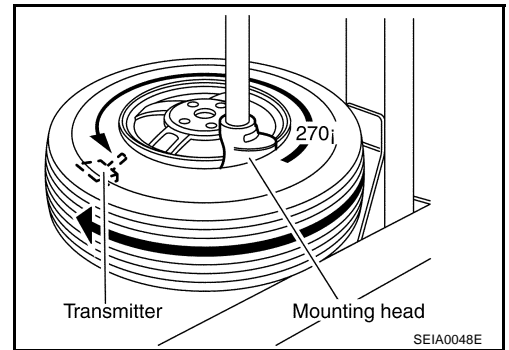

- Lubricate tire well and fit second side of tire as normal. Ensure that tire does not rotate relative to rim.
- Inflate tire and fit to appropriate wheel position.

SERVICE DATA AND SPECIFICATIONS (SDS)

SERVICE DATA AND SPECIFICATIONS (SDS)

PFP:00030

Road Wheel

AES00014

Kind of wheel		Aluminum	Steel (for emergency use)
Deflection limit	Lateral deflection	Less than 0.3 mm (0.012 in)	Less than 1.0mm (0.039 in)
	Vertical deflection	Less than 0.3mm (0.012 in)	Less than 1.2mm (0.047in)
Allowable quantity of residual unbalance	Dynamic (At rim flange)	Less than 10g (0.35oz) (per side)	
	Static (At rim flange)	Less than 20g (0.70oz)	

Tire

AES00015

Unit: kPa (kg/cm² , psi)

Tire size	Air pressure	
	Front wheel	Rear wheel
P235/65R18 104T	230 (2.3, 33)	230 (2.3, 33)
T165/90D18 107M	420 (4.2, 60)	420 (4.2, 60)

A
B
C
D
WT
F
G
H
I
J
K
L
M

SERVICE DATA AND SPECIFICATIONS (SDS)
