

SECTION **TF**
TRANSFER

A
B
C

TF

CONTENTS

E

PRECAUTIONS	3	Wiring Diagram — AWD —	18	F
Precautions for Supplemental Restraint System (SRS) "AIR BAG" and "SEAT BELT PRE-TENSIONER"	3	Trouble Diagnosis Chart for Symptoms	22	
Precautions Necessary for Steering Wheel Rotation After Battery Disconnect	3	AWD Control Unit Input/Output Signal Reference Values	23	G
OPERATION PROCEDURE	3	AWD CONTROL UNIT INSPECTION TABLE	23	
Precautions	4	CONSULT-II Function (ALL MODE AWD/4WD)	24	H
Service Notice	4	FUNCTION	24	
Wiring Diagrams and Trouble Diagnosis	5	CONSULT-II SETTING PROCEDURE	24	
PREPARATION	6	SELF-DIAG RESULT MODE	25	I
Special Service Tools	6	DATA MONITOR MODE	26	
Commercial Service Tools	8	ACTIVE TEST MODE	27	J
NOISE, VIBRATION AND HARSHNESS (NVH)		AWD CONTROL UNIT PART NUMBER	27	
TROUBLESHOOTING	9	TROUBLE DIAGNOSIS FOR SYSTEM	28	K
NVH Troubleshooting Chart	9	Power Supply Circuit For AWD Control Unit	28	
TRANSFER OIL	10	CONSULT-II REFERENCE VALUE IN DATA MONITOR MODE	28	L
Replacement	10	DIAGNOSTIC PROCEDURE	28	
DRAINING	10	AWD Control Unit	29	M
FILLING	10	DIAGNOSTIC PROCEDURE	29	
Inspection	10	ABS System	29	
OIL LEAKAGE AND OIL LEVEL	10	DIAGNOSTIC PROCEDURE	29	
AWD SYSTEM	11	AWD Solenoid	30	
Power Transfer Diagram	11	CONSULT-II REFERENCE VALUE IN DATA MONITOR MODE	30	
System Description	11	DIAGNOSTIC PROCEDURE	31	
ELECTRIC CONTROLLED COUPLING	11	COMPONENT INSPECTION	32	
AWD CONTROL UNIT	11	AWD Actuator Relay	33	
AWD LOCK SWITCH	12	CONSULT-II REFERENCE VALUE IN DATA MONITOR MODE	33	
AWD LOCK INDICATOR LAMP	12	DIAGNOSTIC PROCEDURE	33	
AWD WARNING LAMP	12	COMPONENT INSPECTION	36	
System Diagram	13	AWD Lock Switch	34	
COMPONENTS FUNCTION DESCRIPTION	14	CONSULT-II REFERENCE VALUE IN DATA MONITOR MODE	34	
CAN Communication	14	DIAGNOSTIC PROCEDURE	34	
SYSTEM DESCRIPTION	14	COMPONENT INSPECTION	36	
TROUBLE DIAGNOSIS	15	Engine Control Signal	36	
Fail-Safe Function	15	DIAGNOSTIC PROCEDURE	36	
How to Perform Trouble Diagnosis	15	CAN Communication Line	36	
BASIC CONCEPT	15	DIAGNOSTIC PROCEDURE	36	
Location of Electrical Parts	16	TROUBLE DIAGNOSIS FOR SYMPTOMS	38	
Circuit Diagram	17			

AWD LOCK Indicator Lamp Does Not Turn ON for Approx. 1 Second When The Ignition Switch Is Turned to ON	38	SIDE OIL SEAL	50
DIAGNOSTIC PROCEDURE	38	Removal and Installation	50
AWD Warning Lamp Does Not Turn ON When The Ignition Switch Is Turned to ON	40	REMOVAL	50
DIAGNOSTIC PROCEDURE	40	INSTALLATION	50
AWD Warning Lamp Does Not Turn OFF Several Seconds after Engine Started	41	AIR BREATHER HOSE	51
DIAGNOSTIC PROCEDURE	41	Components	51
AWD Mode Cannot Be Switched after Engine Is Started	43	Removal and Installation	51
DIAGNOSTIC PROCEDURE	43	TRANSFER ASSEMBLY	52
Heavy Tight-corner Braking Symptom Occurs When The Vehicle Is Driven in AUTO Mode and The Steering Wheel Is Turned Fully to Either Side after The Engine Is Started	45	Removal and Installation	52
DIAGNOSTIC PROCEDURE	45	COMPONENTS	52
Vehicle Does Not Enter AWD Mode Even Though AWD Warning Lamp Turned to OFF	46	REMOVAL	52
DIAGNOSTIC PROCEDURE	46	INSTALLATION	52
While Driving, AWD Warning Lamp Flashes Rapidly (When Flashing in Approx. 1 Minute and Then Turn- ing OFF)	47	Disassembly and Assembly	54
While Driving, AWD Warning Lamp Flashes Slowly (When Continuing to Flash until Turning Ignition Switch OFF)	47	COMPONENTS	54
DIAGNOSTIC PROCEDURE	47	ASSEMBLY INSPECTION	55
AWD CONTROL UNIT	49	DISASSEMBLY	59
Removal and Installation	49	INSPECTION AFTER DISASSEMBLY	63
REMOVAL	49	SELECTING ADJUSTING SHIMS	64
INSTALLATION	49	ASSEMBLY	65
		SERVICE DATA AND SPECIFICATIONS (SDS)	71
		General Specifications	71
		Inspection and Adjustment	71
		PRELOAD TORQUE BEFORE DISASSEMBLY...	71
		PRELOAD TORQUE AFTER DISASSEMBLY AND REASSEMBLY	71
		BACKLASH	71
		COMPANION FLANGE RUNOUT	71
		SELECTIVE PARTS	71

PRECAUTIONS

PRECAUTIONS

PFP:00001

Precautions for Supplemental Restraint System (SRS) “AIR BAG” and “SEAT BELT PRE-TENSIONER”

ADS001B5

The Supplemental Restraint System such as “AIR BAG” and “SEAT BELT PRE-TENSIONER”, used along with a front seat belt, helps to reduce the risk or severity of injury to the driver and front passenger for certain types of collision. This system includes seat belt switch inputs and dual stage front air bag modules. The SRS system uses the seat belt switches to determine the front air bag deployment, and may only deploy one front air bag, depending on the severity of a collision and whether the front occupants are belted or unbelted. Information necessary to service the system safely is included in the SRS and SB section of this Service Manual.

WARNING:

- To avoid rendering the SRS inoperative, which could increase the risk of personal injury or death in the event of a collision which would result in air bag inflation, all maintenance must be performed by an authorized NISSAN/INFINITI dealer.
- Improper maintenance, including incorrect removal and installation of the SRS, can lead to personal injury caused by unintentional activation of the system. For removal of Spiral Cable and Air Bag Module, see the SRS section.
- Do not use electrical test equipment on any circuit related to the SRS unless instructed to in this Service Manual. SRS wiring harnesses can be identified by yellow and/or orange harnesses or harness connectors.

Precautions Necessary for Steering Wheel Rotation After Battery Disconnect

ADS001AW

NOTE:

- This Procedure is applied only to models with Intelligent Key system and NVIS/IVIS (NISSAN/INFINITI VEHICLE IMMOBILIZER SYSTEM - NATS).
- Remove and install all control units after disconnecting both battery cables with the ignition knob in the “LOCK” position.
- Always use CONSULT-II to perform self-diagnosis as a part of each function inspection after finishing work. If DTC is detected, perform trouble diagnosis according to self-diagnostic results.

For models equipped with the Intelligent Key system and NVIS/IVIS, an electrically controlled steering lock mechanism is adopted on the key cylinder.

For this reason, if the battery is disconnected or if the battery is discharged, the steering wheel will lock and steering wheel rotation will become impossible.

If steering wheel rotation is required when battery power is interrupted, follow the procedure below before starting the repair operation.

OPERATION PROCEDURE

1. Connect both battery cables.

NOTE:

Supply power using jumper cables if battery is discharged.

2. Use the Intelligent Key or mechanical key to turn the ignition switch to the “ACC” position. At this time, the steering lock will be released.
3. Disconnect both battery cables. The steering lock will remain released and the steering wheel can be rotated.
4. Perform the necessary repair operation.
5. When the repair work is completed, return the ignition switch to the “LOCK” position before connecting the battery cables. (At this time, the steering lock mechanism will engage.)
6. Perform a self-diagnosis check of all control units using CONSULT-II.

PRECAUTIONS

ADS000WC

Precautions

- Before connecting or disconnecting the AWD control unit harness connector, turn ignition switch "OFF" and disconnect battery ground cable. Because battery voltage is applied to AWD control unit even if ignition switch is turned "OFF".

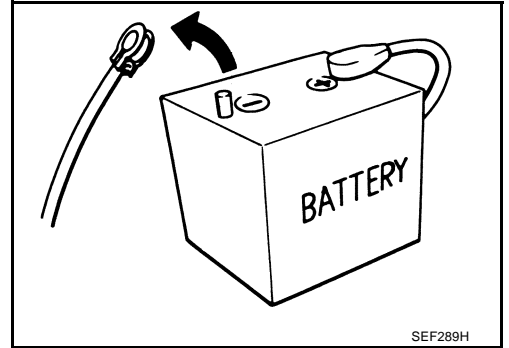

- When connecting or disconnecting pin connectors into or from AWD control unit, take care not to damage pin terminals (bend or break). When connecting pin connectors, make sure that there are no bends or breaks on AWD control unit pin terminal.

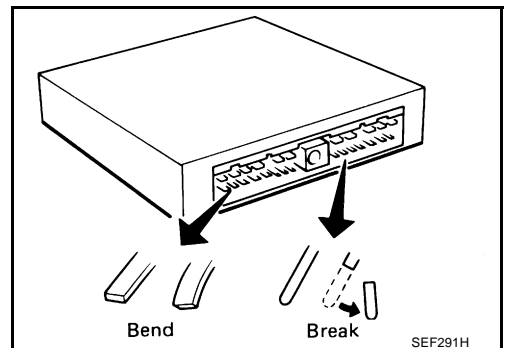

- Before replacing AWD control unit, perform AWD control unit input/output signal inspection and make sure whether AWD control unit functions properly or not. Refer to [TF-23, "AWD Control Unit Input/Output Signal Reference Values"](#).

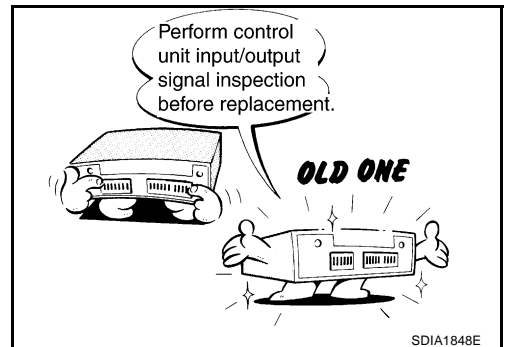

Service Notice

ADS000WD

- After overhaul refill the transfer with new transfer oil.
- Check the oil level or replace the oil only with the vehicle parked on level surface.
- During removal or installation, keep inside of transfer clear of dust or dirt.
- Replace all tires at the same time. Always use tires of the proper size and the same brand and pattern. Fitting improper size and unusual wear tires applies excessive force to vehicle mechanism and can cause longitudinal vibration.
- Disassembly should be done in a clean work area.
- Before proceeding with disassembly, thoroughly clean the transfer. It is important to prevent the internal parts from becoming contaminated by dirt or other foreign matter.
- Check for the correct installation status prior to removal or disassembly. If matching marks are required, be certain they do not interfere with the function of the parts when applied.
- All parts should be carefully cleaned with a general purpose, non-flammable solvent before inspection or reassembly.
- Check appearance of the disassembled parts for damage, deformation, and unusual wear. Replace them with a new ones if necessary.
- Gaskets, seals, O-rings and lock nuts should be replaced any time when the transfer is disassembled.
- In principle, tighten bolts or nuts gradually in several steps working diagonally from inside to outside. If tightening sequence is specified, use it.

PRECAUTIONS

- Observe the specified torque when assembling.
- Clean and flush the parts sufficiently and blow-dry them.
- Be careful not to damage sliding surfaces and mating surfaces.
- Use lint-free cloth or towels for wiping parts clean. Common shop rags can leave fibers that could interfere with the operation of the transfer.

A
B

Wiring Diagrams and Trouble Diagnosis

ADS000WE

When reading wiring diagrams, refer to the following:

- [GI-15, "How to Read Wiring Diagrams"](#).
- [PG-3, "POWER SUPPLY ROUTING CIRCUIT"](#).

C

When performing trouble diagnosis, refer to the following:

- [GI-11, "How to Follow Trouble Diagnoses"](#).
- [GI-27, "How to Perform Efficient Diagnosis for an Electrical Incident"](#).

TF

E

F

G

H

I

J

K

L

M

PREPARATION

PREPARATION

PFP:00002

Special Service Tools

ADS000UB

The actual shapes of Kent-Moore tools may differ from those of special service tools illustrated here.

Tool number (Kent-Moore No.) Tool name	Description
KV38101700 (—) Drift a: 82 mm (3.23 in) dia. b: 78 mm (3.07 in) dia.	Installing side oil seal (installing adapter case oil seal)
ST3127S000 (J-25765-A) Preload gauge	Measuring preload torque
ST33220000 (J-25804-01) Drift a: 37 mm (1.46 in) dia. b: 31 mm (1.22 in) dia. c: 22 mm (0.87 in) dia.	Removing drive pinion
KV381054S0 (J-34286) Puller	<ul style="list-style-type: none"> ● Removing pinion rear bearing outer race ● Removing pinion front bearing outer race ● Removing gear ring oil seal
ST30031000 (J-22912-01) Replacer	Removing pinion front bearing inner race
ST33200000 (J-26082) Drift a: 60 mm (2.36 in) dia. b: 44.5 mm (1.752 in) dia.	<ul style="list-style-type: none"> ● Removing gear ring bearing inner race (adapter case side) ● Installing companion flange
ST33061000 (J-8107-2) Drift a: 38 mm (1.50 in) dia. b: 28.5 mm (1.122 in) dia.	Removing gear ring bearing inner race (transfer case side)

PREPARATION

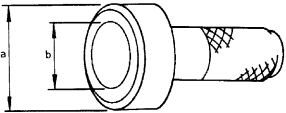
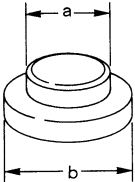
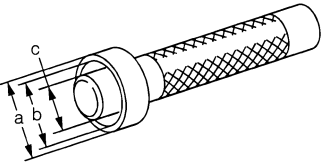
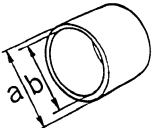
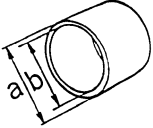
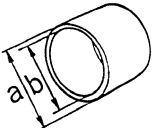
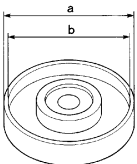
Tool number (Kent-Moore No.) Tool name	Description
ST30720000 (J-25405) Drift a: 77 mm (3.03 in) dia. b: 55.5 mm (2.185 in) dia.	 <ul style="list-style-type: none"> ● Installing gear ring bearing outer race (transfer case side) ● Installing gear ring bearing inner race (transfer case side) ● Installing gear ring bearing inner race (adapter case side) ● Installing gear ring bearing outer race (adapter case side) ● Installing transfer case oil seal
KV40101840 (—) Drift a: 77 mm (3.03 in) dia. b: 85 mm (3.35 in) dia.	 Installing gear ring bearing outer race (transfer case side)
ST33230000 (J-25805-01) Drift a: 51 mm (2.01 in) dia. b: 41 mm (1.61 in) dia. c: 28.5 mm (1.122 in) dia.	 Installing gear ring oil seal
ST27863000 (—) Drift a: 74.5 mm (2.933 in) dia. b: 62.5 mm (2.461 in) dia.	 Installing gear ring bearing inner race (transfer case side)
KV40101630 (J-35870) Drift a: 68 mm (2.68 in) dia. b: 60 mm (2.36 in) dia.	 Installing gear ring bearing inner race (transfer case side)
KV38102510 (—) Drift a: 71 mm (2.80 in) dia. b: 65 mm (2.56 in) dia.	 Installing gear ring bearing inner race (adapter case side)
KV40105230 (—) Drift a: 92 mm (3.62 in) dia. b: 86 mm (3.39 in) dia.	 Installing gear ring bearing outer race (adapter case side)

A
 B
 C
TF
 E
 F
 G
 H
 I
 J
 K
 L
 M

PREPARATION

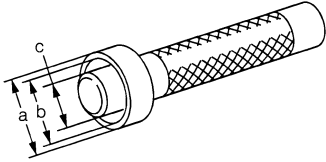
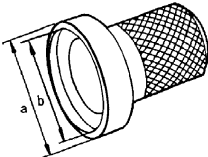
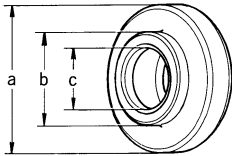
Tool number (Kent-Moore No.) Tool name	Description	
KV38100300 (J-25523) Drift a: 54 mm (2.13 in) dia. b: 46 mm (1.81 in) dia. c: 32 mm (1.26 in) dia.	 <p style="text-align: right;">ZZA1046D</p>	Installing pinion rear bearing outer race
ST33400001 (J-26082) Drift a: 60 mm (2.36 in) dia. b: 47 mm (1.85 in) dia.	 <p style="text-align: right;">ZZA0814D</p>	<ul style="list-style-type: none"> ● Installing pinion front bearing outer race ● Installing pinion sleeve oil seal
ST30901000 (J-26010-01) Drift a: 79 mm (3.11 in) dia. b: 45 mm (1.77 in) dia. c: 35.2 mm (1.386 in) dia.	 <p style="text-align: right;">ZZA0978D</p>	<ul style="list-style-type: none"> ● Installing pinion front bearing outer race ● Installing pinion front bearing inner race

Commercial Service Tools

ADS000WY

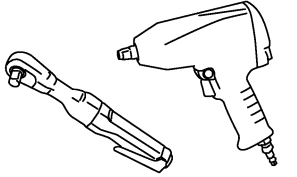
Tool name	Description
Power tool	 <p style="text-align: right;">PBIC0190E</p> <ul style="list-style-type: none"> ● Loosening nuts and bolts

NOISE, VIBRATION AND HARSHNESS (NVH) TROUBLESHOOTING

NOISE, VIBRATION AND HARSHNESS (NVH) TROUBLESHOOTING

PFP:00003

NVH Troubleshooting Chart

ADS000WF

Use the chart below to help you find the cause of the symptom. The numbers indicate the order of the inspection. If necessary, repair or replace these parts.

Reference page		TF-10			TF-54	TF-54	TF-54	TF-63	TF-63
SUSPECTED PARTS (Possible cause)		TRANSFER OIL (Level low)	TRANSFER OIL (Wrong)	TRANSFER OIL (Level too high)	LIQUID GASKET (Damaged)	O-RING (Worn or damaged)	OIL SEAL (Worn or damaged)	GEAR (Worn or damaged)	BEARING (Worn or damaged)
Symptom	Noise	1	2					3	3
	Transfer oil leakage		3	1	2	2	2		

A
B
C
TF
E
F
G
H
I
J
K
L
M

TRANSFER OIL

Replacement DRAINING

CAUTION:

When draining oil, protect exhaust tube flange with cover.

1. Run the vehicle to warm up the transfer body sufficiently.
2. Stop the engine, and remove the drain plug to drain the transfer oil.
3. Apply sealant to drain plug. Install drain plug on transfer and tighten to the specified torque. Refer to [TF-54, "COMPONENTS"](#).
 - Use Genuine Silicone RTV or equivalent. Refer to [GI-47, "Recommended Chemical Products and Sealants"](#).

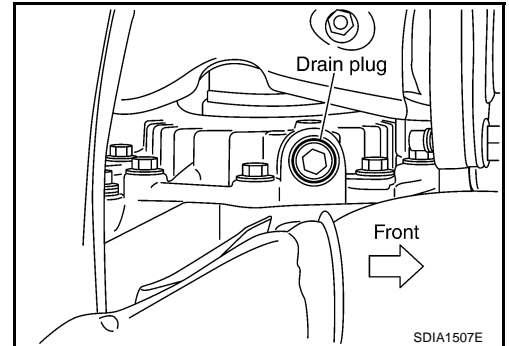

FILLING

1. Remove filler plug and add gear oil until oil level reaches the specified limit near filler plug mounting hole.
 - Oil capacity : Approx. 0.31 l (5/8 US pt, 1/2 Imp pt)

CAUTION:

Carefully fill the oil. (Fill up for approx. 3 minutes)

2. Leave the vehicle for 3 minutes, and check the oil level again.
3. Apply sealant to filler plug. Install filler plug to transfer and tighten to the specified torque. Refer to [TF-54, "COMPONENTS"](#).
 - Use Genuine Silicone RTV or equivalent. Refer to [GI-47, "Recommended Chemical Products and Sealants"](#).

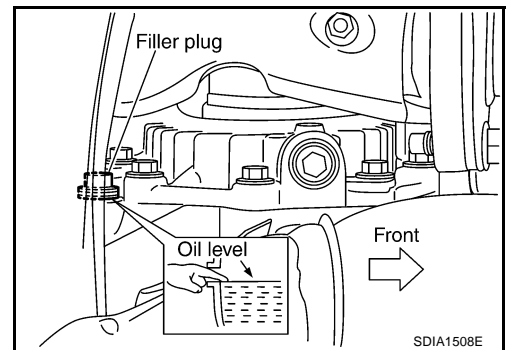

Inspection

OIL LEAKAGE AND OIL LEVEL

1. Check oil level from filler plug mounting hole as shown in the figure.

CAUTION:

Do not start engine while checking oil level.

2. Before installing filler plug, apply sealant. Install filler plug on transfer and tighten to the specified torque. Refer to [TF-54, "COMPONENTS"](#).
 - Use Genuine Silicone RTV or equivalent. Refer to [GI-47, "Recommended Chemical Products and Sealants"](#).

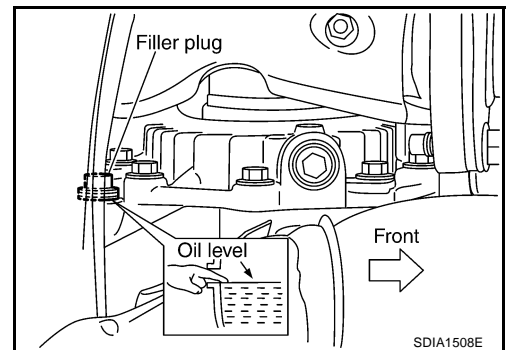

AWD SYSTEM

AWD SYSTEM

PPF:41650

Power Transfer Diagram

ADS000WG

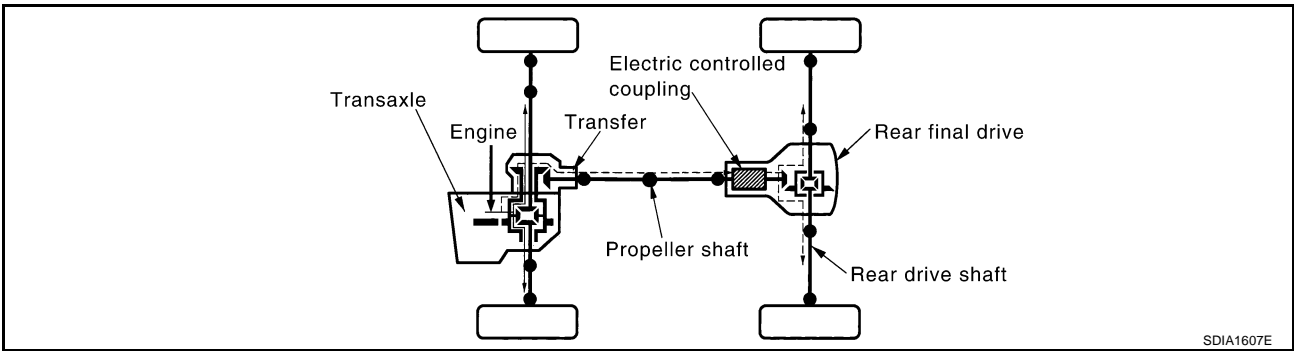

SDIA1607E

System Description ELECTRIC CONTROLLED COUPLING

ADS000WH

Operation Principle

1. AWD control unit supplies command current to electric controlled coupling (AWD solenoid).
2. Control clutch is engaged by electromagnet and torque is detected in control clutch.
3. The cam operates in response to control clutch torque and applies pressure to main clutch.
4. Main clutch transmits torque to front wheels according to pressing power.

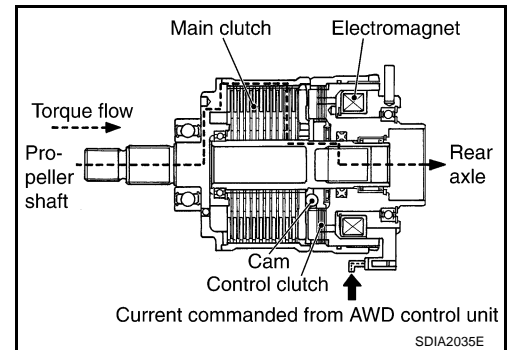

- Transmission torque to rear wheels is determined according to command current.

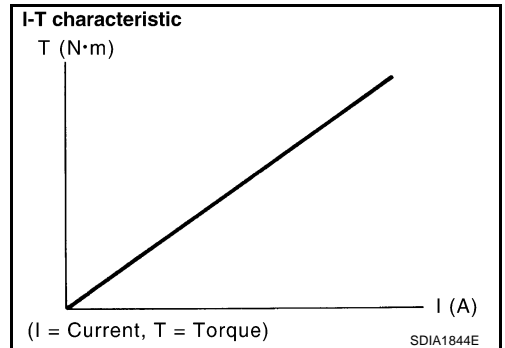

AWD CONTROL UNIT

- AWD control unit controls distribution of drive power between front-wheel drive (100:0) and AWD (50:50) conditions according to signals from the sensors.
- Self-diagnosis results can be read with CONSULT-II.

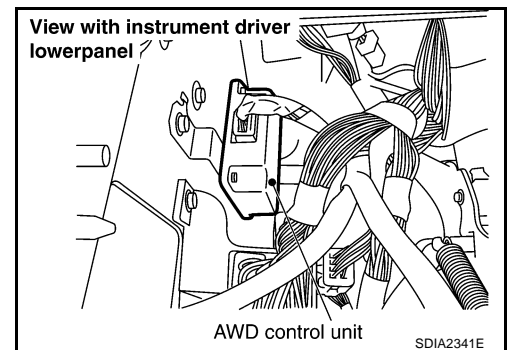

AWD SYSTEM

AWD LOCK SWITCH

AUTO Mode

- Electronic control allows optimal distribution of torque to front/rear wheels to match road conditions.
- AUTO mode makes stable driving possible, with no wheel spin, on snowy roads or other slippery surfaces.
- On roads which do not require AWD, it contributes to improved fuel economy by driving in conditions close to front-wheel drive.
- Sensor inputs determine the vehicle's turning condition, and tight cornering/braking are controlled by distributing optimum torque to the rear wheels.

LOCK Mode

- Front/rear wheel torque distribution is fixed, ensuring stable driving when climbing slopes.
- Vehicle will switch automatically to AUTO mode if vehicle speed increases. If vehicle speed then decreases, the vehicle automatically returns to direct 4-wheel driving conditions. The AWD LOCK indicator lamp keeps illuminating.
- LOCK mode will change to AUTO mode automatically, when the vehicle speed exceeds approx. 10 km/h (6 MPH) for a long time. The AWD LOCK indicator lamp turns off.
- When the vehicle speed exceeds approx. 10 km/h (6 MPH), AUTO mode cannot be shifted to LOCK mode. In contrast, LOCK mode can be shifted to AUTO mode.
- LOCK mode will change to AUTO mode automatically, when the ignition switch is turned "OFF".

NOTE:

- Every time AWD LOCK switch is pressed, AUTO mode and LOCK mode switch each other.
- When driving in AUTO mode or LOCK mode, if there is a large difference between front and rear wheel speed which continues for a long time, oil temperature of drive system parts becomes too high and AWD warning lamp flashes rapidly. (When AWD warning lamp flashes, vehicle changes to front-wheel drive conditions.)
- If AWD warning lamp is flashing rapidly, stop vehicle and allow it to idle for some time. Flashing will stop and AUTO mode will be restored.
- When driving in AUTO mode, AWD warning lamp may flash slowly if there is a significant difference in diameter of the tires. At this time, vehicle performance is not fully available and cautious driving is required. (Continues until engine is turned OFF.)
- If the warning lamp flashes slowly during driving but remains OFF after engine is restarted, the system is normal. If it again flashes slowly after driving for some time, vehicle must be inspected.
- If there is a difference of revolution speed between the front and rear wheel with AUTO mode the shift occasionally changes to LOCK mode automatically. This is not malfunction.
- If there is a significant difference in pressure or wear between tires, full vehicle performance is not available. Tire conditions are detected, and LOCK mode may be prohibited, or else speeds at which LOCK mode is enabled may be restricted.

AWD LOCK INDICATOR LAMP

The following is the indications of indicator lamp.

Condition	AWD LOCK indicator lamp
AUTO mode	OFF
LOCK mode	ON
Lamp check	Turns ON for approx. 1 second when ignition switch is turned ON.

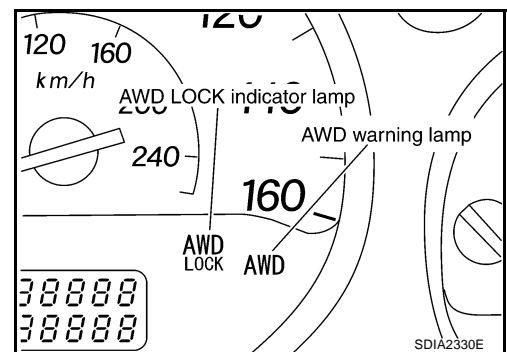

AWD WARNING LAMP

Turns ON when there is a malfunction in AWD system. It indicates that fail-safe mode is engaged and vehicle change to front-wheel drive or shifting driving force-AWD (Rear-wheels still have some driving torque). Also turns ON when ignition switch is turned ON, for purpose of lamp check. Turns OFF approximately in 1 seconds after the engine starts if system is normal.

AWD SYSTEM

AWD Warning Lamp Indication

Condition	AWD warning lamp
Lamp check	Turns ON when ignition switch is turned ON. Turns OFF approx. 1 seconds after engine start.
AWD system malfunction	ON
Protection function is activated due to heavy load to electric controlled coupling. (AWD system is not malfunctioning and AWD system changes to 2WD mode.)	Rapid flashing: 2 times/second (Flashing in approx. 1 minute and then turning OFF.)
Large difference in diameter of front/rear tires	Slow flashing: 1 time/2 seconds (Continuing to flash until turning ignition switch OFF)
Other than above (system normal)	OFF

System Diagram

ADS000V9

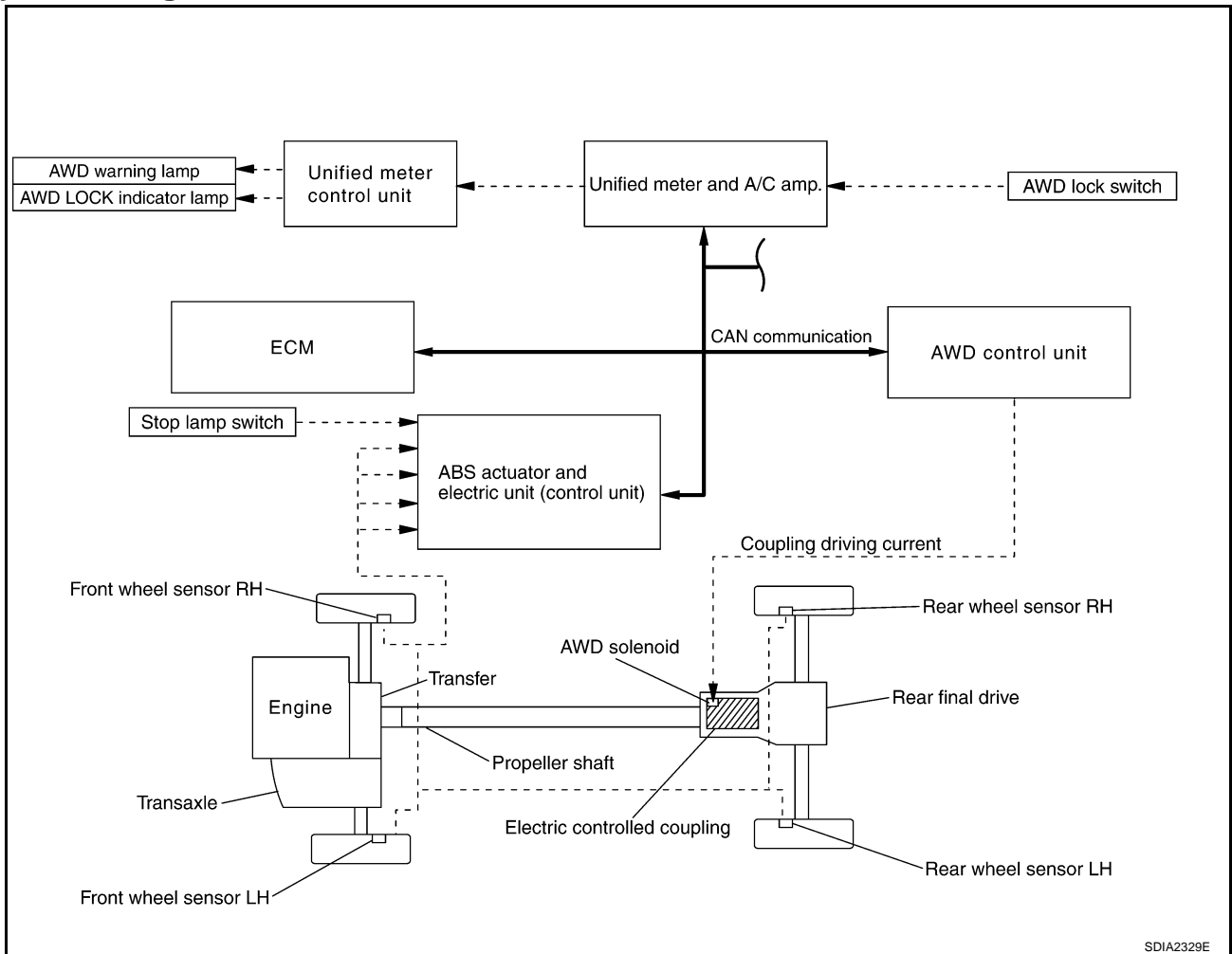

AWD SYSTEM

COMPONENTS FUNCTION DESCRIPTION

Component parts	Function
AWD control unit	<ul style="list-style-type: none"> ● Controls driving force distribution by signals from each sensor and switch from front wheel driving mode (100:0) to AWD mode (50:50). ● 2WD mode is available by fail-safe function if malfunction is detected in AWD system.
Wheel sensors	Detects wheel speed.
AWD solenoid	Controls electric controlled coupling by command current from AWD control unit.
Electric controlled coupling	Transmits driving force to rear final drive.
AWD lock switch	Able to select AUTO or LOCK mode.
AWD warning lamp	<ul style="list-style-type: none"> ● Illuminates if malfunction is detected in electrical system of AWD system. ● There is 1 blink in 2 seconds if rotation difference of front wheels and rear wheels is large. ● There are 2 blinks in 1 second if load is still applied to driving parts.
AWD LOCK indicator lamp	Illuminates in LOCK mode (direct AWD mode) and does not illuminate in AUTO mode.
ABS actuator and electric unit (control unit)	Transmits the following signals via CAN communication to AWD control unit. <ul style="list-style-type: none"> ● Vehicle speed signal ● Stop lamp switch signal (brake signal)
ECM	Transmits the following signals via CAN communication to AWD control unit. <ul style="list-style-type: none"> ● Accelerator pedal position signal ● Engine speed signal
Unified meter and A/C amp.	Transmits conditions of AWD lock switch and parking brake switch via CAN communication to AWD control unit.

CAN Communication SYSTEM DESCRIPTION

ADS000VA

CAN (Controller Area Network) is a serial communication line for real time application. It is an on-vehicle multiplex communication line with high data communication speed and excellent error detection ability. Many electronic control units are equipped onto a vehicle, and each control unit shares information and links with other control units during operation (not independent). In CAN communication, control units are connected with 2 communication lines (CAN H line, CAN L line) allowing a high rate of information transmission with less wiring. Each control unit transmits/receives data but selectively reads required data only.

For details, refer to [LAN-29, "CAN Communication Unit"](#).

TROUBLE DIAGNOSIS

PFP:00004

Fail-Safe Function

ADS000WJ

- If any malfunction occurs in AWD electrical system, and control unit detects the malfunction, AWD warning lamp on combination meter turns ON to indicate system malfunction.
- When AWD warning lamp is ON, vehicle changes to front-wheel drive or shifting driving force-AWD (Rear-wheels still have some driving torque).

How to Perform Trouble Diagnosis BASIC CONCEPT

ADS000WJ

- To perform trouble diagnosis, it is the most important to have understanding about vehicle systems (control and mechanism) thoroughly.
- It is also important to clarify customer complaints before inspection.

First of all, reproduce symptoms, and understand them fully. Ask customer about his/her complaints carefully. In some cases, it will be necessary to check symptoms by driving vehicle with customer.

CAUTION:

Customers are not professional. It is dangerous to make an easy guess like "maybe the customer means that...," or "maybe the customer mentions this symptom".

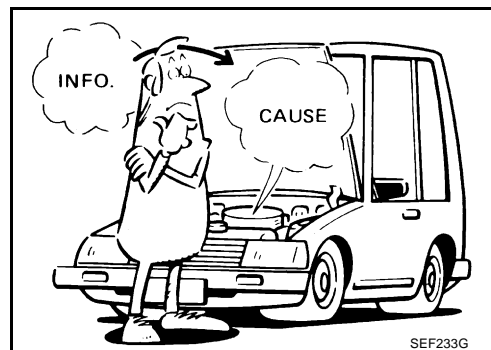

- It is essential to check symptoms right from the beginning in order to repair malfunctions completely. For intermittent malfunctions, reproduce symptoms based on interview with customer and past examples. Do not perform inspection on ad hoc basis. Most intermittent malfunctions are caused by poor contacts. In this case, it will be effective to shake suspected harness or connector by hand. When repairing without any symptom diagnosis, you cannot judge if malfunctions have actually been eliminated.
- After completing diagnosis, always erase diagnostic memory. Refer to [TF-25, "How to Erase Self-diagnostic Results"](#).
- For intermittent malfunctions, move harness or harness connector by hand. Then check for poor contact or reproduced open circuit.

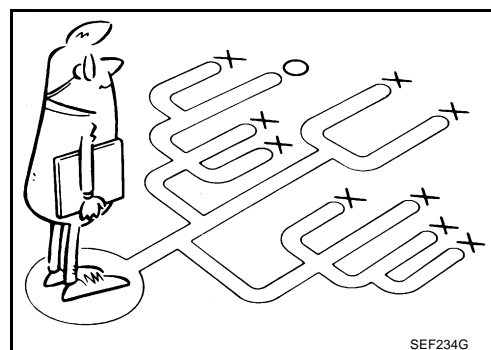

A
B
C
TF
E
F
G
H
I
J
K
L
M

TROUBLE DIAGNOSIS

Location of Electrical Parts

ADS000WL

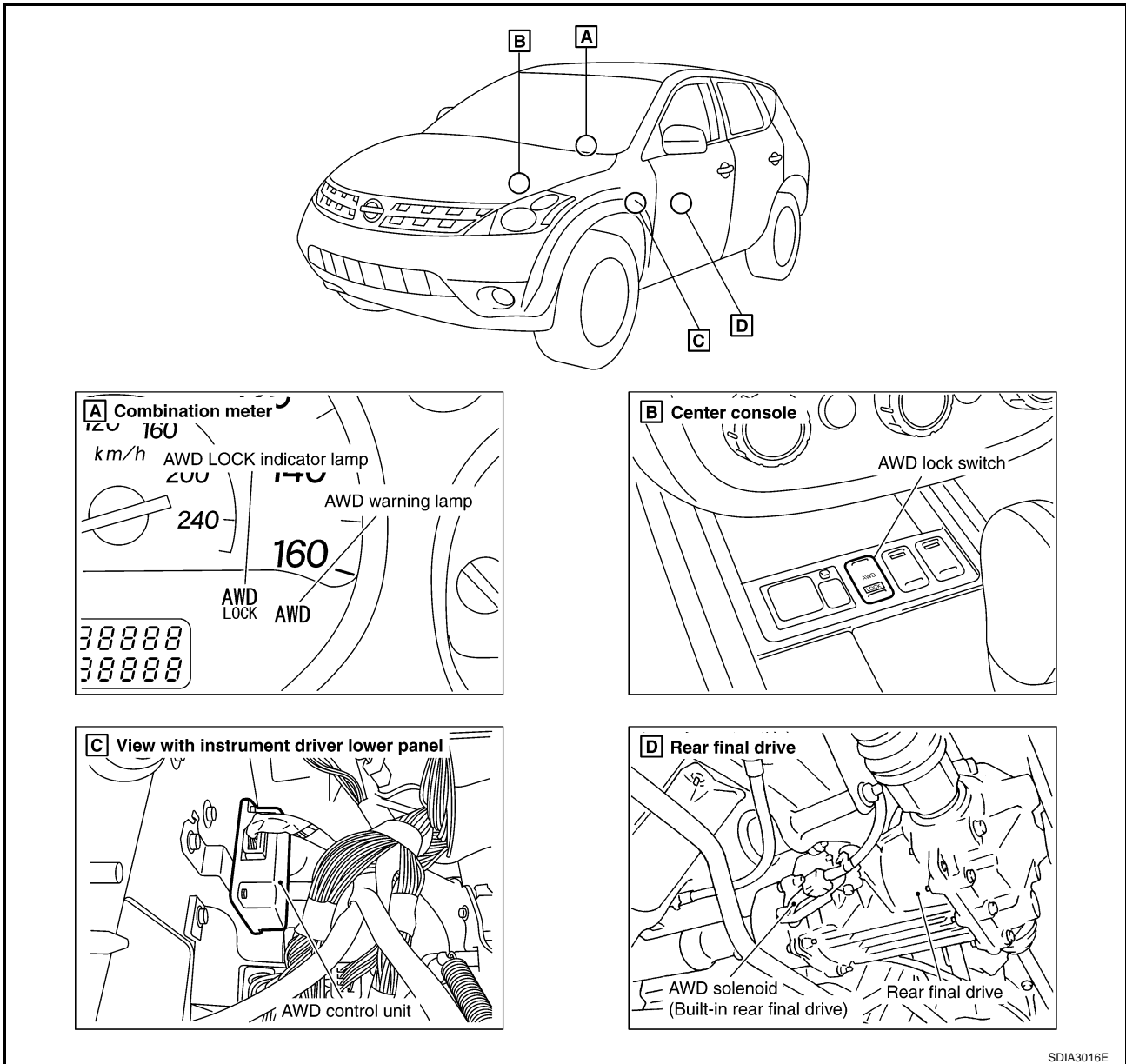

TROUBLE DIAGNOSIS

Circuit Diagram

ADS000VE

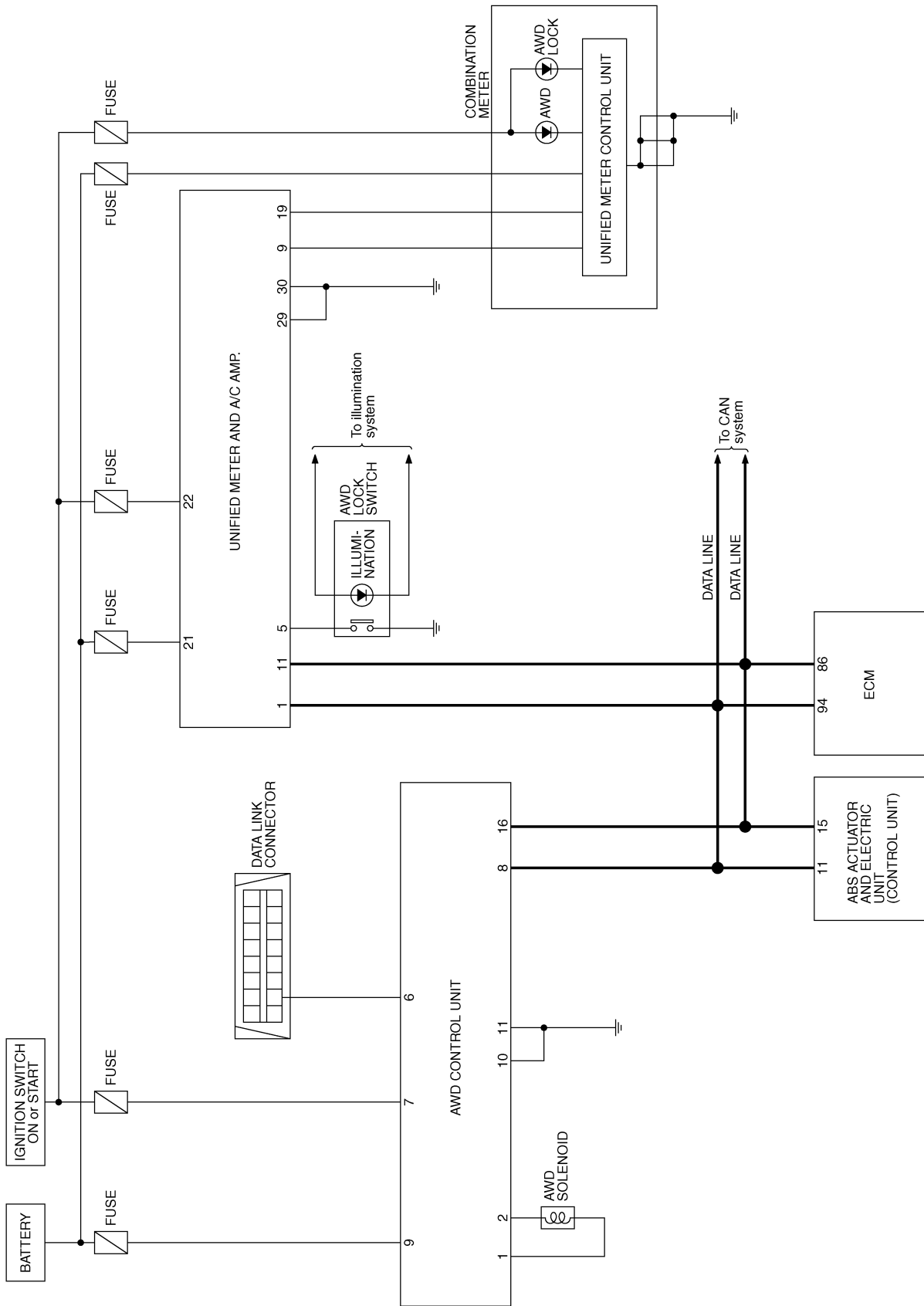

TDWB0013E

A
B
C
TF
E
F
G
H
I
J
K
L
M

TROUBLE DIAGNOSIS

Wiring Diagram — AWD —

ADS000VF

TF-AWD-01

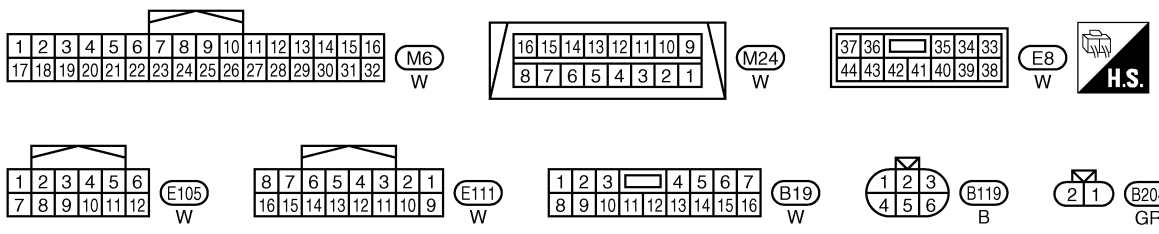
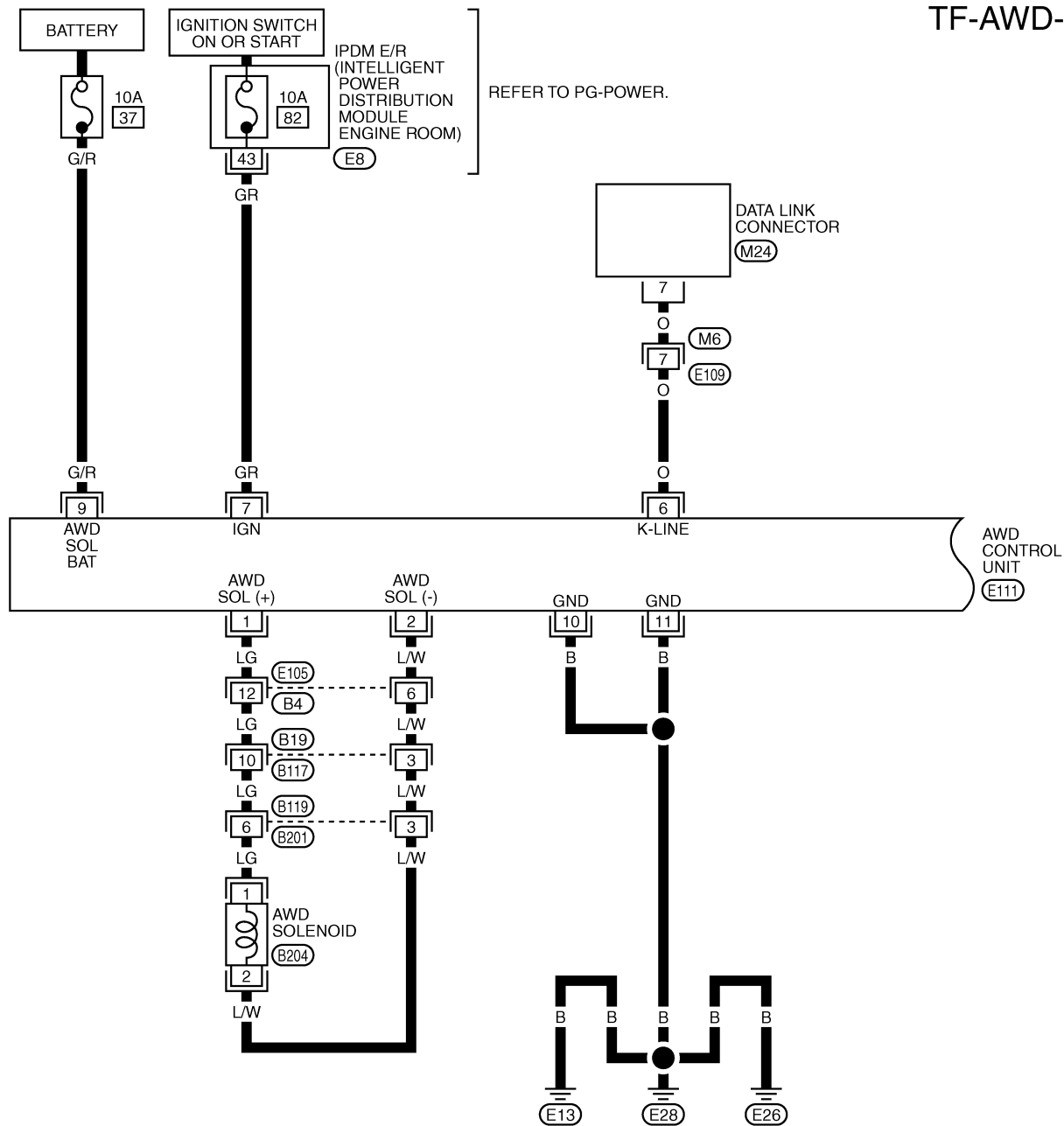

TDWB0014E

TROUBLE DIAGNOSIS

TF-AWD-02

A
B
C
TF
E
F
G
H
I
J
K
L
M

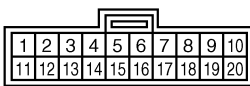
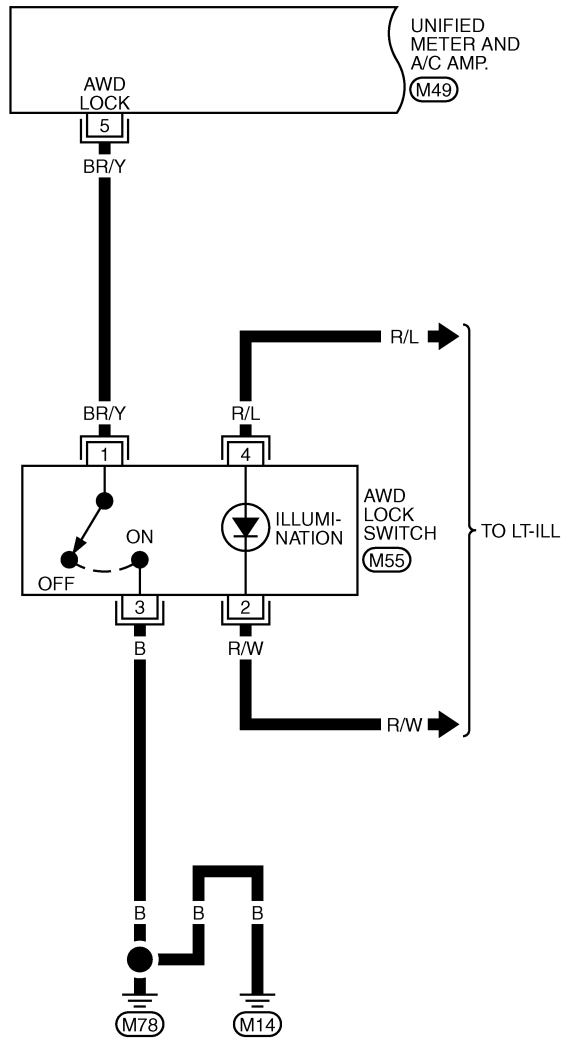

(M49)
GR

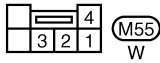

(M55)
W

TDWB0015E

TROUBLE DIAGNOSIS

TF-AWD-03

▬ : DATA LINE

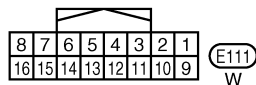
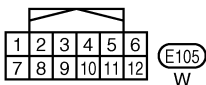
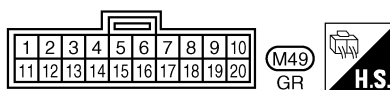
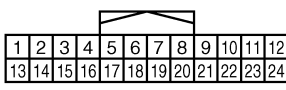
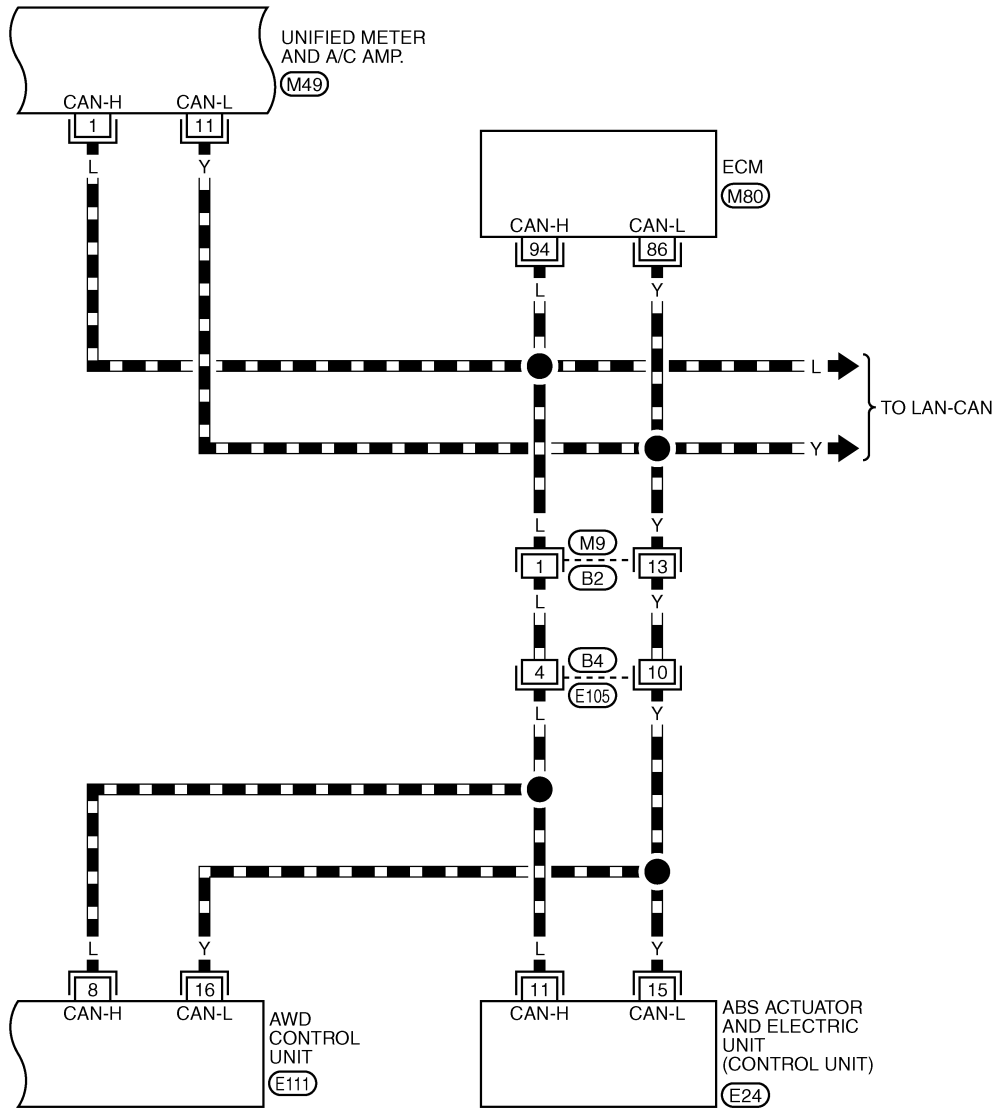

REFER TO THE FOLLOWING.
 (M80), (E24) -ELECTRICAL UNITS

TDWB0016E

TROUBLE DIAGNOSIS

TF-AWD-04

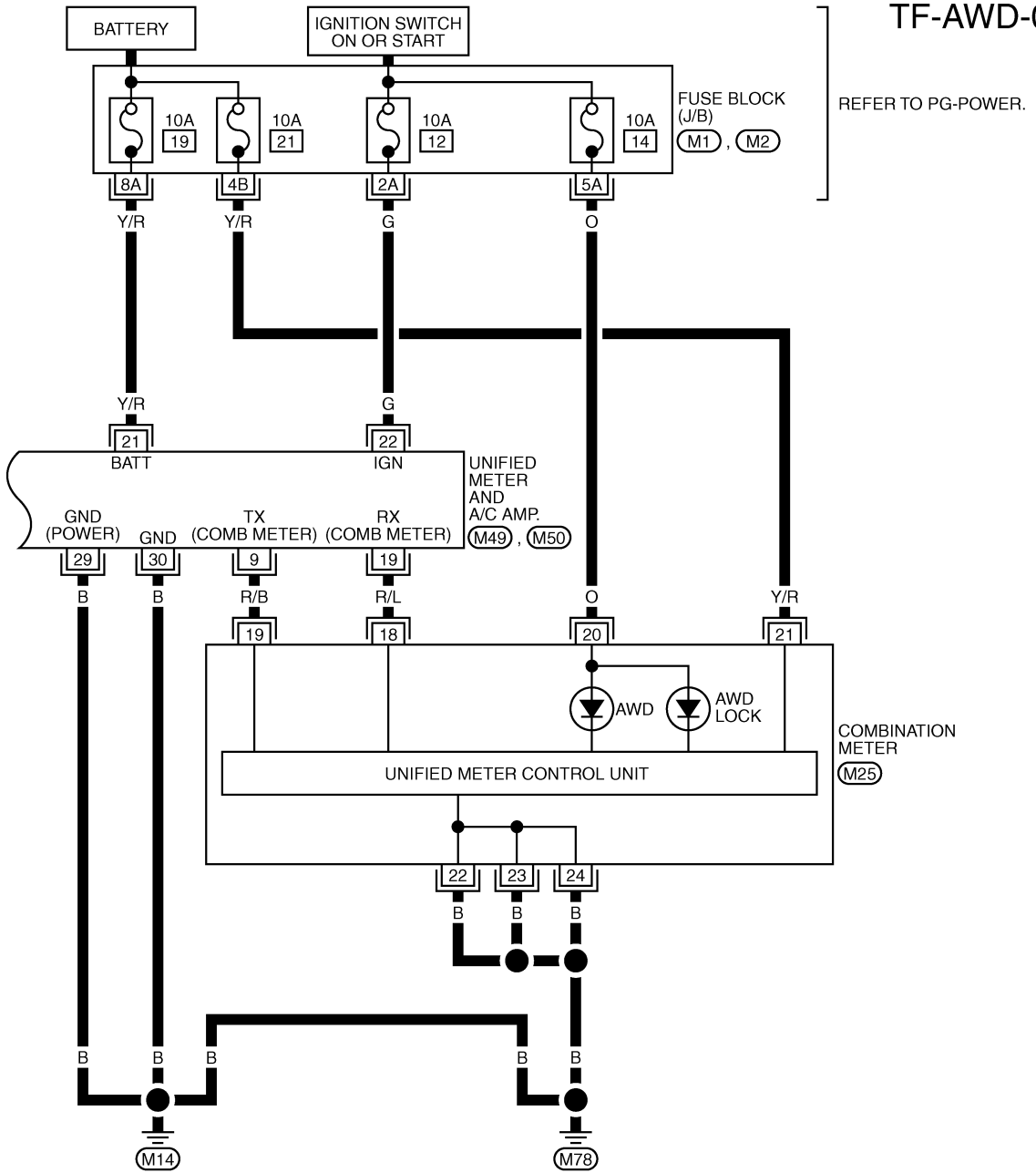

REFER TO PG-POWER.

REFER TO THE FOLLOWING.
 (M1), (M2) - FUSE BLOCK-
 JUNCTION BOX (J/B)

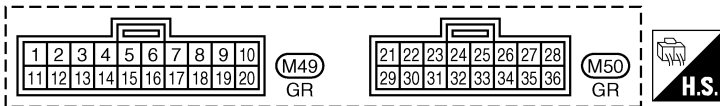
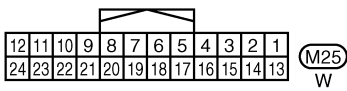

TDWB0017E

TROUBLE DIAGNOSIS

Trouble Diagnosis Chart for Symptoms

ADS000VG

If AWD warning lamp turns ON, perform self-diagnosis. Refer to [TF-25, "SELF-DIAG RESULT MODE"](#) .

Symptom	Condition	Check item	Reference page
AWD LOCK indicator lamp does not turn ON for approx. 1 second when the ignition switch is turned to ON. (AWD LOCK indicator lamp check)	Ignition switch: ON	CAN communication line	TF-38
		Power supply and ground for AWD control unit	
		Unified meter and A/C amp.	
		Unified meter control unit	
AWD warning lamp does not turn ON when the ignition switch is turned to ON. (AWD warning lamp check)	Ignition switch: ON	CAN communication line	TF-40
		Unified meter and A/C amp.	
		Unified meter control unit	
AWD warning lamp does not turn OFF several seconds after engine started.	Engine running	CAN communication line	TF-41
		Power supply and ground for AWD control unit	
		Unified meter and A/C amp.	
		Unified meter control unit	
		AWD solenoid	
		AWD actuator relay (integrated in AWD control unit)	
		Wheel sensor	
AWD mode cannot be switched after engine is started.	Engine running	AWD lock switch	TF-43
		CAN communication line	
		Unified meter and A/C amp.	
		Unified meter control unit	
Heavy tight-corner braking symptom occurs when the vehicle is driven in AUTO mode and the steering wheel is turned fully to either side after the engine is started. (See NOTE.)	<ul style="list-style-type: none"> ● While driving ● AUTO mode ● Steering wheel is turned fully to either sides 	CAN communication line	TF-45
		AWD lock switch	
		Accelerator pedal position signal	
		AWD solenoid	
		Mechanical malfunction of electric controlled coupling (clutch sticking etc.)	
Vehicle does not enter AWD mode even though AWD warning lamp turned to OFF.	Vehicle speed: 10 km/h (6 MPH) or less	AWD solenoid	TF-46
		Mechanical malfunction of electric controlled coupling (Mechanical engagement of clutch is not possible.)	
	Vehicle speed: 10 km/h (6 MPH) or more	Operating condition of parking brake	
		AWD solenoid	
		Mechanical malfunction of electric controlled coupling (Mechanical engagement of clutch is not possible.)	
While driving, AWD warning lamp flashes rapidly. (When flashing in approx. 1 minute and then turning OFF.) Rapid flashing: 2 times/second	While driving	Protection function is activated due to heavy load to electric controlled coupling. (AWD system is not malfunctioning.)	TF-47
While driving, AWD warning lamp flashes slowly. (When continuing to flash until turning ignition switch OFF) Slow flashing: 1 time/2 seconds	<ul style="list-style-type: none"> ● While driving ● Vehicle speed: 20 km/h (12 MPH) or more 	Tire size is different between front and rear of vehicle.	TF-47

NOTE:

- Light tight-corner braking symptom may occur depending on driving conditions in AUTO mode. This is not malfunction.
- Heavy tight-corner braking symptom occurs when vehicle is driven in the following conditions: LOCK mode, steering wheel is turned fully to either sides, and accelerator pedal is depressed.

TROUBLE DIAGNOSIS

AWD Control Unit Input/Output Signal Reference Values

ADS000WM

AWD CONTROL UNIT INSPECTION TABLE

Specifications with CONSULT-II

Monitored item [Unit]	Content	Condition	Display value	
FR RH SENSOR [km/h] or [mph]	Wheel speed (Front wheel right)	Vehicle stopped	0.00 km/h (0.00 mph)	
		Vehicle running CAUTION: Check air pressure of tire under standard condition.	Approximately equal to the indication on speedometer (Inside of ±10%)	
FR LH SENSOR [km/h] or [mph]	Wheel speed (Front wheel left)	Vehicle stopped	0.00 km/h (0.00 mph)	
		Vehicle running CAUTION: Check air pressure of tire under standard condition.	Approximately equal to the indication on speedometer (Inside of ±10%)	
RR RH SENSOR [km/h] or [mph]	Wheel speed (Rear wheel right)	Vehicle stopped	0.00 km/h (0.00 mph)	
		Vehicle running CAUTION: Check air pressure of tire under standard condition.	Approximately equal to the indication on speedometer (Inside of ±10%)	
RR LH SENSOR [km/h] or [mph]	Wheel speed (Rear wheel left)	Vehicle stopped	0.00 km/h (0.00 mph)	
		Vehicle running CAUTION: Check air pressure of tire under standard condition.	Approximately equal to the indication on speedometer (Inside of ±10%)	
BATTERY VOLT [V]	Power supply voltage for AWD control unit	Ignition switch: ON	Battery voltage	
THRTL POS SEN [%]	Throttle opening condition	When depressing accelerator pedal (Value rises gradually in response to throttle position.)	0 - 100%	
ETS SOLENOID [A]	Monitored value of current at AWD solenoid	Engine speed : At idle	AUTO	Approx. 0.000A
			LOCK	Approx. 0.000A
		Engine speed : 3,000 rpm or more constant	AUTO	Approx. 0.000 - 0.500A*
			LOCK	Approx. 1.800A
STOP LAMP SW [ON/OFF]	Condition of brake pedal operation	Brake pedal: Depressed	ON	
		Brake pedal: Released	OFF	
ENG SPEED SIG [RUN/STOP]	Condition of engine running	Engine stopped (Engine speed: Less than 400 rpm)	STOP	
		Engine running (Engine speed: 400 rpm or more)	RUN	
ETS ACTUATOR [ON/OFF]	Operating condition of AWD actuator relay (integrated in AWD control unit)	Engine stopped (Ignition switch: ON)	OFF	
		Engine running	ON	
4WD WARN LAMP [ON/OFF]	AWD warning lamp condition	AWD warning lamp: ON	ON	
		AWD warning lamp: OFF	OFF	
4WD MODE SW [ON/OFF]	Input condition from AWD lock switch	AWD lock switch	OFF	OFF
			ON	ON
4WD MODE MON [AUTO/LOCK]	Control status of AWD (Output condition of AWD LOCK indicator lamp signal)	AWD LOCK indicator lamp (Engine running)	OFF	AUTO
			ON	LOCK

TROUBLE DIAGNOSIS

Monitored item [Unit]	Content	Condition	Display value
DIS-TIRE MONI [mm]	Improper size tire installed condition	Vehicle running with normal size tire installed	0-4 mm
		Vehicle running with improper size tire installed (Front/rear tire size difference, wear condition)	4-8 mm, 8- mm
P BRAKE SW [ON/OFF]	Condition of parking brake	Parking brake operated	ON
		Parking brake not operated	OFF

*: The values are changed by throttle opening and engine speed.

CONSULT-II Function (ALL MODE AWD/4WD) FUNCTION

ADS000WN

CONSULT-II can display each diagnostic item using the diagnostic test modes shown following.

Diagnostic test mode	Function	Reference page
Self-diagnostic results	● Self-diagnostic results can be read and erased quickly.	TF-25
Data monitor	● Input/Output data in the AWD control unit can be read.	TF-26
CAN diagnostic support monitor	● The results of transmit/receive diagnosis of CAN communication can be read.	LAN-19
Active test	● Diagnostic Test Mode in which CONSULT-II drives some actuators apart from the AWD control unit and also shifts some parameters in a specified range.	TF-27
ECU part number	● AWD control unit part number can be read.	TF-27

CONSULT-II SETTING PROCEDURE

CAUTION:

If CONSULT-II is used with no connection of CONSULT-II CONVERTER, malfunctions might be detected in self-diagnosis depending on control unit which carry out CAN communication.

- For details, refer to the separate "CONSULT-II Operations Manual".

1. Turn ignition switch "OFF".
2. Connect CONSULT-II and CONSULT-II CONVERTER to data link connector on vehicle.
3. Turn ignition switch "ON".

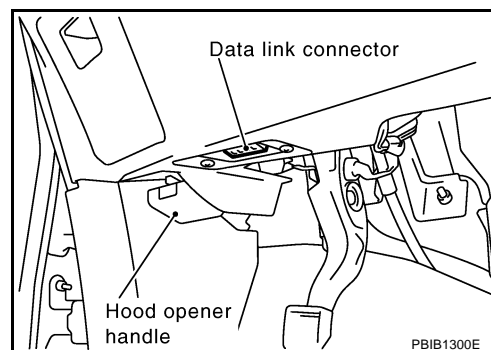

4. Touch "START (NISSAN BASED VHCL)".

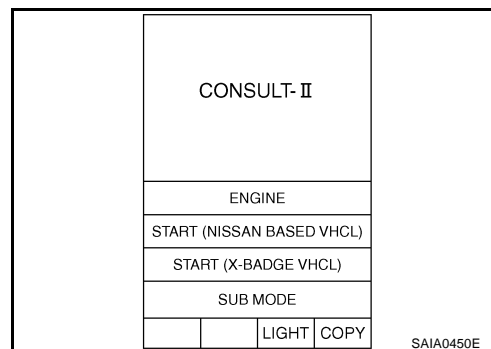

TROUBLE DIAGNOSIS

5. Touch "ALL MODE AWD/4WD".
If "ALL MODE AWD/4WD" is not indicated, go to [GI-39, "CONSULT-II Data Link Connector \(DLC\) Circuit"](#).
6. Perform each diagnostic test mode according to each service procedure.

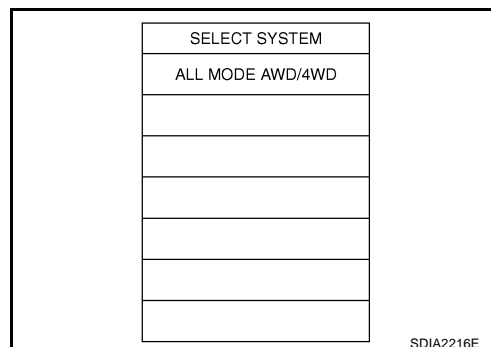

A
B
C

TF

SELF-DIAG RESULT MODE

Operation Procedure

1. Perform "CONSULT-II SETTING PROCEDURE". Refer to [TF-24, "CONSULT-II SETTING PROCEDURE"](#).
2. Start engine and drive at 30 km/h (19 MPH) or more for approx. 1 minute.
3. Stop vehicle. With engine at idle, touch "SELF-DIAG RESULTS". Display shows malfunction experienced since the last erasing operation.

NOTE:

- "TIME" shows the status of self-diagnosis results:
 - "0": Error is currently detected with AWD control unit.
 - Except for "0": Error was detected in the past and memorized in AWD control unit.
- "TIME" means the frequency of driving after DTC had occurred (frequency of turning ignition switch "ON/OFF").

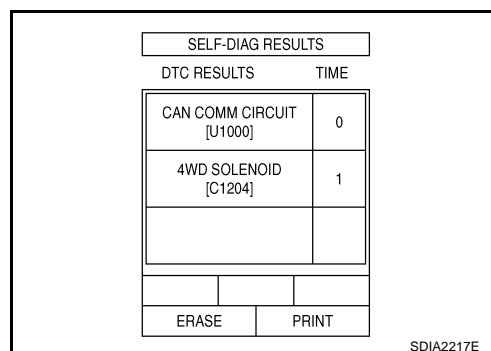

F
G
H
I

Display Item List

Items (CONSULT-II screen terms)	Diagnostic item is detected when...	Check item
CONTROLLER FAILURE [C1201]	Malfunction has occurred inside AWD control unit.	TF-29, "AWD Control Unit"
ABS SYSTEM [C1203]	Malfunction related to wheel sensor has been detected by ABS actuator and electric unit (control unit).	TF-29, "ABS System"
4WD SOLENOID [C1204]	Malfunction related to AWD solenoid has been detected.	TF-30, "AWD Solenoid"
4WD ACTUATOR RLY [C1205]	Malfunction has been detected from AWD actuator relay integrated with AWD control unit, or malfunction related to AWD solenoid has been detected.	TF-33, "AWD Actuator Relay" or TF-30, "AWD Solenoid"
ENGINE SIGNAL 1 [C1210]	Malfunction has been detected from ECM.	TF-36, "Engine Control Signal"
CAN COMM CIRCUIT [U1000]	Malfunction has been detected from CAN communication line.	TF-36, "CAN Communication Line"
NO DTC IS DETECTED. FURTHER TESTING MAY BE REQUIRED.	No NG item has been detected.	—

J
K
L
M

CAUTION:

- If "CAN COMM CIRCUIT [U1000]" is displayed with other DTCs, first perform the trouble diagnosis for CAN communication line.
- Make sure that ABS warning lamp turns OFF by driving for a minute at vehicle speed of 30 km/h (19 MPH) or more after turning ignition switch "OFF", if AWD warning lamp turns ON with system malfunction of "ABS SYSTEM [C1203]". AWD warning lamp may not turn OFF if it is normal unless ignition switch is turned OFF once and engine restarts after that.

How to Erase Self-diagnostic Results

1. Perform applicable inspection of malfunctioning item and then repair or replace.

TROUBLE DIAGNOSIS

2. Start engine and drive at 30 km/h (19 MPH) or more for approx. 1 minute.
3. Make sure that ABS warning lamp turns OFF.

NOTE:

Make sure that ABS warning lamp turns OFF by driving for a minute at vehicle speed of 30 km/h (19 MPH) or more after turning ignition switch “OFF”, if AWD warning lamp turns ON with system malfunction of “ABS SYSTEM [C1203]”. AWD warning lamp may not turn OFF if it is normal unless ignition switch turns OFF once and engine restarts after that.

4. Turn ignition switch “OFF” to erase memory.
5. Start engine and select “SELF-DIAG RESULTS” mode for “ALL MODE AWD/4WD” with CONSULT-II.
6. Touch “ERASE” on CONSULT-II screen to erase DTC memory.

CAUTION:

If memory cannot be erased, perform applicably diagnosis.

7. Drive at 30 km/h (19 MPH) or more for approx. 1 minute. Be sure AWD warning lamp is OFF.

DATA MONITOR MODE

Operation Procedure

1. Perform “CONSULT-II SETTING PROCEDURE”. Refer to [TF-24, "CONSULT-II SETTING PROCEDURE"](#)
2. Touch “DATA MONITOR”.
3. Select from “SELECT MONITOR ITEM”, screen of data monitor mode is displayed.

NOTE:

When malfunction is detected, CONSULT-II performs REAL-TIME DIAGNOSIS. Also, any malfunction detected while in this mode will be displayed at real time.

Display Item List

×: Standard –: Not applicable

Monitored item (Unit)	Monitor item selection			Remarks
	ECU INPUT SIGNALS	MAIN SIGNALS	SELECTION FROM MENU	
FR RH SENSOR [km/h] or [mph]	×	×	×	Wheel speed calculated by front wheel sensor RH signal is displayed.
FR LH SENSOR [km/h] or [mph]	×	×	×	Wheel speed calculated by front wheel sensor LH signal is displayed.
RR RH SENSOR [km/h] or [mph]	×	×	×	Wheel speed calculated by rear wheel sensor RH signal is displayed.
RR LH SENSOR [km/h] or [mph]	×	×	×	Wheel speed calculated by rear wheel sensor LH signal is displayed.
BATTERY VOLT [V]	–	–	×	Power supply voltage for AWD control unit.
THRTL POS SEN [%]	–	–	×	Throttle opening status is displayed.
ETS SOLENOID [A]	–	–	×	Monitored value of current at AWD solenoid.
STOP LAMP SW [ON/OFF]	–	–	×	Stop lamp switch signal status via CAN communication line is displayed.
ENG SPEED SIG [RUN/STOP]	–	–	×	Engine status is displayed.
ETS ACTUATOR [ON/OFF]	–	–	×	Operating condition of AWD actuator relay (integrated in AWD control unit) is displayed.
4WD WARN LAMP [ON/OFF]	–	–	×	Control status of AWD warning lamp is displayed.
4WD MODE SW [ON/OFF]	–	–	×	AWD lock switch signal status via CAN communication line is displayed.
4WD MODE MON [AUTO/LOCK]	–	–	×	Control status of AWD is displayed. (Output condition of AWD LOCK indicator lamp signal)

TROUBLE DIAGNOSIS

Monitored item (Unit)	Monitor item selection			Remarks
	ECU INPUT SIGNALS	MAIN SIGNALS	SELECTION FROM MENU	
DIS-TIRE MONI [mm]	–	–	×	Improper size tire installed condition is displayed.
P BRAKE SW [ON/OFF]	–	–	×	Parking switch signal status via CAN communication line is displayed.
Voltage [V]	–	–	×	The value measured by the voltage probe is displayed.
Frequency [Hz]	–	–	×	The value measured by the pulse probe is displayed.
DUTY-HI (high) [%]	–	–	×	
DUTY-LOW (low) [%]	–	–	×	
PLS WIDTH-HI [msec]	–	–	×	
PLS WIDTH-LOW [msec]	–	–	×	

ACTIVE TEST MODE

Description

Use this mode to determine and identify the details of a malfunction based on self-diagnostic results or data monitor. AWD control unit gives drive signal to actuator with receiving command from CONSULT-II to check operation of actuator.

Test Item

Test item	Condition	Description
ETS S/V (Detects AWD solenoid valve)	<ul style="list-style-type: none"> ● Vehicle stopped ● Engine running ● No DTC detected 	<ul style="list-style-type: none"> ● Change command current value to AWD solenoid, and then change driving mode. (Monitor value is normal if it is within approximately $\pm 10\%$ of command value.) <p>Qu: Increase current value in increments of 0.20A Qd: Decrease current value in increments of 0.20A UP: Increase current value in increments of 0.02A DOWN: Decrease current value in increments of 0.02A</p>

CAUTION:

Do not continuously energize for a long time.

AWD CONTROL UNIT PART NUMBER

Ignore the AWD control unit part number displayed in the "ECU PART NUMBER". Refer to parts catalog to order the AWD control unit.

TROUBLE DIAGNOSIS FOR SYSTEM

TROUBLE DIAGNOSIS FOR SYSTEM

PFP:00000

Power Supply Circuit For AWD Control Unit CONSULT-II REFERENCE VALUE IN DATA MONITOR MODE

ADS000W0

Data are reference value.

Monitored item [Unit]	Condition	Display value (Approx.)
BATTERY VOLT [V]	Ignition switch: ON	Battery voltage

DIAGNOSTIC PROCEDURE

1. CHECK POWER SUPPLY

1. Turn ignition switch "OFF".
2. Disconnect AWD control unit harness connector.
3. Turn ignition switch "ON". (Do not start engine.)
4. Check voltage between AWD control unit harness connector terminals and ground.

Connector	Terminal (Wire color)	Voltage (Approx.)
E111	7 (GR) - Ground	Battery voltage
	9 (G/R) - Ground	

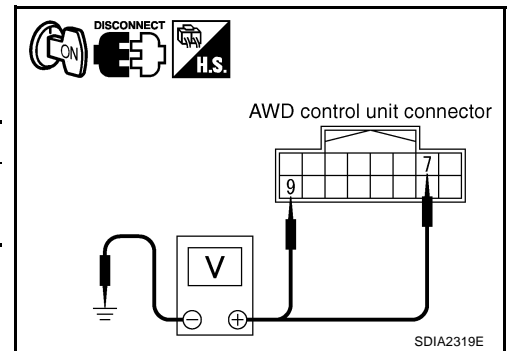

5. Turn ignition switch "OFF".
6. Check voltage between AWD control unit harness connector terminals and ground.

Connector	Terminal (Wire color)	Voltage (Approx.)
E111	7 (GR) - Ground	0V
	9 (G/R) - Ground	Battery voltage

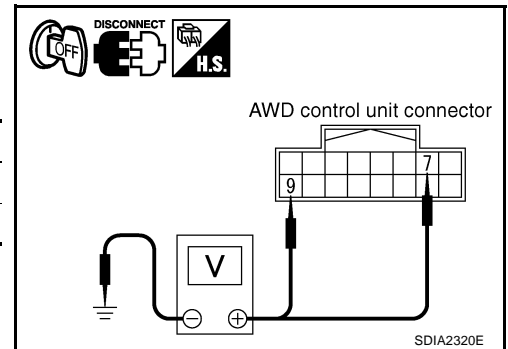

OK or NG

OK >> GO TO 2.

NG >> Check the following. If any items are damaged, repair or replace damaged parts.

- 10A fuse [No. 37, located in the fuse and fusible link block or No. 82, located in the IPDM E/R]
- Harness for short or open between battery and AWD control unit harness connector terminal 9
- Harness for short or open between ignition switch and AWD control unit harness connector terminal 7
- Ignition switch. Refer to [PG-3, "POWER SUPPLY ROUTING CIRCUIT"](#) .

TROUBLE DIAGNOSIS FOR SYSTEM

2. CHECK GROUND CIRCUIT

1. Turn ignition switch "OFF".
2. Disconnect AWD control unit harness connector.
3. Check continuity between AWD control unit harness connector E111 terminals 10 (B), 11 (B) and ground.

Continuity should exist.

Also check harness for short to ground and short to power.

OK or NG

OK >> GO TO 3.

NG >> Repair open circuit or short to ground or short to power in harness or connectors.

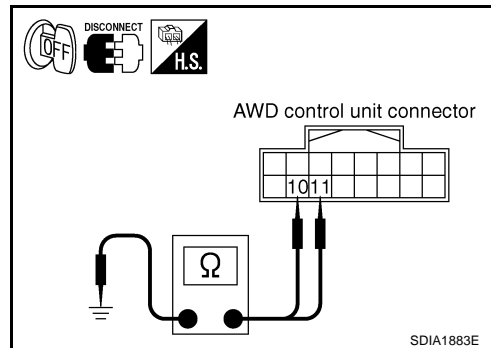

3. CHECK DTC

Start engine.

Does AWD warning lamp turn OFF?

YES >> **INSPECTION END**

NO >> Perform the self-diagnosis, repair or replace damaged parts. Refer to [TF-25, "SELF-DIAG RESULT MODE"](#).

AWD Control Unit DIAGNOSTIC PROCEDURE

ADS000WP

- Check the following if "CONTROLLER FAILURE [C1201]" is displayed in self-diagnostic results of CONSULT-II.

1. PERFORM SELF-DIAGNOSIS

With CONSULT-II

1. Turn ignition switch "ON". (Do not start engine.)
2. Select "SELF-DIAG RESULTS" mode for "ALL MODE AWD/4WD" with CONSULT-II.
3. Touch "ERASE".
4. Turn ignition switch "OFF" and wait at least 10 seconds.
5. Perform the self-diagnosis again.

Is the "CONTROLLER FAILURE [C1201]" displayed?

YES >> Replace AWD control unit. Refer to [TF-49, "AWD CONTROL UNIT"](#).

NO >> **INSPECTION END**

ABS System DIAGNOSTIC PROCEDURE

ADS000WQ

- Check the following if "ABS SYSTEM [C1203]" is displayed in self-diagnostic results of CONSULT-II.

1. CHECK DTC WITH ABS ACTUATOR AND ELECTRIC UNIT (CONTROL UNIT)

Perform self-diagnosis with ABS actuator and electric unit (control unit). Refer to [BRC-22, "SELF-DIAGNOSIS"](#) (without VDC) or [BRC-72, "SELF-DIAGNOSIS"](#) (with VDC).

Is any malfunction detected by self-diagnosis?

YES >> Check the malfunctioning system.

NO >> GO TO 2.

TROUBLE DIAGNOSIS FOR SYSTEM

2. CHECK DTC AFTER DRIVING

1. Turn ignition switch "OFF".
2. Start engine and drive vehicle at 30 km/h (19 MPH) for at least 1 minute.
3. Make sure that ABS warning lamp turns OFF.
4. Erase self-diagnostic results. Refer to [TF-25, "How to Erase Self-diagnostic Results"](#) .
5. Stop vehicle and turn ignition switch "OFF".
6. Turn ignition switch "ON".
7. Perform self-diagnosis.

Is the "ABS SYSTEM [C1203]" displayed?

- YES >> GO TO 3.
NO >> **INSPECTION END**

3. CHECK AWD CONTROL UNIT

Check AWD control unit input/output signal. Refer to [TF-23, "AWD Control Unit Input/Output Signal Reference Values"](#) .

OK or NG

- OK >> GO TO 4.
NG >> Check AWD control unit pin terminals for damage or loose connection with harness connector. If any items are damaged, repair or replace damaged parts.

4. CHECK DTC

Perform the self-diagnosis, after driving a vehicle for a while.

OK or NG

- OK >> **INSPECTION END**
NG >> Perform self-diagnosis with ABS actuator and electric unit (control unit) again. Refer to [BRC-22, "SELF-DIAGNOSIS"](#) (without VDC) or [BRC-72, "SELF-DIAGNOSIS"](#) (with VDC).

AWD Solenoid CONSULT-II REFERENCE VALUE IN DATA MONITOR MODE

ADS000WR

Data are reference value.

Monitored item [Unit]	Condition	Display value	
ETS SOLENOID [A]	Engine speed: At idle	AUTO mode	Approx. 0.000A
		LOCK mode	
	Engine speed: 3,000 rpm or more constant	AUTO mode	Approx. 0.000 - 0.500A*
		LOCK mode	Approx. 1.800A

*: The values are changed by throttle opening and engine speed.

TROUBLE DIAGNOSIS FOR SYSTEM

DIAGNOSTIC PROCEDURE

- Check the following if "4WD SOLENOID [C1204]" is displayed in self-diagnostic results of CONSULT-II.

1. CHECK AWD SOLENOID SIGNAL

With CONSULT-II

1. Start engine.
2. Select "DATA MONITOR" mode for "ALL MODE AWD/4WD" with CONSULT-II.
3. Read out the value of "ETS SOLENOID".

Condition		Display value
Engine speed: At idle	AUTO mode	Approx. 0.000A
	LOCK mode	
Engine speed: 3,000 rpm or more constant	AUTO mode	Approx. 0.000 - 0.500A*
	LOCK mode	

*: The values are changed by throttle opening and engine speed.

OK or NG

- OK >> GO TO 6.
 NG >> GO TO 2.

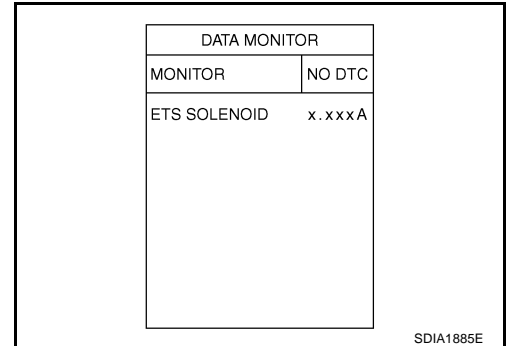

2. CHECK POWER SUPPLY

1. Turn ignition switch "OFF".
2. Disconnect AWD control unit harness connector.
3. Turn ignition switch "ON". (Do not start engine.)
4. Check voltage between AWD control unit harness connector terminal 9 and ground.

Connector	Terminal (Wire color)	Voltage (Approx.)
E111	9 (G/R) - Ground	Battery voltage

OK or NG

- OK >> GO TO 3.
 NG >> Check the following. If any items are damaged, repair or replace damaged parts.
- 10A fuse [No. 37, located in the fuse and fusible link block]
 - Harness for short or open between battery and AWD control unit harness connector terminal 9

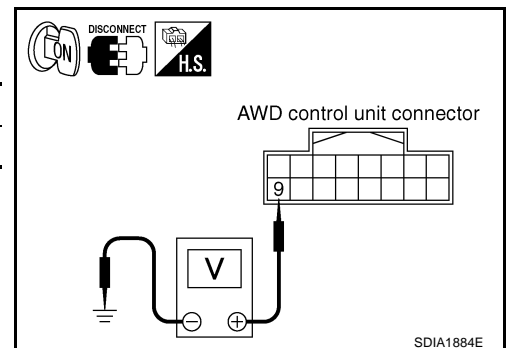

3. CHECK AWD SOLENOID CIRCUIT

1. Turn ignition switch "OFF".
2. Disconnect AWD control unit harness connector.
3. Check resistance between AWD control unit harness connector terminals 1 and 2.

Connector	Terminal (Wire color)	Resistance (Approx.)
E111	1 (LG) - 2 (L/W) (Ground)	2.45 Ω

OK or NG

- OK >> GO TO 6.
 NG >> GO TO 4.

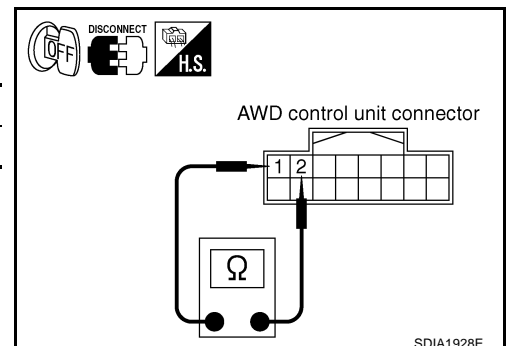

TROUBLE DIAGNOSIS FOR SYSTEM

4. CHECK AWD SOLENOID

1. Turn ignition switch "OFF".
2. Disconnect AWD solenoid valve harness connector.
3. Check resistance between AWD solenoid valve harness connector B204 terminals 1 and 2.

1 - 2 : Approx. 2.45Ω

OK or NG

OK >> GO TO 5.

NG >> AWD solenoid is malfunctioning. Replace electric controlled coupling. Refer to [RFD-16, "Disassembly and Assembly"](#).

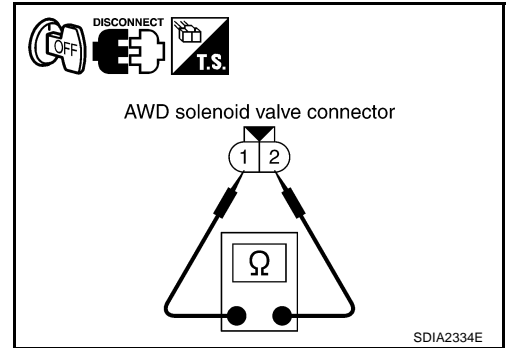

5. CHECK HARNESS BETWEEN AWD CONTROL UNIT AND AWD SOLENOID

1. Turn ignition switch "OFF".
2. Disconnect AWD control unit harness connector and AWD solenoid valve harness connector.
3. Check continuity between the following terminals.
 - AWD control unit harness connector E111 terminal 1 (LG) and AWD solenoid valve harness connector B204 terminal 1 (LG).
 - AWD control unit harness connector E111 terminal 2 (L/W) and AWD solenoid valve harness connector B204 terminal 2 (L/W).

1 (LG) - 1 (LG) : Continuity should exist.

2 (L/W) - 2 (L/W) : Continuity should exist.

Also check harness for short to ground and short to power.

OK or NG

OK >> GO TO 6.

NG >> Repair or replace damaged parts.

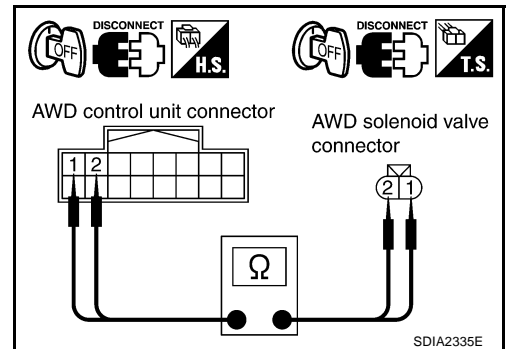

6. CHECK AWD CONTROL UNIT

Check AWD control unit input/output signal. Refer to [TF-23, "AWD Control Unit Input/Output Signal Reference Values"](#).

OK or NG

OK >> GO TO 7.

NG >> Check AWD control unit pin terminals for damage or loose connection with harness connector. If any item is damaged, repair or replace damaged parts.

7. CHECK DTC

Perform the self-diagnosis, after driving a vehicle for a while.

OK or NG

OK >> **INSPECTION END**

NG >> Replace AWD control unit.

COMPONENT INSPECTION

1. Turn ignition switch "OFF".
2. Disconnect AWD solenoid valve harness connector.

TROUBLE DIAGNOSIS FOR SYSTEM

3. Check resistance between AWD solenoid valve harness connector B204 terminals 1 and 2.

1 - 2 : Approx. 2.45Ω

4. If NG, replace electric controlled coupling. Refer to [RFD-16, "Disassembly and Assembly"](#).

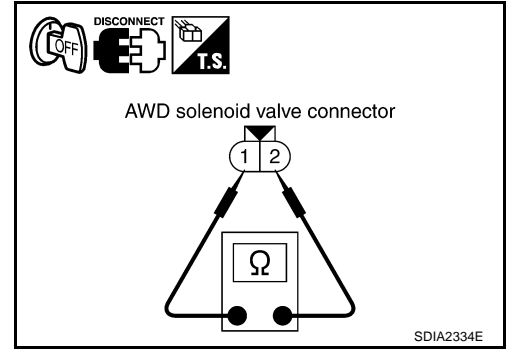

ADS000WS

AWD Actuator Relay CONSULT-II REFERENCE VALUE IN DATA MONITOR MODE

Data are reference value.

Monitored item	Condition	Display value
ETS ACTUATOR [ON/OFF]	Engine stopped (Ignition switch: ON)	OFF
	Engine running	ON

DIAGNOSTIC PROCEDURE

- Check the following if "4WD ACTUATOR RLY [C1205]" is displayed in self-diagnostic results of CONSULT-II.

1. CHECK AWD SOLENOID SYSTEM

Perform self-diagnosis. Refer to [TF-25, "SELF-DIAG RESULT MODE"](#).

Is the "4WD SOLENOID [C1204]" displayed?

- YES >> Perform trouble diagnosis for AWD solenoid. Refer to [TF-30, "AWD Solenoid"](#).
 NO >> GO TO 2.

2. CHECK AWD ACTUATOR RELAY SIGNAL

With CONSULT-II

- Turn ignition switch "ON". (Do not start engine.)
- Select "DATA MONITOR" mode for "ALL MODE AWD/4WD" with CONSULT-II.
- Start engine and read out ON/OFF signal of "ETS ACTUATOR".

Monitor item	Condition	Display value
ETS ACTUATOR	Engine stopped (Ignition switch: ON)	OFF
	Engine running	ON

OK or NG

- OK >> GO TO 4.
 NG >> GO TO 3.

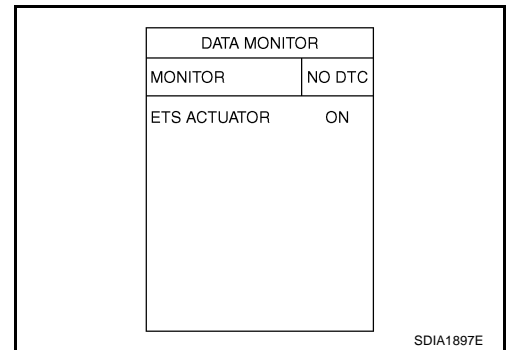

3. CHECK AWD CONTROL UNIT

Check AWD control unit input/output signal. Refer to [TF-23, "AWD Control Unit Input/Output Signal Reference Values"](#).

OK or NG

- OK >> GO TO 4.
 NG >> Check AWD control unit pin terminals for damage or loose connection with harness connector. If any item is damaged, repair or replace damaged parts.

TROUBLE DIAGNOSIS FOR SYSTEM

4. CHECK DTC

Perform the self-diagnosis, after driving a vehicle for a while.

OK or NG

- OK >> **INSPECTION END**
- NG >> Replace AWD control unit.

AWD Lock Switch CONSULT-II REFERENCE VALUE IN DATA MONITOR MODE

ADS000VP

Data are reference value.

Monitored item	Condition		Display value
4WD MODE SW [ON/OFF]	AWD lock switch	OFF	OFF
		ON	ON

DIAGNOSTIC PROCEDURE

1. CHECK AWD LOCK SWITCH SIGNAL

 **With CONSULT-II**

- Turn ignition switch "ON".
- Select "DATA MONITOR" mode for "ALL MODE AWD/4WD" with CONSULT-II.
- Read out monitor "4WD MODE SW" with operating AWD lock switch.

Monitor item	Condition		Display value
4WD MODE SW	AWD lock switch	OFF	OFF
		ON	ON

OK or NG

- OK >> GO TO 6.
- NG >> GO TO 2.

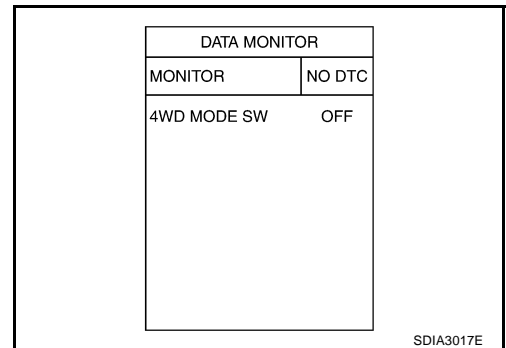

2. CHECK INPUT SIGNAL WITH UNIFIED METER AND A/C AMP.

 **With CONSULT-II**

- Turn ignition switch "ON".
- Select "DATA MONITOR" mode for "METER A/C AMP" with CONSULT-II.
- Read out monitor "4WD LOCK SW" with operating AWD lock switch.

Monitor item	Condition		Display value
4WD LOCK SW	AWD lock switch	OFF	OFF
		ON	ON

OK or NG

- OK >> GO TO 6.
- NG >> GO TO 3.

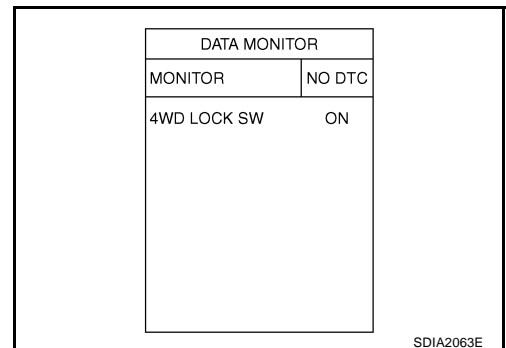

TROUBLE DIAGNOSIS FOR SYSTEM

3. CHECK AWD LOCK SWITCH CIRCUIT

1. Turn ignition switch "OFF".
2. Disconnect unified meter and A/C amp. harness connector.
3. Operate AWD lock switch and check continuity between unified meter and A/C amp. harness connector M49 terminal 5 (BR/Y) and ground.

Connector	Terminal (Wire color)	Condition	Continuity
M49	5 (BR/Y) - Ground	AWD lock switch: "ON" position	Yes
		AWD lock switch: "OFF" position	No

OK or NG

- OK >> GO TO 6.
 NG >> GO TO 4.

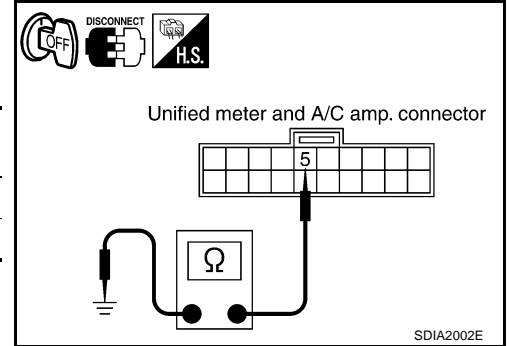

4. CHECK AWD LOCK SWITCH

1. Turn ignition switch "OFF".
2. Disconnect AWD lock switch harness connector.
3. Operate AWD lock switch and check continuity between AWD lock switch harness connector M55 terminals 1 and 3.

Connector	Terminal	Condition	Continuity
M55	1 - 3	AWD lock switch: "ON" position	Yes
		AWD lock switch: "OFF" position	No

OK or NG

- OK >> GO TO 5.
 NG >> Replace AWD lock switch.

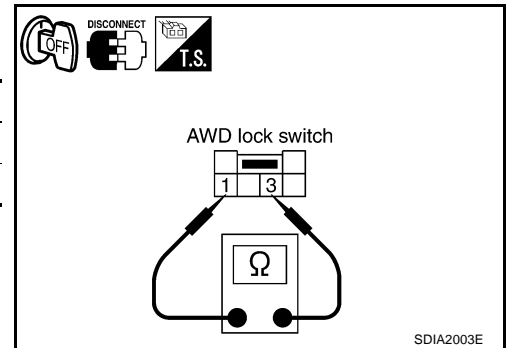

5. CHECK HARNESS BETWEEN UNIFIED METER AND A/C AMP. AND AWD LOCK SWITCH

1. Turn ignition switch "OFF".
2. Disconnect unified meter and A/C amp. harness connector and AWD lock switch harness connector.
3. Check continuity between unified meter and A/C amp. harness connector M49 terminal 5 (BR/Y) and AWD lock switch harness connector M55 terminal 1 (BR/Y).

Continuity should exist.

Also check harness for short to ground and short to power.

OK or NG

- OK >> GO TO 6.
 NG >> Repair or replace damaged parts.

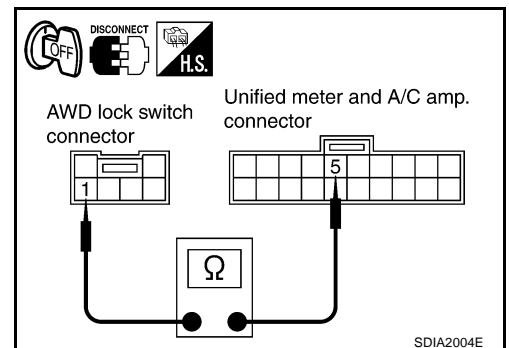

6. CHECK AWD CONTROL UNIT

Check AWD control unit input/output signal. Refer to [TF-23. "AWD Control Unit Input/Output Signal Reference Values"](#).

OK or NG

- OK >> GO TO 7.
 NG >> Check AWD control unit pin terminals for damage or loose connection with harness connector. If any item is damaged, repair or replace damaged parts.

TROUBLE DIAGNOSIS FOR SYSTEM

7. CHECK AWD LOCK INDICATOR LAMP

1. Turn ignition switch "OFF".
2. Check AWD LOCK indicator lamp "ON" for approx. 1 second when turned ignition switch "ON".

Does AWD LOCK indicator lamp "ON" for approx. 1 second?

YES >> **INSPECTION END**

NO >> Go to [TF-38, "AWD LOCK Indicator Lamp Does Not Turn ON for Approx. 1 Second When The Ignition Switch Is Turned to ON"](#) .

COMPONENT INSPECTION

1. Turn ignition switch "OFF".
2. Disconnect AWD lock switch harness connector.
3. Operate AWD lock switch and check continuity between AWD lock switch harness connector M55 terminals 1 and 3.

Connector	Terminal	Condition	Continuity
M55	1 - 3	AWD lock switch: "ON" position	Yes
		AWD lock switch: "OFF" position	No

4. If NG, replace AWD lock switch.

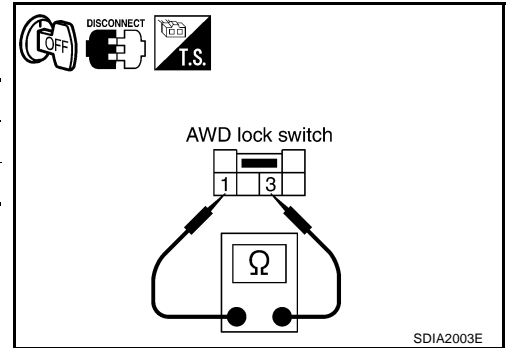

ADS001DS

Engine Control Signal DIAGNOSTIC PROCEDURE

- Check the following if "ENGINE SIGNAL 1 [C1210]" is displayed in self-diagnosis results of CONSULT-II.

1. CHECK DTC WITH ECM

Perform self-diagnosis with ECM. Refer to [EC-47, "Emission-Related Diagnostic Information"](#) .

Is any malfunction detected by self-diagnosis?

YES >> Check the malfunctioning system.

NO >> GO TO 2.

2. CHECK AWD CONTROL UNIT

Check AWD control unit input/output signal. Refer to [TF-23, "AWD Control Unit Input/Output Signal Reference Values"](#) .

OK or NG

OK >> GO TO 3.

NG >> Check AWD control unit pin terminals for damage or loose connection with harness connector. If any item is damaged, repair or replace damaged parts.

3. CHECK DTC

Perform the self-diagnosis, after driving a vehicle for a while.

OK or NG

OK >> **INSPECTION END**

NG >> Perform self-diagnosis with ECM again. Refer to [EC-47, "Emission-Related Diagnostic Information"](#) .

CAN Communication Line DIAGNOSTIC PROCEDURE

ADS000WT

- Check the following if "CAN COMM CIRCUIT [U1000]" is detected in self-diagnostic results of CONSULT-II.

TROUBLE DIAGNOSIS FOR SYSTEM

1. CHECK CAN COMMUNICATION CIRCUIT

① With CONSULT-II

1. Turn ignition switch "ON" and start engine.
2. Select "SELF-DIAG RESULTS" mode for "ALL MODE AWD/4WD" with in CONSULT-II.
3. Perform the self-diagnosis.

Is the "CAN COMM CIRCUIT [U1000]" displayed?

YES >> Print out CONSULT-II screen and go to [LAN-5, "Precautions When Using CONSULT-II"](#).

NO >> **INSPECTION END**

SELF-DIAG RESULTS	
DTC RESULTS	TIME
CAN COMM CIRCUIT [U1000]	0

ERASE PRINT

SDIA1850E

A
B
C
TF
E
F
G
H
I
J
K
L
M

TROUBLE DIAGNOSIS FOR SYMPTOMS

TROUBLE DIAGNOSIS FOR SYMPTOMS

PFP:00007

AWD LOCK Indicator Lamp Does Not Turn ON for Approx. 1 Second When The Ignition Switch Is Turned to ON DIAGNOSTIC PROCEDURE

ADS000VQ

1. CHECK SYSTEM FOR CAN COMMUNICATION LINE

Perform self-diagnosis. Refer to [TF-25, "SELF-DIAG RESULT MODE"](#) .

Is the "CAN COMM CIRCUIT [U1000]" displayed?

YES >> Perform trouble diagnosis for CAN communication line. Refer to [TF-36, "CAN Communication Line"](#) .

NO >> GO TO 2.

2. CHECK AWD CONTROL UNIT POWER SUPPLY CIRCUIT

1. Turn ignition switch "OFF".
2. Disconnect AWD control unit harness connector.
3. Turn ignition switch "ON". (Do not start engine.)
4. Check voltage between AWD control unit harness connector terminals and ground.

Connector	Terminal (Wire color)	Voltage (Approx.)
E111	7 (GR) - Ground	Battery voltage
	9 (G/R) - Ground	

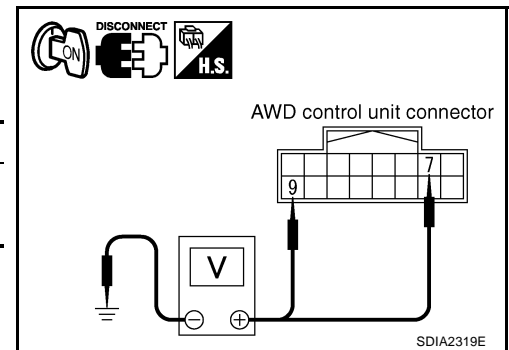

5. Turn ignition switch "OFF".
6. Check voltage between AWD control unit harness connector terminals and ground.

Connector	Terminal (Wire color)	Voltage (Approx.)
E111	7 (GR) - Ground	0V
	9 (G/R) - Ground	Battery voltage

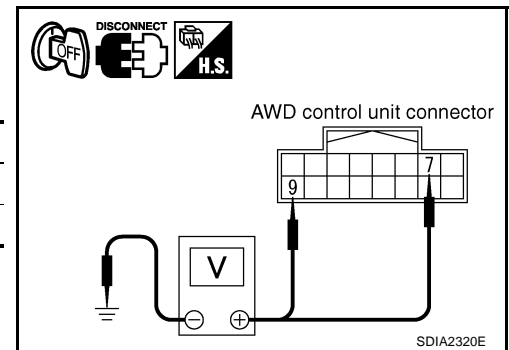

OK or NG

OK >> GO TO 3.

NG >> Check the following. If any items are damaged, repair or replace damaged parts.

- 10A fuse [No. 37, located in the fuse and fusible link block or No. 82, located in the IPDM E/R]
- Harness for short or open between battery and AWD control unit harness connector terminal 9
- Harness for short or open between ignition switch and AWD control unit harness connector terminal 7
- Ignition switch. Refer to [PG-3, "POWER SUPPLY ROUTING CIRCUIT"](#) .

TROUBLE DIAGNOSIS FOR SYMPTOMS

3. CHECK AWD CONTROL UNIT GROUND CIRCUIT

1. Turn ignition switch "OFF".
2. Disconnect AWD control unit harness connector.
3. Check continuity between AWD control unit harness connector E111 terminals 10 (B), 11 (B) and ground.

Continuity should exist.

Also check harness for short to ground and short to power.

OK or NG

OK >> GO TO 4.

NG >> Repair open circuit or short to ground or short to power in harness or connectors.

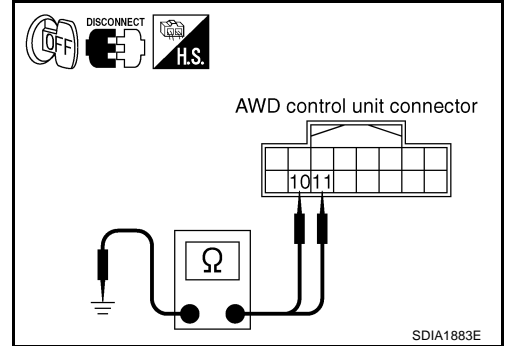

4. CHECK AWD CONTROL UNIT

Check AWD control unit input/output signal. Refer to [TF-23, "AWD Control Unit Input/Output Signal Reference Values"](#).

OK or NG

OK >> GO TO 5.

NG >> Check AWD control unit pin terminals for damage or loose connection with harness connector. If any item is damaged, repair or replace damaged parts.

5. CHECK INPUT SIGNAL WITH UNIFIED METER AND A/C AMP.

With CONSULT-II

1. Turn ignition switch "ON".
2. Select "DATA MONITOR" mode for "METER A/C AMP" with CONSULT-II.
3. Operate AWD lock switch and read out monitor "4WD LOCK SW".

Monitor item	Condition	Display value
4WD LOCK SW	AWD lock switch OFF	OFF
	AWD lock switch ON	ON

OK or NG

OK >> GO TO 6.

NG >> Perform trouble diagnosis for AWD lock switch. Refer to [TF-34, "AWD Lock Switch"](#).

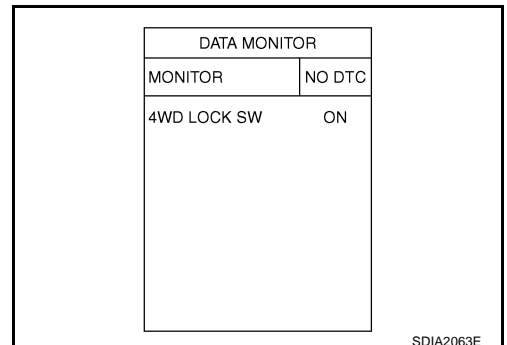

TROUBLE DIAGNOSIS FOR SYMPTOMS

6. CHECK OUTPUT SIGNAL WITH UNIFIED METER AND A/C AMP.

With CONSULT-II

1. Start engine.
2. Select "DATA MONITOR" mode for "METER A/C AMP" with CONSULT-II.
3. Operate AWD lock switch and read out monitor "4WD LOCK IND".

Monitor item	Condition	Display value
4WD LOCK IND	AWD lock switch OFF	OFF
	AWD lock switch ON	ON

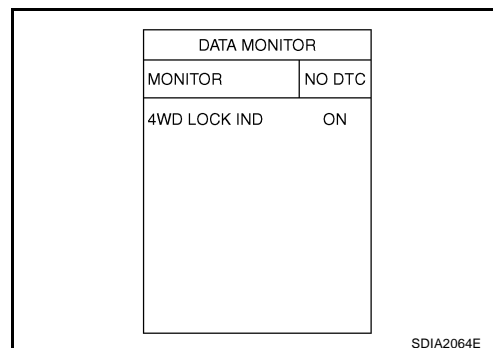

OK or NG

OK >> GO TO 7.

NG >> Perform trouble diagnosis for combination meter. Refer to [DI-15, "Trouble Diagnosis"](#).

7. SYMPTOM CHECK

Check again.

OK or NG

OK >> **INSPECTION END**

NG >> Replace unified meter control unit assembly. Refer to [DI-26, "Disassembly and Assembly of Combination Meter"](#).

AWD Warning Lamp Does Not Turn ON When The Ignition Switch Is Turned to ON

ADS000VR

DIAGNOSTIC PROCEDURE

1. CHECK SYSTEM FOR CAN COMMUNICATION LINE

Perform self-diagnosis. Refer to [TF-25, "SELF-DIAG RESULT MODE"](#).

Is the "CAN COMM CIRCUIT [U1000]" displayed?

YES >> Perform trouble diagnosis for CAN communication line. Refer to [TF-36, "CAN Communication Line"](#).

NO >> GO TO 2.

2. CHECK AWD CONTROL UNIT

Check AWD control unit input/output signal. Refer to [TF-23, "AWD Control Unit Input/Output Signal Reference Values"](#).

OK or NG

OK >> GO TO 3.

NG >> Check AWD control unit pin terminals for damage or loose connection with harness connector. If any item is damaged, repair or replace damaged parts.

TROUBLE DIAGNOSIS FOR SYMPTOMS

3. CHECK OUTPUT SIGNAL WITH UNIFIED METER AND A/C AMP.

With CONSULT-II

1. Turn ignition switch "ON". (Do not start engine.)
2. Select "DATA MONITOR" mode for "METER A/C AMP" with CONSULT-II.
3. Start the engine, and then make sure that "4WD W/L" display turns from "ON" to "OFF" after several seconds.

Monitor item	Condition	Display value
4WD W/L	Ignition switch ON	ON
	Start engine (after several seconds)	OFF

DATA MONITOR	
MONITOR	NO DTC
4WD W/L	OFF

SDIA2065E

OK or NG

- OK >> GO TO 4.
NG >> Perform trouble diagnosis for combination meter. Refer to [DI-15, "Trouble Diagnosis"](#) .

4. SYMPTOM CHECK

Check again.

OK or NG

- OK >> **INSPECTION END**
NG >> Replace unified meter control unit assembly. Refer to [DI-26, "Disassembly and Assembly of Combination Meter"](#) .

AWD Warning Lamp Does Not Turn OFF Several Seconds after Engine Started

ADS000VS

DIAGNOSTIC PROCEDURE

1. CHECK SELF-DIAGNOSTIC RESULTS

Perform self-diagnosis. Refer to [TF-25, "SELF-DIAG RESULT MODE"](#) .

Is any malfunction detected by self-diagnosis?

- YES >> Check the malfunctioning system.
NO >> GO TO 2.

TROUBLE DIAGNOSIS FOR SYMPTOMS

2. CHECK AWD CONTROL UNIT POWER SUPPLY CIRCUIT

1. Turn ignition switch "OFF".
2. Disconnect AWD control unit harness connector.
3. Turn ignition switch "ON". (Do not start engine.)
4. Check voltage between AWD control unit harness connector terminals and ground.

Connector	Terminal (Wire color)	Voltage (Approx.)
E111	7 (GR) - Ground	Battery voltage
	9 (G/R) - Ground	

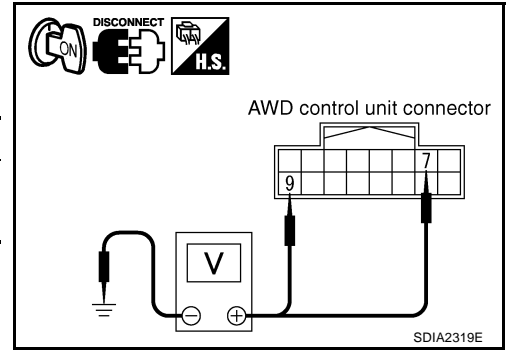

5. Turn ignition switch "OFF".
6. Check voltage between AWD control unit harness connector terminals and ground.

Connector	Terminal (Wire color)	Voltage (Approx.)
E111	7 (GR) - Ground	0V
	9 (G/R) - Ground	Battery voltage

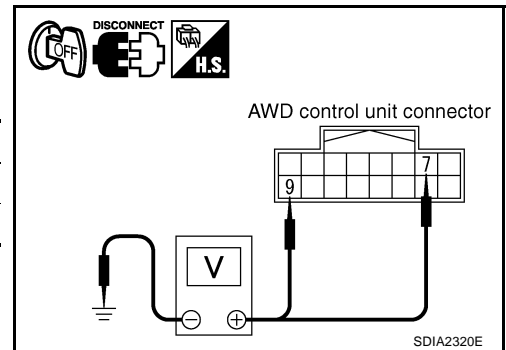

OK or NG

OK >> GO TO 3.

NG >> Check the following. If any item is damaged, repair or replace damaged parts.

- 10A fuse [No. 37, located in the fuse and fusible link block or No. 82, located in the IPDM E/R]
- Harness for short or open between battery and AWD control unit harness connector terminal 9
- Harness for short or open between ignition switch and AWD control unit harness connector terminal 7
- Ignition switch. Refer to [PG-3, "POWER SUPPLY ROUTING CIRCUIT"](#).

3. CHECK AWD CONTROL UNIT GROUND CIRCUIT

1. Turn ignition switch "OFF".
2. Disconnect AWD control unit harness connector.
3. Check continuity between AWD control unit harness connector E111 terminals 10 (B), 11 (B) and ground.

Continuity should exist.

Also check harness for short to ground and short to power.

OK or NG

OK >> GO TO 4.

NG >> Repair open circuit or short to ground or short to power in harness or connectors.

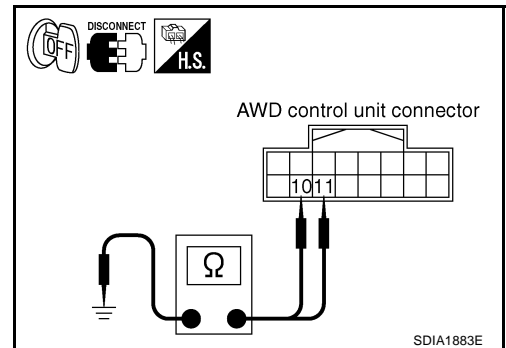

TROUBLE DIAGNOSIS FOR SYMPTOMS

4. CHECK AWD CONTROL UNIT

Check AWD control unit input/output signal. Refer to [TF-23, "AWD Control Unit Input/Output Signal Reference Values"](#) .

OK or NG

OK >> GO TO 5.

NG >> Check AWD control unit pin terminals for damage or loose connection with harness connector. If any item is damaged, repair or replace damaged parts.

5. CHECK OUTPUT SIGNAL WITH UNIFIED METER AND A/C AMP.

 With CONSULT-II

1. Turn ignition switch "ON". (Do not start engine.)
2. Select "DATA MONITOR" mode for "METER A/C AMP" with CONSULT-II.
3. Start the engine, and then make sure that "4WD W/L" display turns from "ON" to "OFF" after several seconds.

Monitor item	Condition	Display value
4WD W/L	Ignition switch ON	ON
	Start engine (after several seconds)	OFF

OK or NG

OK >> GO TO 6.

NG >> Perform trouble diagnosis for combination meter. Refer to [DI-15, "Trouble Diagnosis"](#) .

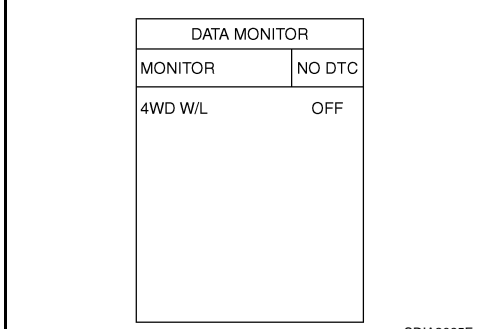

The screenshot shows a 'DATA MONITOR' window with two columns: 'MONITOR' and 'NO DTC'. The 'MONITOR' column displays '4WD W/L' and the 'NO DTC' column displays 'OFF'. The screen is labeled 'SDIA2065E' in the bottom right corner.

6. SYMPTOM CHECK

Check again.

OK or NG

OK >> **INSPECTION END**

NG >> Replace unified meter control unit assembly. Refer to [DI-26, "Disassembly and Assembly of Combination Meter"](#) .

AWD Mode Cannot Be Switched after Engine Is Started DIAGNOSTIC PROCEDURE

ADS000VT

1. CHECK AWD WARNING LAMP

Confirm AWD warning lamp.

Does AWD warning lamp turn on?

YES >> Go to [TF-41, "AWD Warning Lamp Does Not Turn OFF Several Seconds after Engine Started"](#) .

NO >> GO TO 2.

2. CHECK SYSTEM FOR AWD LOCK SWITCH

Perform trouble diagnosis for AWD lock switch system. Refer to [TF-34, "AWD Lock Switch"](#) .

OK or NG

OK >> GO TO 3.

NG >> Repair or replace damaged parts.

TROUBLE DIAGNOSIS FOR SYMPTOMS

3. CHECK CONTROL STATUS OF AWD

With CONSULT-II

1. Start engine.
2. Select "DATA MONITOR" mode for "ALL MODE AWD/4WD" with CONSULT-II.
3. Check AWD LOCK indicator lamp ON when operating AWD lock switch, and then readout monitor "4WD MODE MON".

Monitor item	Condition		Display value
4WD MODE MON	AWD LOCK indicator lamp	OFF	AUTO
		ON	LOCK

OK or NG

- OK >> GO TO 4.
NG >> GO TO 5.

DATA MONITOR	
MONITOR	NO DTC
4WD MODE MON	AUTO

SDIA2268E

4. CHECK OUTPUT SIGNAL WITH UNIFIED METER AND A/C AMP.

With CONSULT-II

1. Start engine.
2. Select "DATA MONITOR" mode for "METER A/C AMP" with CONSULT-II.
3. Operate AWD lock switch and read out monitor "4WD LOCK IND".

Monitor item	Condition		Display value
4WD LOCK IND	AWD lock switch	OFF	OFF
		ON	ON

OK or NG

- OK >> GO TO 5.
NG >> Perform trouble diagnosis for combination meter. Refer to [DI-15, "Trouble Diagnosis"](#).

DATA MONITOR	
MONITOR	NO DTC
4WD LOCK IND	ON

SDIA2064E

5. CHECK AWD CONTROL UNIT

Check AWD control unit input/output signal. Refer to [TF-23, "AWD Control Unit Input/Output Signal Reference Values"](#).

OK or NG

- OK >> GO TO 6.
NG >> Check AWD control unit pin terminals for damage or loose connection with harness connector. If any items are damaged, repair or replace damaged parts.

6. SYMPTOM CHECK

Check again.

OK or NG

- OK >> **INSPECTION END**
NG >> Replace unified meter control unit assembly. Refer to [DI-26, "Disassembly and Assembly of Combination Meter"](#).

TROUBLE DIAGNOSIS FOR SYMPTOMS

Heavy Tight-corner Braking Symptom Occurs When The Vehicle Is Driven in AUTO Mode and The Steering Wheel Is Turned Fully to Either Side after The Engine Is Started

ADS000VU

NOTE:

- Light tight-corner braking symptom may occur depending on driving conditions in AUTO mode. This is not malfunction.
- Heavy tight-corner braking symptom occurs when vehicle is driven in the following conditions: LOCK mode, steering wheel is turned fully to either sides, and accelerator pedal was depressed.

DIAGNOSTIC PROCEDURE

1. CHECK SYSTEM FOR CAN COMMUNICATION LINE

Perform self-diagnosis. Refer to [TF-25, "SELF-DIAG RESULT MODE"](#) .

Is the "CAN COMM CIRCUIT [U1000]" displayed?

- YES >> Perform trouble diagnosis for CAN communication line. Refer to [TF-36, "CAN Communication Line"](#) .
- NO >> GO TO 2.

2. CHECK SYSTEM FOR AWD LOCK SWITCH

Perform trouble diagnosis for AWD lock switch system. Refer to [TF-34, "AWD Lock Switch"](#) .

OK or NG

- OK >> GO TO 3.
- NG >> Repair or replace damaged parts.

3. CHECK ACCELERATOR PEDAL POSITION SIGNAL CIRCUIT

Perform self-diagnosis for ECM. Refer to [EC-47, "Emission-Related Diagnostic Information"](#) .

Is any malfunction detected by self-diagnosis?

- YES >> Check the malfunctioning system.
- NO >> GO TO 4.

4. CHECK SYSTEM FOR AWD SOLENOID

Perform trouble diagnosis for AWD solenoid system. Refer to [TF-30, "AWD Solenoid"](#) .

OK or NG

- OK >> GO TO 5.
- NG >> Repair or replace damaged parts.

5. CHECK ELECTRIC CONTROLLED COUPLING

1. Turn ignition switch "OFF".
2. Set the selector lever to "N" (neutral) position and disengage the parking brake.
3. Lift up the vehicle.
4. Rotate the propeller shaft by hand.
5. Hold rear wheel of right and left lightly.

Does rear wheel rotate?

- YES >> Replace electric controlled coupling for mechanical malfunction (clutch sticking etc.). Refer to [RFD-16, "Disassembly and Assembly"](#) .
- NO >> GO TO 6.

TROUBLE DIAGNOSIS FOR SYMPTOMS

6. SYMPTOM CHECK

Check again.

OK or NG

- OK >> **INSPECTION END**
- NG >> GO TO 7.

7. CHECK AWD CONTROL UNIT

Check AWD control unit input/output signals. Refer to [TF-23, "AWD Control Unit Input/Output Signal Reference Values"](#) .

OK or NG

- OK >> **INSPECTION END**
- NG >> Check AWD control unit pin terminals for damage or loose connection with harness connector. If any items are damaged, repair or replace damaged parts.

Vehicle Does Not Enter AWD Mode Even Though AWD Warning Lamp Turned to OFF

ADS000VV

CAUTION:

Make sure that parking brake is securely released if the symptom has occurred at vehicle speed of 10 km/h (6 MPH) or more.

DIAGNOSTIC PROCEDURE

1. CHECK PARKING BRAKE SWITCH SIGNAL

④ With CONSULT-II

1. Turn ignition switch "ON".
2. Select "DATA MONITOR" mode for "ALL MODE AWD/4WD" with CONSULT-II.
3. Operate parking brake and read out monitor "P BRAKE SW".

Monitor item	Condition	Display value
P BRAKE SW	Parking brake operated	ON
	Parking brake not operated	OFF

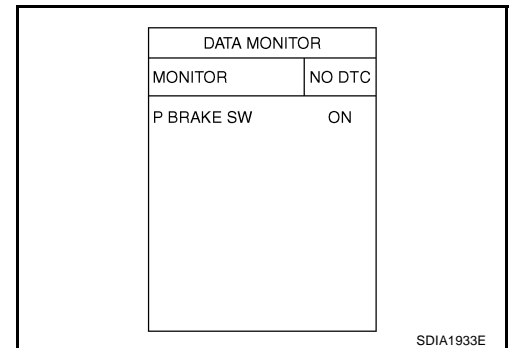

OK or NG

- OK >> GO TO 2.
- NG >> Check the following. If any items are damaged, repair or replace damaged parts.
 - Parking brake switch
 - Brake warning lamp circuit. Refer to [DI-43, "Wiring Diagram — WARN —"](#) .

2. CHECK AWD SOLENOID

Check AWD solenoid. Refer to [TF-32, "COMPONENT INSPECTION"](#) .

OK or NG

- OK >> GO TO 3.
- NG >> Replace electric controlled coupling for malfunction of AWD solenoid. Refer to [RFD-16, "Disassembly and Assembly"](#) .

TROUBLE DIAGNOSIS FOR SYMPTOMS

3. CHECK AWD CONTROL UNIT

Check AWD control unit input/output signal. Refer to [TF-23, "AWD Control Unit Input/Output Signal Reference Values"](#).

OK or NG

OK >> GO TO 4.

NG >> Check AWD control unit pin terminals for damage or loose connection with harness connector. If any items are damaged, repair or replace damaged parts.

4. SYMPTOM CHECK

Check again.

OK or NG

OK >> **INSPECTION END**

NG >> Replace electric controlled coupling for mechanical malfunction (mechanical engagement of clutch is not possible.). Refer to [RFD-16, "Disassembly and Assembly"](#).

While Driving, AWD Warning Lamp Flashes Rapidly (When Flashing in Approx. 1 Minute and Then Turning OFF)

ADS000VW

NOTE:

Rapid flashing: 2 times/second

This symptom protects drivetrain parts when a heavy load is applied to the electric controlled coupling and multiple disc clutch temperature increases. It is not a malfunction.

When this symptom occurs, stop vehicle and allow it to idle for some times. Flashing will stop and system will be restored.

While Driving, AWD Warning Lamp Flashes Slowly (When Continuing to Flash until Turning Ignition Switch OFF)

ADS000VX

NOTE:

Slow flashing: 1 time/2 seconds

DIAGNOSTIC PROCEDURE

1. CHECK TIRE

Check the following.

- Tire pressure
- Wear condition
- Front and rear tire size (There is no difference between front and rear tires.)

OK or NG

OK >> GO TO 2.

NG >> Drive at vehicle speed of 20 km/h (12 MPH) or more for 5 seconds or more after repairing or replacing damaged parts. (Initialize improper size tire information.)

TROUBLE DIAGNOSIS FOR SYMPTOMS

2. CHECK INPUT SIGNAL OF TIRE DIAMETER

④ With CONSULT-II

1. Start engine.
2. Drive at 20 km/h (12 MPH) or more for approx. 200 seconds.
3. Select "DATA MONITOR" mode for "ALL MODE AWD/4WD" with CONSULT-II.
4. Check monitor "DIS-TIRE MONI".

Display of "DIS-TIRE MONI"

"0-4mm">>**INSPECTION END**

Except for "0-4mm">>GO TO 3.

DATA MONITOR	
MONITOR	NO DTC
DIS-TIRE MONI	0-4mm

SDIA1900E

3. CHECK AWD CONTROL UNIT

Check AWD control unit input/output signals. Refer to [TF-23, "AWD Control Unit Input/Output Signal Reference Values"](#).

OK or NG

OK >> GO TO 4.

NG >> Check AWD control unit pin terminals for damage or loose connection with harness connector. If any item is damaged, repair or replace damaged parts.

4. SYMPTOM CHECK

Check again.

OK or NG

OK >> **INSPECTION END**

NG >> Replace AWD control unit.

AWD CONTROL UNIT

AWD CONTROL UNIT

PFP:41650

Removal and Installation

ADS000VY

REMOVAL

1. Remove instrument driver lower panel. Refer to [IP-11, "Removal and Installation"](#) .
2. Remove fuse block (J/B).
3. Disconnect AWD control unit connector.
4. Remove AWD control unit.

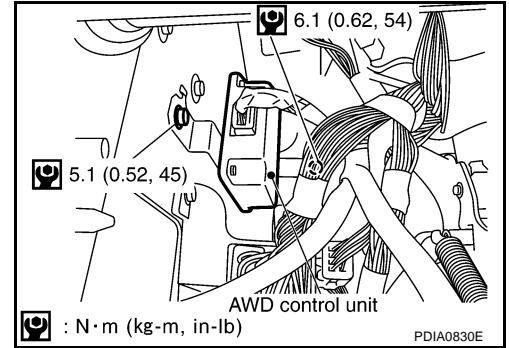

INSTALLATION

Install in the reverse order of removal.

A
B
C
TF
E
F
G
H
I
J
K
L
M

SIDE OIL SEAL

PFP:33142

SIDE OIL SEAL

Removal and Installation

ADS000UC

NOTE:

Transaxle side oil seal is attached to transaxle assembly. Replace it when transfer assembly is removed from vehicle.

REMOVAL

1. Remove RH drive shaft. Refer to [FAX-7, "FRONT DRIVE SHAFT"](#) .
2. Remove side shaft. Refer to [FAX-7, "FRONT DRIVE SHAFT"](#) .

CAUTION:

Be careful not to damage gear ring oil seal inside of transfer.

3. Remove oil seal with a flat-bladed screwdriver.

CAUTION:

Be careful not to damage adapter case.

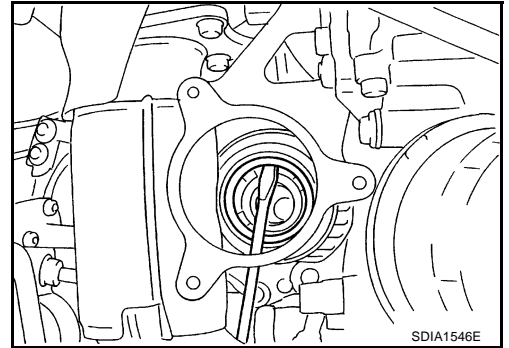

INSTALLATION

1. Apply multi-purpose grease to oil seal lips. As shown in the figure, install oil seal so that it becomes flush with the case end surface, using the drift.

Tool number : KV38101700 (—)

CAUTION:

- Do not reuse oil seal.
- When installing, do not incline oil seal.

2. Install side shaft. Refer to [FAX-7, "FRONT DRIVE SHAFT"](#) .

CAUTION:

Be careful not to damage gear ring oil seal inside of transfer.

3. Install RH drive shaft. Refer to [FAX-7, "FRONT DRIVE SHAFT"](#) .
4. Check oil level. Refer to [TF-10, "Inspection"](#) .

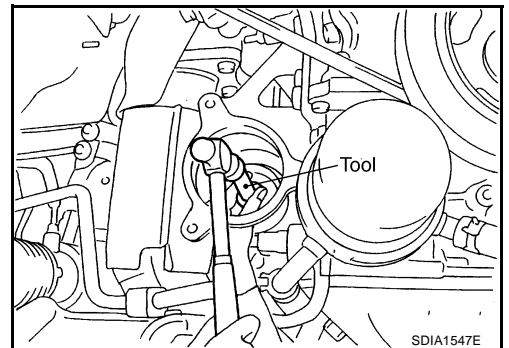

AIR BREATHER HOSE

AIR BREATHER HOSE

PFP:31098

Components

ADS000WU

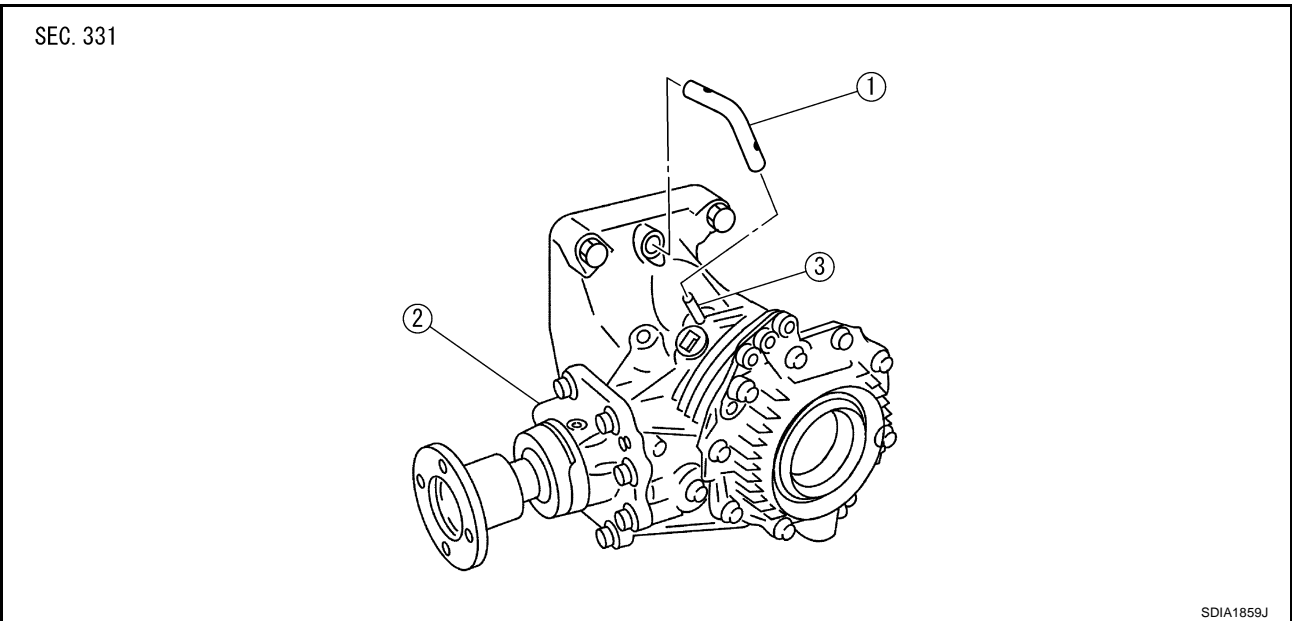

1. Air breather hose

2. Transfer assembly

3. Breather tube

Removal and Installation

ADS000WV

Note the following, when removal and installation.

CAUTION:

Make sure there are no pinched or restricted areas on the air breather hose caused by bending or winding when installing it.

- Be sure to insert air breather hose into breather tube (metal connector) until hose end reaches the tube's base.

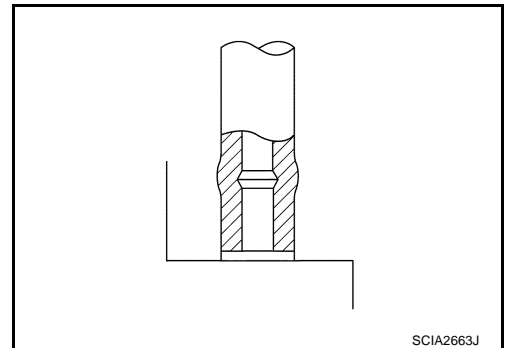

- Be sure to insert the hose till the paint mark.

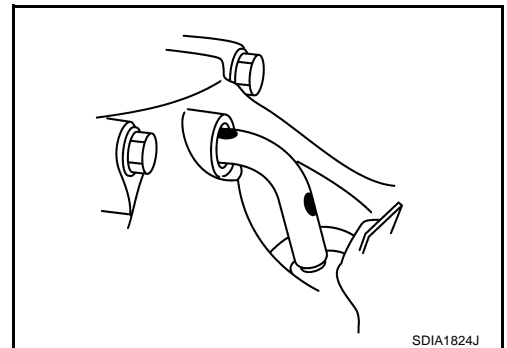

A
B
C
TF
E
F
G
H
I
J
K
L
M

TRANSFER ASSEMBLY

PF3:33100

ADS000UE

TRANSFER ASSEMBLY

Removal and Installation COMPONENTS

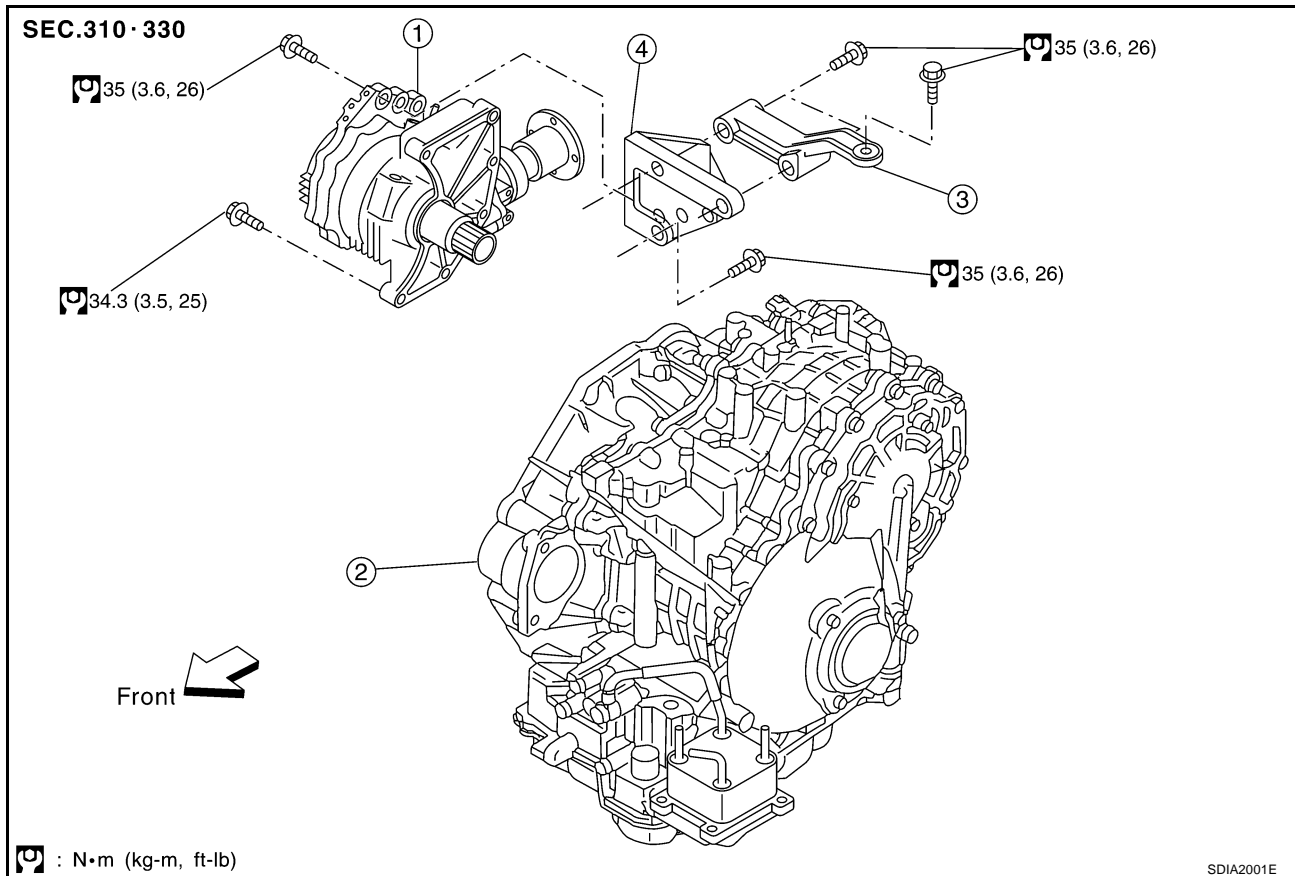

1. Transfer assembly

2. Transaxle assembly

3. Rear gusset

4. Transfer gusset

REMOVAL

NOTE:

The transfer assembly itself cannot be removed from vehicle. Remove transfer assembly together with engine assembly and transaxle assembly from vehicle.

1. Remove transfer assembly both with engine assembly and transaxle assembly from vehicle. Refer to [EM-107, "ENGINE ASSEMBLY"](#).
2. Remove RH drive shaft. Refer to [FAX-8, "Removal and Installation \(Right Side\)"](#).
3. Remove side shaft. Refer to [FAX-8, "Removal and Installation \(Right Side\)"](#).

CAUTION:

Be careful not to damage oil seal.

4. Remove rear gusset and transfer gusset.
5. Remove bolts fixing transaxle assembly and transfer assembly.
6. Remove the transfer assembly from transaxle.

CAUTION:

After removing transfer assembly from transaxle, be sure to replace differential side oil seal of the transaxle with new one. Refer to [CVT-226, "DIFFERENTIAL SIDE OIL SEAL"](#).

INSTALLATION

Note the following, and install in the reverse order of removal.

TRANSFER ASSEMBLY

- When installing the transfer to the transaxle, install the mounting bolts following the standard below.

Bolt No.	1	2
Quantity	4	2
Bolt length "ℓ" mm (in)	65 (2.56)	40 (1.57)
Tightening torque N·m (kg-m, ft-lb)	34.3 (3.5, 25)	

CAUTION:

When installing transfer to transaxle, be careful not to damage oil seal of transaxle.

- After the installation, check the oil level and oil leakage. Refer to [TF-10, "Inspection"](#).

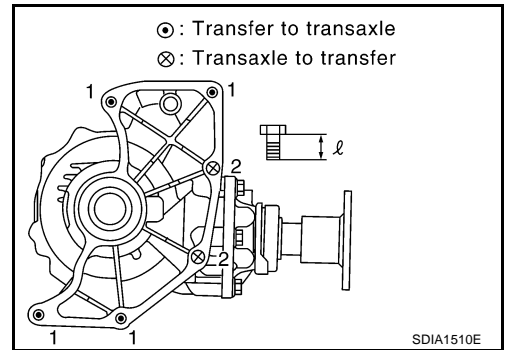

A
B
C

TF

E
F
G
H
I
J
K
L
M

TRANSFER ASSEMBLY

ADS000WW

Disassembly and Assembly COMPONENTS

SEC.330·331·332

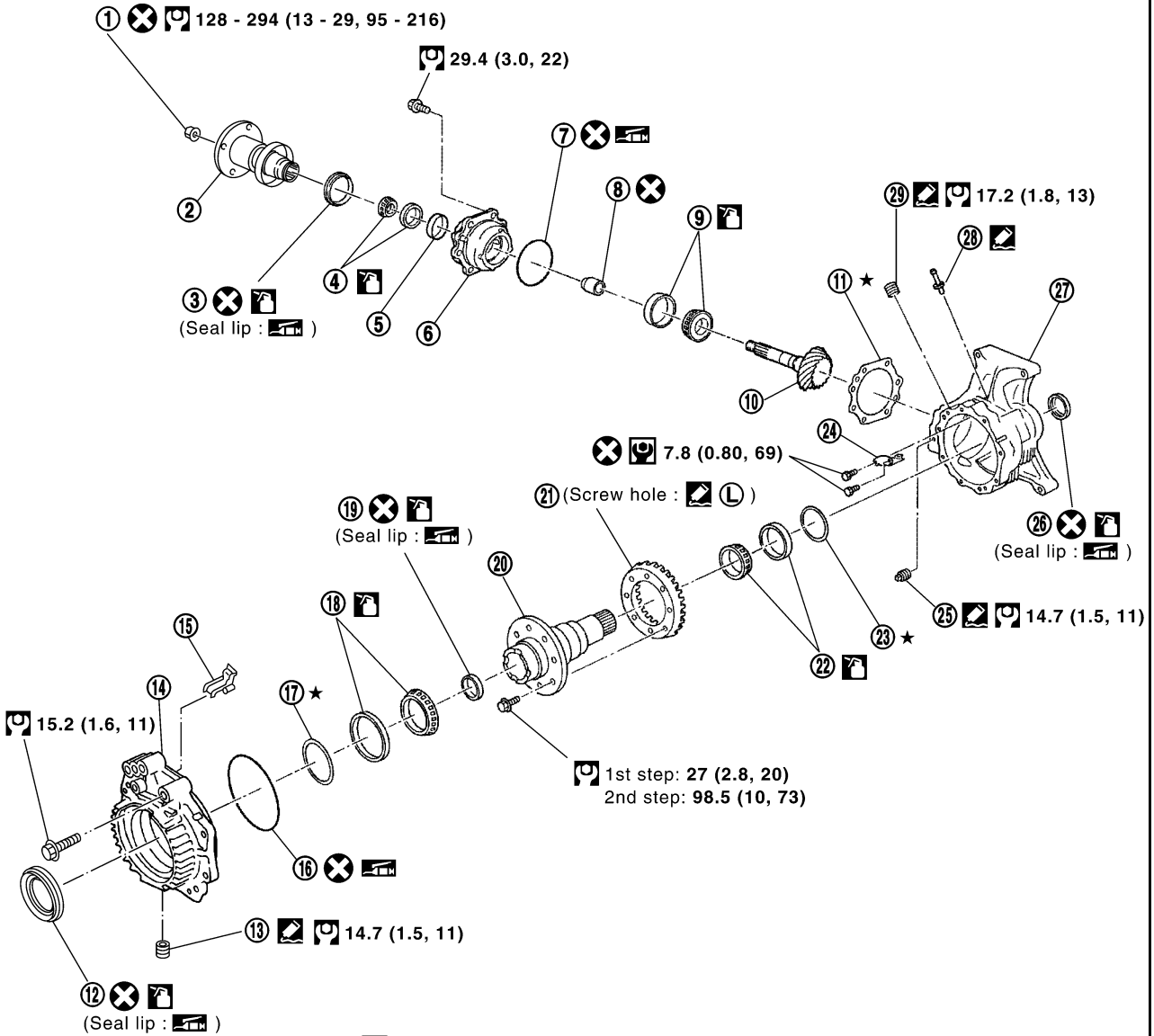

: N·m (kg-m, in-lb)

: N·m (kg-m, ft-lb)

: Lubricate with new gear oil.

★ : Select with proper thickness.

: Apply Genuine Silicone RTV or equivalent. Refer to GI section.

: Apply Genuine High Strength Thread Locking Sealant or equivalent. Refer to GI section.

: Apply multi-purpose grease.

: Always replace after every disassembly.

PDIA0735E

- | | | |
|--|---|---|
| 1. Pinion lock nut | 2. Companion flange | 3. Pinion sleeve oil seal |
| 4. Pinion rear bearing | 5. Dust cover | 6. Pinion sleeve |
| 7. O-ring | 8. Collapsible spacer | 9. Pinion front bearing |
| 10. Drive pinion | 11. Pinion sleeve shim | 12. Adapter case oil seal |
| 13. Drain plug | 14. Adapter case | 15. Oil gutter |
| 16. O-ring | 17. Gear ring bearing adjusting shim (Adapter case side) | 18. Gear ring bearing (Adapter case side) |
| 19. Gear ring oil seal | 20. Gear ring | 21. Drive gear |
| 22. Gear ring bearing (Transfer case side) | 23. Gear ring bearing adjusting shim (Transfer case side) | 24. Oil defense |
| 25. Filler plug | 26. Transfer case oil seal | 27. Transfer case |
| 28. Breather tube | | |

TRANSFER ASSEMBLY

ASSEMBLY INSPECTION

Backlash

1. Install a bolt to the companion flange.
2. Fit a dial indicator onto the bolt.
3. Measure the circumference backlash of the companion flange, and make sure it satisfies the standard below.

Backlash : 0.13 - 0.19 mm (0.0051 - 0.0075 in)

- If measured value is out of the specification, disassemble it to check and adjust each part.

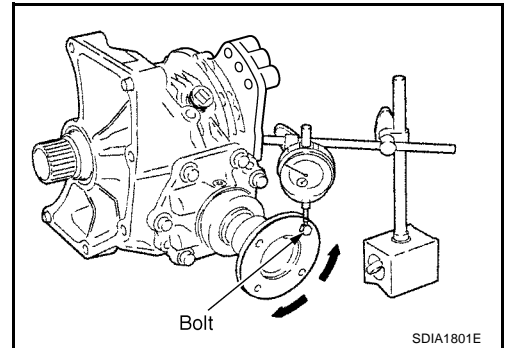

Tooth Contact

1. Remove the pinion sleeve assembly. Refer to [TF-59, "Pinion Sleeve Assembly"](#).
2. Apply red lead to the drive gear.

CAUTION:

Apply red lead to both the faces of 3 to 4 gears at 4 locations evenly spaced on the drive gear.

3. Install the pinion sleeve shims and pinion sleeve assembly. Refer to [TF-69, "Pinion Sleeve Assembly"](#).
4. Remove the plug on the upper side of the transfer case. When installing plug, apply sealant on screw part, and tighten it at the specified torque. Refer to [TF-54, "COMPONENTS"](#).
 - **Use Genuine Silicone RTV or equivalent. Refer to [GI-47, "Recommended Chemical Products and Sealants"](#).**
5. Rotate the companion flange back and forth several times, and check the drive pinion gear to drive gear tooth contact by viewing from the plug hole.

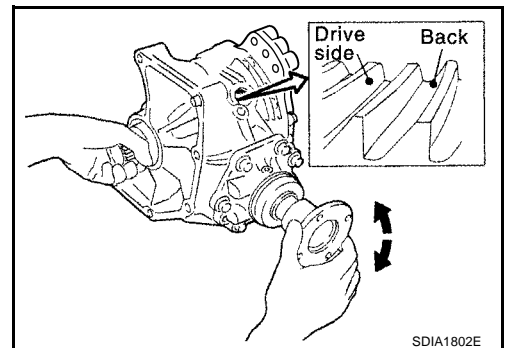
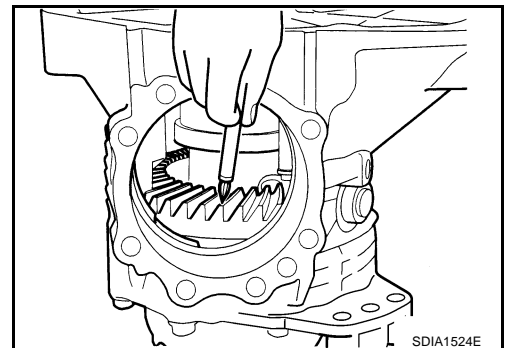

A
B
C
TF
E
F
G
H
I
J
K
L
M

TRANSFER ASSEMBLY

Pinion sleeve shim selection value mm (in)		Tooth contact condition		Need for adjustment
		Drive side	Back	
↑ Thicker	+0.12 (+0.0047)	Heel side 	Toe side 	Yes
	+0.09 (+0.0035)			
	+0.06 (+0.0024)			
	+0.03 (+0.0012)			
↓ Thinner	0 (0.0)			No
	-0.03 (-0.0012)			
	-0.06 (-0.0024)			
	-0.09 (-0.0035)			
	-0.12 (-0.0047)			Yes

SDIA0520E

6. If tooth contact is poorly adjusted, adjust pinion height (dimension X) in the following manner.

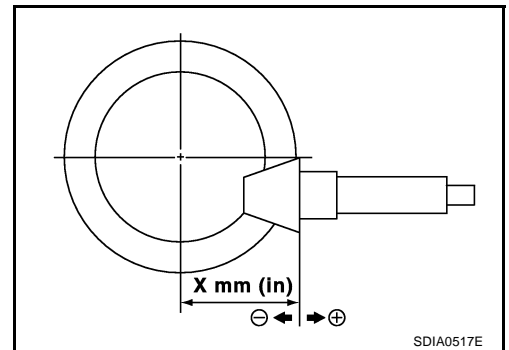

TRANSFER ASSEMBLY

- If the tooth contact is near the face (face contact), or near the heel (heel contact), thin the pinion sleeve shims to move the drive pinion closer to the drive gear.
Refer to [TF-72, "Pinion Sleeve Shim"](#) .

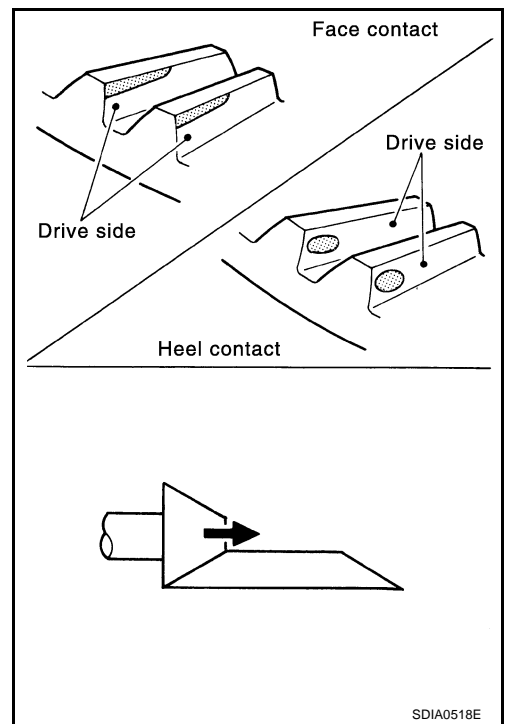

- If the tooth contact is near the flank (flank contact), or near the toe (toe contact), thicken the pinion sleeve shims to move the drive pinion farther from the drive gear.
Refer to [TF-72, "Pinion Sleeve Shim"](#) .

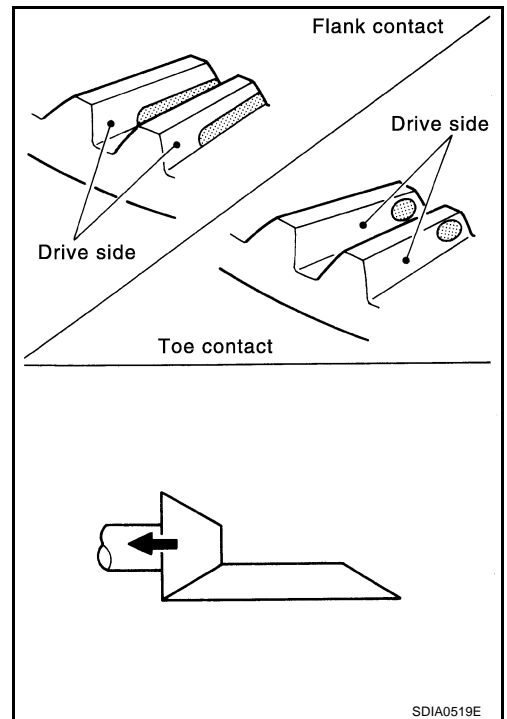

Pinion Bearing Preload Torque

1. Remove the pinion sleeve assembly. Refer to [TF-59, "Pinion Sleeve Assembly"](#) .
2. Rotate the companion flange back and forth 2 to 3 times. Check for unusual noise, rotation malfunction, and other malfunctions.
3. Rotate the companion flange at least 20 times to check for smooth operation of the bearing.

TRANSFER ASSEMBLY

- Using a preload gauge, measure the preload torque of the pinion bearing.

Tool number : ST3127S000 (J-25765-A)

Preload torque

: 0.10 - 0.39 N·m (0.01 - 0.04 kg·m, 1 - 3 in·lb)

CAUTION:

Every rotational part shall rotate smoothly with the specified gear oil.

- If measured value is out of the specification, disassemble the pinion sleeve assembly to check and adjust each part.

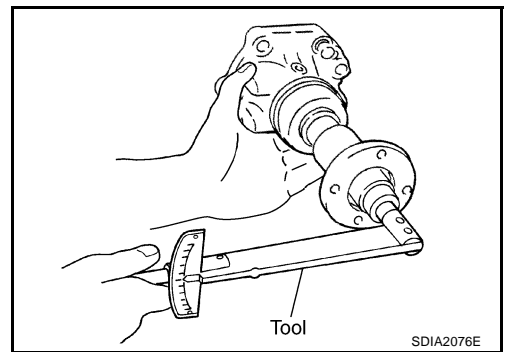

Total Preload Torque

- Measure pinion bearing preload torque (P1). Refer to [TF-57, "Pinion Bearing Preload Torque"](#).

Pinion bearing preload torque (P1)

: 0.10 - 0.39 N·m (0.01 - 0.04 kg·m, 1 - 3 in·lb)

- Install the pinion sleeve shims and pinion sleeve assembly.
- Rotate the companion flange at least 20 times to check for smooth operation of the bearing.
- Using the preload gauge, measure the total preload torque.

Tool number : ST3127S000 (J-25765-A)

Total preload torque

With all oil seals

: $P_1 + 0.16 - 0.22$ N·m (0.016 - 0.023 kg·m, 1.4 - 1.9 in·lb)

Without transfer case oil seal and adapter case oil seal

: $P_1 + 0.06 - 0.12$ N·m (0.006 - 0.013 kg·m, 0.6 - 1.1 in·lb)

- If measured value is out of the specification, disassemble it to check and adjust each part. If measuring the total preload torque after the disassembly, measure it with the transfer case oil seals and gear ring oil seals removed, then install the oil seals.

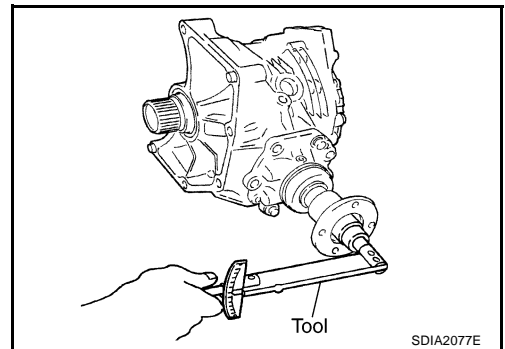

Companion Flange Runout

- Fit a dial indicator onto the companion flange face (inner side of the propeller shaft mounting bolt holes).
- Rotate the companion flange to check for runout.

Runout limit : 0.1 mm (0.004 in)

- Fit a test indicator to the inner side of the companion flange (socket diameter).
- Rotate the companion flange to check for runout.

Runout limit : 0.1 mm (0.004 in)

- If the runout value is outside the repair limit, follow the procedure below to adjust.
 - While changing the phase between companion flange and drive pinion gear by 90° at a time, check runout and determine which phase angle minimizes the runout.
 - If the runout value is still outside of the limit after the phase has been changed, replace the companion flange.
 - If the runout is out of the specification after replacement of companion flange, adjust the assembly status of the pinion bearings and drive pinion gear, or replace the pinion bearings.

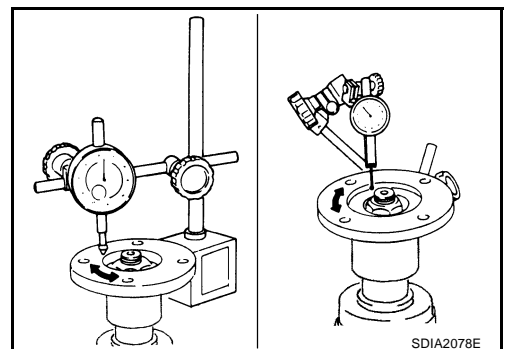

TRANSFER ASSEMBLY

DISASSEMBLY

Pinion Sleeve Assembly

1. Remove pinion sleeve mounting bolts.

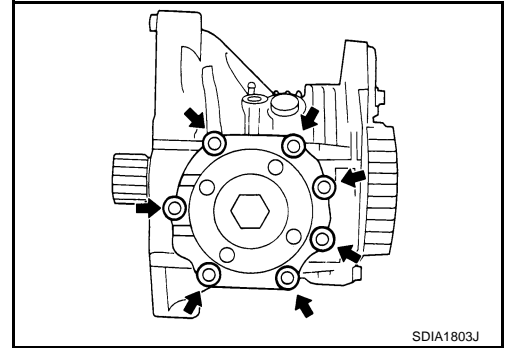

2. Using a plastic hammer, tap companion flange to remove pinion sleeve assembly.

3. Remove the pinion sleeve shim.

4. Remove the pinion lock nut.

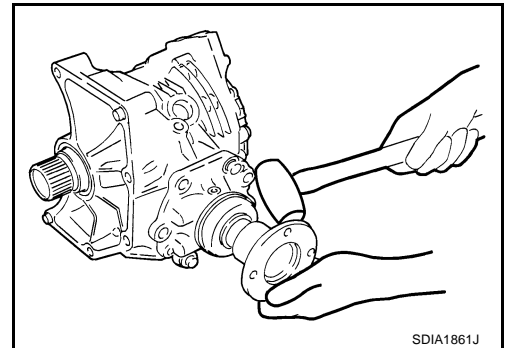

5. Using the drift, remove drive pinion assembly from pinion sleeve with a press.

Tool number : ST33220000 (J-25804-01)

6. Remove companion flange.

7. Remove the O-ring from pinion sleeve.

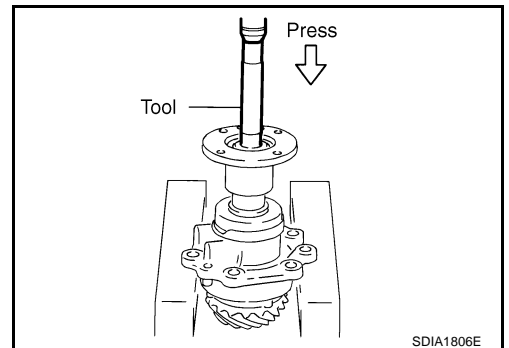

8. Using a flat-bladed screwdriver, remove the pinion sleeve oil seal.

CAUTION:
Be careful not to damage the pinion sleeve.

9. Remove the pinion rear bearing inner race.

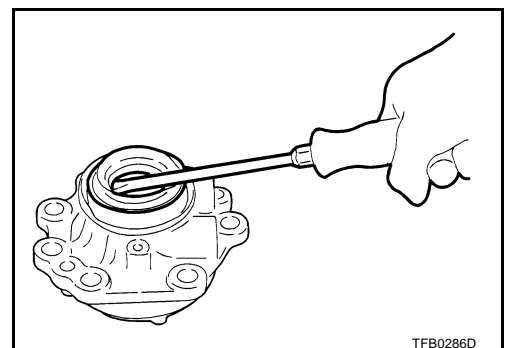

A
B
C
TF

E
F
G
H

I
J
K
L

M

TRANSFER ASSEMBLY

10. Using the puller, remove the pinion rear bearing outer race.

Tool number : KV381054S0 (J-34286)

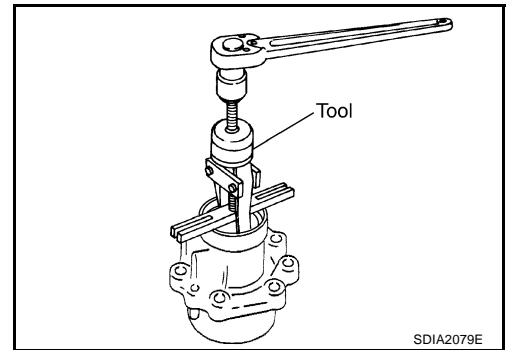

11. Using the puller, remove the pinion front bearing outer race.

Tool number : KV381054S0 (J-34286)

12. Remove dust cover.

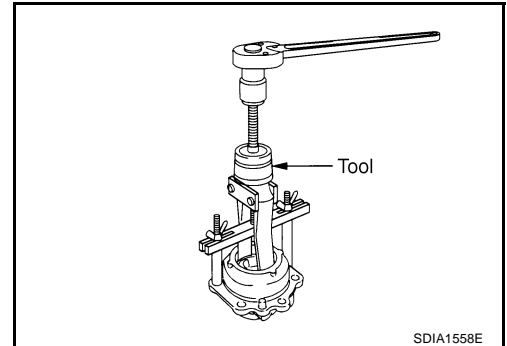

13. Remove the collapsible spacer from the drive pinion.

14. Using the replacer, press the pinion front bearing inner race out of the drive pinion.

Tool number : ST30031000 (J-22912-01)

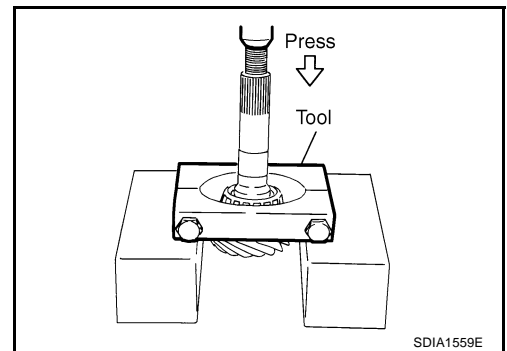

Adapter Case

1. Remove the adapter case mounting bolts.

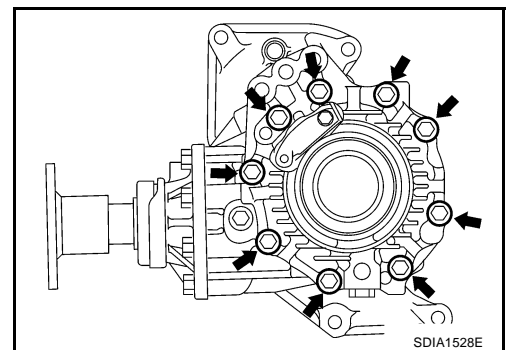

TRANSFER ASSEMBLY

- Using a plastic hammer, tap the adapter case to remove.
- Remove the O-ring.

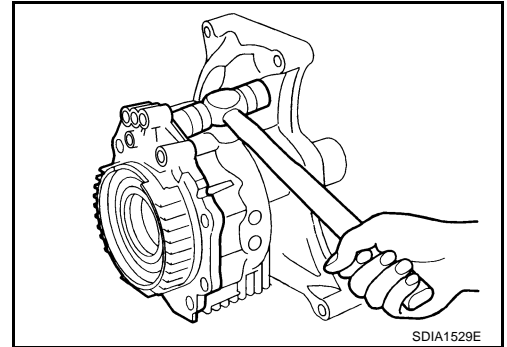

A
B
C

- Using a flat-bladed screwdriver, remove the adapter case oil seal.

CAUTION:

Be careful not to damage the adapter case.

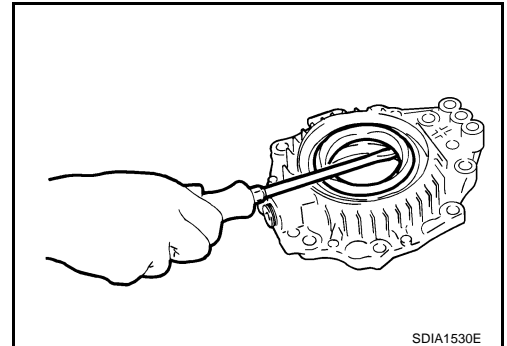

TF

E
F
G

- Using a brass rod, tap the gear ring bearing adjusting shim from the cutout on the adapter case to remove the gear ring bearing adjusting shim and gear ring bearing outer race.

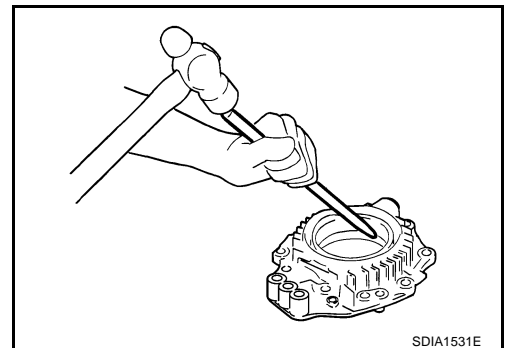

H
I
J

- Remove the oil gutter.
- Remove the drain plug.

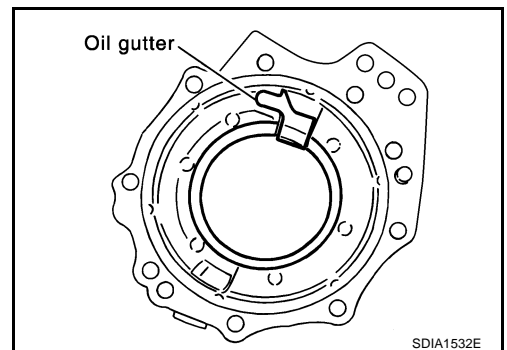

K
L
M

Drive Gear Assembly

- Remove the adapter case. Refer to [TF-60, "Adapter Case"](#).
- Remove the drive gear assembly from the transfer case.

TRANSFER ASSEMBLY

3. Using the drift and replacer, remove the gear ring bearing inner race (adapter case side) on the gear ring.

Tool number : ST33200000 (J-26082)

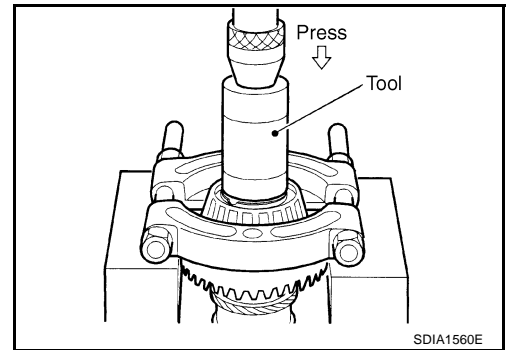

4. Using the drift and puller, remove the gear ring bearing inner race (transfer case side) on the gear ring.

Tool number : ST33061000 (J-8107-2)

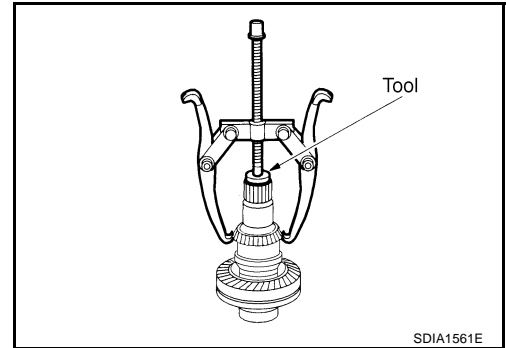

5. Remove the drive gear mounting bolts.

6. Using a plastic hammer, tap the drive gear to remove the drive gear from the gear ring.

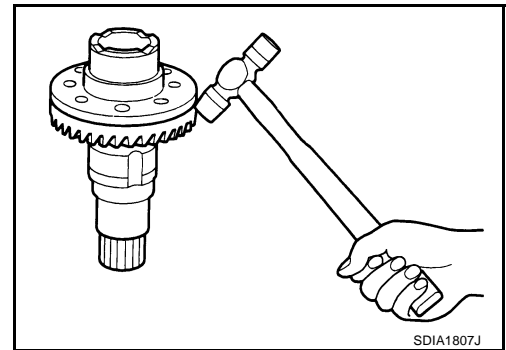

7. Using the puller, remove the gear ring oil seal from the gear ring.

Tool number : KV381054S0 (J-34286)

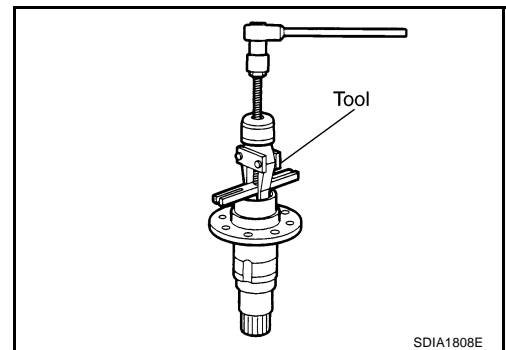

Transfer Case

1. Remove the pinion sleeve assembly. Refer to [TF-59, "Pinion Sleeve Assembly"](#) .
2. Remove the adapter case. Refer to [TF-60, "Adapter Case"](#) .
3. Remove the drive gear assembly from the transfer case. Refer to [TF-61, "Drive Gear Assembly"](#) .

TRANSFER ASSEMBLY

- Using a flat-bladed screwdriver, remove the transfer case oil seal.

CAUTION:

Be careful not to damage the transfer case.

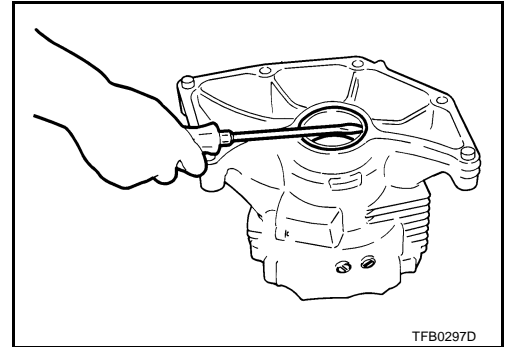

- Remove the oil defense.

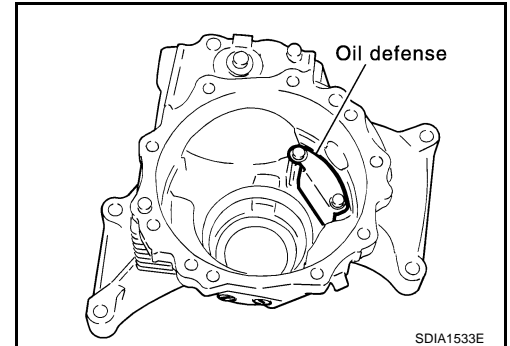

- Using a brass rod, tap the gear ring bearing adjusting shim evenly from the 2 cutouts on the transfer case to remove the gear ring bearing adjusting shim and gear ring bearing outer race.
- Remove the filler plug, plug and breather tube.

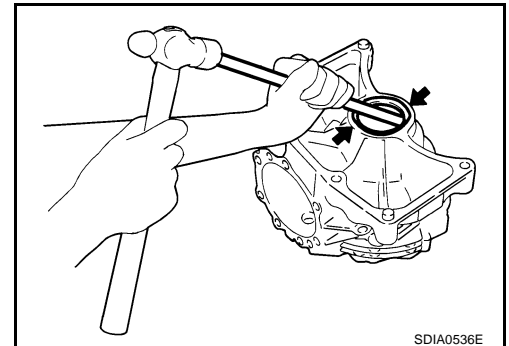

INSPECTION AFTER DISASSEMBLY

Gears

- Check the gear faces and shaft for wear, cracks, damage, and seizure.

CAUTION:

If a malfunction is detected on the drive gear or drive pinion, replace the drive gear and drive pinion as a set.

Bearings

- Check for seizure, peeling, wear, corrosion, sticking/abnormal noise/roughness in hand turning, and other damage.

CAUTION:

When replacing the bearing, always replace the inner race and outer race as a pair.

Washers and Shims

- Check for seizure, damage, and unusual wear.

Oil Seals

- Discard old oil seals, replace with new ones.
- If wear, deterioration of adherence (sealing force of lips), or damage is detected on the lips, replace them.

A
B
C
TF
E
F
G
H
I
J
K
L
M

TRANSFER ASSEMBLY

SELECTING ADJUSTING SHIMS

Measurement points

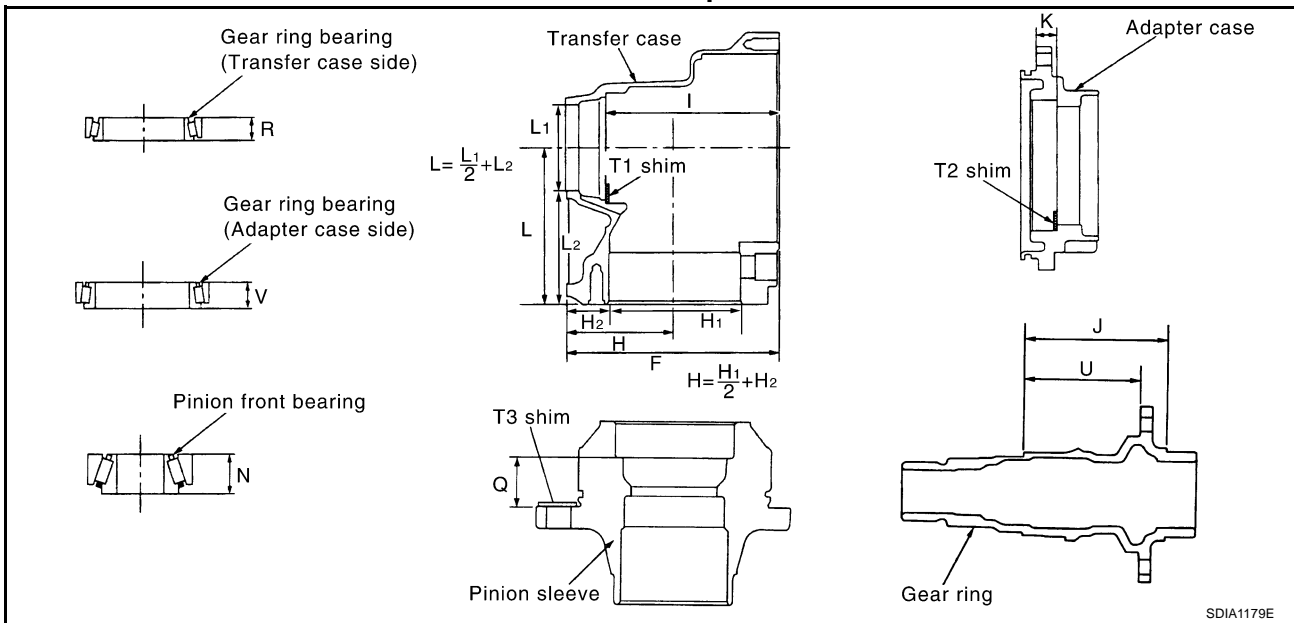

Gear Ring Bearing Adjusting Shim (Transfer Case Side)

1. Measure the points F, H, I, R and U shown in the measurement points.
2. Convert the values F, H, I, R and U according to the standards below.

F: Value obtained by subtracting 163.00 mm (6.42 in) from the reading [in increments of 0.01 mm (0.0004 in)].

H: Value obtained by subtracting 83.00 mm (3.27 in) from the reading [in increments of 0.01 mm (0.0004 in)].

I: Value obtained by subtracting 131.90 mm (5.19 in) from the reading [in increments of 0.01 mm (0.0004 in)].

R: Value obtained by subtracting 17.00 mm (0.67 in) from the reading [in increments of 0.01 mm (0.0004 in)].

U: Value obtained by subtracting 89.50 mm (3.524 in) from the reading [in increments of 0.01 mm (0.0004 in)].

3. Check dimension Z on the drive gear side face.

NOTE:

Dimension Z indicates the difference between the optimum engagement and the standard dimensions in increments of 0.01mm (0.0004 in) written on the drive gear side face.

4. Use the formula below to calculate gear ring bearing adjusting shim (transfer case side) thickness T1 .

$$T_1 = (I - F + H + Z - U - R) \times 0.01 \text{ mm (0.0004 in)} + 1.49 \text{ mm (0.0587 in)}$$

5. Select the gear ring bearing adjusting shim (transfer case side).

- For information on selecting an adjusting shim, refer to [TF-71, "Gear Ring Bearing Adjusting Shim \(Transfer Case Side\)"](#) .

CAUTION:

- Only one adjusting shim can be selected.
- If no adjusting shim with the calculated value is available, select the thicker and closest one.

Gear Ring Bearing Adjusting Shim (Adapter Case Side)

1. Measure the points F, H, J, K, U and V shown in the measurement points.
2. Convert the values F, H, J, K, U and V according to the standards below.

TRANSFER ASSEMBLY

F: Value obtained by subtracting 163.00 mm (6.42 in) from the reading [in increments of 0.01 mm (0.0004 in)].

H: Value obtained by subtracting 83.00 mm (3.27 in) from the reading [in increments of 0.01 mm (0.0004 in)].

J: Value obtained by subtracting 109.50 mm (4.31 in) from the reading [in increments of 0.01 mm (0.0004 in)].

K: Value obtained by subtracting 14.40 mm (0.5669 in) from the reading [in increments of 0.01 mm (0.0004 in)].

U: Value obtained by subtracting 89.50 mm (3.524 in) from the reading [in increments of 0.01 mm (0.0004 in)].

V: Value obtained by subtracting 17.00 mm (0.67 in) from the reading [in increments of 0.01 mm (0.0004 in)].

3. Check dimension Z on the drive gear side face.

NOTE:

Dimension Z indicates the difference between the optimum engagement and the standard dimensions in increments of 0.01mm (0.0004 in) written on the drive gear side face.

4. Use the formula below to calculate gear ring bearing adjusting shim (adapter case side) thickness T₂ .

$$T_2 = (K + F - H - Z + U - J - V) \times 0.01 \text{ mm (0.0004 in)} + 1.49 \text{ mm (0.0587 in)}$$

5. Select the gear ring bearing adjusting shim (adapter case side).

- For information on selecting an adjusting shim, refer to [TF-72, "Gear Ring Bearing Adjusting Shim \(Adapter Case Side\)"](#) .

CAUTION:

- Only one adjusting shim can be selected.
- If no adjusting shim with the calculated value is available, select the thicker and closest one.

Pinion Sleeve Shim

1. Measure the points L, N and Q shown in the measurement points.
2. Check the dimension S written on the gear end of the drive pinion.

NOTE:

The dimension S indicates the difference between the optimum engagement and the standard dimensions in increments of 0.01 mm (0.0004 in) written on the gear end of the drive pinion.

3. Use the formula below to calculate pinion sleeve shim thickness T₃ .

$$T_3 = [74.6 \text{ mm (2.937 in)} + S] + N + Q - L$$

4. Select the pinion sleeve shim.

- For information on selecting a pinion sleeve shim, refer to [TF-72, "Pinion Sleeve Shim"](#) .

CAUTION:

Only one pinion sleeve shim can be selected.

ASSEMBLY

Transfer Case

1. Select the gear ring bearing adjusting shim (transfer case side). Refer to [TF-64, "SELECTING ADJUSTING SHIMS"](#) .

TRANSFER ASSEMBLY

2. Using the drifts, install the selected gear ring bearing adjusting shim (transfer case side) and gear ring bearing outer race (transfer case side).

Tool number **A: ST30720000 (J-25405)**
 B: KV40101840 (—)

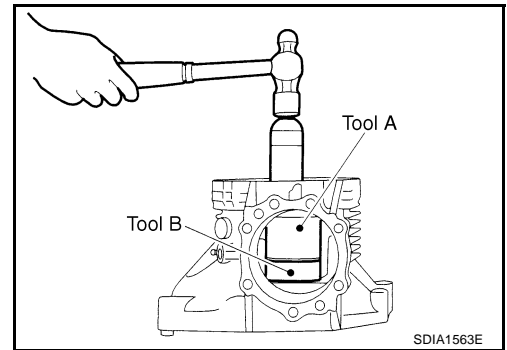

3. Install the oil defense, and tighten the mounting bolts to the specified torque. Refer to [TF-54, "COMPONENTS"](#) . The clearance between the oil defense and transfer case (dimension A) should be the following.

Clearance between oil defense and transfer case
Dimension A **: 1.0 - 3.5 mm (0.04 - 0.138 in)**

CAUTION:
Do not reuse the mounting bolts.

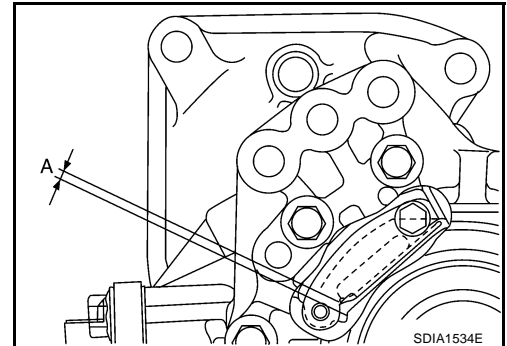

4. Using the drift, drive the transfer case oil seal until it becomes flush with the case end.

Tool number **: ST30720000 (J-25405)**

CAUTION:

- **When checking the total preload torque, measure it without the oil seal, then install the oil seal.**
 - **Do not reuse the oil seal.**
 - **Apply multi-purpose grease onto oil seal lips, and gear oil onto the circumference of the oil seal.**
5. Apply sealant to filler plug and plug before installing them to the transfer case. Refer to [TF-54, "COMPONENTS"](#) .
- **Use Genuine Silicone RTV or equivalent. Refer to [GI-47, "Recommended Chemical Products and Sealants"](#) .**
6. Apply sealant to breather tube and install it to the transfer case.
- **Use Genuine Silicone RTV or equivalent. Refer to [GI-47, "Recommended Chemical Products and Sealants"](#) .**
7. Install the drive gear assembly. Refer to [TF-67, "Drive Gear Assembly"](#) .
8. Install the adapter case. Refer to [TF-68, "Adapter Case"](#) .
9. Install the pinion sleeve assembly. Refer to [TF-69, "Pinion Sleeve Assembly"](#) .
10. Check backlash, preload torque, tooth contact, and companion flange runout. Refer to [TF-55, "ASSEMBLY INSPECTION"](#) .

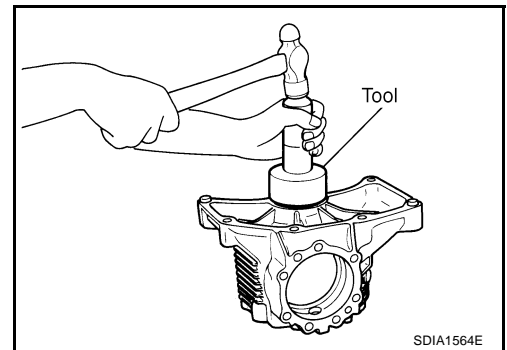

CAUTION:

Measure the total preload torque without the oil seal.

TRANSFER ASSEMBLY

Drive Gear Assembly

- Using the drift, drive the gear ring oil seal into the gear ring.

Tool number : ST33230000 (J-25805-01)

CAUTION:

- Do not reuse the oil seal.
- Apply multi-purpose grease onto oil seal lips, and gear oil onto the circumference of the oil seal.
- The oil seal back position after the installation shall be 56.5 mm (2.22 in) from the gear ring end.

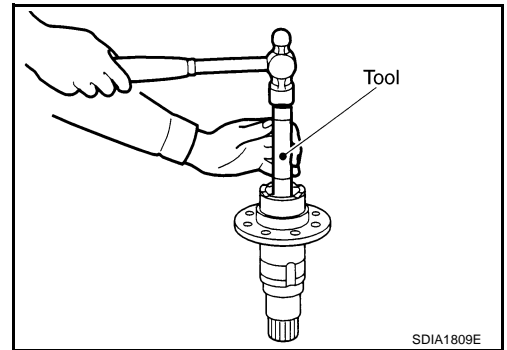

- Apply thread locking sealant into the thread hole for the drive gear.

- Use Genuine High Strength Thread Locking Sealant or equivalent. Refer to [GI-47, "Recommended Chemical Products and Sealants"](#).

- Completely clean and degrease the drive gear back face, thread holes, and drive gear mounting bolts.
- Apply thread locking sealant onto the first and second threads under the thread hole chamfering of the drive gear on 3 or more different points.

- Use Genuine High Strength Thread Locking Sealant or equivalent. Refer to [GI-47, "Recommended Chemical Products and Sealants"](#).

- Install the drive gear to gear ring, and apply anti-corrosive oil onto threads and seats on the mounting bolts, and then tighten to the specified torque. Refer to [TF-54, "COMPONENTS"](#).

CAUTION:

- Temporary installation before tightening the bolts through to the completion of the tightening should be within 90 seconds.
- If the thread locking sealant is applied aside, quickly wipe it off.

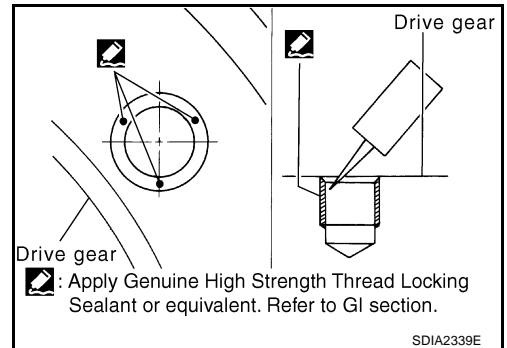

- Apply gear oil to gear ring bearing inner race (transfer case side). Using the drifts, install gear ring bearing inner race.

Tool number **A:** ST30720000 (J-25405)
 B: ST27863000 (—)
 C: KV40101630 (J-35870)

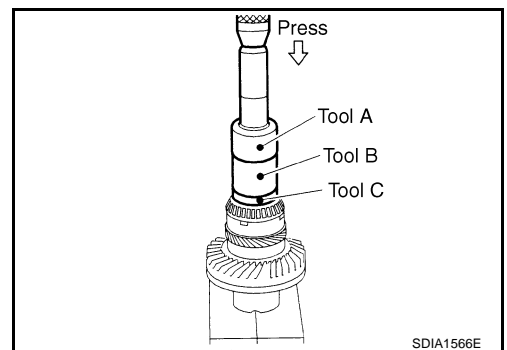

- Apply gear oil to gear ring bearing inner race (adapter case side). Using the drifts, install gear ring bearing inner race.

Tool number **A:** ST30720000 (J-25405)
 B: KV38102510 (—)

- Install the drive gear assembly to the transfer case.
- Install the adapter case.
- Check backlash, preload torque, tooth contact, and companion flange runout. Refer to [TF-55, "ASSEMBLY INSPECTION"](#).

CAUTION:

Measure the total preload torque without the oil seal.

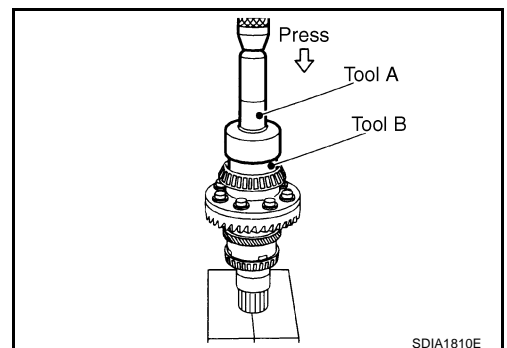

A
B
C
TF
E
F
G
H
I
J
K
L
M

TRANSFER ASSEMBLY

Adapter Case

1. Select the gear ring bearing adjusting shim (adapter case side). Refer to [TF-64, "SELECTING ADJUSTING SHIMS"](#) .
2. Install the oil gutter.
3. Using the drifts, install the selected gear ring bearing adjusting shim (adapter case side) and gear ring bearing outer race (adapter case side).

Tool number **A: ST30720000 (J-25405)**
 B: KV40105230 (—)

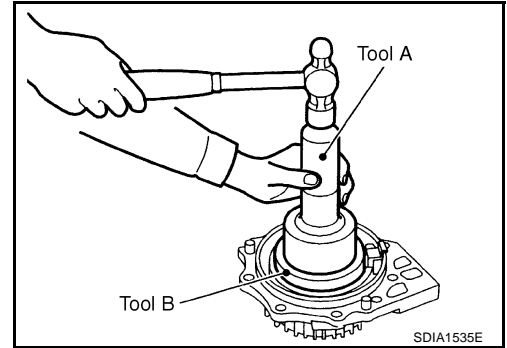

4. Using the drift, drive the adapter case oil seal until it becomes flush with the case end.

Tool number : **KV38101700 (—)**

CAUTION:

- When checking the total preload torque, measure it without the oil seal, then install the oil seal.
- Do not reuse the oil seal.
- Apply multi-purpose grease onto oil seal lips, and gear oil onto the circumference of the oil seal.

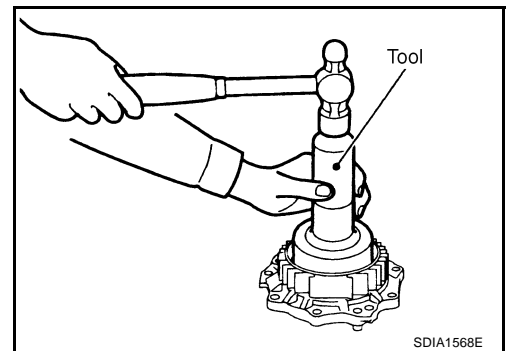

5. Apply sealant on drain plug and install it to the adapter case. Refer to [TF-54, "COMPONENTS"](#) .

- Use Genuine Silicone RTV or equivalent. Refer to [GI-47, "Recommended Chemical Products and Sealants"](#) .

6. Apply multi-purpose grease lightly and evenly onto an O-ring, and install it to the adapter case.

CAUTION:

Do not reuse the O-ring.

7. Install the adapter case to the transfer case, and apply anti-corrosive oil onto threads and seats on the mounting bolts. Tighten to the specified torque.

Bolt symbol	Bolt length "ℓ" mm (in)	Tightening torque N·m (kg·m, ft·lb)
A	45 (1.77)	15.2 (1.6, 11)
B	30 (1.18)	

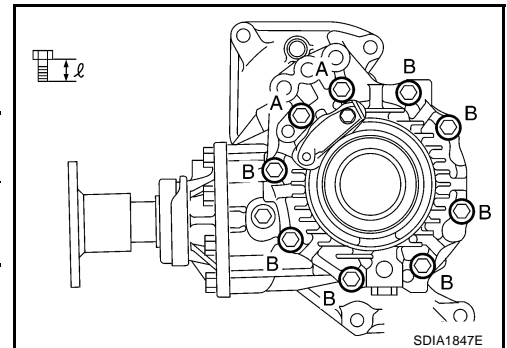

8. Check backlash, preload torque, tooth contact, and companion flange runout. Refer to [TF-55, "ASSEMBLY INSPECTION"](#) .

CAUTION:

Measure the total preload torque without the oil seal.

TRANSFER ASSEMBLY

Pinion Sleeve Assembly

1. Select the pinion sleeve shim. Refer to [TF-64, "SELECTING ADJUSTING SHIMS"](#).
2. Install dust cover.
3. Using the drift, install the pinion rear bearing outer race.

Tool number : KV38100300 (J-25523)

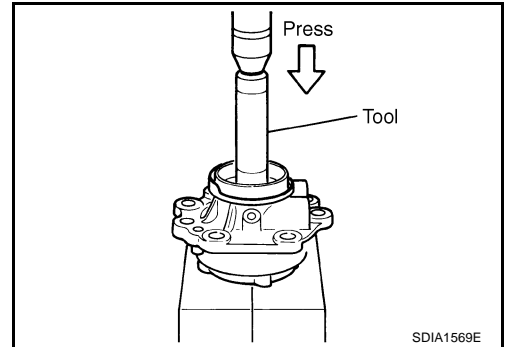

4. Using the drifts, install the pinion front bearing outer race.

Tool number A: ST33400001 (J-26082)
B: ST30901000 (J-26010-01)

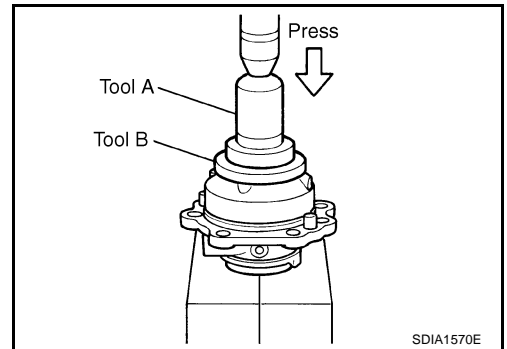

5. Apply gear oil to pinion front bearing inner race and mating position on the drive pinion. Using the drift, install pinion front bearing inner race to the drive pinion.

Tool number : ST30901000 (J-26010-01)

6. Install a collapsible spacer to the drive pinion.

CAUTION:
Do not reuse the collapsible spacer.

7. Apply gear oil to pinion rear bearing inner race and install it to the pinion sleeve.

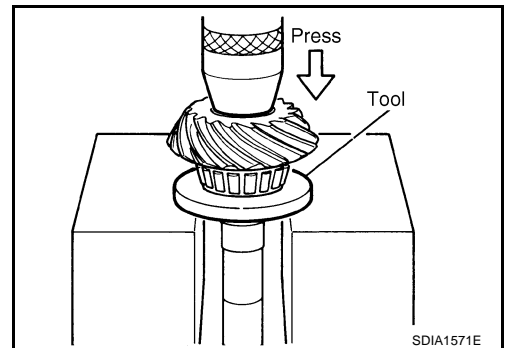

8. Using the drift, install pinion sleeve oil seal to the pinion sleeve.

Tool number : ST33400001 (J-26082)

CAUTION:

- Do not reuse the oil seal.
- Apply multi-purpose grease onto oil seal lips, and gear oil onto the circumference of the oil seal.

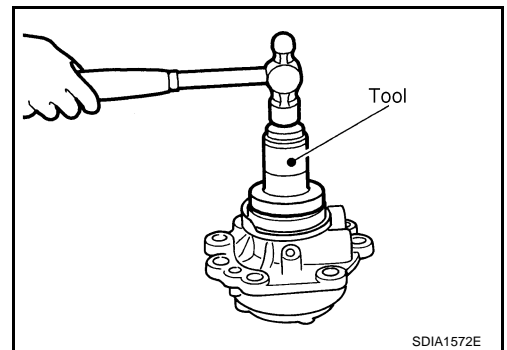

A
B
C
TF
E
F
G
H
I
J
K
L
M

TRANSFER ASSEMBLY

9. Using the drift and press in the companion flange.

Tool number : ST33200000 (J-26082)

10. Apply anti-corrosion oil onto threads and seat of the pinion lock nut and adjust the pinion lock nut tightening torque and pinion bearing preload torque (P'1), using a preload gauge.

Pinion lock nut tightening torque

 : 128 - 294 N-m (13 - 29 kg-m, 95 - 216 ft-lb)

Pinion bearing preload torque (P'1)

: 0.40 - 0.78 N-m (0.04 - 0.08 kg-m, 4 - 6 in-lb)

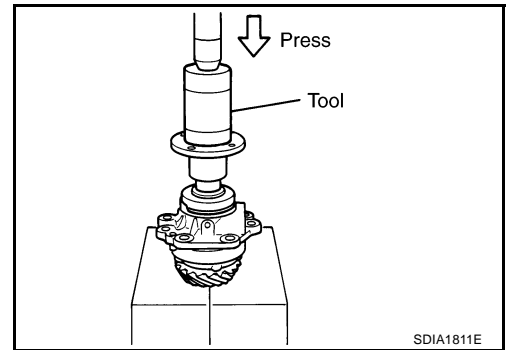

CAUTION:

- Do not reuse the pinion lock nut.
- Adjust the lower limit of the pinion lock nut tightening torque first.
- While confirming the preload torque, tighten pinion lock nut by 5° to 10°. Because preload will increase suddenly.
- If specified preload torque is exceeded, replace the collapsible spacer and tighten again. Never loosen the pinion lock nut for further preload torque adjustment.
- After the adjustment, rotate the companion flange back and forth 2 to 3 times to check for unusual noise, rotation malfunction, and other malfunctions.

11. Apply multi-purpose grease lightly and evenly onto an O-ring, and install it to the pinion sleeve.

CAUTION:

Do not reuse the old O-ring.

12. Assemble the selected pinion sleeve shim.

13. Install the pinion sleeve assembly, and apply anti-corrosive oil onto threads and seats on the mounting bolts. Tighten to the specified torque. Refer to [TF-54, "COMPONENTS"](#).

14. Check backlash, preload torque, tooth contact and companion flange runout. Refer to [TF-55, "ASSEMBLY INSPECTION"](#).

The total preload torque is as follows:

Total preload torque

With all oil seals installed : P'1 + 0.45 - 0.47 N-m (0.045 - 0.048 kg-m, 3.9 - 4.1 in-lb)

Without transfer case oil seal and adapter case oil seal

: P'1 + 0.35 - 0.37 N-m (0.035 - 0.038 kg-m, 3.1 - 3.2 in-lb)

SERVICE DATA AND SPECIFICATIONS (SDS)

SERVICE DATA AND SPECIFICATIONS (SDS)

PPF:00030

General Specifications

ADS000UW

Applied model		VQ35DE
Transfer model		TY20A
Oil capacity (Approx.)	ℓ (US pt, Imp pt)	0.31 (5/8, 1/2)
Gear ratio		0.404
Number of teeth	Drive pinion	17
	Drive gear	42

Inspection and Adjustment PRELOAD TORQUE BEFORE DISASSEMBLY

ADS000WX

Item		Specification [N·m (kg·m, in·lb)]
Pinion bearing (P1)		0.10 - 0.39 (0.01 - 0.04, 1 - 3)
Gear ring bearing to pinion bearing (Total preload)	With all oil seals	P1 + 0.16 - 0.22 (0.016 - 0.023, 1.4 - 1.9)
	Without transfer case oil seal and adapter case oil seal	P1 + 0.06 - 0.12 (0.006 - 0.013, 0.6 - 1.1)

PRELOAD TORQUE AFTER DISASSEMBLY AND REASSEMBLY

Item		Specification [N·m (kg·m, in·lb)]
Pinion bearing (P'1)		0.40 - 0.78 (0.04 - 0.08, 4 - 6)
Gear ring bearing to pinion bearing (Total preload)	With all oil seals	P'1 + 0.45 - 0.47 (0.045 - 0.048, 3.9 - 4.1)
	Without transfer case oil seal and adapter case oil seal	P'1 + 0.35 - 0.37 (0.035 - 0.038, 3.1 - 3.2)

BACKLASH

Unit: mm (in)

Item	Standard
Drive gear to drive pinion gear	0.13 - 0.19 (0.0051 - 0.0075)

COMPANION FLANGE RUNOUT

Unit: mm (in)

Item	Runout limit
Companion flange face	0.1 (0.004)
Inner side of the companion flange	0.1 (0.004)

SELECTIVE PARTS

Gear Ring Bearing Adjusting Shim (Transfer Case Side)

Unit: mm (in)

Thickness	Part number*	Thickness	Part number*	Thickness	Part number*
0.80 (0.0315)	33147 AD300	1.22 (0.0480)	33147 AD314	1.64 (0.0646)	33147 AD363
0.83 (0.0327)	33147 AD301	1.25 (0.0492)	33147 AD315	1.67 (0.0657)	33147 AD364
0.86 (0.0339)	33147 AD302	1.28 (0.0504)	33147 AD316	1.70 (0.0669)	33147 AD365
0.89 (0.0350)	33147 AD303	1.31 (0.0516)	33147 AD317	1.73 (0.0681)	33147 AD366
0.92 (0.0362)	33147 AD304	1.34 (0.0528)	33147 AD318	1.76 (0.0693)	33147 AD367
0.95 (0.0374)	33147 AD305	1.37 (0.0539)	33147 AD319	1.79 (0.0705)	33147 AD368
0.98 (0.0386)	33147 AD306	1.40 (0.0551)	33147 AD320	1.82 (0.0717)	33147 AD369
1.01 (0.0398)	33147 AD307	1.43 (0.0563)	33147 AD321	1.85 (0.0728)	33147 AD370
1.04 (0.0409)	33147 AD308	1.46 (0.0575)	33147 AD322	1.88 (0.0740)	33147 AD371
1.07 (0.0421)	33147 AD309	1.49 (0.0587)	33147 AD323	1.91 (0.0752)	33147 AD372
1.10 (0.0433)	33147 AD310	1.52 (0.0598)	33147 AD324	1.94 (0.0764)	33147 AD373
1.13 (0.0445)	33147 AD311	1.55 (0.0610)	33147 AD360	1.97 (0.0776)	33147 AD374
1.16 (0.0457)	33147 AD312	1.58 (0.0622)	33147 AD361	2.00 (0.0787)	33147 AD375
1.19 (0.0469)	33147 AD313	1.61 (0.0634)	33147 AD362	2.03 (0.0799)	33147 AD376

*: Always check with the Parts Department for the latest parts information.

SERVICE DATA AND SPECIFICATIONS (SDS)

Gear Ring Bearing Adjusting Shim (Adapter Case Side)

Unit: mm (in)

Thickness	Part number*	Thickness	Part number*	Thickness	Part number*
0.80 (0.0315)	33147 5V200	1.25 (0.0492)	33147 5V215	1.70 (0.0669)	33123 5V265
0.83 (0.0327)	33147 5V201	1.28 (0.0504)	33147 5V216	1.73 (0.0681)	33123 5V266
0.86 (0.0339)	33147 5V202	1.31 (0.0516)	33147 5V217	1.76 (0.0693)	33123 5V267
0.89 (0.0350)	33147 5V203	1.34 (0.0528)	33123 5V218	1.79 (0.0705)	33123 5V268
0.92 (0.0362)	33147 5V204	1.37 (0.0539)	33123 5V219	1.82 (0.0717)	33123 5V269
0.95 (0.0374)	33147 5V205	1.40 (0.0551)	33123 5V220	1.85 (0.0728)	33123 5V270
0.98 (0.0386)	33147 5V206	1.43 (0.0563)	33123 5V221	1.88 (0.0740)	33123 5V271
1.01 (0.0398)	33147 5V207	1.46 (0.0575)	33123 5V222	1.91 (0.0752)	33123 5V272
1.04 (0.0409)	33147 5V208	1.49 (0.0587)	33123 5V223	1.94 (0.0764)	33123 5V273
1.07 (0.0421)	33147 5V209	1.52 (0.0598)	33123 5V224	1.97 (0.0776)	33123 5V274
1.10 (0.0433)	33147 5V210	1.55 (0.0610)	33123 5V260	2.00 (0.0787)	33123 5V275
1.13 (0.0445)	33147 5V211	1.58 (0.0622)	33123 5V261	2.03 (0.0799)	33123 5V276
1.16 (0.0457)	33147 5V212	1.61 (0.0634)	33123 5V262	2.06 (0.0811)	33123 5V277
1.19 (0.0469)	33147 5V213	1.64 (0.0646)	33123 5V263	2.09 (0.0811)	33123 5V278
1.22 (0.0480)	33147 5V214	1.67 (0.0657)	33123 5V264		

*: Always check with the Parts Department for the latest parts information.

Pinion Sleeve Shim

Unit: mm (in)

Thickness	Part number*	Thickness	Part number*	Thickness	Part number*
0.77 (0.0303)	33155 5V214	0.98 (0.0386)	33155 5V206	1.19 (0.0469)	33155 5V213
0.80 (0.0315)	33155 5V200	1.01 (0.0398)	33155 5V207	1.22 (0.0480)	33155 5V215
0.83 (0.0327)	33155 5V201	1.04 (0.0409)	33155 5V208	1.25 (0.0492)	33155 5V216
0.86 (0.0339)	33155 5V202	1.07 (0.0421)	33155 5V209	1.28 (0.0504)	33155 5V217
0.89 (0.0350)	33155 5V203	1.10 (0.0433)	33155 5V210	1.31 (0.0516)	33155 5V218
0.92 (0.0362)	33155 5V204	1.13 (0.0445)	33155 5V211	1.34 (0.0528)	33155 5V219
0.95 (0.0374)	33155 5V205	1.16 (0.0457)	33155 5V212		

*: Always check with the Parts Department for the latest parts information.