

SECTION **SE**
SEAT

A
B
C
D
E
F
G
H
I
J
K
L
M

CONTENTS

PRECAUTIONS	3	KEYFOB INTERLOCK OPERATION	16
Precautions for Supplemental Restraint System (SRS) "AIR BAG" and "SEAT BELT PRE-TENSIONER"	3	Component Parts And Harness Connector Location	17
Service Notice	3	CAN Communication System Description	18
Precautions for Work	3	CAN Communication Unit	18
PREPARATION	4	Schematic	19
Special Service Tools	4	Wiring Diagram—AUT/DP—	21
Commercial Service Tools	4	Terminals and Reference Values for BCM	33
SQUEAK AND RATTLE TROUBLE DIAGNOSES	5	Terminals and Reference Values for Driver Seat Control Unit	33
Work Flow	5	Terminals and Reference Values for Automatic Driver Positioner Control Unit	36
CUSTOMER INTERVIEW	5	Work Flow	38
DUPLICATE THE NOISE AND TEST DRIVE	6	Preliminary Check	38
CHECK RELATED SERVICE BULLETINS	6	SETTING CHANGE FUNCTION	38
LOCATE THE NOISE AND IDENTIFY THE ROOT CAUSE	6	POWER SUPPLY AND GROUND CIRCUIT CHECK	39
REPAIR THE CAUSE	6	CONSULT-II Function (AUTO DRIVE POS.)	42
CONFIRM THE REPAIR	7	CONSULT-II INSPECTION PROCEDURE	42
Generic Squeak and Rattle Troubleshooting	7	SELF-DIAGNOSIS RESULTS	44
INSTRUMENT PANEL	7	DATA MONITOR	45
CENTER CONSOLE	7	ACTIVE TEST	46
DOORS	7	Check CAN Communication System Inspection ...	46
TRUNK	8	Symptom Chart	46
SUNROOF/HEADLINING	8	Sliding Motor Circuit Check	48
SEATS	8	Reclining Motor Circuit Check	49
UNDERHOOD	8	Front Lifting Motor Circuit Check	52
Diagnostic Worksheet	9	Rear Lifting Motor Circuit Check	53
CLIP AND FASTENER	11	Pedal Adjusting Motor Circuit Check	54
Clip and Fastener	11	Mirror Motor LH Circuit Check	56
AUTOMATIC DRIVE POSITIONER	12	Mirror Motor RH Circuit Check	58
System Description	12	Sliding Sensor Circuit Check	60
MANUAL OPERATION	12	Reclining Sensor Circuit Check	61
AUTOMATIC OPERATION	12	Front Lifting Sensor Circuit Check	62
FAIL- SAFE MODE	13	Rear Lifting Sensor Circuit Check	63
CANCEL OF FAIL-SAFE MODE	13	Pedal Adjusting Sensor Circuit Check	64
MEMORY STORING AND KEYFOB INTERLOCK STORING	14	Mirror Sensor LH Circuit Check	65
MEMORY OPERATION	15	Mirror Sensor RH Circuit Check	67
ENTRY OPERATION	15	Sliding Switch Circuit Check	69
EXITING OPERATION	15	Reclining Switch Check	70

SE

Front Lifting Switch Circuit Check	72	Description	99
Rear Lifting Switch Circuit Check	73	Schematic	100
Power Seat Switch Ground Circuit Check	74	Wiring Diagram—HSEAT—	101
Pedal Adjusting Switch Circuit Check	75	FRONT SEAT	104
Door Mirror Remote Control Switch (Changeover Switch) Circuit Check	77	Removal and Installation	104
Door Mirror Remote Control Switch (Mirror Switch) Circuit Check	78	DRIVER SIDE POWER SEAT	104
Door Mirror Remote Control Switch Ground Circuit Check	80	PASSENGER SIDE MANUAL SEAT	106
Seat Memory Switch Circuit Check	80	REMOVAL	107
Seat Memory Indicator Lamp Circuit Check	82	INSTALLATION	107
Door Mirror Sensor Power Supply and Ground Cir- cuit Check	83	SEATBACK TRIM AND PAD	108
Detention Switch Circuit Check	84	REMOVAL OF SEATBACK ASSEMBLY	109
Key Switch Circuit Check (Without Intelligent Key)..	86	INSTALLATION OF SEATBACK ASSEMBLY ...	109
Key Switch Circuit Check (With Intelligent Key) ...	88	SEAT CUSHION TRIM AND PAD (POWER SEAT)	109
UART Communication Line Circuit Check	90	SEAT CUSHION TRIM AND PAD (MANUAL SEAT)	109
Lumber Support Circuit Check	91	REAR SEAT	111
POWER SEAT	93	Removal and Installation	111
Automatic Drive Positioner Interlocking Power Seat..	93	LH SIDE SEAT	111
Schematic	94	RH SIDE SEAT	113
Wiring Diagram—SEAT—/Driver Side Without Automatic Drive Positioner	95	REMOVAL	114
Wiring Diagram—SEAT—/Passenger Side	98	INSTALLATION	114
HEATED SEAT	99	REMOVAL OF REMOTE CONTROL LEVER ...	115
		INSTALLATION OF REMOTE CONTROL LEVER	115

PRECAUTIONS

PRECAUTIONS

PF:00001

Precautions for Supplemental Restraint System (SRS) “AIR BAG” and “SEAT BELT PRE-TENSIONER”

AIS003BH

The Supplemental Restraint System such as “AIR BAG” and “SEAT BELT PRE-TENSIONER”, used along with a front seat belt, helps to reduce the risk or severity of injury to the driver and front passenger for certain types of collision. This system includes seat belt switch inputs and dual stage front air bag modules. The SRS system uses the seat belt switches to determine the front air bag deployment, and may only deploy one front air bag, depending on the severity of a collision and whether the front occupants are belted or unbelted. Information necessary to service the system safely is included in the SRS and SB section of this Service Manual.

WARNING:

- To avoid rendering the SRS inoperative, which could increase the risk of personal injury or death in the event of a collision which would result in air bag inflation, all maintenance must be performed by an authorized NISSAN/INFINITI dealer.
- Improper maintenance, including incorrect removal and installation of the SRS, can lead to personal injury caused by unintentional activation of the system. For removal of Spiral Cable and Air Bag Module, see the SRS section.
- Do not use electrical test equipment on any circuit related to the SRS unless instructed to in this Service Manual. SRS wiring harnesses can be identified by yellow and/or orange harnesses or harness connectors.

Service Notice

AIS003BG

- When removing or installing various parts, place a cloth or padding onto the vehicle body to prevent scratches.
- Handle trim, molding, instruments, grille, etc. carefully during removing or installing. Be careful not to oil or damage them.
- Apply sealing compound where necessary when installing parts.
- When applying sealing compound, be careful that the sealing compound does not protrude from parts.
- When replacing any metal parts (for example body outer panel, members, etc.), be sure to take rust prevention measures.

Precautions for Work

AIS003BI

- When removing or disassembling each component, be careful not to damage or deform it. If a component may be subject to interference, be sure to protect it with a cloth.
- When removing (disengaging) components with a screwdriver or similar tool, be sure to wrap the component with a cloth or vinyl tape to protect it.
- Protect the removed parts with a cloth and keep them.
- Replace a deformed or damaged clip.
- If a part is specified as a non-reusable part, always replace it with new one.
- Be sure to tighten bolts and nuts securely to the specified torque.
- After re-installation is completed, be sure to check that each part works normally.
- Follow the steps below to clean components.
 - Water soluble foul: Dip a soft cloth into lukewarm water, and wring the water out of the cloth to wipe the fouled area.
Then rub with a soft and dry cloth.
 - Oily foul: Dip a soft cloth into lukewarm water with mild detergent (concentration: within 2 to 3%), and wipe the fouled area.
Then dip a cloth into fresh water, and wring the water out of the cloth to wipe the detergent off. Then rub with a soft and dry cloth.
- Do not use organic solvent such as thinner, benzene, alcohol, and gasoline.
- For genuine leather seats, use a genuine leather seat cleaner.

PREPARATION

PREPARATION

PFP:00002

Special Service Tools

AIS001T7

The actual shapes of Kent-Moore tools may differ from those of special service tools illustrated here.

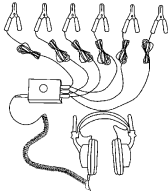
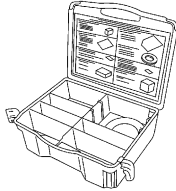
Tool number (Kent-Moore No.) Tool name	Description
(J-39570) Chassis ear  <small>SIIA0993E</small>	Locating the noise
(J-43980) NISSAN Squeak and Rattle Kit  <small>SIIA0994E</small>	Repairing the cause of noise

Commercial Service Tools

AIS001T8

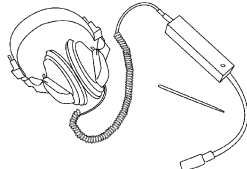
Tool name	Description
Engine ear  <small>SIIA0995E</small>	Locating the noise

SQUEAK AND RATTLE TROUBLE DIAGNOSES

SQUEAK AND RATTLE TROUBLE DIAGNOSES

PFP:00000

Work Flow

AIS0038Y

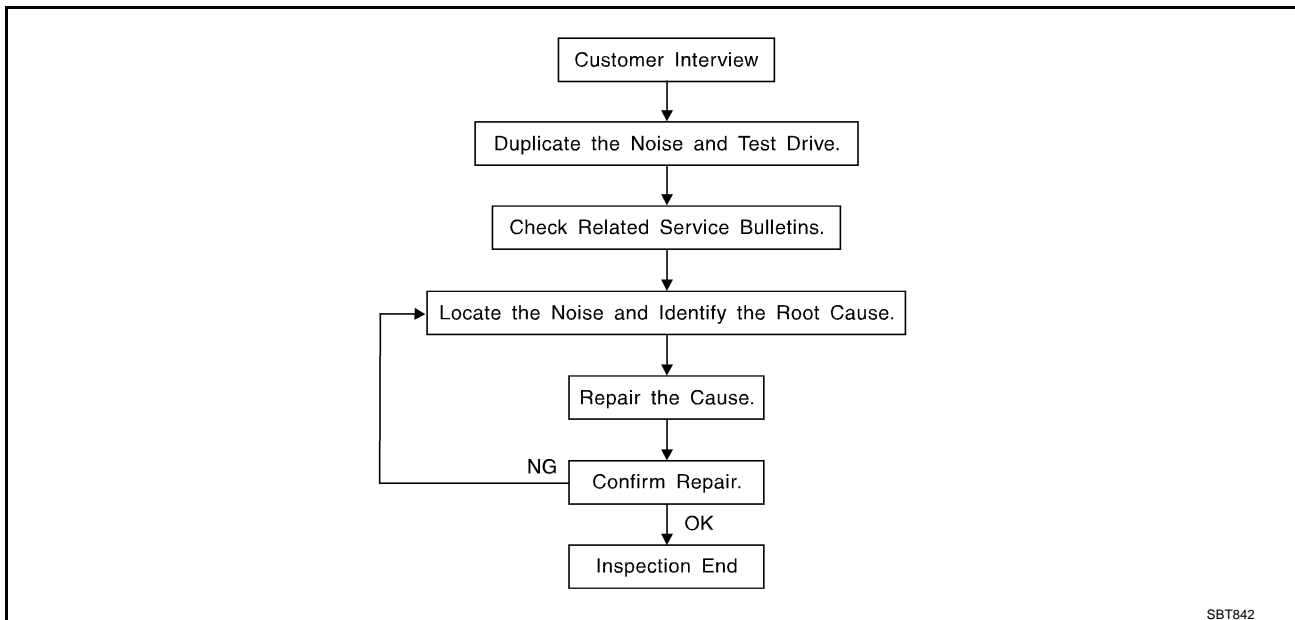

CUSTOMER INTERVIEW

Interview the customer if possible, to determine the conditions that exist when the noise occurs. Use the Diagnostic Worksheet during the interview to document the facts and conditions when the noise occurs and any customer's comments; refer to [SE-9, "Diagnostic Worksheet"](#). This information is necessary to duplicate the conditions that exist when the noise occurs.

- The customer may not be able to provide a detailed description or the location of the noise. Attempt to obtain all the facts and conditions that exist when the noise occurs (or does not occur).
- If there is more than one noise in the vehicle, be sure to diagnose and repair the noise that the customer is concerned about. This can be accomplished by test driving the vehicle with the customer.
- After identifying the type of noise, isolate the noise in terms of its characteristics. The noise characteristics are provided so the customer, service adviser and technician are all speaking the same language when defining the noise.
- Squeak—(Like tennis shoes on a clean floor)
Squeak characteristics include the light contact/fast movement/brought on by road conditions/hard surfaces=higher pitch noise/softer surfaces=lower pitch noises/edge to surface=chirping
- Creak—(Like walking on an old wooden floor)
Creak characteristics include firm contact/slow movement/twisting with a rotational movement/pitch dependent on materials/often brought on by activity.
- Rattle—(Like shaking a baby rattle)
Rattle characteristics include the fast repeated contact/vibration or similar movement/loose parts/missing clip or fastener/incorrect clearance.
- Knock—(Like a knock on a door)
Knock characteristics include hollow sounding/sometimes repeating/often brought on by driver action.
- Tick—(Like a clock second hand)
Tick characteristics include gentle contacting of light materials/loose components/can be caused by driver action or road conditions.
- Thump—(Heavy, muffled knock noise)
Thump characteristics include softer knock/dead sound often brought on by activity.
- Buzz—(Like a bumble bee)
Buzz characteristics include high frequency rattle/firm contact.
- Often the degree of acceptable noise level will vary depending upon the person. A noise that you may judge as acceptable may be very irritating to the customer.
- Weather conditions, especially humidity and temperature, may have a great effect on noise level.

SQUEAK AND RATTLE TROUBLE DIAGNOSES

DUPLICATE THE NOISE AND TEST DRIVE

If possible, drive the vehicle with the customer until the noise is duplicated. Note any additional information on the Diagnostic Worksheet regarding the conditions or location of the noise. This information can be used to duplicate the same conditions when you confirm the repair.

If the noise can be duplicated easily during the test drive, to help identify the source of the noise, try to duplicate the noise with the vehicle stopped by doing one or all of the following:

- 1) Close a door.
 - 2) Tap or push/pull around the area where the noise appears to be coming from.
 - 3) Rev the engine.
 - 4) Use a floor jack to recreate vehicle "twist".
 - 5) At idle, apply engine load (electrical load, half-clutch on M/T model, drive position on A/T model).
 - 6) Raise the vehicle on a hoist and hit a tire with a rubber hammer.
- Drive the vehicle and attempt to duplicate the conditions the customer states exist when the noise occurs.
 - If it is difficult to duplicate the noise, drive the vehicle slowly on an undulating or rough road to stress the vehicle body.

CHECK RELATED SERVICE BULLETINS

After verifying the customer concern or symptom, check ASIST for Technical Service Bulletins (TSBs) related to that concern or symptom.

If a TSB relates to the symptom, follow the procedure to repair the noise.

LOCATE THE NOISE AND IDENTIFY THE ROOT CAUSE

1. Narrow down the noise to a general area. To help pinpoint the source of the noise, use a listening tool (Chassis Ear: J-39570, Engine Ear and mechanics stethoscope).
2. Narrow down the noise to a more specific area and identify the cause of the noise by:
 - removing the components in the area that you suspect the noise is coming from.
Do not use too much force when removing clips and fasteners, otherwise clips and fastener can be broken or lost during the repair, resulting in the creation of new noise.
 - tapping or pushing/pulling the component that you suspect is causing the noise.
Do not tap or push/pull the component with excessive force, otherwise the noise will be eliminated only temporarily.
 - feeling for a vibration with your hand by touching the component(s) that you suspect is (are) causing the noise.
 - placing a piece of paper between components that you suspect are causing the noise.
 - looking for loose components and contact marks.
Refer to [SE-7, "Generic Squeak and Rattle Troubleshooting"](#) .

REPAIR THE CAUSE

- If the cause is a loose component, tighten the component securely.
- If the cause is insufficient clearance between components:
 - separate components by repositioning or loosening and retightening the component, if possible.
 - insulate components with a suitable insulator such as urethane pads, foam blocks, felt cloth tape or urethane tape. A Nissan Squeak and Rattle Kit (J-43980) is available through your authorized Nissan Parts Department.

CAUTION:

Do not use excessive force as many components are constructed of plastic and may be damaged.

Always check with the Parts Department for the latest parts information.

The following materials are contained in the Nissan Squeak and Rattle Kit (J-43980). Each item can be ordered separately as needed.

URETHANE PADS [1.5 mm (0.059 in) thick]

Insulates connectors, harness, etc.

76268-9E005: 100 × 135 mm (3.94 × 5.31 in)/76884-71L01: 60 × 85 mm (2.36 × 3.35 in)/76884-71L02: 15 × 25 mm (0.59 × 0.98 in)

INSULATOR (Foam blocks)

Insulates components from contact. Can be used to fill space behind a panel.

73982-9E000: 45 mm (1.77 in) thick, 50 × 50 mm (1.97 × 1.97 in)/73982-50Y00: 10 mm (0.39 in) thick, 50 × 50 mm (1.97 × 1.97 in)

SQUEAK AND RATTLE TROUBLE DIAGNOSES

INSULATOR (Light foam block)

80845-71L00: 30 mm (1.18 in) thick, 30 × 50 mm (1.18 × 1.97 in)

FELT CLOTHTAPE

Used to insulate where movement does not occur. Ideal for instrument panel applications.

68370-4B000: 15 × 25 mm (0.59 × 0.98 in) pad/68239-13E00: 5 mm (0.20 in) wide tape roll

The following materials, not found in the kit, can also be used to repair squeaks and rattles.

UHMW (TEFLON) TAPE

Insulates where slight movement is present. Ideal for instrument panel applications.

SILICONE GREASE

Used in of UHMW tape that will be visible or not fit.

Note: Will only last a few months.

SILICONE SPRAY

Use when grease cannot be applied.

DUCT TAPE

Use to eliminate movement.

CONFIRM THE REPAIR

Confirm that the cause of a noise is repaired by test driving the vehicle. Operate the vehicle under the same conditions as when the noise originally occurred. Refer to the notes on the Diagnostic Worksheet.

Generic Squeak and Rattle Troubleshooting

AI50038Z

Refer to Table of Contents for specific component removal and installation information.

INSTRUMENT PANEL

Most incidents are caused by contact and movement between:

1. Cluster lid A and instrument panel
2. Acrylic lens and combination meter housing
3. Instrument panel to front pillar garnish
4. Instrument panel to windshield
5. Instrument panel mounting pins
6. Wiring harnesses behind the combination meter
7. A/C defroster duct and duct joint

These incidents can usually be located by tapping or moving the components to duplicate the noise or by pressing on the components while driving to stop the noise. Most of these incidents can be repaired by applying felt cloth tape or silicon spray (in hard to reach areas). Urethane pads can be used to insulate wiring harness.

CAUTION:

Do not use silicone spray to isolate a squeak or rattle. If you saturate the area with silicone, you will not be able to recheck the repair.

CENTER CONSOLE

Components to pay attention to include:

1. Shifter assembly cover to finisher
2. A/C control unit and cluster lid C
3. Wiring harnesses behind audio and A/C control unit

The instrument panel repair and isolation procedures also apply to the center console.

DOORS

Pay attention to the:

1. Finisher and inner panel making a slapping noise
2. Inside handle escutcheon to door finisher
3. Wiring harnesses tapping
4. Door striker out of alignment causing a popping noise on starts and stops

Tapping or moving the components or pressing on them while driving to duplicate the conditions can isolate many of these incidents. You can usually insulate the areas with felt cloth tape or insulator foam blocks from the Nissan Squeak and Rattle Kit (J-43980) to repair the noise.

A
B
C
D
E
F
G
H
SE
J
K
L
M

SQUEAK AND RATTLE TROUBLE DIAGNOSES

TRUNK

Trunk noises are often caused by a loose jack or loose items put into the trunk by the owner. In addition look for:

1. Trunk lid dumpers out of adjustment
2. Trunk lid striker out of adjustment
3. Trunk lid torsion bars knocking together
4. A loose license plate or bracket

Most of these incidents can be repaired by adjusting, securing or insulating the item(s) or component(s) causing the noise.

SUNROOF/HEADLINING

Noises in the sunroof/headlining area can often be traced to one of the following:

1. Sunroof lid, rail, linkage or seals making a rattle or light knocking noise
2. Sunvisor shaft shaking in the holder
3. Front or rear windshield touching headlining and squeaking

Again, pressing on the components to stop the noise while duplicating the conditions can isolate most of these incidents. Repairs usually consist of insulating with felt cloth tape.

SEATS

When isolating seat noise it's important to note the position the seat is in and the load placed on the seat when the noise is present. These conditions should be duplicated when verifying and isolating the cause of the noise.

Cause of seat noise include:

1. Headrest rods and holder
2. A squeak between the seat pad cushion and frame
3. Seatback lock and bracket

These noises can be isolated by moving or pressing on the suspected components while duplicating the conditions under which the noise occurs. Most of these incidents can be repaired by repositioning the component or applying urethane tape to the contact area.

UNDERHOOD

Some interior noise may be caused by components under the hood or on the engine wall. The noise is then transmitted into the passenger compartment.

Causes of transmitted underhood noise include:

1. Any component mounted to the engine wall
2. Components that pass through the engine wall
3. Engine wall mounts and connectors
4. Loose radiator mounting pins
5. Hood bumpers out of adjustment
6. Hood striker out of adjustment

These noises can be difficult to isolate since they cannot be reached from the interior of the vehicle. The best method is to secure, move or insulate one component at a time and test drive the vehicle. Also, engine RPM or load can be changed to isolate the noise. Repairs can usually be made by moving, adjusting, securing, or insulating the component causing the noise.

SQUEAK AND RATTLE TROUBLE DIAGNOSES

Diagnostic Worksheet

AIS00390

A
B
C
D
E
F
G
H
SE
J
K
L
M

SQUEAK & RATTLE DIAGNOSTIC WORKSHEET

Dear Nissan Customer:

We are concerned about your satisfaction with your Nissan vehicle. Repairing a squeak or rattle sometimes can be very difficult. To help us fix your Nissan right the first time, please take a moment to note the area of the vehicle where the squeak or rattle occurs and under what conditions. You may be asked to take a test drive with a service advisor or technician to ensure we confirm the noise you are hearing.

I. WHERE DOES THE NOISE COME FROM? (circle the area of the vehicle)

The illustrations are for reference only, and may not reflect the actual configuration of your vehicle.

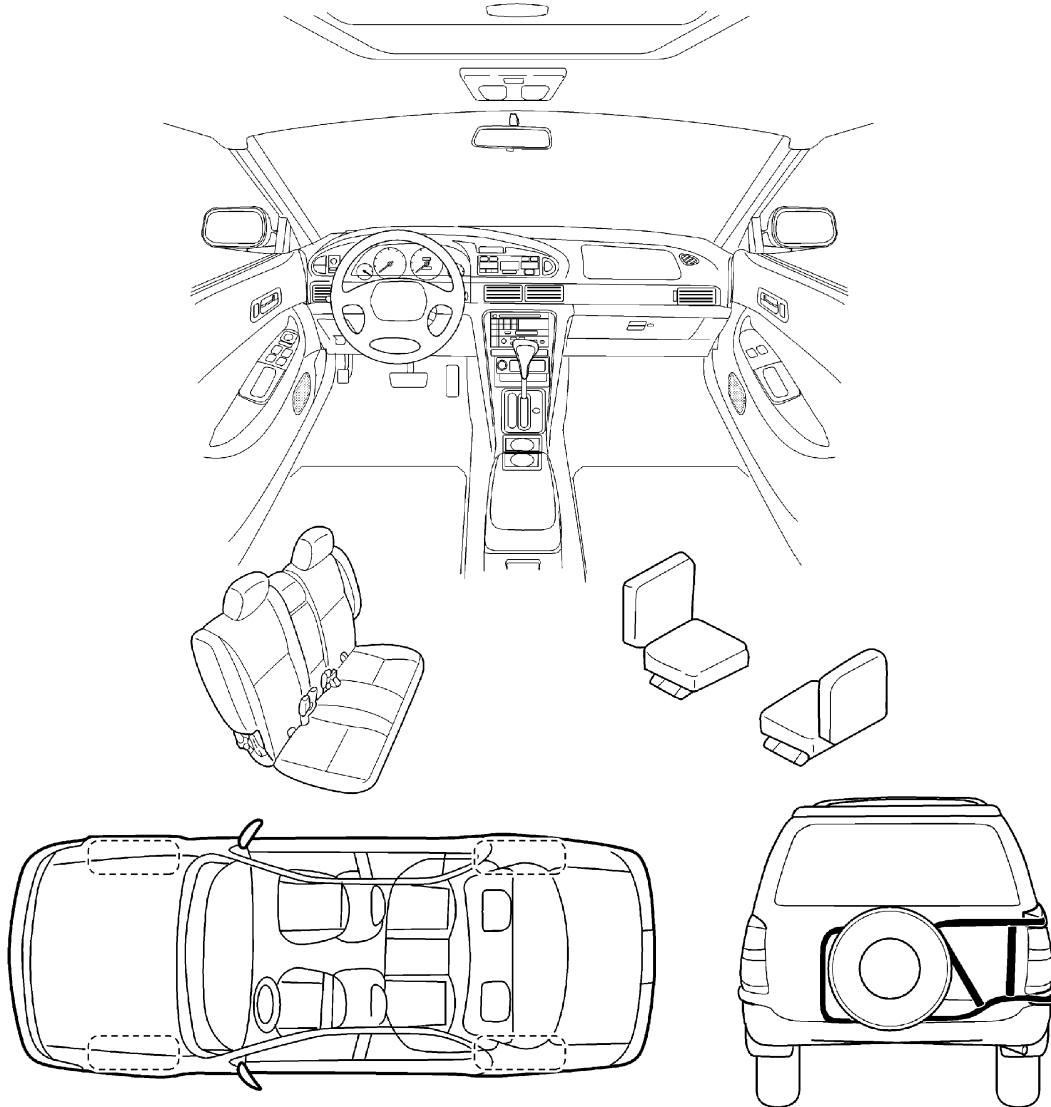

Continue to the back of the worksheet and briefly describe the location of the noise or rattle. In addition, please indicate the conditions which are present when the noise occurs.

PIIB0723E

SQUEAK AND RATTLE TROUBLE DIAGNOSES

SQUEAK & RATTLE DIAGNOSTIC WORKSHEET- page 2

Briefly describe the location where the noise occurs:

II. WHEN DOES IT OCCUR? (check the boxes that apply)

- | | |
|--|---|
| <input type="checkbox"/> anytime | <input type="checkbox"/> after sitting out in the sun |
| <input type="checkbox"/> 1 st time in the morning | <input type="checkbox"/> when it is raining or wet |
| <input type="checkbox"/> only when it is cold outside | <input type="checkbox"/> dry or dusty conditions |
| <input type="checkbox"/> only when it is hot outside | <input type="checkbox"/> other: _____ |

III. WHEN DRIVING:

- through driveways
- over rough roads
- over speed bumps
- only at about ____ mph
- on acceleration
- coming to a stop
- on turns : left, right or either (circle)
- with passengers or cargo
- other: _____
- after driving ____ miles or ____ minutes

IV. WHAT TYPE OF NOISE?

- squeak (like tennis shoes on a clean floor)
- creak (like walking on an old wooden floor)
- rattle (like shaking a baby rattle)
- knock (like a knock on a door)
- tick (like a clock second hand)
- thump (heavy, muffled knock noise)
- buzz (like a bumble bee)

TO BE COMPLETED BY DEALERSHIP PERSONNEL

Test Drive Notes:

	YES	NO	Initials of person performing
Vehicle test driven with customer	<input type="checkbox"/>	<input type="checkbox"/>	_____
- Noise verified on test drive	<input type="checkbox"/>	<input type="checkbox"/>	_____
- Noise source located and repaired	<input type="checkbox"/>	<input type="checkbox"/>	_____
- Follow up test drive performed to confirm repair	<input type="checkbox"/>	<input type="checkbox"/>	_____

VIN: _____ Customer Name: _____

W.O. #: _____ Date: _____

This form must be attached to Work Order

SBT844







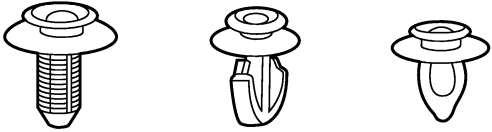

CLIP AND FASTENER

CLIP AND FASTENER

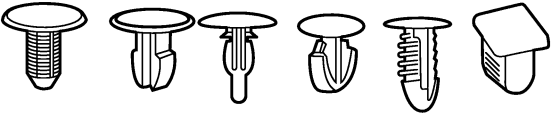
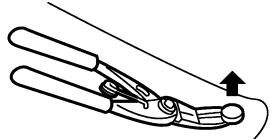
PFP:76906

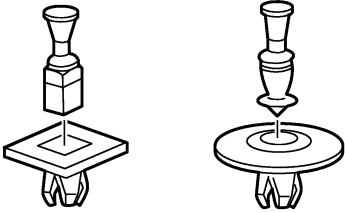
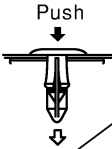
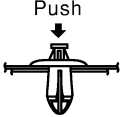
Clip and Fastener

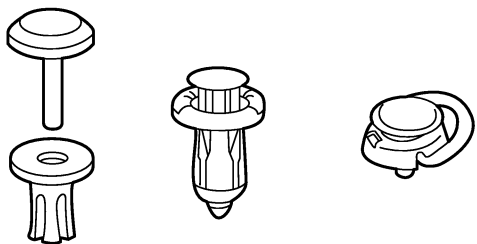
AIS003C2

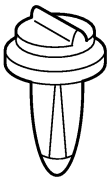
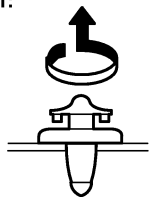
Symbol No.	Shapes	Removal & Installation
<p>C101</p> 		<p>Removal: Remove by bending up with flat-bladed screwdrivers or clip remover.</p> 
<p>C103</p> 		<p>Removal: Remove with a clip remover.</p> 
<p>C203</p> 		<p>Removal: Push center pin to catching position. (Do not remove center pin by hitting it.)</p> <p>Push</p>  <p>Installation:</p> <p>Push</p> 
<p>C205</p> 		<p>Removal: Flat-bladed screwdriver</p>  <p>Clip</p> <p>Finisher</p>
<p>C206</p> 		<p>Removal:</p> 

A
B
C
D
E
F
G
H
SE
J
K
L
M

SIIA0315E

AUTOMATIC DRIVE POSITIONER

AUTOMATIC DRIVE POSITIONER

PFP:28491

System Description MANUAL OPERATION

AIS003GD

The driving position [seat position pedal position (Accelerator, brake) and door mirror position] can be adjusted with the power seat switch or pedal adjusting switch or door mirror remote control switch.

NOTE:

- The door mirrors can be manually operated with the ignition switch turned ACC or ON.
- Only when CVT selector lever is in P position, adjusting pedal operates (except when ignition switch turned to OFF).
- If detection switch error is detected, manual adjustable pedal operation cannot be performed when ignition switch turns ON.

AUTOMATIC OPERATION

- The system automatically moves the driver seat to facilitate entry/exit to/from the vehicle. The driver seat control unit can also store the optimum driving positions (driver seat, pedal position and door mirror position) for 2 people. If the driver is changes, one-touch operation allows changing to the other driving position.
- The settings (ON/OFF) of the automatic sliding seat (Entry/Exiting operation) at entry/exit can be changed as desired, using the display unit in the center of the instrument panel. The set content is transmitted by CAN communication, from display unit (without NAVI) or display control unit (with NAVI) to driver seat control unit.
- Using CONSULT-II, the seat slide a mount at entry/exit setting can be changed.

Function	Description
Memory operation	The seat, pedal (accelerator, brake) and door mirror move to the stored driving position by pushing memory switch (1 or 2).
Entry/Exiting function	Exiting operation At Exit, the seat moves backward. (Exiting position)
	Entry operation At entry, the seat returns from Exiting position to the previous driving position before the Exiting operation.
Keyfob interlock operation	Perform memory operation, turnout operation and return operation by pressing keyfob unlock button.

NOTE:

- Disconnecting the battery erases the stored memory.
- After connecting the battery, insert the key into the ignition cylinder and turn the driver door switch ON (open)→OFF (close)→ON (open), the Entry/ Exiting function becomes possible.
- After Exiting operation is carried out, return operation can be operated.

Auto operation temporary stop conditions.	When ignition switch turned to START during memory switch operation and return operation, memory switch operation and return operation is stopped.
Auto operation stop conditions.	<ul style="list-style-type: none"> ● When the vehicle speed becomes 7 km/h (4 MPH) or higher. (memory switch operation and entry operation) ● When the setting switch, memory switch 1, or 2 are pressed. ● When CVT selector lever is in any position other than P. ● When the door mirror remote control switch is operated (when ignition switch or ACC switch turned to ON). ● When power seat switch turned ON. ● When pedal adjusting switch turned ON. ● When driver seat sliding Entry/Exiting setting is OFF (entry/exiting operation).

NOTE:

During automatic operation, if the ignition switch is turned ON→START, the automatic operation is suspended. When the ignition switch returns to ON, it resumes.

AUTOMATIC DRIVE POSITIONER

FAIL- SAFE MODE

When any manual and automatic operations are not performed, if any motor operations of seats or pedals are detected for T2 or more, status is judged "Output error".

OPERATED PORTION	T2
Seat sliding	Approx. 0.1 sec.
Seat reclining	Same as above
Seat lifting (Front)	Same as above
Seat lifting (Rear)	Same as above
Pedal adjust	Same as above

CANCEL OF FAIL-SAFE MODE

The mode is cancelled when the selector lever is shifted to P position from any other position.

A

B

C

D

E

F

G

H

SE

J

K

L

M

AUTOMATIC DRIVE POSITIONER

MEMORY STORING AND KEYFOB INTERLOCK STORING

- Store the 2 driving positions and shifts to the stored driving position with the memory switch.
- Keyfob interlock function is set simultaneously with setting driving position memory. It can set driving position to memory position.

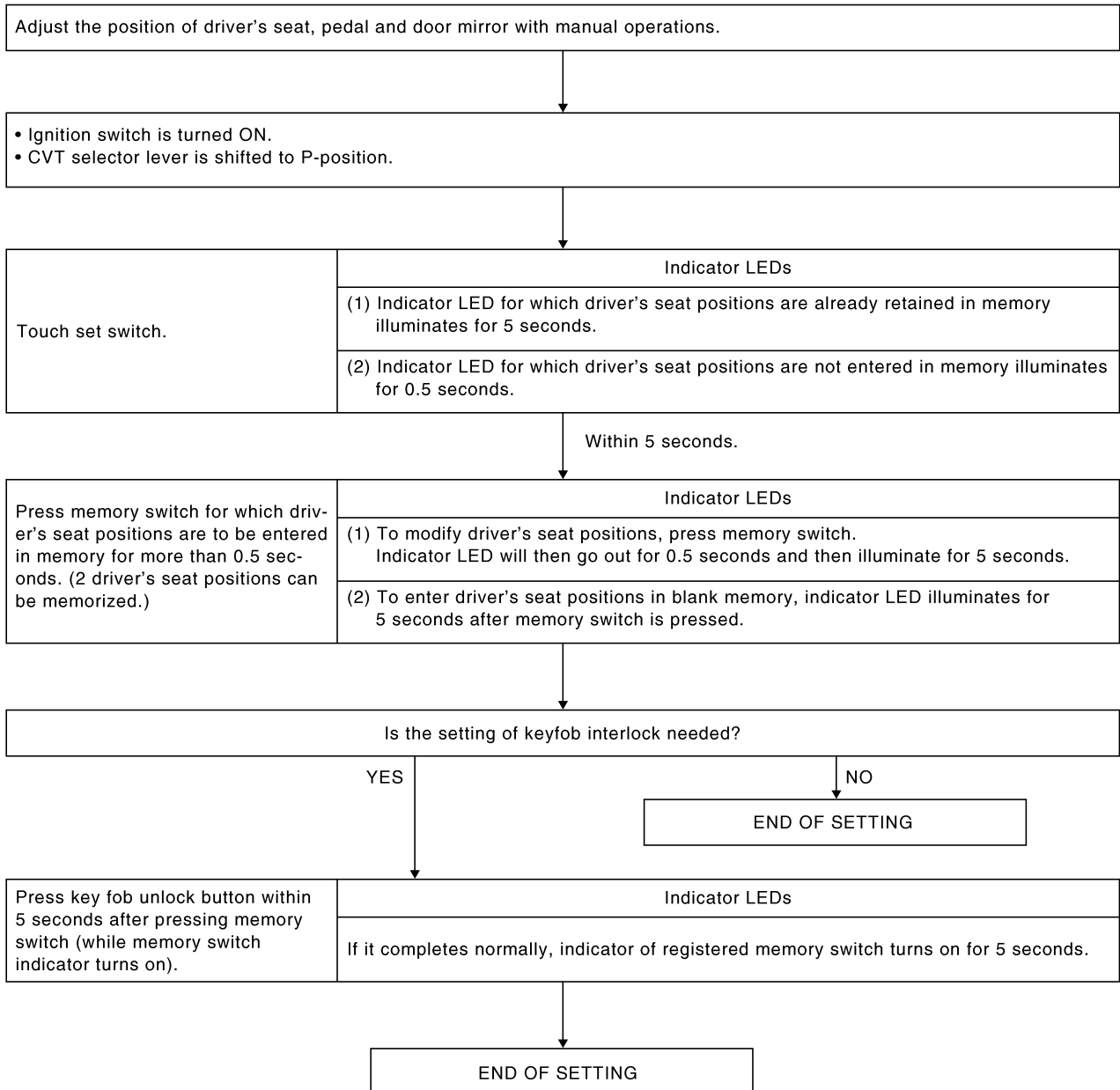

PIIB3488E

NOTE:

- If another keyfob interlock function setting is performed by same key, newly registered setting is valid.
- If new memory string is performed to memory switch that already set keyfob interlock function, keyfob interlock function setting is reset.
- If keyfob does not set previously, keyfob interlock function cannot set.

AUTOMATIC DRIVE POSITIONER

MEMORY OPERATION

Selecting the memorized position.

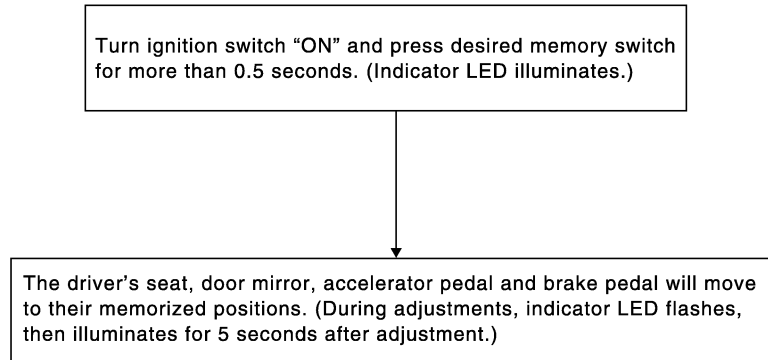

PIIA4798E

NOTE:

The driver's seat position and pedal adjustment functions (see the following table) operate simultaneously in the order of priority.

Priority	Function	Priority	Function
1	Seat sliding, (door mirror LH/RH)*	4	Seat lifter-FR
2	Pedal	5	Seat lifter-RR
3	Seat reclining		

*: In conjunction with sliding the seat, the door mirrors are positioned.

ENTRY OPERATION

When the seat are on the exiting positions, the following operation moves the seat to the previous position before the exiting operation.

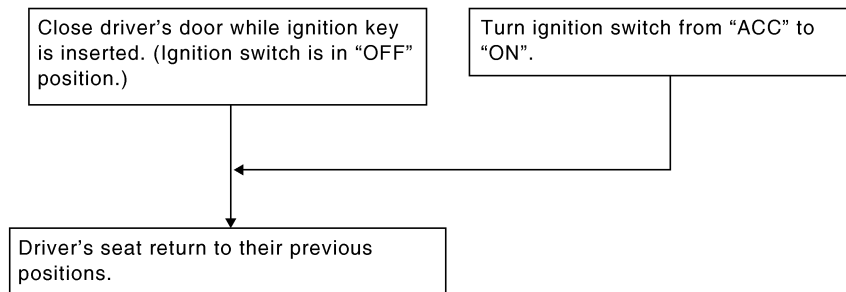

PIIB2805E

EXITING OPERATION

At Entry/Exiting, the seat are automatically moved to the exiting position.

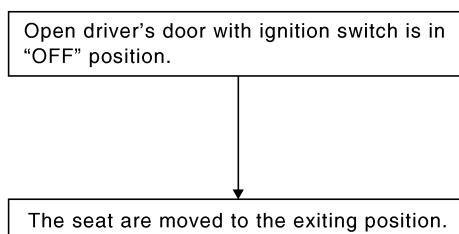

PIIB2806E

AUTOMATIC DRIVE POSITIONER

KEYFOB INTERLOCK OPERATION

- The system performs memory operation, exiting operation and return operation by pressing keyfob unlock button.

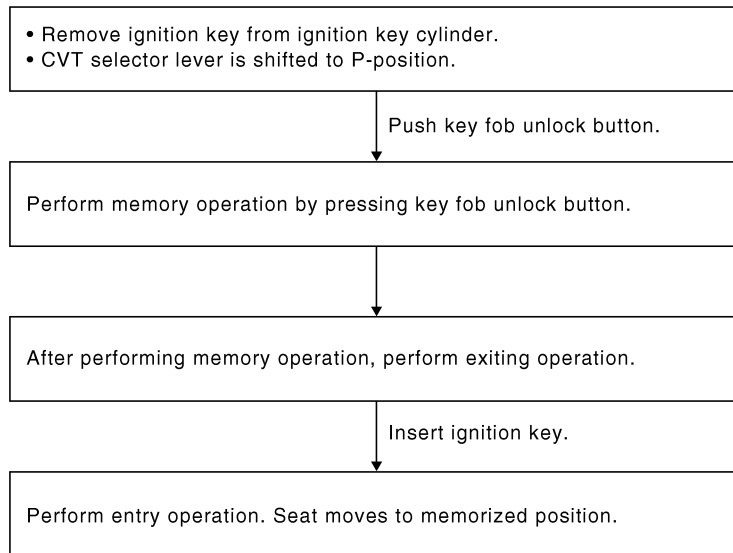

PIIA4797E

NOTE:

- If Entry/Exiting operation is cancelled, the system performs memory operation only.
- If ignition switch turns ON in the middle of memory operation, the system does not perform exiting operation after memory operation.
- If ignition switch turns ON in the middle of exiting operation, entry operation starts at that time.

AUTOMATIC DRIVE POSITIONER

Component Parts And Harness Connector Location

AIS003GE

A
B
C
D
E
F
G
H
SE
J
K
L
M

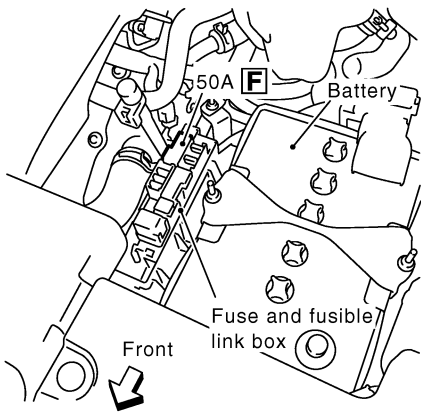

Driver side view with lower instrument panel removed

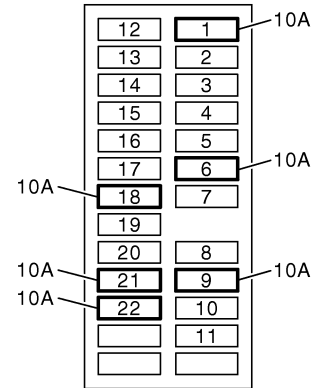
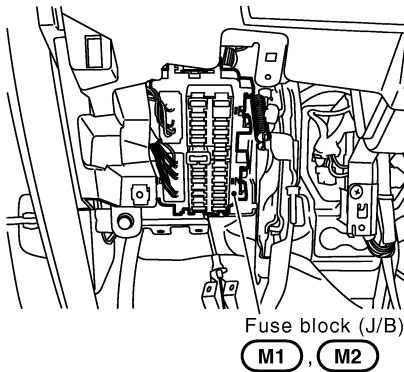

Fuse block (J/B) fuse layout

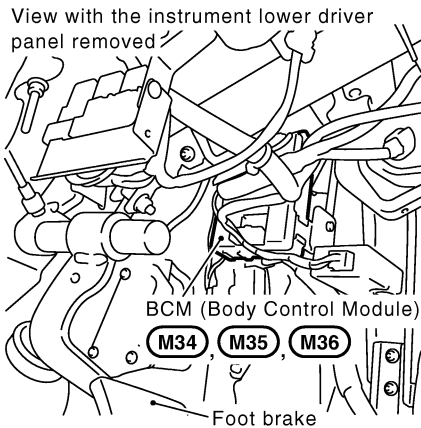

View with the instrument lower driver panel removed

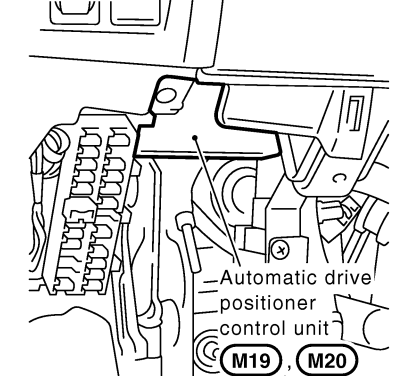

View with the audio unit removed

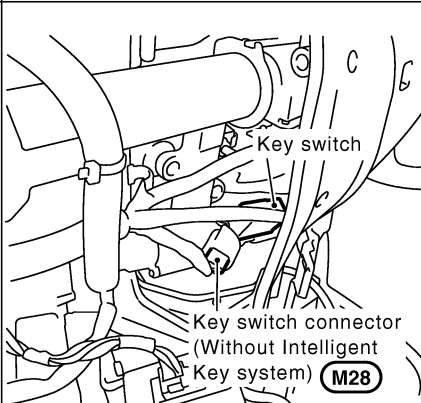
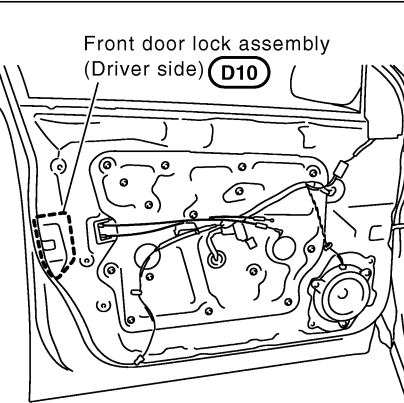
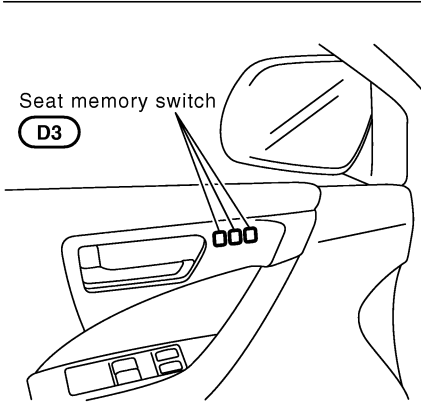
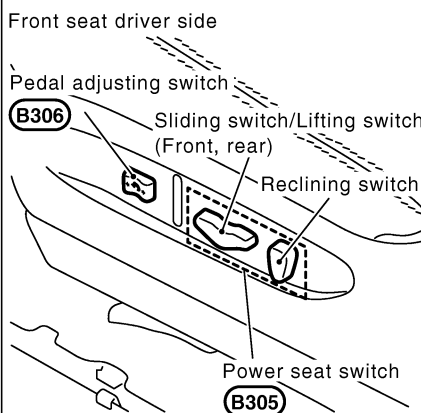
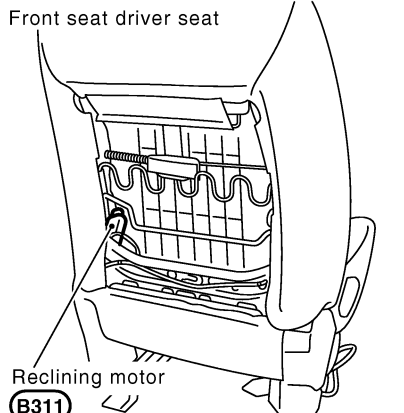
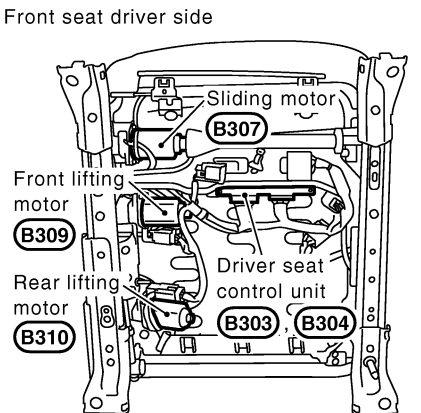
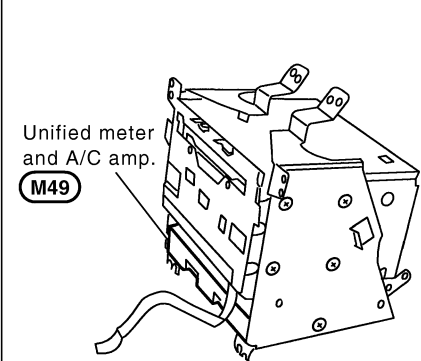

PIIB3194E

AUTOMATIC DRIVE POSITIONER

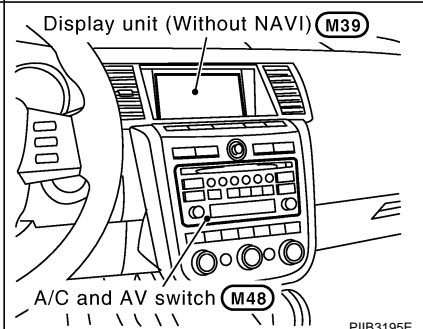
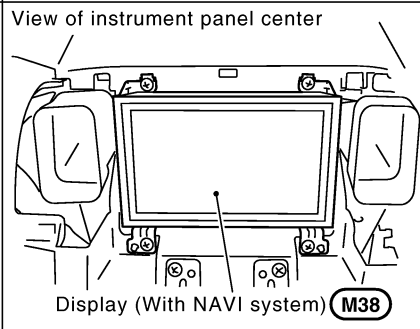
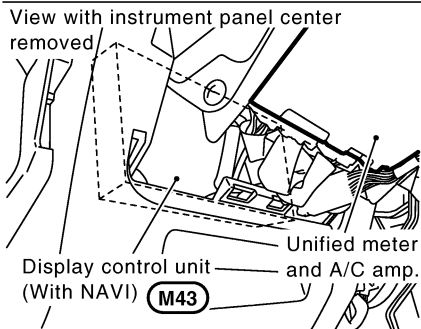
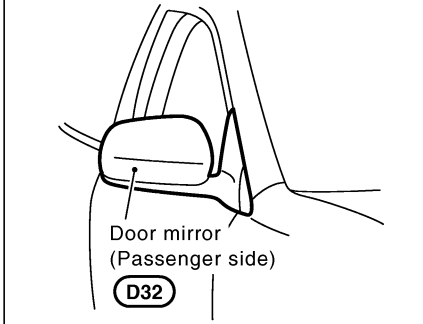
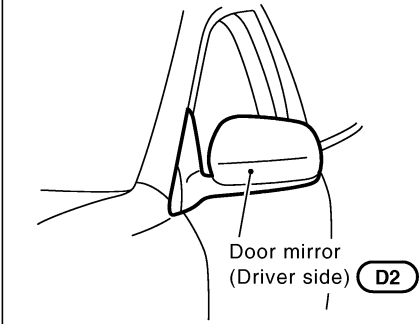
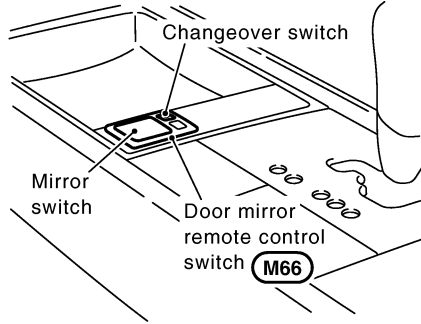
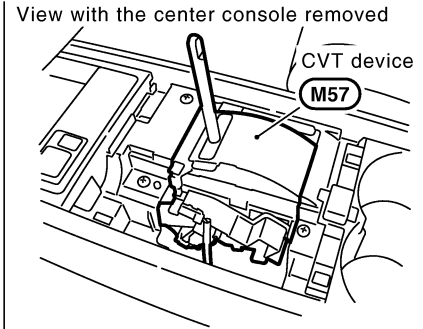
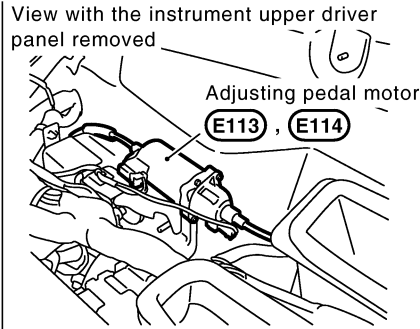
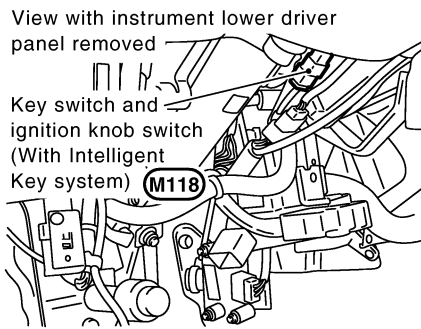

CAN Communication System Description

AIS003KJ

CAN (Controller Area Network) is a serial communication line for real time application. It is an on-vehicle multiplex communication line with high data communication speed and excellent error detection ability. Many electronic control units are equipped onto a vehicle, and each control unit shares information and links with other control units during operation (not independent). In CAN communication, control units are connected with 2 communication lines (CAN H line, CAN L line) allowing a high rate of information transmission with less wiring. Each control unit transmits/receives data but selectively reads required data only.

CAN Communication Unit

AIS003KK

Refer to [LAN-29. "CAN Communication Unit"](#).

AUTOMATIC DRIVE POSITIONER

Schematic

AIS003GG

A
B
C
D
E
F
G
H
SE
J
K
L
M

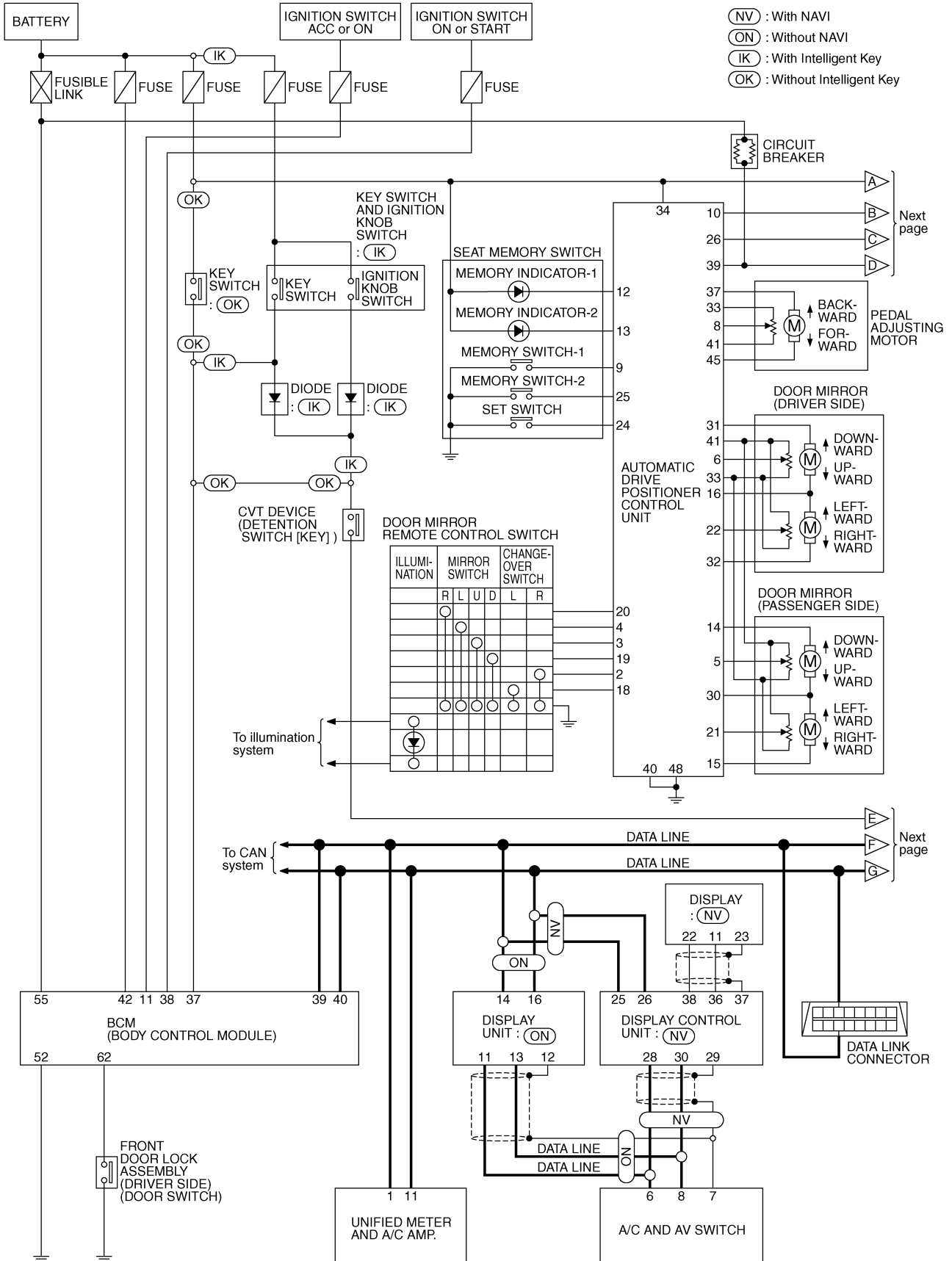

TIWB0182E

AUTOMATIC DRIVE POSITIONER

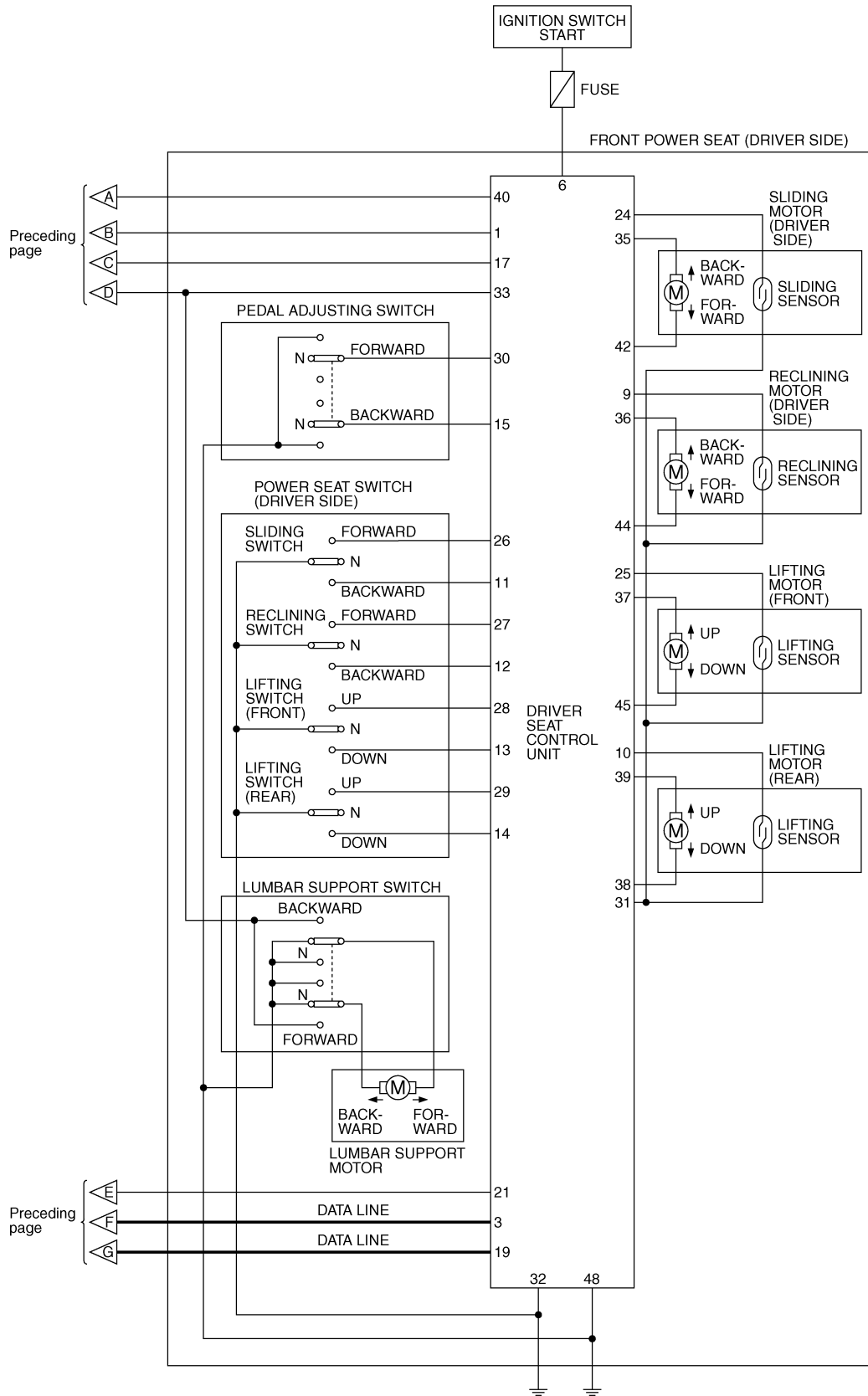

TIWA0516E

AUTOMATIC DRIVE POSITIONER

Wiring Diagram—AUT/DP—

AIS003GH

SE-AUT/DP-01

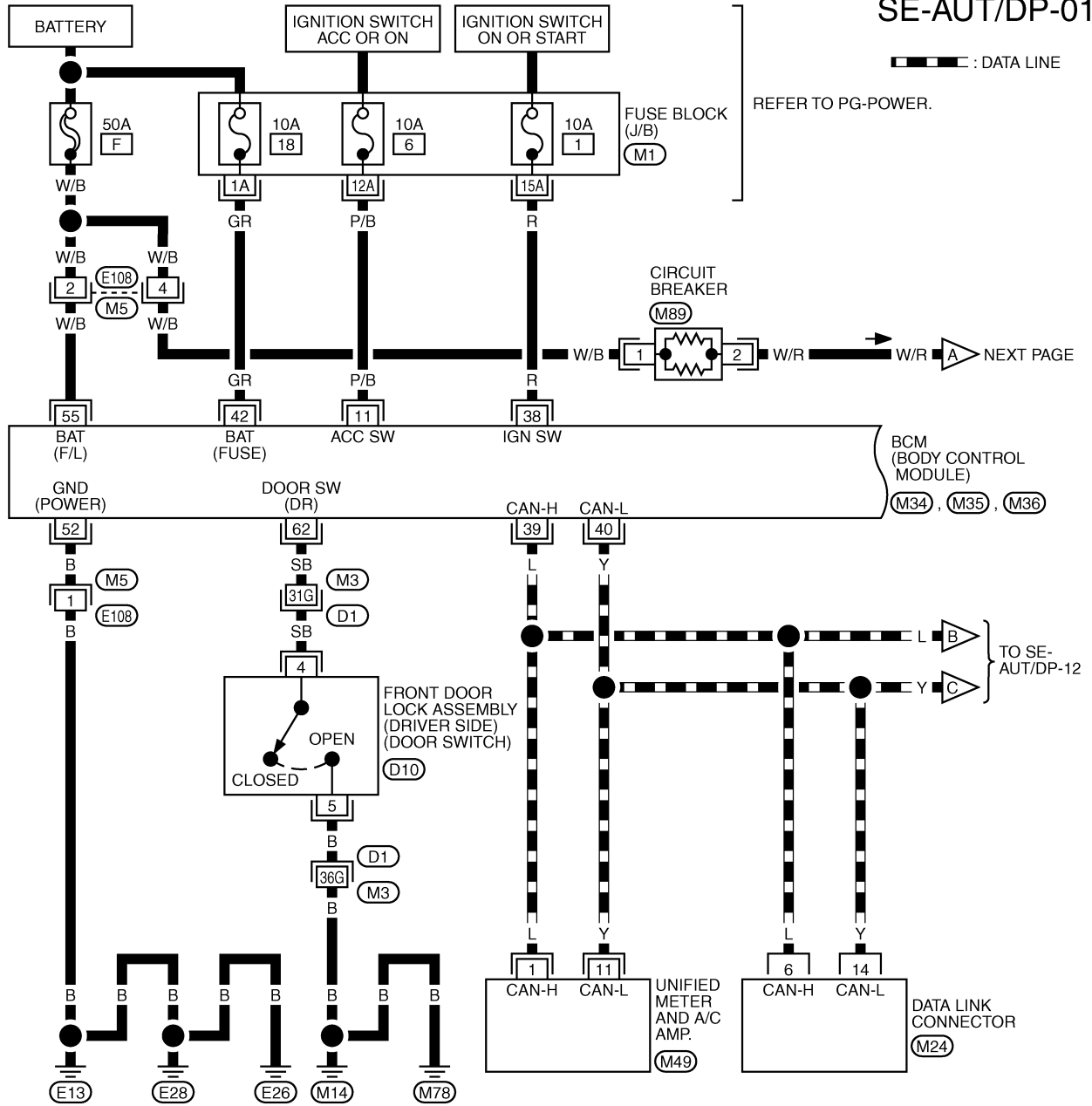

(M5)
W

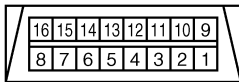

(M24)
W

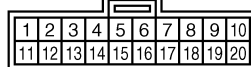

(M49)
GR



(M89)
W

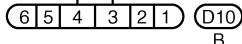

(D10)
B

REFER TO THE FOLLOWING.

(D1) -SUPER MULTIPLE JUNCTION (SMJ)

(M1) -FUSE BLOCK-JUNCTION BOX (J/B)

(M34), (M35), (M36)

-ELECTRICAL UNITS

TIWB0183E

AUTOMATIC DRIVE POSITIONER

SE-AUT/DP-02

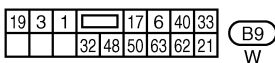
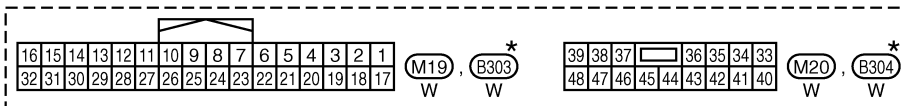
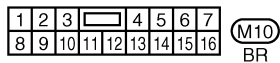
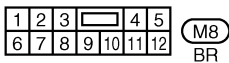
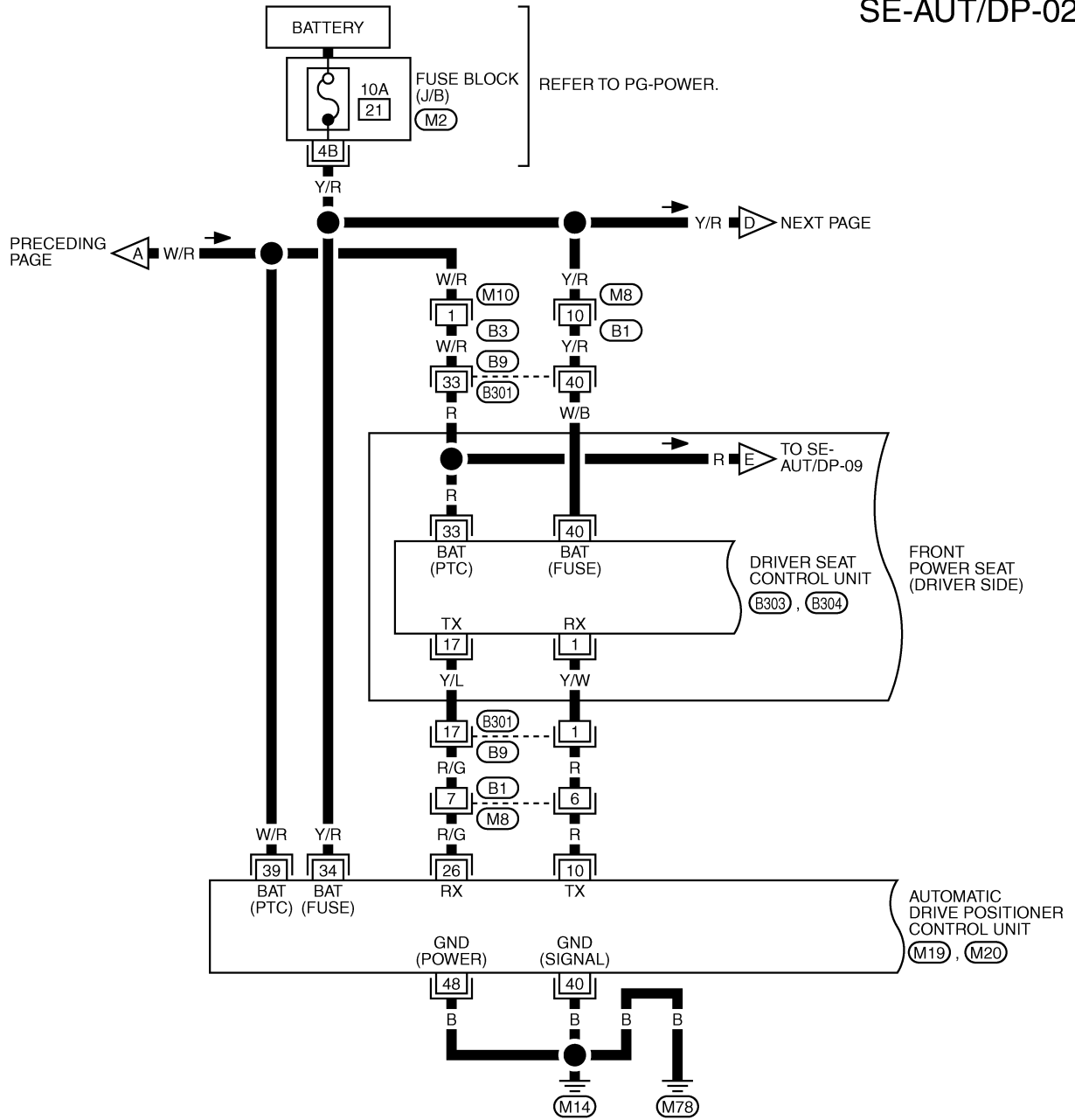

*: THIS CONNECTOR IS NOT SHOWN IN "HARNESS LAYOUT", PG SECTION.

REFER TO THE FOLLOWING.
(M2) -FUSE BLOCK-JUNCTION BOX (J/B)

TIWB0184E

AUTOMATIC DRIVE POSITIONER

SE-AUT/DP-03

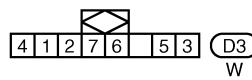
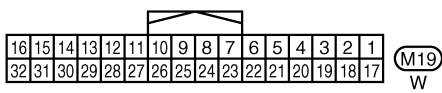
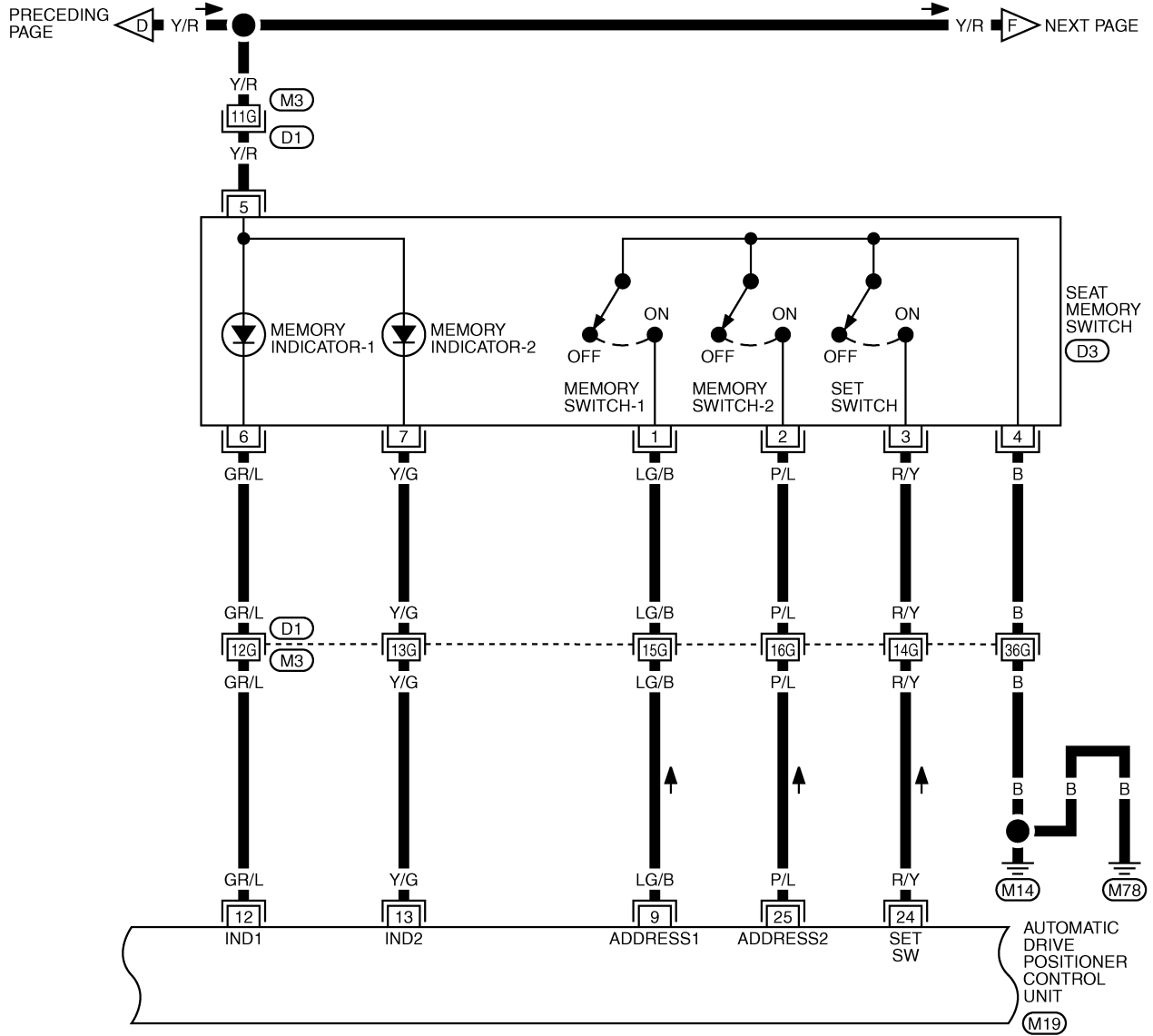

REFER TO THE FOLLOWING.
 (D1) -SUPER MULTIPLE JUNCTION (SMJ)

TIWB0185E

AUTOMATIC DRIVE POSITIONER

SE-AUT/DP-04

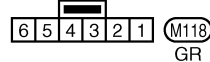
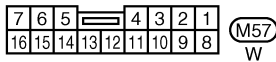
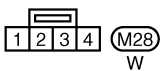
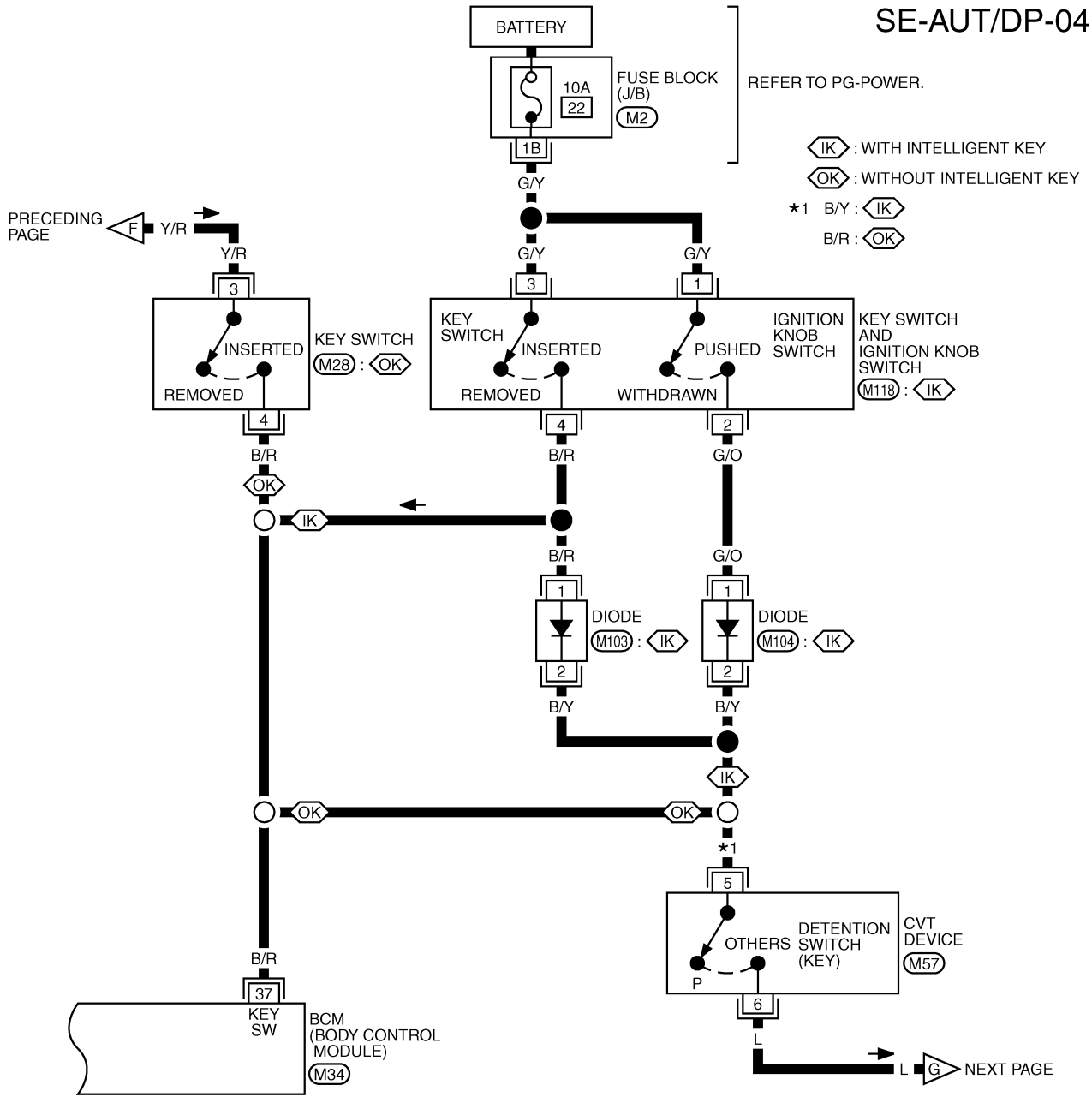

REFER TO THE FOLLOWING.
 (M2) -FUSE BLOCK-JUNCTION BOX (J/B)
 (M34) -ELECTRICAL UNITS

T1WB0186E

AUTOMATIC DRIVE POSITIONER

SE-AUT/DP-05

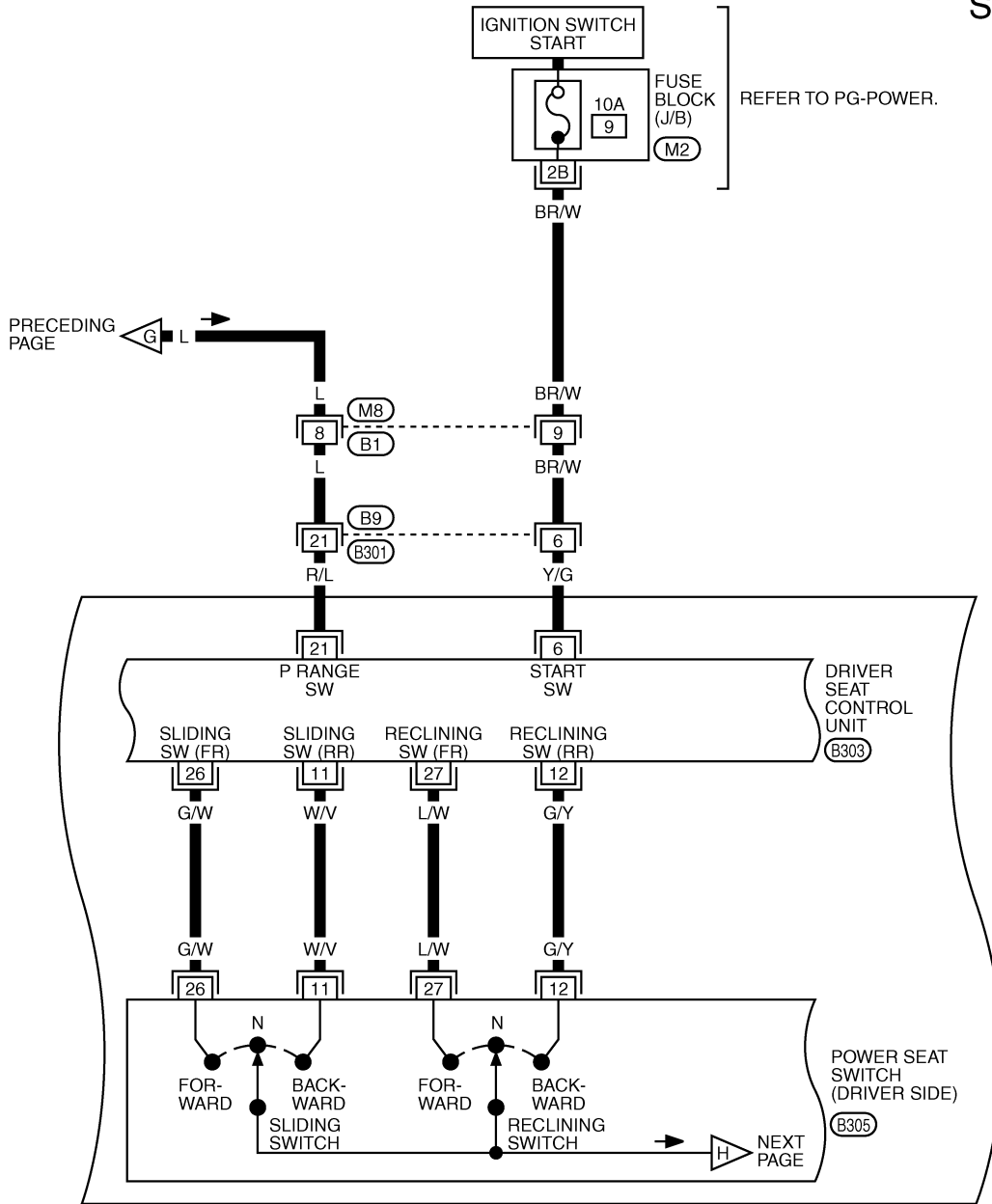

A
B
C
D
E
F
G
H
SE
J
K
L
M

1	2	3	4	5
6	7	8	9	10
11	12			

(M8) BR

19	3	1	17	6	40	33
			32	48	50	63
			62	21		

(B9) W

16	15	14	13	12	11	10	9	8	7	6	5	4	3	2	1
32	31	30	29	28	27	26	25	24	23	22	21	20	19	18	17

(B303) W

11	14	12	27
26	29	32A	13

(B305) W

REFER TO THE FOLLOWING.
(M2) - FUSE BLOCK-JUNCTION BOX (J/B)

*: THIS CONNECTOR IS NOT SHOWN IN "HARNESS LAYOUT", PG SECTION.

TIWB0187E

AUTOMATIC DRIVE POSITIONER

SE-AUT/DP-06

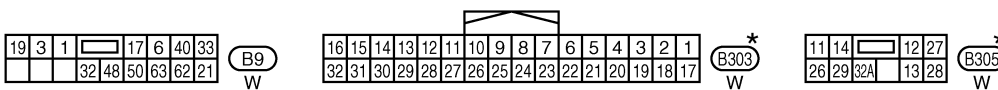
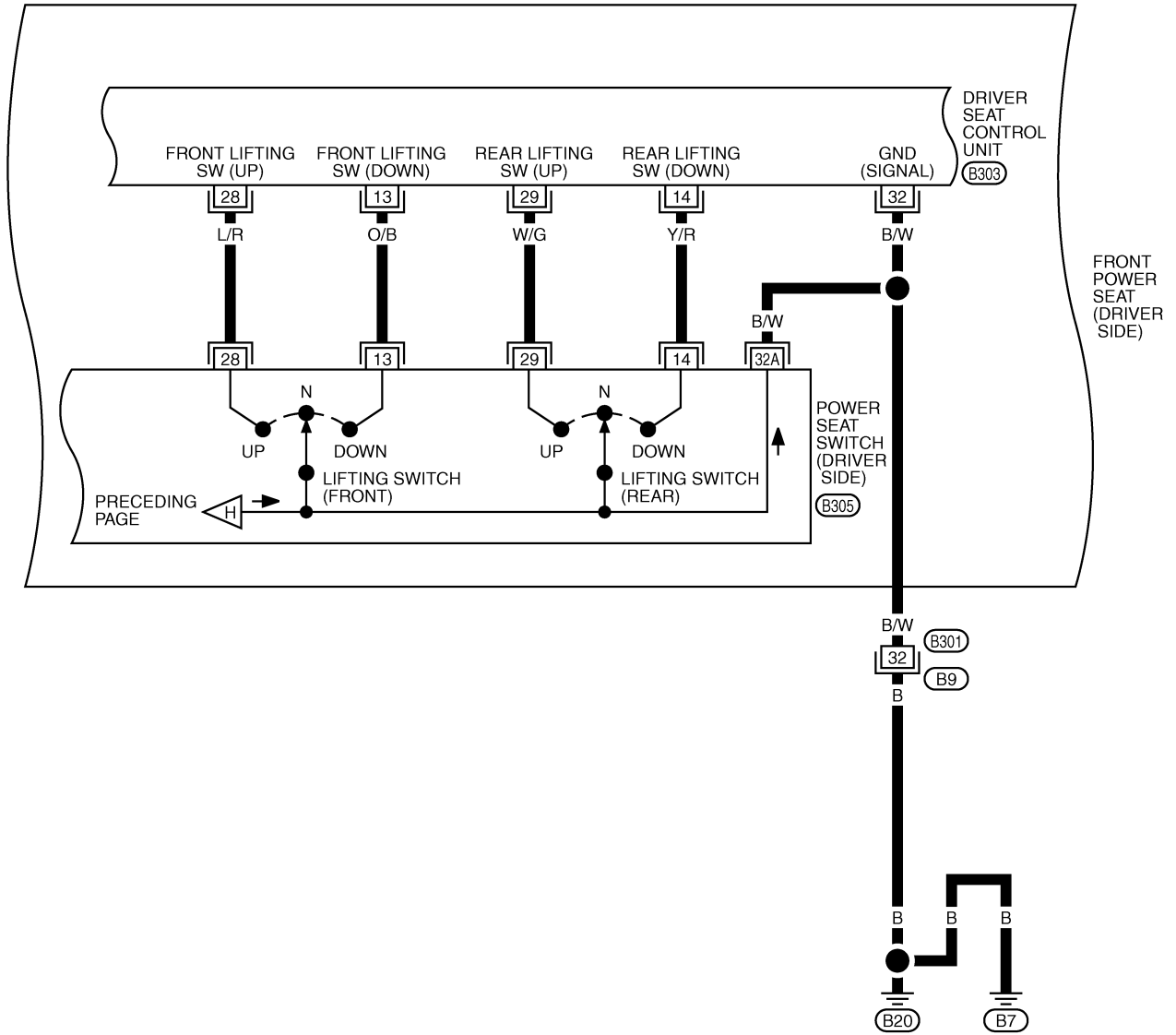

*: THIS CONNECTOR IS NOT SHOWN IN "HARNESS LAYOUT", PG SECTION.

TIWB0188E

AUTOMATIC DRIVE POSITIONER

SE-AUT/DP-07

A
B
C
D
E
F
G
H
J
K
L
M

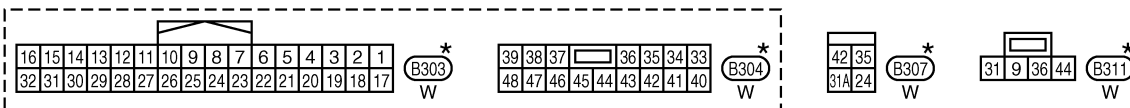
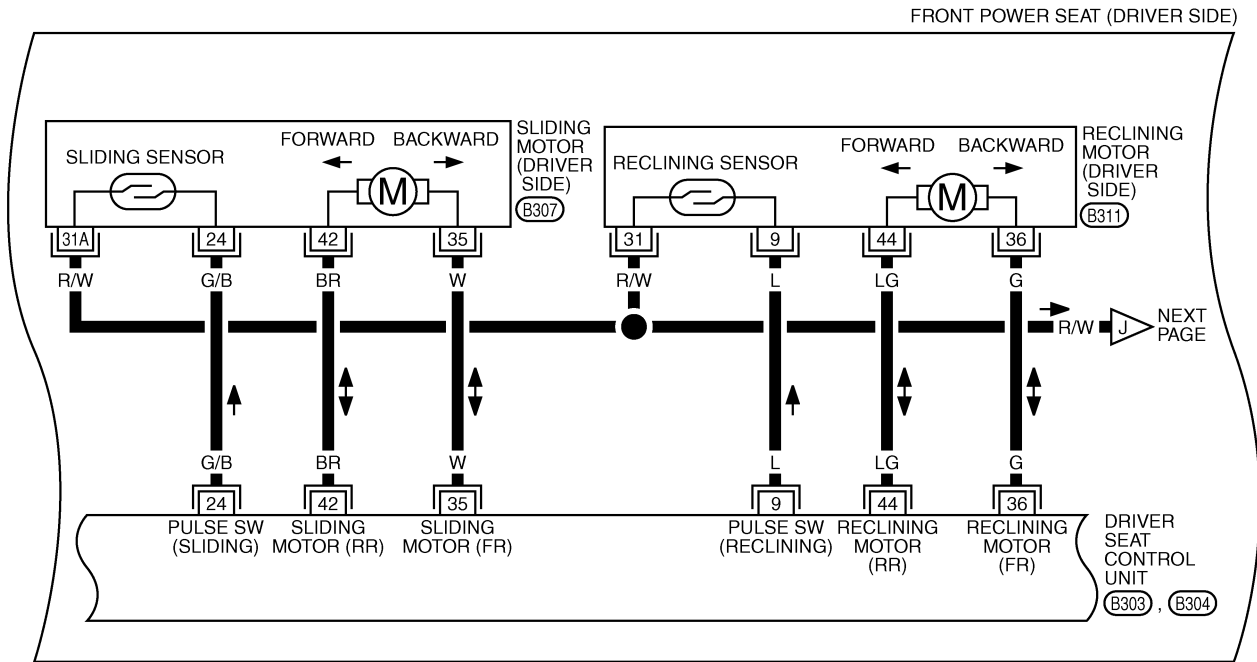

*: THIS CONNECTOR IS NOT SHOWN IN "HARNESS LAYOUT", PG SECTION.

TIWB0189E

AUTOMATIC DRIVE POSITIONER

SE-AUT/DP-08

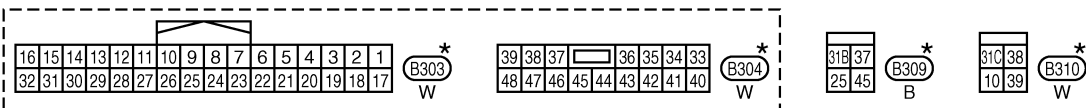
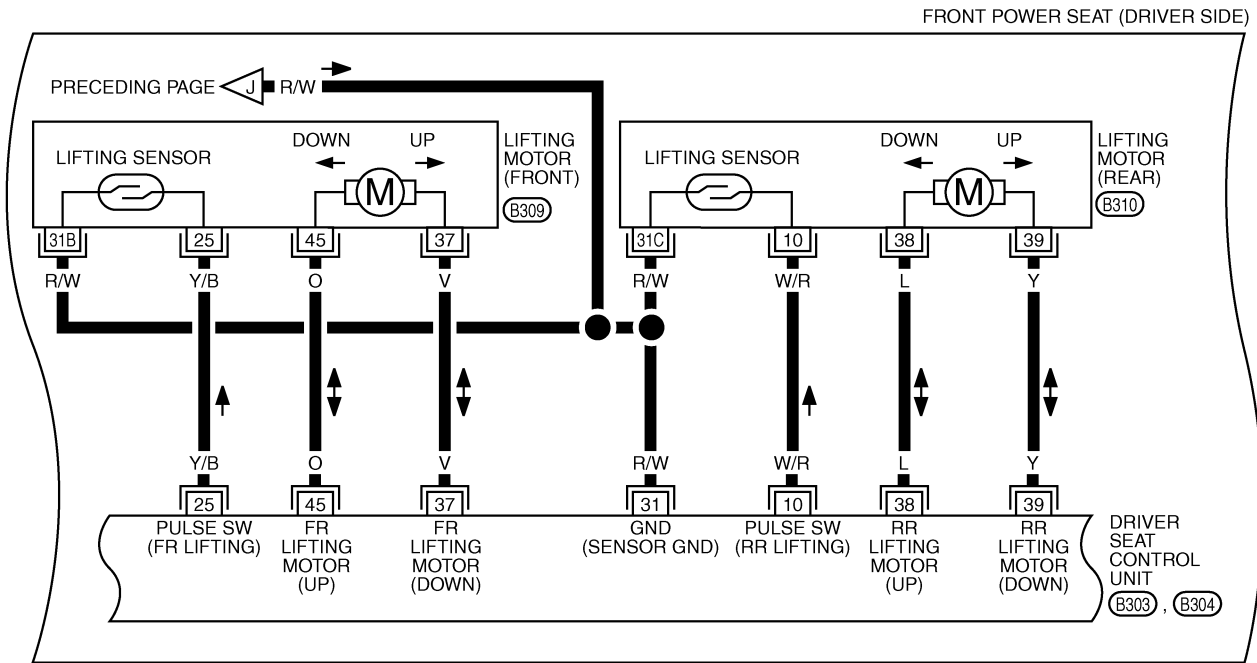

*: THIS CONNECTOR IS NOT SHOWN IN "HARNESS LAYOUT", PG SECTION.

TIWB0190E

AUTOMATIC DRIVE POSITIONER

SE-AUT/DP-09

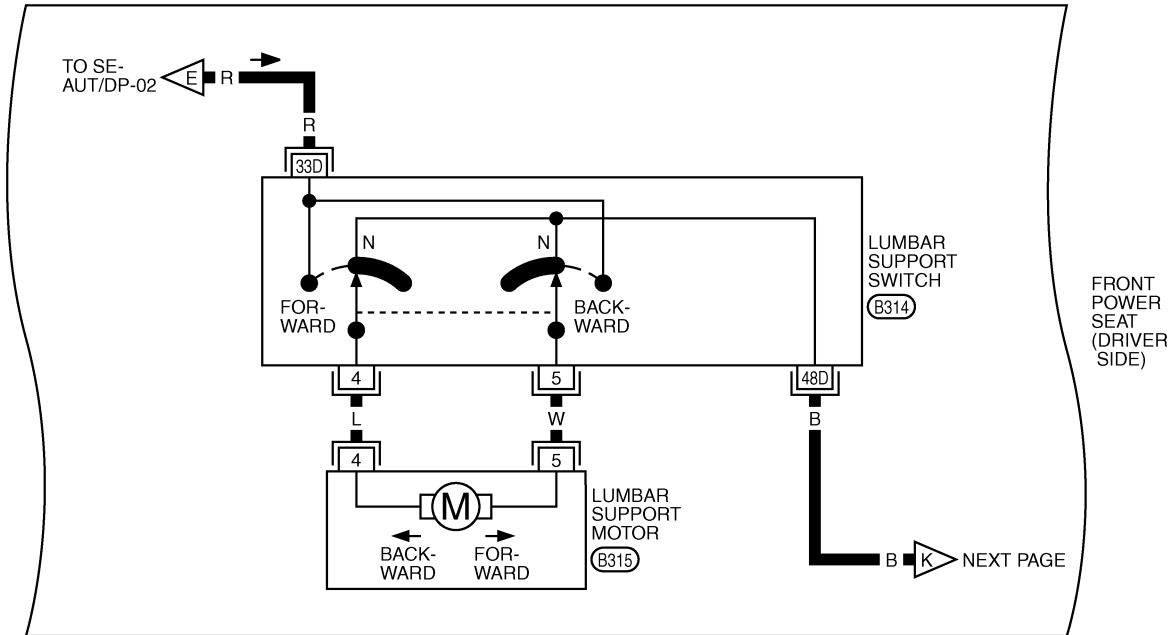

A
B
C
D
E
F
G
H
I
J
K
L
M

SE

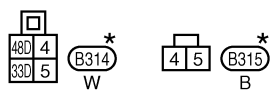

*: THIS CONNECTOR IS NOT SHOWN IN "HARNESS LAYOUT", PG SECTION.

TIWB0191E

AUTOMATIC DRIVE POSITIONER

SE-AUT/DP-10

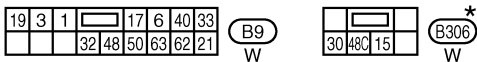
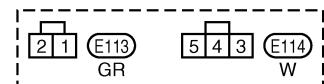
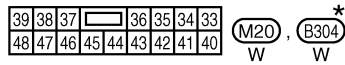
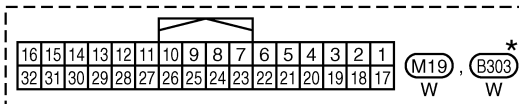
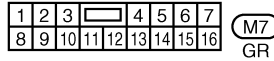
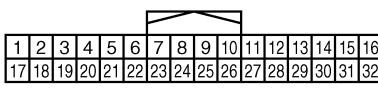
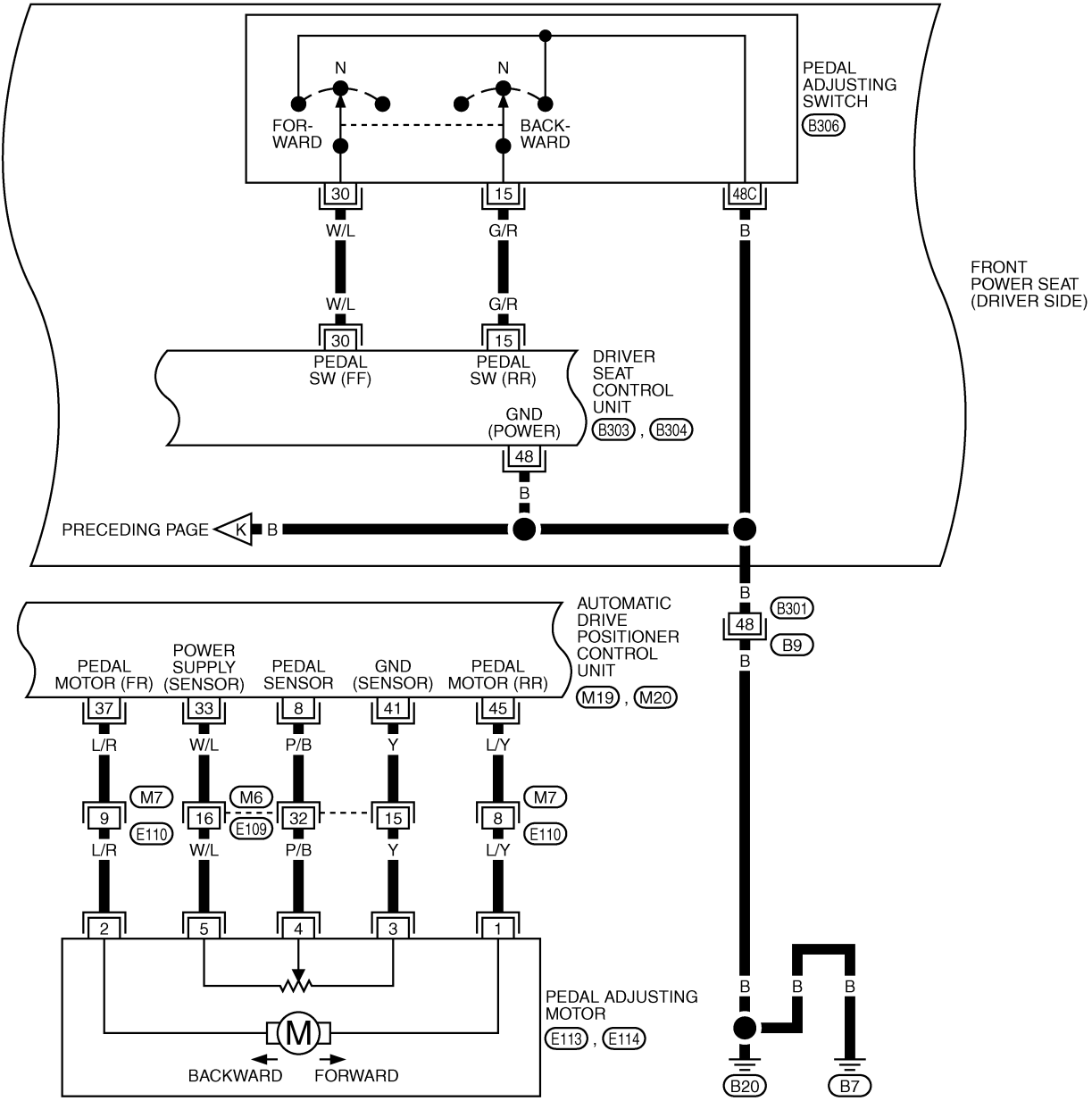

*: THIS CONNECTOR IS NOT SHOWN IN "HARNESS LAYOUT", PG SECTION.

TIWB0192E

AUTOMATIC DRIVE POSITIONER

SE-AUT/DP-11

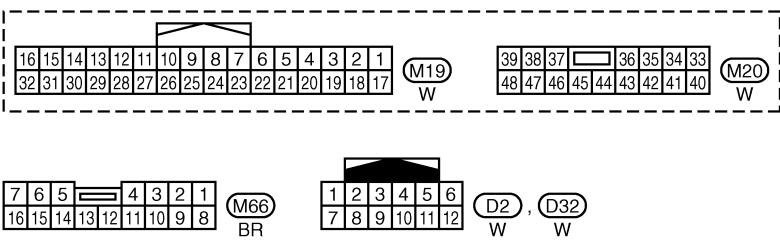
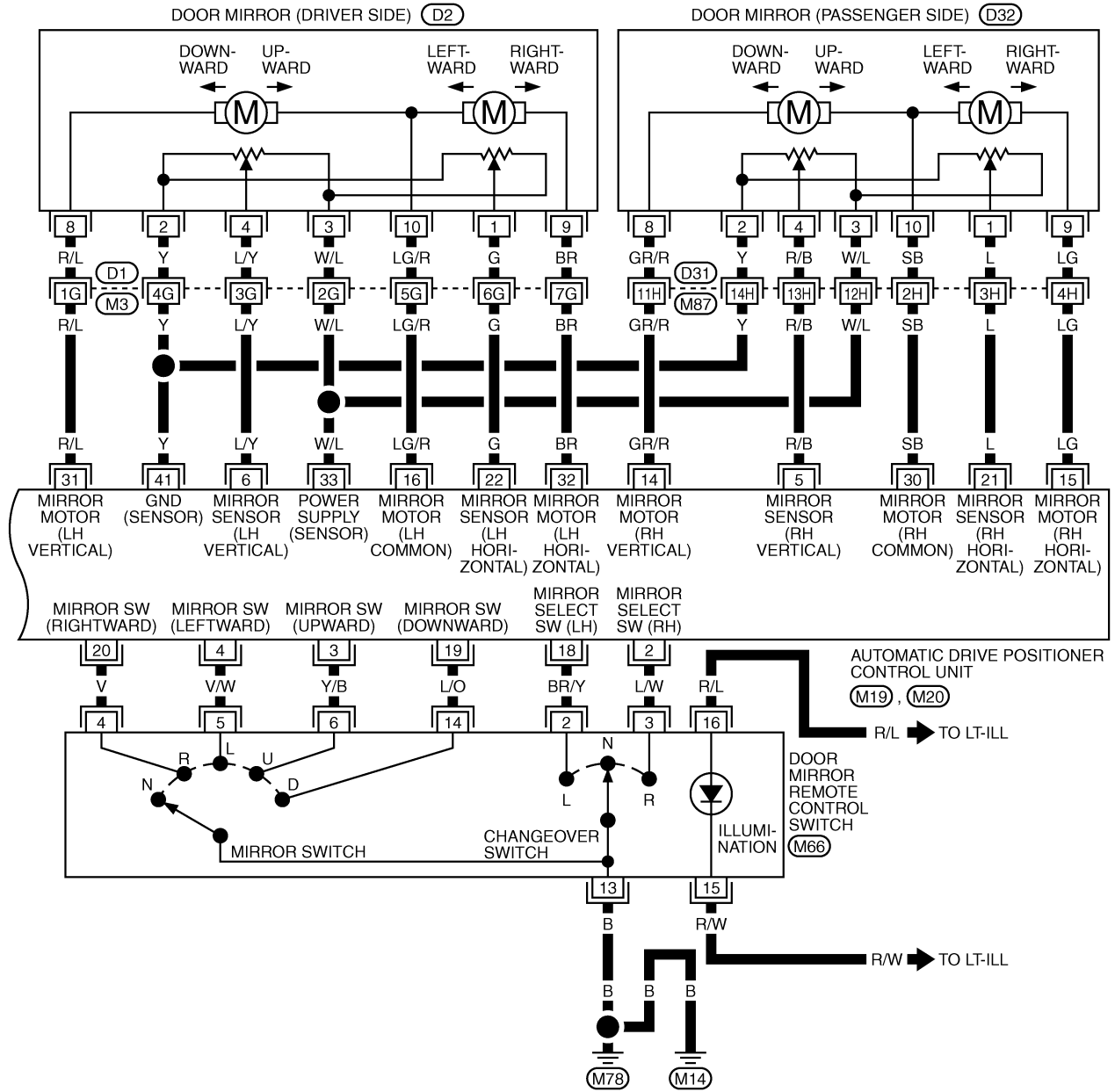

REFER TO THE FOLLOWING.
 (D1), (D31) -SUPER MULTIPLE JUNCTION (SMJ)

A
B
C
D
E
F
G
H
SE
J
K
L
M

AUTOMATIC DRIVE POSITIONER

SE-AUT/DP-12

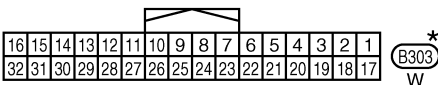
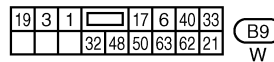
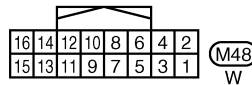
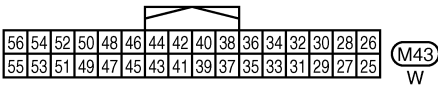
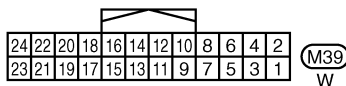
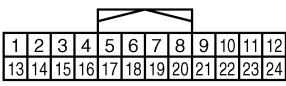
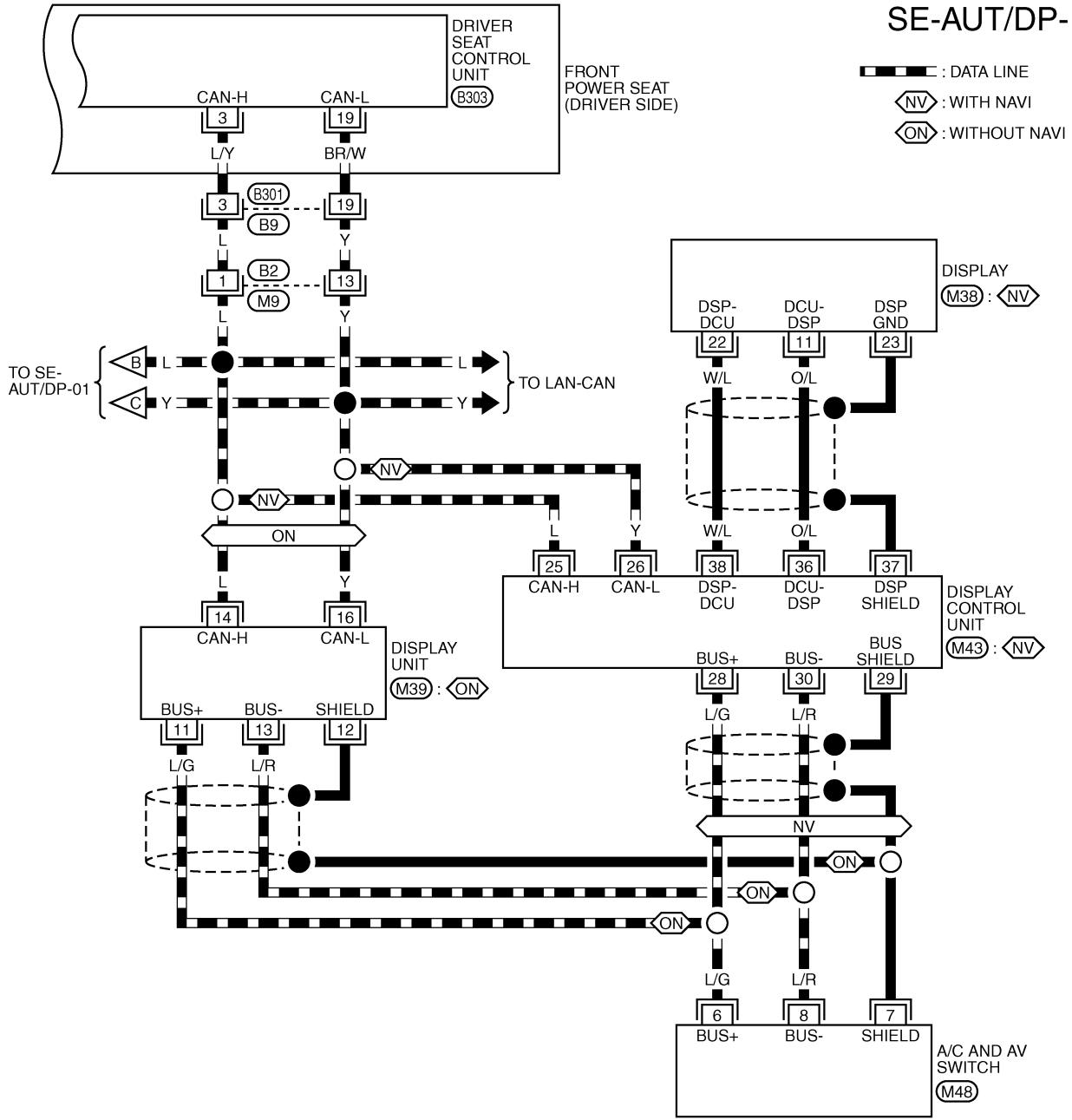

*: THIS CONNECTOR IS NOT SHOWN IN "HARNESS LAYOUT", PG SECTION.

TIWB0194E

AUTOMATIC DRIVE POSITIONER

Terminals and Reference Values for BCM

AIS003GI

TERMINAL	WIRE COLOR	ITEM	CONDITION	VOLTAGE (V) (Approx)
11	P/B	Ignition switch ACC power supply	Ignition switch (ACC or ON position)	Battery voltage
37	B/R	Key switch and key lock solenoid	Key switch ON (key is inserted in ignition key cylinder)	Battery voltage
			Key switch OFF (key is removed from ignition key cylinder)	0
38	R	Ignition switch ON power supply	Ignition switch (ON or START position)	Battery voltage
39	L	CAN-H	—	—
40	Y	CAN-L	—	—
42	GR	Power source (Fuse)	—	Battery voltage
52	B	Ground (Power)	—	0
55	W/B	Power source (Fusible link)	—	Battery voltage
62	SB	Drive side door switch	ON (Open) → OFF (Closed)	0 → Battery voltage

Terminals and Reference Values for Driver Seat Control Unit

AIS003GJ

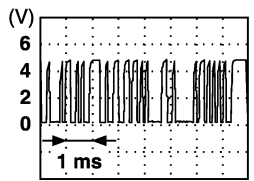
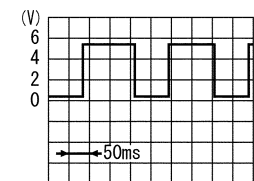
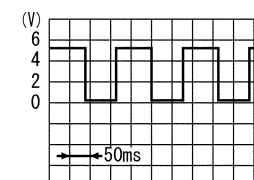
TERMINAL	WIRE COLOR	ITEM	CONDITION	VOLTAGE (V) (Approx)
1	Y/W	UART LINE (RX)	Pedal adjusting switch ON (FR or RR operation)	 <p style="text-align: right; font-size: small;">PIIA4813E</p>
3	L/Y	CAN-H	—	—
6	Y/G	Ignition switch START power supply	Ignition switch (START position)	Battery voltage
9	L	Reclining sensor signal	ON (seat reclining motor operation)	 <p style="text-align: right; font-size: small;">SIIA0692J</p>
			Other than above	0 or 5
10	W/R	Rear lifting sensor signal	ON (rear lifting motor operation)	 <p style="text-align: right; font-size: small;">SIIA0693J</p>
			Other than above	0 or 5
11	W/V	Sliding switch backward signal	ON (seat sliding switch backward operation)	0
			OFF	Battery voltage

AUTOMATIC DRIVE POSITIONER

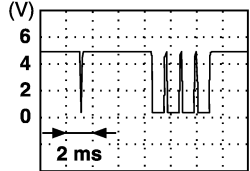
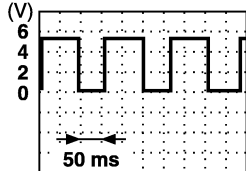
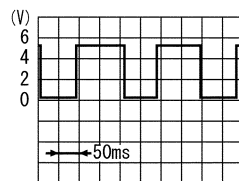
TERMINAL	WIRE COLOR	ITEM	CONDITION	VOLTAGE (V) (Approx)
12	G/Y	Reclining switch backward signal	ON (seat reclining switch backward operation)	0
			OFF	Battery voltage
13	O/B	Front lifting switch DOWN signal	ON (front lifting switch DOWN operation)	0
			OFF	Battery voltage
14	Y/R	Rear lifting switch DOWN signal	ON (rear lifting switch DOWN operation)	0
			OFF	Battery voltage
15	G/R	Pedal adjusting switch backward signal	ON (pedal adjusting switch backward operation)	0
			OFF	Battery voltage
17	Y/L	UART LINE (TX)	Pedal adjusting switch ON (FR or RR operation)	<div style="text-align: center;">  <p>PIIA4814E</p> </div>
19	BR/W	CAN-L	—	—
21	R/L	Detention switch signal	Selector lever P position With ignition key in ignition key cylinder	0
			Selector lever other than P position With ignition key in ignition key cylinder	Battery voltage
24	G/B	Seat sliding sensor signal	ON (seat sliding motor operation)	<div style="text-align: center;">  <p>PIIA3277E</p> </div>
			Other than above	0 or 5
25	Y/B	Front lifting sensor signal	ON (front lifting motor operation)	<div style="text-align: center;">  <p>SIIA0691J</p> </div>
			Other than above	0 or 5
26	G/W	Seat sliding switch forward signal	ON (seat sliding switch forward operation)	0
			OFF	Battery voltage
27	L/W	Seat reclining switch forward signal	ON (seat reclining switch forward operation)	0
			OFF	Battery voltage

AUTOMATIC DRIVE POSITIONER

TERMINAL	WIRE COLOR	ITEM	CONDITION	VOLTAGE (V) (Approx)	
28	L/R	Front lifting switch UP signal	ON (front lifting switch UP operation)	0	A
			OFF	Battery voltage	B
29	W/G	Rear lifting switch UP signal	ON (rear lifting switch UP operation)	0	C
			OFF	Battery voltage	C
30	W/L	Pedal adjusting switch forward signal	ON (pedal adjusting switch forward operation)	0	D
			OFF	Battery voltage	D
31	R/W	Sensor ground	—	0	E
32	B/W	Ground (Signal)	—	0	E
33	R	Power source (Fucible link)	—	Battery voltage	
35	W	Sliding motor forward output signal	Sliding switch forward operation (Motor operated)	Battery voltage	F
			OFF	0	
36	G	Reclining motor forward output signal	Reclining switch forward operation (Motor operated)	Battery voltage	G
			OFF	0	
37	V	Front lifting motor DOWN output signal	Front lifting switch down operation (Motor operated)	Battery voltage	H
			OFF	0	
38	L	Rear lifting motor UP output signal	Rear end lifting switch up operation (Motor operated)	Battery voltage	SE
			OFF	0	
39	Y	Rear lifting motor DOWN output signal	Rear end lifting switch down operation (Motor operated)	Battery voltage	J
			OFF	0	
40	W/B	Power source (Fuse)	—	Battery voltage	K
42	BR	Sliding motor backward output signal	Sliding switch backward operation (Motor operated)	Battery voltage	L
			OFF	0	
44	LG	Reclining motor backward output signal	Reclining switch backward operation (Motor operated)	Battery voltage	M
			OFF	0	
45	O	Front lifting motor UP output signal	Front lifting switch upward operation (Motor operated)	Battery voltage	
			OFF	0	
48	B	Ground (Power)	—	0	

AUTOMATIC DRIVE POSITIONER

Terminals and Reference Values for Automatic Driver Positioner Control Unit

AIS003GK

TERMINAL	WIRE COLOR	ITEM	CONDITION	VOLTAGE (V) (Approx)
2	L/W	Changeover switch RH signal	When changeover switch in RH position	0
			When changeover switch in neutral position	5
3	Y/B	Mirror switch UP signal	When mirror switch in UP position	0
			When mirror switch in neutral position	5
4	V/W	Mirror switch LEFT signal	When mirror switch in LEFT position	0
			When mirror switch in neutral position	5
5	R/B	Mirror sensor (RH vertical) signal	When mirror motor RH is UP or DOWN operation	Changes between 3.4 (close to perk) 0.6 (close to valley)
6	L/Y	Mirror sensor (LH vertical) signal	When mirror motor LH is UP or DOWN operation	Changes between 3.4 (close to perk) 0.6 (close to valley)
8	P/B	Pedal sensor input signal	Pedal position front end	0.5
			Pedal position rear end	4.5
9	LG/B	Power seat memory switch 1 signal	Memory switch 1 ON	0
			Memory switch 1 OFF	5
10	R	UART LINE (TX)	Pedal adjusting switch ON (FR or RR operation)	 <p style="text-align: right; font-size: small;">PIIA4813E</p>
12	GR/L	Power seat memory switch inductor 1 signal	Memory switch 1 ON	1
			Memory switch 1 OFF	Battery voltage
13	Y/G	Power seat memory switch inductor 2 signal	Memory switch 2 ON	1
			Memory switch 2 OFF	Battery voltage
14	GR/R	Mirror motor RH UP signal	When mirror motor RH UP operation	1.5 - Battery voltage
			Mirror motor RH OFF	0
15	LG	Mirror motor RH LEFT signal	When mirror motor RH LEFT operation	1.5 - Battery voltage
			Mirror motor RH OFF	0
16	LG/R	Mirror motor LH DOWN signal	When mirror motor LH DOWN operation	1.5 - Battery voltage
			Mirror motor LH OFF	0
		Mirror motor LH RIGHT signal	When mirror motor LH RIGHT operation	1.5 - Battery voltage
			Mirror motor LH OFF	0
18	BR/Y	Changeover switch LH signal	When changeover switch in LH position	0
			When changeover switch in neutral position	5

AUTOMATIC DRIVE POSITIONER

TERMINAL	WIRE COLOR	ITEM	CONDITION	VOLTAGE (V) (Approx)
19	L/O	Mirror switch DOWN signal	When mirror switch in DOWN position	0
			When mirror switch in neutral position	5
20	V	Mirror switch RIGHT signal	When mirror switch in RIGHT position	0
			When mirror switch in neutral position	5
21	L	Mirror sensor (RH horizontal) signal	When mirror motor RH is LEFT or RIGHT operation	Changes between 3.4 (close to left edge) 0.6 (close to right edge)
22	G	Mirror sensor (LH horizontal) signal	When mirror motor LH is LEFT or RIGHT operation	Changes between 3.4 (close to left edge) 0.6 (close to right edge)
24	R/Y	Power seat set switch signal	Set switch 1 ON	0
			Set switch 1 OFF	5
25	P/L	Power seat memory switch 2 signal	Memory switch 2 ON	0
			Memory switch 2 OFF	5
26	R/G	UART LINE (RX)	Pedal adjusting switch ON (FR or RR operation)	<p style="text-align: right; font-size: small;">P1IA4814E</p>
30	SB	Mirror motor RH DOWN signal	When mirror motor RH DOWN operation	1.5 - Battery voltage
			Mirror motor RH OFF	0
		Mirror motor RH RIGTH signal	When mirror motor RH RIGHT operation	1.5 - Battery voltage
			Mirror motor RH OFF	0
31	R/L	Mirror motor LH UP signal	When mirror motor LH UP operation	1.5 - Battery voltage
			Mirror motor LH OFF	0
32	BR	Mirror motor LH LEFT signal	When mirror motor LH LEFT operation	1.5 - Battery voltage
			Mirror motor LH OFF	0
33	W/L	Sensor power supply	—	5
34	Y/R	Power source (Fuse)	—	Battery voltage
37	L/R	Pedal adjust motor forward signal	Pedal adjust motor forward operation (Motor operated)	Battery voltage
			OFF	0
39	W/R	Power source (Fusible link)	—	Battery voltage
40	B	Ground (Signal)	—	0
41	Y	Sensor ground	—	0
45	L/Y	Pedal adjust motor RR signal	Pedal adjust motor backward operation (Motor operated)	Battery voltage
			OFF	0
48	B	Ground (Power)	—	0

A
B
C
D
E
F
G
H
SE
J
K
L
M

AUTOMATIC DRIVE POSITIONER

AIS003GL

Work Flow

1. Check the symptom and customer's requests.
2. Understand the system description. Refer to [SE-12, "System Description"](#) .
3. Perform the preliminary check, refer to [SE-38, "Preliminary Check"](#) .
4. Check the self-diagnosis, results using CONSULT-II refer to [SE-42, "CONSULT-II Function \(AUTO DRIVE POS.\)"](#) .
5. Repair or replace depending on the self-diagnostic results.
6. Based on the trouble diagnosis chart, repair or replace the cause of the malfunction. Refer to [SE-46, "Symptom Chart"](#) .
7. Does the automatic drive positioned system operate normally?
If it is normal, GO TO 8.
If it is not normal, GO TO 3.
8. INSPECTION END

Preliminary Check SETTING CHANGE FUNCTION

AIS003GM

The settings of the automatic driving position system can be changed, using CONSULT-II and the display in the center of the instrument panel.

×: Applicable –: Not applicable

Setting item	Content	CONSULT-II (WORK SUPPORT)	Display unit	Default setting	Factory setting
SEAT SLIDE VOLUME SET	The distance at exiting operation can be selected from the following 3 modes.	40mm	—	×	×
		80mm		—	—
		150mm		—	—
Sliding Driver Seat When Entry/ Exiting Vehicle	The seat sliding turnout and return at entry/exit can be selected: ON (operated)–OFF (not operated)	ON	ON: Indicator lamp ON	—	×
		OFF	OFF: Indicator lamp OFF	×	—
Reset custom settings*	All settings to default.	—	Default: Setting button ON	—	—

It is possible to set sliding driver seat for entry/exit of vehicle by pressing set switch.

Content	Setting change operation	Indicator LEDs
The seat sliding turnout and return at entry/exit can be operated.	Press the set switch for than 10 seconds	Blinking twice
The seat sliding turnout and return at entry/exit can be not operated.		Blinking once

*: Setting of sliding driver seat for entry/exit of vehicle is ON at factory-shipment. But if custom settings are reset, setting turns OFF.

NOTE:

After the setting is registered, the new setting is effective, even if the battery is disconnected.

AUTOMATIC DRIVE POSITIONER

POWER SUPPLY AND GROUND CIRCUIT CHECK

1. CHECK FUSE

Check if any of the following fuses in the BCM are blown.

Unit	Power source	Fuse No.
BCM	Battery power supply	F (50A)
		18(10A)
	Ignition switch ON or STRAT signal	1 (10A)
	Ignition switch ACC or ON signal	6 (10A)

NOTE:

Refer to [SE-17. "Component Parts And Harness Connector Location"](#) .

OK or NG

OK >> GO TO 2.

NG >> If fuse is blown, be sure to eliminate cause of malfunction before installing new fuse. Refer to [PG-3. "POWER SUPPLY ROUTING CIRCUIT"](#) .

2. CHECK POWER SUPPLY CIRCUIT (BCM)

1. Turn ignition switch OFF.
2. Disconnect BCM connector.
3. Check voltage between BCM connector and ground.

Connector	Terminals (Wire color)		Power source	Condition	Voltage (V) (Approx)
	(+)	(-)			
M34	11 (P/B)	Ground	ACC power supply	Ignition switch ACC	Battery voltage
	38 (R)		Ignition power supply	Ignition switch ON	
M35	42 (GR), 55 (W/B)		Battery power supply	Ignition switch OFF	

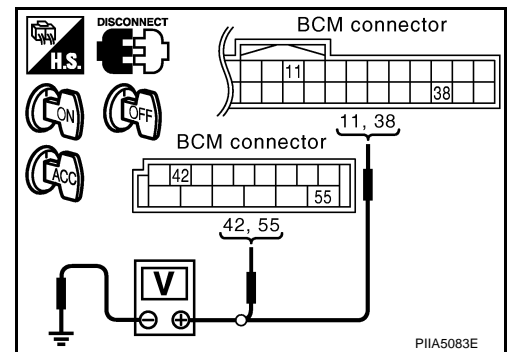

OK or NG

OK >> GO TO 3.

NG >> Repair or replace the harness between BCM and fuse.

3. CHECK GROUND CIRCUIT (BCM)

Check continuity between BCM connector M35 terminal 52 (B) and ground.

52 (B) – Ground : Continuity should exist.

OK or NG

OK >> BCM circuit is OK. Check the driver seat control unit. GO TO 4.

NG >> Repair or replace the harness between BCM and ground.

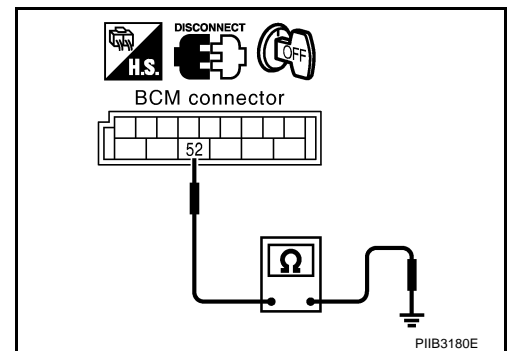

AUTOMATIC DRIVE POSITIONER

4. CHECK FUSE

Make sure any of the following fuse in the driver seat control unit and automatic drive positioner control unit are blown.

Unit	Power source	Fuse No.
Driver seat control unit	Ignition switch START signal	9 (10A)
	Battery power supply	21 (10A)

NOTE:

Refer to [SE-17, "Component Parts And Harness Connector Location"](#) .

OK or NG

OK >> GO TO 5.

NG >> If fuse is blown, be sure to eliminate cause of malfunction before installing new fuse. Refer to [PG-3, "POWER SUPPLY ROUTING CIRCUIT"](#) .

5. CHECK POWER SUPPLY CIRCUIT (DRIVER SEAT CONTROL UNIT)

1. Disconnect driver seat control unit connector.
2. Check voltage between driver seat control unit connector and ground.

Connector	Terminals (Wire color)		Power source	condition	Voltage (V) (Approx)
	(+)	(-)			
B303	33 (R), 40 (W/B)	Ground	Battery power supply	Ignition switch OFF	Battery voltage
	6 (Y/G)		START power supply	Ignition switch START	

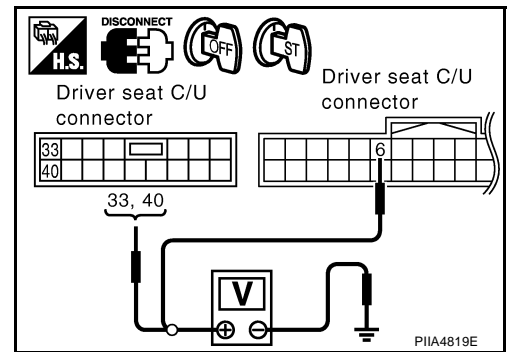

OK or NG

OK >> GO TO 6.

NG >> Repair or replace harness between driver seat control unit and fuse block (J/B).

6. CHECK GROUND CIRCUIT (DRIVER SEAT CONTROL UNIT)

1. Turn ignition switch OFF.
2. Check continuity between the driver seat control unit connector B303 terminal 32 (B/W), 48 (B) and ground.

32 (B/W) – Ground : Continuity should exist.

48 (B) – Ground : Continuity should exist.

OK or NG

OK >> Driver seat control unit circuit check is OK, GO TO 7.

NG >> Repair or replace harness between driver seat control unit and ground.

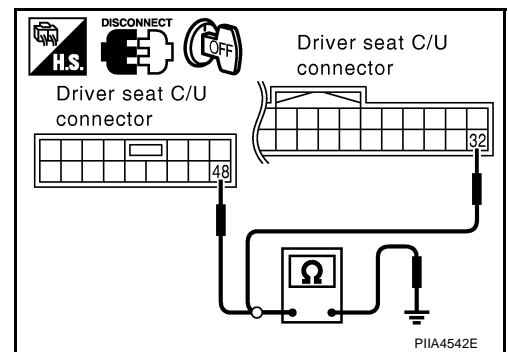

AUTOMATIC DRIVE POSITIONER

7. CHECK POWER SUPPLY CIRCUIT (AUTOMATIC DRIVE POSITIONER CONTROL UNIT)

1. Disconnect automatic drive positioner control unit connector.
2. Check voltage between automatic drive positioner control unit connector M20 terminal 34 (Y/R), 39 (W/R) and ground.

34 (Y/R) – Ground : Battery voltage
39 (W/R) – Ground : Battery voltage

OK or NG

- OK >> GO TO 8.
NG >> Repair or replace harness between driver seat control unit and fuse block (J/B).

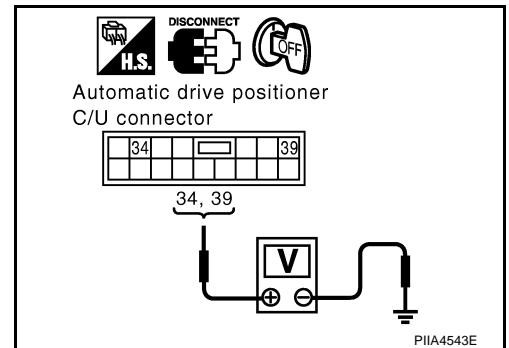

8. CHECK GROUND CIRCUIT (AUTOMATIC DRIVE POSITIONER CONTROL UNIT)

Check continuity between the automatic drive positioner control unit connector M20 terminal 40 (B), 48 (B) and ground.

40 (B) – Ground : Continuity should exist.
48 (B) – Ground : Continuity should exist.

OK or NG

- OK >> Automatic drive positioner control unit circuit is OK.
NG >> Repair or replace harness between automatic drive positioner control unit and ground.

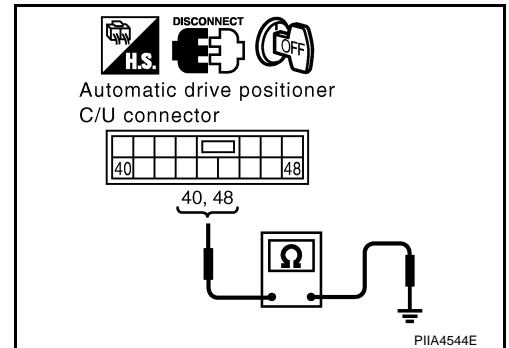

AUTOMATIC DRIVE POSITIONER

AIS003GN

CONSULT-II Function (AUTO DRIVE POS.)

CONSULT-II can display each diagnostic item using the diagnostic test modes shown following.

CONSULT-II diagnosis items	Inspection item, self-diagnosis mode		Content	Reference page
AUTO DRIVE POSITIONER	WORK SUPPORT*1		Changes the setting for each function.	SE-38
	SELF-DIG RESULTS		Check the self-diagnosis results.	SE-44
	DATA MONITOR	Selection from menu	Displays the input data to driver seat control unit driver seat control unit and automatic driving positioned control unit on real-time basis.	SE-45
	CAN DIAGNOSTIC SUPPORT MONITOR		The results of transmit / receive diagnosis of CAN communication can be read	LAN-19
	ACTIVE TEST		Gives a drive signal to a load to check the operation.	SE-46
	DRIVER SEAT CONTROL UNIT PART NUMBER		Displays driver seat control unit part No.	—
BCM	DATA MONITOR	Selection from menu	Displays the input data to BCM on real-time basis	BL-41

*1: For setting seat functions only.

CONSULT-II INSPECTION PROCEDURE

CAUTION:

If CONSULT-II is used with no connection of CONSULT-II CONVERTER, malfunctions might be detected in self-diagnosis depending on control unit which carry out CAN communication.

1. Turn ignition switch "OFF".
2. Connect "CONSULT-II" and "CONSULT-II CONVERTER" to the data link connector.

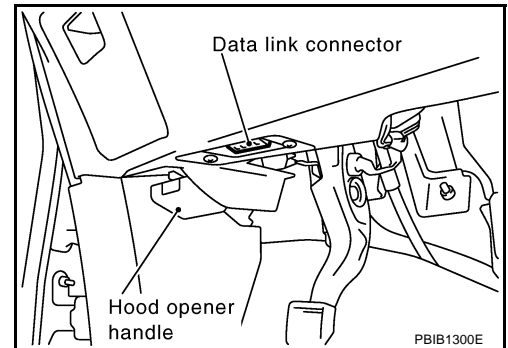

3. Turn ignition switch "ON".
4. Touch "START (NISSAN BASED VHCL)".

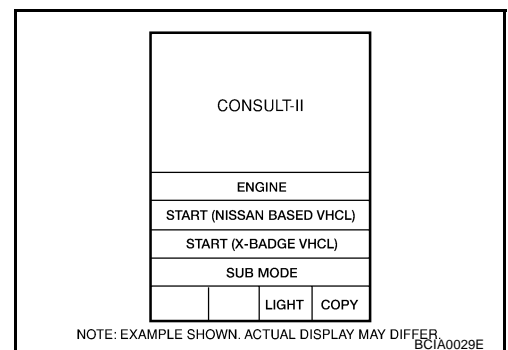

AUTOMATIC DRIVE POSITIONER

5. Touch "AUTO DRIVE POS" and "BCM".
If "AUTO DRIVE POS." and "BCM" are not indicated, refer to [GI-39, "CONSULT-II Data Link Connector \(DLC\) Circuit"](#).

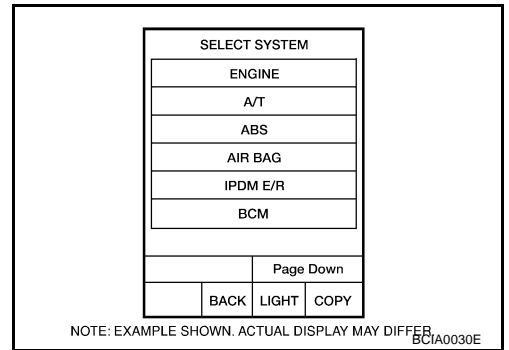

6. Select diagnosis mode.
"DATA MONITOR", "ACTIVE TEST", "SELF-DIAG RESULTS", "ECU PART NUMBER" and "WORK SUPPORT" are available.

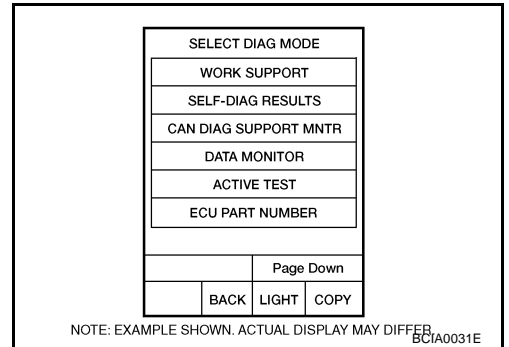

A
B
C
D
E
F
G
H
J
K
L
M

SE

AUTOMATIC DRIVE POSITIONER

SELF-DIAGNOSIS RESULTS

DISPLAY ITEM LIST

CONSULT-II display	Item	Malfunction is detected when...	Reference page
CAN COMM CIRC [U1000]	CAN communication	Malfunction is detected in CAN communication.	SE-46
SEAT SLIDE [B2112]	Seat slide motor	When any manual and automatic operations are not performed, if any motor operations of seat slide is detected for 0.1 second or more, status is judged "Output error".	SE-48 SE-60
SEAT RECLINING [B2113]	Seat reclining motor	When any manual and automatic operations are not performed, if any motor operations of seat reclining is detected for 0.1 second or more, status is judged "Output error".	SE-49 SE-61
SEAT LIFTER FR [B2114]	Seat lifting FR motor	When any manual and automatic operations are not performed, if any motor operations of seat lifting FR is detected for 0.1 second or more, status is judged "Output error".	SE-52 SE-62
SEAT LIFTER RR [B2115]	Seat lifting RR motor	When any manual and automatic operations are not performed, if any motor operations of seat lifting RR is detected for 0.1 second or more, status is judged "Output error".	SE-53 SE-63
ADJ PEDAL MOTOR [B2117]	Pedal adjust motor	When any manual and automatic operations are not performed, if motor operations of seat pedal is detected for 0.1 second or more, status is judged "Output error".	SE-54 SE-64
ADJ PEDAL SENSOR [B2120]	Pedal adjust sensor	When pedal adjust sensor detects 0.5V or lower, or 4.5V or higher, for 0.5 seconds or more.	SE-64
DETENT SW [B2126]	Detente SW	With the CVT selector lever in P position (Detente switch OFF), if the vehicle speed of 7 km/h (4 MPH) or higher was input the detente switch input system is judged malfunctioning.	SE-84
UART COMM [B2128]	UART communication	Malfunction is detected in UART communication.	SE-90

NOTE:

- If detection switch error is detected, manual adjustable pedal operation cannot be performed when ignition switch turns ON.
 - The displays of CAN communication and detection switch display error detecting condition from memory erase to the present on "TIME".
 - If error is detected in the past and present error is detected, "CRNT" is displayed.
 - If error is detected in the past and present error is not detected, "PAST" is displayed.
 - If error has never been detected, nothing is displayed on "TIME".
 - Any items other than CAN communication and detection switch count error detection frequency occurred after erase history to "1-127".
 - If error was detected in the past, error detection frequency from memory erase to the present is displayed on "TIME".
 - If error has never been detected, nothing is displayed on "TIME".
 - Can clear the detected memory.
- Normal: Clear memory in normal condition, history is erased and nothing is displayed on "TIME".
 Error: Clear memory in error condition, error is detected again and "1" is displayed on "TIME".

AUTOMATIC DRIVE POSITIONER

DATA MONITOR SELECTION FROM MEMU

Monitor item [OPERATION or UNIT]	Contents
SLIDE SW-FR	"ON/OFF" ON/OFF status judged from the sliding switch (FR) signal is displayed.
SLIDE SW-RR	"ON/OFF" ON/OFF status judged from the sliding switch (RR) signal is displayed.
RECLN SW-FR	"ON/OFF" ON/OFF status judged from the reclining switch (FR) signal is displayed.
RECLN SW-RR	"ON/OFF" ON/OFF status judged from the reclining switch (RR) signal is displayed.
LIFT FR SW-UP	"ON/OFF" ON/OFF status judged from the FR lifter switch (UP) signal is displayed.
LIFT FR SW-DN	"ON/OFF" ON/OFF status judged from the FR lifter switch (DOWN) signal is displayed.
LIFT RR SW-UP	"ON/OFF" ON/OFF status judged from the RR lifter switch (UP) signal is displayed.
LIFT RR SW-DN	"ON/OFF" ON/OFF status judged from the RR lifter switch (DOWN) signal is displayed.
MIR CON SW-UP	"ON/OFF" ON/OFF status judged from the door mirror remote control switch (UP) signal is displayed.
MIR CON SW-DN	"ON/OFF" ON/OFF status judged from the door mirror remote control switch (DOWN) signal is displayed.
MIR CON SW-RH	"ON/OFF" ON/OFF status judged from the door mirror remote control switch (RIGHT) signal is displayed.
MIR CON SW-LH	"ON/OFF" ON/OFF status judged from the door mirror remote control switch (LEFT) signal is displayed.
MIR CHNG SW-R	"ON/OFF" ON/OFF status judged from the door mirror remote control switch (switching to RIGHT) signal is displayed.
MIR CHNG SW-L	"ON/OFF" ON/OFF status judged from the door mirror remote control switch (switching to LEFT) signal is displayed.
SET SW	"ON/OFF" ON/OFF status judged from the setting switch signal is displayed.
PEDAL SW-FR	"ON/OFF" ON/OFF status judged from the pedal adjusting switch (FR) signal is displayed.
PEDAL SW-RR	"ON/OFF" ON/OFF status judged from the pedal adjusting switch (RR) signal is displayed.
MEMORY SW1	"ON/OFF" ON/OFF status judged from the seat memory switch 1 signal is displayed.
MEMORY SW2	"ON/OFF" ON/OFF status judged from the seat memory switch 2 signal is displayed.
DETENT SW	"ON/OFF" The selector lever position "OFF (P position) / ON (other than P position)" judged from the detention switch signal is displayed.
STARTER SW	"ON/OFF" Ignition key switch ON (START, ON) /OFF (ignition switch IGN, ACC, or OFF) status judged from the ignition switch signal is displayed.
SLIDE PULSE	— Value (32768) when battery connects is as standard. If it moves backward, the value increases. If it moves forward, the value decreases.
RECLN PULSE	— Value (32768) when battery connects is as standard. If it moves backward, the value increases. If it moves forward, the value decreases.
LIFT FR PULSE	— Value (32768) when battery connects is as standard. If it moves DOWN, the value increases. If it moves UP, the value decreases.
LIFT RR PULSE	— Value (32768) when battery connects is as standard. If it moves DOWN, the value increases. If it moves UP, the value decreases.
MIR/SEN RH R-L	"V" Voltage output from RH door mirror sensor (LH/RH) is displayed.
MIR/SEN RH U-D	"V" Voltage output from RH door mirror sensor (UP/DOWN) is displayed.
MIR/SEN LH R-L	"V" Voltage output from LH door mirror sensor (LH/RH) is displayed.
MIR/SEN LH U-D	"V" Voltage output from LH door mirror sensor (UP/DOWN) is displayed.
PEDAL SEN	"V" The pedal position (voltage) judged from the pedal adjust sensor signal is displayed.

A
B
C
D
E
F
G
H
SE
J
K
L
M

AUTOMATIC DRIVE POSITIONER

ACTIVE TEST

CAUTION:

During vehicle driving, do not perform active test.

NOTE:

If active test is performed, reset seat memory and key fob interlock drive positioner after performing work.

DISPLAY ITEM LIST

Test item	Description
SEAT SLIDE	The sliding motor is activated by receiving the drive signal.
SEAT RECLINING	The reclining motor is activated by receiving the drive signal.
SEAT LIFTER FR	The front end lifter motor is activated by receiving the drive signal.
SEAT LIFTER RR	The rear end lifter motor is activated by receiving the drive signal.
PEDAL MOTOR	The pedal adjust motor is activated by receiving the drive signal.
MEMORY SW INDCTR	The memory switch indicator is lit by receiving the drive signal.
MIRROR MOTOR RH	The RH mirror motor moves the mirror UP/DOWN and LEFT/RIGHT by receiving the drive signal.
MIRROR MOTOR LH	The LH mirror motor moves the mirror UP/DOWN and LEFT/RIGHT by receiving the drive signal.

Check CAN Communication System Inspection

AIS003KM

1. CHECK SELF-DIAGNOSTIC RESULT

CAUTION:

If CONSULT-II is used with no connection of CONSULT-II CONVERTER, malfunctions might be detected in self-diagnosis depending on control unit which carry out CAN communication.

With CONSULT-II

1. Connect CONSULT-II, and turn ignition switch ON.
2. Touch "AUTO DRIVE POS." on "SELECT SYSTEM" screen.
3. Touch "SELF-DIAG RESULTS" on "SELECT DIAG MODE" screen.
4. Check display content in self-diagnostic results.

Displayed U1000?

- Yes >> GO TO [LAN-5, "Precautions When Using CONSULT-II"](#) .
 No >> Inspection END.

Symptom Chart

AIS003GP

Symptom	Diagnoses / service procedure	Refer to page			
Only setting change function cannot be set with display.	1. Preliminary check	SE-38			
	2. CAN communication inspection using CONSULT-II (self-diagnosis)	SE-46			
	3. If the above system are normal, check display system	<table border="1"> <tr> <td>Interacted display system (with out NAVI)</td> <td>AV-74</td> </tr> <tr> <td>Navigation system (with NAVI)</td> <td>AV-104</td> </tr> </table>	Interacted display system (with out NAVI)	AV-74	Navigation system (with NAVI)
Interacted display system (with out NAVI)	AV-74				
Navigation system (with NAVI)	AV-104				
A part of seat system does not operate (both automatically and manually).	1. Sliding motor circuit check	SE-48			
	2. Reclining motor circuit check	SE-49			
	3. Front lifting motor circuit check	SE-52			
	4. Rear lifting motor circuit check	SE-53			
	5. If the above systems are normal, replace the driver seat control unit	SE-17			

AUTOMATIC DRIVE POSITIONER

Symptom	Diagnoses / service procedure	Refer to page	
A part of pedal adjust and door mirror does not operate (both automatically and manually).	1. Pedal adjusting motor circuit check	SE-54	A
	2. Mirror motor LH circuit check	SE-56	B
	3. Mirror motor RH circuit check	SE-58	C
	4. If the above systems are normal, replace the automatic drive positioner control unit.	SE-17	
A part of seat system does not operate (only automatic operation).	1. Sliding sensor circuit check	SE-60	D
	2. Reclining sensor circuit check	SE-61	E
	3. Front lifting sensor circuit check	SE-62	F
	4. Rear lifting sensor circuit check	SE-63	G
	5. If the above systems are normal, replace the driver seat control unit	SE-17	H
A part of door mirror system does not operate (only automatic operation).	1. Mirror sensor LH circuit check	SE-65	I
	2. Mirror sensor RH circuit check	SE-67	J
	3. If the above systems are normal, replace the automatic drive positioner control unit.	SE-17	K
All the automatic operations do not operate.	1. Key switch circuit check	SE-86	L
	2. Detention switch circuit check	SE-84	M
	3. UART communication line circuit check	SE-90	
	4. Pedal adjusting sensor circuit check	SE-64	
	5. If all the above systems are normal, replace the automatic drive positioner control unit.	SE-17	
A part of seat system does not operate (only manual operation).	1. Sliding switch circuit check	SE-69	SE
	2. Reclining switch circuit check	SE-70	
	3. Front lifting switch circuit check	SE-72	J
	4. Rear lifting switch circuit check	SE-73	K
	5. If the above systems are normal, replace the driver seat control unit	SE-17	L
A part of pedal adjust and door mirror does not operate (only manual operation).	1. Pedal adjusting switch circuit check	SE-75	M
	2. Door mirror remote control switch (change over switch) circuit check	SE-77	
	3. Door mirror remote control switch (mirror switch) switching circuit check	SE-78	
	4. If the above systems are normal, replace the automatic drive positioner control unit	SE-17	
Only memory switch operation.	1. Seat memory switch circuit check	SE-80	
	2. If the above systems are normal, replace the driver seat control unit	SE-17	
Seat memory indicator lamps 1 and 2 do not illuminate.	1. Seat memory indicator lamp circuit check	SE-82	
	2. If all the above systems are normal, replace the driver seat control unit.	SE-17	
The Entry/Exiting does not operated when door is opened and closed. (The Entry/Exiting operates with key switch)	1. Front door switch circuit check	BL-45	
	2. If all the above systems are normal, replace the BCM.	SE-17	
Only door mirror system does not operate (only manual operation).	Door mirror remote control switch ground circuit check	SE-80	
Only door mirror system does not operated (only automatic operation).	Door mirror sensor power supply and ground circuit check	SE-83	

AUTOMATIC DRIVE POSITIONER

Symptom	Diagnoses / service procedure	Refer to page
Only seat system does not operate (only manual operation).	Power seat switch ground circuit check	SE-74
Only number support does not operate.	Number support circuit check	SE-91

Sliding Motor Circuit Check

AIS003GQ

1. CHECK SEAT SLIDING MECHANISM

Check the following.

- Operation malfunction caused by sliding rail deformation or pinched harness or other foreign materials
- Operation malfunction caused by foreign materials adhered to the sliding motor or sliding rail connector rod
- Operation malfunction and interference with other parts by poor installation

OK or NG

OK >> GO TO 2.

NG >> Repair the malfunctioning part and check again.

2. CHECK FUNCTION

 **With CONSULT-II**

Check operation with "SEAT SLIDE" in ACTIVE TEST.

Test item	Description
SEAT SLIDE	The sliding motor is activated by receiving the drive signal.

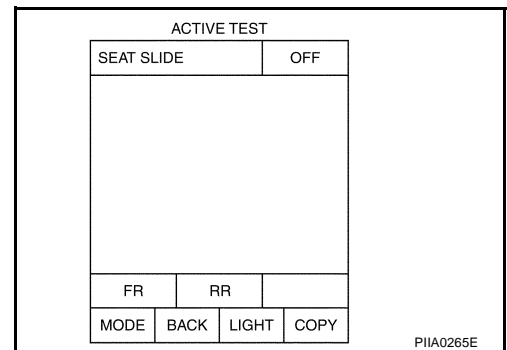

 **Without CONSULT-II**

GO TO 3.

OK or NG

OK >> Sliding motor circuit is OK.

NG >> GO TO 3.

AUTOMATIC DRIVE POSITIONER

3. CHECK SLIDING MOTOR CIRCUIT HARNESS CONTINUITY

1. Turn ignition switch OFF.
2. Disconnect driver seat control unit connector and sliding motor connector.
3. Check continuity between driver seat control unit connector B304 terminals 35 (W), 42 (BR) and sliding motor connector B307 terminals 35 (W), 42 (BR).

35 (W) – 35 (W) : Continuity should exist.

42 (BR) – 42 (BR) : Continuity should exist.

4. Check continuity between driver seat control unit connector B304 terminals 35 (W), 42 (BR) and ground.

35 (W) – Ground : Continuity should not exist.

42 (BR) – Ground : Continuity should not exist.

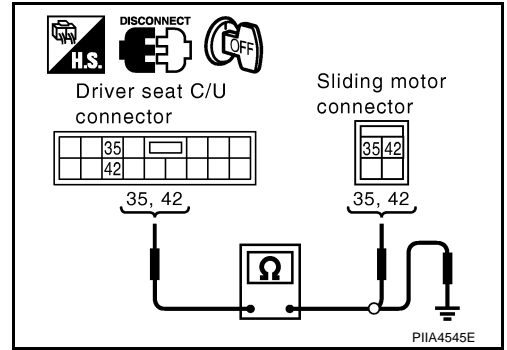

OK or NG

OK >> GO TO 4.

NG >> Repair or replace harness between driver seat control unit and sliding motor.

4. CHECK DRIVER SEAT CONTROL UNIT OUTPUT SIGNAL

1. Connect the driver seat control unit connector and sliding motor connector.
2. Check voltage between driver seat control unit connector and ground.

Connector	Terminals (Wire color)		Condition	Voltage (V) (Approx)
	(+)	(-)		
B304	35 (W)	Ground	Sliding switch ON (FR operation)	Battery voltage
			Sliding switch OFF	0
	42 (BR)		Sliding switch ON (RR operation)	Battery voltage
			Sliding switch OFF	0

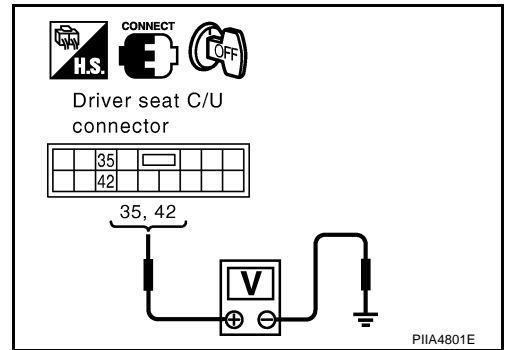

OK or NG

OK >> Replace sliding motor.

NG >> Replace driver seat control unit.

Reclining Motor Circuit Check

AIS003GR

1. CHECK SEAT RECLINING MECHANISM

Check the following.

- Operation malfunction caused by an interference with the center pillar or center console
- Operation malfunction and interference with other parts by poor installation

OK or NG

OK >> GO TO 2.

NG >> Repair the malfunctioning part and check again.

AUTOMATIC DRIVE POSITIONER

2. CHECK FUNCTION

With CONSULT-II

Check operation with "SEAT RECLINING" in ACTIVE TEST.

Test item	Description
SEAT RECLINING	The reclining motor is activated by receiving the drive signal.

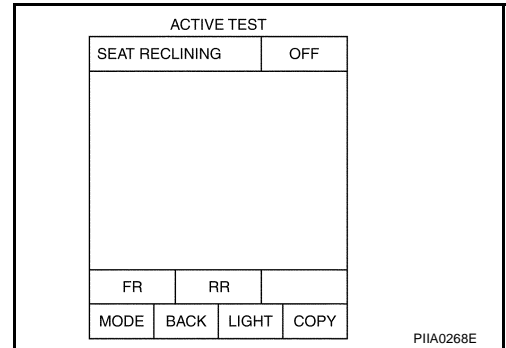

Without CONSULT-II

GO TO 3.

OK or NG

- OK >> Reclining motor circuit is OK.
- NG >> GO TO 3.

3. CHECK RECLINING MOTOR CIRCUIT HARNESS CONTINUITY

1. Turn ignition switch OFF.
2. Disconnect driver seat control unit connector and reclining motor connector.
3. Check continuity between driver seat control unit connector B304 terminals 36 (G), 44 (LG) and reclining motor connector B311 terminals 36 (G), 44 (LG).

36 (G) – 36 (G) : Continuity should exist.

44 (LG) – 44 (LG) : Continuity should exist.

4. Check continuity between driver seat control unit connector B304 terminals 36 (G), 44 (LG) and ground.

36 (G) – Ground : Continuity should not exist.

44 (LG) – Ground : Continuity should not exist.

OK or NG

- OK >> GO TO 4.
- NG >> Repair or replace harness between driver seat control unit and reclining motor.

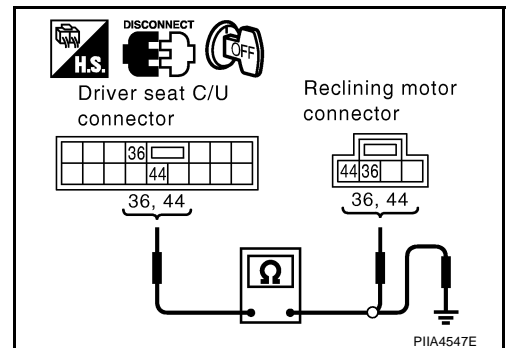

AUTOMATIC DRIVE POSITIONER

4. CHECK DRIVER SEAT CONTROL UNIT OUTPUT SIGNAL

1. Connect the driver seat control unit and reclining motor connector.
2. Check voltage between driver seat control unit connector and ground.

Connector	Terminals (Wire color)		Condition	Voltage (V) (Approx)
	(+)	(-)		
B304	36 (G)	Ground	Reclining switch ON (FR operation)	Battery voltage
			Reclining switch OFF	0
	44 (LG)		Reclining switch ON (RR operation)	Battery voltage
			Reclining switch OFF	0

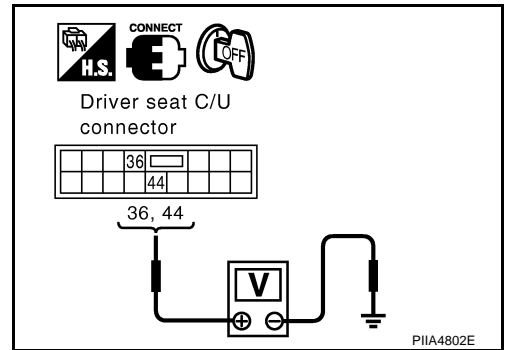

OK or NG

- OK >> Replace reclining motor.
 NG >> Replace driver seat control unit.

A
B
C
D
E
F
G
H
SE
J
K
L
M

AUTOMATIC DRIVE POSITIONER

AI5003GS

Front Lifting Motor Circuit Check

1. CHECK FRONT END SEAT LIFTING MECHANISM

Check the following.

- Operation malfunction caused by lifter mechanism deformation or pinched harness or other foreign materials
- Operation malfunction caused by foreign materials adhered to the lifter motor or lead screws
- Operation malfunction and interference with other parts by installation

OK or NG

OK >> GO TO 2.

NG >> Repair the malfunctioning part and check again.

2. CHECK FUNCTION

 **With CONSULT-II**

Check operation with "SEAT LIFTER FR" in ACTIVE TEST.

Test item	Description
SEAT LIFTER FR	The front end lifter motor is activated by receiving the drive signal.

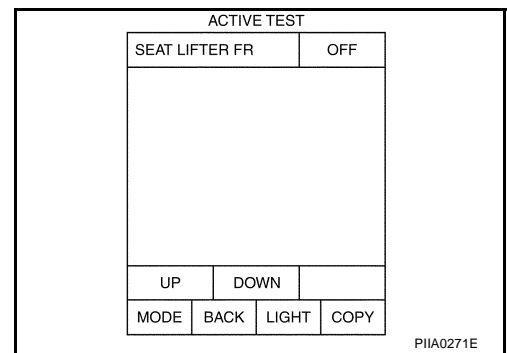

 **Without CONSULT-II**

GO TO 3.

OK or NG

OK >> Front lifting motor circuit is OK.

NG >> GO TO 3.

3. CHECK FRONT LIFTING MOTOR CIRCUIT HARNESS CONTINUITY

1. Turn ignition switch OFF.
2. Disconnect driver seat control unit connector and front lifting motor connector.
3. Check continuity between driver seat control unit connector B304 terminals 37 (V), 45 (O) and front lifting motor connector B309 terminals 37 (V), 45 (O).

37 (V) – 37 (V) : Continuity should exist.

45 (O) – 45 (O) : Continuity should exist.

4. Check continuity between driver seat control unit connector B304 terminals 37 (V), 45 (O) and ground.

37 (V) – Ground : Continuity should not exist.

45 (O) – Ground : Continuity should not exist.

OK or NG

OK >> GO TO 4.

NG >> Repair or replace harness between driver seat control unit and front lifting motor.

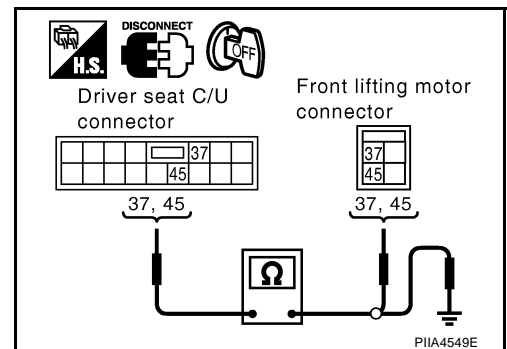

AUTOMATIC DRIVE POSITIONER

4. CHECK DRIVER SEAT CONTROL UNIT OUTPUT SIGNAL

1. Connect the driver seat control unit connector and front lifting motor connector.
2. Check voltage between driver seat control unit connector and ground.

Connector	Terminals (Wire color)		Condition	Voltage (V) (Approx)
	(+)	(-)		
B304	37 (V)	Ground	Front lifting switch ON (DOWN operation)	Battery voltage
			Front lifting switch OFF	0
	45 (O)		Front lifting switch ON (UP operation)	Battery voltage
			Front lifting switch OFF	0

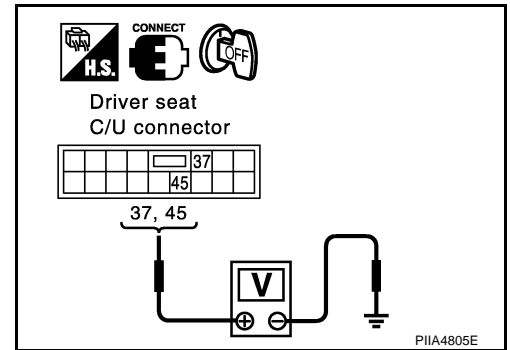

OK or NG

- OK >> Replace front lifting motor.
- NG >> Replace driver seat control unit.

Rear Lifting Motor Circuit Check

AIS003GT

1. CHECK REAR END SEAT LIFTING MECHANISM

Check the following.

- Operation malfunction caused by lifter mechanism deformation or pinched harness or other foreign materials
- Operation malfunction caused by foreign materials adhered to the lifter motor or lead screws
- Operation malfunction and interference with other parts by poor installation

OK or NG

- OK >> GO TO 2.
- NG >> Repair the malfunctioning part and check again.

2. CHECK FUNCTION

With CONSULT-II

Check operation with "SEAT LIFTER RR" in ACTIVE TEST.

Test item	Description
SEAT LIFTER RR	The rear end lifter motor is activated by receiving the drive signal.

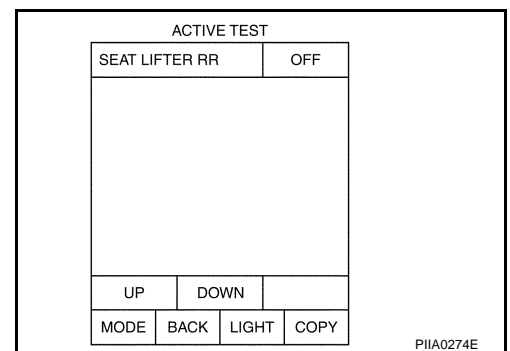

Without CONSULT-II

GO TO 3.

OK or NG

- OK >> Rear lifting motor circuit is OK.
- NG >> GO TO 3.

AUTOMATIC DRIVE POSITIONER

3. CHECK REAR LIFTING MOTOR CIRCUIT HARNESS CONTINUITY

1. Turn ignition switch OFF.
2. Disconnect driver seat control unit connector and rear lifting motor connector.
3. Check continuity between driver seat control unit connector B304 terminals 38 (L), 39 (Y) and rear lifting motor connector B310 terminals 38 (L), 39 (Y).

38 (L) – 38 (L) : Continuity should exist.
39 (Y) – 39 (Y) : Continuity should exist.

4. Check continuity between driver seat control unit B304 terminals 38 (L), 39 (Y) and ground.

38 (L) – Ground : Continuity should not exist.
39 (Y) – Ground : Continuity should not exist.

OK or NG

OK >> GO TO 4.

NG >> Repair or replace harness between driver seat control unit and rear lifting motor.

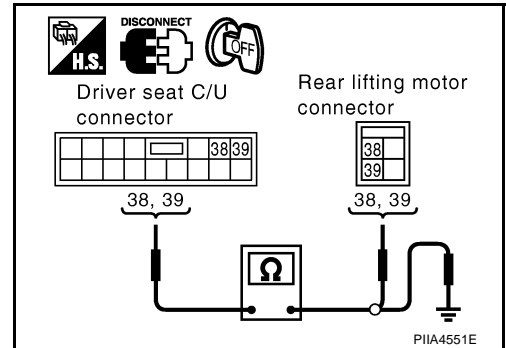

4. CHECK DRIVER SEAT CONTROL UNIT OUTPUT SIGNAL

1. Connect the driver seat control unit and rear lifting motor.
2. Check voltage between driver seat control unit connector and ground.

Connector	Terminals (Wire color)		Condition	Voltage (V) (Approx)
	(+)	(-)		
B304	38 (L)	Ground	Rear lifting switch ON (UP operation)	Battery voltage
			Rear lifting switch OFF	0
	39 (Y)		Rear lifting switch ON (DOWN operation)	Battery voltage
			Rear lifting switch OFF	0

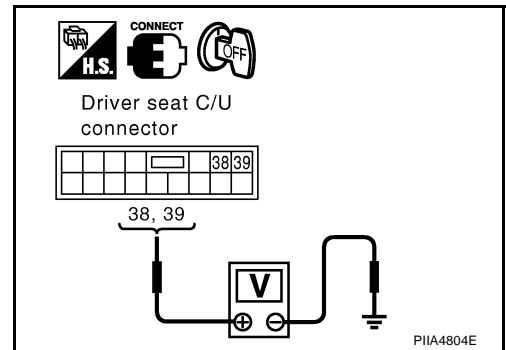

OK or NG

OK >> Replace rear lifting motor.

NG >> Replace driver seat control unit.

Pedal Adjusting Motor Circuit Check

AIS003GU

1. CHECK PEDAL ADJUSTING MECHANISM

Check the following.

- Operation malfunction caused by pedal adjusting mechanism deformation or pinched harness or other foreign materials
- Operation malfunction and interference with other parts by poor installation

OK or NG

OK >> GO TO 2.

NG >> Repair the malfunctioning part and check again.

AUTOMATIC DRIVE POSITIONER

2. CHECK FUNCTION

With CONSULT-II

Check operation with "PEDAL" in ACTIVE TEST.

Test item	Description
ADJ PEDAL MOTOR	The pedal adjust motor is activated by receiving the drive signal.

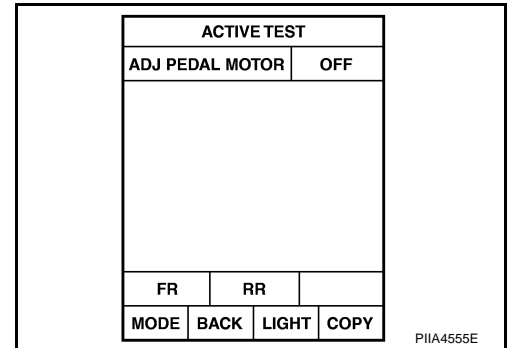

Without CONSULT-II

GO TO 3.

OK or NG

- OK >> Pedal adjusting motor circuit is OK.
- NG >> GO TO 3.

3. CHECK PEDAL ADJUSTING MOTOR CIRCUIT HARNESS CONTINUITY

1. Turn ignition switch OFF.
2. Disconnect automatic drive positioner control unit and pedal adjusting motor connector.
3. Check continuity between automatic drive positioner control unit connector M20 terminals 37 (L/R), 45 (L/Y) and pedal adjusting motor connector E113 terminals 1 (L/Y), 2 (L/R).

37 (L/R) – 2 (L/R) : Continuity should exist.

45 (L/Y) – 1 (L/Y) : Continuity should exist.

4. Check continuity between automatic drive positioner control unit connector M20 terminals 37 (L/R), 45 (L/Y) and ground.

37 (L/R) – Ground : Continuity should not exist.

45 (L/Y) – Ground : Continuity should not exist.

OK or NG

- OK >> GO TO 4.
- NG >> Repair or replace harness between automatic drive positioner control unit and pedal adjust motor.

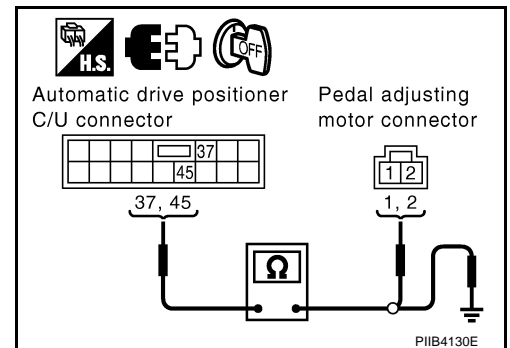

AUTOMATIC DRIVE POSITIONER

4. CHECK AUTOMATIC DRIVE POSITINER CONTROL UNIT OUTPUT SIGNAL

1. Connect the automatic drive positioner control unit connector and pedal adjusting motor connector.
2. Check voltage between automatic drive positioner control unit connector and ground.

Connector	Terminals (Wire color)		Condition	Voltage (V) (Approx)
	(+)	(-)		
M20	37 (L/R)	Ground	Pedal adjusting switch ON (FR operation)	Battery voltage
			Pedal adjusting switch OFF	0
	45 (L/Y)		Pedal adjusting switch ON (RR operation)	Battery voltage
			Pedal adjusting switch OFF	0

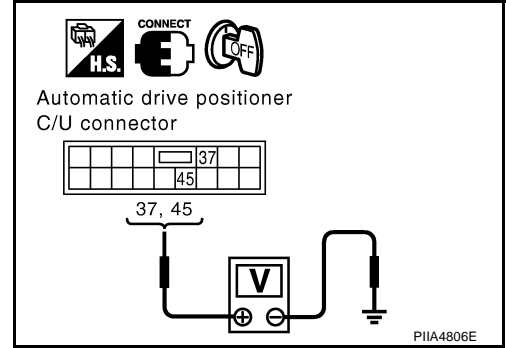

OK or NG

- OK >> Replace pedal adjusting motor.
- NG >> Replace automatic drive positioner control unit.

Mirror Motor LH Circuit Check

AIS003HC

1. CHECK DOOR MIRROR LH MECHANISM

Check the following items.
Operation malfunction caused by a foreign object caught in door mirror face edge.

OK or NG

- OK >> GO TO 2.
- NG >> Repair the malfunctioning parts, and check the symptom again.

2. CHECK FUNCTION

With CONSULT-II

Check the operation with "MIRROR MOTOR LH" in the ACTIVE TEST.

Test item	Description
MIRROR MOTO RLH	The LH mirror motor moves the mirror UP/DOWN and LEFT/RIGHT by receiving the drive signal.

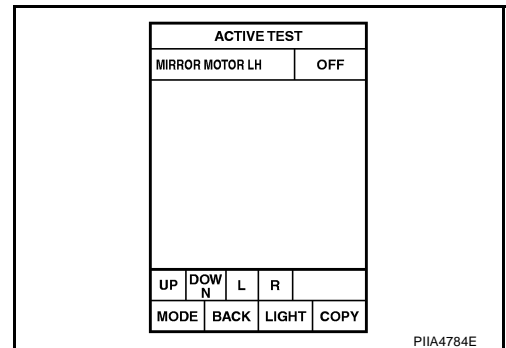

Without CONSULT-II

GO TO 3.

OK or NG

- OK >> Mirror motor LH circuit is OK.
- NG >> GO TO 3.

AUTOMATIC DRIVE POSITIONER

3. CHECK MIRROR MOTOR LH CIRCUIT HARNESS CONTINUITY

1. Turn ignition switch OFF.
2. Disconnect automatic drive positioner control unit and door mirror (driver side) connector.
3. Check continuity between automatic drive positioner control unit connector M19 terminal 16 (LG/R), 31 (R/L), 32 (BR) and door mirror (driver side) connector D2 terminal 8 (R/L), 9 (BR), 10 (LG/R).

16 (LG/R) – 10 (LG/R) :Continuity should exist.
31 (R/L) – 8 (R/L) :Continuity should exist.
32 (BR) – 9 (BR) :Continuity should exist.

4. Check continuity between automatic drive positioner control unit connector M19 terminal 16 (LG/R), 31 (R/L), 32 (BR) and ground.

16 (LG/R) – Ground :Continuity should not exist.
31 (R/L) – Ground :Continuity should not exist.
32 (BR) – Ground :Continuity should not exist.

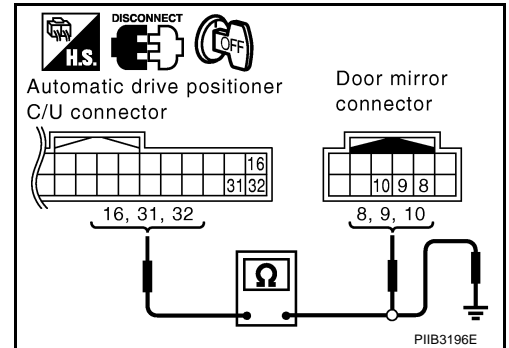

OK or NG

OK >> GO TO 4.

NG >> Repair or replace harness between automatic drive positioner control unit and door mirror (driver side).

4. CHECK MIRROR MOTOR SIGNAL

1. Connect automatic drive positioner control unit connector.
2. Turn ignition switch ACC.
3. Check voltage between door mirror (driver side) connector and ground.

Con- nector	Terminals (Wire color)		Condition	Voltage (V) (Approx)
	(+)	(-)		
D2	8 (R/L)	Ground	When motor is UP operation	1.5 - Battery voltage
			Mirror motor LH OFF	0
	9 (BR)		When motor is LEFT operation	1.5 - Battery voltage
			Mirror motor LH OFF	0
	10 (LG/R)		When motor is DOWN or RIGHT operation	1.5 - Battery voltage
			Mirror motor LH OFF	0

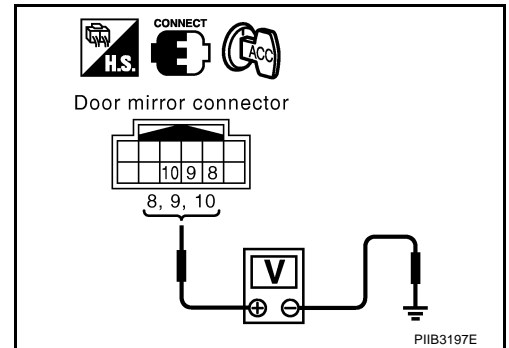

OK or NG

OK >> Replace door mirror motor (driver side).

NG >> Check the condition of the harness and the connector.

AUTOMATIC DRIVE POSITIONER

AIS003HD

Mirror Motor RH Circuit Check

1. CHECK DOOR MIRROR RH MECHANISM

Check the following items.

Operation malfunction caused by a foreign object caught in door mirror face edge.

OK or NG

OK >> GO TO 2.

NG >> Repair the malfunctioning parts, and check the symptom again.

2. CHECK FUNCTION

With CONSULT-II

Check the operation with "MIRROR MOTOR RH" in the ACTIVE TEST.

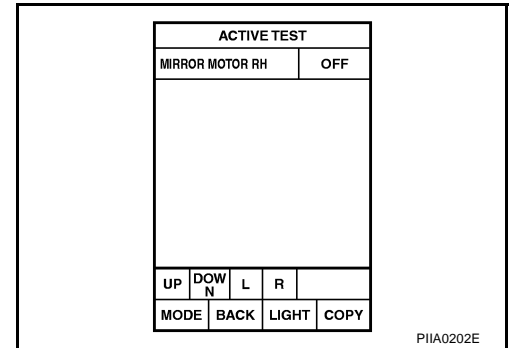

Test item	Description
MIRROR MOTOR RH	The RH mirror motor moves the mirror UP/DOWN and LEFT/RIGHT by receiving the drive signal.

Without CONSULT-II

GO TO 3.

OK or NG

OK >> Mirror motor RH circuit is OK.

NG >> GO TO 3.

3. CHECK DOOR MIRROR RH CIRCUIT HARNESS CONTINUITY

- Turn ignition switch OFF.
- Disconnect automatic drive positioner control unit and door mirror (passenger side) connector.
- Check continuity between automatic drive positioner control unit connector M19 terminal 14 (GR/R), 15 (LG), 30 (SB) and door mirror (passenger side) connector D32 terminal 8 (GR/R), 9 (LG), 10 (SB).

14 (GR/R) – 8 (GR/R) :Continuity should exist.

15 (LG) – 9 (LG) :Continuity should exist.

30 (SB) – 10 (SB) :Continuity should exist.

- Check continuity between automatic drive positioner control unit connector M19 terminal 14 (GR/R), 15 (LG), 30 (SB) and ground.

14 (GR/R) – Ground :Continuity should not exist.

15 (LG) – Ground :Continuity should not exist.

30 (SB) – Ground :Continuity should not exist.

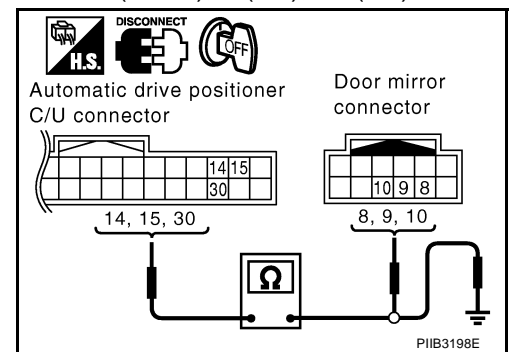

OK or NG

OK >> GO TO 4.

NG >> Repair or replace harness between automatic drive positioner control unit and door mirror (passenger side).

AUTOMATIC DRIVE POSITIONER

4. CHECK MIRROR MOTOR SIGNAL

1. Connect automatic drive positioner control unit connector.
2. Turn ignition switch ACC.
3. Check voltage between door mirror (passenger side) connector and ground.

Connector	Terminals (Wire color)		Condition	Voltage (V) (Approx)
	(+)	(-)		
D32	8 (GR/R)	Ground	When motor is UP operation	1.5 - Battery voltage
			Mirror motor RH OFF	0
	9 (LG)		When motor is LEFT operation	1.5 - Battery voltage
			Mirror motor RH OFF	0
	10 (SB)		When motor is DOWN or RIGHT operation	1.5 - Battery voltage
			Mirror motor RH OFF	0

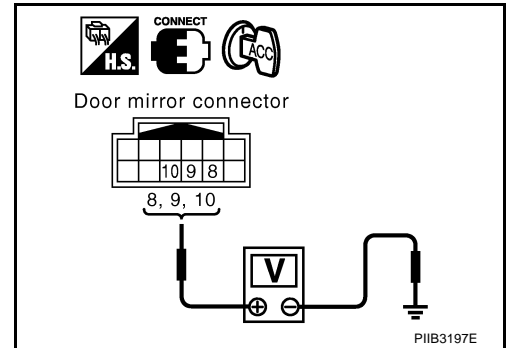

OK or NG

- OK >> Replace door mirror motor (passenger side).
 NG >> Check the condition of the harness and the connector.

A
B
C
D
E
F
G
H
J
K
L
M

SE

AUTOMATIC DRIVE POSITIONER

AI5003GV

Sliding Sensor Circuit Check

1. CHECK FUNCTION

With CONSULT-II

Check operation with "SLIDE PULSE" on the DATA MONITOR to make sure the pulse changes.

Monitor item [OPERATION or UNIT]	Contents
SLIDE PULSE	— The seat sliding position (pulse) judged from the sliding sensor signal is displayed

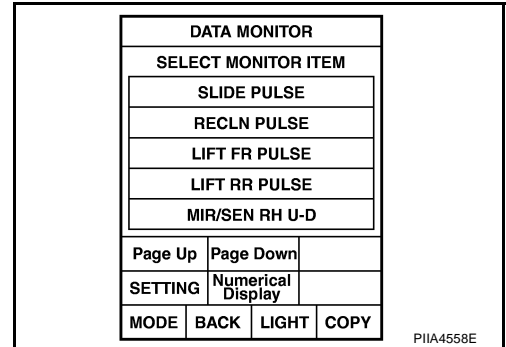

Without CONSULT-II

- Turn ignition switch OFF.
- Check signal between driver seat control unit connector and ground, with oscilloscope.

Connector	Terminals (Wire color)		Condition	Signal (Reference value)
	(+)	(-)		
B303	24 (G/B)	Ground	Sliding motor operation	<p>PIIA3277E</p>

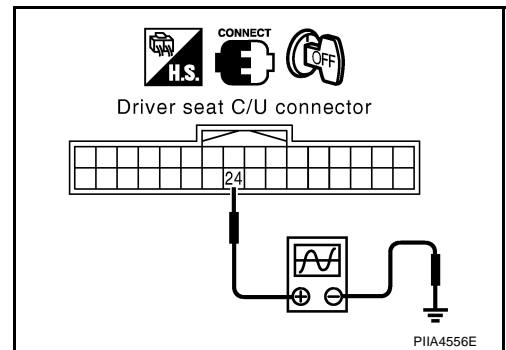

OK or NG

- OK >> Sliding sensor circuit is OK.
- NG >> GO TO 2.

2. CHECK SLIDING SENSOR CIRCUIT HARNESS CONTINUITY

- Disconnect driver seat control unit connector and sliding motor connector.
- Check continuity between driver seat control unit connector B303 terminals 24 (G/B), 31 (R/W) and sliding motor B307 terminals 24 (G/B), 31A (R/W).

24 (G/B) – 24 (G/B) : Continuity should exist.

31 (R/W) – 31A (R/W) : Continuity should exist.

- Check continuity between driver seat control unit B303 terminals 24 (G/B), 31 (R/W) and ground.

24 (G/B) – Ground : Continuity should not exist.

31 (R/W) – Ground : Continuity should not exist.

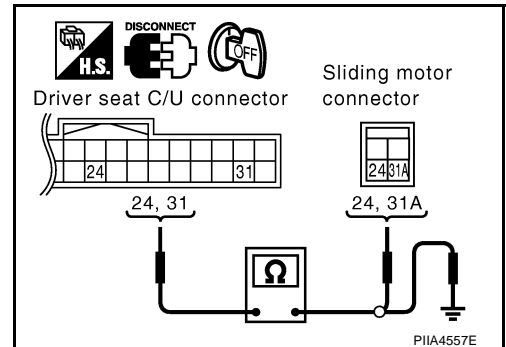

OK or NG

- OK >> Replace sliding motor.
- NG >> Repair or replace harness between driver seat control unit and sliding motor.

AUTOMATIC DRIVE POSITIONER

AIS003GW

Reclining Sensor Circuit Check

1. CHECK FUNCTION

With CONSULT-II

Check operation with "RECLINING PULSE" on the DATA MONITOR to make sure the pulse changes.

Monitor item [POERATION or UNIT]	Contents
RECLN PULSE	—
	The seat reclining position (pulse) judged from the reclining sensor is displayed

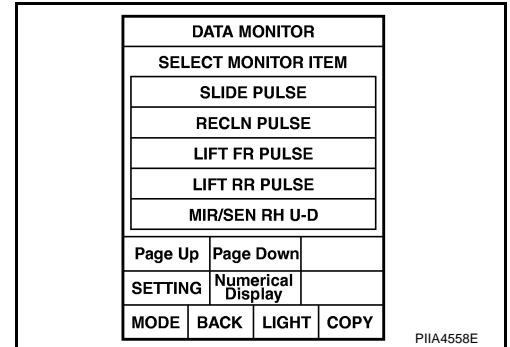

Without CONSULT-II

- Turn ignition switch OFF.
- Check signal between driver seat control unit connector and ground, with oscilloscope.

Connector	Terminals (Wire color)		Condition	Signal (Reference value)
	(+)	(-)		
B303	9 (L)	Ground	Reclining motor operation	

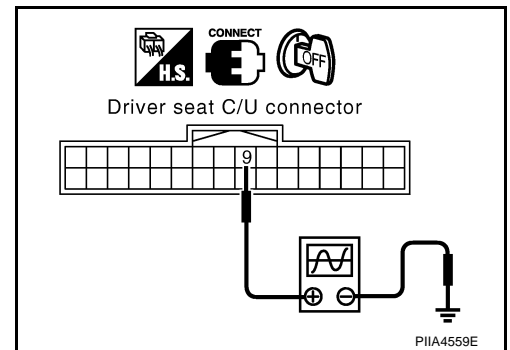

OK or NG

- OK >> Reclining sensor circuit is OK.
 NG >> GO TO 2.

2. CHECK RECLINING SENSOR CIRCUIT HARNESS CONTINUITY

- Disconnect driver seat control unit connector and reclining motor connector.
- Check continuity between driver seat control unit connector B303 terminals 9 (L), 31 (R/W) and reclining motor connector B311 terminals 9 (L), 31 (R/W).

9 (L) – 9 (L) : Continuity should exist.

31 (R/W) – 31 (R/W) : Continuity should exist.

- Check continuity between driver seat control unit connector B303 terminals 9 (L), 31 (R/W) and ground.

9 (L) – Ground : Continuity should not exist.

31 (R/W) – Ground : Continuity should not exist.

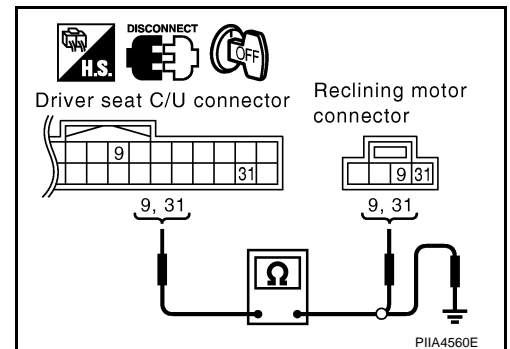

OK or NG

- OK >> Replace reclining motor.
 NG >> Repair or replace harness between connectors driver seat control unit and reclining motor.

AUTOMATIC DRIVE POSITIONER

AI5003GX

Front Lifting Sensor Circuit Check

1. CHECK FUNCTION

With CONSULT-II

Check operation with "LIFT FR PULSE" on the DATA MONITOR to make sure the pulse changes.

Monitor item [OPERATION or UNIT]	Contents
LIFT FR PULSE	— The front lifting position (pulse) judged from the front lifting sensor is displayed

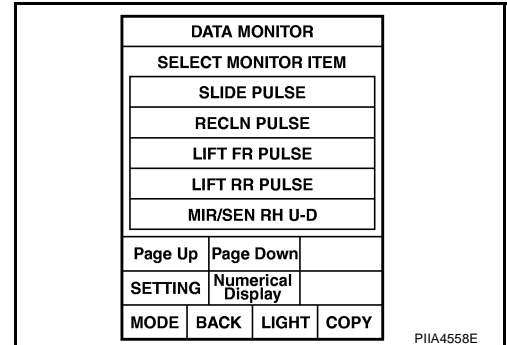

Without CONSULT-II

- Turn ignition switch OFF.
- Check signal between driver seat control unit connector and ground, with oscilloscope.

Connector	Terminals (Wire color)		Condition	Signal (Reference value)
	(+)	(-)		
B303	25 (Y/B)	Ground	Front lifting motor operation	<p>PIIA3278E</p>

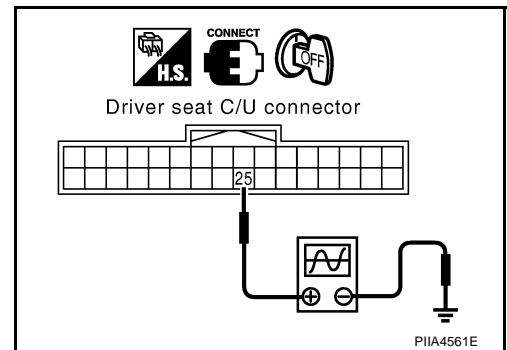

OK or NG

- OK >> Front lifting sensor is OK.
 NG >> GO TO 2.

2. CHECK FRONT LIFTINGS SENSOR CIRCUIT HARNESS CONTINUITY

- Disconnect driver seat control unit connector and front lifting motor connector.
- Check continuity between driver seat control unit connector B303 terminals 25 (Y/B), 31 (R/W) and front lifting motor connector B309 terminals 25 (Y/B), 31B (R/W).

25 (Y/B) – 25 (Y/B) : Continuity should exist.

31 (R/W) – 31B (R/W) : Continuity should exist.

- Check continuity between driver seat control unit connector B303 terminals 25 (Y/B), 31 (R/W) and ground.

25 (Y/B) – Ground : Continuity should not exist.

31 (R/W) – Ground : Continuity should not exist.

OK or NG

- OK >> Replace front lifting motor.
 NG >> Repair or replace harness between driver seat control unit and front lifting motor.

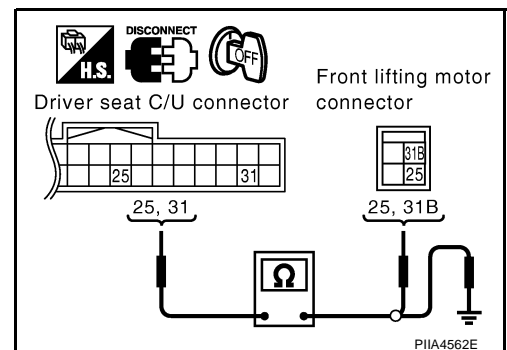

AUTOMATIC DRIVE POSITIONER

Rear Lifting Sensor Circuit Check

AIS003GY

1. CHECK REAR END LIFTING SENSOR INPUT/OUTPUT SIGNAL

With CONSULT-II

Check operation with "LIFT RR PULSE" on the DATA MONITOR to make sure pulse changes.

Monitor item [OPERATION or UNIT]		
LIFT RR PULSE	—	The rear lifting position (pulse) judged from the rear lifting sensor is displayed.

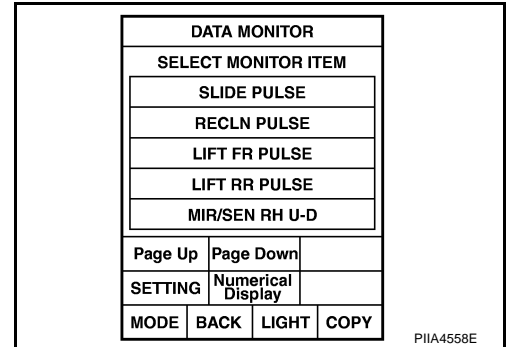

Without CONSULT-II

- Turn ignition switch OFF.
- Check signal between driver seat control unit connector and ground, with oscilloscope.

Connector	Terminals (Wire color)		Condition	Signal
	(+)	(-)		
B303	10 (W/R)	Ground	Rear lifting motor operation	

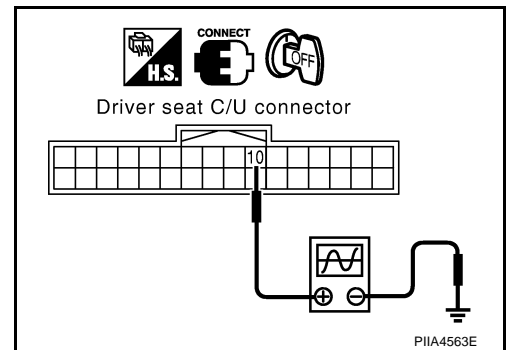

OK or NG

- OK >> Rear lifting sensor circuit is OK.
 NG >> GO TO 2.

2. CHECK REAR LIFTING SENSOR CIRCUIT HARNESS CONTINUITY

- Disconnect driver seat control unit connector and rear lifting motor connector.
- Check continuity between driver seat control unit connector B303 terminals 10 (W/R), 31 (R/W) and rear lifting motor connector B310 terminals 10 (W/R), 31C (R/W).

10 (W/R) – 10 (W/R) : Continuity should exist.

31 (R/W) – 31C (R/W) : Continuity should exist.

- Check continuity between driver seat control unit connector B303 terminals 10 (W/R), 31 (R/W) and ground.

10 (W/R) – Ground : Continuity should not exist.

31 (R/W) – Ground : Continuity should not exist.

OK or NG

- OK >> Replace rear lifting motor.
 NG >> Repair or replace harness between driver seat control unit and rear lifting motor.

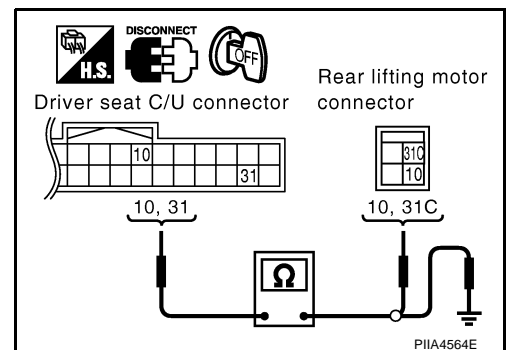

AUTOMATIC DRIVE POSITIONER

AIS003GZ

Pedal Adjusting Sensor Circuit Check

1. CHECK FUNCTION

④ With CONSULT-II

Operate the pedal adjusting switch with "PEDAL SEN" on the DATA MONITOR to make sure the voltage changes.

Monitor item [OPERATION or UNIT]	Contents	
PEDAL SEN	"V"	The pedal adjusting position (voltage) judged from the pedal adjust sensor signal is displayed.

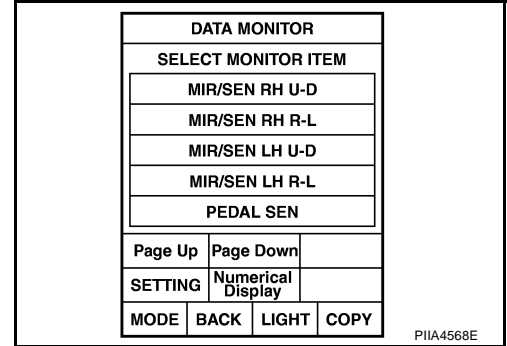

⊗ Without CONSULT-II

1. Turn ignition switch OFF.
2. Check voltage between automatic drive positioner connector and ground.

Connector	Terminals (Wire color)		Condition	Voltage (V) (Approx)
	(+)	(-)		
M19	8 (P/B)	Ground	Pedal front end position	0.5
			Pedal back end position	4.5

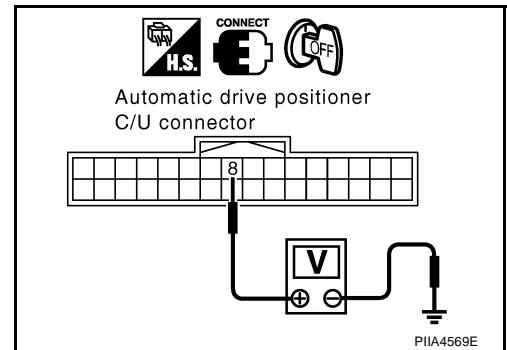

OK or NG

- OK >> Pedal adjusting sensor circuit is OK.
- NG >> GO TO 2.

AUTOMATIC DRIVE POSITIONER

2. CHECK PEDAL ADJUSTING SENSOR CIRCUIT HARNESS CONTINUITY

1. Disconnect automatic drive positioner control unit and pedal adjusting motor connector.
2. Check continuity between automatic drive positioner connector M19, M20 terminals 8 (P/B), 33 (W/L), 41 (Y) and pedal adjusting motor connector E114 terminals 3 (Y), 4 (P/B), 5 (W/L).

8 (P/B) – 4 (P/B) : Continuity should exist.

33 (W/L) – 5 (W/L) : Continuity should exist.

41 (Y) – 3 (Y) : Continuity should exist.

3. Check continuity between automatic drive positioner control unit connector E114 terminals 8 (P/B), 33 (W/L), 41 (Y) and ground.

8 (P/B) – Ground : Continuity should not exist.

33 (W/L) – Ground : Continuity should not exist.

41 (Y) – Ground : Continuity should not exist.

OK or NG

OK >> Replace pedal adjusting motor.

NG >> Repair or replace harness between automatic drive positioner and pedal adjusting sensor.

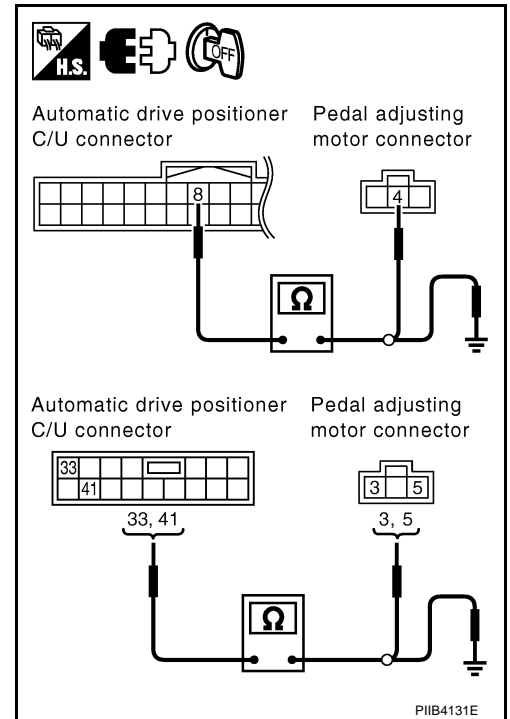

Mirror Sensor LH Circuit Check

1. CHECK DOOR MIRROR FUNCTION

Check the following items.
Operation malfunction in memory control

NOTE:

If a door mirror face position is set to an implausible angle, the set position may not be reproduced.

OK or NG

OK >> GO TO 2.

NG >> Repair the malfunctioning parts, and check the symptom again.

AUTOMATIC DRIVE POSITIONER

2. CHECK MIRROR SENSOR CHECK

With CONSULT-II

Check that "ON" is displayed on "MIR/SE LH R-L, MIR/SE LH U-D" in the DATA MONITOR.

Monitor item [OPERATION or UNIT]		Contents
MIR/SEN LH R-L	"√"	Voltage output from LH door mirror sensor (LH/RH) is displayed.
MIR/SEN LH U-D	"√"	Voltage output from LH door mirror sensor (UP/DOWN) is displayed.

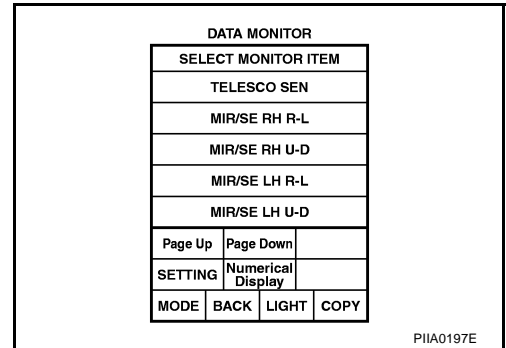

Without CONSULT-II

1. Turn ignition switch ACC.
2. Check voltage between door mirror (driver side) connector and ground.

Con-connector	Terminals (Wire color)		Condition	Voltage (V) (Approx.)
	(+)	(-)		
D2	1 (G)	Ground	When motor is LEFT or RIGHT operation	Changes between 3.4 (close to right edge) – 0.6 (close to left edge)
	4 (L/Y)		When motor is UP or DOWN operation	Changes between 3.4 (close to peak) – 0.6 (close to valley)

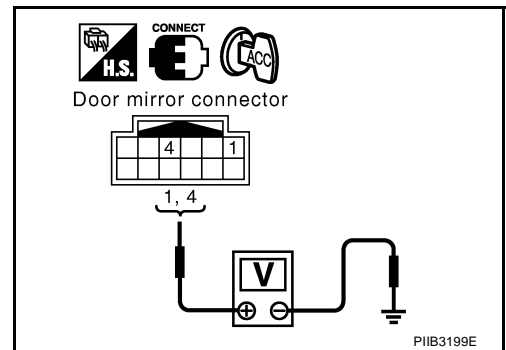

OK or NG

- OK >> Mirror sensor LH is OK.
 NG >> GO TO 3.

3. CHECK HARNESS CONTINUITY 1

1. Turn ignition switch OFF.
2. Disconnect automatic drive positioner control unit connector and door mirror (driver side) connector.
3. Check continuity between automatic drive positioner control unit connector M20 terminal 33 (W/L), 41 (Y) and door mirror (driver side) connector D2 terminal 3 (W/L), 2 (Y).

- 33 (W/L) – 3 (W/L) :Continuity should exist.**
41 (Y) – 2 (Y) :Continuity should exist.

4. Check continuity between automatic drive positioner control unit connector M20 terminal 33 (W/L), 41 (Y) and ground.

- 33 (W/L) – Ground :Continuity should not exist.**
41 (Y) – Ground :Continuity should not exist.

OK or NG

- OK >> GO TO 4.
 NG >> Repair or replace harness between automatic drive positioner control unit and door mirror (driver side).

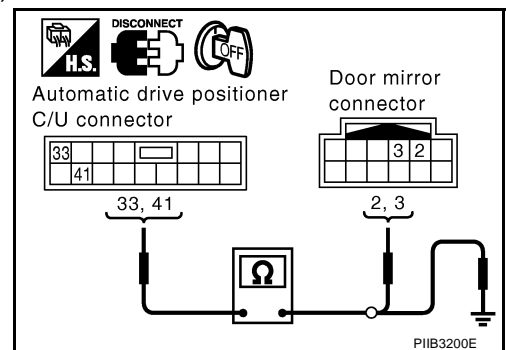

AUTOMATIC DRIVE POSITIONER

4. CHECK HARNESS CONTINUITY 2

- Check continuity between automatic drive positioner control unit connector M19 terminal 6 (L/Y), 22 (G) and door mirror (driver side) connector D2 terminal 1 (G), 4 (L/Y).

6 (L/Y) – 4 (L/Y) :Continuity should exist.
22 (G) – 1 (G) :Continuity should exist.

- Check continuity between automatic drive positioner control unit connector M19 terminal 6 (L/Y), 22 (G) and ground.

6 (L/Y) – Ground :Continuity should not exist.
22 (G) – Ground :Continuity should not exist.

OK or NG

- OK >> Replace door mirror (driver side).
 NG >> Repair or replace harness between automatic drive positioner control unit and door mirror (driver side).

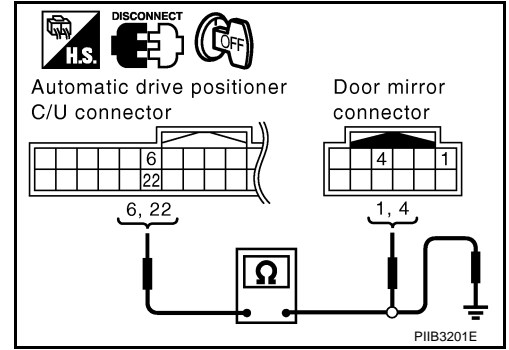

Mirror Sensor RH Circuit Check

1. CHECK DOOR MIRROR FUNCTION

Check the following items.
 Operation malfunction in memory control

NOTE:

If a door mirror face position is set to an implausible angle, the set position may not be reproduced.

OK or NG

- OK >> GO TO 2.
 NG >> Repair the malfunctioning parts, and check the symptom again.

2. CHECK MIRROR SENSOR CHECK

With CONSULT-II

Check that "ON" is displayed on "MIR/SE RH R-L, MIR/SE RH U-D" in the DATA MONITOR.

Monitor item [OPERATION or UNIT]		Contents
MIR/SEN RH R-L	"V"	Voltage output from RH door mirror sensor (LH/RH) is displayed.
MIR/SEN RH U-D	"V"	Voltage output from RH door mirror sensor (UP/DOWN) is displayed.

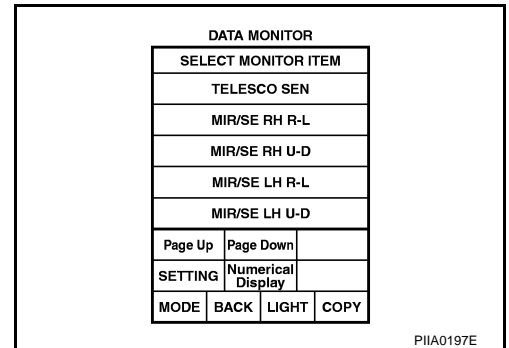

Without CONSULT-II

- Turn ignition switch ACC.
- Check voltage between door mirror (passenger side) connector and ground.

Connector	Terminals (Wire color)		Condition	Voltage(V) (Approx.)
	(+)	(-)		
D32	1 (L)	Ground	When motor is LEFT or RIGHT operation	Changes between 3.4 (close to left edge) – 0.6 (close to right edge)
	4 (R/B)		When motor is UP or DOWN operation	Changes between 3.4 (close to peak) – 0.6 (close to valley)

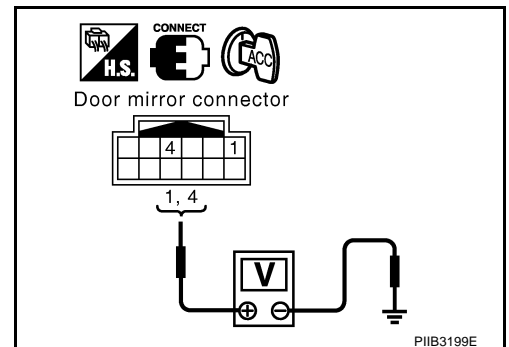

OK or NG

- OK >> Mirror sensor RH is OK.
 NG >> GO TO 3.

AUTOMATIC DRIVE POSITIONER

3. CHECK HARNESS CONTINUITY 1

1. Turn ignition switch OFF.
2. Disconnect automatic drive positioner control unit and door mirror (passenger side) connector.
3. Check continuity between automatic drive positioner control unit connector M20 terminal 33 (W/L), 41 (Y) and door mirror (passenger side) connector D32 terminal 3 (W/L), 2 (Y).

33 (W/L) – 3 (W/L) :Continuity should exist.

41 (Y) – 2 (Y) :Continuity should exist.

4. Check continuity between automatic drive positioner control unit connector M20 terminal 33 (W/L), 41 (Y) and ground.

33 (W/L) – Ground :Continuity should not exist.

41 (Y) – Ground :Continuity should not exist.

OK or NG

OK >> GO TO 4.

NG >> Repair or replace harness between automatic drive positioner control unit and door mirror (passenger side).

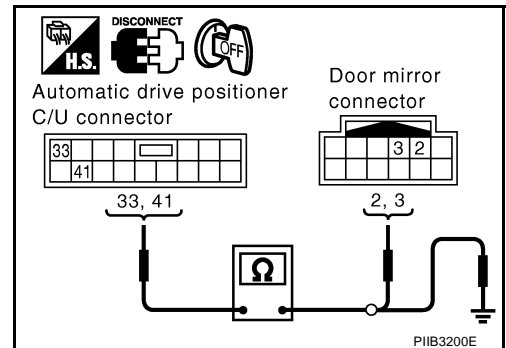

4. CHECK HARNESS CONTINUITY 2

1. Check continuity between automatic drive positioner control unit connector M19 terminal 5 (R/B), 21 (L) and door mirror (passenger side) connector D32 terminal 1 (L), 4 (R/B).

5 (R/B) – 4 (R/B) :Continuity should exist.

21 (L) – 1 (L) :Continuity should exist.

2. Check continuity between automatic drive positioner control unit connector M19 terminal 5 (R/B), 21 (L) and ground.

5 (R/B) – Ground :Continuity should not exist.

21 (L) – Ground :Continuity should not exist.

OK or NG

OK >> Replace door mirror (passenger side).

NG >> Repair or replace harness between automatic drive positioner control unit and door mirror (passenger side).

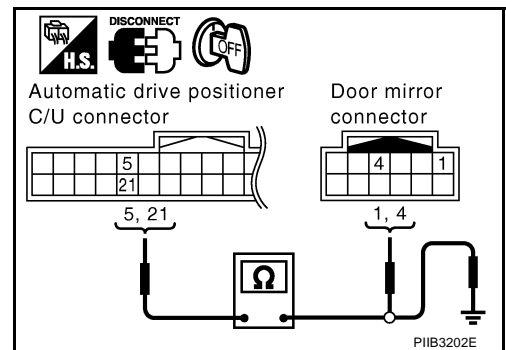

AUTOMATIC DRIVE POSITIONER

AI5003H4

Sliding Switch Circuit Check

1. CHECK FUNCTION

With CONSULT-II

With "SLIDE SW-FR, SLIDE SW-RR" on the DATA MONITOR, operate the sliding switch to check ON/OFF operation.

Monitor item [OPERATION or UNIT]		Contents
SLIDE SW-FR	"ON/OFF"	ON / OFF status judged from the sliding switch (FR) signal is displayed.
SLIDE SW-RR	"ON/OFF"	ON / OFF status judged from the sliding switch (RR) signal is displayed.

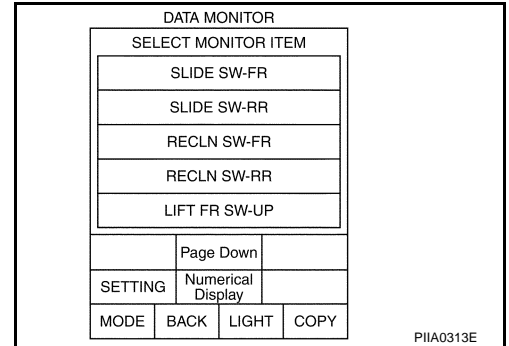

Without CONSULT-II

1. Turn ignition switch OFF.
2. Check voltage between driver seat control unit connector and ground.

Connector	Terminal (Wire color)		Condition	Voltage (V) (Approx)
	(+)	(-)		
B303	11 (W/V)	Ground	Sliding switch ON(RR operation)	0
			Sliding switch OFF	Battery voltage
	26 (G/W)		Sliding switch ON(FR operation)	0
			Sliding switch OFF	Battery voltage

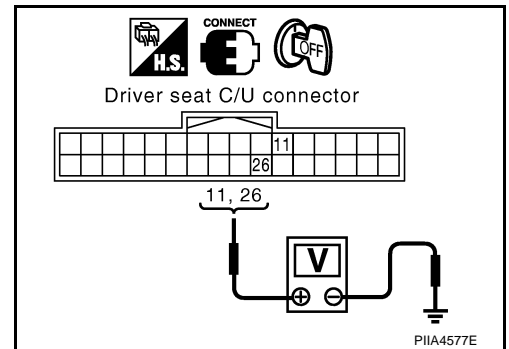

OK or NG

- OK >> Sliding switch circuit is OK.
 NG >> GO TO 2.

2. CHECK SLIDING SWITCH CIRCUIT HARNESS CONTINUITY

1. Disconnect driver seat control unit connector and power seat switch connector.
2. Check continuity between driver seat control unit connector B303 terminals 11 (W/V), 26 (G/W) and power seat switch connector B305 terminals 11 (W/V), 26 (G/W).

- 11 (W/V) – 11 (W/V) : Continuity should exist.**
26 (G/W) – 26 (G/W) : Continuity should exist.

3. Check continuity between driver seat control unit connector B303 terminals 11 (W/V), 26 (G/W) and ground.

- 11 (W/V) – Ground : Continuity should not exist.**
26 (G/W) – Ground : Continuity should not exist.

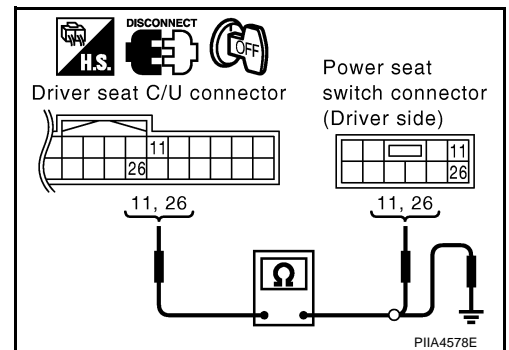

OK or NG

- OK >> GO TO 3.
 NG >> Repair or replace harness between driver seat control unit and power seat switch.

AUTOMATIC DRIVE POSITIONER

3. CHECK SLIDING SWITCH

Check continuity between power seat switch as follows.

Connector	Terminal	Condition	Continuity
B305	11	Sliding switch ON (RR operation)	Yes
		Sliding switch OFF	No
	26	Sliding switch ON (FR operation)	Yes
		Sliding switch OFF	No

OK or NG

- OK >> Check the condition of the harness and connector.
 NG >> Replace power seat switch.

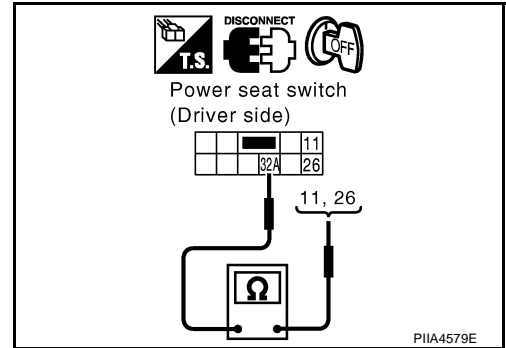

Reclining Switch Check

1. CHECK FUNCTION

With CONSULT-II

With "RECLINING SW-FR, RECLINING SW-RR" on the DATA MONITOR, operate the reclining switch to check ON/OFF operation.

Monitor item [OPERATION or UNIT]	Contents
RECLN SW-FR	"ON/OFF" ON/OFF status judged from the reclining switch (FR) signal is displayed.
RECLIN SW-RR	"ON/OFF" ON/OFF status judged from the reclining switch (RR) signal is displayed.

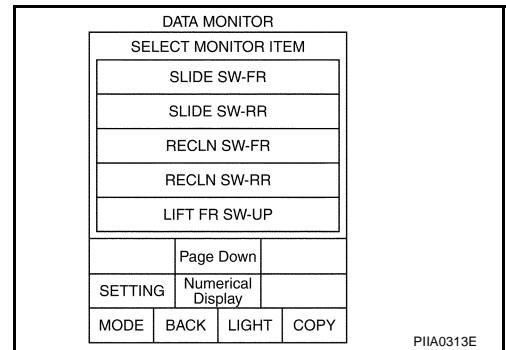

Without CONSULT-II

- Turn ignition switch OFF.
- Check voltage between driver seat control unit connector and ground.

Connector	Terminals (Wire color)		Condition	Voltage (V) (Approx)
	(+)	(-)		
B303	12 (G/Y)	Ground	Reclining switch ON (RR operation)	0
			Reclining switch OFF	Battery voltage
	27 (L/W)		Reclining switch ON (FR operation)	0
			Reclining switch OFF	Battery voltage

OK or NG

- OK >> Reclining switch circuit is OK.
 NG >> GO TO 2.

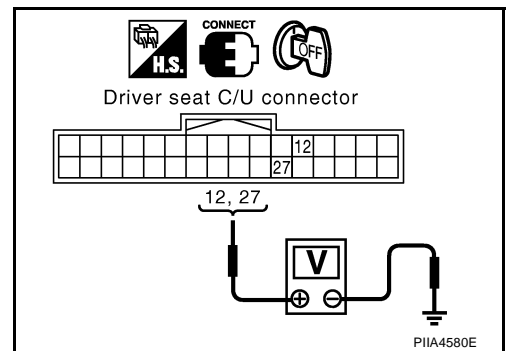

AUTOMATIC DRIVE POSITIONER

2. CHECK RECLINING SWITCH CIRCUIT HARNESS CONTINUITY

1. Disconnect driver seat control unit connector and power seat switch connector.
2. Check continuity between driver seat control unit connector B303 terminals 12 (G/Y), 27 (L/W) and power seat switch connector B305 terminals 12 (G/Y), 27 (L/W).

12 (G/Y) – 12 (G/Y) : Continuity should exist.
27 (L/W) – 27 (L/W) : Continuity should exist.

3. Check continuity between driver seat control unit connector B303 terminals 12 (G/Y), 27 (L/W) and ground.

12 (G/Y) – Ground : Continuity should not exist.
27 (L/W) – Ground : Continuity should not exist.

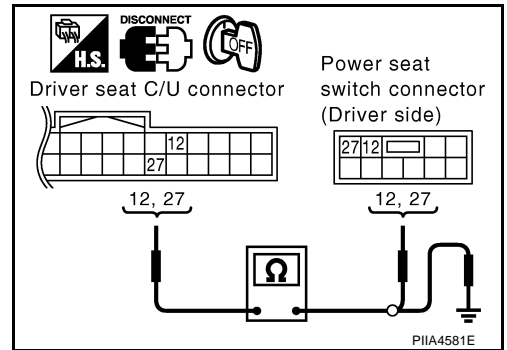

OK or NG

OK >> GO TO 3.

NG >> Repair or replace harness between driver seat control unit and power seat switch.

3. RECLINING SWITCH CHECK

Check continuity between driver seat switch as follows.

Connector	Terminal	Condition	Continuity
B305	12	Reclining switch ON (RR operation)	Yes
		Reclining switch OFF	No
	27	Reclining switch ON (FR operation)	Yes
		Reclining switch OFF	No

OK or NG

OK >> Check the condition of the harness and connector.

NG >> Replace power seat switch.

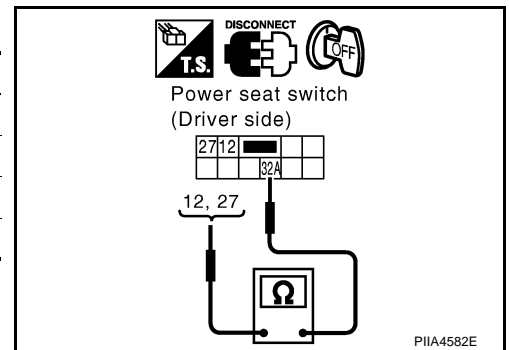

AUTOMATIC DRIVE POSITIONER

AIS003H6

Front Lifting Switch Circuit Check

1. CHECK FUNCTION

④ With CONSULT-II

With "LIFT FR SW-UP, LIFT FR SW-DN" on the DATA MONITOR, operate the front lifting switch to check ON/OFF operation.

Monitor item [OPERATION or UNIT]	Contents	
LIFT FR SW-DN	"ON/OFF"	ON / OFF status judged from the FR lifter switch (DOWN) signal is displayed.
LIFT RR SW-UP	"ON/OFF"	ON / OFF status judged from the RR lifter switch (UP) signal is displayed.

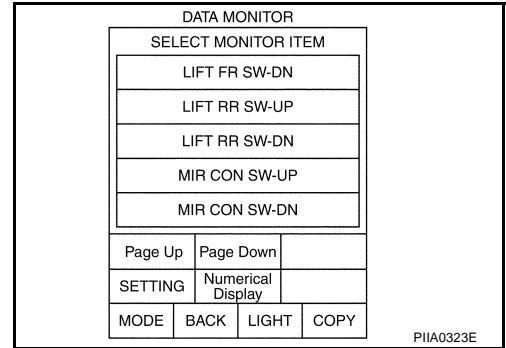

⊗ Without CONSULT-II

1. Turn ignition switch OFF.
2. Check voltage between driver seat control unit connector and ground.

Connector	Terminals (Wire color)		Condition	Voltage (V) (Approx)
	(+)	(-)		
B303	13 (O/B)	Ground	Front lifting switch ON (DOWN operation)	0
			Front lifting switch OFF	Battery voltage
	28 (L/R)		Front lifting switch ON (UP operation)	0
			Front lifting switch OFF	Battery voltage

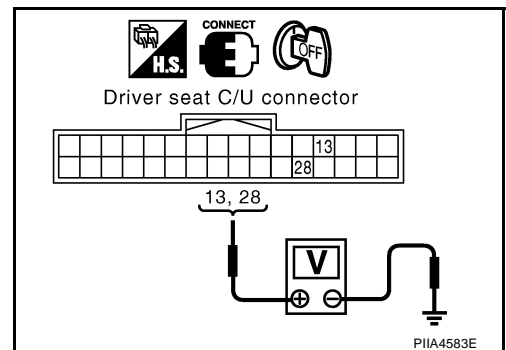

OK or NG

- OK >> Front lifting switch circuit is OK.
- NG >> GO TO 2.

2. CHECK FRONT LIFTING SWITCH CIRCUIT HARNESS CONTINUITY

1. Disconnect driver seat control unit connector and power seat switch connector.
2. Check continuity between driver seat control unit connector B303 terminals 13 (O/B), 28 (L/R) and driver seat switch connector B305 terminals 13 (O/B), 28 (L/R).

- 13 (O/B) – 13 (O/B) : Continuity should exist.**
- 28 (L/R) – 28 (L/R) : Continuity should exist.**

3. Check continuity between driver seat control unit connector B303 terminals 13 (O/B), 28 (L/R) and ground

- 13 (O/B) – Ground : Continuity should not exist.**
- 28 (L/R) – Ground : Continuity should not exist.**

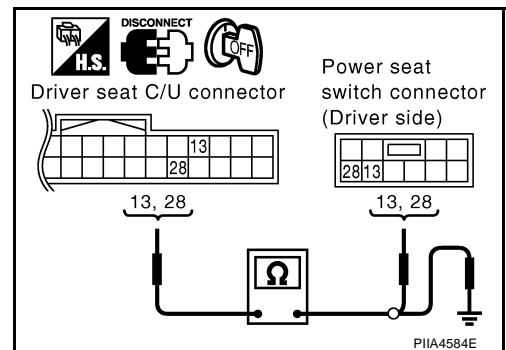

OK or NG

- OK >> GO TO 3.
- NG >> Repair or replace harness between driver seat control unit and power seat switch.

AUTOMATIC DRIVE POSITIONER

3. CHECK FRONT LIFTING SWITCH

Check continuity between driver seat switch as follows.

Connector	Terminals	Condition	Continuity
B305	13	Front lifting switch ON (DOWN operation)	Yes
		Front lifting switch OFF	No
	28	Front lifting switch ON (UP operation)	Yes
		Front lifting switch OFF	No

OK or NG

- OK >> Check the condition of the harness and connector.
- NG >> Replace power seat switch (driver side).

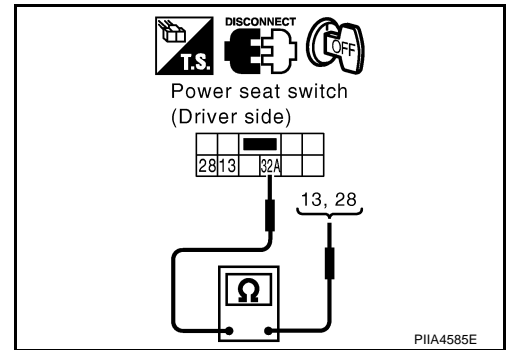

Rear Lifting Switch Circuit Check

1. CHECK FUNCTION

With CONSULT-II

With "LIFT RR SW-UP, LIFT RR SW-DN" on the DATA MONITOR, operate the rear lifting switch to check ON/OFF operation.

Monitor item [OPERATION or UNIT]	Contents
LIFT RR SW-UP	"ON/OFF" Operation (ON)/open (OFF) status judged from the RR lifter switch (UP) signal is displayed.
LIFT RR SW-DN	"ON/OFF" Operation (ON)/open (OFF) status judged from the RR lifter switch (DOWN) signal is displayed.

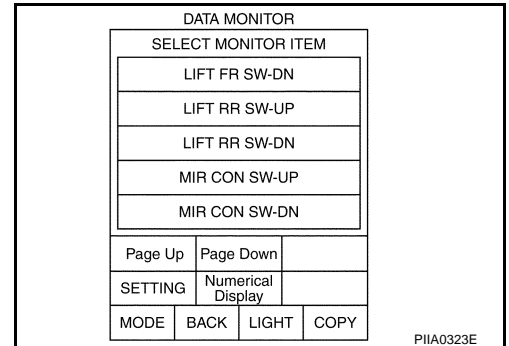

Without CONSULT-II

1. Turn ignition switch OFF.
2. Check voltage between driver seat control unit connector and ground.

Connector	Terminals (Wire color)		Condition	Voltage (V) (Approx)
	(+)	(-)		
B303	14 (Y/R)	Ground	Rear lifting switch ON (DOWN operation)	0
			Rear lifting switch OFF	Battery voltage
	29 (W/G)		Rear lifting switch ON (UP operation)	0
			Rear lifting switch OFF	Battery voltage

OK or NG

- OK >> Rear lifting switch circuit is OK.
- NG >> GO TO 2.

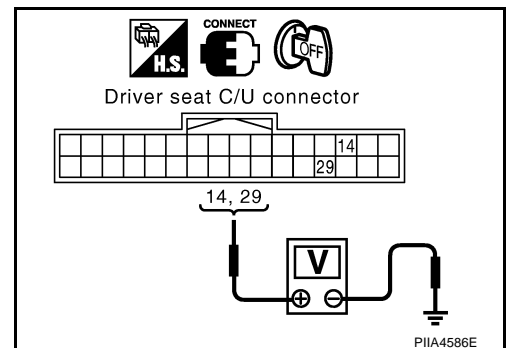

AUTOMATIC DRIVE POSITIONER

2. CHECK POWER SEAT SWITCH CIRCUIT HARNESS CONTINUITY

1. Disconnect driver seat control unit connector and power seat switch connector.
2. Check continuity between driver seat control unit connector B303 terminals 14 (Y/R), 29 (W/G) and power seat switch connector B305 terminals 14 (Y/R), 29 (W/G).

14 (Y/R) – 14 (Y/R) : Continuity should exist.
29 (W/G) – 29 (W/G) : Continuity should exist.

3. Check continuity between driver seat control unit connector B303 terminals 14 (Y/R), 29 (W/G) and ground.

14 (Y/R) – Ground : Continuity should not exist.
29 (W/G) – Ground : Continuity should not exist.

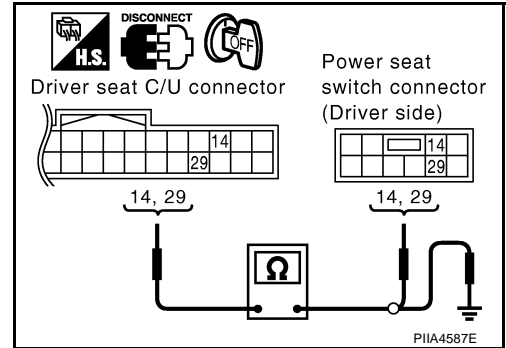

OK or NG

OK >> GO TO 3.

NG >> Repair or replace harness between driver seat control unit and power seat switch.

3. CHECK REAR LIFTING SWITCH

Check continuity between driver seat switch as follows.

Connector	Terminals	Condition	Continuity
B305	14	Rear lifting switch ON (DOWN operation)	Yes
		Rear lifting switch OFF	No
	29	Rear lifting switch ON (UP operation)	Yes
		Rear lifting switch OFF	No

OK or NG

OK >> Check the condition of the harness and connector.

NG >> Replace power seat switch.

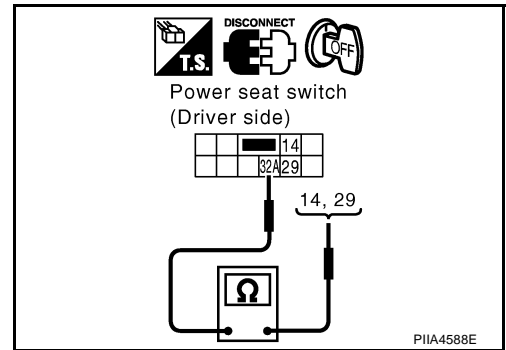

AIS003HB

Power Seat Switch Ground Circuit Check

1. CHECK POWER SEAT SWITCH GROUND CIRCUIT

Check continuity between power seat switch connector B305 terminal 32A (B/W) and ground.

32A (B/W) – Ground : Continuity should exist.

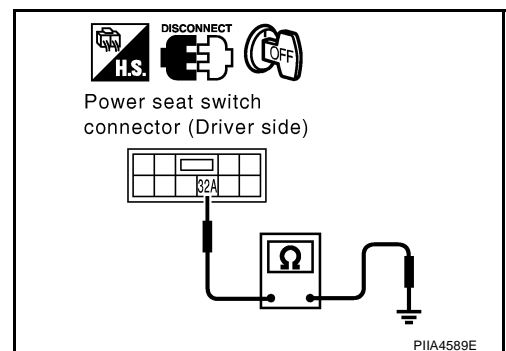

OK or NG

OK >> Check the condition of the harness and connector.

NG >> Repair or replace harness between power seat switch and ground.

AUTOMATIC DRIVE POSITIONER

AIS003H9

Pedal Adjusting Switch Circuit Check

1. CHECK FUNCTION

With CONSULT-II

With "PEDAL SW-FR, PEDAL SW-RR" on the DATA MONITOR, operate the pedal adjusting switch to check ON/OFF operation.

Monitor item [OPERATION or UNIT]		Contents
PEDAL SW-FR	"ON/OFF"	Operation (ON)/open (OFF) status judged from the pedal adjusting switch (FR) signal is displayed.
PEDAL SW-RR	"ON/OFF"	Operation (ON)/open (OFF) status judged from the pedal adjusting switch (RR) signal is displayed.

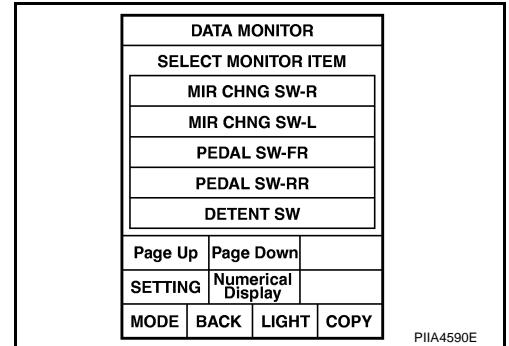

Without CONSULT-II

- Turn ignition switch OFF.
- Check voltage between driver seat control unit connector and ground.

Connector	Terminals (Wire color)		Condition	Voltage (V) (Approx)
	(+)	(-)		
B303	15 (G/R)	Ground	Pedal adjusting switch ON (RR operation)	0
			Pedal adjusting switch OFF	Battery voltage
	30 (W/L)		Pedal adjusting switch ON (FR operation)	0
			Pedal adjusting switch OFF	Battery voltage

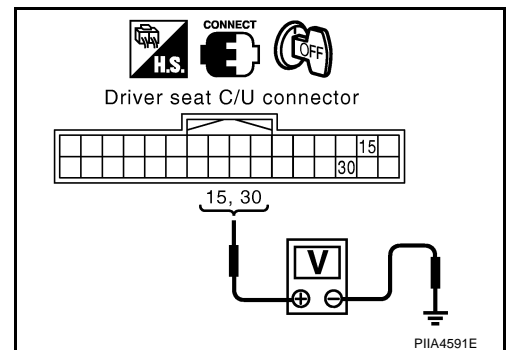

OK or NG

- OK >> Pedal adjusting switch circuit is OK.
 NG >> GO TO 2.

2. CHECK PEDAL ADJUSTING SWITCH CIRCUIT HARNESS CONTINUITY

- Disconnect driver seat control unit connector and pedal adjusting switch connector.
- Check continuity between driver seat control unit connector B303 terminals 15 (G/R), 30 (W/L) and pedal adjusting switch connector B306 terminals 15 (G/R), 30 (W/L).

- 15 (G/R) – 15 (G/R) : Continuity should exist.**
30 (W/L) – 30 (W/L) : Continuity should exist.

- Check continuity between driver seat control unit connector B303 terminals 15 (G/R), 30 (W/L) and ground.

- 15 (G/R) – Ground : Continuity should not exist.**
30 (W/L) – Ground : Continuity should not exist.

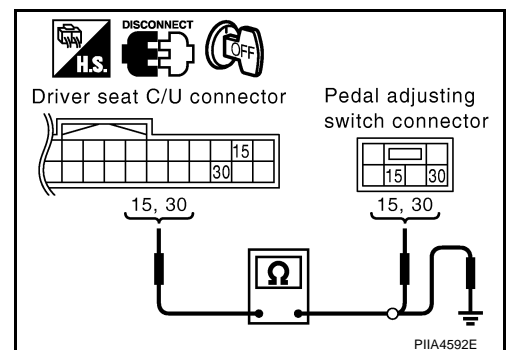

OK or NG

- OK >> GO TO 3.
 NG >> Repair or replace harness between driver seat control unit and pedal adjusting switch.

AUTOMATIC DRIVE POSITIONER

3. CHECK PEDAL ADJUSTING SWITCH

Check continuity between pedal adjust switch as follows.

Connector	Terminals		Condition	Continuity
B306	15	48C	Pedal adjusting switch ON (RR operation)	Yes
			Pedal adjusting switch OFF	No
	30	48C	Pedal adjusting switch ON (FR operation)	Yes
			Pedal adjusting switch OFF	No

OK or NG

OK >> GO TO 4.

NG >> Replace pedal adjusting switch.

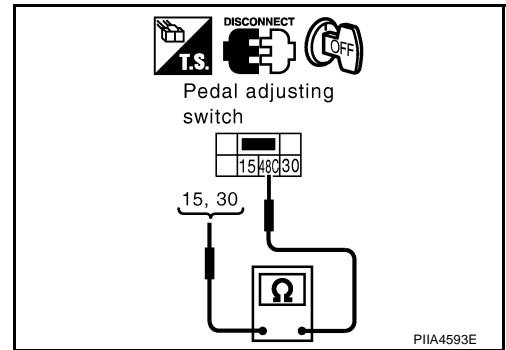

4. CHECK PEDAL ADJUSTING SWITCH GROUND CIRCUIT

Check continuity between pedal adjusting switch connector B306 terminal 48C (B) and ground.

48C (B) – Ground : Continuity should exist.

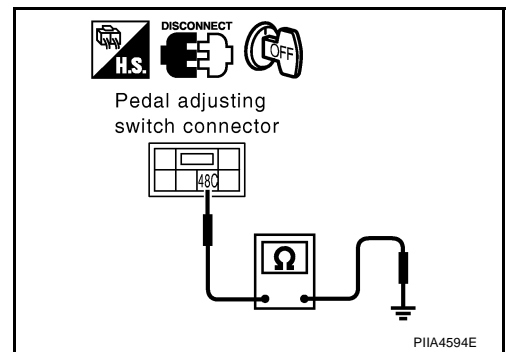

OK or NG

OK >> Check the condition of the harness and connector.

NG >> Replace or replace harness between pedal adjusting switch and ground.

AUTOMATIC DRIVE POSITIONER

Door Mirror Remote Control Switch (Changeover Switch) Circuit Check

AI5003HG

1. CHECK FUNCTION

With CONSULT-II

Check the operation on "MIR CHNG SW – R" or "MIR CHNG SW–L" in the DATA MONITOR.

Monitor item [OPERATION or UNIT]		Contents
MIR CHNG SW-R	"ON/OFF"	ON/OFF status judged from the door mirror remote control switch (switching to RIGHT) signal is displayed.
MIR CHNG SW-L	"ON/OFF"	ON/OFF status judged from the door mirror remote control switch (switching to LEFT) signal is displayed.

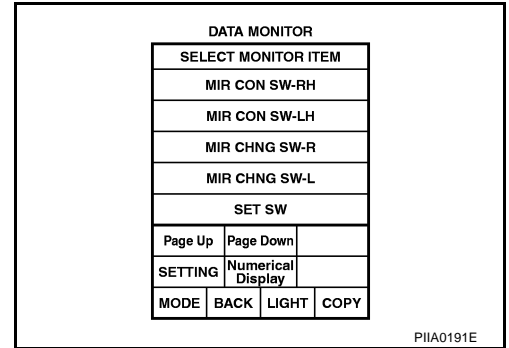

Without CONSULT-II

- Turn ignition switch ACC.
- Check voltage between automatic drive positioner control unit connector and ground.

Connector	Terminals (Wire color)		Condition	Voltage (V) (Approx)
	(+)	(-)		
M19	2 (L/W)	Ground	Changeover switch RIGHT position	0
			Changeover switch neutral position	5
	18 (BR/Y)		Changeover switch LEFT position	0
			Changeover switch neutral position	5

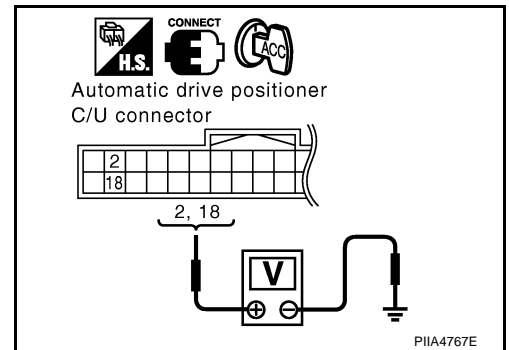

OK or NG

- OK >> Door mirror remote control switch (changeover switch) is OK.
 NG >> GO TO 2.

2. CHECK DOOR MIRROR REMOTE CONTROL SWITCH CIRCUIT HARNESS CONTINUITY

- Turn ignition switch OFF.
- Disconnect automatic drive positioner control unit and door mirror remote control switch connector.
- Check continuity between automatic drive positioner control unit connector M19 terminal 2 (L/W), 18 (BR/Y) and door mirror remote control switch connector M66 terminal 3 (L/W), 2 (BR/Y).

2 (L/W) – 3 (L/W) :Continuity should exist.
18 (BR/Y) – 2 (BR/Y) :Continuity should exist.

- Check continuity between automatic drive positioner control unit connector M19 terminal 2 (L/W), 18 (BR/Y) and ground.

2 (L/W) – Ground :Continuity should not exist.
18 (BR/Y) – Ground :Continuity should not exist.

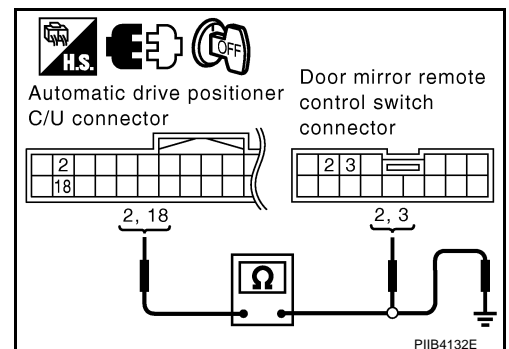

OK or NG

- OK >> GO TO 3.
 NG >> Repair or replace harness between automatic drive positioner control unit and door remote control switch.

AUTOMATIC DRIVE POSITIONER

3. CHECK DOOR MIRROR REMOTE CONTROL SWITCH (CHANGEOVER SWITCH)

Check continuity between door mirror remote control switch as follows.

Connector	Terminals		Condition	Continuity
M66	3	13	Changeover switch RIGHT position	Yes
			Changeover switch neutral position	No
	2		Changeover switch LEFT position	Yes
			Changeover switch neutral position	No

OK or NG

- OK >> Check the condition of the harness and the connector.
- NG >> Replace door mirror remote control switch.

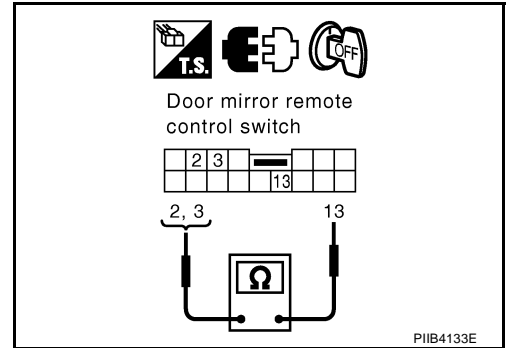

Door Mirror Remote Control Switch (Mirror Switch) Circuit Check

AIS003HH

1. CHECK DOOR MIRROR REMOTE CONTROL SWITCH(MIRROR SWITCH) SIGNAL

With CONSULT-II

Check the operation on "MIR CON SW-UP/DN" and "MIR CON SW-RH/LH" in the DATA MONITOR.

Monitor item [OPERATION or UNIT]	Contents
MIR CON SW -UP	"ON/OFF" ON/OFF status judged from the door mirror remote control switch (UP) signal is displayed.
MIR CON SW -DN	"ON/OFF" ON/OFF status judged from the door mirror remote control switch (DOWN) signal is displayed.
MIR CON SW -RH	"ON/OFF" ON/OFF status judged from the door mirror remote control switch (RIGHT) signal is displayed.
MIR CON SW -LH	"ON/OFF" ON/OFF status judged from the door mirror remote control switch (LEFT) signal is displayed.

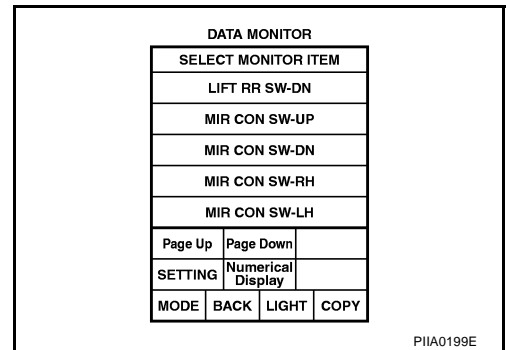

Without CONSULT-II

1. Turn ignition switch ACC.
2. Check voltage between automatic drive positioner control unit connector and ground.

Connector	Terminals (Wire color)		Condition	Voltage (V) (Approx)
	(+)	(-)		
M19	3 (Y/B)	Ground	Mirror switch UP operation	0
			Mirror switch neutral position	5
	4 (V/W)		Mirror switch LEFT operation	0
			Mirror switch neutral position	5
	19 (L/O)		Mirror switch DOWN operation	0
			Mirror switch neutral position	5
	20 (V)		Mirror switch RIGHT operation	0
			Mirror switch neutral position	5

OK or NG

- OK >> Door mirror remote control switch (mirror switch) circuit is OK.
- NG >> GO TO 2.

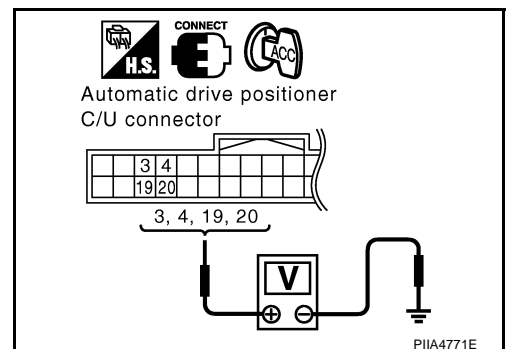

AUTOMATIC DRIVE POSITIONER

2. CHECK HARNESS CONTINUITY

1. Turn ignition switch OFF.
2. Disconnect automatic drive positioner control unit and door mirror remote control switch connector.
3. Check continuity between automatic drive positioner control unit connector M19 terminal 3 (Y/B), 4 (V/W), 19 (L/O), 20 (V) and door mirror remote control switch connector M66 terminal 4 (V), 5 (V/W), 6 (Y/B), 14 (L/O).

3 (Y/B) – 6 (Y/B) :Continuity should exist.
4 (V/W) – 5 (V/W) :Continuity should exist.
19 (L/O) – 14 (L/O) :Continuity should exist.
20 (V) – 4 (V) :Continuity should exist.

4. Check continuity between automatic drive positioner control unit connector M19 terminal 3 (Y/B), 4 (V/W), 19 (L/O), 20 (V) and ground.

3 (Y/B) – Ground :Continuity should not exist.
4 (V/W) – Ground :Continuity should not exist.
19 (L/O) – Ground :Continuity should not exist.
20 (V) – Ground :Continuity should not exist.

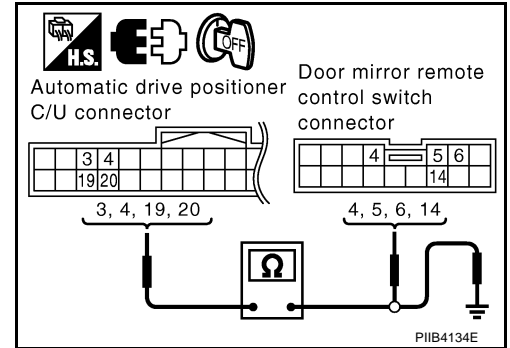

OK or NG

OK >> GO TO 3.

NG >> Repair or replace harness between automatic drive positioner control unit and door mirror remote control switch.

3. CHECK DOOR MIRROR REMOTE CONTROL SWITCH (MIRROR SWITCH)

Check continuity between door mirror remote control switch as follows.

Connector	Terminals	Switch condition	Continuity
M66	4	Mirror switch RIGHT operation	Yes
		Mirror switch neutral position	No
	5	Mirror switch LEFT operation	Yes
		Mirror switch neutral position	No
	6	Mirror switch UP operation	Yes
		Mirror switch neutral position	No
	14	Mirror switch DOWN operation	Yes
		Mirror switch neutral position	No

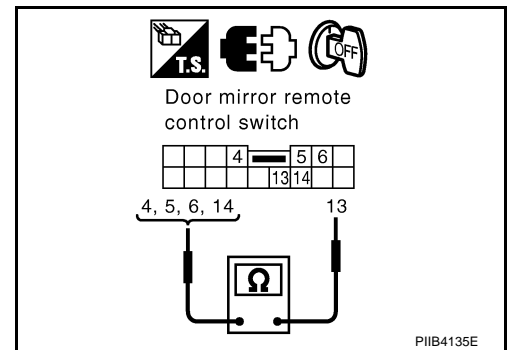

OK or NG

OK >> Check the condition of the harness and connector.

NG >> Replace door mirror remote control switch.

AUTOMATIC DRIVE POSITIONER

Door Mirror Remote Control Switch Ground Circuit Check

AIS003HU

1. CHECK DOOR MIRROR REMOTE CONTROL SWITCH GROUND CIRCUIT

Check continuity between door mirror remote control switch connector M66 terminal 13 (B) and ground.

13 (B) - Ground : Continuity should exist.

OK or NG

- OK >> Check the condition of the harness and the connector.
- NG >> Repair or replace harness between door mirror remote control switch and ground.

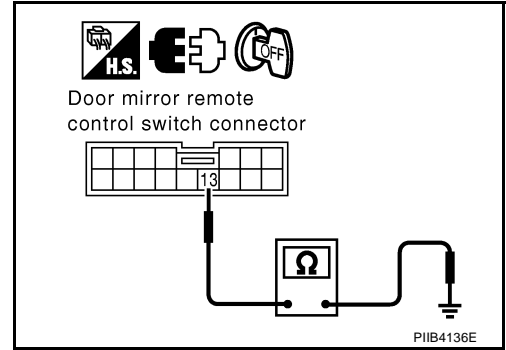

Seat Memory Switch Circuit Check

AIS003H3

1. CHECK FUNCTION

With CONSULT-II

With “SET SW, MEMORY SW1, MEMORY SW2”, “SET SW” on the DATA MONITOR, operate the switch to check ON/OFF operation.

Monitor item [OPERATION or UNIT]		Contents
MEMORY SW1	“ON/OFF”	ON/OFF status judged from the seat memory switch 1 signal is displayed.
MEMORY SW2	“ON/OFF”	ON/OFF status judged from the seat memory switch 2 signal is displayed.
SET SW	“ON/OFF”	ON/OFF status judged from the setting switch signal is displayed.

DATA MONITOR

MONITOR			
SLIDE SW-FR		OFF	
SLIDE SW-RR		OFF	
RECLN SW-FR		OFF	
RECLN SW-RR		OFF	
LIFT FR SW-UP		OFF	
LIFT FR SW-DN		OFF	
LIFT RR SW-UP		OFF	
LIFT RR SW-DN		OFF	
SET SW		OFF	

Page Down			
RECORD			
MODE	BACK	LIGHT	COPY

DATA MONITOR

MONITOR			
TELESCO SW-FR		OFF	
TELESCO SW-RR		OFF	
TILT SW-UP		OFF	
TILT SW-DOWN		OFF	
MEMORY SW 1		OFF	
MEMORY SW 2		OFF	
CANCEL SW		OFF	
DOOR SW-DR		OFF	
VHCL SPEED SE		<7km/	

Page Up		Page Down	
RECORD			
MODE	BACK	LIGHT	COPY

PIIA0309E

Without CONSULT-II

GO TO 2.

OK or NG

- OK >> Seat memory switch circuit is OK.
- NG >> GO TO 2.

AUTOMATIC DRIVE POSITIONER

2. CHECK SEAT MEMORY SWITCH

1. Turn ignition switch OFF.
2. Disconnect seat memory switch connector.
3. Check continuity between seat memory switch as follows.

Connector	Terminal	Condition	Continuity
D3	1	Memory switch 1 ON	Yes.
		Memory switch 1: OFF	No.
	2	Memory switch 2: ON	Yes.
		Memory switch 2: OFF	No.
	3	Set switch: ON	Yes.
		Set switch: OFF	No.

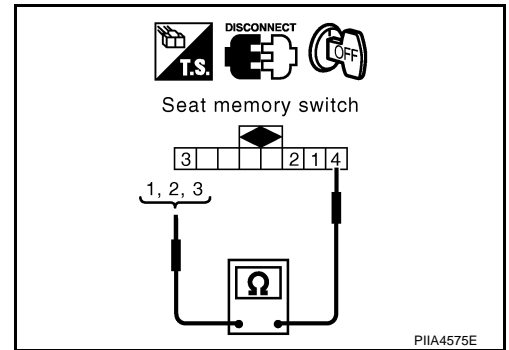

OK or NG

- OK >> GO TO 3.
 NG >> Replace seat memory switch.

3. CHECK HARNESS CONTINUITY

1. Disconnect automatic drive positioner control unit connector.
2. Check continuity between automatic drive positioner control unit connector M19 terminals 9 (LG/B), 24 (R/Y), 25 (P/L) and seat memory switch connector D3 terminals 1 (LG/B), 2 (P/L), 3 (R/Y).

- 9 (LG/B) – 1 (LG/B) : Continuity should exist.**
24 (R/Y) – 3 (R/Y) : Continuity should exist.
25 (P/L) – 2 (P/L) : Continuity should exist.

3. Check continuity between automatic drive positioner control unit connector M19 terminals 9 (LG/B), 24 (R/Y), 25 (P/L) and ground.

- 9 (LG/B) – Ground : Continuity should not exist.**
24 (R/Y) – Ground : Continuity should not exist.
25 (P/L) – Ground : Continuity should not exist.

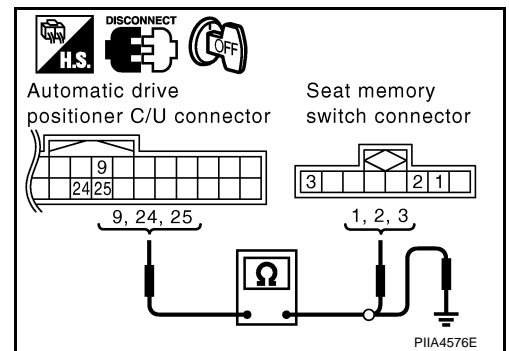

OK or NG

- OK >> GO TO 4.
 NG >> Repair or replace harness between automatic drive positioner control unit and seat memory switch.

4. CHECK SEAT MEMORY SWITCH GROUND CIRCUIT

Check continuity between seat memory switch D3 terminal 4 (B) and ground.

- 4 (B) – Ground : Continuity should exist.**

OK or NG

- OK >> Replace automatic drive positioner control unit.
 NG >> Repair or replace harness between seat memory switch and ground.

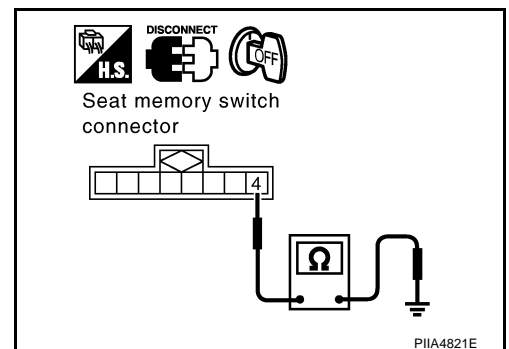

AUTOMATIC DRIVE POSITIONER

AIS003HA

Seat Memory Indicator Lamp Circuit Check

1. CHECK FUNCTION

④ With CONSULT-II

With "MEMORY SW INDCTR" in ACTIVE TEST, check operation.

Test item	Description
MEMORY SW INDCTR	The memory switch indicator is lit by receiving the drive signal.

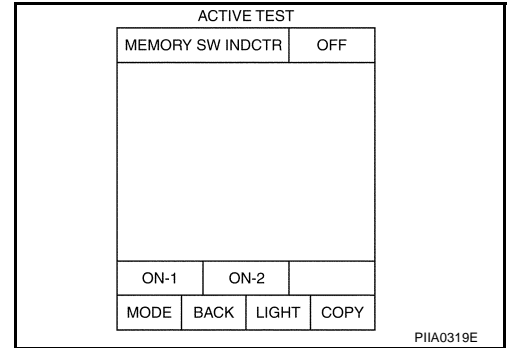

⊗ Without CONSULT-II

GO TO 2.

OK or NG

OK >> Seat memory indicator lamp circuit is OK.

NG >> GO TO 2.

2. CHECK SEAT MEMORY SWITCH POWER SUPPLY CIRCUIT

1. Turn ignition switch OFF.
2. Disconnect seat memory switch connector.
3. Check voltage between seat memory switch connector D3 terminal 5 (Y/R) and ground.

5 (Y/R) – Ground : Battery voltage

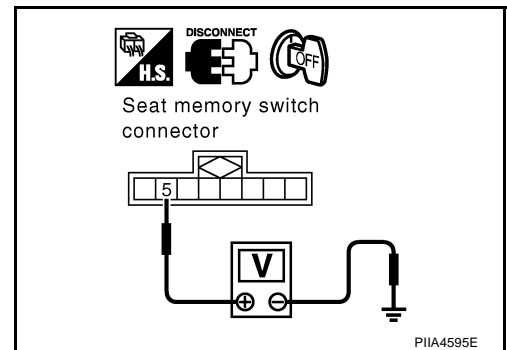

OK or NG

OK >> GO TO 3.

NG >> Repair or replace harness between fuse block (J/B) and seat memory switch.

AUTOMATIC DRIVE POSITIONER

3. CHECK SEAT MEMORY INDICATOR CIRCUIT HARNESS CONTINUITY

1. Disconnect automatic drive positioner control unit connector.
2. Check continuity between automatic drive positioner control unit connector M19 terminals 12 (GR/L), 13 (Y/G) and seat memory switch connector D3 terminals 6 (GR/L), 7 (Y/G).

12 (GR/L) – 6 (GR/L) : Continuity should exist.
13 (Y/G) – 7 (Y/G) : Continuity should exist.

3. Check continuity between automatic drive positioner control unit connector M19 terminals 12 (GR/L), 13 (Y/G) and ground.

12 (GR/L) – Ground : Continuity should not exist.
13 (Y/G) – Ground : Continuity should not exist.

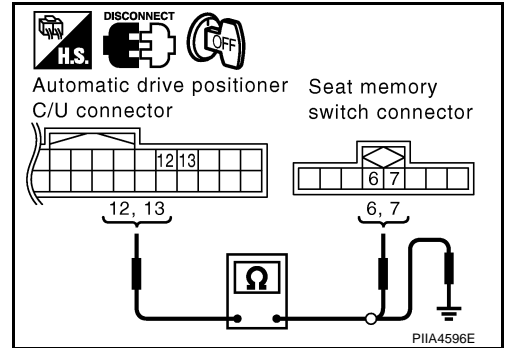

OK or NG

OK >> GO TO 4.

NG >> Repair or replace harness between automatic drive positioner control unit and memory switch.

4. CHECK SEAT MEMORY SWITCH INDICATOR SIGNAL

Check voltage between automatic drive positioner control unit connector M19 terminals 12 (GR/L), 13 (Y/G) and ground.

12 (GR/L) – Ground : Battery voltage
13 (Y/G) – Ground : Battery voltage

OK or NG

OK >> Replace automatic drive positioner control unit.

NG >> Replace seat memory switch.

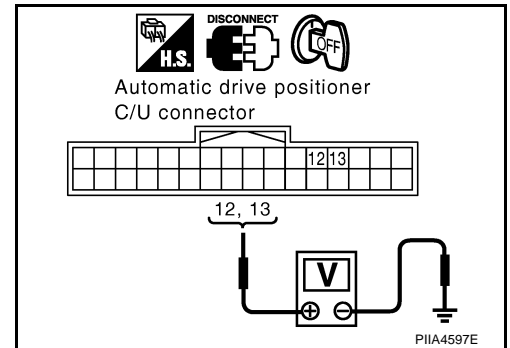

Door Mirror Sensor Power Supply and Ground Circuit Check

AIS003HT

1. CHECK DOOR MIRROR SENSOR CIRCUIT HARNESS CONTINUITY

1. Turn ignition switch OFF.
2. Disconnect automatic drive positioner control unit connector and door mirror (driver side and passenger side) connector.
3. Check continuity between automatic drive positioner control unit connector M20 terminal 33 (W/L), 41 (Y) and door mirror (driver side) connector D2 (driver side) D32 (passenger side) terminal 3 (W/L), 2 (Y).

33 (W/L) - 3 (W/L) : Continuity should exist.
41 (Y) - 2 (Y) : Continuity should exist.

4. Check continuity between automatic drive positioner control unit connector M20 terminal 33 (W/L), 41 (Y) and ground.

33 (W/L) - Ground : Continuity should not exist.
41 (Y) - Ground : Continuity should not exist.

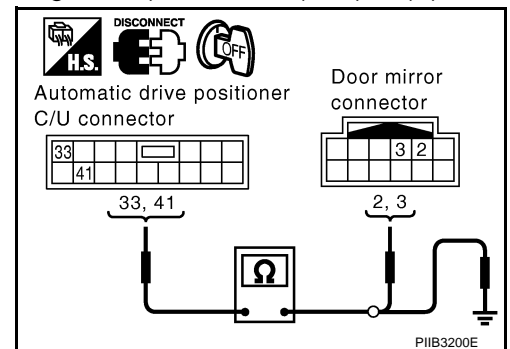

OK or NG

OK >> GO TO 2.

NG >> Repair or replace harness between automatic drive positioner control unit and door mirror (driver side and passenger side)

AUTOMATIC DRIVE POSITIONER

2. CHECK MIRROR SENSOR POWER SUPPLY

1. Connector automatic drive positioner control unit connector and door mirror (driver side).
2. Turn ignition switch ACC.
3. Check voltage between automatic drive positioner control unit connector M20 terminal 33 (W/L) and ground.

33 (W/L) - Ground : Approx. 5V

OK or NG

- OK >> GO OT 3.
 NG >> Replace automatic drive positioner control unit.

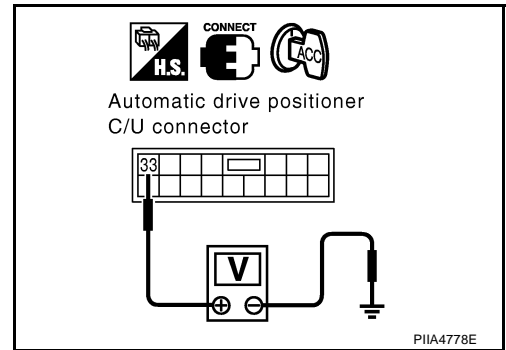

3. CHECK MIRROR SENSOR GROUND CIRCUIT

1. Turn ignition switch OFF.
2. Check continuity between automatic drive positioner control unit connector M20 terminal 41 (Y) and ground.

41 (Y) - Ground : Continuity should exist.

OK or NG

- OK >> Check the condition of the harness and connector.
 NG >> Replace automatic drive positioner control unit.

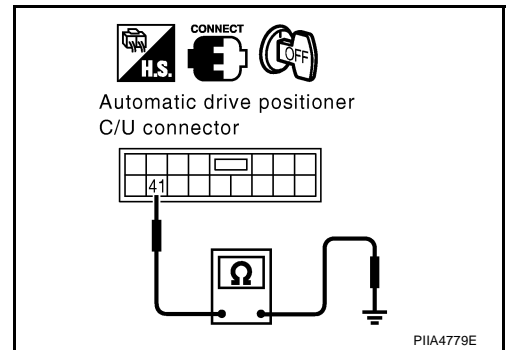

Detention Switch Circuit Check

1. CHECK FUNCTION

With CONSULT-II

Check that when the CVT selector lever is in P position, "DETENT SW" on the DATA MONITOR becomes OFF.

Monitor item [OPERATION or UNIT]		Contents
DETENT SW	"ON/ OFF"	The selector lever position "P position (OFF)/other than P position (ON)" judged from the detente switch signal is displayed.

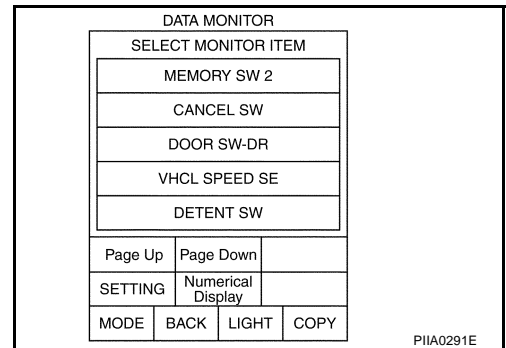

Without CONSULT-II

GO TO 2.

OK or NG

- OK >> Detention switch circuit is OK.
 NG >> GO TO 2.

AUTOMATIC DRIVE POSITIONER

2. CHECK DETENTION SWITCH POWER SUPPLY

1. Key is inserted in ignition key cylinder.
2. Disconnect CVT device [detention switch (key)] connector.
3. Check voltage between CVT device [detention switch (key)] connector M57 terminal 5 (B/R) and ground.

5 (B/R) – Ground : Battery voltage.

OK or NG

- OK >> GO TO 5.
NG >> ● GO TO 3. (Without intelligent key)
● GO TO 4. (With intelligent key)

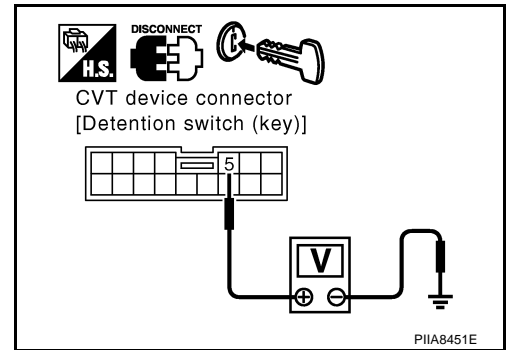

3. CHECK DETENTION SWITCH HARNESS (WITHOUT INTELLIGENT KEY)

1. Turn ignition switch OFF.
2. Disconnect CVT device [detention switch (key)] connector and key switch connector.
3. Check continuity between CVT device [detention switch (key)] connector M57 terminal 5 (B/R) and key switch connector M28 terminal 4 (B/R).

5 (B/R) – 4 (B/R) : Continuity should exist.

4. Check continuity between CVT device [detention switch (key)] connector M57 terminal 5 (B/R) and ground.

5 (B/R) – Ground : Continuity should not exist.

OK or NG

- OK >> Check the condition of the harness and connector.
NG >> Repair or replace harness between CVT device [detention switch (key)] and key switch.

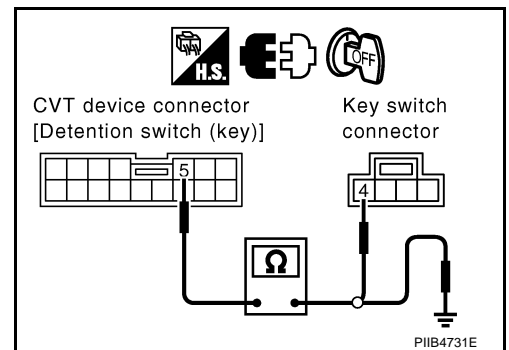

4. CHECK DETENTION SWITCH HARNESS (WITH INTELLIGENT KEY)

1. Turn ignition switch OFF.
2. Disconnect CVT device [detention switch (key)] connector and key switch and ignition knob switch connector.
3. Check continuity between CVT device [detention switch (key)] connector M57 terminal 5 (B/Y) and key switch and ignition knob switch connector M118 terminal 4 (B/R).

5 (B/Y) – 4 (B/R) : Continuity should exist.

4. Check continuity between CVT device [detention switch (key)] connector M57 terminal 5 (B/Y) and ground

5 (B/Y) – Ground : Continuity should not exist.

OK or NG

- OK >> Check the condition of the harness and connector.
NG >> Repair or replace harness between CVT device [detention switch (key)] and key switch and ignition switch.

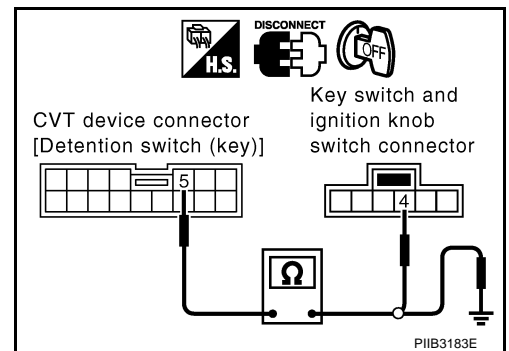

AUTOMATIC DRIVE POSITIONER

5. CHECK DETENTION SWITCH

Check continuity between detection switch as follows.

Terminals		Condition	Continuity
5	6	P-position	Yes.
		Other than P-position	No.

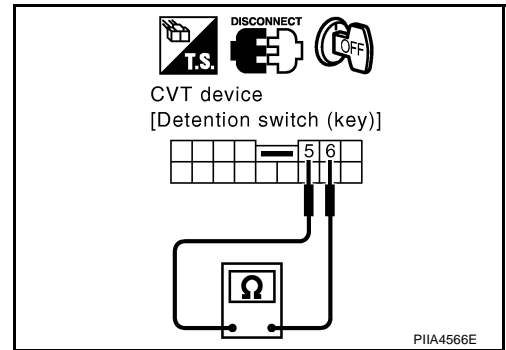

OK or NG

OK >> GO TO 6.

NG >> Replace CVT device [detention switch (key)].

6. CHECK DETENTION SWITCH SIGNAL CIRCUIT HARNESS CONTINUITY

1. Disconnect driver seat control unit connector.
2. Check continuity between driver seat control unit connector B303 terminal 21 (R/L) and CVT device [detention switch (key)] connector M57 terminal 6 (L).

21 (R/L) – 6 (L) : Continuity should exist.

3. Check continuity between driver seat control unit connector B303 terminal 21 (R/L) and ground.

21 (R/L) – Ground : Continuity should not exist.

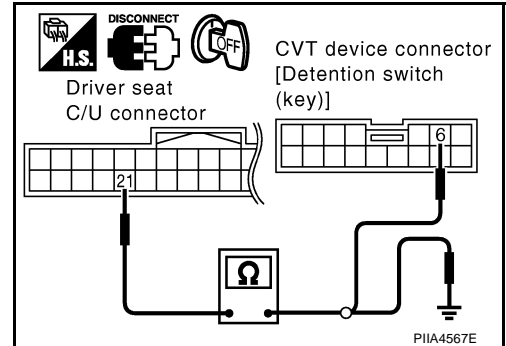

OK or NG

OK >> Replace driver seat control unit.

NG >> Repair or replace harness between automatic drive positioner control unit and CVT device [detention switch (key)].

Key Switch Circuit Check (Without Intelligent Key)

AIS003H1

1. CHECK KEY SWITCH AND KEY LOCK SOLENOID

With CONSULT-II

Touch "BCM". With "IGN KEY SW" on the DATA MONITOR, Check ON/OFF operation.

Monitor item [OPERATION or UNIT]	Contents	
IGN KEY SW*	"ON/OFF"	Key inserted (ON)/key removed (OFF) status judged from the key-in detection switch is displayed.

*:Refer to [SE-45. "DATA MONITOR"](#).

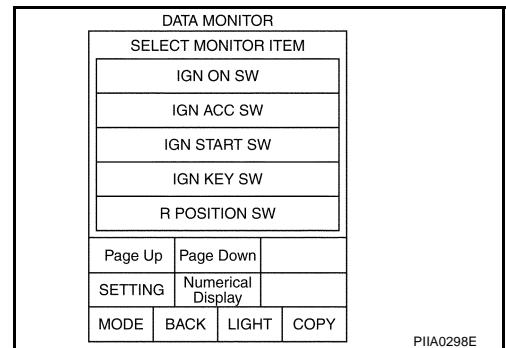

Without CONSULT-II

GO TO 2.

OK or NG

OK >> Key switch circuit is OK.

NG >> GO TO 2.

AUTOMATIC DRIVE POSITIONER

2. KEY SWITCH POWER SUPPLY CIRCUIT CHECK

1. Turn ignition switch OFF.
2. Check voltage between key switch connector M28 terminal 3 (Y/R) and ground.

3 (Y/R) – Ground : Battery voltage.

OK or NG

- OK >> GO TO 3.
 NG >> Check harness between key switch and fuse.

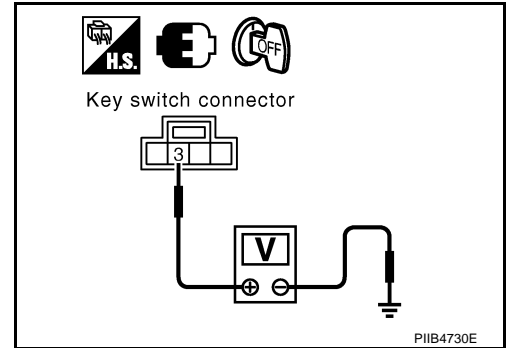

3. CHECK KEY SWITCH

1. Disconnect key switch connector.
2. Check continuity between key switch as follows.

Connector	Terminals	Condition	Continuity
M28	3 4	Key is inserted in ignition key cylinder.	Yes
		Key is removed from ignition key cylinder.	No

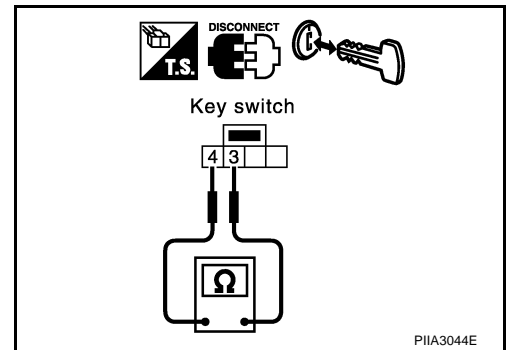

OK or NG

- OK >> GO TO 4.
 NG >> Replace key switch.

4. CHECK HARNESS CONTINUITY

1. Check continuity between BCM connector M34 terminal 37 (B/R) and key switch connector M28 terminal 4 (B/R).

37 (B/R) – 4 (B/R) : Continuity should exist.

2. Check continuity between BCM connector M34 terminal 37 (B/R) and ground.

37 (B/R) – Ground : Continuity should not exist.

OK or NG

- OK >> Key switch and key lock solenoid circuit is OK.
 NG >> Repair or replace harness between key switch and BCM.

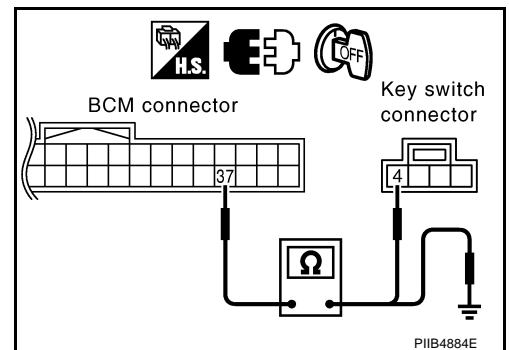

AUTOMATIC DRIVE POSITIONER

AIS0066P

Key Switch Circuit Check (With Intelligent Key)

1. CHECK KEY SWITCH

With CONSULT-II

Touch "BCM". With "IGN KEY SW" on the DATA MONITOR, Check ON/OFF operation.

Monitor item [OPERATION or UNIT]	Contents	
IGN KEY SW*	"ON/OFF"	Key inserted (ON)/key removed (OFF) status judged from the key-in detection switch is displayed.

*:Refer to [SE-45. "DATA MONITOR"](#) .

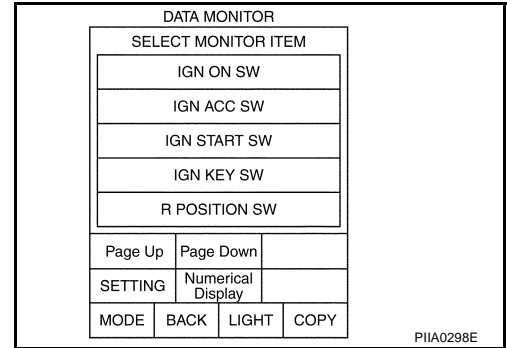

Without CONSULT-II

GO TO 2.

OK or NG

- OK >> Key switch circuit is OK.
- NG >> GO TO 2.

2. KEY SWITCH POWER SUPPLY CIRCUIT CHECK

- Turn ignition switch OFF.
- Check voltage between key switch and ignition knob switch connector M118 terminal 3 (G/Y) and ground.

3 (G/Y) – Ground : Battery voltage.

OK or NG

- OK >> GO TO 3.
- NG >> Check harness between key switch and ignition knob switch and fuse.

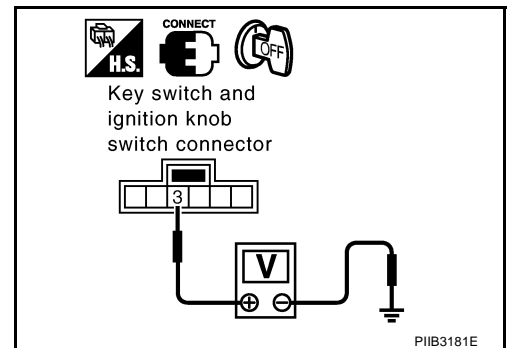

3. CHECK KEY SWITCH

- Disconnect key switch and ignition knob switch connector.
- Check continuity between key switch and ignition knob switch as follows.

Connector	Terminals		Condition	Continuity
M118	3	4	Key is inserted in ignition key cylinder.	Yes
			Key is removed from ignition key cylinder.	No

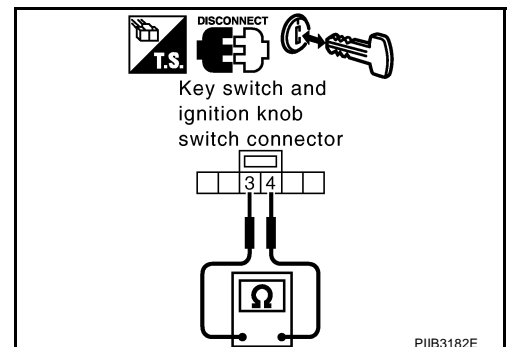

OK or NG

- OK >> GO TO 4.
- NG >> Replace key switch and ignition knob switch.

AUTOMATIC DRIVE POSITIONER

4. CHECK HARNESS CONTINUITY

1. Check continuity between BCM connector M34 terminal 37 (B/R) and key switch and ignition knob switch connector M118 terminal 4 (B/R).

37 (B/R) – 4 (B/R) : Continuity should exist.

2. Check continuity between BCM connector M34 terminal 37 (B/R) and ground.

37 (B/R) – Ground : Continuity should not exist.

OK or NG

OK >> Key switch circuit is OK.

NG >> Repair or replace harness between key switch and ignition knob switch and BCM.

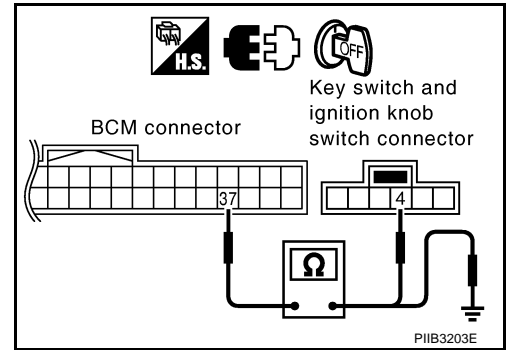

A
B
C
D
E
F
G
H
SE
J
K
L
M

AUTOMATIC DRIVE POSITIONER

AIS003HB

UART Communication Line Circuit Check

1. CHECK UART LINE INPUT/OUTPUT SIGNAL 1

1. Turn ignition switch OFF.
2. Check signal between driver seat control unit connector and ground, with oscilloscope.

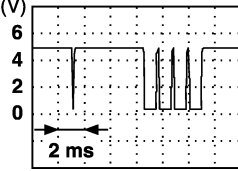
Connector	Terminals (Wire color)		Condition	Signal (Reference value)
	(+)	(-)		
B303	17 (Y/L)	Ground	Pedal adjusting switch ON (FR or RR operation)	 <p>(V) 6 4 2 0</p> <p>2 ms</p> <p>PIIA4814E</p>

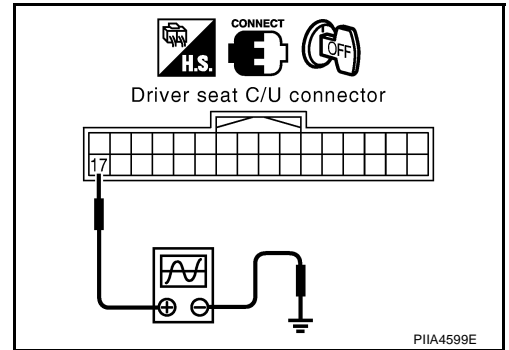

OK or NG

OK >> GO TO 2.

NG >> Check the following.

- When voltage waveform does not appear with a constant voltage (approx. 5V), replace driver seat control unit.
- When voltage waveform does not appear with a constant voltage (approx. 0V), replace automatic driver seat control unit.

2. CHECK UART LINE INPUT/OUTPUT SIGNAL 2

Check signal between automatic driver positioner control unit connector ground, with oscilloscope.

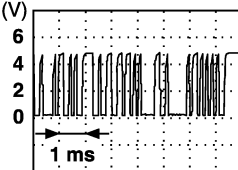
Connector	Terminals (Wire color)		Condition	Signal (Reference value)
	(+)	(-)		
M19	10 (R)	Ground	Pedal adjusting switch ON (FR or RR operation)	 <p>(V) 6 4 2 0</p> <p>1 ms</p> <p>PIIA4813E</p>

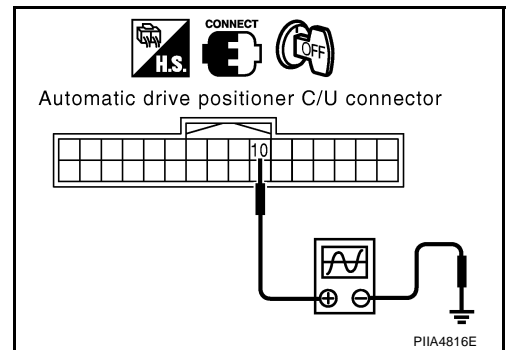

OK or NG

OK >> GO TO 3.

NG >> Check the following.

- When voltage waveform does not appear with a constant voltage (approx. 5V), replace automatic drive positioner control unit.
- When voltage waveform does not appear with a constant voltage (approx. 0V), replace driver seat control unit.

AUTOMATIC DRIVE POSITIONER

3. CHECK UART LINE HERNESS

1. Disconnect driver seat control unit connector and automatic drive positioner control unit connector.
2. Check continuity between driver seat control unit connector B303 terminal 1 (Y/W), 17 (Y/L) and automatic drive positioner connector M19 terminal 10 (R), 26 (R/G).

1 (Y/W) – 10 (R) : Continuity should exist.

17 (Y/L) – 26 (R/G) : Continuity should exist.

3. Check continuity between driver seat control unit connector B303 terminal 1 (Y/W), 17 (Y/L) and ground.

1 (Y/W) – Ground : Continuity should not exist.

17 (Y/L) – Ground : Continuity should not exist.

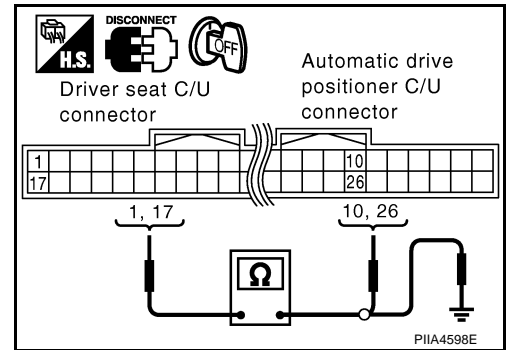

OK or NG

OK >> GO TO 4.

NG >> Repair or replace harness between driver seat control unit and automatic drive positioner control unit.

4. CHECK DRIVER SEAT CONTROL UNIT

Does the automatic drive positioner operate, when the driver control unit exchanged?

OK or NG

OK >> Replace automatic drive positioner control unit.

NG >> Replace driver seat control unit.

Lumber Support Circuit Check

AIS004VY

1. CHECK LUMBER SUPPORT SWITCH POWER SUPPLY

1. Turn ignition switch OFF.
2. Disconnect memory switch and lumber support switch connector.
3. Check voltage between "memory switch and lumber support switch" connector B316 terminal 33D (R) and ground.

33D (R) – Ground: : Battery voltage

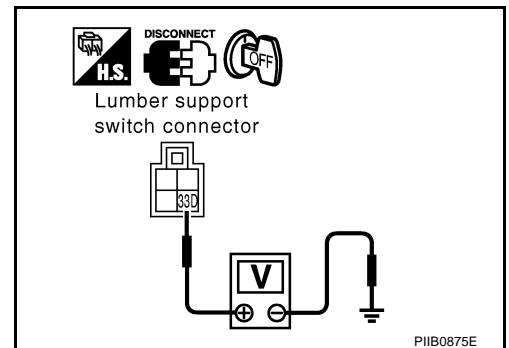

OK or NG

OK >> GO TO 2.

NG >> Repair or replace harness between fuse block (J/B) and "memory switch and lumber support switch".

AUTOMATIC DRIVE POSITIONER

2. CHECK LUMBER SUPPORT SWITCH

Check voltage between number support switch connector and ground.

Connector	Terminals (Wire color)		Condition	Voltage (V) (Approx.)
	(+)	(-)		
B314	4 (L)	Ground	Lumber support switch turned to forward	Battery voltage
			Lumber support switch neutral position	0
	5 (W)		Lumber support switch turned to backward	Battery voltage
			Lumber support switch neutral position	0

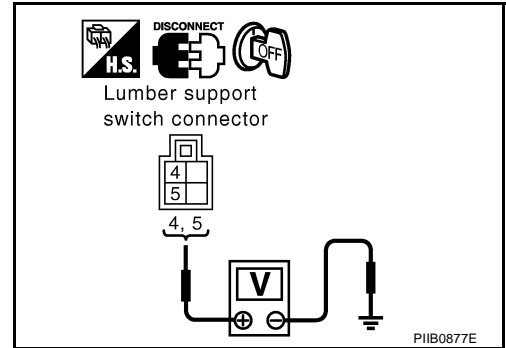

OK or NG

- OK >> GO TO 3.
- NG >> Replace power seat switch.

3. CHECK LUMBER SUPPORT MOTOR HARNESS

1. Disconnect lumber support motor connector.
2. Check continuity between "memory switch and lumber support switch" connector B314 terminal 4 (L), 5 (W) and lumber support motor connector B315 terminal 4 (L), 5 (W).

4 (L) – 4 (L) : Continuity should exist.
5 (W) – 5 (W) : Continuity should exist.

3. Check continuity between "memory switch and lumber support switch" connector B159 terminal 4 (L), 5 (W) and ground.

4 (L) – Ground : Continuity should not exist.
5 (W) – Ground : Continuity should not exist.

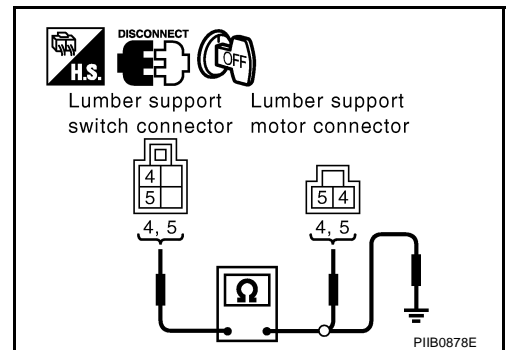

OK or NG

- OK >> GO TO 4.
- NG >> Repair or replace harness between "memory switch and lumber support switch" and lumber support motor.

4. CHECK LUMBER SUPPORT SWITCH GROUND CIRCUIT

Check continuity between lumber support switch connector B306 terminal 48D (B) and ground.

48D (B) – Ground : Continuity should exist.

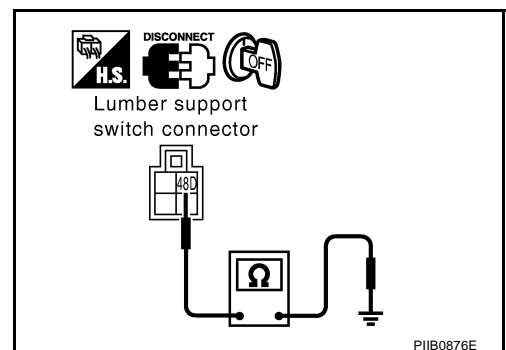

OK or NG

- OK >> Check the condition of the harness and connector.
- NG >> Repair or replace harness between "memory switch and lumber support switch" and ground.

POWER SEAT

POWER SEAT

PPF:87016

Automatic Drive Positioner Interlocking Power Seat

AIS003HO

Automatic drive positioner interlocking power seat. Refer to [SE-12, "AUTOMATIC DRIVE POSITIONER"](#) .

A
B
C
D
E
F
G
H
SE
J
K
L
M

SE

POWER SEAT

Schematic

AI5003HN

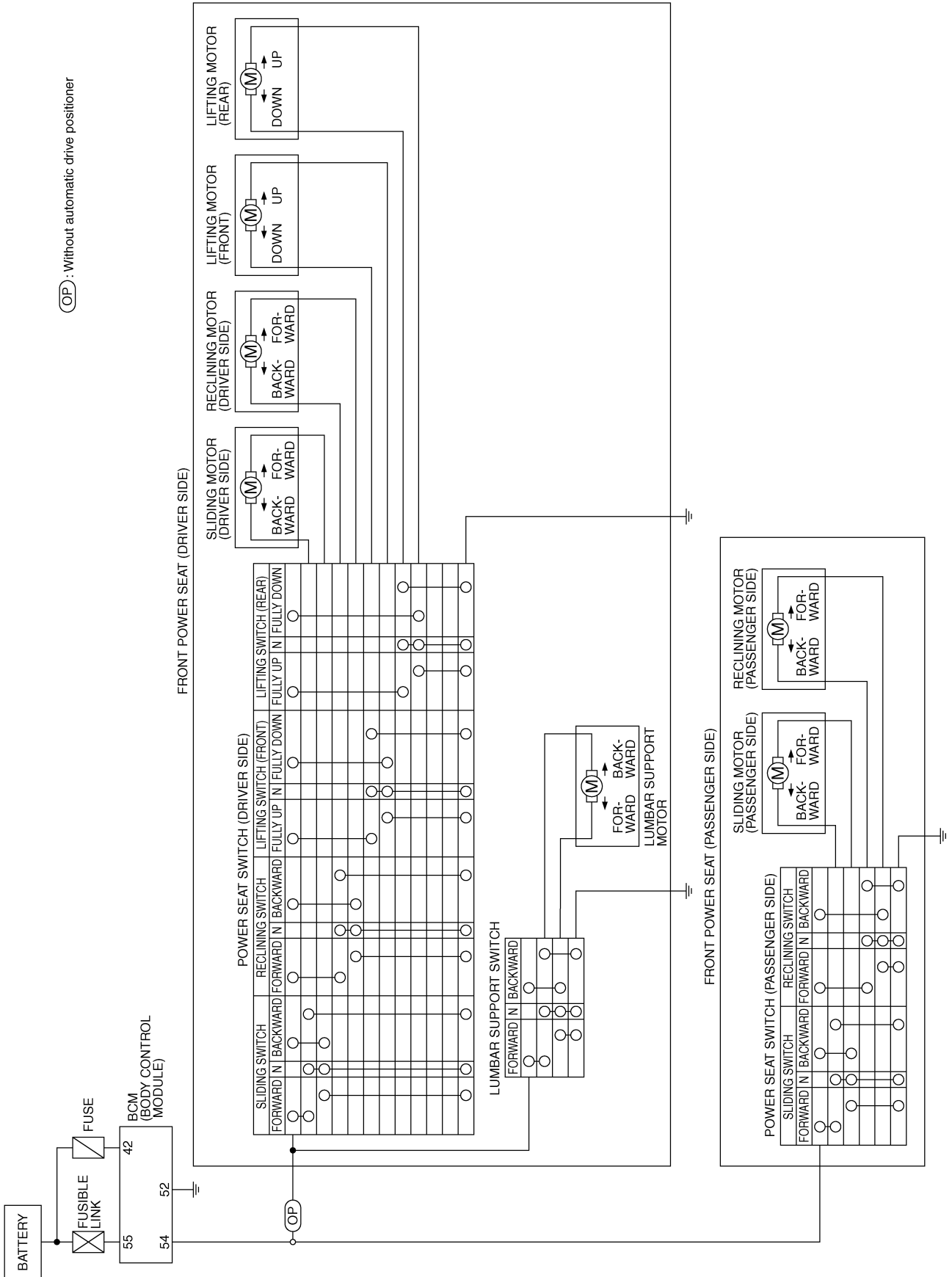

TIWB0195E

POWER SEAT

Wiring Diagram—SEAT—/Driver Side Without Automatic Drive Positioner

AIS004US

SE-SEAT-01

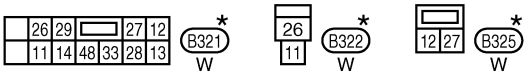
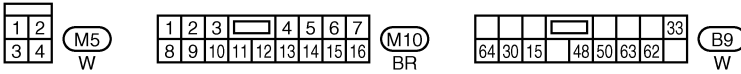
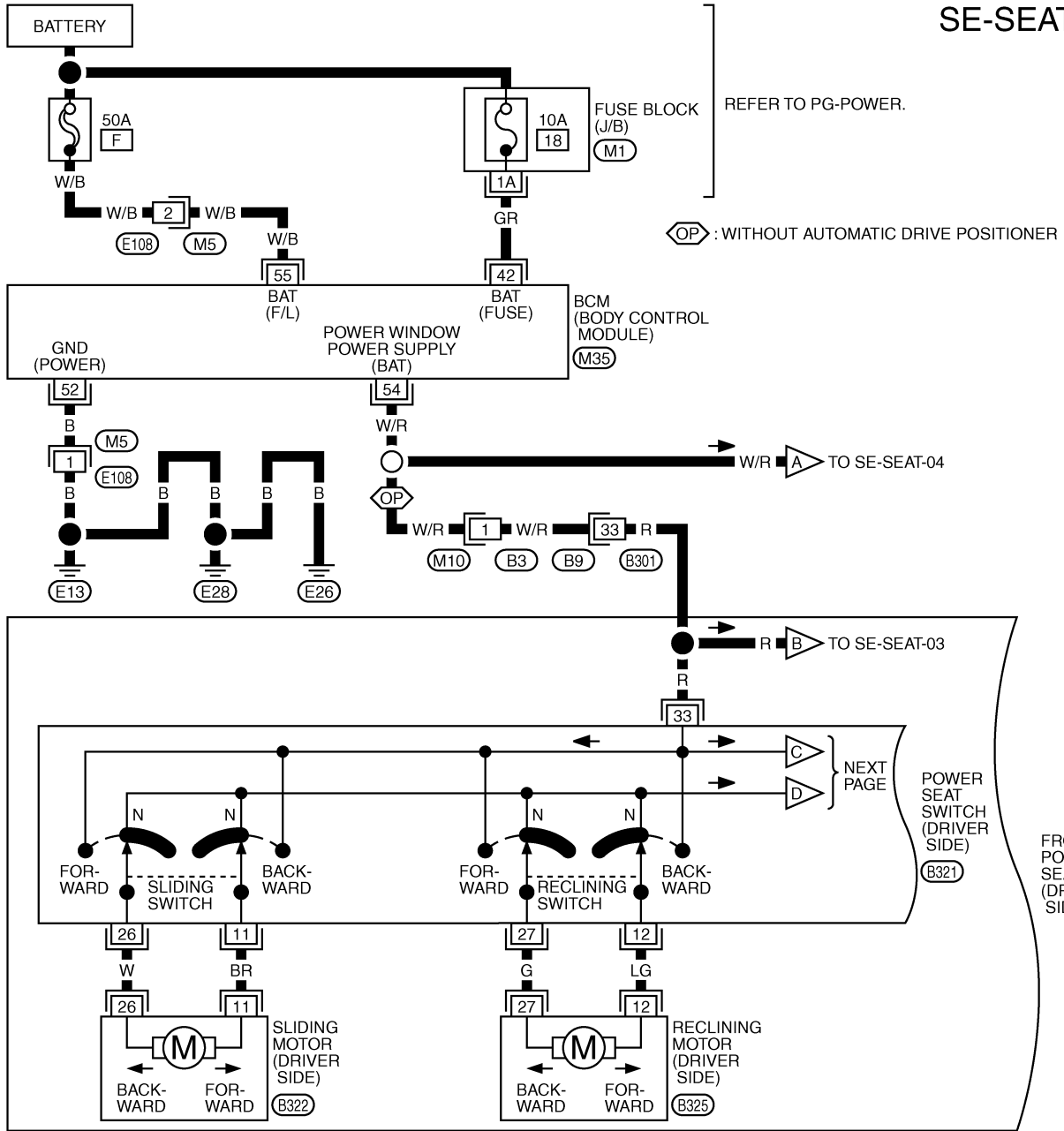

*: THIS CONNECTOR IS NOT SHOWN IN "HARNESS LAYOUT", PG SECTION.

REFER TO THE FOLLOWING.

(M1) - FUSE BLOCK-JUNCTION BOX (J/B)

(M35) - ELECTRICAL UNITS

TIWB0196E

POWER SEAT

SE-SEAT-02

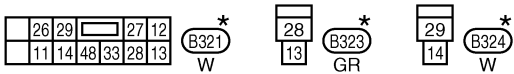
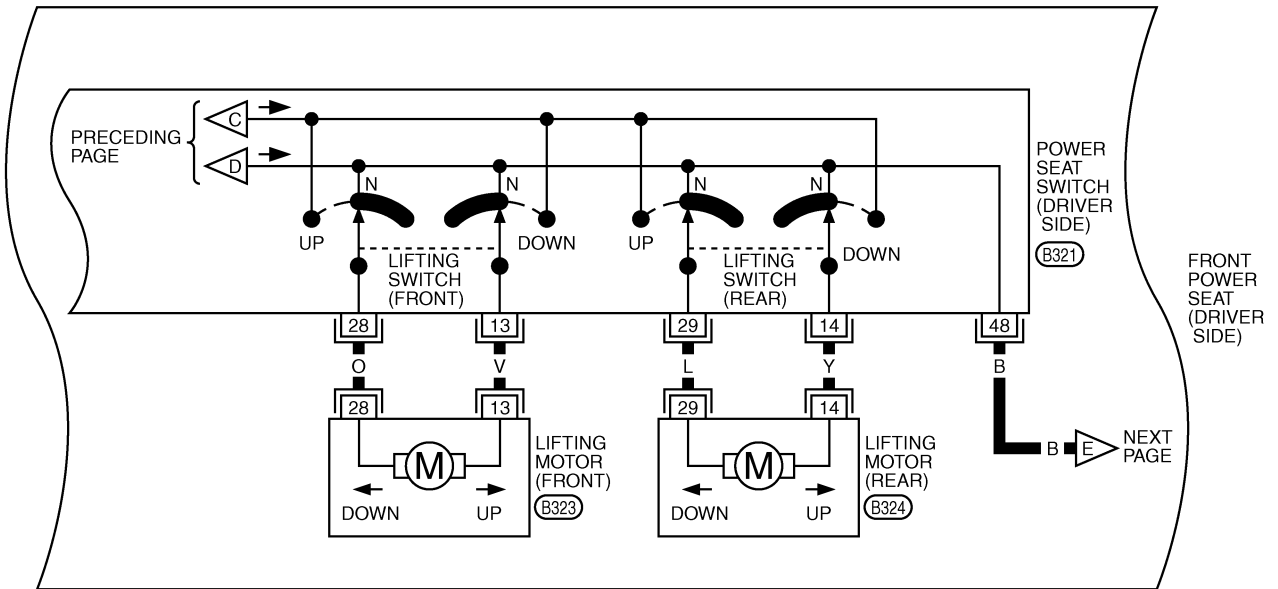

*: THIS CONNECTOR IS NOT SHOWN IN "HARNESS LAYOUT", PG SECTION.

TIWA0531E

POWER SEAT

SE-SEAT-03

A
B
C
D
E
F
G
H
SE
J
K
L
M

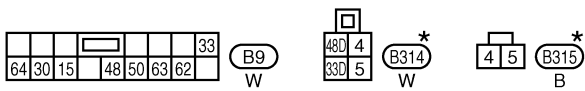
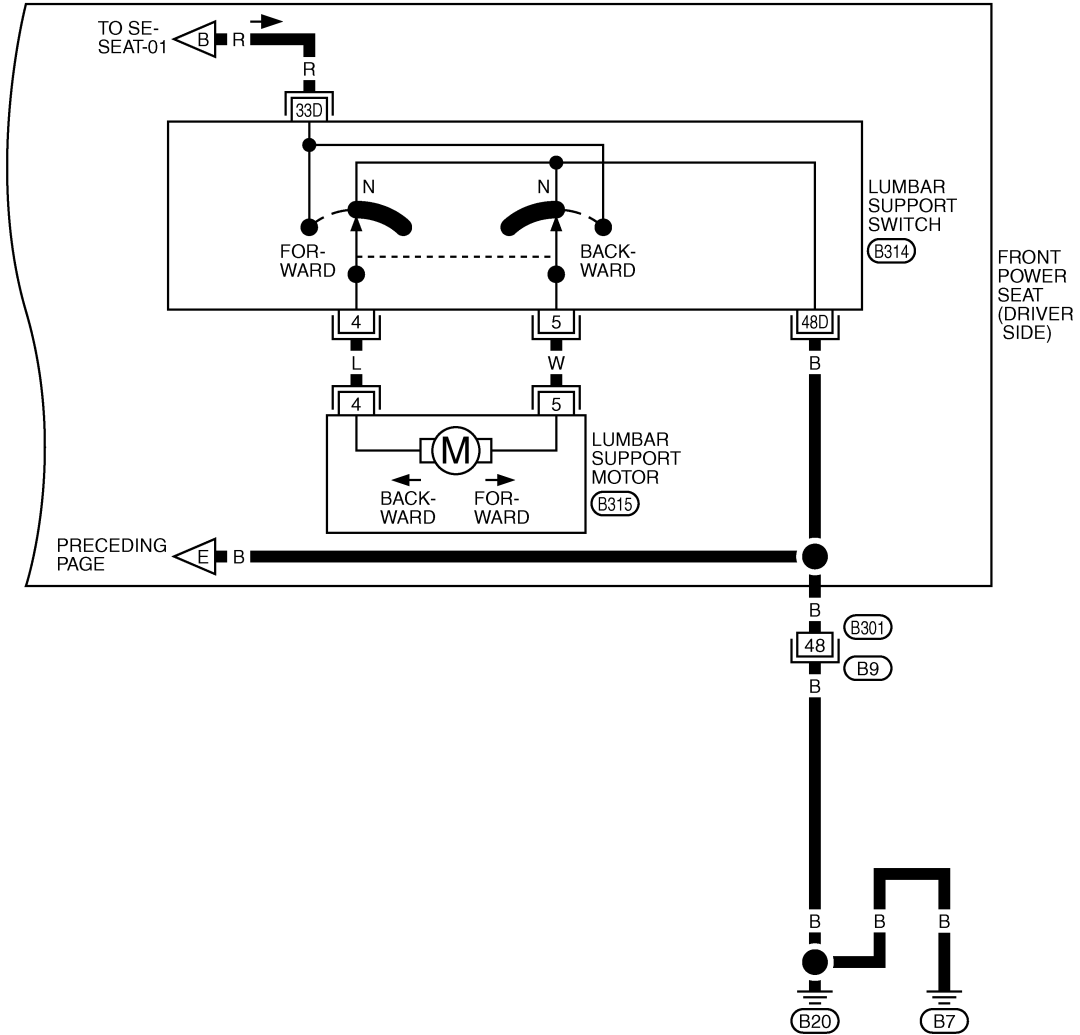

*: THIS CONNECTOR IS NOT SHOWN IN "HARNESS LAYOUT", PG SECTION.

TIWA0532E

POWER SEAT

Wiring Diagram—SEAT—/Passenger Side

AIS004UT

SE-SEAT-04

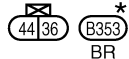
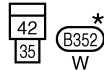
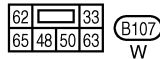
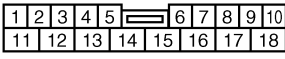
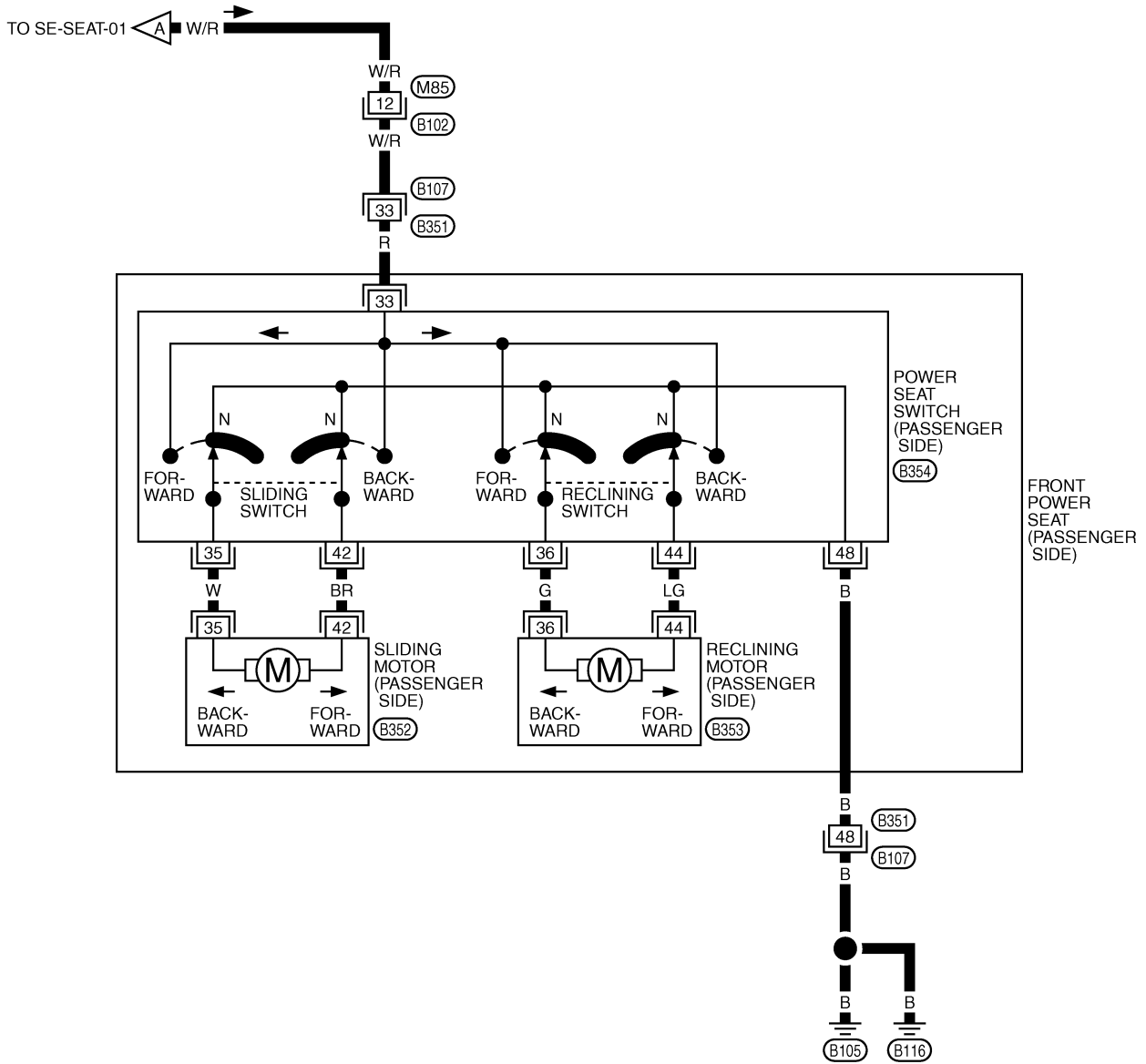

*: THIS CONNECTOR IS NOT SHOWN IN "HARNESS LAYOUT", PG SECTION.

TIWA0533E

HEATED SEAT

HEATED SEAT

PFP:87335

Description

AIS001TK

- When handling seat, be extremely careful not to scratch heating unit.
- To replace heating unit, seat trim and pad should be separated.
- Do not use any organic solvent, such as thinner, benzene, alcohol, etc. to clean trims.

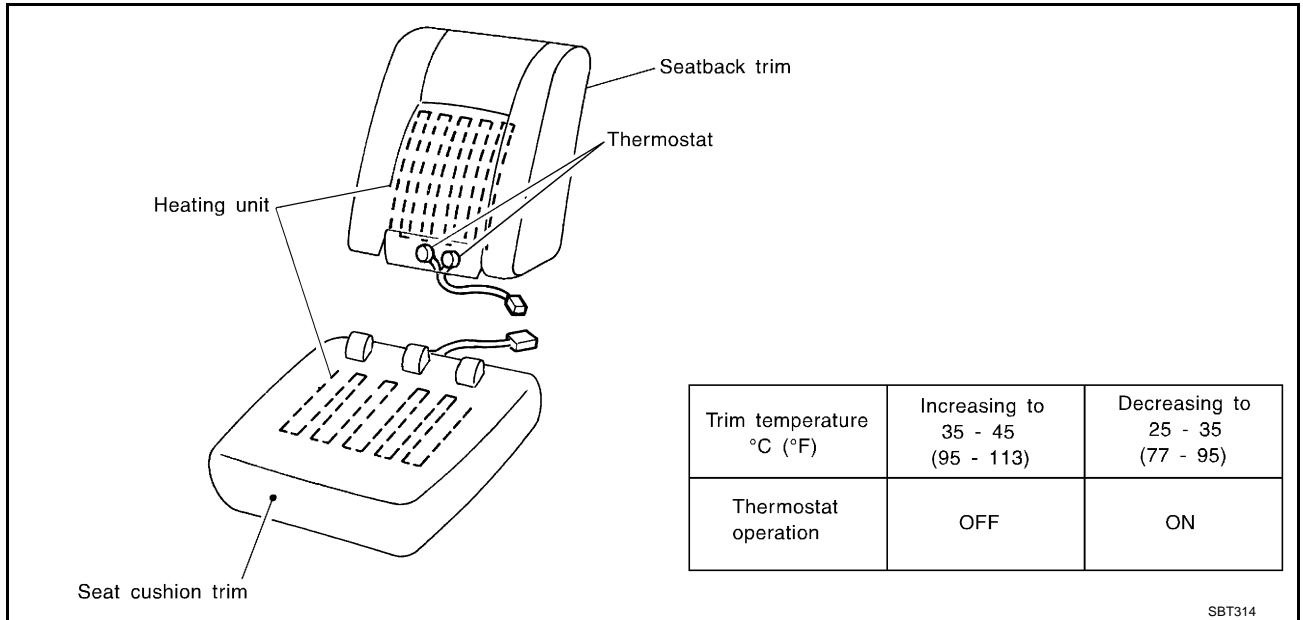

A
B
C
D
E
F
G
H
SE
J
K
L
M

HEATED SEAT

Schematic

AIS001TL

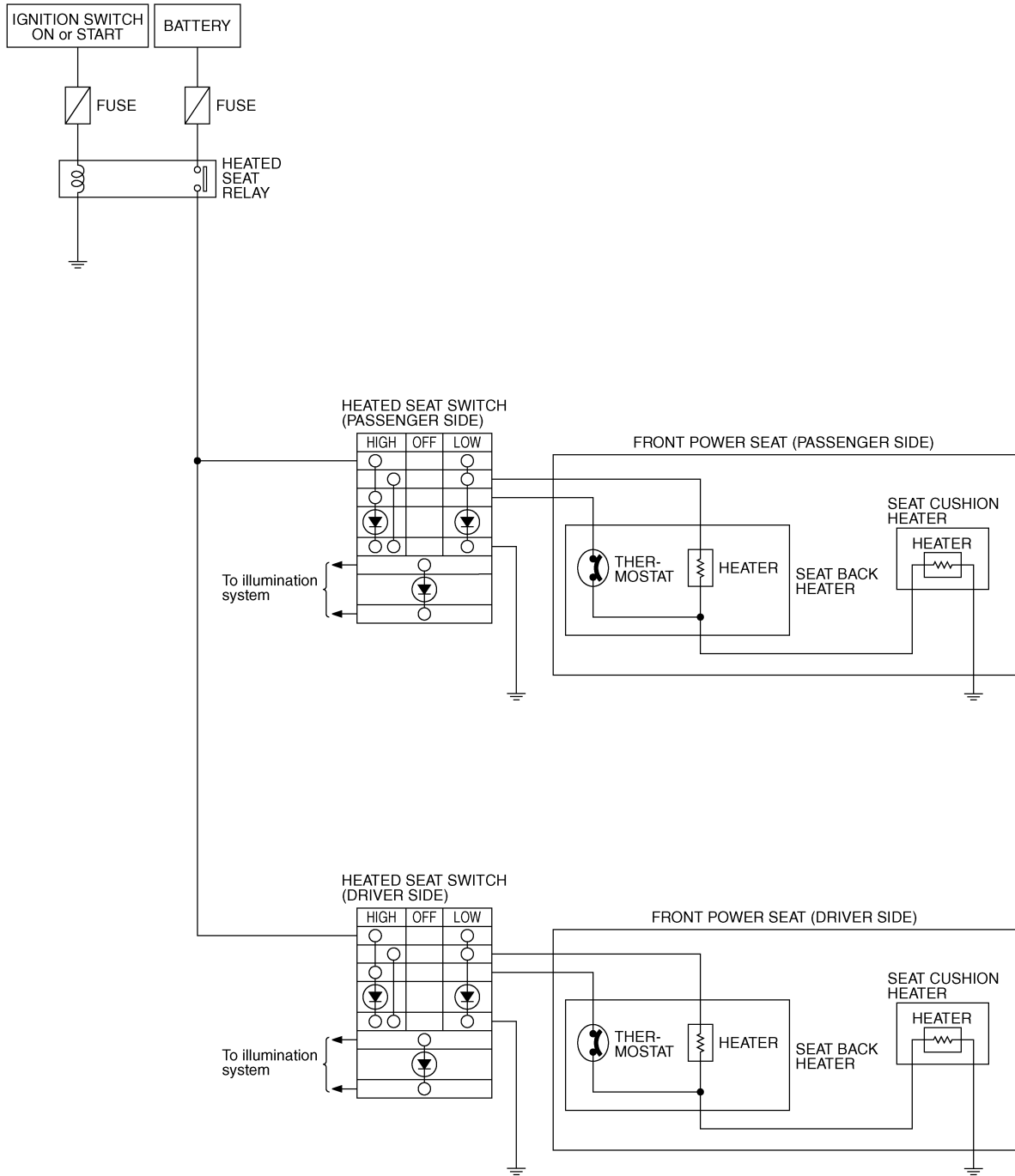

TIWB0197E

HEATED SEAT

Wiring Diagram—HSEAT—

AIS001TM

SE-HSEAT-01

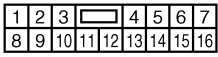
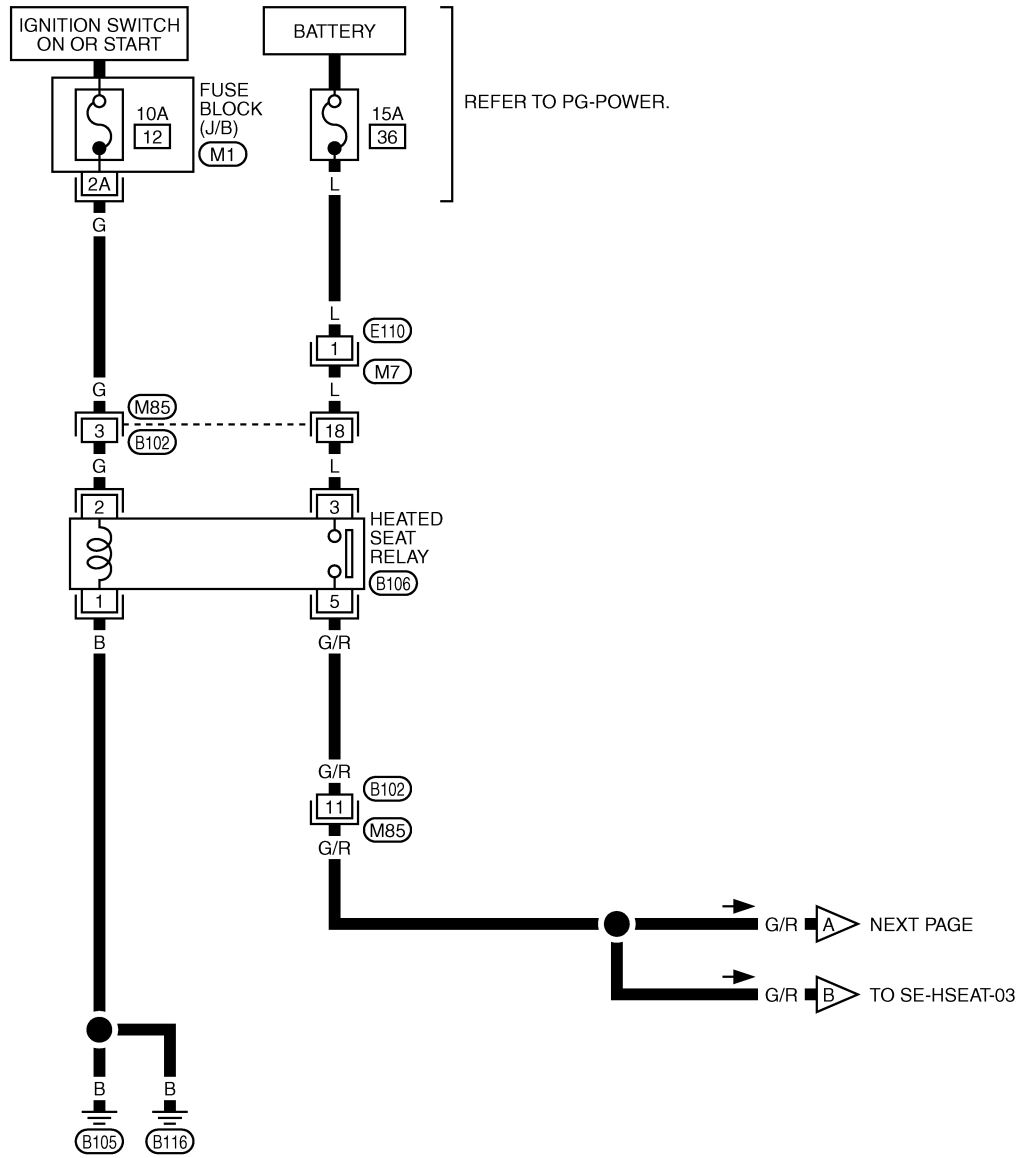

M7
GR

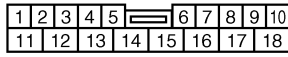

M85
W

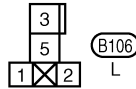

B106
L

REFER TO THE FOLLOWING.

M1 - FUSE BLOCK-JUNCTION BOX (J/B)

TIWA0320E

HEATED SEAT

SE-HSEAT-02

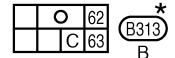
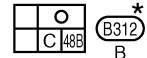
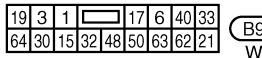
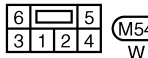
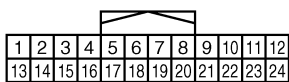
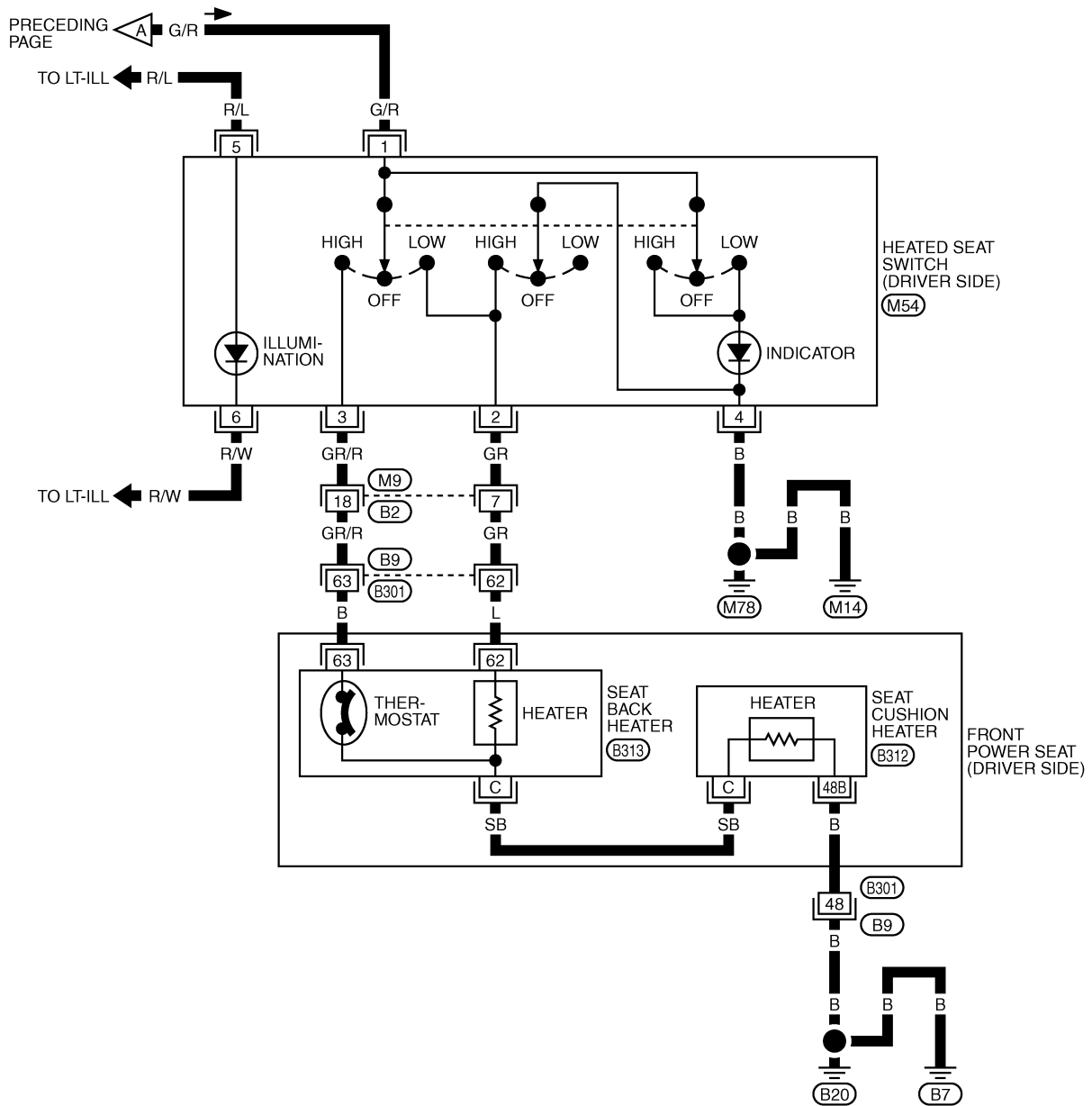

*: THIS CONNECTOR IS NOT SHOWN IN "HARNES LAYOUT", PG SECTION.

TIWB0198E

HEATED SEAT

SE-HSEAT-03

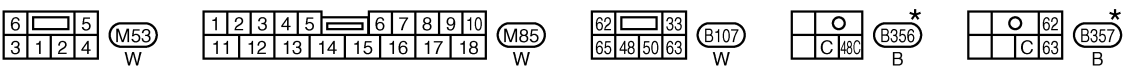
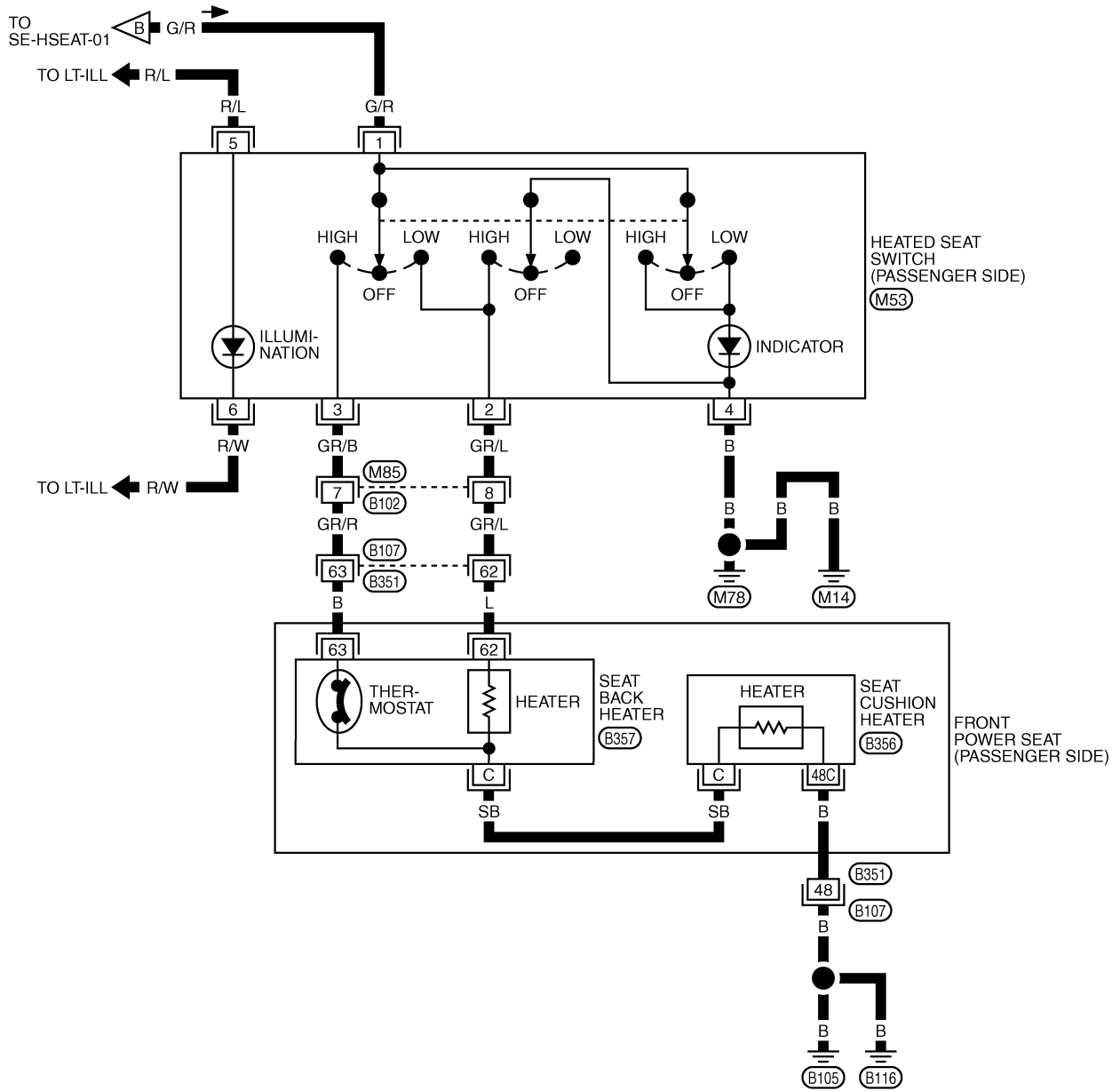

*: THIS CONNECTOR IS NOT SHOWN IN "HARNESS LAYOUT", PG SECTION.

TIWB0199E

FRONT SEAT

PFP:87000

AIS0063S

FRONT SEAT

Removal and Installation DRIVER SIDE POWER SEAT

SEC. 870

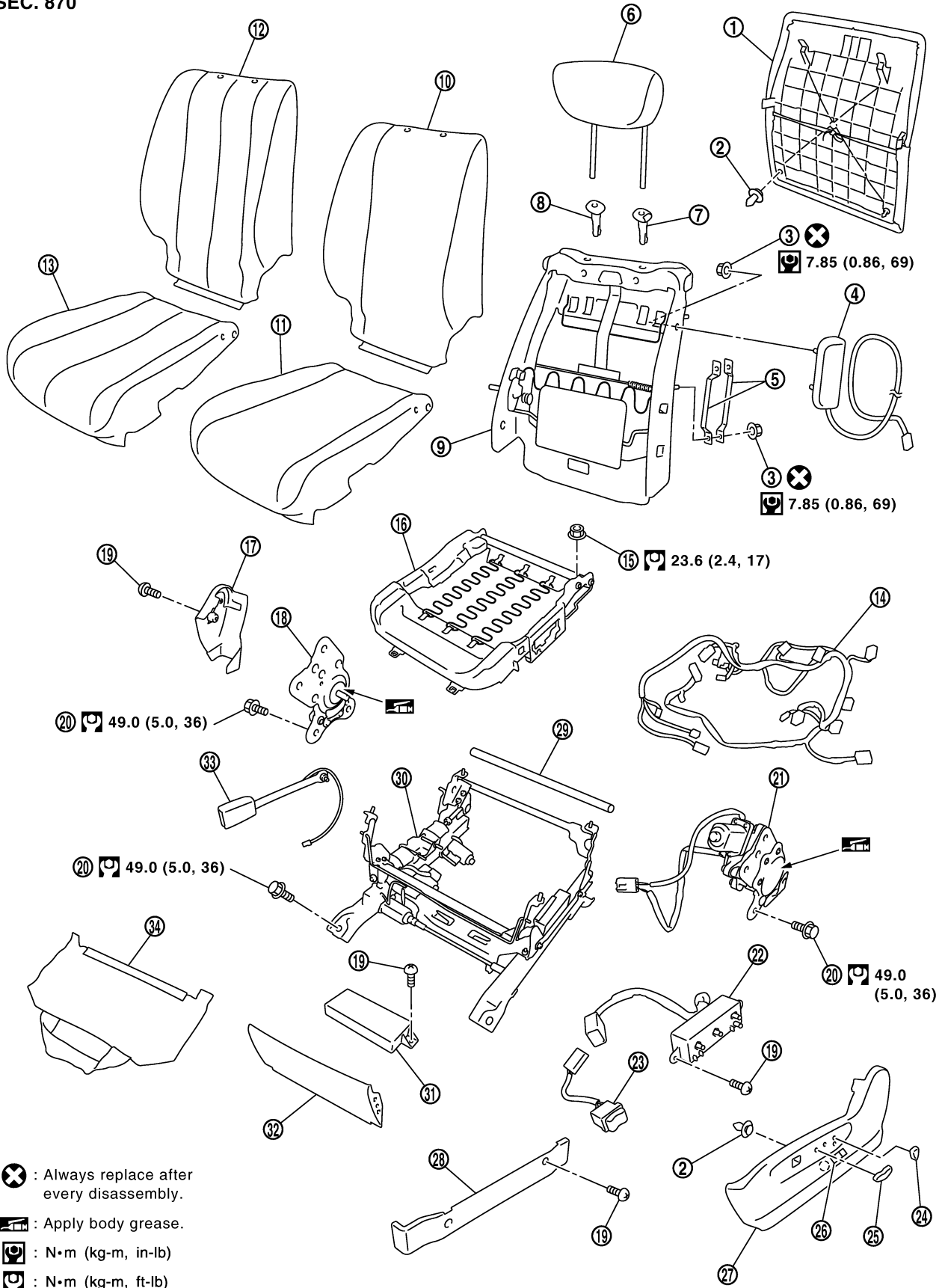

PIIB0408E

FRONT SEAT

1. Seatback board	2. Clip (C101)	3. Nut	A
4. Side air bag module	5. Inner stay	6. Headrest	
7. Headrest holder (locked)	8. Headrest holder (free)	9. Seatback frame	
10. Seatback pad	11. Seat cushion pad	12. Seatback trim	B
13. Seat cushion trim	14. Power seat harness	15. Nut	
16. Seat cushion frame	17. Seat cushion inner finisher	18. Reclining inner device	
19. Screw	20. Bolt	21. Reclining outer device	C
22. Power seat switch	23. Pedal adjusting switch	24. Reclining switch knob	
25. Slide & lifter switch knob	26. Lumbar support switch knob	27. Seat cushion outer finisher	
28. Seat cushion outer cover	29. Reclining device rod	30. Seat lifter link slide assembly	D
31. Seat control unit	32. Seat cushion front finisher	33. Seat belt buckle	
34. Seat cushion under cover			E

SE

J

K

L

M

FRONT SEAT

PASSENGER SIDE MANUAL SEAT

SEC. 870

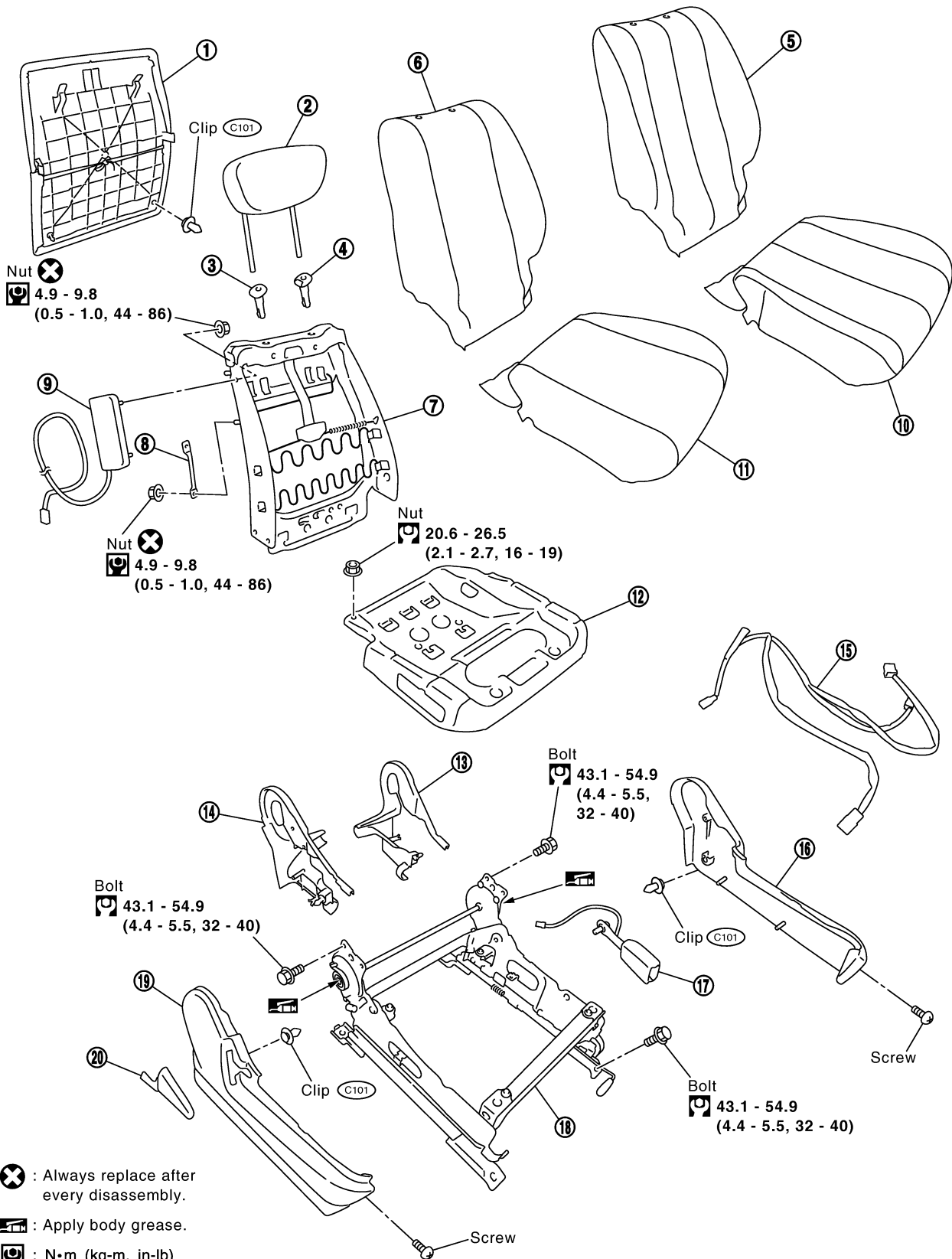

PIIA4302E

FRONT SEAT

- | | | |
|---------------------------------|------------------------------|---------------------------|
| 1. Seatback board | 2. Headrest | 3. Headrest holder (free) |
| 4. Headrest holder (locked) | 5. Seatback trim | 6. Seatback pad |
| 7. Seatback frame | 8. Inner stay | 9. Side air bag module |
| 10. Seat cushion trim | 11. Seat cushion pad | 12. Seat cushion frame |
| 13. Seat cushion inner cover | 14. Seat cushion outer cover | 15. Seat harness |
| 16. Seat cushion inner finisher | 17. Seat belt buckle | 18. Seat slide assembly |
| 19. Seat cushion outer finisher | 20. Reclining lever knob | |

REMOVAL

When removing or installing the seat trim, carefully handle it to keep dirt out and avoid damage.

CAUTION:

- Before removing the front seat, turn ignition switch OFF, disconnect both battery cables and wait and least 3 minutes.
 - When checking the power seat circuit for continuity using a circuit tester, do not confuse its connector with the side air bag module connector. Such an error may cause the air bag to deploy.
 - Do not drop, tilt, or bump the side air bag module installing in the seat. Always handle it with care.
1. Remove the front leg cover and rear leg cover (LH/RH).

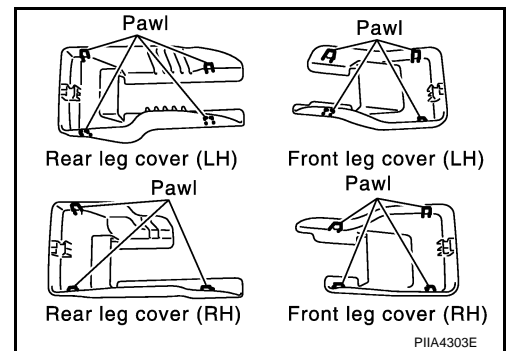

NOTE:

- Slide the seat backward, and disconnect the front tabs on the front leg cover. Then move the cover toward the rear of the vehicle, and pull up to remove.
 - Slide the seat forward, then disengage the tabs on the front LH/RH of the rear leg cover and tabs engaged into the rail. Then pull the cover toward the rear of the vehicle.
2. Slide the seat until the body mounting bolts are visible and a tool can be inserted.

NOTE:

When disassembling the driver seat after removal, set the front/rear cushion lifter to the top position.

3. Remove the body mounting bolts.
4. Disconnect both battery cables.
5. Remove the harness connector for the side air bag module.
6. Remove the power seat harness connector and vehicle harness fixing clip out of the vehicle.

NOTE:

When removing and installing, using shop clothes, protect the parts from damage where it may interfere with others.

INSTALLATION

Install in the reverse order of removal.

NOTE:

Be sure to insert the rear end tab of the rear leg cover under the rail.

FRONT SEAT

SEATBACK TRIM AND PAD

Removal

NOTE:

Be sure to set the front/rear cushion lifter to the top position.

1. Remove the seatback board from the back of the seatback.

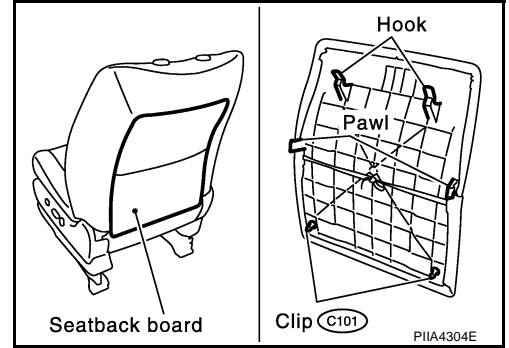

2. Remove the retainer.

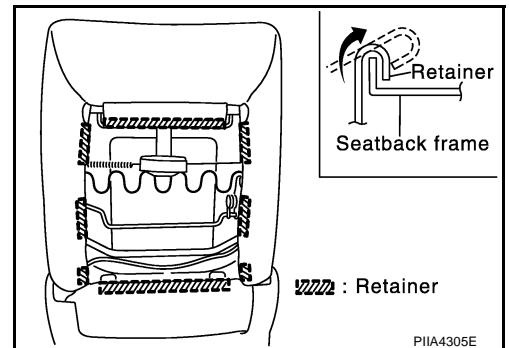

3. Squeeze and pull up headrest holder tabs to remove front seatback frame.

NOTE:

Before installing the headrest holder, check its orientation (front/rear and left/right).

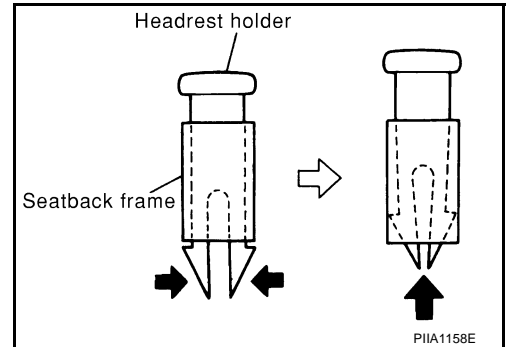

4. Remove the stay securing the inner cloth.

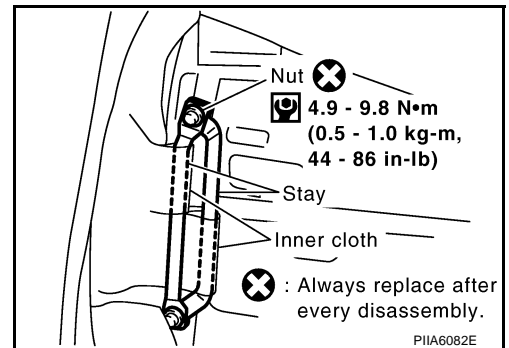

5. Remove the seat heater harness connector. After removing the seatback trim & pad, remove the hog ring to separate the trim, pad, and seatback heater unit.

Installation

Install in the reverse order of removal.

FRONT SEAT

REMOVAL OF SEATBACK ASSEMBLY

1. After completing the steps 1 and 2 of "SEATBACK TRIM AND PAD", remove the harness connectors for the reclining motor and lumbar support motor (driver seat only).
2. Pull out the harness connector for the side air bag from the seat cushion.
3. Remove the reclining device mounting bolts on the seatback frame, and remove the seatback assembly.

NOTE:

When assembling the seatback frame, make sure that the reclining device are locked on both sides, and be sure to temporarily tighten the bolts, then tighten them finally.

INSTALLATION OF SEATBACK ASSEMBLY

Install in the reverse order of removal.

SEAT CUSHION TRIM AND PAD (POWER SEAT)

Removal

1. Remove the seat cushion front finisher.
2. Remove the power seat switch knob.
3. Remove the seat cushion outer finisher.

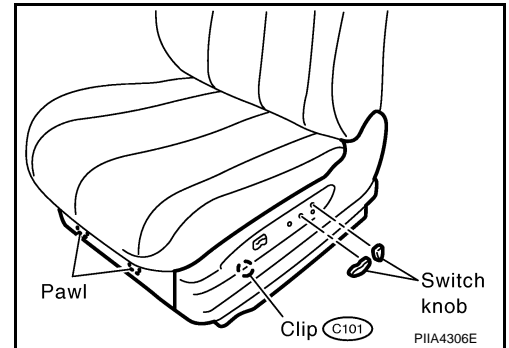

4. Remove the power seat switch assembly.
5. Partially pull off the trim at the rear of the seat cushion forward, and remove the hog rings on the seat cushion pad.

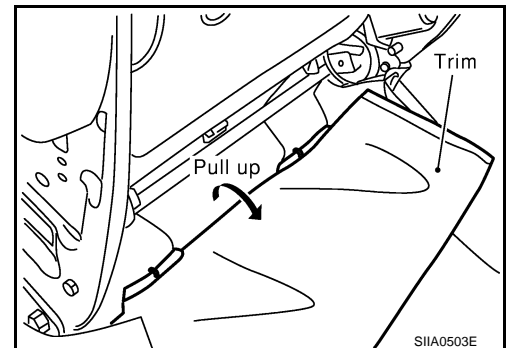

6. Remove the retainer on the seat cushion frame, then remove the harness connector for the seat heater.
7. After removing the seat cushion trim & pad, remove the hog rings to separate the trim and pad.

Installation

Install in the reverse order of removal.

SEAT CUSHION TRIM AND PAD (MANUAL SEAT)

Removal

1. Pull up tabs of reclining lever inside. Slide knob forward to remove.

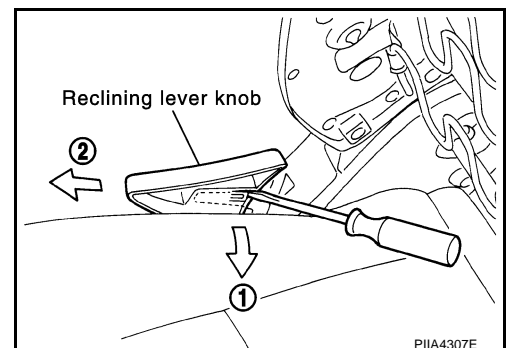

FRONT SEAT

2. Remove the seat cushion outer finisher and inner finisher.

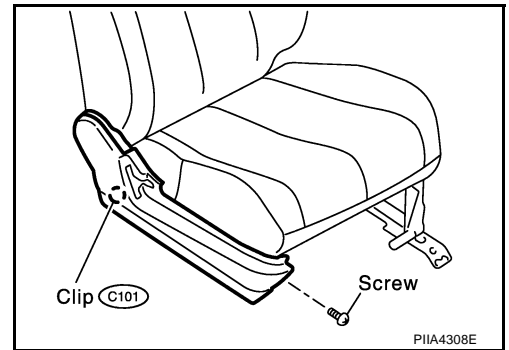

3. Remove bolts on the under side of seat cushion.
4. Remove hog ring from under seat cushion frame.
5. After removing the seat cushion trim & pad, remove the hog ring to separate the trim and pad.

Installation

Install in the reverse order of removal.

REAR SEAT

PFP:88300

A
B
C
D
E
F
G
H
SE
J
K
L
M

REAR SEAT

Removal and Installation LH SIDE SEAT

AIS002KO

SEC. 880

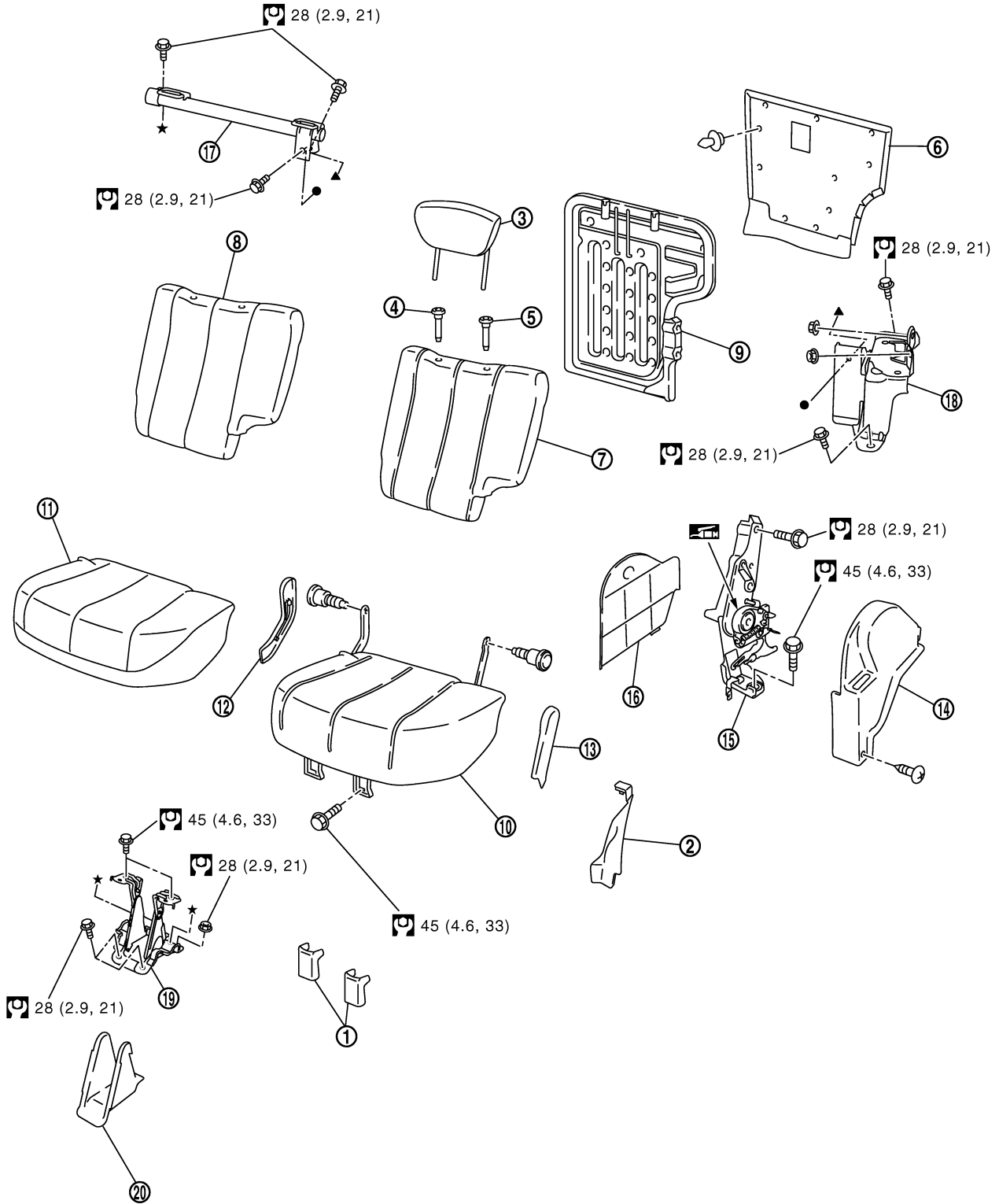

: N•m (kg-m, ft-lb)

PIIB4963E

REAR SEAT

- | | | |
|---|---|---------------------------------|
| 1. Leg cover | 2. Seat outer side cover | 3. Headrest |
| 4. Headrest holder (free) | 5. Headrest holder (locked) | 6. Seatback board |
| 7. Seatback pad | 8. Seatback trim | 9. Seatback frame |
| 10. Seat cushion pad | 11. Seat cushion trim | 12. Seat cushion inner cover |
| 13. Seat cushion outer cover | 14. Reclining device outer cover | 15. Reclining device |
| 16. Reclining device inner cover | 17. Rear seat frame (RH) | 18. Rear seat side bracket (LH) |
| 19. Rear seat center bracket (LH seat
RH seat sharing) | 20. Rear seat center bracket cover (LH
seat RH seat sharing) | |

REAR SEAT

RH SIDE SEAT

SEC. 880

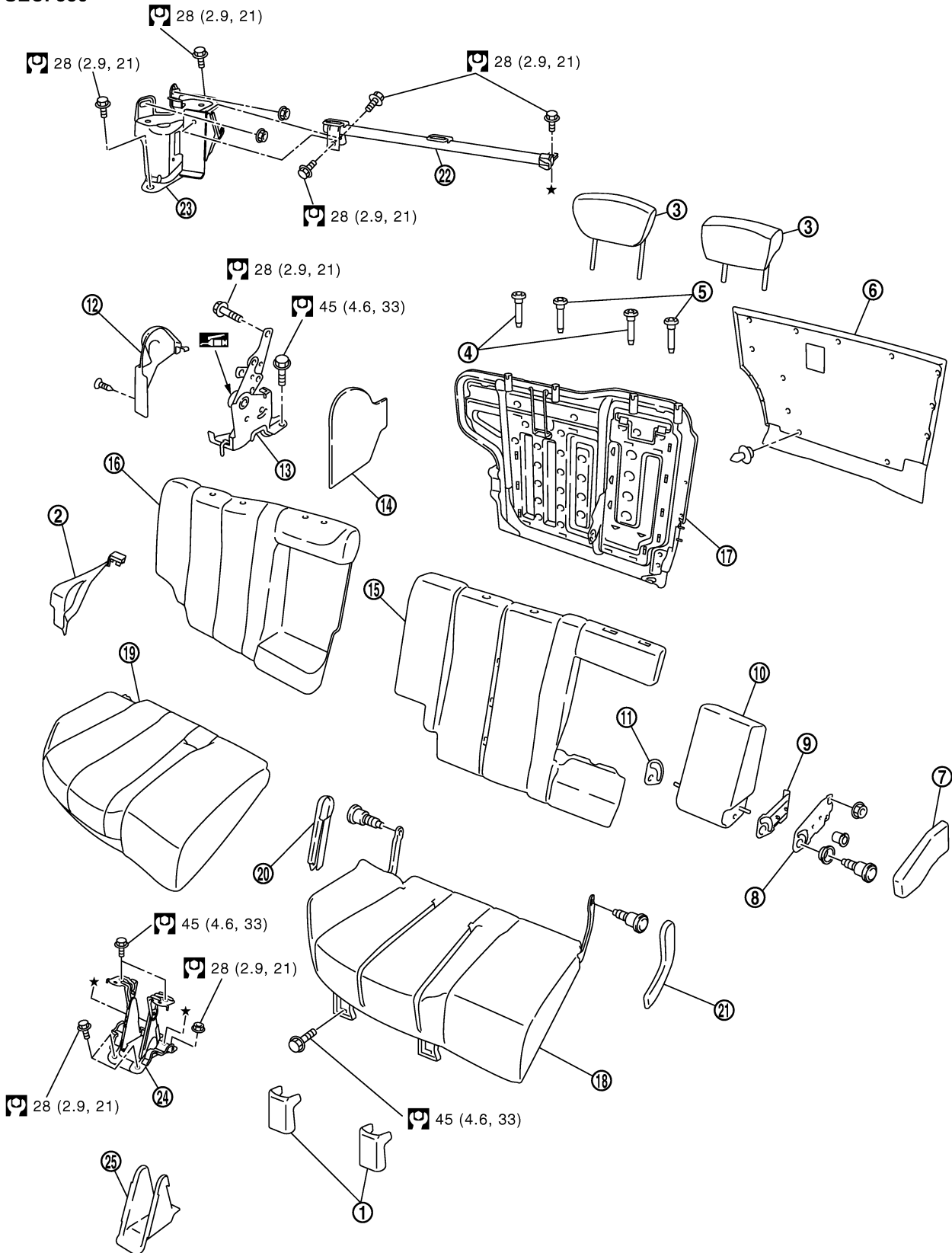

: N•m (kg-m, ft-lb)

A
B
C
D
E
F
G
H
SE
J
K
L
M

REAR SEAT

1. Leg cover
2. Seat outer side cover
3. Headrest
4. Headrest holder (free)
5. Headrest holder (locked)
6. Seatback board
7. Armrest outer cover
8. Armrest outer bracket
9. Armrest inner cover
10. Armrest trim and pad
11. Armrest inner bracket
12. Reclining device outer cover
13. Reclining device
14. Reclining device inner cover
15. Seat back pad
16. Seat back trim
17. Seat back frame
18. Seat cushion pad
19. Seat cushion trim
20. Seat cushion outer cover
21. Seat cushion inner cover
22. Rear seat frame (RH)
23. Rear seat bracket (RH)
24. Seat cushion center bracket (LH seat RH seat sharing)
25. Seat cushion center bracket cover (LH seat RH seat sharing)

REMOVAL

1. Remove the leg cover.
2. Remove the seat mounting bolts.

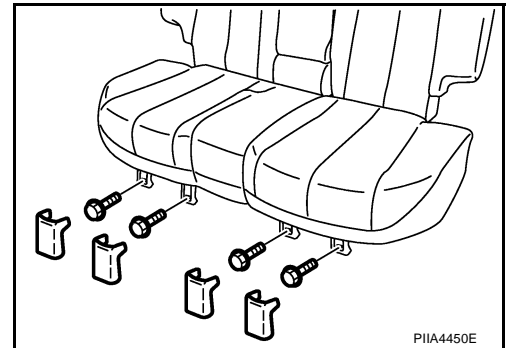

3. Fold the seatback forward.
4. Remove the seat outer side cover.
5. Remove the seat mounting bolts.
6. Remove the remote control wire.

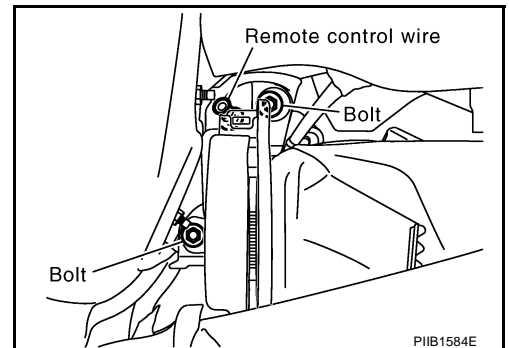

7. Remove the seat mounting bolts.

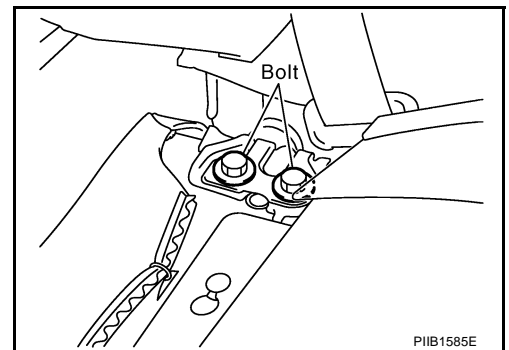

8. Remove the rear seat on the vehicle.
9. Remove the bolts, and then remove the rear seat frame (RH/LH).

INSTALLATION

Install in the reverse order of removal.

REAR SEAT

REMOVAL OF REMOTE CONTROL LEVER

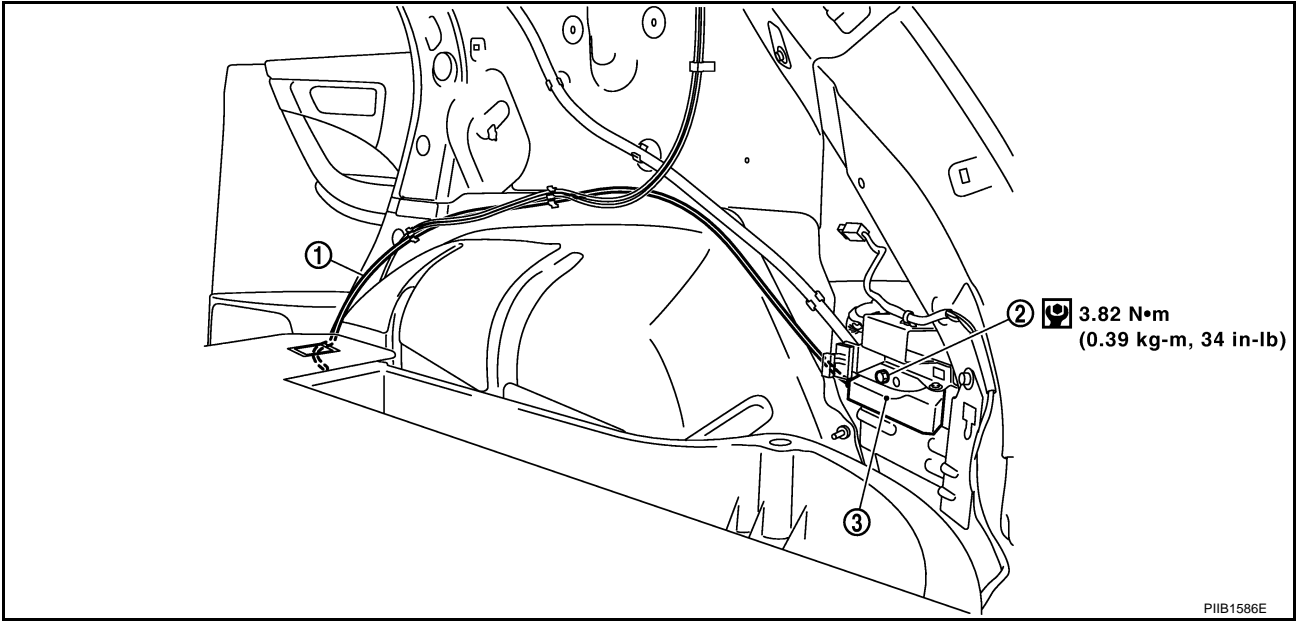

1. Remote control wire 2. Bolt 3. Remote control lever

1. Remove the rear seat. Refer to [SE-114, "REMOVAL"](#) .
2. Remove the luggage side finisher lower. Refer to [EI-38, "Removal and Installation"](#) .
3. Remove the remote control lever mounting bolt.
4. Remove the remote control lever assembly.

INSTALLATION OF REMOTE CONTROL LEVER

Install in the reverse order of removal.

A
B
C
D
E
F
G
H
SE
J
K
L
M

REAR SEAT
