

SECTION **RF**  
ROOF

A  
B  
C  
D  
E  
F  
G  
H  
J  
K  
L  
M

CONTENTS

<b>PRECAUTIONS</b> .....	<b>2</b>	Terminals and Reference Value for Sunroof Motor Assembly .....	16
Precautions for Supplemental Restraint System (SRS) "AIR BAG" and "SEAT BELT PRE-TENSIONER" .....	2	Work Flow .....	17
Precautions .....	2	CONSULT-II Function (BCM) .....	18
<b>PREPARATION</b> .....	<b>3</b>	"RETAINED PWR" .....	18
Special Service Tools .....	3	Data Monitor .....	19
Commercial Service Tools .....	3	Active Test .....	19
<b>SQUEAK AND RATTLE TROUBLE DIAGNOSES</b> .....	<b>4</b>	Work Support .....	19
Work Flow .....	4	Trouble Diagnosis Chart by Symptom .....	20
CUSTOMER INTERVIEW .....	4	BCM Power Supply and Ground Circuit Check .....	20
DUPLICATE THE NOISE AND TEST DRIVE .....	5	Sunroof Motor Assembly Power Supply and Ground Circuit Check .....	22
CHECK RELATED SERVICE BULLETINS .....	5	BCM Check .....	23
LOCATE THE NOISE AND IDENTIFY THE ROOT CAUSE .....	5	Sunroof Switch Circuit Check 1 .....	24
REPAIR THE CAUSE .....	5	Sunroof Switch Circuit Check 2 .....	25
CONFIRM THE REPAIR .....	6	Sunroof Switch Circuit Check 3 .....	25
Generic Squeak and Rattle Troubleshooting .....	6	Sunroof Switch Circuit Check 4 .....	26
INSTRUMENT PANEL .....	6	Sunroof Switch Circuit Check 5 .....	27
CENTER CONSOLE .....	6	Sunroof Switch Circuit Check 6 .....	27
DOORS .....	6	Sunroof Switch Circuit Check 7 .....	28
TRUNK .....	7	Sunroof Switch Circuit Check 8 .....	29
SUNROOF/HEADLINING .....	7	Sunroof Switch Circuit Check 9 .....	29
SEATS .....	7	Sunroof Switch Circuit Check 10 .....	31
UNDERHOOD .....	7	Sunroof Switch Circuit Check 11 .....	32
Diagnostic Worksheet .....	8	Sunroof Switch Circuit Check 12 .....	33
<b>SUNROOF</b> .....	<b>10</b>	Door Switch Check (With Intelligent Key) .....	34
Component Parts and Harness Connector Location .....	10	Door Switch Check (Without Intelligent Key) .....	36
System Description .....	10	Wind Deflector Inspection .....	39
SUNROOF OPERATION .....	11	Link and Wire Assembly .....	39
SUNROOF SWITCH READING FUNCTION .....	11	Fitting Adjustment .....	39
RETAINED POWER OPERATION .....	11	LID WEATHERSTRIP OVERLAP ADJUSTMENT AND SURFACE MISMATCH ADJUSTMENT .....	40
ANTI-PINCH FUNCTION .....	12	Removal and Installation .....	40
MEMORY RESET PROCEDURE .....	12	SUNROOF UNIT ASSEMBLY .....	42
INITIALIZATION PROCEDURE .....	12	GLASS LID .....	43
CAN Communication System Description .....	13	SUNSHADE .....	44
CAN Communication Unit .....	13	WIND DEFLECTOR .....	44
Wiring Diagram — SROOF — .....	14	SUNROOF MOTOR ASSEMBLY .....	44
Terminals and Reference Value for BCM .....	16		

RF

# PRECAUTIONS

## PRECAUTIONS

PFP:00001

### Precautions for Supplemental Restraint System (SRS) “AIR BAG” and “SEAT BELT PRE-TENSIONER”

AIS002DV

The Supplemental Restraint System such as “AIR BAG” and “SEAT BELT PRE-TENSIONER”, used along with a front seat belt, helps to reduce the risk or severity of injury to the driver and front passenger for certain types of collision. This system includes seat belt switch inputs and dual stage front air bag modules. The SRS system uses the seat belt switches to determine the front air bag deployment, and may only deploy one front air bag, depending on the severity of a collision and whether the front occupants are belted or unbelted. Information necessary to service the system safely is included in the SRS and SB section of this Service Manual.

#### **WARNING:**

- To avoid rendering the SRS inoperative, which could increase the risk of personal injury or death in the event of a collision which would result in air bag inflation, all maintenance must be performed by an authorized NISSAN/INFINITI dealer.
- Improper maintenance, including incorrect removal and installation of the SRS, can lead to personal injury caused by unintentional activation of the system. For removal of Spiral Cable and Air Bag Module, see the SRS section.
- Do not use electrical test equipment on any circuit related to the SRS unless instructed to in this Service Manual. SRS wiring harnesses can be identified by yellow and/or orange harnesses or harness connectors.

## Precautions

AIS002DW

- Disconnect both battery cables in advance.
- Do not tamper with or force air bag lid open, as this may adversely affect air bag performance.
- Be careful not to scratch pad and other parts.
- When removing or disassembling any part, be careful not to damage or deform it. Protect parts, which may get in the way with cloth.
- When removing parts with a screwdriver or other tool, protect parts by wrapping them with vinyl or tape.
- Keep removed parts protected with cloth.
- If a clip is deformed or damaged, replace it.
- If an un reusable part is removed, replace it with a new one.
- Tighten bolts and nuts firmly to the specified torque.
- After re-assembly has been completed, make sure each part functions correctly.
- Remove stains in the following way.

#### Water-soluble stains:

Dip a soft cloth in warm water, and then squeeze it tightly. After wiping the stain, wipe with a soft dry cloth.

#### Oil stain:

Dissolve a synthetic detergent in warm water (density of 2 to 3% or less), dip the cloth, then clean off the stain with the cloth. Next, dip the cloth in fresh water and squeeze it tightly. Then clean off the detergent completely. Then wipe the area with a soft dry cloth.

- Do not use any organic solvent, such as thinner or benzene.

# PREPARATION

## PREPARATION

PFP:00002

### Special Service Tools

AIS002DX

The actual shapes of Kent-Moore tools may differ from those of special service tools illustrated here.

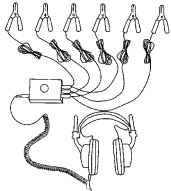
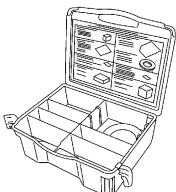
Tool number (Kent-Moore No.) Tool name	Description
(J-39570) Chassis ear  	Locating the noise
(J-43980) NISSAN Squeak and Rattle Kit  	Repairing the cause of noise

### Commercial Service Tools

AIS002DY

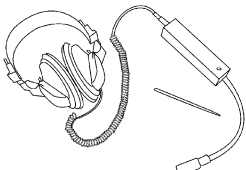
Tool name	Description
Engine ear  	Locating the noise

A  
B  
C  
D  
E  
F  
G  
H  
RF  
J  
K  
L  
M

RF

# SQUEAK AND RATTLE TROUBLE DIAGNOSES

## SQUEAK AND RATTLE TROUBLE DIAGNOSES

PFP:00000

### Work Flow

AIS0038P



### CUSTOMER INTERVIEW

Interview the customer if possible, to determine the conditions that exist when the noise occurs. Use the Diagnostic Worksheet during the interview to document the facts and conditions when the noise occurs and any customer's comments; refer to [RF-8, "Diagnostic Worksheet"](#). This information is necessary to duplicate the conditions that exist when the noise occurs.

- The customer may not be able to provide a detailed description or the location of the noise. Attempt to obtain all the facts and conditions that exist when the noise occurs (or does not occur).
- If there is more than one noise in the vehicle, be sure to diagnose and repair the noise that the customer is concerned about. This can be accomplished by test driving the vehicle with the customer.
- After identifying the type of noise, isolate the noise in terms of its characteristics. The noise characteristics are provided so the customer, service adviser and technician are all speaking the same language when defining the noise.
- Squeak —(Like tennis shoes on a clean floor)  
Squeak characteristics include the light contact/fast movement/brought on by road conditions/hard surfaces=higher pitch noise/softer surfaces=lower pitch noises/edge to surface=chirping
- Creak—(Like walking on an old wooden floor)  
Creak characteristics include firm contact/slow movement/twisting with a rotational movement/pitch dependent on materials/often brought on by activity.
- Rattle—(Like shaking a baby rattle)  
Rattle characteristics include the fast repeated contact/vibration or similar movement/loose parts/missing clip or fastener/incorrect clearance.
- Knock —(Like a knock on a door)  
Knock characteristics include hollow sounding/sometimes repeating/often brought on by driver action.
- Tick—(Like a clock second hand)  
Tick characteristics include gentle contacting of light materials/loose components/can be caused by driver action or road conditions.
- Thump—(Heavy, muffled knock noise)  
Thump characteristics include softer knock/dead sound often brought on by activity.
- Buzz—(Like a bumble bee)  
Buzz characteristics include high frequency rattle/firm contact.
- Often the degree of acceptable noise level will vary depending upon the person. A noise that you may judge as acceptable may be very irritating to the customer.
- Weather conditions, especially humidity and temperature, may have a great effect on noise level.

# SQUEAK AND RATTLE TROUBLE DIAGNOSES

## DUPLICATE THE NOISE AND TEST DRIVE

If possible, drive the vehicle with the customer until the noise is duplicated. Note any additional information on the Diagnostic Worksheet regarding the conditions or location of the noise. This information can be used to duplicate the same conditions when you confirm the repair.

If the noise can be duplicated easily during the test drive, to help identify the source of the noise, try to duplicate the noise with the vehicle stopped by doing one or all of the following:

- 1) Close a door.
  - 2) Tap or push/pull around the area where the noise appears to be coming from.
  - 3) Rev the engine.
  - 4) Use a floor jack to recreate vehicle "twist".
  - 5) At idle, apply engine load (electrical load, half-clutch on M/T model, drive position on A/T model).
  - 6) Raise the vehicle on a hoist and hit a tire with a rubber hammer.
- Drive the vehicle and attempt to duplicate the conditions the customer states exist when the noise occurs.
  - If it is difficult to duplicate the noise, drive the vehicle slowly on an undulating or rough road to stress the vehicle body.

## CHECK RELATED SERVICE BULLETINS

After verifying the customer concern or symptom, check ASIST for Technical Service Bulletins (TSBs) related to that concern or symptom.

If a TSB relates to the symptom, follow the procedure to repair the noise.

## LOCATE THE NOISE AND IDENTIFY THE ROOT CAUSE

1. Narrow down the noise to a general area. To help pinpoint the source of the noise, use a listening tool (Chassis Ear: J-39570, Engine Ear and mechanics stethoscope).
2. Narrow down the noise to a more specific area and identify the cause of the noise by:
  - removing the components in the area that you suspect the noise is coming from.  
Do not use too much force when removing clips and fasteners, otherwise clips and fastener can be broken or lost during the repair, resulting in the creation of new noise.
  - tapping or pushing/pulling the component that you suspect is causing the noise.  
Do not tap or push/pull the component with excessive force, otherwise the noise will be eliminated only temporarily.
  - feeling for a vibration with your hand by touching the component(s) that you suspect is (are) causing the noise.
  - placing a piece of paper between components that you suspect are causing the noise.
  - looking for loose components and contact marks.  
Refer to [RF-6, "Generic Squeak and Rattle Troubleshooting"](#).

## REPAIR THE CAUSE

- If the cause is a loose component, tighten the component securely.
- If the cause is insufficient clearance between components:
  - separate components by repositioning or loosening and retightening the component, if possible.
  - insulate components with a suitable insulator such as urethane pads, foam blocks, felt cloth tape or urethane tape. A Nissan Squeak and Rattle Kit (J-43980) is available through your authorized Nissan Parts Department.

### CAUTION:

**Do not use excessive force as many components are constructed of plastic and may be damaged.**

**Always check with the Parts Department for the latest parts information.**

**The following materials are contained in the Nissan Squeak and Rattle Kit (J-43980). Each item can be ordered separately as needed.**

**URETHANE PADS [1.5 mm (0.059 in) thick]**

**Insulates connectors, harness, etc.**

**76268-9E005: 100 × 135 mm (3.94 × 5.31 in)/76884-71L01: 60×85 mm (2.36 × 3.35 in)/76884-71L02: 15 × 25 mm (0.59 × 0.98 in)**

**INSULATOR (Foam blocks)**

**Insulates components from contact.Can be used to fill space behind a panel.**

**73982-9E000: 45 mm (1.77 in) thick, 50 × 50 mm (1.97 × 1.97 in)/73982-50Y00: 10 mm (0.39 in) thick, 50 × 50 mm (1.97 × 1.97 in)**

# SQUEAK AND RATTLE TROUBLE DIAGNOSES

---

## **INSULATOR (Light foam block)**

80845-71L00: 30 mm (1.18 in) thick, 30 × 50 mm (1.18 × 1.97 in)

## **FELT CLOTH TAPE**

Used to insulate where movement does not occur. Ideal for instrument panel applications.

68370-4B000: 15 × 25 mm (0.59 × 0.98 in) pad/68239-13E00: 5 mm (0.20 in) wide tape roll

The following materials, not found in the kit, can also be used to repair squeaks and rattles.

## **UHMW(TEFLON) TAPE**

Insulates where slight movement is present. Ideal for instrument panel applications.

## **SILICONE GREASE**

Used in place of UHMW tape that will be visible or not fit.

Note: Will only last a few months.

## **SILICONE SPRAY**

Use when grease cannot be applied.

## **DUCT TAPE**

Use to eliminate movement.

## **CONFIRM THE REPAIR**

Confirm that the cause of a noise is repaired by test driving the vehicle. Operate the vehicle under the same conditions as when the noise originally occurred. Refer to the notes on the Diagnostic Worksheet.

## **Generic Squeak and Rattle Troubleshooting**

AIS0038Q

Refer to Table of Contents for specific component removal and installation information.

## **INSTRUMENT PANEL**

Most incidents are caused by contact and movement between:

1. Cluster lid A and instrument panel.
2. Acrylic lens and combination meter housing.
3. Instrument panel to front pillar garnish.
4. Instrument panel to windshield.
5. Instrument panel mounting pins.
6. Wiring harnesses behind the combination meter.
7. A/C defroster duct and duct joint.

These incidents can usually be located by tapping or moving the components to duplicate the noise or by pressing on the components while driving to stop the noise. Most of these incidents can be repaired by applying felt cloth tape or silicon spray (in hard to reach areas). Urethane pads can be used to insulate wiring harness.

### **CAUTION:**

**Do not use silicone spray to isolate a squeak or rattle. If you saturate the area with silicone, you will not be able to recheck the repair.**

## **CENTER CONSOLE**

Components to pay attention to include:

1. Shifter assembly cover to finisher.
2. A/C control unit and cluster lid C.
3. Wiring harnesses behind audio and A/C control unit.

The instrument panel repair and isolation procedures also apply to the center console.

## **DOORS**

Pay attention to the:

1. Finisher and inner panel making a slapping noise.
2. Inside handle escutcheon to door finisher.
3. Wiring harnesses tapping.
4. Door striker out of alignment causing a popping noise on starts and stops.

Tapping or moving the components or pressing on them while driving to duplicate the conditions can isolate many of these incidents. You can usually insulate the areas with felt cloth tape or insulator foam blocks from the Nissan Squeak and Rattle Kit (J-43980) to repair the noise.

# SQUEAK AND RATTLE TROUBLE DIAGNOSES

## TRUNK

Trunk noises are often caused by a loose jack or loose items put into the trunk by the owner. In addition look for:

1. Trunk lid dumpers out of adjustment.
2. Trunk lid striker out of adjustment.
3. Trunk lid torsion bars knocking together.
4. A loose license plate or bracket.

Most of these incidents can be repaired by adjusting, securing or insulating the item(s) or component(s) causing the noise.

## SUNROOF/HEADLINING

Noises in the sunroof/headlining area can often be traced to one of the following:

1. Sunroof lid, rail, linkage or seals making a rattle or light knocking noise.
2. Sunvisor shaft shaking in the holder.
3. Front or rear windshield touching headlining and squeaking.

Again, pressing on the components to stop the noise while duplicating the conditions can isolate most of these incidents. Repairs usually consist of insulating with felt cloth tape.

## SEATS

When isolating seat noise it's important to note the position the seat is in and the load placed on the seat when the noise is present. These conditions should be duplicated when verifying and isolating the cause of the noise.

Cause of seat noise include:

1. Headrest rods and holder.
2. A squeak between the seat pad cushion and frame.
3. Rear seatback lock and bracket.

These noises can be isolated by moving or pressing on the suspected components while duplicating the conditions under which the noise occurs. Most of these incidents can be repaired by repositioning the component or applying urethane tape to the contact area.

## UNDERHOOD

Some interior noise may be caused by components under the hood or on the engine wall. The noise is then transmitted into the passenger compartment.

Causes of transmitted underhood noise include:

1. Any component mounted to the engine wall.
2. Components that pass through the engine wall.
3. Engine wall mounts and connectors.
4. Loose radiator mounting pins.
5. Hood bumpers out of adjustment.
6. Hood striker out of adjustment.

These noises can be difficult to isolate since they cannot be reached from the interior of the vehicle. The best method is to secure, move or insulate one component at a time and test drive the vehicle. Also, engine RPM or load can be changed to isolate the noise. Repairs can usually be made by moving, adjusting, securing, or insulating the component causing the noise.

A

B

C

D

E

F

G

H

RF

J

K

L

M

# SQUEAK AND RATTLE TROUBLE DIAGNOSES

## Diagnostic Worksheet

AIS0038R

### SQUEAK & RATTLE DIAGNOSTIC WORKSHEET

Dear Nissan Customer:

We are concerned about your satisfaction with your Nissan vehicle. Repairing a squeak or rattle sometimes can be very difficult. To help us fix your Nissan right the first time, please take a moment to note the area of the vehicle where the squeak or rattle occurs and under what conditions. You may be asked to take a test drive with a service advisor or technician to ensure we confirm the noise you are hearing.

#### I. WHERE DOES THE NOISE COME FROM? (circle the area of the vehicle)

The illustrations are for reference only, and may not reflect the actual configuration of your vehicle.

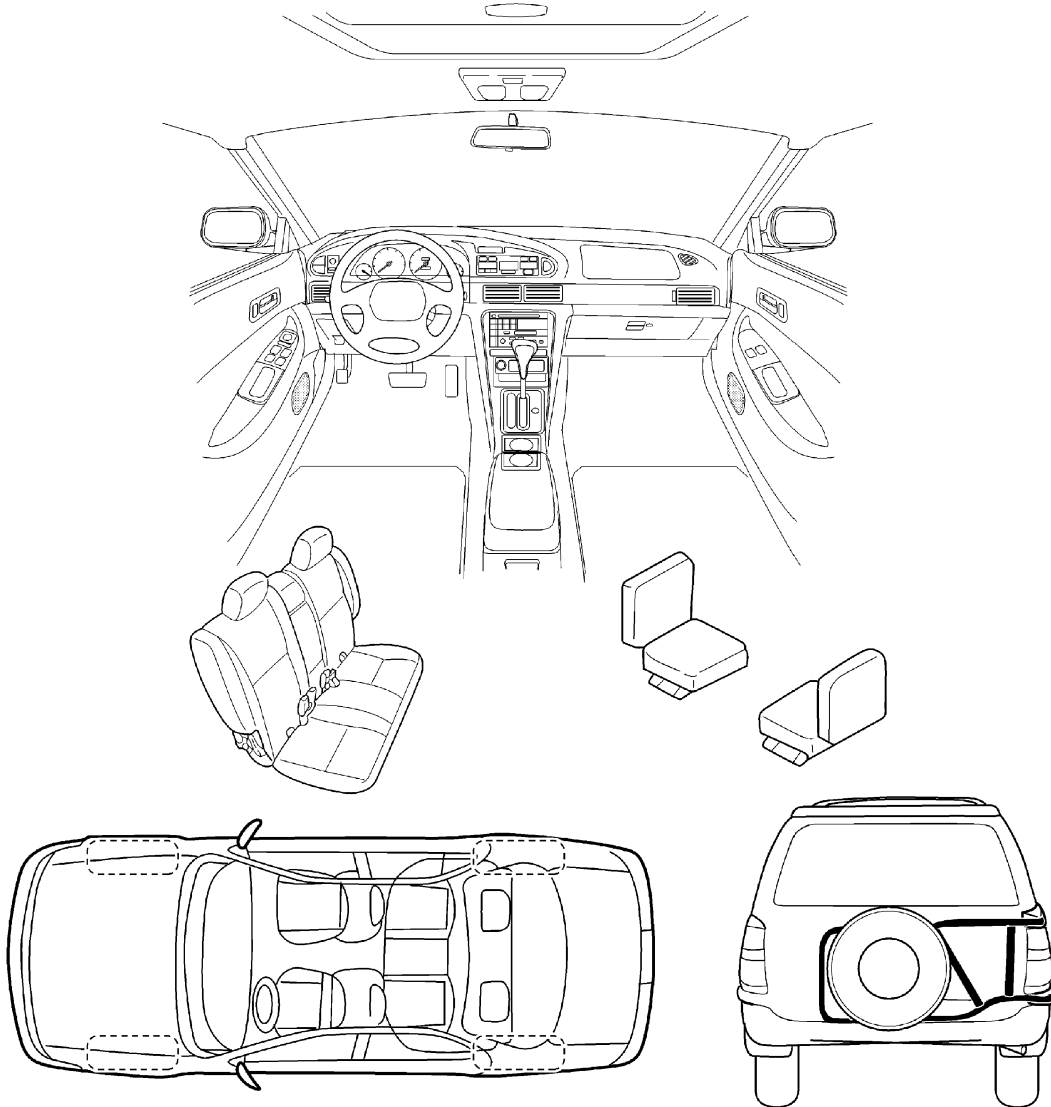

Continue to the back of the worksheet and briefly describe the location of the noise or rattle. In addition, please indicate the conditions which are present when the noise occurs.

PIIB0723E



# SQUEAK AND RATTLE TROUBLE DIAGNOSES

## SQUEAK & RATTLE DIAGNOSTIC WORKSHEET- page 2

Briefly describe the location where the noise occurs:

---

---

---

### II. WHEN DOES IT OCCUR? (check the boxes that apply)

- |  |   |
|--|---|
| <input type="checkbox"/> anytime                             | <input type="checkbox"/> after sitting out in the sun |
| <input type="checkbox"/> 1 <sup>st</sup> time in the morning | <input type="checkbox"/> when it is raining or wet    |
| <input type="checkbox"/> only when it is cold outside        | <input type="checkbox"/> dry or dusty conditions      |
| <input type="checkbox"/> only when it is hot outside         | <input type="checkbox"/> other: _____                 |

### III. WHEN DRIVING:

- through driveways
- over rough roads
- over speed bumps
- only at about \_\_\_\_ mph
- on acceleration
- coming to a stop
- on turns : left, right or either (circle)
- with passengers or cargo
- other: \_\_\_\_\_
- after driving \_\_\_\_ miles or \_\_\_\_ minutes

### IV. WHAT TYPE OF NOISE?

- squeak (like tennis shoes on a clean floor)
- creak (like walking on an old wooden floor)
- rattle (like shaking a baby rattle)
- knock (like a knock on a door)
- tick (like a clock second hand)
- thump (heavy, muffled knock noise)
- buzz (like a bumble bee)

### TO BE COMPLETED BY DEALERSHIP PERSONNEL

#### Test Drive Notes:

---

---

	YES	NO	Initials of person performing
Vehicle test driven with customer	<input type="checkbox"/>	<input type="checkbox"/>	_____
- Noise verified on test drive	<input type="checkbox"/>	<input type="checkbox"/>	_____
- Noise source located and repaired	<input type="checkbox"/>	<input type="checkbox"/>	_____
- Follow up test drive performed to confirm repair	<input type="checkbox"/>	<input type="checkbox"/>	_____

VIN: \_\_\_\_\_ Customer Name: \_\_\_\_\_

W.O. #: \_\_\_\_\_ Date: \_\_\_\_\_

**This form must be attached to Work Order**

SBT844

# SUNROOF

## SUNROOF

PFP:91210

### Component Parts and Harness Connector Location

AIS002E2

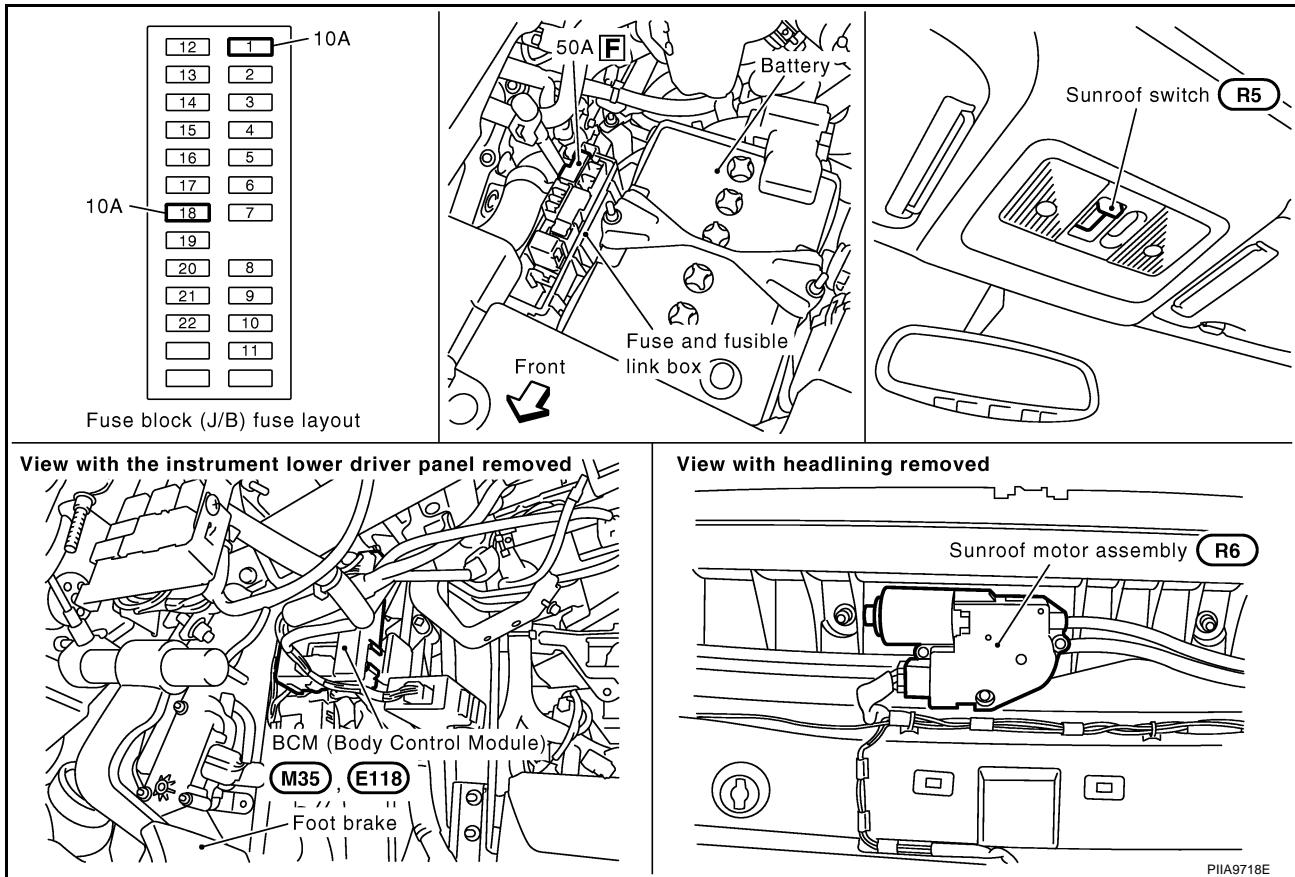

### System Description

AIS002E3

The thing to adjust the position of sunroof slide position in six stages by the thing to operate preselect switch can be done.

Power supplied at all time

- through 50A fusible link (letter **F**, located in the fuse and fusible link box.)
- to BCM terminal 55.
- through 10A fuse [No. 18, located in the fuse block (J/B)]
- to BCM terminal 42.
- through BCM terminal 54
- to sunroof motor assembly terminal 7.

With ignition switch ON or START position,  
Power is supplied

- through 10A fuse [No.1, located in the fuse block (J/B)]
- to BCM terminal 38
- though BCM terminal 53
- to sunroof motor assembly terminal 9.

Ground is supplied

- to BCM terminal 52.
- through body ground E13, E28 and E26.
- to sunroof motor assembly terminal 10
- through body ground M14 and M78.

# SUNROOF

## SUNROOF OPERATION

The ground is supplied to the terminals 1, 2, 3, 4 and 5 of sunroof motor assembly by combining the 1, 2, 3, 4, 5 and 6 terminals of sunroof switch.

Sunroof motor assembly operates sunroof in TILT or SLIDE by combining signals of the 1, 2, 3, 4 and 5 terminals.

Ground is supplied

- to sunroof switch terminal 6
- through body ground M14 and M78.

## SUNROOF SWITCH READING FUNCTION

1. Description
  - Sunroof switch reads sunroof switch status, and controls various electrical components according to the results.
  - Sunroof switch reads information of 8 switches by combining five terminals.
2. Sunroof motor assembly - Operation table of sunroof switch  
 Reads operation status of sunroof switch by the combination shown in the table.

TERMINAL	CONDITION ITEM	TILT UP	TILT DOWN	FULL CLOSE	SLIDE POSITION 1	SLIDE POSITION 2	SLIDE POSITION 3	SLIDE POSITION 4	FULL OPEN
		1	BIT 0 SIGNAL					○	○
2	BIT 1 SIGNAL			○	○	○			
3	BIT 2 SIGNAL			○				○	○
4	BIT 3 SIGNAL		○						
5	BIT 4 SIGNAL	○							
6	GROUND	○	○	○	○	○	○	○	○

PIIA4539E

## RETAINED POWER OPERATION

When the ignition switch is turned to "OFF" position from "ON" or "START" position, power is supplied for 45 seconds.

- to sunroof motor assembly terminal 9
- from BCM terminal 53.

When power is supplied, the sunroof can be operated.

The retained power operation is canceled when the driver or passenger side door is opened.

RAP signal period can be changed by CONSULT-II. Refer to [RF-18, "CONSULT-II Function \(BCM\)"](#).

# SUNROOF

---

## ANTI-PINCH FUNCTION

The CPU of sunroof motor monitors the sunroof motor operation and the sunroof position (fully-closed or other) by the signals from sunroof motor.

When sunroof motor detects an interruption during the following slid close and tilt down operation, sunroof switch controls the motor for open and the sunroof will operate until full up position (when tilt down operate) or 125 mm (4.92 in) or more in an open direction (when slide close operate):

- close operation and tilt down when ignition switch is in the "ON" position
- close operation and tilt down during retained power operation.

## MEMORY RESET PROCEDURE

1. Please observe the following instructions while confirming the sunroof operation.

### NOTE:

Do not disconnect the electronic power while the sunroof is operating or within 5 seconds after the sunroof stops. (to wipe-out the memory of lid position and operating friction.)

2. Initialization of system should be conducted after the following conditions.
  - When the battery is out or connector is disconnected while sunroof is operating or within 5 seconds after sunroof stops.
  - When the sunroof motor is changed.
  - When an emergency handle is used.
  - When the sunroof does not operate normally. (Incomplete initialization conditions)

## INITIALIZATION PROCEDURE

If the sunroof does not close or open automatically, use the following procedure to return sunroof operation to normal.

1. Close the sunroof if it is not in the closed position. It may be necessary to repeatedly push the switch to close the sunroof.
2. Press and hold the TILT UP switch. Do not release the switch, keep pressure on it. After 10 seconds of depressing, the sunroof will tilt up, then tilt down. Release the button.
3. Press and hold the TILT UP switch again. Do not release the switch, keep pressure on it. While depressing the switch, the sunroof will "Slide open" "Slide close" "Tilt up" "Tilt down". Release the button after the sunroof "Tilts down" and stops.
4. Initializing procedure is complete. Confirm proper operation of the sunroof (slide open, slide close, tilt up, tilt down.)

## CAN Communication System Description

AIS004UQ

CAN (Controller Area Network) is a serial communication line for real time application. It is an on-vehicle multiplex communication line with high data communication speed and excellent error detection ability. Many electronic control units are equipped onto a vehicle, and each control unit shares information and links with other control units during operation (not independent). In CAN communication, control units are connected with 2 communication lines (CAN H line, CAN L line) allowing a high rate of information transmission with less wiring. Each control unit transmits/receives data but selectively reads required data only.

## CAN Communication Unit

AIS004UR

Refer to [LAN-29, "CAN Communication Unit"](#)

A

B

C

D

E

F

G

H

RF

J

K

L

M

# SUNROOF

AIS002E4

## Wiring Diagram — SROOF —

### RF-SROOF-01

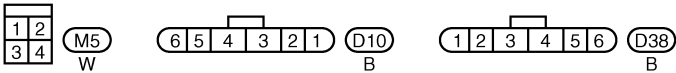
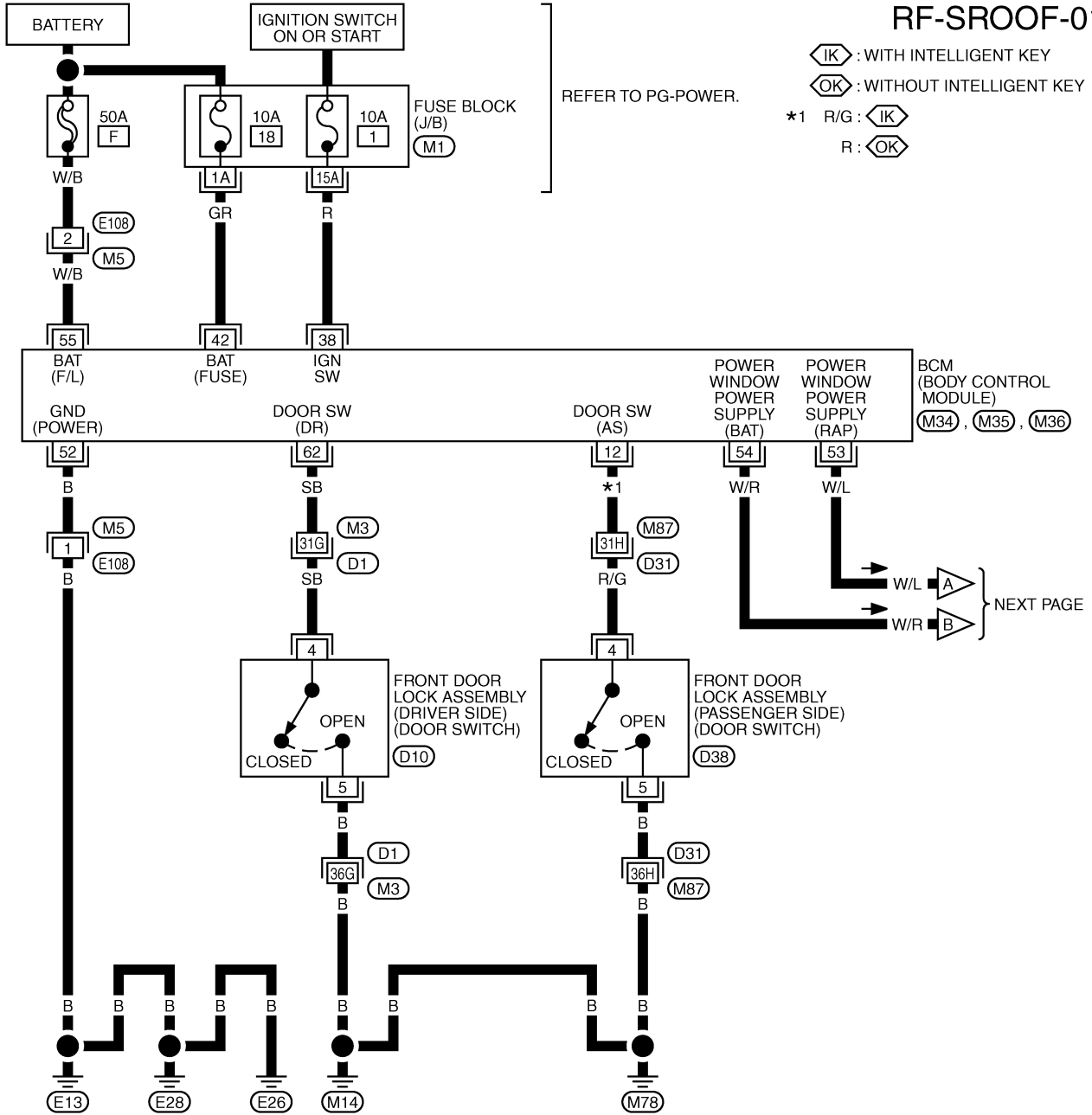

REFER TO THE FOLLOWING.

(D1), (D31) -SUPER MULTIPLE JUNCTION (SMJ)

(M1) -FUSE BLOCK-JUNCTION BOX (J/B)

(M34), (M35), (M36) -ELECTRICAL UNITS

TIWB0181E

# SUNROOF

RF-SROOF-02

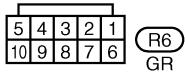
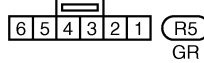
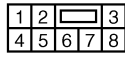
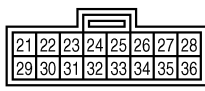
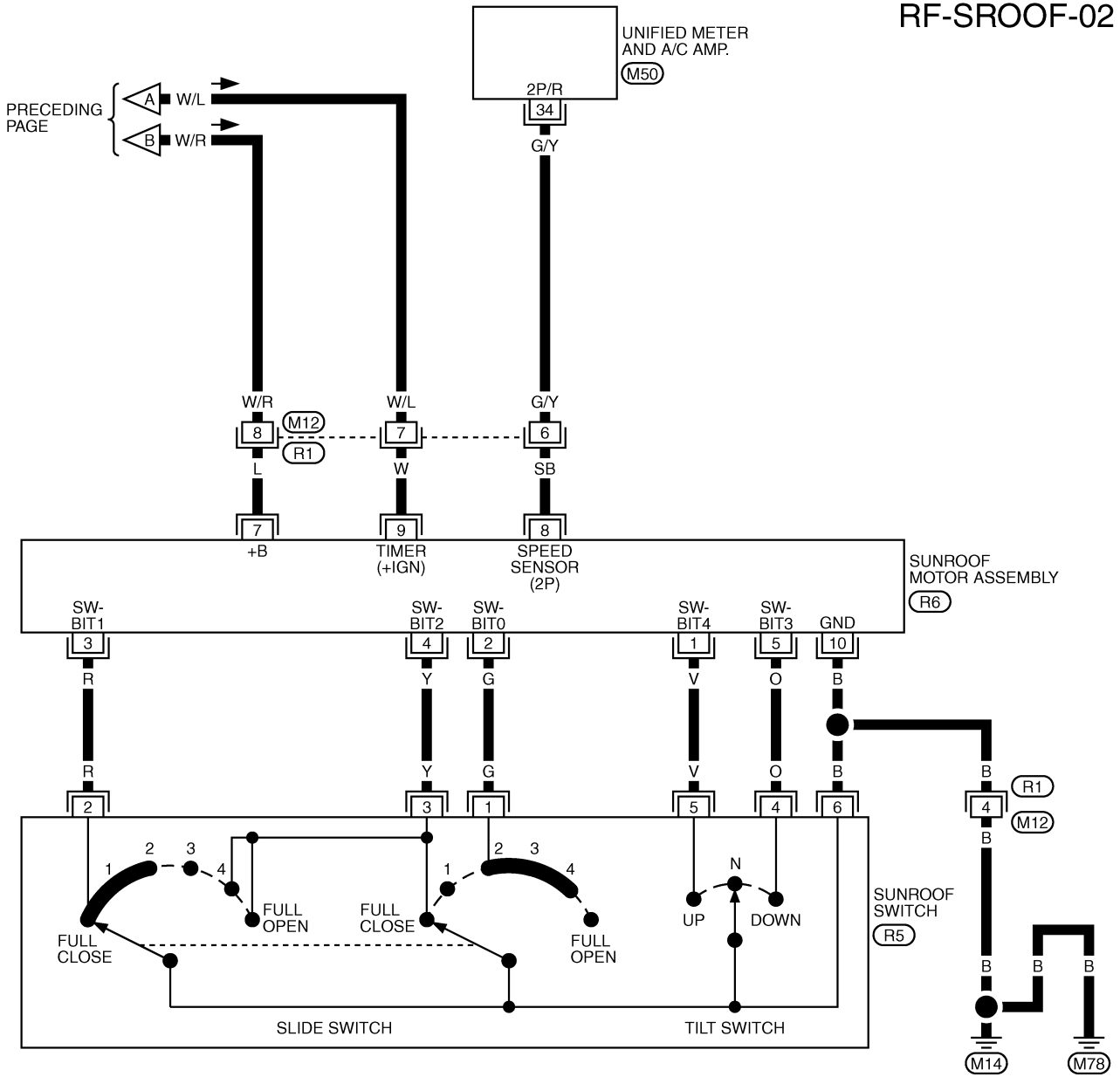

TIWA0302E

# SUNROOF

## Terminals and Reference Value for BCM

AI S002E5

Terminal	Wire color	Item	Condition	Voltage (V) (Approx.)
12	R/G (R)	Front door switch passenger side	OPEN (ON)	0
			CLOSE (OFF)	Battery voltage
38	G	Ignition switch ON or START	Ignition switch (ON or START position)	Battery voltage
42	GR	Battery power supply	—	Battery voltage
52	B	Ground (power)	—	0
53	W/L	RAP signal	Ignition switch ON	Battery voltage
			Within 45 seconds after ignition switch is turned to OFF position	Battery voltage
			Within approx.45 seconds after ignition switch OFF while front door LH or RH is open	0
54	W/R	Power window power supply	—	Battery voltage
55	W/B	Battery power supply	—	Battery voltage
62	SB	Front door switch driver side	OPEN (ON)	0
			CLOSE (OFF)	Battery voltage

():Models without intelligent key

## Terminals and Reference Value for Sunroof Motor Assembly

AI S002E6

Terminal	Wire color	Item	Condition	Voltage (V) (Approx.)
1	V	Sunroof switch (BIT 4) signal	Sunroof switch in following position ● TILT UP	0
			Other than above	Battery voltage
2	G	Sunroof switch (BIT 0) signal	Sunroof switch in following position ● SLIDE POSITION 2 ● SLIDE POSITION 3 ● SLIDE POSITION 4	0
			Other than above	Battery voltage
3	R	Sunroof switch (BIT 1) signal	Sunroof switch in following position ● FULL CLOSE ● SLIDE POSITION 1 ● SLIDE POSITION 2	0
			Other than above	Battery voltage
4	Y	Sunroof switch (BIT 2) signal	Sunroof switch in following position ● FULL CLOSE ● FULL OPEN ● SLIDE POSITION 4	0
			Other than above	Battery voltage
5	O	Sunroof switch (BIT 3) signal	Sunroof switch in following position ● TILT DOWN	0
			Other than above	Battery voltage
7	L	Power window power supply	—	Battery voltage

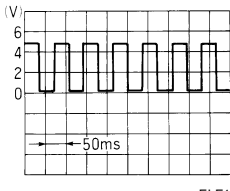

# SUNROOF

Terminal	Wire color	Item	Condition	Voltage (V) (Approx.)
8	SB	Vehicle speed signal (2-pulse)	Speedometer operated [When vehicle speed is approx.40km/ h (25MPH)]	
9	W	RAP signal	Ignition switch ON	Battery voltage
			Within 45 seconds after ignition switch is turned to OFF position	Battery voltage
			Within approx.45 seconds after ignition switch OFF while front door LH or RH is open	0
10	B	Ground	—	0

## Work Flow

AIS002E7

1. Check the symptom and customer's requests.
2. Understand the outline of system. Refer to [RF-10, "System Description"](#) .
3. According to the trouble diagnosis chart, repair or replace the cause of the malfunction. Refer to [RF-20, "Trouble Diagnosis Chart by Symptom"](#) .
4. Does power window system operate normally? If Yes, GO TO 5, If No, GO TO 3.
5. INSPECTION END.

RF

# SUNROOF

AI/S002E9

## CONSULT-II Function (BCM)

### CAUTION:

If CONSULT-II is used with no connection of CONSULT-II CONVERTER, malfunction might be detected in self-diagnosis depending on control unit which carry out CAN communication.

### “RETAINED PWR”

1. Turn ignition switch “OFF”.
2. Connect “CONSULT-II” to the data link connector.

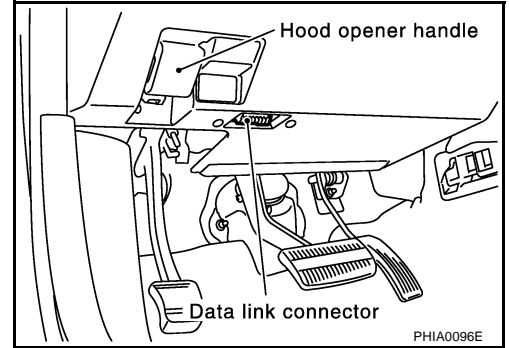

3. Turn ignition switch “ON”.
4. Touch “START (NISSAN BASED VHCL)”.

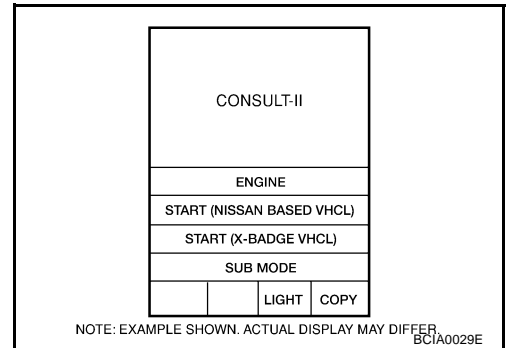

5. Touch “BCM”.
- If “BCM” is not indicated, go to Refer to “CONSULT-II Data Link Connector (DLC) Circuit”.

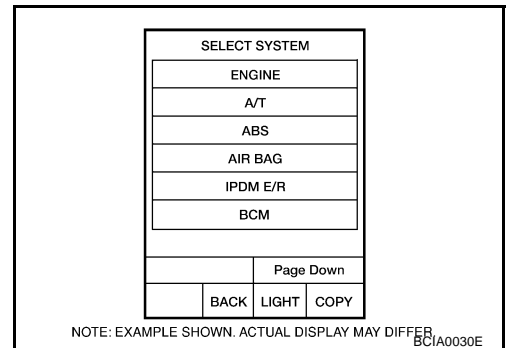

6. Touch “RETAINED PWR”.

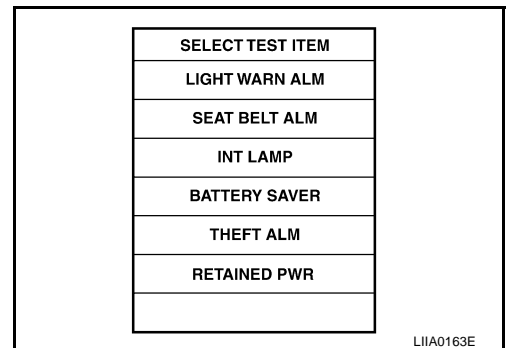

# SUNROOF

7. Select diagnosis mode. "DATA MONITOR", "ACTIVE TEST" and "WORK SUPPORT" are available.

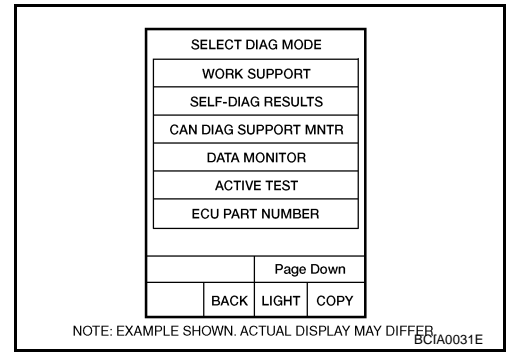

A  
B  
C  
D  
E  
F  
G  
H  
RF  
J  
K  
L  
M

## Data Monitor

AIS002EA

Monitored item	Description
IGN ON SW	Indicates [ON/OFF] condition of ignition switch.
DOOR SW-DR	Indicates [ON/OFF] condition of driver side door switch.
DDOR SW-AS	Indicates [ON/OFF] condition of passenger side door switch.

## Active Test

AIS002EB

Test item	Description
RETAINED PWR	<p>This test is able to supply RAP signal (power) from BCM to power window system and power sunroof system. Those systems can be operated when turning on "RETAINED PWR" on CONSULT-II screen even if the ignition switch is turned OFF.</p> <p><b>NOTE:</b> During this test, CONSULT-II can be operated with ignition switch in "OFF" position. "RETAINED PWR" should be turned "ON" or "OFF" on CONLUSt-II screen when ignition switch in ON. Then turn ignition switch OFF for checking retained power operation. CONSULT-II might be stuck if "RETAINED PWR" is turned to "ON" or "OFF" on CONSULT-II screen when ignition switch is OFF.</p>

## Work Support

AIS002EC

Work item	Description
RETAINED PWR SET	<p>RAP signal's power supply period can be changed by mode setting. Selects RAP signal's power supply period between two steps.</p> <ul style="list-style-type: none"> <li>● MODE 1 (45 sec.) / MODE 2 (OFF) / MODE 3 (2 min.)</li> </ul>

# SUNROOF

## Trouble Diagnosis Chart by Symptom

AIS002ED

Symptom	Diagnostic procedure and repair order	Refer to page
Sunroof does not operate.	1. BCM power supply and ground circuit check.	<a href="#">RF-20</a>
	2. Sunroof motor assembly power supply and ground circuit check.	<a href="#">RF-22</a>
	3. Sunroof switch circuit check 9.	<a href="#">RF-29</a>
	4. Replace the sunroof motor assembly.	<a href="#">RF-44</a>
Sunroof alone does not go to full close position.	1. Sunroof switch circuit check 1.	<a href="#">RF-24</a>
Sunroof alone does not go to slide position 1.	1. Sunroof switch circuit check 2.	<a href="#">RF-25</a>
Sunroof alone does not go to slide position 2.	1. Sunroof switch circuit check 3.	<a href="#">RF-25</a>
Sunroof alone does not go to slide position 3.	1. Sunroof switch circuit check 4.	<a href="#">RF-26</a>
Sunroof alone does not go to slide position 4.	1. Sunroof switch circuit check 5.	<a href="#">RF-27</a>
Sunroof alone does not go to full open position.	1. Sunroof switch circuit check 6.	<a href="#">RF-27</a>
Sunroof alone does not operate tilt up.	1. Sunroof switch circuit check 7.	<a href="#">RF-28</a>
Sunroof alone does not operate tilt down.	1. Sunroof switch circuit check 8.	<a href="#">RF-29</a>
Sunroof does not go to slide position 2, 3 and 4.	1. Sunroof switch circuit check 10.	<a href="#">RF-31</a>
Sunroof does not go to full closed and slide position 1, 2.	1. Sunroof switch circuit check 11.	<a href="#">RF-32</a>
Sunroof does not go to full close, full open and slide position 4.	1. Sunroof switch circuit check 12.	<a href="#">RF-33</a>
Retained power operation does not operate properly.	1. Check the retained power operation mode setting.	<a href="#">RF-18</a>
	2. Door switch check.	<a href="#">RF-34</a>
	3. BCM check.	<a href="#">RF-23</a>
	4. Replace sunroof motor assembly.	<a href="#">RF-44</a>
Motor does not stop at the sunroof fully -open or fully-closed position.	1. Initialization procedure check.	<a href="#">RF-12</a>
	2. Replace the sunroof motor assembly.	<a href="#">RF-44</a>
Sunroof does not do the interruption detection.	1. Replace the sunroof motor assembly.	<a href="#">RF-44</a>

## BCM Power Supply and Ground Circuit Check

AIS00350

First perform the "SELF-DIAG RESULTS" in "BCM" with CONSULT-II, then perform the each trouble diagnosis of malfunction system indicated "SELF-DIAG RESULTS" of "BCM". Refer to [BCS-15, "CAN Communication Inspection Using CONSULT-II \(Self-Diagnosis\)"](#) .

### 1. CHECK FUSE

- Check 10A fuse [No.1, located in fuse block (J/B)]
- Check 10A fuse [No. 18, located in fuse block (J/B)]
- Check 50A fusible link (letter F, located in the fuse and fusible link box).

#### NOTE:

Refer to [RF-10, "Component Parts and Harness Connector Location"](#) .

#### OK or NG

OK >> GO TO 2.

NG >> If fuse is blown, be sure to eliminate cause of malfunction before installing new fuse. Refer to [PG-3, "POWER SUPPLY ROUTING CIRCUIT"](#)

# SUNROOF

## 2. CHECK POWER SUPPLY CIRCUIT

1. Turn ignition switch ON.
2. Check voltage between BCM connectors M34, M35 terminals 38, 42, 55 and ground.

**38 (R) – Ground : Battery voltage**

**42 (GR) – Ground : Battery voltage**

**55 (W/B) – Ground : Battery voltage**

OK or NG

OK >> GO TO 3.

NG >> Check BCM power supply circuit for open or short.

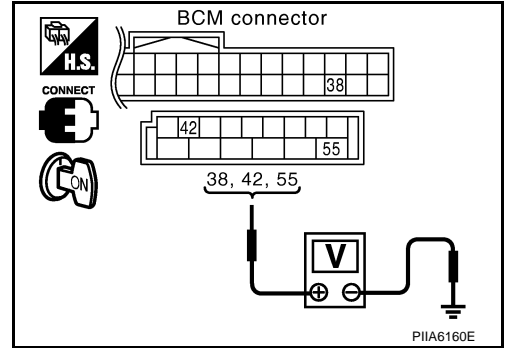

## 3. CHECK GROUND CIRCUIT

1. Turn ignition switch OFF.
2. Disconnect BCM connector.
3. Check continuity between BCM connector M35 terminals 52 and ground.

**52 (B) – Ground : Continuity should exist.**

OK or NG

OK >> BCM power supply and ground circuit is OK.

NG >> Check BCM ground circuit for open or short.

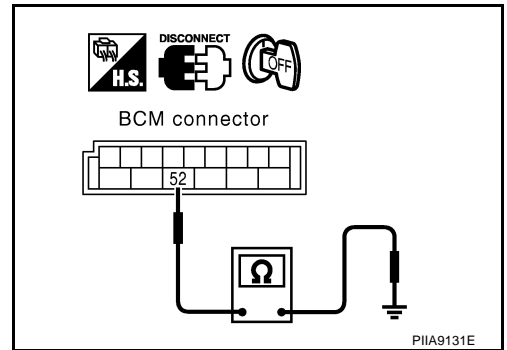

A  
B  
C  
D  
E  
F  
G  
H  
RF  
J  
K  
L  
M

# SUNROOF

## Sunroof Motor Assembly Power Supply and Ground Circuit Check

AI5002EE

### 1. CHECK POWER SUPPLY CIRCUIT

1. Turn ignition switch ON.
2. Check voltage between sunroof motor assembly connector R6 terminals 7, 9 and ground.

**7 (L) – Ground : Battery voltage**  
**9 (W) – Ground : Battery voltage**

OK or NG

OK >> GO TO 2.  
NG >> GO TO 3.

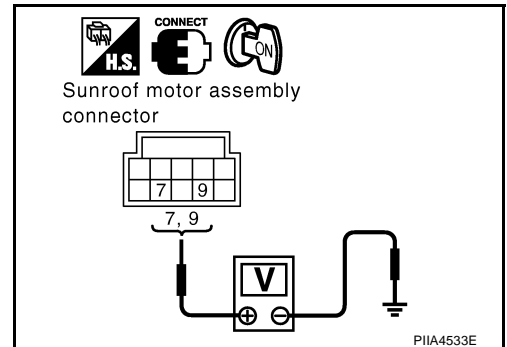

### 2. CHECK GROUND CIRCUIT

1. Turn ignition switch OFF.
2. Disconnect sunroof motor assembly connector.
3. Check continuity between sunroof motor assembly connector R6 terminal 10 and ground.

**10 (B) – Ground : Continuity should exist.**

OK or NG

OK >> Sunroof motor assembly power supply and ground circuit are OK. Further inspection is necessary. Refer to symptom chart.  
NG >> Repair or replace harness.

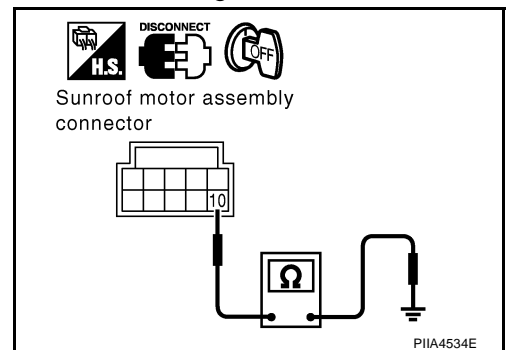

### 3. CHECK SUNROOF MOTOR ASSEMBLY POWER SUPPLY CIRCUIT

1. Turn ignition switch OFF.
2. Disconnect BCM and sunroof motor assembly connector.
3. Check continuity between BCM connector M35 terminals 53, 54 and sunroof motor assembly connector R6 terminals 7, 9.

**53 (W/L) – 9 (W) : Continuity should exist.**  
**54 (W/R) – 7 (L) : Continuity should exist.**

4. Check continuity between BCM connector M35 terminals 53, 54 and ground.

**53 (W/L) – Ground : Continuity should not exist.**  
**54 (W/R) – Ground : Continuity should not exist.**

OK or NG

OK >> GO TO 4.  
NG >> Repair or replace harness.

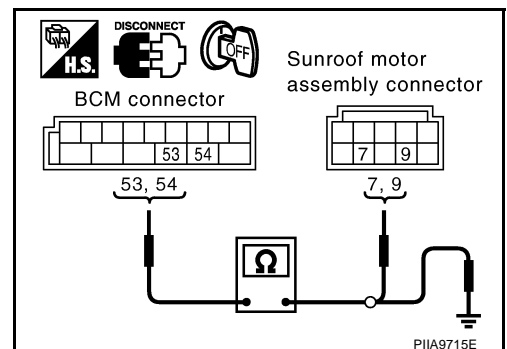

# SUNROOF

## 4. CHECK BCM OUTPUT SIGNAL

1. Connect BCM connector.
2. Turn ignition switch ON.
3. Check voltage between BCM connector M35 terminals 53, 54 and ground.

**53 (W/L) – Ground : Battery voltage**

**54 (W/R) – Ground : Battery voltage**

OK or NG

OK >> Check condition of the harness and the connector.

NG >> Replace BCM.

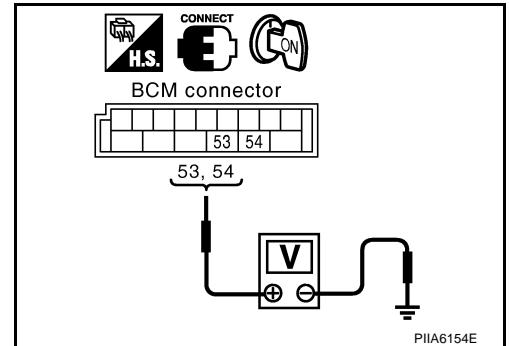

## BCM Check

### 1. CHECK RETAINED POWER INPUT SIGNAL

Check voltage between sunroof motor assembly connector and ground.

Con- nector	Terminals (Wire color)		Condition	Voltage (V) (Approx.)
	(+)	(-)		
R6	9 (W)	Ground	Ignition switch ON	Battery voltage
			Within 45 seconds after ignition switch in turned to OFF position	Battery voltage
			Within approx.45 seconds after ignition switch OFF while front door LH or RH is open	0

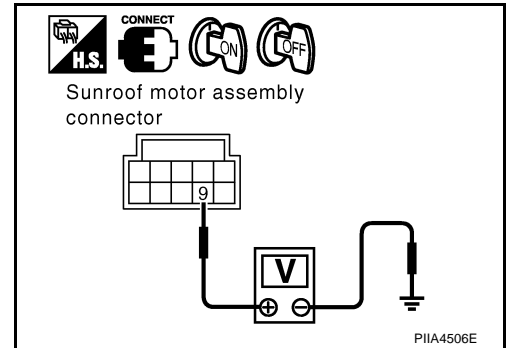

OK or NG

OK >> Retained power operation input signal is OK.

NG >> GO TO 2.

### 2. CHECK HARNESS CONTINUITY

1. Turn ignition switch OFF.
2. Disconnect BCM and sunroof motor assembly connector.
3. Check continuity between BCM connector M35 terminal 53 and sunroof motor assembly connector R6 terminal 9.

**53 (W/L) – 9 (W) : Continuity should exist.**

4. Check continuity between BCM connector M35 terminal 53 and ground.

**53 (W/L) – Ground : Continuity should not exist.**

OK or NG

OK >> GO TO 3.

NG >> Repair or replace harness between BCM and sunroof motor assembly.

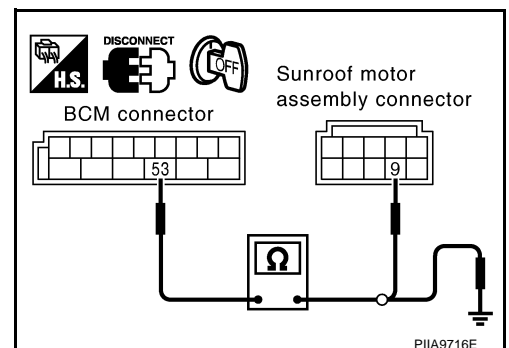

# SUNROOF

## 3. CHECK RETAINED POWER OUTPUT SIGNAL

1. Connect BCM connector.
2. Check voltage between BCM connector and ground.

Con- nector	Terminals (Wire color)		Condition	Voltage (V) (Approx.)
	(+)	(-)		
M35	53 (W/L)	Ground	Ignition switch ON	Battery voltage
			Within 45 seconds after ignition switch in turned to OFF position	Battery voltage
			Within approx.45 seconds after ignition switch OFF while front door LH or RH is open	0

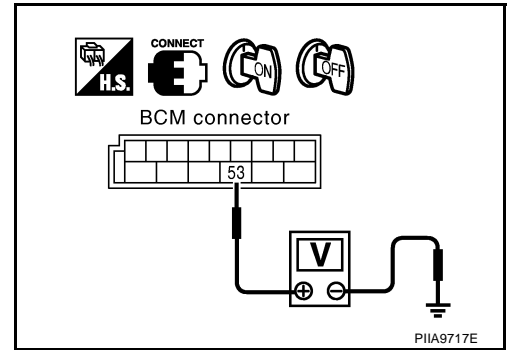

OK or NG

- OK >> Check condition of the harness and the connector.  
 NG >> Replace BCM.

## Sunroof Switch Circuit Check 1

AIS002K9

### 1. CHECK SUNROOF SWITCH

1. Turn ignition switch OFF.
2. Disconnect sunroof switch connector.
3. Check continuity between sunroof switch terminals 2, 3 and 6.

Terminals		Condition	Continuity
2 3	6	Slide switch FULL CLOSE position	Yes
		Other than above	No

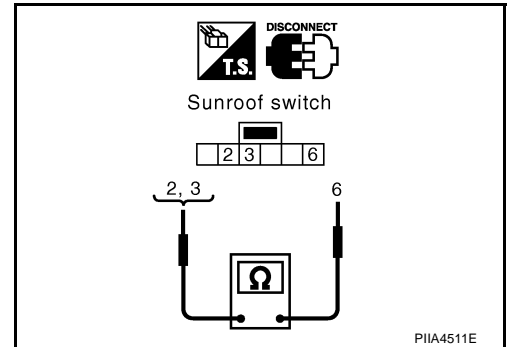

OK or NG

- OK >> GO TO 2.  
 NG >> Replace sunroof switch.

### 2. CHECK SUNROOF SWITCH OUTPUT SIGNAL

1. Connect sunroof motor connector.
2. Turn ignition switch ON.
3. Check voltage between sunroof motor assembly connector and ground.

Con- nector	Terminals (Wire color)		Condition	Voltage (V) (Approx.)
	(+)	(-)		
R6	3 (R) 4 (Y)	Ground	Slide switch FULL CLOSE position	0
			Other than above	Battery voltage

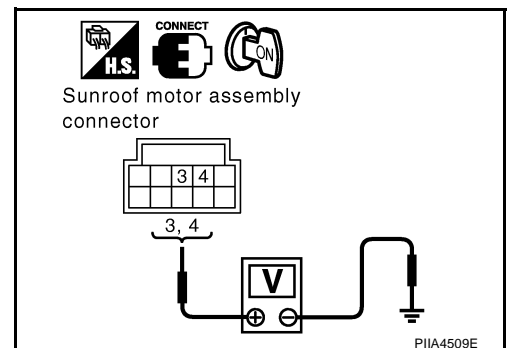

OK or NG

- OK >> Replace sunroof motor assembly.  
 NG >> Check the condition of the harness and the connector.



# SUNROOF

AIS002KA

## Sunroof Switch Circuit Check 2

### 1. CHECK SUNROOF SWITCH

1. Turn ignition switch OFF.
2. Disconnect sunroof switch connector.
3. Check continuity between sunroof switch terminals 2 and 6.

Terminals		Condition	Continuity
2	6	Slide switch SLIDE POSITION 1	Yes
		Other than above	No

#### OK or NG

- OK >> GO TO 2.  
 NG >> Replace sunroof switch.

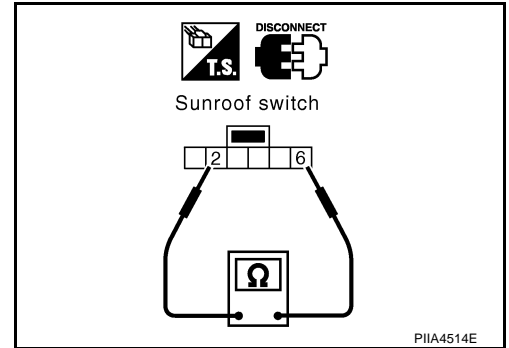

### 2. CHECK SUNROOF SWITCH OUTPUT SIGNAL

1. Connect sunroof switch connector.
2. Turn ignition switch ON.
3. Check voltage between sunroof motor assembly connector and ground.

Con- nector	Terminals (Wire color)		Condition	Voltage (V) (Approx.)
	(+)	(-)		
R6	3 (R)	Ground	Slide switch SLIDE POSITION 1	0
			Other than above	Battery voltage

#### OK or NG

- OK >> Replace sunroof motor assembly.  
 NG >> Check the condition of the harness and the connector.

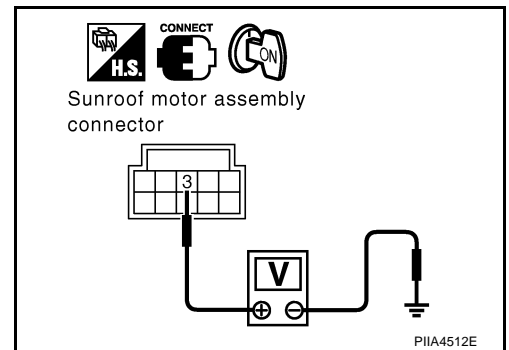

## Sunroof Switch Circuit Check 3

AIS002KB

### 1. CHECK SUNROOF SWITCH

1. Turn ignition switch OFF.
2. Disconnect sunroof switch connector.
3. Check continuity between sunroof switch terminals 1, 2 and 6.

Terminals		Condition	Continuity
1 2	6	Slide switch FULL CLOSE position	Yes
		Other than above	No

#### OK or NG

- OK >> GO TO 2.  
 NG >> Replace sunroof switch.

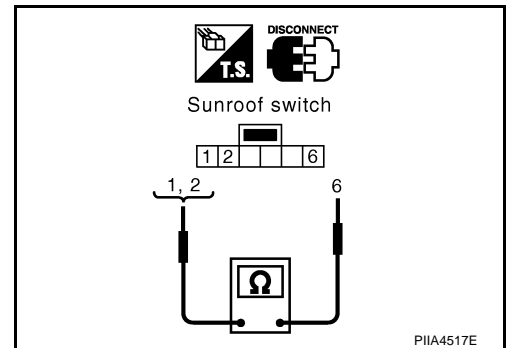

# SUNROOF

## 2. CHECK SUNROOF SWITCH OUTPUT SIGNAL

1. Connect sunroof switch connector.
2. Turn ignition switch ON.
3. Check voltage between sunroof motor assembly connector and ground.

Con- nector	Terminals (Wire color)		Condition	Voltage (V) (Approx.)
	(+)	(-)		
R6	2 (G)	Ground	Slide switch SLIDE POSITION 2	0
	3 (R)		Other than above	Battery voltage

OK or NG

- OK >> Replace sunroof motor assembly.  
 NG >> Check the condition of the harness and the connector.

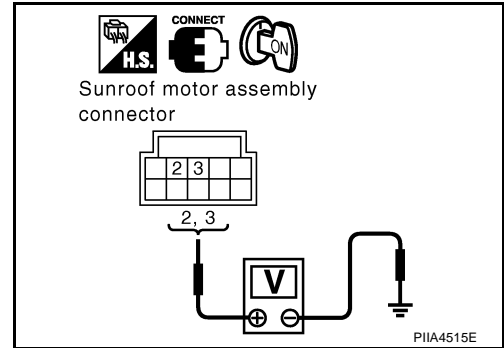

## Sunroof Switch Circuit Check 4

### 1. CHECK SUNROOF SWITCH

1. Turn ignition switch OFF.
2. Disconnect sunroof switch connector.
3. Check continuity between sunroof switch terminals 1 and 6.

Terminals		Condition	Continuity
1	6	Slide switch SLIDE POSITION 3	Yes
		Other than above	No

OK or NG

- OK >> GO TO 2.  
 NG >> Replace sunroof switch.

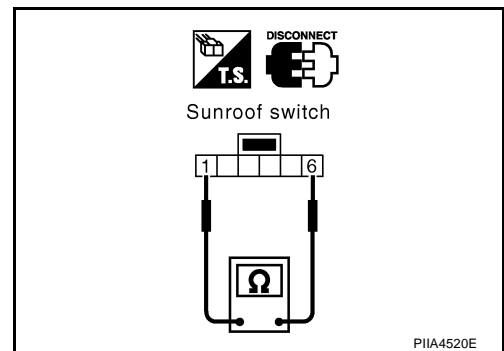

## 2. CHECK SUNROOF SWITCH OUTPUT SIGNAL

1. Connect sunroof switch connector.
2. Turn ignition switch ON.
3. Check voltage between sunroof motor assembly connector and ground.

Con- nector	Terminals (Wire color)		Condition	Voltage (V) (Approx.)
	(+)	(-)		
R6	2 (G)	Ground	Slide switch SLIDE POSITION 3	0
			Other than above	Battery voltage

OK or NG

- OK >> Replace sunroof motor assembly.  
 NG >> Check the condition of the harness and the connector.

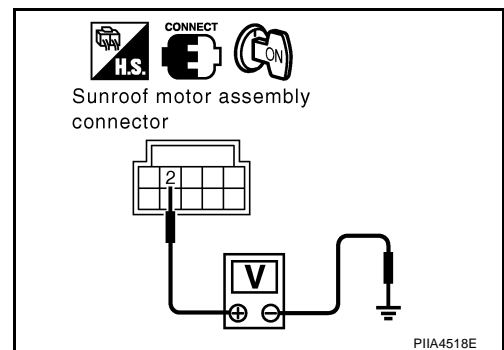

# SUNROOF

AIS002KD

## Sunroof Switch Circuit Check 5

### 1. CHECK SUNROOF SWITCH

1. Turn ignition switch OFF.
2. Disconnect sunroof switch connector.
3. Check continuity between sunroof switch terminals 1, 3 and 6.

Terminals		Condition	Continuity
1 3	6	Slide switch FULL CLOSE position	Yes
		Other than above	No

#### OK or NG

- OK >> GO TO 2.  
 NG >> Replace sunroof switch.

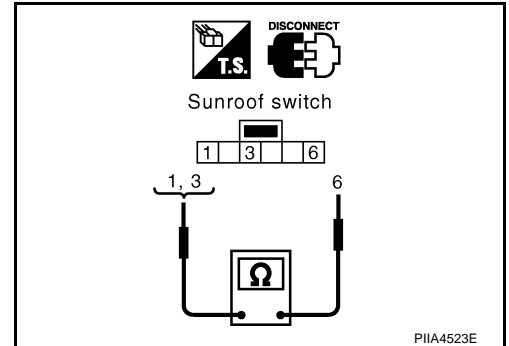

### 2. CHECK SUNROOF SWITCH OUTPUT SIGNAL

1. Connect sunroof switch connector.
2. Turn ignition switch ON.
3. Check voltage between sunroof motor assembly connector and ground.

Con- nector	Terminals (Wire color)		Condition	Voltage (V) (Approx.)
	(+)	(-)		
R6	2 (G) 4 (Y)	Ground	Slide switch SLIDE POSITION 4	0
			Other than above	Battery voltage

#### OK or NG

- OK >> Replace sunroof motor assembly.  
 NG >> Check the condition of the harness and the connector.

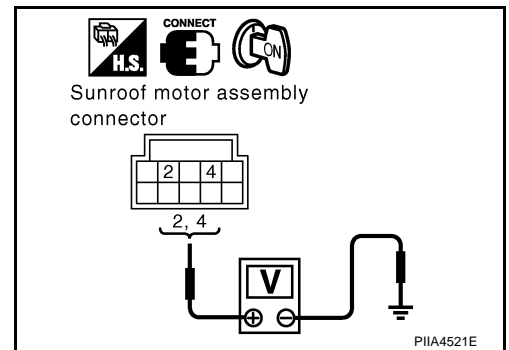

## Sunroof Switch Circuit Check 6

AIS002KE

### 1. CHECK SUNROOF SWITCH

1. Turn ignition switch OFF.
2. Disconnect sunroof switch connector.
3. Check continuity between sunroof switch terminals 3 and 6.

Terminals		Condition	Continuity
3	6	Slide switch FULL OPEN position	Yes
		Other than above	No

#### OK or NG

- OK >> GO TO 2.  
 NG >> Replace sunroof switch.

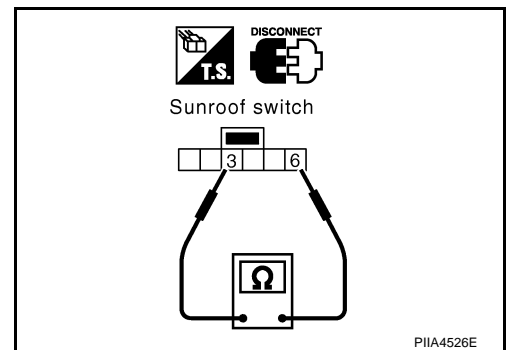

# SUNROOF

## 2. CHECK SUNROOF SWITCH OUTPUT SIGNAL

1. Connect sunroof switch connector.
2. Turn ignition switch ON.
3. Check voltage between sunroof motor assembly connector and ground.

Con- nector	Terminals (Wire color)		Condition	Voltage (V) (Approx.)
	(+)	(-)		
R6	4 (Y)	Ground	Slide switch FULL OPEN position	0
			Other than above	Battery voltage

OK or NG

- OK >> Replace sunroof motor assembly.  
 NG >> Check the condition of the harness and the connector.

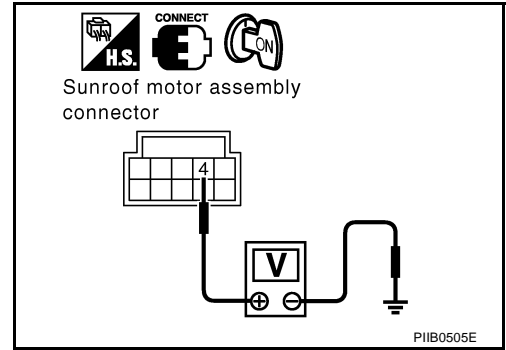

## Sunroof Switch Circuit Check 7

### 1. CHECK SUNROOF SWITCH

1. Turn ignition switch OFF.
2. Disconnect sunroof switch connector.
3. Check continuity between sunroof switch terminals 5 and 6.

Terminals		Condition	Continuity
5	6		
		Other than above	No

OK or NG

- OK >> GO TO 2.  
 NG >> Replace sunroof switch.

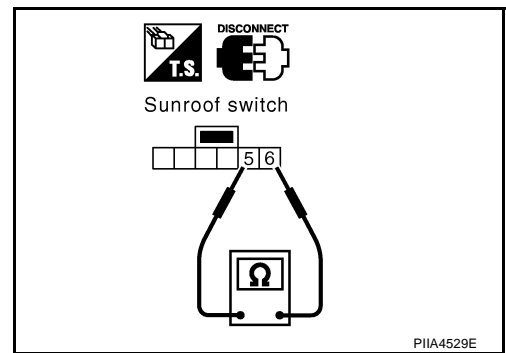

## 2. CHECK SUNROOF SWITCH OUTPUT SIGNAL

1. Connect sunroof switch connector.
2. Turn ignition switch ON.
3. Check voltage between sunroof motor assembly connector and ground.

Con- nector	Terminals (Wire color)		Condition	Voltage (V) (Approx.)
	(+)	(-)		
R6	1 (V)	Ground	Tilt switch UP position	0
			Other than above	Battery voltage

OK or NG

- OK >> Replace sunroof motor assembly.  
 NG >> Check the condition of the harness and the connector.

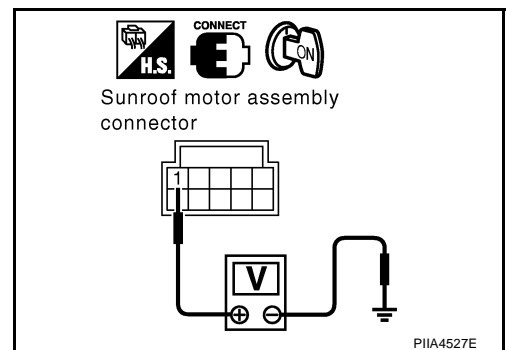

## Sunroof Switch Circuit Check 8

### 1. CHECK SUNROOF SWITCH

1. Turn ignition switch OFF.
2. Disconnect sunroof switch connector.
3. Check continuity between sunroof switch terminals 4 and 6.

Terminals		Condition	Continuity
4	6	Tilt switch UP position	Yes
		Other than above	No

#### OK or NG

- OK >> GO TO 2.  
 NG >> Replace sunroof switch.

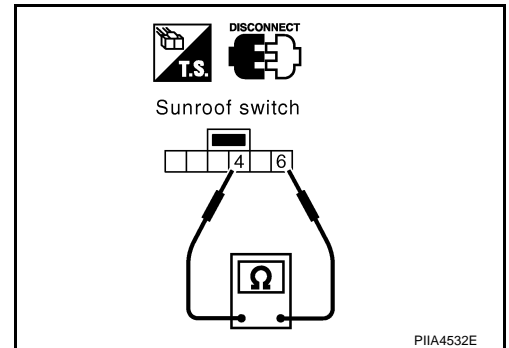

### 2. CHECK SUNROOF SWITCH OUTPUT SIGNAL

1. Connect sunroof switch connector.
2. Turn ignition switch ON.
3. Check voltage between sunroof motor assembly connector and ground.

Con- nector	Terminals (Wire color)		Condition	Voltage (V) (Approx.)
	(+)	(-)		
R6	5 (O)	Ground	Tilt switch DOWN position	0
			Other than above	Battery voltage

#### OK or NG

- OK >> Replace sunroof motor assembly.  
 NG >> Check the condition of the harness and the connector.

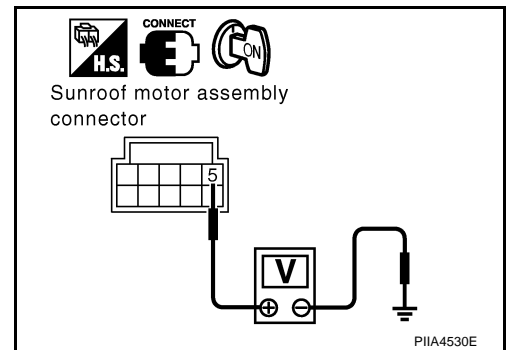

## Sunroof Switch Circuit Check 9

### 1. CHECK SUNROOF MOTOR OUTPUT SIGNAL

1. Turn ignition switch OFF.
2. Disconnect sunroof motor switch connector.
3. Turn ignition switch ON.
4. Check voltage between sunroof motor assembly connector R6 terminals 1, 2, 3, 4, 5 and ground.

- 1 (V) – Ground : Battery voltage**  
**2 (G) – Ground : Battery voltage**  
**3 (R) – Ground : Battery voltage**  
**4 (Y) – Ground : Battery voltage**  
**5 (O) – Ground : Battery voltage**

#### OK or NG

- OK >> GO TO 2  
 NG >> Replace sunroof motor assembly.

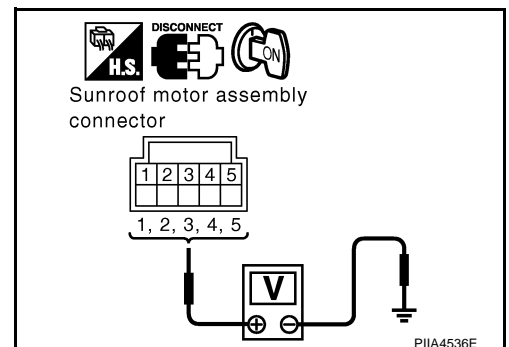

# SUNROOF

## 2. CHECK HARNESS CONTINUITY

1. Turn ignition switch OFF.
2. Disconnect sunroof switch connector.
3. Check continuity between sunroof motor assembly connector R6 terminals 1, 2, 3, 4, 5 and sunroof switch connector R5 terminals 1, 2, 3, 4, 5.

**1 (V) – 5 (V) : Continuity should exist.**  
**2 (G) – 1 (G) : Continuity should exist.**  
**3 (R) – 2 (R) : Continuity should exist.**  
**4 (Y) – 3 (Y) : Continuity should exist.**  
**5 (O) – 4 (O) : Continuity should exist.**

4. Check continuity between sunroof motor assembly connector R6 terminals 1, 2, 3, 4, 5 and ground.

**1 (V) – Ground : Continuity should not exist.**  
**2 (G) – Ground : Continuity should not exist.**  
**3 (R) – Ground : Continuity should not exist.**  
**4 (Y) – Ground : Continuity should not exist.**  
**5 (O) – Ground : Continuity should not exist.**

OK or NG

- OK >> GO TO 3.  
NG >> Repair or replace harness.

## 3. CHECK GROUND CIRCUIT

Check continuity between sunroof switch connector R5 terminal 6 and ground.

**6 (B) – Ground : Continuity should exist.**

OK or NG

- OK >> Check condition of the harness and the connector.  
NG >> Repair or replace harness.

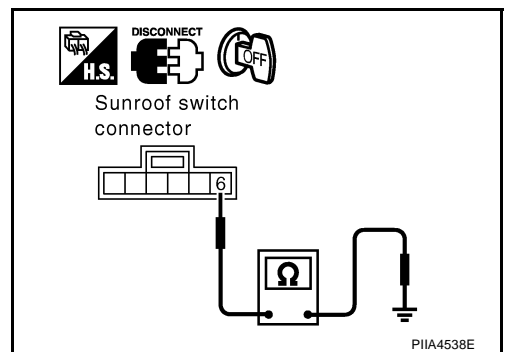
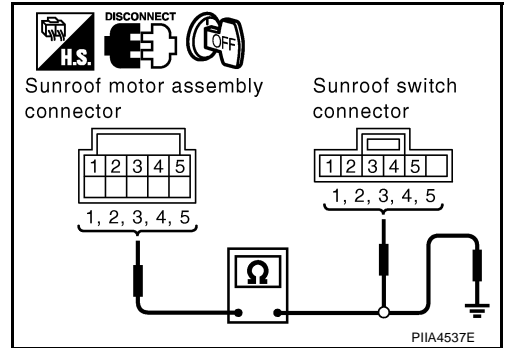

# SUNROOF

AIS00351

## Sunroof Switch Circuit Check 10

### 1. CHECK SUNROOF SWITCH OUTPUT SIGNAL

1. Turn ignition switch ON.
2. Check voltage between sunroof motor assembly connector and ground.

Con- nector	Terminals (Wire color)		Condition	Voltage (V) (Approx.)
	(+)	(-)		
R6	2 (G)	Ground	Slide switch SLIDE POSITION 2 SLIDE POSITION 3 SLIDE POSITION 4	0
			Other than above	Battery voltage

OK or NG

- OK >> Replace sunroof motor assembly.  
 NG >> GO TO 2.

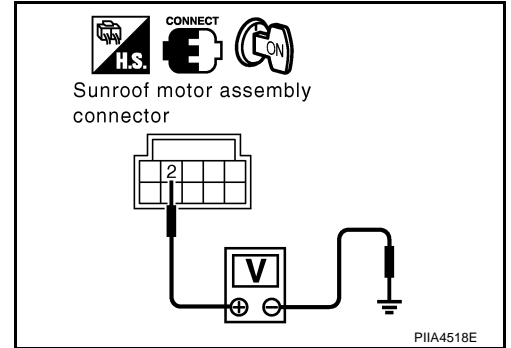

### 2. CHECK HARNESS CONTINUITY

1. Turn ignition switch OFF.
2. Disconnect sunroof motor assembly and sunroof switch connector.
3. Check continuity between sunroof motor assembly connector R6 terminal 2 and sunroof switch connector R5 terminal 1.

**2 (G) – 1 (G) : Continuity should exist.**

OK or NG

- OK >> GO TO 3.  
 NG >> Repair or replace harness between sunroof motor assembly and sunroof switch.

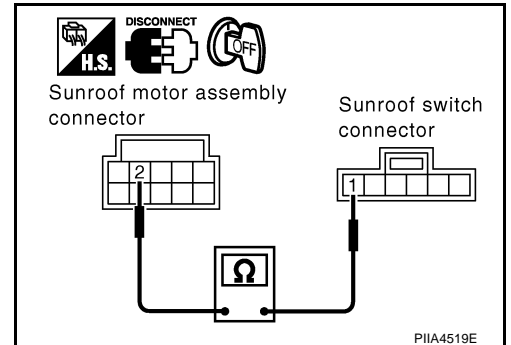

### 3. CHECK SUNROOF SWITCH

Check continuity between sunroof switch terminals 1 and 6.

Terminals		Condition	Continuity
1	6	Slide switch SLIDE POSITION 2 SLIDE POSITION 3 SLIDE POSITION 4	Yes
		Other than above	No

OK or NG

- OK >> Check the condition of the harness and the connector.  
 NG >> Replace sunroof switch.

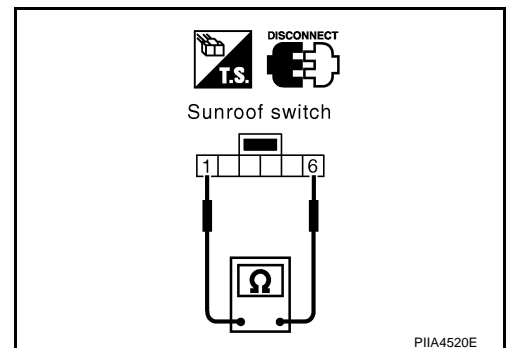

## Sunroof Switch Circuit Check 11

### 1. CHECK SUNROOF SWITCH OUTPUT SIGNAL

1. Turn ignition switch ON.
2. Check voltage between sunroof motor assembly connector and ground.

Con- nector	Terminals (Wire color)		Condition	Voltage (V) (Approx.)
	(+)	(-)		
R6	3 (R)	Ground	Slide switch FULL CLOSE SLIDE POSITION 1 SLIDE POSITION 2	0
			Other than above	Battery voltage

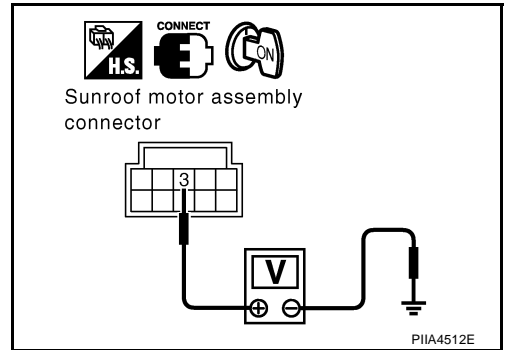

OK or NG

- OK >> Replace sunroof motor assembly.
- NG >> GO TO 2.

### 2. CHECK HARNESS CONTINUITY

1. Turn ignition switch OFF.
2. Disconnect sunroof motor assembly and sunroof switch connector.
3. Check continuity between sunroof motor assembly connector R6 terminal 3 and sunroof switch connector R5 terminal 2.

**3 (R) – 2 (R) : Continuity should exist.**

OK or NG

- OK >> GO TO 3.
- NG >> Repair or replace harness between sunroof motor assembly and sunroof switch.

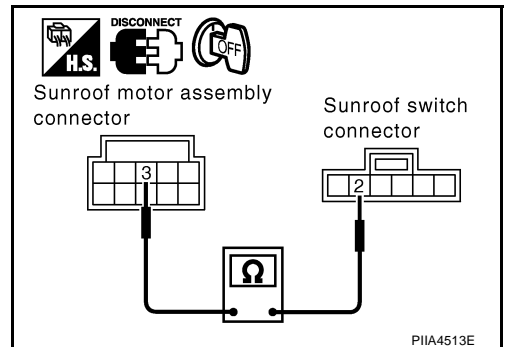

### 3. CHECK SUNROOF SWITCH

Check continuity between sunroof switch terminals 2 and 6.

Terminals		Condition	Continuity
2	6	Slide switch FULL CLOSE SLIDE POSITION 1 SLIDE POSITION 2	Yes
		Other than above	No

OK or NG

- OK >> Check the condition of the harness and the connector.
- NG >> Replace sunroof switch.

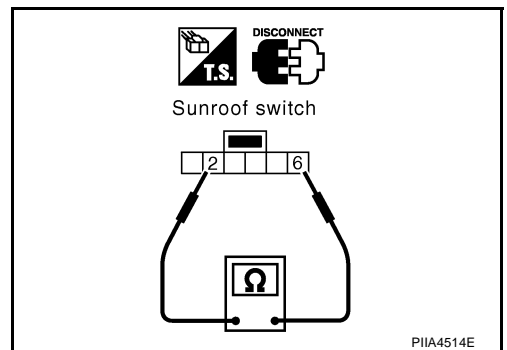



## Sunroof Switch Circuit Check 12

### 1. CHECK SUNROOF SWITCH OUTPUT SIGNAL

1. Turn ignition switch ON.
2. Check voltage between sunroof motor assembly connector and ground.

Con- nector	Terminals (Wire color)		Condition	Voltage (V) (Approx.)
	(+)	(-)		
R6	4 (Y)	Ground	Slide switch FULL CLOSE FULL OPEN SLIDE POSITION 4	0
			Other than above	Battery voltage

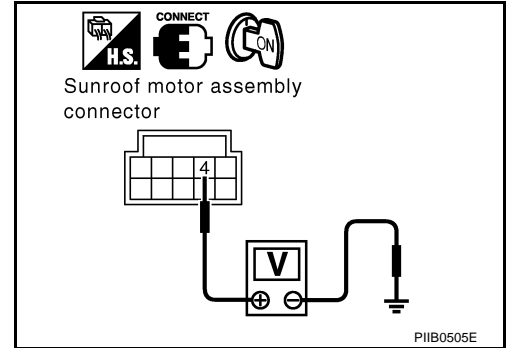

OK or NG

- OK >> Replace sunroof motor assembly.
- NG >> GO TO 2.

### 2. CHECK HARNESS CONTINUITY

1. Turn ignition switch OFF.
2. Disconnect sunroof motor assembly and sunroof switch connector.
3. Check continuity between sunroof motor assembly connector R6 terminal 4 and sunroof switch connector R5 terminal 3.

**4 (Y) – 3 (Y) : Continuity should exist.**

OK or NG

- OK >> GO TO 3.
- NG >> Repair or replace harness between sunroof motor assembly and sunroof switch.

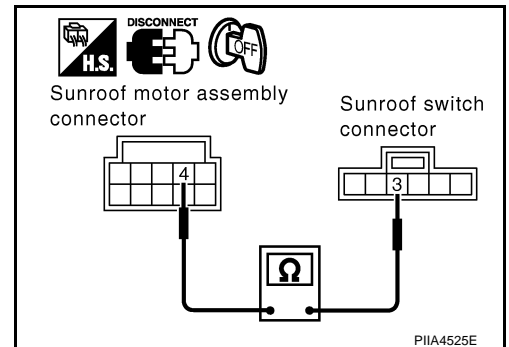

### 3. CHECK SUNROOF SWITCH

Check continuity between sunroof switch terminals 3 and 6.

Terminals		Condition	Continuity
3	6	Slide switch FULL CLOSE FULL OPEN SLIDE POSITION 4	Yes
		Other than above	No

OK or NG

- OK >> Check the condition of the harness and the connector.
- NG >> Replace sunroof switch.

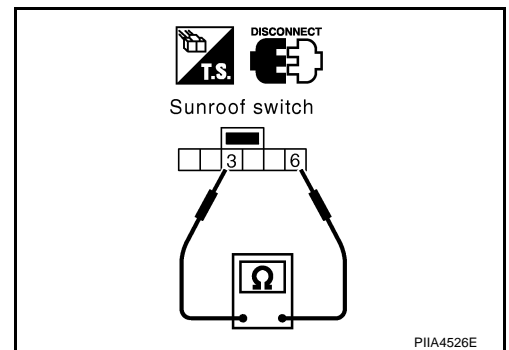

# SUNROOF

## Door Switch Check (With Intelligent Key)

AIIS002K1

### 1. CHECK DOOR SWITCH INPUT SIGNAL

#### ④ With CONSULT-II

Check door switches ("DOOR SW-DR" and "DOOR SW-AS") in "DATA MONITOR" mode with CONSULT-II.

Monitor item	Condition
DOOR SW-DR	OPEN : ON
	CLOSE : OFF
DOOR SW-AS	OPEN : ON
	CLOSE : OFF

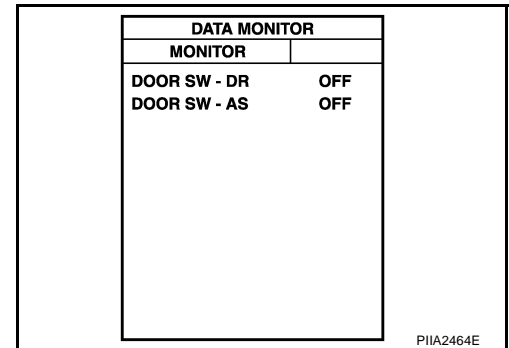

#### ⊗ Without CONSULT-II

Check voltage between BCM connector and ground.

Item	Con- nector	Terminals (Wire color)		Condition	Voltage (V) (Approx.)
		(+)	(-)		
Passenger side	M34	12 (R/G)	Ground	OPEN	0
				CLOSE	Battery voltage
Driver side	M36	62 (SB)	Ground	OPEN	0
				CLOSE	Battery voltage

#### OK or NG

- OK >> Door switch is OK.
- NG >> GO TO 2.

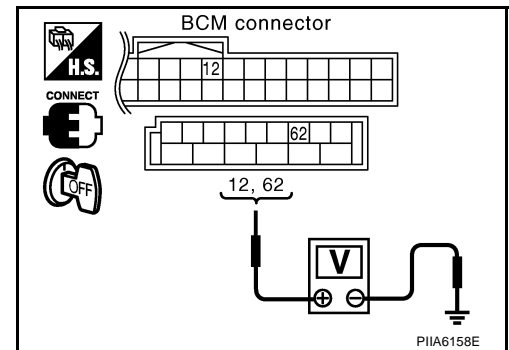

# SUNROOF

## 2. CHECK HARNESS CONTINUITY

1. Turn ignition switch OFF.
2. Disconnect BCM and front door lock assembly (driver side and passenger side) connector.
3. Check continuity between BCM connector M34, 36 terminals 12, 62 and front door lock assembly connector D10 (driver side), D38 (passenger side) terminal 4.

### Driver side

**62 (SB) – 4 (SB) : Continuity should exist.**

### Passenger side

**12 (R/G) – 4 (R/G) : Continuity should exist.**

4. Check continuity between BCM connector M34, 36 terminals 12, 62 and ground.

**12 (R/G) – Ground : Continuity should not exist.**

**62 (SB) – Ground : Continuity should not exist.**

### OK or NG

OK >> GO TO 3.

NG >> Repair or replace harness between BCM and front door lock assembly.

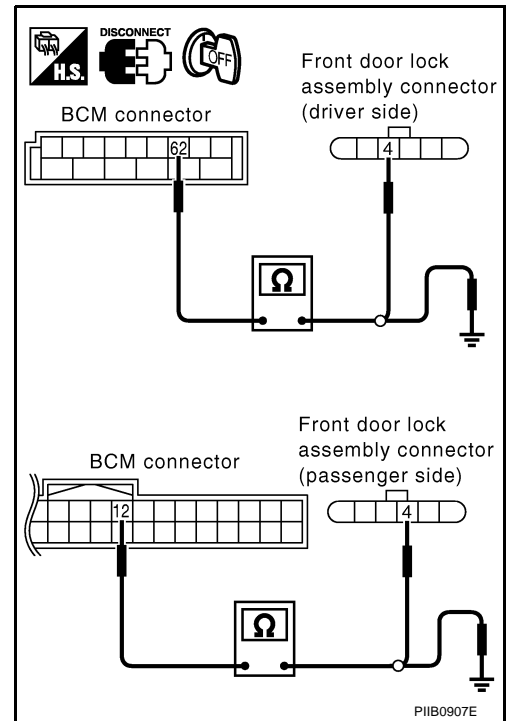

## 3. CHECK DOOR SWITCH

Check continuity between front door lock assembly terminal 4 and 5.

Terminal		Door switch	Continuity
4	5	OPEN	No
		CLOSE	Yes

### OK or NG

OK >> GO TO 4.

NG >> Replace malfunction front door lock assembly.

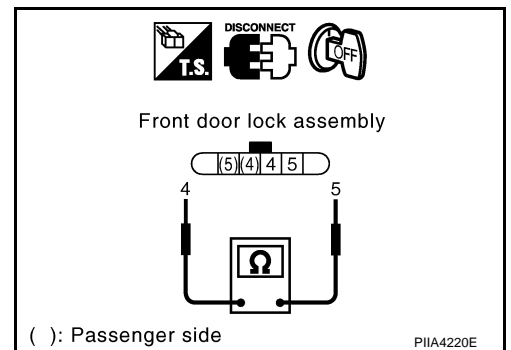

# SUNROOF

## 4. CHECK DOOR SWITCH GROUND CIRCUIT

1. Check continuity between front door lock assembly connector D10 (driver side), D38 (passenger side) terminal 5 and ground.

**5 (B) - Ground : Continuity should exist.**

OK or NG

- OK >> Check the condition of the harness and the connector.
- NG >> Repair or replace harness between front door lock assembly and ground.

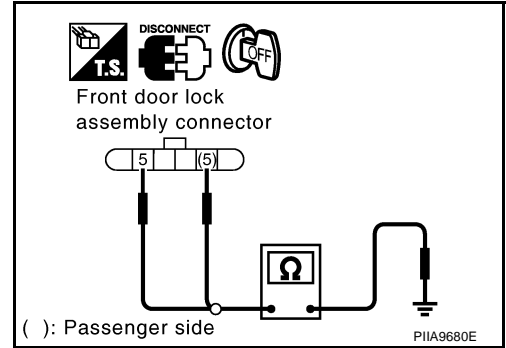

## Door Switch Check (Without Intelligent Key)

### 1. CHECK DOOR SWITCH INPUT SIGNAL

**With CONSULT-II**

Check door switches ("DOOR SW-DR" and "DOOR SW-AS") in "DATA MONITOR" mode with CONSULT-II.

Monitor item	Condition
DOOR SW-DR	OPEN : ON
	CLOSE : OFF
DOOR SW-AS	OPEN : ON
	CLOSE : OFF

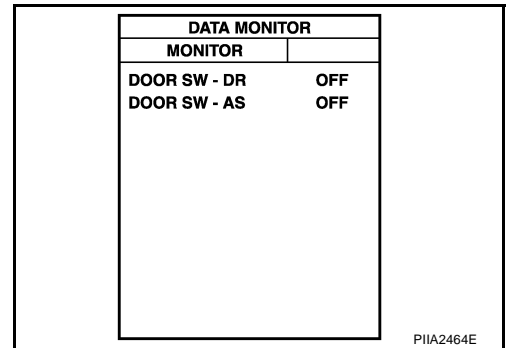

**Without CONSULT-II**

Check voltage between BCM connector and ground.

Item	Con- nector	Terminals (Wire color)		Condition	Voltage (V) (Approx.)
		(+)	(-)		
Passenger side	M34	12 (R)	Ground	OPEN	0
				CLOSE	Battery voltage
Driver side	M36	62 (SB)	Ground	OPEN	0
				CLOSE	Battery voltage

OK or NG

- OK >> Door switch is OK.
- NG >> GO TO 2.

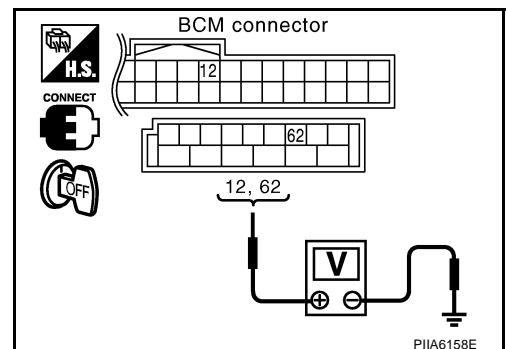

# SUNROOF

## 2. CHECK HARNESS CONTINUITY

1. Turn ignition switch OFF.
2. Disconnect BCM and front door lock assembly (driver side and passenger side) connector.
3. Check continuity between BCM connector M34, 36 terminals 12, 62 and front door lock assembly connector D10 (driver side), D38 (passenger side) terminal 4.

### Driver side

**62 (SB) – 4 (SB) : Continuity should exist.**

### Passenger side

**12 (R) – 4 (R/G) : Continuity should exist.**

4. Check continuity between BCM connector M34, 36 terminals 12, 62 and ground.

**12 (R) – Ground : Continuity should not exist.**

**62 (SB) – Ground : Continuity should not exist.**

### OK or NG

OK >> GO TO 3.

NG >> Repair or replace harness between BCM and front door lock assembly.

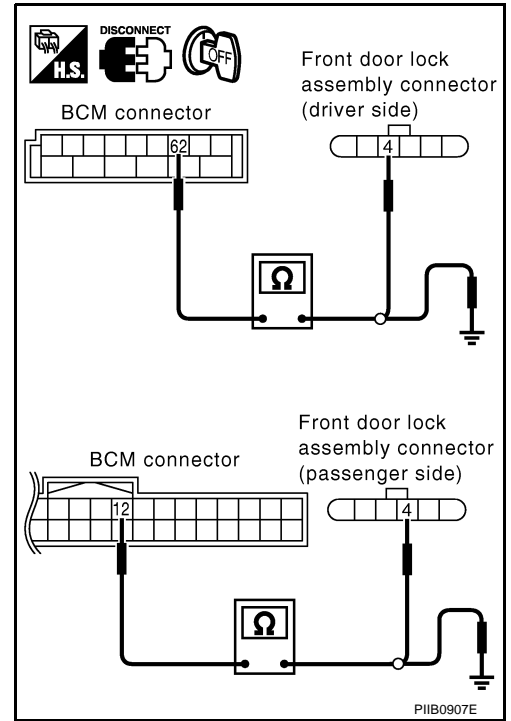

## 3. CHECK DOOR SWITCH

Check continuity between front door lock assembly terminal 4 and 5.

Terminal		Door switch	Continuity
4	5	OPEN	No
		CLOSE	Yes

### OK or NG

OK >> GO TO 4.

NG >> Replace malfunction front door lock assembly.

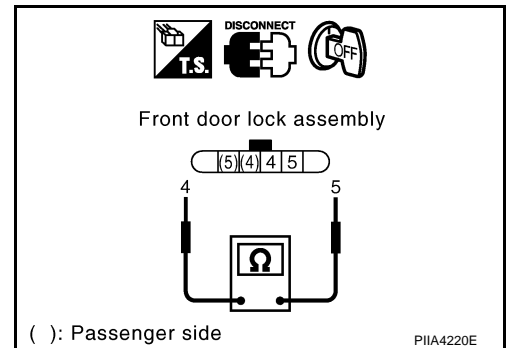

# SUNROOF

## 4. CHECK DOOR SWITCH GROUND CIRCUIT

1. Check continuity between front door lock assembly connector D10 (driver side), D38 (passenger side) terminal 5 and ground.

**5 (B) - Ground** : **Continuity should exist.**

OK or NG

- OK >> Check the condition of the harness and the connector.
- NG >> Repair or replace harness between front door lock assembly and ground.

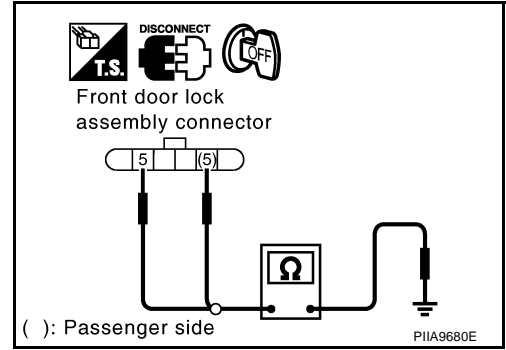

# SUNROOF

## Wind Deflector Inspection

AIS002E1

Check that the wind deflector is properly raised by manual. If a malfunction is detected, remove and visually check it. If it is damaged, replace it with a new one. If no damage is found, reinstall it properly.

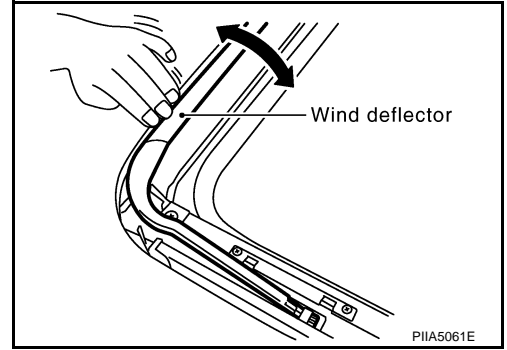

## Link and Wire Assembly

AIS002EJ

### NOTE:

Before replacing a suspect part, carefully ensure it is the source of noise being experienced.

1. Check link to determine if coated film has peeled off to such an extent that substrate is visible. Check also to determine if link is the source of noise. If it is, replace it.
2. Visually check to determine if a sufficient amount of grease has been applied to wire or rail groove. If not, add grease as required.
3. Check wire for any damage or deterioration. If any damage is found, replace wire.

## Fitting Adjustment

AIS002EK

	a	b	c
A - A	5.8 (0.228)	-0.8±1.5 (-0.031±0.059)	0.6 - 2.2 (0.024 - 0.087)
B - B	5.8 (0.228)	-0.8±1.5 (-0.031±0.059)	0.6 - 2.2 (0.024 - 0.087)
C - C	5.8 (0.228)	-0.8±1.5 (-0.031±0.059)	0.6 - 2.2 (0.024 - 0.087)

D - D (When sunroof is tilted up)

Unit: mm (in)

PIIA4248E

# SUNROOF

## LID WEATHERSTRIP OVERLAP ADJUSTMENT AND SURFACE MISMATCH ADJUSTMENT

1. Tilt up glass lid.
2. After loosening glass lid TORX bolts (T25) (left and right), tilt down glass lid.
3. Adjust glass lid from outside of vehicle so it resembles “A-A” “B-B” “C-C” as shown in the figure.
4. To prevent glass lid from moving after adjustment, first tighten the TORX bolts (T25) of front left, and then tighten the TORX bolts (T25) of rear right.
5. Tighten remaining TORX bolts (T25), being careful to prevent glass lid from moving.
6. Tilt glass lid up and down several times to check that it moves smoothly.

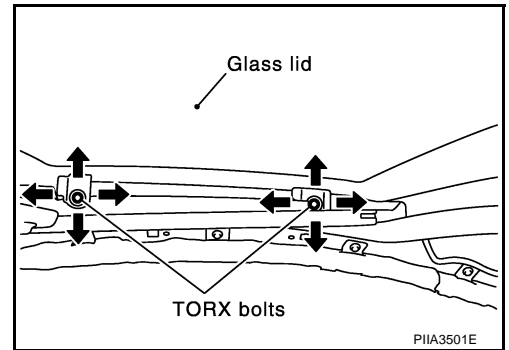

## Removal and Installation

- After any adjustment, check sunroof operation and glass lid alignment.
- Handle finisher plate and glass lid with care so not to cause damage.
- It is desirable for easy installation to mark each point before removal.

### CAUTION:

- Always work with a helper.
- Fully close the glass lid assembly, before removal, then do not operate sunroof motor assembly after removal.

AIS002EL



# SUNROOF

SEC. 736

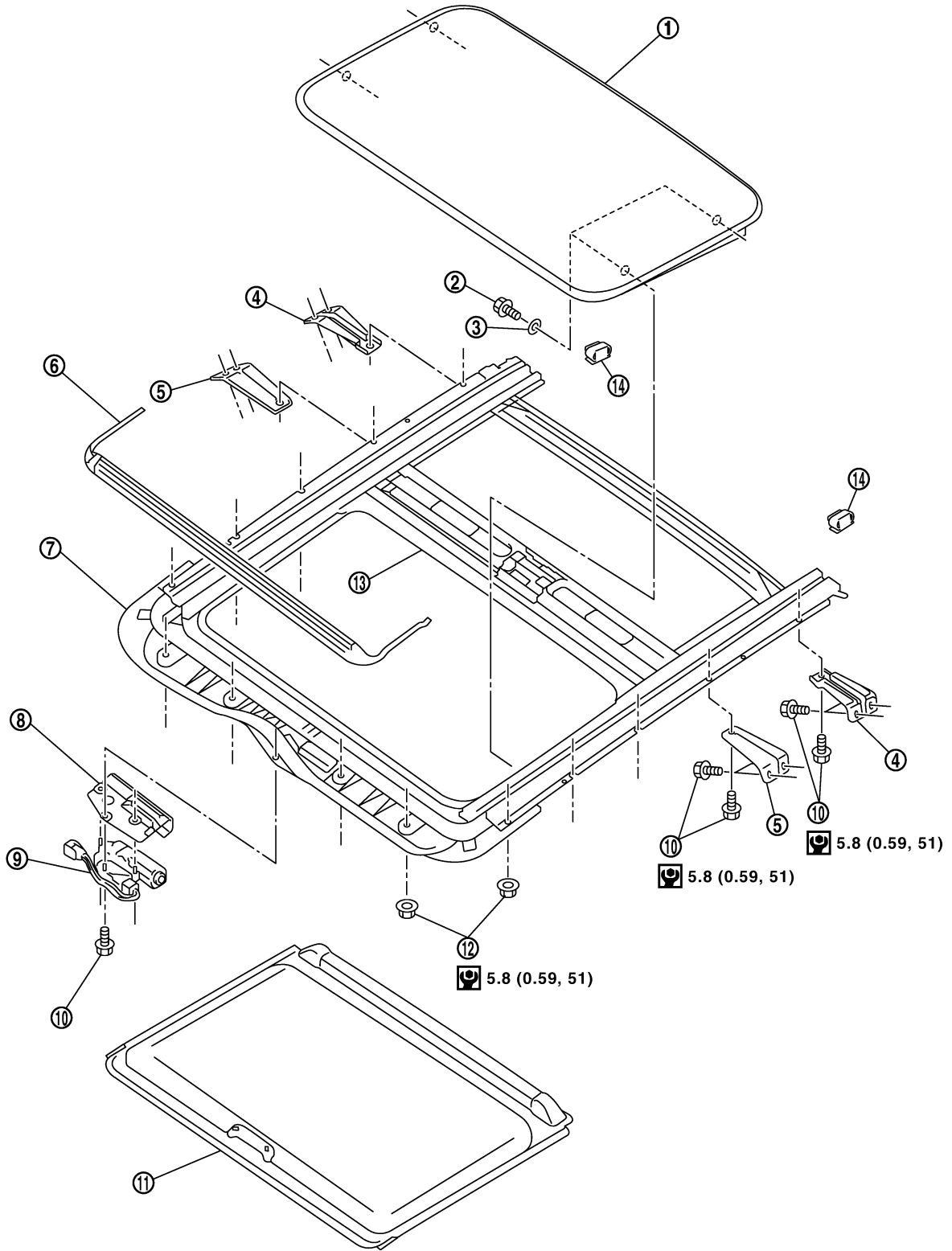

 : N·m (kg-m, in-lb)

A  
B  
C  
D  
E  
F  
G  
H  
RF  
J  
K  
L  
M

PIIB0906E

# SUNROOF

- |                          |                          |                           |
|--------------------------|--------------------------|---------------------------|
| 1. Glass lid             | 2. TORX bolt             | 3. Washer                 |
| 4. Rear sunroof bracket  | 5. Front sunroof bracket | 6. Wind deflector         |
| 7. Sunroof unit assembly | 8. Noise cover           | 9. Sunroof motor assembly |
| 10. Screw                | 11. Sunshade             | 12. Nut                   |
| 13. Drain plate          | 14. Sunshade stopper     |                           |

## SUNROOF UNIT ASSEMBLY

### Removal

#### CAUTION:

- Always work with a helper.
- When taking sunroof unit out, use shop clothes to protect the seats and trim from damage.
- After installing the sunroof unit and glass lid, be sure to perform the leakage test and make sure there is no malfunction.

1. Tilt glass lid up.
2. Remove the headlining. Refer to [EI-36, "Removal and Installation"](#).
3. Disconnect drain hoses.
4. Remove glass lid. Refer to [RF-43, "Removal"](#).
5. Remove motor mounting screws. Remove sunroof motor assembly and disconnect harness connector.

#### CAUTION:

- Before removing sunroof motor assembly, make sure that sunroof is fully closed.
- After removing sunroof motor assembly, do not attempt to rotate sunroof motor as a single unit.

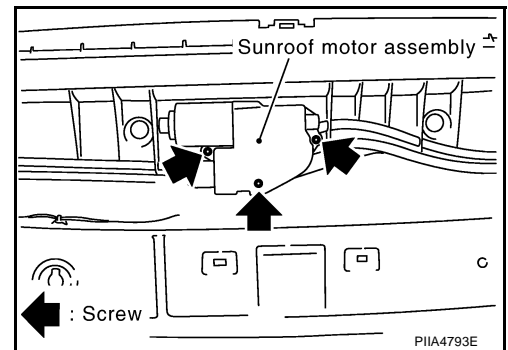

6. Remove nuts from the front end and side rail.

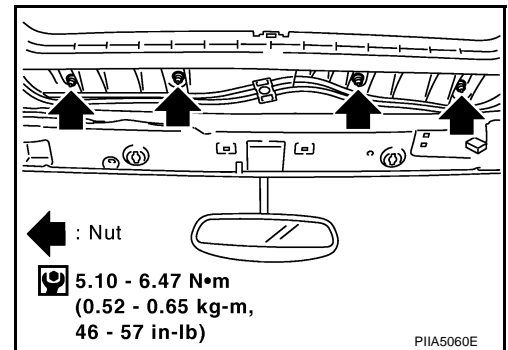

7. Remove sunroof bracket bolts, then remove sunroof unit assembly from roof panel.

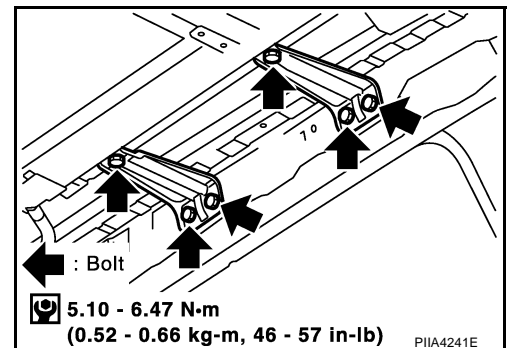

8. Remove sunroof unit assembly through the passenger compartment while being careful not to damage the seats and trim.

# SUNROOF

## Installation

1. Temporarily tighten the mounting bolts on the sunroof brackets (RH/LH).

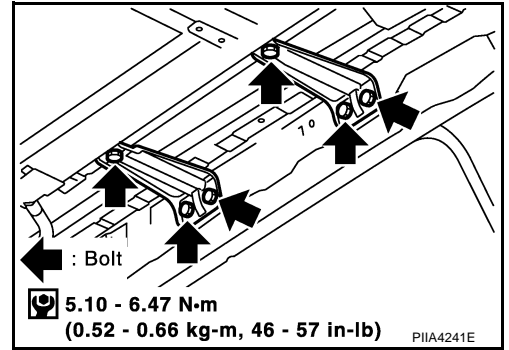

2. Bring sunroof unit assembly into passenger compartment and then place the rear end of the rail onto the sunroof brackets.
3. Tighten the mounting nuts on the front end.

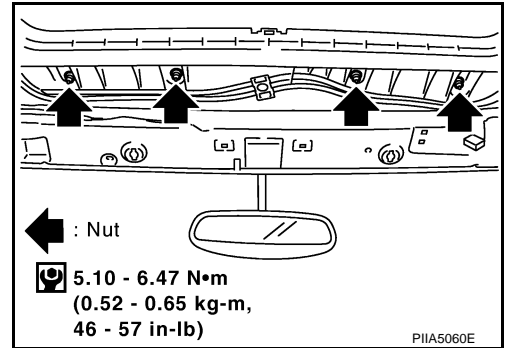

4. Tighten the installation points diagonally excluding the installation point of the sunroof bracket around the roof opening.
5. Tighten the rear sunroof bracket bolts of the vehicle side, and then tighten the bolt of the rail side.

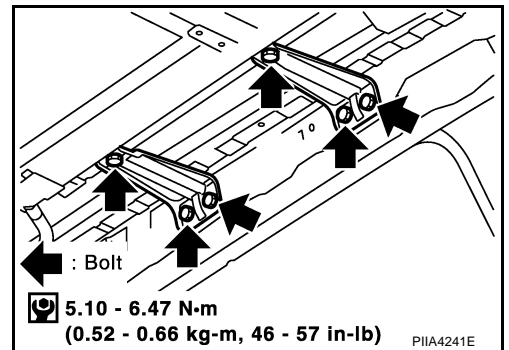

## GLASS LID

### Removal

1. Tilt up glass lid.
2. Remove TORX bolts (T25), then remove glass lid.

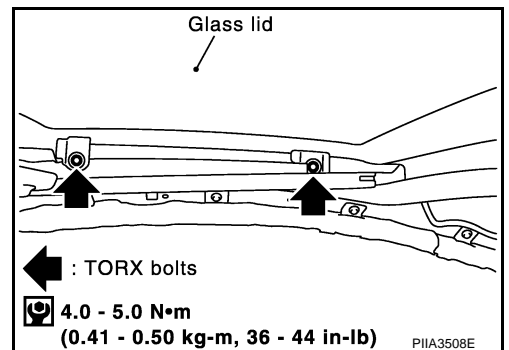

### Installation

1. Tighten bolts diagonally on the glass lid.
2. After installation, carry out fitting adjustment.

# SUNROOF

## SUNSHADE

### Removal

#### NOTE:

Detaching is possible even on the vehicle.

1. Remove the headlining. Refer to [EI-36, "Removal and Installation"](#).
2. Remove sunshade stopper.
3. Pull sunshade out of the rear end of the sunroof frame, and remove it from the frame.

#### CAUTION:

Thing working to damage neither sunshade and sunshade knob while lifting up a little.

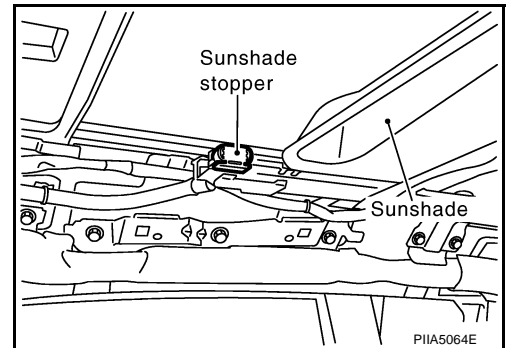

### Installation

Install in the reverse order of removal.

## WIND DEFLECTOR

### Removal

#### NOTE:

Detaching is possible even on the vehicle.

1. Open the sunroof lid.
2. Remove spring hinge screws, then remove hinge from the frame.
3. Remove stopper from the sunroof unit assembly.
4. Turn the wind deflector and then remove it from ditch of the sunroof unit assembly.

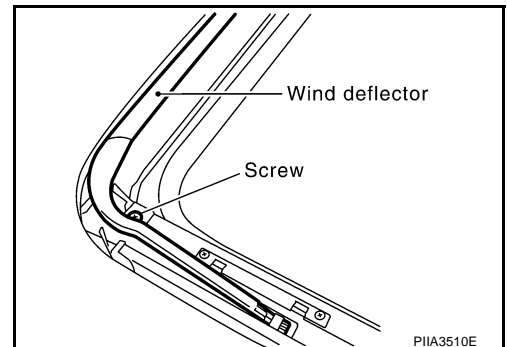

### Installation

Install in the reverse order of removal.

## SUNROOF MOTOR ASSEMBLY

### Removal

1. Remove headlining. Refer to [EI-36, "Removal and Installation"](#).
2. Remove sunroof motor mounting screws.
3. Disconnect harness connector from sunroof motor assembly, then remove sunroof motor assembly.

#### CAUTION:

- When removing the sunroof motor assembly, be sure that the sunroof lid is in the fully closed position.
- Do not run the removed sunroof motor assembly as a single unit.

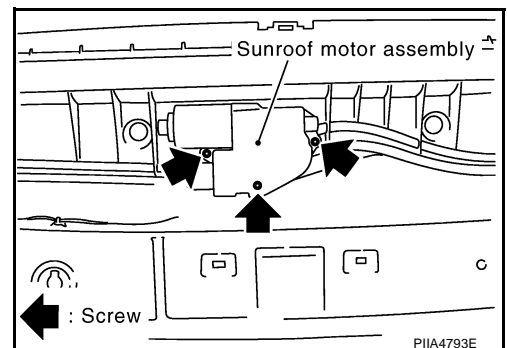

### Installation

1. Move the sunroof motor assembly laterally little by little so that the gear is completely engaged into the wire on the sunroof unit assembly and the mounting surface becomes parallel. Then secure the sunroof motor assembly with screws.

# SUNROOF

## CAUTION:

- Before installing the sunroof motor assembly, be sure to place the link and wire assembly in the symmetrical and fully closed position.
- Align the link notch with the hole of the culisse (fully closed : RH and LH).

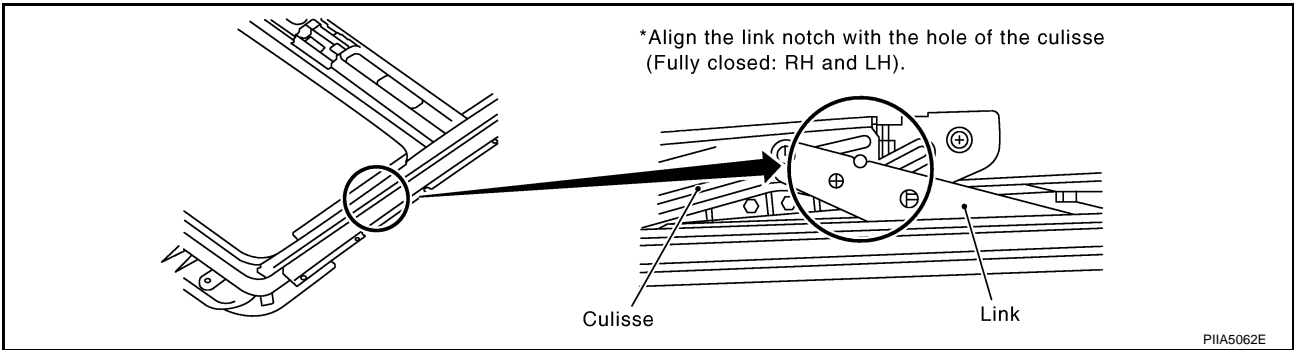

2. Confirm the body ground of the noise cover is connected.

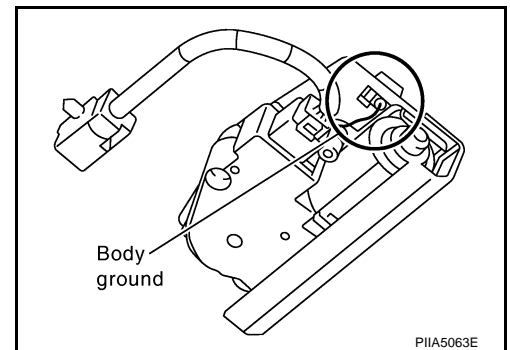

3. Initialization it after installing the sunroof motor. Refer to [RF-12, "INITIALIZATION PROCEDURE"](#) .

# SUNROOF

---