

SECTION **IP**
INSTRUMENT PANEL

A
B
C
D
E
F
G
H
IP
J
K
L
M

CONTENTS

PRECAUTIONS	2	DOORS	6
Precautions for Supplemental Restraint System (SRS) "AIR BAG" and "SEAT BELT PRE-TENSIONER"	2	TRUNK	7
Precautions	2	SUNROOF/HEADLINING	7
PREPARATION	3	SEATS	7
Special Service Tools	3	UNDERHOOD	7
Commercial Service Tools	3	Diagnostic Worksheet	8
SQUEAK AND RATTLE TROUBLE DIAGNOSES	4	INSTRUMENT PANEL ASSEMBLY	10
Work Flow	4	Component Parts Drawing	10
CUSTOMER INTERVIEW	4	Removal and Installation	11
DUPLICATE THE NOISE AND TEST DRIVE	5	WORK STEP	11
CHECK RELATED SERVICE BULLETINS	5	REMOVAL	12
LOCATE THE NOISE AND IDENTIFY THE ROOT CAUSE	5	INSTALLATION	15
REPAIR THE CAUSE	5	CENTER CONSOLE ASSEMBLY	17
CONFIRM THE REPAIR	6	Component Parts Drawing	17
Generic Squeak and Rattle Troubleshooting	6	Removal and Installation	18
INSTRUMENT PANEL	6	REMOVAL	18
CENTER CONSOLE	6	INSTALLATION	19
		Disassembly and Assembly	19
		CENTER CONSOLE	19

PRECAUTIONS

PRECAUTIONS

PFP:00001

Precautions for Supplemental Restraint System (SRS) “AIR BAG” and “SEAT BELT PRE-TENSIONER”

AIS002MA

The Supplemental Restraint System such as “AIR BAG” and “SEAT BELT PRE-TENSIONER”, used along with a front seat belt, helps to reduce the risk or severity of injury to the driver and front passenger for certain types of collision. This system includes seat belt switch inputs and dual stage front air bag modules. The SRS system uses the seat belt switches to determine the front air bag deployment, and may only deploy one front air bag, depending on the severity of a collision and whether the front occupants are belted or unbelted. Information necessary to service the system safely is included in the SRS and SB section of this Service Manual.

WARNING:

- **To avoid rendering the SRS inoperative, which could increase the risk of personal injury or death in the event of a collision which would result in air bag inflation, all maintenance must be performed by an authorized NISSAN/INFINITI dealer.**
- **Improper maintenance, including incorrect removal and installation of the SRS, can lead to personal injury caused by unintentional activation of the system. For removal of Spiral Cable and Air Bag Module, see the SRS section.**
- **Do not use electrical test equipment on any circuit related to the SRS unless instructed to in this Service Manual. SRS wiring harnesses can be identified by yellow and/or orange harnesses or harness connectors.**

Precautions

AIS002MC

- Disconnect both battery cables in advance.
- Disconnect air bag system line in advance.
- Never tamper with or force air bag lid open, as this may adversely affect air bag performance.
- Be careful not to scratch pad and other parts.
- When removing or disassembling any part, be careful not to damage or deform it. Protect parts, which may get in the way with cloth.
- When removing parts with a screwdriver or other tool, protect parts by wrapping them with vinyl or tape.
- Keep removed parts protected with cloth.
- If a clip is deformed or damaged, replace it.
- If an un reusable part is removed, replace it with a new one.
- Tighten bolts and nuts firmly to the specified torque.
- After re-assembly has been completed, make sure each part functions correctly.
- Remove stains in the following way.

Water-soluble stains:

Dip a soft cloth in warm water, and then squeeze it tightly. After wiping the stain, wipe with a soft dry cloth.

Oil stain:

Dissolve a synthetic detergent in warm water (density of 2 to 3% or less), dip the cloth, then clean off the stain with the cloth. Next, dip the cloth in fresh water and squeeze it tightly. Then clean off the detergent completely. Then wipe the area with a soft dry cloth.

- Do not use any organic solvent, such as thinner or benzene.

PREPARATION

PREPARATION

PFP:00002

Special Service Tools

AIS004VN

The actual shapes of Kent-Moore tools may differ from those of special service tools illustrated here.

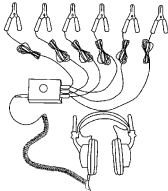
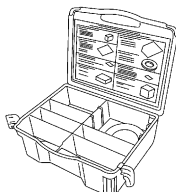
Tool number (Kent-Moore No.) Tool name	Description
(J-39570) Chassis ear  SIIA0993E	Locating the noise
(J-43980) NISSAN Squeak and Rattle Kit  SIIA0994E	Repairing the cause of noise

Commercial Service Tools

AIS004VO

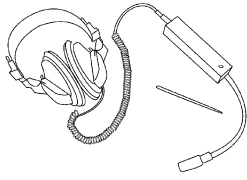
Tool name	Description
Engine ear  SIIA0995E	Locating the noise

SQUEAK AND RATTLE TROUBLE DIAGNOSES

SQUEAK AND RATTLE TROUBLE DIAGNOSES

PFP:00000

Work Flow

AIS004VP



CUSTOMER INTERVIEW

Interview the customer if possible, to determine the conditions that exist when the noise occurs. Use the Diagnostic Worksheet during the interview to document the facts and conditions when the noise occurs and any customer's comments; refer to [IP-8, "Diagnostic Worksheet"](#). This information is necessary to duplicate the conditions that exist when the noise occurs.

- The customer may not be able to provide a detailed description or the location of the noise. Attempt to obtain all the facts and conditions that exist when the noise occurs (or does not occur).
- If there is more than one noise in the vehicle, be sure to diagnose and repair the noise that the customer is concerned about. This can be accomplished by test driving the vehicle with the customer.
- After identifying the type of noise, isolate the noise in terms of its characteristics. The noise characteristics are provided so the customer, service adviser and technician are all speaking the same language when defining the noise.
- Squeak —(Like tennis shoes on a clean floor)
Squeak characteristics include the light contact/fast movement/brought on by road conditions/hard surfaces=higher pitch noise/softer surfaces=lower pitch noises/edge to surface=chirping
- Creak—(Like walking on an old wooden floor)
Creak characteristics include firm contact/slow movement/twisting with a rotational movement/pitch dependent on materials/often brought on by activity.
- Rattle—(Like shaking a baby rattle)
Rattle characteristics include the fast repeated contact/vibration or similar movement/loose parts/missing clip or fastener/incorrect clearance.
- Knock —(Like a knock on a door)
Knock characteristics include hollow sounding/sometimes repeating/often brought on by driver action.
- Tick—(Like a clock second hand)
Tick characteristics include gentle contacting of light materials/loose components/can be caused by driver action or road conditions.
- Thump—(Heavy, muffled knock noise)
Thump characteristics include softer knock/dead sound often brought on by activity.
- Buzz—(Like a bumble bee)
Buzz characteristics include high frequency rattle/firm contact.
- Often the degree of acceptable noise level will vary depending upon the person. A noise that you may judge as acceptable may be very irritating to the customer.
- Weather conditions, especially humidity and temperature, may have a great effect on noise level.

SQUEAK AND RATTLE TROUBLE DIAGNOSES

DUPLICATE THE NOISE AND TEST DRIVE

If possible, drive the vehicle with the customer until the noise is duplicated. Note any additional information on the Diagnostic Worksheet regarding the conditions or location of the noise. This information can be used to duplicate the same conditions when you confirm the repair.

If the noise can be duplicated easily during the test drive, to help identify the source of the noise, try to duplicate the noise with the vehicle stopped by doing one or all of the following:

- 1) Close a door.
 - 2) Tap or push/pull around the area where the noise appears to be coming from.
 - 3) Rev the engine.
 - 4) Use a floor jack to recreate vehicle "twist".
 - 5) At idle, apply engine load (electrical load, half-clutch on M/T model, drive position on A/T model).
 - 6) Raise the vehicle on a hoist and hit a tire with a rubber hammer.
- Drive the vehicle and attempt to duplicate the conditions the customer states exist when the noise occurs.
 - If it is difficult to duplicate the noise, drive the vehicle slowly on an undulating or rough road to stress the vehicle body.

CHECK RELATED SERVICE BULLETINS

After verifying the customer concern or symptom, check ASIST for Technical Service Bulletins (TSBs) related to that concern or symptom.

If a TSB relates to the symptom, follow the procedure to repair the noise.

LOCATE THE NOISE AND IDENTIFY THE ROOT CAUSE

1. Narrow down the noise to a general area. To help pinpoint the source of the noise, use a listening tool (Chassis Ear: J-39570, Engine Ear and mechanics stethoscope).
2. Narrow down the noise to a more specific area and identify the cause of the noise by:
 - removing the components in the area that you suspect the noise is coming from.
Do not use too much force when removing clips and fasteners, otherwise clips and fastener can be broken or lost during the repair, resulting in the creation of new noise.
 - tapping or pushing/pulling the component that you suspect is causing the noise.
Do not tap or push/pull the component with excessive force, otherwise the noise will be eliminated only temporarily.
 - feeling for a vibration with your hand by touching the component(s) that you suspect is (are) causing the noise.
 - placing a piece of paper between components that you suspect are causing the noise.
 - looking for loose components and contact marks.
Refer to [IP-6, "Generic Squeak and Rattle Troubleshooting"](#) .

REPAIR THE CAUSE

- If the cause is a loose component, tighten the component securely.
- If the cause is insufficient clearance between components:
 - separate components by repositioning or loosening and retightening the component, if possible.
 - insulate components with a suitable insulator such as urethane pads, foam blocks, felt cloth tape or urethane tape. A NISSAN Squeak and Rattle Kit (J-43980) is available through your authorized NISSAN Parts Department.

CAUTION:

Do not use excessive force as many components are constructed of plastic and may be damaged.

Always check with the Parts Department for the latest parts information.

The following materials are contained in the NISSAN Squeak and Rattle Kit (J-43980). Each item can be ordered separately as needed.

URETHANE PADS [1.5 mm (0.059 in) thick]

Insulates connectors, harness, etc.

76268-9E005: 100 × 135 mm (3.94 × 5.31 in)/76884-71L01: 60 × 85 mm (2.36 × 3.35 in)/76884-71L02: 15 × 25 mm (0.59 × 0.98 in)

INSULATOR (Foam blocks)

Insulates components from contact. Can be used to fill space behind a panel.

73982-9E000: 45 mm (1.77 in) thick, 50 × 50 mm (1.97 × 1.97 in)/73982-50Y00: 10 mm (0.39 in) thick, 50 × 50 mm (1.97 × 1.97 in)

SQUEAK AND RATTLE TROUBLE DIAGNOSES

INSULATOR (Light foam block)

80845-71L00: 30 mm (1.18 in) thick, 30 × 50 mm (1.18 × 1.97 in)

FELT CLOTH TAPE

Used to insulate where movement does not occur. Ideal for instrument panel applications.

68370-4B000: 15 × 25 mm (0.59 × 0.98 in) pad/68239-13E00: 5 mm (0.20 in) wide tape roll

The following materials, not found in the kit, can also be used to repair squeaks and rattles.

UHMW (TEFLON) TAPE

Insulates where slight movement is present. Ideal for instrument panel applications.

SILICONE GREASE

Used in place of UHMW tape that will be visible or not fit.

Note: Will only last a few months.

SILICONE SPRAY

Use when grease cannot be applied.

DUCT TAPE

Use to eliminate movement.

CONFIRM THE REPAIR

Confirm that the cause of a noise is repaired by test driving the vehicle. Operate the vehicle under the same conditions as when the noise originally occurred. Refer to the notes on the Diagnostic Worksheet.

Generic Squeak and Rattle Troubleshooting

AIS004VQ

Refer to Table of Contents for specific component removal and installation information.

INSTRUMENT PANEL

Most incidents are caused by contact and movement between:

1. The cluster lid A and instrument panel
2. Acrylic lens and combination meter housing
3. Instrument panel to front pillar garnish
4. Instrument panel to windshield
5. Instrument panel mounting pins
6. Wiring harnesses behind the combination meter
7. A/C defroster duct and duct joint

These incidents can usually be located by tapping or moving the components to duplicate the noise or by pressing on the components while driving to stop the noise. Most of these incidents can be repaired by applying felt cloth tape or silicon spray (in hard to reach areas). Urethane pads can be used to insulate wiring harness.

CAUTION:

Do not use silicone spray to isolate a squeak or rattle. If you saturate the area with silicone, you will not be able to recheck the repair.

CENTER CONSOLE

Components to pay attention to include:

1. Shifter assembly cover to finisher
2. A/C control unit and cluster lid C
3. Wiring harnesses behind audio and A/C control unit

The instrument panel repair and isolation procedures also apply to the center console.

DOORS

Pay attention to the:

1. Finisher and inner panel making a slapping noise
2. Inside handle escutcheon to door finisher
3. Wiring harnesses tapping
4. Door striker out of alignment causing a popping noise on starts and stops

Tapping or moving the components or pressing on them while driving to duplicate the conditions can isolate many of these incidents. You can usually insulate the areas with felt cloth tape or insulator foam blocks from the NISSAN Squeak and Rattle Kit (J-43980) to repair the noise.

SQUEAK AND RATTLE TROUBLE DIAGNOSES

TRUNK

Trunk noises are often caused by a loose jack or loose items put into the trunk by the owner. In addition look for:

1. Trunk lid dumpers out of adjustment
2. Trunk lid striker out of adjustment
3. The trunk lid torsion bars knocking together
4. A loose license plate or bracket

Most of these incidents can be repaired by adjusting, securing or insulating the item(s) or component(s) causing the noise.

SUNROOF/HEADLINING

Noises in the sunroof/headlining area can often be traced to one of the following:

1. Sunroof lid, rail, linkage or seals making a rattle or light knocking noise
2. Sunvisor shaft shaking in the holder
3. Front or rear windshield touching headlining and squeaking

Again, pressing on the components to stop the noise while duplicating the conditions can isolate most of these incidents. Repairs usually consist of insulating with felt cloth tape.

SEATS

When isolating seat noise it's important to note the position the seat is in and the load placed on the seat when the noise is present. These conditions should be duplicated when verifying and isolating the cause of the noise.

Cause of seat noise include:

1. Headrest rods and holder
2. A squeak between the seat pad cushion and frame
3. The rear seatback lock and bracket

These noises can be isolated by moving or pressing on the suspected components while duplicating the conditions under which the noise occurs. Most of these incidents can be repaired by repositioning the component or applying urethane tape to the contact area.

UNDERHOOD

Some interior noise may be caused by components under the hood or on the engine wall. The noise is then transmitted into the passenger compartment.

Causes of transmitted underhood noise include:

1. Any component mounted to the engine wall
2. Components that pass through the engine wall
3. Engine wall mounts and connectors
4. Loose radiator mounting pins
5. Hood bumpers out of adjustment
6. Hood striker out of adjustment

These noises can be difficult to isolate since they cannot be reached from the interior of the vehicle. The best method is to secure, move or insulate one component at a time and test drive the vehicle. Also, engine RPM or load can be changed to isolate the noise. Repairs can usually be made by moving, adjusting, securing, or insulating the component causing the noise.

A

B

C

D

E

F

G

H

IP

J

K

L

M

SQUEAK AND RATTLE TROUBLE DIAGNOSES

Diagnostic Worksheet

AI5004VR

SQUEAK & RATTLE DIAGNOSTIC WORKSHEET

Dear Nissan Customer:

We are concerned about your satisfaction with your Nissan vehicle. Repairing a squeak or rattle sometimes can be very difficult. To help us fix your Nissan right the first time, please take a moment to note the area of the vehicle where the squeak or rattle occurs and under what conditions. You may be asked to take a test drive with a service advisor or technician to ensure we confirm the noise you are hearing.

I. WHERE DOES THE NOISE COME FROM? (circle the area of the vehicle)

The illustrations are for reference only, and may not reflect the actual configuration of your vehicle.

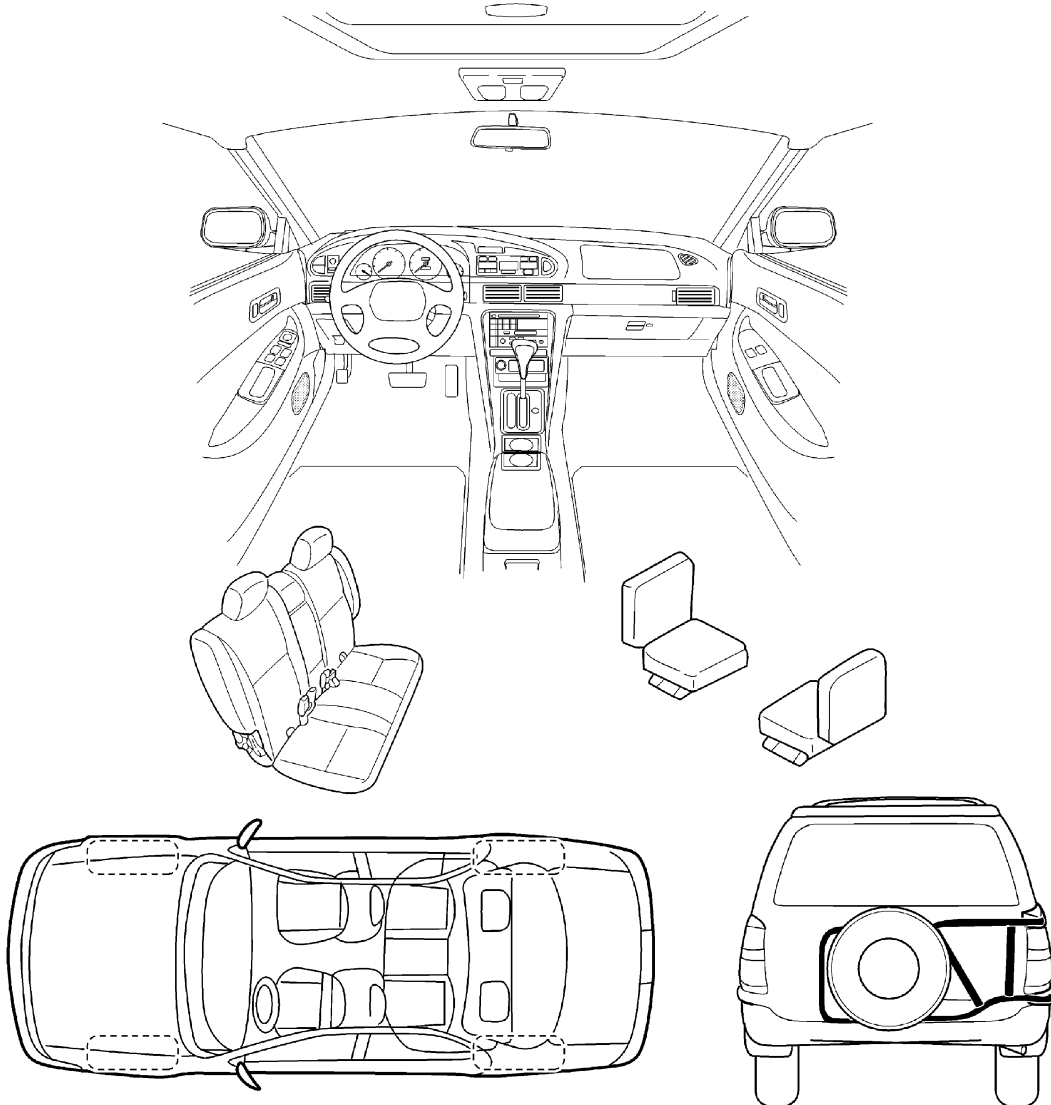

Continue to the back of the worksheet and briefly describe the location of the noise or rattle. In addition, please indicate the conditions which are present when the noise occurs.

PIIB0723E

SQUEAK AND RATTLE TROUBLE DIAGNOSES

SQUEAK & RATTLE DIAGNOSTIC WORKSHEET- page 2

Briefly describe the location where the noise occurs:

II. WHEN DOES IT OCCUR? (check the boxes that apply)

- | | |
|--|---|
| <input type="checkbox"/> anytime | <input type="checkbox"/> after sitting out in the sun |
| <input type="checkbox"/> 1 st time in the morning | <input type="checkbox"/> when it is raining or wet |
| <input type="checkbox"/> only when it is cold outside | <input type="checkbox"/> dry or dusty conditions |
| <input type="checkbox"/> only when it is hot outside | <input type="checkbox"/> other: _____ |

III. WHEN DRIVING:

- through driveways
- over rough roads
- over speed bumps
- only at about ____ mph
- on acceleration
- coming to a stop
- on turns : left, right or either (circle)
- with passengers or cargo
- other: _____
- after driving ____ miles or ____ minutes

IV. WHAT TYPE OF NOISE?

- squeak (like tennis shoes on a clean floor)
- creak (like walking on an old wooden floor)
- rattle (like shaking a baby rattle)
- knock (like a knock on a door)
- tick (like a clock second hand)
- thump (heavy, muffled knock noise)
- buzz (like a bumble bee)

TO BE COMPLETED BY DEALERSHIP PERSONNEL

Test Drive Notes:

	YES	NO	Initials of person performing
Vehicle test driven with customer	<input type="checkbox"/>	<input type="checkbox"/>	_____
- Noise verified on test drive	<input type="checkbox"/>	<input type="checkbox"/>	_____
- Noise source located and repaired	<input type="checkbox"/>	<input type="checkbox"/>	_____
- Follow up test drive performed to confirm repair	<input type="checkbox"/>	<input type="checkbox"/>	_____

VIN: _____ Customer Name: _____

W.O. #: _____ Date: _____

This form must be attached to Work Order

SBT844

INSTRUMENT PANEL ASSEMBLY

PFP:68200

AIS002GC

INSTRUMENT PANEL ASSEMBLY

Component Parts Drawing

SEC. 248•280•487•680•969

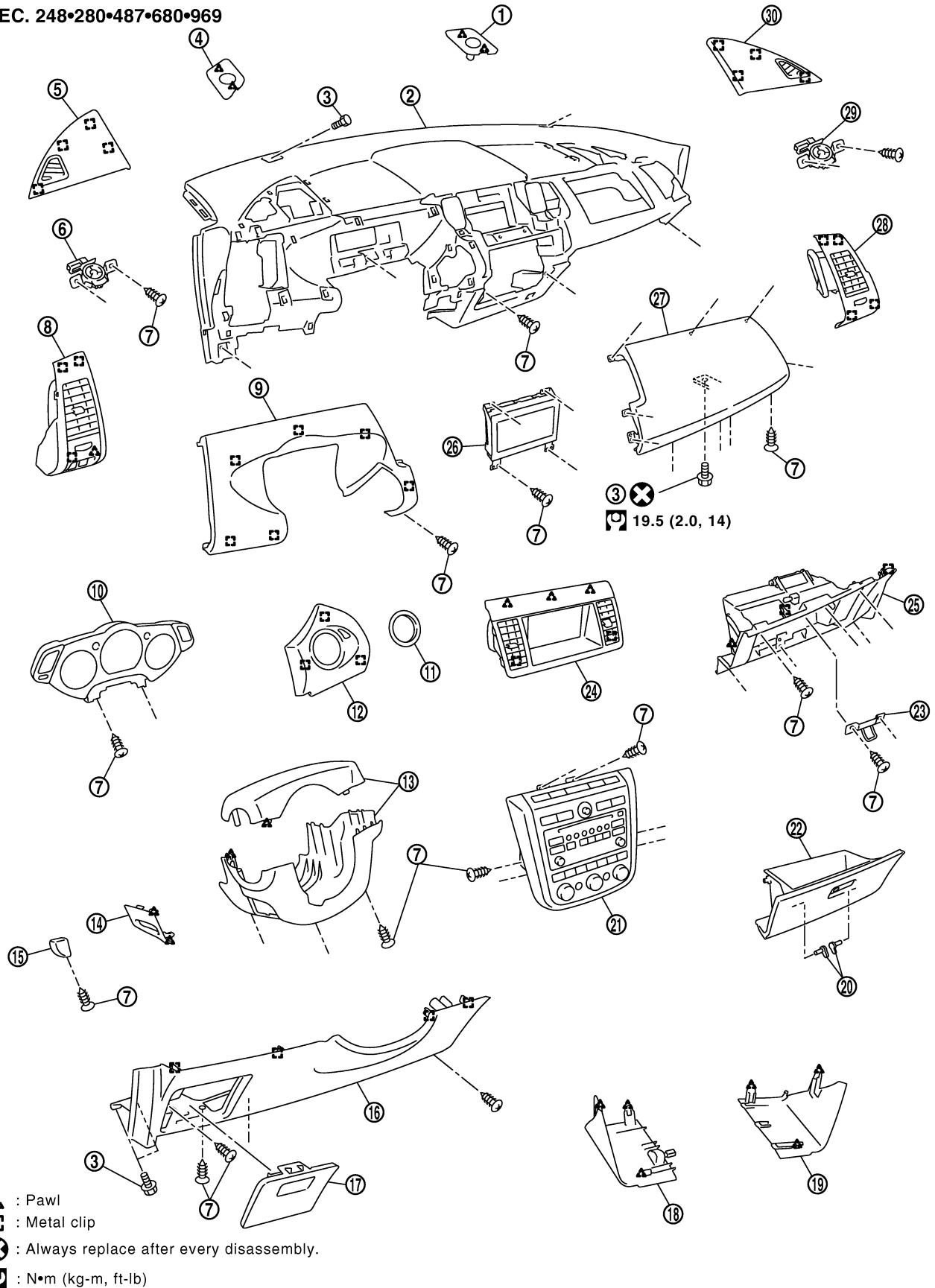

INSTRUMENT PANEL ASSEMBLY

1. Instrument mask (RH; Sunload sensor)	2. Instrument panel	3. Bolt
4. Instrument mask (LH; Auto light sensor)	5. Instrument side finisher (LH)	6. Tweeter (LH)
7. Screw	8. Side ventilator assembly (LH)	9. Instrument driver upper panel
10. Combination meter	11. Steering lock escutcheon	12. Ignition key finisher
13. Steering column cover	14. Tilt lever mask	15. Tilt lever knob
16. Instrument driver lower panel	17. Fuse lid	18. Instrument stay cover (LH)
19. Instrument stay cover (RH)	20. Glove box pin	21. Cluster lid C
22. Glove box assembly	23. Glove box striker	24. Center ventilator
25. Instrument passenger lower panel	26. Display	27. Instrument passenger upper panel
28. Side ventilator assembly (RH)	29. Tweeter (RH)	30. Instrument side finisher (RH)

Removal and Installation WORK STEP

AIS002GD

When removing instrument panel, combination meter, A/C and AV switch, display unit, take steps in the order shown by the numbers below.

CAUTION:

- **Disconnect both battery cables in advance.**
- **Disconnect air bag system line in advance.**
- **Never tamper with or force air bag lid open, as this may adversely affect air bag performance.**
- **Be careful not to scratch pad and other parts.**

	Parts	Reference page	Instrument panel and pad	Combination meter	A/C and AV switch panel	Display unit
A	Front kicking plate (LH/RH)	EI-33	(1)	(1)		
B	Fuse lid	IP-12	(2)	(2)		
C	Instrument driver lower panel	IP-12	(3)	(3)		
D	Tilt lever knob	IP-12	(4)	(4)		
E	Tilt lever mask	IP-12	(5)	(5)		
F	Steering column cover	IP-12	(6)	(6)		
G	Combination meter	IP-13	(7)	(7)		
H	Side ventilator assembly (LH/RH)	IP-13	(8)			
I	Instrument side finisher (LH/RH)	IP-13	(9)			
J	Instrument passenger lower panel assembly	IP-13	(10)			
K	Center ventilator	IP-14	(11)		(1)	(1)
L	Tweeter (LH/RH)	AV-71	(12)			
M	Instrument stay cover (LH/RH)	IP-14	(13)		(2)	
N	Cluster lid C	IP-14	(14)		(3)	
O	Display unit	AV-219	(15)			(2)
P	Ignition key finisher	IP-14	(16)			
Q	Instrument mask (LH)/ Optical sensor	IP-15	(17)			
R	Instrument mask (RH)/ Sunload sensor	IP-15	(18)			
S	Instrument driver upper panel	IP-15	(19)			
T	Instrument passenger upper panel	IP-15	(20)			
U	Front pillar garnish (LH/RH)	EI-33	(21)			
V	Instrument panel	IP-15	(22)			

(): Number indicates step in removal procedures.

INSTRUMENT PANEL ASSEMBLY

REMOVAL

(A) Front Kicking Plate (LH/RH)

Remove front kicking plate (LH/RH). Refer to [EI-32, "BODY SIDE TRIM"](#) .

(B) Fuse Lid

Remove fuse lid.

(C) Instrument Driver Lower Panel

1. Remove screws.
2. Remove data link connector.
3. Pull to disengage metal clips by removing panel in horizontal direction.
4. Disconnect in-vehicle sensor and each electrical parts.
5. Remove bolts, and remove hood lock opener.

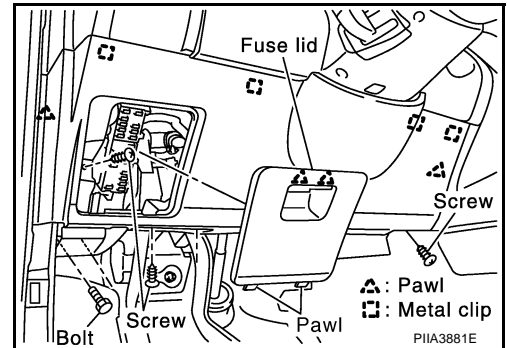

(D) Tilt Lever Knob

1. Remove screws.
2. Remove the knob by picking it up and pulling it out.

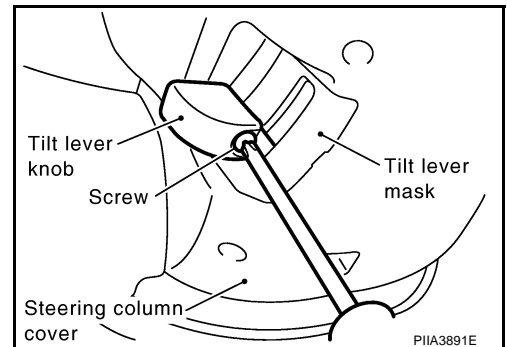

(E) Tilt Lever Mask

Using a remover, pry and remove tilt lever mask.

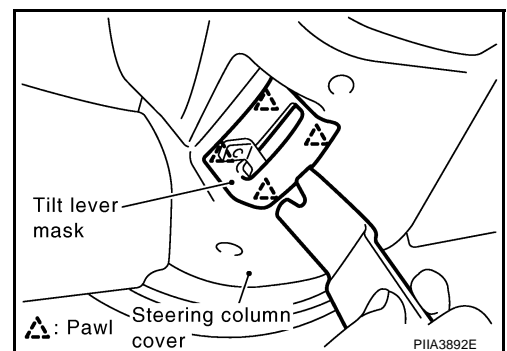

(F) Steering Column Cover

1. Remove screws.
2. Disengage the pawl, and remove steering column cover.

INSTRUMENT PANEL ASSEMBLY

(G) Combination Meter

After removing screws, remove harness connector.

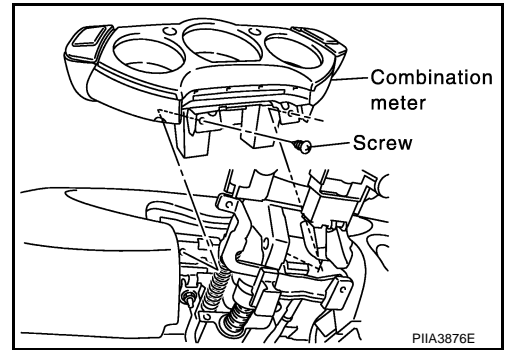

(H) Side Ventilator Assembly (LH/RH)

1. Using a remover, pry and remove side ventilator assembly (LH/RH).
2. Disconnect aiming switch harness connector and VDC switch harness connector only LH side.

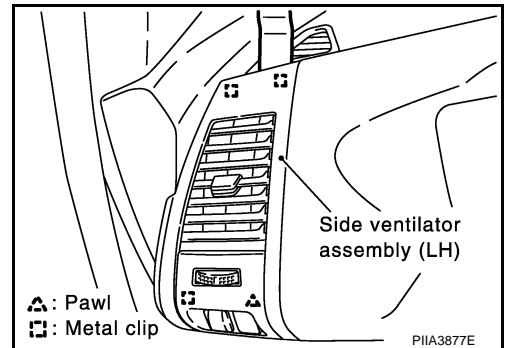

(I) Instrument Side Finisher (LH/RH)

Insert a remover into lower space of instrument side finisher (LH/RH) and remove by lifting.

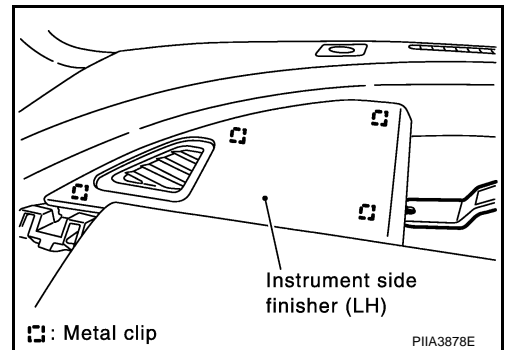

(J) Instrument Passenger Lower Panel Assembly

1. Remove screws and glove box striker, disconnect connectors, and remove instrument passenger lower panel assembly.

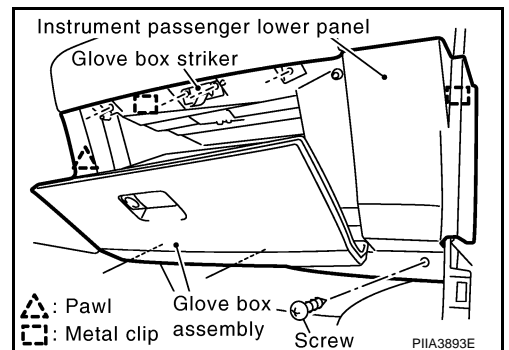

A
B
C
D
E
F
G
H

IP

J
K
L
M

INSTRUMENT PANEL ASSEMBLY

2. Detach the damper from glove box right side.
3. Remove glove box pins, and remove glove box.

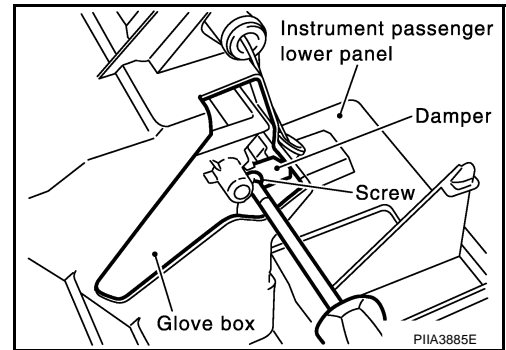

(K) Center Ventilator

1. Insert a remover into lower space of center ventilator and remove by lifting.
2. Insert a remover into upper space of center ventilator and the upper clip is removed.

CAUTION:

When a central bench is detached alone, past the protection tape to meter right side part.

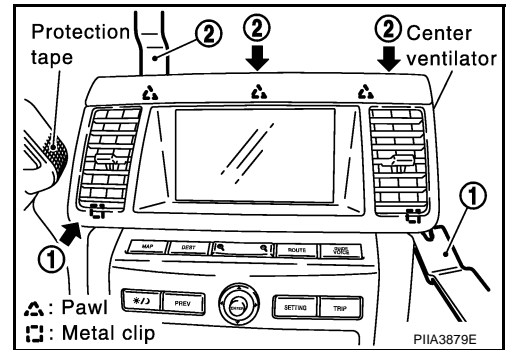

(L) Tweeter (LH/RH)

1. Remove screws.
2. Disconnect harness connector, and remove tweeter with RH and LH part. Refer to [AV-71, "Removal and Installation of Tweeter"](#) in AV section.

(M) Instrument Stay Cover (LH/RH)

1. Insert a remover into front space of instrument stay cover (LH/RH) and detach.
2. Disconnect the LH side harness connector only.

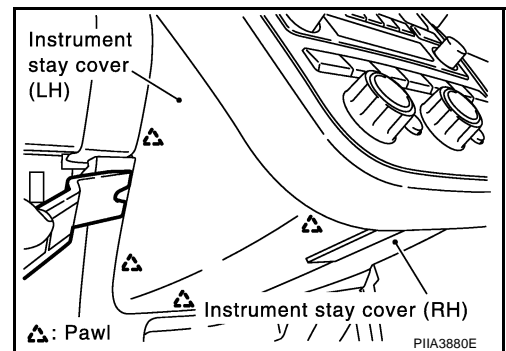

(N) Cluster Lid C

1. Remove screws.
2. Disconnect A/C and AV harness connectors, and remove cluster lid C.

CAUTION:

Unit is heavy, so be careful not to pinch your fingers when working.

(O) Display Unit

1. Remove screws.
2. Disconnect harness connector and remove display unit. Refer to [AV-103, "Removal and Installation of Display Unit"](#).

(P) Ignition Key Finisher

1. Using a remover and disengage the metal clips.
2. Disconnect harness connector.

INSTRUMENT PANEL ASSEMBLY

(Q) Instrument Mask (LH) / Optical Sensor

1. Using a remover, pry and remove instrument mask (LH).
2. Disconnect optical sensor harness connector. Refer to [LT-106, "Removal and Installation of Optical Sensor"](#) .

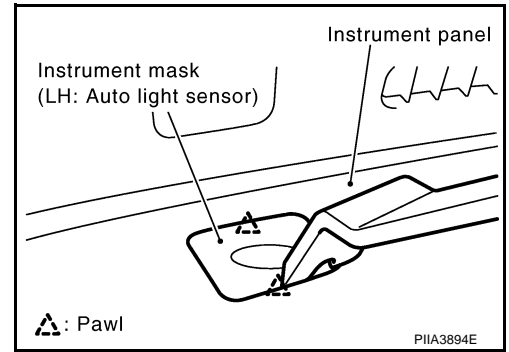

(R) Instrument Mask (RH) / Sunload Sensor

1. Using a remover, pry and remove instrument mask (RH).
2. Disconnect sunload sensor harness connector. Refer to [ATC-112, "SUNLOAD SENSOR"](#) .

(S) Instrument Driver Upper Panel

1. Remove screw.
2. Disengage the metal clip and remove instrument driver upper panel.

(T) Instrument Passenger Upper Panel

1. Remove bolt and screws.
2. Remove front passenger air bag module. Refer to [SRS-40, "FRONT PASSENGER AIR BAG MODULE"](#) .
3. Disconnect metal clips, then remove instrument passenger upper panel.
4. Disconnect harness connector.

(U) Front Pillar Garnish (LH/RH)

Pull to inside of vehicle, disconnect metal clips and remove front pillar garnish. Refer to [EI-33, "FRONT PILLAR GARNISH"](#) .

(V) Instrument Panel

1. Remove bolts and screws, and remove instrument panel from passenger door opening portion.
2. Tweeter and sensor harness clip are removed from the duct.

INSTALLATION

Install in the reverse order of removal.
Assemble the following three parts carefully.

(V) Instrument Panel

Tighten the nuts and bolts with each connector put out from the installation part hole when the instrument panel is installed.

(M) Instrument Stay Cover (LH/RH)

Install RH side, and then LH side.

CAUTION:

Be sure to insert the connector.

(I) Instrument Side Finisher (LH/RH)

1. Insert the duct forward first.
2. Slide the instrument side finisher to engage with each metal clip the hole of the instrument panel.

INSTRUMENT PANEL ASSEMBLY

(H) Side Ventilator Assembly (LH/RH)

1. The duct is engaged while rotating the front of side ventilator assembly to a vehicle central side.
2. The metal clips on the other side of side ventilator assembly engaged.

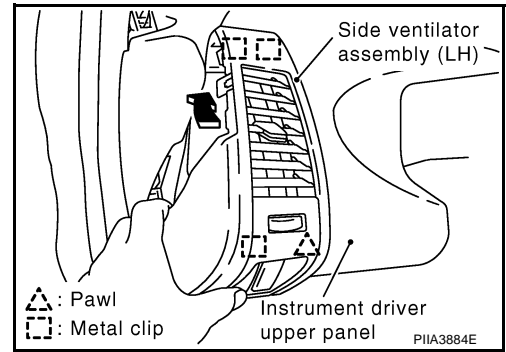

CENTER CONSOLE ASSEMBLY

CENTER CONSOLE ASSEMBLY

PFP:96910

Component Parts Drawing

AIS002HA

A
B
C
D
E
F
G
H
IP
J
K
L
M

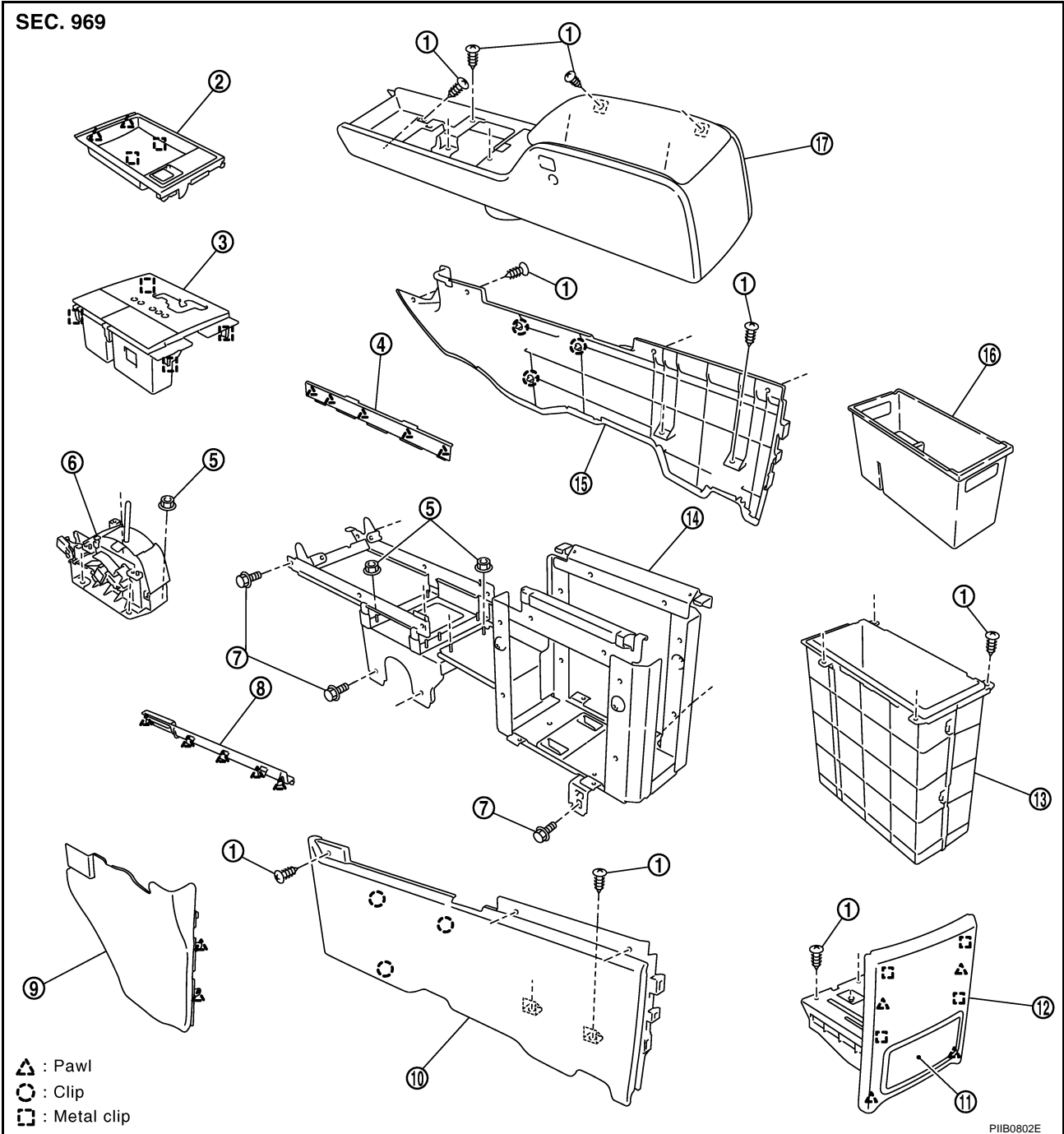

- | | | |
|-------------------------|-----------------------------------|--------------------------------|
| 1. Screw | 2. Console front pocket | 3. A/T console finisher |
| 4. Console mask (RH) | 5. Nut | 6. A/T control device |
| 7. Bolt | 8. Console mask (LH) | 9. Instrument lower cover (LH) |
| 10. Console cover (LH) | 11. Rear cup holder | 12. Console rear cover |
| 13. Console box | 14. Console reinforcement bracket | 15. Console cover (RH) |
| 16. Console rear pocket | 17. Center console | |

CENTER CONSOLE ASSEMBLY

AIS002H2

Removal and Installation

REMOVAL

1. Pull down knob cover.
2. Remove lock pin of selector knob.
3. Lift up select lever knob and remove it. Refer to [CVT-211, "SHIFT CONTROL SYSTEM"](#).
4. Open cup holder lid.
5. Insert a flat-bladed screwdriver wrapped with tape from behind A/T console finisher and remove by lifting.
6. Disconnect harness connector, and remove A/T console finisher.

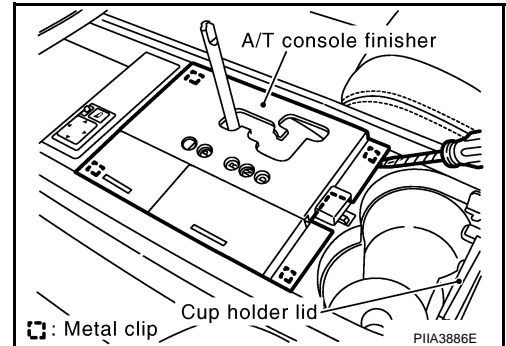

7. Console front pocket is handled lifted, and disengage with the metal clips.
8. Pull up and back to disengage from front pawls.
9. Disconnect harness connector, and remove console front pocket.

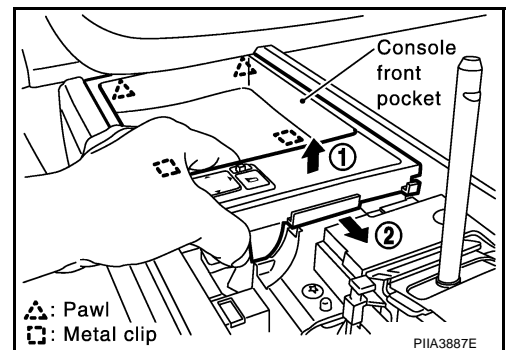

10. Open console lid.
11. Remove console rear pocket.
12. Insert a flat bladed screwdriver wrapped with tape from the space with the console box and remove console mask (LH/RH) by lifting.
13. Remove screws, and remove center console assembly.
14. Remove screws.
15. Disconnect harness connector and remove console box.

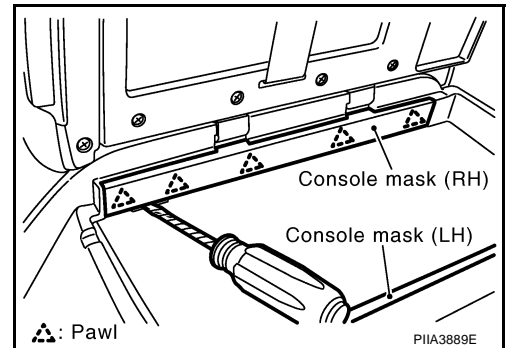

16. Remove screws.
17. Disconnect metal clips and pawls, then remove rear cup holder and console rear cover.

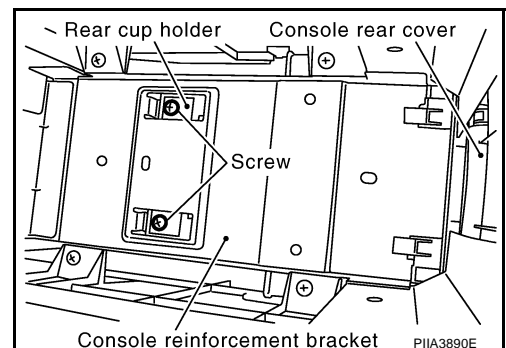

CENTER CONSOLE ASSEMBLY

18. The upper part of rear portion of instrument lower cover is pulled backward, and disengage with pawl is removed.
19. Pull backward and remove instrument lower cover (LH).

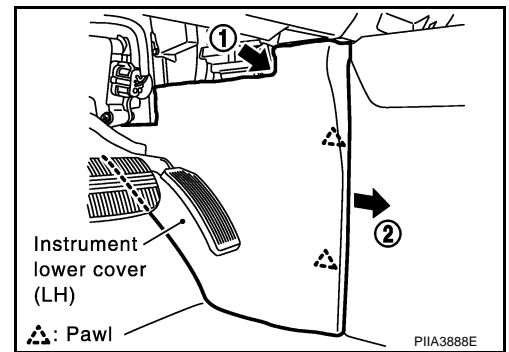

20. Remove screws.
21. Disconnect clips, then remove console cover (LH/RH).
22. Remove nuts, lock plate and control cable. Refer to [CVT-211, "SHIFT CONTROL SYSTEM"](#).
23. Remove bolts and nuts, and remove console reinforcement bracket.

INSTALLATION

Install in the reverse order of removal.

Disassembly and Assembly CENTER CONSOLE

AIS002HB

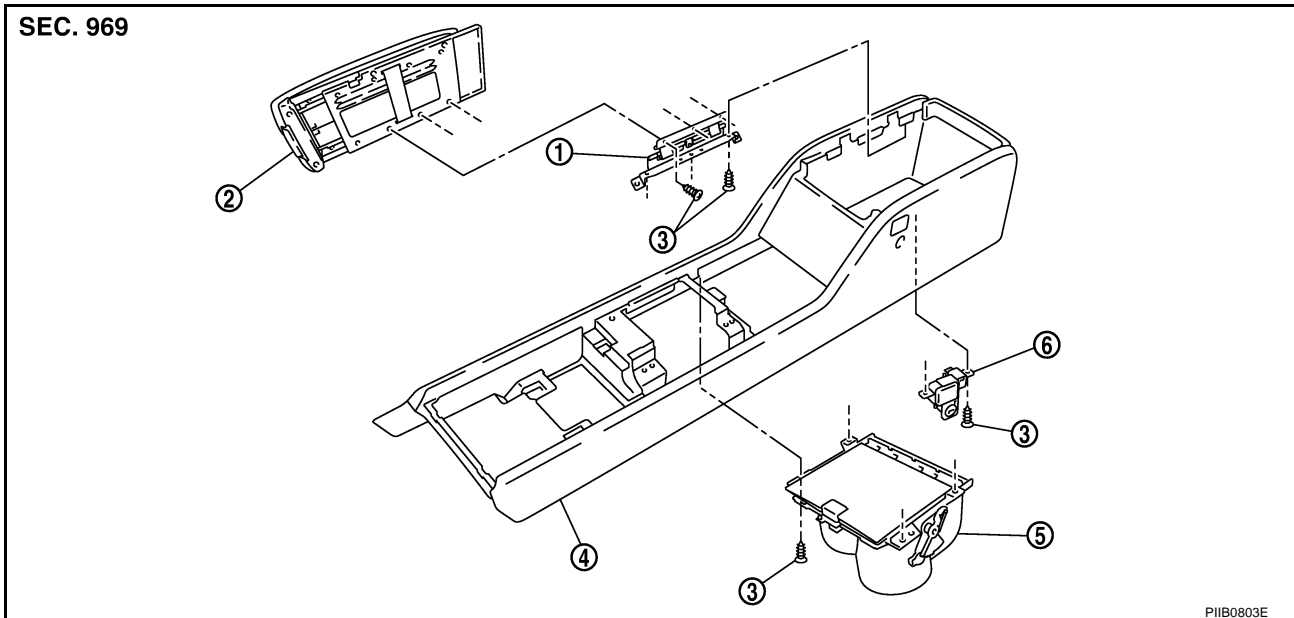

- | | | |
|-------------------|----------------|----------|
| 1. Hinge | 2. Console lid | 3. Screw |
| 4. Center console | 5. Cup holder | 6. Lock |

Disassembly

1. Remove screws fixing cup holder from back side, and then remove it.
2. Remove screws fixing lock from back side, and then remove it.
3. Remove screws fixing console lid to remove it.
4. Remove screws fixing hinge from back side, to remove it.

Assembly

Assemble in the reverse order of disassembly.

CENTER CONSOLE ASSEMBLY
