

SECTION EI
EXTERIOR & INTERIOR

A
 B
 C
 D
 E
 F
 G
 H
EI
 J
 K
 L
 M

CONTENTS

| | | | |
|---|-----------|---|-----------|
| PRECAUTIONS | 3 | FRONT GRILLE | 20 |
| Precautions for Supplemental Restraint System (SRS) "AIR BAG" and "SEAT BELT PRE-TENSIONER" | 3 | Removal and Installation | 20 |
| Precautions for Work | 3 | REMOVAL | 20 |
| PREPARATION | 4 | INSTALLATION | 20 |
| Special Service Tools | 4 | COWL TOP | 21 |
| Commercial Service Tools | 4 | Removal and Installation | 21 |
| SQUEAK AND RATTLE TROUBLE DIAGNOSES | 5 | REMOVAL | 21 |
| Work Flow | 5 | INSTALLATION | 21 |
| CUSTOMER INTERVIEW | 5 | FENDER PROTECTOR | 22 |
| DUPLICATE THE NOISE AND TEST DRIVE | 6 | Removal and Installation | 22 |
| CHECK RELATED SERVICE BULLETINS | 6 | REMOVAL | 22 |
| LOCATE THE NOISE AND IDENTIFY THE ROOT CAUSE | 6 | INSTALLATION | 22 |
| REPAIR THE CAUSE | 6 | DOOR OUTSIDE MOLDING | 23 |
| CONFIRM THE REPAIR | 7 | Removal and Installation | 23 |
| Generic Squeak and Rattle Troubleshooting | 7 | FRONT DOOR OUTSIDE MOLDING | 23 |
| INSTRUMENT PANEL | 7 | REAR DOOR OUTSIDE MOLDING | 23 |
| CENTER CONSOLE | 7 | DOOR OUTSIDE LOWER MOLDING | 24 |
| DOORS | 7 | Removal and Installation | 24 |
| TRUNK | 8 | FRONT DOOR OUTSIDE LOWER MOLDING ... | 24 |
| SUNROOF/HEADLINING | 8 | REAR DOOR OUTSIDE LOWER MOLDING | 24 |
| SEATS | 8 | FRONT FENDER LOWER MOLDING | 24 |
| UNDERHOOD | 8 | DOOR PARTING SEAL | 25 |
| Diagnostic Worksheet | 9 | Removal and Installation | 25 |
| CLIP AND FASTENER | 11 | REMOVAL | 25 |
| Clip and Fastener | 11 | INSTALLATION | 25 |
| FRONT BUMPER | 14 | WINDSHIELD MOLDING | 26 |
| Removal and Installation | 14 | Removal and Installation | 26 |
| REMOVAL | 16 | WINDSHIELD MOLDING | 26 |
| INSTALLATION | 16 | SIDE WINDOW GLASS | 27 |
| REAR BUMPER | 17 | Removal and Installation | 27 |
| Removal and Installation | 17 | SIDE WINDOW MOLDING | 27 |
| REMOVAL | 19 | ROOF SIDE MOLDING | 28 |
| INSTALLATION | 19 | Removal and Installation | 28 |
| REAR BUMPER CLOSING | 19 | REMOVAL | 28 |
| DRAFTER GUARD | 19 | INSTALLATION | 28 |
| | | ROOF RAIL | 29 |
| | | Removal and Installation | 29 |
| | | REMOVAL | 29 |
| | | INSTALLATION | 29 |

| | | | |
|--------------------------------------|-----------|---------------------------------|-----------|
| DOOR FINISHER | 30 | HEADLINING | 36 |
| Removal and Installation | 30 | Removal and Installation | 36 |
| DOOR FINISHER (FRONT AND REAR) | 30 | REMOVAL | 37 |
| BODY SIDE TRIM | 32 | INSTALLATION | 37 |
| Removal and Installation | 32 | LUGGAGE FLOOR TRIM | 38 |
| CENTER PILLAR LOWER GARNISH | 32 | Removal and Installation | 38 |
| CENTER PILLAR UPPER GARNISH | 32 | REMOVAL | 39 |
| DASH SIDE FINISHER | 33 | INSTALLATION | 39 |
| FRONT PILLAR GARNISH | 33 | BACK DOOR TRIM | 40 |
| FRONT AND REAR KICKING PLATE | 33 | Removal and Installation | 40 |
| FRONT AND REAR BODY SIDE WELT | 33 | REMOVAL | 40 |
| FLOOR TRIM | 34 | INSTALLATION | 40 |
| Removal and Installation | 34 | | |
| REMOVAL | 34 | | |
| INSTALLATION | 35 | | |

PRECAUTIONS

PRECAUTIONS

PPF:00001

Precautions for Supplemental Restraint System (SRS) “AIR BAG” and “SEAT BELT PRE-TENSIONER”

AIS005DB

The Supplemental Restraint System such as “AIR BAG” and “SEAT BELT PRE-TENSIONER”, used along with a front seat belt, helps to reduce the risk or severity of injury to the driver and front passenger for certain types of collision. This system includes seat belt switch inputs and dual stage front air bag modules. The SRS system uses the seat belt switches to determine the front air bag deployment, and may only deploy one front air bag, depending on the severity of a collision and whether the front occupants are belted or unbelted. Information necessary to service the system safely is included in the SRS and SB section of this Service Manual.

WARNING:

- To avoid rendering the SRS inoperative, which could increase the risk of personal injury or death in the event of a collision which would result in air bag inflation, all maintenance must be performed by an authorized NISSAN/INFINITI dealer.
- Improper maintenance, including incorrect removal and installation of the SRS, can lead to personal injury caused by unintentional activation of the system. For removal of Spiral Cable and Air Bag Module, see the SRS section.
- Do not use electrical test equipment on any circuit related to the SRS unless instructed to in this Service Manual. SRS wiring harnesses can be identified by yellow and/or orange harnesses or harness connectors.

Precautions for Work

AIS005DC

- After removing and installing the opening/closing parts, be sure to carry out fitting adjustments to check their operation.
- Check the lubrication level, damage, and wear of each part. If necessary, grease or replace it.

A
B
C
D
E
F
G
H
I
J
K
L
M

EI

PREPARATION

PREPARATION

PFP:00002

Special Service Tools

AIS005DD

The actual shapes of Kent-Moore tools may differ from those of special service tools illustrated here.

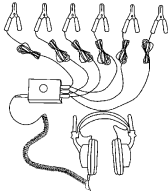
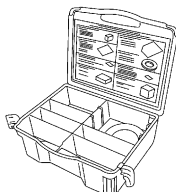
| Tool number (Kent-Moore No.) Tool name | Description |
|---|------------------------------|
| (J-39570) Chassis ear  <p style="text-align: right; margin-right: 20px;">SIIA0993E</p> | Locating the noise |
| (J-43980) NISSAN Squeak and Rattle Kit  <p style="text-align: right; margin-right: 20px;">SIIA0994E</p> | Repairing the cause of noise |

Commercial Service Tools

AIS005DE

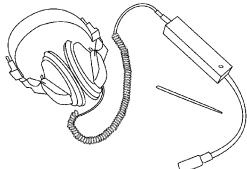
| Tool name | Description |
|---|--------------------|
| Engine ear  <p style="text-align: right; margin-right: 20px;">SIIA0995E</p> | Locating the noise |

SQUEAK AND RATTLE TROUBLE DIAGNOSES

SQUEAK AND RATTLE TROUBLE DIAGNOSES

PPF:00000

Work Flow

AIS005DF

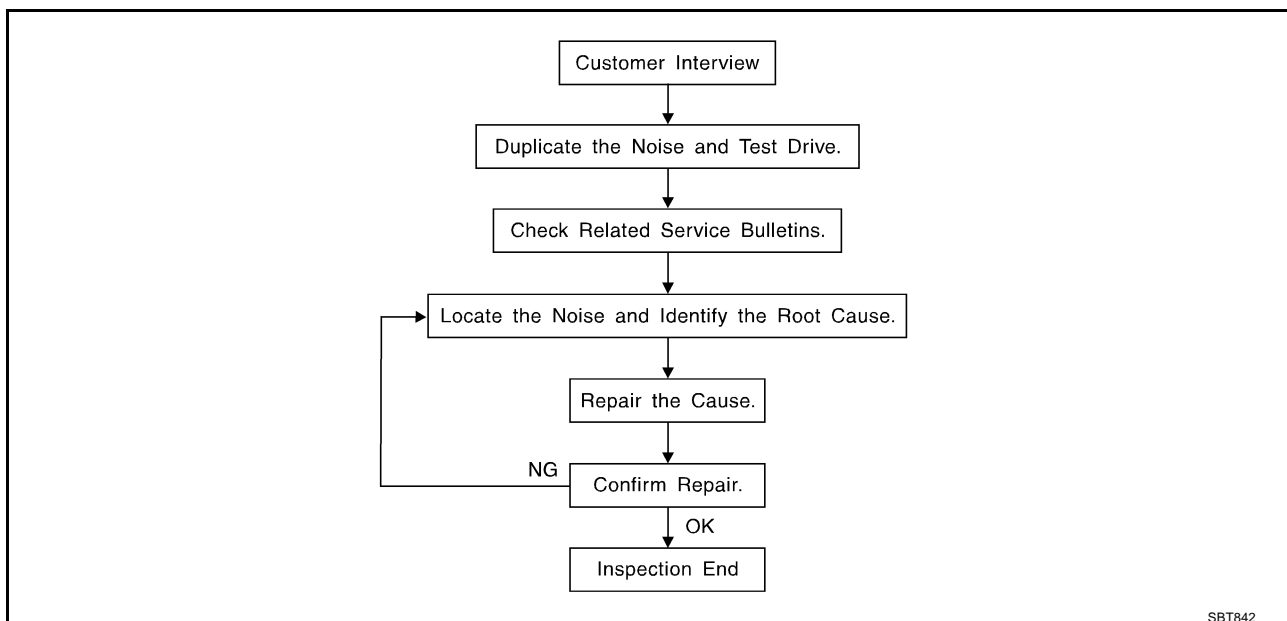

CUSTOMER INTERVIEW

Interview the customer if possible, to determine the conditions that exist when the noise occurs. Use the Diagnostic Worksheet during the interview to document the facts and conditions when the noise occurs and any customer's comments; refer to [EI-9, "Diagnostic Worksheet"](#). This information is necessary to duplicate the conditions that exist when the noise occurs.

- The customer may not be able to provide a detailed description or the location of the noise. Attempt to obtain all the facts and conditions that exist when the noise occurs (or does not occur).
- If there is more than one noise in the vehicle, be sure to diagnose and repair the noise that the customer is concerned about. This can be accomplished by test driving the vehicle with the customer.
- After identifying the type of noise, isolate the noise in terms of its characteristics. The noise characteristics are provided so the customer, service adviser and technician are all speaking the same language when defining the noise.
- Squeak—(Like tennis shoes on a clean floor)
Squeak characteristics include the light contact/fast movement/brought on by road conditions/hard surfaces=higher pitch noise/softer surfaces=lower pitch noises/edge to surface=chirping
- Creak—(Like walking on an old wooden floor)
Creak characteristics include firm contact/slow movement/twisting with a rotational movement/pitch dependent on materials/often brought on by activity.
- Rattle—(Like shaking a baby rattle)
Rattle characteristics include the fast repeated contact/vibration or similar movement/loose parts/missing clip or fastener/incorrect clearance.
- Knock—(Like a knock on a door)
Knock characteristics include hollow sounding/sometimes repeating/often brought on by driver action.
- Tick—(Like a clock second hand)
Tick characteristics include gentle contacting of light materials/loose components/can be caused by driver action or road conditions.
- Thump—(Heavy, muffled knock noise)
Thump characteristics include softer knock/dead sound often brought on by activity.
- Buzz—(Like a bumble bee)
Buzz characteristics include high frequency rattle/firm contact.
- Often the degree of acceptable noise level will vary depending upon the person. A noise that you may judge as acceptable may be very irritating to the customer.
- Weather conditions, especially humidity and temperature, may have a great effect on noise level.

SQUEAK AND RATTLE TROUBLE DIAGNOSES

DUPLICATE THE NOISE AND TEST DRIVE

If possible, drive the vehicle with the customer until the noise is duplicated. Note any additional information on the Diagnostic Worksheet regarding the conditions or location of the noise. This information can be used to duplicate the same conditions when you confirm the repair.

If the noise can be duplicated easily during the test drive, to help identify the source of the noise, try to duplicate the noise with the vehicle stopped by doing one or all of the following:

- 1) Close a door.
 - 2) Tap or push/pull around the area where the noise appears to be coming from.
 - 3) Rev the engine.
 - 4) Use a floor jack to recreate vehicle "twist".
 - 5) At idle, apply engine load (electrical load, half-clutch on M/T model, drive position on A/T model).
 - 6) Raise the vehicle on a hoist and hit a tire with a rubber hammer.
- Drive the vehicle and attempt to duplicate the conditions the customer states exist when the noise occurs.
 - If it is difficult to duplicate the noise, drive the vehicle slowly on an undulating or rough road to stress the vehicle body.

CHECK RELATED SERVICE BULLETINS

After verifying the customer concern or symptom, check ASIST for Technical Service Bulletins (TSBs) related to that concern or symptom.

If a TSB relates to the symptom, follow the procedure to repair the noise.

LOCATE THE NOISE AND IDENTIFY THE ROOT CAUSE

1. Narrow down the noise to a general area. To help pinpoint the source of the noise, use a listening tool (Chassis Ear: J39570, Engine Ear and mechanics stethoscope).
2. Narrow down the noise to a more specific area and identify the cause of the noise by:
 - removing the components in the area that you suspect the noise is coming from.
Do not use too much force when removing clips and fasteners, otherwise clips and fastener can be broken or lost during the repair, resulting in the creation of new noise.
 - tapping or pushing/pulling the component that you suspect is causing the noise.
Do not tap or push/pull the component with excessive force, otherwise the noise will be eliminated only temporarily.
 - feeling for a vibration with your hand by touching the component(s) that you suspect is (are) causing the noise.
 - placing a piece of paper between components that you suspect are causing the noise.
 - looking for loose components and contact marks.
Refer to [EI-7, "Generic Squeak and Rattle Troubleshooting"](#).

REPAIR THE CAUSE

- If the cause is a loose component, tighten the component securely.
- If the cause is insufficient clearance between components:
 - separate components by repositioning or loosening and retightening the component, if possible.
 - insulate components with a suitable insulator such as urethane pads, foam blocks, felt cloth tape or urethane tape. A Nissan Squeak and Rattle Kit (J-43980) is available through your authorized Nissan Parts Department.

CAUTION:

Do not use excessive force as many components are constructed of plastic and may be damaged.

Always check with the Parts Department for the latest parts information.

The following materials are contained in the Nissan Squeak and Rattle Kit (J-43980). Each item can be ordered separately as needed.

URETHANE PADS [1.5 mm (0.059 in) thick]

Insulates connectors, harness, etc.

76268-9E005: 100 × 135 mm (3.94 × 5.31 in)/76884-71L01: 60×85 mm (2.36 × 3.35 in)/76884-71L02: 15 × 25 mm (0.59 × 0.98 in)

INSULATOR (Foam blocks)

Insulates components from contact. Can be used to fill space behind a panel.

73982-9E000: 45 mm (1.77 in) thick, 50 × 50 mm (1.97 × 1.97 in)/73982-50Y00: 10 mm (0.39 in) thick, 50 × 50 mm (1.97 × 1.97 in)

SQUEAK AND RATTLE TROUBLE DIAGNOSES

INSULATOR (Light foam block)

80845-71L00: 30 mm (1.18 in) thick, 30 × 50 mm (1.18 × 1.97 in)

FELT CLOTHTAPE

Used to insulate where movement does not occur. Ideal for instrument panel applications.

68370-4B000: 15 × 25 mm (0.59 × 0.98 in) pad/68239-13E00: 5 mm (0.20 in) wide tape roll

The following materials, not found in the kit, can also be used to repair squeaks and rattles.

UHMW(TEFLON) TAPE

Insulates where slight movement is present. Ideal for instrument panel applications.

SILICONE GREASE

Used in place of UHMW tape that will be visible or not fit.

Note: Will only last a few months.

SILICONE SPRAY

Use when grease cannot be applied.

DUCT TAPE

Use to eliminate movement.

CONFIRM THE REPAIR

Confirm that the cause of a noise is repaired by test driving the vehicle. Operate the vehicle under the same conditions as when the noise originally occurred. Refer to the notes on the Diagnostic Worksheet.

Generic Squeak and Rattle Troubleshooting

AI5005DG

Refer to Table of Contents for specific component removal and installation information.

INSTRUMENT PANEL

Most incidents are caused by contact and movement between:

1. Cluster lid A and instrument panel
2. Acrylic lens and combination meter housing
3. Instrument panel to front pillar garnish
4. Instrument panel to windshield
5. Instrument panel mounting pins
6. Wiring harnesses behind the combination meter
7. A/C defroster duct and duct joint

These incidents can usually be located by tapping or moving the components to duplicate the noise or by pressing on the components while driving to stop the noise. Most of these incidents can be repaired by applying felt cloth tape or silicon spray (in hard to reach areas). Urethane pads can be used to insulate wiring harness.

CAUTION:

Do not use silicone spray to isolate a squeak or rattle. If you saturate the area with silicone, you will not be able to recheck the repair.

CENTER CONSOLE

Components to pay attention to include:

1. Shifter assembly cover to finisher
2. A/C control unit and cluster lid C
3. Wiring harnesses behind audio and A/C control unit

The instrument panel repair and isolation procedures also apply to the center console.

DOORS

Pay attention to the:

1. Finisher and inner panel making a slapping noise
2. Inside handle escutcheon to door finisher
3. Wiring harnesses tapping
4. Door striker out of alignment causing a popping noise on starts and stops

Tapping or moving the components or pressing on them while driving to duplicate the conditions can isolate many of these incidents. You can usually insulate the areas with felt cloth tape or insulator foam blocks from the Nissan Squeak and Rattle Kit (J-43980) to repair the noise.

SQUEAK AND RATTLE TROUBLE DIAGNOSES

TRUNK

Trunk noises are often caused by a loose jack or loose items put into the trunk by the owner. In addition look for:

1. Trunk lid dumpers out of adjustment
2. Trunk lid striker out of adjustment
3. Trunk lid torsion bars knocking together
4. A loose license plate or bracket

Most of these incidents can be repaired by adjusting, securing or insulating the item(s) or component(s) causing the noise.

SUNROOF/HEADLINING

Noises in the sunroof/headlining area can often be traced to one of the following:

1. Sunroof lid, rail, linkage or seals making a rattle or light knocking noise
2. Sunvisor shaft shaking in the holder
3. Front or rear windshield touching headlining and squeaking

Again, pressing on the components to stop the noise while duplicating the conditions can isolate most of these incidents. Repairs usually consist of insulating with felt cloth tape.

SEATS

When isolating seat noise it's important to note the position the seat is in and the load placed on the seat when the noise is present. These conditions should be duplicated when verifying and isolating the cause of the noise.

Cause of seat noise include:

1. Headrest rods and holder
2. A squeak between the seat pad cushion and frame
3. Rear seatback lock and bracket

These noises can be isolated by moving or pressing on the suspected components while duplicating the conditions under which the noise occurs. Most of these incidents can be repaired by repositioning the component or applying urethane tape to the contact area.

UNDERHOOD

Some interior noise may be caused by components under the hood or on the engine wall. The noise is then transmitted into the passenger compartment.

Causes of transmitted underhood noise include:

1. Any component mounted to the engine wall
2. Components that pass through the engine wall
3. Engine wall mounts and connectors
4. Loose radiator mounting pins
5. Hood bumpers out of adjustment
6. Hood striker out of adjustment

These noises can be difficult to isolate since they cannot be reached from the interior of the vehicle. The best method is to secure, move or insulate one component at a time and test drive the vehicle. Also, engine RPM or load can be changed to isolate the noise. Repairs can usually be made by moving, adjusting, securing, or insulating the component causing the noise.

SQUEAK AND RATTLE TROUBLE DIAGNOSES

Diagnostic Worksheet

AIS005DH

A
B
C
D
E
F
G
H
EI
J
K
L
M

SQUEAK & RATTLE DIAGNOSTIC WORKSHEET

Dear Nissan Customer:

We are concerned about your satisfaction with your Nissan vehicle. Repairing a squeak or rattle sometimes can be very difficult. To help us fix your Nissan right the first time, please take a moment to note the area of the vehicle where the squeak or rattle occurs and under what conditions. You may be asked to take a test drive with a service advisor or technician to ensure we confirm the noise you are hearing.

I. WHERE DOES THE NOISE COME FROM? (circle the area of the vehicle)

The illustrations are for reference only, and may not reflect the actual configuration of your vehicle.

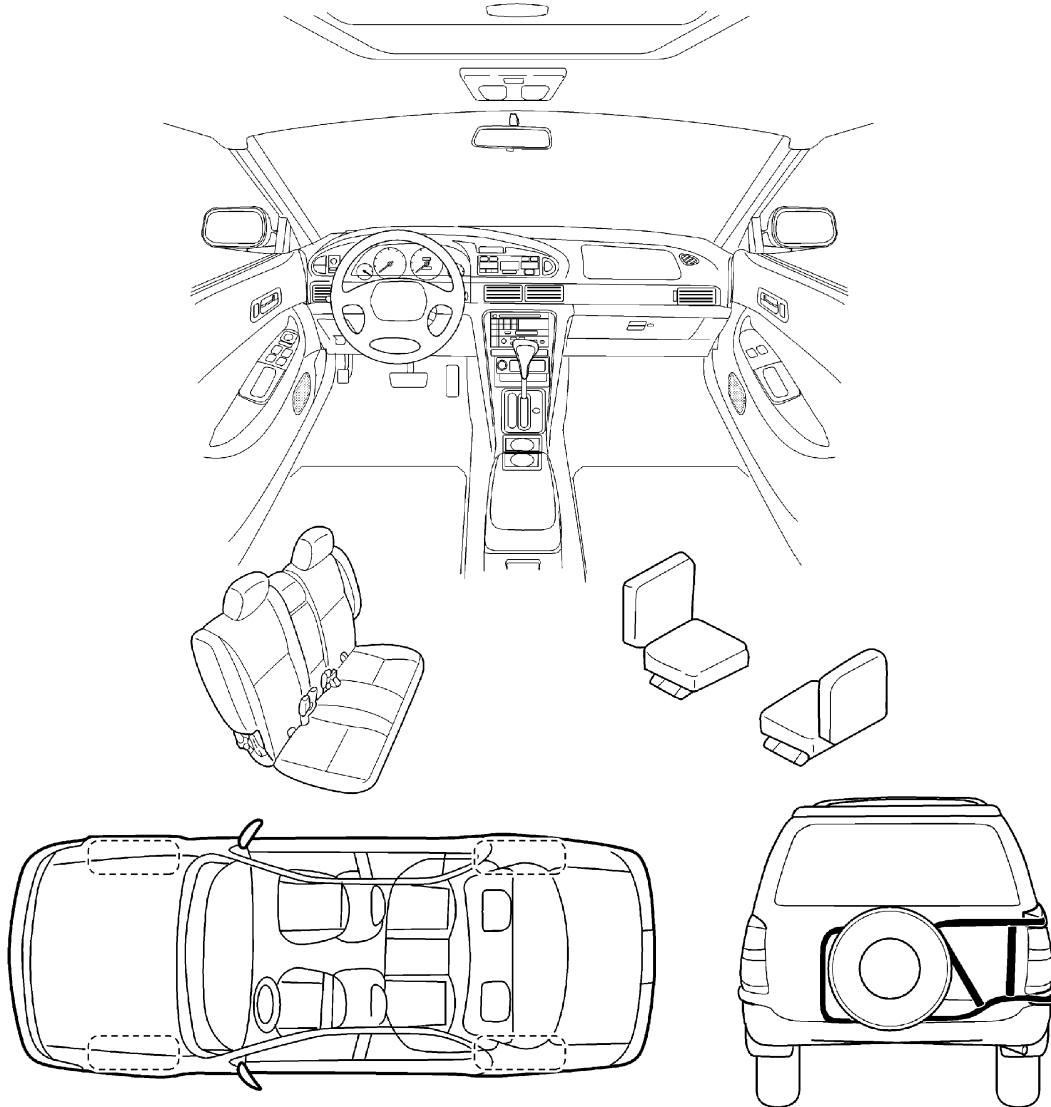

Continue to the back of the worksheet and briefly describe the location of the noise or rattle. In addition, please indicate the conditions which are present when the noise occurs.

PIIB0723E

SQUEAK AND RATTLE TROUBLE DIAGNOSES

SQUEAK & RATTLE DIAGNOSTIC WORKSHEET- page 2

Briefly describe the location where the noise occurs:

II. WHEN DOES IT OCCUR? (check the boxes that apply)

- | | |
|--|---|
| <input type="checkbox"/> anytime | <input type="checkbox"/> after sitting out in the sun |
| <input type="checkbox"/> 1 st time in the morning | <input type="checkbox"/> when it is raining or wet |
| <input type="checkbox"/> only when it is cold outside | <input type="checkbox"/> dry or dusty conditions |
| <input type="checkbox"/> only when it is hot outside | <input type="checkbox"/> other: _____ |

III. WHEN DRIVING:

- through driveways
- over rough roads
- over speed bumps
- only at about ____ mph
- on acceleration
- coming to a stop
- on turns : left, right or either (circle)
- with passengers or cargo
- other: _____
- after driving ____ miles or ____ minutes

IV. WHAT TYPE OF NOISE?

- squeak (like tennis shoes on a clean floor)
- creak (like walking on an old wooden floor)
- rattle (like shaking a baby rattle)
- knock (like a knock on a door)
- tick (like a clock second hand)
- thump (heavy, muffled knock noise)
- buzz (like a bumble bee)

TO BE COMPLETED BY DEALERSHIP PERSONNEL

Test Drive Notes:

| | YES | NO | Initials of person performing |
|--|--------------------------|--------------------------|-------------------------------|
| Vehicle test driven with customer | <input type="checkbox"/> | <input type="checkbox"/> | _____ |
| - Noise verified on test drive | <input type="checkbox"/> | <input type="checkbox"/> | _____ |
| - Noise source located and repaired | <input type="checkbox"/> | <input type="checkbox"/> | _____ |
| - Follow up test drive performed to confirm repair | <input type="checkbox"/> | <input type="checkbox"/> | _____ |

VIN: _____ Customer Name: _____

W.O. #: _____ Date: _____

This form must be attached to Work Order

SBT844







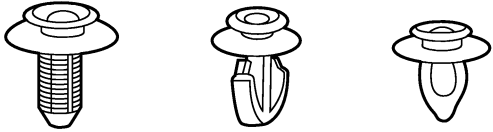
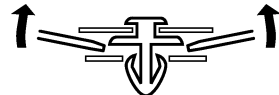

CLIP AND FASTENER

CLIP AND FASTENER

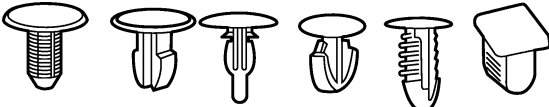
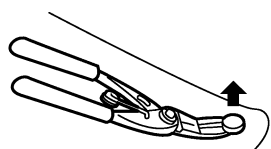
PFP:76906

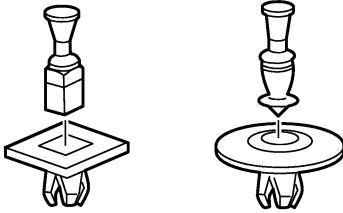
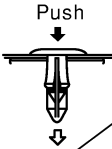
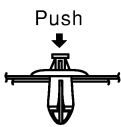
Clip and Fastener

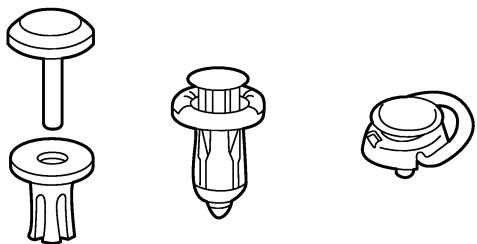

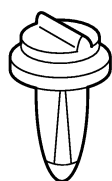
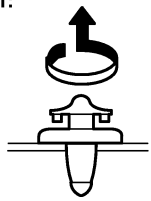





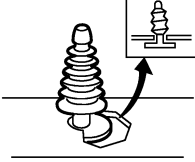
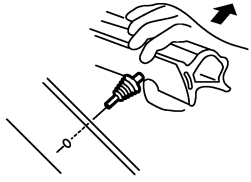

AIS002A2

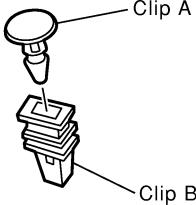
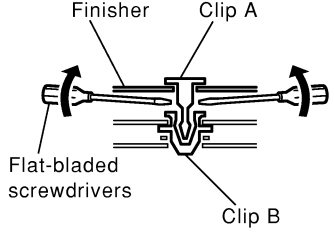
| Symbol No. | Shapes | Removal & Installation |
|---|---|--|
| <p>C101</p>  |  | <p>Removal: Remove by bending up with flat-bladed screwdrivers or clip remover.</p>  |
| <p>C103</p>  |  | <p>Removal: Remove with a clip remover.</p>  |
| <p>C203</p>  |  | <p>Removal: Push center pin to catching position. (Do not remove center pin by hitting it.)</p> <p>Push</p>  <p>Installation:</p> <p>Push</p>  |
| <p>C205</p>  |  | <p>Removal: Flat-bladed screwdriver</p>  <p>Clip</p> <p>Finisher</p> |
| <p>C206</p>  |  | <p>Removal:</p>  |

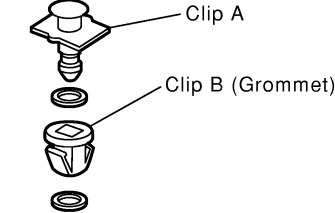
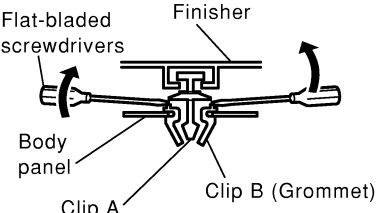
A
B
C
D
E
F
G
H
EI
J
K
L
M

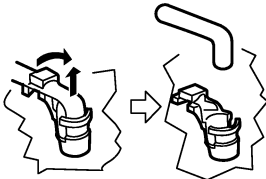

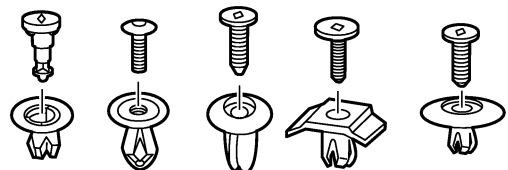







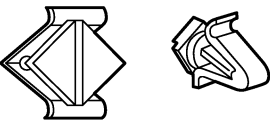

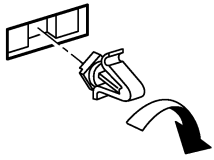
SIIA0315E

CLIP AND FASTENER

| Symbol No. | Shapes | Removal & Installation |
|--|--|--|
| <p>CE103</p>  |  | <p>Removal:</p>  |
| <p>CF110</p>  |  <p>Clip A</p> <p>Clip B</p> | <p>Removal:</p>  <p>Finisher</p> <p>Clip A</p> <p>Flat-bladed screwdrivers</p> <p>Clip B</p> |
| <p>CF118</p>  |  <p>Clip A</p> <p>Clip B (Grommet)</p> | <p>Removal:</p>  <p>Flat-bladed screwdrivers</p> <p>Finisher</p> <p>Body panel</p> <p>Clip A</p> <p>Clip B (Grommet)</p> |
| <p>CR103</p>  |  | <p>Removal: Holder portion of clip must be spread out to remove rod.</p>  |
| <p>CS101</p>  |  | <p>Removal:</p> <ol style="list-style-type: none"> 1. Screw out with a Phillips screwdriver. 2. Remove female portion with flat-bladed screwdriver.  |

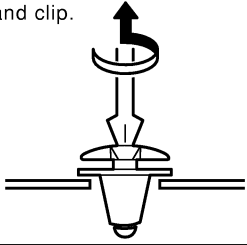
SIIA0316E

CLIP AND FASTENER

| Symbol No. | Shapes | Removal & Installation | |
|--|---|--|---|
| <p>CG101</p>  |  | <p>Removal:</p>  <p>Rotate 45° to remove</p> | <p>Installation:</p>  |
| <p>CS102</p>  |  |  | |
| <p>CS113</p>  |  | <p>Removal: Disconnect upper connection of clip with a flat-bladed screwdriver, then remove clip while inserting a flat-bladed screwdriver between body panel and clip.</p>  | |
| <p>C111</p>  |  |  | |

A
B
C
D
E
F
G
H
EI
J
K
L
M

SIIA0317E

FRONT BUMPER

FRONT BUMPER

PF2:F2022

Removal and Installation

AI002A3

CAUTION:

Bumper fascia is made of resin. Do not apply strong force to it, and be careful to prevent contact with oil.

FRONT BUMPER

SEC. 620

A
B
C
D
E
F
G
H
EI
J
K
L
M

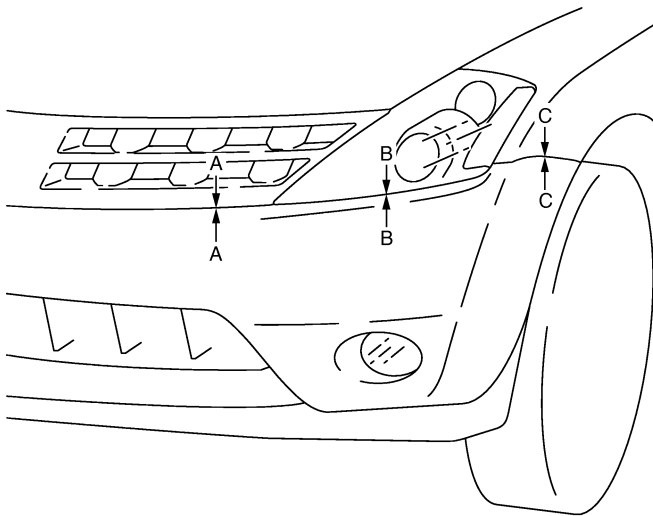
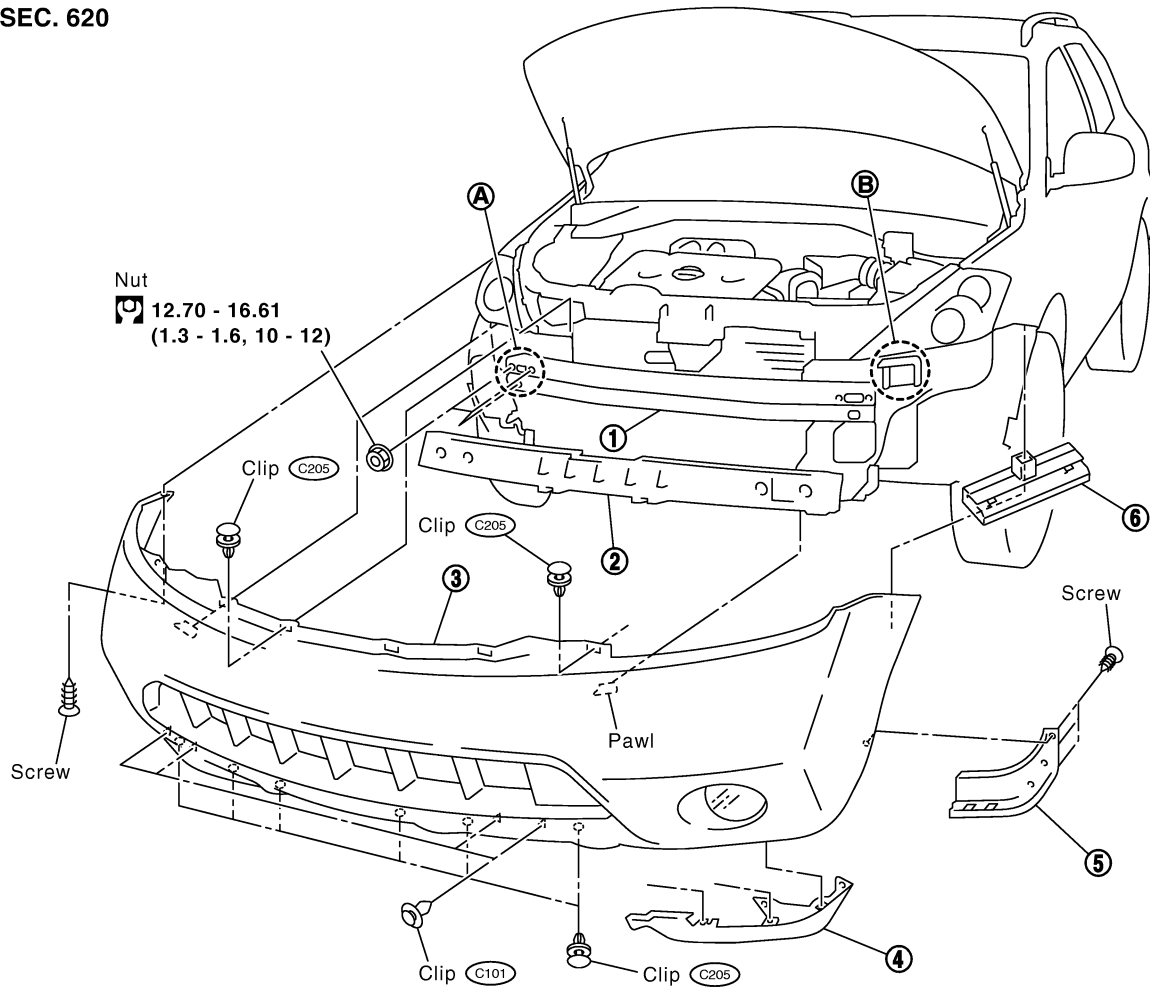

Clearance measurement
between parts
A - A: 0.5 - 3.5 (0.020 - 0.138)
B - B: 1.5 - 4.5 (0.059 - 0.177)
C - C: 0 - 1.0 (0 - 0.04)
Unit: mm (in)

: N•m (kg-m, ft-lb)

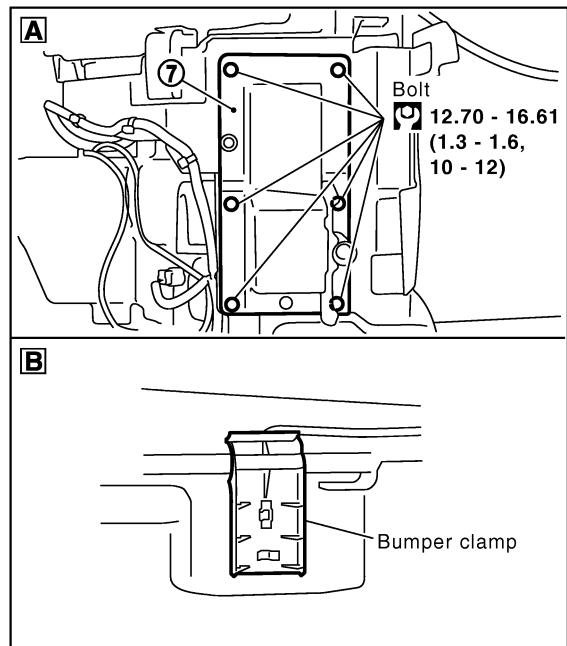

PIIA3829E

1. Bumper reinforcement

2. Energy absorber

3. Bumper fascia assembly

FRONT BUMPER

- 4. Bumper guard
- 5. Bumper finisher
- 6. Bumper side bracket
- 7. Bumper stay

REMOVAL

1. Remove bumper clips, front grille clips, and remove front grille.
2. Remove bolts and clips on lower side of bumper.
3. Remove screws and clips of both right/left fender protectors on front side. Refer to [EI-22, "Removal and Installation"](#) .
4. Remove screws of both right/left fender and remove bumper fascia assembly.
5. Remove front bumper energy absorber.
6. Remove nuts of bumper reinforcement.
7. Remove fog lamps located in bumper fascia. Refer to [LT-122, "Removal and Installation"](#) .

INSTALLATION

Install in the reverse order of removal.

REAR BUMPER

REAR BUMPER

PFP:H5022

Removal and Installation

AIS002A4

CAUTION:

Bumper fascia is made of resin. Do not apply strong force to it, and be careful to prevent contact with oil.

A

B

C

D

E

F

G

H

EI

J

K

L

M

REAR BUMPER

SEC. 850

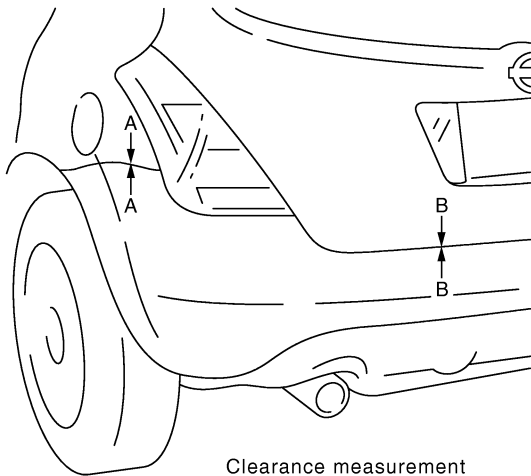
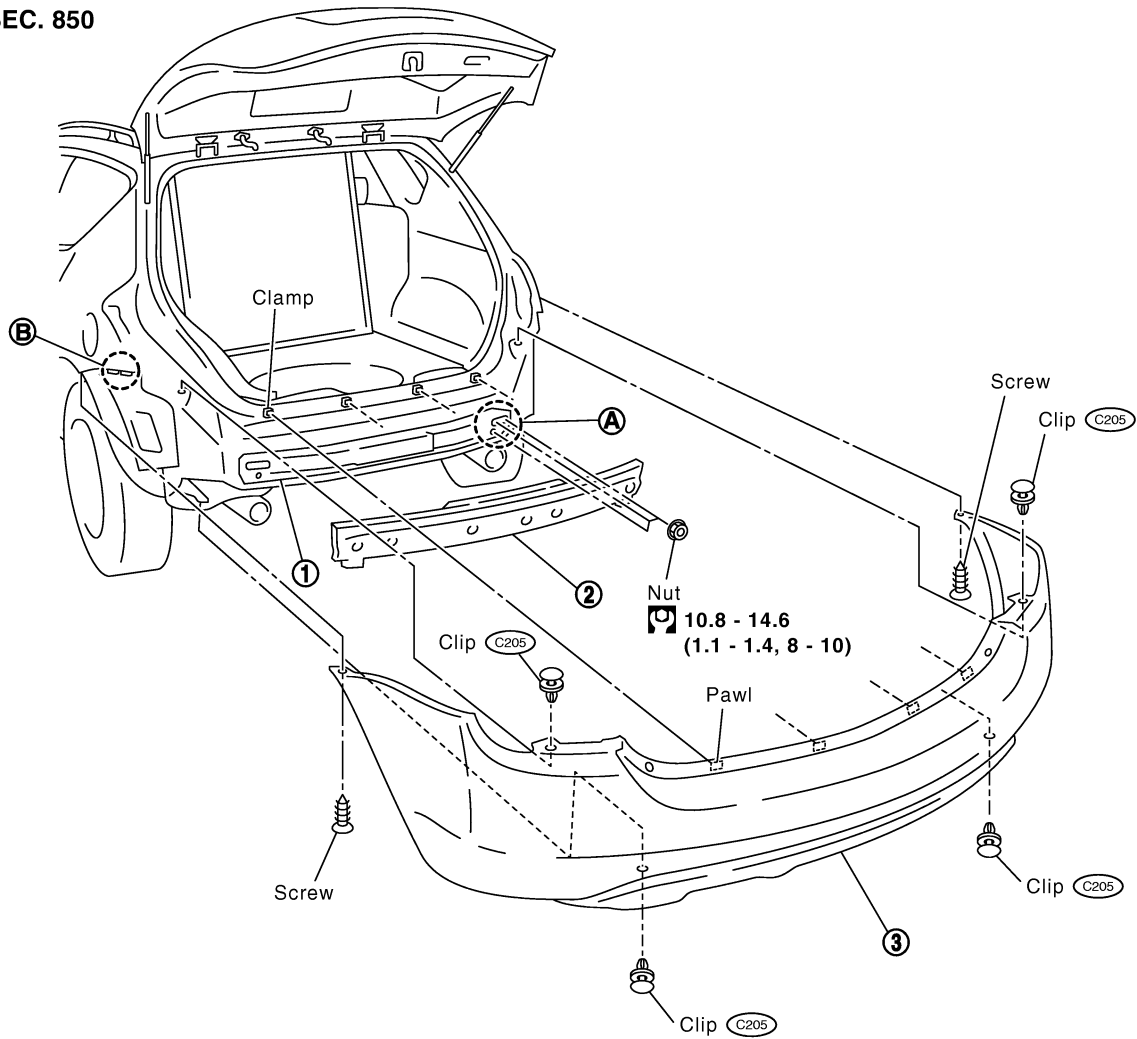

Clearance measurement between parts
 A - A: 0 - 1.0 (0 - 0.04)
 B - B: 6 - 10 (0.24 - 0.39)
 Unit: mm (in)

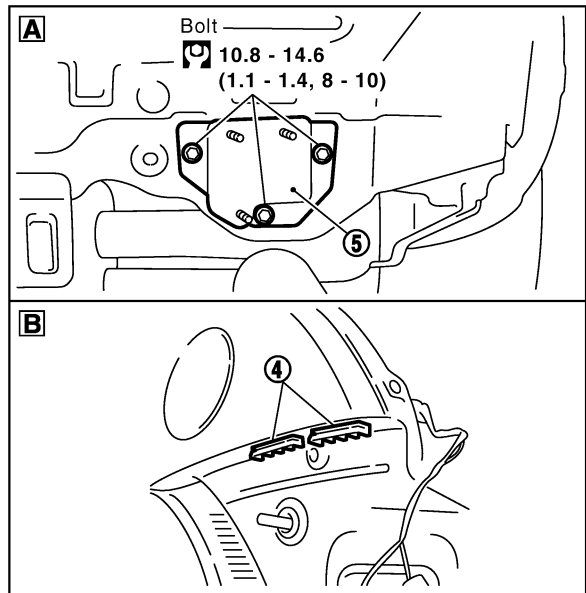

: N•m (kg-m, ft-lb)

PIIA3830E

- 1. Bumper reinforcement
- 4. Bumper side bracket

- 2. Energy absorber
- 5. Bumper stay

- 3. Bumper fascia assembly

REAR BUMPER

REMOVAL

1. Remove rear combination lamp assembly. Refer to [LT-170, "Removal and Installation"](#) .
2. Remove bumper fascia bolts from both right/left rear fender.
3. Remove upper portion of bumper fascia clips, and remove clips of lower portion.
4. Pull out center of bumper fascia, and pull out side of bumper fascia from clips.
5. Remove bumper fascia assembly.
6. Remove rear bumper energy absorber.
7. Remove bumper reinforcement nuts and remove bumper reinforce assembly.

INSTALLATION

Install in the reverse order of removal.

REAR BUMPER CLOSING

Removal

1. Remove clips of bumper closing.
2. Remove bumper closing.

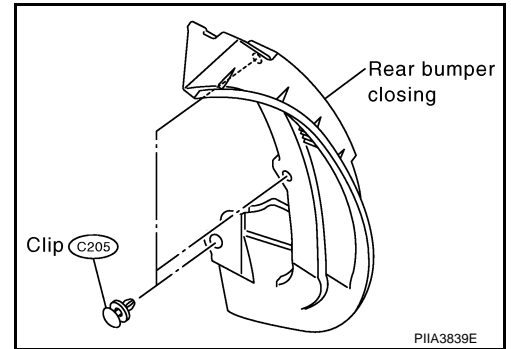

Installation

Install in the reverse order of removal.

DRAFTER GUARD

Removal

1. Remove nut and bolt of drafter guard.
2. Remove drafter guard assembly.

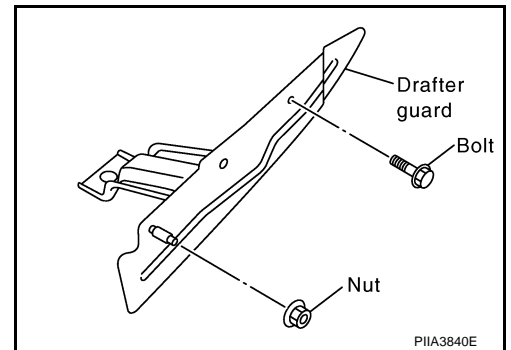

Installation

Install in the reverse order of removal.

A
B
C
D
E
F
G
H
EI
J
K
L
M

FRONT GRILLE

FRONT GRILLE

PFP:62310

Removal and Installation

AIS002A5

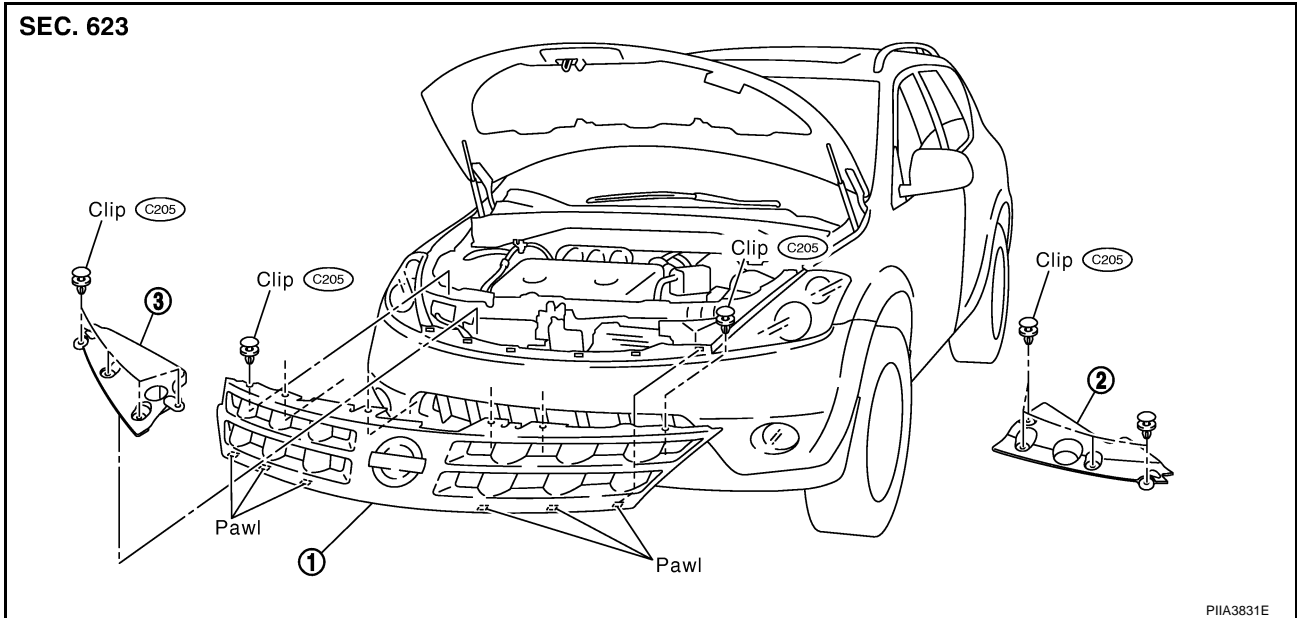

1. Front grille

2. Front grille-radiator cover (left)

3. Front grille-radiator cover (right)

REMOVAL

1. Apply protection tape around outer circumference of front grille (bumper fascia side).
2. Remove front grille-radiator cover clips and remove front grille-radiator cover.
3. Remove clips on upper side of front grille.
4. Pull out grille pawls, and remove front grille assembly.

INSTALLATION

Install in the reverse order of removal.

COWL TOP

COWL TOP

PFP:66100

Removal and Installation

AI/S002A6

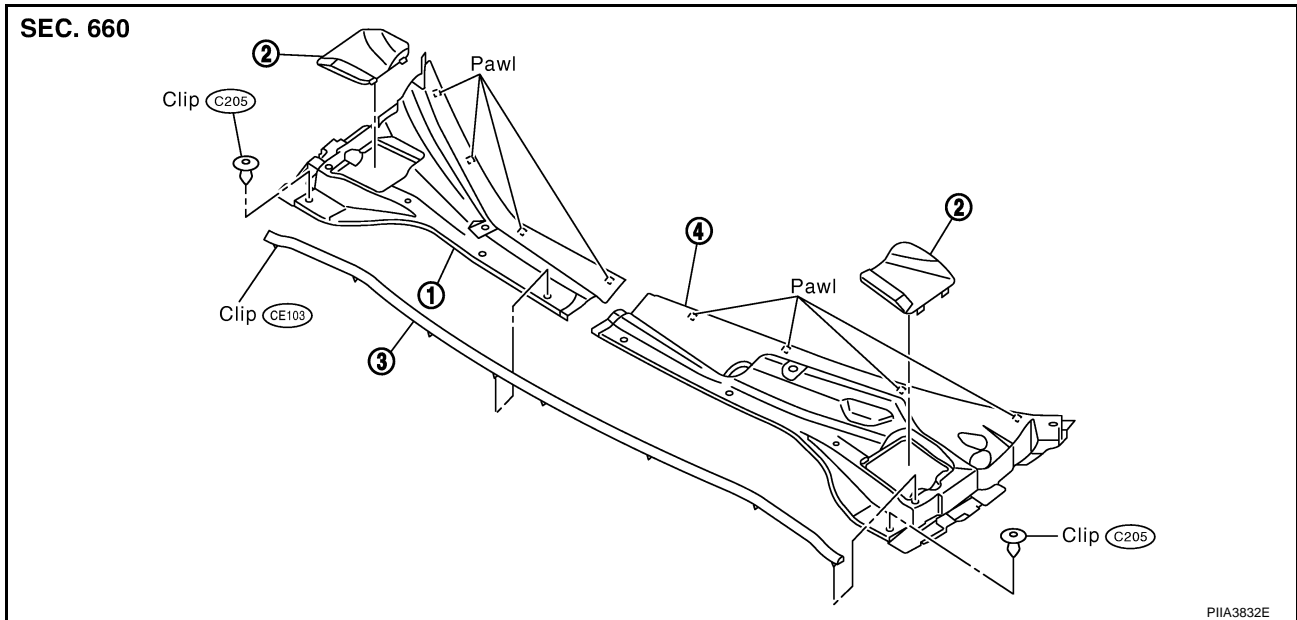

1. Cowl top cover (right)
2. Cap (left / right)
3. Cowl top seal rubber
4. Cowl top cover (left)

REMOVAL

1. Remove both right/left wiper arms. Refer to [WW-32, "Removal and Installation of Front Wiper Arms, Adjustment of Wiper Arms Stop Location"](#).
2. Remove cowl top seal rubber.
3. Remove clips of cowl top cover and remove cowl top cover (right).
4. Remove clips of cowl top cover and remove cowl top cover (left).
5. Remove washer nozzles and hose from cowl top cover.

INSTALLATION

Install in the reverse order of removal.

FENDER PROTECTOR

FENDER PROTECTOR Removal and Installation

PFP:63840

AI/S002A7

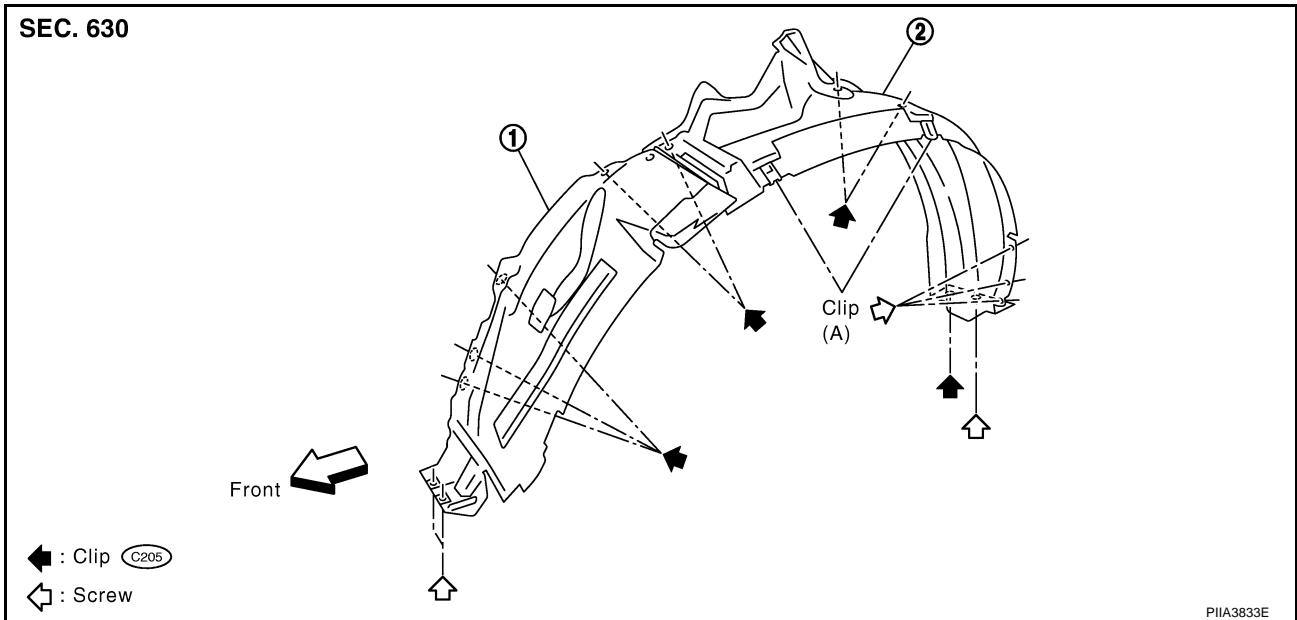

1. Fender protector (front)

2. Fender protector (rear)

REMOVAL

1. Remove screws of fender protector.
2. Remove clips of fender protector.
3. Remove fender protector (front/rear).

INSTALLATION

Install in the reverse order of removal.

DOOR OUTSIDE MOLDING

PPF:82820

DOOR OUTSIDE MOLDING

Removal and Installation

AIS002A8

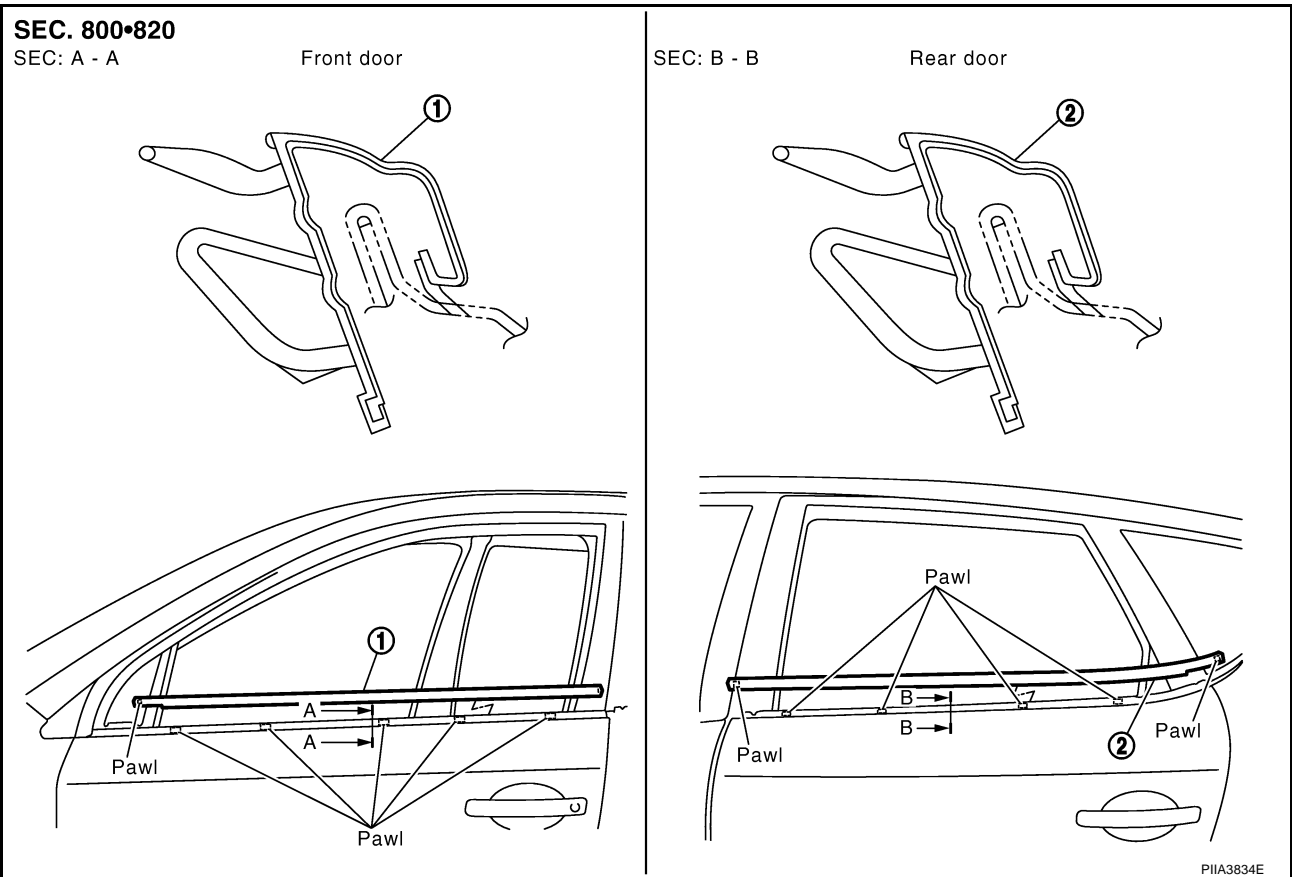

1. Front door outside molding 2. Rear door outside molding

FRONT DOOR OUTSIDE MOLDING

Removal

1. Open windows fully.
2. Disengage front door outside molding pawl.
3. Reaching from inner side of door use a clip tool to disengage front door outside molding from the pawl.

NOTE:

Insert clip clamp tool into the door pawl, then disengage by pressing in the direction of arrow (see figure on the right).

Installation

Install in the reverse order of removal.

REAR DOOR OUTSIDE MOLDING

Removal

1. Open windows fully.
2. Disengage rear door outside molding pawl.
3. Reaching from inner side of door use a clip tool to disengage rear door outside molding from the pawl.

NOTE:

Insert clip clamp tool into the door pawl, then disengage by pressing in the direction of arrow (see figure on the right).

Installation

Install in the reverse order of removal.

A
B
C
D
E
F
G
H
EI
J
K
L
M

DOOR OUTSIDE LOWER MOLDING

DOOR OUTSIDE LOWER MOLDING

PFP:82877

Removal and Installation

AIS002BQ

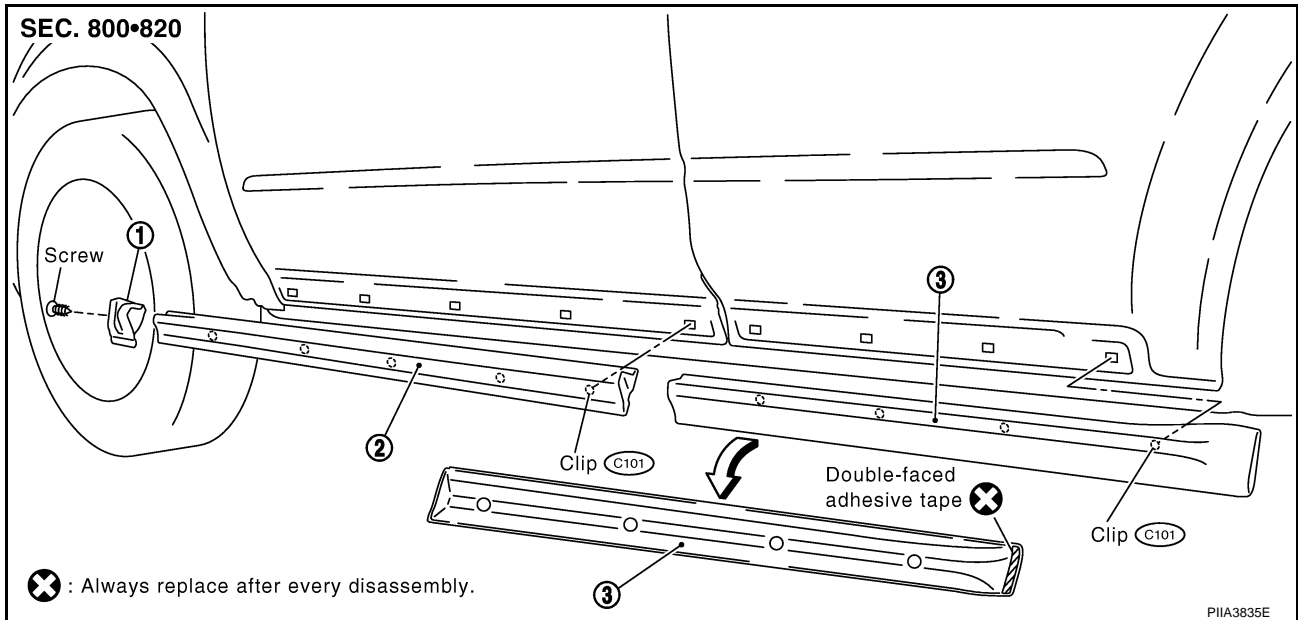

1. Front fender lower molding

2. Front door lower molding

3. Rear door lower molding

FRONT DOOR OUTSIDE LOWER MOLDING

Removal

Remove to slide molding to vehicle backward side, after disconnecting all clips.

Installation

Install in the reverse order of removal.

REAR DOOR OUTSIDE LOWER MOLDING

Removal

Remove to slide molding to vehicle backward side, after disconnecting all clips.

Installation

Install in the reverse order of removal.

FRONT FENDER LOWER MOLDING

Removal

Remove screw, and remove front fender lower molding.

Installation

Install in the reverse order of removal.

DOOR PARTING SEAL

DOOR PARTING SEAL Removal and Installation

PFP:80838

AIS002A9

A
B
C
D
E
F
G
H
EI
J
K
L
M

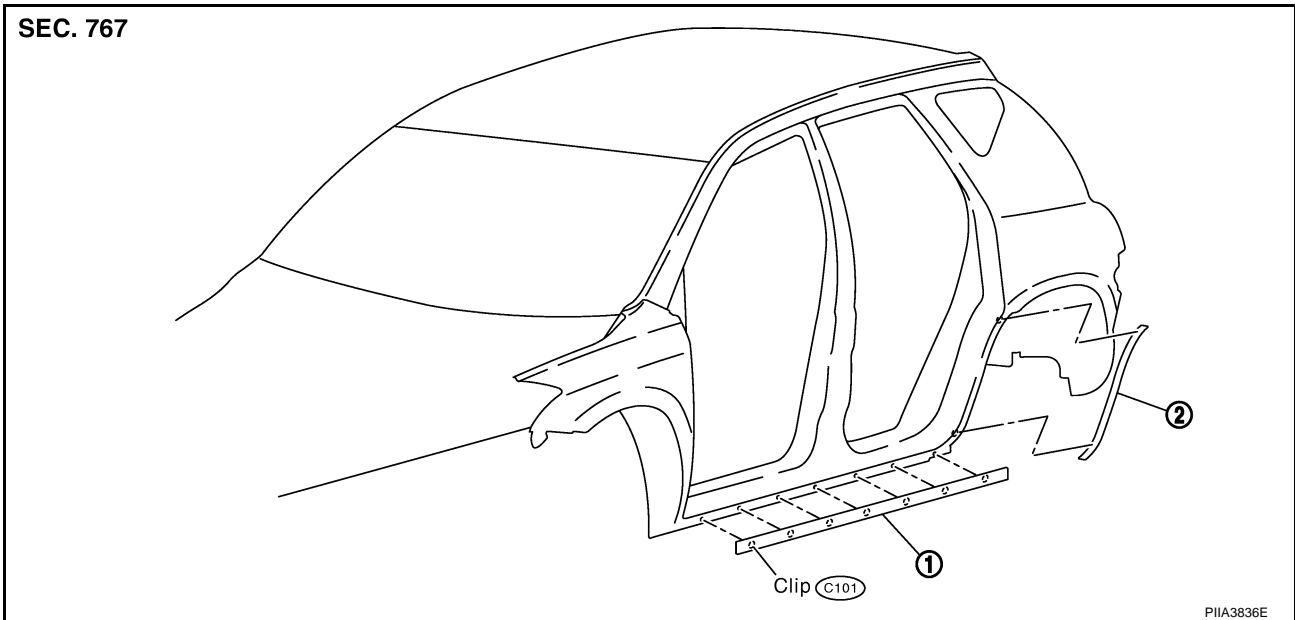

1. Door parting seal rubber
2. Rear door parting seal rubber

REMOVAL

1. Open front door and rear door fully.
2. Remove seal clips and remove door parting seal.
3. Remove rear door parting seal.

INSTALLATION

Install in the reverse order of removal.

WINDSHIELD MOLDING

PFP:72700

AIS005DI

WINDSHIELD MOLDING

Removal and Installation

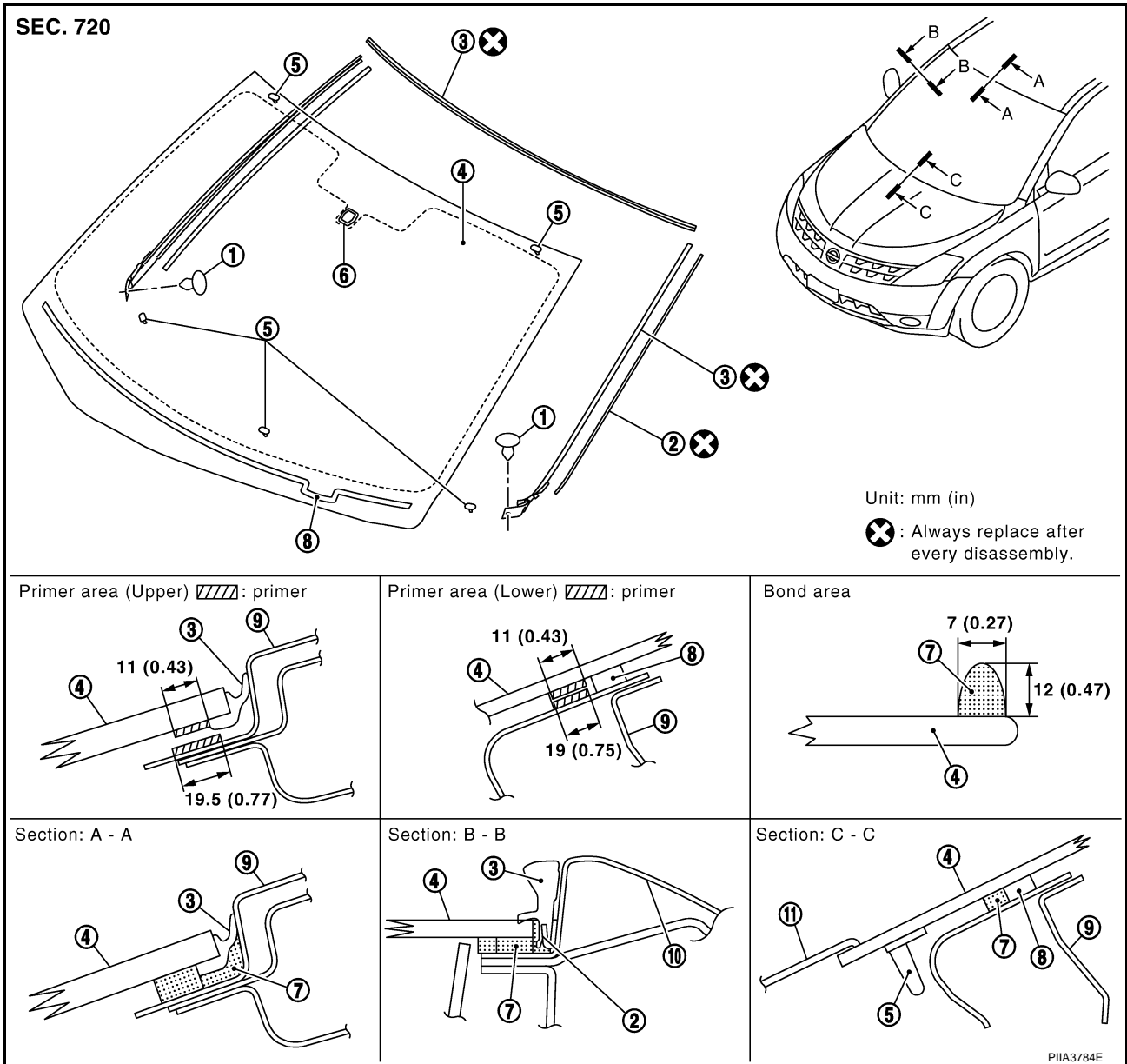

1. Clip (C103)
4. Windshield glass
7. Bond
10. Body side (outer)

2. Fastener
5. Spacer
8. Insulator
11. Cowl top cover

3. Molding
6. Mirror base
9. Panel

WINDSHIELD MOLDING

Removal

Remove windshield molding. Refer to [GW-11, "WINDSHIELD GLASS"](#) .

Installation

Install windshield molding. Refer to [GW-11, "WINDSHIELD GLASS"](#) .

SIDE WINDOW GLASS

PFP:83300

AIS005DK

SIDE WINDOW GLASS Removal and Installation

A
B
C
D
E
F
G
H
EI
J
K
L
M

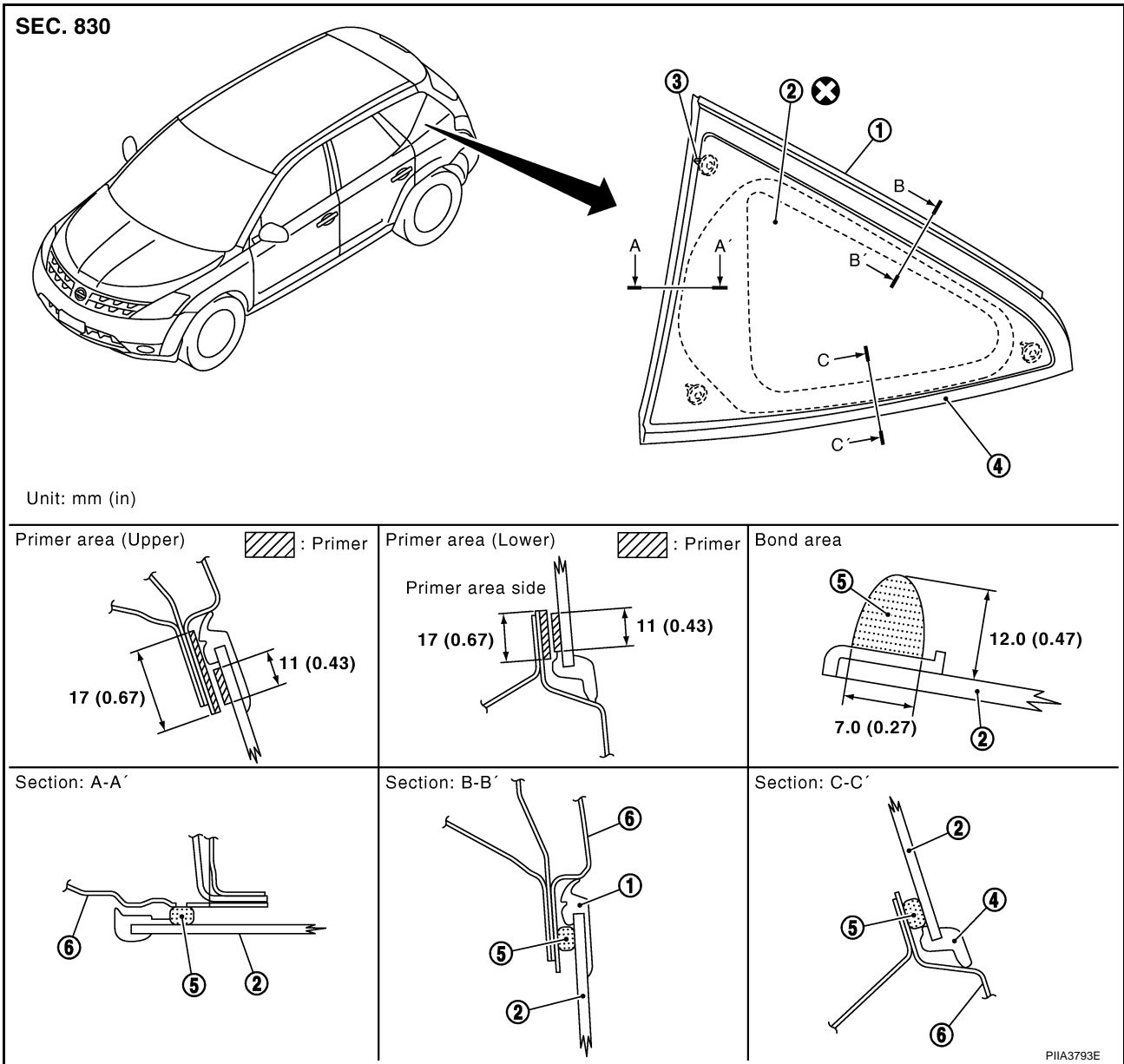

1. Side window glass molding (Upper)
2. Side window glass
3. Clip
4. Side window glass molding (Lower)
5. Bond
6. Body side outer panel

SIDE WINDOW MOLDING

Removal

Remove side window molding. Refer to [GW-15, "Removal and Installation"](#) .

Installation

Install side window molding. Refer to [GW-15, "Removal and Installation"](#) .

ROOF SIDE MOLDING

ROOF SIDE MOLDING

PFP:73854

Removal and Installation

AIS002AD

SEC. 730

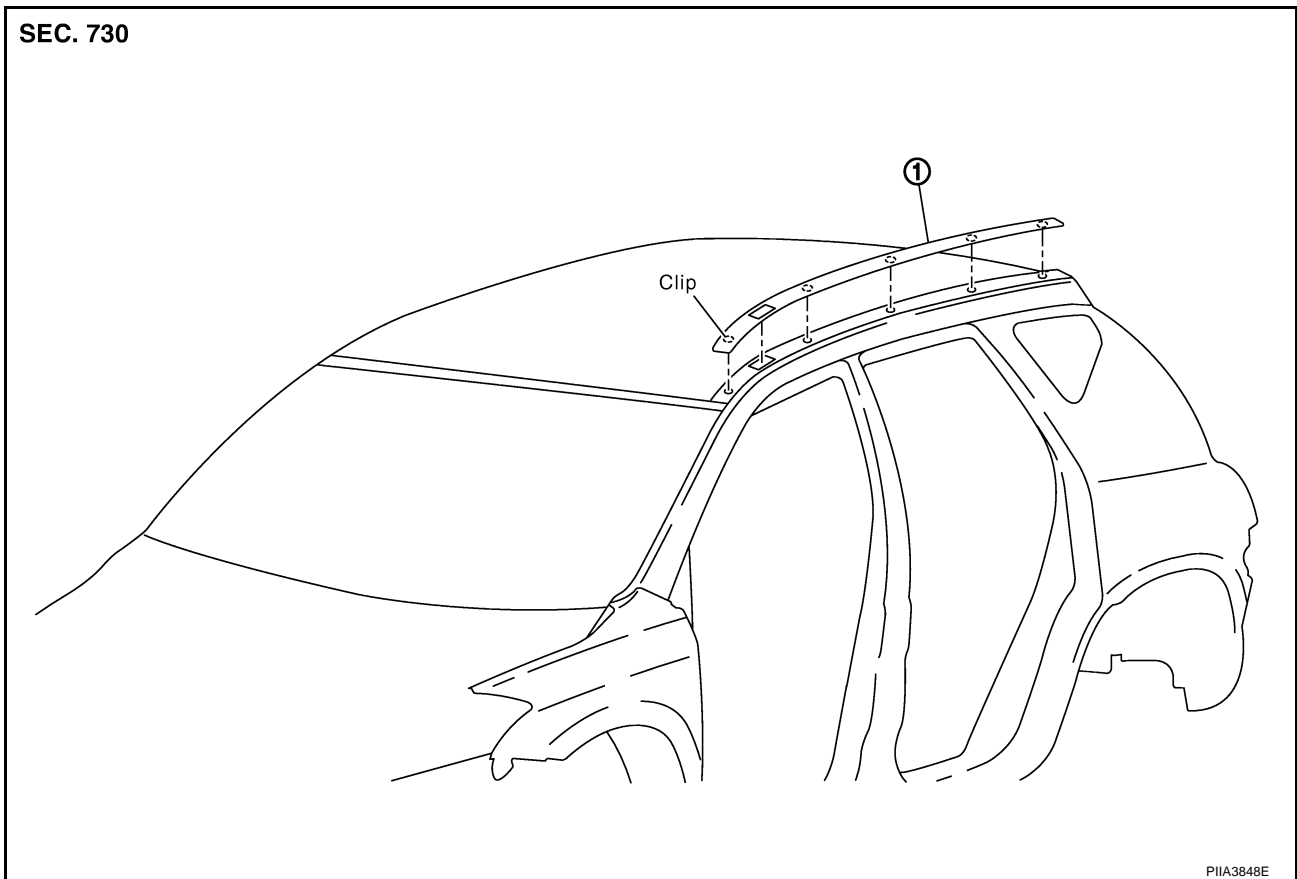

PIIA3848E

1. Roof side molding

REMOVAL

1. Disconnect molding clips from roof panel portion.
2. Remove roof side molding from the front side.

INSTALLATION

Install in the reverse order of removal.

CAUTION:

To install roof side molding, check if all clips are matched over holes of panel on vehicle, then push it.

ROOF RAIL

PFP:73820

ROOF RAIL

Removal and Installation

AIS002AE

A
B
C
D
E
F
G
H

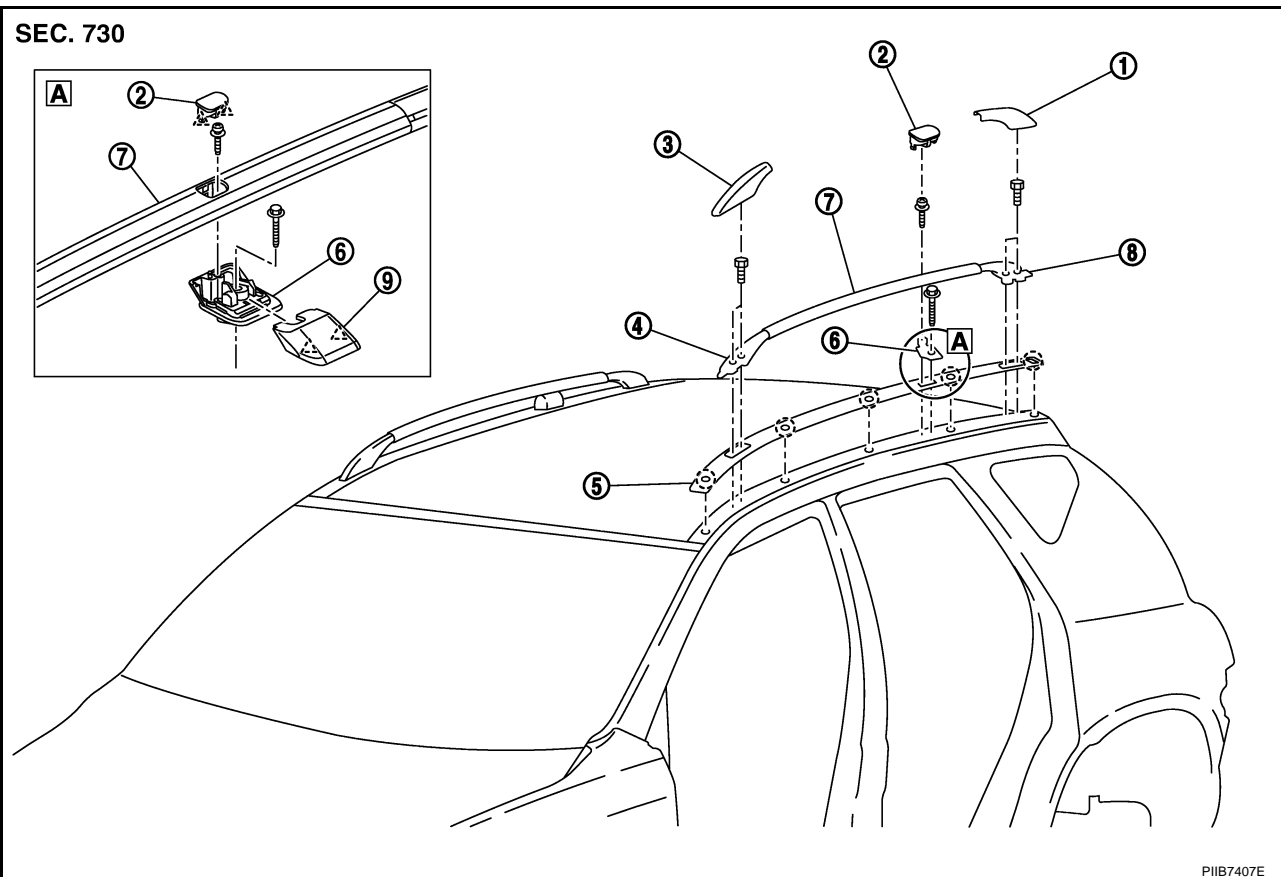

- | | | |
|-------------------------|-------------------------|---------------------------|
| 1. Roof rail rear cover | 2. Roof rail center cap | 3. Roof rail front cover |
| 4. Roof rail front leg | 5. Roof side molding | 6. Roof rail center leg |
| 7. Roof rail assembly | 8. Roof rail rear leg | 9. Roof rail center cover |
- Clip △ Pawl

EI

J
K
L
M

REMOVAL

1. Remove roof rail front cover and rear cover.
2. Remove roof rail center cap.
3. Remove roof rail front/rear leg bolts and remove roof rail center mounting bolt.
4. Remove roof rail assembly.
5. Remove roof rail center cover.
6. Remove roof rail center leg mounting bolt and remove roof center leg.
7. Remove roof side molding. Refer to [EI-28, "Removal and Installation"](#).

INSTALLATION

Install in the reverse order of removal.

CAUTION:

Match the position to location pin and assembly center leg and rail assembly.

DOOR FINISHER

DOOR FINISHER

PFP:80900

Removal and Installation

AIS002AF

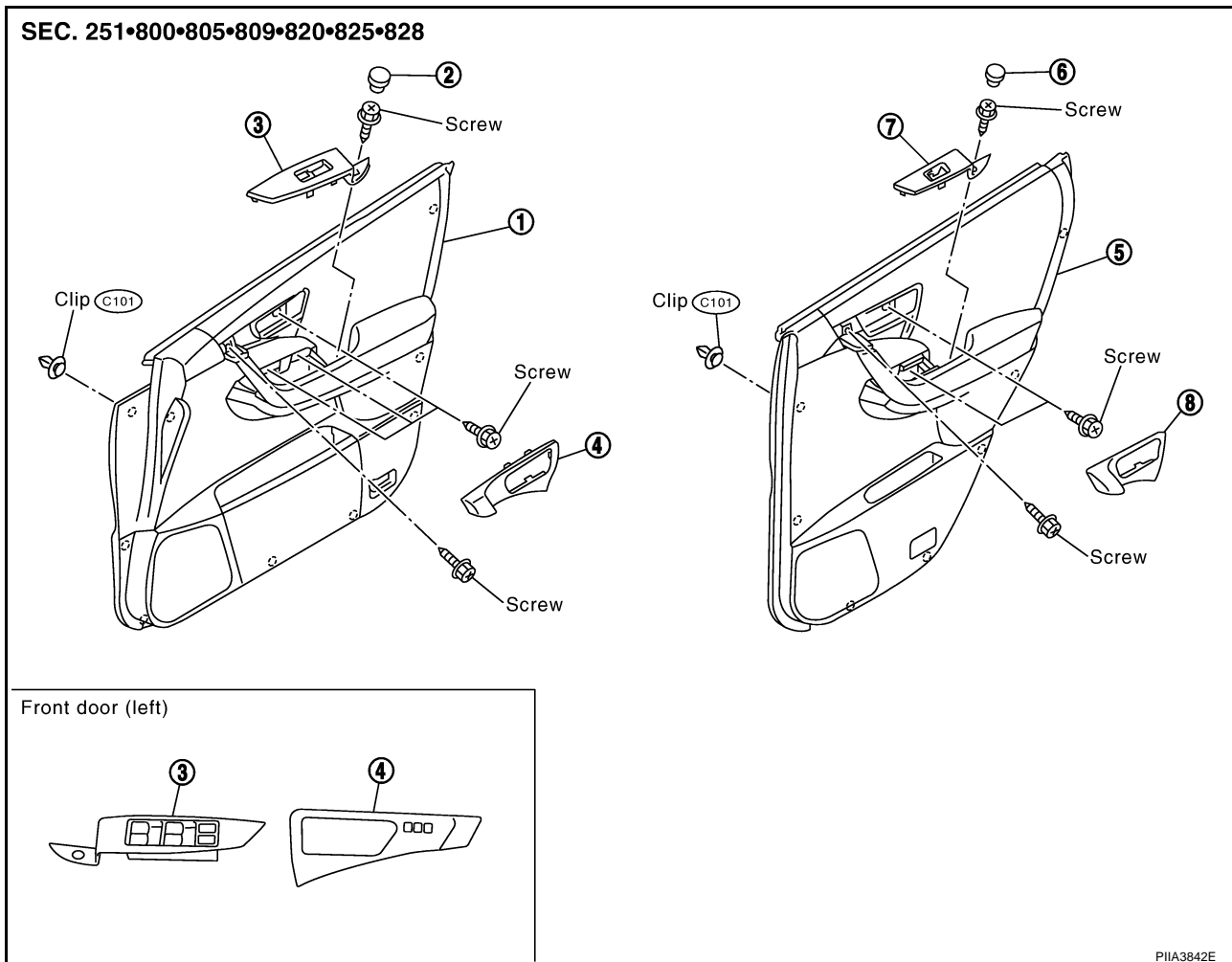

- | | | |
|--|------------------------------------|--|
| 1. Door finisher (front door) | 2. Cap (front door) | 3. Power window switch finisher (front right / left) |
| 4. Inside handle escutcheon (front right / left) | 5. Door finisher (rear door) | 6. Cap (rear door) |
| 7. Power window switch finisher (rear door) | 8. Inside handle escutcheon (rear) | |

DOOR FINISHER (FRONT AND REAR)

Removal

1. Remove cap of inside handle portion and remove screws.
2. Remove inside handle escutcheon.
3. Remove screw of grip portion.
4. Remove pull handle cap and remove screw.
5. Remove power window switch and disconnect harness connector of power window switch.
6. Remove screws of power window switch side portion.

DOOR FINISHER

7. Insert screw driver rolled with cloth between panel on vehicle and clips (as indicated with arrow), and remove finisher.

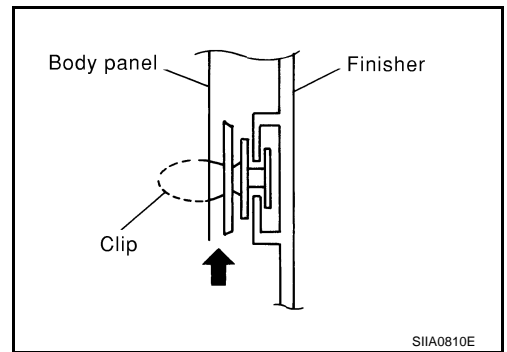

8. Pull up door finisher, and remove step lamp connector and electrical parts connectors.
9. Remove lock knob cable and inside handle cable of inside handle assembly back side.
10. Remove inside handle screws, and remove it from finisher.

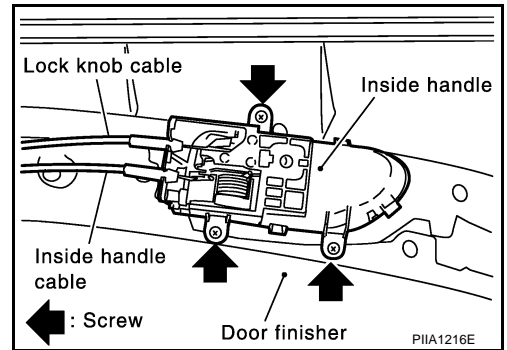

Installation

Install in the reverse order of removal.

CAUTION:

- To install finisher, check if all clips are matched over holes of panel on vehicle, then push it.
- Be careful at the time of install with the wound to door trim finisher.

BODY SIDE TRIM

BODY SIDE TRIM

PFP:76913

Removal and Installation

AIS002AG

CAUTION:

Wrap the tip of flat-bladed screwdriver with a cloth when removing metal clips from garnishes.

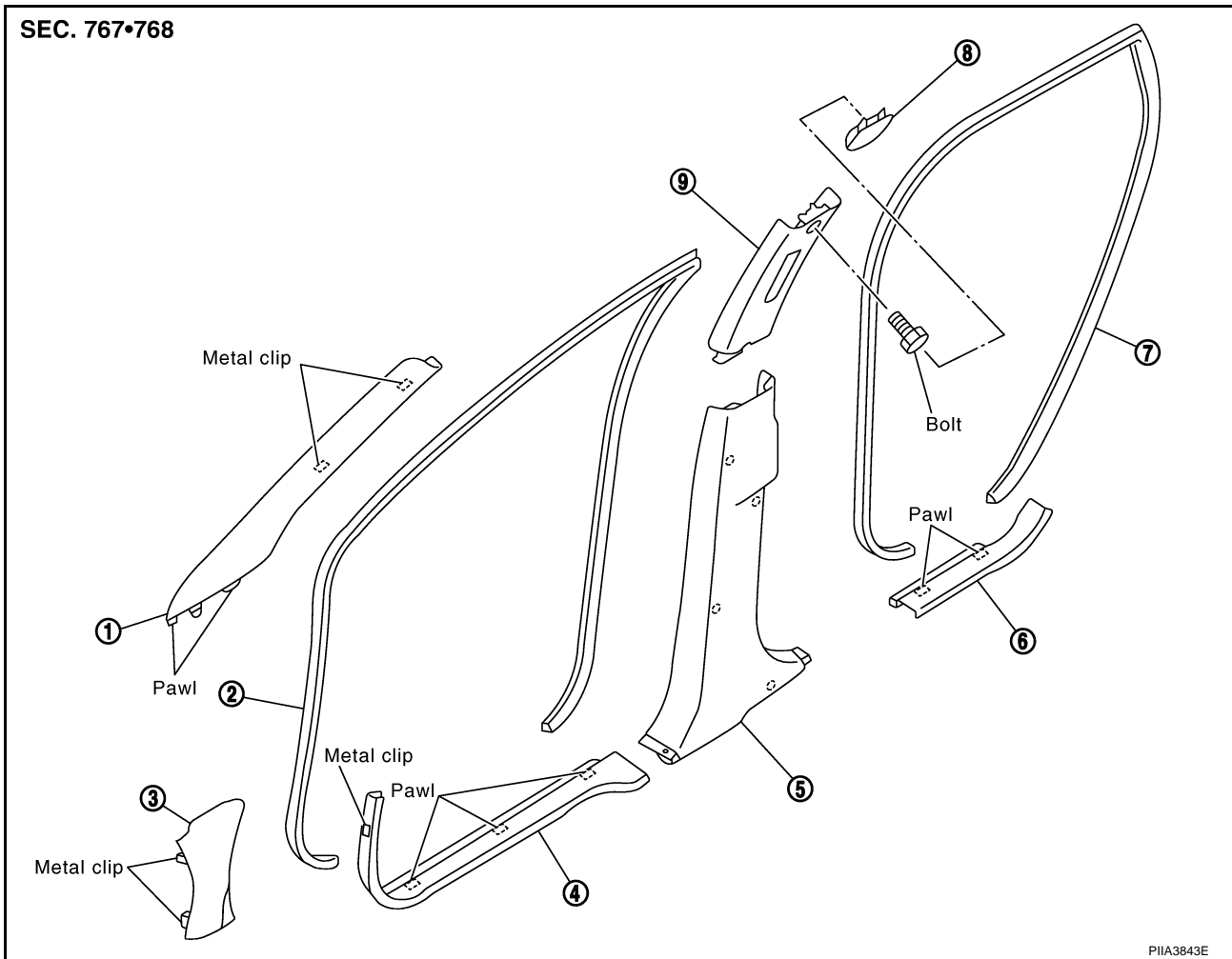

- | | | |
|-------------------------|--------------------------------|--------------------------------|
| 1. Front pillar garnish | 2. Front body side welt | 3. Dash side finisher |
| 4. Front kicking plate | 5. Center pillar lower garnish | 6. Rear kicking plate |
| 7. Rear body side welt | 8. Center pillar upper cap | 9. Center pillar upper garnish |

CENTER PILLAR LOWER GARNISH

Removal

1. Remove front and rear kicking plate.
2. Remove center pillar lower garnish.

Installation

Install in the reverse order of removal.

CENTER PILLAR UPPER GARNISH

Removal

1. Remove front seat belt shoulder anchor. Refer to [SB-3, "Removal and Installation of Front Seat Belt"](#).
2. Remove front and rear kicking plate.
3. Remove center pillar lower garnish.
4. Remove center pillar upper garnish.

BODY SIDE TRIM

Installation

Install in the reverse order of removal.

A

DASH SIDE FINISHER

Removal

1. Remove front kicking plate.
2. Remove front body side welt.
3. Remove dash side finisher.

B

NOTE:

Insert screw driver rolled with cloth between panel on vehicle and disconnect clips.

C

Installation

Install in the reverse order of removal.

D

NOTE:

To install, check if all clips are matched over holes of panel on vehicle, then push on.

E

FRONT PILLAR GARNISH

Removal

Remove front pillar garnish clips and remove front pillar garnish.

F

Installation

Install in the reverse order of removal.

G

FRONT AND REAR KICKING PLATE

Removal

Remove kicking plate clips and remove kicking plate.

H

Installation

Install in the reverse order of removal.

EI

FRONT AND REAR BODY SIDE WELT

Removal

Remove body side welt.

J

Installation

Install in the reverse order of removal.

K

L

M

FLOOR TRIM

FLOOR TRIM

PFP:74902

Removal and Installation

AIS002AH

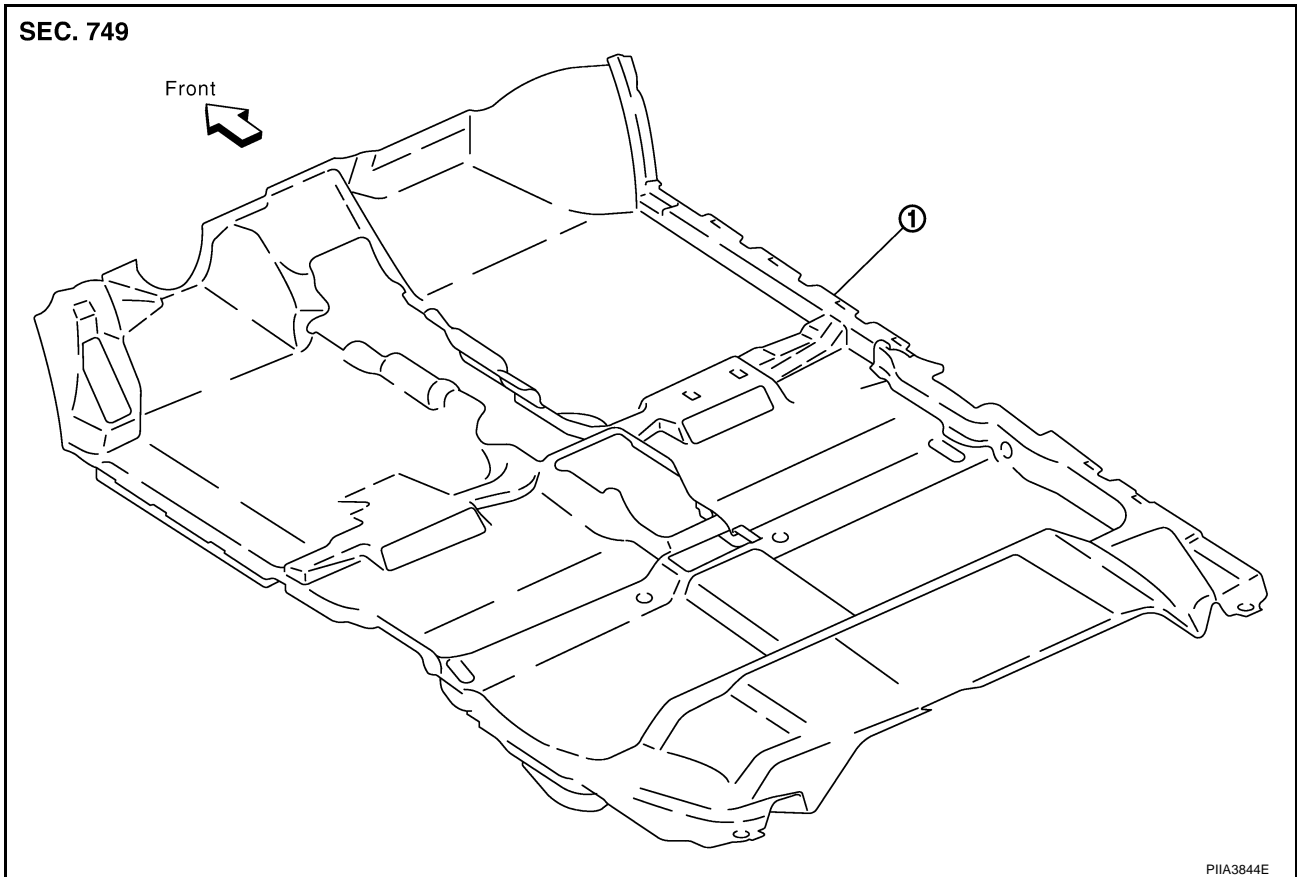

1. Floor carpet

REMOVAL

1. Remove front seat and rear seat cushion. Refer to [SE-104, "Removal and Installation"](#) and [SE-111, "Removal and Installation"](#) .
2. Remove center console upper and console lower. Refer to [IP-18, "Removal and Installation"](#) .
3. Remove seat belt anchor front and rear. Refer to [SB-3, "Removal and Installation of Front Seat Belt"](#) and [SB-5, "Removal and Installation of Rear Seat Belt"](#) .
4. Remove front and rear kicking plate. Refer to [EI-32, "Removal and Installation"](#) .
5. Remove front and rear body side welt. Refer to [EI-32, "Removal and Installation"](#) .
6. Remove center pillar lower garnish. Refer to [EI-32, "Removal and Installation"](#) .
7. Remove dash side finisher. Refer to [EI-32, "Removal and Installation"](#) .
8. Remove carpet hook.

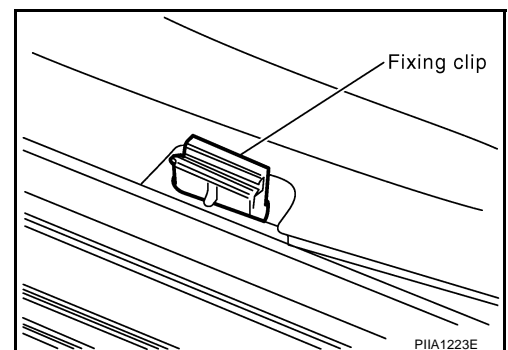

9. Remove floor carpet from carpet clip and remove floor carpet.

FLOOR TRIM

INSTALLATION

Install in the reverse order of removal.

A

B

C

D

E

F

G

H

EI

J

K

L

M

HEADLINING

PFP:73910

AIS002AI

HEADLINING

Removal and Installation

SEC. 264•738•963•964

Without sunroof

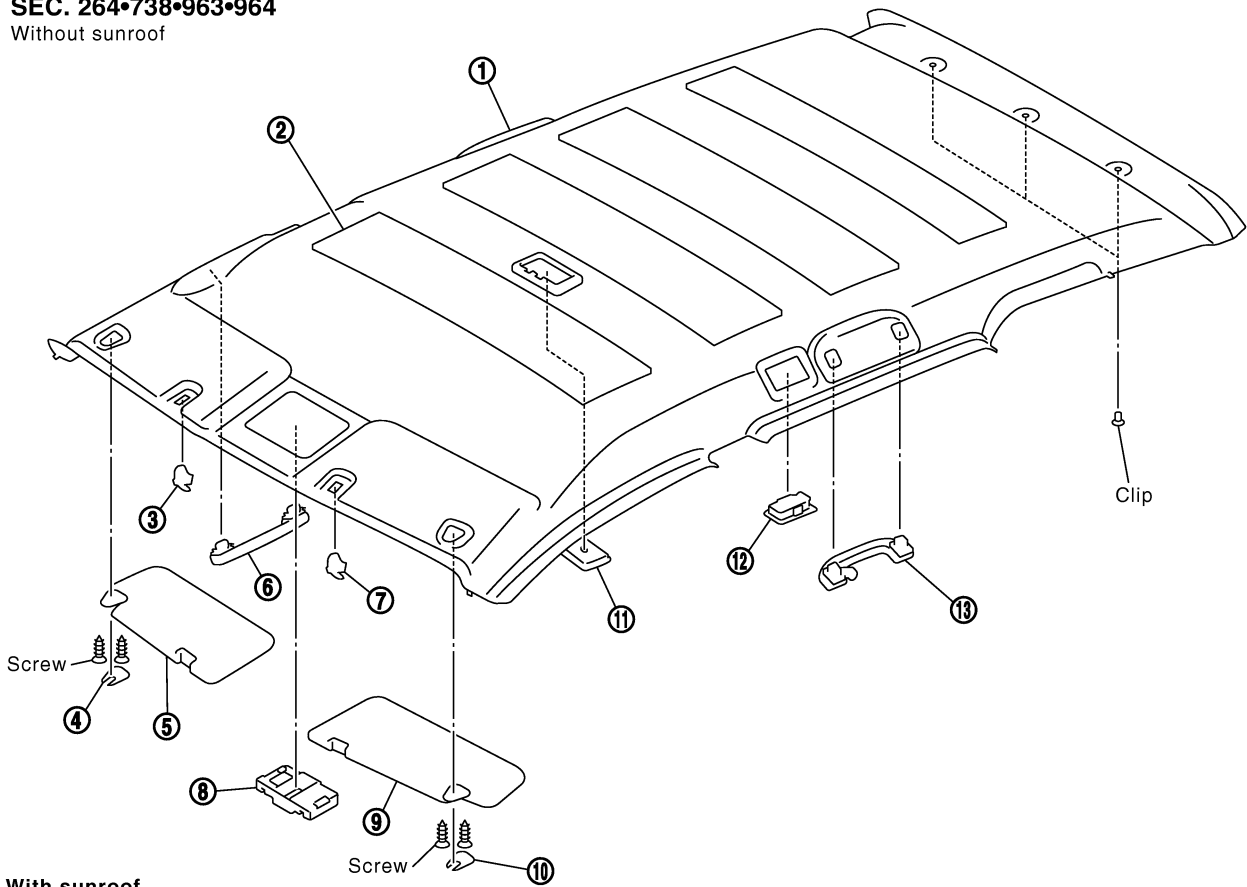

With sunroof

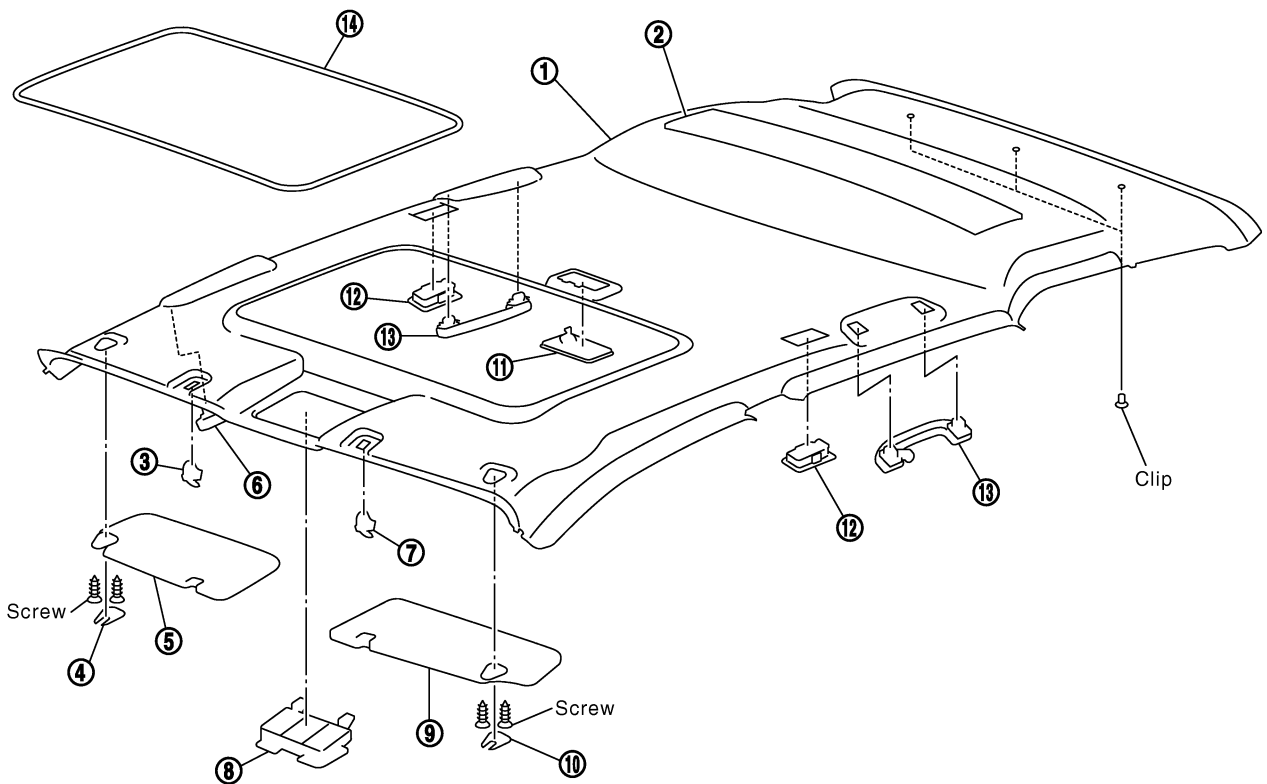

PIIA3845E

HEADLINING

- | | | |
|----------------------------|----------------------|-----------------------------|
| 1. Headlining | 2. Insulator | 3. Sun-visor holder (right) |
| 4. Sun-visor cover (right) | 5. Sun-visor (right) | 6. Assist grip (front) |
| 7. Sun-visor holder (left) | 8. Map lamp | 9. Sun-visor (left) |
| 10. Sun-visor cover (left) | 11. Room lamp | 12. Rear personal lamp |
| 13. Assist grip (rear) | 14. Sunroof welt | |

A
B

REMOVAL

1. Remove front pillar garnish, kicking plate (front/rear) and body side welt. Refer to [EI-32, "Removal and Installation"](#) .
2. Remove seat belt shoulder anchor (front/rear) and rear seat belt center shoulder anchor (upper). Refer to [SB-3, "Removal and Installation of Front Seat Belt"](#) and [SB-5, "Removal and Installation of Rear Seat Belt"](#) .
3. Remove center pillar garnish (lower/upper) and remove luggage side finisher (upper).
4. Remove assist grip.
Open covers both side and remove screws. (one each for left and right)

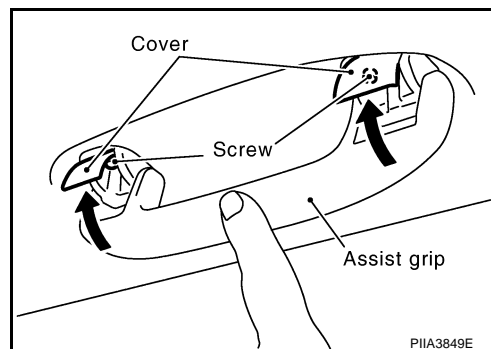

C
D
E
F
G
H

5. Remove sun-visor (driver and passenger), and disconnect harness connector.
6. Remove sun-visor holder.
7. Remove sunroof welt (with sunroof only).
8. Remove map lamp. Refer to [LT-172, "Removal and Installation"](#) .
9. Disconnect harness connector at back side of headlining.
10. Put front seat to front most and recline seat back to backward.
11. Remove clips of headlining.
12. Remove headlining, turn and take out from back door.

EI

CAUTION:

- Always remove or install in a pair.
- Cover surroundings with waste to avoid scratches or damages.
- Do not bend headlining too hard.

13. Remove following parts after removing headlining.
 - Room lamp
 - Rear personal lamp

J
K
L
M

INSTALLATION

Install in the reverse order of removal.

LUGGAGE FLOOR TRIM

PFP:84999

AIS002AJ

LUGGAGE FLOOR TRIM

Removal and Installation

SEC. 849

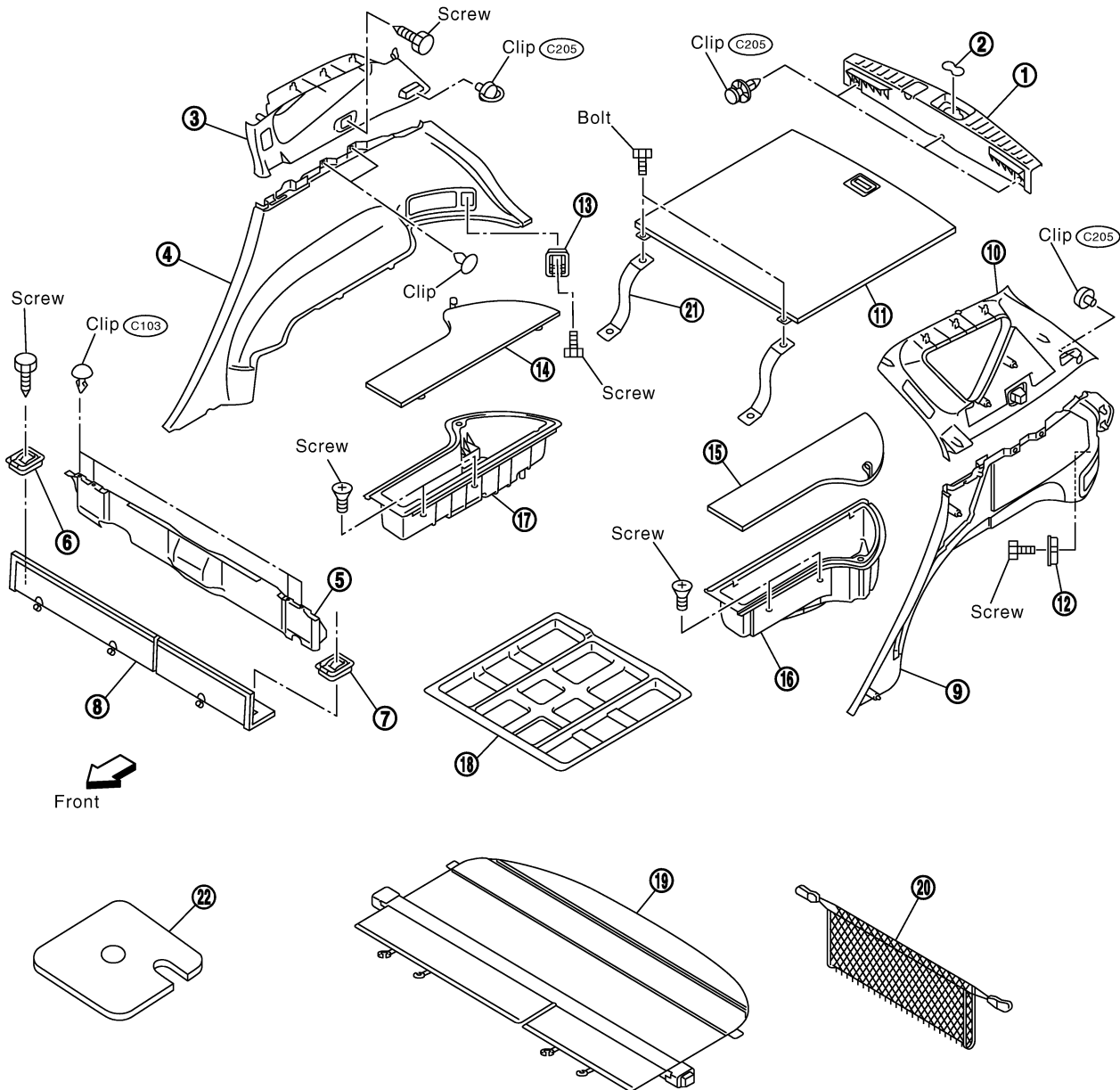

PIIA3846E

- | | | |
|--|-------------------------------------|--|
| 1. Rear plate | 2. Rear plate cap | 3. Luggage side finisher upper (right) |
| 4. Luggage side finisher lower (right) | 5. Luggage mask | 6. Front rope hook (right) |
| 7. Front rope hook (left) | 8. Luggage floor finisher (front) | 9. Luggage side finisher lower (left) |
| 10. Luggage side finisher upper (left) | 11. Luggage floor finisher (center) | 12. Rear rope hook (left) |

LUGGAGE FLOOR TRIM

-
- | | | |
|---------------------------------|------------------------------------|-----------------------------------|
| 13. Rear rope hook (right) | 14. Luggage floor finisher (right) | 15. Luggage floor finisher (left) |
| 16. Luggage floor spacer (left) | 17. Luggage floor spacer (right) | 18. Spare tire cover |
| 19. Tonneau cover | 20. Net | 21. Belt assembly |
| 22. Luggage floor cover | | |

A
B

REMOVAL

1. Remove rear seat belt anchor bolts (left/right). Refer to [SB-5, "Removal and Installation of Rear Seat Belt"](#).
2. Remove tonneau cover.
3. Remove clips (C205 net hook) and screws (left/right).
4. Remove luggage side finisher upper (left/right).
5. Remove rear plate.
6. Remove back door weatherstrip. Refer to [BL-183, "Removal and Installation of Back Door Weatherstrip"](#).
7. Remove luggage floor finisher center (left/right).
8. Remove rope hook of luggage floor finisher front and remove luggage floor finisher front.
9. Remove belt assembly and remove luggage floor finisher center.
10. Remove rope hook and remove rear seatback lever escutcheon (left/right).
11. Remove luggage side finisher lower (left/right).
12. Remove luggage floor spacer bolts and remove luggage floor spacer (left/right).
13. Remove spare tire cover.
14. Remove luggage mask.

C
D
E
F
G
H

INSTALLATION

Install in the reverse order of removal.

EI

J
K
L
M

BACK DOOR TRIM

PFP:90900

AIS002AK

BACK DOOR TRIM

Removal and Installation

REMOVAL

1. Open back door fully.
2. Remove pull handle.
3. Remove luggage room lamp, then disconnect luggage room lamp harness connectors. Refer to [LT-174, "LUGGAGE ROOM LAMP"](#) .
4. Remove clips, then remove back door finisher.
5. Remove high-mounted stop lamp cover.

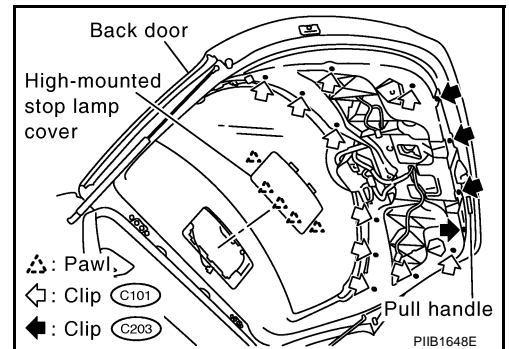

INSTALLATION

Install in the reverse order of removal.