

A  
B  
C  
D  
E  
F  
G  
H  
I  
J  
K

# DI

## SECTION

# DRIVER INFORMATION SYSTEM

## CONTENTS

<b>PRECAUTION</b> .....	<b>3</b>	Value or Varies .....	23
Precautions for Supplemental Restraint System (SRS) "AIR BAG" and "SEAT BELT PRE-TENSIONER" .....	3	Fuel Gauge Does Not Move to FULL Position .....	23
<b>COMBINATION METERS</b> .....	<b>4</b>	Electrical Components Inspection .....	25
System Description .....	4	FUEL LEVEL SENSOR UNIT CHECK .....	25
UNIFIED METER CONTROL UNIT .....	4	Removal and Installation of Combination Meter .....	25
UNIFIED METER AND A/C AMP. ....	4	REMOVAL .....	25
HOW TO CHANGE THE DISPLAY FOR ODO/TRIP METER .....	5	INSTALLATION .....	25
POWER SUPPLY AND GROUND CIRCUIT .....	6	Disassembly and Assembly of Combination Meter..	26
SPEEDOMETER .....	6	DISASSEMBLY .....	26
TACHOMETER .....	6	ASSEMBLY .....	27
WATER TEMPERATURE GAUGE .....	6	<b>UNIFIED METER AND A/C AMP</b> .....	<b>28</b>
FUEL GAUGE .....	6	System Description .....	28
Component Parts and Harness Connector Location...	7	INPUT/OUTPUT SIGNALS .....	28
Arrangement of Combination Meter .....	8	FAIL-SAFE .....	29
Circuit Diagram .....	9	CAN Communication System Description .....	29
Wiring Diagram — METER — .....	10	CAN Communication Unit .....	29
Terminals and Reference Value for Combination Meter .....	12	Schematic .....	30
Terminals and Reference Value for Unified Meter and A/C Amp. ....	13	CONSULT-II Function (METER A/C AMP) .....	31
Self-Diagnosis Mode of Combination Meter .....	14	CONSULT-II BASIC OPERATION .....	31
SELF-DIAGNOSIS FUNCTION .....	14	SELF-DIAGNOSTIC RESULTS .....	32
OPERATION PROCEDURE .....	14	DATA MONITOR .....	32
CONSULT-II Function (METER A/C AMP) .....	14	DTC [U1000] CAN Communication Circuit .....	34
Trouble Diagnosis .....	15	DTC [B2202] Meter Communication Circuit .....	34
HOW TO PERFORM TROUBLE DIAGNOSIS ...	15	DTC [B2205] Vehicle Speed Circuit .....	37
PRELIMINARY CHECK .....	15	Removal and Installation of Unified Meter and A/C Amp. ....	37
Symptom Chart 1 .....	16	REMOVAL .....	37
Symptom Chart 2 .....	16	INSTALLATION .....	37
Power Supply and Ground Circuit Inspection .....	17	<b>COMPASS</b> .....	<b>38</b>
Vehicle Speed Signal Inspection .....	19	System Description .....	38
Engine Speed Signal Inspection .....	20	DIRECTION DISPLAY .....	38
Engine Coolant Temperature Signal Inspection ....	20	Wiring Diagram — COMPASS — .....	40
Fuel Level Sensor Signal Inspection .....	21	Removal and Installation of Compass .....	41
Odo/Trip Meter and Illumination Control Switch Inspection .....	23	<b>WARNING LAMPS</b> .....	<b>42</b>
Fuel Gauge Pointer Fluctuates, Indicator Wrong		Schematic .....	42
		Wiring Diagram — WARN — .....	43
		Oil Pressure Warning Lamp Stays Off (Ignition Switch ON) .....	51
		Oil Pressure Warning Lamp Does Not Turn Off (Oil	

Pressure Is Normal) .....	52	Meter .....	69
Component Inspection .....	53	Trouble Diagnosis .....	69
OIL PRESSURE SWITCH .....	53	HOW TO PERFORM TROUBLE DIAGNOSIS ...	69
<b>CVT INDICATOR .....</b>	<b>54</b>	PRELIMINARY CHECK .....	69
Wiring Diagram — CVTIND — .....	54	CONSULT-II Function (BCM) .....	71
CVT Indicator Is Malfunction .....	58	DIAGNOSTIC ITEMS DESCRIPTION .....	71
<b>WARNING CHIME .....</b>	<b>60</b>	CONSULT-II BASIC OPERATION PROCEDURE	
System Description .....	60	...71	
FUNCTION .....	60	DATA MONITOR .....	72
IGNITION KEY WARNING CHIME (WITHOUT		ACTIVE TEST .....	72
INTELLIGENT KEY) .....	60	SELF-DIAGNOSTIC RESULTS .....	73
IGNITION KEY WARNING CHIME (WITH INTEL-		All Warnings Are Not Operated .....	73
LIGENT KEY) .....	61	Key Warning Chime and Light Warning Chime Does	
LIGHT WARNING CHIME .....	61	Not Operate (Seat Belt Warning Chime Does Oper-	
SEAT BELT WARNING CHIME .....	61	ate) .....	74
CAN Communication System Description .....	62	Key Warning Chime Does Not Operate (Without	
CAN Communication Unit .....	62	Intelligent Key) .....	75
Component Parts and Harness Connector Location..	62	Key Warning Chime Does Not Operate (With Intel-	
Schematic .....	63	ligent Key, When Mechanical Key Is Used) .....	77
Wiring Diagram — CHIME — .....	64	Key Warning Chime Does Not Operate (With Intel-	
Terminals and Reference Value for BCM .....	67	ligent Key, When Intelligent Key Is Carried With The	
Terminals and Reference Value for Unified Meter		Driver) .....	79
and A/C Amp. ....	68	Light Warning Chime Does Not Operate .....	79
Terminals and Reference Value for Combination		Seat Belt Warning Chime Does Not Operate .....	80

# PRECAUTION

## PRECAUTION

PPF:00011

### Precautions for Supplemental Restraint System (SRS) “AIR BAG” and “SEAT BELT PRE-TENSIONER”

AKS00D4N

The Supplemental Restraint System such as “AIR BAG” and “SEAT BELT PRE-TENSIONER”, used along with a front seat belt, helps to reduce the risk or severity of injury to the driver and front passenger for certain types of collision. This system includes seat belt switch inputs and dual stage front air bag modules. The SRS system uses the seat belt switches to determine the front air bag deployment, and may only deploy one front air bag, depending on the severity of a collision and whether the front occupants are belted or unbelted. Information necessary to service the system safely is included in the SRS and SB section of this Service Manual.

#### **WARNING:**

- To avoid rendering the SRS inoperative, which could increase the risk of personal injury or death in the event of a collision which would result in air bag inflation, all maintenance must be performed by an authorized NISSAN/INFINITI dealer.
- Improper maintenance, including incorrect removal and installation of the SRS, can lead to personal injury caused by unintentional activation of the system. For removal of Spiral Cable and Air Bag Module, see the SRS section.
- Do not use electrical test equipment on any circuit related to the SRS unless instructed to in this Service Manual. SRS wiring harnesses can be identified by yellow and/or orange harnesses or harness connectors.

A  
B  
C  
D  
E  
F  
G  
H  
I  
J  
DI  
L  
M

DI

# COMBINATION METERS

## COMBINATION METERS

PFP:24814

### System Description

AKS00D4P

#### UNIFIED METER CONTROL UNIT

- Speedometer, odo/trip meter, tachometer, fuel gauge and water temperature gauge are controlled by the unified meter control unit, which is built into the combination meter. Unified meter control unit receives signals from unified meter and A/C amp.
- Warning lamp and indicator lamp of combination meter are controlled by signals drawn from the unified meter and A/C amp.
- Digital meter is adopted for odo/trip meter.\*  
\*The record of the odo meter is kept even if the battery cable is disconnected. The record of the trip meter is erased when the battery cable is disconnected.
- Odo/trip meter and CVT indicator segments can be checked in diagnosis mode.
- Meters/gauges can be checked in diagnosis mode.

#### Illumination Control

The unified meter control unit outputs the odo/trip meter and CVT indicator lighting when the ignition switch is turned on. When the lighting switch is turned on, light on for the combination meter dial, odo/trip meter and illumination control switch and external lighting are output. In addition, when the lighting switch is turned on, the illumination control switch on the left side of the combination meter can be used to adjust the brightness of each light. The brightness can be adjusted to sixteen different levels: From 0 (no lights) to 15 (maximum). Pressing the illumination control switch will brighten or darken the lights. When the key switch is in the START position, the combination meter dial lighting and illumination control switch lighting are turned off.

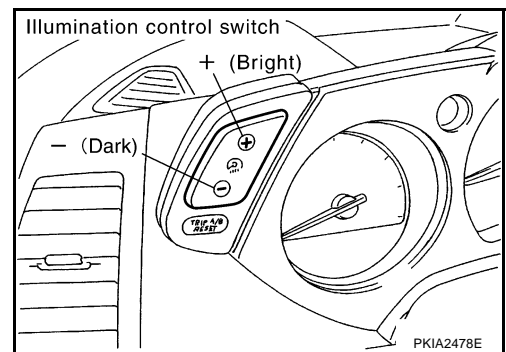

#### UNIFIED METER AND A/C AMP.

Refer to [DI-28. "System Description"](#) in "UNIFIED METER AND A/C AMP".

# COMBINATION METERS

## HOW TO CHANGE THE DISPLAY FOR ODO/TRIP METER

- The vehicle speed signal and the memory signals from the meter memory circuit are processed by the combination meter and the mileage is displayed.
- Depressing the odo/trip meter switch toggles the mode in the following order.

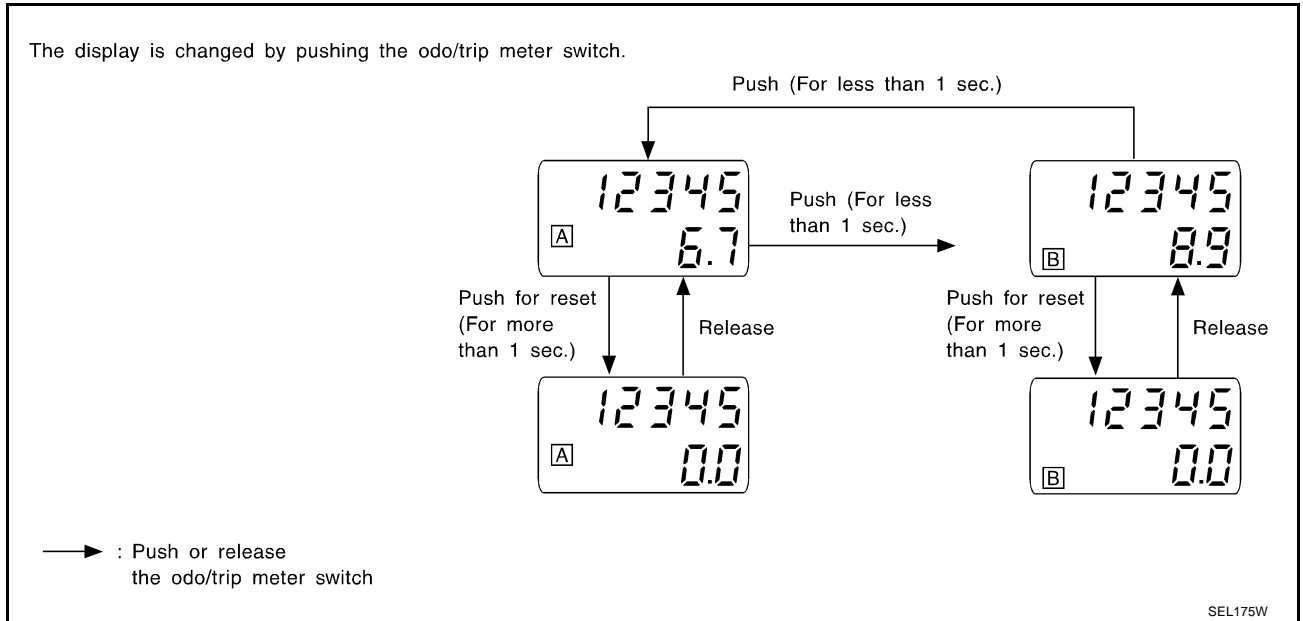

- The odo/trip meter display mode toggling and trip display resetting can be identified by the amount of time that elapses from pressing the odo/trip meter switch to releasing it.
- When resetting with trip A displayed, only trip A display is reset (Trip B operates the same way).

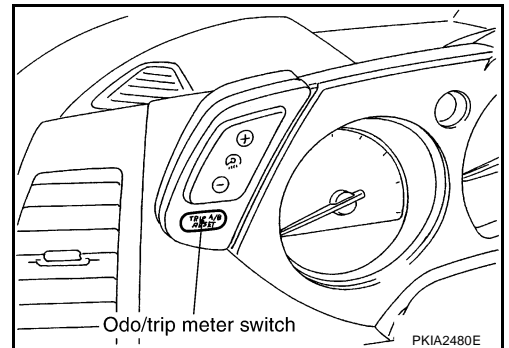

# COMBINATION METERS

---

## POWER SUPPLY AND GROUND CIRCUIT

Power is supplied at all times

- through 10A fuse [No. 19, located in the fuse block (J/B)]
- to unified meter and A/C amp. terminal 21,
- through 10A fuse [No. 21, located in the fuse block (J/B)]
- to combination meter terminal 21.

With the ignition switch in the ON or START position, power is supplied

- through 10A fuse [No. 14, located in the fuse block (J/B)]
- to combination meter terminal 20,
- through 10A fuse [No. 12, located in the fuse block (J/B)]
- to unified meter and A/C amp. terminal 22.

With the ignition switch in the ON position, power is supplied

- through 15A fuse [No. 10, located in the fuse block (J/B)], and
- through 15A fuse [No. 11, located in the fuse block (J/B)]
- to unified meter and A/C amp. terminal 46.

Ground is supplied

- to combination meter terminals 22, 23 and 24
- through grounds M14 and M78,
- to unified meter and A/C amp. terminals 29 and 30
- through grounds M14 and M78.

## SPEEDOMETER

ABS actuator and electric unit (control unit) provides a vehicle speed signal to the unified meter and A/C amp. with CAN communication line. After unified meter and A/C amp. received the vehicle speed signal, it changes the signal to 8 pulse signal and provides the 8 pulse signal to the combination meter for the speedometer.

## TACHOMETER

The tachometer indicates engine speed in revolutions per minute (rpm).

ECM provides an engine speed signal to unified meter and A/C amp. with CAN communication line. Unified meter and A/C amp. provides an engine speed signal to combination meter for tachometer with communication line between unified meter and A/C amp. and combination meter.

## WATER TEMPERATURE GAUGE

The water temperature gauge indicates the engine coolant temperature.

ECM provides a engine coolant temperature signal to unified meter and A/C amp. with CAN communication line. Unified meter and A/C amp. provides a water temperature signal to combination meter for water temperature gauge with communication line between unified meter and A/C amp. and combination meter.

## FUEL GAUGE

The fuel gauge indicates the approximate fuel level in the fuel tank.

The fuel gauge is regulated by a variable ground signal supplied

- from unified meter and A/C amp. terminal 36
- through the fuel level sensor unit and fuel pump (main) terminals 5 and 7
- through the fuel level sensor unit (sub), and
- through the fuel level sensor unit and fuel pump (main) terminals 6 and 2
- to unified meter and A/C amp. terminal 28 for the fuel gauge.

Unified meter and A/C amp. provides an fuel level signal to combination meter for fuel gauge with communication line between unified meter and A/C amp. and combination meter.

# COMBINATION METERS

## Component Parts and Harness Connector Location

AKS00D4Q

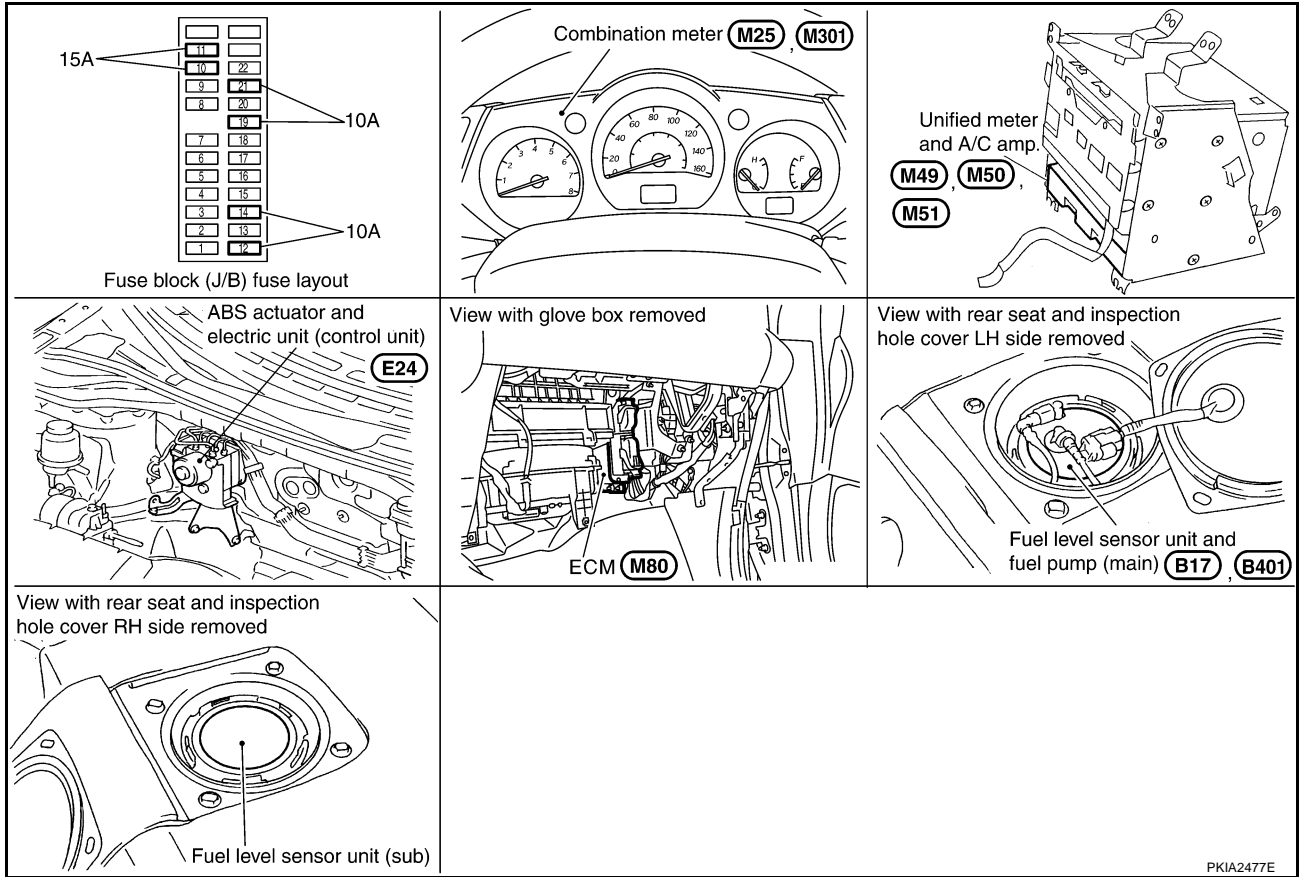

PKIA2477E

A  
B  
C  
D  
E  
F  
G  
H  
I  
J  
DI  
L  
M

# COMBINATION METERS

## Arrangement of Combination Meter

AKS00D4R

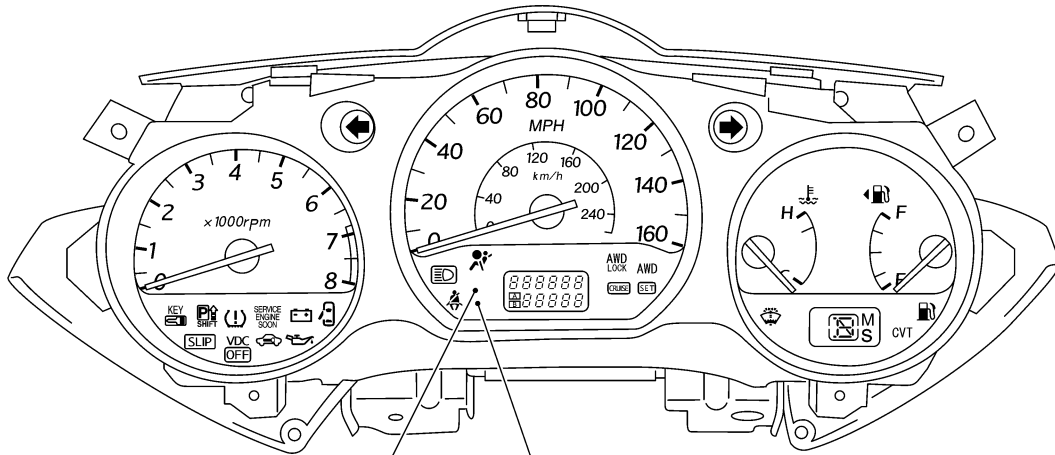

ABS : (U)      BRAKE : (U)  
 (ABS) : (C)      (!) : (C)

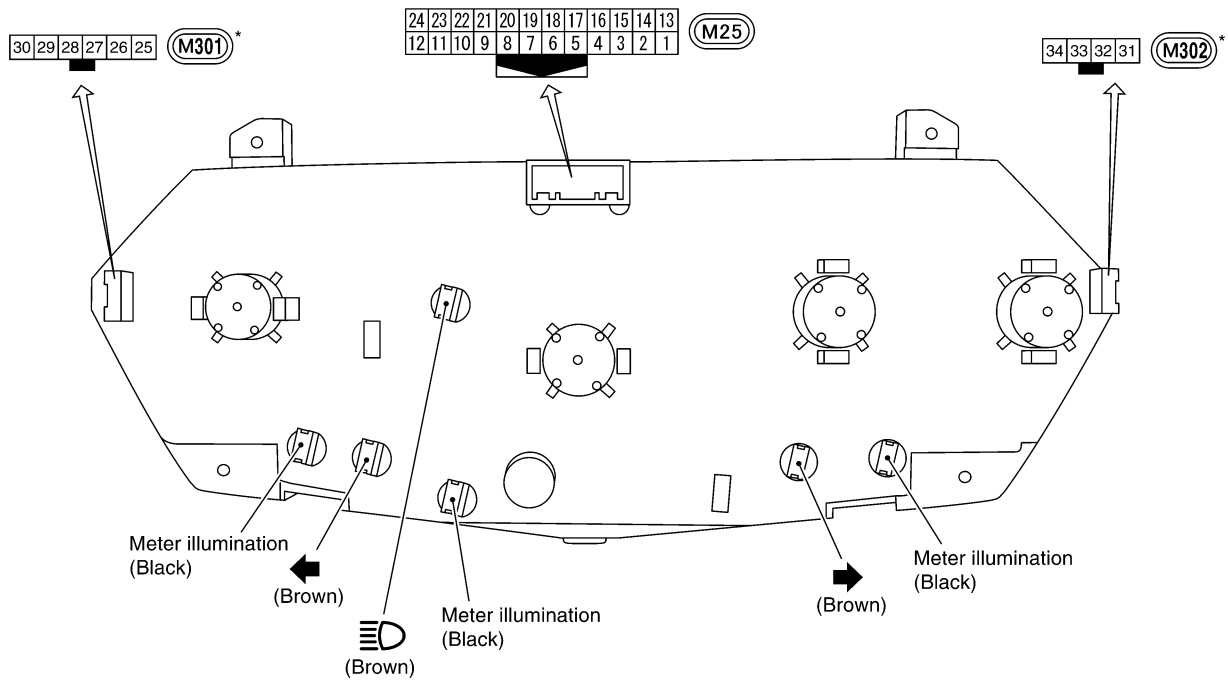

(U) : For U.S.A.

(C) : For Canada

Blub socket color	Bulb wattage
Brown	1.4W
Black	3.0W

( ) : Bulb socket color

\* THIS CONNECTOR IS NOT SHOW IN "HARNESS LAYOUT", PG SECTION.

PKIB4911E



# COMBINATION METERS

## Circuit Diagram

AKS00D4S

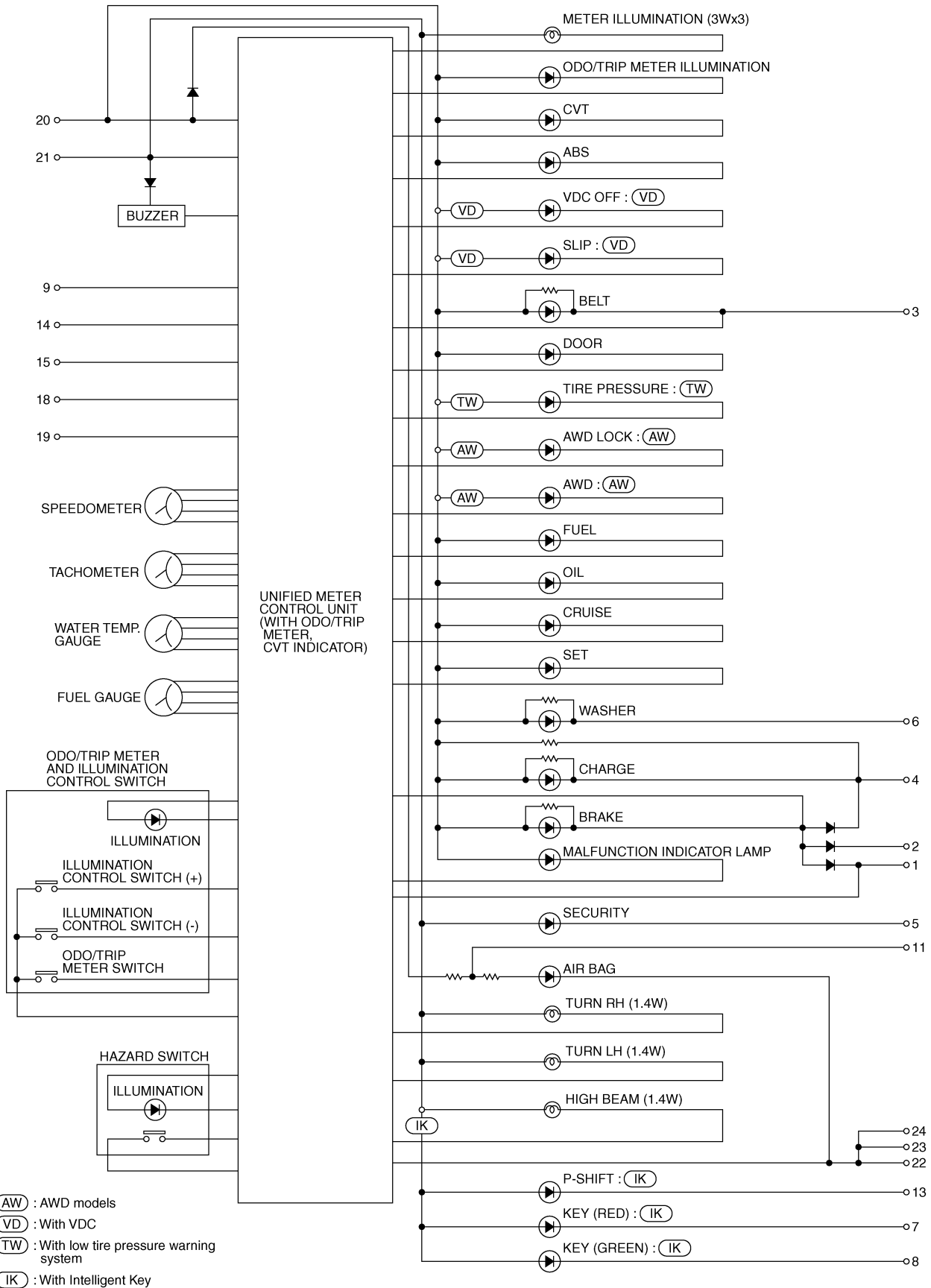

A  
B  
C  
D  
E  
F  
G  
H  
I  
J  
DI  
L  
M

# COMBINATION METERS

## Wiring Diagram — METER —

AKS00D4T

### DI-METER-01

▬▬▬ : DATA LINE

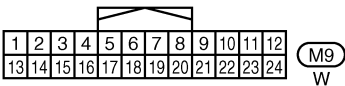
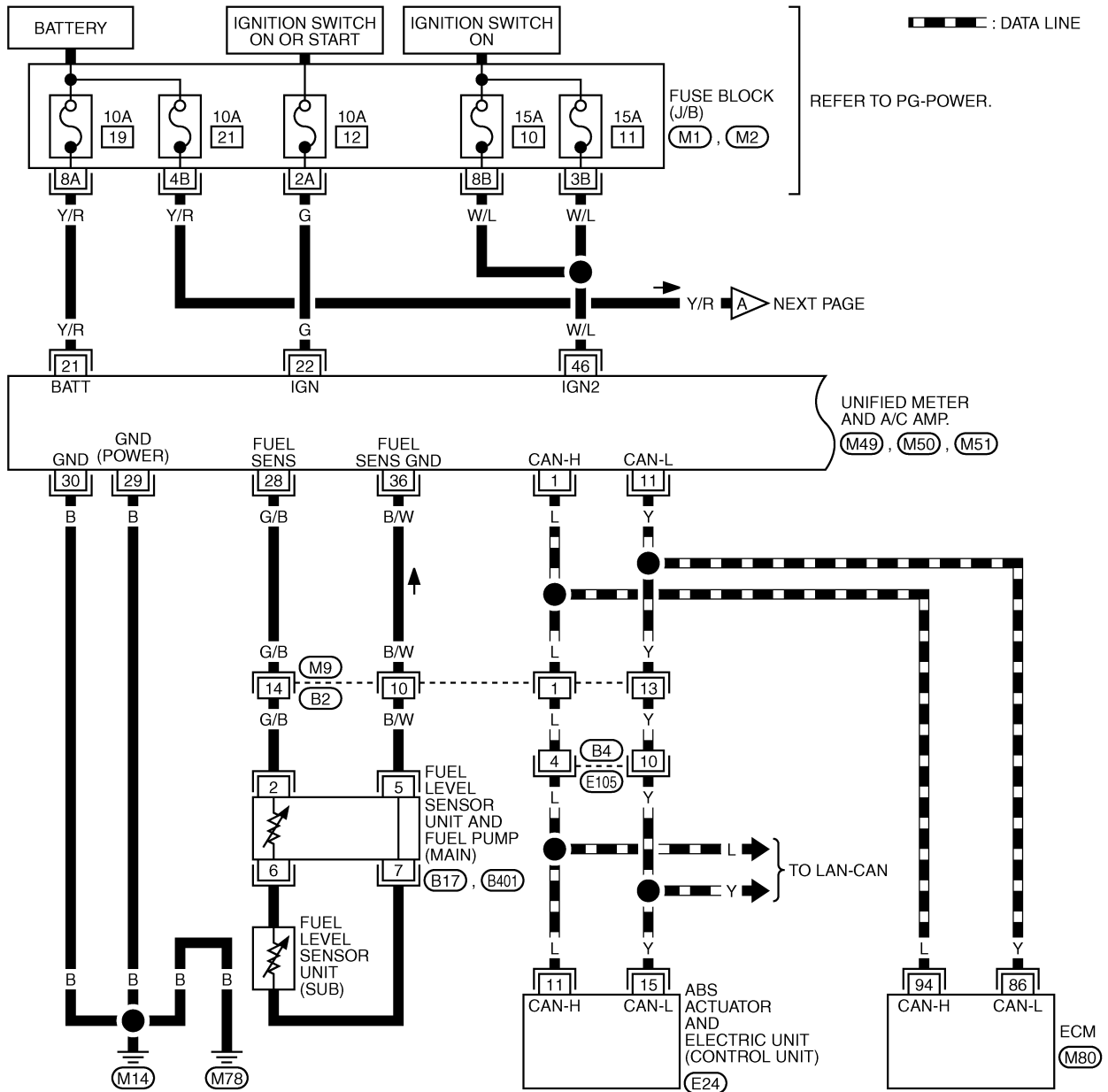

REFER TO THE FOLLOWING.  
 (M1), (M2) - FUSE BLOCK-JUNCTION BOX (J/B)  
 (M80), (E24) - ELECTRICAL UNITS

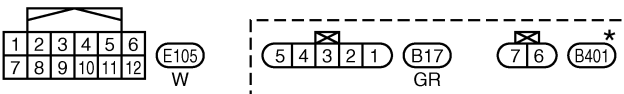
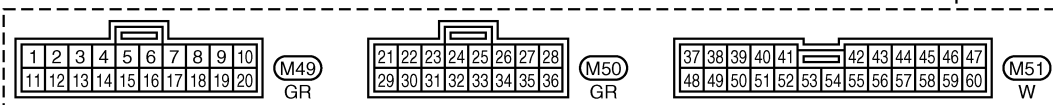

\*: THIS CONNECTOR IS NOT SHOWN IN "HARNESS LAYOUT", PG SECTION.

TKWB0481E

# COMBINATION METERS

DI-METER-02

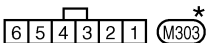
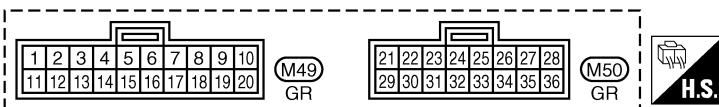
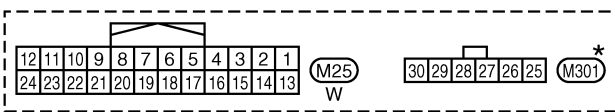
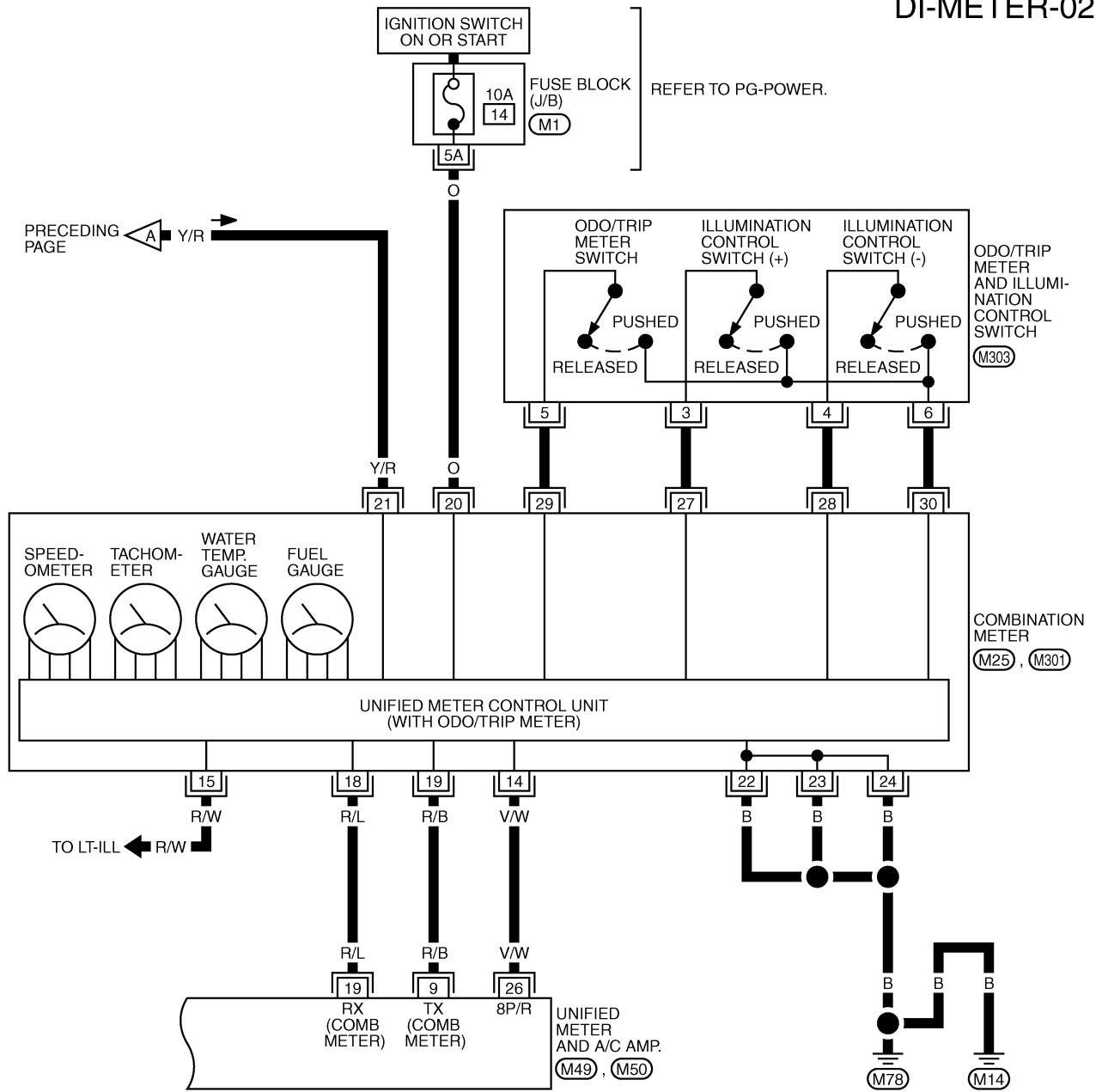

\*: THIS CONNECTOR IS NOT SHOWN IN "HARNES LAYOUT", PG SECTION.

REFER TO THE FOLLOWING.  
**(M1)** -FUSE BLOCK-JUNCTION BOX (J/B)

TKWB0902E

# COMBINATION METERS

## Terminals and Reference Value for Combination Meter

AKS00D4U

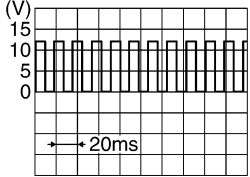
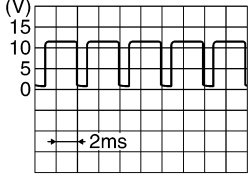
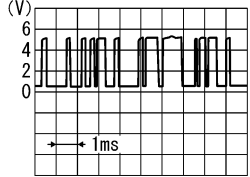
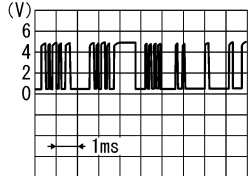
Terminal No.	Wire color	Item	Measuring condition		Reference value (V)
			Ignition switch	Operation or condition	
14	V/W	Vehicle speed signal (8-pulse)	ON	Speedometer operated [When vehicle speed is approx. 40 km/h (25 MPH)]	<p><b>NOTE:</b> Maximum voltage may be 5 V due to specifications (connected units).</p>  <p style="text-align: right;">PKIA1935E</p>
15	R/W	Illumination signal	ON	Lighting switch ON, then operate the illumination control switch.	<p>&lt;e.g.&gt; When brightness level is midway.</p>  <p style="text-align: right;">SKIA5872E</p>
				Lighting switch OFF	Approx. 0
18	R/L	TX communication line (To unified meter and A/C amp.)	ON	—	 <p style="text-align: right;">SKIA3361E</p>
19	R/B	RX communication line (From unified meter and A/C amp.)	ON	—	 <p style="text-align: right;">SKIA3362E</p>
20	O	Ignition switch ON or START	ON	—	Battery voltage
21	Y/R	Battery power supply	OFF	—	Battery voltage
22	B	Ground	ON	—	Approx. 0
23					
24					
27	—	Illumination control switch (+)	—	—	Refer to <a href="#">DI-23. "Odo/Trip Meter and Illumination Control Switch Inspection"</a> .
28		Illumination control switch (-)	—	—	
29		Odo/trip meter switch	—	—	
30		Odo/trip meter and illumination control switch ground	—	—	

# COMBINATION METERS

## Terminals and Reference Value for Unified Meter and A/C Amp.

AKS00D4V

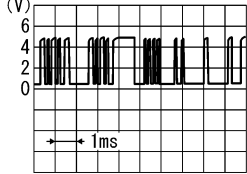
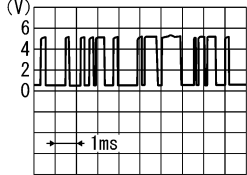
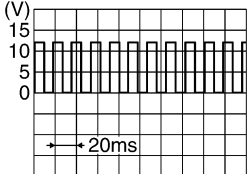
Terminal No.	Wire color	Item	Measuring condition		Reference value (V)
			Ignition switch	Operation or condition	
1	L	CAN H	—	—	—
9	R/B	TX communication line (To combination meter)	ON	—	
11	Y	CAN L	—	—	—
19	R/L	RX communication line (From combination meter)	ON	—	
21	Y/R	Battery power supply	OFF	—	Battery voltage
22	G	Ignition switch ON or START	ON	—	Battery voltage
26	V/W	Vehicle speed signal (8-pulse)	ON	Speedometer operated [When vehicle speed is approx. 40 km/h (25 MPH)]	<p><b>NOTE:</b> Maximum voltage may be 5 V due to specifications (connected units).</p> 
28	G/B	Fuel level sensor signal	—	—	Refer to <a href="#">DI-25. "FUEL LEVEL SENSOR UNIT CHECK"</a> .
29	B	Ground (For power)	ON	—	Approx. 0
30		Ground	ON	—	Approx. 0
36	B/W	Fuel level sensor signal ground	ON	—	Approx. 0
46	W/L	Ignition switch ON	ON	—	Battery voltage

A  
B  
C  
D  
E  
F  
G  
H  
I  
J  
DI  
L  
M

# COMBINATION METERS

## Self-Diagnosis Mode of Combination Meter SELF-DIAGNOSIS FUNCTION

AKS00D4W

- Odo/trip meter segment and CVT indicator segment operation can be checked in self-diagnosis mode.
- Meters/gauges can be checked in self-diagnosis mode.

### OPERATION PROCEDURE

1. Turn ignition switch ON, and switch the odo/trip meter to “trip A” or “trip B”.

#### NOTE:

If the diagnosis function is activated with the trip meter A displayed, the mileage on the trip meter A will indicate 0000.0 miles, but the actual trip mileage will be retained. (Trip B operates the same way.)

2. Turn ignition switch OFF.
3. While pushing the odo/trip meter switch, turn ignition switch ON again.
4. Make sure the trip meter displays “0000.0”.
5. Push the odo/trip meter switch at least 3 times. (Within 7 seconds after the ignition switch is turned ON.)

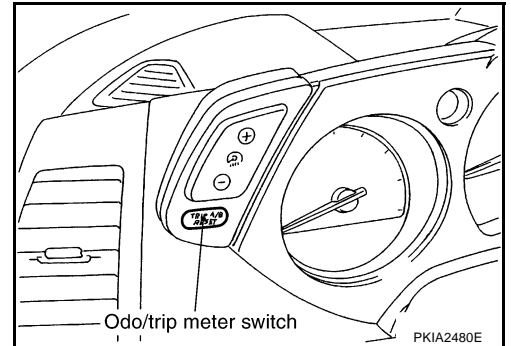

6. All the segments on the odo/trip meter and CVT indicator illuminate, and simultaneously the low-fuel warning lamp indicator illuminates. At this time, the unified meter control unit is turned to diagnosis mode.

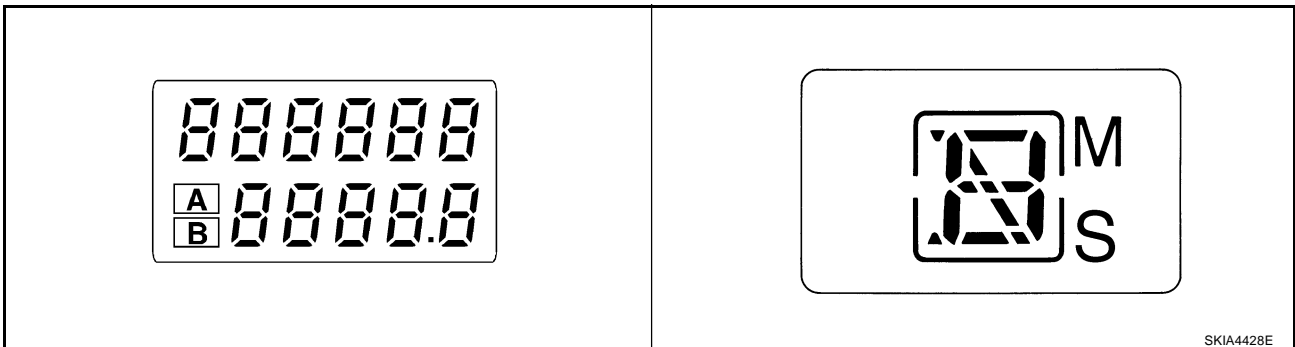

7. Push the odo/trip meter switch. Each meter/gauge should indicate as shown in the figure while pushing odo/trip meter switch. (At this time, the low-fuel warning lamp goes off.)

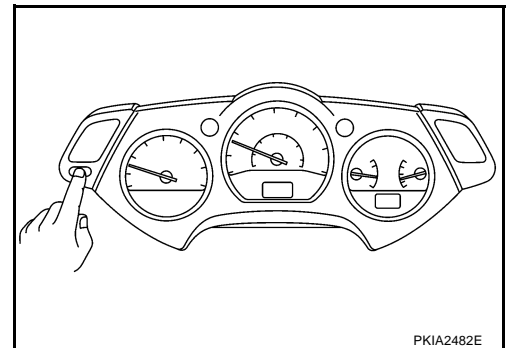

## CONSULT-II Function (METER A/C AMP)

AKS00D4X

Refer to [DI-31, "CONSULT-II Function \(METER A/C AMP\)"](#) in "UNIFIED METER AND A/C AMP".

# COMBINATION METERS

AKS00D4Y

## Trouble Diagnosis

### HOW TO PERFORM TROUBLE DIAGNOSIS

1. Confirm the symptom or customer complaint.
2. Perform diagnosis according to preliminary check. Refer to [DI-15, "PRELIMINARY CHECK"](#).
3. According to the symptom chart, repair or replace the cause of the symptom. Refer to [DI-16, "Symptom Chart 1"](#).
4. Does the meter operate normally? If so, GO TO 5. If not, GO TO 2.
5. INSPECTION END

### PRELIMINARY CHECK

#### 1. CHECK SELF-DIAGNOSTIC RESULTS OF UNIFIED METER AND A/C AMP.

Select "METER A/C AMP" on CONSULT-II, and perform self-diagnosis of unified meter and A/C amp. Refer to [DI-31, "CONSULT-II Function \(METER A/C AMP\)"](#).

Self-diagnostic results content

No malfunction detected>>GO TO 2.

Malfunction detected>> Go to [DI-16, "Symptom Chart 2"](#).

#### 2. CHECK WARNING LAMP ILLUMINATION

Turn ignition switch ON.

Do warning lamps (such as malfunction indicator lamp and oil pressure warning lamp) illuminate?

YES >> GO TO 3.

NO >> Check power supply circuit of combination meter when ignition switch is ON. Refer to [DI-17, "Power Supply and Ground Circuit Inspection"](#).

#### 3. CHECK SELF-DIAGNOSIS OPERATION OF COMBINATION METER

Perform combination meter self-diagnosis. Refer to [DI-14, "OPERATION PROCEDURE"](#).

Does self-diagnosis function operate?

YES >> GO TO 4.

NO >> Check the following.

- Battery power supply circuit and ground circuit of combination meter. Refer to [DI-17, "Power Supply and Ground Circuit Inspection"](#).
- Odo/trip meter switch. Refer to [DI-23, "Odo/Trip Meter and Illumination Control Switch Inspection"](#).

#### 4. CHECK ODO/TRIP METER OPERATION

Check segment display status of odo/trip meter.

Is the display normal?

YES >> GO TO 5.

NO >> Replace combination meter.

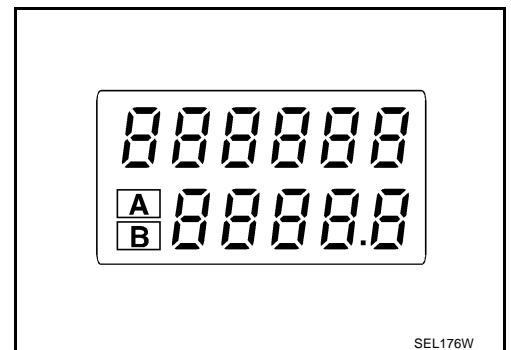

# COMBINATION METERS

## 5. CHECK LOW-FUEL WARNING LAMP ILLUMINATION CONFIRMATION

During low-fuel warning lamp check, confirm illumination of low-fuel warning lamp.

Condition of odo/trip meter switch	Low-fuel warning lamp
Pushed	Does not illuminate.
Released	Illuminates.

OK or NG

- OK >> GO TO 6.
- NG >> Replace combination meter.

## 6. CHECK COMBINATION METER CIRCUIT

Check indication of each meter/gauge in self-diagnosis mode.

OK or NG

- OK >> Go to [DI-16, "Symptom Chart 1"](#).
- NG >> Replace combination meter.

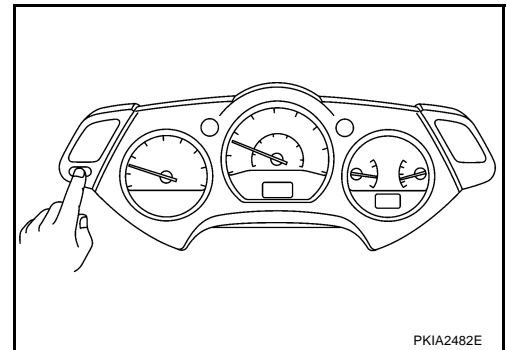

### Symptom Chart 1

AKS00D4Z

Trouble phenomenon	Possible cause
Indication is irregular for the speedometer and odo/trip meter.	Refer to <a href="#">DI-19, "Vehicle Speed Signal Inspection"</a> .
Tachometer indication is malfunction.	Refer to <a href="#">DI-20, "Engine Speed Signal Inspection"</a> .
Water temperature gauge indication is malfunction.	Refer to <a href="#">DI-20, "Engine Coolant Temperature Signal Inspection"</a> .
Fuel gauge indication is malfunction.	Refer to <a href="#">DI-21, "Fuel Level Sensor Signal Inspection"</a> .
Low-fuel warning lamp indication is irregular.	
CVT position indicator is malfunction.	Refer to <a href="#">DI-58, "CVT Indicator Is Malfunction"</a> .
Illumination control does not operate.	Refer to <a href="#">DI-23, "Odo/Trip Meter and Illumination Control Switch Inspection"</a> .

### Symptom Chart 2

AKS00D50

Displayed item [Code]	Inspection contents	Possible cause
CAN COMM CIRC [U1000]	Inspect the CAN communication.	Refer to <a href="#">DI-34, "DTC [U1000] CAN Communication Circuit"</a> . <b>CAUTION:</b> Even when there is no malfunction on CAN communication system, malfunction may be misinterpreted when battery has low voltage (when maintaining 7 - 8 V for about 2 seconds) or 10A fuse [No. 19, located in the fuse block (J/B)] fuse is disconnected.
METER COMM CIRC [B2202]	Inspect the communication line between combination meter and unified meter and A/C amp.	Refer to <a href="#">DI-34, "DTC [B2202] Meter Communication Circuit"</a> .
VEHICLE SPEED CIRC [B2205]	Inspect the vehicle speed input signal.	Refer to <a href="#">DI-37, "DTC [B2205] Vehicle Speed Circuit"</a> . <b>CAUTION:</b> Even when there is no malfunction on speed signal system, malfunction may be misinterpreted when battery has low voltage (when maintaining 7 - 8 V for about 2 seconds).



# COMBINATION METERS

## Power Supply and Ground Circuit Inspection

AKS00D51

### 1. CHECK FUSE

Check for blown combination meter and unified meter and A/C amp. fuses.

Unit	Power source	Fuse No.
Combination meter	Battery	21
Unified meter and A/C amp.	Battery	19
Combination meter	Ignition switch ON or START	14
Unified meter and A/C amp.	Ignition switch ON or START	12
	Ignition switch ON	10, 11

OK or NG

OK >> GO TO 2.

NG >> If fuse is blown, be sure to eliminate cause of malfunction before installing new fuse. Refer to [PG-3, "POWER SUPPLY ROUTING CIRCUIT"](#).

### 2. CHECK POWER SUPPLY CIRCUIT

- Check voltage between combination meter harness connector M25 terminals 20 (O), 21 (Y/R) and ground.

Terminals		Ignition switch position		
(+)		(-)	OFF	ON
Connector	Terminal (Wire color)		0 V	Battery voltage
M25	20 (O)	Ground	0 V	Battery voltage
	21 (Y/R)		Battery voltage	Battery voltage

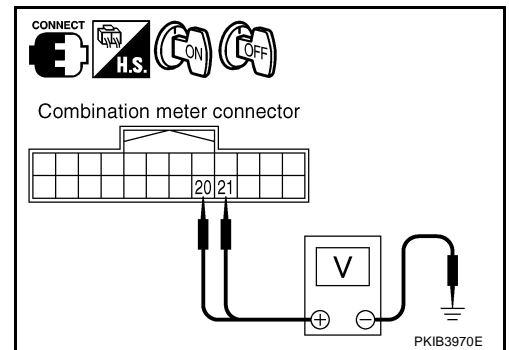

- Check voltage between unified meter and A/C amp. harness connector terminals and ground.

Terminals		Ignition switch position		
(+)		(-)	OFF	ON
Connector	Terminal (Wire color)		0 V	Battery voltage
M50	21 (Y/R)	Ground	Battery voltage	Battery voltage
	22 (G)		0 V	Battery voltage
M51	46 (W/L)		0 V	Battery voltage

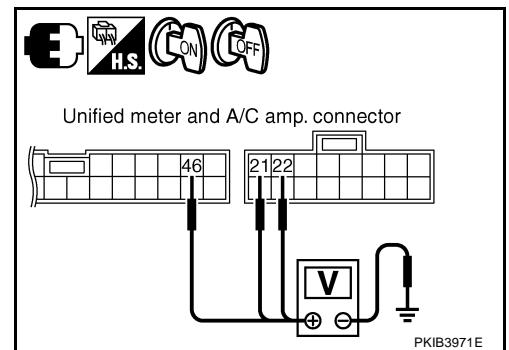

OK or NG

OK >> GO TO 3.

NG >> Check the following.

- Harness between combination meter and fuse
- Harness between unified meter and A/C amp. and fuse

# COMBINATION METERS

## 3. CHECK GROUND CIRCUIT

1. Turn ignition switch OFF.
2. Disconnect combination meter connector and unified meter and A/C amp. connector.
3. Check continuity between combination meter harness connector M25 terminals 22 (B), 23 (B), 24 (B) and ground.

**22 (B) – Ground**

**23 (B) – Ground**

**24 (B) – Ground**

**: Continuity should exist.**

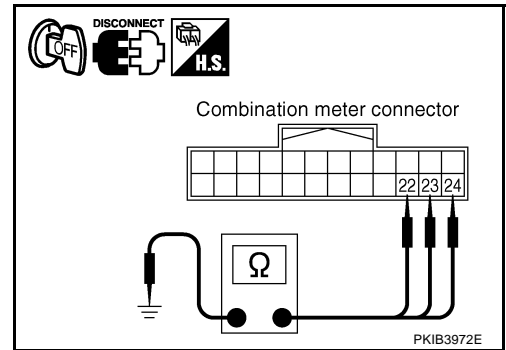

4. Check continuity between unified meter and A/C amp. harness connector M50 terminals 29 (B), 30 (B) and ground.

**29 (B) – Ground**

**30 (B) – Ground**

**: Continuity should exist.**

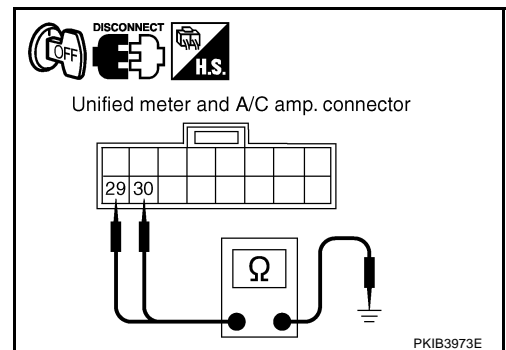

OK or NG

OK >> INSPECTION END

NG >> Repair harness or connector.

# COMBINATION METERS

AKS00D52

## Vehicle Speed Signal Inspection

Symptom: Indication is irregular for the speedometer and odo/trip meter.

### 1. CHECK ABS ACTUATOR AND ELECTRIC UNIT (CONTROL UNIT) SELF-DIAGNOSIS

Perform the ABS actuator and electric unit (control unit) self-diagnosis. Refer to [BRC-70, "CONSULT-II Functions"](#) (with VDC system) or [BRC-20, "CONSULT- II Functions"](#) (without VDC system).

#### Self-diagnostic results content

No malfunction detected >>GO TO 2.

Malfunction detected >>Check applicable parts, and repair or replace corresponding parts.

### 2. CHECK UNIFIED METER AND A/C AMP. OUTPUT SIGNAL

1. Start engine and drive vehicle at approximately 40 km/h (25 MPH).
2. Check voltage signal between unified meter and A/C amp. harness connector M50 terminal 26 (V/W) and ground.

**NOTE:**  
Maximum voltage may be 5 V due to specifications (connected units).

26 (V/W) – Ground:

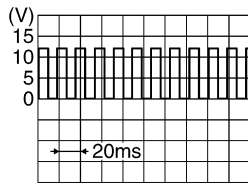

PKIA1935E

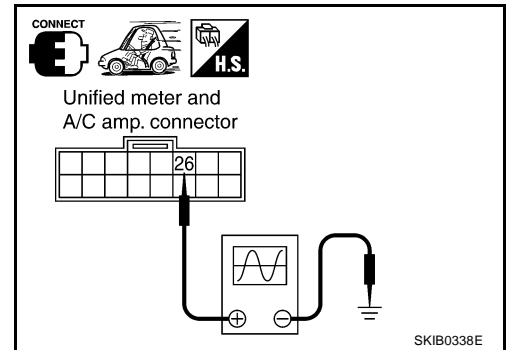

#### OK or NG

OK >> GO TO 3.

NG >> ● If monitor indicates "0 V" constantly, repair or replace malfunctioning parts after checking each unit inputting vehicle speed signal (8 pulse), harness and connector between each unit and unified meter and A/C amp.

- If monitor indicates "5 V" or "12 V" constantly, replace unified meter and A/C amp. Refer to [DI-37, "Removal and Installation of Unified Meter and A/C Amp."](#)

### 3. CHECK CONTINUITY BETWEEN COMBINATION METER AND UNIFIED METER AND A/C AMP.

1. Turn ignition switch OFF.
2. Disconnect combination meter connector and unified meter and A/C amp. connector.
3. Check continuity between combination meter harness connector M25 terminal 14 (V/W) and unified meter and A/C amp. harness connector M50 terminal 26 (V/W).

14 (V/W) – 26 (V/W) : Continuity should exist.

#### OK or NG

OK >> Replace combination meter.

NG >> Repair harness or connector.

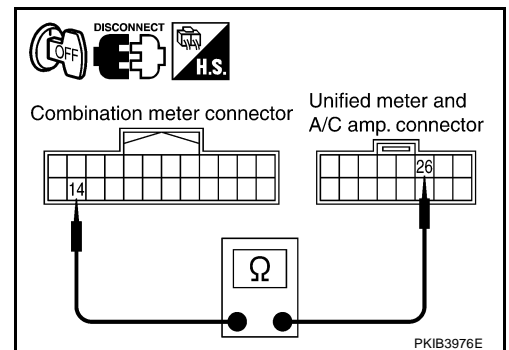

# COMBINATION METERS

## Engine Speed Signal Inspection

AKS00D53

Symptom: Tachometer indication is malfunction.

### 1. CHECK UNIFIED METER AND A/C AMP. OUTPUT SIGNAL

1. Start engine and select "METER A/C AMP" on CONSULT-II.
2. Using "TACHO METER" on "DATA MONITOR", compare the value of "DATA MONITOR" with tachometer pointer of combination meter.

OK or NG

- OK >> GO TO 2.  
 NG >> Replace combination meter.

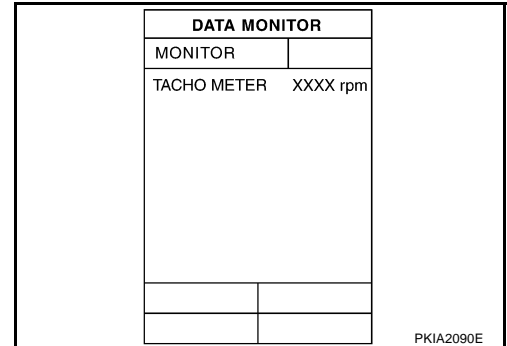

### 2. CHECK UNIFIED METER AND A/C AMP. INPUT SIGNAL

1. Select "ENGINE" on CONSULT-II.
2. Using "ENG SPEED" on "DATA MONITOR", print out the CONSULT-II screen when the engine is idling.
3. Select "METER A/C AMP" on CONSULT-II.
4. Using "TACHO METER" on "DATA MONITOR", compare the value of "DATA MONITOR" of the idling speed with that of the "ENG SPEED".

OK or NG

- OK >> Perform ECM self-diagnosis. Refer to [EC-126, "CONSULT-II Function \(ENGINE\)"](#).
- NG >> Replace unified meter and A/C amp. Refer to [DI-37, "Removal and Installation of Unified Meter and A/C Amp."](#)

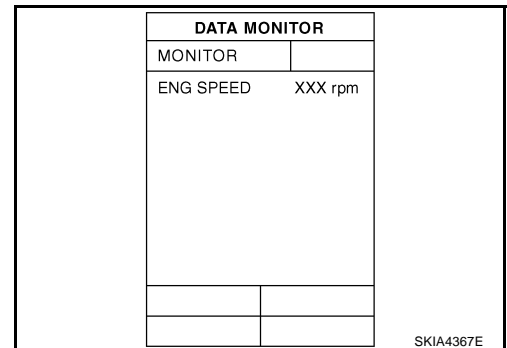

## Engine Coolant Temperature Signal Inspection

AKS00D54

Symptom: Water temperature gauge indication is malfunction.

### 1. CHECK UNIFIED METER AND A/C AMP. OUTPUT SIGNAL

1. Start engine and select "METER A/C AMP" on CONSULT-II.
2. Using "W TEMP METER" on "DATA MONITOR", compare the value of "DATA MONITOR" with water temperature gauge pointer of combination meter.

Water temperature gauge pointer	Reference value of data monitor [°C (°F)]
Hot	Approx. 130 (266)
Middle	Approx. 70 - 105 (158 - 221)
Cold	Approx. 50 (122)

OK or NG

- OK >> GO TO 2.  
 NG >> Replace combination meter.

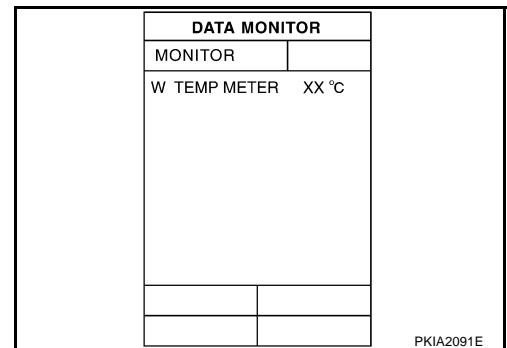

# COMBINATION METERS

## 2. CHECK UNIFIED METER AND A/C AMP. INPUT SIGNAL

1. Select "ENGINE" on CONSULT-II.
2. Using "COOLAN TEMP/S" on "DATA MONITOR", print out the CONSULT-II screen.
3. Select "METER A/C AMP" on CONSULT-II.
4. Using "W TEMP METER" on "DATA MONITOR", compare the value of data monitor with that of the "COOLAN TEMP/S".

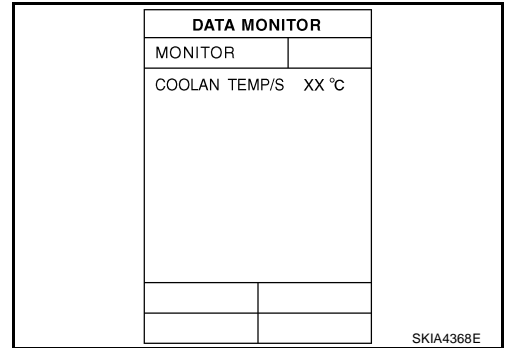

### OK or NG

- OK >> Perform ECM self-diagnosis. Refer to [EC-126, "CONSULT-II Function \(ENGINE\)"](#).
- NG >> Replace unified meter and A/C amp. Refer to [DI-37, "Removal and Installation of Unified Meter and A/C Amp."](#)

## Fuel Level Sensor Signal Inspection

AKS00D55

### Symptom:

- Fuel gauge indication is malfunction.
- Low-fuel warning lamp indication is irregular.

### NOTE:

The following symptoms are not malfunction.

#### Fuel level sensor unit

- Depending on vehicle position or driving circumstance, the fuel level in the tank varies, and the pointer may fluctuate.
- If the vehicle is fueled with the ignition switch ON, the pointer will move slowly.

#### Low-fuel warning lamp

- Depending on vehicle position or driving circumstance, the fuel in the tank flows and the warning lamp ON timing may change.

## 1. CHECK UNIFIED METER AND A/C AMP. INPUT SIGNAL

1. Select "METER A/C AMP" on CONSULT-II.
2. Using "FUEL METER" on "DATA MONITOR", compare the value of "DATA MONITOR" with fuel gauge pointer of combination meter.

Fuel gauge pointer	Reference value of data monitor [lit.]
Full	Approx. 78
Three quarters	Approx. 63
Half	Approx. 43
A quarter	Approx. 22
Empty	Approx. 7

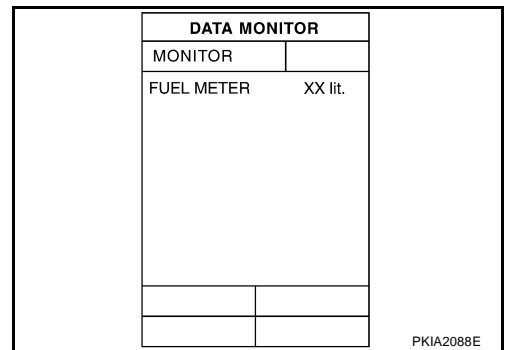

### OK or NG

- OK >> GO TO 2.
- NG >> Replace combination meter.

## 2. CHECK FUEL LEVEL SENSOR

Check components. Refer to [DI-25, "FUEL LEVEL SENSOR UNIT CHECK"](#).

### OK or NG

- OK >> GO TO 3.
- NG >> Replace fuel level sensor unit.

# COMBINATION METERS

## 3. CHECK FUEL LEVEL SENSOR (MAIN) CIRCUIT 1

1. Disconnect fuel level sensor unit and fuel pump (main) connector and unified meter and A/C amp. connector.
2. Check continuity between fuel level sensor unit and fuel pump (main) harness connector B17 terminal 2 (G/B) and unified meter and A/C amp. harness connector M50 terminal 28 (G/B).

**2 (G/B) – 28 (G/B) : Continuity should exist.**

3. Check continuity between fuel level sensor unit and fuel pump (main) harness connector B17 terminal 2 (G/B) and ground.

**2 (G/B) – Ground : Continuity should not exist.**

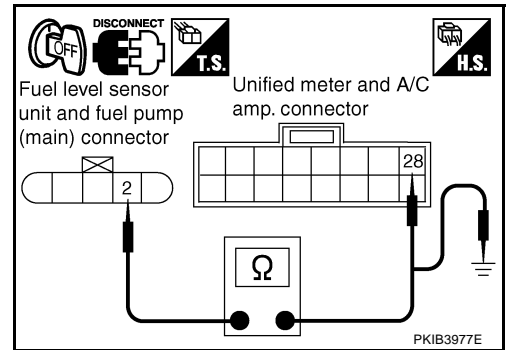

OK or NG

OK >> GO TO 4.

NG >> Repair harness or connector.

## 4. CHECK FUEL LEVEL SENSOR (MAIN) CIRCUIT 2

1. Check continuity between fuel level sensor unit and fuel pump (main) harness connector B17 terminal 5 (B/W) and unified meter and A/C amp. harness connector M50 terminal 36 (B/W).

**5 (B/W) – 36 (B/W) : Continuity should exist.**

2. Check continuity between fuel level sensor unit and fuel pump (main) harness connector B17 terminal 5 (B/W) and ground.

**5 (B/W) – Ground : Continuity should not exist.**

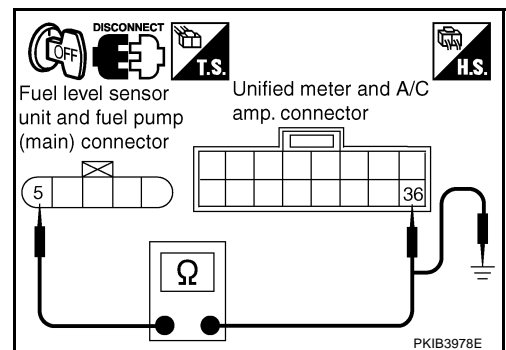

OK or NG

OK >> GO TO 5.

NG >> Repair harness or connector.

## 5. CHECK INSTALLATION CONDITION

Check fuel level sensor unit installation, and check whether the float arm interferes or binds with any of the internal components in the fuel tank.

OK or NG

OK >> Replace unified meter and A/C amp. Refer to [DI-37, "Removal and Installation of Unified Meter and A/C Amp."](#)

NG >> Install fuel level sensor unit properly.

# COMBINATION METERS

## Odo/Trip Meter and Illumination Control Switch Inspection

AKS00D56

Symptom: Illumination control does not operate.

### 1. CHECK ODO/TRIP METER AND ILLUMINATION CONTROL SWITCH

1. Remove combination meter. Refer to [DI-26, "Disassembly and Assembly of Combination Meter"](#) .
2. Remove meter lid. Refer to [DI-26, "Disassembly and Assembly of Combination Meter"](#) .
3. Check continuity between odo/trip meter and illumination control switch connector M303 terminals 3, 4 or 5 and 6.

Terminal	Condition	Continuity
3	Illumination control switch (+) is pushed.	Yes
	Illumination control switch (+) is released.	No
4	Illumination control switch (-) is pushed.	Yes
	Illumination control switch (-) is released.	No
5	Odo/trip meter switch is pushed.	Yes
	Odo/trip meter switch is released.	No

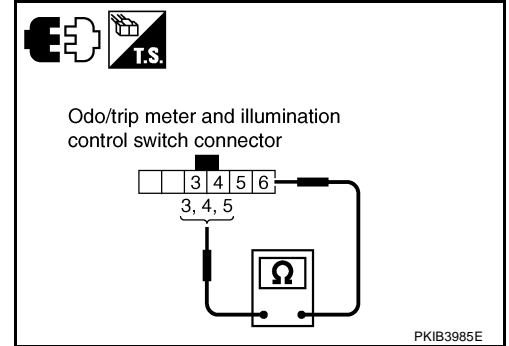

OK or NG

- OK >> Replace combination meter.
- NG >> Replace odo/trip meter and illumination control switch.

## Fuel Gauge Pointer Fluctuates, Indicator Wrong Value or Varies

AKS00D57

### 1. CHECK FUEL GAUGE FLUCTUATION

Test drive vehicle to see if gauge fluctuates only during driving or at the instant of stopping.

Does the indication value vary only during driving or at the instant of stopping?

- YES >> The pointer fluctuation may be caused by fuel level change in the fuel tank. Condition is normal.
- NO >> Ask the customer about the situation when the symptom occurs in detail, and perform the trouble diagnosis.

## Fuel Gauge Does Not Move to FULL Position

AKS00D58

### 1. QUESTION 1

Does it take a long time for the pointer to move to FULL position?

- YES >> GO TO 2.
- NO >> GO TO 3.

### 2. QUESTION 2

Was the vehicle fueled with the ignition switch ON?

- YES >> Be sure to fuel the vehicle with the ignition switch OFF. Otherwise, it will take a long time to move to FULL position because of the characteristic of the fuel gauge.
- NO >> GO TO 3.

### 3. QUESTION 3

Is the vehicle parked on an incline?

- YES >> Check the fuel level indication with vehicle on a level surface.
- NO >> GO TO 4.

## COMBINATION METERS

---

### 4. QUESTION 4

---

During driving, does the fuel gauge pointer move gradually toward EMPTY position?

- YES >> Check the fuel level sensor unit. Refer to [DI-25. "FUEL LEVEL SENSOR UNIT CHECK"](#) .
- NO >> The float arm may interfere or bind with any of the components in the fuel tank.



# COMBINATION METERS

## Electrical Components Inspection FUEL LEVEL SENSOR UNIT CHECK

AKS00D59

For removal, refer to [FL-4, "FUEL LEVEL SENSOR UNIT, FUEL FILTER AND FUEL PUMP ASSEMBLY"](#).

### Check Fuel Level Sensor Unit and Fuel Pump (Main)

Check resistance between fuel level sensor unit and fuel pump (main) connector terminals 2 and 6.

Terminal		Float position [mm (in)]		Resistance value [ $\Omega$ ]	
2	6	*1	Empty	15 (0.59)	Approx. 81.5
		*2	Full	193 (7.6)	

\*1 and \*2: When float rod is in contact with stopper.

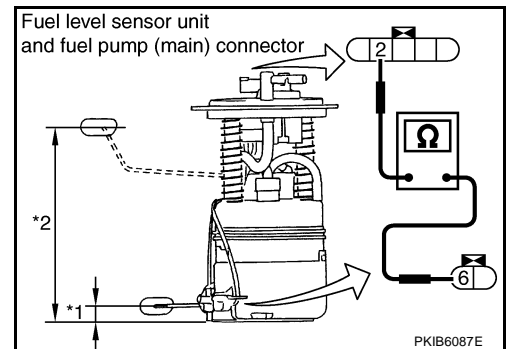

### Check Fuel Level Sensor Unit and Pump (Main) Harness

Check continuity between fuel level sensor unit and fuel pump (main) connector terminals 5 and 7.

**5 - 7 : Continuity should exist.**

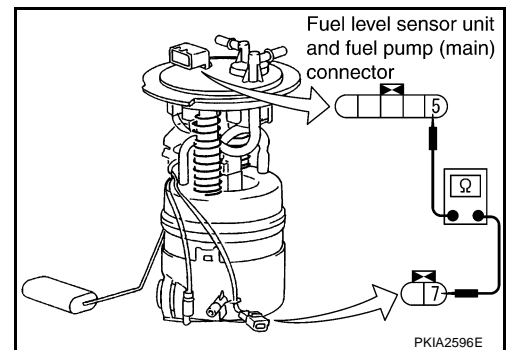

### Check Fuel Level Sensor Unit (Sub)

Check resistance between fuel level sensor unit and fuel pump (main) connector terminals 6 and 7.

Terminal		Float position [mm (in)]		Resistance value [ $\Omega$ ]	
6	7	*1	Empty	10 (0.39)	Approx. 45.2
		*2	Full	198 (7.8)	

\*1 and \*2: When float rod is in contact with stopper.

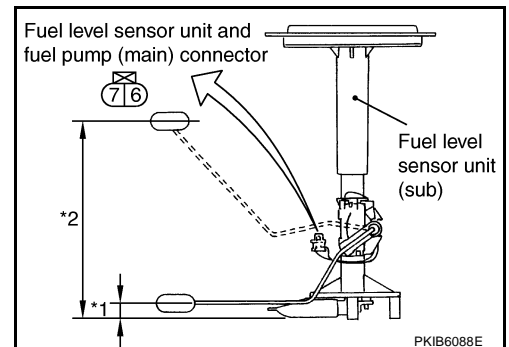

## Removal and Installation of Combination Meter REMOVAL

AKS00D5A

1. Remove instrument driver lower panel. Refer to [IP-11, "Removal and Installation"](#).
2. Remove steering column cover. Refer to [IP-11, "Removal and Installation"](#).
3. Remove screws (2) and remove combination meter.

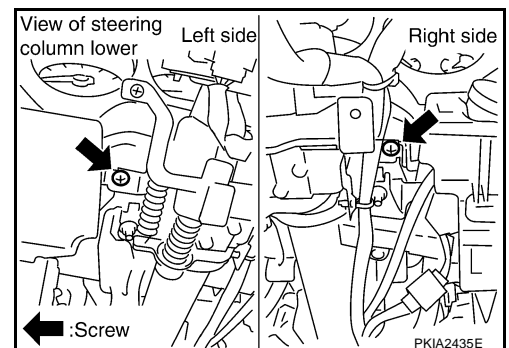

## INSTALLATION

Installation is the reverse order of removal.

# COMBINATION METERS

## Disassembly and Assembly of Combination Meter

AKS00D5B

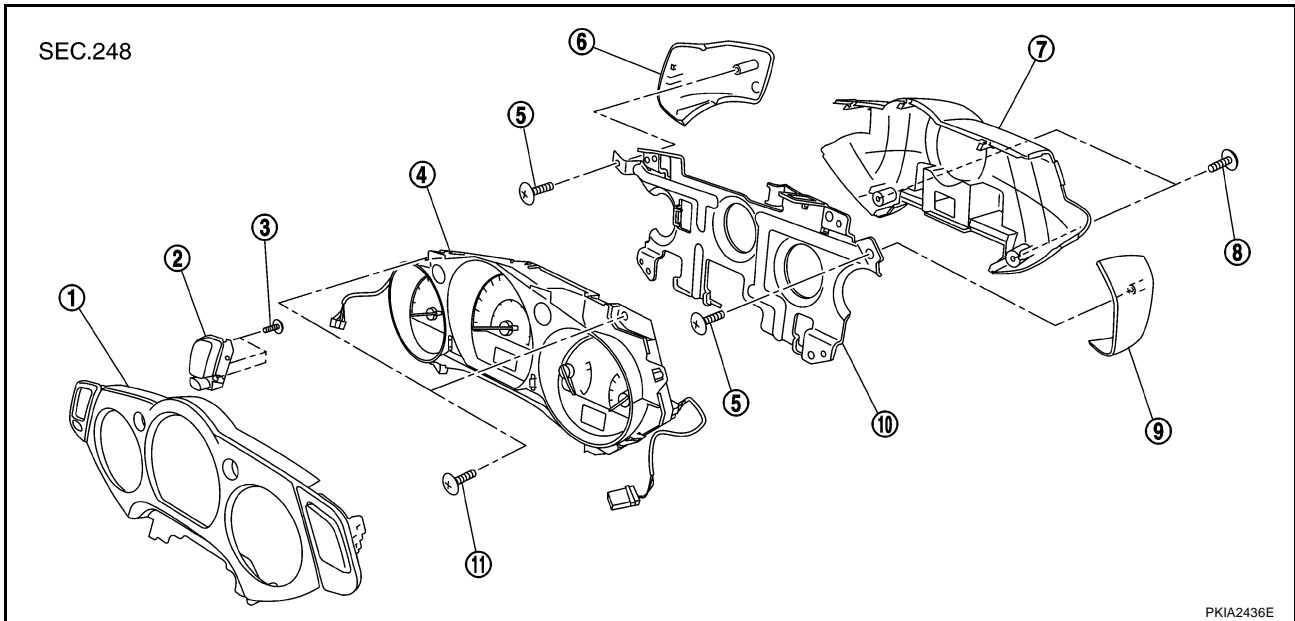

- |  |   |                              |
|--|---|------------------------------|
| 1. Meter lid                           | 2. Odo/trip meter and illumination control switch | 3. Screws                    |
| 4. Unified meter control unit assembly | 5. Screws   | 6. Switch cover (Left side)  |
| 7. Rear cover                          | 8. Screws   | 9. Switch cover (Right side) |
| 10. Bracket                            | 11. Screws  |                              |

### DISASSEMBLY

1. Remove screws (2). Disconnect odo/trip meter and illumination control switch and hazard switch connectors and remove meter lid.

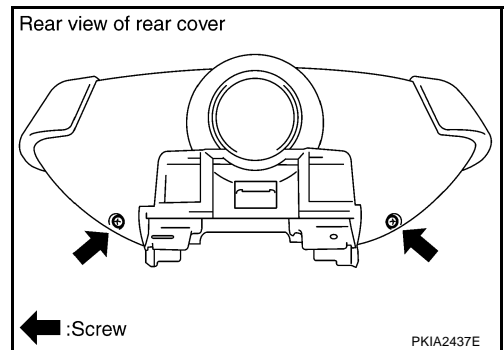

2. Remove screws (3) and remove odo/trip meter and illumination control switch.

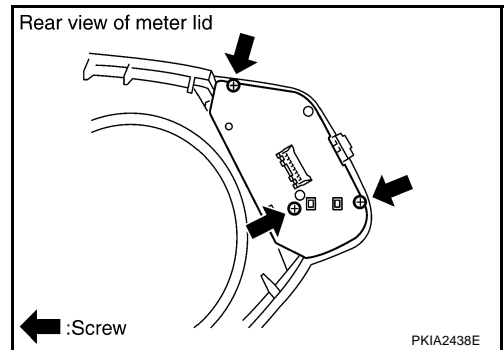

# COMBINATION METERS

3. Remove screws (2) and remove switch cover.

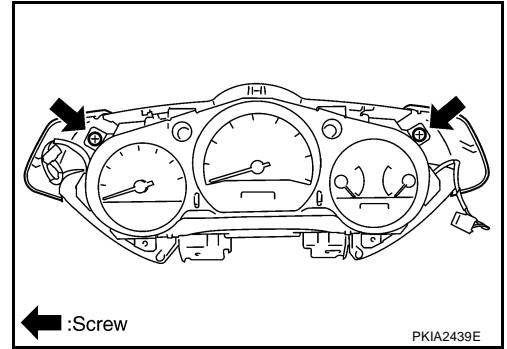

4. Remove screws (2) and remove rear cover.
5. Disengaged the tabs (2) to separate bracket.
6. Remove bulbs.

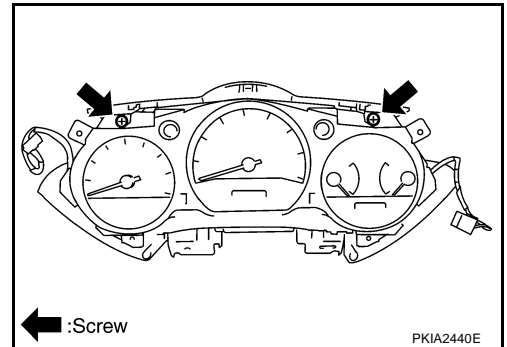

## ASSEMBLY

Assembly is the reverse order of disassembly.

A  
B  
C  
D  
E  
F  
G  
H  
I  
J  
DI  
L  
M

# UNIFIED METER AND A/C AMP

## UNIFIED METER AND A/C AMP

PFP:27760

### System Description

AKS00D5C

- For the unified meter and A/C amp., the signal required for controlling the combination meter are integrated in the A/C auto amp.
- Unified meter and A/C amp. controls each operation for A/C auto amp. For information regarding A/C control, refer to [ATC-25, "AIR CONDITIONER CONTROL"](#) in ATC section.
- Unified meter and A/C amp. inputs necessary information for combination meter from each unit by CAN communication and so on.
- And unified meter and A/C amp. outputs these signals using communication line (TX, RX) between unified meter and A/C amp. and combination meter.
- Other input signals are also sent to the ECM, TCM, AWD control unit, BCM, display unit (without NAVI) and display control unit (with NAVI) using CAN communication.
- The signals required for the distance to empty (DTE) display are centralized in the unified meter and A/C amp., converted into data, and sent to the display unit (without NAVI) or display control unit (with NAVI) using CAN communication.
- The unified meter and A/C amp. have a CONSULT-II function (self-diagnostic results, CAN diagnostic support monitor, data monitor).

### INPUT/OUTPUT SIGNALS

#### Between Unified Meter and A/C Amp. and Combination Meter

Unit	Input	Output
Unified meter and A/C amp.	<ul style="list-style-type: none"> <li>● Seat belt buckle switch signal (Driver's side)</li> <li>● Parking brake signal</li> <li>● Illumination control nighttime required signal</li> <li>● Refuel status signal</li> <li>● Low-fuel warning lamp condition signal</li> <li>● Combination meter receive error signal</li> <li>● Delivery destination data signal</li> <li>● Combination meter specifications signal</li> </ul>	<ul style="list-style-type: none"> <li>● Vehicle speed signal (8-pulse)</li> <li>● Engine speed signal</li> <li>● Engine coolant temperature signal</li> <li>● Fuel level sensor signal (resistance value)</li> <li>● Malfunction indicator signal</li> <li>● ABS warning lamp signal</li> <li>● Low tire pressure warning signal</li> <li>● Brake warning lamp signal</li> <li>● AWD warning lamp signal</li> <li>● Turn indicator signal</li> <li>● High beam request signal</li> <li>● VDC OFF indicator lamp signal</li> <li>● SLIP indicator lamp signal</li> <li>● CRUISE indicator lamp signal</li> <li>● SET indicator lamp signal</li> <li>● AWD lock indicator lamp signal</li> <li>● CVT indicator lamp signal</li> <li>● CVT position indicator signal</li> <li>● Manual mode indicator signal</li> <li>● Manual mode gear position signal</li> <li>● Second position indicator signal</li> <li>● CAN communication condition signal of CVT</li> <li>● Door switch signal</li> <li>● Oil pressure switch signal</li> <li>● Position lights request signal</li> <li>● Buzzer output signal</li> </ul>

# UNIFIED METER AND A/C AMP

## FAIL-SAFE

### Solution When Communication Error Between the Unified Meter & A/C Amp. and the Combination Meter

Function		Specifications
Speedometer		Reset to zero by suspending communication.
Tachometer		
Fuel gauge		
Water temperature gauge		
Illumination control	Combination meter illumination	When suspending communication, change to nighttime mode.
Odo/trip meter		Integrate in response to 8-pulse input.
CVT position indicator		The display turns off by suspending communication.
Warning buzzer		The warning buzzer turns off by suspending communication.
Warning lamp/indicator lamp	ABS warning lamp	The lamp turns on by suspending communication.
	VDC OFF indicator	
	SLIP indicator	
	Brake warning lamp	
	High beam indicator	The lamp turns off by suspending communication.
	Door warning lamp	
	Low tire pressure warning lamp	
	SET indicator lamp	
	CRUISE indicator lamp	
	AWD warning lamp	
	AWD LOCK indicator lamp	
	Oil pressure warning lamp	
	Turn signal indicator	
	Malfunction indicator lamp	
CVT indicator lamp		

## CAN Communication System Description

AKS00D5D

CAN (Controller Area Network) is a serial communication line for real time application. It is an on-vehicle multiplex communication line with high data communication speed and excellent error detection ability. Many electronic control units are equipped onto a vehicle, and each control unit shares information and links with other control units during operation (not independent). In CAN communication, control units are connected with 2 communication lines (CAN H line, CAN L line) allowing a high rate of information transmission with less wiring. Each control unit transmits/receives data but selectively reads required data only.

## CAN Communication Unit

AKS00D5E

Refer to [LAN-29, "CAN Communication Unit"](#) in "LAN SYSTEM".

# UNIFIED METER AND A/C AMP

## Schematic

AKS00D5F

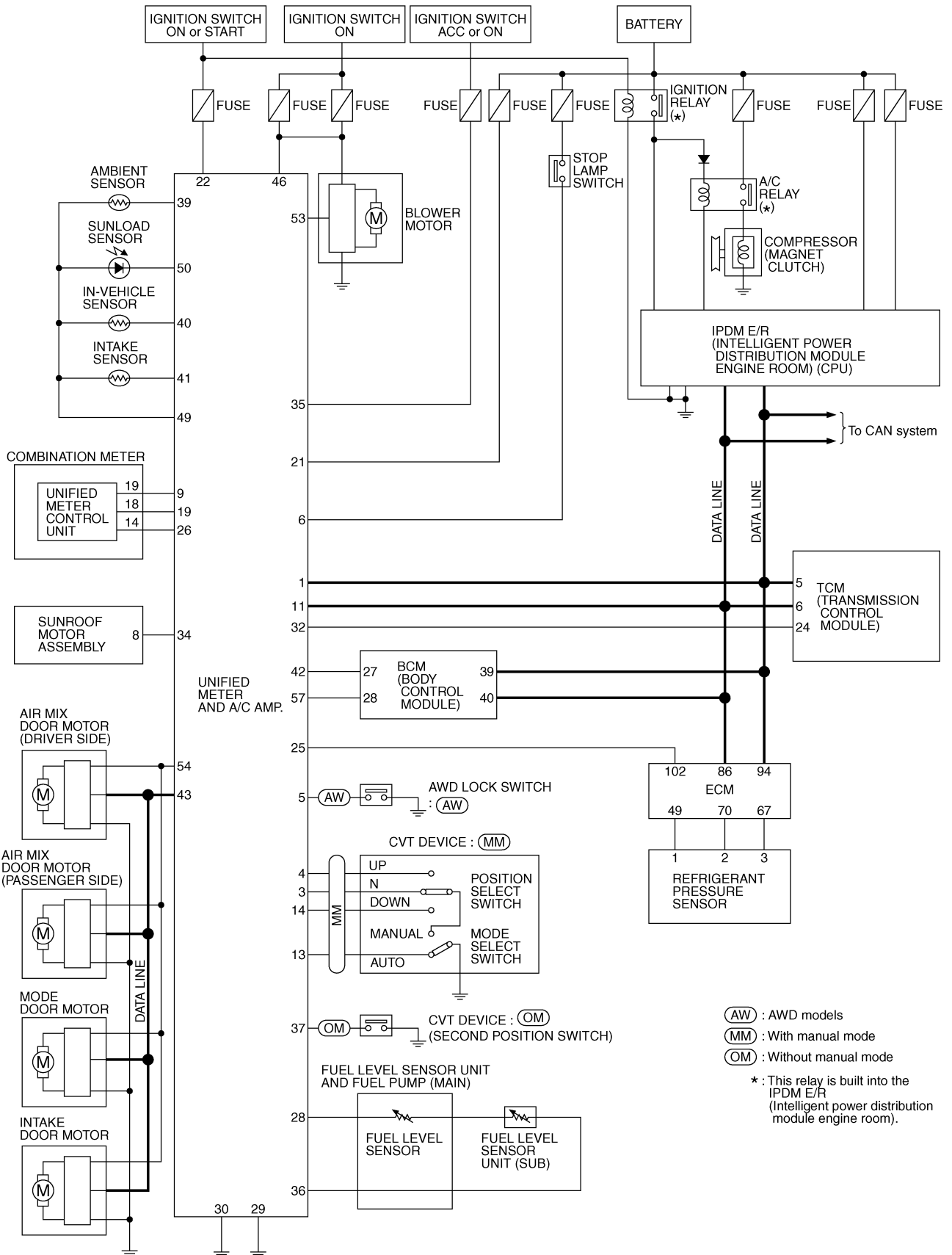

TKWA1707E

# UNIFIED METER AND A/C AMP

## CONSULT-II Function (METER A/C AMP)

AKS00D5G

CONSULT-II can display each diagnostic item using the diagnostic test modes shown following.

System	Diagnosis mode	Description	Reference page
METER A/C AMP	Self-diagnosis results	Unified meter and A/C amp. check the conditions and indicates any error that unified meter and A/C amp. memorized.	<a href="#">DI-32</a>
	CAN diagnostic support monitor	The results of transmit/receive diagnosis of CAN communication can be read.	<a href="#">LAN-19</a>
	Data monitor	Displays unified meter and A/C amp. input data in real time.	<a href="#">DI-32</a>

### CONSULT-II BASIC OPERATION

#### CAUTION:

If CONSULT-II is used with no connection of CONSULT-II CONVERTER, malfunctions might be detected in self-diagnosis depending on control unit which carry out CAN communication.

1. With the ignition switch OFF, connect "CONSULT-II" and "CONSULT-II CONVERTER" to the data link connector, then turn ignition switch ON.

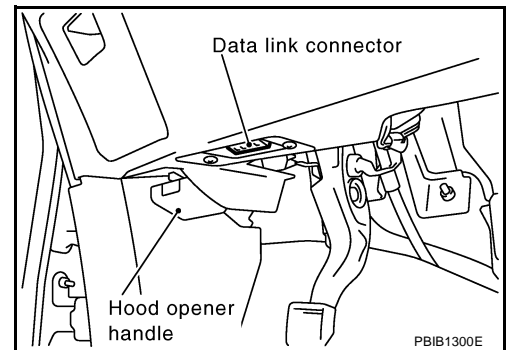

2. Touch "START (NISSAN BASED VHCL)".

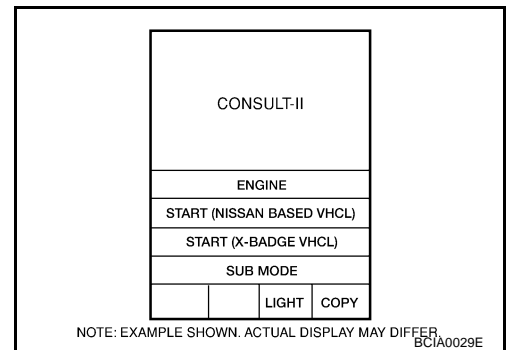

3. Touch "METER A/C AMP" on "SELECT SYSTEM" screen. If "METER A/C AMP" is not indicated, go to [GI-39, "CONSULT-II Data Link Connector \(DLC\) Circuit"](#).

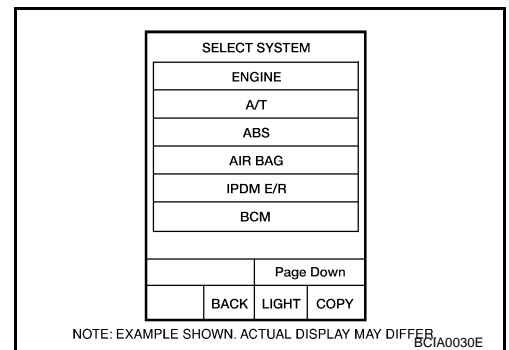

# UNIFIED METER AND A/C AMP

- Select "SELF-DIAG RESULTS", "CAN DIAG SUPPORT MNTR" or "DATA MONITOR".

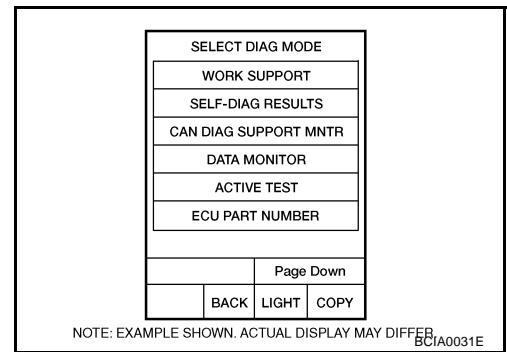

## SELF-DIAGNOSTIC RESULTS

### Operation Procedure

- Touch "SELF-DIAG RESULTS" on "SELECT DIAG MODE" screen.
- Self-diagnosis results are displayed.

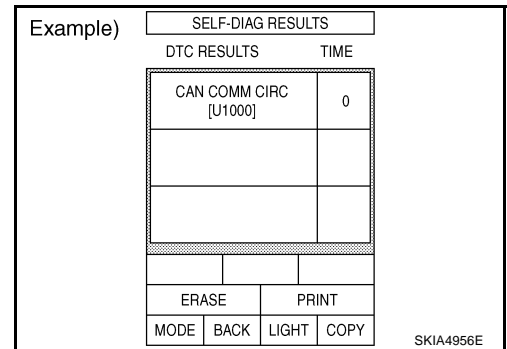

### Display Item List

CONSULT-II display	Malfunction is detected when...	Reference page
CAN COMM CIRC [U1000]	Malfunction is detected in CAN communication. <b>CAUTION:</b> Even when there is no malfunction on CAN communication system, malfunction may be misinterpreted when battery has low voltage (when maintaining 7 - 8 V for about 2 seconds) or 10A fuse [No. 19, located in the fuse block (J/B)] is disconnected.	<a href="#">DI-34</a>
METER COMM CIRC [B2202]	Malfunction is detected in communication of between combination meter and unified meter and A/C amp.	<a href="#">DI-34</a>
VEHICLE SPEED CIRC [B2205]	When an erroneous speed signal is input for 1 seconds. <b>CAUTION:</b> Even when there is no malfunction on speed signal system, malfunction may be misinterpreted when battery has low voltage (when maintaining 7 - 8 V for about 2 seconds).	<a href="#">DI-37</a>

"TIME" indicates the condition of the self-diagnosis results judged by each signal input.

- Normal: In case of operating properly at the present in spite of having malfunction in the past, then "TIME" indicates "1-63".
- Malfunction: Soon after detecting malfunctions by self-diagnoses or current malfunction, "0" is indicated.

After returning to normal condition, every time when ignition switch is turned to "OFF" from "ON", time will be added like "1"→"2"→"3"..."63", and when the key operation is performed 64 times, the result of the self-diagnoses will be erased. And if any malfunction is detected again, "0" will be indicated.

### CAUTION:

"TIME" keeps showing "0" after returning to normal condition only in the case that malfunction history of "CAN COMM CIRC [U1000]" remains because of low tire pressure warning control unit, display control unit (with NAVI) or display unit (without NAVI) malfunction.

## DATA MONITOR

### Operation Procedure

- Touch "DATA MONITOR" on "SELECT DIAG MODE" screen.
- Touch either "MAIN SIGNALS" or "SELECTION FROM MENU" on the "DATA MONITOR" screen.



# UNIFIED METER AND A/C AMP

MAIN SIGNALS	Monitors main signals.
SELECTION FROM MENU	Selects and monitors individual signal.

3. When "SELECTION FROM MENU" is selected, touch individual items to be monitored. When "MAIN SIGNALS" is selected, main items will be monitored.
4. Touch "START".
5. Touch "RECORD" while monitoring, then the status of the monitored item can be recorded. To stop recording, touch "STOP".

Example)

DATA MONITOR	
MONITOR	
SPEED METER	0.0km/h
SPEED OUTPUT	0.0km/h
TACHO METER	0 rpm
W TEMP METER	26°C
FUEL METER	6 lit.
DISTANCE	0 km
FUEL W/L	ON
BUZZER	OFF
M RANGE SW	OFF
Page Down	
STOP	
MODE	BACK
LIGHT	COPY

SKIA4957E

## Display Item List

Display item [Unit]	MAIN SIGNALS	SELECTION FROM MENU	Contents
SPEED METER [km/h] or [mph]	X	X	This is the angle correction value after the speed signal from the ABS actuator and electric unit (control unit) is converted into the vehicle speed.
SPEED OUTPUT [km/h] or [mph]	X	X	This is the angle correction value before the speed signal from the ABS actuator and electric unit (control unit) is converted into the vehicle speed.
TACHO METER [rpm]	X	X	This is the converted value for the engine speed signal from the ECM.
W TEMP METER [°C] or [°F]	X	X	This is the converted value for the engine coolant temperature signal from the ECM.
FUEL METER [lit.]	X	X	This is the processed value for the signal (resistance value) from the fuel gauge.
DISTANCE [km] or [mile]	X	X	This is the calculated value for the speed signal from the ABS actuator and electric unit (control unit), the signal (resistance signal) from the fuel gauge and fuel consumption from ECM.
FUEL W/L [ON/OFF]	X	X	Indicates [ON/OFF] condition of low-fuel warning lamp.
MIL [ON/OFF]		X	Indicates [ON/OFF] condition of malfunction indicator lamp.
AIR PRES W/L [ON/OFF]		X	Indicates [ON/OFF] condition of low tire pressure warning lamp.
SEAT BELT W/L [ON/OFF]		X	Indicates [ON/OFF] condition of seat belt warning lamp.
BUZZER [ON/OFF]	X	X	Indicates [ON/OFF] condition of buzzer.
DOOR W/L [ON/OFF]		X	Indicates [ON/OFF] condition of door warning lamp.
HI-BEAM IND [ON/OFF]		X	Indicates [ON/OFF] condition of high beam indicator.
TURN IND [ON/OFF]		X	Indicates [ON/OFF] condition of turn indicator.
OIL W/L [ON/OFF]		X	Indicates [ON/OFF] condition of oil pressure warning lamp.
VDC/TCS IND [ON/OFF]		X	Indicates [ON/OFF] condition of VDC/TCS OFF indicator lamp.
ABS W/L [ON/OFF]		X	Indicates [ON/OFF] condition of ABS warning lamp.
SLIP IND [ON/OFF]		X	Indicates [ON/OFF] condition of SLIP indicator lamp.
BRAKE W/L [ON/OFF]		X	Indicates [ON/OFF] condition of brake warning lamp. *1
M RANGE SW [ON/OFF] *2	X	X	Indicates [ON/OFF] condition of manual mode range switch.
NM RANGE SW [ON/OFF] *2	X	X	Indicates [ON/OFF] condition of except for manual mode range switch.
AT SFT UP SW [ON/OFF] *2	X	X	Indicates [ON/OFF] condition of CVT shift-up switch.
AT SFT DWN SW [ON/OFF] *2	X	X	Indicates [ON/OFF] condition of CVT shift-down switch.

# UNIFIED METER AND A/C AMP

Display item [Unit]	MAIN SIGNALS	SELECTION FROM MENU	Contents
O/D OFF SW [ON/OFF]		X	Indicates [ON/OFF] condition of CVT device (second position switch).
BRAKE SW [ON/OFF]		X	Indicates [ON/OFF] condition of brake switch (stop lamp switch).
AT-M IND [ON/OFF] *2	X	X	Indicates [ON/OFF] condition of CVT manual mode indicator.
AT-M GEAR [5-1] *3	X	X	Indicates [5-1] condition of CVT manual mode gear position.
P RANGE IND [ON/OFF]	X	X	Indicates [ON/OFF] condition of CVT shift P range indicator.
R RANGE IND [ON/OFF]	X	X	Indicates [ON/OFF] condition of CVT shift R range indicator.
N RANGE IND [ON/OFF]	X	X	Indicates [ON/OFF] condition of CVT shift N range indicator.
D RANGE IND [ON/OFF]	X	X	Indicates [ON/OFF] condition of CVT shift D range indicator.
L RANGE IND [ON/OFF]	X	X	Indicates [ON/OFF] condition of CVT shift L range indicator.
CVT IND [ON/OFF]		X	Indicates [ON/OFF] condition of CVT indicator.
S RANGE IND [ON/OFF]	X	X	Indicates [ON/OFF] condition of CVT shift S range indicator.
CRUISE IND [ON/OFF]		X	Indicates [ON/OFF] condition of CRUISE indicator.
SET IND [ON/OFF]		X	Indicates [ON/OFF] condition of SET indicator.
4WD LOCK SW [ON/OFF]		X	Indicates [ON/OFF] condition of AWD lock switch.
4WD LOCK IND [ON/OFF]		X	Indicates [ON/OFF] condition of AWD lock indicator lamp.
4WD W/L [ON/OFF]		X	Indicates [ON/OFF] condition of AWD warning lamp.

**NOTE:**

Any monitored item that does not match the vehicle being diagnosed is deleted from the display automatically.

\*1: Monitor keeps indicating "OFF" when brake warning lamp is on by the parking brake operation or low brake fluid level.

\*2: Vehicles without manual mode always indicates "OFF".

\*3: Vehicles without manual mode always indicates "1".

## DTC [U1000] CAN Communication Circuit

AKS00D5H

Symptom: Display CAN COMM CIRC [U1000] at the result of self-diagnosis for unified meter and A/C amp.

### 1. CHECK CAN COMMUNICATION

1. Select "SELF-DIAG RESULTS" mode for "METER A/C AMP" with CONSULT-II.
2. Print out CONSULT-II screen.

>> Go to "CAN system". Refer to [LAN-5, "Precautions When Using CONSULT-II"](#).

## DTC [B2202] Meter Communication Circuit

AKS00D5I

Symptom: Display METER COMM CIRC [B2202] at the result of self-diagnosis for unified meter and A/C amp.

### 1. CHECK CONNECTOR

Check combination meter, unified meter and A/C amp. and terminals (combination meter side, unified meter and A/C amp. side and harness side) for looseness or bent terminals.

OK or NG

OK >> GO TO 2.

NG >> Repair terminal or connector.

### 2. CHECK METER/GAUGES VISUALLY

Check the pointer on the meter/gauges fluctuate at the engine start.

Is the fluctuation acceptable?

YES >> GO TO 3.

NO >> GO TO 6.

# UNIFIED METER AND A/C AMP

## 3. CHECK CONTINUITY COMMUNICATION CIRCUIT (TX: COMBINATION METER)

1. Turn ignition switch OFF.
2. Disconnect combination meter connector and unified meter and A/C amp. connector.
3. Check continuity between combination meter harness connector M25 terminal 18 (R/L) and unified meter and A/C amp. harness connector M49 terminal 19 (R/L).

**18 (R/L) – 19 (R/L) : Continuity should exist.**

4. Check continuity between combination meter harness connector M25 terminal 18 (R/L) and ground.

**18 (R/L) – Ground : Continuity should not exist.**

OK or NG

OK >> GO TO 4.

NG >> Repair harness or connector.

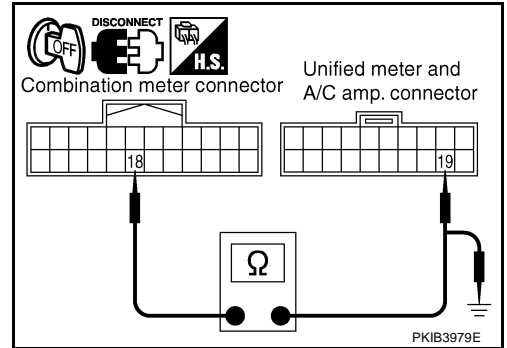

## 4. CHECK VOLTAGE OF UNIFIED METER AND A/C AMP.

1. Connect unified meter and A/C amp. connector.
2. Turn ignition switch ON.
3. Check voltage between combination meter harness connector M25 terminal 18 (R/L) and ground.

**18 (R/L) – Ground : Approx. 5 V**

OK or NG

OK >> GO TO 5.

NG >> Replace unified meter and A/C amp. Refer to [DI-37, "Removal and Installation of Unified Meter and A/C Amp."](#)

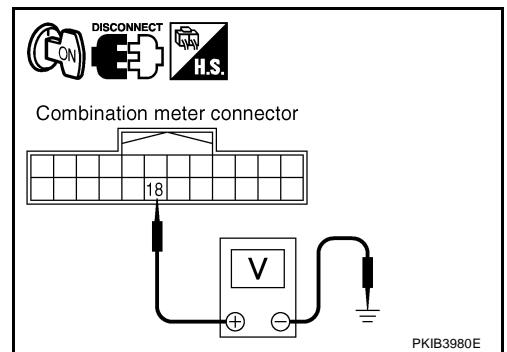

## 5. CHECK VOLTAGE SIGNAL OF COMBINATION METER

1. Turn ignition switch OFF and connect combination meter connector.
2. Turn ignition switch ON.
3. Check voltage signal between combination meter harness connector M25 terminal 18 (R/L) and ground.

**18 (R/L) – Ground:**

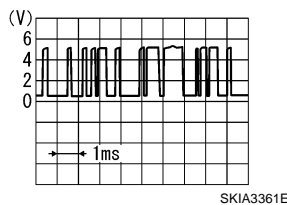

OK or NG

OK >> Replace unified meter and A/C amp. Refer to [DI-37, "Removal and Installation of Unified Meter and A/C Amp."](#)

NG >> Replace combination meter.

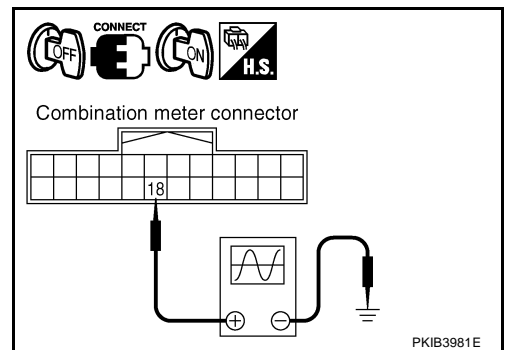

# UNIFIED METER AND A/C AMP

## 6. CHECK CONTINUITY COMMUNICATION CIRCUIT (RX: COMBINATION METER)

1. Turn ignition switch OFF.
2. Disconnect combination meter connector and unified meter and A/C amp. connector.
3. Check continuity between combination meter harness connector M25 terminal 19 (R/B) and unified meter and A/C amp. harness connector M49 terminal 9 (R/B).

**19 (R/B) – 9 (R/B) : Continuity should exist.**

4. Check continuity between combination meter harness connector M25 terminal 19 (R/B) and ground.

**19 (R/B) – Ground : Continuity should not exist.**

OK or NG

OK >> GO TO 7.

NG >> Repair harness or connector.

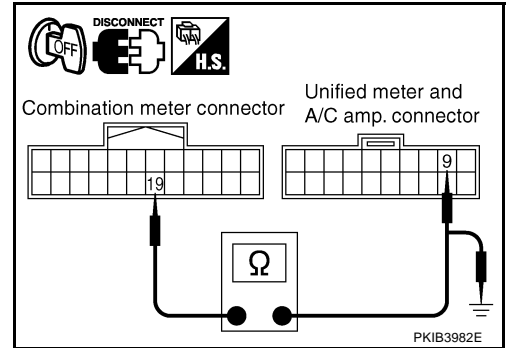

## 7. CHECK VOLTAGE OF COMBINATION METER

1. Connect combination meter connector.
2. Turn ignition switch ON.
3. Check voltage between unified meter and A/C amp. harness connector M49 terminal 9 (R/B) and ground.

**9 (R/B) – Ground : Approx. 5 V**

OK or NG

OK >> GO TO 8.

NG >> Replace combination meter.

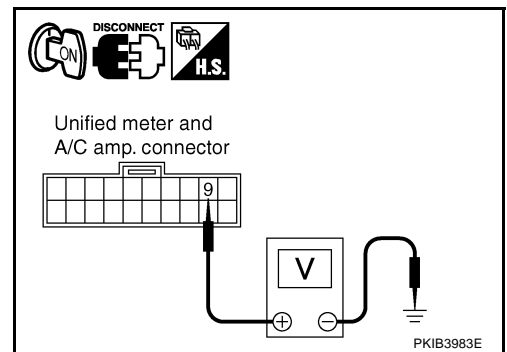

## 8. CHECK VOLTAGE SIGNAL OF UNIFIED METER AND A/C AMP.

1. Turn ignition switch OFF and connect unified meter and A/C amp. connector.
2. Turn ignition switch ON.
3. Check voltage signal between combination meter harness connector M25 terminal 19 (R/B) and ground.

**19 (R/B) – Ground:**

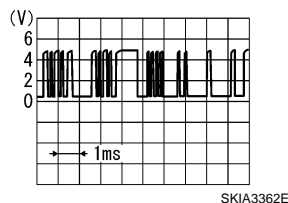

OK or NG

OK >> Replace combination meter.

NG >> Replace unified meter and A/C amp. Refer to [DI-37, "Removal and Installation of Unified Meter and A/C Amp."](#)

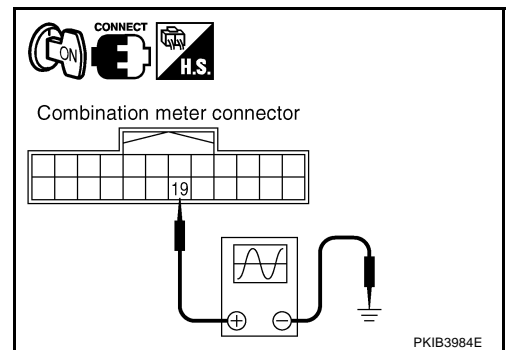

# UNIFIED METER AND A/C AMP

## DTC [B2205] Vehicle Speed Circuit

AKS00D5J

Symptom: Display VEHICLE SPEED CIRC [B2205] at the result of self-diagnosis for unified meter and A/C amp.

### 1. CHECK ABS ACTUATOR AND ELECTRIC UNIT (CONTROL UNIT) SELF-DIAGNOSIS

Perform the ABS actuator and electric unit (control unit) self-diagnosis. Refer to [BRC-70, "CONSULT-II Functions"](#) (with VDC system) or [BRC-20, "CONSULT- II Functions"](#) (without VDC system).

#### Self-diagnostic results content

No malfunction detected >>Replace unified meter and A/C amp.

Malfunction detected >>Check applicable parts, and repair or replace corresponding parts.

## Removal and Installation of Unified Meter and A/C Amp.

AKS00D5K

### REMOVAL

1. Remove the audio unit. Refer to [AV-67, "Removal and Installation of Audio Unit"](#).
2. Remove the fixing screws, then remove the unified meter and A/C amp.

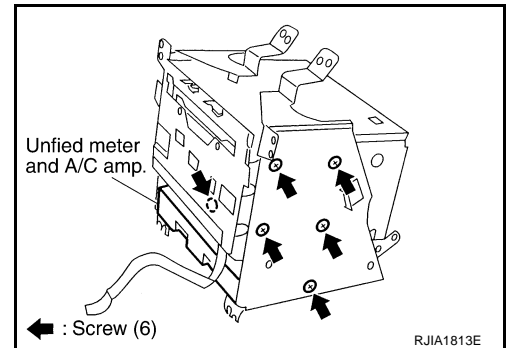

### INSTALLATION

Installation is basically the reverse order of removal.

# COMPASS

## COMPASS

PFP:24835

### System Description

AKS00ABY

This unit displays earth magnetism and heading direction of vehicle.

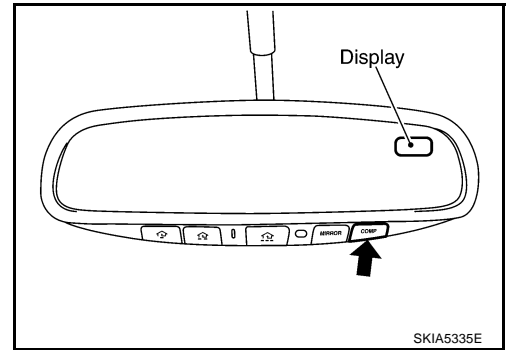

### DIRECTION DISPLAY

Push the switch when the ignition key is in the "ON" or "START" position. The direction will be displayed. Pushing the "COMP" switch a second time will turn off the display.

1. If the display reads "C" calibrate the compass by driving the vehicle in 3 complete circles at less than 8 km/h (5 MPH).
2. To adjust for compass variance:
  - a. Press the "COMP" switch for more than 3 seconds. The current zone number will appear in the display.
  - b. Find your current location and variance zone number on the zone map.
  - c. Press the "COMP" switch until the new zone number appears in the display. After you stop pressing the button in, the display will show a compass direction within a few seconds.

#### NOTE:

1. Do not install the ski rack, antenna, etc. which are attached to the vehicle by means of a magnet. They affect the operation of the compass.
  2. If the compass deviates from the correct indication soon after repeated adjustment, have the compass checked at an authorized dealer.
  3. The compass may not indicate the correct compass point in tunnels or while driving up or down a steep hill. (The compass returns to the correct compass point when the vehicle moves to an area where the geomagnetism is stabilized.)
3. Cleaning the Mirror  
When cleaning the mirror, use a paper towel or similar material dampened with glass cleaner. Do not spray glass cleaner directly on the mirror as that may cause the liquid cleaner to enter the mirror housing.

# COMPASS

## “C” is Displayed In the Compass Window

The compass needs to be calibrated. Drive the vehicle in 3 circles at 8 km/h (5 MPH) or less until the display reads a direction. You can also calibrate the compass by driving your vehicle on your everyday routine. The compass will be calibrated once it has tracked 3 complete circles.

## Inaccurate Compass Direction

1. With the display turned on, push the “COMP” switch for 3 seconds, until the zone selection comes up (a number will be displayed in the mirror compass window).
2. Toggle until correct zone is found and release switch.
3. The display will show all segments, and return to the normal compass mode within 10 seconds of no switch activity.
4. If the vehicle changes zone, repeat steps 1 through 3. See map.

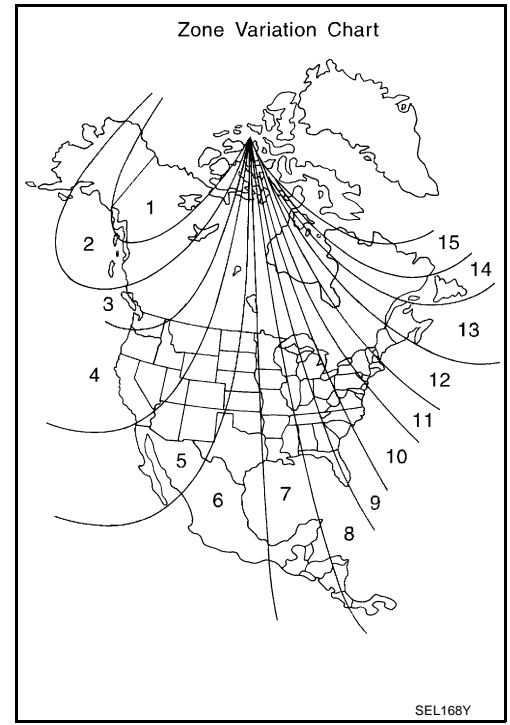

A  
B  
C  
D  
E  
F  
G  
H  
I  
J  
DI  
L  
M

# COMPASS

## Wiring Diagram – COMPASS –

AKS00ABZ

### DI-COMPAS-01

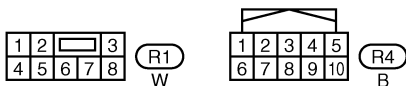
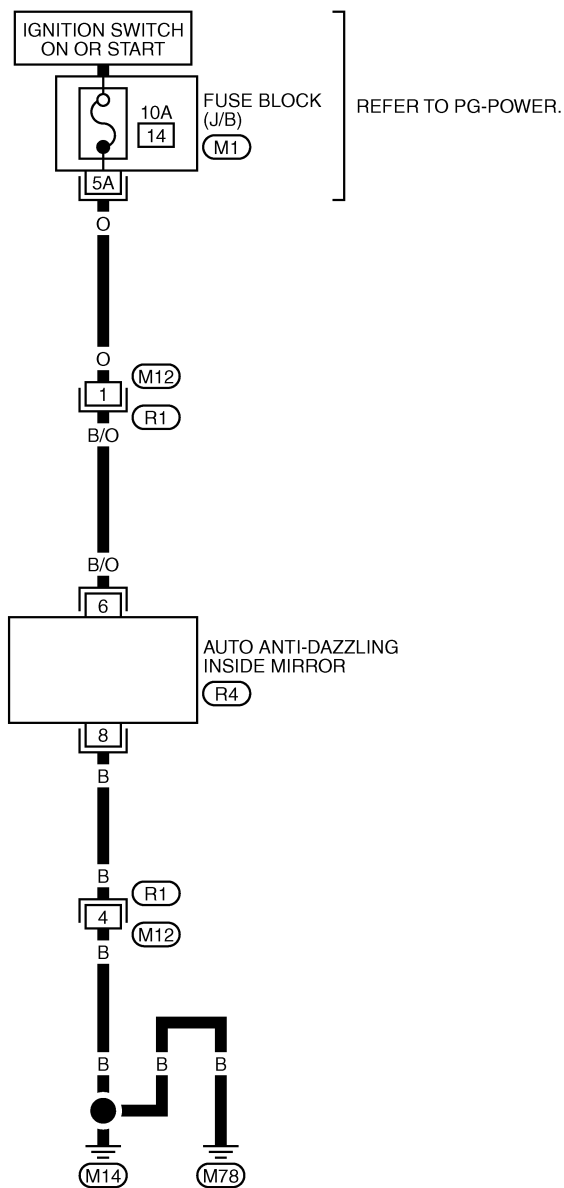

REFER TO THE FOLLOWING.  
 (M1) - FUSE BLOCK-JUNCTION BOX (J/B)

TKWA1428E



---

## Removal and Installation of Compass

AKS00AC0

Refer to [GW-74, "Removal and Installation"](#) .

A

B

C

D

E

F

G

H

I

J

**DI**

L

M

# WARNING LAMPS

## WARNING LAMPS

PF:24814

### Schematic

AKS00D5L

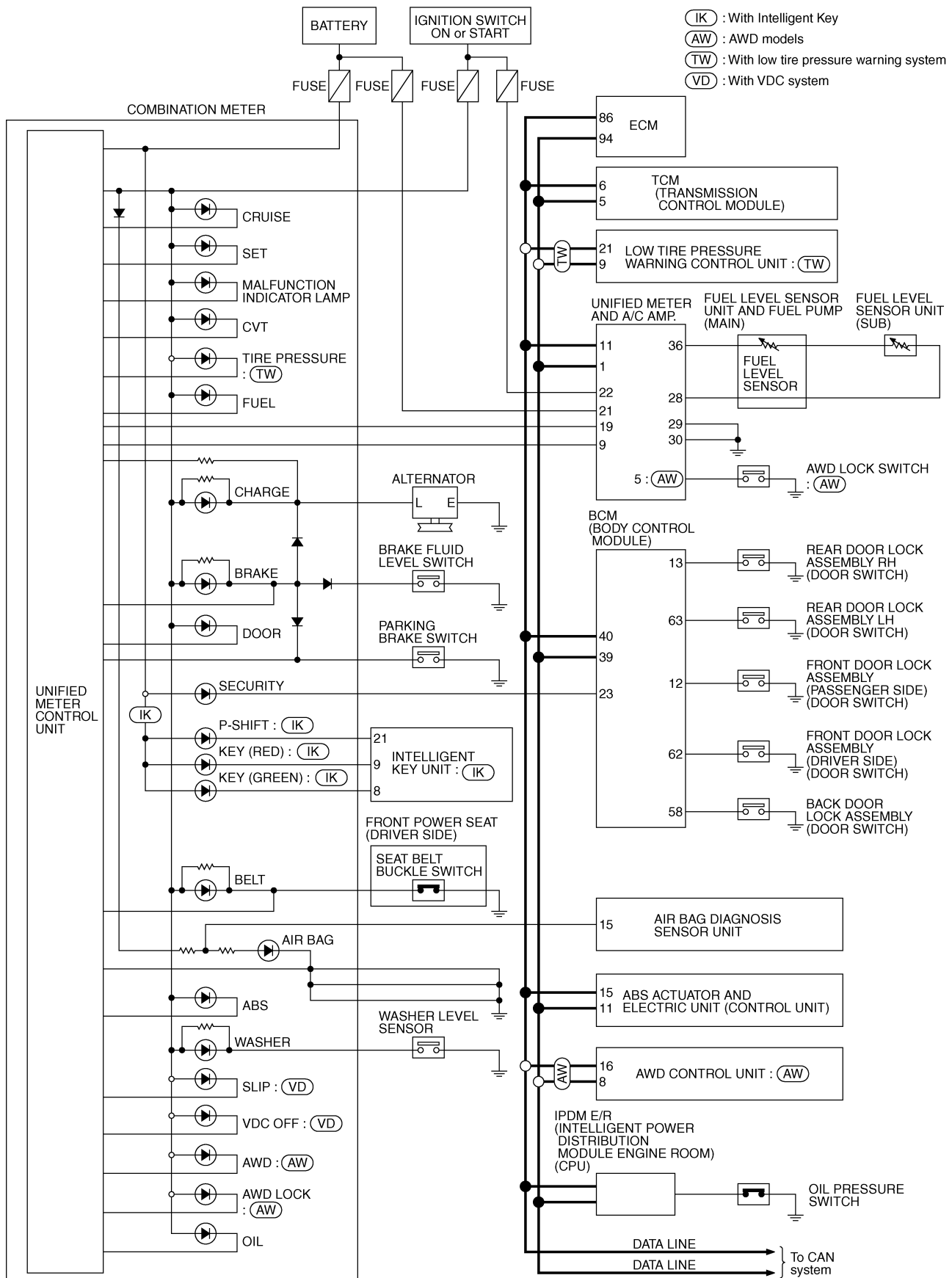

TKWB0482E

# WARNING LAMPS

## Wiring Diagram — WARN —

AKS00D5M

### DI-WARN-01

— — — — — : DATA LINE

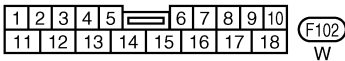
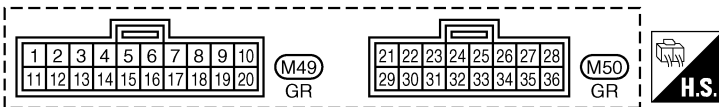
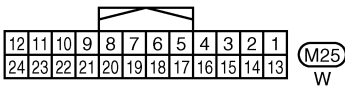
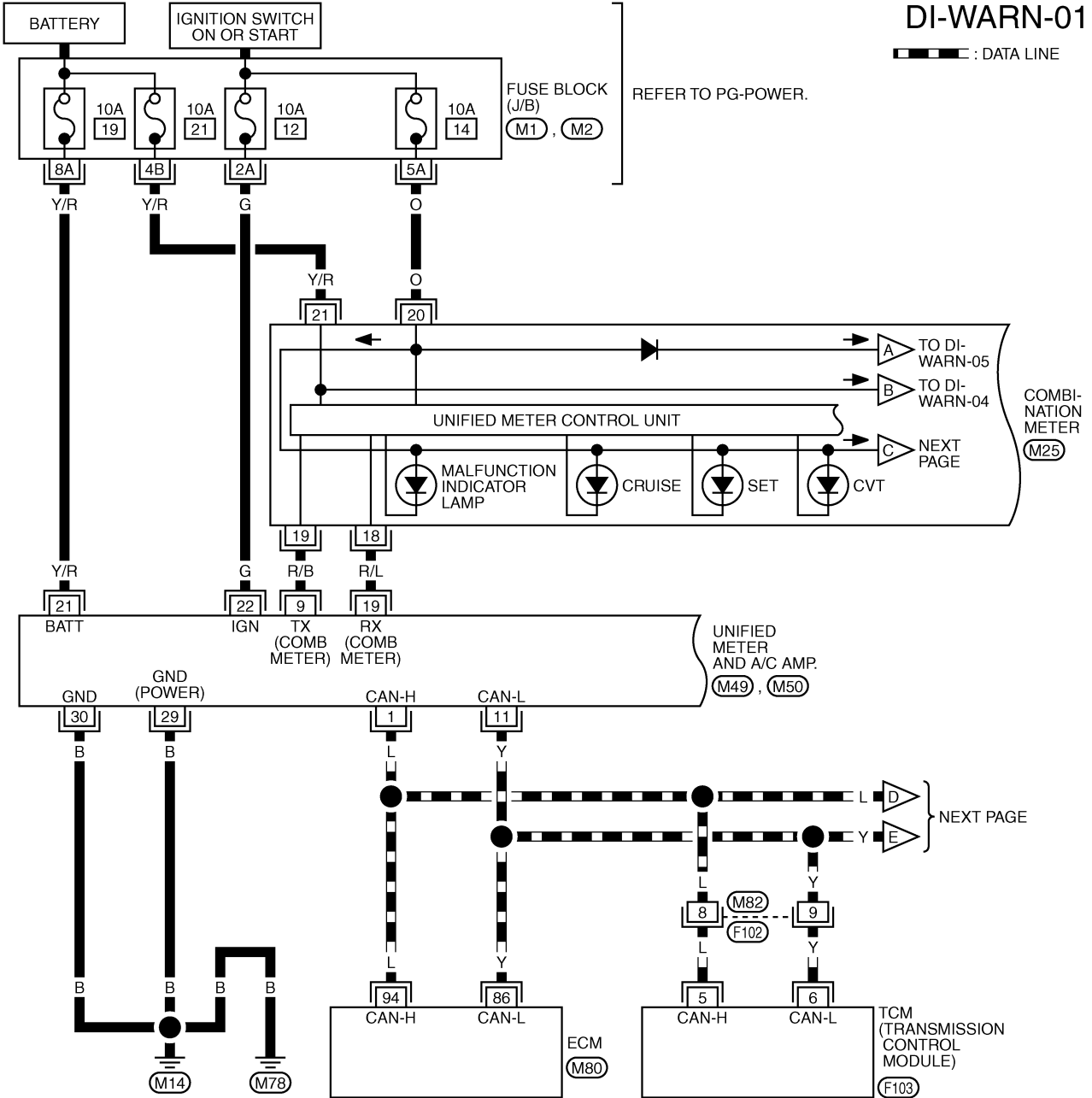

REFER TO THE FOLLOWING.

(M1), (M2) - FUSE BLOCK-JUNCTION BOX (J/B)

(M80), (F103) - ELECTRICAL UNITS

TKWB0483E

# WARNING LAMPS

## DI-WARN-02

— : DATA LINE

◊TW◊ : WITH LOW TIRE PRESSURE WARNING SYSTEM

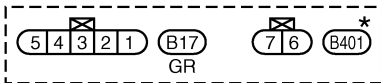
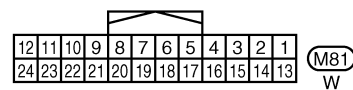
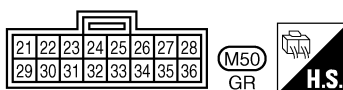
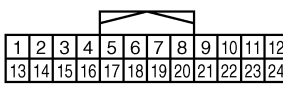
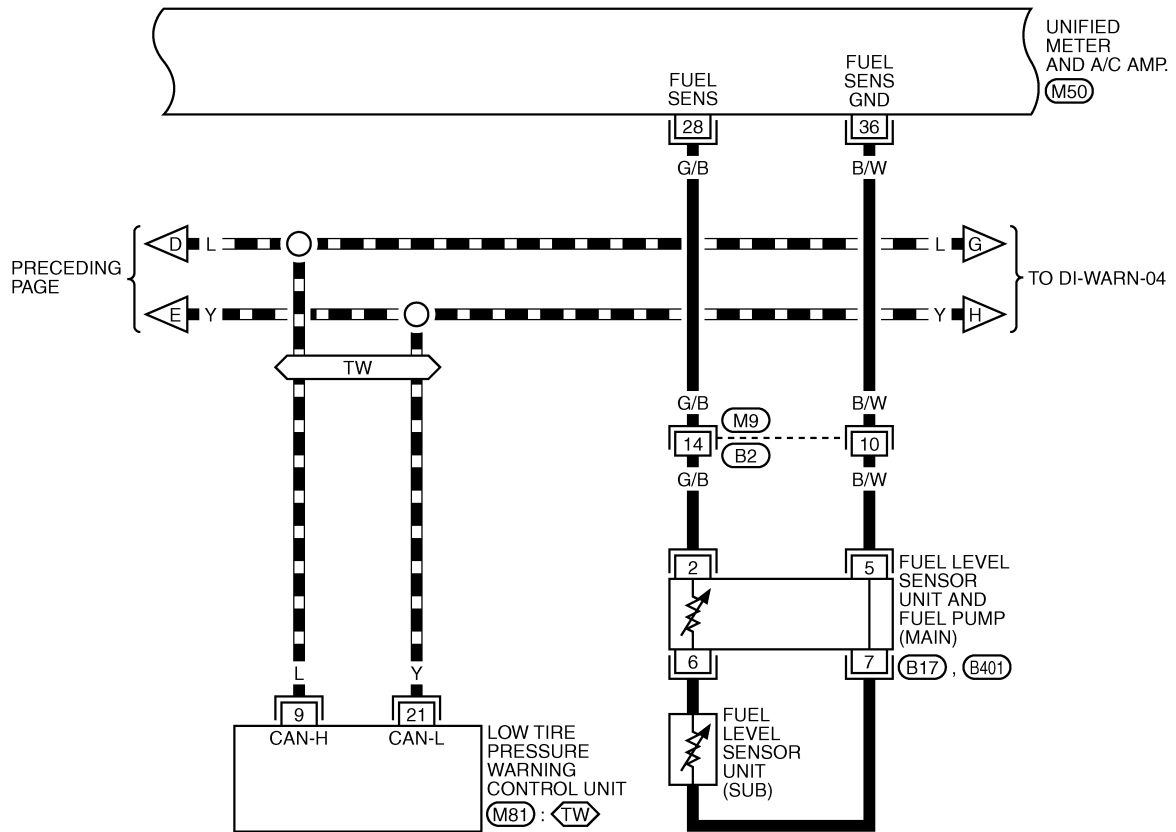
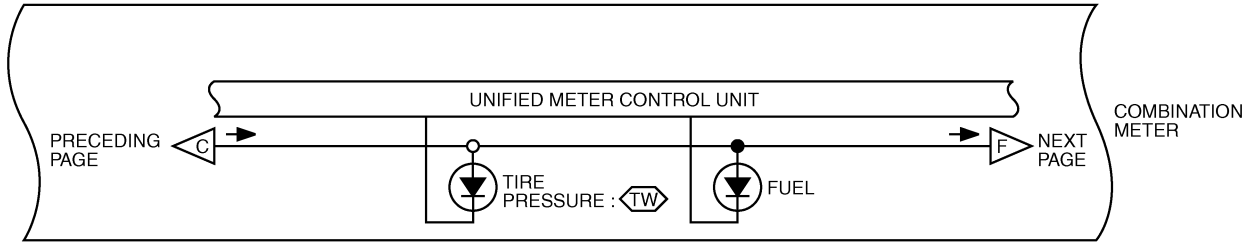

\*: THIS CONNECTOR IS NOT SHOWN IN "HARNESS LAYOUT", PG SECTION.

TKWB0484E

# WARNING LAMPS

DI-WARN-03

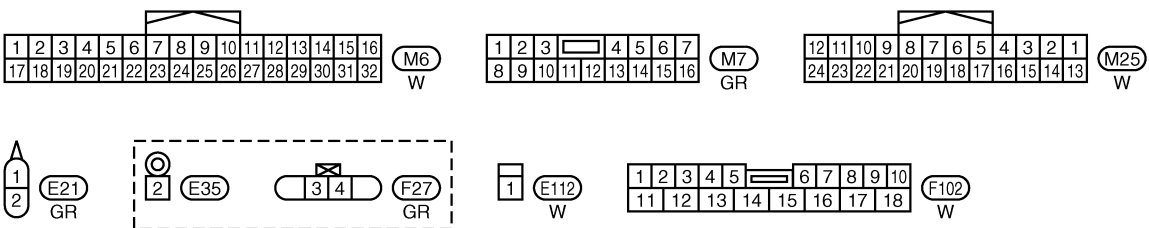
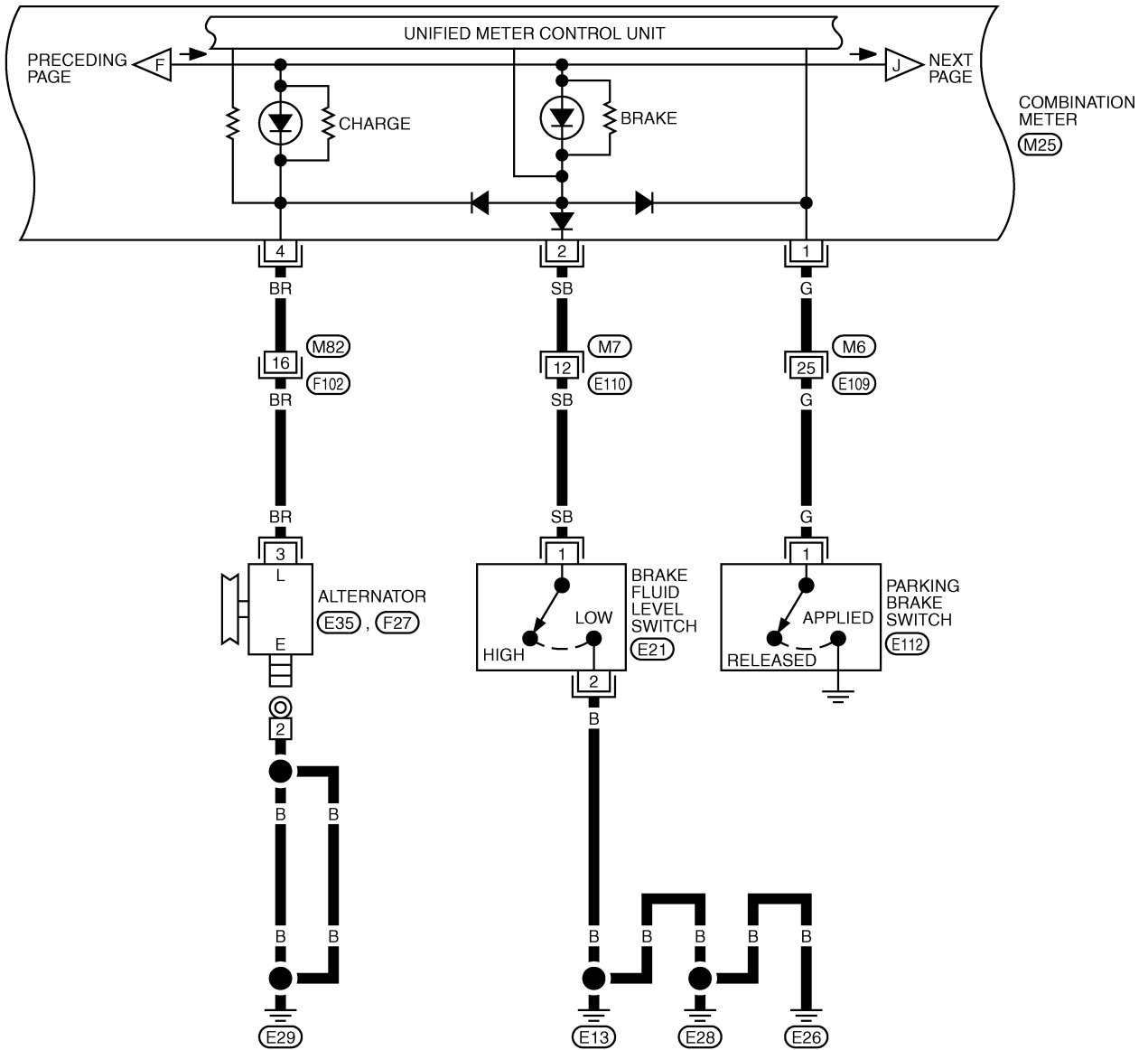

TKWB0485E

# WARNING LAMPS

DI-WARN-04

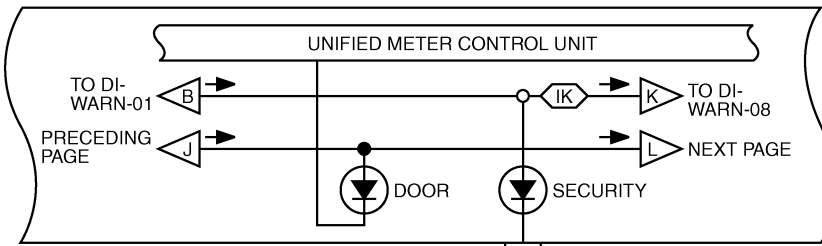

COMBINATION METER (M25)

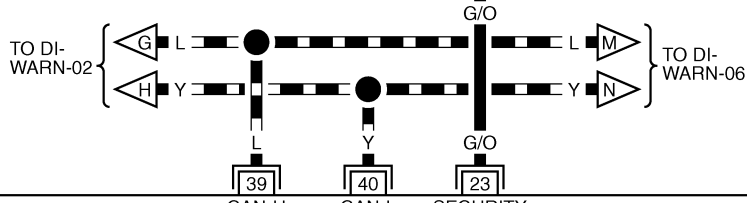

DATA LINE

IK : WITH INTELLIGENT KEY

OK : WITHOUT INTELLIGENT KEY

\*1 R/G : IK \*2 R/W : IK  
R : OK R/Y : OK

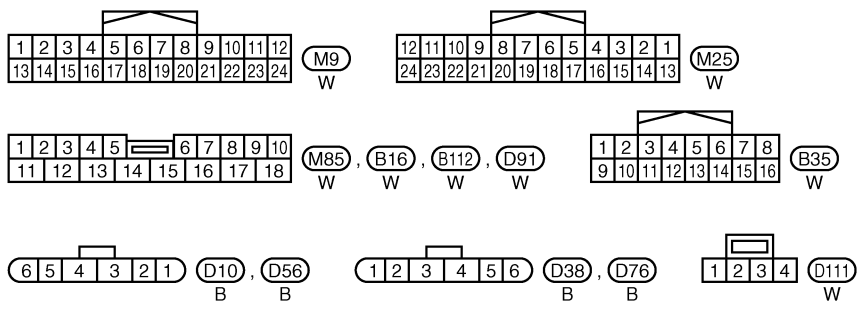
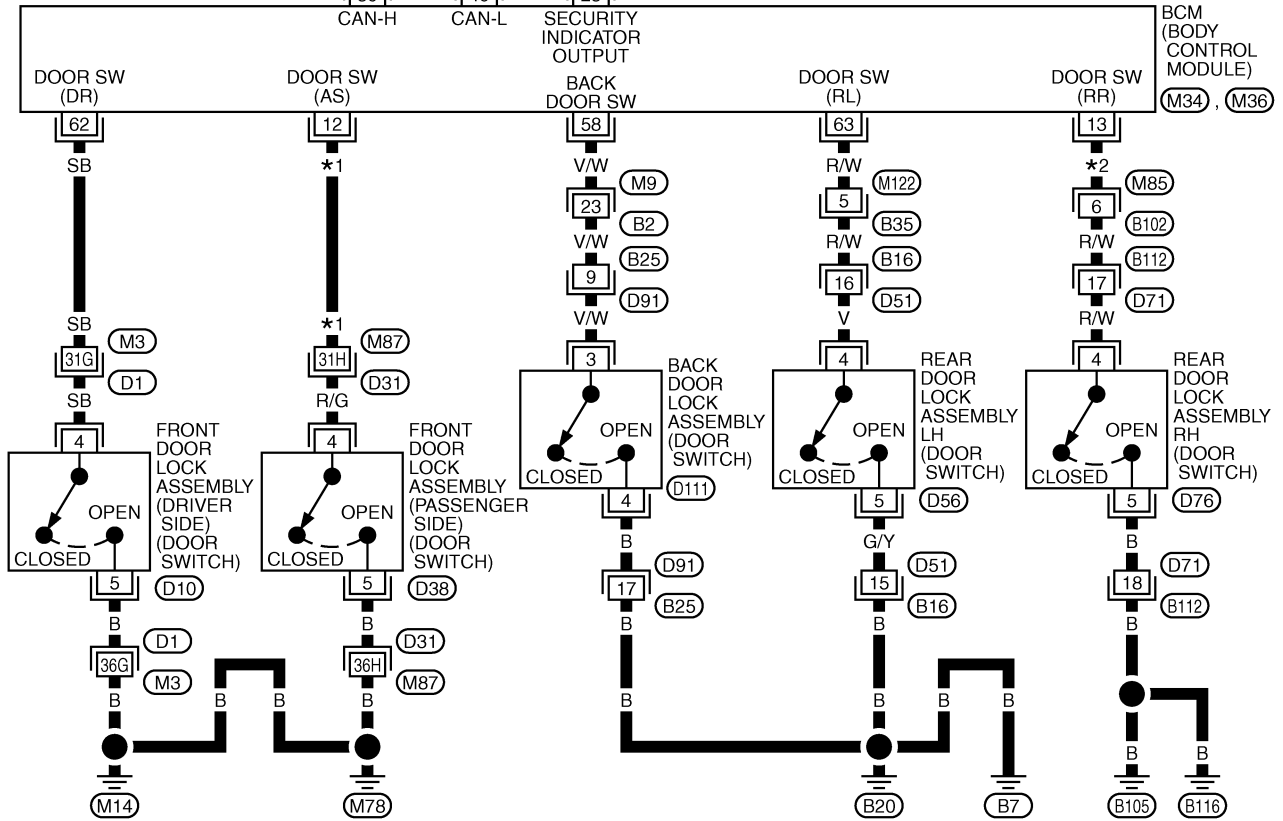

REFER TO THE FOLLOWING.

(D1), (D31) -SUPER MULTIPLE JUNCTION (SMJ)

(M34), (M36) -ELECTRICAL UNITS

TKWB0486E

# WARNING LAMPS

DI-WARN-05

A  
B  
C  
D  
E  
F  
G  
H  
I  
J  
K  
L  
M

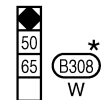
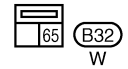
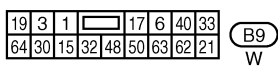
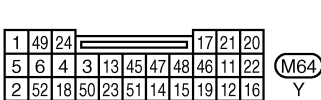
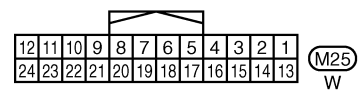
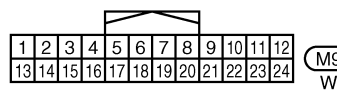
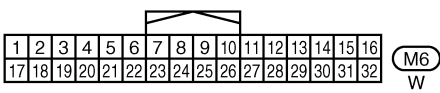
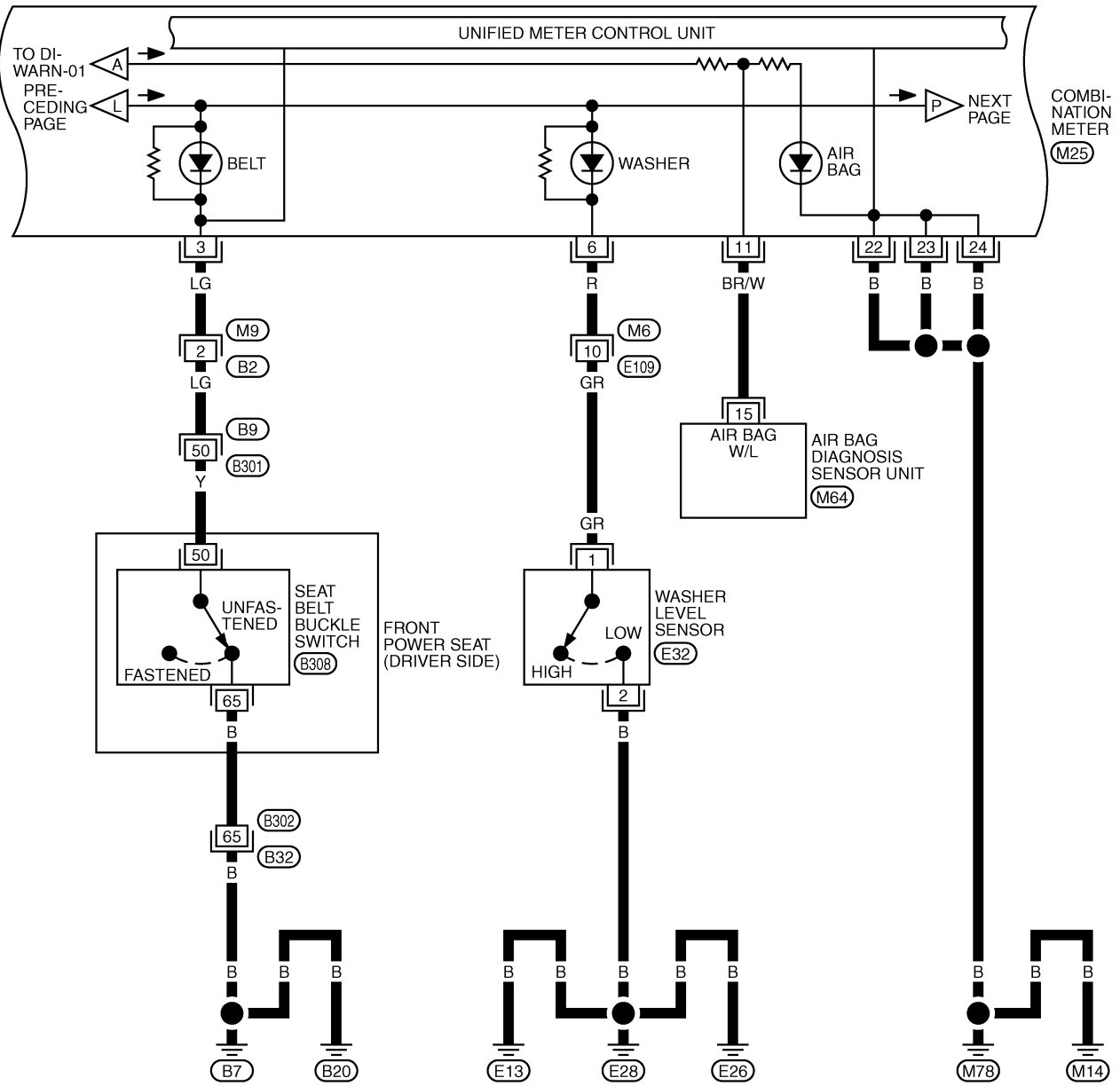

\*: THIS CONNECTOR IS NOT SHOWN IN "HARNESS LAYOUT", PG SECTION.

TKWB0487E

# WARNING LAMPS

## DI-WARN-06

▬ : DATA LINE

◊VD◊ : WITH VDC SYSTEM

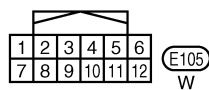
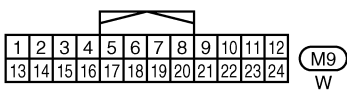
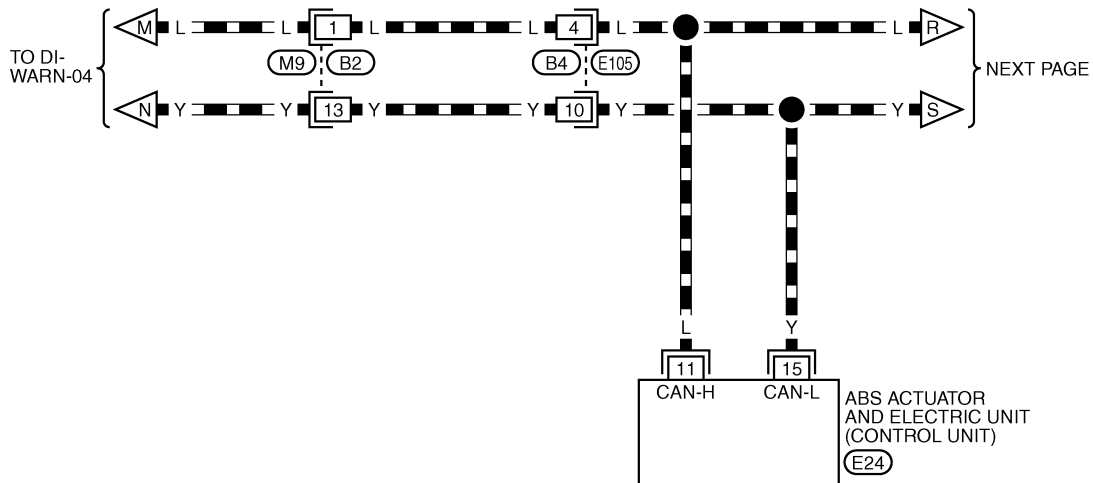
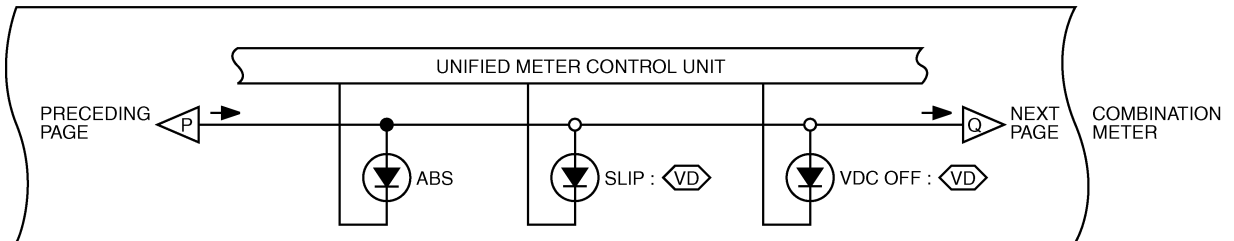

REFER TO THE FOLLOWING.

◊E24◊ -ELECTRICAL UNITS

TKWB0488E



# WARNING LAMPS

DI-WARN-07

— : DATA LINE

AW : AWD MODELS

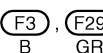
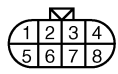
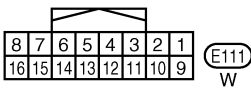
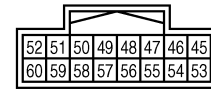
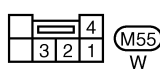
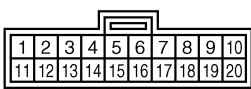
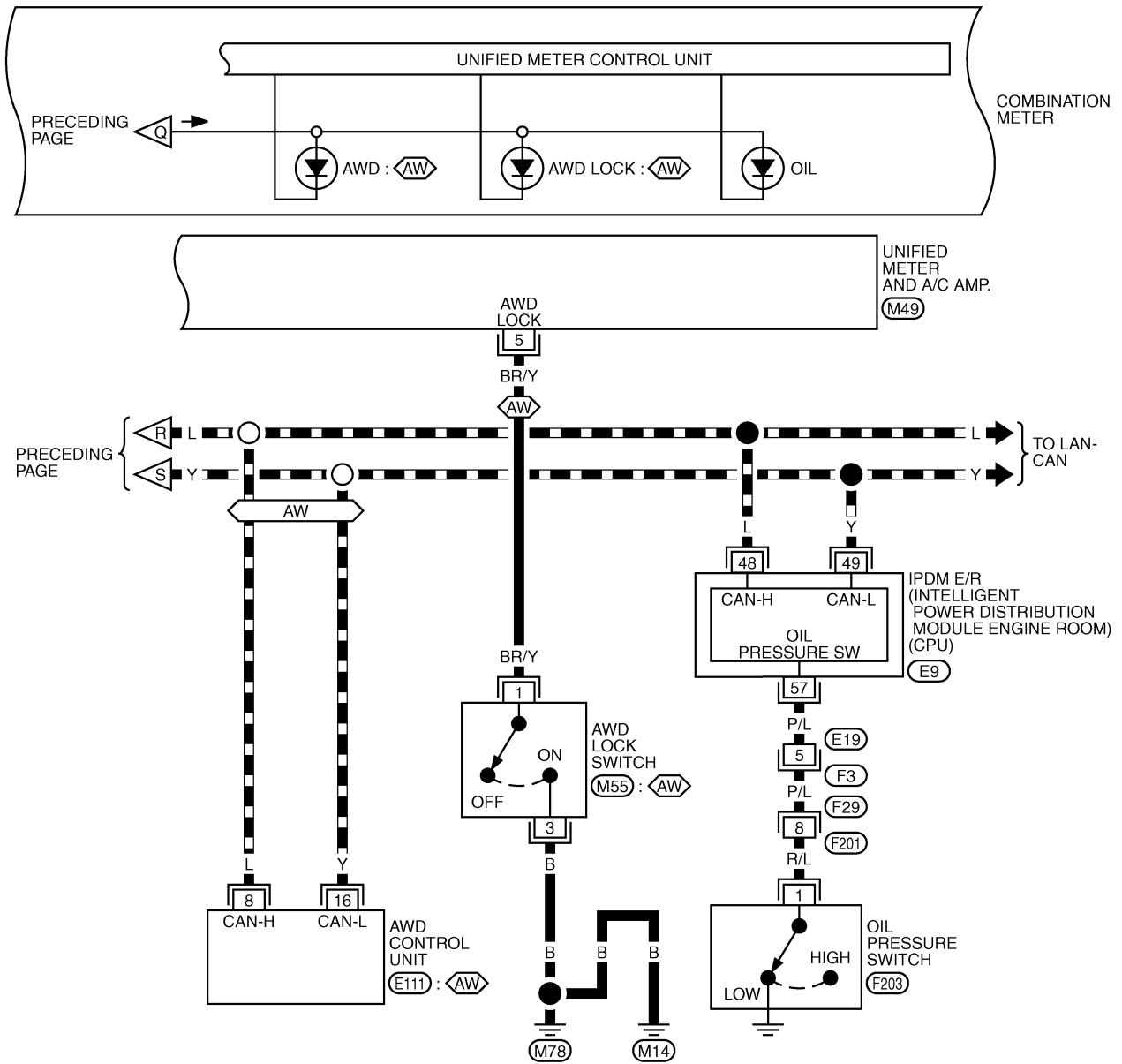

TKWB0489E

# WARNING LAMPS

DI-WARN-08

⬡IK⬢ : WITH INTELLIGENT KEY

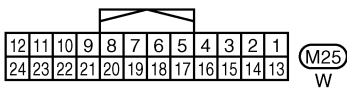
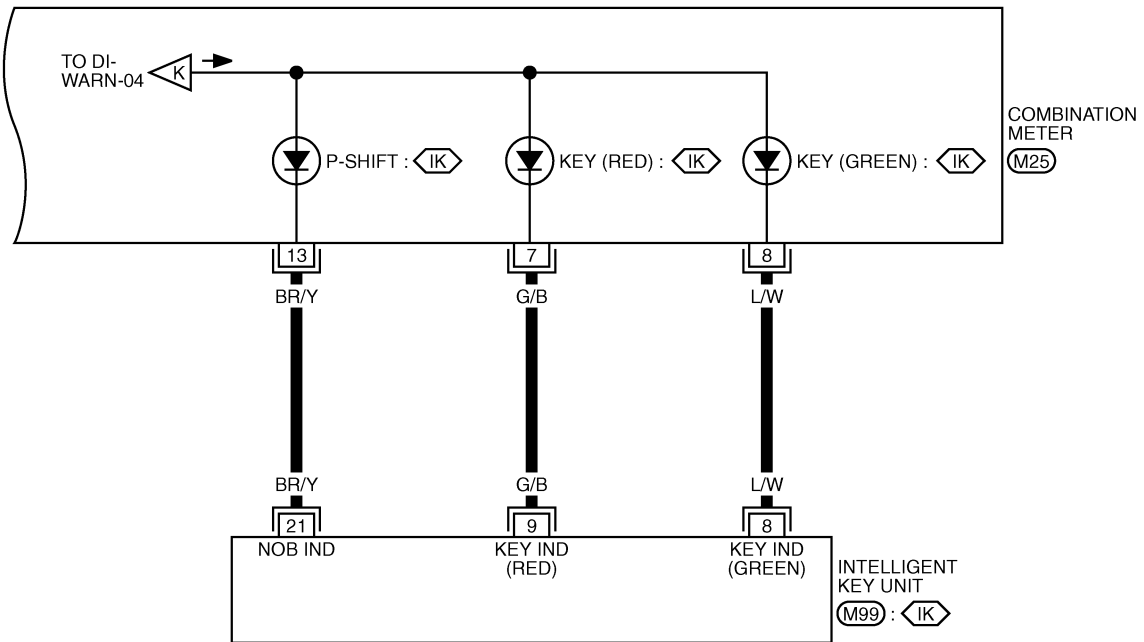

REFER TO THE FOLLOWING.  
 ⬡M99⬢ -ELECTRICAL UNITS

TKWB0490E

# WARNING LAMPS

## Oil Pressure Warning Lamp Stays Off (Ignition Switch ON)

AKS00D5N

### 1. CHECK SELF-DIAGNOSTIC RESULTS OF UNIFIED METER AND A/C AMP.

Select "METER A/C AMP" on CONSULT-II, and perform self-diagnosis of unified meter and A/C amp. Refer to [DI-31, "CONSULT-II Function \(METER A/C AMP\)"](#).

#### Self-diagnostic results content

No malfunction detected>> GO TO 2.

Malfunction detected>> Go to [DI-16, "Symptom Chart 2"](#) in "COMBINATION METER".

### 2. CHECK IPDM E/R OUTPUT SIGNAL

Activate IPDM E/R auto active test. Refer to [PG-23, "Auto Active Test"](#).

#### Does oil pressure warning lamp blink?

YES >> GO TO 5.

NO >> GO TO 3.

### 3. CHECK BCM INPUT SIGNAL

Select "DATA MONITOR" of "SIGNAL BUFFER". Refer to [BCS-13, "CONSULT-II Function \(BCM\)"](#). Operate ignition switch with "OIL PRESS SW" of "DATA MONITOR" and check operate status.

#### "OIL PRESS SW"

When ignition switch is in ON position (Engine stopped) : ON

When engine running : OFF

#### OK or NG

OK >> GO TO 4.

NG >> Replace IPDM E/R. Refer to [PG-29, "Removal and Installation of IPDM E/R"](#).

DATA MONITOR	
MONITOR	
OIL PRESS SW	ON

SKIA8709E

### 4. CHECK UNIFIED METER AND A/C AMP. INPUT SIGNAL

Select "METER A/C AMP" on CONSULT-II. Operate ignition switch with "OIL W/L" of "DATA MONITOR" and check operation status.

#### "OIL W/L"

When ignition switch is in ON position (Engine stopped) : ON

When engine running : OFF

#### OK or NG

OK >> Replace combination meter.

NG >> Replace BCM. Refer to [BCS-16, "Removal and Installation of BCM"](#).

DATA MONITOR	
MONITOR	
OIL W/L	ON

PKIA2064E

# WARNING LAMPS

## 5. CHECK OIL PRESSURE SWITCH CIRCUIT

1. Turn ignition switch OFF.
2. Disconnect IPDM E/R connector and oil pressure switch connector.
3. Check continuity between IPDM E/R harness connector E9 terminal 57 (P/L) and oil pressure switch harness connector F203 terminal 1 (R/L).

**57 (P/L) – 1 (R/L) : Continuity should exist.**

OK or NG

- OK >> GO TO 6.  
NG >> Repair harness or connector.

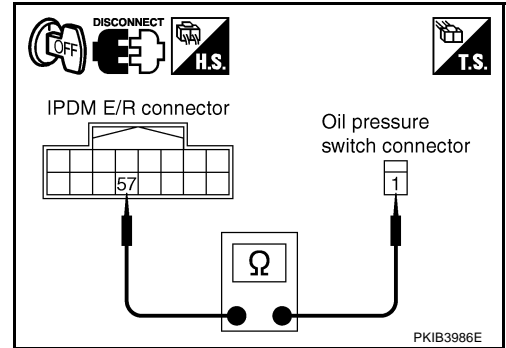

## 6. CHECK OIL PRESSURE SWITCH

Check oil pressure switch. Refer to [DI-53, "OIL PRESSURE SWITCH"](#) .

OK or NG

- OK >> Replace IPDM E/R. Refer to [PG-29, "Removal and Installation of IPDM E/R"](#) .  
NG >> Replace oil pressure switch.

## Oil Pressure Warning Lamp Does Not Turn Off (Oil Pressure Is Normal)

AKS00D50

**NOTE:**

For oil pressure inspection, refer to [LU-7, "OIL PRESSURE CHECK"](#) .

### 1. CHECK IPDM E/R OUTPUT SIGNAL

1. Turn ignition switch OFF.
2. Disconnect oil pressure switch connector.
3. Turn ignition switch ON.
4. Check voltage between oil pressure switch harness connector F203 terminal 1 (R/L) and ground.

**1 (R/L) – Ground : Approx. 12 V**

OK or NG

- OK >> GO TO 2.  
NG >> GO TO 3.

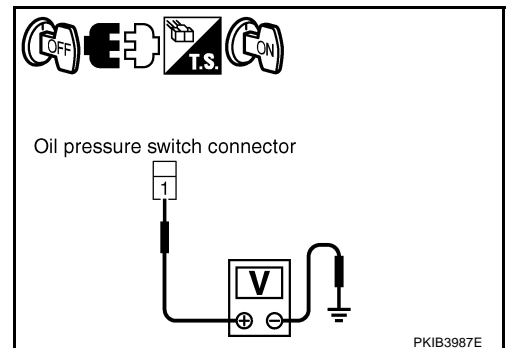

### 2. CHECK OIL PRESSURE SWITCH

1. Turn ignition switch OFF.
2. Check oil pressure switch. Refer to [DI-53, "OIL PRESSURE SWITCH"](#) .

OK or NG

- OK >> Replace IPDM E/R. Refer to [PG-29, "Removal and Installation of IPDM E/R"](#) .  
NG >> Replace oil pressure switch.

# WARNING LAMPS

## 3. CHECK OIL PRESSURE SWITCH CIRCUIT

1. Disconnect IPDM E/R connector.
2. Check continuity between IPDM E/R harness connector E9 terminal 57 (P/L) and ground.

**57 (P/L) – Ground : Continuity should not exist.**

### OK or NG

- OK >> Replace IPDM E/R. Refer to [PG-29, "Removal and Installation of IPDM E/R"](#) .
- NG >> Repair harness or connector.

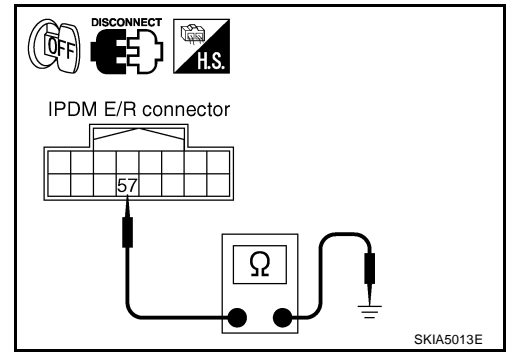

AKS00D5P

## Component Inspection OIL PRESSURE SWITCH

Check continuity between oil pressure switch and ground.

Condition	Oil pressure kPa (kg/cm <sup>2</sup> , psi)	Continuity
Engine stopped	Less than 29 (0.3, 4)	Yes
Engine running	More than 29 (0.3, 4)	No

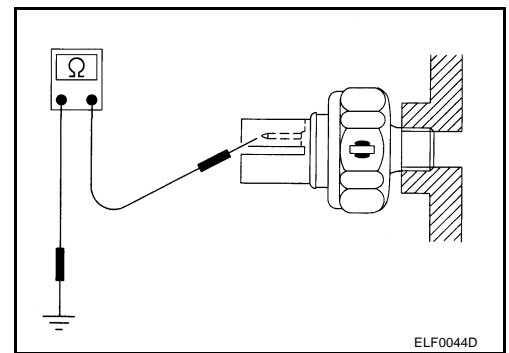

A  
B  
C  
D  
E  
F  
G  
H  
I  
J  
DI  
L  
M

DI

# CVT INDICATOR

PFP:24820

AKS00D50

## DI-CVTIND-01

▬ : DATA LINE

### CVT INDICATOR

### Wiring Diagram — CVTIND —

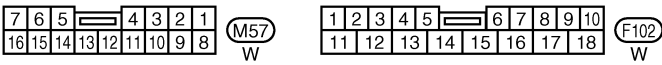
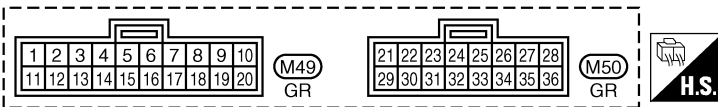
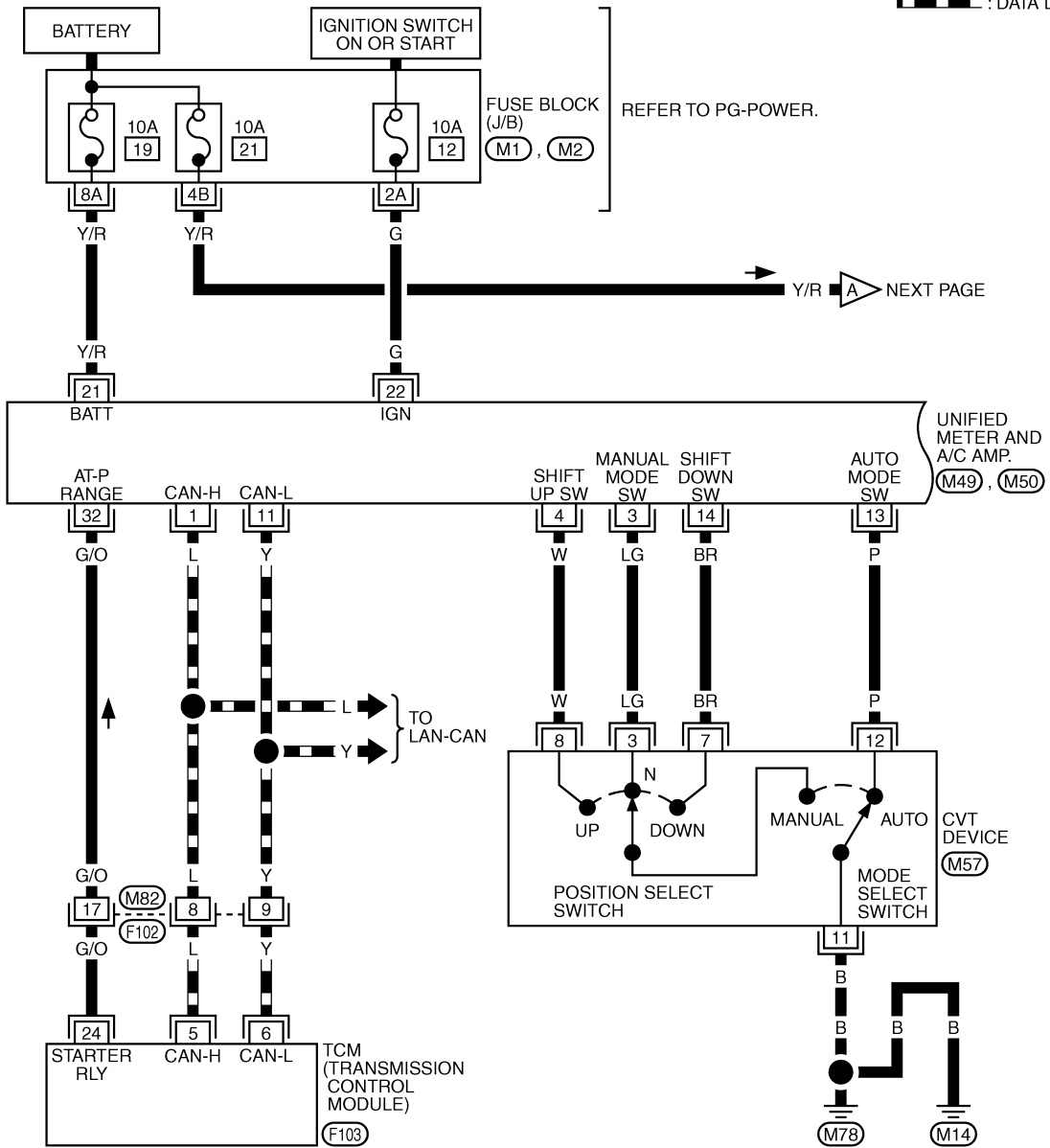

REFER TO THE FOLLOWING.

- (M1), (M2) - FUSE BLOCK-JUNCTION BOX (J/B)
- (F103) - ELECTRICAL UNITS

TKWB0103E

# CVT INDICATOR

DI-CVTIND-02

A  
B  
C  
D  
E  
F  
G  
H  
I  
J  
K  
L  
M

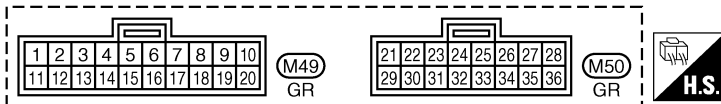
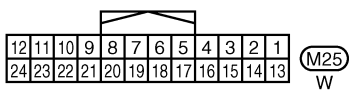
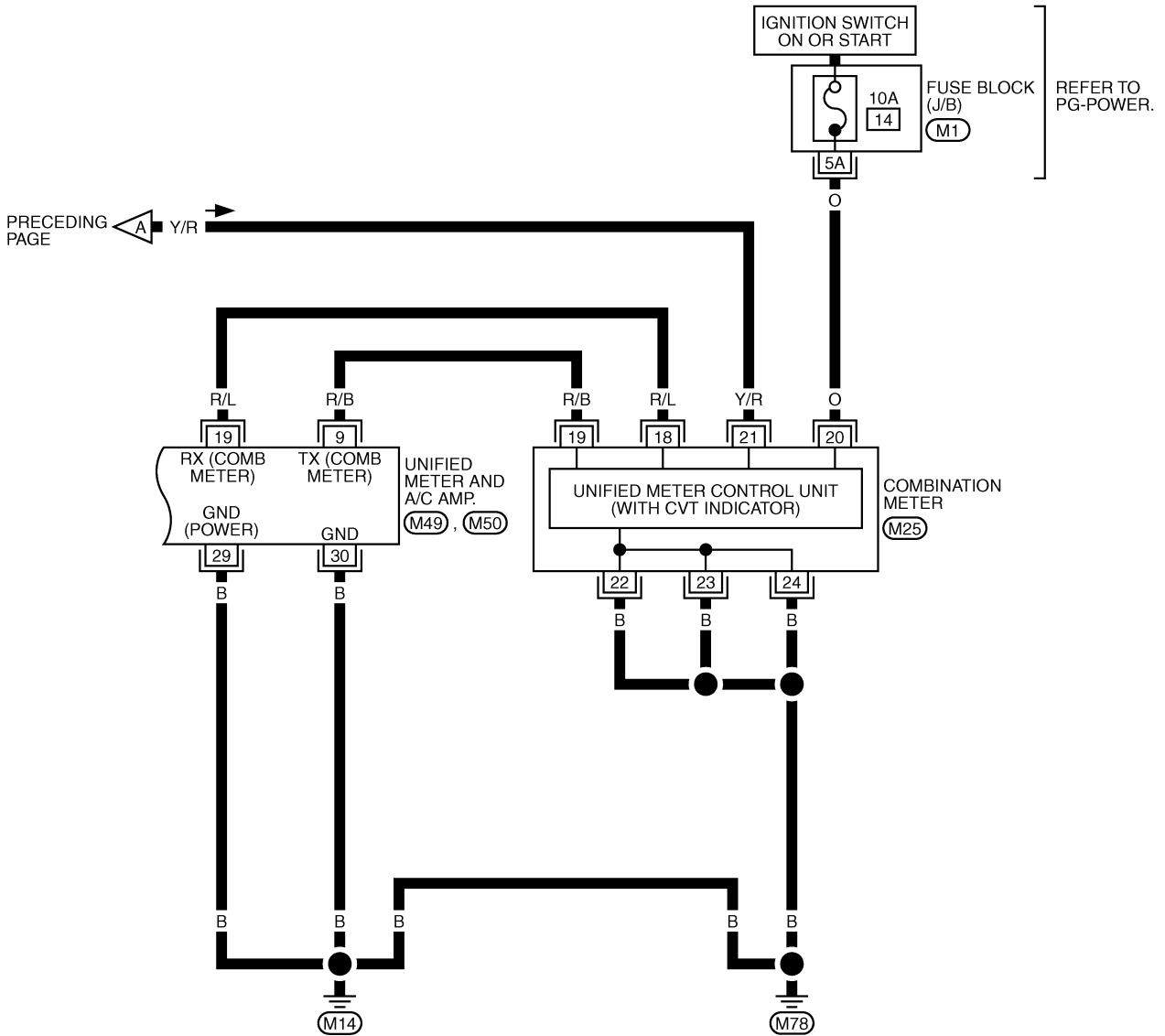

REFER TO THE FOLLOWING.  
 (M1) -FUSE BLOCK-JUNCTION BOX (J/B)

TKWB0104E

# CVT INDICATOR

DI-CVTIND-03

▬ : DATA LINE

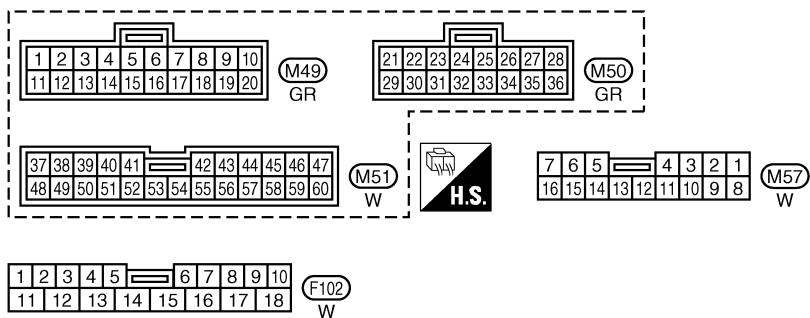
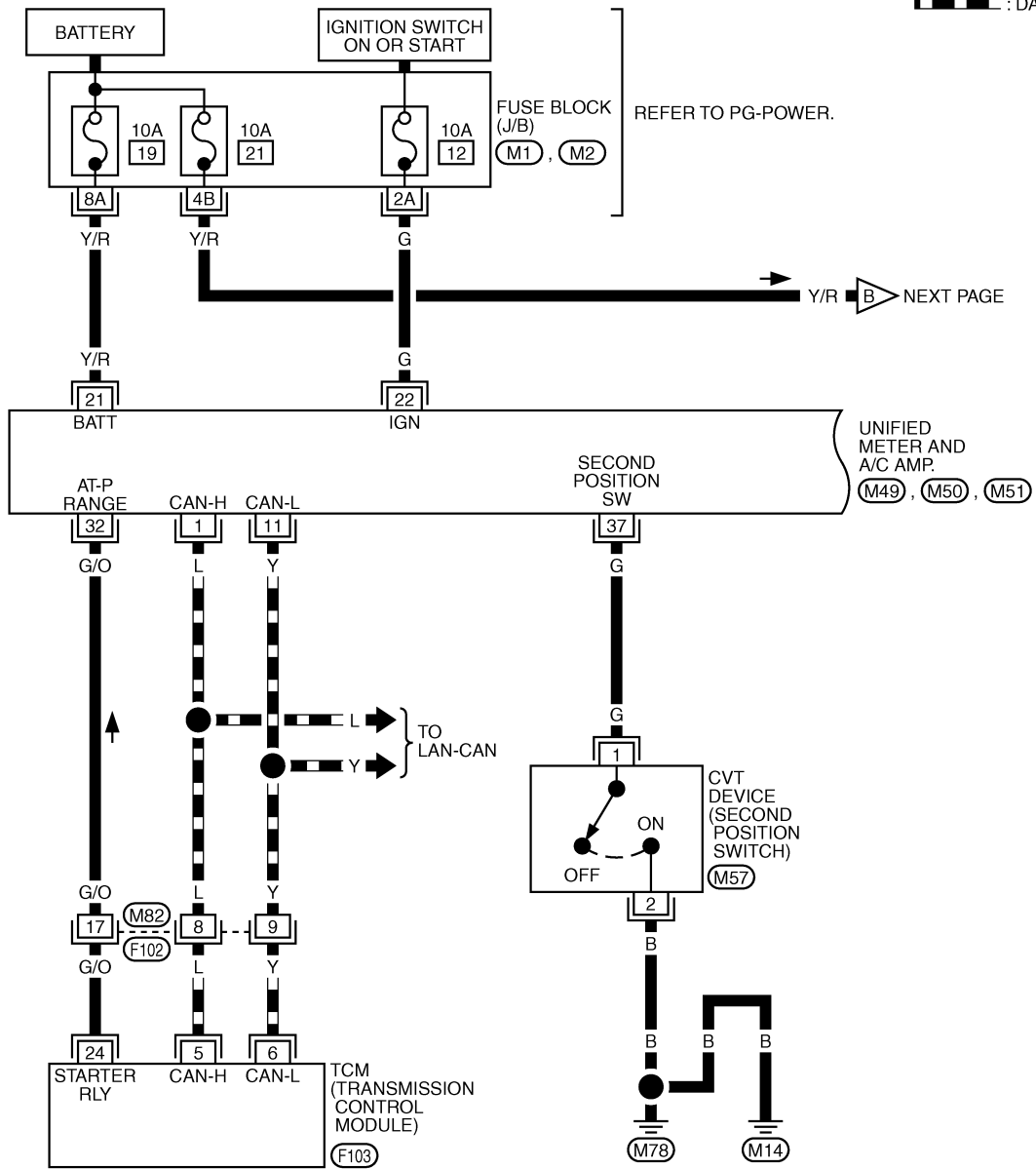

REFER TO THE FOLLOWING.

(M1), (M2) - FUSE BLOCK-JUNCTION BOX (J/B)

(F103) - ELECTRICAL UNITS

TKWB0123E



# CVT INDICATOR

DI-CVTIND-04

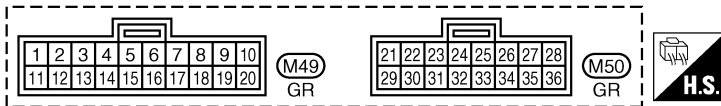
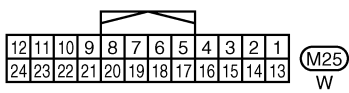
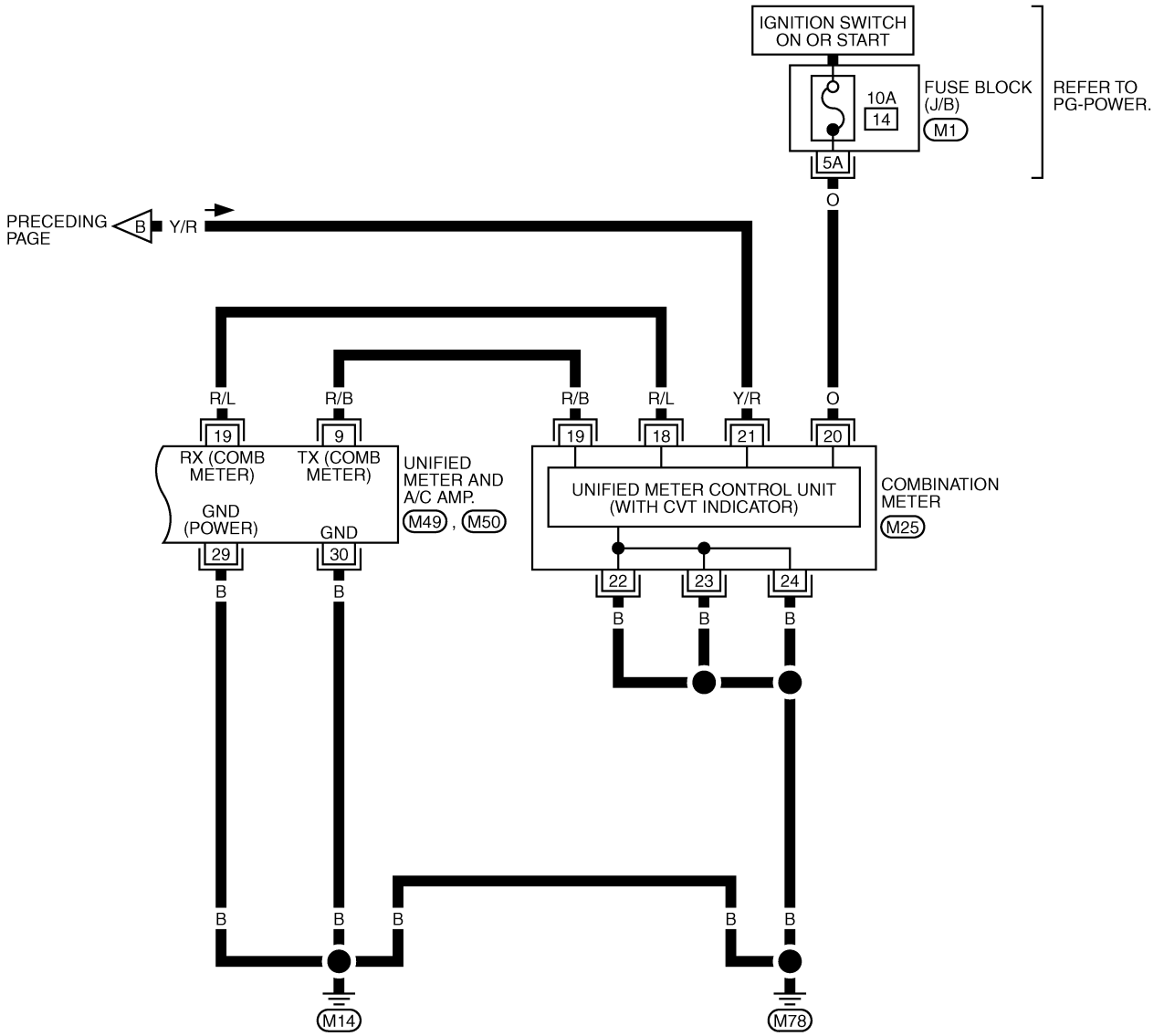

REFER TO THE FOLLOWING.  
 (M1) - FUSE BLOCK-JUNCTION BOX (J/B)

TKWB0124E

# CVT INDICATOR

AKS00D5R

## CVT Indicator Is Malfunction

### 1. CHECK SELF-DIAGNOSIS OF COMBINATION METER

Perform combination meter self-diagnosis. Refer to [DI-14, "OPERATION PROCEDURE"](#).

Are all segments displayed?

- YES >> GO TO 2.
- NO >> Replace combination meter.

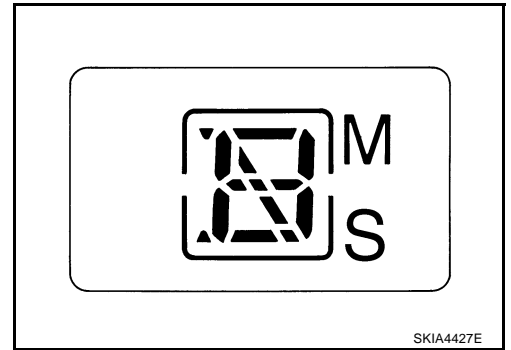

### 2. CHECK SELF-DIAGNOSTIC RESULTS OF UNIFIED METER AND A/C AMP.

Select "METER A/C AMP" on CONSULT-II, and perform self-diagnosis of unified meter and A/C amp. Refer to [DI-31, "CONSULT-II Function \(METER A/C AMP\)"](#).

Self-diagnostic results content

- No malfunction detected>> GO TO 3 (With manual mode) or GO TO 4 (Without manual mode).
- Malfunction detected>> Go to [DI-16, "Symptom Chart 2"](#) in "COMBINATION METER".

### 3. CHECK UNIFIED METER AND A/C AMP. INPUT SIGNAL

1. Connect CONSULT-II and start engine.
2. Use "DATA MONITOR" of "METER A/C AMP" on CONSULT-II. Confirm each indication on the monitor when operating the shift lever.

CONSULT-II display	Switch operation	Operation status
AT-M IND	Manual mode range	ON
	Except for manual mode range	OFF
AT-M GEAR	Manual mode range (shift-up or down)	5-1
	Except for manual mode range	1
P RANGE IND	P range position	ON
	Except for P range position	OFF
R RANGE IND	R range position	ON
	Except for R range position	OFF
N RANGE IND	N range position	ON
	Except for N range position	OFF
D RANGE IND	D range position	ON
	Except for D range position	OFF

DATA MONITOR	
MONITOR	
AT-M IND	OFF
AT-M GEAR	1
P RANGE IND	ON
R RANGE IND	OFF
N RANGE IND	OFF
D RANGE IND	OFF

SKIA6259E

OK or NG

- OK >> Replace combination meter.
- NG >> GO TO 5.

# CVT INDICATOR

## 4. CHECK UNIFIED METER AND A/C AMP. INPUT SIGNAL

1. Connect CONSULT-II and start engine.
2. Use "DATA MONITOR" of "METER A/C AMP" on CONSULT-II. Confirm each indication on the monitor when operating the shift lever.

DATA MONITOR	
MONITOR	
AT-M IND	OFF
AT-M GEAR	1
P RANGE IND	ON
R RANGE IND	OFF
N RANGE IND	OFF
D RANGE IND	OFF
L RANGE IND	OFF
S RANGE IND	OFF

PKIA2499E

CONSULT-II display	Switch operation	Operation status
AT-M IND	–	OFF
AT-M GEAR	–	1
P RANGE IND	P range position	ON
	Except for P range position	OFF
R RANGE IND	R range position	ON
	Except for R range position	OFF
N RANGE IND	N range position	ON
	Except for N range position	OFF
D RANGE IND	D range position	ON
	Except for D range position	OFF
L RANGE IND	L range position	ON
	Except for L range position	OFF
S RANGE IND	S range position	ON
	Except for S range position	OFF

### OK or NG

- OK >> Replace combination meter.  
 NG >> GO TO 5.

## 5. CHECK CVT DEVICE

Check the following.

- CVT device (Manual mode switch) inspection. Refer to [CVT-135, "DTC P0826 MANUAL MODE SWITCH CIRCUIT"](#) (With manual mode).
- CVT device (Second position switch). Refer to [CVT-181, "SECOND POSITION SWITCH"](#) (Without manual mode).

### OK or NG

- OK >> GO TO 6.  
 NG >> Repair corresponding parts.

## 6. CHECK TCM

Check TCM input/output signal. Refer to [CVT-58, "TCM Input/Output Signal Reference Values"](#) .

### OK or NG

- OK >> Replace the unified meter and A/C amp. Refer to [DI-37, "Removal and Installation of Unified Meter and A/C Amp."](#) .  
 NG >> Check applicable parts, and repair or replace corresponding parts.

# WARNING CHIME

## WARNING CHIME

PFP:24814

### System Description FUNCTION

AKS00D5S

Power is supplied at all times

- through 50A fusible link (letter **F** , located in the fuse and fusible link block)
- to BCM terminal 55,
- through 10A fuse [No. 18, located in the fuse block (J/B)]
- to BCM terminal 42,
- through 10A fuse [No. 21, located in the fuse block (J/B)]
- to key switch terminal 3 (without Intelligent Key), and
- to combination meter terminal 21,
- through 10A fuse [No. 22, located in the fuse block (J/B)]
- to key switch and ignition knob switch terminals 1 and 3 (with Intelligent Key),
- through 10A fuse [No. 19, located in the fuse block (J/B)]
- to unified meter and A/C amp. terminal 21.

When ignition switch ON or START position, power is supplied

- through 10A fuse [No. 1, located in the fuse block (J/B)]
- to BCM terminal 38,
- through 10A fuse [No. 12, located in the fuse block (J/B)]
- to unified meter and A/C amp. terminal 22,
- through 10A fuse [No. 14, located in the fuse block (J/B)]
- to combination meter terminal 20.

Ground is supplied

- to BCM terminal 52
- through grounds E13, E26 and E28,
- to unified meter and A/C amp. terminals 29 and 30
- through grounds M14 and M78,
- to combination meter terminals 22, 23 and 24
- through grounds M14 and M78.

#### NOTE:

When ignition key warning chime, light warning chime, and seat belt warning chime should be conducted at the same time, the priorities for each chime are the following.

1. Light warning chime
2. Ignition key warning chime
3. Seat belt warning chime

### IGNITION KEY WARNING CHIME (WITHOUT INTELLIGENT KEY)

With the key inserted into the ignition switch, and the driver's door is opened, the warning chime will sound.

Power is supplied

- through key switch terminal 4
- to BCM terminal 37.

Ground is supplied

- through BCM terminal 62
- to driver side door switch terminal 4.

Driver side door switch terminal 5 is grounded through grounds M14 and M78.

BCM detects key inserted into the ignition switch, and sends key warning signal to unified meter and A/C amp. with CAN communication line. Unified meter and A/C amp. sends key warning signal to combination meter with communication line between unified meter and A/C amp. and combination meter.

When combination meter receives key warning signal, it sounds warning chime.

# WARNING CHIME

## IGNITION KEY WARNING CHIME (WITH INTELLIGENT KEY)

### When Mechanical Key Is Used

With the key inserted into the ignition switch, and the ignition switch LOCK or ACC, when driver's door is opened, the warning chime will sound.

Power is supplied

- through key switch and ignition knob switch terminal 4
- to BCM terminal 37.

Ground is supplied

- through BCM terminal 62
- to driver side door switch terminal 4.

Driver side door switch terminal 5 is grounded through grounds M14 and M78.

BCM detects key inserted into the ignition switch, and sends key warning signal to unified meter and A/C amp. with CAN communication line. Unified meter and A/C amp. sends key warning signal to combination meter with communication line between unified meter and A/C amp. and combination meter.

When combination meter receives key warning signal, it sounds warning chime.

### When Intelligent Key Is Carried With The Driver

Intelligent Key unit detects ignition knob return is forgotten, and sends key warning signal to Intelligent Key buzzer.

When Intelligent Key buzzer receives key warning signal, it sounds warning chime.

Refer to [BL-99, "WARNING CHIME FUNCTION"](#) .

## LIGHT WARNING CHIME

With the key removed from the ignition switch, the driver's door is opened, and the lighting switch in 1st or 2nd position, the warning chime will sound. [Except when headlamp battery saver control operates (for 5 minutes after ignition switch is turned to OFF or ACC position) and headlamps do not illuminate.]

Signal is supplied

- from combination switch (lighting switch) terminals 1, 2, 3, 4, 5, 6, 7, 8, 9 and 10
- to BCM terminals 2, 3, 4, 5, 6, 32, 33, 34, 35 and 36.

#### NOTE:

BCM detected lighting switch in 1st or 2nd position, refer to [LT-143, "Combination Switch Reading Function"](#) .

Ground is supplied

- through BCM terminal 62
- to driver side door switch terminal 4.

Driver side door switch terminal 5 is grounded through grounds M14 and M78.

BCM detects headlamps are illuminated, and sends light warning signal to unified meter and A/C amp. with CAN communication line. Unified meter and A/C amp. sends light warning signal to combination meter with communication line between unified meter and A/C amp. and combination meter.

When combination meter receives light warning signal, it sounds warning chime.

## SEAT BELT WARNING CHIME

With ignition switch turned ON and seat belt unfastened [seat belt buckle switch (driver side) ON], warning chime will sound for approximately 6 seconds.

Ground is supplied

- to combination meter terminal 3
- through seat belt buckle switch (driver side) terminal 50.

Seat belt buckle switch (driver side) terminal 65 is grounded through grounds B7 and B20.

Combination meter sends seat belt unfastened [seat belt buckle switch (driver side) ON] signal to unified meter and A/C amp. with communication line between unified meter and A/C amp. and combination meter.

BCM receives seat belt unfastened [seat belt buckle switch (driver side) ON] signal from unified meter and A/C amp. with CAN communication line, and sends seat belt warning signal to unified meter and A/C amp. with CAN communication line. Unified meter and A/C amp. sends seat belt warning signal to combination meter with communication line between unified meter and A/C amp. and combination meter.

When combination meter receives seat belt warning signal, it sounds warning chime.

A  
B  
C  
D  
E  
F  
G  
H  
I  
J  
DI  
L  
M

# WARNING CHIME

## CAN Communication System Description

AKS00D5T

CAN (Controller Area Network) is a serial communication line for real time application. It is an on-vehicle multiplex communication line with high data communication speed and excellent error detection ability. Many electronic control units are equipped onto a vehicle, and each control unit shares information and links with other control units during operation (not independent). In CAN communication, control units are connected with 2 communication lines (CAN H line, CAN L line) allowing a high rate of information transmission with less wiring. Each control unit transmits/receives data but selectively reads required data only.

## CAN Communication Unit

AKS00D5U

Refer to [LAN-29. "CAN Communication Unit"](#) in "LAN SYSTEM".

## Component Parts and Harness Connector Location

AKS00D5V

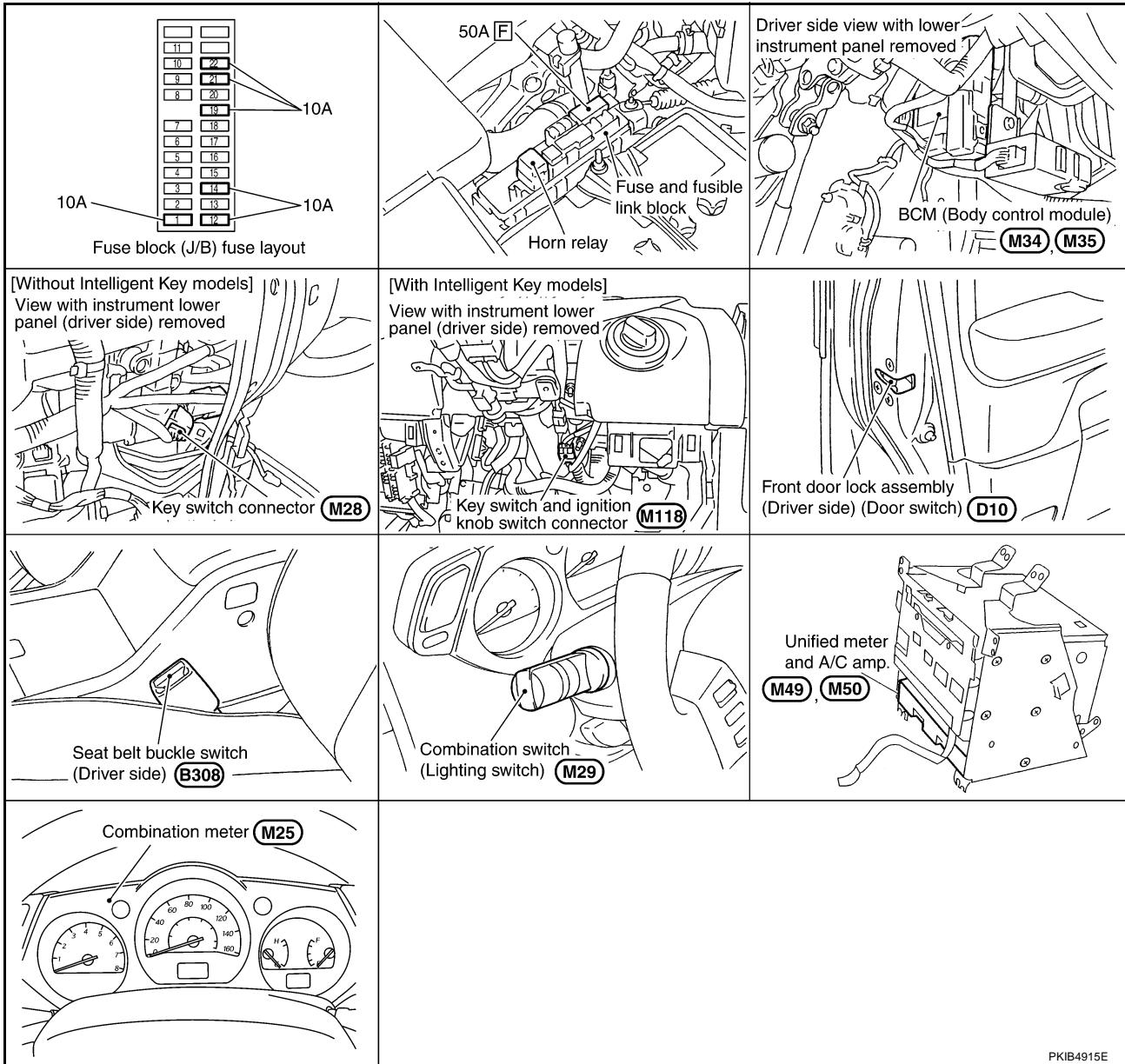

PKIB4915E

# WARNING CHIME

## Schematic

AKS00D5W

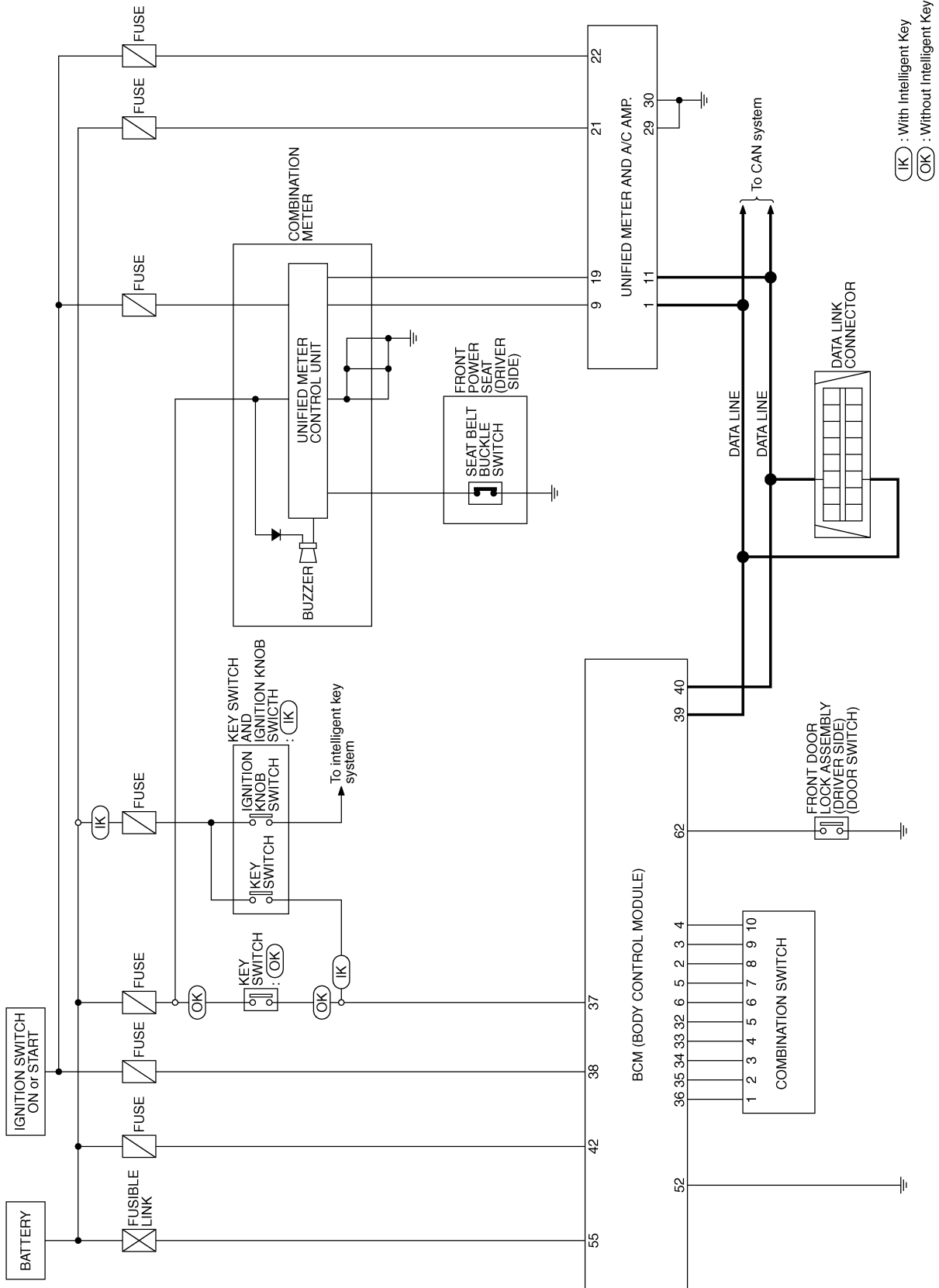

TKWB0491E

A  
B  
C  
D  
E  
F  
G  
H  
I  
J  
DI  
L  
M

# WARNING CHIME

AKS00D5X

## Wiring Diagram — CHIME —

### DI-CHIME-01

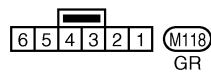
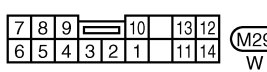
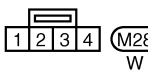
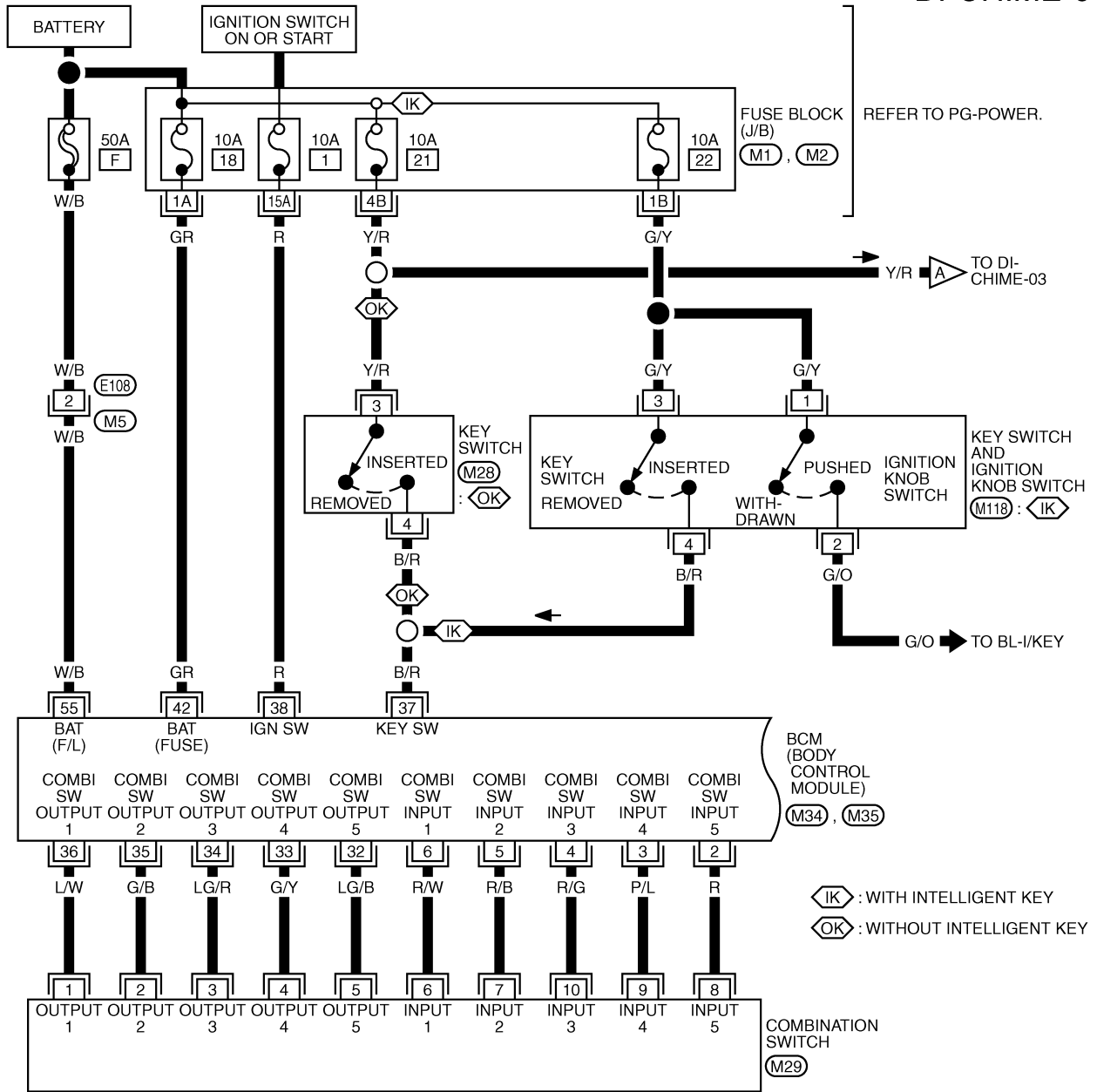

REFER TO THE FOLLOWING.

(M1), (M2) - FUSE BLOCK-JUNCTION BOX (J/B)

(M34), (M35) - ELECTRICAL UNITS

TKWB0492E



# WARNING CHIME

DI-CHIME-02

A  
B  
C  
D  
E  
F  
G  
H  
I  
J  
K  
L  
M

▬ : DATA LINE

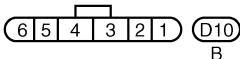
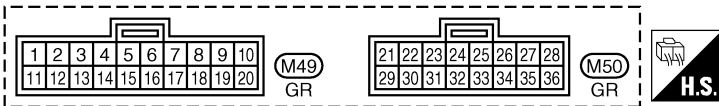
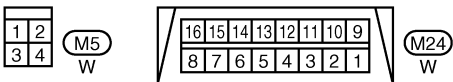
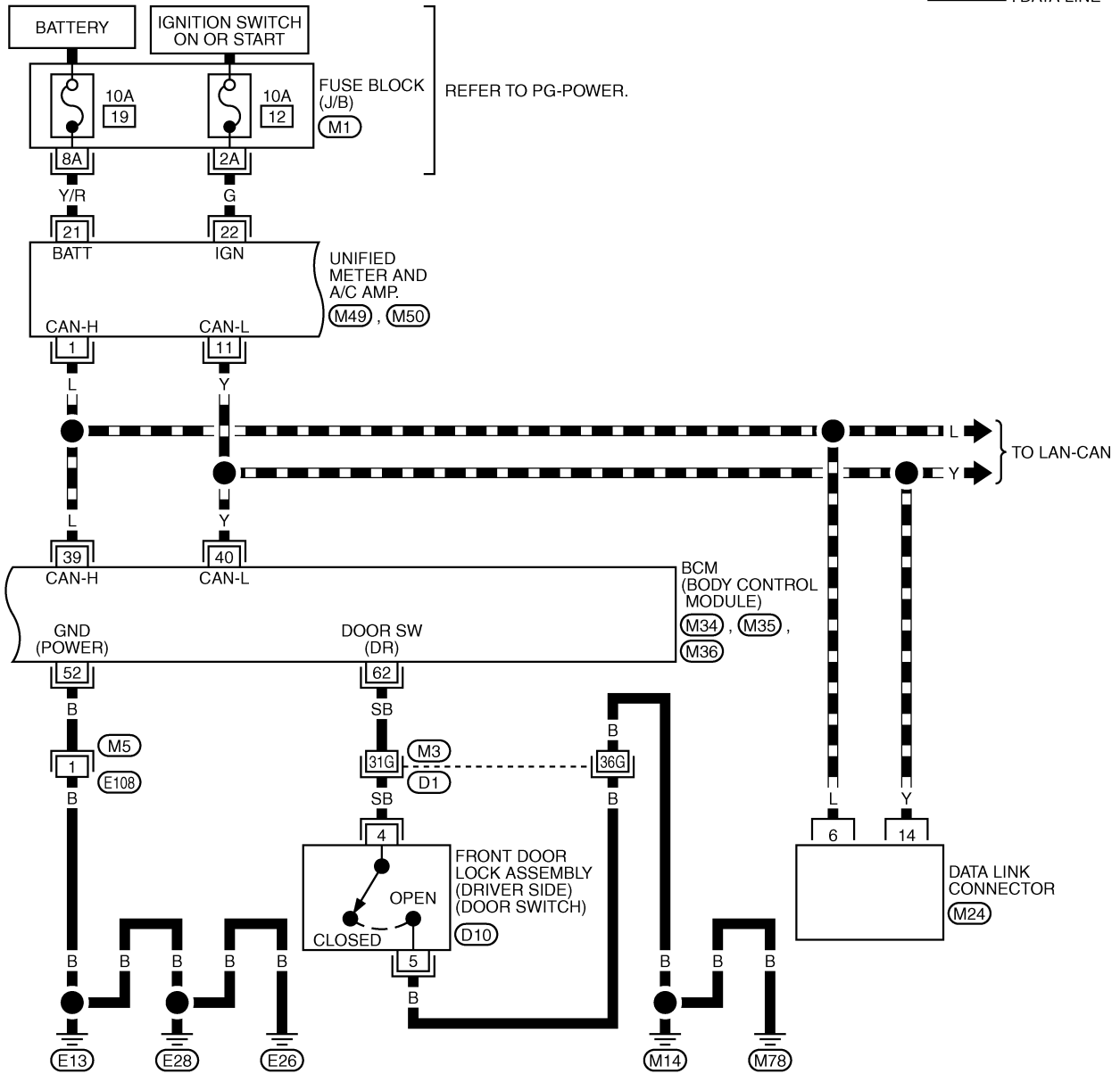

REFER TO THE FOLLOWING.

- (D1) -SUPER MULTIPLE JUNCTION (SMJ)
- (M1) -FUSE BLOCK-JUNCTION BOX (J/B)
- (M34), (M35), (M36) -ELECTRICAL UNITS

TKWB0493E

# WARNING CHIME

## DI-CHIME-03

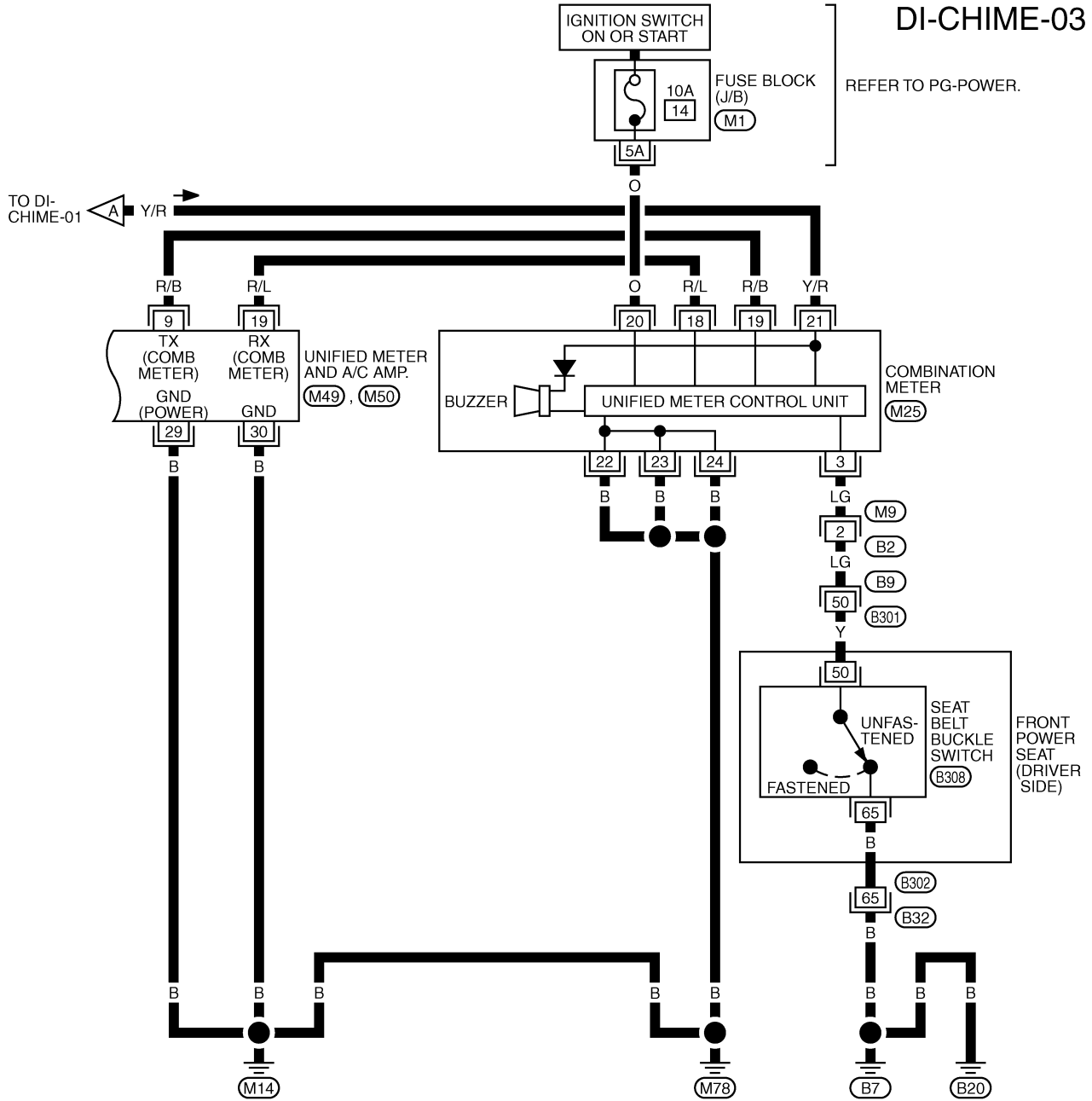

REFER TO PG-POWER.

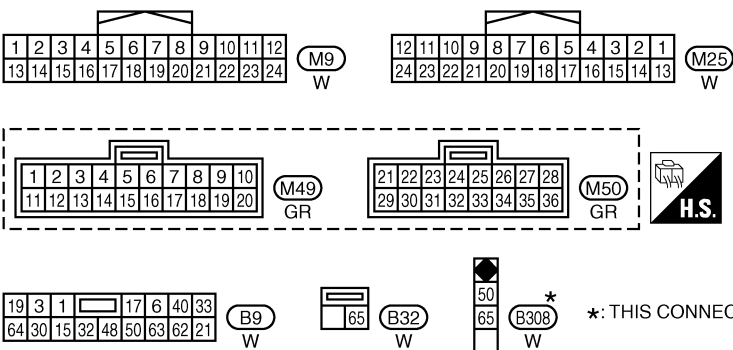

REFER TO THE FOLLOWING.  
 (M1) - FUSE BLOCK-JUNCTION BOX (J/B)





\*: THIS CONNECTOR IS NOT SHOWN IN "HARNESS LAYOUT", PG SECTION.

TKWB0494E

# WARNING CHIME

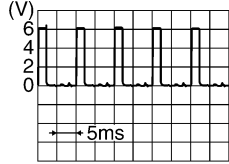
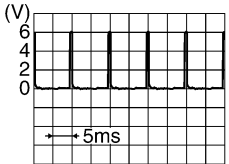
## Terminals and Reference Value for BCM

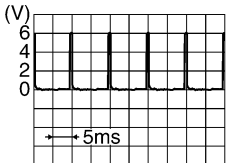
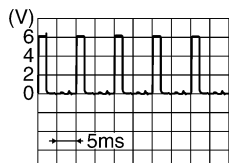
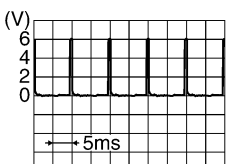
AKS00D5Y

Terminal No.	Wire color	Signal name	Measuring condition		Reference value (V)
			Ignition switch	Operation or condition	
2	R	Combination switch input 5	ON	Lighting, turn, wiper OFF Wiper dial position 4	 <p style="text-align: right;">SKIA5291E</p>
3	P/L	Combination switch input 4	ON	Lighting, turn, wiper OFF Wiper dial position 4	 <p style="text-align: right;">SKIA5292E</p>
4	R/G	Combination switch input 3	ON	Lighting, turn, wiper OFF Wiper dial position 4	 <p style="text-align: right;">SKIA5291E</p>
5	R/B	Combination switch input 2	ON	Lighting, turn, wiper OFF Wiper dial position 4	 <p style="text-align: right;">SKIA5292E</p>
6	R/W	Combination switch input 1			
32	LG/B	Combination switch output 5	ON	Lighting, turn, wiper OFF Wiper dial position 4	 <p style="text-align: right;">SKIA5291E</p>
33	G/Y	Combination switch output 4	ON	Lighting, turn, wiper OFF Wiper dial position 4	 <p style="text-align: right;">SKIA5292E</p>
34	LG/R	Combination switch output 3	ON	Lighting, turn, wiper OFF Wiper dial position 4	 <p style="text-align: right;">SKIA5291E</p>

A  
B  
C  
D  
E  
F  
G  
H  
I  
J  
DI  
L  
M

# WARNING CHIME

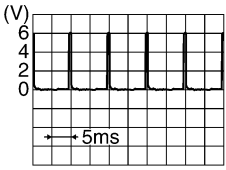
Terminal No.	Wire color	Signal name	Measuring condition		Reference value (V)
			Ignition switch	Operation or condition	
35	G/B	Combination switch output 2	ON	Lighting, turn, wiper OFF Wiper dial position 4	 <small>SKIA5292E</small>
36	L/W	Combination switch output 1			
37	B/R	Key switch signal	OFF	Key is removed.	Approx. 0
				Key is inserted.	Approx. 12
38	R	Ignition switch ON or START	ON	—	Battery voltage
39	L	CAN H	—	—	—
40	Y	CAN L	—	—	—
42	GR	Battery power supply	OFF	—	Battery voltage
52	B	Ground (Power)	ON	—	Approx. 0
55	W/B	Battery power supply (F/L)	OFF	—	Battery voltage
62	SB	Driver side door switch signal	OFF	ON (open)	Approx. 0
				OFF (closed)	Approx. 12

## Terminals and Reference Value for Unified Meter and A/C Amp.

AKS00D5Z

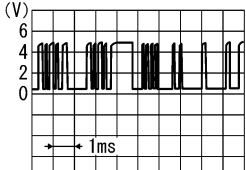
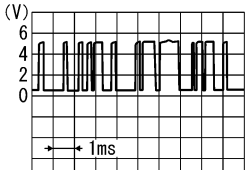
Terminal No.	Wire color	Item	Measuring or condition		Reference value (V)
			Ignition switch	Operation or condition	
1	L	CAN H	OFF	—	—
9	R/B	TX communication line (To combination meter)	ON	—	 <small>SKIA3362E</small>
11	Y	CAN L	OFF	—	—
19	R/L	RX communication line (From combination meter)	ON	—	 <small>SKIA3361E</small>
21	Y/R	Battery power supply	OFF	—	Battery voltage
22	G	Ignition switch ON or START	ON	—	Battery voltage
29	B	Ground (power)	ON	—	Approx. 0
30		Ground	ON	—	Approx. 0

# WARNING CHIME

## Terminals and Reference Value for Combination Meter

AKS00D60

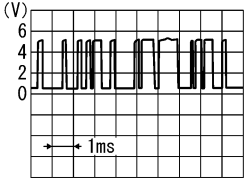
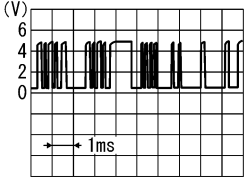
Terminal No.	Wire color	Item	Measuring condition		Reference value (V)
			Ignition switch	Operation or condition	
3	LG	Seat belt buckle switch (Driver side)	ON	Unfastened (ON)	Approx. 0
				Fastened (OFF)	Approx. 12
18	R/L	TX communication line (To unified meter and A/C amp.)	ON	—	
19	R/B	RX communication line (From unified meter and A/C amp.)	ON	—	
20	O	Ignition switch ON or START	ON	—	Battery voltage
21	Y/R	Battery power supply	OFF	—	Battery voltage
22	B	Ground	ON	—	Approx. 0
23					
24					

## Trouble Diagnosis

AKS00D61

### HOW TO PERFORM TROUBLE DIAGNOSIS

1. Confirm the symptom or customer complaint.
2. Understand operation description and function description. Refer to [DI-60, "System Description"](#).
3. Perform the preliminary check. Refer to [DI-69, "PRELIMINARY CHECK"](#).
4. Select "METER A/C AMP" on CONSULT-II, and perform self-diagnosis of unified meter and A/C amp. Refer to [DI-31, "CONSULT-II Function \(METER A/C AMP\)"](#). When no malfunction detected, go to next step 5. When malfunction detected, go to [DI-16, "Symptom Chart 2"](#) in "COMBINATION METER"
5. Check symptom and repair or replace the cause of malfunction.
6. Does the warning chime operate normally? If so, GO TO 7. If not, GO TO 5.
7. INSPECTION END

### PRELIMINARY CHECK

#### Inspection for Power Supply and Ground Circuit

#### 1. CHECK FUSE AND FUSIBLE LINK

Check for blown BCM fuses and fusible link.

Unit	Power source	Fuse and fusible link No.
BCM	Battery	F
		18
	Ignition switch ON or START	1

#### OK or NG

OK >> GO TO 2.

NG >> If fuse is blown, be sure to eliminate cause of malfunction before installing new fuse. Refer to [PG-3, "POWER SUPPLY ROUTING CIRCUIT"](#).

# WARNING CHIME

## 2. CHECK POWER SUPPLY CIRCUIT

Check voltage between BCM harness connector terminals and ground.

Terminals		(-)	Ignition switch position	
(+)			OFF	ON
Connector	Terminal (Wire color)	Ground	OFF	ON
M35	55 (W/B)		Battery voltage	Battery voltage
	42 (GR)		0 V	Battery voltage
M34	38 (R)			

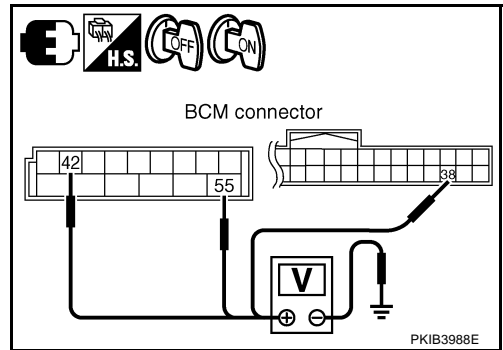

OK or NG

OK >> GO TO 3.

NG >> Check harness for open between BCM and fuse.

## 3. CHECK GROUND CIRCUIT

1. Turn ignition switch OFF.
2. Disconnect BCM connector.
3. Check continuity between BCM harness connector M35 terminal 52 (B) and ground.

**52 (B) – Ground : Continuity should exist.**

OK or NG

OK >> INSPECTION END

NG >> Repair harness or connector.

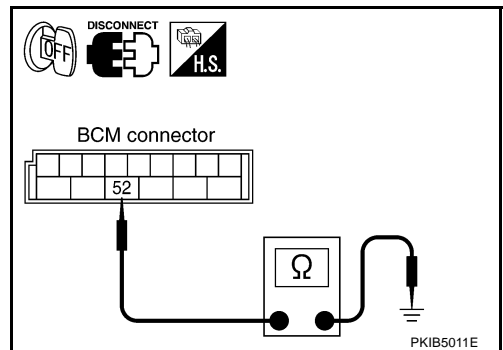

# WARNING CHIME

## CONSULT-II Function (BCM)

AKS00D62

CONSULT-II can display each diagnostic item using the diagnostic test modes shown following.

### DIAGNOSTIC ITEMS DESCRIPTION

System	Test Item	Diagnosis mode	Description	Reference page
BCM	BUZZER	Data monitor	The input data to the BCM control unit is displayed in real time.	<a href="#">DI-72</a>
		Active test	Operation of electrical loads can be checked by sending driving signal to them.	<a href="#">DI-72</a>
	BCM	Self-diagnosis	BCM performs self-diagnosis of CAN communication.	<a href="#">DI-73</a>

### CONSULT-II BASIC OPERATION PROCEDURE

#### CAUTION:

If CONSULT-II is used with no connection of CONSULT-II CONVERTER, malfunctions might be detected in self-diagnosis depending on control unit which carry out CAN communication.

1. With the ignition switch OFF, connect "CONSULT-II" and "CONSULT-II CONVERTER" to the data link connector, and turn the ignition switch ON.

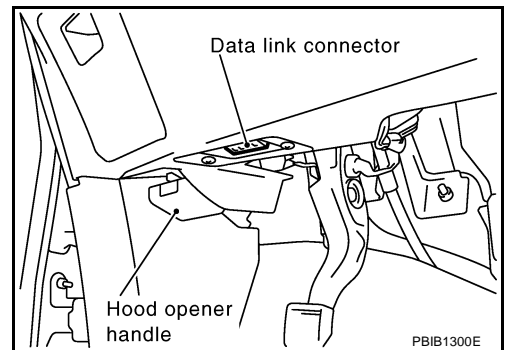

2. Touch "START (NISSAN BASED VHCL)".

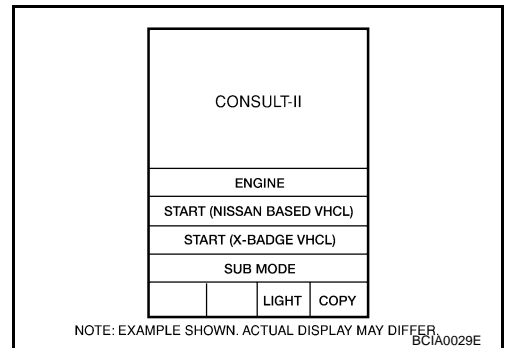

3. Touch "BCM" on "SELECT SYSTEM" screen. If "BCM" is not indicated, go to [GI-39, "CONSULT-II Data Link Connector \(DLC\) Circuit"](#).

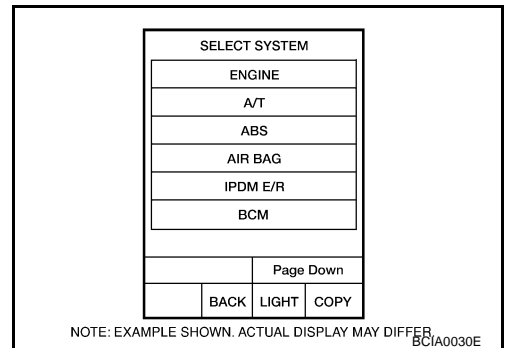

# WARNING CHIME

4. Touch "BUZZER" or "BCM".

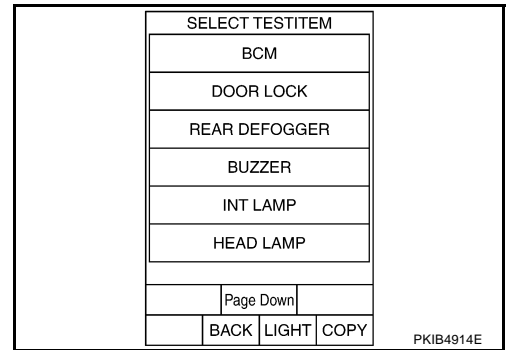

5. Select "DATA MONITOR", "ACTIVE TEST" or "SELF-DIAG RESULTS".

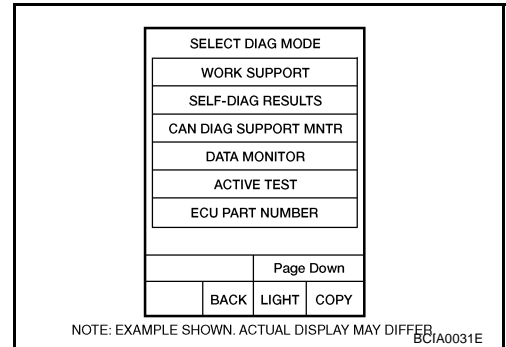

## DATA MONITOR

### Operation Procedure

1. Touch "BUZZER" on "SELECT TEST ITEM" screen.
2. Touch "DATA MONITOR" on "SELECT DIAG MODE" screen.
3. Touch "ALL SIGNALS" or "SELECTION FROM MENU" on "DATA MONITOR" screen.

ALL SIGNALS	Monitors main items.
SELECTION FROM MENU	Selects and monitors items.

4. If "SELECTION FROM MENU" is selected, touch the desired monitor item. If "ALL SIGNALS" is selected, all items required to control are monitored.
5. Touch "START".
6. During monitoring, touching "RECORD" can start recording the monitored item status.

### Display Item List

Monitored item	ALL SIGNALS	SELECTION FROM MENU	Contents
IGN ON SW	X	X	Indicates [ON/OFF] condition of ignition switch.
KEY ON SW	X	X	Indicates [ON/OFF] condition of key switch.
DOOR SW-DR	X	X	Indicates [ON/OFF] condition of front door switch (driver side).
LIGHT SW 1ST	X	X	Indicates [ON/OFF] condition of lighting switch.
BUCKLE SW	X	X	Indicates [ON/OFF] condition of seat belt buckle switch (driver side).

## ACTIVE TEST

### Operation Procedure

1. Touch "BUZZER" on "SELECT TEST ITEM" screen.
2. Touch "ACTIVE TEST" on "SELECT DIAG MODE" screen.
3. Touch the item to be tested, and check the operation.
4. During the operation check, touching "OFF" deactivates the operation.



# WARNING CHIME

## Display Item List

Test item	Malfunction is detected when...
LIGHT WARN ALM	This test is able to check light warning chime operation. Light warning chime sounds for 2 seconds after touching "ON" on CONSULT-II screen.
IGN KEY WARN ALM	This test is able to check key warning chime operation. Key warning chime sounds for 2 seconds after touching "ON" on CONSULT-II screen.
SEAT BELT WARN TEST	This test is able to check seat belt warning chime operation. Seat belt warning chime sounds for 2 seconds after touching "ON" on CONSULT-II screen.

## SELF-DIAGNOSTIC RESULTS

### Operation Procedure

1. Touch "BCM" on "SELECT TEST ITEM" screen.
2. Touch "SELF-DIAG RESULTS" on "SELECT DIAG MODE" screen.
3. Self-diagnosis results are displayed.

### Display Item List

Monitored Item	CONSULT-II display	Description
CAN communication	CAN communication [U1000]	Malfunction is detected in CAN communication.

#### NOTE:

If "CAN communication [U1000]" is indicated, after printing the monitor item, go to "CAN system". Refer to [LAN-5, "Precautions When Using CONSULT-II"](#).

## All Warnings Are Not Operated

AKS00D63

### 1. CHECK CHIME OPERATION

1. Select "BCM" on CONSULT-II.
2. Select "BUZZER" on CONSULT-II, and perform "KEY WARN ALM", "LIGHT WARN ALM" or "SEAT BELT ALM" of "ACTIVE TEST".

#### Does chime sound?

- YES >> Replace BCM. Refer to [BCS-16, "Removal and Installation of BCM"](#).
- NO >> GO TO 2.

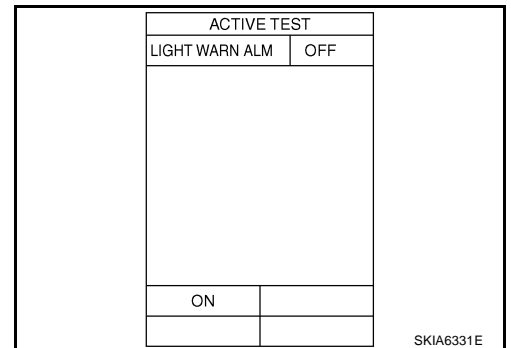

### 2. CHECK UNIFIED METER AND A/C AMP. INPUT SIGNAL

1. Select "METER A/C AMP" on CONSULT-II.
2. Operate switches meet the requirements to sounds warning chime with "BUZZER" of "DATA MONITOR" and check operation status.

#### "BUZZER"

**When meet the requirements to** : ON  
**sounds warning chime**

**Except above** : OFF

#### OK or NG

- OK >> Replace combination meter.
- NG >> Replace BCM. Refer to [BCS-16, "Removal and Installation of BCM"](#).

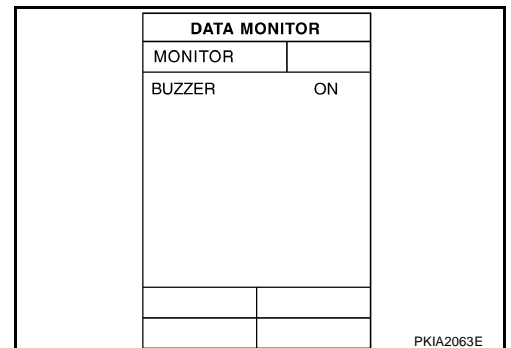

# WARNING CHIME

## Key Warning Chime and Light Warning Chime Does Not Operate (Seat belt Warning Chime Does Operate)

AKS00D64

### 1. CHECK BCM INPUT SIGNAL

#### Ⓟ With CONSULT-II

1. Select "BCM".
2. With "DATA MONITOR" of "BUZZER", confirm "DOOR SW-DR" when the driver side door is operated.

**"DOOR SW-DR"**

**When driver side door is opened : ON**

**When driver side door is closed : OFF**

DATA MONITOR	
MONITOR	
IGN ON SW	ON
KEY ON SW	ON
DOOR SW-DR	OFF

SKIA2003E

#### ⓧ Without CONSULT-II

Check voltage between BCM harness connector M36 terminal 62 (SB) and ground.

**62 (SB) – Ground**

**When driver side door is opened : Approx. 0 V**

**When driver side door is closed : Approx. 12 V**

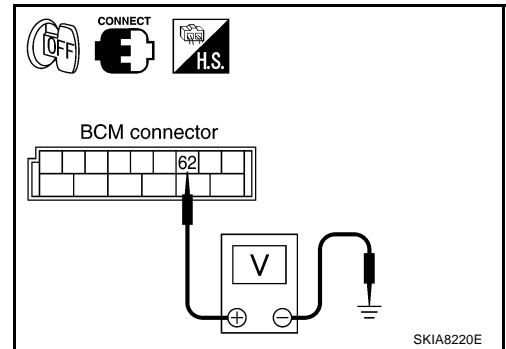

OK or NG

- OK >> Replace BCM. Refer to [BCS-16. "Removal and Installation of BCM"](#).
- NG >> GO TO 2.

### 2. CHECK DRIVER SIDE DOOR SWITCH CIRCUIT

1. Turn ignition switch OFF.
2. Disconnect BCM connector and driver side door switch connector.
3. Check continuity between BCM harness connector M36 terminal 62 (SB) and driver side door switch harness connector D10 terminal 4 (SB).

**62 (SB) – 4 (SB) : Continuity should exist.**

4. Check continuity between BCM harness connector M36 terminal 62 (SB) and ground.

**62 (SB) – Ground : Continuity should not exist.**

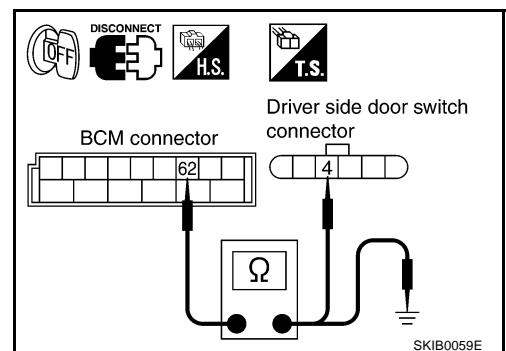

OK or NG

- OK >> GO TO 3.
- NG >> Repair harness or connector.

# WARNING CHIME

## 3. CHECK DRIVER SIDE DOOR SWITCH

Check continuity between driver side door switch connector terminals 4 and 5 while turning the door switch.

4 – 5

**When driver side door is opened : Continuity should exist.**

**When driver side door is closed : Continuity should not exist.**

OK or NG

OK >> GO TO 4.

NG >> Replace driver side door switch.

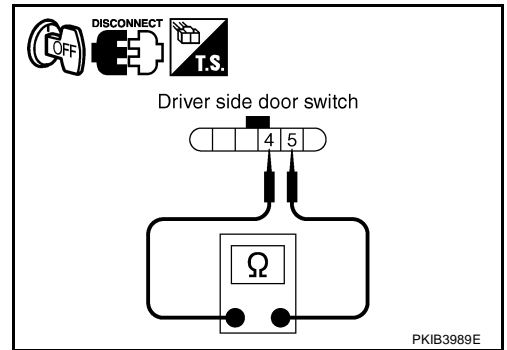

## 4. CHECK DRIVER SIDE DOOR SWITCH GROUND CIRCUIT

Check continuity between driver side door switch harness connector D10 terminal 5 (B) and ground.

**5 (B) – Ground : Continuity should exist.**

OK or NG

OK >> Replace BCM. Refer to [BCS-16, "Removal and Installation of BCM"](#).

NG >> Repair harness.

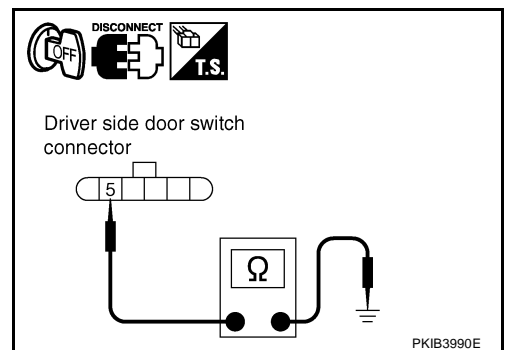

## Key Warning Chime Does Not Operate (Without Intelligent Key)

AKS00D65

### 1. CHECK FUSE

Check if the key switch 10A fuse [No. 21, located in the fuse block (J/B)] is blown. Refer to [DI-64, "Wiring Diagram — CHIME —"](#).

Is the fuse blown?

YES >> Replace fuse. Be sure to repair the cause of malfunction before installing new fuse.

NO >> GO TO 2.

### 2. CHECK WARNING CHIME OPERATION

Check the chime under conditions in exception of key warning chime (without Intelligent Key) operation.

Does warning chime sound?

YES >> GO TO 3.

NO >> Go to [DI-73, "All Warnings Are Not Operated"](#) or [DI-74, "Key Warning Chime and Light Warning Chime Does Not Operate \(Seat belt Warning Chime Does Operate\)"](#).

# WARNING CHIME

## 3. CHECK BCM INPUT SIGNAL

### With CONSULT-II

1. Select "BCM".
2. With "DATA MONITOR" of "BUZZER", confirm "KEY ON SW" when the key is operated.

#### "KEY ON SW"

When key is inserted to ignition key cylinder : ON

When key is removed from ignition key cylinder : OFF

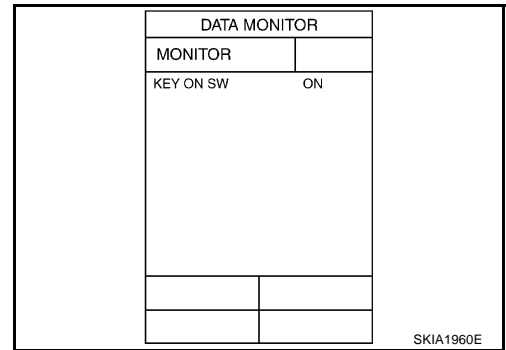

### Without CONSULT-II

Check voltage between BCM harness connector M34 terminal 37 (B/R) and ground.

#### 37 (B/R) – Ground

When key is inserted to ignition key cylinder : Approx. 12 V

When key is removed from ignition key cylinder : Approx. 0 V

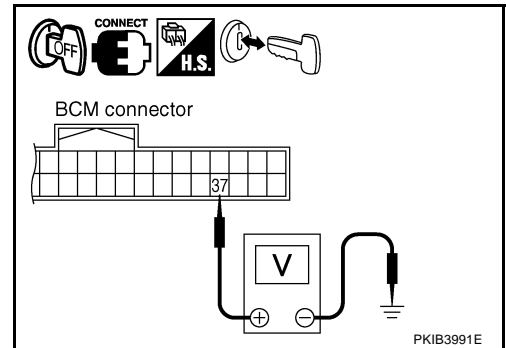

#### OK or NG

OK >> Replace BCM. Refer to [BCS-16, "Removal and Installation of BCM"](#).

NG >> GO TO 4.

## 4. CHECK KEY SWITCH

1. Turn ignition switch OFF.
2. Disconnect key switch connector.
3. Check continuity between key switch connector M28 terminals 3 and 4.

#### 3 – 4

When key is inserted to ignition key cylinder : Continuity should exist.

When key is removed from ignition key cylinder : Continuity should not exist.

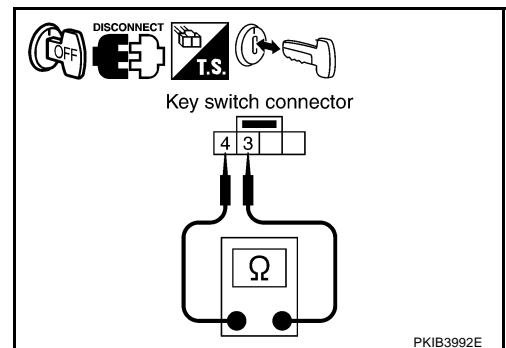

#### OK or NG

OK >> GO TO 5.

NG >> Replace key switch.

# WARNING CHIME

## 5. CHECK KEY SWITCH CIRCUIT

1. Disconnect BCM connector.
2. Check continuity between BCM harness connector M34 terminal 37 (B/R) and key switch harness connector M28 terminal 4 (B/R).

**37 (B/R) – 4 (B/R) : Continuity should exist.**

3. Check continuity between BCM harness connector M34 terminal 37 (B/R) and ground.

**37 (B/R) – Ground : Continuity should not exist.**

OK or NG

OK >> GO TO 6.

NG >> Repair harness or connector.

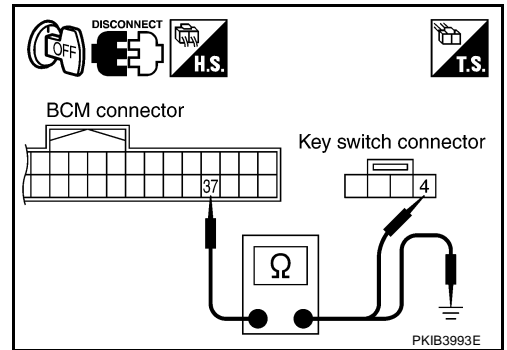

## 6. CHECK KEY SWITCH POWER SUPPLY CIRCUIT

Check voltage between key switch harness connector M28 terminal 3 (Y/R) and ground.

**3 (Y/R) – Ground : Battery voltage**

OK or NG

OK >> Replace BCM. Refer to [BCS-16, "Removal and Installation of BCM"](#).

NG >> Check harness for open between key switch and fuse.

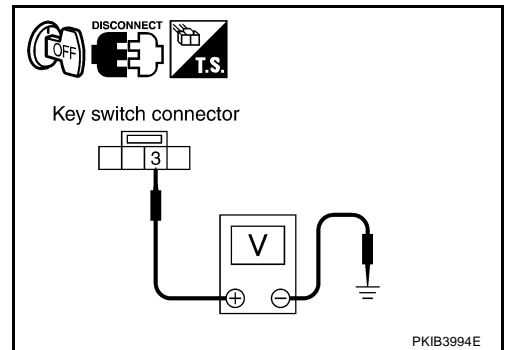

## Key Warning Chime Does Not Operate (With Intelligent Key, When Mechanical Key Is Used)

AKS00D66

### 1. CHECK FUSE

Check if the key switch 10A fuse [No. 22, located in the fuse block (J/B)] is blown. Refer to [DI-64, "Wiring Diagram — CHIME —"](#).

Is the fuse blown?

YES >> Replace fuse. Be sure to repair the cause of malfunction before installing new fuse.

NO >> GO TO 2.

### 2. CHECK WARNING CHIME OPERATION

Check the chime under conditions in exception of key warning chime (when mechanical key is used) operation.

Does warning chime sound?

YES >> GO TO 3.

NO >> Go to [DI-73, "All Warnings Are Not Operated"](#) or [DI-74, "Key Warning Chime and Light Warning Chime Does Not Operate \(Seat belt Warning Chime Does Operate\)"](#).

# WARNING CHIME

## 3. CHECK BCM INPUT SIGNAL

### With CONSULT-II

1. Select "BCM".
2. With "DATA MONITOR" of "BUZZER", confirm "KEY ON SW" when the key is operated.

#### "KEY ON SW"

When key is inserted to ignition key cylinder : ON

When key is removed from ignition key cylinder : OFF

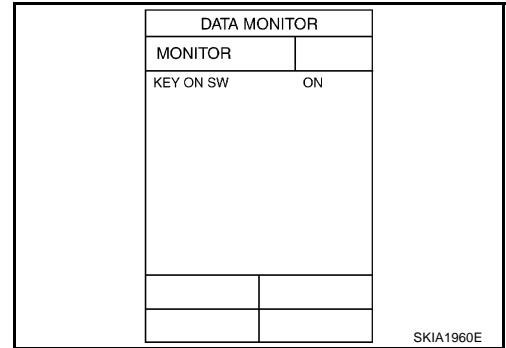

### Without CONSULT-II

- Check voltage between BCM harness connector M34 terminal 37 (B/R) and ground.

#### 37 (B/R) – Ground

When key is inserted to ignition key cylinder : Approx. 12 V

When key is removed from ignition key cylinder : Approx. 0 V

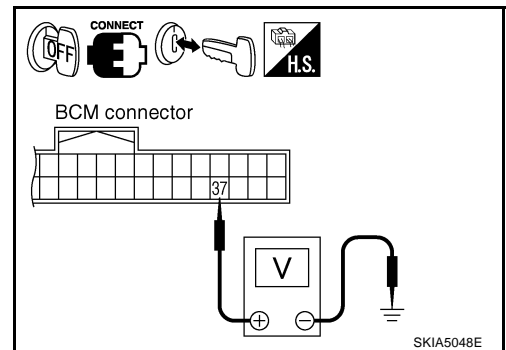

#### OK or NG

OK >> Replace BCM. Refer to [BCS-16, "Removal and Installation of BCM"](#).

NG >> GO TO 4.

## 4. CHECK KEY SWITCH POWER SUPPLY CIRCUIT

1. Turn ignition switch OFF.
2. Disconnect key switch connector.
3. Check voltage between key switch and ignition knob switch harness connector M118 terminal 3 (G/Y) and ground.

3 (G/Y) – Ground : Battery voltage

#### OK or NG

OK >> GO TO 5.

NG >> Check harness between key switch and fuse.

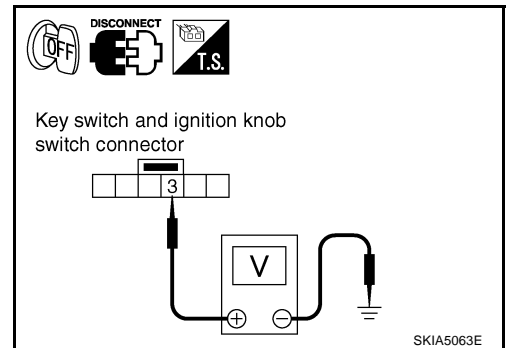

# WARNING CHIME

## 5. CHECK KEY SWITCH

Check continuity between key switch and ignition knob switch connector M118 terminals 3 and 4.

**3 – 4**

**When key is inserted to ignition key cylinder : Continuity should exist.**

**When key is removed from ignition key cylinder : Continuity should not exist.**

OK or NG

OK >> GO TO 6.

NG >> Replace key switch and ignition knob switch.

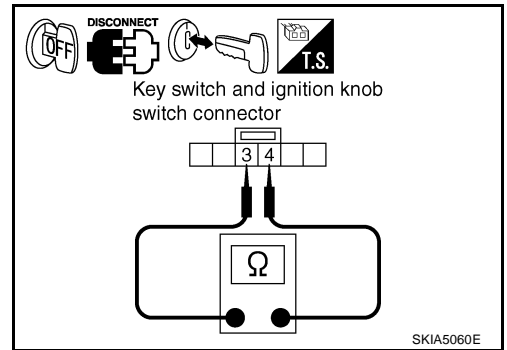

## 6. CHECK KEY SWITCH CIRCUIT

1. Disconnect BCM connector.
2. Check continuity between BCM harness connector M34 terminal 37 (B/R) and key switch and ignition knob switch harness connector M118 terminal 4 (B/R).

**37 (B/R) – 4 (B/R) : Continuity should exist.**

3. Check continuity between BCM harness connector M34 terminal 37 (B/R) and ground.

**37 (B/R) – Ground : Continuity should not exist.**

OK or NG

OK >> Replace BCM. Refer to [BCS-16, "Removal and Installation of BCM"](#).

NG >> Repair harness or connector.

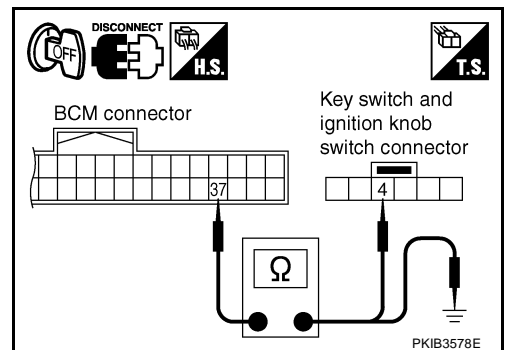

## Key Warning Chime Does Not Operate (With Intelligent Key, When Intelligent Key Is Carried With The Driver)

AKS00D67

Refer to [BL-132, "WARNING CHIME FUNCTION MALFUNCTION"](#).

## Light Warning Chime Does Not Operate

AKS00D68

### 1. CHECK WARNING CHIME OPERATION

Check the chime under conditions in exception of light warning chime operation.

Dose warning chime sound?

YES >> GO TO 2.

NO >> Go to [DI-73, "All Warnings Are Not Operated"](#).

### 2. CHECK BCM INPUT SIGNAL

1. Select "BCM" on CONSULT-II.
2. With "DATA MONITOR" of "BUZZER", confirm "LIGHT SW 1ST" when the lighting switch is operated.

**"LIGHT SW 1ST"**

**When lighting switch is in 1st position : ON**

**When lighting switch is OFF : OFF**

OK or NG

OK >> Replace BCM. Refer to [BCS-16, "Removal and Installation of BCM"](#).

NG >> Replace lighting switch. Refer to [LT-140, "Removal and Installation"](#).

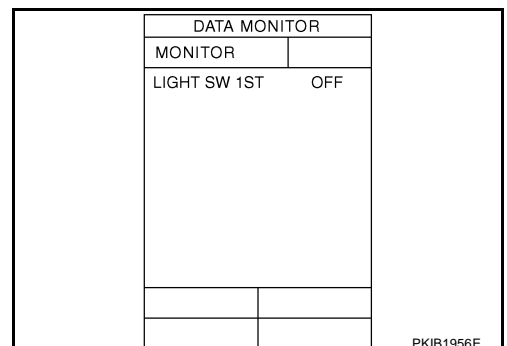

PKIB1956E

# WARNING CHIME

AKS00D69

## Seat Belt Warning Chime Does Not Operate

### 1. CHECK WARNING CHIME OPERATION

Check the chime under conditions in exception of seat belt warning chime operation.

Does warning chime sound?

YES >> GO TO 2.

NO >> Go to [DI-73, "All Warnings Are Not Operated"](#) .

### 2. CHECK BCM INPUT SIGNAL

1. Select "BCM".
2. With "DATA MONITOR" of "BUZZER", confirm "BUCKLE SW" when the seat belt buckle switch is operated.

**"BUCKLE SW"**

**When seat belt is fastened : OFF**

**When seat belt is unfastened : ON**

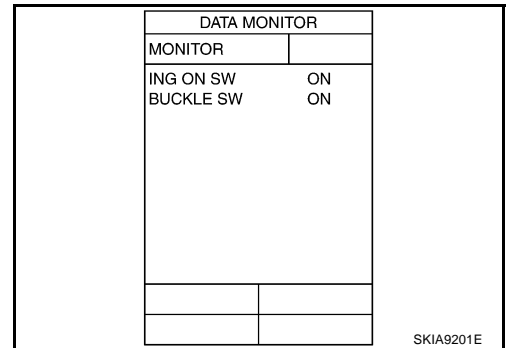

OK or NG

OK >> Replace BCM. Refer to [BCS-16, "Removal and Installation of BCM"](#) .

NG >> GO TO 3.

### 3. CHECK COMBINATION METER INPUT SIGNAL

1. Turn ignition switch ON.
2. Check voltage between combination meter harness connector M25 terminal 3 (LG) and ground.

**3 (LG) – Ground**

**When seat belt is fastened : Approx. 12 V**

**When seat belt is unfastened : Approx. 0 V**

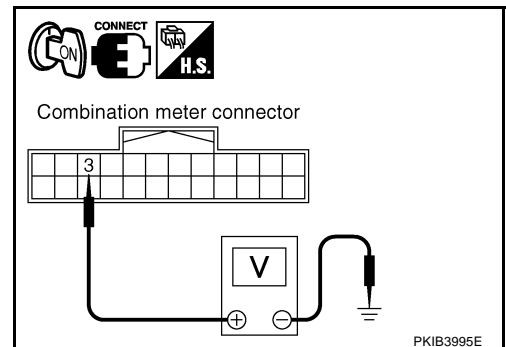

OK or NG

OK >> Replace combination meter.

NG >> GO TO 4.

### 4. CHECK SEAT BELT BUCKLE SWITCH

1. Turn ignition switch OFF.
2. Disconnect seat belt buckle switch (driver side) connector.
3. Check continuity between seat belt buckle switch (driver side) connector B308 terminals 50 and 65.

**50 – 65**

**When seat belt is fastened : Continuity should not exist.**

**When seat belt is unfastened : Continuity should exist.**

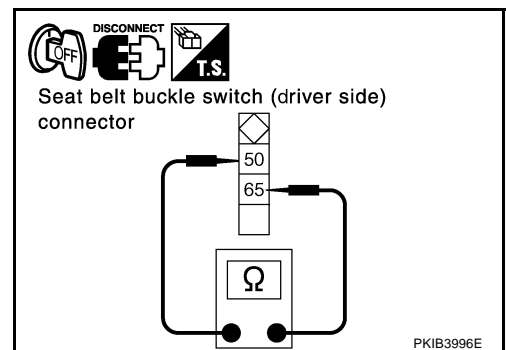

OK or NG

OK >> GO TO 5.

NG >> Replace seat belt buckle switch (driver side).



# WARNING CHIME

## 5. CHECK SEAT BELT BUCKLE SWITCH CIRCUIT

1. Disconnect combination meter connector.
2. Check continuity between combination meter harness connector M25 terminal 3 (LG) and seat belt buckle switch (driver side) harness connector B308 terminal 50 (Y).

**3 (LG) – 50 (Y) : Continuity should exist.**

3. Check harness continuity between combination meter harness connector M25 terminal 3 (LG) and ground.

**3 (LG) – Ground : Continuity should not exist.**

### OK or NG

- OK >> GO TO 6.  
NG >> Repair harness or connector.

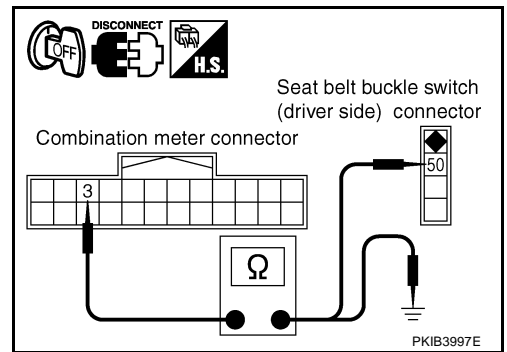

## 6. CHECK SEAT BELT BUCKLE SWITCH GROUND CIRCUIT

Check continuity between seat belt buckle switch (driver side) harness connector B308 terminal 65 (B) and ground.

**65 (B) – Ground : Continuity should exist.**

### OK or NG

- OK >> Replace combination meter.  
NG >> Repair harness or connector.

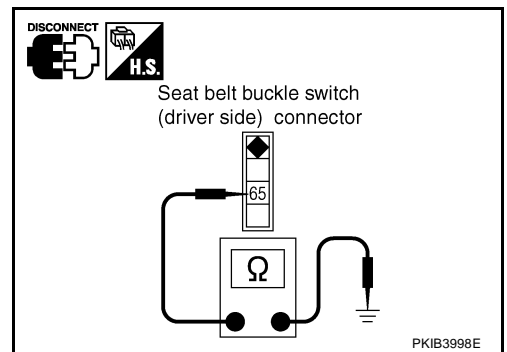

A  
B  
C  
D  
E  
F  
G  
H  
I  
J  
DI  
L  
M

# WARNING CHIME

---