

A  
B  
C  
D  
E

# SECTION **BR** BRAKE SYSTEM

## CONTENTS

<p><b>PRECAUTIONS</b> ..... 3</p> <p style="padding-left: 20px;">Precautions for Supplemental Restraint System (SRS) "AIR BAG" and "SEAT BELT PRE-TENSIONER" ..... 3</p> <p style="padding-left: 20px;">Precautions for Procedures without Cowl Top Cover... 3</p> <p style="padding-left: 20px;">Precautions for Brake System ..... 3</p> <p><b>PREPARATION</b> ..... 4</p> <p style="padding-left: 20px;">Commercial Service Tools ..... 4</p> <p><b>NOISE, VIBRATION AND HARSHNESS (NVH)</b></p> <p><b>TROUBLESHOOTING</b> ..... 5</p> <p style="padding-left: 20px;">NVH Troubleshooting Chart ..... 5</p> <p><b>BRAKE PEDAL</b> ..... 6</p> <p style="padding-left: 20px;">Inspection and Adjustment ..... 6</p> <p style="padding-left: 40px;">PLAY AND CLEARANCE BETWEEN BRAKE PEDAL AND FLOOR PANEL WITH PEDAL DEPRESSED ..... 6</p> <p style="padding-left: 40px;">ADJUSTMENT ..... 7</p> <p style="padding-left: 20px;">Removal and Installation ..... 8</p> <p style="padding-left: 40px;">COMPONENT PARTS LOCATION (NOT FOR ADJUSTABLE PEDAL) ..... 8</p> <p style="padding-left: 40px;">COMPONENT PARTS LOCATION (ADJUSTABLE PEDAL) ..... 9</p> <p style="padding-left: 40px;">REMOVAL ..... 9</p> <p style="padding-left: 40px;">INSPECTION AFTER REMOVAL ..... 10</p> <p style="padding-left: 40px;">INSTALLATION ..... 10</p> <p><b>BRAKE FLUID</b> ..... 11</p> <p style="padding-left: 20px;">On-Board Inspection ..... 11</p> <p style="padding-left: 40px;">LEVEL CHECK ..... 11</p> <p style="padding-left: 20px;">Drain and Refill ..... 11</p> <p style="padding-left: 20px;">Bleeding Brake System ..... 12</p> <p><b>BRAKE PIPING AND HOSE</b> ..... 13</p> <p style="padding-left: 20px;">Hydraulic Circuit ..... 13</p> <p style="padding-left: 20px;">Removal and Installation of Front Brake Piping and Brake Hose ..... 13</p> <p style="padding-left: 40px;">REMOVAL ..... 13</p> <p style="padding-left: 40px;">INSTALLATION ..... 14</p> <p style="padding-left: 20px;">Removal and Installation of Rear Brake Piping and Brake Hose ..... 14</p> <p style="padding-left: 40px;">REMOVAL ..... 14</p>	<p style="padding-left: 20px;">INSTALLATION ..... 14</p> <p style="padding-left: 40px;">Inspection After Installation ..... 14</p> <p><b>BRAKE MASTER CYLINDER</b> ..... 15</p> <p style="padding-left: 20px;">On Board Inspection ..... 15</p> <p style="padding-left: 40px;">LEAK INSPECTION ..... 15</p> <p style="padding-left: 20px;">Removal and Installation ..... 15</p> <p style="padding-left: 40px;">REMOVAL ..... 15</p> <p style="padding-left: 40px;">INSTALLATION ..... 15</p> <p style="padding-left: 20px;">Components ..... 16</p> <p style="padding-left: 40px;">WITH VDC MODELS ..... 16</p> <p style="padding-left: 40px;">WITHOUT VDC MODELS ..... 17</p> <p style="padding-left: 20px;">Disassembly and Assembly ..... 18</p> <p style="padding-left: 40px;">WITHOUT VDC MODELS ..... 18</p> <p style="padding-left: 40px;">WITH VDC MODELS ..... 21</p> <p><b>BRAKE BOOSTER</b> ..... 22</p> <p style="padding-left: 20px;">On-Vehicle Service ..... 22</p> <p style="padding-left: 40px;">OPERATING CHECK ..... 22</p> <p style="padding-left: 40px;">AIRTIGHT CHECK ..... 22</p> <p style="padding-left: 20px;">Removal and Installation ..... 23</p> <p style="padding-left: 40px;">REMOVAL ..... 24</p> <p style="padding-left: 40px;">INSPECTION AFTER REMOVAL ..... 24</p> <p style="padding-left: 40px;">INSTALLATION ..... 24</p> <p><b>VACUUM LINES</b> ..... 25</p> <p style="padding-left: 20px;">Removal and Installation ..... 25</p> <p style="padding-left: 20px;">Inspection ..... 25</p> <p style="padding-left: 40px;">VISUAL INSPECTION ..... 25</p> <p style="padding-left: 40px;">CHECK VALVE INSPECTION ..... 26</p> <p><b>FRONT DISC BRAKE</b> ..... 27</p> <p style="padding-left: 20px;">On-Board Inspection ..... 27</p> <p style="padding-left: 40px;">PAD WEAR INSPECTION ..... 27</p> <p style="padding-left: 20px;">Components ..... 27</p> <p style="padding-left: 20px;">Removal and Installation of Brake Pad ..... 28</p> <p style="padding-left: 40px;">REMOVAL ..... 28</p> <p style="padding-left: 40px;">INSTALLATION ..... 28</p> <p style="padding-left: 20px;">Removal and Installation of Brake Caliper Assembly</p> <p style="padding-left: 40px;">... 28</p> <p style="padding-left: 40px;">REMOVAL ..... 28</p> <p style="padding-left: 40px;">INSTALLATION ..... 29</p> <p style="padding-left: 20px;">Disassembly and Assembly of Brake Caliper</p>
--	--

BR

G

H

I

J

K

L

M

Assembly .....	29	INSTALLATION .....	34
DISASSEMBLY .....	29	Disassembly and Assembly of Brake Caliper	
CALIPER INSPECTION .....	30	Assembly .....	35
ASSEMBLY .....	30	DISASSEMBLY .....	35
DISC ROTOR INSPECTION .....	31	CALIPER INSPECTION .....	36
BRAKE BURNISHING PROCEDURE .....	32	ASSEMBLY .....	36
<b>REAR DISC BRAKE .....</b>	<b>33</b>	DISC ROTOR INSPECTION .....	38
On-Board Inspection .....	33	BRAKE BURNISHING PROCEDURE .....	38
PAD WEAR INSPECTION .....	33	<b>SERVICE DATA AND SPECIFICATIONS (SDS) .....</b>	<b>39</b>
Components .....	33	General Specifications .....	39
Removal and Installation of Brake Pad .....	34	Brake Pedal .....	39
REMOVAL .....	34	Brake Booster .....	39
INSTALLATION .....	34	Check Valve .....	39
Removal and Installation of Brake Caliper Assembly		Front Disc Brake .....	39
... ..	34	Rear Disc Brake .....	39
REMOVAL .....	34		

# PRECAUTIONS

## PRECAUTIONS

PFP:00001

### Precautions for Supplemental Restraint System (SRS) “AIR BAG” and “SEAT BELT PRE-TENSIONER”

AFS00290

The Supplemental Restraint System such as “AIR BAG” and “SEAT BELT PRE-TENSIONER”, used along with a front seat belt, helps to reduce the risk or severity of injury to the driver and front passenger for certain types of collision. This system includes seat belt switch inputs and dual stage front air bag modules. The SRS system uses the seat belt switches to determine the front air bag deployment, and may only deploy one front air bag, depending on the severity of a collision and whether the front occupants are belted or unbelted. Information necessary to service the system safely is included in the SRS and SB section of this Service Manual.

#### **WARNING:**

- To avoid rendering the SRS inoperative, which could increase the risk of personal injury or death in the event of a collision which would result in air bag inflation, all maintenance must be performed by an authorized NISSAN/INFINITI dealer.
- Improper maintenance, including incorrect removal and installation of the SRS, can lead to personal injury caused by unintentional activation of the system. For removal of Spiral Cable and Air Bag Module, see the SRS section.
- Do not use electrical test equipment on any circuit related to the SRS unless instructed to in this Service Manual. SRS wiring harnesses can be identified by yellow and/or orange harnesses or harness connectors.

### Precautions for Procedures without Cowl Top Cover

AFS0038M

When performing the procedure after removing cowl top cover, cover the lower end of windshield with urethane, etc.

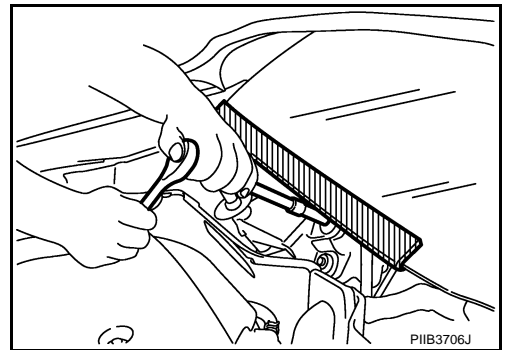

### Precautions for Brake System

AFS0016P

- Recommended fluid is brake fluid “DOT 3”.
- Do not reuse drained brake fluid.
- Be careful not to splash brake fluid on painted areas; it may cause paint damage. If brake fluid is splashed on painted areas, wash it away with water immediately.
- To clean or wash all parts of master cylinder, disc brake caliper and wheel cylinder, use clean brake fluid.
- Never use mineral oils such as gasoline or kerosene. They will ruin rubber parts of the hydraulic system.
- Use flare nut wrench when removing and installing brake tube.
- When installing brake piping, be sure to torque.
- Before working, turn ignition switch OFF and disconnect connectors of ABS actuator and control unit or battery negative terminal.
- Burnish the brake contact surfaces after refinishing or replacing drums or rotors, after replacing pads or linings, or if a soft pedal occurs at very low mileage.  
Refer to [BR-32, "BRAKE BURNISHING PROCEDURE"](#).

#### **WARNING:**

- Clean brake pads and shoes with a waste cloth, then wipe with a dust collector.

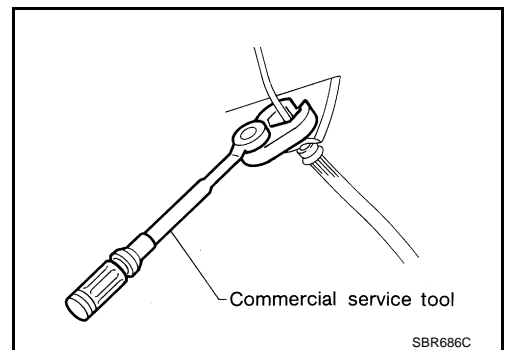

# PREPARATION

## PREPARATION

PFP:00002

### Commercial Service Tools

AFS0016Q

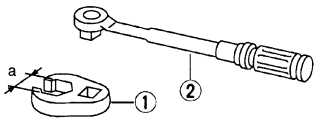
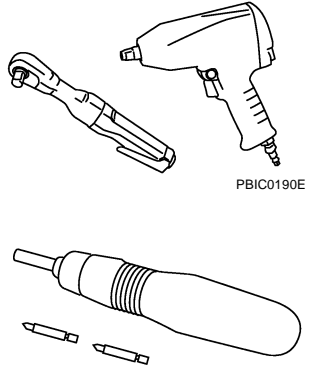
Tool name	Description
<p>1. Flare nut crowfoot a: 10 mm (0.39 in) / 12 mm (0.47 in)</p> <p>2. Torque wrench</p>  <p>S-NT360</p>	<p>Removing and installing each brake piping</p>
<p>Power tool</p>  <p>PBIC0190E</p> <p>PBIC0191E</p>	<p>Removing front and rear caliper assembly, tires</p>

# NOISE, VIBRATION AND HARSHNESS (NVH) TROUBLESHOOTING

## NOISE, VIBRATION AND HARSHNESS (NVH) TROUBLESHOOTING

PPF:00003

### NVH Troubleshooting Chart

AFS0016R

Use the chart below to help you find the cause of the symptom. If necessary, repair or replace these parts.

Symptom	Brake	Possible cause and suspected parts														Reference page									
		Pads - damaged	Pads - uneven wear	Shims damaged	Rotor imbalance	Rotor damage	Rotor runout	Rotor deformation	Rotor deflection	Rotor rust	Rotor thickness variation	Drum out of round	PROPELLER SHAFT	DIFFERENTIAL	AXLE AND SUSPENSION		TIRES	ROAD WHEEL	DRIVE SHAFT	STEERING					
Noise		x	x	x																					BR-27, BR-33
Shake					x																				BR-28, BR-34
Shimmy, Judder					x	x	x	x	x	x															BR-27, BR-33
																									—
																									—
																									BR-31, BR-38
																									—
																									NVH in PR section
																									NVH in RFD section
																									NVH in FAX, RAX and FSU, RSU section
																									NVH in WT section
																									NVH in WT section
																									NVH in FAX and RAX section
																									NVH in PS section

x: Applicable

A  
B  
C  
D  
E  
BR  
G  
H  
I  
J  
K  
L  
M

# BRAKE PEDAL

## BRAKE PEDAL

PFPA:46501

### Inspection and Adjustment

AFS0016S

#### PLAY AND CLEARANCE BETWEEN BRAKE PEDAL AND FLOOR PANEL WITH PEDAL DEPRESSED

1. Check the brake pedal free height from dash floor panel.
2. Adjust the height referring to the following specifications.

**CAUTION:**

When adjustable pedal is equipped during the pedal height measurement, pedal must be in the front most position.

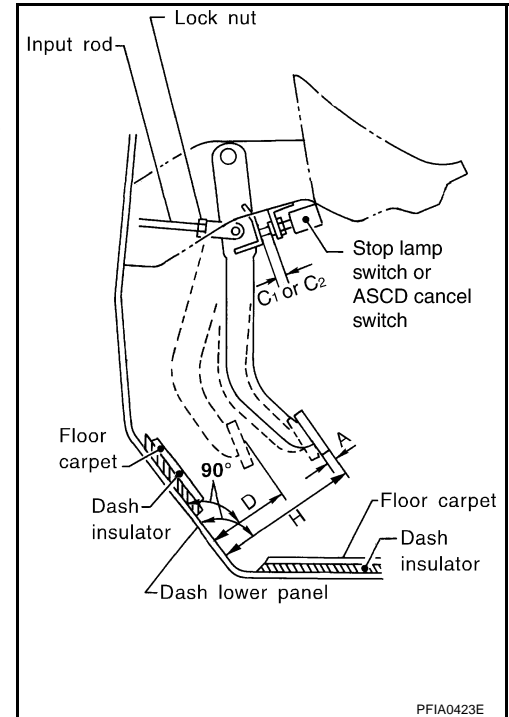

H	Brake pedal height (from dash panel top surface)	199.5 - 209.5 mm (7.85 - 8.25 in)
D	Depressed pedal height [under a force of 490 N (50 kg, 110 lb) with engine running]	More than 120 mm (4.72 in)
C1 or C2	Clearance between bracket and threaded end of ASCD cancel switch or stop lamp switch	0.74 - 1.96 mm (0.0291 - 0.0772 in)
A	Pedal play	3 - 11 mm (0.12 - 0.43 in)

# BRAKE PEDAL

## ADJUSTMENT

1. Loosen the stop lamp switch and ASCD cancel switch by turning it counterclockwise by 45°.
2. Loosen lock nut (A) on the input rod, then turn input rod to adjust the pedal to specified height, and tighten lock nut (A).

**CAUTION:**

**Make sure the threaded end of the input rod stays inside the clevis.**

**Lock nut (A)** :

**15.7 - 21.6 N·m (1.6 - 2.2 kg·m, 12 - 15 in·lb)**

3. With the pedal pulled and held by hand, press the stop lamp switch and ASCD cancel switch until its threaded end contacts the bracket.
4. With the threaded end of the stop lamp switch and ASCD cancel switch contacting the bracket, turn the switch clockwise by 45° to secure.

**CAUTION:**

**Make sure that the clearance (C) between the bracket and threaded end of the stop lamp switch is within the standard.**

5. Check the pedal play.

**CAUTION:**

**Make sure that the stop lamp goes off when the pedal is released.**

6. Start the engine to check the brake pedal depressed height.

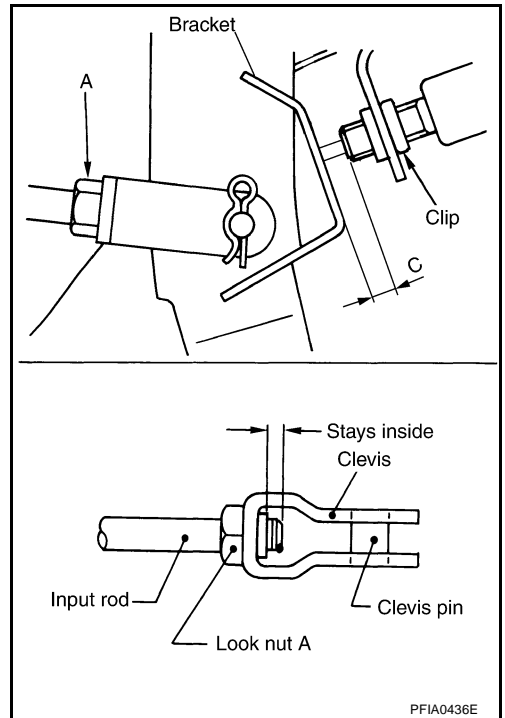

A  
B  
C  
D  
E  
BR  
G  
H  
I  
J  
K  
L  
M

# BRAKE PEDAL

AFS0016T

## Removal and Installation

### COMPONENT PARTS LOCATION (NOT FOR ADJUSTABLE PEDAL)

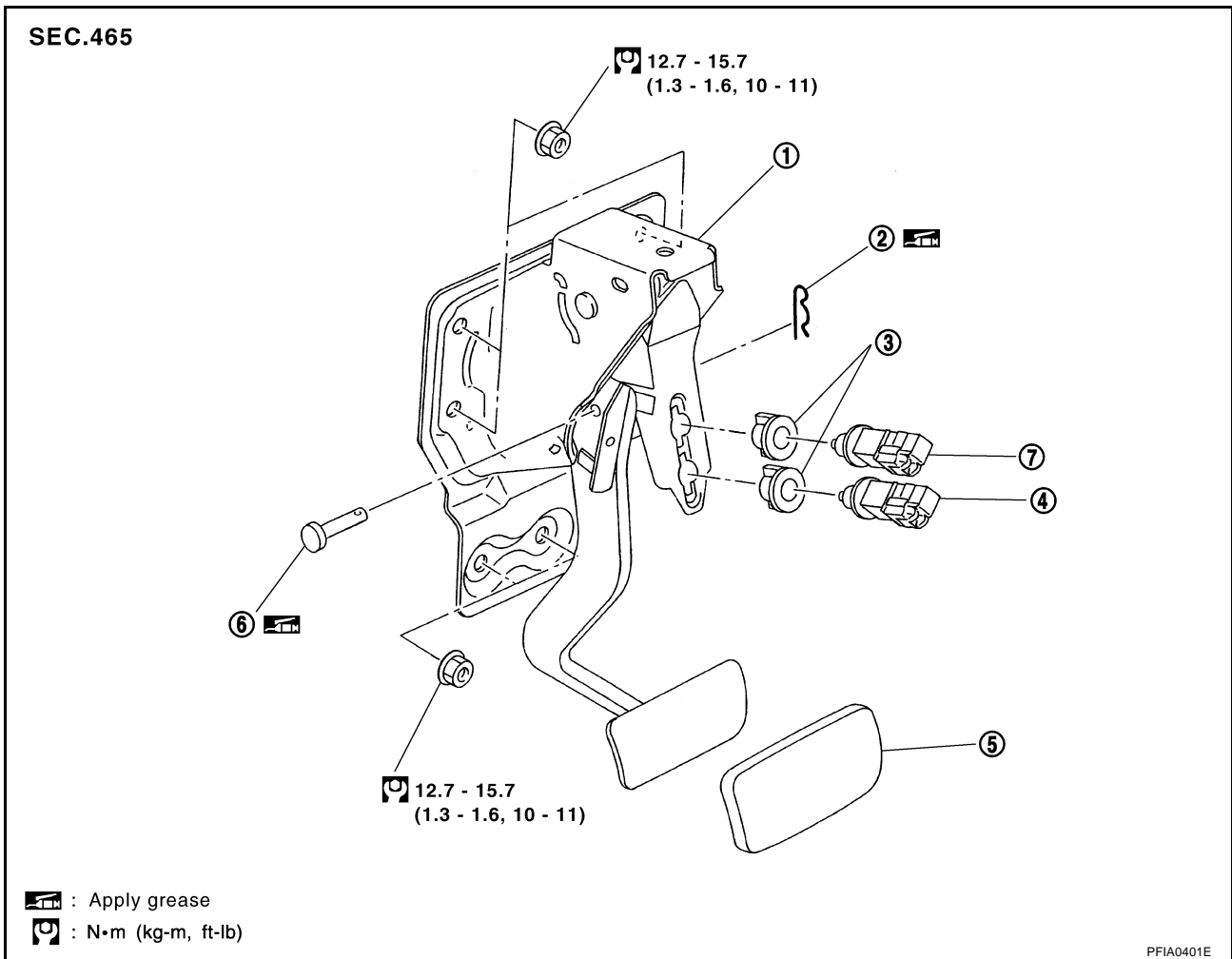

- 1. Brake pedal assembly
- 4. Stop lamp switch
- 7. ASCD cancel switch

- 2. Snap pin
- 5. Pedal pad

- 3. Clip
- 6. Clevis pin



# BRAKE PEDAL

## COMPONENT PARTS LOCATION (ADJUSTABLE PEDAL)

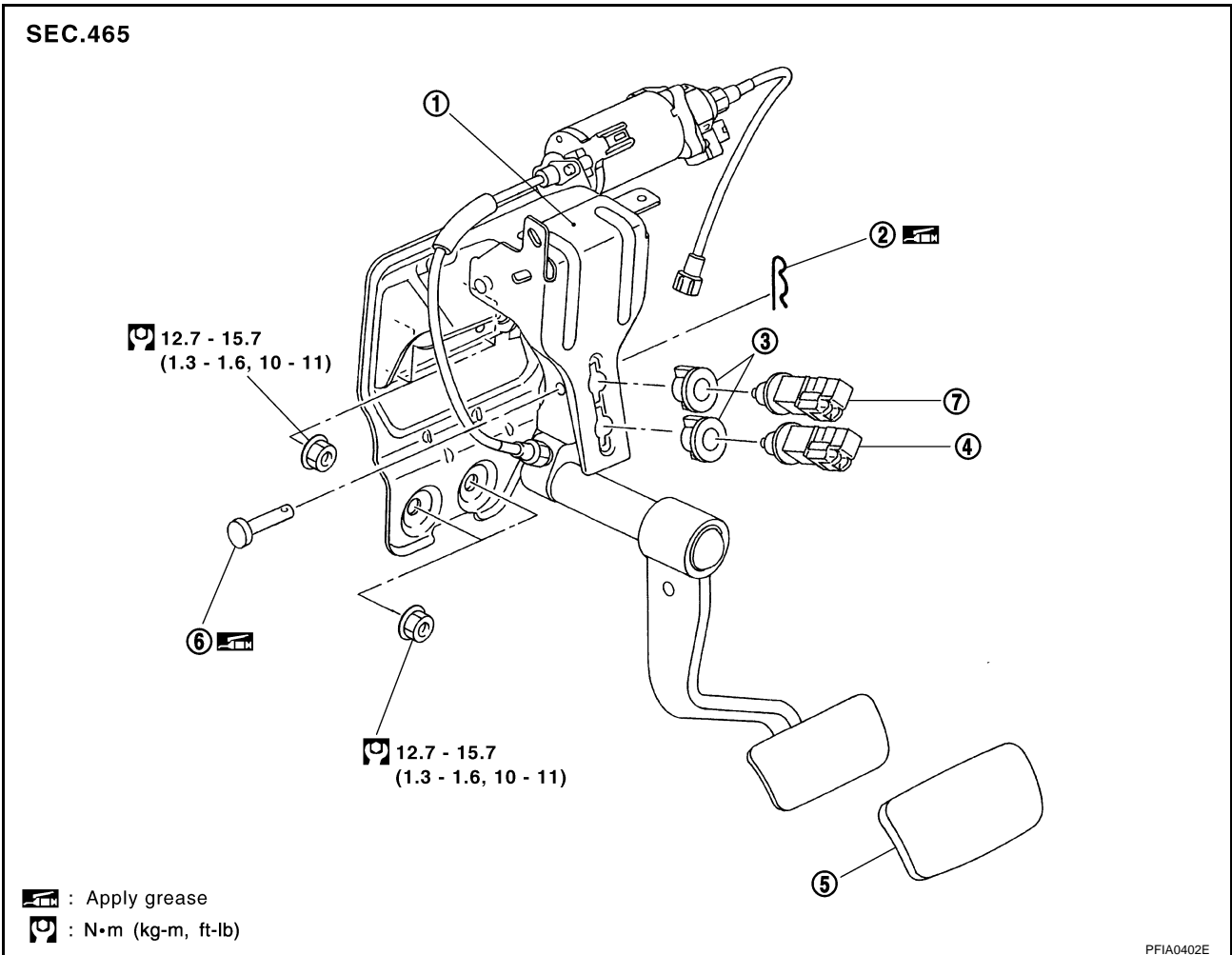

- |                         |              |               |
|-------------------------|--------------|---------------|
| 1. Brake pedal assembly | 2. Snap pin  | 3. Clip       |
| 4. Stop lamp switch     | 5. Pedal pad | 6. Clevis pin |
| 7. ASCD cancel switch   |              |               |

## REMOVAL

### CAUTION:

- Adjust mechanism (Drive wire, Drive motor) is not able to disassemble.
- Before removing pedal drive cable, pedals must be in the front position to keep the proper position between accelerator and brake pedal.

1. Remove front kick plate (driver side). Refer to [EI-32, "BODY SIDE TRIM"](#) .
2. Remove front body side welt (driver side). Refer to [EI-32, "BODY SIDE TRIM"](#) .
3. Remove instrument driver lower panel. Refer to [IP-10, "INSTRUMENT PANEL ASSEMBLY"](#) .
4. Remove dash side finisher (driver side). Refer to [EI-32, "BODY SIDE TRIM"](#) .
5. Remove parking brake pedal assembly. Refer to [PB-3, "Removal and Installation"](#) .
6. Disconnect accelerator pedal drive cable, drive motor harness connector. (With adjustable pedal)
7. Remove stop lamp switch and ASCD cancel switch from the pedal assembly.

# BRAKE PEDAL

8. Remove snap pin and clevis pin from input rod clevis.
9. Remove mounting nuts from pedal bracket, and remove pedal assembly from vehicle.

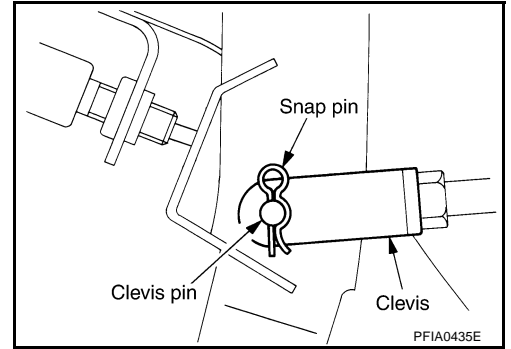

## INSPECTION AFTER REMOVAL

- Check the clevis pin and resin stopper for damage and deformation. If a malfunction is detected, replace the clevis pin and resin stopper.

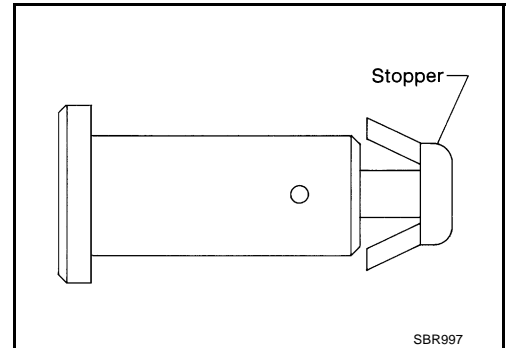

## INSTALLATION

Note the following, and install in the reverse order of removal.

- After installing the brake pedal assembly to the vehicle, adjust the brake pedal. Refer to [BR-6, "Inspection and Adjustment"](#) .

# BRAKE FLUID

## BRAKE FLUID

PFP:KN100

### On-Board Inspection LEVEL CHECK

AFS0016U

- Make sure the fluid level in the sub-tank is within the standard (between MAX and MIN lines).
- Visually check around the reservoir tank and sub-tank for fluid leakage.
- If fluid level is excessively low, check brake system for fluid leakage.
- If brake warning lamp remains illuminated after parking brake pedal is released, check brake system for fluid leaks.

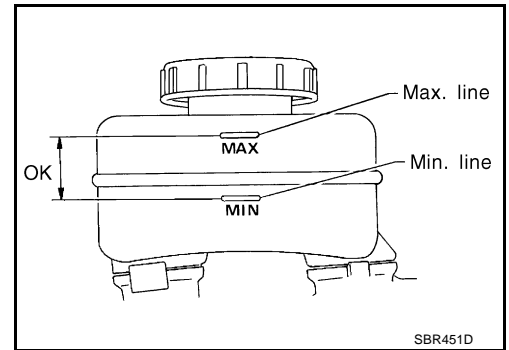

### Drain and Refill

AFS0016V

#### CAUTION:

- Refill with new brake fluid "DOT3".
- Never reuse drained brake fluid.
- Be careful not to splash brake fluid on painted areas; it may cause paint damage. If brake fluid is splashed on painted areas wash it away with water immediately.

1. Connect a vinyl tube to air bleeder valve.
2. Depress the brake pedal, loosen the air bleeder valve, and gradually remove the brake fluid.
3. Turn ignition switch OFF and disconnect ABS actuator and electric unit (control unit) connector or battery negative cable.

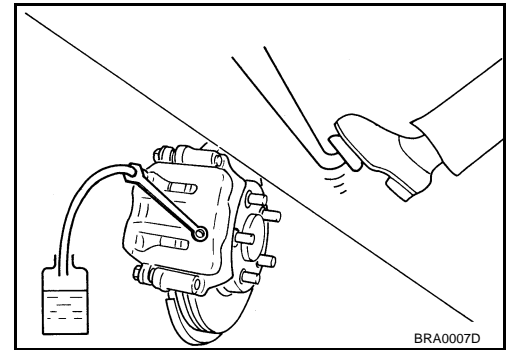

4. Make sure there is no foreign material in the sub tank, and refill with new brake fluid.
5. Rest foot on brake pedal. Loosen air bleeder valve. Slowly depress pedal until it stops. Tighten air bleeder valve. Release brake pedal. Repeat this process a few times, then pause to add new brake fluid to master cylinder. Continue until new brake fluid flows out.
6. Bleed Air. Refer to [BR-12. "Bleeding Brake System"](#) .

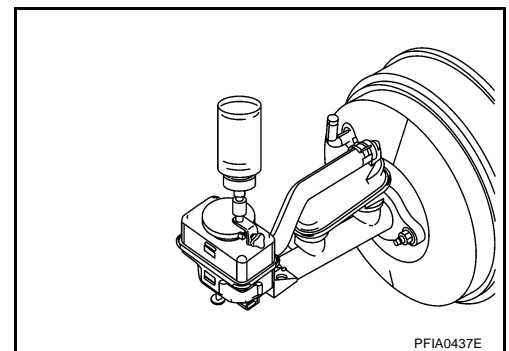

# BRAKE FLUID

---

## Bleeding Brake System

AFS0016W

### **CAUTION:**

**While bleeding, pay attention to master cylinder fluid level.**

1. Turn ignition switch OFF and disconnect ABS actuator and electric unit (control unit) connector or battery negative cable.
2. Connect a vinyl tube to the rear right air bleeder valve.
3. Fully depress brake pedal 4 to 5 times.
4. With brake pedal depressed, loosen air bleeder valve to let the air out, and then tighten it immediately.
5. Repeat steps 3, 4 until no more air comes out.
6. Tighten air bleeder valve to specified torque.
7. In steps 2 to 6 below, with master cylinder sub tank filled at least half way, bleed air from the front left, rear left, and front right tires, in that order.

### Hydraulic Circuit

AFS0016X

SEC.462

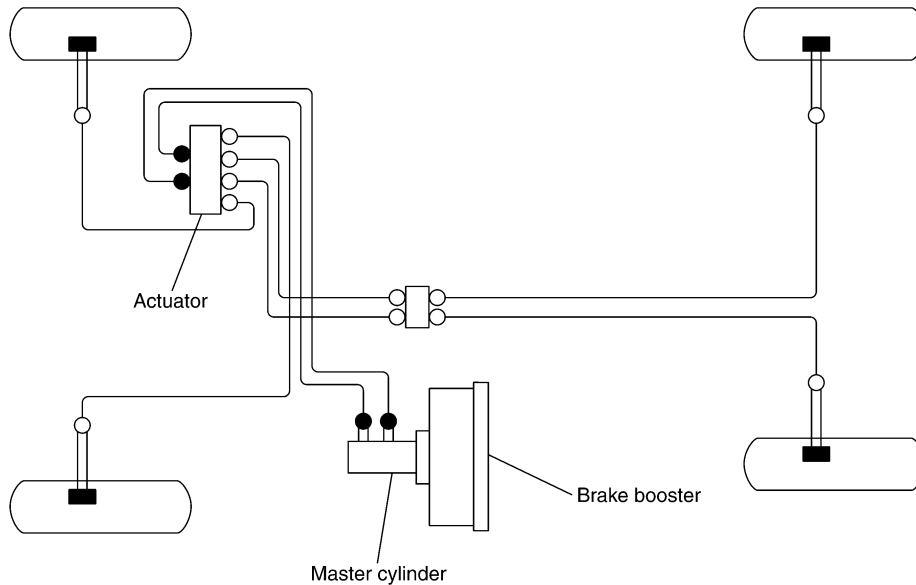

- : Without VDC model 14.8-17.6N·m (1.5-1.7kg-m,11-12ft-lb), VDC model 16.7-19.6N·m (1.7-1.9kg-m,13-14ft-lb)
- : Union bolt 16.7-19.6N·m (1.7-1.9kg-m,13-14ft-lb)
- : Flare nut 14.8-17.6N·m (1.5-1.7kg-m,11-12ft-lb)

PFIA0403E

### CAUTION:

- All hoses and pipings (tubes) must be free from excessive bending, twisting and pulling.
- Make sure there is no interference with other parts when turning steering both clockwise and counterclockwise.
- The brake piping is an important safety part. If a brake fluid leak is detected, always disassemble the parts. Replace applicable part with a new one, if necessary.
- Be careful not to splash brake fluid on painted areas; it may cause paint damage. If brake fluid is splashed on painted areas, wash it away with water immediately.
- Do not bend or twist brake hose sharply, or strongly pull it.
- When removing components, put cover on the connections so that no dirt, no dust, or no other foreign matter gets in.
- Refill with new brake fluid " DOT 3 "
- Do not reuse drained brake fluid.

## Removal and Installation of Front Brake Piping and Brake Hose

AFS0016Y

### REMOVAL

1. Drain brake fluid. Refer to [BR-11, "Drain and Refill"](#) .
2. Using a flare nut wrench, remove brake tube from brake hose.
3. Remove union bolt and remove the brake hose from the caliper assembly.
4. Remove the lock plate and remove the brake hose from the vehicle.

# BRAKE PIPING AND HOSE

## INSTALLATION

1. Install brake hose by aligning with the protrusion on caliper assembly, and tighten union bolt to the specified torque.

 : 16.7 - 19.6 N·m (1.7 - 1.9 kg·m, 13 - 14 ft·lb)

### NOTE:

Do not reuse the copper washer.

2. Install brake hose to the brake tube, partially tighten the flare nut as much as possible by hand, then secure it to the bracket with lock plate.
3. Using a flare nut torque wrench, tighten flare nut to the specified torque.

 : 14.8 - 17.6 N·m (1.5 - 1.7 kg·m, 11 - 12 ft·lb)

4. Refill brake fluid and bleed air. Refer to [BR-11, "Drain and Refill"](#) .

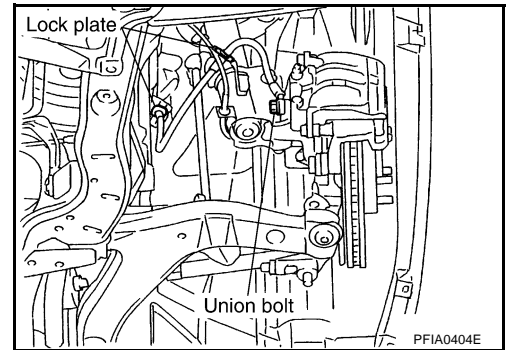

## Removal and Installation of Rear Brake Piping and Brake Hose

AFS00170

### REMOVAL

1. Drain brake fluid. Refer to [BR-11, "Drain and Refill"](#) .
2. Using a flare nut wrench, remove brake tube from brake hose.
3. Remove union bolts, and then remove brake hose from the caliper assembly.
4. Remove the lock plate and then remove the brake hose from the vehicle.

### INSTALLATION

1. Install the brake hose to the caliper assembly positioning hole and tighten union bolt to the specified torque.

 : 16.7 - 19.6 N·m (1.7 - 1.9 kg·m, 13 - 14 ft·lb)

### NOTE:

Do not reuse the copper washer.

2. Install brake hose to the brake tube, partially tighten the flare nut as much as possible by hand, then secure it to the bracket with lock plate.
3. Using a flare nut torque wrench, tighten flare nut to the specified torque.
4. Refill brake fluid and bleed air. Refer to [BR-12, "Bleeding Brake System"](#) .

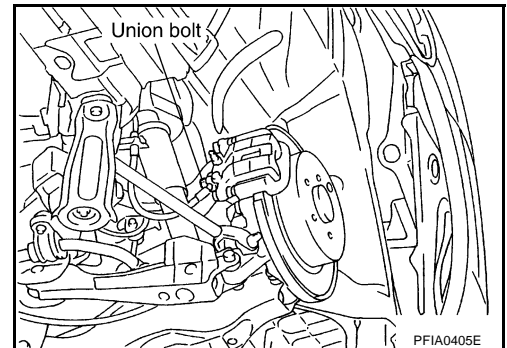

## Inspection After Installation

AFS00172

### CAUTION:

**If leakage occurs around hose and tube connections, retighten. If necessary, replace damaged part.**

1. Check brake lines (tubes and hoses) and connections for fluid leakage, damage, twist, deformation, contact with other parts, and loose connections. Replace any damage parts.
2. While depressing brake pedal under a force of 785 N (80 kg, 177 lb) with engine running at idle speed for approximately 5 seconds, check each part for fluid leakage.

# BRAKE MASTER CYLINDER

## BRAKE MASTER CYLINDER

PPF:46010

### On Board Inspection LEAK INSPECTION

AFS00173

- Check for fluid leakage from master cylinder attachment portion, reservoir tank, reservoir hose connections, and brake tube connections.

### Removal and Installation

AFS00174

#### **CAUTION:**

Be careful not to splash brake fluid on painted areas; it may cause paint damage. If brake fluid is splashed on painted areas wash it away with water immediately.

#### REMOVAL

1. Drain brake fluid. Refer to [BR-11, "Drain and Refill"](#) .
2. Remove air cleaner and air duct. Refer to [EM-16, "AIR CLEANER AND AIR DUCT"](#) .
3. Disconnect harness connectors for fluid level sensor and pressure sensor (VDC model only).
4. Using a flare nut wrench, disconnect master cylinder assembly and brake tube.
5. Remove master cylinder assembly nut, remove sub-tank assembly bolt and remove master cylinder assembly from vehicle. Refer to [BR-23, "Removal and Installation"](#) .

#### INSTALLATION

#### **CAUTION:**

- Refill with new brake fluid "DOT3".
- Do not reuse drained brake fluid.
- Install in the reverse order of removal.
- Refill brake fluid and bleed air. Refer to [BR-12, "Bleeding Brake System"](#) .

# BRAKE MASTER CYLINDER

## Components WITH VDC MODELS

AFS00175

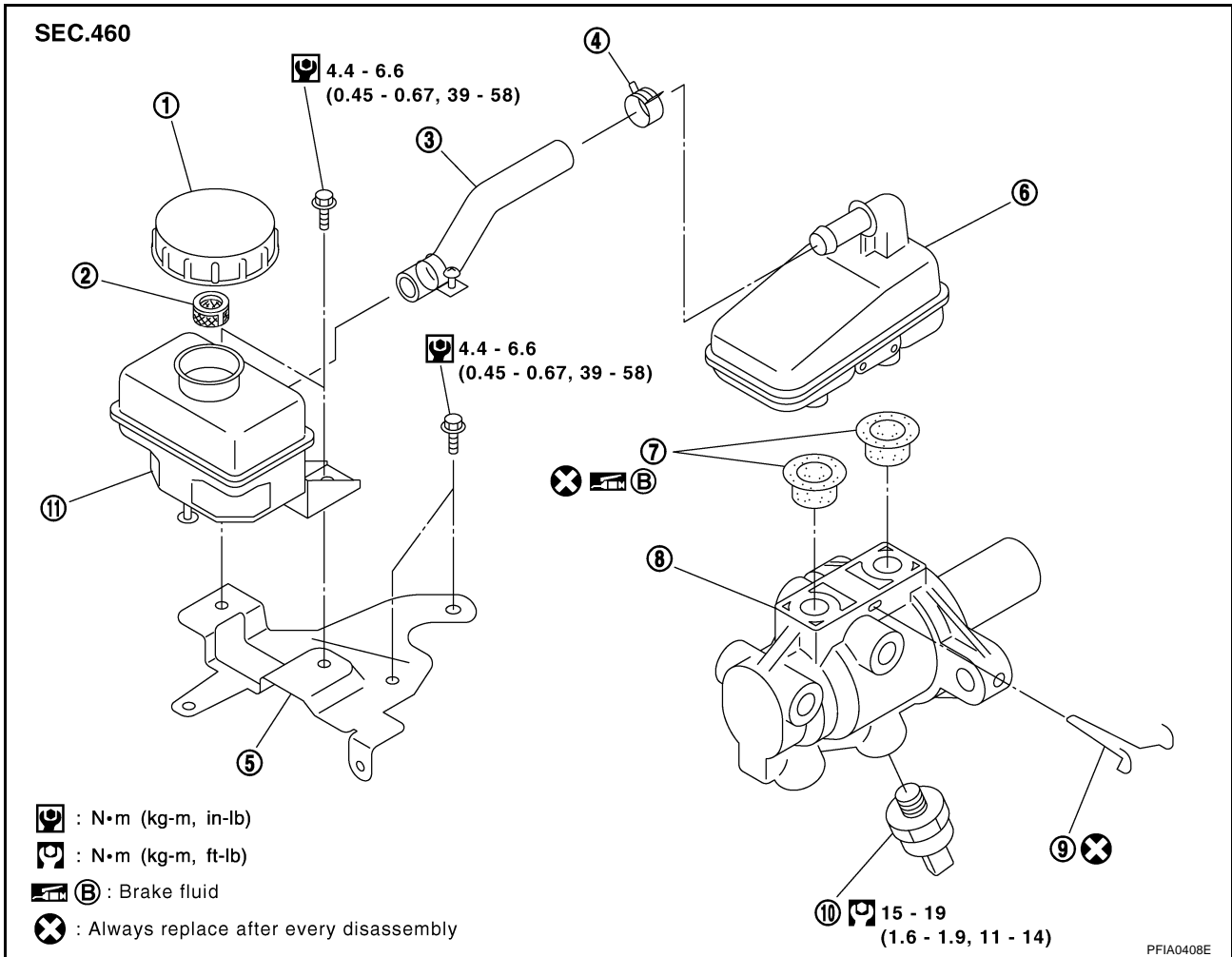

PFIA0408E

- |                     |                             |                   |
|---------------------|-----------------------------|-------------------|
| 1. Reservoir cap    | 2. Oil strainer             | 3. Hose and clamp |
| 4. Clamp            | 5. Bracket                  | 6. Reservoir tank |
| 7. Grommet          | 8. Master cylinder assembly | 9. Clip           |
| 10. Pressure sensor | 11. Sub tank                |                   |



# BRAKE MASTER CYLINDER

## WITHOUT VDC MODELS

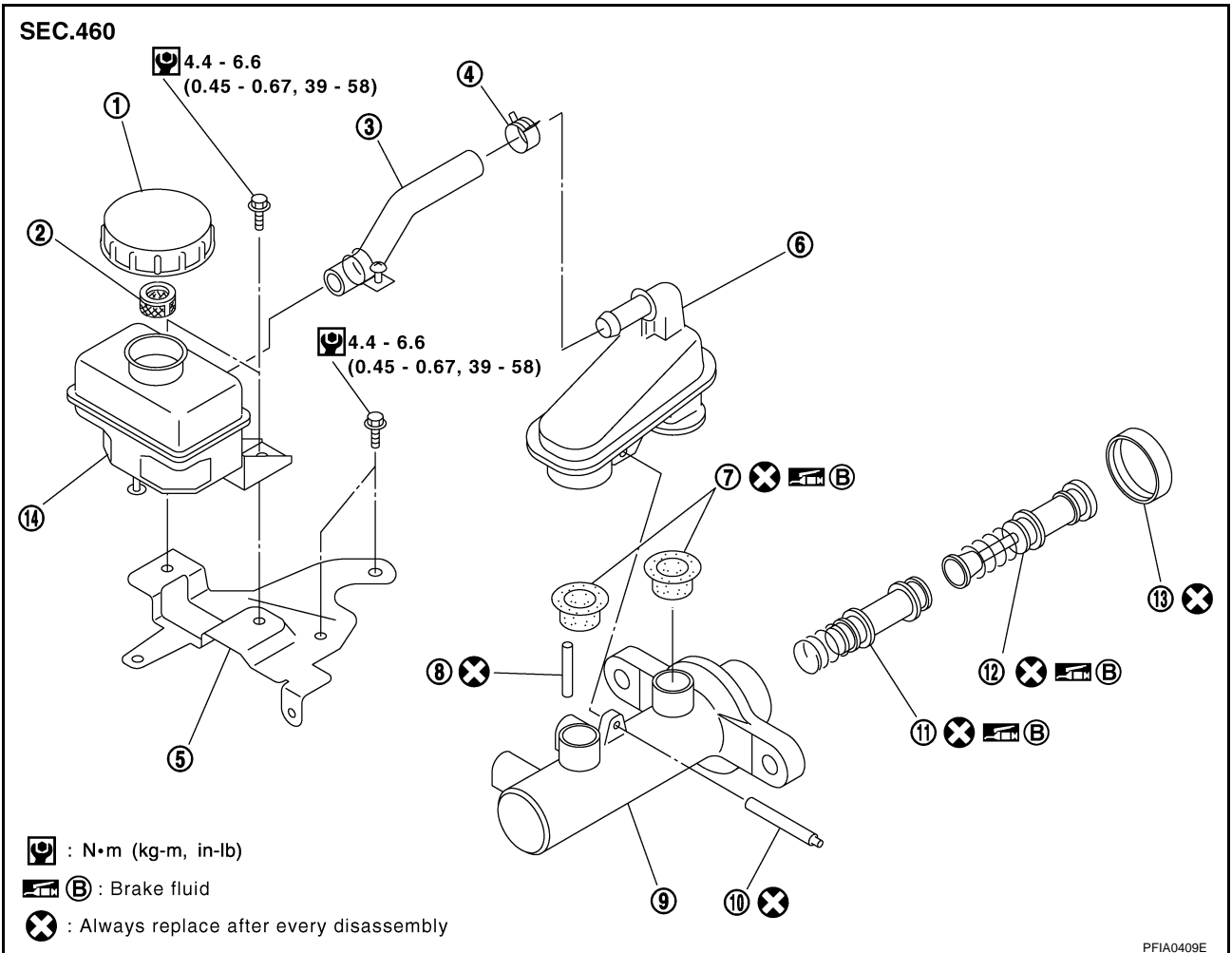

- |                  |                               |                             |
|------------------|-------------------------------|-----------------------------|
| 1. Reservoir cap | 2. Oil strainer               | 3. Hose and clamp           |
| 4. Clamp         | 5. Bracket                    | 6. Reservoir tank           |
| 7. Grommet       | 8. Piston stopper             | 9. Cylinder body            |
| 10. Pin          | 11. Secondary piston assembly | 12. Primary piston assembly |
| 13. Stopper cap  | 14. Sub tank                  |                             |

A  
B  
C  
D  
E  
BR  
G  
H  
I  
J  
K  
L  
M

# BRAKE MASTER CYLINDER

AFS00176

## Disassembly and Assembly WITHOUT VDC MODELS

### Disassembly

#### CAUTION:

Remove the reservoir tank only when absolutely necessary.

1. Using a flat-bladed screwdriver as shown in the figure, lift up the tabs on the stopper cap and remove it from the master cylinder. The piston inside the master cylinder might pop out when this is done, so hold the stopper cap down at the same time.

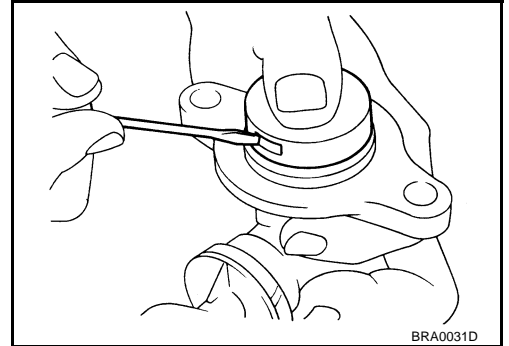

2. Place the side flange of cylinder body with chamfering around the pin insertion hole facing up, and firmly set master cylinder assembly in a vise.

#### CAUTION:

- When setting the master cylinder assembly with the vise, be sure not to over-tighten.
- When setting securing with a vise, use copper plates or cloth to protect the flange.

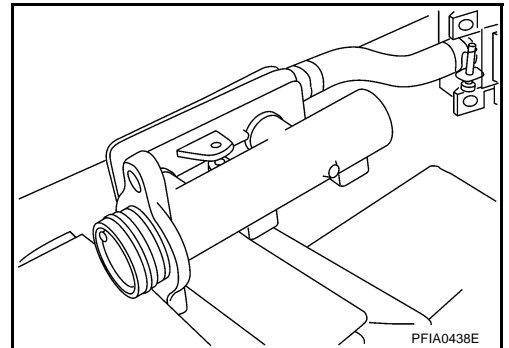

3. Using a pin punch [commercial service tool: diameter approximately 4 mm (0.16 in)], remove mounting pins on the reservoir tank.
4. Remove master cylinder assembly from vise.
5. Remove reservoir tank and grommet from cylinder body.

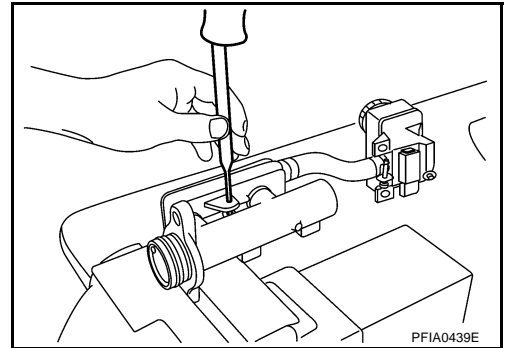

6. Using a flat-bladed screwdriver, push in the piston and remove piston stopper from cylinder body.
7. Carefully pull the primary piston assembly straight out to prevent cylinder inner wall from being damaged.

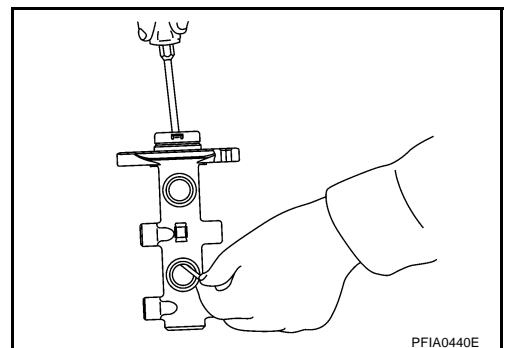

# BRAKE MASTER CYLINDER

8. Tap flange using a soft block such as wood, and carefully pull the secondary piston assembly straight out to prevent cylinder inner wall from being damaged.

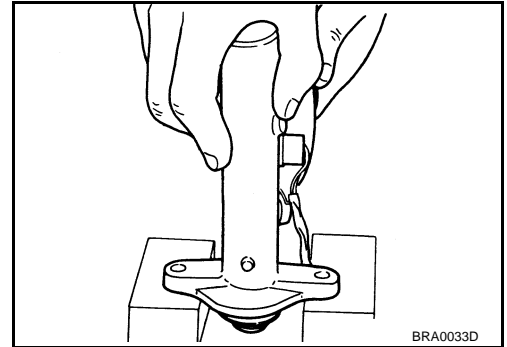

A  
B  
C  
D  
E

## Inspection After Disassembly

Master cylinder

- Check the inner wall of the cylinder for damage, abrasion, corrosion and pin holes. Replace the master cylinder if any non-standard condition is detected.

## Assembly

### CAUTION:

- Never use mineral oils such as kerosene, gasoline during the cleaning and assembly process.
- Make sure there is no foreign matter such as dirt or dust attached to the inner cylinder walls, the piston, or the cap seal, and take care to avoid damaging parts with the assembly tools.
- Do not drop parts. If a part is dropped, do not use it.

1. Apply brake fluid to cylinder inner wall body and contact surface of the piston assembly. Then insert secondary piston assembly and primary piston assembly into cylinder body in this order.

### CAUTION:

- Do not reuse primary and secondary piston assemblies.
- Be sure to replace the assembly without disassembling the new inner kit.
- Pay attention to the orientation of the piston cup, and insert straight to prevent the cup from being caught by cylinder inner wall.

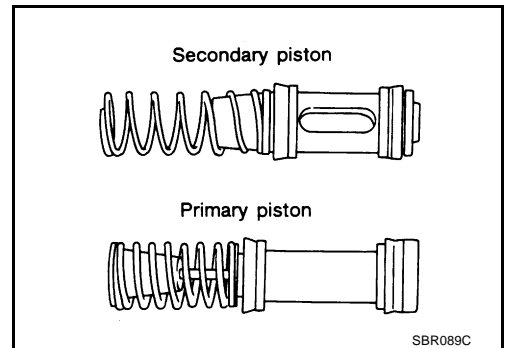

BR

G  
H  
I  
J  
K  
L  
M

2. Visually check the secondary piston slit through the tank boss hole on the secondary side of the cylinder body, and insert the piston stopper.

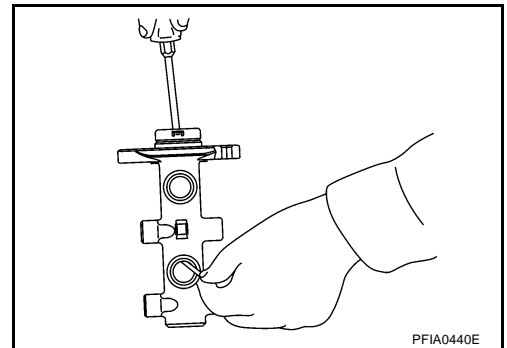

3. Holding down the primary piston with the stopper cap, push the stopper cap claws so they are firmly into the cylinder grooves, then install the stopper cap.

### CAUTION:

**Do not reuse the stopper cap.**

4. Apply brake fluid to the grommet and install to the cylinder body.

### CAUTION:

**Do not reuse the grommet.**

5. Master cylinder assembly is fixed in the vise as described in "disassembly: step 2".

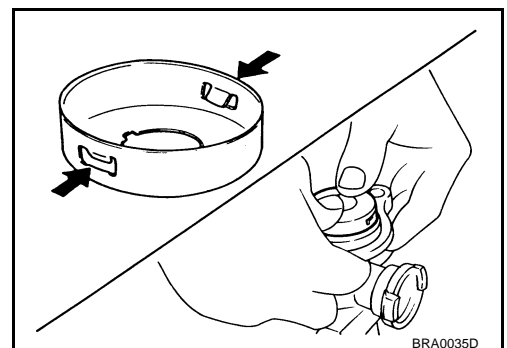

## BRAKE MASTER CYLINDER

- Using a pin punch [commercial service tool: diameter approx. 4 mm (0.16 in)], insert the reservoir tank mounting pin into the pin hole so that the attachment side and the opposite side are identical.

**CAUTION:**

**Do not reuse reservoir tank grommet and mounting pin.**

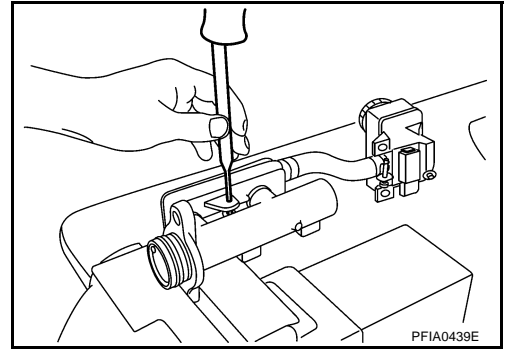

# BRAKE MASTER CYLINDER

## WITH VDC MODELS

### Disassembly

#### CAUTION:

- Master cylinder can not be disassembled.
  - Remove the reservoir tank only when absolutely necessary.
1. Remove clip.
  2. Remove reservoir tank and grommet from cylinder body.

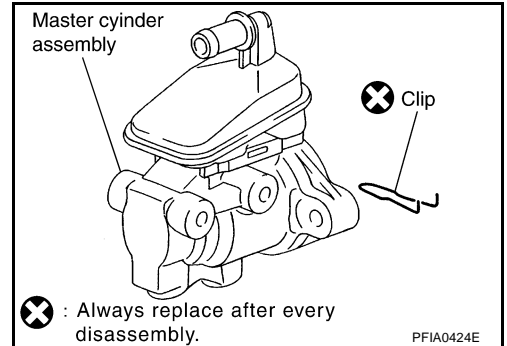

### Assembly

#### CAUTION:

- Do not use mineral oils such as kerosene, gasoline during the cleaning and assembly process.
  - Do not drop parts. If a part is dropped, do not use it.
1. Apply brake fluid the grommet and attach to the cylinder body.

#### CAUTION:

**Do not reuse the grommet.**

2. Install reservoir tank onto the cylinder body.
3. Insert the clip.

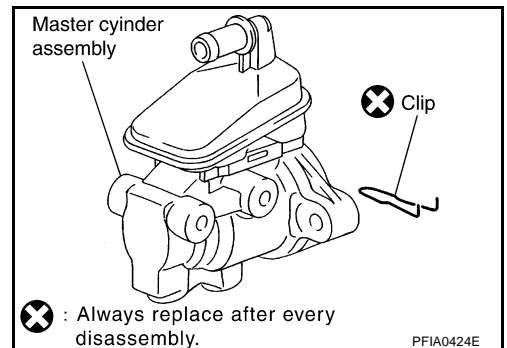

A

B

C

D

E

BR

G

H

I

J

K

L

M

# BRAKE BOOSTER

## BRAKE BOOSTER

PFP:47200

### On-Vehicle Service OPERATING CHECK

AFS00177

With the engine stopped, change the vacuum to the atmospheric pressure by depressing the brake pedal several times. Then with brake pedal fully depressed, start the engine and when the vacuum pressure reaches the standard, make sure the clearance between the brake pedal and floor panel decreases.

**CAUTION:**

Depressing pedal interval is approximately 5 seconds.

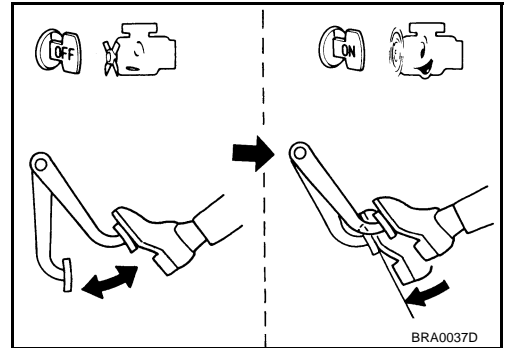

### AIRTIGHT CHECK

- Start engine, and stop it after 1 minute. Depress brake pedal several times slowly. The pedal should go further down the first tie, and then it should gradually rise thereafter.
- Depress brake pedal while engine is running, and stop engine with pedal depressed. The pedal stroke should not change after holding pedal down for 30 seconds.

**CAUTION:**

Depressing pedal interval is approximately 5 seconds.

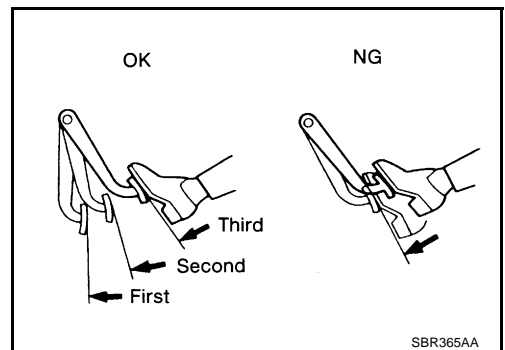

# BRAKE BOOSTER

## Removal and Installation

AFS00178

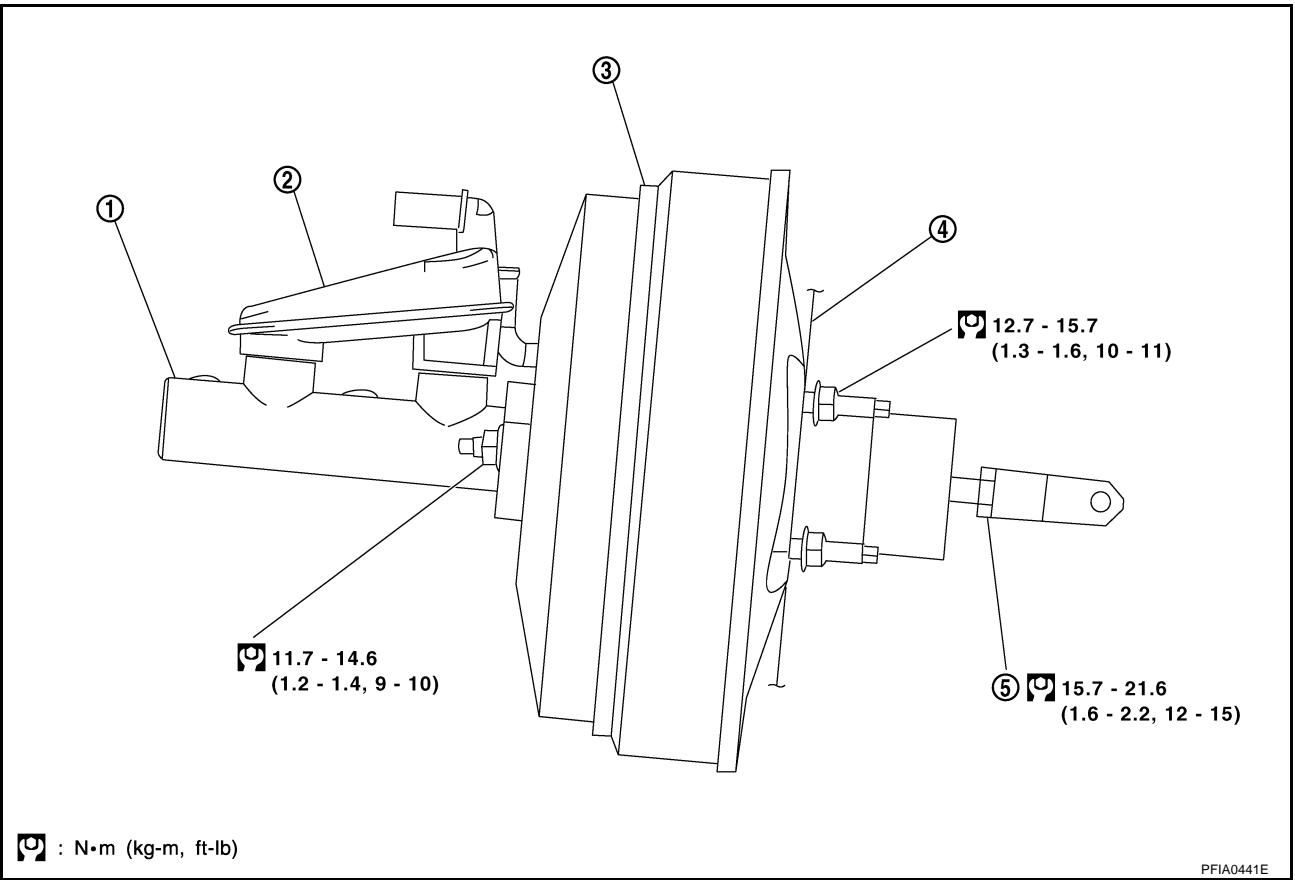

- 1. Master cylinder
- 4. Gasket

- 2. Reservoir tank
- 5. Lock nut

- 3. Brake booster

A  
B  
C  
D  
E  
BR  
G  
H  
I  
J  
K  
L  
M

# BRAKE BOOSTER

## REMOVAL

### CAUTION:

- Be careful not to deform or bend brake piping while removing and installing the brake booster.
  - Replace clevis pin if it is damaged.
  - Be careful not to damage brake booster stud bolt threads. If brake booster is tilted or inclined during installation, the dash panel may damage the threads.
  - Attach the check valve in the correct orientation.
1. Remove brake master cylinder. Refer to [BR-15, "BRAKE MASTER CYLINDER"](#)
  2. Remove cowl top cover. Refer to [EI-21, "COWL TOP"](#) .
  3. Remove vacuum hose from the brake booster. Refer to [BR-25, "VACUUM LINES"](#) .
  4. Remove the brake pedal snap pin and clevis pin from inside the vehicle.
  5. Remove brake tube bracket from dash panel.
  6. Remove nuts from the brake booster and brake pedal assembly.
  7. Remove brake booster assembly from the dash panel.

## INSPECTION AFTER REMOVAL

### Output Rod Length Inspection

1. Using a handy vacuum pump, apply a vacuum of  $-66.7 \text{ kPa}$  ( $-500 \text{ mmHg}$ ,  $-19.69 \text{ inHg}$ ) to the brake booster.
2. Check output rod length.

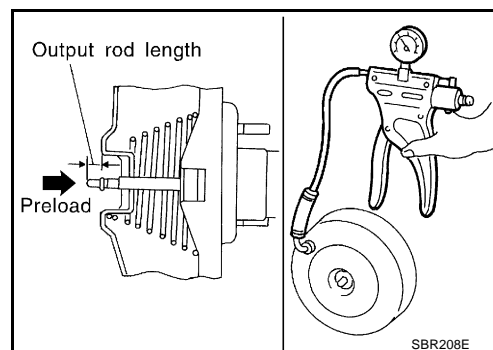

**Standard dimension when applying a vacuum of  $-66.7 \text{ kPa}$  ( $-500 \text{ mmHg}$ ,  $-19.69 \text{ inHg}$ ):**

**Without VDC models : 10.4mm (0.409 in)**

**With VDC models :  $-15.7\text{mm}$  ( $-0.6181 \text{ in}$ )**

## INSTALLATION

1. Loosen the lock nut to adjust the input rod length so that the length B (in the figure) satisfies the specified value.

**Length "B" : 125 mm (4.92 in)**

2. After adjusting "B", temporarily tighten the lock nut to install the booster assembly to the vehicle. At this time, securely install a gasket between the booster assembly and the dash panel.
3. Connect the brake pedal with the clevis of the input rod.
4. Install the pedal bracket mounting nuts and tighten them to the specified torque.
5. Install the master cylinder to the booster assembly. Refer to [BR-15, "Removal and Installation"](#) .
6. Adjust the height and play of the brake pedal.
7. Tighten the lock nut of the input rod to the specified torque.
8. Install vacuum hose to brake booster. Refer to [BR-25, "VACUUM LINES"](#) .
9. Install brake tube bracket to dash panel.
10. Install cowl top cover. Refer to [EI-21, "COWL TOP"](#) .
11. Refill new brake fluid and bleed air. Refer to [BR-12, "Bleeding Brake System"](#) .

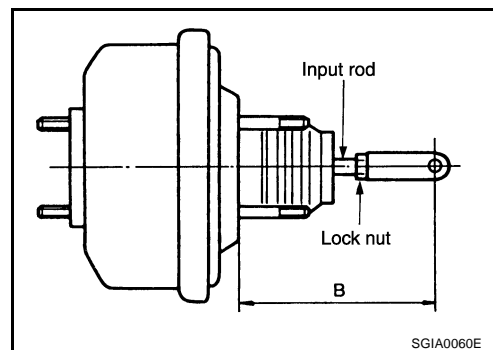



# VACUUM LINES

## VACUUM LINES

PFP:41920

### Removal and Installation

AFS00179

A  
B  
C  
D  
E  
BR  
G  
H  
I  
J  
K  
L  
M

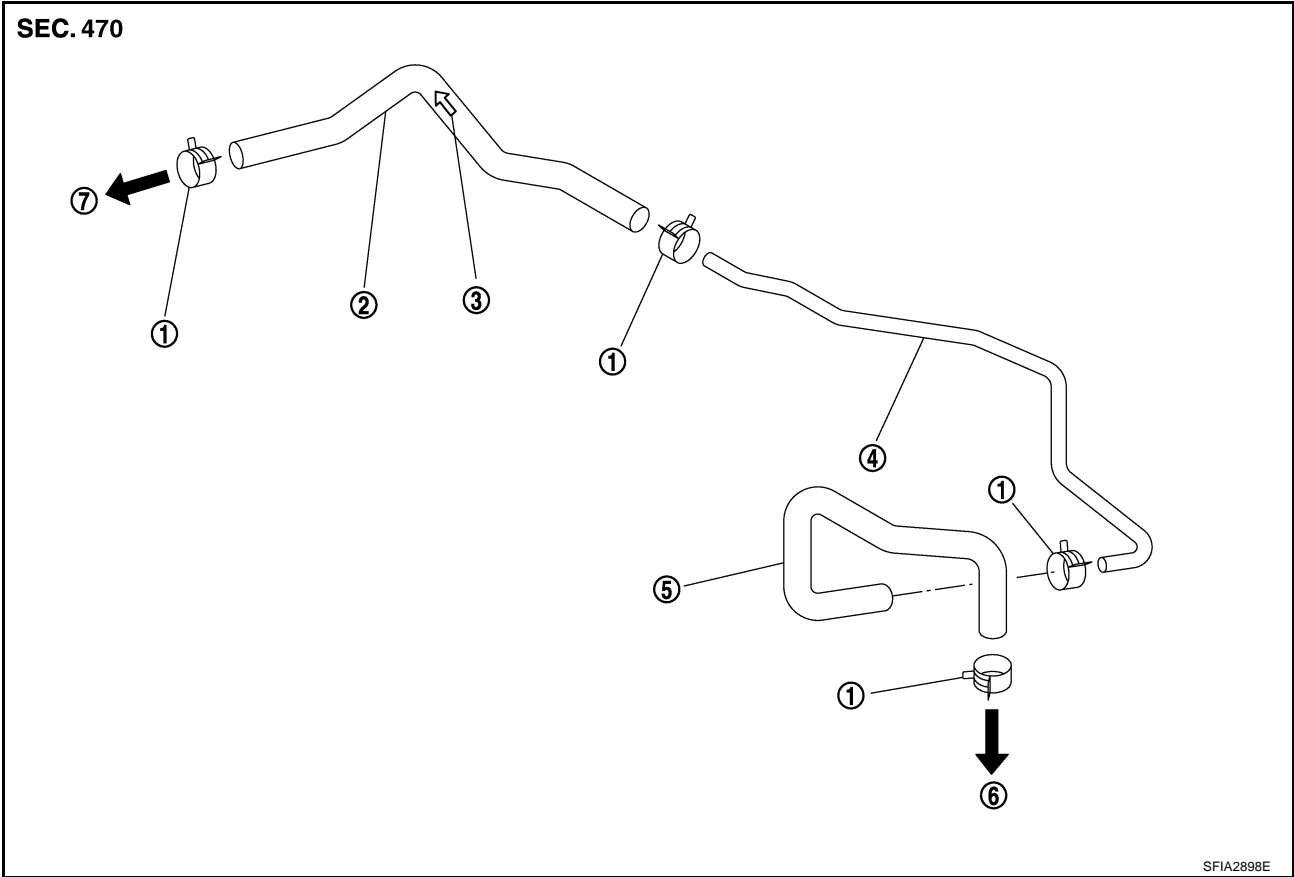

- 1. Clamp
- 2. Vacuum hose
- 3. Engine side indicator stamp (built-in check valve)
- 4. Vacuum tube
- 5. Vacuum hose
- 6. To brake booster
- 7. To intake manifold

#### CAUTION:

- Because vacuum hose contains a check valve, it must be installed in the correct orientation. Refer to the stamp or label to confirm correct installation. The brake booster will not operate normally if the hose is installed in the wrong direction.
- Insert the vacuum hose for at least 24 mm (0.94 in).
- Do not use lubricating oil during assembly.

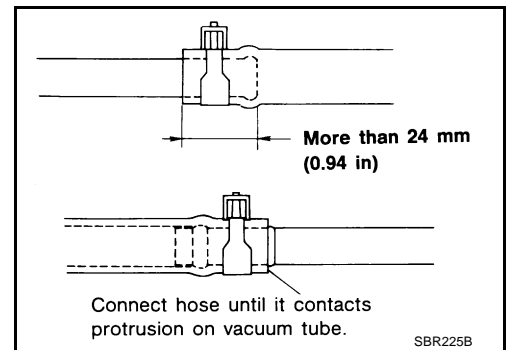

### Inspection VISUAL INSPECTION

AFS0017A

Check vacuum hose and connections for air tightness, improper attachment, chafing and deterioration. Repair or replace as necessary.

# VACUUM LINES

## CHECK VALVE INSPECTION

### Airtightness Inspection

Check vacuum with a handy vacuum pump.

#### Connected to booster side (1):

Vacuum decrease should be within 1.3 kPa (10 mmHg, 0.39 inHg) for 15 seconds under a vacuum of -66.7 kPa (-500 mmHg, -19.69 inHg)

#### Connected to engine side (2):

Vacuum should not exist.

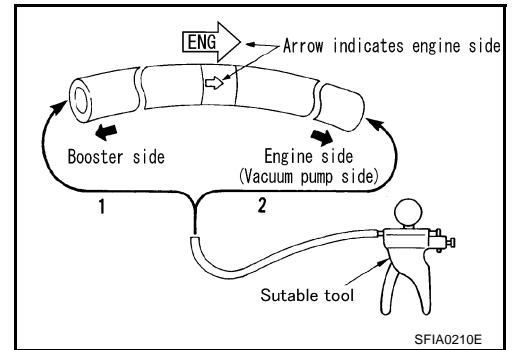

# FRONT DISC BRAKE

## FRONT DISC BRAKE

PFP:41000

### On-Board Inspection PAD WEAR INSPECTION

AFS0017B

- Check the thickness of the pad from inspection hole of the cylinder body. Use a scale for inspection if necessary.

**Standard thickness : 9.5 mm (0.374 in)**

**Repair limit thickness : 2.0 mm (0.079 in)**

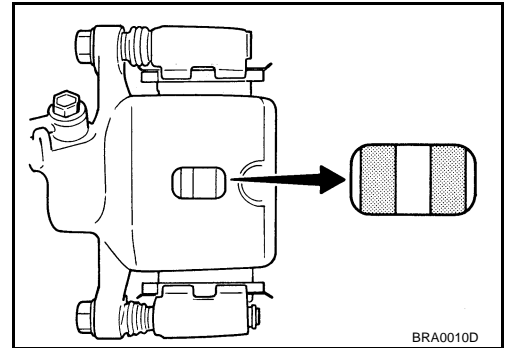

## Components

AFS0017C

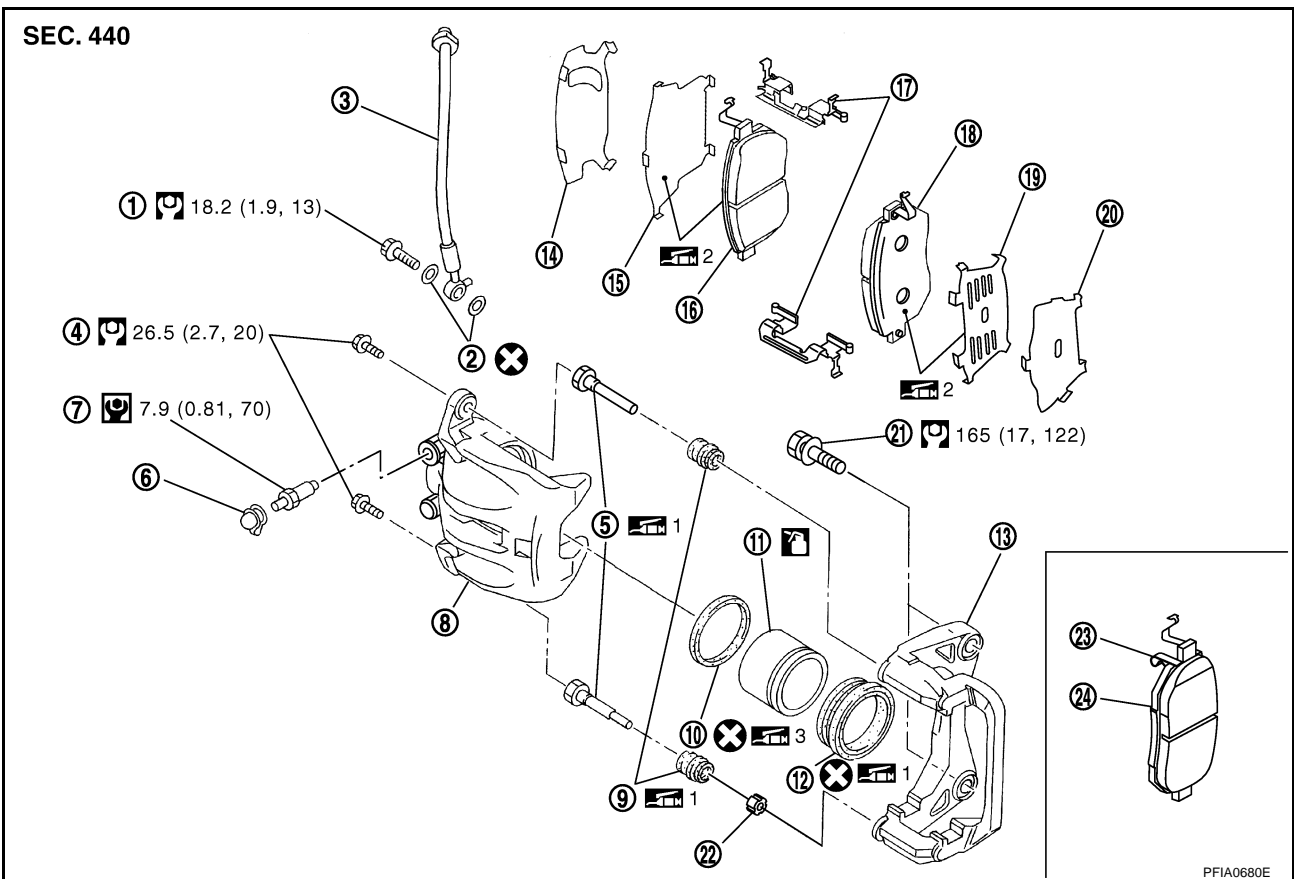

- |                     |                      |                               |
|---------------------|----------------------|-------------------------------|
| 1. Union bolt       | 2. Copper washer     | 3. Brake hose                 |
| 4. Sliding pin bolt | 5. Sliding pin       | 6. Cap                        |
| 7. Bleed valve      | 8. Cylinder body     | 9. Sliding pin boot           |
| 10. Piston seal     | 11. Piston           | 12. Piston boot               |
| 13. Torque member   | 14. Inner shim cover | 15. Inner shim                |
| 16. Inner pad       | 17. Pad retainer     | 18. Outer pad                 |
| 19. Outer shim      | 20. Outer shim cover | 21. Torque member fixing bolt |
| 22. Bushing         | 23. Pad wear sensor  | 24. Inner pad (RH)            |

Refer to [GI-10, "Components"](#) and the followings for the symbols in the figure.

1: Apply rubber grease.

2: Apply PBC (Poly Butyl Cuprysil) grease or silicone-based grease.

# FRONT DISC BRAKE

 3: Apply polyglycol ether based lubricant.

 : Apply brake fluid.

## WARNING:

- Clean dust on caliper and brake pad with a vacuum dust collector to minimize the hazard of air borne particles or other materials.

## CAUTION:

- While removing cylinder body, never depress the brake pedal because the piston will pop out.
- It is not necessary to remove bolts on torque member and brake hose except for disassembly or replacement of the caliper assembly. In this case, suspend cylinder body with wire so as not to stretch brake hose.
- Do not damage piston boot.
- If any shim is subject to serious corrosion, replace it with a new one.
- Always replace shims and shim covers as a set when replacing brake pads.
- Burnish the brake contact surface after refinishing or replacing rotors, after replacing pads, or if a soft pedal occurs at very low mileage. Refer to [BR-32, "BRAKE BURNISHING PROCEDURE"](#).

## Removal and Installation of Brake Pad

AFS0017D

### REMOVAL

1. Remove tires from vehicle with power tool.
2. Remove lower sliding pin bolt.
3. Suspend cylinder body with a wire and remove the pad and shim from the torque member.

### CAUTION:

When removing the pad retainer from the torque member, lift the pad retainer in the arrow direction (shown in the figure) so as not to deform it.

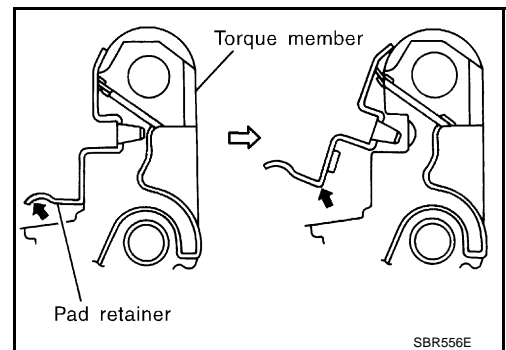

### INSTALLATION

1. Attach the inner shim and shim cover to the inner pad and the outer shim to the outer pad.
2. Push the piston in so that the pad is attached and then attach the cylinder body to the torque member.

### NOTE:

Using a disc brake piston tool (commercial service tool), etc., makes it easier to push in the piston.

### CAUTION:

- By pushing in the piston, the brake fluid returns to the master cylinder reservoir tank. Watch the level of the surface of the reservoir tank.
  - When attaching the pad retainer, attach it firmly so that it does not float up higher than the torque member, as shown in the figure.
3. Install lower sliding pin bolt, and tighten it to the specified torque.
  4. Check brake for drag.
  5. Install the tires to the vehicle.

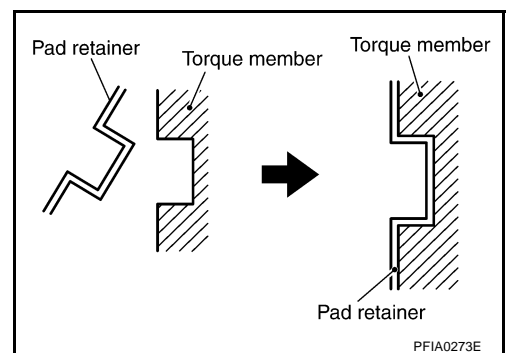

## Removal and Installation of Brake Caliper Assembly

AFS0017E

### REMOVAL

1. Remove tires from vehicle with a power tool.
2. Drain brake fluid. Refer to [BR-11, "Drain and Refill"](#).

# FRONT DISC BRAKE

3. Remove union bolts and torque member bolts, and remove brake caliper assembly.
4. Remove disc rotor.

## INSTALLATION

### CAUTION:

- Refill with new brake fluid "DOT3"
- Do not reuse drained brake fluid.

1. Install disc rotor.
2. Install caliper assembly to the vehicle, and tighten bolts to the specified torque.

 : 145 – 185 N·m (15 – 18 kg·m, 107 – 136 ft·lb)

### CAUTION:

Before installing caliper assembly to the knuckle, wipe off oil from the knuckle spindle washers and mounting surface of caliper assembly.

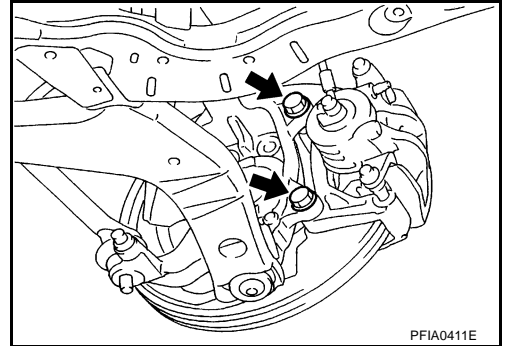

3. Install brake hose to the brake caliper assembly, and tighten union bolts to the specified torque.

 : 16.7 – 19.6 N·m (1.7 – 1.9 kg·m, 13 – 14 ft·lb)

### CAUTION:

- Do not reuse the copper washer for union bolts.
- Attach the brake hose to the brake hose mounting boss.

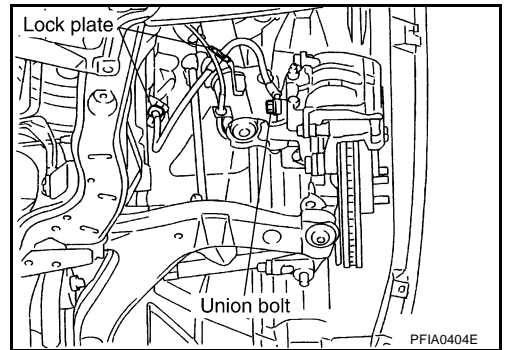

4. Refill new brake fluid and bleed air. Refer to [BR-12, "Bleeding Brake System"](#).
5. Install the tires to the vehicle.

## Disassembly and Assembly of Brake Caliper Assembly

AFS0017F

### DISASSEMBLY

1. Remove slide pin bolts, and then remove the pads, shim, shim cover, and pad retainers from torque member.

### CAUTION:

When removing the pad retainer from the torque member, lift it in the direction indicated by the arrow in the figure so that it does not deform.

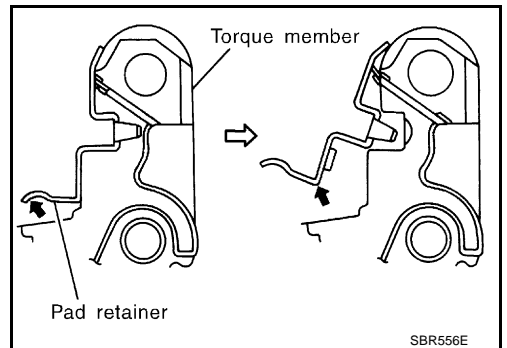

2. Remove sliding pins and sliding pin boots from torque member.

## FRONT DISC BRAKE

3. Place a wooden block as shown in the figure, and blow air from union bolt mounting hole to remove piston and piston boot.

**CAUTION:**

**Do not get your fingers caught in the piston.**

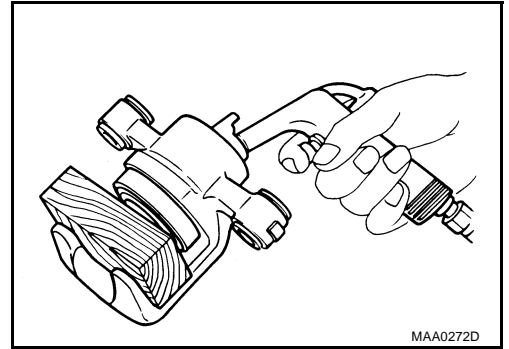

4. Using a flat-bladed screwdriver, remove the piston seal from the cylinder body.

**CAUTION:**

**Be careful not to damage cylinder inner wall.**

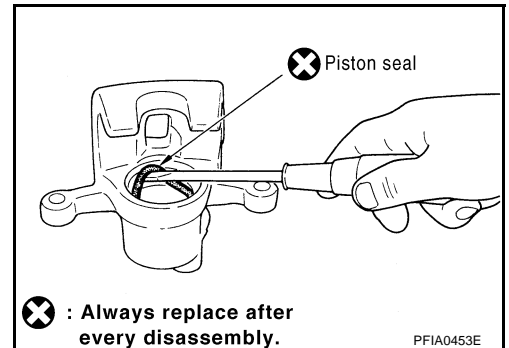

### CALIPER INSPECTION

#### Cylinder Body

**CAUTION:**

- Use new brake fluid to clean. Do not use mineral oils such as gasoline or kerosene.
- Check inside surface of cylinder for score, rust, wear, damage or presence of foreign materials. If any of the above conditions are observed, replace cylinder body.
- Minor damage from rust or foreign materials may be eliminated by polishing surface with a fine emery paper. Replace cylinder body if necessary.

#### Torque Member

Check for wear, cracks, and damage. If damage or deformation is present, replace the affected part.

#### Piston

**CAUTION:**

- Piston sliding surface is plated, do not polish with emery paper even if rust or foreign materials are stuck to sliding surface.
- Check piston for score, rust, wear, damage or presence of foreign materials. Replace if any of the above conditions are observed.

Check piston surface for corrosion, wear, and damage. If any non-standard condition is detected, replace applicable part.

#### Sliding Pin, and Sliding Pin Boot

Check sliding pin and sliding pin boot for wear, damage, and cracks. If damage or deformation is present, replace the applicable part.

### ASSEMBLY

**CAUTION:**

**When assembling, use only rubber lubricant specified below.**

# FRONT DISC BRAKE

1. Apply polyglycol ether based lubricant to the piston seal, and install them to the cylinder body.

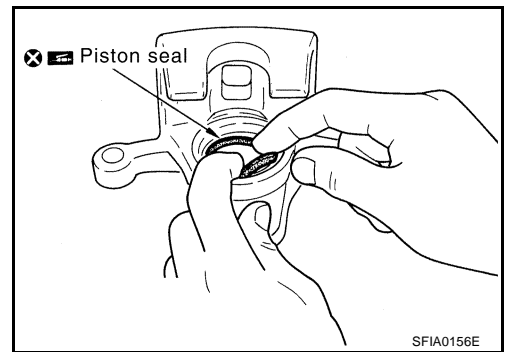

2. Apply brake fluid or rubber grease to the piston boot, place it on the piston, and insert the piston boot cylinder-side lip into the cylinder body groove.

**CAUTION:**

**Do not reuse the piston boot.**

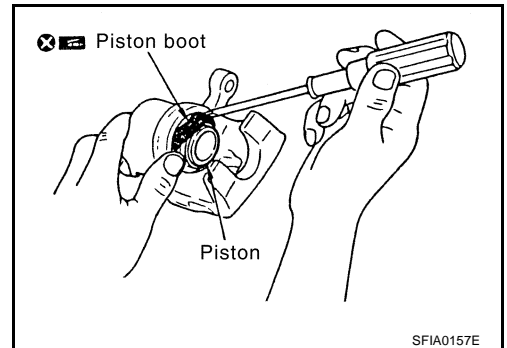

3. Insert the piston boot piston-side lip into the piston groove.

**CAUTION:**

**Press the piston evenly and vary the pressing point to prevent cylinder inner wall from being rubbed.**

4. Install sliding pins and sliding pin boots to torque member.

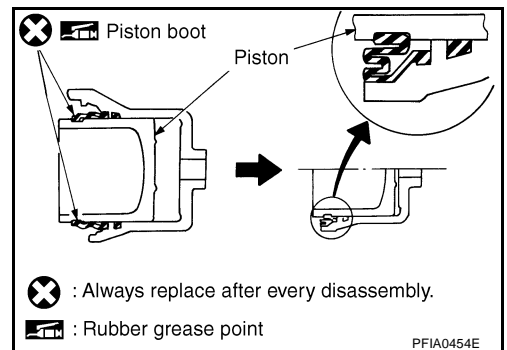

5. Attach the inner shim and shim cover to the inner pad and the outer shim to the outer pad.
6. Install cylinder body. Tighten sliding pin bolt to the specified torque.

## DISC ROTOR INSPECTION

### Visual Inspection

Check surface of the disc rotor for uneven wear, cracks, and serious damage. If any of them is detected, replace applicable part.

### Runout Inspection

1. Using wheel nuts, fix disc rotor to the wheel hub. (2 or more positions)
2. Check runout using a dial indicator.  
[measured at 10 mm (0.39 in) inside the disc edge]

**Maximum runout : 0.04 mm (0.0016 in)**  
**(with it attached to the vehicle)**

**NOTE:**

Make sure that wheel bearing axial end play is within the specifications before measuring runout. Refer to [FAX-5, "FRONT WHEEL HUB AND KNUCKLE"](#).

3. If runout is outside the limit, find the minimum runout point by shifting mounting positions of the disc rotor and wheel hub by one hole.

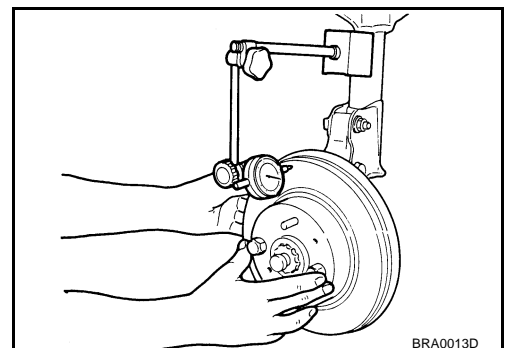

# FRONT DISC BRAKE

4. If runout still out of specification, turn rotor with on-car brake lathe ("MAD, DL-8700", "AMMCO 700 and 705" or equivalent).

## Thickness Inspection

Using a micrometer, check thickness of the disc rotor. If thickness is outside the standard, replace disc rotor.

<b>Standard thickness</b>	<b>: 28.0 mm (1.102 in)</b>
<b>Repair limit thickness</b>	<b>: 26.0 mm (1.024 in)</b>
<b>Thickness variation (measured at 8 positions)</b>	<b>: 0.015 mm (0.0006 in)</b>

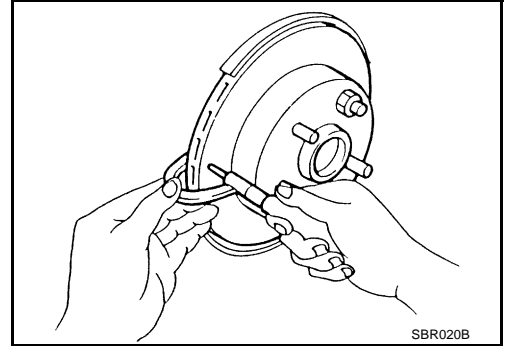

## BRAKE BURNISHING PROCEDURE

Burnish the brake contact surface according to the following procedure after refinishing or replacing rotors, after replacing pads, or if a soft pedal occurs at very low mileage.

### **CAUTION:**

**Only perform this procedure under safe road and traffic conditions. Use extreme caution.**

- 1. Drive the vehicle on a straight smooth road at 50 km/h (31 MPH).**
- 2. Use medium brake pedal /foot effort to bring the vehicle to a complete stop from 50 km/h (31 MPH). Adjust brake pedal /foot pressure such that vehicle stopping time equals 3 to 5 seconds.**
- 3. To cool the brake system, drive the vehicle at 50 km/h (31 MPH) for 1 minute without stopping.**
- 4. Repeat steps 1 to 3, 10 times or more to complete the burnishing procedure.**



# REAR DISC BRAKE

## REAR DISC BRAKE

PFP:44000

### On-Board Inspection PAD WEAR INSPECTION

AFS0017L

- Check the thickness of the pad from inspection hole of the cylinder body inspection hole. Use a scale for inspection if necessary.

**Standard thickness : 8.5 mm (0.335 in)**

**Repair limit thickness : 2.0 mm (0.079 in)**

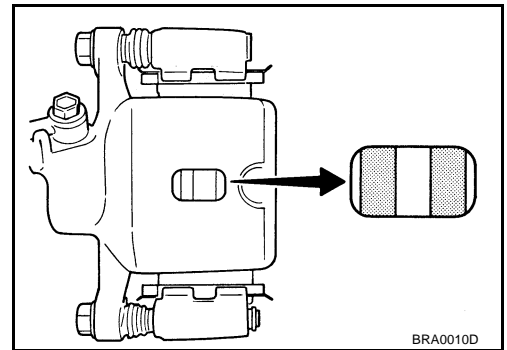

BRA0010D

## Components

AFS0017M

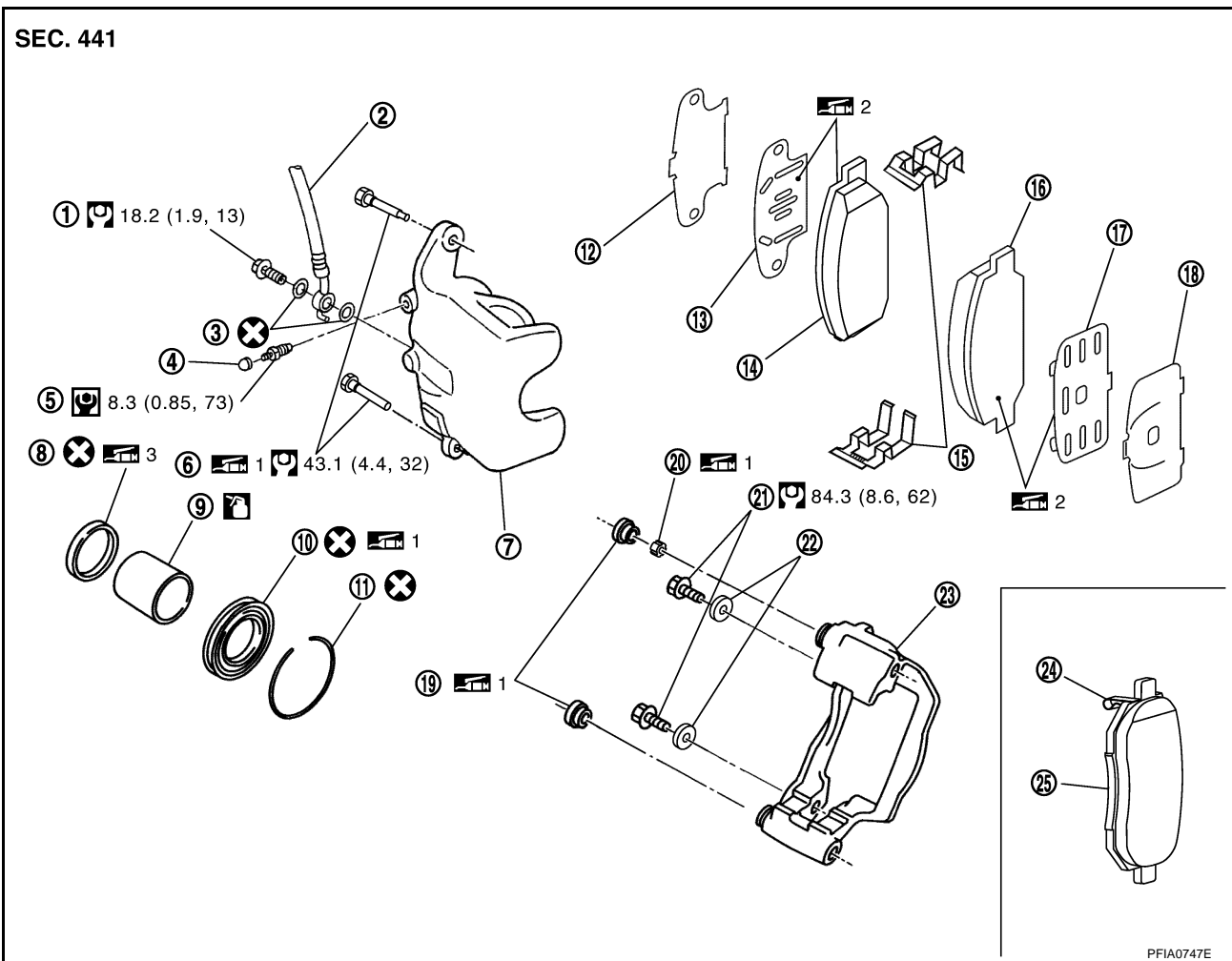





PFA0747E

- |                    |                    |                               |
|--------------------|--------------------|-------------------------------|
| 1. Union bolt      | 2. Brake hose      | 3. Copper washer              |
| 4. Cap             | 5. Bleed valve     | 6. Sliding pin bolt           |
| 7. Cylinder body   | 8. Piston seal     | 9. Piston                     |
| 10. Piston boot    | 11. Retaining ring | 12. Inner shim cover          |
| 13. Inner shim     | 14. Inner pad      | 15. Pad retainer              |
| 16. Outer pad      | 17. Outer shim     | 18. Outer shim cover          |
| 19. Slide pin boot | 20. Bushing        | 21. Torque member fixing bolt |
| 22. Washer         | 23. Torque member  | 24. Pad wear sensor           |
| 25. Inner pad (RH) |                    |                               |

# REAR DISC BRAKE

Refer to [GI-10, "Components"](#) and the followings for the symbols in the figure.

-  1: Apply rubber grease.
-  2: Apply PBC (Poly Butyl Cuprysil) grease or silicone based grease.
-  3: Apply polyglycol ether based lubricant.
-  : Apply brake fluid.

## WARNING:

- Clean dust on caliper and brake pad with a vacuum dust collector to minimize the hazard of air borne particles or other materials.

## CAUTION:

- While removing cylinder body, never depress the brake pedal because the piston will pop out.
- It is not necessary to remove bolts on torque member and brake hose except for disassembly or replacement of the caliper assembly. In this case, suspend cylinder body with a wire so as not to stretch brake hose.
- Do not damage piston boot.
- If any shim is subject to serious corrosion, replace it with a new one.
- Always replace shims and shim covers as a set when replacing brake pads.
- Burnish the brake contact surface after refinishing or replacing rotors, after replacing pads, or if a soft pedal occurs at very low mileage. Refer to [BR-38, "BRAKE BURNISHING PROCEDURE"](#) .

## Removal and Installation of Brake Pad

AFS0017N

### REMOVAL

1. Remove tires from vehicle with power tool.
2. Remove sliding pin bolt (one on top).
3. Suspend cylinder body with a wire, and remove pads, pad retainers, shims from torque member.

### INSTALLATION

1. Apply PBC (Poly Butyl Cuprysil) grease or silicon-based grease to the rear of the pad and to both sides of the shim, and attach the inner shim and shim cover to the inner pad, and the outer shim and outer shim cover to the outer pad.
2. Attach the pad retainer and pad to the torque member.
3. Push the piston in so that the pad is attached and attach the cylinder body to the torque member.

#### NOTE:

Using a disc brake piston tool (commercial service tool), etc., makes it easier to push in the piston.

#### CAUTION:

**By pushing in the piston, the brake fluid returns to the master cylinder reservoir tank. Watch the level of the surface of the reservoir tank.**

4. Install the sliding pin bolt (one on top) and tighten to the specified torque.
5. Check brake for drag.
6. Install the tires to the vehicle.

## Removal and Installation of Brake Caliper Assembly

AFS0017O

### REMOVAL

1. Remove tires from vehicle with power tool.
2. Drain brake fluid. Refer to [BR-11, "Drain and Refill"](#) .
3. Remove union bolts and torque member bolts, and remove brake caliper assembly.
4. Remove disc rotor.

### INSTALLATION

#### CAUTION:

- Refill with new brake fluid "DOT 3".
  - Do not reuse drained brake fluid.
1. Install disc rotor.

# REAR DISC BRAKE

2. Install caliper assembly to the vehicle, and tighten bolts to the specified torque.

 : 71.6 - 97.0 N-m (7.3 - 9.8 kg-m, 53 - 71 ft-lb)

**CAUTION:**

Before installing caliper assembly to the vehicle, wipe off oil and grease on washer seats on axle assembly and mounting surface of caliper assembly.

3. Install brake hose to caliper assembly and tighten union bolts to the specified torque.

 : 16.7 - 19.6 N-m (1.7 - 1.9 kg-m, 13 - 14 ft-lb)

**CAUTION:**

- Do not reuse the copper washer for union bolts.
- Attach brake hose to the brake hose mounting boss.

4. Refill new brake fluid and bleed air. Refer to [BR-12, "Bleeding Brake System"](#).
5. Install the tires to the vehicle.

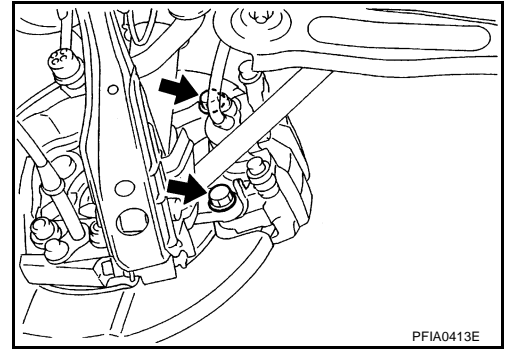

A  
B  
C  
D  
E

BR

## Disassembly and Assembly of Brake Caliper Assembly

AFS0017P

### DISASSEMBLY

1. Remove slide pin bolt, and then remove the pads, shims, shim covers, and pad retainers from torque member and cylinder.
2. Remove sliding pin boots from torque member.
3. As shown in the figure, using a flat-bladed screwdriver, remove retaining ring from cylinder body.

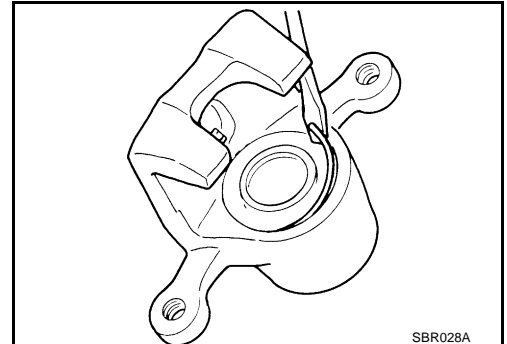

G  
H  
I  
J  
K  
L  
M

4. Place a wooden block as shown in the figure, and blow air from union bolt mounting hole to remove pistons and piston boots.

**CAUTION:**

Do not get your fingers caught in the piston.

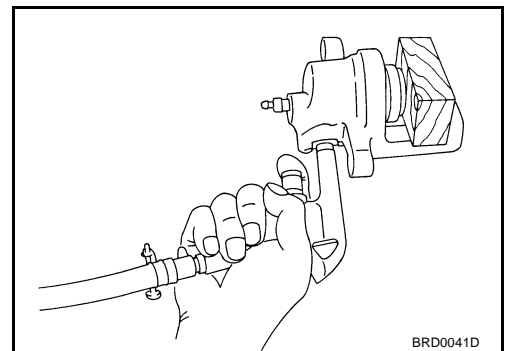

## REAR DISC BRAKE

- Using a flat-bladed screwdriver, remove piston seals from cylinder body.

**CAUTION:**

Be careful not to damage cylinder inner wall.

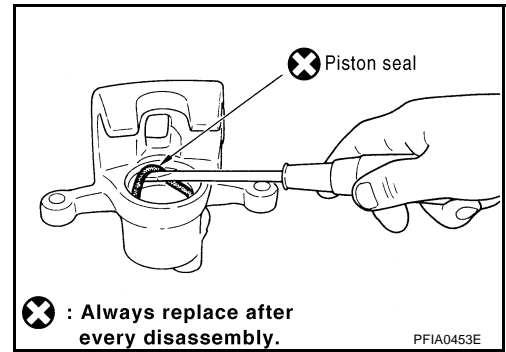

### CALIPER INSPECTION

#### Cylinder Body

**CAUTION:**

- Use new brake fluid to clean. Do not use mineral oils such as gasoline or kerosene.
- Check inside surface of cylinder for score, rust, wear, damage or presence of foreign materials. If any of these conditions are observed, replace cylinder body.
- Minor damage from rust or foreign materials may be eliminated by polishing surface with a fine emery paper. Replace cylinder body if necessary.

#### Torque Member

Check for wear, cracks, and damage. If damage or deformation is present, replace the affected part.

#### Piston

**CAUTION:**

- Piston sliding surface is plated, do not polish with emery paper even if rust or foreign materials are stuck to sliding surface.
- Check piston for score, rust, wear, damage or presence of foreign materials. Replace if any of these conditions are observed.

#### Sliding Pin and Sliding Pin Boot

Check sliding pin and sliding pin boot for wear, damage, and cracks. If damage or deformation is present, replace the applicable part.

### ASSEMBLY

**CAUTION:**

When assembling, use only rubber lubricant specified below.

- Apply polyglycol ether based lubricant to the piston seal, and install them to the cylinder body.

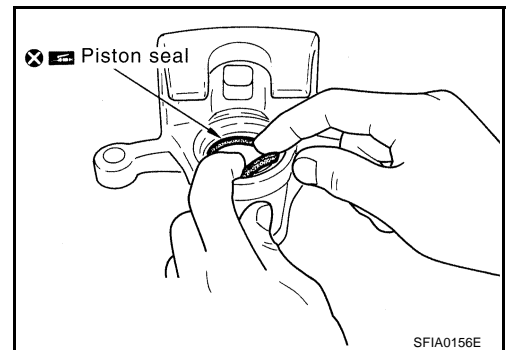

## REAR DISC BRAKE

- Apply brake fluid or rubber grease to the piston boot, place it on the piston, and insert the piston boot cylinder-side lip into the cylinder body groove.

**CAUTION:**

**Do not reuse the piston boot.**

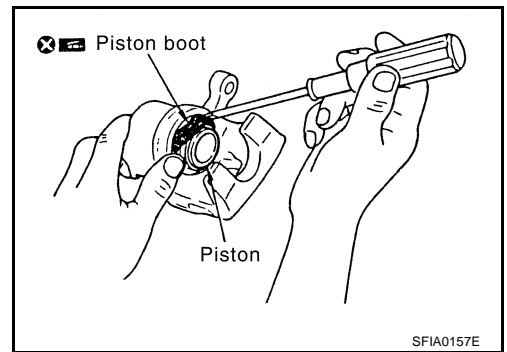

- Insert the piston boot piston-side lip into the piston groove.

**CAUTION:**

**Press the piston evenly and vary the pressing point to prevent cylinder inner wall from being rubbed.**

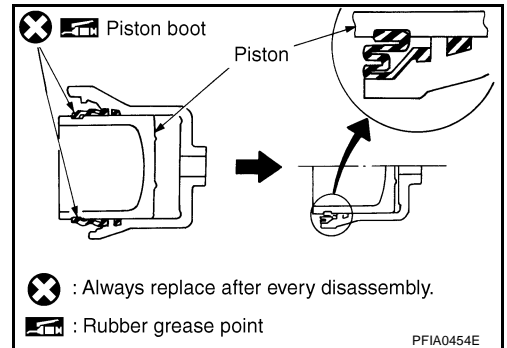

- Fix piston boot with retaining ring.

**CAUTION:**

- **Make sure the boot is firmly in the cylinder body groove.**
- **Do not reuse the retaining ring.**

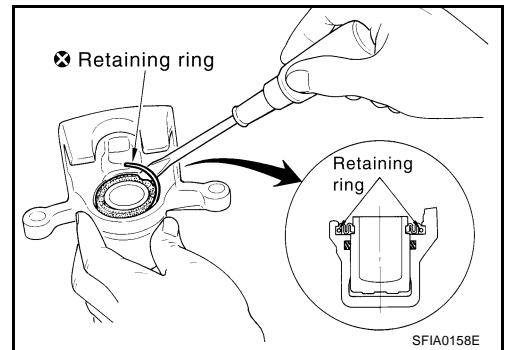

- Install the sliding pin bolt and sliding pin boot to the torque member.
- Apply PBC (Poly Butyl Cuprysil) grease or silicon-based grease to the rear of the pad and to both sides of the shim, and attach the inner shim and shim cover to the inner pad, and the outer shim and outer shim cover to the outer pad.
- Install the pad retainer and pad to the torque member.

**CAUTION:**

**When installing the pad retainer, install it firmly so that it does not float up from groove of the torque member, as shown in the figure.**

- After assembling shims and shim covers to pad, install it to the torque member.
- Install cylinder body. Tighten sliding pin bolts to the specified torque.

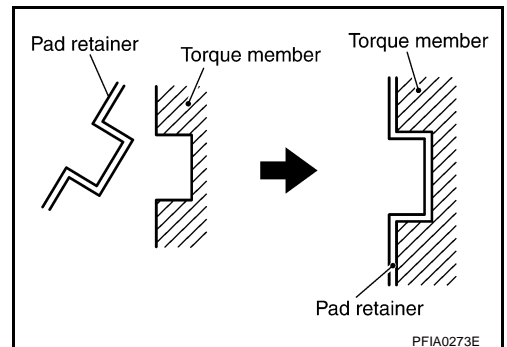

# REAR DISC BRAKE

## DISC ROTOR INSPECTION

### Visual Inspection

Check surface of the disc rotor for uneven wear, cracks, and serious damage. If any of them is detected, replace applicable part.

### Runout Inspection

1. Using wheel nuts, fix disc rotor to the wheel hub. (2 or more positions)
2. Check runout using a dial indicator.  
[measured at 10 mm (0.39 in) inside the disc edge]

**Maximum runout : 0.05 mm (0.0020 in)**  
**(with it attached to the vehicle)**

#### NOTE:

Make sure that wheel bearing axial end play is within the specifications before measuring runout. Refer to [RAX-5. "WHEEL HUB"](#).

3. If runout is outside the limit, find the minimum runout point by shifting mounting positions of the disc rotor and wheel hub by one hole.
4. If runout is still out of specification, turn rotor with on-car brake lathe ("MAD, DL-8700", "AMMCO 700 and 705 " or equivalent).

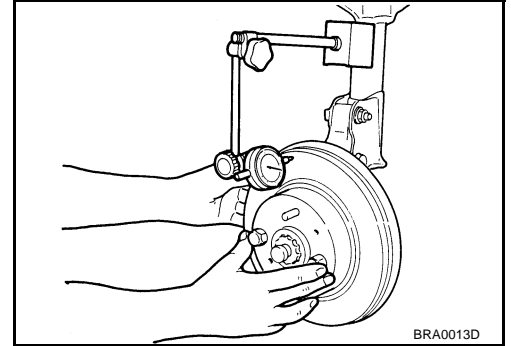

### Thickness Inspection

Using a micrometer, check thickness of the disc rotor. If thickness is outside the standard, replace disc rotor.

**Standard thickness : 16.0 mm (0.630 in)**  
**Repair limit : 14.0 mm (0.551 in)**  
**Thickness variation : 0.015 mm (0.0006 in)**  
**(measured at 8 positions)**

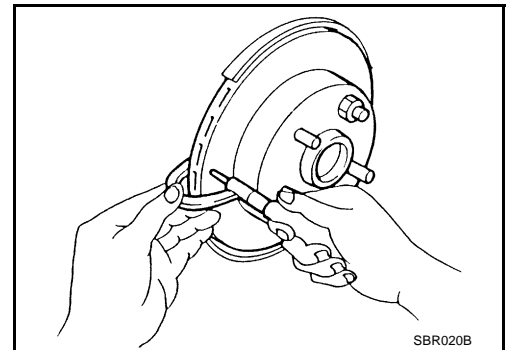

## BRAKE BURNISHING PROCEDURE

Burnish the brake contact surface according to the following procedure after refinishing or replacing rotors, after replacing pads, or if a soft pedal occurs at very low mileage.

### CAUTION:

**Only perform this procedure under safe road and traffic conditions. Use extreme caution.**

1. Drive the vehicle on a straight smooth road at 50 km/h (31 MPH).
2. Use medium brake pedal /foot effort to bring the vehicle to a complete stop from 50 km/h (31 MPH). Adjust brake pedal /foot pressure such that vehicle stopping time equals 3 to 5 seconds.
3. To cool the brake system, drive the vehicle at 50 km/h (31 MPH) for 1 minute without stopping.
4. Repeat steps 1 to 3, 10 times or more to complete the burnishing procedure.

# SERVICE DATA AND SPECIFICATIONS (SDS)

## SERVICE DATA AND SPECIFICATIONS (SDS)

PPF:00030

### General Specifications

AFS0017V

Unit: mm (in)

Front brake	Brake model		CLZ31VB
	Cylinder bore diameter		63.6 (2.504)
	Pad Length × width × thickness		111 × 63.5 × 9.5 (4.37 × 2.500 × 0.374)
	Rotor outer diameter × thickness		320 × 28 (12.60 × 1.10)
Rear brake	Brake model		AD14VE
	Cylinder bore diameter		42.86 (1.6874)
	Pad Length × width × thickness		83.0 × 33.0 × 8.5 (3.268 × 1.299 × 0.335)
	Rotor outer diameter × thickness		308 × 16 (12.13 × 0.63)
Master cylinder	Cylinder bore diameter		25.4 (0.10)
Control valve	Valve model		Electric brake force distribution
Brake booster	Booster model		C215T
	Diaphragm diameter	primary	228.5 (9.0)
		Secondary	203 (8.0)
Recommended brake fluid			DOT 3

### Brake Pedal

AFS0017W

Brake pedal height (from dash panel top surface)	199.5 - 209.5 mm (7.85 - 8.25 in)
Depressed pedal height [under a force of 490 N (50 kg, 110 lb) with the engine running]	More than 120 mm (4.72 in)
Clearance between the stopper rubber and the threaded end of the stop lamp switch	0.74 - 1.96 mm (0.0291 - 0.0772 in)
Pedal play	3 - 11 mm (0.12 - 0.43 in)

### Brake Booster Vacuum type

AFS0017X

Input rod installation standard dimension	125 mm (4.92 in)
---	------------------

### Check Valve

AFS0017Y

Vacuum leakage [at vacuum of -66.7 kPa (-500 mmHg, -19.69 inHg)]	Within 1.3 kPa (10 mmHg, 0.39 inHg) of vacuum for 15 seconds
---	--

### Front Disc Brake

AFS0017Z

Brake model		CLZ31VB
Brake pad	Standard thickness (new)	9.5 mm (0.374 in)
	Repair limit thickness	2.0 mm (0.079 in)
Disc rotor	Standard thickness (new)	28.0 mm (1.102 in)
	Repair limit thickness	26.0 mm (1.024 in)
	Thickness variation (measured at 8 positions)	0.015 mm (0.0006 in)
	Maximum runout (with it attached to the vehicle)	0.04 mm (0.0016 in)

### Rear Disc Brake

AFS00180

Brake model		AD14VE
Brake pad	Standard thickness (new)	8.5 mm (0.335 in)
	Repair limit thickness	2.0 mm (0.079 in)

## SERVICE DATA AND SPECIFICATIONS (SDS)

Brake model		AD14VE
Disc rotor	Standard thickness (new)	16.0 mm (0.630 in)
	Repair limit thickness	14.0 mm (0.551 in)
	Thickness variation (measured at 8 positions)	0.015 mm (0.0006 in)
	Maximum runout (with it attached to the vehicle)	0.05 mm (0.0020 in)