

SECTION **RAX**  
REAR AXLE

A  
B  
C

RAX

CONTENTS

E

<b>PRECAUTIONS</b> .....	2	<b>REAR DRIVE SHAFT</b> .....	7	F
Caution .....	2	Removal and Installation .....	7	
<b>PREPARATION</b> .....	3	REMOVAL .....	7	
Commercial Service Tools .....	3	INSPECTION AFTER REMOVAL .....	7	G
<b>NOISE, VIBRATION AND HARSHNESS (NVH)</b>		INSTALLATION .....	7	
<b>TROUBLESHOOTING</b> .....	4	Disassembly and Assembly .....	8	
NVH Troubleshooting Chart .....	4	DISASSEMBLY .....	8	H
<b>WHEEL HUB</b> .....	5	INSPECTION AFTER DISASSEMBLY .....	9	
On-Vehicle Inspection and Service .....	5	ASSEMBLY .....	10	
WHEEL BEARING INSPECTION .....	5	<b>SERVICE DATA AND SPECIFICATIONS (SDS) .....</b>	<b>13</b>	I
Removal and Installation .....	5	Wheel Bearing .....	13	
REMOVAL .....	5	Drive Shaft .....	13	J
INSPECTION AFTER REMOVAL .....	6			
INSTALLATION .....	6			K

J  
K  
L  
M

# PRECAUTIONS

---

## PRECAUTIONS

PFP:00001

### Caution

ADS000B7

Observe the following precautions when disassembling and servicing drive shaft.

- Perform work in a location which is as dust-free as possible.
- Before disassembling and servicing, clean the outside of parts.
- Prevention of the entry of foreign objects must be taken into account during disassembly of the service location.
- Disassembled parts must be carefully reassembled in the correct order. If work is interrupted, a clean cover must be placed over parts.
- Paper shop cloths must be used. Fabric shop cloths must not be used because of the danger of lint adhering to parts.
- Disassembled parts (except for rubber parts) should be cleaned with kerosene which shall be removed by blowing with air or wiping with paper shop cloths.

# PREPARATION

## PREPARATION

PFP:00002

### Commercial Service Tools

ADS000B9

A  
B  
C  
RAX  
E  
F  
G  
H  
I  
J  
K  
L  
M

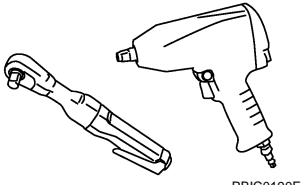
Tool name	Description
Power tool	 <ul style="list-style-type: none"><li>● Removing wheel nuts</li><li>● Removing brake caliper assembly</li><li>● Removing suspension links</li><li>● Removing drive shaft fixing bolts and nuts</li></ul>

RAX

# NOISE, VIBRATION AND HARSHNESS (NVH) TROUBLESHOOTING

## NOISE, VIBRATION AND HARSHNESS (NVH) TROUBLESHOOTING

PFP:00003

### NVH Troubleshooting Chart

ADS000BA

Use chart below to help you find the cause of the symptom. If necessary, repair or replace these parts.

Reference page			—	RAX-9	—	RAX-5	—	NVH in PR section	NVH in RFD section	NVH in FAX and FSU sections	Refer to REAR AXLE in this chart.	NVH in WT section	NVH in WT section	Refer to DRIVE SHAFT in this chart.	NVH in BR section	NVH in PS section	
Possible cause and SUSPECTED PARTS			Excessive joint angle	Joint sliding resistance	Imbalance	Improper installation, looseness	Parts interference	PROPELLER SHAFT	DIFFERENTIAL	FRONT AXLE AND FRONT SUSPENSION	REAR AXLE	TIRES	ROAD WHEEL	DRIVE SHAFT	BRAKES	STEERING	
Symptom	DRIVE SHAFT	Noise	x	x				x	x	x	x	x	x		x	x	
		Shake	x		x			x		x	x	x	x		x	x	
	REAR AXLE	Noise				x	x	x	x	x		x	x	x	x	x	x
		Shake				x	x	x		x		x	x	x	x	x	x
		Vibration				x	x	x		x		x		x			x
		Shimmy				x	x				x		x	x		x	x
		Judder				x					x		x	x		x	x
		Poor quality ride or handling				x	x				x		x	x			

x: Applicable

# WHEEL HUB

## WHEEL HUB

PF:43202

### On-Vehicle Inspection and Service

ADS000BB

Make sure the mounting conditions (looseness, back lash) of each component and component status (wear, damage) are normal.

### WHEEL BEARING INSPECTION

- Move wheel hub in the axial direction by hand. Make sure there is no looseness of wheel bearings.

**Axial end play : 0.05 mm (0.002 in) or less**

- Rotate wheel hub and make sure there is no unusual noise or other irregular conditions. If there are any irregular conditions, replace wheel hub and bearing assembly.

### Removal and Installation

ADS000BC

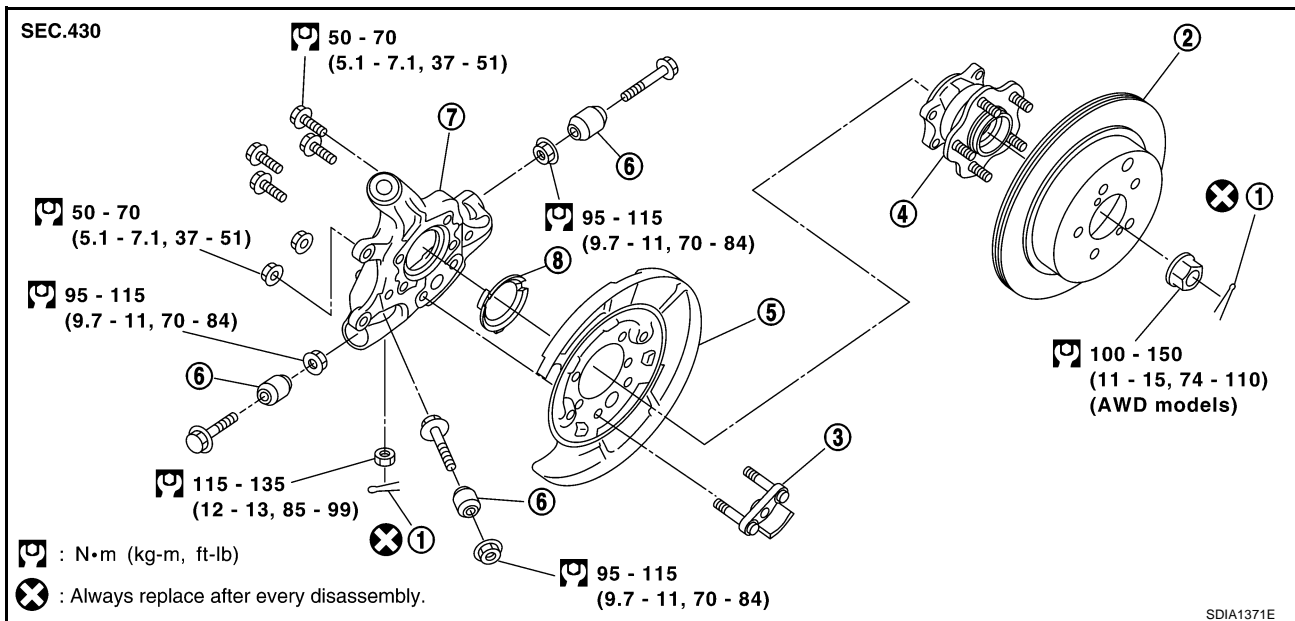

- |                                   |  |                 |
|-----------------------------------|--|-----------------|
| 1. Cotter pin (AWD models)        | 2. Disc rotor  | 3. Anchor block |
| 4. Wheel hub and bearing assembly | 5. Back plate  | 6. Bushing      |
| 7. Axle                           | 8. Axle cap (2WD models)<br>Dust shield (AWD models) |                 |

### REMOVAL

1. Remove tire with power tool.
2. Remove brake caliper with power tool. Hang it in a place where it will not interfere with work. Refer to [BR-34, "Removal and Installation of Brake Caliper Assembly"](#).

#### CAUTION:

- Avoid depressing brake pedal while brake caliper is removed.

3. Put alignment marks on disc rotor and wheel hub and bearing assembly, then remove disc rotor.

4. Remove wheel sensor from axle. Refer to [BRC-64, "WHEEL SENSORS"](#).

#### CAUTION:

Do not pull on wheel sensor harness.

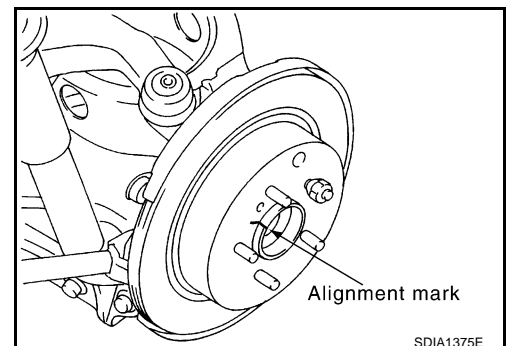

5. Remove parking cable and parking brake shoe from back plate. Refer to [PB-5, "PARKING BRAKE SHOE"](#)

# WHEEL HUB

6. Remove cotter pin. Then remove lock nut from drive shaft. (AWD models)
7. Using a puller (suitable tool), remove wheel hub and bearing assembly from drive shaft. (AWD models)  
**CAUTION:**
  - When removing axle, do not apply an excessive angle to drive shaft joint. Also be careful not to excessively extend slide joint.
  - Do not allow drive shaft to hang down without support for counter shaft, wheel joints, and other parts.
8. Remove fixing bolts of wheel hub and bearing assembly, then remove wheel hub and bearing assembly from axle.
9. Loosen fixing bolts and nuts of front lower link, radius rod and rear lower link in side of suspension member.
10. Remove shock absorber fixing bolt (lower), front lower link fixing bolt and nut (axle-side) while supporting rear lower link with jack.
11. Remove fixing bolt and nut in axle side of rear lower link with power tool. Then remove coil spring.
12. Remove fixing bolt and nut in axle side of radius rod with power tool.
13. Remove suspension arm and cotter pin at axle, then loosen mounting nut.
14. Use a ball joint remover (suitable tool) to remove suspension arm from axle. Be careful not to damage ball joint boot.  
**CAUTION:**  
To prevent damage to threads and to prevent ball joint remover (suitable tool) from coming off suddenly, and temporarily tighten mounting nut.
15. Remove axle from vehicle.
16. Remove fixing nuts of anchor block, then remove anchor block and back plate from axle.
17. Remove axle cap (2WD) or dust shield (AWD) from axle.

## INSPECTION AFTER REMOVAL

Check for deformity, cracks and damage on each parts, replace if necessary.

### Ball Joint Inspection

- Check for boot breakage, axial looseness, and torque of suspension arm ball joint. Refer to [RSU-11, "SUSPENSION ARM"](#).

## INSTALLATION

- Refer to [RAX-5, "Removal and Installation"](#) for tightening torque. Install in the reverse order of removal.

### NOTE:

Refer to component parts location and do not reuse non-reusable parts.

- To assemble disc rotor and wheel hub and bearing assembly, align the marks.  
(When not using the alignment mark, refer to [BR-38, "DISC ROTOR INSPECTION"](#).)
- Perform final tightening of installation position of suspension links (rubber bushing) under unladen conditions with tires on level ground. Check wheel alignment. Refer to [RSU-5, "Wheel Alignment Inspection"](#).

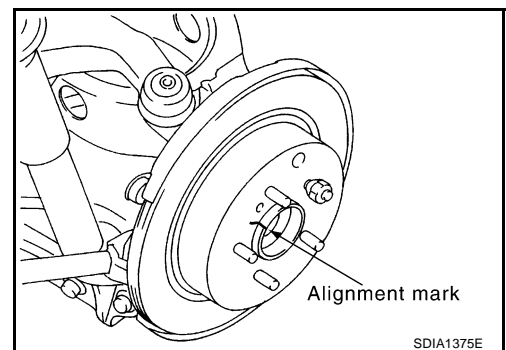

# REAR DRIVE SHAFT

## REAR DRIVE SHAFT

PFP:39600

### Removal and Installation

ADS000BE

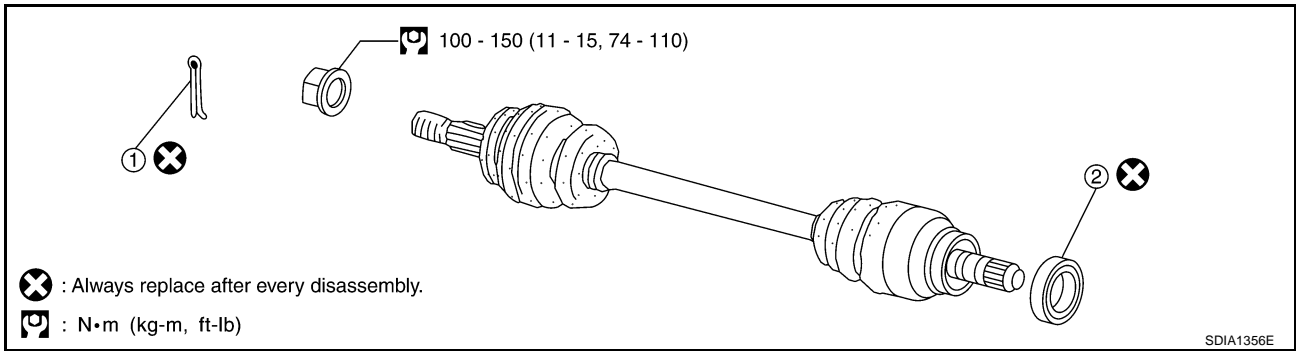

A  
B  
C  
RAX

1. Cotter pin

2. Dust shield

### REMOVAL

1. Remove tire with power tool.
  2. Remove wheel sensor from axle. Refer to [BRC-64, "WHEEL SENSORS"](#).
- CAUTION:**  
**Do not pull on wheel sensor harness.**
3. Remove cotter pin. Then remove lock nut from drive shaft.
  4. Remove parking cable and parking brake shoe from back plate. Refer to [PB-5, "PARKING BRAKE SHOE"](#).
  5. Remove wheel hub and bearing assembly fixing bolts, then remove wheel hub and bearing assembly from axle. Refer to [RAX-5, "Removal and Installation"](#).
  6. Use a wheel wrench or other tool to remove drive shaft from final drive.

E  
F  
G  
H  
I  
J  
K  
L

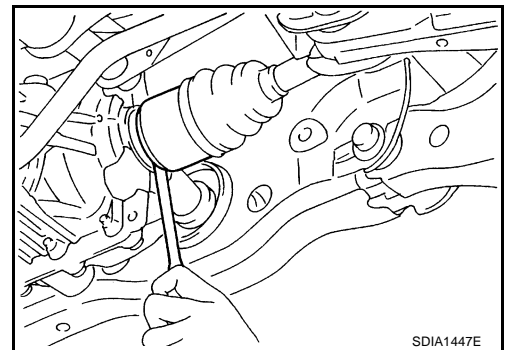

### INSPECTION AFTER REMOVAL

- Move joint in the up/down, left/right, and axial direction. Check for any rough movement or significant looseness.
- Check boot for cracks or other damage, and also for grease leakage.
- If a trouble is found, disassemble drive shaft, and then replace with new one.

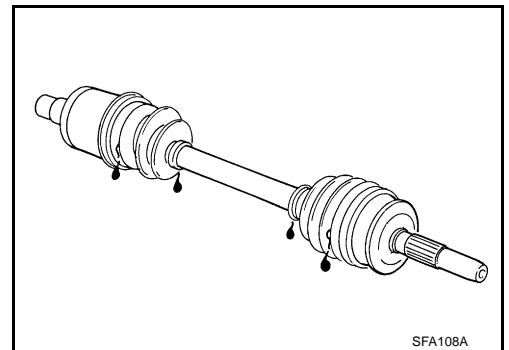

M

### INSTALLATION

- Refer to [RAX-7, "Removal and Installation"](#) for tightening torque. Install in the reverse order of removal.
- CAUTION:**  
**Refer to component parts location and do not reuse non-reusable parts.**

# REAR DRIVE SHAFT

- In order to prevent damage to final drive side oil seal, first fit to protector onto oil seal before inserting drive shaft. Slide drive shaft into slide joint tap with a hammer to install securely.

**CAUTION:**

Be sure to make sure circular clip is securely fastened.

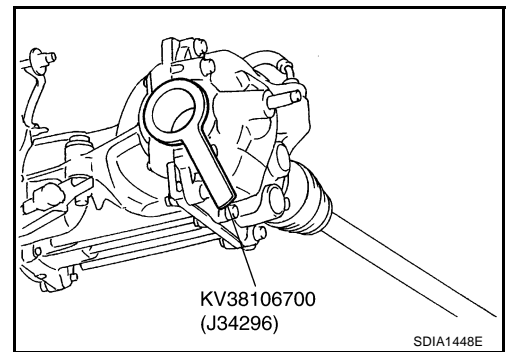

## Disassembly and Assembly

ADS000BF

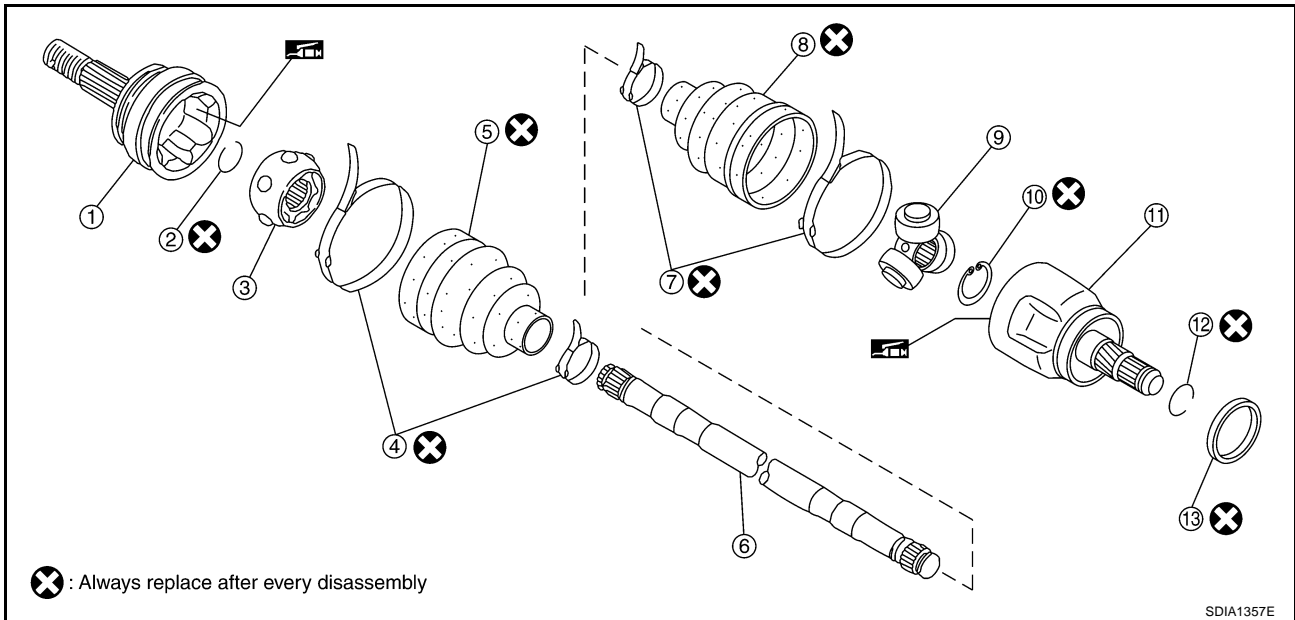

- |                                 |                            |   |
|---------------------------------|----------------------------|---|
| 1. Joint sub-assembly           | 2. Circular clip           | 3. Ball cage/Steel ball/Inner race assembly |
| 4. Boot band (Wheel side)       | 5. Boot (Wheel side)       | 6. Shaft                                    |
| 7. Boot band (Final drive side) | 8. Boot (Final drive side) | 9. Spider assembly                          |
| 10. Snap ring                   | 11. Slide joint assembly   | 12. Circular clip                           |
| 13. Dust shield                 |                            |   |

### DISASSEMBLY

#### Final Drive Side

- Press shaft in a vise.
- Remove boot band.

**CAUTION:**

When retaining shaft in a vice, always use copper or aluminum plates between vise and shaft.

- Put matching marks on slide joint assembly and shaft before separating slide joint assembly.
- Put matching marks on spider assembly and shaft.

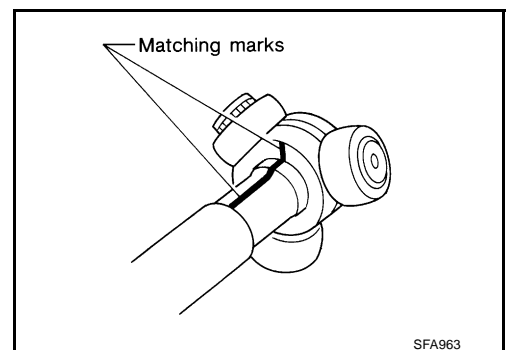



## REAR DRIVE SHAFT

5. Remove snap ring, then remove spider assembly from shaft.

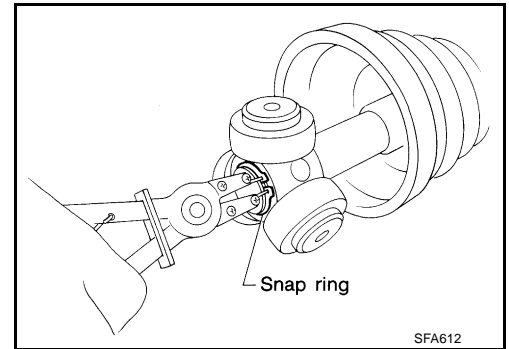

6. Remove boot from shaft.
7. Remove old grease on slide joint assembly with paper towels.
8. Remove circular clip and dust shield from slide joint assembly.

### Wheel Side

1. Place shaft in a vise.

#### **CAUTION:**

**When retaining shaft in a vise, always use copper or aluminum plates between vise and shaft.**

2. Remove boot bands. Then remove boot from joint sub-assembly.
3. Screw a drive shaft puller (suitable tool) 30 mm (1.18 in) or more into threaded part of joint sub-assembly. Pull joint sub-assembly out of shaft.

#### **CAUTION:**

- If joint sub-assembly cannot be removed after five or more unsuccessful attempts, replace the entire drive shaft assembly.
- Align sliding hammer and drive shaft and remove them by pulling directly.

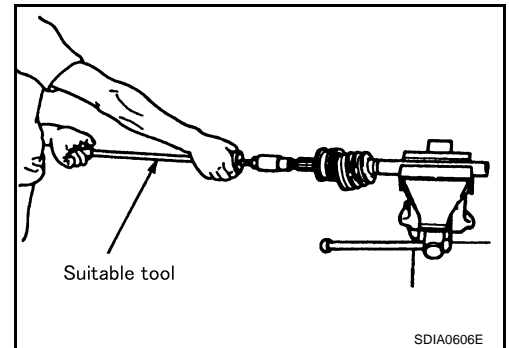

4. Remove boot from shaft.
5. Remove circular clip from shaft.
6. While rotating ball cage, remove old grease on joint sub-assembly with paper towels.

### INSPECTION AFTER DISASSEMBLY

#### Shaft

- Replace drive shaft if there is any runout, cracking, or other damage.

#### Joint Sub-Assembly

- Make sure there is no rough rotation or unusual axial looseness.
- Make sure there is no foreign material inside joint sub-assembly.
- Check joint sub-assembly for compression scars, cracks or fractures.

#### **CAUTION:**

**If there are any irregular conditions of joint sub-assembly components, replace the entire joint sub-assembly.**

#### Slide Joint Side

##### Housing

- Make sure there are compression scars, cracks, fractures or unusual wear of ball rolling surface.
- Make sure there is no damage to shaft threads.
- Make sure there is no deformation of boot installation parts.

#### Ball Cage

- Make sure there compression scars, cracks or fractures of sliding surface.

# REAR DRIVE SHAFT

## Steel Ball

- Make sure there are compression scars, cracks, fractures or unusual wear.

## Inner Race

- Check ball sliding surface for compression scars, cracks or fractures.
- Make sure there is no damage to serrated part.

### CAUTION:

If there are any irregular conditions in the component, replace with a new set of housing, ball cage, steel ball and inner race.

## ASSEMBLY

### Final Drive Side

1. Install new boot and new small boot band on shaft.

### CAUTION:

- Cover shaft serration with tape to prevent damage to boot during installation.
2. Remove protective tape wound around serrated part of shaft.

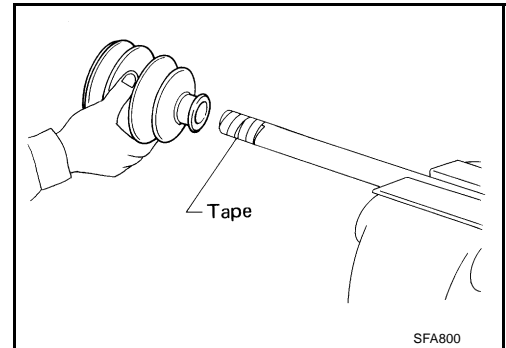

3. Install spider assembly securely, making sure the matching marks which were made during disassembly are properly aligned.
4. Install new snap ring.

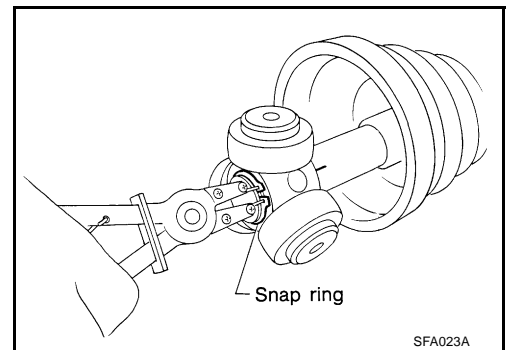

5. Insert the amount of new grease (NISSAN genuine grease or equivalent) listed below into housing from large end of boot.

**Grease amount : 85 - 95 g (3.0 - 3.35 oz)**

6. Install slide joint assembly.
7. Install boot securely into grooves (indicated by \* marks) shown in the figure.

### CAUTION:

If there is grease on boot mounting surfaces (indicated by\* marks) of shaft and housing, boot may come off. Remove all grease from surfaces.

8. Make sure boot installation length "L" is the length indicated below. Insert a flat-bladed screwdriver or similar tool into smaller side of boot. Bleed air from boot to prevent boot deformation.

**Boot installation length "L" : 79.6 mm (3.13 in)**

### CAUTION:

- Boot may break if boot installation length is less than standard value.
- Take care not to touch the tip of screwdriver to inside of boot.

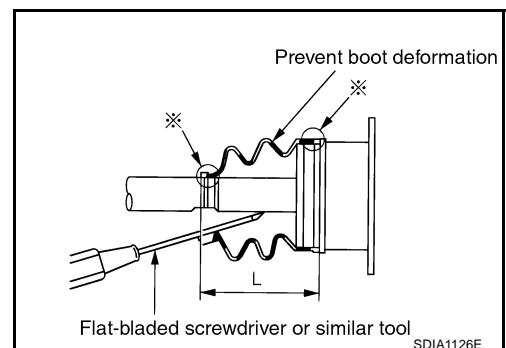

## REAR DRIVE SHAFT

- Secure big and small ends of boot with new boot bands as shown in the figure.

**CAUTION:**

**Discard old boot bands; replace with new ones.**

- After installing housing and shaft, rotate boot to check whether or not the actual position is correct. If boot position is not correct, secure boot with new boot band again.

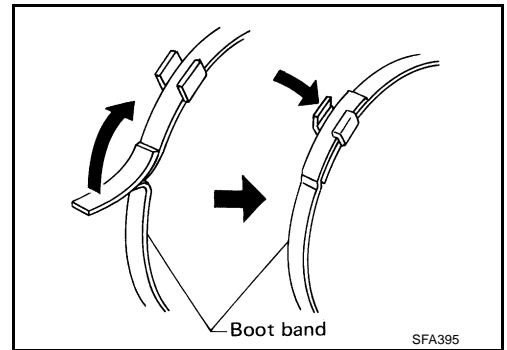

A  
B  
C

RAX

### Wheel Side

- Insert the amount of new grease (NISSAN genuine grease or equivalent) into joint sub-assembly serration hole until grease begins to ooze from ball groove and serration hole. After inserting grease, use a shop cloth to wipe off old grease that has oozed out.

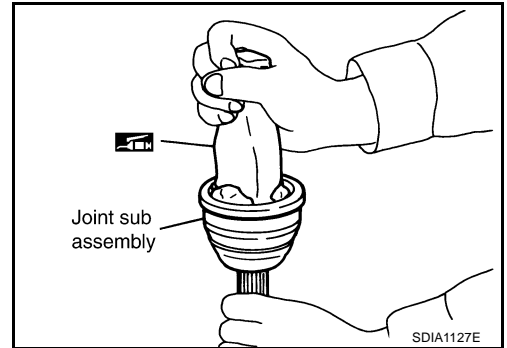

E  
F  
G

- Wind serrated part of shaft with tape. Install new boot band and boot to shaft. Be careful not to damage boot.

**CAUTION:**

**Discard old boot band and boot; replace with new ones.**

- Remove protective tape wound around serrated part of shaft.

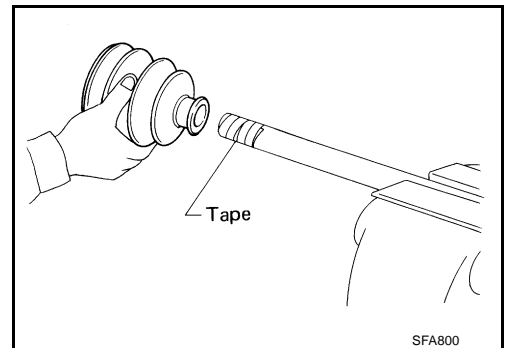

H  
I  
J

- Install new circular clip to shaft. At this time, circular clip must fit securely into shaft groove. Attach nut to joint sub-assembly. Use a wooden hammer to press-fit.

**CAUTION:**

**Discard old circular clip; replace with new one.**

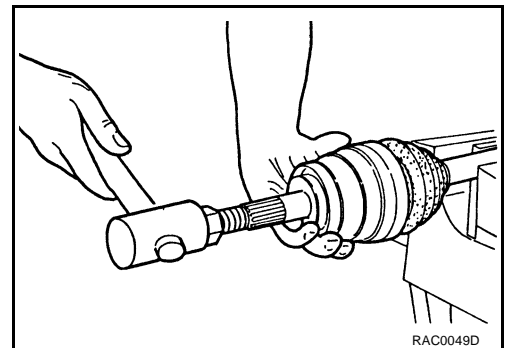

L  
M

- Insert the amount of new grease (NISSAN genuine grease or equivalent) listed below into housing from large end of boot.

**Grease amount : 75 - 85 g (2.65 - 3.0 oz)**

## REAR DRIVE SHAFT

6. Install boot securely into grooves (indicated by \* marks) shown in the figure.

**CAUTION:**

**If there is grease on boot mounting surfaces (indicated by\* marks) of shaft and housing, boot may come off. Remove all grease from surfaces.**

7. Make sure boot installation length "L" is the length indicated below. Insert a flat-bladed screwdriver or similar tool into smaller side of boot. Bleed air from boot to prevent boot deformation.

**Boot installation length "L" : 67.7mm (2.67 in)**

**CAUTION:**

- **Boot may break if boot installation length is less than standard value.**
- **Be careful that screwdriver tip does not contact inside surface of boot.**

8. Secure big and small ends of boot with new boot bands as shown in the figure.

**CAUTION:**

**Discard old boot bands; replace with new ones.**

9. Check installation status of boot. Rotate joint to make sure boot is securely in place. If not, reinstall using a new boot band.

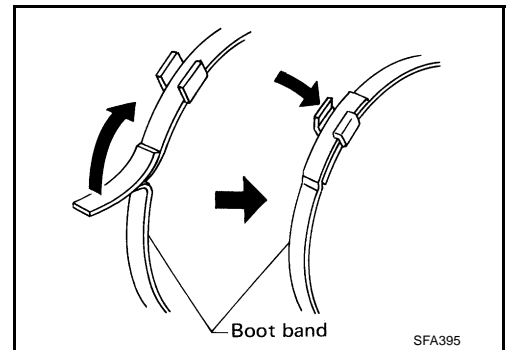
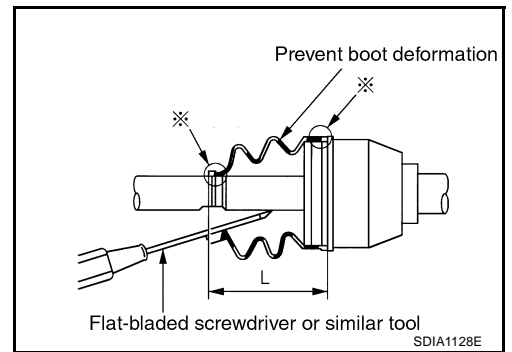

# SERVICE DATA AND SPECIFICATIONS (SDS)

## SERVICE DATA AND SPECIFICATIONS (SDS)

PFP:00030

### Wheel Bearing

ADS000JK

A

B

C

Axial end play limit	0.05 mm (0.002 in) or less
----------------------	----------------------------

### Drive Shaft

ADS000JL

RAX

E

F

G

H

I

J

K

L

M

Joint	Wheel side	Final drive side
Grease quantity	75 - 85g (2.65 - 3.0 oz)	85 - 95 g (3.0 - 3.35 oz)
Boots installed length	67.7 mm (2.67 in)	79.6 mm (3.13 in)

# SERVICE DATA AND SPECIFICATIONS (SDS)

---