

SECTION **FSU**
FRONT SUSPENSION

A
B
C
D
E
F
G
H
I
J
K
L
M
N
O
P

FSU

CONTENTS

SERVICE INFORMATION	2	COIL SPRING AND SHOCK ABSORBER	9
PRECAUTIONS	2	Removal and Installation	9
Precaution for Supplemental Restraint System (SRS) "AIR BAG" and "SEAT BELT PRE-TEN- SIONER"	2	Disassembly and Assembly	9
Precaution	2	STABILIZER BAR	12
PREPARATION	3	Removal and Installation	12
Special Service Tool	3	Inspection	13
Commercial Service Tool	3	TRANSVERSE LINK	14
NOISE, VIBRATION, AND HARSHNESS (NVH) TROUBLESHOOTING	4	Removal and Installation	14
NVH Troubleshooting Chart	4	FRONT SUSPENSION MEMBER	16
FRONT SUSPENSION ASSEMBLY	5	Removal and Installation	16
Component	5	SERVICE DATA AND SPECIFICATIONS (SDS)	19
On-vehicle Service	5	General Specification	19
Front Wheel Alignment	6	Front Wheel Alignment (Unladen*1)	19
		Lower Ball Joint	20
		Wheelarch Height (Unladen*)	20

PRECAUTIONS

< SERVICE INFORMATION >

SERVICE INFORMATION

PRECAUTIONS

Precaution for Supplemental Restraint System (SRS) "AIR BAG" and "SEAT BELT PRE-TENSIONER"

INFOID:000000001720267

The Supplemental Restraint System such as "AIR BAG" and "SEAT BELT PRE-TENSIONER", used along with a front seat belt, helps to reduce the risk or severity of injury to the driver and front passenger for certain types of collision. This system includes seat belt switch inputs and dual stage front air bag modules. The SRS system uses the seat belt switches to determine the front air bag deployment, and may only deploy one front air bag, depending on the severity of a collision and whether the front occupants are belted or unbelted. Information necessary to service the system safely is included in the SRS and SB section of this Service Manual.

WARNING:

- To avoid rendering the SRS inoperative, which could increase the risk of personal injury or death in the event of a collision which would result in air bag inflation, all maintenance must be performed by an authorized NISSAN/INFINITI dealer.
- Improper maintenance, including incorrect removal and installation of the SRS, can lead to personal injury caused by unintentional activation of the system. For removal of Spiral Cable and Air Bag Module, see the SRS section.
- Do not use electrical test equipment on any circuit related to the SRS unless instructed to in this Service Manual. SRS wiring harnesses can be identified by yellow and/or orange harnesses or harness connectors.

Precaution

INFOID:000000001720268

- When installing rubber parts, final tightening must be carried out under unladen condition* with tires on ground.
Oil will shorten the life of rubber bushings. Be sure to wipe off any spilled oil.
*: Fuel, engine coolant and engine oil full. Spare tire, jack, hand tools and mats in designated positions.
- After installing removed suspension parts, check wheel alignment and adjust if necessary.
- Lock nuts are un reusable parts; always use new ones.
When replacing, do not wipe the oil off the new lock nut before tightening.

PREPARATION

< SERVICE INFORMATION >

PREPARATION

Special Service Tool

INFOID:000000001720269

The actual shapes of Kent-Moore tools may differ from those of special service tools illustrated here.

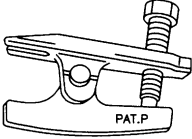
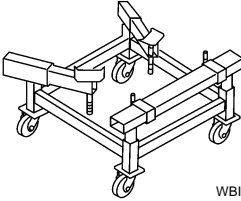
Tool number (Kent-Moore No.) Tool name	Description
HT72520000 (J-25730-A) Ball joint remover  NT146	Removing tie-rod outer end and lower ball joint
KV101J0010 (J-47242) Engine support table  WBIA0658E	Front suspension member removal

A

B

C

D

FSU

F

G

Commercial Service Tool

INFOID:000000001720270

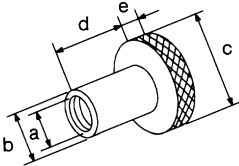
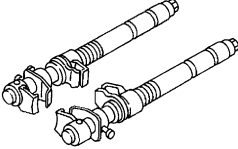
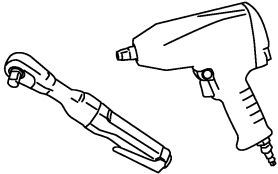
Tool name	Description
Attachment wheel alignment  NT148	Measure wheel alignment a: Screw M24 x 1.5 pitch b: 35 mm (1.38 in) dia. c: 65 mm (2.56 in) dia. d: 56 mm (2.20 in) e: 12 mm (0.47 in)
Spring compressor  NT717	Removing and installing coil spring
Power tool  PBIC0190E	Loosening bolts and nuts

H

I

J

K

L

M

N

O

P

NOISE, VIBRATION, AND HARSHNESS (NVH) TROUBLESHOOTING

< SERVICE INFORMATION >

NOISE, VIBRATION, AND HARSHNESS (NVH) TROUBLESHOOTING

NVH Troubleshooting Chart

INFOID:000000001720271

Use the following chart to help you find the cause of the symptom. If necessary, repair or replace these parts.

Reference page		FSU-5	FSU-9	FSU-5	—	FSU-9	FSU-5	FSU-6	FSU-12	FAX-4, "NVH Troubleshooting Chart"	FAX-4, "NVH Troubleshooting Chart"	WT-4, "NVH Troubleshooting Chart"	WT-4, "NVH Troubleshooting Chart"	BR-4, "NVH Troubleshooting Chart"	PS-5, "NVH Troubleshooting Chart"
Possible Cause and SUSPECTED PARTS		Improper installation, looseness	Shock absorber deformation, damage or deflection	Bushing or mounting deterioration	Parts interference	Spring fatigue	Suspension looseness	Incorrect wheel alignment	Stabilizer bar fatigue	DRIVE SHAFT	AXLE	TIRES	ROAD WHEEL	BRAKES	STEERING
Symptom	Noise	x	x	x	x	x	x			x	x	x	x	x	x
	Shake	x	x	x	x		x			x	x	x	x	x	x
	Vibration	x	x	x	x	x				x	x	x			x
	Shimmy	x	x	x	x			x			x	x	x	x	x
	Shudder	x	x	x							x	x	x	x	x
	Poor quality ride or handling	x	x	x	x	x		x	x		x	x	x		

x: Applicable

FRONT SUSPENSION ASSEMBLY

< SERVICE INFORMATION >

FRONT SUSPENSION ASSEMBLY

Component

INFOID:000000001720272

SEC. 391 • 400 • 401 • 406 • 540

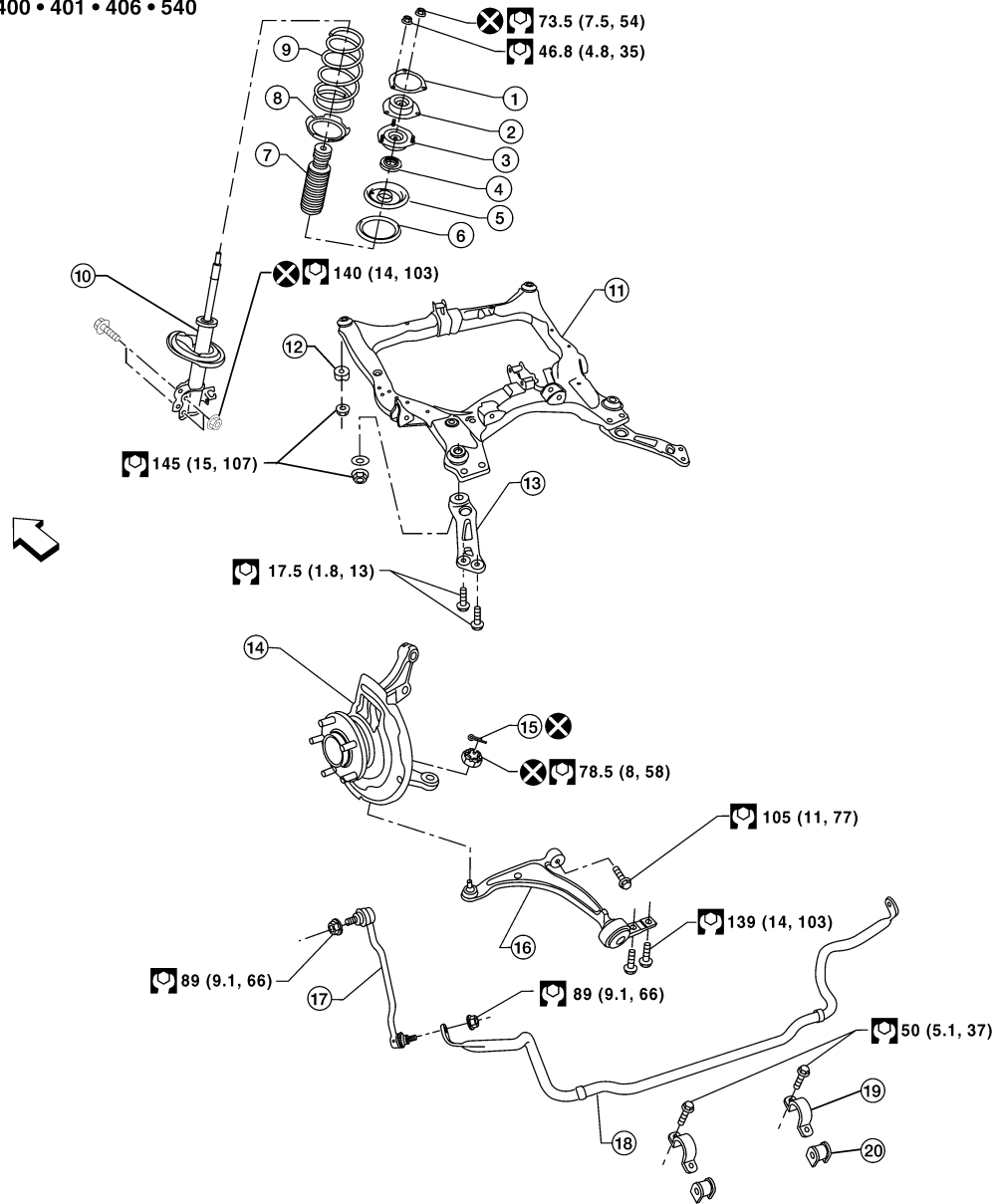

A

B

C

D

FSU

F

G

H

I

J

K

L

M

N

O

P

- | | | |
|----------------------------|---|-------------------------------|
| 1. Strut spacer | 2. Strut mount insulator | 3. Mounting insulator bracket |
| 4. Thrust bearing | 5. Upper spring seat | 6. Upper rubber seat |
| 7. Dust cover | 8. Lower rubber seat | 9. Coil spring |
| 10. Shock absorber (strut) | 11. Front suspension member | 12. Cup |
| 13. Member pin stay | 14. Wheel hub and steering knuckle assembly | 15. Cotter pin |
| 16. Transverse link | 17. Connecting rod | 18. Stabilizer bar |
| 19. Stabilizer clamp | 20. Stabilizer bushing | ← Front |

WEIA0157E

On-vehicle Service

INFOID:000000001720273

FRONT SUSPENSION PARTS

Check the front axle and front suspension parts for any excessive play, cracks, wear, or other damage.

FRONT SUSPENSION ASSEMBLY

< SERVICE INFORMATION >

- Raise the vehicle on a hoist and shake each front wheel to check for excessive play.
- Make sure that the cotter pin is inserted in the lower ball joint.
- Retighten all of the axle and suspension nuts and bolts to specification.

Tightening torques : Refer to [FSU-5, "Component"](#).

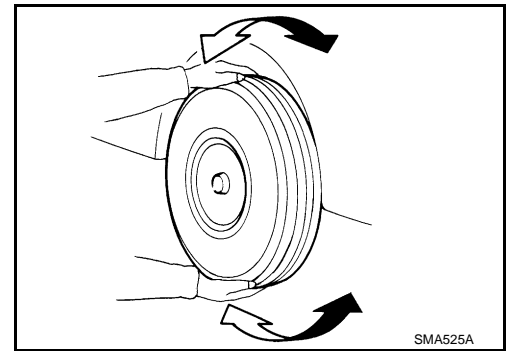

- Check the strut (shock absorber) for any oil leakage or other damage.
- Check the suspension ball joint for grease leakage and the ball joint dust cover for any cracks or other damage. If the ball joint dust cover is cracked or damaged, replace the transverse link.

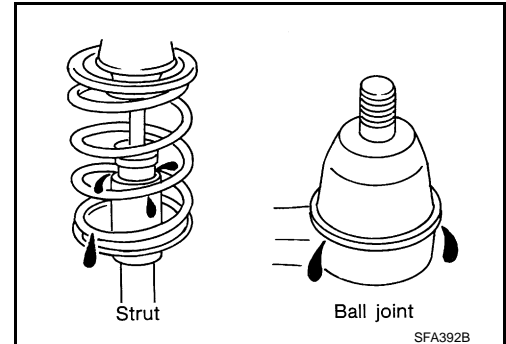

- Check the spring height "Hf" and "Hr" from the top of the wheelarch to the ground.
 - For proper measurement of the vehicle height, the vehicle must be unladen*, parked on a level surface, and tires checked for proper inflation and wear (the tread wear indicators must not be showing).
*: Fuel, radiator coolant and engine oil full. Spare tire, jack, hand tools and mats in designated positions.
 - Bounce the vehicle up and down several times before measuring the height.

Standard height : Refer to [FSU-20, "Wheelarch Height \(Unladen*\)"](#).

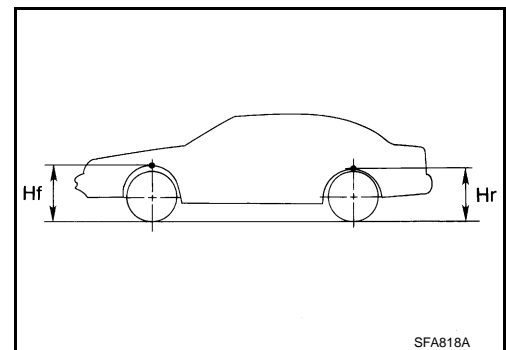

- The spring height is not adjustable. If the height is out of specification, check for worn springs or suspension parts.

Front Wheel Alignment

INFOID:000000001720274

DESCRIPTION

NOTE:

Before checking the front wheel alignment, be sure to make a preliminary inspection (Unladen*).

*: Fuel, radiator coolant and engine oil full. Spare tire, jack, hand tools and mats in designated positions.

PRELIMINARY INSPECTION

- Check the tires for wear and improper inflation.
- Check the wheel runout.

Wheel runout : Refer to [WT-5, "Inspection"](#).

- Check the front wheel bearings for looseness.
- Check the front suspension for looseness.
- Check the steering linkage for looseness.
- Check that the front shock absorbers work properly.
- Check the vehicle height (posture) in the unladen condition. Refer to [FSU-5, "On-vehicle Service"](#).

GENERAL INFORMATION AND RECOMMENDATIONS

1. A Four-Wheel Thrust Alignment should be performed.

FRONT SUSPENSION ASSEMBLY

< SERVICE INFORMATION >

- This type of alignment is recommended for any NISSAN vehicle.
 - The four-wheel “thrust” process helps ensure that the vehicle is properly aligned and the steering wheel is centered.
 - The alignment machine itself should be capable of accepting any NISSAN vehicle.
 - The alignment machine should be checked to ensure that it is level.
2. Make sure the alignment machine is properly calibrated.
 - Your alignment machine should be regularly calibrated in order to give correct information.
 - Check with the manufacturer of your specific alignment machine for their recommended Service/Calibration Schedule.

THE ALIGNMENT PROCESS

IMPORTANT: Use only the alignment specifications listed in this Service Manual. Refer to [FSU-19, "Front Wheel Alignment \(Unladen*1\)"](#).

1. When displaying the alignment settings, many alignment machines use “indicators”: (Green/red, plus or minus, Go/No Go). **Do NOT use these indicators.**
 - The alignment specifications programmed into your alignment machine that operate these indicators may not be correct.
 - This may result in an ERROR.
2. Some newer alignment machines are equipped with an optional “Rolling Compensation” method to “compensate” the sensors (alignment targets or head units). **Do NOT use this “Rolling Compensation” method.**
 - Use the “Jacking Compensation” method. After installing the alignment targets or head units, raise the vehicle and rotate the wheels 1/2 turn both ways.
 - See Instructions in the alignment machine you are using for more information.

CAMBER, CASTER AND KINGPIN INCLINATION

NOTE:

Camber, caster and kingpin inclination are preset at factory and cannot be adjusted.

1. Measure the camber, caster and kingpin inclination of both the right and left wheels using attachment Tool and a suitable alignment gauge.

Camber, caster and kingpin inclination : Refer to [FSU-19, "Front Wheel Alignment \(Unladen*1\)"](#).

2. If the camber, caster or kingpin inclination is not within specification, inspect the front suspension parts. Replace any damaged or worn out parts.

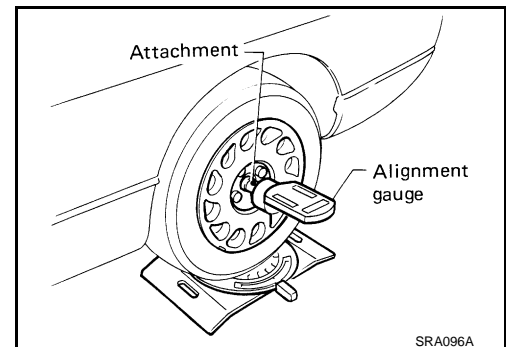

TOE-IN

WARNING:

- Always perform the following procedure on a flat surface.
 - Make sure that no person is in front of the vehicle before pushing it.
1. Bounce the front of vehicle up and down to stabilize the vehicle height (posture).
 2. Push the vehicle straight ahead about 5 m (16 ft).
 3. Put a mark on base line of the tread (rear side) of both front tires at the same height as hub center as shown. These marks are measuring points.

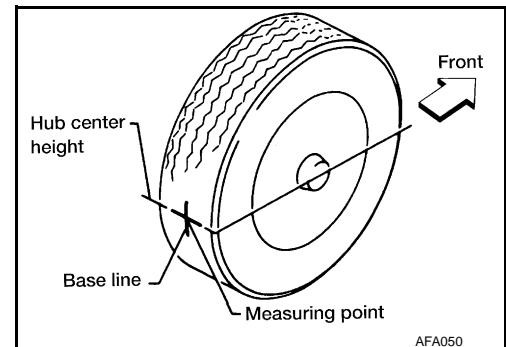

FRONT SUSPENSION ASSEMBLY

< SERVICE INFORMATION >

4. Measure the distance "A" on the rear side of the front tires as shown.
5. Push the vehicle slowly ahead to rotate the wheels 180° degrees (1/2 a turn).

CAUTION:

If the wheels have rotated more than 180° degrees (1/2 turn), start this procedure again from the beginning. Never push the vehicle backward.

6. Measure the distance "B" on the front side of the front tires at the same marks as shown.

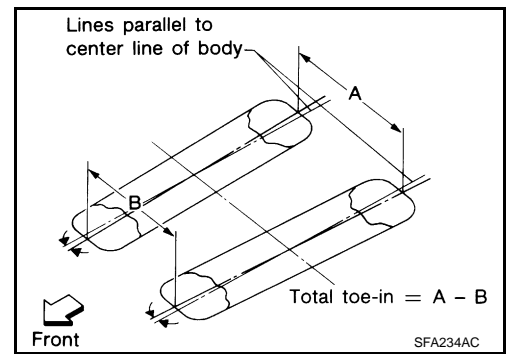

Total toe-in : Refer to [FSU-19, "Front Wheel Alignment \(Unladen*1\)"](#).

7. Adjust the toe-in by varying the length of the steering outer tie-rods.
 - a. Loosen the outer tie-rod lock nuts.
 - b. Adjust the toe-in by screwing the outer tie-rods in or out.

Standard length "L" : Refer to [PS-30, "Steering Gear and Linkage"](#).

- c. Tighten the outer tie-rod lock nuts to specified torque.

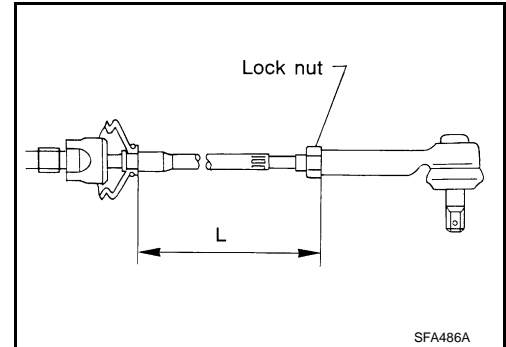

Lock nut : Refer to [PS-19, "Removal and Installation"](#).

FRONT WHEEL TURNING ANGLE

1. Set the front wheels in a straight-ahead position. Then move the vehicle forward until the front wheels rest on the turning radius gauge as shown.
2. Rotate steering wheel all the way right and left; measure the turning angles "A" and "B" as shown.

Wheel turning angle (full turn) : Refer to [FSU-19, "Front Wheel Alignment \(Unladen*1\)"](#).

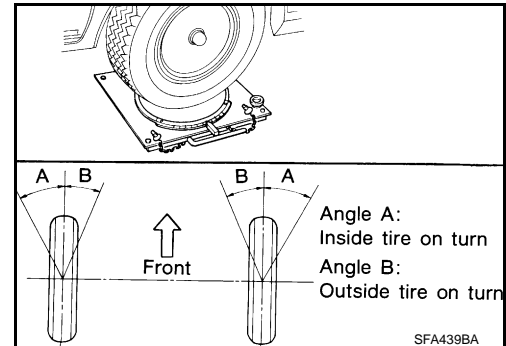

COIL SPRING AND SHOCK ABSORBER

< SERVICE INFORMATION >

COIL SPRING AND SHOCK ABSORBER

Removal and Installation

INFOID:000000001720275

REMOVAL

1. Remove wheel and tire using power tool.
2. Disconnect the wheel sensor wire and front brake hose from the brackets on the shock absorber (strut).
3. Disconnect the connecting rod upper link using power tool.
4. Support the wheel hub and steering knuckle assembly with a suitable wire.
5. Remove the shock absorber (strut) lower bolts and nuts using power tool.

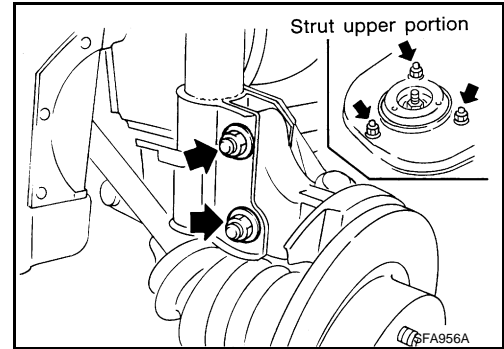

6. Remove hoodledge covers.
7. Remove the three upper shock absorber (strut) mounting nuts using power tool.
CAUTION:
Do not remove piston rod lock nut on vehicle.
8. Remove the shock absorber (strut) assembly.

INSTALLATION

Installation is in the reverse order of removal.

- After installation, check that the front wheel alignment is within specification. Refer to [FSU-6, "Front Wheel Alignment"](#).
- When installing the strut spacer, it must be positioned as shown.

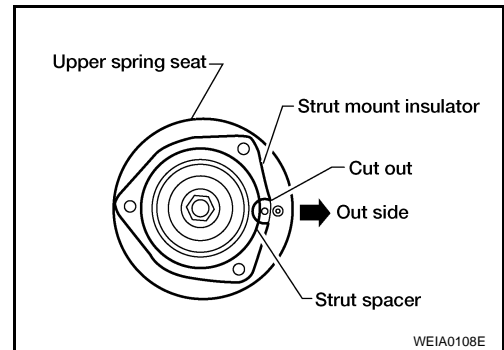

- Tighten all nuts and bolts to specification. Refer to [FSU-5, "Component"](#).

WARNING:

- **Always replace the shock absorber (strut) lower mounting nuts.**
- **When installing shock absorber (strut) to steering knuckle, be sure to hold bolts when tightening nuts.**
- Install wheel and tire. Refer to [WT-7, "Tire Rotation"](#).

Disassembly and Assembly

INFOID:000000001720276

DISASSEMBLY

COIL SPRING AND SHOCK ABSORBER

< SERVICE INFORMATION >

1. Set the shock absorber (strut) in a vise, then loosen (without removing) the piston rod lock nut as shown.

CAUTION:

Do not remove piston rod lock nut at this time.

2. Compress the spring using commercial service tool so that the shock absorber mounting insulator can be turned by hand.

WARNING:

Make sure that the pawls of the two spring compressors are firmly hooked on the spring. The spring compressors must be tightened alternately and evenly so as not to tilt the spring.

3. Remove the shock absorber (strut) rod lock nut.

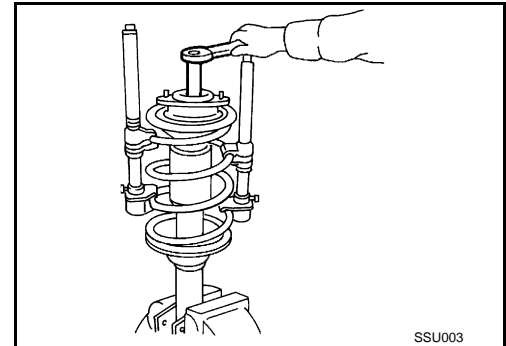
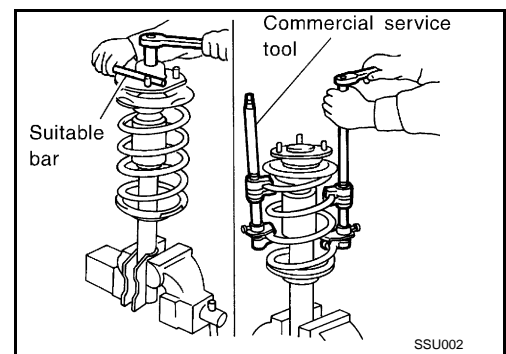

INSPECTION AFTER DISASSEMBLY

SHOCK ABSORBER (STRUT) ASSEMBLY

- Check for smooth operation through a full stroke, both compression and extension.
- Check for oil leakage on welded or gland packing portions.
- Check shock absorber (strut) rod for cracks, deformation or other damage and replace if necessary.

MOUNTING INSULATOR AND RUBBER PARTS

Check cemented rubber-to-metal portion for separation or cracks. Check rubber parts for deterioration and replace if necessary.

THRUST BEARING

Check the thrust bearing for abnormal noise or excessive rattle in axial direction and replace if necessary.

COIL SPRING

- Check for cracks, deformation or other damage and replace if necessary.
- Check spring free height. Refer to [FSU-19. "General Specification"](#).

1. When installing coil spring on shock absorber (strut), it must be positioned as shown.

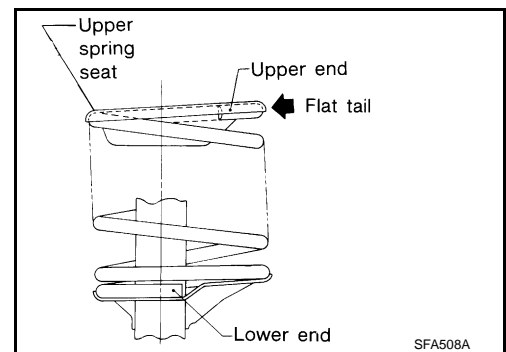

COIL SPRING AND SHOCK ABSORBER

< SERVICE INFORMATION >

2. Install upper spring seat with alignment mark facing the outer side of vehicle, in line with strut-to-knuckle attachment points.

NOTE:

LH side shown, RH side similar.

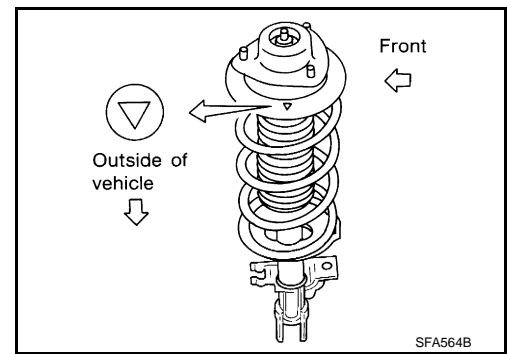

A
B
C
D

FSU

F
G
H
I
J
K
L
M
N
O
P

STABILIZER BAR

< SERVICE INFORMATION >

STABILIZER BAR

Removal and Installation

INFOID:000000001720277

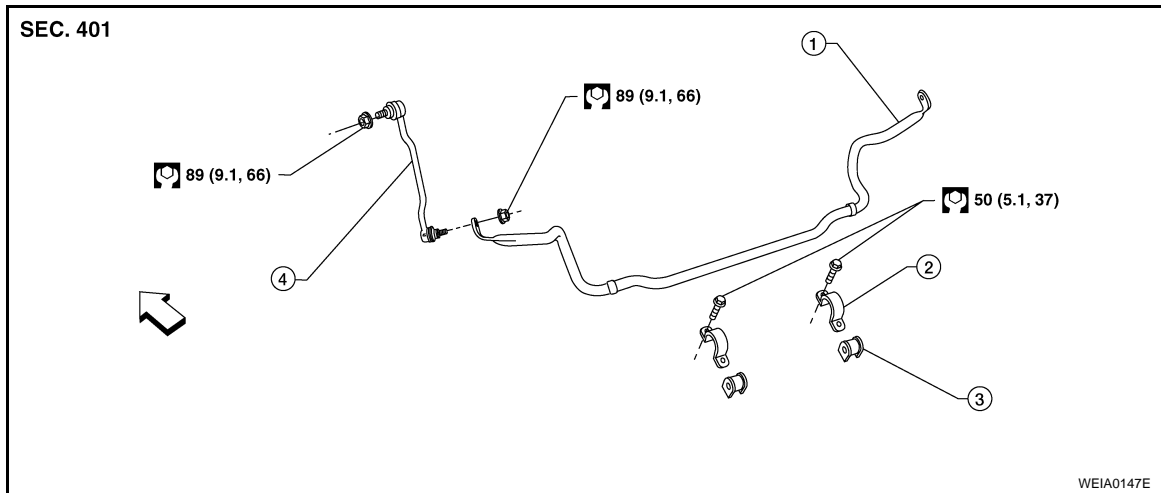

- | | | |
|-------------------|------------|------------|
| 1. Stabilizer bar | 2. Bracket | 3. Bushing |
| 4. Connecting rod | ← Front | |

REMOVAL

1. Remove the wheel and tire.
2. Remove front exhaust tube using power tool. Refer to [EX-4, "Removal and Installation"](#).
3. Disconnect the connecting rod end at the stabilizer bar using power tool.
 - Prevent the stabilizer connecting rod from turning by inserting a hex wrench into the end of the ball stud, then remove nut.
4. Remove the rear engine mount insulator using power tool. Refer to [FSU-16, "Removal and Installation"](#).
5. Remove the LH and RH member pin stays using power tool, then remove the rear suspension member mounting nuts. Refer to [FSU-16, "Removal and Installation"](#).
 - Support rear of suspension member, then lower rear of suspension member to gain access to stabilizer bar mounting brackets.
6. Remove the two stabilizer bar brackets from the front suspension member using power tool.
7. Remove the front stabilizer bar.
 - Remove the two stabilizer bar bushings as necessary.

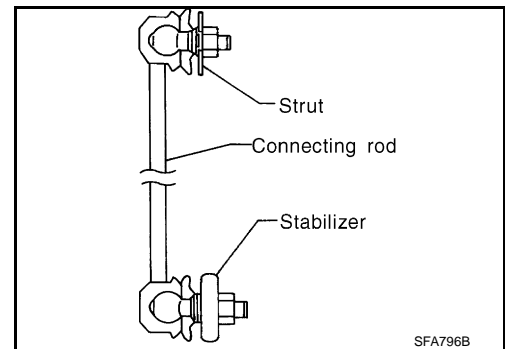

INSTALLATION

Installation is in the reverse order of removal.

- When installing stabilizer bar, make sure that the clamps are facing in the correct direction as shown.

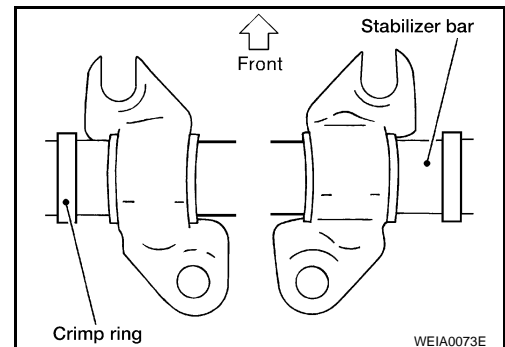

STABILIZER BAR

< SERVICE INFORMATION >

- Make sure that slit in bushing is in the position as shown.
- Lubricate the inner and outer surfaces of the bushing using a silicone lubricant.

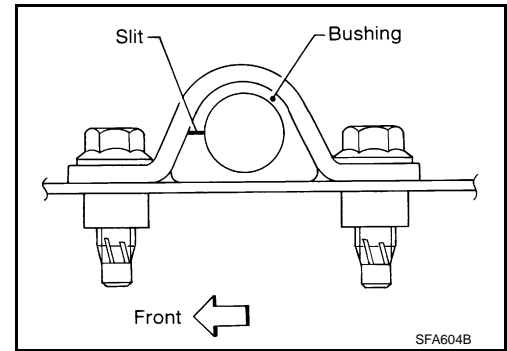

- Install stabilizer bar with ball joint socket properly placed as shown.
- When installing wheel and tire, refer to [WT-7. "Tire Rotation"](#).

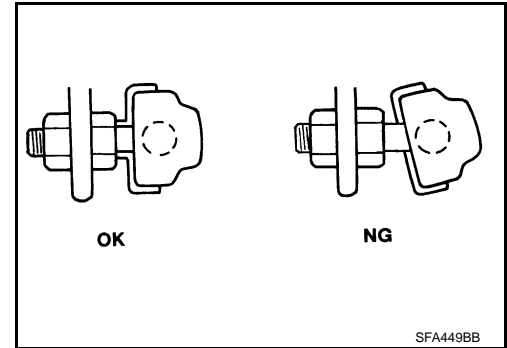

Inspection

- Check the stabilizer bar for deformation or cracks and replace if necessary.
- Check the bushings for deterioration or cracks. Replace if necessary.
- Check that the ball joint can rotate in all directions. If movement is not smooth and free, replace stabilizer bar connecting rod.

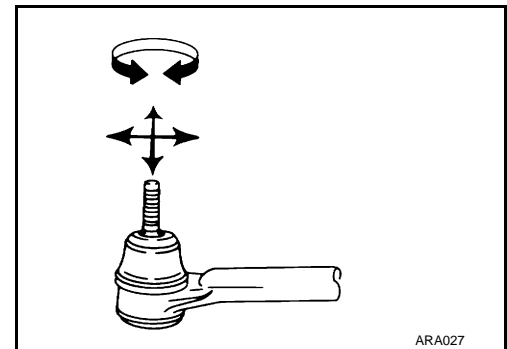

A
B
C
D
FSU
F
G
H
I
J
K
L
M
N
O
P

TRANSVERSE LINK

< SERVICE INFORMATION >

TRANSVERSE LINK

Removal and Installation

INFOID:000000001720279

REMOVAL

1. Remove the wheel and tire using power tool.
2. Remove the lower ball joint cotter pin and remove the lower ball joint nut using power tool.

CAUTION:

Discard the cotter pin and use a new cotter pin for installation.

3. Disconnect the lower ball joint from the steering knuckle using Tool as shown.

Tool number : HT72520000 (J-25730-A)

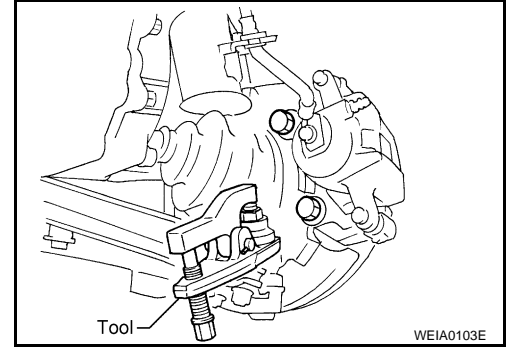

4. Remove the member stay pin nut and two bolts using power tool, and remove the member stay pin.
5. Remove the two transverse link pivot bolts using power tool.
6. Remove the transverse link bolt and remove the transverse link from the front suspension member.

INSPECTION AFTER REMOVAL

Visual Check

- Check the transverse link for damage, cracks or deformation. Replace it if necessary.
- Check the bushing for damage, cracks and deformation. Replace the transverse link if necessary.

Lower Ball Joint

- Check the ball joint for excessive play. Replace the transverse link assembly if any of the following exists:
 - Lower ball joint stud is worn.
 - Lower ball joint is hard to swing.
 - Lower ball joint play in axial directions or end play is excessive.

Swinging Force

NOTE:

Before checking the axial forces and end play, turn the lower ball joint at least 10 revolutions so that the ball joint is properly broken in.

Swinging force "A" (measuring from cotter pin hole of ball stud) : 7.8 - 54.9 N (0.8 - 5.6 kg-f, 1.8 - 12.3 lb-f)

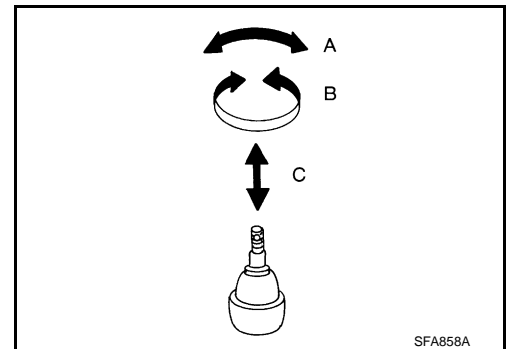

Turning Force

NOTE:

Before checking the axial forces and end play, turn the lower ball joint at least 10 revolutions so that the ball joint is properly broken in.

TRANSVERSE LINK

< SERVICE INFORMATION >

Turning torque "B" : 0.49 - 3.43 N·m (5.0 - 35.0 kg·cm,
4.3 - 30.4 in·lb)

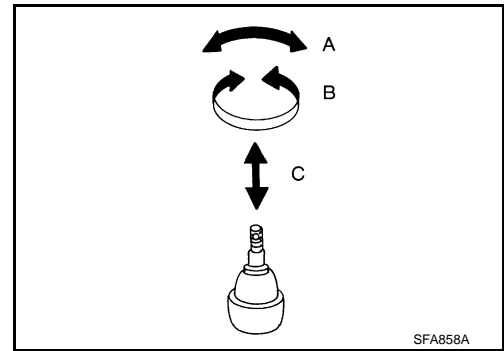

Vertical End Play

Check dust cover for damage. Replace it and the cover clamp if necessary.

NOTE:

Before checking the axial forces and end play, turn the lower ball joint at least 10 revolutions so that the ball joint is properly broken in.

Vertical end play "C" : 0 mm (0 in)

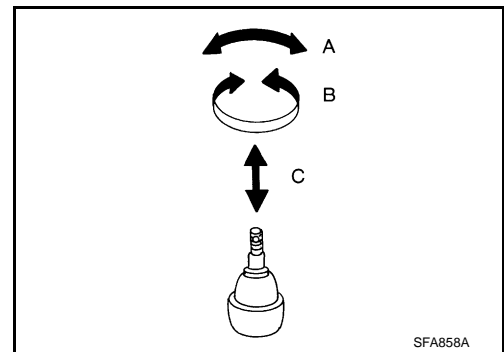

INSTALLATION

Installation is in the reverse order of removal.

- Tighten the transverse link mounting bolts to specified torque. Refer to [FSU-5, "Component"](#). During installation, the final tightening must be done with the vehicle in unladen* condition and the tires on the ground.
*: Fuel, engine coolant and engine oil full. Spare tire, jack, hand tools and mats in designated positions.

CAUTION:

Discard the old cotter pin and use a new cotter pin for installation of the lower ball joint nut.

- Install wheel and tire. Refer to [WT-7, "Tire Rotation"](#).
- After installation, check the wheel alignment. Refer to [FSU-6, "Front Wheel Alignment"](#).

FRONT SUSPENSION MEMBER

< SERVICE INFORMATION >

FRONT SUSPENSION MEMBER

Removal and Installation

INFOID:000000001720280

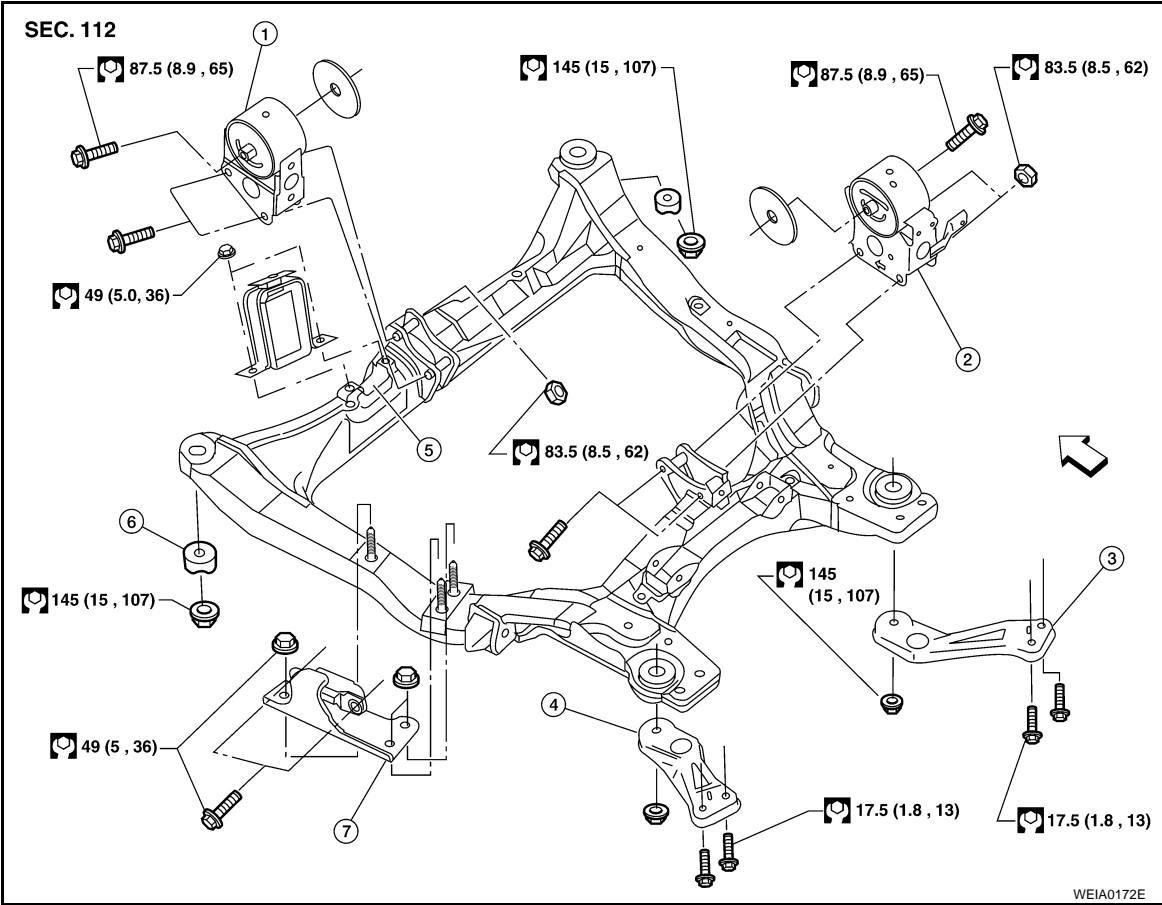

- | | | |
|------------------------------------|-----------------------------------|------------------------|
| 1. Front engine mounting insulator | 2. Rear engine mounting insulator | 3. Member pin stay, RH |
| 4. Member pin stay, LH | 5. Front suspension member | 6. Cup |
| 7. LH transaxle mounting insulator | ⇐: Front | |

REMOVAL

1. Install the engine slingers into the front of the left cylinder head, and the right rear cylinder head as shown.

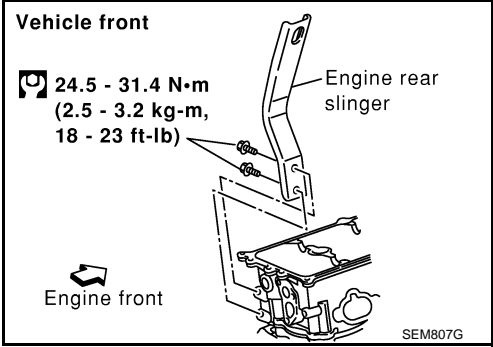

FRONT SUSPENSION MEMBER

< SERVICE INFORMATION >

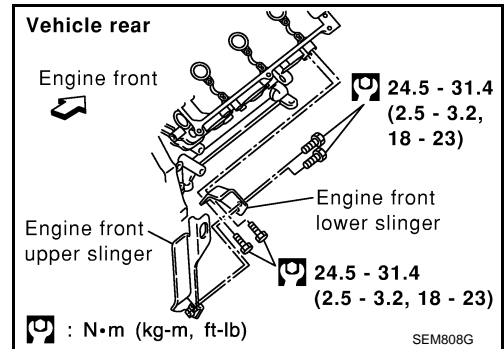

2. Support the engine from the front and rear slingers using a suitable tool.
3. Remove the engine under cover.
4. Remove the front wheels and tires using power tool.
5. Remove the splash shields.
6. Remove the two bolts from the LH transaxle mounting insulator (1) as shown.

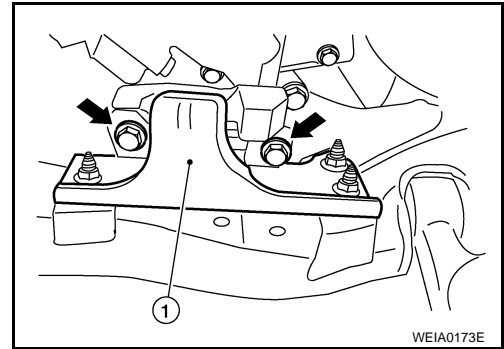

7. Remove the lower ball joint cotter pin and remove the lower ball joint nut using power tool.

CAUTION:

Discard the cotter pin and use a new cotter pin for installation.

8. Disconnect the lower ball joint from the steering knuckle using Tool as shown.

Tool number : HT2520000 (J-25730-A)

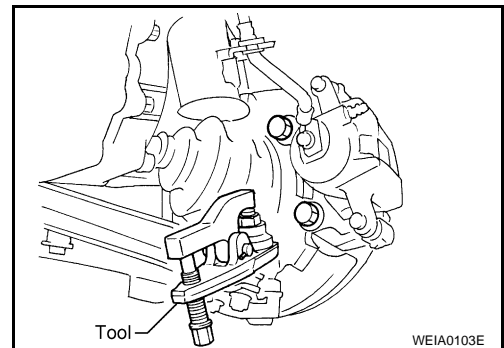

9. Remove the front exhaust tube using power tool. Refer to [EX-4, "Removal and Installation"](#).
10. Remove the power steering line bracket from the front suspension member.
11. Remove the steering gear to suspension member bolts.
12. Disconnect the front and rear engine mount electrical connectors, if equipped.

13. Disconnect the connecting rod from the front strut using power tool.
 - Prevent the stabilizer connecting rod from turning by inserting a hex wrench into the end of the ball stud, then remove nut.
14. Set Tool under the front suspension member for support, then remove the nuts from the front suspension member using power tool.

Tool number : KV101J0010 (J-47242)

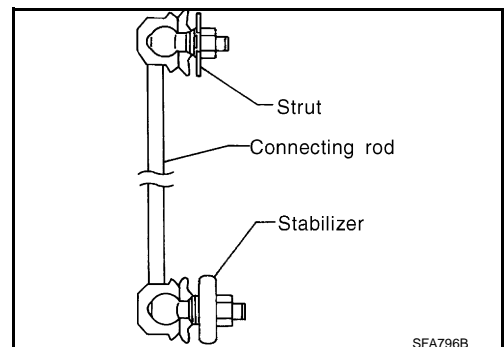

A
B
C
D
FSU
F
G
H
I
J
K
L
M
N
O
P

FRONT SUSPENSION MEMBER

< SERVICE INFORMATION >

15. Remove the bolts from the front suspension member pin stay on the vehicle body side using power tool.
16. Remove the through bolts from the front and rear engine mounting insulators.
17. Lower the suspension member slowly.
 - If necessary, remove the exhaust hanger bracket from the front suspension member.
 - If necessary, remove the front and rear engine mounting insulators.
 - If necessary, remove the transverse link.

INSTALLATION

Installation is in the reverse order of removal.

- Tighten the two LH transaxle mounting insulator bolts to specification.
- Tighten the stabilizer bar and connecting rod nuts and bolts to specification. Refer to [FSU-5, "Component"](#).

CAUTION:

Tighten the suspension nuts and bolts with the vehicle on the ground.

- Install the stabilizer bar bushings and brackets in the specified orientation. Refer to [FSU-12, "Removal and Installation"](#).
- Tighten the steering gear bolts to specification. Refer to [PS-19, "Removal and Installation"](#).
- Install wheel and tire. Refer to [WT-7, "Tire Rotation"](#).
- Check the wheel alignment. Refer to [FSU-6, "Front Wheel Alignment"](#).

SERVICE DATA AND SPECIFICATIONS (SDS)

< SERVICE INFORMATION >

SERVICE DATA AND SPECIFICATIONS (SDS)

General Specification

INFOID:000000001720281

Unit: mm (in)

Model grade	SE	SL
Suspension type	Independent MacPherson strut	
Shock absorber type	Double-acting hydraulic	
Stabilizer bar	Standard equipment	
Spring free height	360 (14.17)	370 (14.57)

Front Wheel Alignment (Unladen*1)

INFOID:000000001720282

Market		United States and Canada		Mexico
Tire size		225/55R17	245/45R18	All
Camber degree minute (decimal degree)	Minimum	-1°00' (-1.00°)		-0°50' (-0.83°)
	Nominal	-0°15' (-0.25°)		-0°05' (-0.08°)
	Maximum	0°30' (0.50°)		0°40' (0.67°)
	Left and right difference	45' (0.75°) or less		45' (0.75°) or less
Caster degree minute (decimal degree)	Minimum	2°05' (2.08°)		1°55' (1.92°)
	Nominal	2°50' (2.83°)		2°40' (2.67°)
	Maximum	3°35' (3.58°)		3°25' (3.42°)
	Left and right difference	45' (0.75°) or less		45' (0.75°) or less
Kingpin inclination degree minute (decimal degree)	Minimum	13°50' (13.83°)		13°10' (13.17°)
	Nominal	14°35' (14.58°)		13°55' (13.92°)
	Maximum	15°20' (15.33°)		14°40' (14.67°)

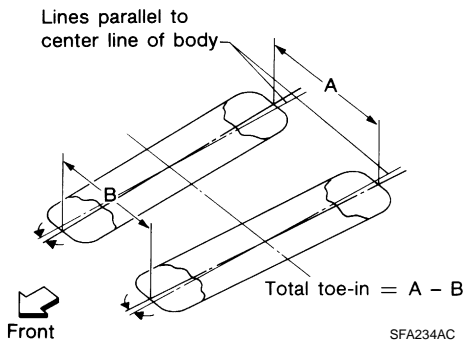

Total toe-in	Distance (A - B) mm (in)	Minimum	-0.5 (-0.020)	0.0 (0.000)
		Nominal	0.5 (0.020)	1.0 (0.040)
		Maximum	1.5 (0.059)	2.0 (0.080)
	Angle (left plus right) degree minute (decimal degree)	Minimum	—	—
		Nominal	0°2' (0.03°)	0°3' (0.05°)
		Maximum	—	—

SERVICE DATA AND SPECIFICATIONS (SDS)

< SERVICE INFORMATION >

Wheel turning angle full turn*2	Inside degree minute (decimal degree)	Minimum	32°00' (32.0°)	31°00' (31.0°)	—
		Nominal	35°30' (35.5°)	34°30' (34.5°)	—
		Maximum	36°30' (36.5°)	35°30' (35.5°)	—
	Outside degree minute (decimal degree)	Nominal	29°00' (29.0°)	28°30' (28.5°)	—

*1: Fuel, radiator coolant and engine oil full. Spare tire, jack, hand tools and mats in designated positions.

*2: On power steering models, wheel turning force (at circumference of steering wheel) of 98 to 147 N (10 to 15 kg, 22 to 33 lb) with engine idle.

Lower Ball Joint

INFOID:000000001720283

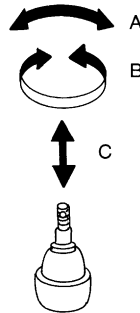

SFA858A

Swinging force "A" (Measuring point: cotter pin hole of ball stud) N (kg-f, lb-f)	7.8 - 54.9 (0.8 - 5.6, 1.8 - 12.3)
Turning torque "B" N·m (kg-cm, in-lb)	0.49 - 3.43 (5.0 - 35.0, 4.3 - 30.4)
Vertical end play "C" mm (in)	0 (0)

Wheelarch Height (Unladen*)

INFOID:000000001720284

Unit: mm (in)

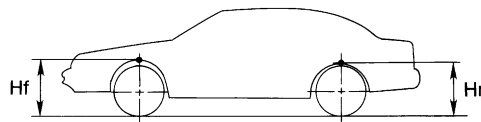

SFA818A

Market	United States and Canada		Mexico	
	Tire		Tire	
	225/55R17	245/45R18	225/55R17	245/45R18
Front (Hf)	738 (29.06)	737 (29.02)	787 (30.98)	761 (29.96)
Rear (Hr)	705 (27.76)	705 (27.76)	743 (29.25)	726 (28.58)

*: Fuel, radiator coolant and engine oil full. Spare tire, jack, hand tools and mats in designated positions.