

A

ACC

SECTION ACC

ACCELERATOR CONTROL SYSTEM

C

CONTENTS

D

E

<p>PRECAUTIONS 2</p> <p>Precautions for Supplemental Restraint System (SRS) "AIR BAG" and "SEAT BELT PRE-TENSIONER" 2</p>	<p>ACCELERATOR CONTROL SYSTEM 3</p> <p>Removal and Installation 3</p> <p>REMOVAL 3</p> <p>INSTALLATION 3</p> <p>SERVICE DATA AND SPECIFICATIONS (SDS) 4</p> <p>Accelerator Control 4</p> <p>PEDAL TRAVEL 4</p>	<p>F</p> <p>G</p> <p>H</p> <p>I</p> <p>J</p> <p>K</p> <p>L</p> <p>M</p>
--	--	---

PRECAUTIONS

PRECAUTIONS

PFP:00001

Precautions for Supplemental Restraint System (SRS) “AIR BAG” and “SEAT BELT PRE-TENSIONER”

EBS00RBM

The Supplemental Restraint System such as “AIR BAG” and “SEAT BELT PRE-TENSIONER”, used along with a front seat belt, helps to reduce the risk or severity of injury to the driver and front passenger for certain types of collision. This system includes seat belt switch inputs and dual stage front air bag modules. The SRS system uses the seat belt switches to determine the front air bag deployment, and may only deploy one front air bag, depending on the severity of a collision and whether the front occupants are belted or unbelted. Information necessary to service the system safely is included in the SRS and SB section of this Service Manual.

WARNING:

- To avoid rendering the SRS inoperative, which could increase the risk of personal injury or death in the event of a collision which would result in air bag inflation, all maintenance must be performed by an authorized NISSAN/INFINITI dealer.
- Improper maintenance, including incorrect removal and installation of the SRS, can lead to personal injury caused by unintentional activation of the system. For removal of Spiral Cable and Air Bag Module, see the SRS section.
- Do not use electrical test equipment on any circuit related to the SRS unless instructed to in this Service Manual. SRS wiring harnesses can be identified by yellow and/or orange harnesses or harness connectors.

ACCELERATOR CONTROL SYSTEM

PF:18005

EBS00JTF

ACCELERATOR CONTROL SYSTEM

Removal and Installation

REMOVAL

1. Disconnect the negative battery cable.
2. Disconnect the accelerator position sensor electrical connector.
 - a. Pull the connector lock back to unlock the connector from the accelerator pedal position sensor as shown.
 - b. Pull up on the connector to disconnect it from the accelerator pedal position sensor as shown.

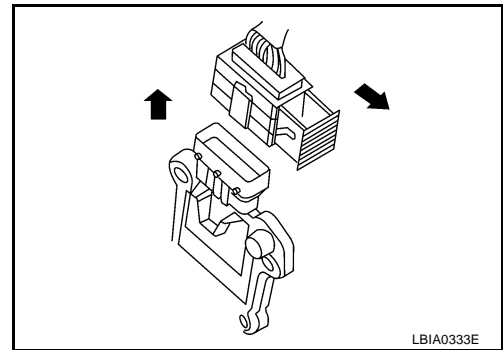

3. Remove the upper accelerator pedal nuts and lower accelerator pedal bolt.
4. Remove the accelerator pedal and accelerator position sensor assembly.
 - For electrical inspection of the accelerator pedal position sensor, refer to [EC-570, "ACCELERATOR PEDAL POSITION SENSOR"](#).

CAUTION:

- Do not disassemble the pedal assembly. Do not remove the accelerator pedal position sensor from the pedal assembly.
- Avoid impact from dropping during handling.
- Keep the pedal assembly away from water.

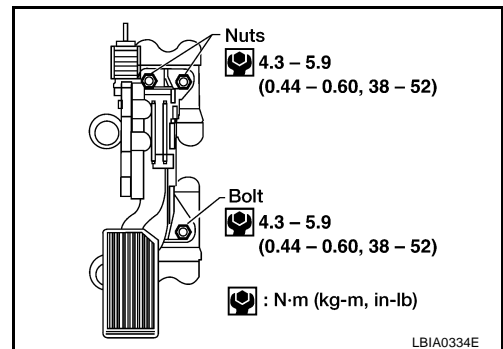

INSTALLATION

1. Installation is in the reverse order of removal.
 - Check the accelerator pedal for smooth operation. There should be no binding or sticking when applying or releasing the accelerator pedal.
 - Check that the accelerator pedal moves through the full specified distance of pedal travel.

Pedal travel A : 52.6 - 58.2 mm (2.07 - 2.29 in)

CAUTION:

When the harness connector of the accelerator pedal position sensor is disconnected, perform the "Accelerator pedal released position learning". Refer to [EC-79, "Accelerator Pedal Released Position Learning"](#).

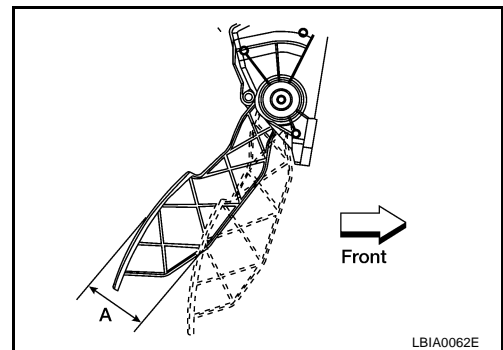

SERVICE DATA AND SPECIFICATIONS (SDS)

SERVICE DATA AND SPECIFICATIONS (SDS)

PFP:00030

Accelerator Control PEDAL TRAVEL

EBS00JTG

Accelerator control pedal - total travel	52.6 - 58.2 mm (2.07 - 2.29 in)
--	---------------------------------
