

BRAKE SYSTEM

SECTION BR

CONTENTS

PRECAUTIONS	4	OPERATING CHECK	20
Supplemental Restraint System (SRS) "AIR BAG" and "SEAT BELT PRE-TENSIONER"	4	AIRTIGHT CHECK	20
Precautions for Brake System	4	Removal	20
Wiring Diagrams and Trouble Diagnosis	5	Inspection	20
PREPARATION	6	OUTPUT ROD LENGTH CHECK	20
Commercial Service Tools	6	Installation	20
NOISE, VIBRATION AND HARSHNESS (NVH)		VACUUM HOSE	22
TROUBLESHOOTING	7	Removal and Installation	22
NVH Troubleshooting Chart	7	Inspection	22
ON-VEHICLE SERVICE	8	HOSES AND CONNECTORS	22
Checking Brake Fluid Level	8	CHECK VALVE	22
Checking Brake Line	8	FRONT DISC BRAKE	23
Changing Brake Fluid	8	Component	23
Brake Burnishing Procedure	8	Pad Replacement	23
Bleeding Brake System	9	Removal	24
BRAKE HYDRAULIC LINE	10	Disassembly	24
Hydraulic Circuit	10	Inspection	25
Removal	10	CALIPER	25
Inspection	11	ROTOR	25
Installation	11	Assembly	26
BRAKE PEDAL AND BRACKET	12	Installation	26
Removal and Installation	12	REAR DISC BRAKE	27
Inspection	12	Component	27
Adjustment	12	Pad Replacement	27
MASTER CYLINDER (TOKICO)	14	Removal	29
Removal	14	Disassembly	30
Disassembly	15	Inspection	31
Inspection	15	CALIPER	31
Assembly	15	ROTOR	31
Installation	16	Assembly	32
MASTER CYLINDER [BOSCH (NABCO)]	17	Installation	34
Removal	17	PARKING BRAKE CONTROL (CENTER LEVER TYPE)	35
Disassembly	18	Components	35
Inspection	18	Removal and Installation	35
Assembly	18	Inspection	35
Installation	19	Adjustment	36
BRAKE BOOSTER	20	PARKING BRAKE CONTROL (FOOT LEVER TYPE)	37
On-vehicle Service	20		

GI
MA
EM
LC
EC
FE
CL
MT
AT
AX
SU
BR
ST
RS
BT
HA
SC
EL
IDX

CONTENTS (Cont'd)

Components.....	37
Removal and Installation	37
Inspection.....	37
Adjustment.....	38

	ABS	
--	------------	--

DESCRIPTION	39
Purpose.....	39
ABS (Anti-Lock Brake System) Operation	39
ABS Hydraulic Circuit	39
System Components	40
System Description.....	40
SENSOR.....	40
CONTROL UNIT	40
ABS ACTUATOR AND ELECTRIC UNIT	41
Component Parts and Harness Connector	
Location	42
Schematic	43
Wiring Diagram - ABS -	44

ON BOARD DIAGNOSTIC SYSTEM

DESCRIPTION	48
CONSULT-II	48
CONSULT-II APPLICATION TO ABS.....	48
ECU (ABS CONTROL UNIT) PART NUMBER	
MODE	48
CONSULT-II Inspection Procedure.....	48
SELF-DIAGNOSIS PROCEDURE.....	48
SELF-DIAGNOSTIC RESULTS MODE (FOR M/T	
MODELS).....	50
DATA MONITOR PROCEDURE	51
SELF-DIAGNOSTIC RESULTS MODE (FOR A/T	
MODELS).....	52
DATA MONITOR PROCEDURE	52
ACTIVE TEST PROCEDURE	53
DATA MONITOR MODE.....	54
ACTIVE TEST MODE	55

TROUBLE DIAGNOSIS - INTRODUCTION.....56

How to Perform Trouble Diagnoses for Quick	
and Accurate Repair	56
INTRODUCTION.....	56

TROUBLE DIAGNOSIS - BASIC INSPECTION.....57

Preliminary Check.....	57
Ground Circuit Check	60
ABS ACTUATOR AND ELECTRIC UNIT GROUND.....	60

TROUBLE DIAGNOSES FOR SELF-DIAGNOSTIC

ITEMS	61
Wheel Sensor or Rotor.....	61
DIAGNOSTIC PROCEDURE.....	61
ABS Actuator Solenoid Valve or Solenoid Valve	
Relay.....	66
DIAGNOSTIC PROCEDURE.....	66
Motor Relay or Motor.....	70
DIAGNOSTIC PROCEDURE.....	70

Low Voltage	73
DIAGNOSTIC PROCEDURE	73
Control Unit.....	75
DIAGNOSTIC PROCEDURE	75

TROUBLE DIAGNOSES FOR SYMPTOMS.....77

1. ABS Works Frequently	77
2. Unexpected Pedal Action	77
3. Long Stopping Distance	78
4. ABS Does Not Work.....	79
5. Pedal Vibration and Noise.....	80
6. ABS Warning Lamp Does Not Come On	
When Ignition Switch Is Turned On.....	81
7. ABS Warning Lamp Stays On When Ignition	
Switch Is Turned On.....	84

	TCS	
--	------------	--

DESCRIPTION	86
Purpose.....	86
ABS (Anti-Lock Brake System) Operation	86
ABS Hydraulic Circuit	86
TCS (Traction Control System) Operation	87
System Components	87
System Description.....	87
SENSOR.....	87
CONTROL UNIT	88
ACTUATOR.....	88
Component Parts and Harness Connector	
Location	89
Schematic	90
Wiring Diagram - TCS -	91

ON BOARD DIAGNOSTIC SYSTEM

DESCRIPTION	95
CONSULT-II	95
CONSULT-II APPLICATION TO TCS	95
ECU (ABS/TCS CONTROL UNIT) PART NUMBER	
MODE	95
CONSULT-II Inspection Procedure.....	96
SELF-DIAGNOSIS PROCEDURE.....	96
SELF-DIAGNOSTIC RESULTS MODE.....	97
DATA MONITOR PROCEDURE	98
ACTIVE TEST PROCEDURE	99
DATA MONITOR MODE.....	100
ACTIVE TEST MODE	101

TROUBLE DIAGNOSIS - INTRODUCTION.....102

How to Perform Trouble Diagnoses for Quick	
and Accurate Repair	102
INTRODUCTION.....	102

TROUBLE DIAGNOSIS - BASIC INSPECTION.....103

Preliminary Check.....	103
Ground Circuit Check	106
ABS ACTUATOR AND ELECTRIC UNIT GROUND... 106	

TROUBLE DIAGNOSIS - GENERAL

DESCRIPTION	107
--------------------------	-----

CONTENTS (Cont'd)

Malfunction Code/Symptom Chart.....	107			
CAN COMMUNICATION	109			
System Description.....	109			
FOR A/T MODELS	109			
FOR TCS MODELS	109			
TROUBLE DIAGNOSES FOR SELF-DIAGNOSTIC ITEMS	110			
Wheel Sensor or Rotor.....	110			
DIAGNOSTIC PROCEDURE.....	110			
ABS Actuator Solenoid Valve or Solenoid Valve Relay.....	114			
DIAGNOSTIC PROCEDURE.....	114			
Motor Relay or Motor.....	117			
DIAGNOSTIC PROCEDURE.....	117			
Low Voltage	119			
DIAGNOSTIC PROCEDURE.....	119			
Control Unit.....	121			
DIAGNOSTIC PROCEDURE.....	121			
CAN Communication Line	122			
DIAGNOSTIC PROCEDURE.....	122			
Engine System.....	122			
DIAGNOSTIC PROCEDURE.....	122			
A/T System	123			
DIAGNOSTIC PROCEDURE.....	123			
TROUBLE DIAGNOSES FOR SYMPTOMS	124			
1. ABS Works Frequently	124			
2. Unexpected Pedal Action	124			
3. Long Stopping Distance	125			
4. ABS Does Not Work.....	126			
5. Pedal Vibration and Noise.....	127			
		6. ABS Warning Lamp Does Not Come On When Ignition Switch Is Turned On.....	128	GI
		7. ABS Warning Lamp Stays On When Ignition Switch Is Turned On.....	129	MA
		8. SLIP Indicator Lamp Does Not Come On When Ignition Switch Is Turned On.....	131	EM
		9. TCS OFF Indicator Lamp Does Not Come On When Ignition Switch Is Turned On.....	132	
		10. TCS OFF Switch Is Inoperative	134	LC
		11. Poor Acceleration.....	137	
				EC
		ABS/TCS		
		REMOVAL AND INSTALLATION	138	
		Wheel Sensors	138	FE
		Sensor Rotor.....	138	
		REMOVAL.....	138	
		INSTALLATION.....	139	CL
		ABS Actuator and Electric Unit.....	139	
		REMOVAL.....	139	MT
		INSTALLATION.....	139	
		SERVICE DATA AND SPECIFICATIONS (SDS)	140	AT
		General Specifications.....	140	
		Disc Brake	140	
		Brake Pedal	140	AX
		Parking Brake	140	
		Brake Booster	140	SU
		ABS Wheel Sensor.....	141	

BR

ST

RS

BT

HA

SC

EL

IDX

PRECAUTIONS

Supplemental Restraint System (SRS) "AIR BAG" and "SEAT BELT PRE-TENSIONER"

Supplemental Restraint System (SRS) "AIR BAG" and "SEAT BELT PRE-TENSIONER"

NFBR0127

The Supplemental Restraint System such as "AIR BAG" and "SEAT BELT PRE-TENSIONER" used along with a seat belt, helps to reduce the risk or severity of injury to the driver and front passenger for certain types of collision. The SRS system composition which is available to NISSAN MODEL A33 is as follows:

- For a frontal collision
The Supplemental Restraint System consists of driver air bag module (located in the center of the steering wheel), front passenger air bag module (located on the instrument panel on passenger side), seat belt pre-tensioners, a diagnosis sensor unit, crash zone sensor, warning lamp, wiring harness and spiral cable.
- For a side collision
The Supplemental Restraint System consists of front side air bag module (located in the outer side of front seat), satellite sensor, diagnosis sensor unit (one of components of air bags for a frontal collision), wiring harness, warning lamp (one of components of air bags for a frontal collision).

Information necessary to service the system safely is included in the **RS section** of this Service Manual.

WARNING:

- To avoid rendering the SRS inoperative, which could increase the risk of personal injury or death in the event of a collision which would result in air bag inflation, all maintenance should be performed by an authorized NISSAN dealer.
- Improper maintenance, including incorrect removal and installation of the SRS, can lead to personal injury caused by unintentional activation of the system. For removal of Spiral Cable and Air Bag Module, see the RS section.
- Do not use electrical test equipment on any circuit related to the SRS unless instructed to in this Service Manual. SRS wiring harnesses can be identified by yellow harness connector.

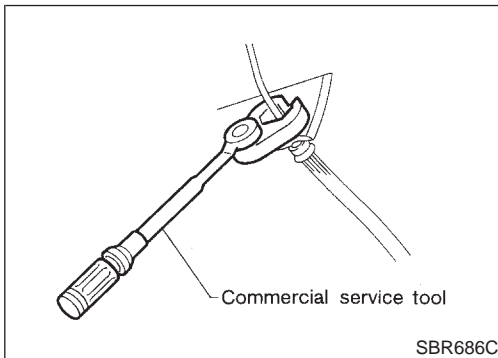

Precautions for Brake System

NFBR0002

- Recommended fluid is brake fluid "DOT 3".
- Never reuse drained brake fluid.
- Be careful not to splash brake fluid on painted areas.
- To clean or wash all parts of master cylinder, disc brake caliper and wheel cylinder, use clean brake fluid.
- Never use mineral oils such as gasoline or kerosene. They will ruin rubber parts of the hydraulic system.
- Use flare nut wrench when removing and installing brake tube.
- Always torque brake lines when installing.
- Burnish the brake contact surfaces after refinishing or replacing drums or rotors, after replacing pads or linings, or if a soft pedal occurs at very low mileage. Refer to "Brake Burnishing Procedure", "ON-VEHICLE SERVICE", BR-8.

WARNING:

- Clean brake pads and shoes with a waste cloth, then wipe with a dust collector.

Wiring Diagrams and Trouble Diagnosis

NFBR0003

When you read wiring diagrams, refer to the following:

- "HOW TO READ WIRING DIAGRAMS" in GI section
- "POWER SUPPLY ROUTING" for power distribution circuit in EL section

When you perform trouble diagnosis, refer to the following:

- "HOW TO FOLLOW TEST GROUP IN TROUBLE DIAGNOSIS" in GI section
- "HOW TO PERFORM EFFICIENT DIAGNOSIS FOR AN ELECTRICAL INCIDENT" in GI section
- For trouble diagnoses of models with ABS, refer to BR-39.
- For trouble diagnoses of models with TCS, refer to BR-86.

GI

MA

EM

LC

EC

FE

CL

MT

AT

AX

SU

BR

ST

RS

BT

HA

SC

EL

IDX

PREPARATION

Commercial Service Tools

Commercial Service Tools

NFBR0004

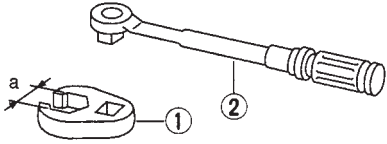
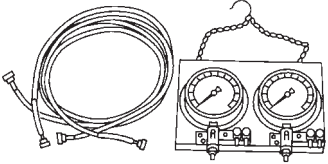
Tool name	Description
1 Flare nut crowfoot 2 Torque wrench	 <p>Removing and installing each brake piping a: 10 mm (0.39 in)</p> <p>NT360</p>
Brake fluid pressure gauge	 <p>Measuring brake fluid pressure</p> <p>NT151</p>

NOISE, VIBRATION AND HARSHNESS (NVH) TROUBLESHOOTING

NVH Troubleshooting Chart

NVH Troubleshooting Chart

NFBR0005S01

Use the chart below to help you find the cause of the symptom. If necessary, repair or replace these parts.

Reference page			BR-23, 27	BR-23, 27	BR-23, 27	—	—	BR-25, 31	—	—	—	BR-26, 32	NVH in AX section	NVH in AX section	NVH in SU section	NVH in SU section	NVH in SU section	NVH in ST section	
Possible cause and SUSPECTED PARTS			Pads - damaged	Pads - uneven wear	Shims damaged	Rotor imbalance	Rotor damage	Rotor runout	Rotor deformation	Rotor deflection	Rotor rust	Rotor thickness variation	DRIVE SHAFT	AXLE	SUSPENSION	TIRES	ROAD WHEEL	STEERING	
Symptom	BRAKE	Noise	X	X	X								X	X	X	X	X	X	
		Shake				X								X	X	X	X	X	X
		Shimmy, Judder				X	X	X	X	X	X	X	X		X	X	X	X	X

X: Applicable

GI
MA
EM
LC
EC
FE
CL
MT
AT
AX
SU
BR
ST
RS
BT
HA
SC
EL
IDX

ON-VEHICLE SERVICE

Checking Brake Fluid Level

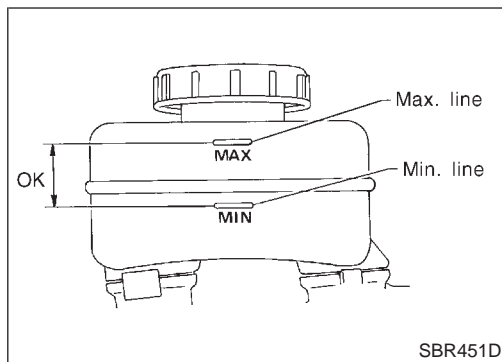

Checking Brake Fluid Level

NFBR0006

- Check fluid level in reservoir tank. It should be between Max and Min lines on reservoir tank.
- If fluid level is extremely low, check brake system for leaks.
- Release parking brake lever and see if brake warning lamp goes off. If not, check brake system for leaks.

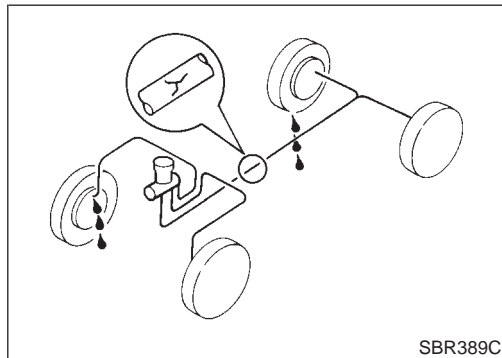

Checking Brake Line

NFBR0007

CAUTION:

If leakage occurs around joints, retighten or, if necessary, replace damaged parts.

1. Check brake lines (tubes and hoses) for cracks, deterioration or other damage. Replace any damaged parts.
2. Check for oil leakage by fully depressing brake pedal while engine is running.

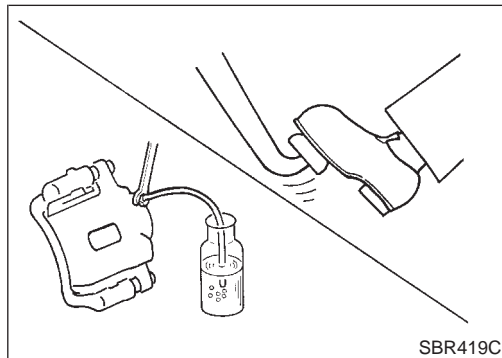

Changing Brake Fluid

NFBR0008

CAUTION:

- Refill with new brake fluid "DOT 3".
- Always keep fluid level higher than minimum line on reservoir tank.
- Never reuse drained brake fluid.
- Be careful not to splash brake fluid on painted areas; it may cause paint damage. If brake fluid is splashed on painted areas, wash it away with water immediately.

1. Clean inside of reservoir tank, and refill with new brake fluid.
2. Connect a vinyl tube to each air bleeder valve.
3. Drain brake fluid from each air bleeder valve by depressing brake pedal.
4. Refill until brake fluid comes out of each air bleeder valve. Use same procedure as in bleeding hydraulic system to refill brake fluid. Refer to "Bleeding Brake System", BR-9.

Brake Burnishing Procedure

NFBR0036

Burnish the brake contact surfaces according to the following procedure after refinishing or replacing drums or rotors, after replacing pads or linings, or if a soft pedal occurs at very low mileage.

CAUTION:

Only perform this procedure under safe road and traffic conditions. Use extreme caution.

1. Drive the vehicle on a straight smooth road at 50 km/h (31 MPH).
2. Use medium brake pedal/foot effort to bring the vehicle to a complete stop from 50 km/h (31 MPH). Adjust brake pedal/foot

pressure such that vehicle stopping time equals 3 to 5 seconds.

3. To cool the brake system, drive the vehicle at 50 km/h (31 MPH) for 1 minute without stopping.
4. Repeat steps 1 to 3, 10 times or more to complete the burnishing procedure.

GI
MA
EM

EM

LC

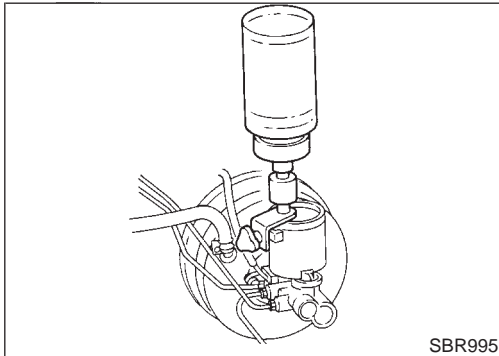

Bleeding Brake System

NFBR0009

CAUTION:

- Carefully monitor brake fluid level at master cylinder during bleeding operation.
- Fill reservoir with new brake fluid “DOT 3”. Make sure it is full at all times while bleeding air out of system.
- Place a container under master cylinder to avoid spillage of brake fluid.
- For models with ABS, turn ignition switch OFF and disconnect ABS actuator connectors or battery ground cable.

EC

FE

CL

MT

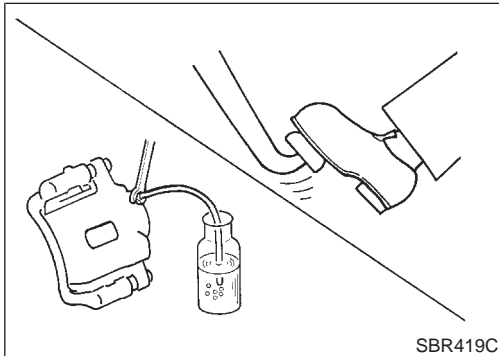

- Bleed air in the following order:
Right rear brake → Left front brake → Left rear brake → Right front brake
1. Connect a transparent vinyl tube to air bleeder valve.
 2. Fully depress brake pedal several times.
 3. With brake pedal depressed, open air bleeder valve to release air.
 4. Close air bleeder valve.
 5. Release brake pedal slowly.
 6. Repeat steps 2. through 5. until clear brake fluid comes out of air bleeder valve.

AT

AX

SU

BR

ST

RS

BT

HA

SC

EL

IDX

BRAKE HYDRAULIC LINE

Hydraulic Circuit

Hydraulic Circuit

NFBR0010

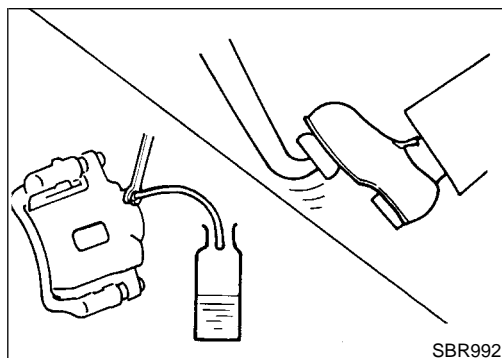
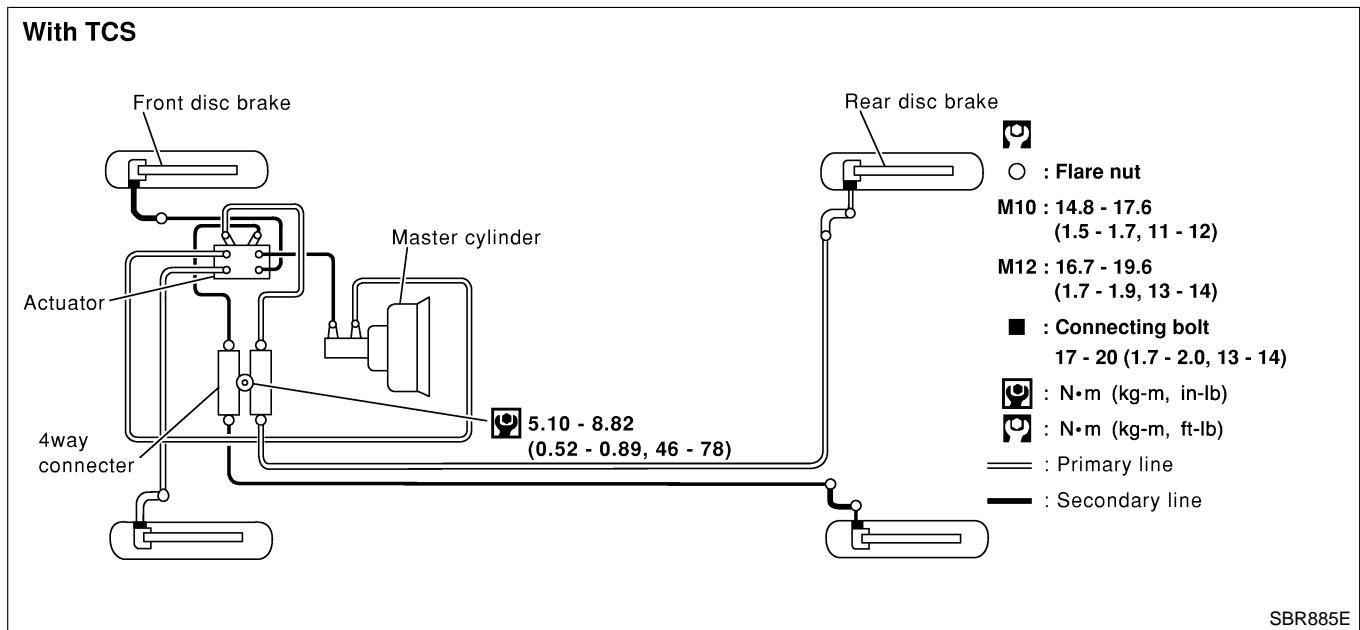
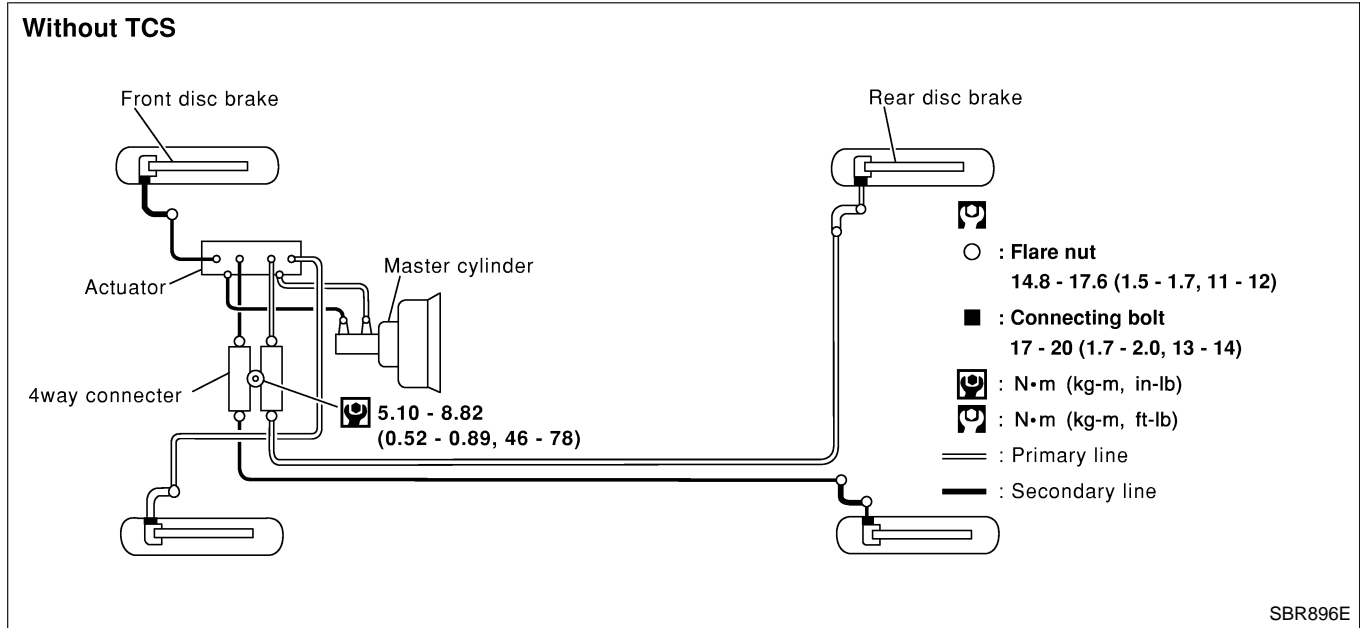

Removal

CAUTION:

- Be careful not to splash brake fluid on painted areas; it may cause paint damage. If brake fluid is splashed on painted areas, wash it away with water immediately.
 - All hoses must be free from excessive bending, twisting and pulling.
1. Connect vinyl tube to air bleeder valve.
 2. Drain brake fluid from each air bleeder valve by depressing brake pedal.

NFBR0011

3. Remove flare nut connecting brake tube and hose, then withdraw lock spring.
4. Cover openings to prevent entrance of dirt whenever disconnecting brake line.

GI

MA

EM

LC

Inspection

Check brake lines (tubes and hoses) for cracks, deterioration or other damage. Replace any damaged parts.

NFBR0012

EC

FE

CL

MT

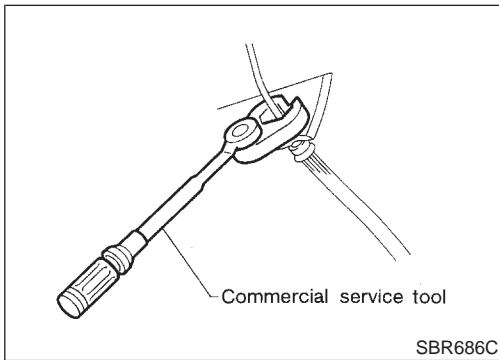

Installation

CAUTION:

- Refill with new brake fluid "DOT 3".
- Never reuse drained brake fluid.

1. Tighten all flare nuts and connecting bolts.

Specification:

Flare nut

M10: 14.8 - 17.6 N·m (1.5 - 1.7 kg-m, 11 - 12 ft-lb)

M12: 16.7 - 19.6 N·m (1.7 - 1.9 kg-m, 13 - 14 ft-lb)

Connecting bolt

17 - 20 N·m (1.8 - 2.0 kg-m, 13 - 14 ft-lb)

2. Refill until new brake fluid comes out of each air bleeder valve.
3. Bleed air. Refer to "Bleeding Brake System", BR-9.

NFBR0013

AT

AX

SU

BR

ST

RS

BT

HA

SC

EL

IDX

BRAKE PEDAL AND BRACKET

Removal and Installation

Removal and Installation

NFBR0015

SEC. 465•470

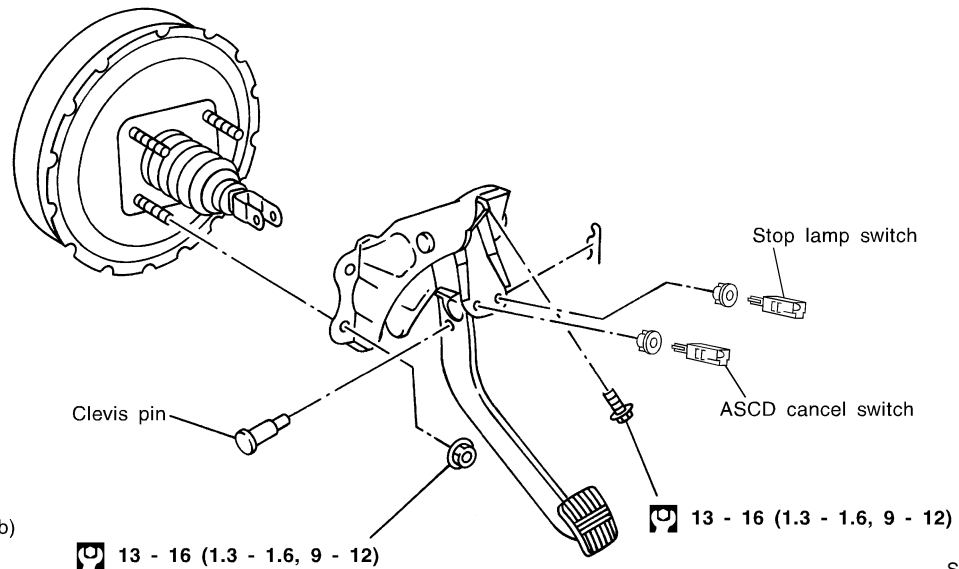

: N·m (kg-m, ft-lb)

13 - 16 (1.3 - 1.6, 9 - 12)

SBR525EB

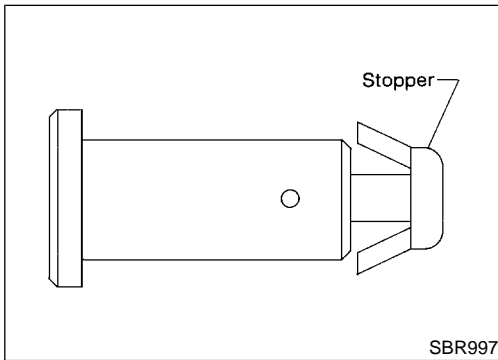

Inspection

NFBR0016

Check brake pedal for following items.

- Brake pedal bend
- Clevis pin deformation
- Crack of any welded portion
- Crack or deformation of clevis pin stopper

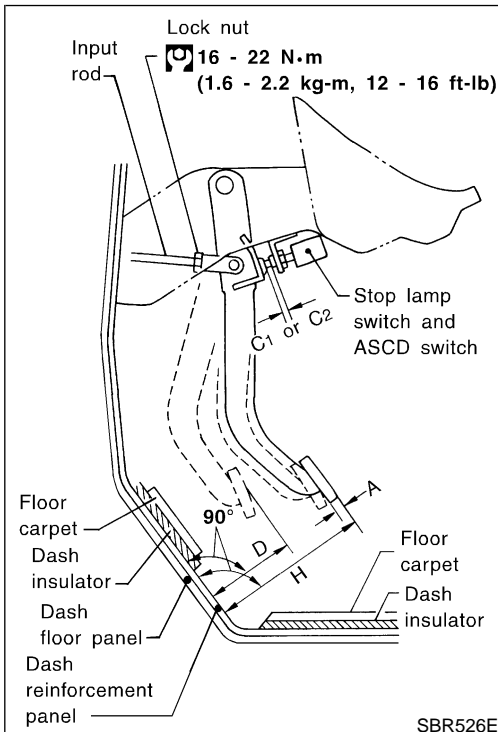

Adjustment

NFBR0017

Check brake pedal free height from metal panel. Adjust if necessary.

H: Free height

Refer to SDS, BR-140.

C₁, C₂: Clearance between pedal stopper and threaded end of stop lamp switch and ASCD switch

0.74 - 1.96 mm (0.0291 - 0.0772 in)

D: Depressed height

82.5 mm (3.248 in)

Under force of 490 N (50 kg, 110 lb) with engine running.

A: Pedal play

3 - 11 mm (0.12 - 0.43 in)

BRAKE PEDAL AND BRACKET

Adjustment (Cont'd)

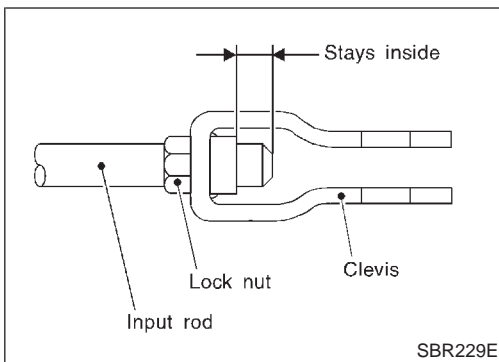

1. Loosen lock nut and adjust pedal free height by turning brake booster input rod. Then tighten lock nut.
2. Check pedal free play.
Make sure that stop lamps go off when pedal is released.
3. Check brake pedal's depressed height while engine is running. If lower than specification, check brake system for leaks, accumulation of air or any damage to components (master cylinder, wheel cylinder, etc.); then make necessary repairs.

GI

MA

EM

LC

EC

FE

CL

MT

AT

AX

SU

BR

ST

RS

BT

HA

SC

EL

IDX

MASTER CYLINDER (TOKICO)

Removal

Removal

NFBR0018

TOKICO made
SEC. 460

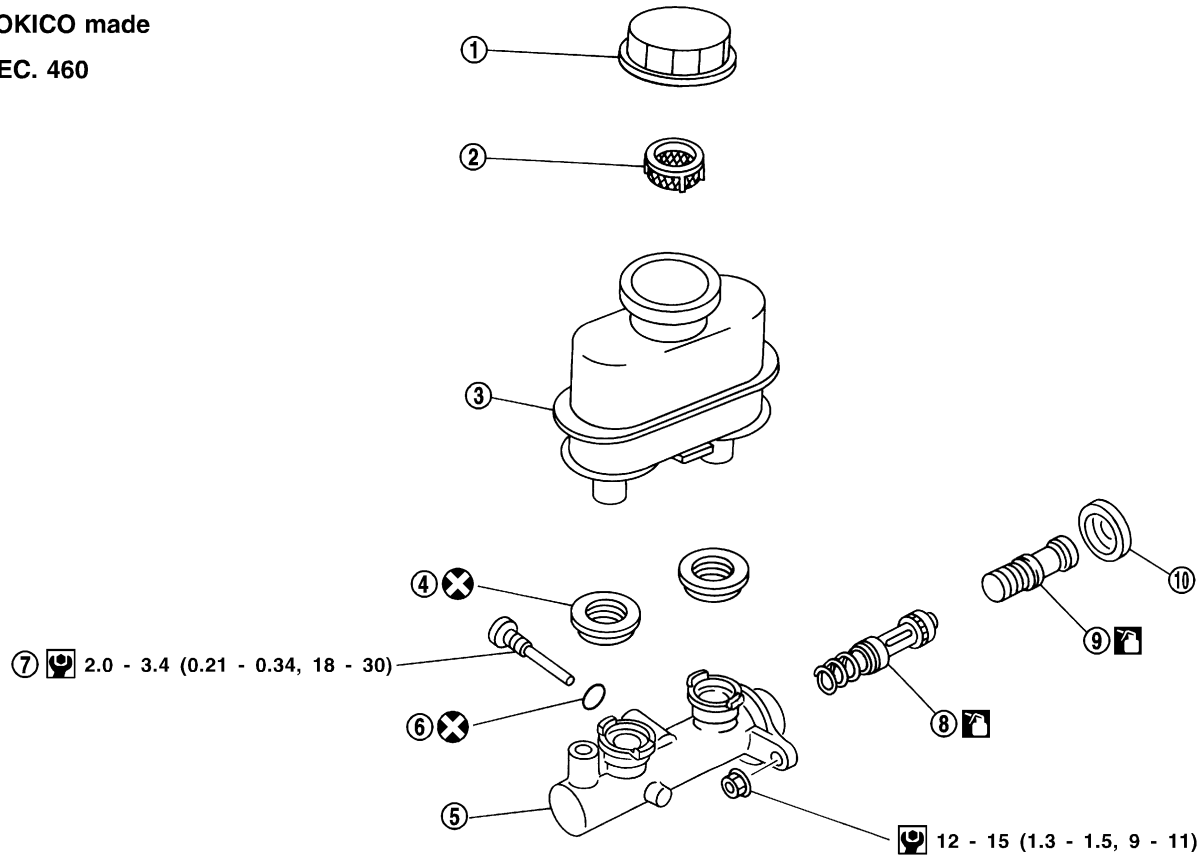

- : Brake fluid
- : N•m (kg-m, ft-lb)
- : N•m (kg-m, in-lb)

SBR886E

- | | | |
|-------------------|-------------------|------------------------------|
| 1. Reservoir cap | 5. Cylinder body | 8. Secondary piston assembly |
| 2. Oil filter | 6. O-ring | 9. Primary piston assembly |
| 3. Reservoir tank | 7. Piston stopper | 10. Stopper cap |
| 4. Seal | | |

CAUTION:

Be careful not to splash brake fluid on painted areas; it may cause paint damage. If brake fluid is splashed on painted areas, wash it away with water immediately.

1. Connect a vinyl tube to air bleeder valve.
2. Drain brake fluid from each air bleeder valve, depressing brake pedal to empty fluid from master cylinder.
3. Remove brake pipe flare nuts.
4. Remove master cylinder mounting nuts.

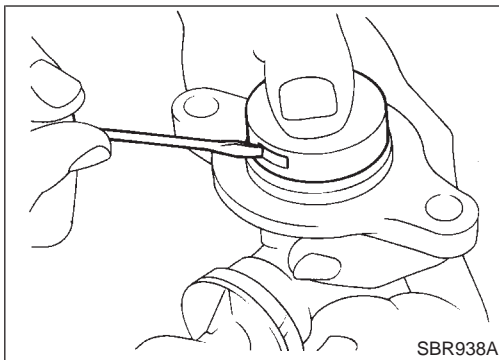

Disassembly

NFBR0019

1. Bend claws of stopper cap outward and remove stopper cap.

GI

MA

EM

LC

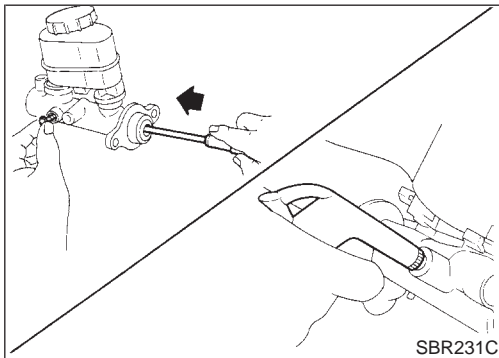

2. Remove valve stopper while piston is pushed into cylinder.
3. Remove piston assemblies.
If it is difficult to remove secondary piston assembly, gradually apply compressed air through fluid outlet.
4. Draw out reservoir tank.

EC

FE

CL

MT

Inspection

NFBR0020

Check for the following items.
Replace any part if damaged.
Master cylinder:

- Pin holes or scratches on inner wall.

AT

AX

Piston:

- Deformation of or scratches on piston cups.

SU

BR

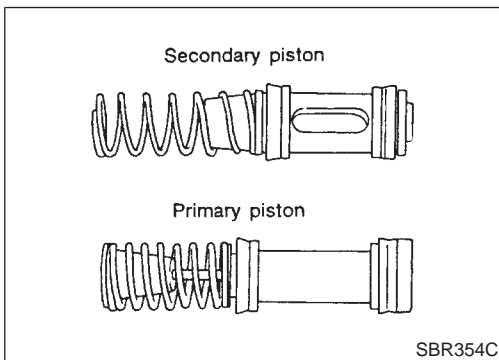

Assembly

NFBR0021

1. Insert secondary piston assembly. Then insert primary piston assembly.
● Pay attention to alignment of secondary piston slit with valve stopper mounting hole of cylinder body.

ST

RS

BT

HA

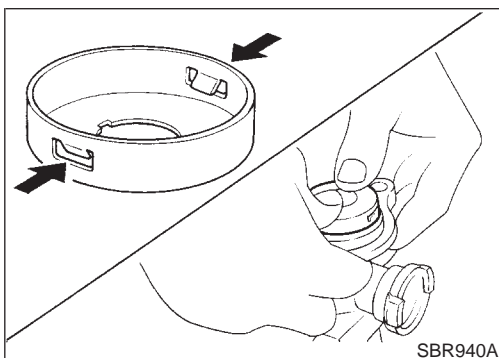

2. Install stopper cap.
Before installing stopper cap, ensure that claws are bent inward.
3. Push reservoir tank seals into cylinder body.
4. Push reservoir tank into cylinder body.

SC

EL

IDX

MASTER CYLINDER (TOKICO)

Assembly (Cont'd)

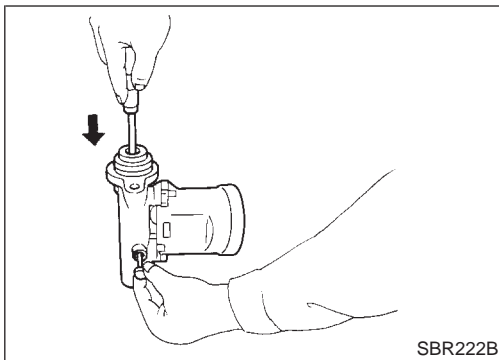

5. Install valve stopper while piston is pushed into cylinder.

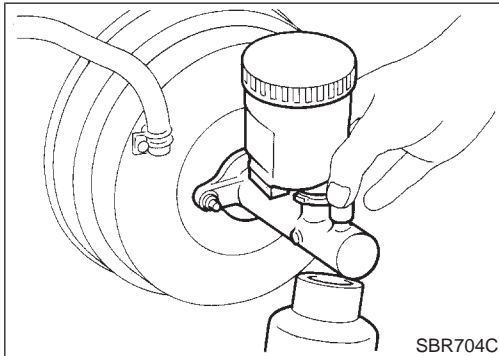

Installation

NFBR0022

CAUTION:

- Refill with new brake fluid "DOT 3".
 - Never reuse drained brake fluid.
1. Place master cylinder onto brake booster and secure mounting nuts lightly.
 2. Torque mounting nuts.
☑ : 12 - 15 N·m (1.3 - 1.5 kg-m, 9 - 11 ft-lb)
 3. Fill up reservoir tank with new brake fluid.
 4. Plug all ports on master cylinder with fingers to prevent air suction while releasing brake pedal.
 5. Have driver depress brake pedal slowly several times until no air comes out of master cylinder.
 6. Fit brake lines to master cylinder.
 7. Tighten flare nuts.
M10: ☑ 14.8 - 17.6 N·m (1.5 - 1.7 kg-m, 11 - 12 ft-lb)
M12: ☑ 16.7 - 19.6 N·m (1.7 - 1.9 kg-m, 13 - 14 ft-lb)
 8. Bleed air from brake system. Refer to "Bleeding Brake System", BR-9.

MASTER CYLINDER [BOSCH (NABCO)]

Removal

Removal

NFBR0095

BOSCH (NABCO) made
SEC. 460

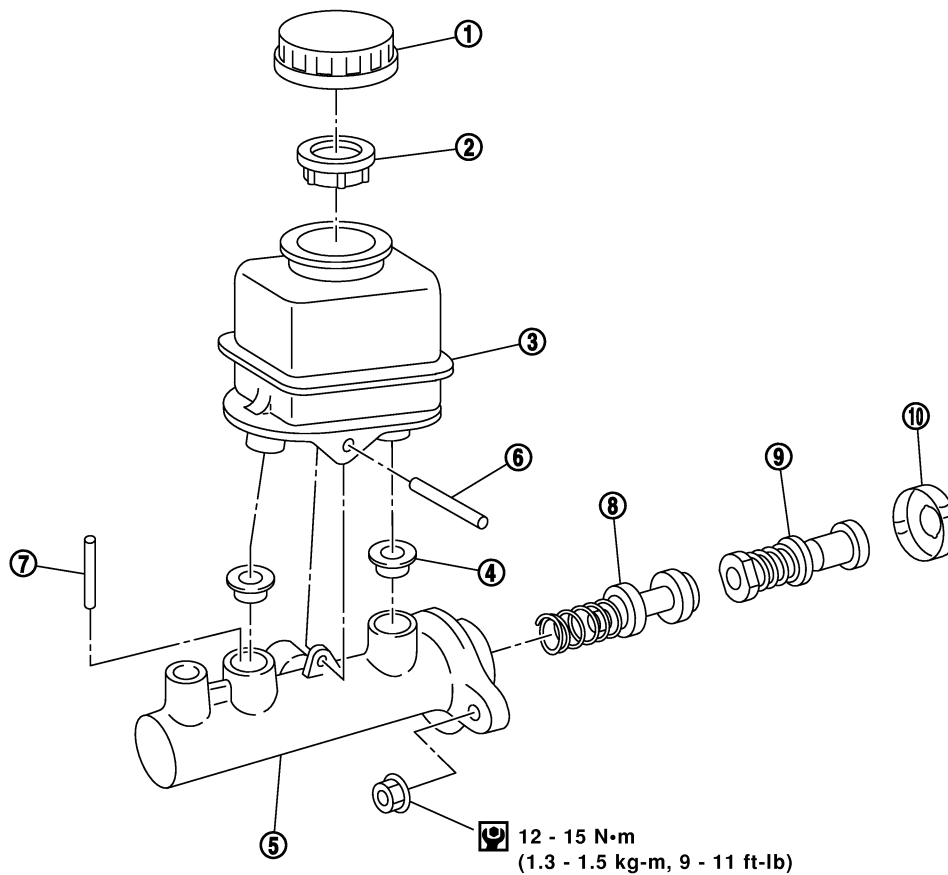

SBR976E

1. Reservoir cap
2. Oil filter
3. Reservoir tank
4. Seal

5. Cylinder body
6. Spring pin
7. Piston stopper pin

8. Secondary piston assembly
9. Primary piston assembly
10. Stopper cap

CAUTION:

Be careful not to splash brake fluid on painted areas; it may cause paint damage. If brake fluid is splashed on painted areas, wash it away with water immediately.

1. Connect a vinyl tube to air bleeder valve.
2. Drain brake fluid from each air bleeder valve, depressing brake pedal to empty fluid from master cylinder.
3. Remove brake pipe flare nuts.
4. Remove master cylinder mounting nuts.

GI
MA
EM
LC
EC
FE
CL
MT
AT
AX
SU

BR

ST

RS

BT

HA

SC

EL

IDX

MASTER CYLINDER [BOSCH (NABCO)]

Disassembly

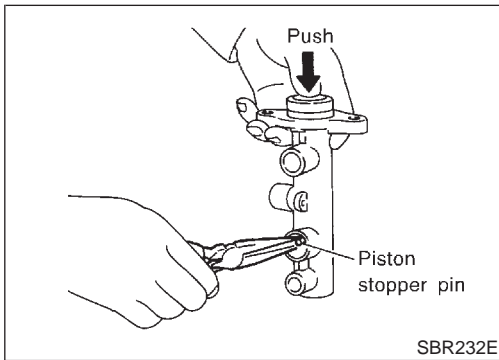
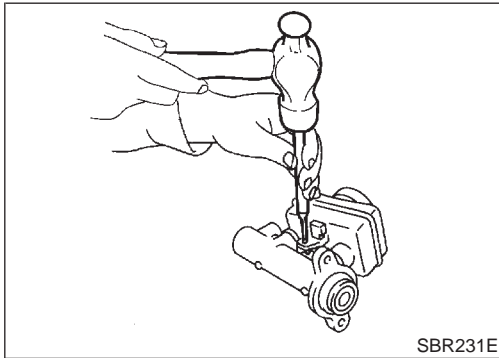
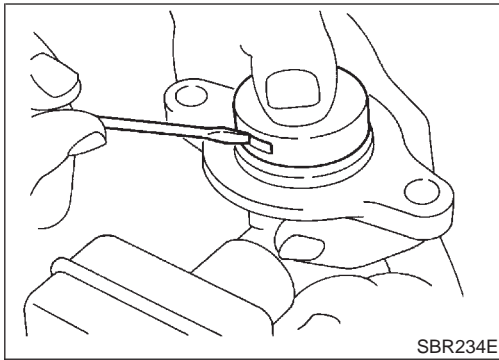

Disassembly

NFBR0096

1. Bend claws of stopper cap outward and remove stopper cap.
2. Drive out spring pin from cylinder body.
3. Draw out reservoir tank and seals.
4. Remove piston stopper pin while piston is pushed into cylinder.
5. Remove piston assemblies.
If it is difficult to remove secondary piston assembly, gradually apply compressed air through fluid outlet.

Inspection

NFBR0097

Check for the following items.
Replace any part if damaged.
Master cylinder:

- Pin holes or scratches on inner wall.

Piston:

- Deformation of or scratches on piston cups.

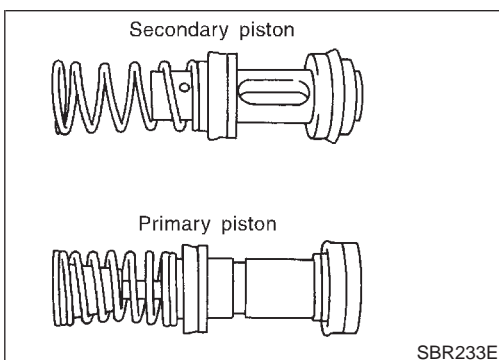

Assembly

NFBR0098

1. Insert secondary piston assembly. Then insert primary piston assembly.
- **Pay attention to alignment of secondary piston slit with valve stopper mounting hole of cylinder body.**

MASTER CYLINDER [BOSCH (NABCO)]

Assembly (Cont'd)

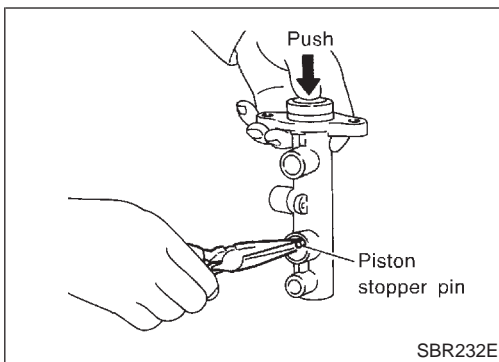

2. Install piston stopper pin while piston is pushed into cylinder.
3. Push reservoir tank seals and reservoir tank into cylinder body.
4. Install spring pin.

GI

MA

EM

LC

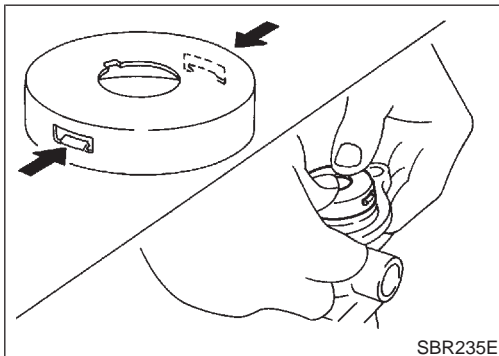

5. Install stopper cap.

Before installing stopper cap, ensure that claws are bent inward.

EC

FE

CL

MT

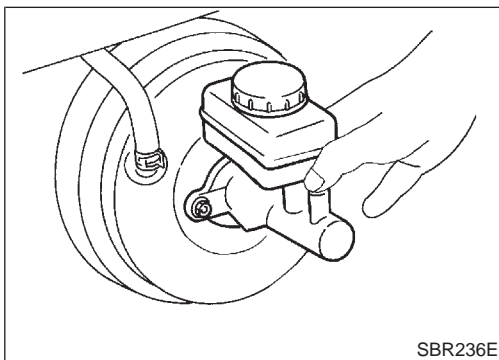

Installation

NFBR0099

AT

CAUTION:

- Refill with new brake fluid "DOT 3".
- Never reuse drained brake fluid.

AX

1. Place master cylinder onto brake booster and secure mounting nuts lightly.
2. Torque mounting nuts.

SU

⚙️ : 12 - 15 N·m (1.3 - 1.5 kg·m, 9 - 11 ft·lb)

3. Fill up reservoir tank with new brake fluid.
4. Plug all ports on master cylinder with fingers to prevent air suction while releasing brake pedal.
5. Have driver depress brake pedal slowly several times until no air comes out of master cylinder.
6. Fit brake lines to master cylinder.
7. Tighten flare nuts.

BR

ST

RS

M10: ⚙️ 14.8 - 17.6 N·m (1.5 - 1.7 kg·m, 11 - 12 ft·lb)

M12: ⚙️ 16.7 - 19.6 N·m (1.7 - 1.9 kg·m, 13 - 14 ft·lb)

BT

8. Bleed air from brake system.

HA

SC

EL

IDX

BRAKE BOOSTER

On-vehicle Service

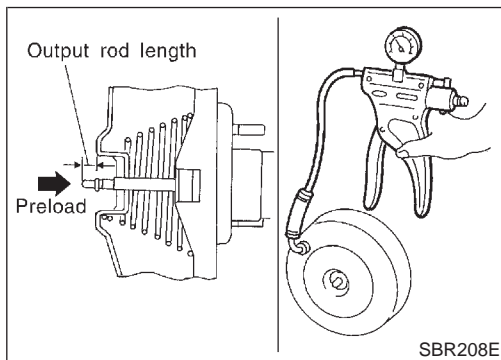
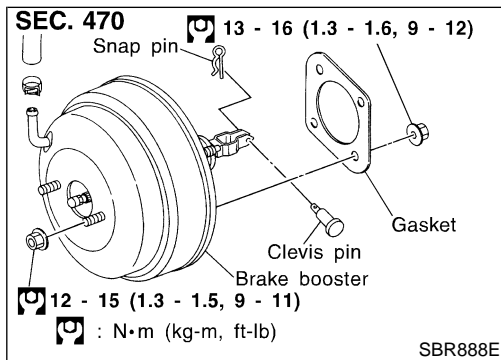
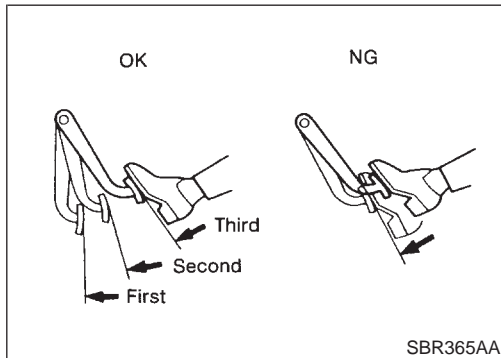
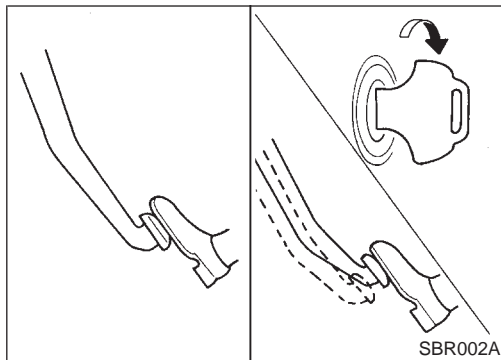

On-vehicle Service

NFBR0023

OPERATING CHECK

NFBR0023S01

1. Stop engine and depress brake pedal several times. Check that pedal stroke does not change.
2. Depress brake pedal, then start engine. If pedal goes down slightly, operation is normal.

AIRTIGHT CHECK

NFBR0023S02

1. Start engine, and stop it after one or two minutes. Depress brake pedal several times slowly. The pedal should go further down the first time, and then it should gradually rise thereafter.
2. Depress brake pedal while engine is running, and stop engine with pedal depressed. The pedal stroke should not change after holding pedal down for **30 seconds**.

Removal

NFBR0024

CAUTION:

- Be careful not to splash brake fluid on painted areas; it may cause paint damage. If brake fluid is splashed on painted areas, wash it away with water immediately.
- Be careful not to deform or bend brake pipes, during removal of booster.

Inspection

NFBR0025

OUTPUT ROD LENGTH CHECK

NFBR0025S01

1. Apply vacuum of -66.7 kPa (-500 mmHg, -19.69 inHg) to brake booster with a handy vacuum pump.
2. Add preload of 19.6 N (2 kg, 4.4 lb) to output rod.
3. Check output rod length.

Specified length:

10.275 - 10.525 mm (0.4045 - 0.4144 in)

Installation

NFBR0026

CAUTION:

- Be careful not to deform or bend brake pipes, during installation of booster.
- Replace clevis pin if damaged.
- Refill with new brake fluid "DOT 3".
- Never reuse drained brake fluid.
- Take care not to damage brake booster mounting bolt thread when installing. Due to the acute angle of installation, the threads can be damaged with the dash panel.

BRAKE BOOSTER

Installation (Cont'd)

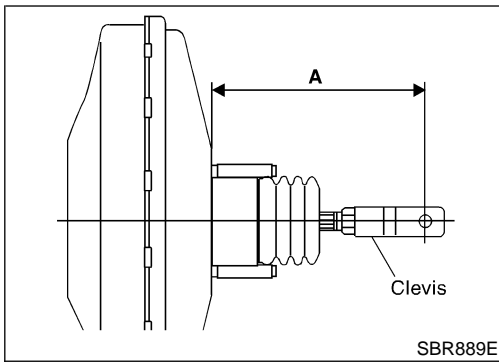

1. Before fitting booster, temporarily adjust clevis to dimension "A" shown.

Specification:

130 mm (5.12 in)

2. Fit booster, then secure mounting nuts (brake pedal bracket to master cylinder) lightly.
3. Connect brake pedal and booster input rod with clevis pin.
4. Secure mounting nuts.

Specification:

15.7 - 21.6 N·m (1.6 - 2.2 kg-m, 12 - 15 ft-lb)

5. Install master cylinder. Refer to "Installation" in "MASTER CYLINDER", BR-16 or BR-19.
6. Bleed air. Refer to "Bleeding Brake System", BR-9.

GI

MA

EM

LC

EC

FE

CL

MT

AT

AX

SU

BR

ST

RS

BT

HA

SC

EL

IDX

VACUUM HOSE

Removal and Installation

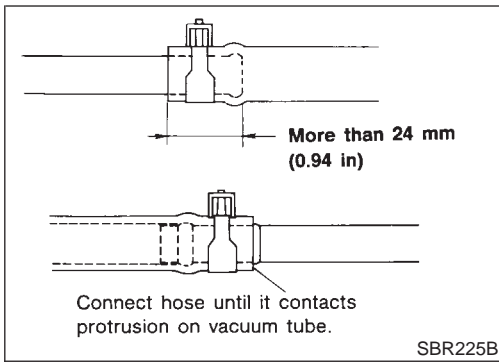

Removal and Installation

NFBR0027

CAUTION:

When installing vacuum hoses, pay attention to the following points.

- Do not apply any oil or lubricants to vacuum hose and check valve.
- Insert vacuum tube into vacuum hose as shown.
- Install check valve, paying attention to its direction.

Inspection

NFBR0028

HOSES AND CONNECTORS

NFBR0028S01

Check vacuum lines, connections and check valve for airtightness, improper attachment chafing and deterioration.

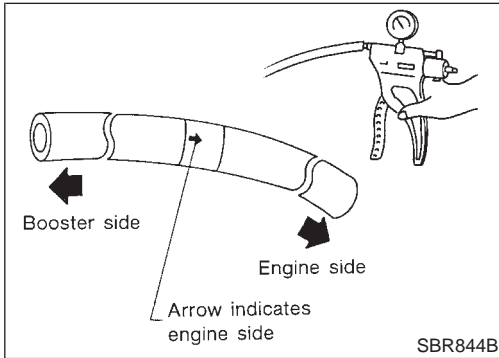

CHECK VALVE

NFBR0028S02

Check vacuum with a vacuum pump.

Connect to booster side	Vacuum should exist.
Connect to engine side	Vacuum should not exist.

Component

NFBR0030

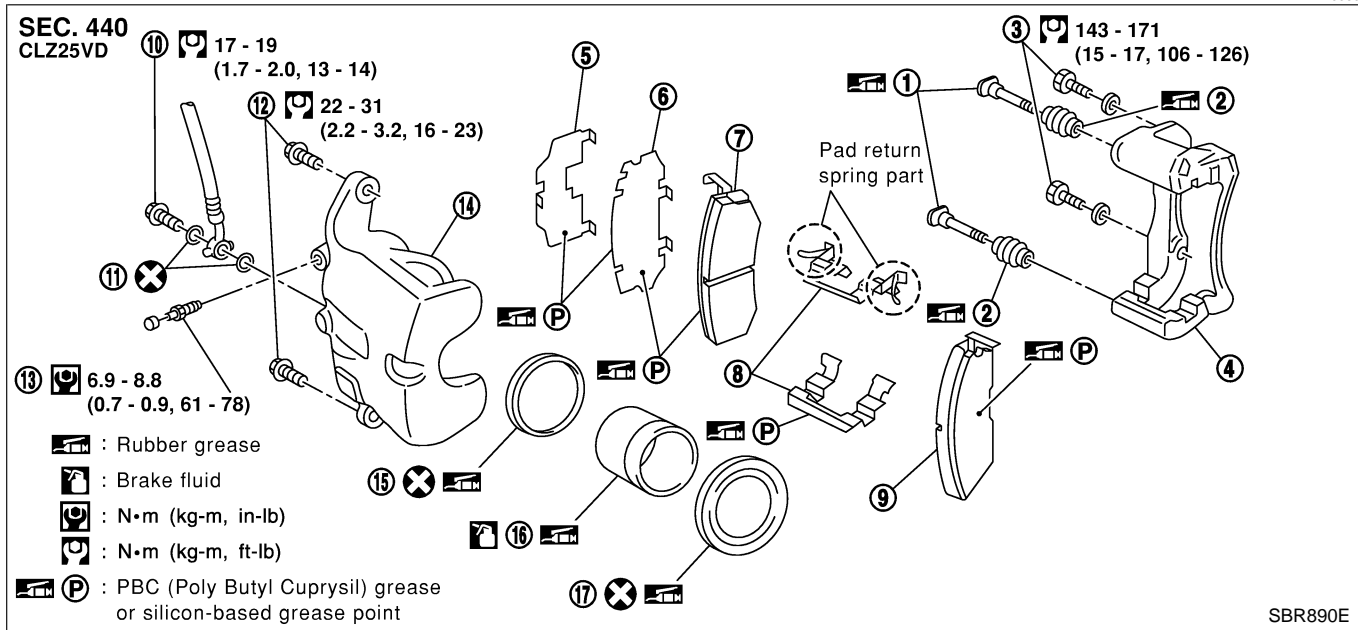

- | | | |
|------------------------------|---------------------|-------------------|
| 1. Main pin | 7. Inner pad | 13. Bleed valve |
| 2. Pin boot | 8. Pad retainer | 14. Cylinder body |
| 3. Torque member fixing bolt | 9. Outer pad | 15. Piston seal |
| 4. Torque member | 10. Connecting bolt | 16. Piston |
| 5. Shim cover | 11. Copper washer | 17. Piston boot |
| 6. Inner shim | 12. Main pin bolt | |

Pad Replacement

NFBR0029

WARNING:

Clean brake pads with a vacuum dust collector to minimize the hazard of airborne particles or other materials.

CAUTION:

- When cylinder body is open, do not depress brake pedal because piston will pop out.
- Be careful not to damage piston boot or get oil on rotor. Always replace shims when replacing pads.
- If shims are rusted or show peeling of the rubber coat, replace them with new shims.
- It is not necessary to remove connecting bolt except for disassembly or replacement of caliper assembly. In this case, suspend cylinder body with wire so as not to stretch brake hose.
- Burnish the brake contact surfaces after refinishing or replacing drums or rotors, after replacing pads or linings, or if a soft pedal occurs at very low mileage. Refer to "Brake Burnishing Procedure", "ON-VEHICLE SERVICE", BR-8.

GI
MA
EM
LC
EC
FE
CL
MT
AT
AX
SU
BR
ST
RS
BT
HA
SC
EL
IDX

FRONT DISC BRAKE

Pad Replacement (Cont'd)

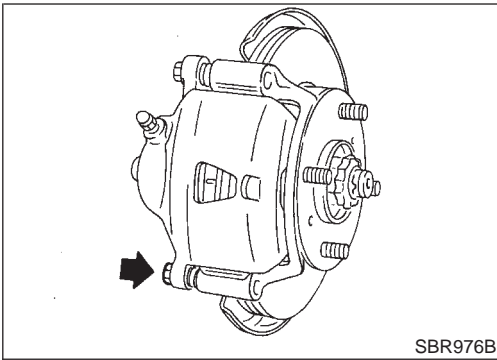

1. Remove master cylinder reservoir cap.
2. Remove pin bolt.
3. Open cylinder body upward. Then remove pad with retainers, inner shim.

Standard pad thickness:

9.5 mm (0.374 in)

Pad wear limit:

2.0 mm (0.079 in)

Carefully monitor brake fluid level because brake fluid will return to reservoir when pushing back piston.

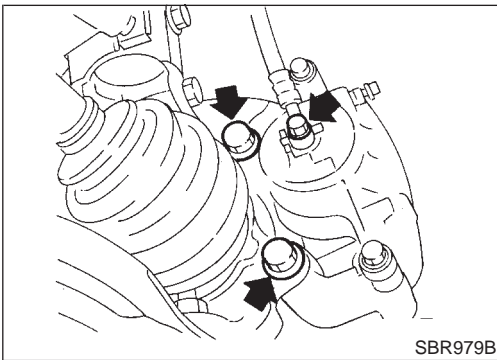
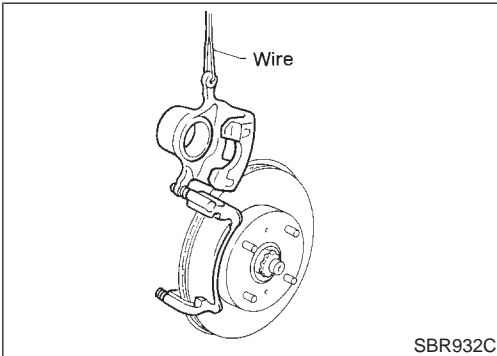

Removal

NFBR0031

WARNING:

Clean brake pads with a vacuum dust collector to minimize the hazard of airborne particles or other materials.

Remove torque member fixing bolts and connecting bolt. It is not necessary to remove connecting bolt except for disassembly or replacement of caliper assembly. In this case, suspend caliper assembly with wire so as not to stretch brake hose.

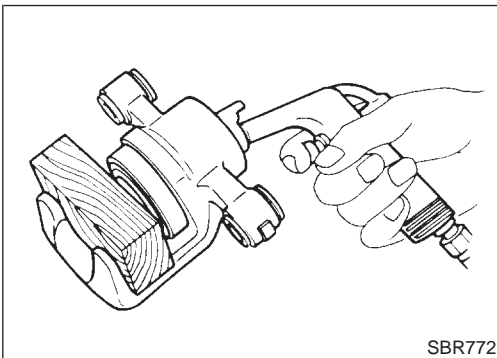

Disassembly

NFBR0032

WARNING:

Do not place your fingers in front of piston.

CAUTION:

Do not scratch or score cylinder wall.

1. Push out piston with piston boot with compressed air.
2. Remove piston seal with a suitable tool.

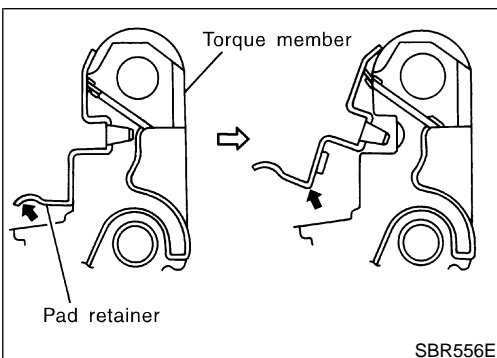

CAUTION:

When removing the pad retainer from the torque member, lift it up and out in the direction of the arrows in the figure.

Inspection**CALIPER**

NFBR0033

Cylinder Body

NFBR0033S01

- Check inside surface of cylinder for score, rust, wear, damage or presence of foreign materials. If any of the above conditions are observed, replace cylinder body.
- Minor damage from rust or foreign materials may be eliminated by polishing surface with a fine emery paper. Replace cylinder body if necessary.

CAUTION:

Use brake fluid to clean. Never use mineral oil.

Piston

NFBR0033S0102

CAUTION:

Piston sliding surface is plated. Do not polish with emery paper even if rust or foreign materials are stuck to sliding surface.

Check piston for score, rust, wear, damage or presence of foreign materials. Replace if any of the above conditions are observed.

Slide Pin, Pin Bolt and Pin Boot

NFBR0033S0103

Check for wear, cracks or other damage. Replace if any of the above conditions are observed.

ROTOR

NFBR0033S02

Rubbing Surface

NFBR0033S0201

Check rotor for roughness, cracks or chips.

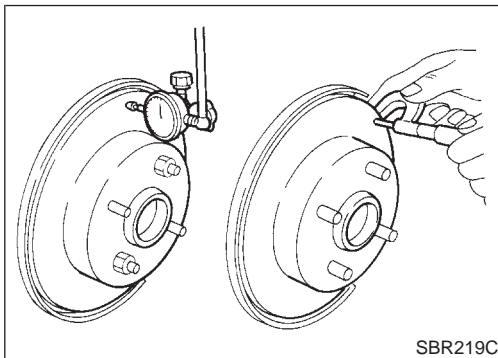
**Runout**

NFBR0033S0202

1. Secure rotor to wheel hub with at least two nuts (M12 x 1.25).
2. Check runout using a dial indicator. **Make sure that wheel bearing axial end play is within the specifications before measuring. Refer to AX section ("Front Wheel Bearing", "ON-VEHICLE SERVICE").**

Maximum runout:**0.07 mm (0.0028 in)**

3. If the runout is out of specification, find minimum runout position as follows:
 - a. Remove nuts and rotor from wheel hub.
 - b. Shift the rotor one hole and secure rotor to wheel hub with nuts.
 - c. Measure runout.
 - d. Repeat steps a. to c. so that minimum runout position can be found.
4. If the runout is still out of specification, turn rotor with on-car brake lathe ("MAD DL-8700", "AMMCO 700 and 705" or equivalent).

FRONT DISC BRAKE

Inspection (Cont'd)

Thickness

**Thickness variation (At least 8 positions):
Maximum 0.01 mm (0.0004 in)**

NFBR0033S0203

If thickness variation exceeds the specification, turn rotor with on-car brake lathe.

**Rotor repair limit:
22.0 mm (0.866 in)**

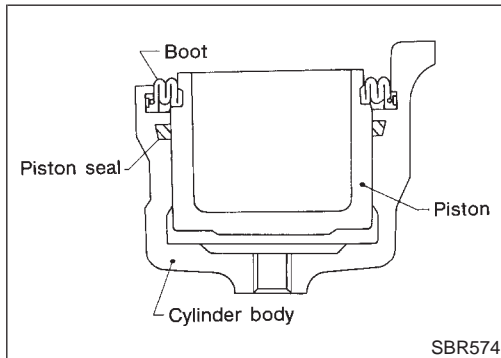

Assembly

NFBR0034

1. Insert piston seal into groove on cylinder body.
2. With piston boot fitted to piston, insert piston boot into groove on cylinder body and install piston.
3. Properly secure piston boot.

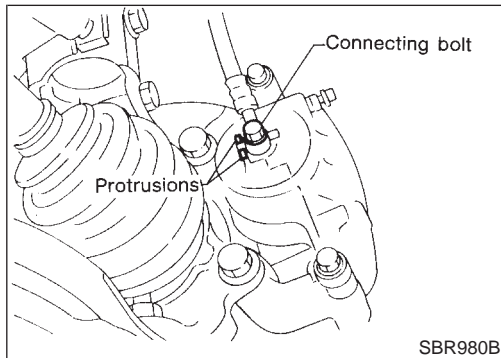

Installation

NFBR0035

CAUTION:

- Refill with new brake fluid "DOT 3".
- Never reuse drained brake fluid.

1. Install brake hose to caliper securely.
2. Install all parts and secure all bolts.
3. Bleed air. Refer to "Bleeding Brake System", BR-9.

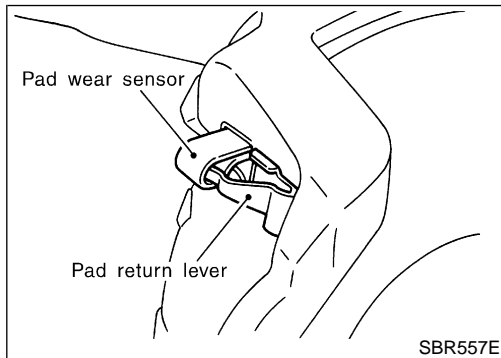

CAUTION:

The upper pad retainer is built so the pad returns to its original position. Be careful to install the pad-return lever securely to the pad wear sensor, as shown in the left figure.

REAR DISC BRAKE

Component

Component

NFBR0038

SEC. 441

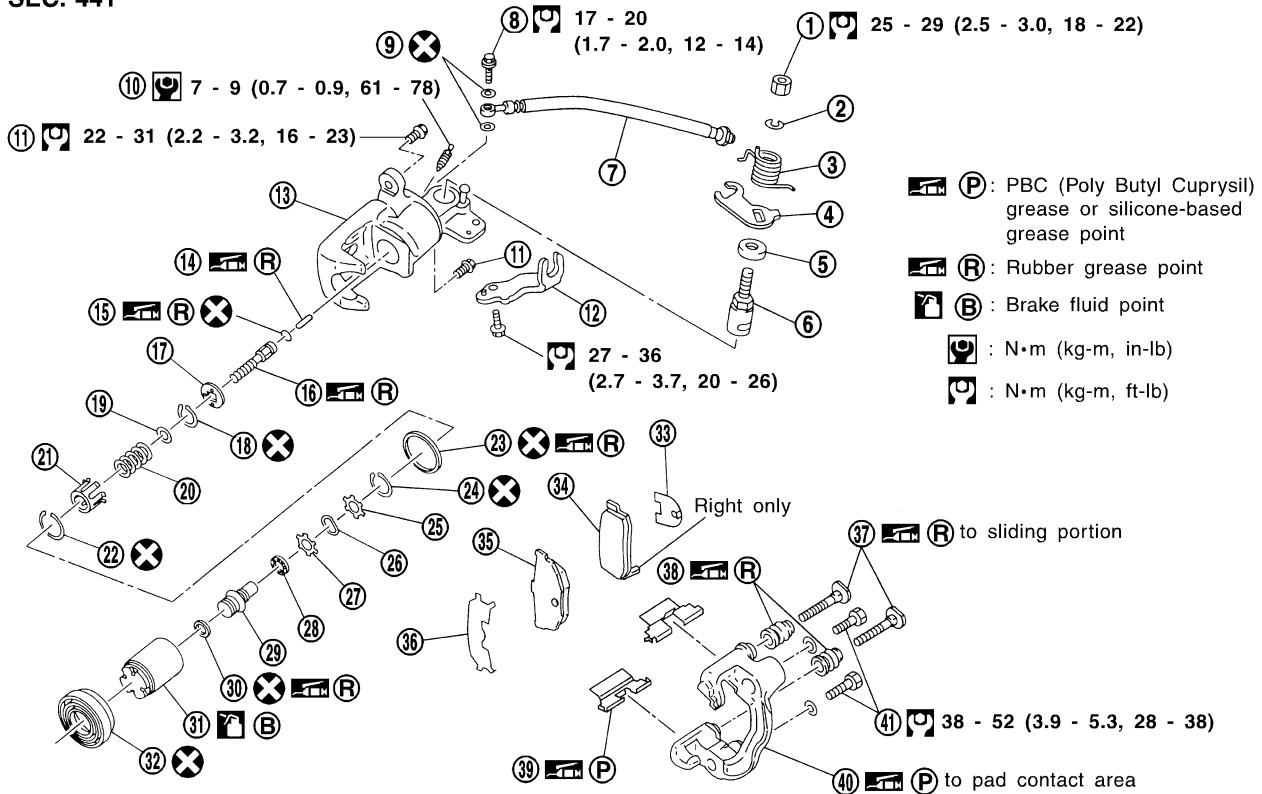

SBR897E

- | | | |
|----------------------------|------------------|-------------------------------|
| 1. Nut | 15. O-ring | 29. Adjust nut |
| 2. Washer | 16. Push rod | 30. Cup |
| 3. Return spring | 17. Key plate | 31. Piston |
| 4. Toggle lever | 18. Ring C | 32. Dust seal |
| 5. Cam boot | 19. Seat | 33. Inner shim |
| 6. Cam | 20. Spring | 34. Inner pad |
| 7. Brake hose | 21. Spring cover | 35. Outer pad |
| 8. Connecting bolt | 22. Ring B | 36. Outer shim |
| 9. Copper washer | 23. Piston seal | 37. Pin |
| 10. Bleed screw | 24. Ring A | 38. Pin boot |
| 11. Pin bolt | 25. Spacer | 39. Pad retainer |
| 12. Cable mounting bracket | 26. Wave washer | 40. Torque member |
| 13. Cylinder | 27. Spacer | 41. Torque member fixing bolt |
| 14. Strut | 28. Ball bearing | |

Pad Replacement

NFBR0037

WARNING:

Clean brake pads with a vacuum dust collector to minimize the hazard of airborne particles or other materials.

CAUTION:

- When cylinder body is open, do not depress brake pedal because piston will pop out.
- Be careful not to damage piston boot or get oil on rotor. Always replace shims in replacing pads.
- If shims are rusted or show peeling of rubber coat, replace them with new shims.

BR-27

GI

MA

EM

LC

EC

FE

CL

MT

AT

AX

SU

BR

ST

RS

BT

HA

SC

EL

IDX

REAR DISC BRAKE

Pad Replacement (Cont'd)

- It is not necessary to remove connecting bolt except for disassembly or replacement of caliper assembly. In this case, suspend cylinder body with wire so as not to stretch brake hose.
- Burnish the brake contact surfaces after refinishing or replacing drums or rotors, after replacing pads or linings, or if a soft pedal occurs at very low mileage. Refer to "Brake Burnishing Procedure", "ON-VEHICLE SERVICE", BR-8.

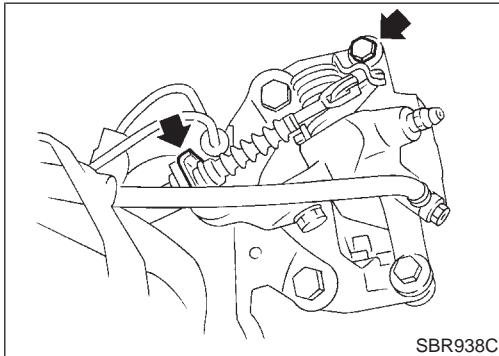

1. Remove master cylinder reservoir cap.
2. Remove brake cable mounting bolt and lock spring.
3. Release parking brake control lever, then disconnect cable from the caliper.
4. Remove upper pin bolt.
5. Open cylinder body downward. Then remove pad with retainers and inner and outer shims.

Standard pad thickness:

10 mm (0.39 in)

Pad wear limit:

1.5 mm (0.059 in)

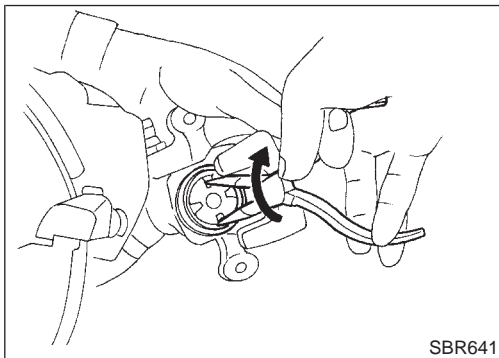
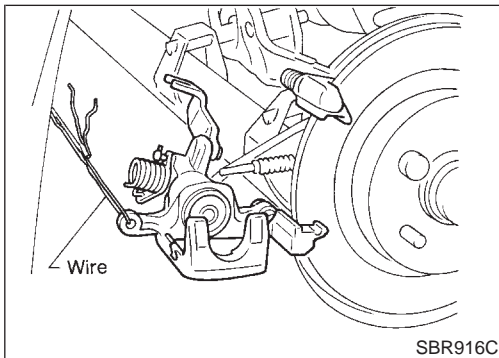

6. When installing new pads, push piston into cylinder body by gently turning piston clockwise, as shown. **Carefully monitor brake fluid level because brake fluid will return to reservoir when pushing back piston.**

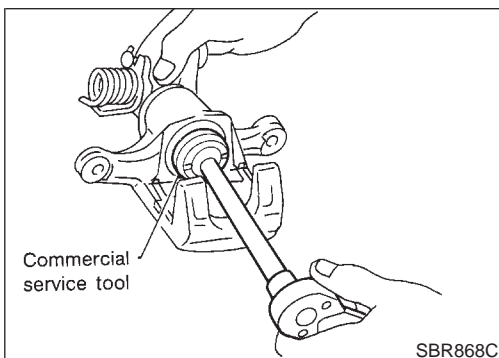

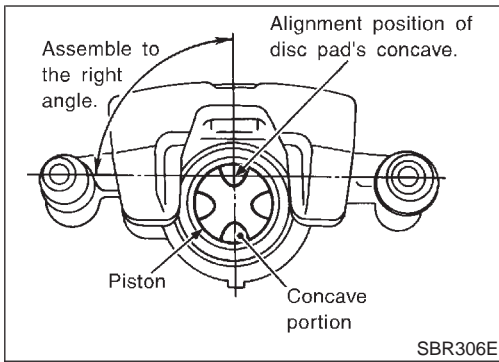

7. Adjust the piston to the right angle as shown in the figure.

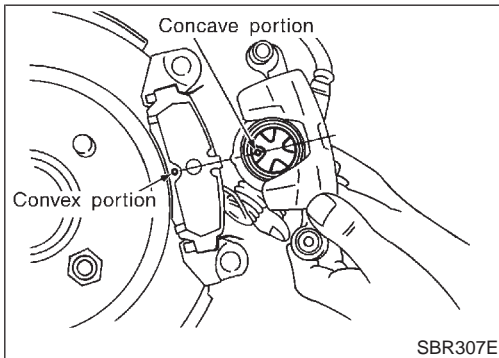

8. As shown in the figure, align the piston's concave portion to the pad's convex portion, then install the cylinder body to the torque member.

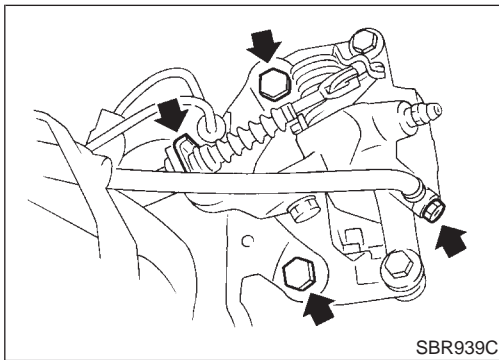

Removal

NFBR0039

WARNING:

Clean brake pads with a vacuum dust collector to minimize the hazard of airborne particles or other materials.

1. Remove brake cable mounting bolt and lock spring.
2. Release parking brake control lever, then disconnect cable from the caliper.
3. Remove torque member fixing bolts and connecting bolt.

It is not necessary to remove connecting bolt except for disassembly or replacement of caliper assembly. In this case, suspend caliper assembly with wire so as not to stretch brake hose.

GI
MA
EM
LC
EC
FE
CL
MT
AT
AX
SU
BR
ST
RS
BT
HA
SC
EL
IDX

REAR DISC BRAKE

Disassembly

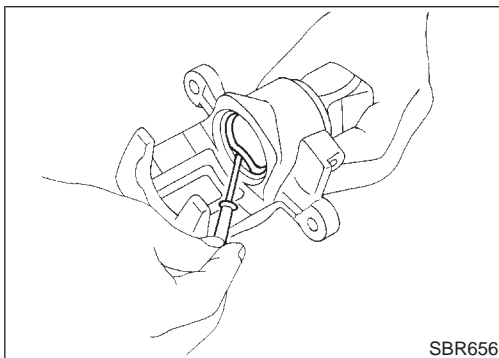
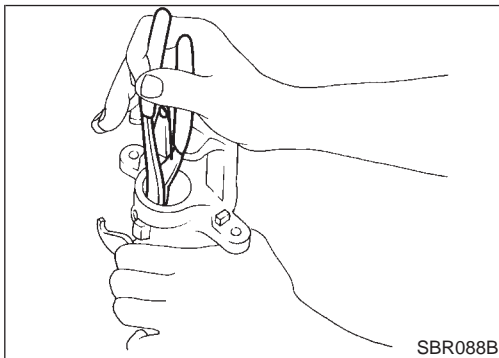
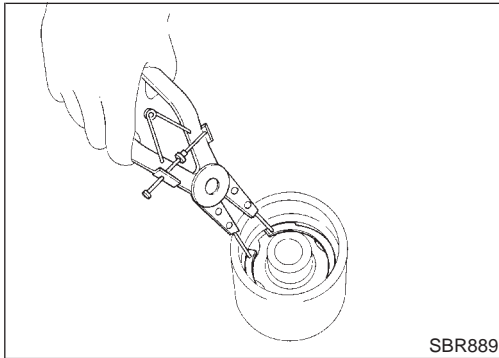
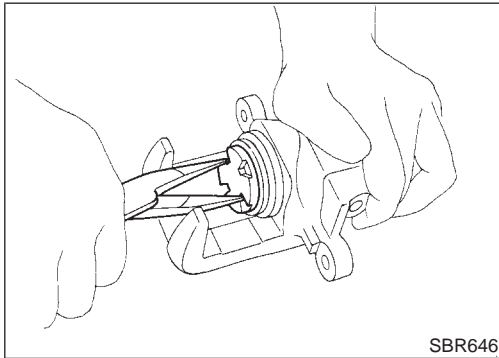
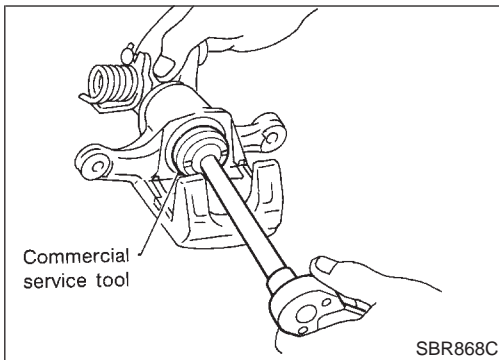

Disassembly

NFBR0040

1. Remove piston by turning it counterclockwise with suitable commercial service tool or long nose pliers.

2. Pry off ring A from piston with suitable pliers and remove adjusting nut.

3. Disassemble cylinder body.

- a. Pry off ring B with suitable pliers, then remove spring cover, spring and seat.

- b. Pry off ring C, then remove key plate, push rod and rod.

- c. Remove piston seal.

Be careful not to damage cylinder body.

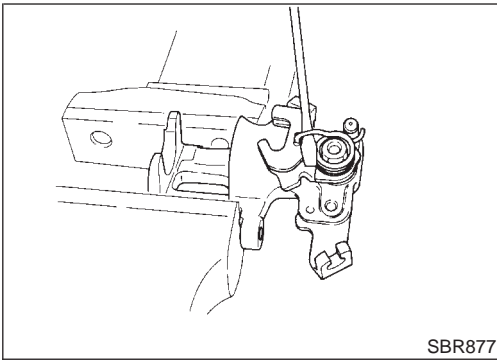

- Remove return spring, toggle lever and cable guide.

GI
MA
EM
LC

Inspection

CALIPER

NFBR0041

CAUTION:

NFBR0041S01

Use brake fluid to clean cylinder. Never use mineral oil.

Cylinder Body

NFBR0041S0101

- Check inside surface of cylinder for score, rust, wear, damage or presence of foreign materials. If any of the above conditions are observed, replace cylinder body.
- Minor damage from rust or foreign materials may be eliminated by polishing surface with a fine emery paper. Replace cylinder body if necessary.

EC
FE
CL
MT

Torque Member

NFBR0041S0102

Check for wear, cracks or other damage. Replace if necessary.

Piston

NFBR0041S0103

CAUTION:

Piston sliding surface is plated. Do not polish with emery paper even if rust or foreign matter is stuck to sliding surface.

Check piston for score, rust, wear, damage or presence of foreign materials.

Replace if any of the above conditions are observed.

AT
AX
SU

Pin and Pin Boot

NFBR0041S0104

Check for wear, cracks or other damage.

Replace if any of the above conditions are observed.

BR
ST

RS

BT

HA

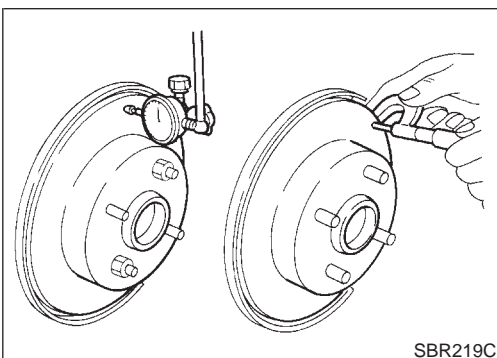

ROTOR

Rubbing Surface

NFBR0041S02

Check rotor for roughness, cracks or chips.

NFBR0041S0201

Runout

NFBR0041S0202

- Secure rotor to wheel hub with two nuts (M12 x 1.25).
- Check runout using a dial indicator.

EL
IDX

Make sure that axial end play is within the specifications before measuring. Refer to AX section ("REAR WHEEL BEARING", "On-vehicle Service").

REAR DISC BRAKE

Inspection (Cont'd)

3. Change relative positions of rotor and wheel hub so that runout is minimized.

Maximum runout:
0.07 mm (0.0028 in)

Thickness

Rotor repair limit:
Standard thickness
9 mm (0.35 in)
Minimum thickness
8 mm (0.315 in)
Thickness variation (At least 8 portions)
Maximum 0.02 mm (0.0008 in)

NFBR0041S0203

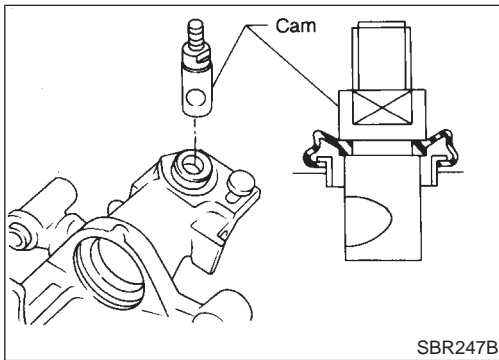

Assembly

1. Insert cam with depression facing towards open end of cylinder.

NFBR0042

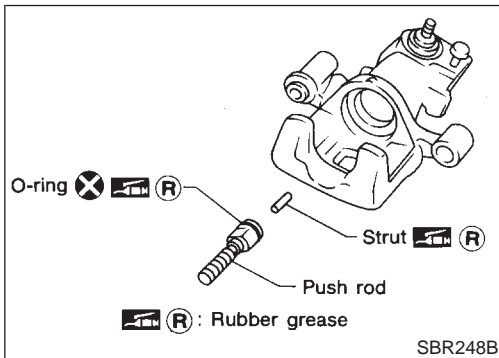

2. Generously apply rubber grease to strut and push rod to make insertion easy.

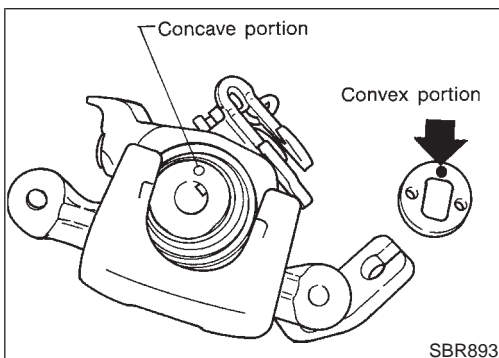

3. Fit push rod into square hole in key plate. Also match convex portion of key plate with concave portion of cylinder.

REAR DISC BRAKE

Assembly (Cont'd)

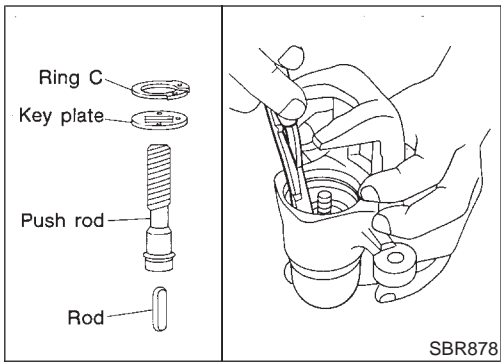

4. Install ring C with a suitable tool.

GI

MA

EM

LC

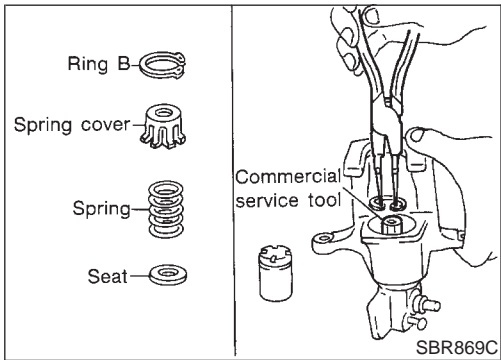

5. Install seat, spring, spring cover and ring B with suitable press and drift.

EC

FE

CL

MT

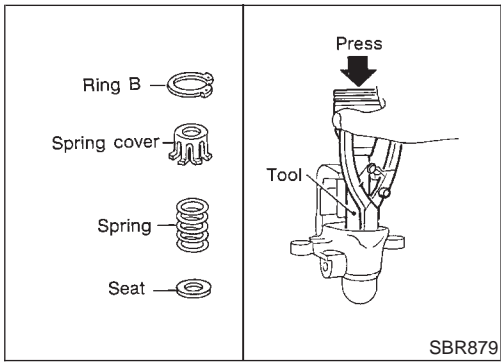

AT

AX

SU

BR

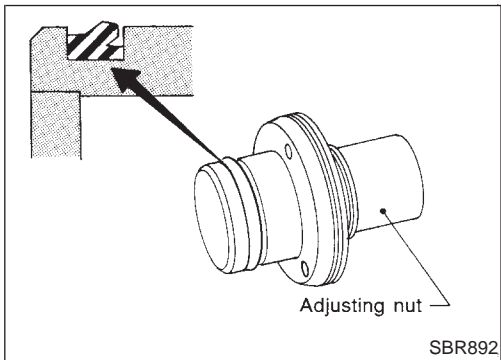

6. Install cup in the specified direction.

ST

RS

BT

HA

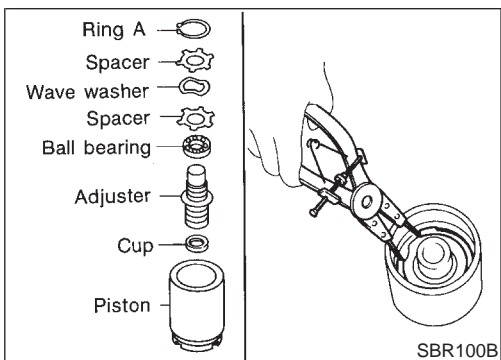

7. Install cup, adjuster, bearing, spacers, washers and ring A with a suitable tool.

SC

EL

IDX

REAR DISC BRAKE

Assembly (Cont'd)

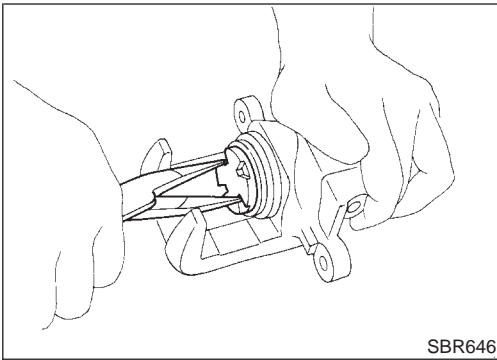

8. Insert piston seal into groove on cylinder body.
9. With piston boot fitted to piston, insert piston boot into groove on cylinder body and fit piston by turning it clockwise with long nose pliers, or suitable tool.

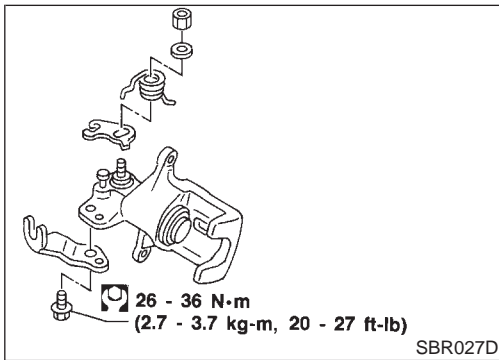
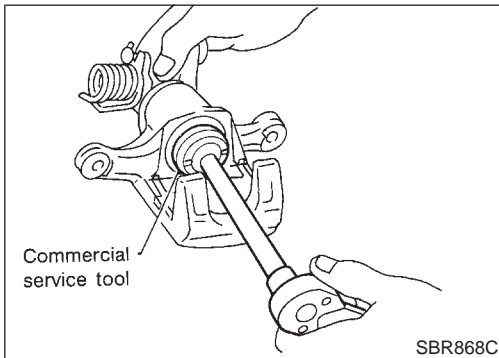

10. Fit toggle lever, return spring and cable guide.

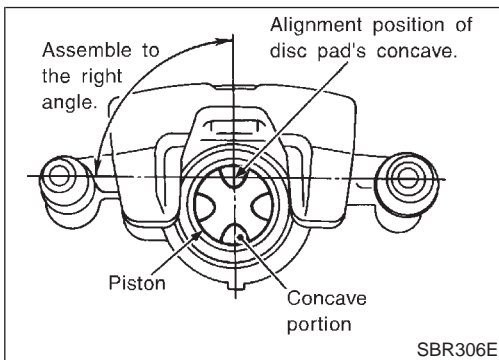

11. Adjust the piston to the right angle as shown in the figure.

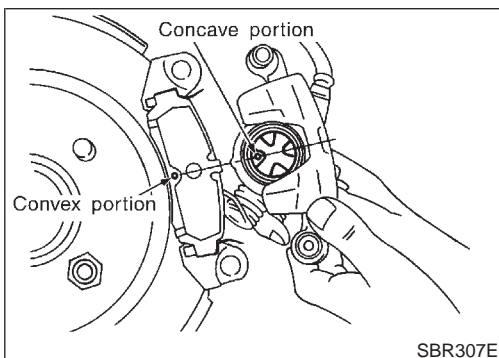

Installation

CAUTION:

- Refill with new brake fluid "DOT 3".
- Never reuse drained brake fluid.

1. Install caliper assembly.
- Align the piston's concave portion to the pad's convex portion, then install the cylinder body to the torque member.
2. Install brake hose to caliper securely.
3. Install all parts and secure all bolts.
4. Bleed air. Refer to "Bleeding Brake System", BR-9.

NFBR0043

Components

NFBR0044

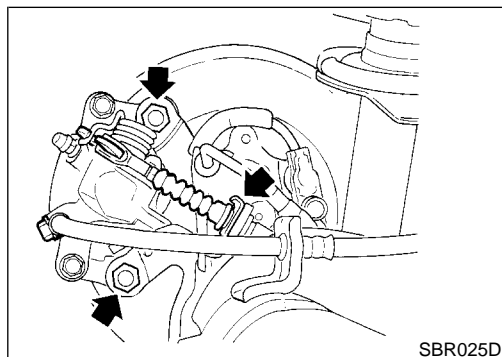
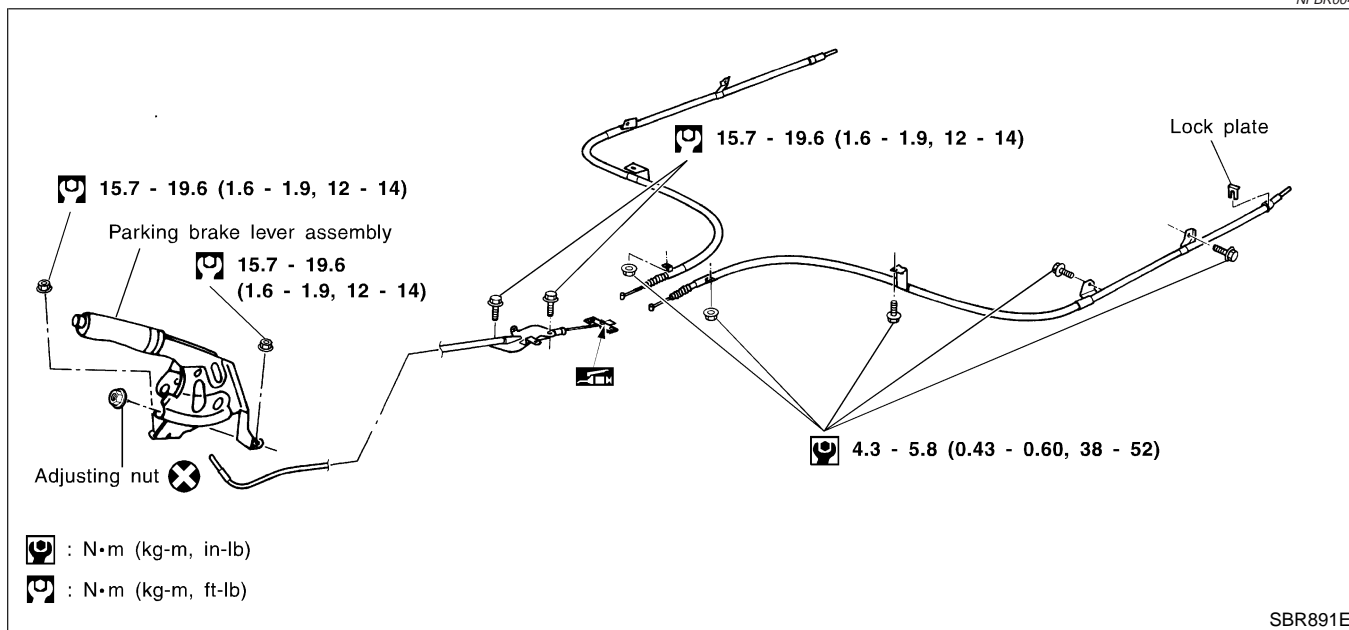

Removal and Installation

NFBR0045

1. To remove parking brake cable, first remove center console.
2. Disconnect warning switch connector.
3. Remove bolts and nuts, slacken off and remove adjusting nut.
4. Remove lock plate and disconnect cable.

Inspection

NFBR0046

1. Check control lever assembly for wear or other damage. Replace if necessary.
2. Check wires for discontinuity or deterioration. Replace if necessary.
3. Check warning lamp and switch. Replace if necessary.
4. Check parts at each connecting portion and, if found deformed or damaged, replace.

GI
MA
EM
LC
EC
FE
CL
MT
AT
AX
SU
BR
ST
RS
BT
HA
SC
EL
IDX

PARKING BRAKE CONTROL (CENTER LEVER TYPE)

Adjustment

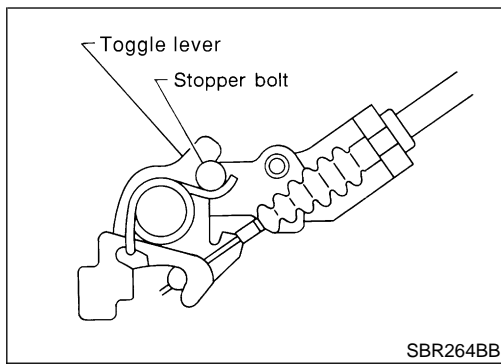

Adjustment

=NFBR0047

Pay attention to the following points after adjustment.

- 1) There is no drag when control lever is being released.
- 2) Be sure that toggle lever returns to stopper when parking brake lever is released.
1. Loosen parking brake cable.
2. Depress brake pedal fully more than five times.
3. Operate control lever 10 times or more with a full stroke [203.5 mm (8.01 in)].
4. Adjust control lever or pedal by turning adjusting nut.
5. Pull control lever with specified amount of force. Check lever stroke and ensure smooth operation.

Number of notches:

10 - 11 [196 N (20 kg, 44 lb)]

6. Bend warning lamp switch plate. Warning lamp should come on when lever is pulled "A" notches. It should go off when the lever is fully released.

Number of "A" notches: 1

Components

NFBR0128

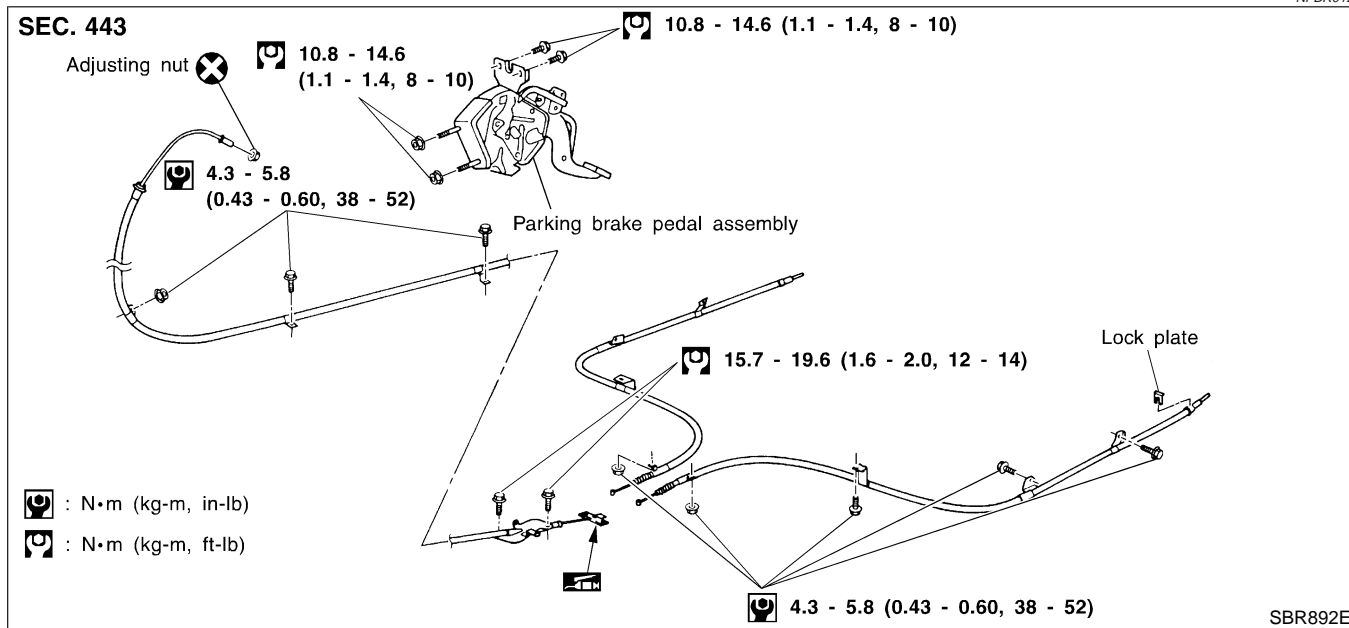

GI

MA

EM

LC

EC

FE

CL

MT

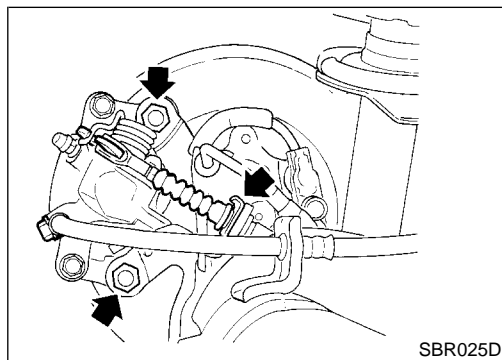

Removal and Installation

NFBR0129

1. To remove parking brake cable, first remove center console.
2. To remove parking brake pedal, remove lower instrument panel on driver side.
3. Disconnect warning switch connector.
4. Remove bolts and nuts, slacken off and remove adjusting nut.
5. Remove lock plate and disconnect cable.

AT

AX

SU

BR

Inspection

NFBR0130

1. Check parking brake pedal assembly for wear or other damage. Replace if necessary.
2. Check wires for discontinuity or deterioration. Replace if necessary.
3. Check warning lamp and switch. Replace if necessary.
4. Check parts at each connecting portion and, if found deformed or damaged, replace.

ST

RS

BT

HA

SC

EL

IDX

PARKING BRAKE CONTROL (FOOT LEVER TYPE)

Adjustment

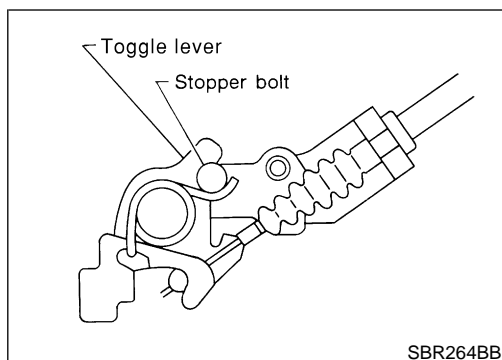

Adjustment

=NFBR0131

Pay attention to the following points after adjustment.

- 1) There is no drag when parking brake pedal is being released.
- 2) Be sure that toggle lever returns to stopper when parking brake pedal is released.
1. Loosen parking brake cable.
2. Depress brake pedal fully more than five times.
3. Operate parking brake pedal 10 times or more with a full stroke [203.5 mm (8.01 in)].
4. Adjust parking brake pedal by turning adjusting nut.
5. Depress pedal with specified amount of force. Check pedal stroke and ensure smooth operation.

Number of notches:

4 - 5 [196 N (20 kg, 44 lb)]

6. Bend warning lamp switch plate. Warning lamp should come on when pedal is depressed "A" notches. It should go off when the lever is fully released.

Number of "A" notches: 1

Purpose

The ABS consists of electronic and hydraulic components. It allows for control of braking force so that locking of the wheels can be avoided.

NFBR0100

The ABS:

- 1) Ensures proper tracking performance through steering wheel operation.
- 2) Enables obstacles to be avoided through steering wheel operation.
- 3) Ensures vehicle stability by preventing flat spins.

ABS (Anti-Lock Brake System) Operation

NFBR0101

- When the vehicle speed is less than 10 km/h (6 MPH) this system does not work.
- The Anti-Lock Brake System (ABS) has self-test capabilities. The system turns on the ABS warning lamp for 1 second after turning the ignition switch ON. The system performs another test the first time the vehicle reaches 6 km/h (4 MPH). A mechanical noise may be heard as the ABS performs a self-test. This is a normal part of the self-test feature. If a malfunction is found during this check, the ABS warning lamp will come on.
- During ABS operation, a mechanical noise may be heard. This is a normal condition.

ABS Hydraulic Circuit

NFBR0102

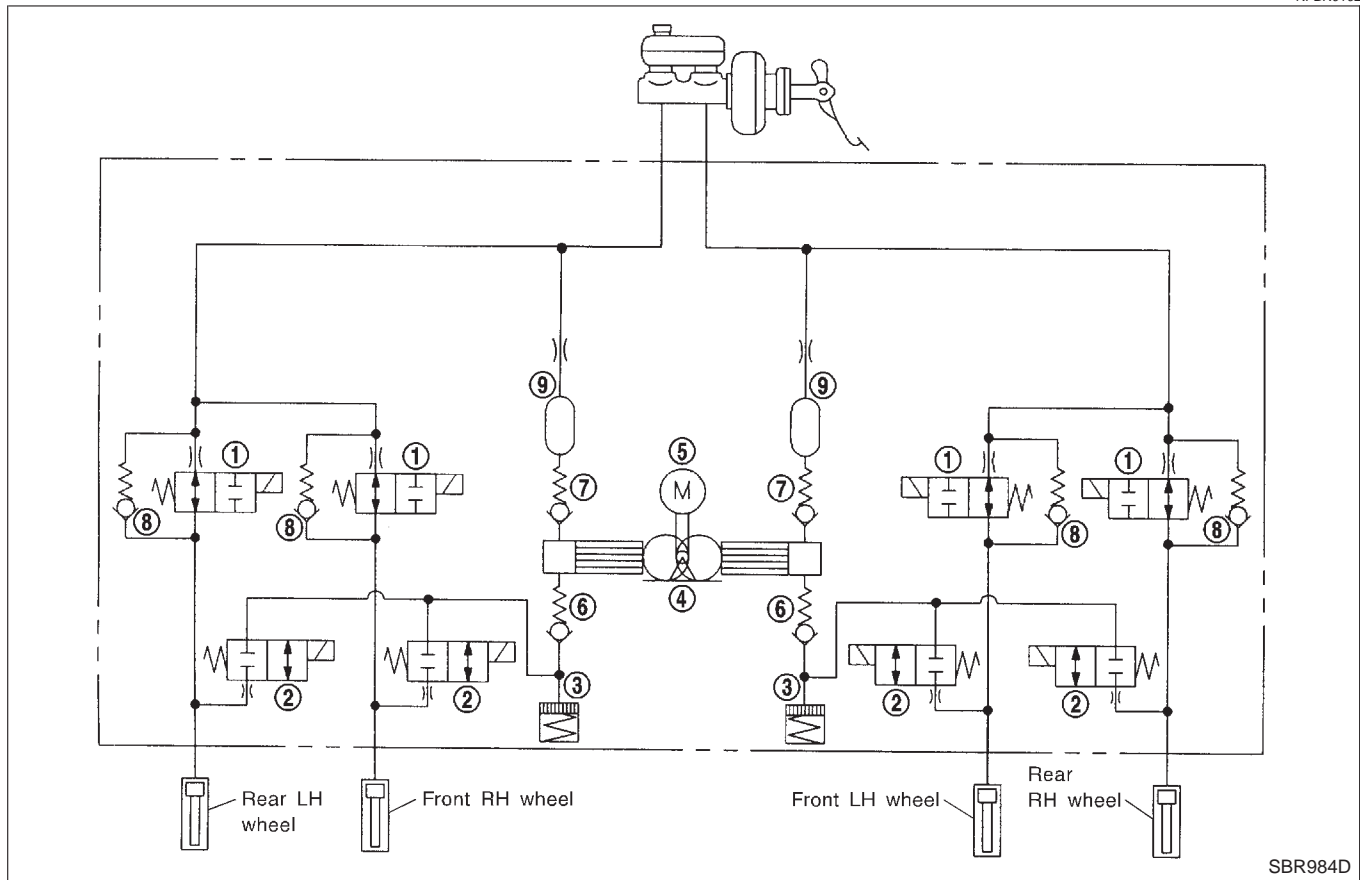

- | | | |
|--------------------------|----------------|-----------------------|
| 1. Inlet solenoid valve | 4. Pump | 7. Outlet valve |
| 2. Outlet solenoid valve | 5. Motor | 8. Bypass check valve |
| 3. Reservoir | 6. Inlet valve | 9. Damper |

GI
MA
EM
LC
EC
FE
CL
MT
AT
AX
SU
BR
ST
RS
BT
HA
SC
EL
IDX

System Components

NFBR0103

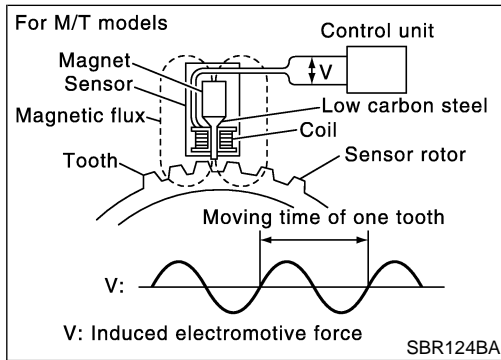
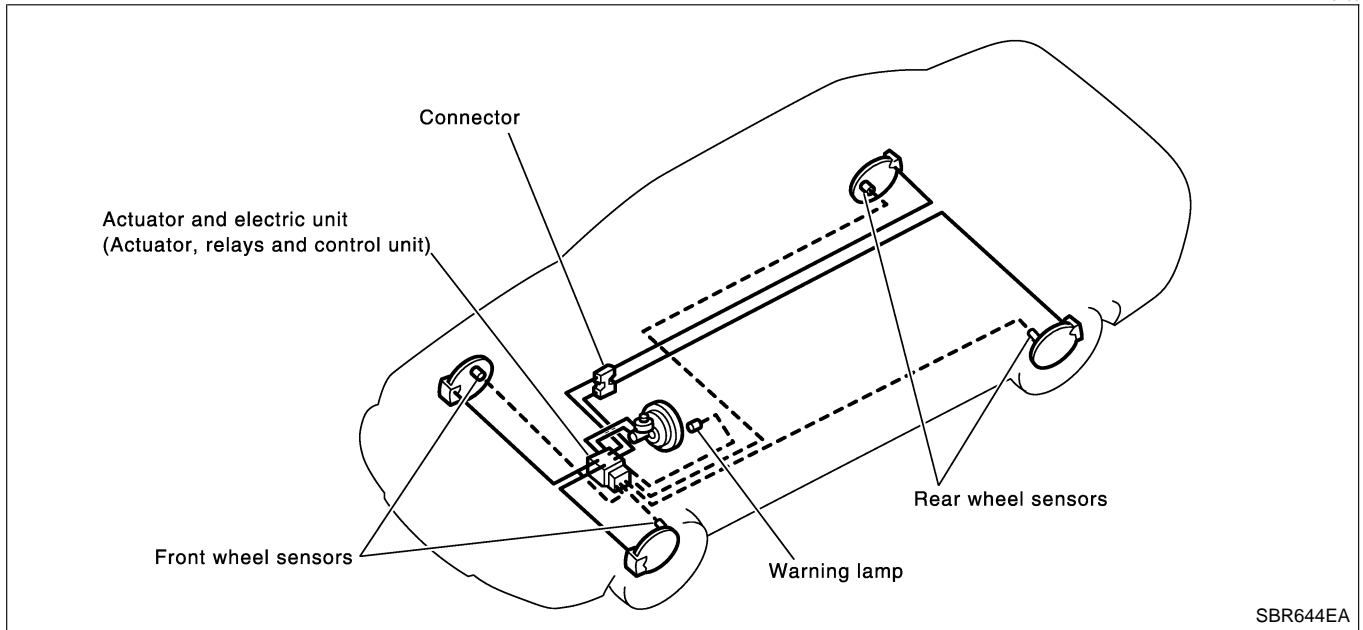

System Description

NFBR0104

SENSOR

NFBR0104S01

For M/T models:

The sensor unit consists of a gear-shaped sensor rotor and a sensor element. The element contains a bar magnet around which a coil is wound. The sensor is installed on the back side of the brake rotor. Sine-wave current is generated by the sensor as the wheel rotates. The frequency and voltage increase(s) as the rotating speed increases.

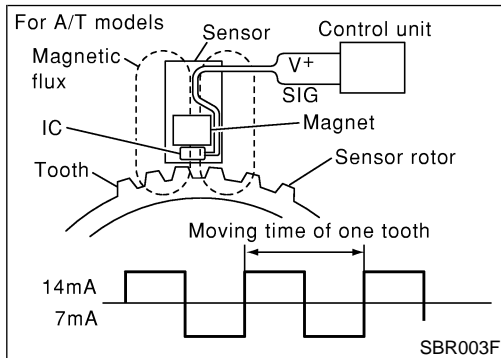

For A/T models:

The front sensor units consist of a gear-shaped sensor rotor and a sensor element. The element contains a magnet and IC. The front wheel sensors are installed on the front of the wheel knuckles. As the wheel rotates, the sensor generates a square-wave signal. The frequency increase as the wheel speed increase.

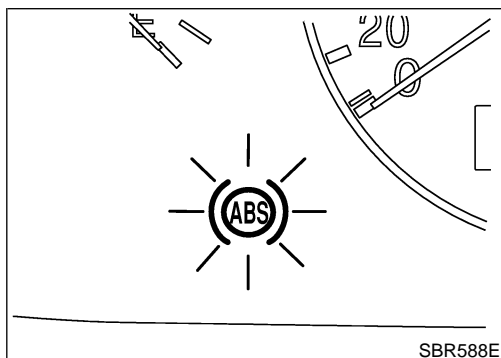

CONTROL UNIT

NFBR0104S02

The control unit computes the wheel rotating speed by the signal current sent from the sensor. Then it supplies a DC current to the actuator solenoid valve. It also controls ON-OFF operation of the valve relay and motor relay. If any electrical malfunction should be detected in the system, the control unit causes the warning lamp to light up. In this condition, the ABS will be deactivated by the control unit, and the vehicle's brake system reverts to normal operation.

DESCRIPTION

ABS

System Description (Cont'd)

NFBR0104S03

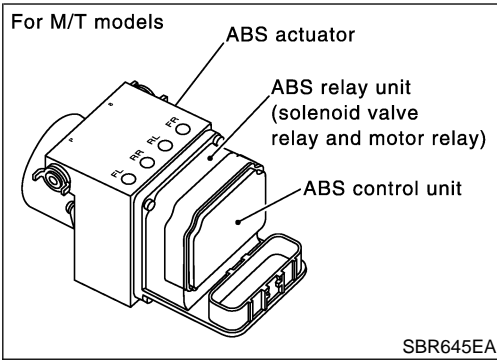

ABS ACTUATOR AND ELECTRIC UNIT

The ABS actuator and electric unit contains:

- An electric motor and pump
- Two relays
- Eight solenoid valves, each inlet and outlet for
 - LH front
 - RH front
 - LH rear
 - RH rear
- ABS control unit

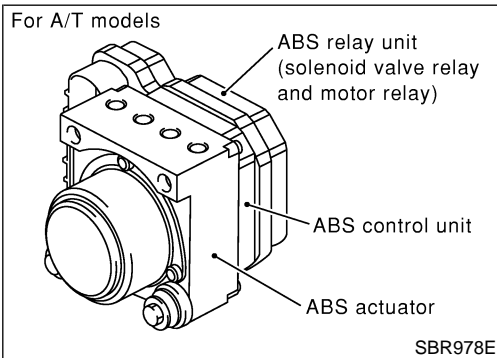

This components controls the hydraulic circuit and increases, holds or decreases hydraulic pressure to all or individual wheels. The ABS actuator and electric unit are not disassemble.

GI
MA
EM
LC
EC
FE
CL
MT

AT
AX
SU

BR

ABS Actuator Operation

NFBR0104S0301

		Inlet solenoid valve	Outlet solenoid valve	
Normal brake operation		OFF (Open)	OFF (Closed)	Master cylinder brake fluid pressure is directly transmitted to caliper via the inlet solenoid valve.
ABS operation	Pressure hold	ON (Closed)	OFF (Closed)	Hydraulic circuit is shut off to hold the caliper brake fluid pressure.
	Pressure decrease	ON (Closed)	ON (Open)	Caliper brake fluid is sent to reservoir via the outlet solenoid valve. Then it is pushed up to the master cylinder by pump.
	Pressure increase	OFF (Open)	OFF (Closed)	Master cylinder brake fluid pressure is transmitted to caliper.

ST
RS
BT
HA
SC
EL
IDX

Component Parts and Harness Connector Location

NFBR0105

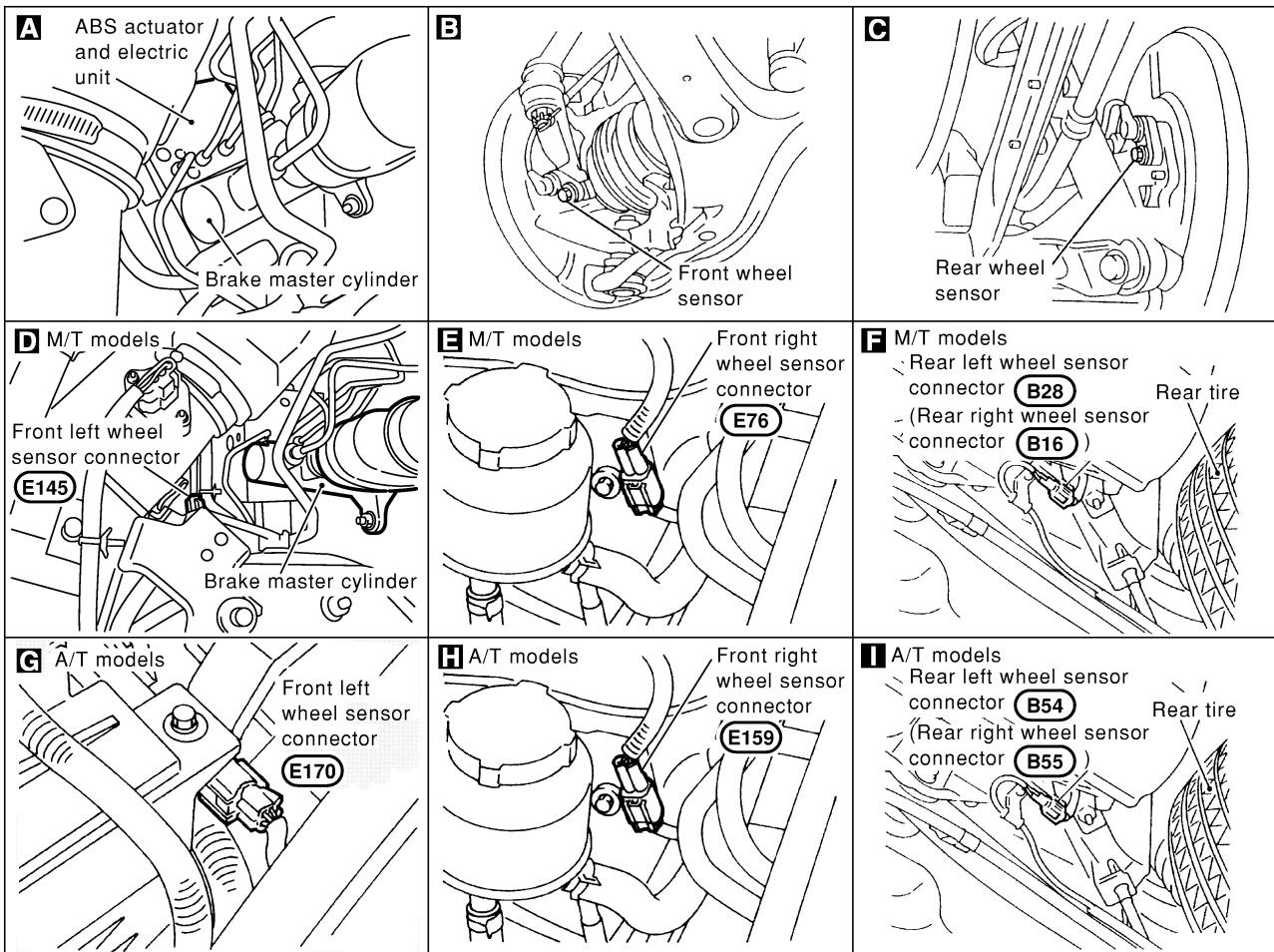
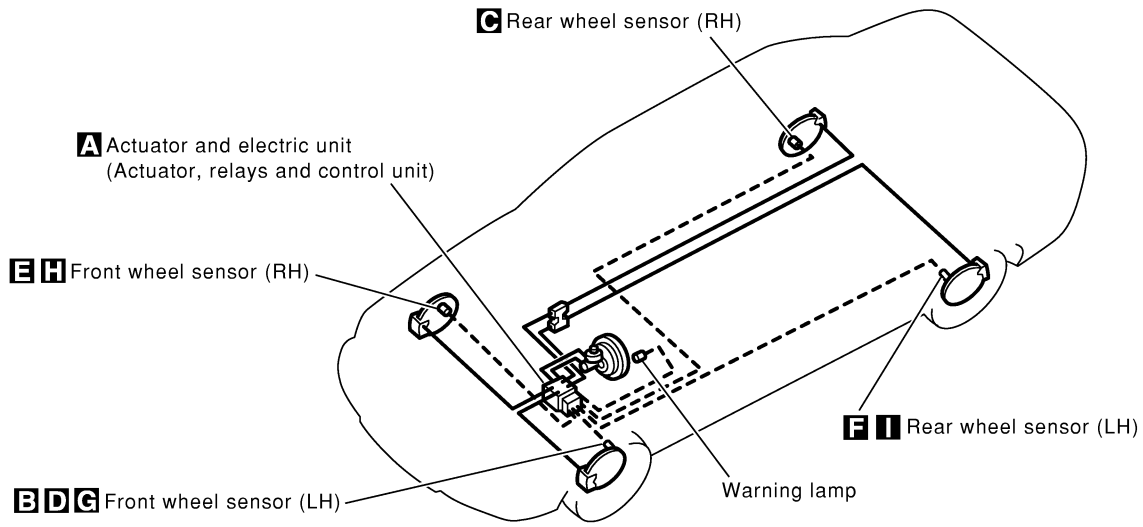

Schematic

NFBR0106

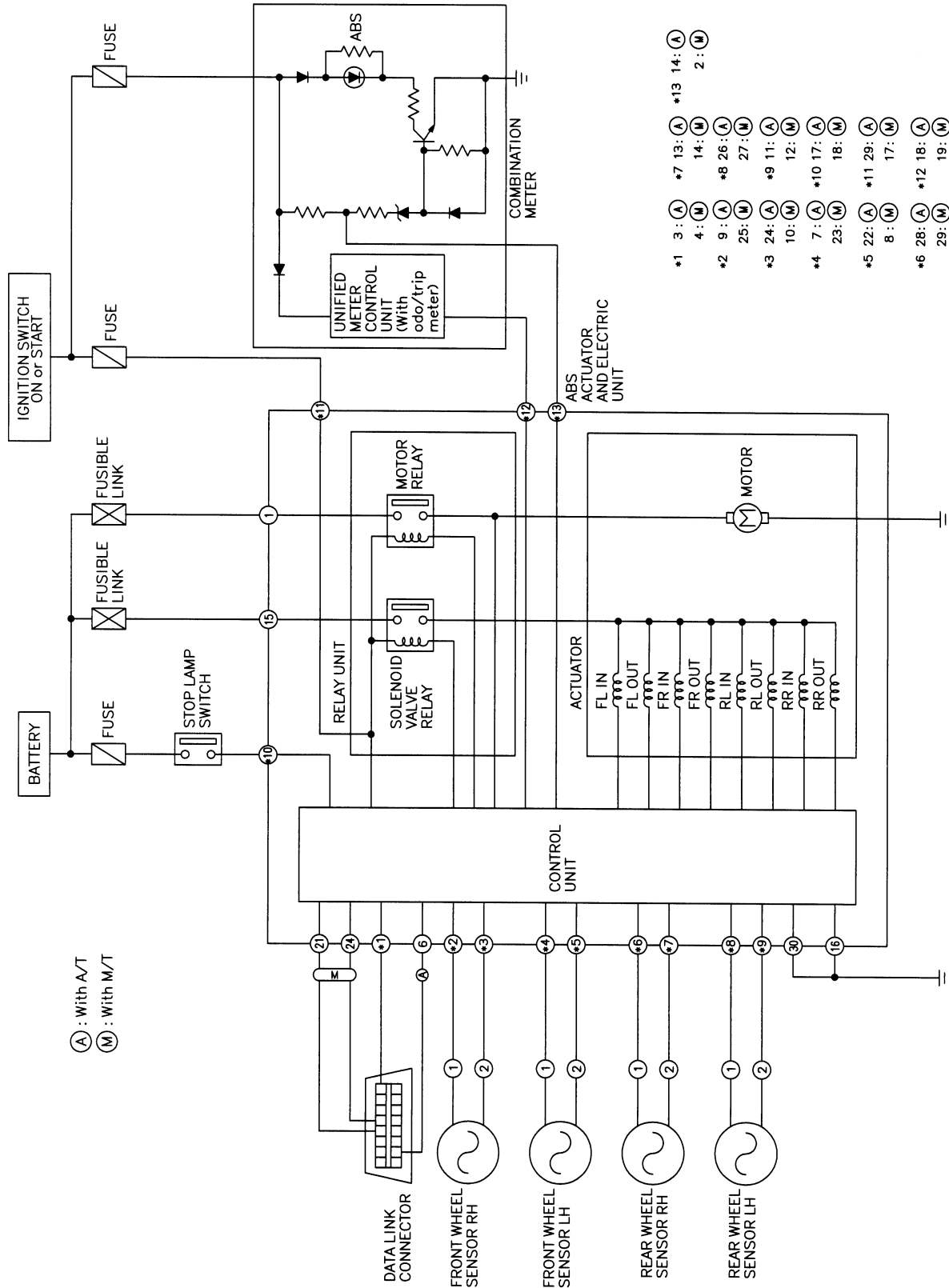

GI
MA
EM
LC
EC
FE
CL
MT
AT
AX
SU
BR
ST
RS
BT
HA
SC
EL
IDX

Wiring Diagram — ABS —

NFBR0107

BR-ABS-01

- (A) : WITH A/T
- (M) : WITH M/T
- *1 14 : (A)
- 2 : (M)
- *2 18 : (A)
- 19 : (M)
- *3 17 : (A)
- 18 : (M)

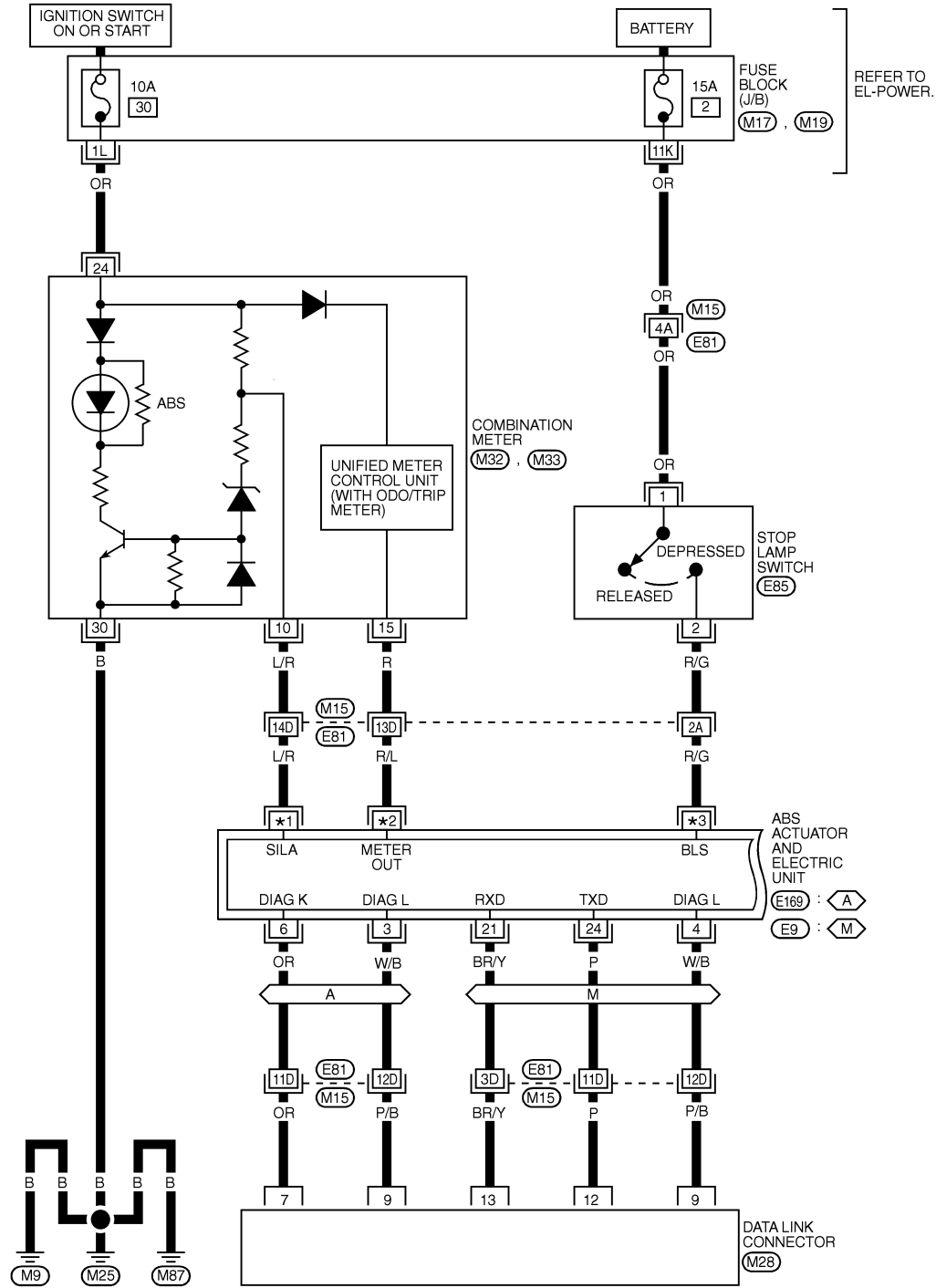

REFER TO EL-POWER.

ABS ACTUATOR AND ELECTRIC UNIT
 (E169) : (A)
 (E9) : (M)

DATA LINK CONNECTOR
 (M28)

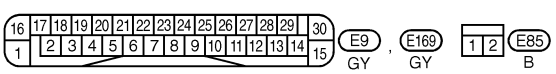
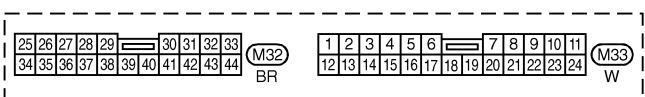
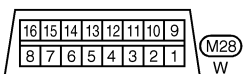

REFER TO THE FOLLOWING.
 (M15) -SUPER
 MULTIPLE JUNCTION (SMJ)
 (M17), (M19) -FUSE BLOCK-JUNCTION BOX (J/B)

DESCRIPTION

ABS

Wiring Diagram — ABS — (Cont'd)

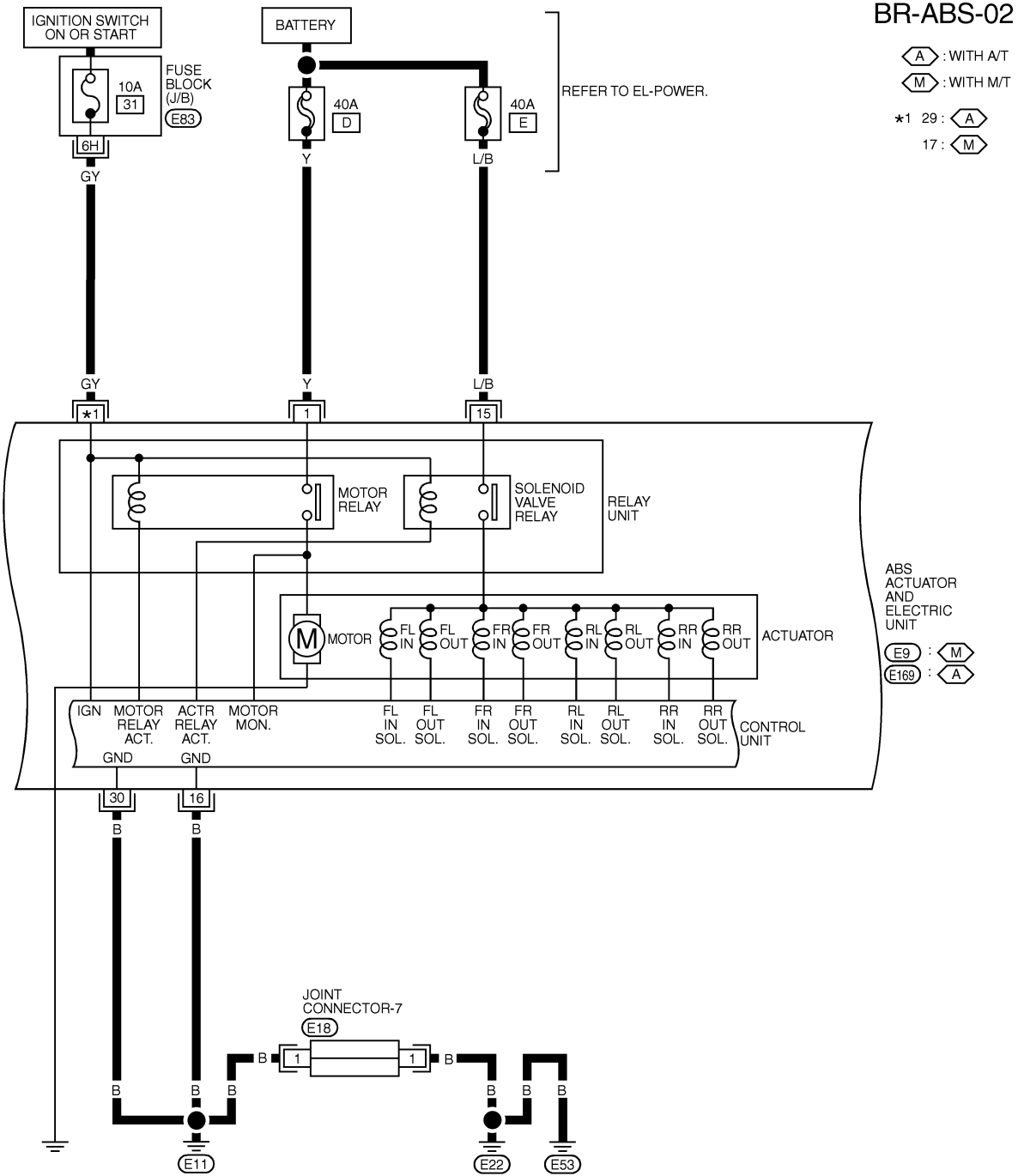

GI
MA
EM
LC
EC
FE
CL
MT
AT
AX
SU
BR
ST
RS
BT
HA
SC
EL
IDX

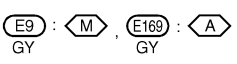
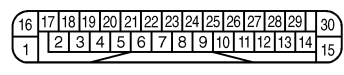

REFER TO THE FOLLOWING.
(E83) - FUSE BLOCK-JUNCTION BOX (J/B)

MBR511A

BR-ABS-03

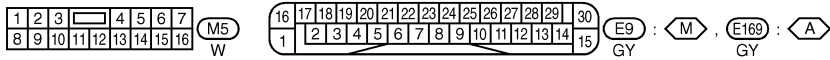
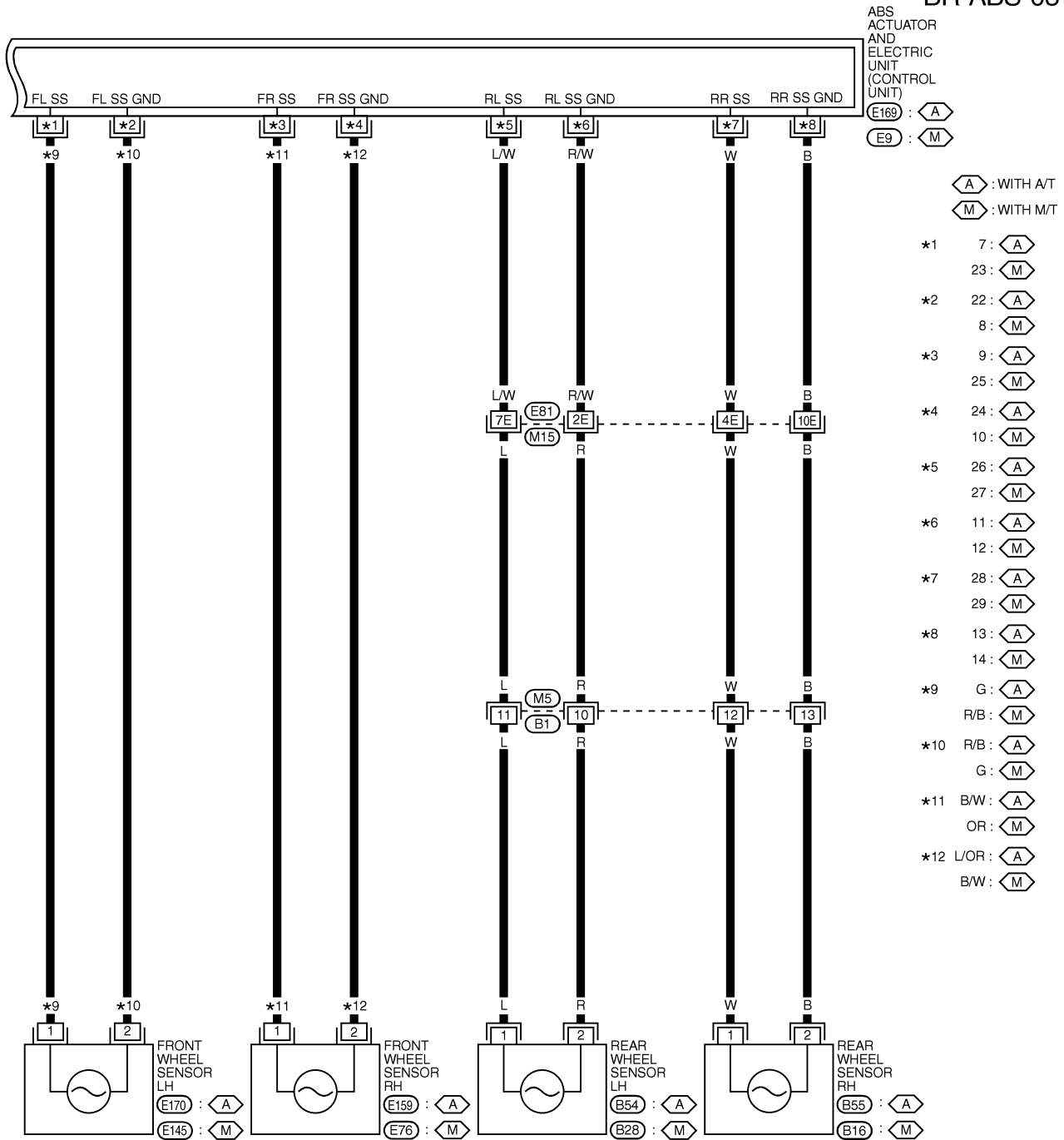

REFER TO THE FOLLOWING.
(M15) -SUPER
MULTIPLE JUNCTION (SMJ)

DESCRIPTION

ABS

Wiring Diagram — ABS — (Cont'd)

For M/T models

ABS ACTUATOR AND ELECTRIC UNIT TERMINALS AND REFERENCE VALUE (MEASURED BETWEEN EACH TERMINAL AND 16 OR 30).

TERMINAL	WIRE COLOR	ITEM	CONDITION	DATA (DC)
1	Y	POWER SOURCE	—	BATTERY VOLTAGE
2	L/R	ABS WARNING LAMP IN COMBINATION METER	WHEN ABS WARNING LAMP IS ACTIVE	BATTERY VOLTAGE
			WHEN ABS WARNING LAMP IS NOT ACTIVE	APPROX. 0V
4	P/B	DATA LINK CONNECTOR	—	—
8	G	FRONT WHEEL SENSOR LH	WHEN VEHICLE CRUISES AT 30 KM/H (19 MPH)	PULSE FRONT: APPROX. 190 HZ REAR: APPROX. 190 HZ
10	B/P	FRONT WHEEL SENSOR RH		
12	B/P	REAR WHEEL SENSOR LH		
14	P	REAR WHEEL SENSOR RH		
23	R	FRONT WHEEL SENSOR LH		
25	OR	FRONT WHEEL SENSOR RH		
27	OR	REAR WHEEL SENSOR LH		
29	L	REAR WHEEL SENSOR RH		
15	BR	POWER SOURCE	—	BATTERY VOLTAGE
16	B	GROUND	—	—
17	GY	POWER SOURCE	IGN ON IGN OFF	BATTERY VOLTAGE APPROX. 0V
18	R/G	STOP LAMP SWITCH	WHEN BRAKE PEDAL DEPRESSED WHEN BRAKE PEDAL RELEASED	BATTERY VOLTAGE APPROX. 0V
21	BR/Y	DATA LINK CONNECTOR	—	—
24	P	DATA LINK CONNECTOR	—	—
30	B	GROUND	—	—

SBR930E

For A/T models

ABS ACTUATOR AND ELECTRIC UNIT TERMINALS AND REFERENCE VALUE (MEASURED BETWEEN EACH TERMINAL AND 16 OR 30).

TERMINAL	WIRE COLOR	ITEM	CONDITION	DATA (DC)
1	Y	POWER SOURCE	—	BATTERY VOLTAGE
3	W/B	DATA LINK CONNECTOR	—	—
14	L/R	ABS WARNING LAMP IN COMBINATION METER	WHEN ABS WARNING LAMP IS ACTIVE	BATTERY VOLTAGE
			WHEN ABS WARNING LAMP IS NOT ACTIVE	APPROX. 0V
15	BR	POWER SOURCE	—	BATTERY VOLTAGE
16	B	GROUND	—	—
29	GY	POWER SOURCE	IGN ON IGN OFF	BATTERY VOLTAGE APPROX. 0V
17	R/G	STOP LAMP SWITCH	WHEN BRAKE PEDAL DEPRESSED WHEN BRAKE PEDAL RELEASED	BATTERY VOLTAGE APPROX. 0V
6	OR	DATA LINK CONNECTOR	—	—
30	B	GROUND	—	—

SBR044F

CONSULT-II

NFBR0207

CONSULT-II APPLICATION TO ABS

NFBR0207S01

ITEM	SELF-DIAGNOSTIC RESULTS	DATA MONITOR	ACTIVE TEST
Front right wheel sensor	X	X	—
Front left wheel sensor	X	X	—
Rear right wheel sensor	X	X	—
Rear left wheel sensor	X	X	—
Stop lamp switch	—	X	—
Front right inlet solenoid valve	X	X	X
Front right outlet solenoid valve	X	X	X
Front left inlet solenoid valve	X	X	X
Front left outlet solenoid valve	X	X	X
Rear right inlet solenoid valve	X	X	X
Rear right outlet solenoid valve	X	X	X
Rear left inlet solenoid valve	X	X	X
Rear left outlet solenoid valve	X	X	X
Actuator solenoid valve relay	—	X	—
Actuator motor relay (ABS MOTOR is shown on the ACTIVE TEST screen.)	X	X	X
ABS warning lamp	—	X	—
Battery voltage	X	X	—
Control unit	X	—	—
EBD operation (For A/T models)	—	X	—
ABS operation (For A/T models)	—	X	—
EBD fail safe (For A/T models)	—	X	—
ABS fail safe (For A/T models)	—	X	—

X: Applicable

—: Not applicable

ECU (ABS CONTROL UNIT) PART NUMBER MODE

NFBR0207S02

Ignore the ECU part number displayed in the ECU PART NUMBER MODE. Refer to parts catalog to order the ABS actuator and electric unit.

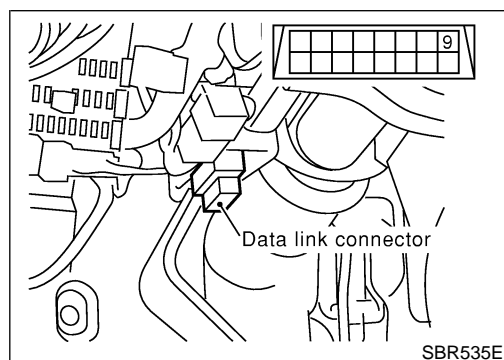

CONSULT-II Inspection Procedure SELF-DIAGNOSIS PROCEDURE

NFBR0110

NFBR0110S01

1. Turn ignition switch OFF.
2. Connect CONSULT-II to Data Link Connector.
3. Start engine.
4. Drive vehicle over 30 km/h (19 MPH) for at least one minute.

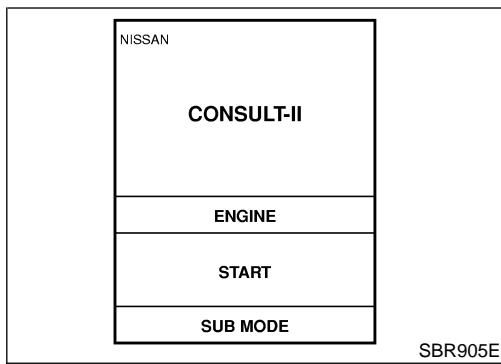

5. Stop vehicle with engine running and touch "START" on CONSULT-II screen.

GI

MA

EM

LC

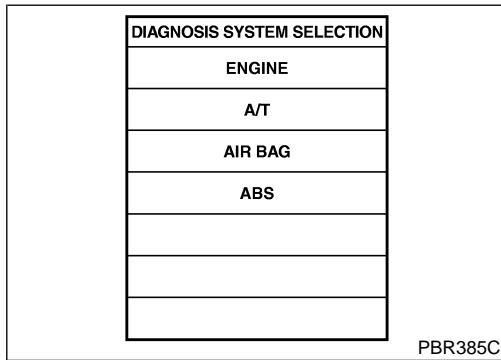

6. Touch "ABS".

EC

FE

CL

MT

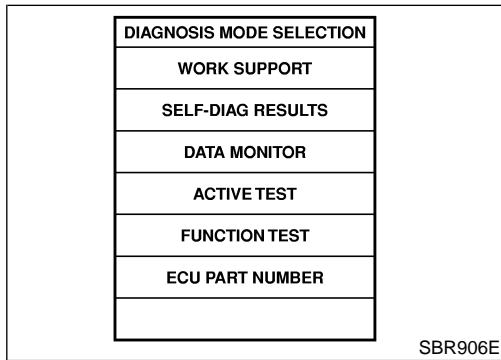

7. Touch "SELF-DIAG RESULTS".

- The screen shows the detected malfunction and how many times the ignition switch has been turned since the malfunction.

AT

8. Make the necessary repairs following the diagnostic procedures.

AX

SU

BR

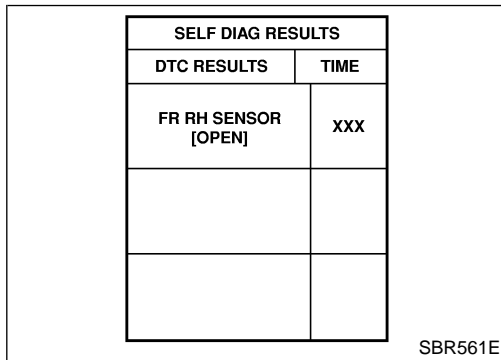

9. After the malfunctions are repaired, erase the self-diagnostic results stored in the control unit by touching "ERASE".

ST

10. Check ABS warning lamp for deactivation after driving vehicle over 30 km/h (19 MPH) for at least one minute.

RS

NOTE:

"SELF-DIAG RESULTS" screen shows the detected malfunction and how many times the ignition switch has been turned since the malfunction.

BT

HA

SC

EL

IDX

ON BOARD DIAGNOSTIC SYSTEM DESCRIPTION

ABS

CONSULT-II Inspection Procedure (Cont'd)

SELF-DIAGNOSTIC RESULTS MODE (FOR M/T MODELS)

=NFBR0110S02

Diagnostic item	Diagnostic item is detected when ...	Reference Page
FR RH SENSOR [OPEN]*1	<ul style="list-style-type: none"> ● Circuit for front right wheel sensor is open. (An abnormally high input voltage is entered.) 	BR-61
FR LH SENSOR [OPEN]*1	<ul style="list-style-type: none"> ● Circuit for front left wheel sensor is open. (An abnormally high input voltage is entered.) 	BR-61
RR RH SENSOR [OPEN]*1	<ul style="list-style-type: none"> ● Circuit for rear right sensor is open. (An abnormally high input voltage is entered.) 	BR-61
RR LH SENSOR [OPEN]*1	<ul style="list-style-type: none"> ● Circuit for rear left sensor is open. (An abnormally high input voltage is entered.) 	BR-61
FR RH SENSOR [SHORT]*1	<ul style="list-style-type: none"> ● Circuit for front right wheel sensor is shorted. (An abnormally low input voltage is entered.) 	BR-61
FR LH SENSOR [SHORT]*1	<ul style="list-style-type: none"> ● Circuit for front left wheel sensor is shorted. (An abnormally low input voltage is entered.) 	BR-61
RR RH SENSOR [SHORT]*1	<ul style="list-style-type: none"> ● Circuit for rear right sensor is shorted. (An abnormally low input voltage is entered.) 	BR-61
RR LH SENSOR [SHORT]*1	<ul style="list-style-type: none"> ● Circuit for rear left sensor is shorted. (An abnormally low input voltage is entered.) 	BR-61
FR RH IN ABS SOL [OPEN]	<ul style="list-style-type: none"> ● Circuit for front right inlet solenoid valve is open. (An abnormally low output voltage is entered.) 	BR-66
FR LH IN ABS SOL [OPEN]	<ul style="list-style-type: none"> ● Circuit for front left inlet solenoid valve is open. (An abnormally low output voltage is entered.) 	BR-66
RR RH IN ABS SOL [OPEN]	<ul style="list-style-type: none"> ● Circuit for rear right inlet solenoid valve is open. (An abnormally low output voltage is entered.) 	BR-66
RR LH IN ABS SOL [OPEN]	<ul style="list-style-type: none"> ● Circuit for rear left inlet solenoid valve is open. (An abnormally low output voltage is entered.) 	BR-66
FR RH IN ABS SOL [SHORT]	<ul style="list-style-type: none"> ● Circuit for front right inlet solenoid valve is shorted. (An abnormally high output voltage is entered.) 	BR-66
FR LH IN ABS SOL [SHORT]	<ul style="list-style-type: none"> ● Circuit for front left inlet solenoid valve is shorted. (An abnormally high output voltage is entered.) 	BR-66
RR RH IN ABS SOL [SHORT]	<ul style="list-style-type: none"> ● Circuit for rear right inlet solenoid valve is shorted. (An abnormally high output voltage is entered.) 	BR-66
RR LH IN ABS SOL [SHORT]	<ul style="list-style-type: none"> ● Circuit for rear left inlet solenoid valve is shorted. (An abnormally high output voltage is entered.) 	BR-66
FR RH OUT ABS SOL [OPEN]	<ul style="list-style-type: none"> ● Circuit for front right outlet solenoid valve is open. (An abnormally low output voltage is entered.) 	BR-66
FR LH OUT ABS SOL [OPEN]	<ul style="list-style-type: none"> ● Circuit for front left outlet solenoid valve is open. (An abnormally low output voltage is entered.) 	BR-66
RR RH OUT ABS SOL [OPEN]	<ul style="list-style-type: none"> ● Circuit for rear right outlet solenoid valve is open. (An abnormally low output voltage is entered.) 	BR-66
RR LH OUT ABS SOL [OPEN]	<ul style="list-style-type: none"> ● Circuit for rear left outlet solenoid valve is open. (An abnormally low output voltage is entered.) 	BR-66
FR RH OUT ABS SOL [SHORT]	<ul style="list-style-type: none"> ● Circuit for front right outlet solenoid valve is shorted. (An abnormally high output voltage is entered.) 	BR-66
FR LH OUT ABS SOL [SHORT]	<ul style="list-style-type: none"> ● Circuit for front left outlet solenoid valve is shorted. (An abnormally high output voltage is entered.) 	BR-66

Diagnostic item	Diagnostic item is detected when ...	Reference Page
RR RH OUT ABS SOL [SHORT]	<ul style="list-style-type: none"> ● Circuit for rear right outlet solenoid valve is shorted. (An abnormally high output voltage is entered.) 	BR-66
RR LH OUT ABS SOL [SHORT]	<ul style="list-style-type: none"> ● Circuit for rear left outlet solenoid valve is shorted. (An abnormally high output voltage is entered.) 	BR-66
ABS ACTUATOR RELAY [ABNORMAL]	<ul style="list-style-type: none"> ● Actuator solenoid valve relay is ON, even control unit sends off signal. ● Actuator solenoid valve relay is OFF, even control unit sends on signal. 	BR-66
ABS MOTOR RELAY [ABNORMAL]	<ul style="list-style-type: none"> ● Circuit for actuator motor is open or shorted. ● Actuator motor relay is stuck. 	BR-70
BATTERY VOLT [ABNORMAL]	<ul style="list-style-type: none"> ● Power source voltage supplied to ABS control unit is abnormally low. 	BR-73
CONTROL UNIT*2	<ul style="list-style-type: none"> ● Function of calculation in ABS control unit has failed. 	BR-75

*1: Be sure to confirm the ABS warning lamp illuminates when the ignition switch is turned ON after repairing the shorted sensor circuit, but the lamp goes out when driving the vehicle over 30 km/h (19 MPH) for one minute in accordance with SELF-DIAGNOSIS PROCEDURE.

*2: When "CONTROL UNIT 5" is displayed, check to see if the ABS warning lamp is burned out, and check the circuit between the ABS warning lamp and ABS actuator/electric unit for open or short. Then check the ABS actuator/electric unit and circuit. When "CONTROL UNIT XX (except "CONTROL UNIT 5")" is displayed, "CONTROL UNIT DIAGNOSTIC PROCEDURE" (BR-75).

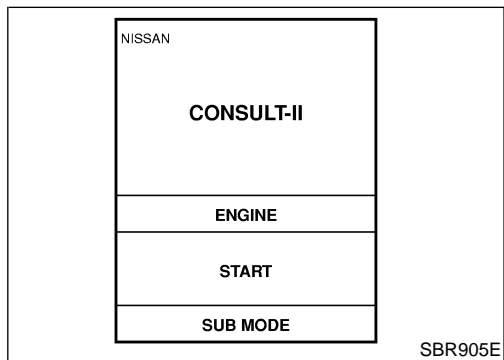

DATA MONITOR PROCEDURE

NFBR0110S03

1. Turn ignition switch OFF.
2. Connect CONSULT-II to data link connector.
3. Turn ignition switch ON.
4. Touch "START" on CONSULT-II screen.

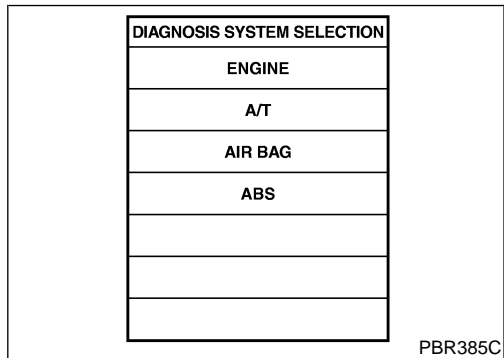

5. Touch "ABS".

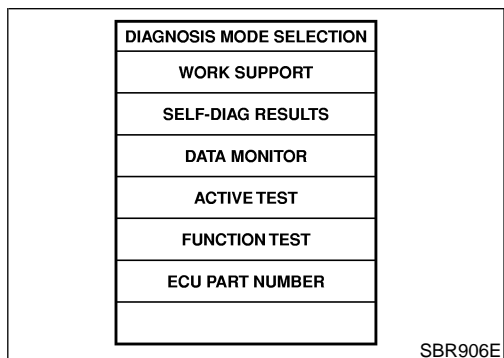

6. Touch "DATA MONITOR".
7. Touch "SETTING" on "SELECT MONITOR ITEM" screen.
8. Touch "START" on "SELECT MONITOR ITEM".

SELF-DIAGNOSTIC RESULTS MODE (FOR A/T MODELS)

=NFBR0110S07

Diagnostic item	Diagnostic item is detected when ...	Reference Page
FR RH SENSOR	● Circuit for front right wheel sensor is open.	BR-61
FR LH SENSOR	● Circuit for front left wheel sensor is open.	BR-61
RR RH SENSOR	● Circuit for rear right sensor is open.	BR-61
RR LH SENSOR	● Circuit for rear left sensor is open.	BR-61
FR RH SENSOR	● Power supply for sensors is out of specification. ● Control unit cannot confirm pulse from sensors.	BR-61
FR LH SENSOR	● Power supply for sensors is out of specification. ● Control unit cannot confirm pulse from sensors.	BR-61
RR RH SENSOR	● Power supply for sensors is out of specification. ● Control unit cannot confirm pulse from sensors.	BR-61
RR LH SENSOR	● Power supply for sensors is out of specification. ● Control unit cannot confirm pulse from sensors.	BR-61
FR RH IN ABS SOL	● Control unit detects malfunction on FR RH inlet solenoid.	BR-66
FR LH IN ABS SOL	● Control unit detects malfunction on FR LH inlet solenoid.	BR-66
RR RH IN ABS SOL	● Control unit detects malfunction on RR RH inlet solenoid.	BR-66
RR LH IN ABS SOL	● Control unit detects malfunction on RR LH inlet solenoid.	BR-66
FR RH OUT ABS SOL	● Control unit detects malfunction on FR RH outlet solenoid.	BR-66
FR LH OUT ABS SOL	● Control unit detects malfunction on FR LH outlet solenoid.	BR-66
RR RH OUT ABS SOL	● Control unit detects malfunction on RR RH outlet solenoid.	BR-66
RR LH OUT ABS SOL	● Control unit detects malfunction on RR LH outlet solenoid.	BR-66
ABS ACTUATOR RELAY [ABNORMAL]	● Control unit detects malfunction on ABS actuator relay.	BR-66
PUMP MOTOR	● Control unit detects malfunction on ABS motor and/or ABS motor relay.	BR-70
BATTERY VOLT [ABNORMAL]	● Power source voltage supplied to ABS control unit is abnormally low.	BR-73
CONTROL UNIT	● Function of calculation in ABS control unit has failed.	BR-75

*1: Be sure to confirm the ABS warning lamp illuminates when the ignition switch is turned ON after repairing the shorted sensor circuit, but the lamp goes out when driving the vehicle over 30 km/h (19 MPH) for one minute in accordance with SELF-DIAGNOSIS PROCEDURE.

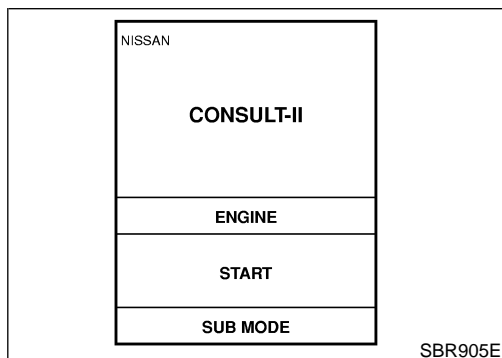

DATA MONITOR PROCEDURE

NFBR0110S08

1. Turn ignition switch OFF.
2. Connect CONSULT-II to data link connector.
3. Turn ignition switch ON.
4. Touch "START" on CONSULT-II screen.

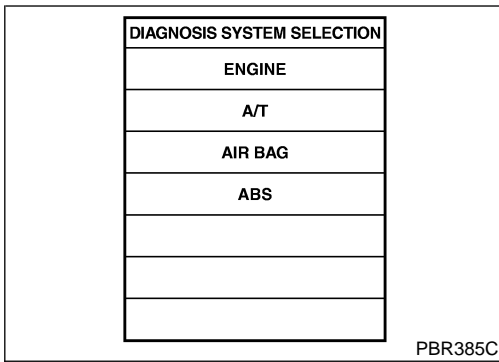

5. Touch "ABS".

GI

MA

EM

LC

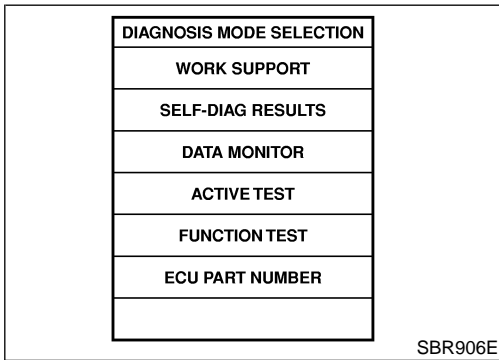

6. Touch "DATA MONITOR".

7. Touch "SETTING" on "SELECT MONITOR ITEM" screen.

8. Touch "START" on "SELECT MONITOR ITEM".

EC

FE

CL

MT

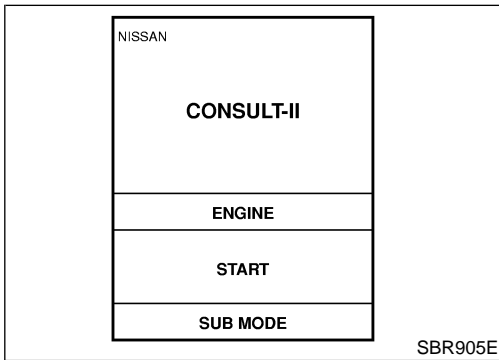

ACTIVE TEST PROCEDURE

NFBR0110S04

- When conducting Active test, vehicle must be stationary.
 - When ABS warning lamp stays on, never conduct Active test.
1. Turn ignition switch OFF.
 2. Connect CONSULT-II to Data Link Connector.
 3. Start engine.
 4. Touch "START" on CONSULT-II screen.

AT

AX

SU

BR

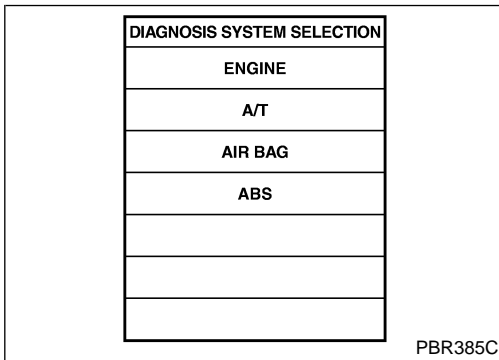

5. Touch "ABS".

ST

RS

BT

HA

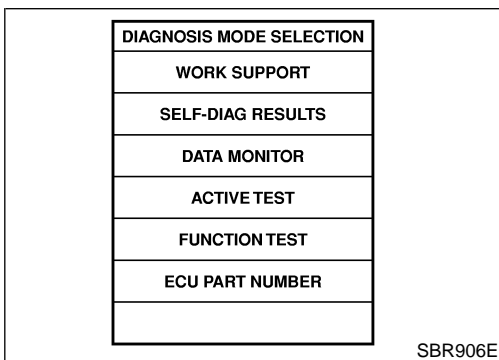

6. Touch "ACTIVE TEST".

SC

EL

IDX

ON BOARD DIAGNOSTIC SYSTEM DESCRIPTION

ABS

CONSULT-II Inspection Procedure (Cont'd)

SELECT TEST ITEM
FR RH SOL
FR LH SOL
RR RH SOL
RR LH SOL
ABS MOTOR
FR RH ABS SOLENOID (ACT)

SBR932E

7. Select active test item by touching screen.

FR RH SOL
SELECT MONITOR ITEM
MAIN SIGNALS
SELECTION FROM MENU

SBR933E

8. Touch "START".

9. Carry out the active test by touching screen key.

DATA MONITOR MODE

NFBR0110S05

MONITOR ITEM	CONDITION	SPECIFICATION
FR RH SENSOR FR LH SENSOR RR RH SENSOR RR LH SENSOR	Drive vehicle. (Each wheel is rotating.)	Displays computed vehicle speed from wheel sensor signal. Almost the same speed as speedometer.
STOP LAMP SW	Turn ignition switch ON and depress brake pedal.	Depress the pedal: ON Release the pedal: OFF
FR RH IN SOL FR RH OUT SOL FR LH IN SOL FR LH OUT SOL RR RH IN SOL RR RH OUT SOL RR LH IN SOL RR LH OUT SOL	Ignition switch is turned ON or engine is running.	Operating conditions for each solenoid valve are indicated. ABS is not operating: OFF
ACTUATOR RLY	Ignition switch is turned ON or engine is running.	Displays ON/OFF condition of ABS actuator relay. When turning ignition switch ON, ABS actuator relay is operated.
MOTOR RELAY		ABS is not operating: OFF ABS is operating: ON
ABS WARNING LAMP		Warning lamp is turned on: ON Warning lamp is turned off: OFF
BATTERY VOLT		Power supply voltage for control unit

ON BOARD DIAGNOSTIC SYSTEM DESCRIPTION

ABS

CONSULT-II Inspection Procedure (Cont'd)

MONITOR ITEM	CONDITION	SPECIFICATION	
EBD SIGNAL (12 For A/T models)	Ignition switch is turned ON.	EBD is operating: ON EBD is not operating: OFF	GI
ABS SIGNAL (12 For A/T models)		ABS is operating: ON ABS is not operating: OFF	MA
EBD FAIL SIG (12 For A/T models)		EBD system fails: ON EBD system does not fail: OFF	EM
ABS FAIL SIG (12 For A/T models)		ABS fails: ON ABS does not fail: OFF	LC

ACTIVE TEST MODE

NFBR0110S06

TEST ITEM	CONDITION	JUDGEMENT			
FR RH SOLENOID FR LH SOLENOID RR RH SOLENOID RR LH SOLENOID	Ignition switch is turned ON.	Brake fluid pressure control operation			EC
			IN SOL	OUT SOL	FE
		UP (Increase):	OFF	OFF	CL
		KEEP (Hold):	ON	OFF	MT
		DOWN (Decrease):	ON	ON	AT
ABS MOTOR		ABS actuator motor ON: Motor runs OFF: Motor stops			AT

NOTE:

Active test will automatically stop ten seconds after the test starts. (TEST IS STOPPED monitor shows ON.)

GI
MA
EM
LC
EC
FE
CL
MT
AT
AX
SU
BR
ST
RS
BT
HA
SC
EL
IDX

How to Perform Trouble Diagnoses for Quick and Accurate Repair

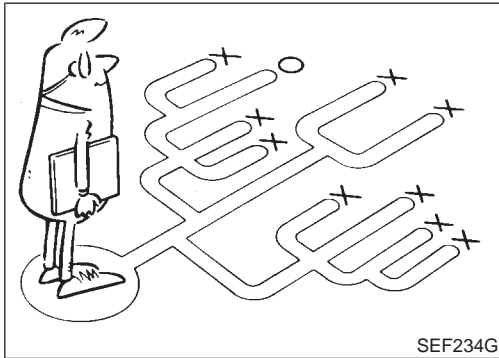
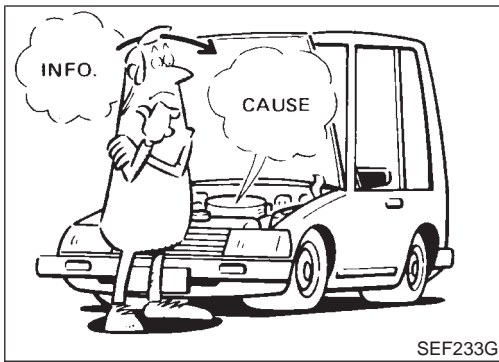

How to Perform Trouble Diagnoses for Quick and Accurate Repair

INTRODUCTION

NFBR0111

NFBR0111S01

The ABS system has an electronic control unit to control major functions. The control unit accepts input signals from sensors and instantly drives actuator. It is essential that both kinds of signals are proper and stable. It is also important to check for conventional problems: such as air leaks in the booster or lines, lack of brake fluid, or other problems with the brake system.

It is much more difficult to diagnose a problem that occurs intermittently rather than continuously. Most intermittent problems are caused by poor electric connections or faulty wiring. In this case, careful checking of suspicious circuits may help prevent the replacement of good parts.

A visual check only may not find the cause of the problems, so a road test should be performed.

Before undertaking actual checks, take just a few minutes to talk with a customer who approaches with a ABS complaint. The customer is a very good source of information on such problems; especially intermittent ones. Through the talks with the customer, find out what symptoms are present and under what conditions they occur.

Start your diagnosis by looking for “conventional” problems first. This is one of the best ways to troubleshoot brake problems on an ABS controlled vehicle. Also check related Service Bulletins for information.

Preliminary Check

NFBR0112

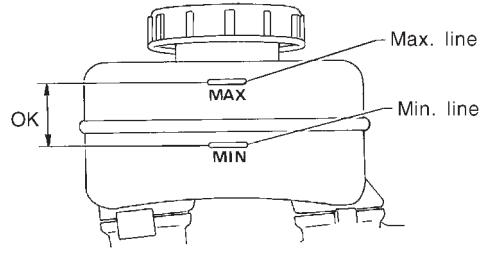
1	CHECK BRAKE FLUID LEVEL	
<p>Check brake fluid level in reservoir tank. Low fluid level may indicate brake pad wear or leakage from brake line.</p> <div style="text-align: center;">  </div> <p style="text-align: right;">SBR451D</p>		
<p>Is brake fluid filled between MAX and MIN lines on reservoir tank and/or has brake fluid been contaminated?</p>		
Yes	▶	GO TO 2.
No	▶	Repair. GO TO 2.

GI
MA
EM
LC
EC
FE
CL
MT
AT
AX
SU
BR
ST
RS
BT
HA
SC
EL
IDX

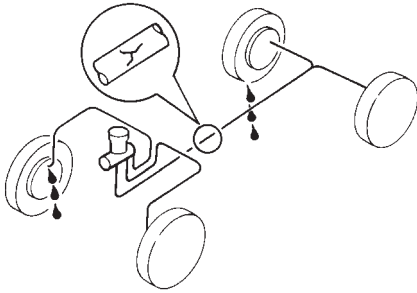
2	CHECK BRAKE LINE	
<p>Check brake line for leakage.</p> <div style="text-align: center;">  </div> <p style="text-align: right;">SBR389C</p>		
<p>Is leakage present at or around brake lines, tubes or hoses or are any of these parts cracked or damaged?</p>		
Yes	▶	Repair. GO TO 3.
No	▶	GO TO 3.

Preliminary Check (Cont'd)

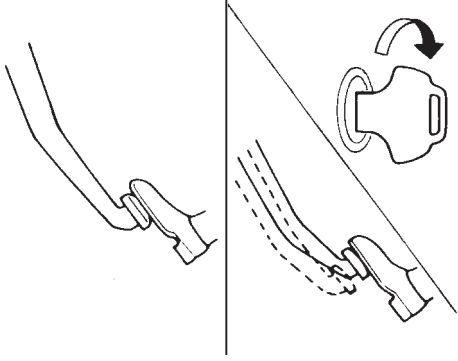
3	CHECK BRAKE BOOSTER OPERATION	
<p>Check brake booster for operation and air tightness. Refer to BR-20.</p> <div style="text-align: center;">  </div> <p style="text-align: right;">SBR058C</p>		
Is brake booster airtight and functioning properly?		
Yes	▶	GO TO 4.
No	▶	Replace. GO TO 4.

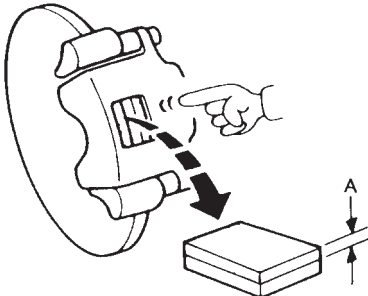
4	CHECK BRAKE PAD AND ROTOR	
<p>Check brake pad and rotor. Refer to BR-23, BR-25, BR-27, BR-31.</p> <div style="text-align: center;">  </div> <p style="text-align: right;">SBR059C</p>		
Are brake pads and rotors functioning properly?		
Yes	▶	GO TO 5.
No	▶	Replace.

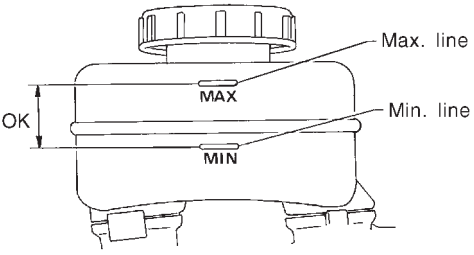
5	RECHECK BRAKE FLUID LEVEL	
Check brake fluid level in reservoir tank again.		
		
SBR451D		
Is brake fluid filled between MAX and MIN lines on reservoir tank and/or has brake fluid been contaminated?		
Yes	▶	GO TO 6.
No	▶	Fill up brake fluid.

GI
MA
EM
LC
EC
FE
CL

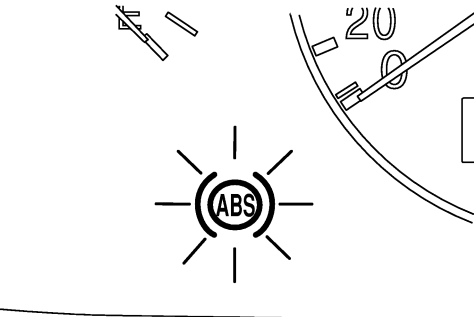
6	CHECK WARNING LAMP ACTIVATION	
Check warning lamp activation.		
		
SBR588E		
Does warning lamp turn on when ignition switch is turned "ON"?		
Yes	▶	GO TO 7.
No	▶	Check fuse, warning lamp bulb and warning lamp circuit.

MT
AT
AX
SU
BR

7	CHECK WARNING LAMP DEACTIVATION	
Check warning lamp for deactivation after engine is started.		
Does warning lamp turn off when engine is started?		
Yes	▶	GO TO 8.
No	▶	Go to Self-diagnosis. Refer to BR-48.

RS
BT
HA

8	DRIVE VEHICLE	
Drive vehicle at speeds over 30 km/h (19 MPH) for at least one minute.		
Does warning lamp remain off after vehicle has been driven at 30 km/h (19 MPH) for at least one minute?		
Yes	▶	END
No	▶	Go to Self-diagnosis. Refer to BR-48.

SC
EL
IDX

Ground Circuit Check

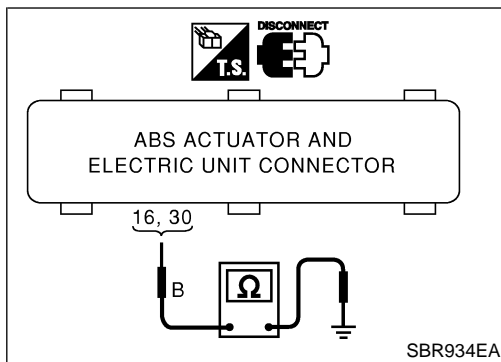
**Ground Circuit Check**

NFBR0113

ABS ACTUATOR AND ELECTRIC UNIT GROUND

NFBR0113S01

- Check continuity between ABS actuator and electric unit harness connector E9 (M/T models), E169 (A/T models) terminals 16 (B), 30 (B) and ground.

Continuity should exist.

Wheel Sensor or Rotor
DIAGNOSTIC PROCEDURE

NFBR0136

NFBR0136S01

1	INSPECTION START		
Wheel sensor inspection		<p>For M/T models</p> <p>For A/T models</p>	<p>GI</p> <p>MA</p> <p>EM</p> <p>LC</p> <p>EC</p> <p>SBR047F</p> <p>FE</p> <p>CL</p> <p>MT</p> <p>AT</p> <p>AX</p>
▶		GO TO 2.	<p>SBR981E</p>

2	CHECK CONNECTOR	<p>1. Disconnect connectors from control unit and wheel sensor of malfunction detected. Check terminals for damage or loose connections. Then reconnect connectors.</p> <p>2. Carry out self-diagnosis again.</p> <p style="text-align: center;">Does warning lamp activate again?</p>	
Yes ▶		For M/T models: GO TO 3.	<p>BR</p> <p>ST</p>
▶		For A/T models: GO TO 4.	<p>RS</p>
No ▶		INSPECTION END	<p>BT</p> <p>HA</p> <p>SC</p> <p>EL</p> <p>IDX</p>

Wheel Sensor or Rotor (Cont'd)

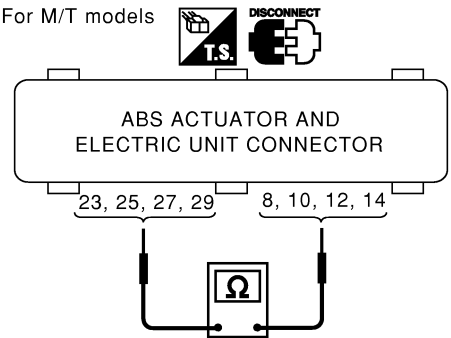
3	CHECK WHEEL SENSOR CIRCUIT FOR M/T MODELS
<p>1. Disconnect control unit connector. 2. Check resistance between control unit harness connector E9 terminals. Front RH wheel Terminals 10 (B/W) and 25 (OR) Front LH wheel Terminals 8 (G) and 23 (R/B) Rear RH wheel Terminals 14 (B) and 29 (W) Rear LH wheel Terminals 12 (R/W) and 27 (L/W) Resistance: 0.8 - 1.85 kΩ</p>	
<p>For M/T models</p>  <p style="text-align: right;">SBR936EA</p>	
Is resistance 0.8 - 1.85 kΩ?	
Yes	▶ GO TO 6.
No	▶ GO TO 5.

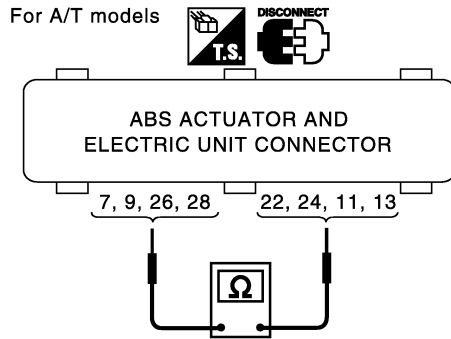
4	CHECK WHEEL SENSOR CIRCUIT FOR A/T MODELS
<p>1. Disconnect control unit connector. 2. Check resistance between control unit connector terminals. Front RH wheel Terminals 9 (B/W) and 24 (L/OR) Front LH wheel Terminals 7 (G) and 22 (R/B) Rear RH wheel Terminals 28 (W) and 13 (B) Rear LH wheel Terminals 26 (L/W) and 11 (R/W) Resistance: 0.8 - 1.85 kΩ</p>	
<p>For A/T models</p>  <p style="text-align: right;">SBR045F</p>	
Is resistance 0.8 - 1.85 kΩ?	
Yes	▶ GO TO 6.
No	▶ GO TO 5.

5	CHECK WHEEL SENSOR
	<ul style="list-style-type: none"> ● Check resistance of each sensor. (See NOTE.) Resistance: 0.8 - 1.85 kΩ (For M/T model) ● Check signal from sensors by "Simple oscilloscope" function of CONSULT-II (For A/T model) (Scale: 0.2 V/Div, 20 ms/Div) <div style="text-align: center; margin: 10px 0;"> <p>For M/T models</p> </div> <div style="display: flex; justify-content: space-around; text-align: center;"> <div style="width: 20%;">Front RH sensor (E76)</div> <div style="width: 20%;">Front LH sensor (E145)</div> <div style="width: 20%;">Rear RH sensor (B16)</div> <div style="width: 20%;">Rear LH sensor (B28)</div> </div> <div style="text-align: center; margin: 10px 0;"> <p>For A/T models</p> </div> <div style="display: flex; justify-content: space-around; text-align: center;"> <div style="width: 20%;">Front RH sensor (E159)</div> <div style="width: 20%;">Front LH sensor (E170)</div> <div style="width: 20%;">Rear RH sensor (B55)</div> <div style="width: 20%;">Rear LH sensor (B54)</div> </div> <div style="text-align: right; margin-top: 10px;">SBR937E</div>
	SBR050F
	Is resistance 0.8 - 1.85 kΩ? (For M/T model)/Does the wave appear on screen when wheel is rotated? (For A/T model)
Yes	▶ Repair harness and connectors between control unit connector and wheel sensor connector.
No	▶ Replace wheel sensor.

6	CHECK TIRE
	<p>Check for inflation pressure, wear and size of each tire.</p> <p style="text-align: center;">Are tire pressure and size correct and is tire wear within specifications?</p>
Yes	▶ GO TO 7.
No	▶ Adjust tire pressure or replace tire(s).

GI
MA
EM
LC
EC
FE
CL
MT
AT
AX
SU
BR
ST
RS
BT
HA
SC
EL
IDX

TROUBLE DIAGNOSES FOR SELF-DIAGNOSTIC ITEMS

ABS

Wheel Sensor or Rotor (Cont'd)

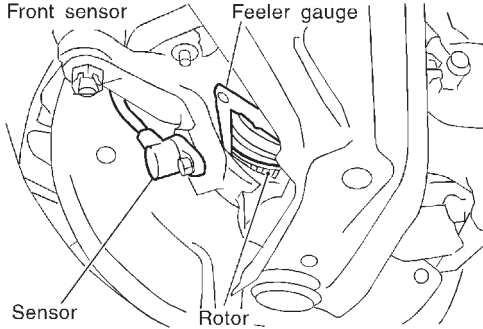
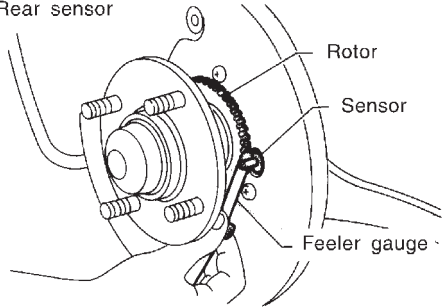
7	CHECK WHEEL BEARING	
<p>Check wheel bearing axial end play. Check clearance between sensor and rotor.</p> <p>Clearance: Front 0.273 - 0.925 mm (0.0107 - 0.0364 in) Rear 0.385 - 0.973 mm (0.0152 - 0.0383 in)</p>		
 <p>Front sensor Feeler gauge</p> <p>Sensor Rotor</p>		
SBR333E		
 <p>Rear sensor</p> <p>Rotor</p> <p>Sensor</p> <p>Feeler gauge</p>		
SBR069CA		
Is axial end play and clearance within specifications?		
Yes	▶	GO TO 8.
No	▶	Clean sensor fixing portion, or replace sensor.

8	CHECK SENSOR ROTOR	
Check sensor rotor for teeth damage.		
Is sensor rotor free from damage?		
Yes	▶	For M/T models: Check control unit pin terminals for damage or the connection of control unit harness connector. Reconnect control unit harness connector. Then retest. For A/T models: GO TO 9.
No	▶	Replace sensor rotor.

TROUBLE DIAGNOSES FOR SELF-DIAGNOSTIC ITEMS

ABS

Wheel Sensor or Rotor (Cont'd)

9	CHECK POWER SUPPLY
<p>1. Disconnect wheel sensor connector. 2. Check voltage between body side terminal of wheel sensor connectors and body ground.</p> <div style="text-align: center;"> <p>FR-RH FR-LH RR-RH RR-LH</p> <p>1 1 1 1</p> <p style="text-align: right;">SBR984E</p> </div> <p style="text-align: center;">Is voltage more than 8V?</p>	
Yes	▶ Replace wheel sensor.
No	▶ Replace ABS control unit.

GI

MA

EM

LC

EC

FE

CL

MT

AT

AX

SU

BR

ST

RS

BT

HA

SC

EL

IDX

ABS Actuator Solenoid Valve or Solenoid Valve Relay

DIAGNOSTIC PROCEDURE

=NFBR0116

NFBR0116S01

1 INSPECTION START

Solenoid valve relay inspection

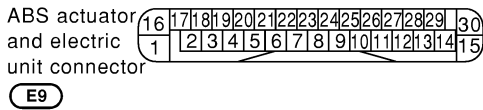
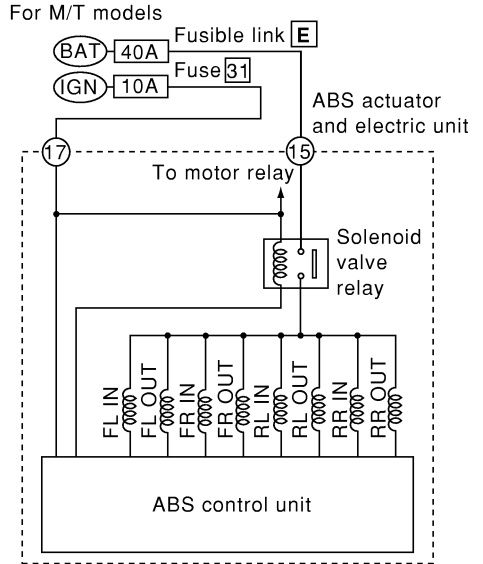

SBR938E

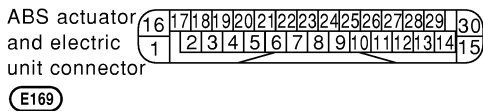
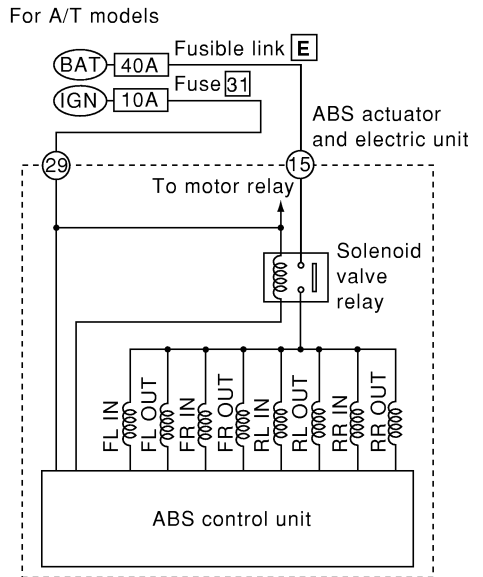

SBR987E

▶ GO TO 2.

TROUBLE DIAGNOSES FOR SELF-DIAGNOSTIC ITEMS

ABS

ABS Actuator Solenoid Valve or Solenoid Valve Relay (Cont'd)

2	CHECK SOLENOID VALVE POWER SUPPLY CIRCUIT	
Check 40A [E] fusible link (ABS ACTR) for ABS solenoid valve relay. For fusible link layout, refer to POWER SUPPLY ROUTING in EL section.		
Is fusible link OK?		
Yes	▶	GO TO 3.
No	▶	GO TO 7.

GI
MA
EM

3	CHECK FUSE	
Check 10A fuse No. 31. For fuse layout, refer to "POWER SUPPLY ROUTING" in EL section.		
Is fuse OK?		
Yes	▶	GO TO 4.
No	▶	GO TO 9.

LC
EC
FE

4	CHECK CONNECTOR	
1. Disconnect connectors from control unit and ABS actuator. Check terminals for damage or loose connection. Then reconnect connectors. 2. Carry out self-diagnosis again.		
Does warning lamp activate again?		
Yes	▶	GO TO 5.
No	▶	INSPECTION END

CL
MT
AT

5	CHECK GROUND CIRCUIT	
Refer to ABS ACTUATOR AND ELECTRIC UNIT in Ground Circuit Check, BR-60.		
Is ground circuit OK?		
Yes	▶	GO TO 6.
No	▶	Repair harness and connectors.



AX
SU
BR

ST
RS
BT
HA
SC
EL
IDX

TROUBLE DIAGNOSES FOR SELF-DIAGNOSTIC ITEMS

ABS

ABS Actuator Solenoid Valve or Solenoid Valve Relay (Cont'd)

6	CHECK SOLENOID VALVE POWER SUPPLY CIRCUIT	
<p>1. Disconnect ABS actuator and electric unit connector.</p> <p>2. Check voltage between ABS actuator and electric unit harness connector E9 for M/T models/E169 for A/T models, terminals 17 (GY) for M/T models/29 (GY) for A/T models and ground.</p>		
<p>For M/T models</p> 		
SBR049F		
<p>For A/T models</p> 		
SBR993EA		
Does battery voltage exist when ignition switch is turned ON?		
Yes	▶	Replace ABS actuator and electric unit.
No	▶	<p>Check the following.</p> <ul style="list-style-type: none"> ● Harness connector E9 for M/T models and E169 for A/T models. ● Harness for open or short between ABS actuator and electric unit and fusible link <p>If NG, repair harness or connectors.</p>

7	REPLACE FUSIBLE LINK	
Replace fusible link.		
Does the fusible link blow out when ignition switch is turned "ON"?		
Yes	▶	GO TO 8.
No	▶	INSPECTION END

TROUBLE DIAGNOSES FOR SELF-DIAGNOSTIC ITEMS

ABS

ABS Actuator Solenoid Valve or Solenoid Valve Relay (Cont'd)

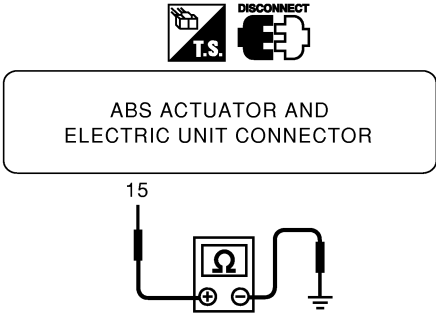
8	CHECK RELAY UNIT POWER SUPPLY CIRCUIT FOR SHORT	
<p>1. Disconnect battery cable and ABS actuator and electric unit connector. 2. Check continuity between ABS actuator and electric unit harness connector E9 for M/T models/E169 for A/T models, terminal 15 (L/B) and ground.</p> <div style="text-align: center;">  <p style="text-align: right; margin-right: 50px;">SBR940EA</p> </div> <p style="text-align: center;">Does continuity exist?</p>		
Yes	▶	<p>Check the following.</p> <ul style="list-style-type: none"> ● Harness connector E9 for M/T models and E169 for A/T models. ● Harness for open or short between ABS actuator and electric unit and fusible link If NG, repair harness or connectors.
No	▶	Replace ABS actuator and electric unit.

9	REPLACE FUSE	
Replace fuse.		
Does the fuse blow out when ignition switch is turned "ON"?		
Yes	▶	<p>Check the following.</p> <ul style="list-style-type: none"> ● Harness connector E9 for M/T models and E169 for A/T models. ● Harness for open or short between ABS actuator and electric unit and fuse If NG, repair harness or connectors.
No	▶	INSPECTION END

GI
 MA
 EM
 LC
 EC
 FE
 CL
 MT
 AT
 AX
 SU
 BR
 ST
 RS
 BT
 HA
 SC
 EL
 IDX

Motor Relay or Motor DIAGNOSTIC PROCEDURE

=NFBR0117

NFBR0117S01

1 INSPECTION START

ABS motor relay inspection

For M/T models

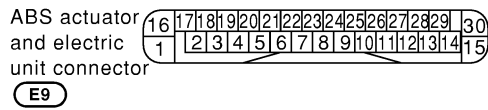
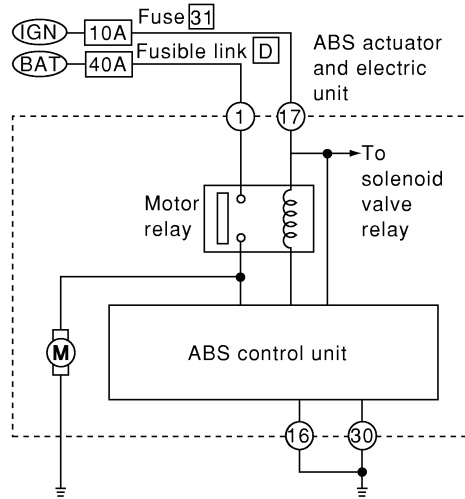

SBR990E

For A/T models

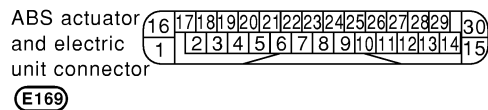
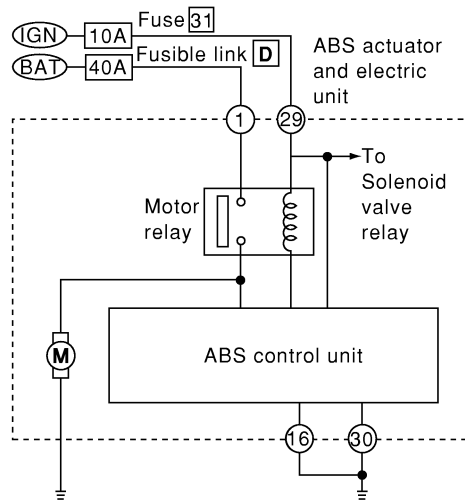

SBR941E



GO TO 2.

TROUBLE DIAGNOSES FOR SELF-DIAGNOSTIC ITEMS

ABS



Motor Relay or Motor (Cont'd)

2	CHECK MOTOR POWER SUPPLY CIRCUIT	
Check 40A [D] fusible link (ABS MTR) for ABS motor relay. For fusible link layout, refer to POWER SUPPLY ROUTING in EL section.		
Is fusible link OK?		
Yes	▶	GO TO 3.
No	▶	GO TO 6.

GI
MA
EM

3	CHECK CONNECTOR	
1. Disconnect ABS actuator and electric unit connector. Check terminals for damage or loose connection. Then reconnect connectors. 2. Carry out self-diagnosis again.		
Does warning lamp activate again?		
Yes	▶	GO TO 4.
No	▶	INSPECTION END

LC
EC
FE

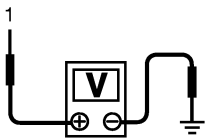
4	CHECK MOTOR RELAY POWER SUPPLY CIRCUIT	
1. Disconnect ABS actuator and electric unit connector. 2. Check voltage between ABS actuator and electric unit harness connector E9 for M/T models/E169 for A/T models, terminal 1 (Y) and ground.		
<div style="display: flex; justify-content: center; align-items: center; gap: 20px;">   </div> <div style="border: 1px solid black; border-radius: 10px; padding: 5px; text-align: center; margin: 10px auto; width: 60%;"> ABS ACTUATOR AND ELECTRIC UNIT CONNECTOR </div> <div style="text-align: center; margin: 10px auto;">  </div>		
SBR942EA		
Does battery voltage exist?		
Yes	▶	GO TO 5.
No	▶	Check the following. <ul style="list-style-type: none"> Harness connector E9 for M/T models and E169 for A/T models. Harness for open or short between ABS actuator and electric unit and fusible link If NG, repair harness or connectors.

CL
MT
AT
AX
SU

BR

ST
RS
BT

5	CHECK ABS ACTUATOR AND ELECTRIC UNIT GROUND CIRCUIT	
Refer to ABS ACTUATOR AND ELECTRIC UNIT GROUND in Ground Circuit Check, BR-60.		
Is ground circuit OK?		
Yes	▶	Replace ABS actuator and electric unit.
No	▶	Check the following. <ul style="list-style-type: none"> Harness connector E9 for M/T models and E169 for A/T models. Harness for open or short between ABS actuator and electric unit and ground If NG, repair harness or connectors.

HA
SC
EL
IDX

TROUBLE DIAGNOSES FOR SELF-DIAGNOSTIC ITEMS

ABS

Motor Relay or Motor (Cont'd)

6	REPLACE FUSIBLE LINK	
Replace fusible link.		
Does the fusible link blow out when ignition switch is turned "ON"?		
Yes	▶	GO TO 7.
No	▶	INSPECTION END

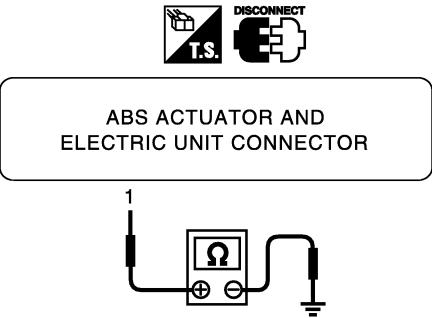
7	CHECK ABS ACTUATOR MOTOR POWER SUPPLY CIRCUIT	
<p>1. Disconnect battery cable and ABS actuator and electric unit connector.</p> <p>2. Check continuity between ABS actuator and electric unit harness connector E9 for M/T models/E169 for A/T models, terminal 1 (Y) and ground.</p>		
		
SBR037F		
Does continuity exist?		
Yes	▶	Check ABS actuator and electric unit pin terminals for damage or the connection of ABS actuator and electric unit harness connector. Reconnect ABS actuator and electric unit harness connector. Then retest.
No	▶	<p>Check the following.</p> <ul style="list-style-type: none"> ● Harness connector E9 for M/T models and E169 for A/T models. ● Harness for open or short between ABS actuator and electric unit and fusible link <p>If NG, repair harness or connectors.</p>

Low Voltage DIAGNOSTIC PROCEDURE

NFBR0154

NFBR0154S01

1	INSPECTION START	<p>ABS actuator and electric unit power supply and ground circuit inspection</p> <p>For M/T models</p> <p style="text-align: right;">SBR943E</p> <p>For A/T models</p> <p style="text-align: right;">SBR992E</p>	GI MA EM LC EC FE CL MT AT AX
▶ GO TO 2.			SU BR ST RS BT HA SC EL IDX

2	CHECK CONNECTOR	<p>1. Disconnect ABS actuator and electric unit connector. Check terminals for damage or loose connections. Then reconnect connector.</p> <p>2. Carry out self-diagnosis again.</p> <p style="text-align: center;">Does warning lamp activate again?</p>	
Yes	▶	GO TO 3.	
No	▶	INSPECTION END	

Low Voltage (Cont'd)

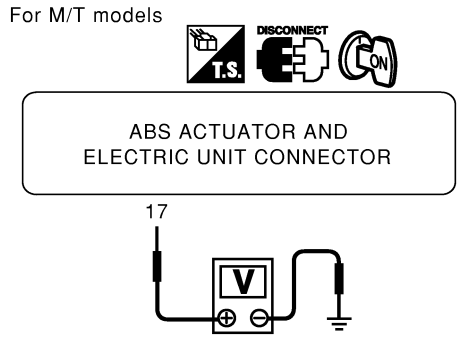
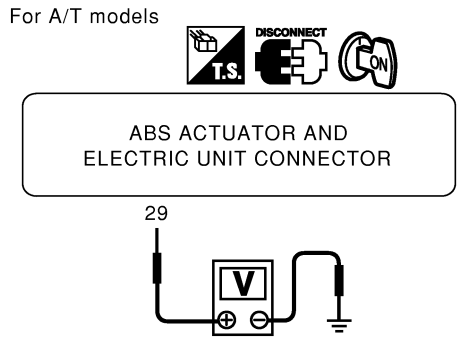
3	CHECK ABS ACTUATOR AND ELECTRIC UNIT POWER SUPPLY CIRCUIT	
<p>1. Disconnect ABS actuator and electric unit connector.</p> <p>2. Check voltage between ABS actuator and electric unit harness connector E9 for M/T models/E169 for A/T models, terminal 17 (GY) for M/T models/29 (GY) for A/T models and ground.</p>		
<p>For M/T models</p> 		
SBR944EA		
<p>For A/T models</p> 		
SBR993EA		
Does battery voltage exist when ignition switch is turned ON?		
Yes	▶	GO TO 4.
No	▶	GO TO 5.

4	CHECK ABS ACTUATOR AND ELECTRIC UNIT GROUND	
Refer to ABS ACTUATOR AND ELECTRIC UNIT GROUND in Ground Circuit Check, BR-60.		
Is ground circuit OK?		
OK	▶	Check ABS actuator and electric unit pin terminals for damage or the connection of ABS actuator and electric unit harness connector. Reconnect ABS actuator and electric unit harness connector. Then retest.
NG	▶	<p>Check the following.</p> <ul style="list-style-type: none"> ● Harness connector E9 for M/T models and E169 for A/T models. ● Harness for open or short between ABS actuator and electric unit and ground <p>If NG, repair harness or connectors.</p>

5	CHECK FUSE	
Check 10A fuse 31 (Engine control) for control unit. Refer to POWER SUPPLY ROUTING in EL section.		
Is fuse OK?		
Yes	▶	GO TO 6.
No	▶	Replace fuse.

6	CHECK ABS ACTUATOR AND ELECTRIC UNIT POWER SUPPLY CIRCUIT	
Check continuity between battery and ABS actuator and electric unit connector terminal 17 for M/T models/29 for A/T models.		
Does continuity exist?		
Yes	▶	Check battery. Refer to BATTERY in EL section.
No	▶	Check the following. <ul style="list-style-type: none"> ● Harness connector E9 for M/T models and E169 for A/T models. ● Harness for open or short between ABS actuator and electric unit and fuse If NG, repair harness or connectors.

GI
MA
EM
LC
EC
FE
CL
MT
AT
AX
SU
BR
ST
RS
BT
HA
SC
EL
IDX

Control Unit DIAGNOSTIC PROCEDURE

NFBR0137

NFBR0137S01

1	INSPECTION START	
ABS actuator and electric unit power supply and ground circuit inspection		
For M/T models		
SBR945E		
For A/T models		
SBR994E		
▶		GO TO 2.

2	CHECK CONNECTOR	
1. Disconnect ABS actuator and electric unit connector. Check terminals for damage or loose connections. Then reconnect connectors. 2. Carry out self-diagnosis again.		
Does warning lamp activate again?		
Yes	▶	GO TO 3.
No	▶	INSPECTION END

TROUBLE DIAGNOSES FOR SELF-DIAGNOSTIC ITEMS

ABS

Control Unit (Cont'd)

3	CHECK ABS ACTUATOR AND ELECTRIC UNIT POWER SUPPLY CIRCUIT
Check voltage. Refer to "3. CHECK ABS ACTUATOR AND ELECTRIC UNIT POWER SUPPLY CIRCUIT" in "Low Voltage", BR-73.	
Does battery voltage exist when ignition switch is turned ON?	
Yes	▶ GO TO 4.
No	▶ Repair.

4	CHECK SELF-DIAGNOSIS RESULT
Is "Control unit" indicated on SELF-DIAGNOSIS RESULT again?	
Yes	▶ Replace ABS actuator and electric unit.
No	▶ Inspect the system according to the SELF-DIAGNOSIS RESULT.

1. ABS Works Frequently

NFBR0138

1	CHECK WHEEL SENSOR	
1. Check wheel sensor connector for terminal damage or loose connections. 2. Perform wheel sensor mechanical check. Refer to "Wheel Sensor or Rotor", BR-61.		
Are wheel sensors functioning properly?		
Yes	▶	GO TO 2.
No	▶	Repair.

2	CHECK FRONT AND REAR AXLES	
Check front and rear axles for excessive looseness. Refer to AX section, "Front Wheel Bearing", "ON-VEHICLE SERVICE" and "Rear Wheel Bearing", "ON-VEHICLE SERVICE".		
Is front axle installed properly?		
Yes	▶	Go to "3. CHECK WARNING LAMP INDICATION" in "2. Unexpected Pedal Action", BR-77.
No	▶	Repair.

2. Unexpected Pedal Action

NFBR0139

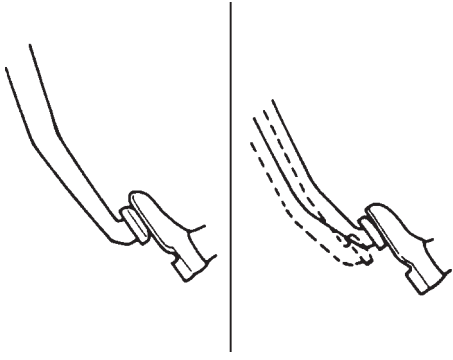
1	CHECK BRAKE PEDAL STROKE	
Check brake pedal stroke. Is stroke excessively large?		
		
SBR540A		
Yes	▶	Perform Preliminary Check. Refer to BR-57.
No	▶	GO TO 2.

2	CHECK CONNECTOR AND PERFORMANCE	
1. Disconnect ABS actuator and electric unit connector. 2. Check whether brake is effective.		
Yes or No?		
Yes	▶	GO TO 3.
No	▶	Perform Preliminary Check. Refer to BR-57.

GI
MA
EM
LC
EC
FE
CL
MT
AT
AX
SU
BR
ST
RS
BT
HA
SC
EL
IDX

TROUBLE DIAGNOSES FOR SYMPTOMS

ABS

2. Unexpected Pedal Action (Cont'd)

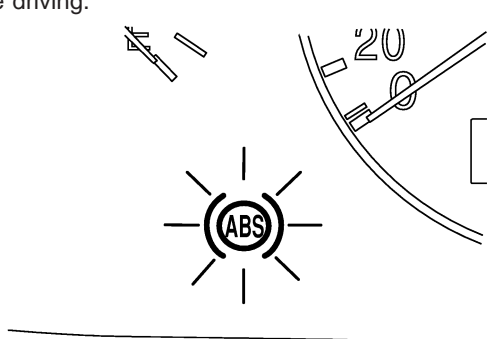
3	CHECK WARNING LAMP INDICATION	
<p>Ensure warning lamp remains off while driving.</p> <div style="text-align: center;">  </div> <p style="text-align: right;">SBR588E</p>		
Is warning lamp turned off?		
Yes	▶	GO TO 4.
No	▶	Carry out self-diagnosis. Refer to BR-48.

4	CHECK WHEEL SENSOR	
<p>1. Check wheel sensor connector for terminal damage or loose connection. 2. Perform wheel sensor mechanical check.</p>		
Is wheel sensor mechanism OK?		
Yes	▶	Check ABS actuator and electric unit pin terminals for damage or the connection of ABS actuator and electric unit harness connector. Reconnect ABS actuator and electric unit harness connector. Then retest.
No	▶	Repair.

3. Long Stopping Distance

NFBR0140

1	CHECK CONNECTOR AND PERFORMANCE	
<p>1. Cancel ABS by disconnecting ABS actuator and electric unit connector. 2. Check whether stopping distance is still long.</p>		
OK or NG		
OK	▶	Perform Preliminary Check and air bleeding.
NG	▶	Go to "3. CHECK WARNING LAMP INDICATION" in "2. Unexpected Pedal Action", BR-77.

NOTE:

Stopping distance may be longer than vehicles without ABS when road condition is slippery.

4. ABS Does Not Work

NFBR0141

1	CHECK WARNING LAMP INDICATION	
Does the ABS warning lamp activate?		
Yes	▶	Carry out self-diagnosis. Refer to BR-48.
No	▶	Go to "3. CHECK WARNING LAMP INDICATION" in "2. Unexpected Pedal Action", BR-77.

NOTE:

ABS does not work when vehicle speed is under 10 km/h (6 MPH).

- GI
- MA
- EM
- LC
- EC
- FE
- CL
- MT
- AT
- AX
- SU
- BR**
- ST
- RS
- BT
- HA
- SC
- EL
- IDX

5. Pedal Vibration and Noise

=NFBR0142

1	INSPECTION START
Pedal vibration and noise inspection	
	
SAT797A	
▶	GO TO 2.

2	CHECK SYMPTOM
1. Apply brake. 2. Start engine.	
Does the symptom appear only when engine is started?	
Yes	▶ Carry out self-diagnosis. Refer to BR-48.
No	▶ GO TO 3.

3	RECHECK SYMPTOM
Does the symptom appear when electrical equipment switches (such as headlamp) are operated?	
Yes	▶ INSPECTION END
No	▶ Go to "3. CHECK WARNING LAMP INDICATION" in "2. Unexpected Pedal Action", BR-77.

NOTE:

ABS may operate and cause vibration under any of the following conditions.

- Applying brake gradually when shifting or operating clutch.
- Low friction (slippery) road.
- High speed cornering.
- Driving over bumps and pot holes.
- Engine speed is over 5,000 rpm with vehicle stopped.

6. ABS Warning Lamp Does Not Come On When Ignition Switch Is Turned On

=NFBR0143



1	INSPECTION START	<p>Warning lamp circuit inspection</p> <div style="text-align: center;"> <p>For M/T models</p> <p>For A/T models</p> </div> <p style="text-align: right;">SBR946E</p> <p style="text-align: right;">SBR996E</p>	<p>GI</p> <p>MA</p> <p>EM</p> <p>LC</p> <p>EC</p> <p>FE</p> <p>CL</p> <p>MT</p> <p>AT</p> <p>AX</p>
▶ GO TO 2.			

2	CHECK FUSE	<p>Check 10A fuse No. 30 for warning lamp. For fuse layout, refer to "POWER SUPPLY ROUTING" in EL section.</p> <p style="text-align: center;">Is fuse OK?</p> <table border="1" style="width: 100%; border-collapse: collapse;"> <tr> <td style="width: 20%;">Yes</td> <td style="width: 5%; text-align: center;">▶</td> <td style="width: 75%;">GO TO 3.</td> </tr> <tr> <td>No</td> <td style="text-align: center;">▶</td> <td>Replace fuse.</td> </tr> </table>	Yes	▶	GO TO 3.	No	▶	Replace fuse.	<p>SU</p> <p style="background-color: black; color: white; padding: 5px;">BR</p> <p>ST</p> <p>RS</p> <p>BT</p> <p>HA</p> <p>SC</p> <p>EL</p> <p>IDX</p>
Yes	▶	GO TO 3.							
No	▶	Replace fuse.							

TROUBLE DIAGNOSES FOR SYMPTOMS

ABS

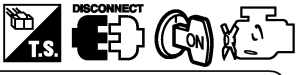
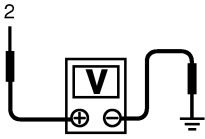
6. ABS Warning Lamp Does Not Come On When Ignition Switch Is Turned On (Cont'd)

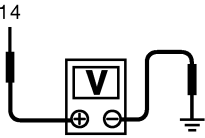
3	CHECK ABS CONTROL UNIT POWER SUPPLY CIRCUIT	
<p>1. Install 10A fuse.</p> <p>2. Check voltage between control unit harness connector E9 for M/T models/E169 for A/T models, terminal 2 (L/Y) for M/T models/14 (L/Y) for A/T models and ground after turning ignition switch "ON".</p>		
<p>For M/T models</p>  <div style="border: 1px solid black; padding: 5px; width: fit-content; margin: 10px auto;"> <p style="text-align: center;">ABS ACTUATOR AND ELECTRIC UNIT CONNECTOR</p> </div> 		
SBR947EA		
<p>For A/T models</p>  <div style="border: 1px solid black; padding: 5px; width: fit-content; margin: 10px auto;"> <p style="text-align: center;">ABS ACTUATOR AND ELECTRIC UNIT CONNECTOR</p> </div> 		
SBR995EA		
Does battery voltage exist after turning ignition switch "ON"?		
Yes	▶	GO TO 5.
No	▶	GO TO 4.

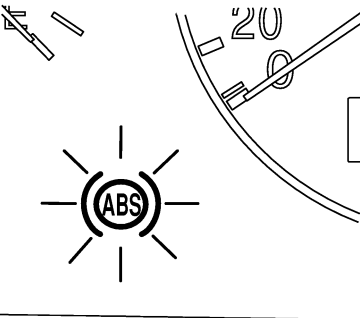
4	CHECK WARNING LAMP INDICATION	
<p>Disconnect ABS actuator and electric unit connector.</p>		
		
SBR588E		
Does the ABS warning lamp activate?		
Yes	▶	GO TO 6.
No	▶	GO TO 5.

TROUBLE DIAGNOSES FOR SYMPTOMS

ABS

6. ABS Warning Lamp Does Not Come On When Ignition Switch Is Turned On (Cont'd)

5	CHECK HARNESS FOR SHORT	
<p>1. Disconnect ABS actuator and electric unit connector. 2. Check voltage between ABS actuator and electric unit harness connector E9 for M/T models/E169 for A/T models, terminal 2 (L/R) for M/T models/14 (L/R) for A/T models and ground.</p>		
<p>For M/T models</p> <p style="text-align: right;">SBR948EA</p>		
<p>For A/T models</p> <p style="text-align: right;">SBR997EA</p>		
Does battery voltage exist?		
Yes	▶	Check combination meter. Refer to WARNING LAMPS in EL section.
No	▶	Repair harness and connectors between fuse and ABS actuator and electric unit connector terminal 2 for M/T models and 14 for A/T models.

6	CHECK HARNESS CONNECTOR	
Check ABS actuator and electric unit pin terminals for damage or connection of ABS actuator and electric unit harness connector. Reconnect ABS actuator and electric unit harness connector. Then reset.		
OK	▶	INSPECTION END
NG	▶	Replace ABS actuator and electric unit.

GI
MA
EM
LC
EC
FE
CL
MT
AT
AX
SU
BR
ST
RS
BT
HA
SC
EL
IDX

7. ABS Warning Lamp Stays On When Ignition Switch Is Turned On

=NFBR0144

1	INSPECTION START	
ABS control unit inspection		
		SBR949E
		SBR998E
▶		GO TO 2.

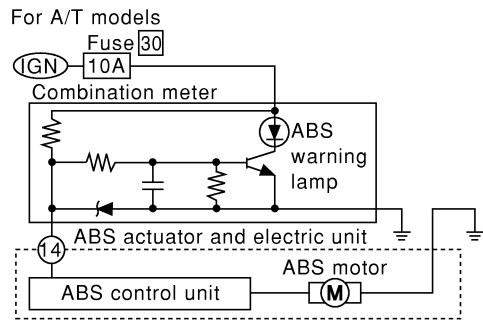
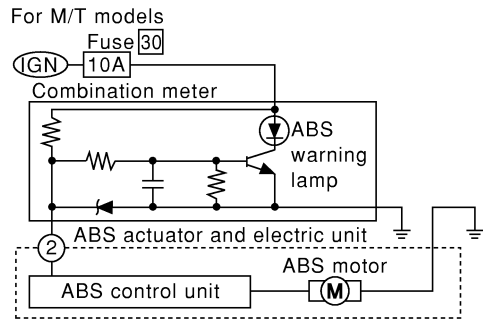

TROUBLE DIAGNOSES FOR SYMPTOMS

ABS

7. ABS Warning Lamp Stays On When Ignition Switch Is Turned On (Cont'd)

2	CHECK WARNING LAMP	
<p>1. Disconnect ABS actuator and electric unit connector.</p> <p>2. Connect suitable wire between ABS actuator and electric unit harness connector E9 for M/T models/E169 for A/T models, terminal 2 (L/R) for M/T models/14 (L/R) for A/T models and ground.</p>		
<p>For M/T models</p> <div style="display: flex; justify-content: center; align-items: center;"> </div> <div style="text-align: center; margin: 10px 0;"> <div style="border: 1px solid black; border-radius: 10px; padding: 5px; width: fit-content; margin: 0 auto;"> ABS ACTUATOR AND ELECTRIC UNIT CONNECTOR </div> </div> <p style="text-align: right; margin-right: 20px;">SBR950EA</p>		
<p>For A/T models</p> <div style="display: flex; justify-content: center; align-items: center;"> </div> <div style="text-align: center; margin: 10px 0;"> <div style="border: 1px solid black; border-radius: 10px; padding: 5px; width: fit-content; margin: 0 auto;"> ABS ACTUATOR AND ELECTRIC UNIT CONNECTOR </div> </div> <p style="text-align: right; margin-right: 20px;">SBR999EA</p>		
Does warning lamp activate?		
Yes	▶	GO TO 3.
No	▶	<p>Repair combination meter. Check the following.</p> <ul style="list-style-type: none"> ● Harness connector E9 for M/T models/14 for A/T models. ● Harness for open or short between ABS actuator and electric unit and fuse <p>If NG, repair harness or connector.</p>

GI
MA
EM
LC
EC
FE
CL
MT
AT
AX
SU
BR

3	CHECK HARNESS CONNECTOR	
<p>Check ABS actuator and electric unit pin terminals for damage or the connection of ABS actuator and electric unit harness connector. Reconnect ABS actuator and electric unit harness connector. Then retest.</p>		
OK	▶	INSPECTION END
NG	▶	GO TO 4.

ST
RS
BT

4	CHECK ABS MOTOR GROUND	
<p>1. Turn ignition switch "OFF".</p> <p>2. Check continuity between ABS motor and ground.</p>		
Does continuity exist?		
Yes	▶	Replace ABS actuator and electric unit.
No	▶	<p>Check the following.</p> <ul style="list-style-type: none"> ● ABS motor ground harness ● ABS motor ground harness for open or short between ABS motor and ground <p>If NG, repair harness.</p>

HA
SC
EL
IDX

Purpose

Purpose

The ABS consists of electronic and hydraulic components. It allows for control of braking force so that locking of the wheels can be avoided. NFBR0048

The ABS:

- 1) Ensures proper tracking performance through steering wheel operation.
- 2) Enables obstacles to be avoided through steering wheel operation.
- 3) Ensures vehicle stability by preventing flat spins.

ABS (Anti-Lock Brake System) Operation

NFBR0049

- When the vehicle speed is less than 10 km/h (6 MPH) this system does not work.
- The Anti-Lock Brake System (ABS) has self-test capabilities. The system turns on the ABS warning lamp for 1 second after turning the ignition switch ON. The system performs another test the first time the vehicle reaches 6 km/h (4 MPH). A mechanical noise may be heard as the ABS performs a self-test. This is a normal part of the self-test feature. If a malfunction is found during this check, the ABS warning lamp will come on.
- During ABS operation, a mechanical noise may be heard. This is a normal condition.

ABS Hydraulic Circuit

NFBR0050

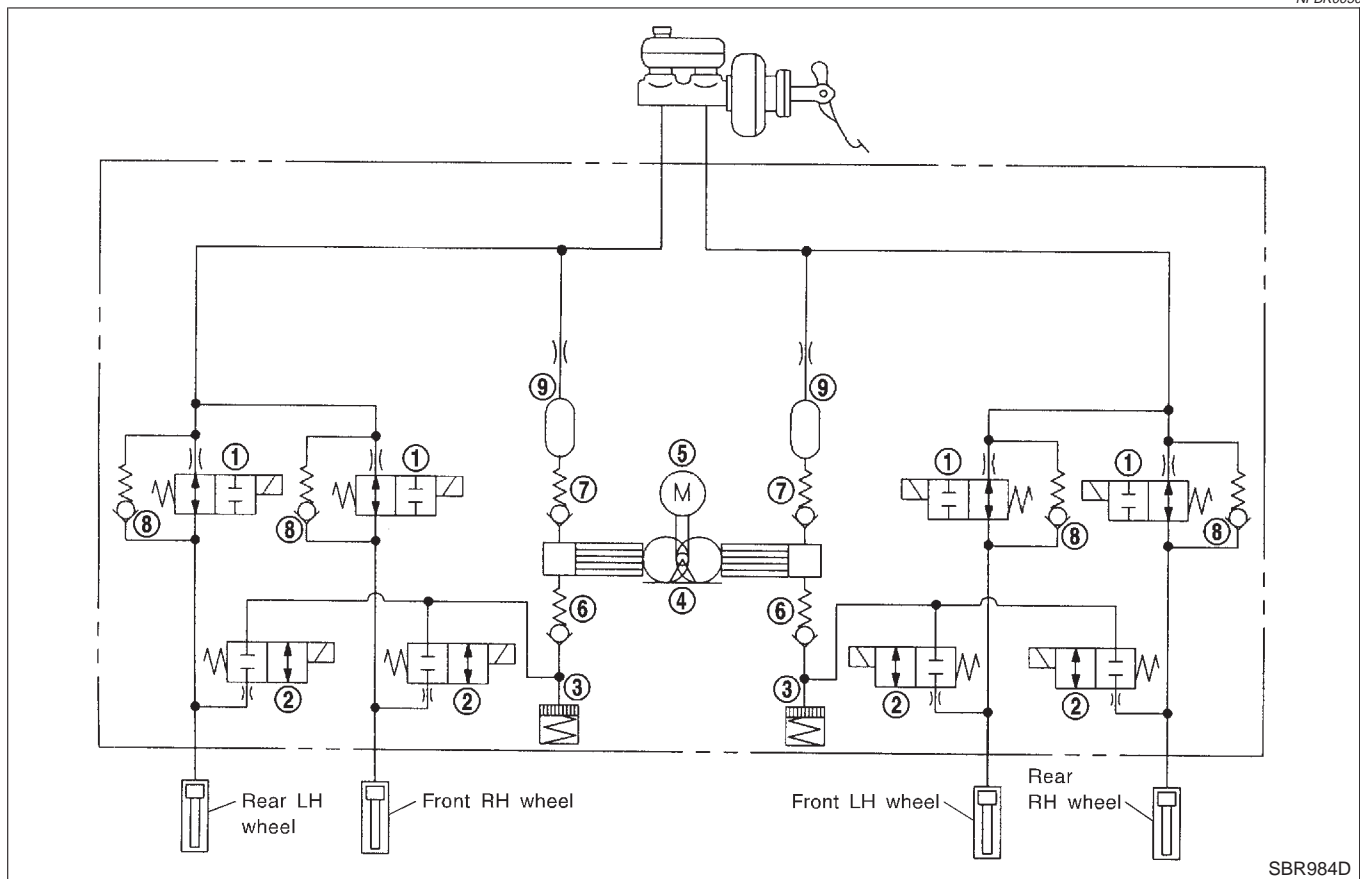

- | | | |
|--------------------------|----------------|-----------------------|
| 1. Inlet solenoid valve | 4. Pump | 7. Outlet valve |
| 2. Outlet solenoid valve | 5. Motor | 8. Bypass check valve |
| 3. Reservoir | 6. Inlet valve | 9. Damper |

TCS (Traction Control System) Operation

=NFBR0145

- This system is designed to limit wheel slip during acceleration by cutting fuel to selected cylinders and changing transmission shift schedule. The ABS/TCS control unit monitors wheel speed slips through the ABS wheel sensors and determines the desired torque reduction needed to minimize wheel spin. The torque reduction by the ABS/TCS control unit may result in a combination of fuel cutoff, throttle control, and change shift timing of the transmission. The torque reduction is sent from the ABS/TCS control unit through the data link to the ECM and TCM. The ECM will cut off fuel and/or close throttle valve little bit, and/or TCM change shift schedule to achieve torque reduction. The TCS will be enabled when the TCS switch is in the ON position (TCS OFF indicator not illuminated), and if the catalytic converter temperature is within normal operating range.
- This system has a self-diagnostic function. When the ignition switch is initially turned "ON", the SLIP indicator lamp and TCS OFF indicator lamp light. If there is no problem with the ABS and TCS, both indicator lamps will go out as soon as the engine starts.
- The TCS OFF switch cancels the TCS function. The TCS OFF indicator lamp then lights to indicate that the TCS is not operating.
- This system utilizes a fuel-cut function to control drive torque. If fuel cut continues for an extended period of time during high-speed operations, the catalyst may melt and deteriorate. During continued TCS operations, the system will sometimes suspend the drive torque control function, preventing catalyst melting and deterioration.

GI
MA
EM
LC
EC
FE
CL

System Components

NFBR0146

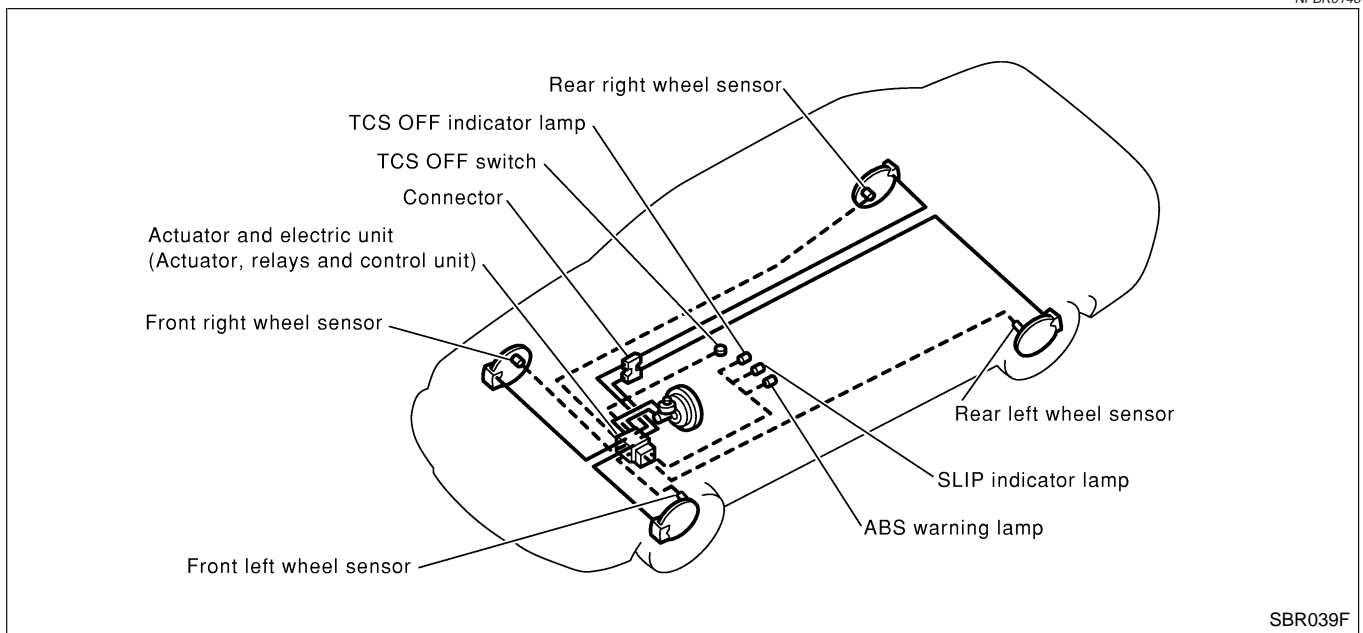

MT
AT
AX
SU
BR
ST
RS
BT

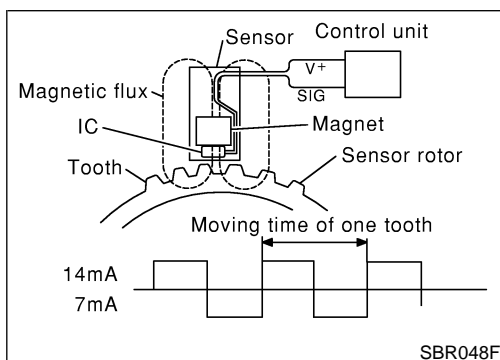

System Description

SENSOR

NFBR0147

NFBR0147S01

The front sensor units consist of a gear-shaped sensor rotor and a sensor element. The element contains a magnet and IC. The front wheel sensors are installed on the front of the wheel knuckles. As the wheel rotates, the sensor generates a square-wave signal. The frequency increase as the wheel speed increases.

SC
EL
IDX

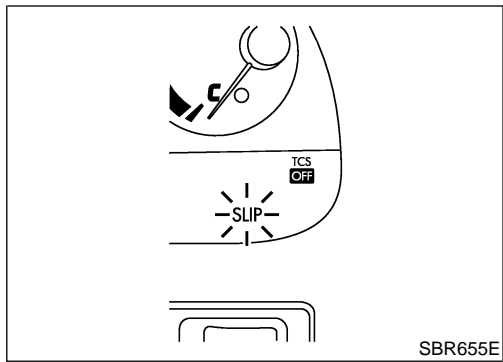

CONTROL UNIT

NFBR0147S02

ABS Function

NFBR0147S0201

The control unit computes the wheel rotating speed by the signal current sent from the sensor. Then it supplies a DC current to the actuator solenoid valve. It also controls ON-OFF operation of the valve relay and motor relay. If any electrical malfunction should be detected in the system, the warning lamp is turned on. In this condition, the ABS will be deactivated, and the vehicle's brake system reverts to normal operation.

TCS Function

NFBR0147S0202

Drive wheel slippage is detected by the 4-wheel rotating speed signal. When the wheel slip becomes excessive, the TCS operates, causing the SLIP indicator lamp to flash. And, at the same time, fuel-cut and throttle opening signals are sent to the ECM and a signal requiring a change in the shift schedule is sent to the TCM. When the TCS OFF switch is used to cancel TCS function, the TCS OFF indicator lamp will light. (TCS does not activate.) In case of a malfunction in the TCS, both the SLIP indicator lamp and the TCS OFF indicator lamp will light, while shutting down the TCS system operation. The vehicle will operate in the same way as a vehicle not equipped with the TCS.

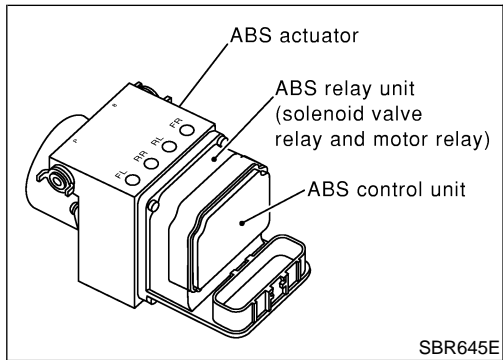

ACTUATOR

NFBR0147S03

The actuator contains:

- An electric motor and pump
- Two relays
- Eight solenoid valves, each inlet and outlet for
 - LH front
 - RH front
 - LH rear
 - RH rear

These components control the hydraulic circuit. The ABS control unit directs the actuator to increase, hold or decrease hydraulic pressure to all or individual wheels.

ABS Actuator Operation

NFBR0147S0301

		Inlet solenoid valve	Outlet solenoid valve	
Normal brake operation		OFF (Open)	OFF (Closed)	Master cylinder brake fluid pressure is directly transmitted to caliper via the inlet solenoid valve.
ABS operation	Pressure hold	ON (Closed)	OFF (Closed)	Hydraulic circuit is shut off to hold the caliper brake fluid pressure.
	Pressure decrease	ON (Closed)	ON (Open)	Caliper brake fluid is sent to reservoir via the outlet solenoid valve. Then it is pushed up to the master cylinder by pump.
	Pressure increase	OFF (Open)	OFF (Closed)	Master cylinder brake fluid pressure is transmitted to caliper.

Component Parts and Harness Connector Location

NFBR0053

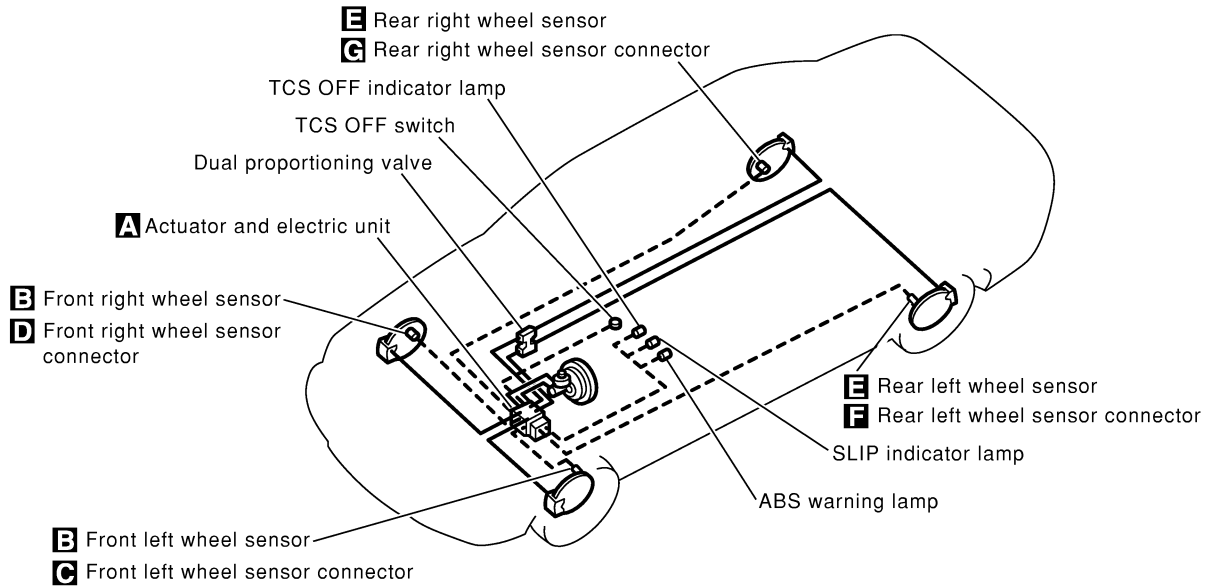

GI
MA
EM
LC
EC
FE
CL
MT
AT
AX
SU
BR
ST
RS
BT
HA
SC
EL
IDX

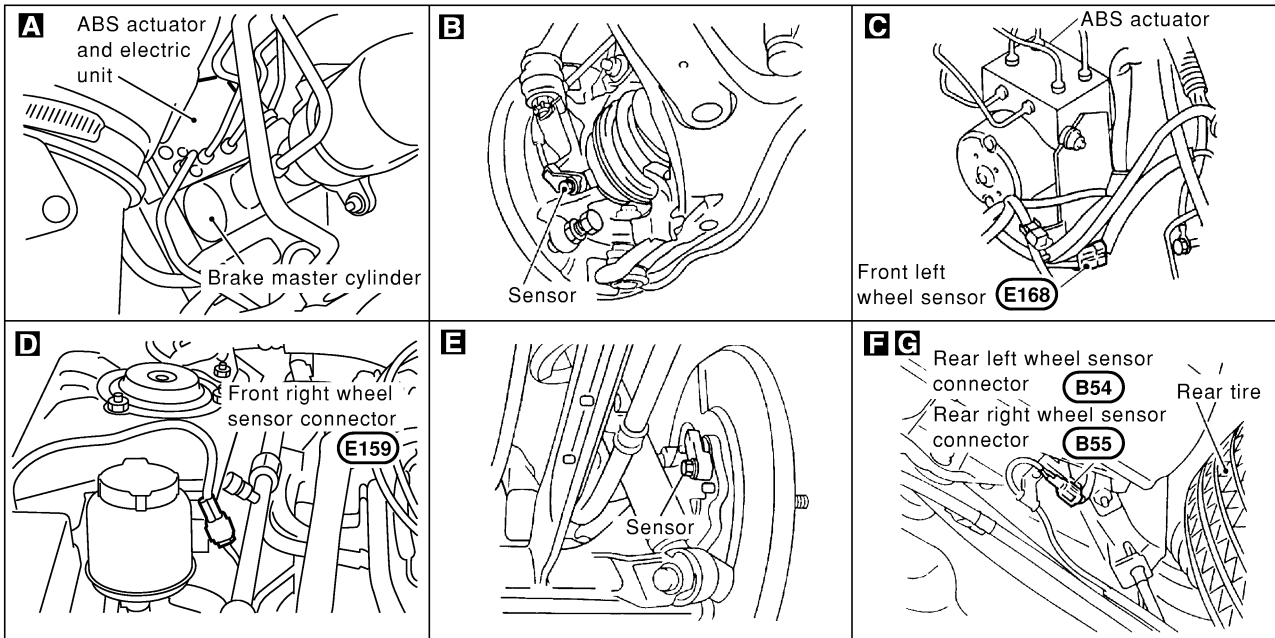

SBR903E

Schematic

NFBR0148

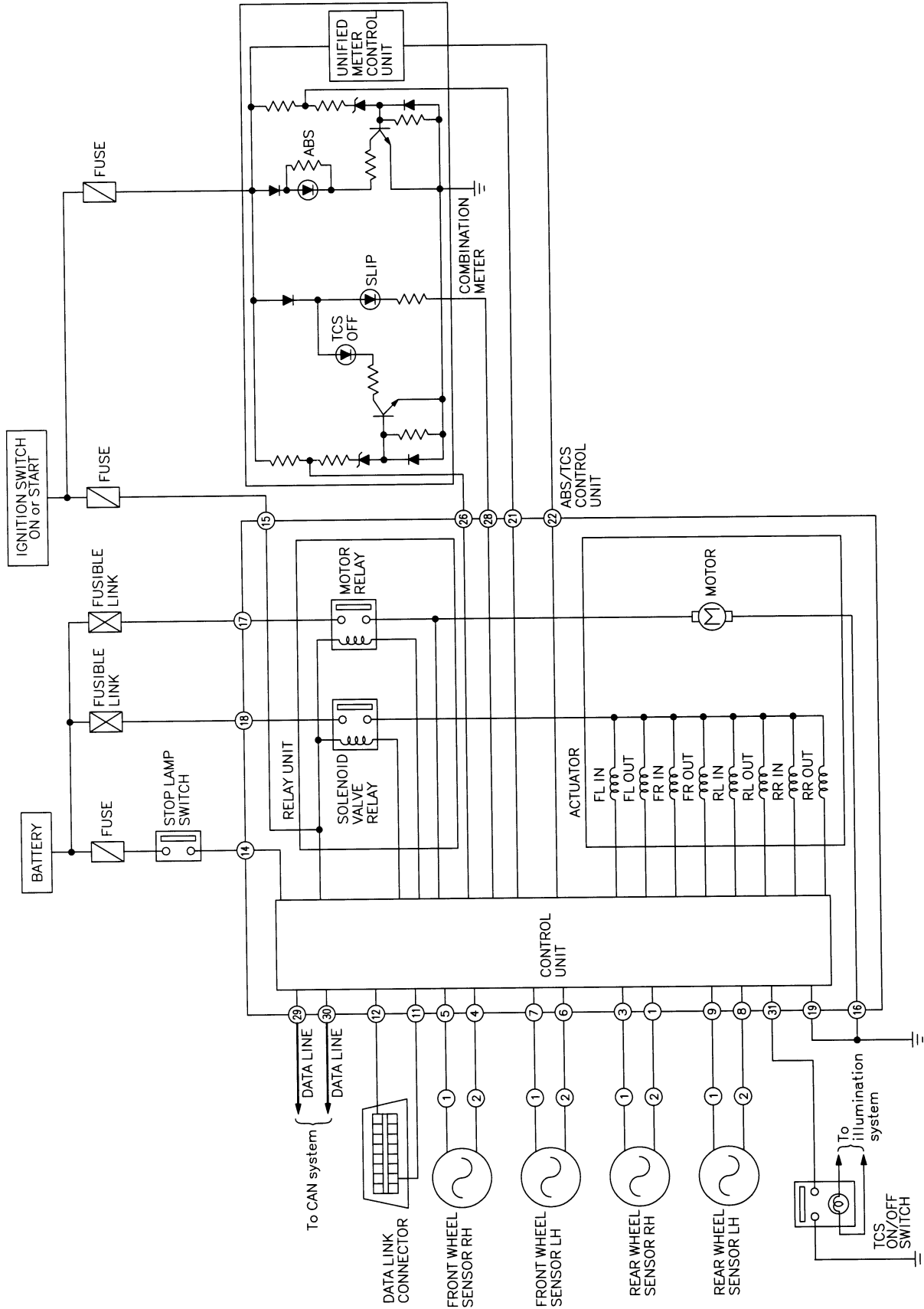

MBR602A

Wiring Diagram — TCS —

NFBR0149

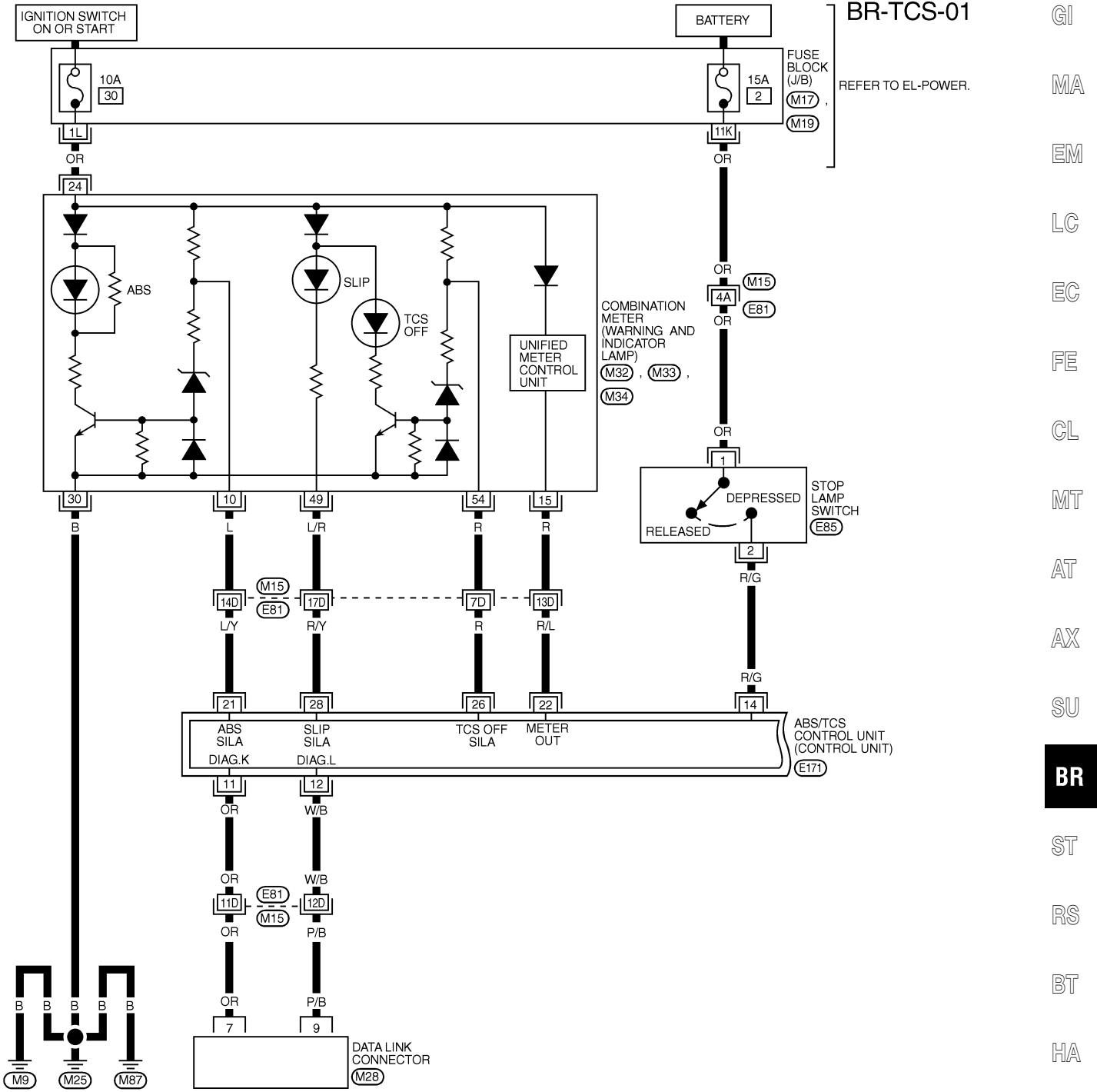

BR-TCS-01

REFER TO EL-POWER.

GI
MA
EM
LC
EC
FE
CL
MT
AT
AX
SU

BR

ST

RS

BT

HA

SC

EL

IDX

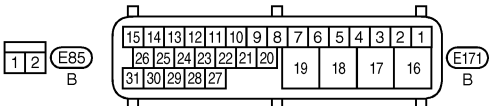
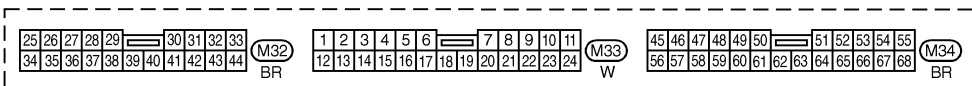
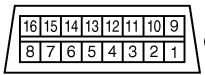

REFER TO THE FOLLOWING.
 (M15) -SUPER
 MULTIPLE JUNCTION (SMJ)
 (M17), (M19) -FUSE BLOCK-
 JUNCTION BOX (J/B)

MBR603A

DESCRIPTION

TCS

Wiring Diagram — TCS — (Cont'd)

BR-TCS-02

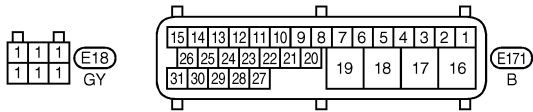
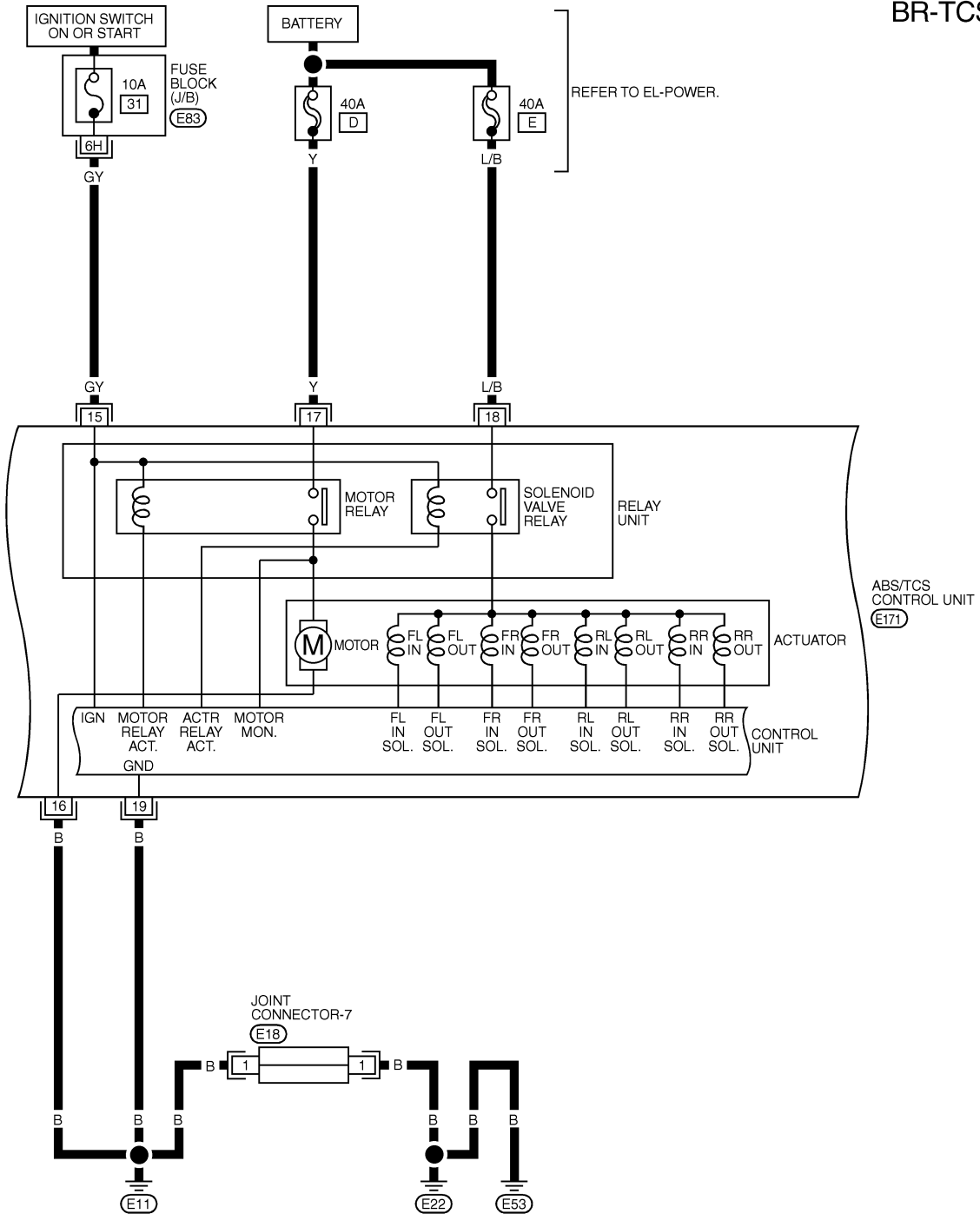

REFER TO THE FOLLOWING.
 (E83) - FUSE BLOCK-JUNCTION BOX (J/B)

MBR515A

DESCRIPTION

TCS

Wiring Diagram — TCS — (Cont'd)

BR-TCS-03

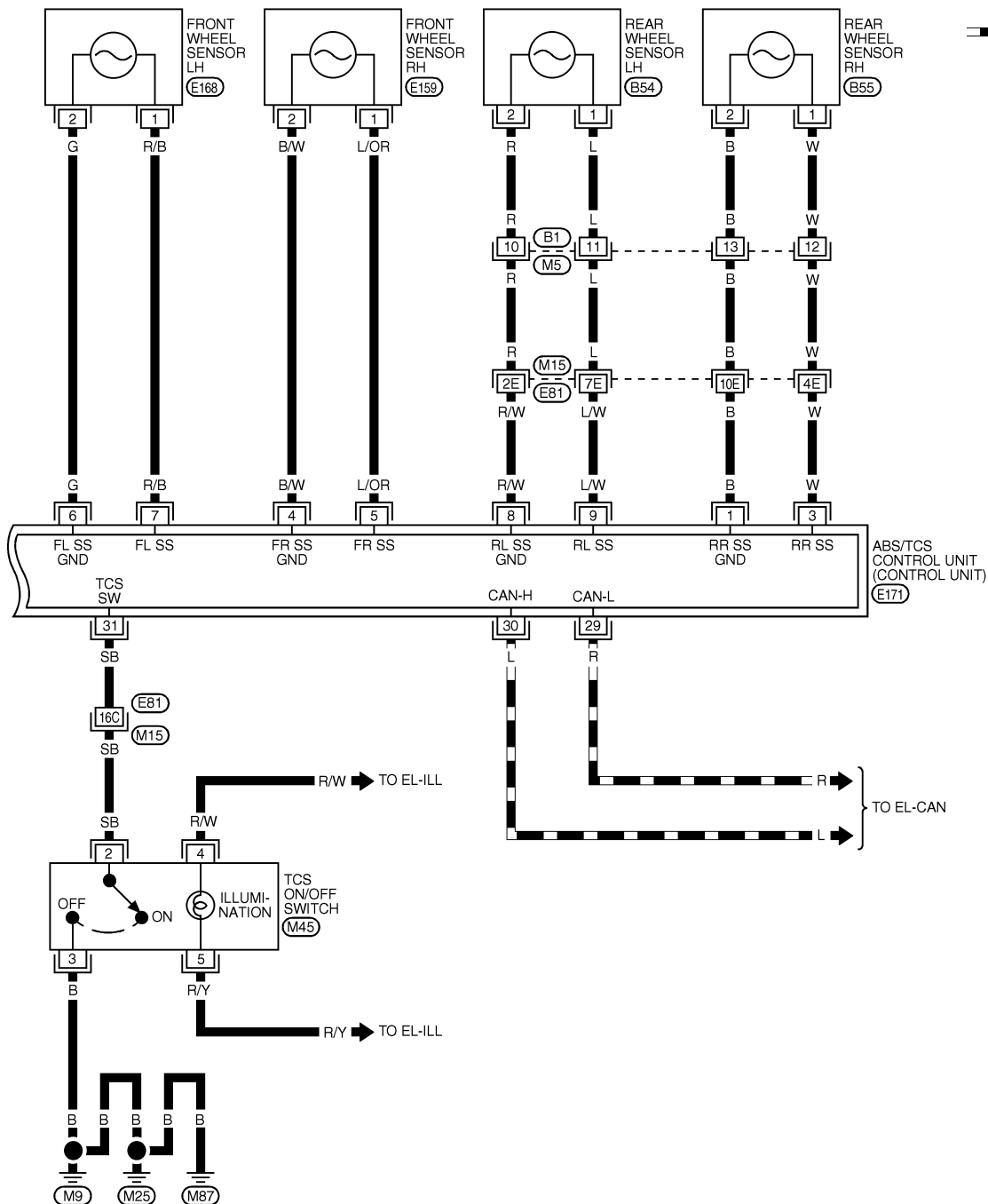

— : DATA LINE

GI
MA
EM
LC
EC
FE
CL
MT
AT
AX
SU
BR
ST
RS
BT
HA
SC
EL
IDX

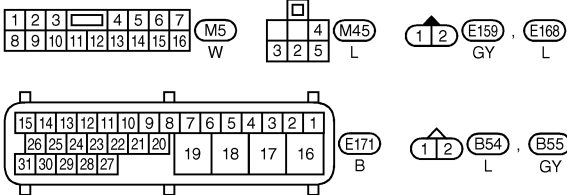

REFER TO THE FOLLOWING.
(M15) - SUPER MULTIPLE JUNCTION (SMJ)

MBR605A

DESCRIPTION

TCS

Wiring Diagram — TCS — (Cont'd)

WIRING DIAGRAM -TCS- (CONT'D)

TERMINAL	WIRE COLOR	ITEM	CONDITION	DATA (DC)
1	B	REAR WHEEL SENSOR RH	WHEN VEHICLE CRUISE AT 30 KM/H (19 MPH)	PULSE FRONT: APPROX. 190 HZ REAR: APPROX. 190 HZ
3	W	REAR WHEEL SENSOR RH		
4	B/W	FRONT WHEEL SENSOR RH		
5	L/OR	FRONT WHEEL SENSOR RH		
6	G	FRONT WHEEL SENSOR LH		
7	R/B	FRONT WHEEL SENSOR LH		
8	R/W	REAR WHEEL SENSOR LH		
9	L/W	REAR WHEEL SENSOR LH		
11	OR	DATA LINK CONNECTOR		
12	W/B	DATA LINK CONNECTOR	-	-
14	R/G	STOP LAMP SWITCH	WHEN BRAKE PEDAL DEPRESSED	BATTERY VOLTAGE
			WHEN BRAKE PEDAL RELEASED	APPROX. 0V
15	GY	POWER SOURCE	IGN ON	BATTERY VOLTAGE
			IGN OFF	APPROX. 0V
16	B	GROUND	-	-
17	Y	POWER SOURCE	-	BATTERY VOLTAGE
18	L/B	POWER SOURCE	-	BATTERY VOLTAGE
19	B	GROUND	-	-
21	L/Y	ABS WARNING LAMP IN	WHEN ABS WARNING LAMP IS ACTIVE	APPROX. 0V
			WHEN ABS WARNING LAMP IS NOT ACTIVE	BATTERY VOLTAGE
22	R/L	UNIFIED METER CONTROL UNIT	-	-
26	R	TCS OFF INDICATOR LAMP IN	WHEN TCS OFF INDICATOR LAMP IS ACTIVE	APPROX. 0V
			WHEN TCS OFF INDICATOR LAMP IS NOT ACTIVE	BATTERY VOLTAGE
28	R/Y	SLIP INDICATOR LAMP	WHEN SLIP INDICATOR LAMP IS ACTIVE	APPROX. 0V
			WHEN SLIP INDICATOR LAMP IS NOT ACTIVE	BATTERY VOLTAGE
29	R	CAN COMMUNICATION INPUT/OUTPUT SIGNAL (L)	IGNITION SWITCH ON	PBIA0224J
30	L	CAN COMMUNICATION INPUT/OUTPUT SIGNAL (H)	IGNITION SWITCH ON	PBIA0223J
31	SB	TCS ON/OFF SWITCH	WHEN TCS OFF SWITCH IS "ON (TCS IS CANCELED)"	APPROX. 0V
			WHEN TCS OFF SWITCH IS "OFF (TCS CAN BE OPERATED)"	APPROX. 4.5V

SBR904E

CONSULT-II

CONSULT-II APPLICATION TO TCS

NFBR0151
NFBR0151S01

ITEM	SELF-DIAGNOSTIC RESULTS	DATA MONITOR	ACTIVE TEST	
Front right wheel sensor	X	X	—	GI
Front left wheel sensor	X	X	—	MA
Rear right wheel sensor	X	X	—	EM
Rear left wheel sensor	X	X	—	LC
ABS sensor	X	—	—	
Stop lamp switch	—	X	—	EC
Front right inlet solenoid valve	X	X	X	
Front right outlet solenoid valve	X	X	X	FE
Front left inlet solenoid valve	X	X	X	
Front left outlet solenoid valve	X	X	X	CL
Rear right inlet solenoid valve	X	X	X	
Rear right outlet solenoid valve	X	X	X	MT
Rear left inlet solenoid valve	X	X	X	
Rear left outlet solenoid valve	X	X	X	AT
Actuator solenoid valve relay	—	X	—	
Actuator motor relay (ABS MOTOR is shown on the ACTIVE TEST screen.)	X	X	X	AX
ABS warning lamp	—	X	—	SU
Battery voltage	X	X	—	BR
Control unit	X	—	—	
Engine speed signal	—	X	—	ST
ABS motor	X	—	X	
A/T gear position signal	—	X	—	RS
TCS OFF indicator lamp	—	X	—	
SLIP indicator lamp	—	X	—	BT
CAN communication	X	X	—	

X: Applicable

—: Not applicable

ECU (ABS/TCS CONTROL UNIT) PART NUMBER MODE

NFBR0151S02

Ignore the ECU part number displayed in the ECU PART NUMBER MODE. Refer to parts catalog to order the ECU.

GI

MA

EM

LC

EC

FE

CL

MT

AT

AX

SU

BR

ST

RS

BT

HA

SC

EL

IDX

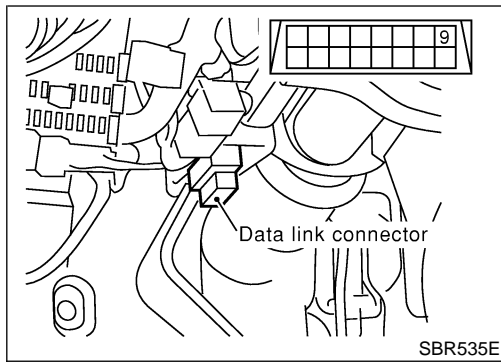

CONSULT-II Inspection Procedure SELF-DIAGNOSIS PROCEDURE

NFBR0152

NFBR0152S01

1. Turn ignition switch OFF.
2. Connect CONSULT-II to Data Link Connector.
3. Start engine.
4. Drive vehicle over 30 km/h (19 MPH) for at least one minute.
5. Stop vehicle with engine running and touch "START" on CONSULT-II screen.

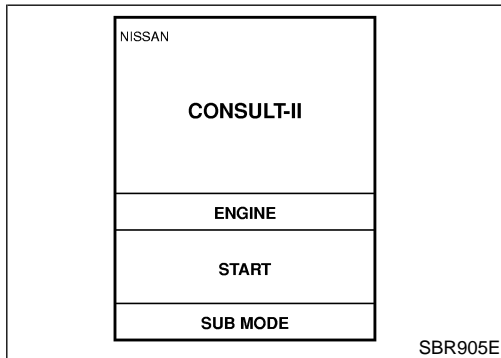

6. Touch "ABS".

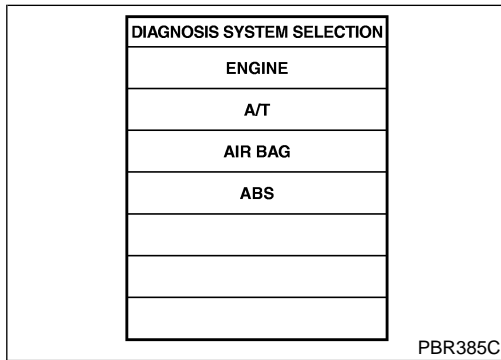

7. Touch "SELF DIAGNOSIS RESULTS".
 - The screen shows the detected malfunction and how many times the ignition switch has been turned since the malfunction.
8. Make the necessary repairs following the diagnostic procedures.

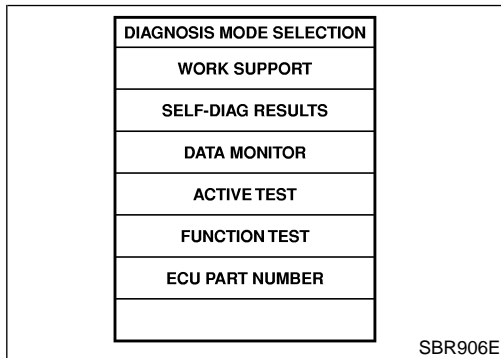

9. After the malfunctions are repaired, erase the self-diagnostic results stored in the control unit by touching "ERASE".
10. Check ABS warning lamp, SLIP indicator lamp, TCS OFF indicator lamp for deactivation after driving vehicle over 30 km/h (19 MPH) for at least one minute.

NOTE:

"SELF-DIAG RESULTS" screen shows the detected malfunction and how many times the ignition switch has been turned since the malfunction.

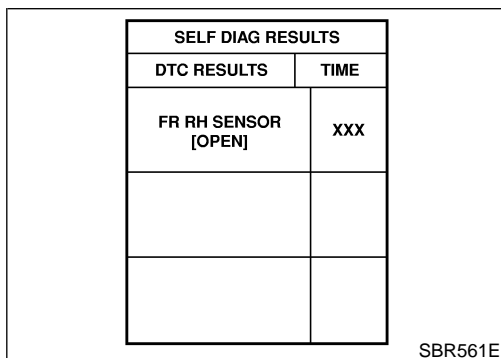

ON BOARD DIAGNOSTIC SYSTEM DESCRIPTION

TCS

CONSULT-II Inspection Procedure (Cont'd)

SELF-DIAGNOSTIC RESULTS MODE

=NFBR0152S02

Diagnostic item	Diagnostic item is detected when ...	Reference Page	
FR RH SENSOR-1	<ul style="list-style-type: none"> ● Circuit for front right wheel sensor is open. (An abnormally high input voltage is entered.) 	BR-110	GI
FR LH SENSOR-1	<ul style="list-style-type: none"> ● Circuit for front left wheel sensor is open. (An abnormally high input voltage is entered.) 	BR-110	MA
RR RH SENSOR-1	<ul style="list-style-type: none"> ● Circuit for rear right sensor is open. (An abnormally high input voltage is entered.) 	BR-110	EM
RR LH SENSOR-1	<ul style="list-style-type: none"> ● Circuit for rear left sensor is open. (An abnormally high input voltage is entered.) 	BR-110	LC
FR RH SENSOR-2	<ul style="list-style-type: none"> ● Circuit for front right wheel sensor is shorted. (An abnormally low input voltage is entered.) 	BR-110	EC
FR LH SENSOR-2	<ul style="list-style-type: none"> ● Circuit for front left wheel sensor is shorted. (An abnormally low input voltage is entered.) 	BR-110	FE
RR RH SENSOR-2	<ul style="list-style-type: none"> ● Circuit for rear right sensor is shorted. (An abnormally low input voltage is entered.) 	BR-110	CL
RR LH SENSOR-2	<ul style="list-style-type: none"> ● Circuit for rear left sensor is shorted. (An abnormally low input voltage is entered.) 	BR-110	MT
ABS SENSOR [ABNORMAL SIGNAL]	<ul style="list-style-type: none"> ● Teeth damage on sensor rotor or improper installation of wheel sensor. (Abnormal wheel sensor signal is entered.) 	BR-110	AT
FR RH IN ABS SOL	<ul style="list-style-type: none"> ● Circuit for front right inlet solenoid valve is open. (An abnormally low output voltage is entered.) 	BR-114	AX
FR LH IN ABS SOL	<ul style="list-style-type: none"> ● Circuit for front left inlet solenoid valve is open. (An abnormally low output voltage is entered.) 	BR-114	SU
RR RH IN ABS SOL	<ul style="list-style-type: none"> ● Circuit for rear right inlet solenoid valve is open. (An abnormally low output voltage is entered.) 	BR-114	BR
RR LH IN ABS SOL	<ul style="list-style-type: none"> ● Circuit for rear left inlet solenoid valve is open. (An abnormally low output voltage is entered.) 	BR-114	ST
FR RH OUT ABS SOL	<ul style="list-style-type: none"> ● Circuit for front right outlet solenoid valve is open. (An abnormally low output voltage is entered.) 	BR-114	RS
FR LH OUT ABS SOL	<ul style="list-style-type: none"> ● Circuit for front left outlet solenoid valve is open. (An abnormally low output voltage is entered.) 	BR-114	BT
RR RH OUT ABS SOL	<ul style="list-style-type: none"> ● Circuit for rear right outlet solenoid valve is open. (An abnormally low output voltage is entered.) 	BR-114	HA
RR LH OUT ABS SOL	<ul style="list-style-type: none"> ● Circuit for rear left outlet solenoid valve is open. (An abnormally low output voltage is entered.) 	BR-114	SC
ABS ACTUATOR RELAY [ABNORMAL]	<ul style="list-style-type: none"> ● Actuator solenoid valve relay is ON, even control unit sends off signal. ● Actuator solenoid valve relay is OFF, even control unit sends on signal. 	BR-114	EL
PUMP MOTOR	<ul style="list-style-type: none"> ● Circuit for actuator motor is open or shorted. ● Actuator motor relay is stuck. 	BR-117	IDX
BATTERY VOLTAGE [ABNORMAL]	<ul style="list-style-type: none"> ● Power source voltage supplied to ABS/TCS control unit is abnormally low or high. 	BR-119	
CONTROLLER FAILURE	<ul style="list-style-type: none"> ● Function of calculation in ABS/TCS control unit has failed. 	BR-121	
FR LH IN ABS SOL	<ul style="list-style-type: none"> ● Circuit of the front LH wheel inlet solenoid valve is open or short, or the control line is open or short to the power supply or the ground. 	BR-114	
FR LH OUT ABS SOL	<ul style="list-style-type: none"> ● Circuit of the front LH wheel outlet solenoid valve is open or short, or the control line is open or short to the power supply or the ground. 	BR-114	

Diagnostic item	Diagnostic item is detected when ...	Reference Page
RR RH IN ABS SOL	<ul style="list-style-type: none"> • Circuit of the front LH wheel inlet solenoid valve is open or short, or the control line is open or short to the power supply or the ground. 	BR-114
RR RH OUT ABS SOL	<ul style="list-style-type: none"> • Circuit of the front LH wheel outlet solenoid valve is open or short, or the control line is open or short to the power supply or the ground. 	BR-114
FR RH IN ABS SOL	<ul style="list-style-type: none"> • Circuit of the front LH wheel inlet solenoid valve is open or short, or the control line is open or short to the power supply or the ground. 	BR-114
FR RH OUT ABS SOL RR LH IN ABS SOL RR LH OUT ABS SOL	<ul style="list-style-type: none"> • Circuit of the front LH wheel outlet solenoid valve is open or short, or the control line is open or short to the power supply or the ground. 	BR-114
ENGINE SIGNAL 1, 2, 3, 4	Engine related part has malfunction.	EC-141
CAN COMM CIRCUIT*2	<ul style="list-style-type: none"> • CAN communication line is open or short. • TCS/ABS control unit internal malfunction. • Power supply for ECM is interrupted instantaneously for approx. 0.5 seconds or more. 	EL-437
A/T SIGNAL	CAN communication with TCM is not normal.	AT-208

*1: When “## ## SENSOR 2” is displayed, check power supply for TCS/ABS control unit in addition to wheel sensor circuit.

*2: When any diagnosis results is detected with “CAN COMM CIRCUIT” CAN communication circuit first.

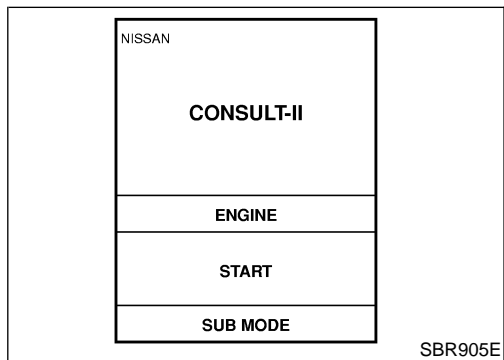

DATA MONITOR PROCEDURE

NFBR0152S03

1. Turn ignition switch OFF.
2. Connect CONSULT-II to data link connector.
3. Turn ignition switch ON.
4. Touch “START” on CONSULT-II screen.

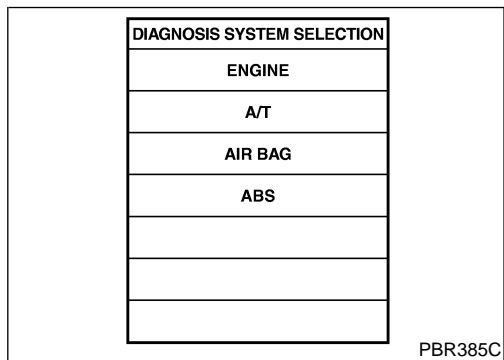

5. Touch “ABS”.

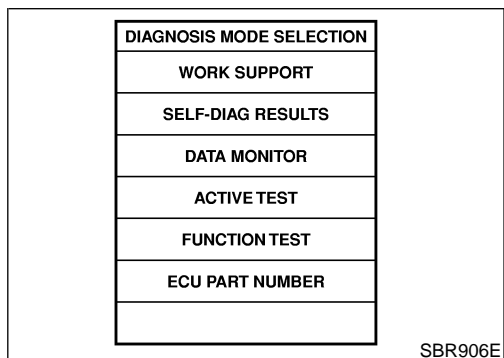

6. Touch “DATA MONITOR”.
7. Touch “SETTING” on “SELECT MONITOR ITEM” screen.
8. Touch “START” on “SELECT MONITOR ITEM”.

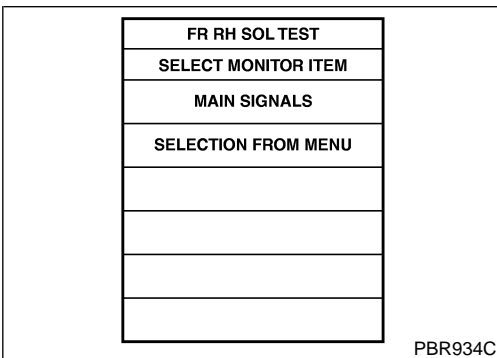
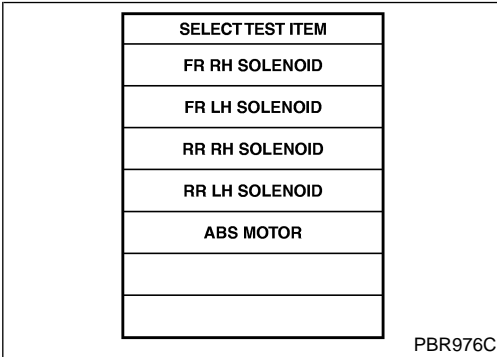
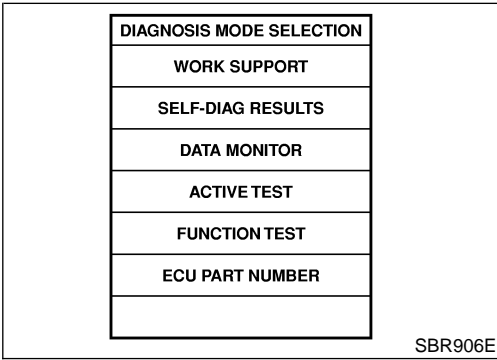
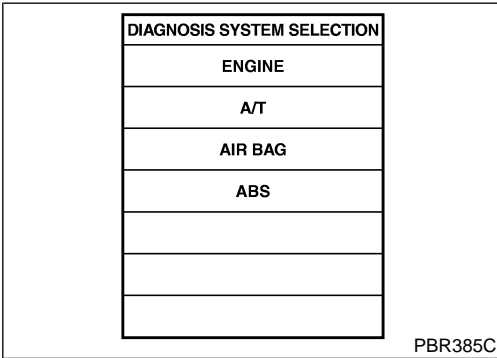
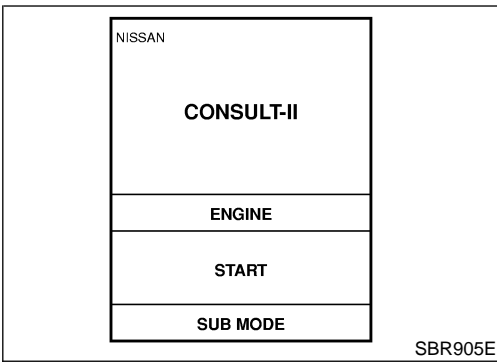

ACTIVE TEST PROCEDURE

NFBR0152S04

- When conducting Active test, vehicle must be stationary.
 - When ABS warning lamp or SLIP indicator lamp stays on, never conduct Active test.
1. Turn ignition switch OFF.
 2. Connect CONSULT-II to Data Link Connector.
 3. Start engine.
 4. Touch "START" on CONSULT-II screen.
 5. Touch "ABS".
 6. Touch "ACTIVE TEST".
 7. Select active test item by touching screen.
 8. Touch "START".
 9. Carry out the active test by touching screen key.

GI
MA
EM
LC
EC
FE
CL
MT
AT
AX
SU
BR
ST
RS
BT
HA
SC
EL
IDX

ON BOARD DIAGNOSTIC SYSTEM DESCRIPTION

TCS

CONSULT-II Inspection Procedure (Cont'd)

DATA MONITOR MODE

NFBR0152S05

MONITOR ITEM	CONDITION	SPECIFICATION
FR RH SENSOR FR LH SENSOR RR RH SENSOR RR LH SENSOR	Drive vehicle. (Each wheel is rotating.)	Displays computed vehicle speed from wheel sensor signal. Almost the same speed as speedometer.
STOP LAMP SW	Turn ignition switch ON and depress brake pedal.	Depress the pedal: ON Release the pedal: OFF
ENGINE SPEED	Engine is running. (rpm)	Engine speed: 0 - 12,800 (rpm)
FR RH IN SOL FR RH OUT SOL FR LH IN SOL FR LH OUT SOL RR RH IN SOL RR RH OUT SOL RR LH IN SOL RR LH OUT SOL	Ignition switch is turned ON or engine is running.	Operating conditions for each solenoid valve are indicated. ABS is not operating: OFF
ACTUATOR RLY	Ignition switch is turned ON or engine is running.	Displays ON/OFF condition of ABS actuator relay. When turning ignition switch ON, ABS actuator relay is operated.
MOTOR RELAY		ABS is not operating: OFF ABS is operating: ON
ABS WARN LAMP		Warning lamp is turned on: ON Warning lamp is turned off: OFF
BATTERY VOLT		Power supply voltage for control unit
GEAR	A/T gear position signal detected by TCM is displayed.	Gear position: 1st: 1 2nd: 2 3rd: 3 4th: 4
NEXT GR POSI	A/T next gear position is displayed.	Gear position: 1st: 1 2nd: 2 3rd: 3 4th: 4
OFF SW	ON/OFF condition of signal from TCS switch is displayed.	TCS OFF S/W (all the time switch is pressed): ON TCS OFF S/W (released): OFF
OFF LAMP	<ul style="list-style-type: none"> ● TCS OFF condition is displayed. ● The condition of malfunctioning TCS is displayed. 	TCS OFF indicator "OFF": OFF TCS OFF indicator "ON": ON
SLIP LAMP	The TCS functioning state is displayed by detecting rear wheel slip.	SLIP indicator "ON": ON SLIP indicator "OFF": OFF
CAN COMM	CAN communication signal status is displayed.	In normal communication: OK In improper communication: NG
CAN CIRC1	CAN communication signal status is displayed.	In normal signal sending: OK In improper signal sending: UNKWN
CAN CIRC2	CAN communication signal status is displayed.	In normal communication with ECM: OK In improper communication with ECM: UNKWN
CAN CIRC3	CAN communication signal status is displayed.	In normal communication with TCM: OK In improper communication with TCM: UNKWN

ON BOARD DIAGNOSTIC SYSTEM DESCRIPTION

TCS

CONSULT-II Inspection Procedure (Cont'd)

MONITOR ITEM	CONDITION	SPECIFICATION	
SLCT LVR POSI	Shift lever position detected through TCM is displayed.	1st: 1 2nd: 2 3rd: 3 4th: 4 D range: D N range: N R range: R P range: P	GI MA EM

ACTIVE TEST MODE

NFBR0152S06

TEST ITEM	CONDITION	JUDGEMENT			
FR RH SOL FR LH SOL RR RH SOL RR LH SOL	Ignition switch is turned ON.	Brake fluid pressure control operation			EC
			IN SOL	OUT SOL	
		UP (Increase):	OFF	OFF	FE
		KEEP (Hold):	ON	OFF	
		DOWN (Decrease):	ON	ON*	CL
ABS MOTOR		ABS actuator motor ON: Motor runs OFF: Motor stops			MT

NOTE:

Active test will automatically stop ten seconds after the test starts. (TEST IS STOPPED monitor shows ON.)

*: "ON" lasts for 1 to 2 seconds after touching screen, then it goes to "OFF".

GI
MA
EM
LC
EC
FE
CL
MT
AT
AX
SU
BR
ST
RS
BT
HA
SC
EL
IDX

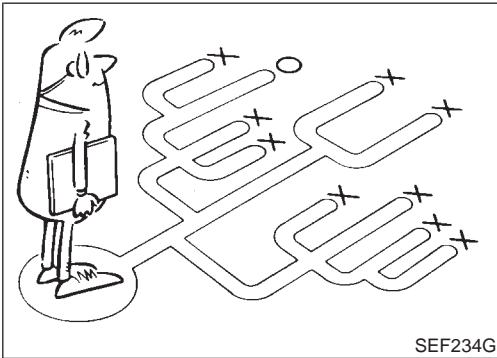
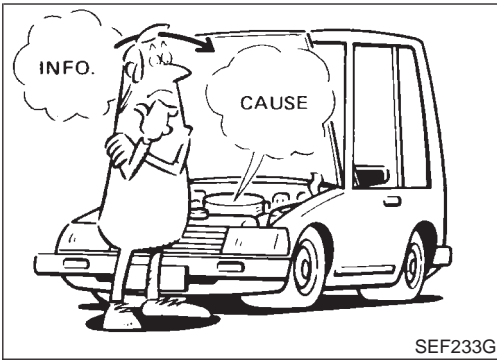

How to Perform Trouble Diagnoses for Quick and Accurate Repair

INTRODUCTION

NFBR0153

NFBR0153S01

The ABS/TCS system has an electronic control unit to control major functions. The control unit accepts input signals from sensors and instantly drives actuator. It is essential that both kinds of signals are proper and stable. It is also important to check for conventional problems: such as air leaks in the booster or lines, lack of brake fluid, or other problems with the brake system.

It is much more difficult to diagnose a problem that occurs intermittently rather than continuously. Most intermittent problems are caused by poor electric connections or faulty wiring. In this case, careful checking of suspicious circuits may help prevent the replacement of good parts.

A visual check only may not find the cause of the problems, so a road test should be performed.

Before undertaking actual checks, take just a few minutes to talk with a customer who approaches with an ABS/TCS complaint. The customer is a very good source of information on such problems; especially intermittent ones. Through the talks with the customer, find out what symptoms are present and under what conditions they occur.

Start your diagnosis by looking for “conventional” problems first. This is one of the best ways to troubleshoot brake problems on an ABS/TCS controlled vehicle. Also check related Service Bulletins for information.

Preliminary Check

NFBR0155

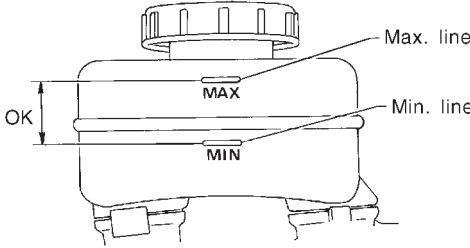
1	CHECK BRAKE FLUID LEVEL		
		<p>Check brake fluid level in reservoir tank. Low fluid level may indicate brake pad wear or leakage from brake line.</p> <div style="text-align: center;">  </div> <p style="text-align: right;">SBR451D</p>	<p>GI</p> <p>MA</p> <p>EM</p> <p>LC</p> <p>EC</p> <p>FE</p> <p>CL</p>
		<p>Is brake fluid filled between MAX and MIN lines on reservoir tank and/or has brake fluid been contaminated?</p>	
Yes		▶ GO TO 2.	
No		▶ Repair. GO TO 2.	

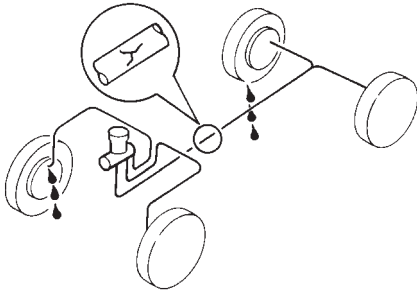
2	CHECK BRAKE LINE		
		<p>Check brake line for leakage.</p> <div style="text-align: center;">  </div> <p style="text-align: right;">SBR389C</p>	<p>MT</p> <p>AT</p> <p>AX</p> <p>SU</p> <p>BR</p> <p>ST</p> <p>RS</p> <p>BT</p> <p>HA</p> <p>SC</p> <p>EL</p> <p>IDX</p>
		<p>Is leakage present at or around brake lines, tubes or hoses or are any of these parts cracked or damaged?</p>	
Yes		▶ Repair. GO TO 3.	
No		▶ GO TO 3.	

Preliminary Check (Cont'd)

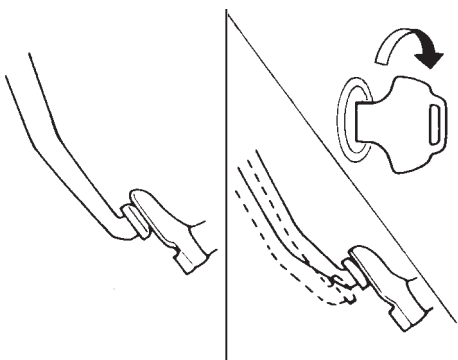
3	CHECK BRAKE BOOSTER OPERATION	
<p>Check brake booster for operation and air tightness. Refer to BR-20.</p> <div style="text-align: center;">  </div> <p style="text-align: right;">SBR058C</p>		
Is brake booster airtight and functioning properly?		
Yes	▶	GO TO 4.
No	▶	Replace. GO TO 4.

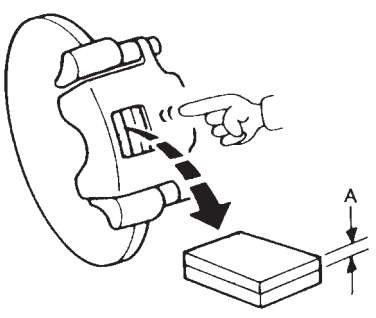
4	CHECK BRAKE PAD AND ROTOR	
<p>Check brake pad and rotor. Refer to BR-23, 25, 27, 31.</p> <div style="text-align: center;">  </div> <p style="text-align: right;">SBR059C</p>		
Are brake pads and rotors functioning properly?		
Yes	▶	GO TO 5.
No	▶	Replace.

5	RECHECK BRAKE FLUID LEVEL	
Check brake fluid level in reservoir tank again.		
SBR451D		
Is brake fluid filled between MAX and MIN lines on reservoir tank and/or has brake fluid been contaminated?		
Yes	▶	GO TO 6.
No	▶	Fill up brake fluid.

GI
MA
EM
LC
EC
FE
CL

6	CHECK WARNING LAMP ACTIVATION	
Check warning lamp activation.		
SBR655E		
Does warning lamp turn on when ignition switch is turned "ON"?		
Yes	▶	GO TO 7.
No	▶	Check fuse, warning lamp bulb and warning lamp circuit.

MT
AT
AX
SU

BR

7	CHECK WARNING LAMP DEACTIVATION	
Check warning lamp for deactivation after engine is started.		
Does warning lamp turn off when engine is started?		
Yes	▶	GO TO 8.
No	▶	Go to Self-diagnosis. Refer to BR-96.

RS
BT
HA

8	DRIVE VEHICLE	
Drive vehicle at speeds over 30 km/h (19 MPH) for at least one minute.		
Does warning lamp remain off after vehicle has been driven at 30 km/h (19 MPH) for at least one minute?		
Yes	▶	END
No	▶	Go to Self-diagnosis. Refer to BR-96.

SC
EL
IDX

Ground Circuit Check

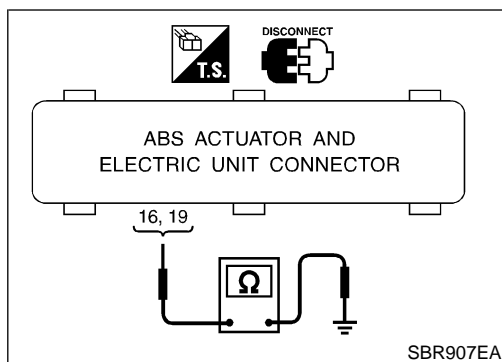
**Ground Circuit Check****ABS ACTUATOR AND ELECTRIC UNIT GROUND**

NFBR0157

NFBR0157S01

- Check continuity between ABS actuator and electric unit harness connector E171 terminals 16 (B), 19 (B) and ground.

Continuity should exist.

Malfunction Code/Symptom Chart

NFBR0158

Code No. (FAIL CODE No.)	Malfunctioning part	Warning lamp	Indicator		Fail-safe	Reference Page
			ABS	TCS OFF		
U1000	CAN communication system failure	ON or OFF	ON	ON	X	BR-122
C1101	Rear right sensor (open-circuit)	ON	ON	ON	X	BR-110
C1102	Rear left sensor (open-circuit)	ON	ON	ON	X	BR-110
C1103	Front right sensor (open-circuit)	ON	ON	ON	X	BR-110
C1104	Front left sensor (open-circuit)	ON	ON	ON	X	BR-110
C1105	Rear right sensor (short-circuit)*2	ON	ON	ON	X	BR-110
C1106	Rear left sensor (short-circuit)*2	ON	ON	ON	X	BR-110
C1107	Front right sensor (short-circuit)*2	ON	ON	ON	X	BR-110
C1108	Front left sensor (short-circuit)*2	ON	ON	ON	X	BR-110
C1109	Power supply (Low or high voltage)	ON	ON	ON	—*1	BR-119
C1110	Control unit	ON	ON	ON	X	BR-121
C1111	Actuator motor or motor relay	ON	ON	ON	X	BR-117
C1114	Solenoid valve relay	ON	ON	ON	X	BR-114
C1120	Actuator front left inlet solenoid valve	ON	ON	ON	X	BR-114
C1121	Actuator front left outlet solenoid valve	ON	ON	ON	X	BR-114
C1122	Actuator front right inlet solenoid valve	ON	ON	ON	X	BR-114
C1123	Actuator front right outlet solenoid valve	ON	ON	ON	X	BR-114
C1124	Actuator rear left inlet solenoid valve	ON	ON	ON	X	BR-114
C1125	Actuator rear left outlet solenoid valve	ON	ON	ON	X	BR-114
C1126	Actuator rear right inlet solenoid valve	ON	ON	ON	X	BR-114
C1127	Actuator rear right outlet solenoid valve	ON	ON	ON	X	BR-114
C1130	CAN communication line or ECM*4	—*3	X	X	X	BR-122
C1131	CAN communication line or ECM*4	—*3	X	X	X	BR-122
C1132	CAN communication line or ECM*4	—*3	X	X	X	BR-122
C1133	CAN communication line or ECM*4	—*3	X	X	X	BR-122
C1135	CAN communication line or TCM*5	—*3	X	X	X	BR-122
C1155	Wheel sensor or the circuit	X	X	X	X	BR-110

X: Available —: Not available

*1: Fail-safe operation does not activate. A signal from control unit suspends TCS and ABS control operation. Brakes operate conventionally. After specified power supply voltage resumes, TCS OFF and SLIP indicator and ABS warning lamp go out, allowing for TCS and ABS control operation.

*2: If a wheel or wheels spin on bad or slippery road surfaces for a period of approximately 10 to 80 seconds, the ABS warning lamp and the TCS OFF indicator lamp light. But this is not a malfunction. When the ignition switch is turned "ON" after a shorted wheel sensor circuit has been repaired, the ABS warning lamp and the TCS OFF indicator lamp light. Drive the vehicle at about 30 km/h (19 MPH) to ensure these lamps go out within 1 minute.

*3: TCS control stops due to fail safe operation, however ABS keeps operation.

*4: For more detail, refer to BR-122.

*5: For more detail, refer to BR-123.

Malfunction Code/Symptom Chart (Cont'd)

NOTE:

When a system part have electric malfunction, ABS warning lamp is illuminated by fail safe function. According to malfunctioning condition, both ABS and EBD system become in following conditions.

- 1) ABS is not operated. EBD is operated.
- 2) Both ABS and EBD are operated. (Same condition as the vehicle without ABS and EBD)

On the condition 1), some sound for ABS system self diagnosis can be heard same as usual, when kye smith is turned ON or first starting.

System Description

NFBR0209

CAN (Controller Area Network) is a serial communication line for real time application. It is an on-vehicle multiplex communication line with high data communication speed and excellent error detection ability. Many electronic control units are equipped onto a vehicle, and each control unit shares information and links with other control units during operation (not independent). In CAN communication, control units are connected with 2 communication lines (CAN H line, CAN L line) allowing a high rate of information transmission with less wiring. Each control unit transmits/receives data but selectively reads required data only.

FOR A/T MODELS

System Diagram

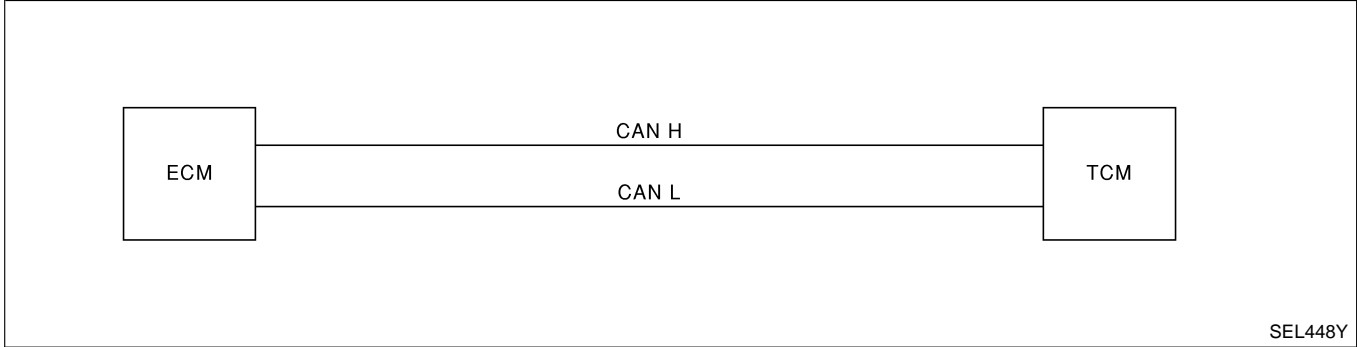
NFBR0209S01
NFBR0209S0101

SEL448Y

Input/Output Signal Chart

T: Transmit R: Receive

NFBR0209S0102

Signals	ECM	TCM
Accelerator pedal position signal	T	R
Output shaft revolution signal	R	T

FOR TCS MODELS

System Diagram

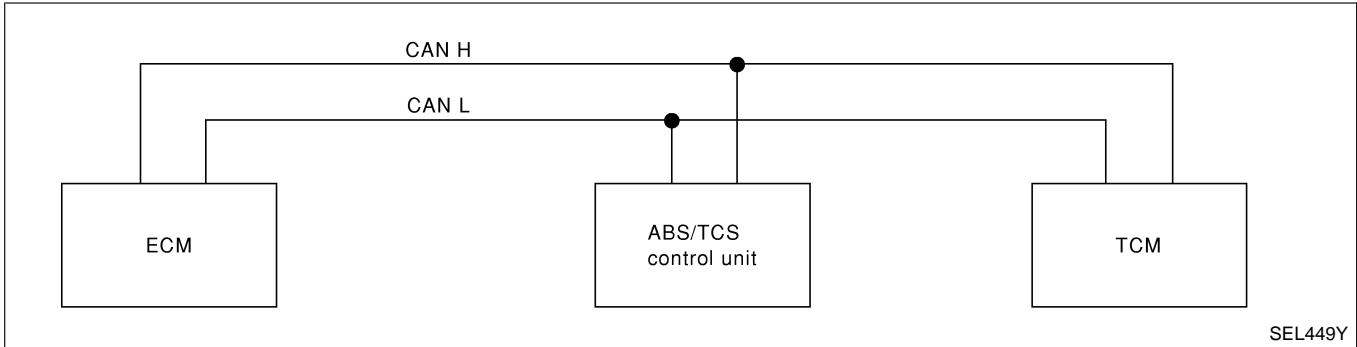
NFBR0209S02
NFBR0209S0201

SEL449Y

Input/Output Signal Chart

T: Transmit R: Receive

NFBR0209S0202

Signals	ECM	ABS/TCS control unit	TCM
Accelerator pedal position signal	T	R	R
Output shaft revolution signal	R		T

GI
 MA
 EM
 LC
 EC
 FE
 CL
 MT
 AT
 AX
 SU
BR
 ST
 RS
 BT
 HA
 SC
 EL
 IDX

Wheel Sensor or Rotor DIAGNOSTIC PROCEDURE

NFB0159

NFB0159S01

1	INSPECTION START
Wheel sensor inspection	
SBR046F	
▶	GO TO 2.

2	CHECK CONNECTOR
1. Disconnect connectors from control unit and wheel sensor of malfunction code No. Check terminals for damage or loose connections. Then reconnect connectors. 2. Carry out self-diagnosis again.	
Does warning lamp activate again?	
Yes	▶ GO TO 3.
No	▶ INSPECTION END

3	CHECK WHEEL SENSOR CIRCUIT
1. Disconnect control unit connector. 2. Check resistance between control unit connector terminals.	
Front RH wheel Terminals 4 (B/W) and 5 (L/OR)	
Front LH wheel Terminals 6 (G) and 7 (R/B)	
Rear RH wheel Terminals 1 (B) and 3 (W)	
Rear LH wheel Terminals 8 (R/W) and 9 (L/W)	
Resistance: 0.8 - 1.85 kΩ	
Is resistance 0.8 - 1.85 kΩ?	
Yes	▶ GO TO 5.
No	▶ GO TO 4.

SBR909E

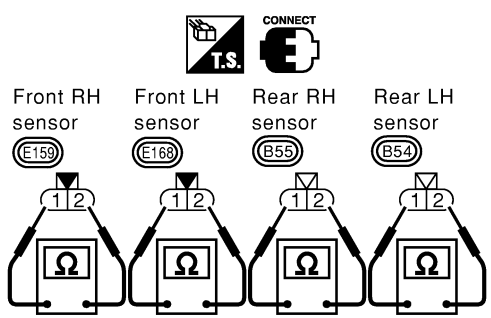
4	CHECK WHEEL SENSOR	
Check signal from sensors by "Simple oscilloscope" function of CONSULT-II (Scale: 0.2 V/Div, 20 ms/Div)		
		
SBR051F		
Does the wave appear on screen when wheel is rotated?		
Yes	▶	Repair harness and connectors between control unit connector and wheel sensor connector.
No	▶	Replace wheel sensor.

5	CHECK TIRE	
Check for inflation pressure, wear and size of each tire.		
Are tire pressure and size correct and is tire wear within specifications?		
Yes	▶	GO TO 6.
No	▶	Adjust tire pressure or replace tire(s).

GI
 MA
 EM
 LC
 EC
 FE
 CL
 MT
 AT
 AX
 SU
 BR
 ST
 RS
 BT
 HA
 SC
 EL
 IDX

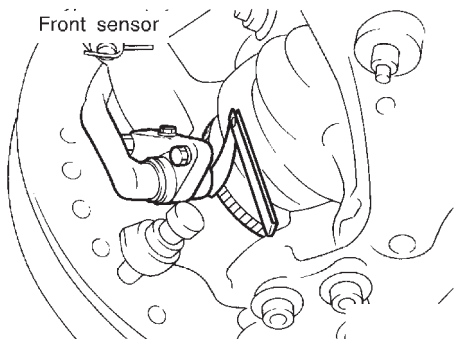
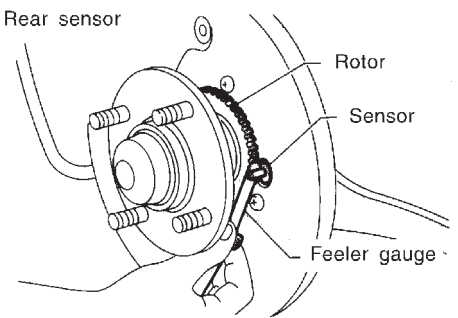
6	CHECK WHEEL BEARING		
Check wheel bearing axial end play. Check clearance between sensor and rotor. Clearance: Front 0.273 - 0.925 mm (0.0107 - 0.0364 in) Rear 0.387 - 0.992 mm (0.0152 - 0.0391 in)			
			
SBR605AA			
			
SBR069CA			
Is axial end play and clearance within specifications?			
Yes	▶	GO TO 7.	
No	▶	Clean sensor fixing portion, or replace sensor.	

7	CHECK SENSOR ROTOR		
Check sensor rotor for teeth damage.			
Is sensor rotor free from damage?			
Yes	▶	Check control unit pin terminals for damage or the connection of control unit harness connector. Reconnect control unit harness connector. Then retest.	
No	▶	Replace sensor rotor.	

8	CHECK POWER SUPPLY	
<p>1. Disconnect wheel sensor connector. 2. Check voltage between body side terminal of wheel sensor connectors and body ground.</p> <div style="text-align: center;"> <p style="font-size: small;">FR-RH FR-LH RR-RH RR-LH</p> <p style="font-size: x-small;">1 1 1 1</p> </div> <p style="text-align: right; font-size: x-small;">SBR984E</p>		GI MA EM LC EC FE CL MT AT AX SU BR ST RS BT HA SC EL IDX
Is voltage more than 8V?		
Yes	▶	Replace wheel sensor.
No	▶	Replace ABS control unit.

ABS Actuator Solenoid Valve or Solenoid Valve Relay

DIAGNOSTIC PROCEDURE

=NFBR0171

NFBR0171S01

1	INSPECTION START
Solenoid valve relay inspection	
SBR952E	
▶	GO TO 2.

2	CHECK SOLENOID VALVE POWER SUPPLY CIRCUIT
Check 40A [E] fusible link (ABS ACTR) for ABS solenoid valve relay. For fusible link layout, refer to POWER SUPPLY ROUTING in EL section.	
Is fusible link OK?	
Yes	▶ GO TO 3.
No	▶ GO TO 7.

3	CHECK FUSE
Check 10A fuse No. 31. For fuse layout, refer to "POWER SUPPLY ROUTING" in EL section.	
Is fuse OK?	
Yes	▶ GO TO 4.
No	▶ GO TO 9.

TROUBLE DIAGNOSES FOR SELF-DIAGNOSTIC ITEMS

TCS

ABS Actuator Solenoid Valve or Solenoid Valve Relay (Cont'd)

4	CHECK CONNECTOR	
1. Disconnect connectors from control unit and ABS actuator. Check terminals for damage or loose connection. Then reconnect connectors. 2. Carry out self-diagnosis again.		
Does warning lamp activate again?		
Yes	▶	GO TO 5.
No	▶	INSPECTION END

GI
MA
EM

5	CHECK GROUND CIRCUIT	
Refer to ABS ACTUATOR AND ELECTRIC UNIT in Ground Circuit Check, BR-106.		
Is ground circuit OK?		
Yes	▶	GO TO 6.
No	▶	Repair harness and connectors.

LC
EC
FE

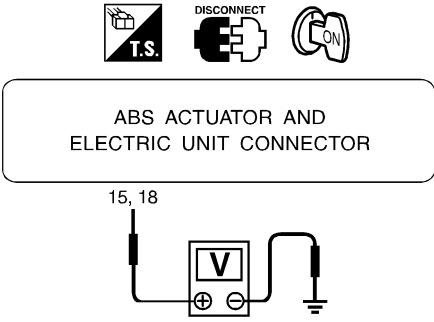
6	CHECK SOLENOID VALVE POWER SUPPLY CIRCUIT	
1. Disconnect ABS actuator and electric unit connector. 2. Check voltage between ABS actuator and electric unit harness connector E171 terminals 15 (GY) and 18 (L/B) and ground.		
		
SBR040F		
Does battery voltage exist when ignition switch is turned ON?		
Yes	▶	Replace ABS actuator and electric unit.
No	▶	Check the following. <ul style="list-style-type: none"> ● Harness connector E171 ● Harness for open or short between ABS actuator and electric unit and fusible link or fuse If NG, repair harness or connectors.

CL
MT
AT
AX
SU
BR



7	REPLACE FUSIBLE LINK	
Replace fusible link.		
Does the fusible link blow out when ignition switch is turned "ON"?		
Yes	▶	GO TO 8.
No	▶	INSPECTION END

HA
SC
EL
IDX

TROUBLE DIAGNOSES FOR SELF-DIAGNOSTIC ITEMS

TCS

ABS Actuator Solenoid Valve or Solenoid Valve Relay (Cont'd)

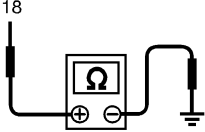
8	CHECK RELAY UNIT POWER SUPPLY CIRCUIT FOR SHORT	
<p>1. Disconnect battery cable and ABS actuator and electric unit connector. 2. Check continuity between ABS actuator and electric unit harness connector E171 terminal 18 (L/B) and ground.</p> <div style="text-align: center;">   </div> <div style="text-align: center; margin: 10px 0;"> <div style="border: 1px solid black; border-radius: 10px; padding: 5px; display: inline-block;"> ABS ACTUATOR AND ELECTRIC UNIT CONNECTOR </div> </div> <div style="text-align: center;">  </div> <p style="text-align: right; margin-right: 20px;">SBR041F</p> <p style="text-align: center;">Does continuity exist?</p>		
Yes	▶	<p>Check the following.</p> <ul style="list-style-type: none"> ● Harness connector E171 ● Harness for open or short between ABS actuator and electric unit and fusible link <p>If NG, repair harness or connectors.</p>
No	▶	Replace ABS actuator and electric unit.

9	REPLACE FUSE	
<p>Replace fuse.</p> <p style="text-align: center;">Does the fuse blow out when ignition switch is turned "ON"?</p>		
Yes	▶	<p>Check the following.</p> <ul style="list-style-type: none"> ● Harness connector E171 ● Harness for open or short between ABS actuator and electric unit and fuse <p>If NG, repair harness or connectors.</p>
No	▶	INSPECTION END

Motor Relay or Motor
DIAGNOSTIC PROCEDURE

=NFBR0172

NFBR0172S01

1	INSPECTION START
<p>ABS motor relay inspection</p> <p style="text-align: right;">SBR953E</p>	
▶	GO TO 2.

2	CHECK MOTOR POWER SUPPLY CIRCUIT
<p>Check 40A [D] fusible link (ABS MTR) for ABS motor relay. For fusible link layout, refer to POWER SUPPLY ROUTING in EL section.</p> <p style="text-align: center;">Is fusible link OK?</p>	
Yes	▶ GO TO 3.
No	▶ GO TO 6.

3	CHECK CONNECTOR
<p>1. Disconnect ABS/TCS CONTROL UNIT connector. Check terminals for damage or loose connection. Then reconnect connectors.</p> <p>2. Carry out self-diagnosis again.</p> <p style="text-align: center;">Does warning lamp activate again?</p>	
Yes	▶ GO TO 4.
No	▶ INSPECTION END

GI
MA
EM
LC
EC
FE
CL
MT
AT
AX
SU
BR
ST
RS
BT
HA
SC
EL
IDX

Motor Relay or Motor (Cont'd)

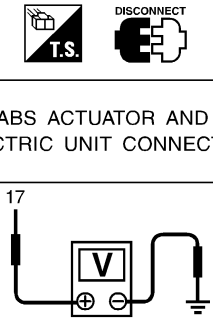
4	CHECK MOTOR RELAY POWER SUPPLY CIRCUIT	
<p>1. Disconnect ABS actuator and electric unit connector. 2. Check voltage between ABS actuator and electric unit harness connector E171 terminal 17 (Y) and ground.</p> <div style="text-align: center;">  <p style="margin: 0;">ABS ACTUATOR AND ELECTRIC UNIT CONNECTOR</p> <p style="margin: 0;">17</p> <p style="margin: 0;">V</p> <p style="margin: 0;">+</p> <p style="margin: 0;">-</p> <p style="margin: 0;">GND</p> </div> <p style="text-align: right; margin-right: 20px;">SBR898EB</p> <p style="text-align: center;">Does battery voltage exist?</p>		
Yes	▶	GO TO 5.
No	▶	<p>Check the following.</p> <ul style="list-style-type: none"> ● Harness connector E171 ● Harness for open or short between ABS actuator and electric unit and fusible link <p>If NG, repair harness or connectors.</p>

5	CHECK ABS ACTUATOR AND ELECTRIC UNIT GROUND CIRCUIT	
<p>Refer to ABS ACTUATOR AND ELECTRIC UNIT GROUND in Ground Circuit Check, BR-106.</p> <p style="text-align: center;">Is ground circuit OK?</p>		
Yes	▶	Replace ABS actuator and electric unit.
No	▶	<p>Check the following.</p> <ul style="list-style-type: none"> ● Harness connector E171 ● Harness for open or short between ABS actuator and electric unit and ground <p>If NG, repair harness or connectors.</p>

6	REPLACE FUSIBLE LINK	
<p>Replace fusible link.</p> <p style="text-align: center;">Does the fusible link blow out when ignition switch is turned "ON"?</p>		
Yes	▶	GO TO 7.
No	▶	INSPECTION END

7	CHECK ABS ACTUATOR MOTOR POWER SUPPLY CIRCUIT FOR SHORT	
<p>1. Disconnect battery cable and ABS actuator and electric unit connector. 2. Check continuity between ABS actuator and electric unit harness connector E171 terminal 17 (Y) and ground.</p> <div style="text-align: center;"> <p style="text-align: center;">Does continuity exist?</p> </div> <p style="text-align: right;">SBR042F</p>		
Yes	▶	Check ABS actuator and electric unit pin terminals for damage or the connection of ABS actuator and electric unit harness connector. Reconnect ABS actuator and electric unit harness connector. Then retest.
No	▶	<p>Check the following.</p> <ul style="list-style-type: none"> ● Harness connector E171 ● Harness for open or short between ABS actuator and electric unit and fusible link <p>If NG, repair harness or connectors.</p>

GI
 MA
 EM
 LC
 EC
 FE
 CL
 MT
 AT
 AX
 SU

BR

Low Voltage DIAGNOSTIC PROCEDURE

NFBR0173

NFBR0173S01

1	INSPECTION START	
<p>ABS actuator and electric unit power supply and ground circuit inspection</p> <div style="text-align: center;"> </div> <p style="text-align: right;">SBR914E</p>		
▶		GO TO 2.

ST
 RS
 BT
 HA
 SC
 EL
 IDX

Low Voltage (Cont'd)

2	CHECK CONNECTOR	
1. Disconnect ABS actuator and electric unit connector. Check terminals for damage or loose connections. Then reconnect connector. 2. Carry out self-diagnosis again.		
Does warning lamp activate again?		
Yes	▶	GO TO 3.
No	▶	INSPECTION END

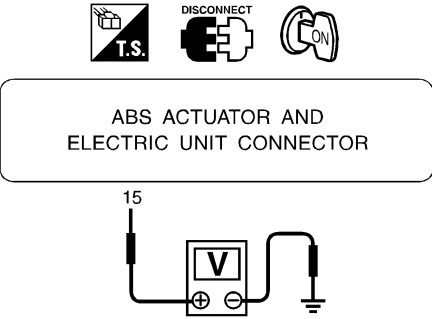
3	CHECK ABS ACTUATOR AND ELECTRIC UNIT POWER SUPPLY CIRCUIT	
1. Disconnect ABS actuator and electric unit connector. 2. Check voltage between ABS actuator and electric unit harness connector E171 terminal 15 (GY) and ground.		
		
Does battery voltage exist when ignition switch is turned ON?		
Yes	▶	GO TO 4.
No	▶	GO TO 5.

SBR915EB

4	CHECK ABS ACTUATOR AND ELECTRIC UNIT GROUND	
Refer to ABS ACTUATOR AND ELECTRIC UNIT GROUND in Ground Circuit Check, BR-106.		
Is ground circuit OK?		
OK	▶	Check ABS actuator and electric unit pin terminals for damage or the connection of ABS actuator and electric unit harness connector. Reconnect ABS actuator and electric unit harness connector. Then retest.
NG	▶	Check the following. <ul style="list-style-type: none"> ● Harness connector E171 ● Harness for open or short between ABS actuator and electric unit and ground If NG, repair harness or connectors.

5	CHECK FUSE	
Check 10A fuse 31 (Engine control) for control unit. Refer to POWER SUPPLY ROUTING in EL section.		
Is fuse OK?		
Yes	▶	GO TO 6.
No	▶	Replace fuse.

6	CHECK ABS ACTUATOR AND ELECTRIC UNIT POWER SUPPLY CIRCUIT	
Check continuity between battery and ABS actuator and electric unit connector terminal 15.		
Does continuity exist?		
Yes	▶	Check battery. Refer to BATTERY in EL section.
No	▶	Check the following. <ul style="list-style-type: none"> ● Harness connector E171 ● Harness for open or short between ABS actuator and electric unit and fuse If NG, repair harness or connectors.

GI
MA
EM
LC

Control Unit DIAGNOSTIC PROCEDURE

NFBR0174
NFBR0174S01

1	INSPECTION START	
ABS actuator and electric unit power supply and ground circuit inspection		
<small>SBR916E</small>		
▶		GO TO 2.

FE
CL
MT
AT
AX

2	CHECK CONNECTOR	
1. Disconnect ABS actuator and electric unit connector. Check terminals for damage or loose connections. Then reconnect connectors. 2. Carry out self-diagnosis again.		
Does warning lamp activate again?		
Yes	▶	GO TO 3.
No	▶	INSPECTION END

SU
BR
ST
RS

3	CHECK ABS ACTUATOR AND ELECTRIC UNIT POWER SUPPLY CIRCUIT	
Check voltage. Refer to "3. CHECK ABS ACTUATOR AND ELECTRIC UNIT POWER SUPPLY CIRCUIT" in "Low Voltage", BR-119.		
Does battery voltage exist when ignition switch is turned ON?		
Yes	▶	GO TO 4.
No	▶	Repair.

BT
HA
SC

4	CHECK WARNING LAMP INDICATION	
Check "SELF DIAGNOSIS RESULTS", if "CONTROLLER FAILRE" is indicated on the screen.		
Yes	▶	Replace ABS actuator and electric unit.
No	▶	Inspect the system according to the code No.

EL
IDX

TROUBLE DIAGNOSES FOR SELF-DIAGNOSTIC ITEMS

TCS

CAN Communication Line

CAN Communication Line DIAGNOSTIC PROCEDURE

NFBR0175

NFBR0175S01

1	SELF-DIAGNOSIS RESULT CHECK											
Check the self-diagnosis results.												
<table border="1" style="margin-left: auto; margin-right: auto;"> <thead> <tr> <th style="width: 50%;">Normal</th> <th style="width: 50%;">Abnormal (example)</th> </tr> </thead> <tbody> <tr> <td>CAN_COMM: OK</td> <td>CAN_COMM: OK</td> </tr> <tr> <td>CAN_CIRC_1: OK</td> <td>CAN_CIRC_1: UNKWN</td> </tr> <tr> <td>CAN_CIRC_2: OK</td> <td>CAN_CIRC_2: UNKWN</td> </tr> <tr> <td>CAN_CIRC_3: OK</td> <td>CAN_CIRC_5: UNKWN</td> </tr> </tbody> </table>			Normal	Abnormal (example)	CAN_COMM: OK	CAN_COMM: OK	CAN_CIRC_1: OK	CAN_CIRC_1: UNKWN	CAN_CIRC_2: OK	CAN_CIRC_2: UNKWN	CAN_CIRC_3: OK	CAN_CIRC_5: UNKWN
Normal	Abnormal (example)											
CAN_COMM: OK	CAN_COMM: OK											
CAN_CIRC_1: OK	CAN_CIRC_1: UNKWN											
CAN_CIRC_2: OK	CAN_CIRC_2: UNKWN											
CAN_CIRC_3: OK	CAN_CIRC_5: UNKWN											
MTBL1187												
Is the other item except above indicated in self-diagnosis results?												
Yes	▶	Repair or replace related parts.										
No	▶	GO TO 2.										

2	CAN COMMUNICATION SYSTEM CHECK			
Check "CAN diagnosis support monitor" of the data monitor items.				
<table border="1" style="margin-left: auto; margin-right: auto;"> <tbody> <tr> <td style="text-align: center;">Self-diagnosis results</td> </tr> <tr> <td style="text-align: center;">D000 CAN_COMM_CIRCUIT</td> </tr> </tbody> </table>			Self-diagnosis results	D000 CAN_COMM_CIRCUIT
Self-diagnosis results				
D000 CAN_COMM_CIRCUIT				
MTBL1188				
▶ After printing the monitor items, go to CAN SYSTEM. Refer to EL-437, "CHECK SHEET".				

Engine System DIAGNOSTIC PROCEDURE

NFBR0176

NFBR0176S01

1	SELF-DIAGNOSIS RESULT CHECK 1					
Check the self-diagnosis results.						
<table border="1" style="margin-left: auto; margin-right: auto;"> <tbody> <tr> <td style="text-align: center;">Self-diagnosis results</td> </tr> <tr> <td style="text-align: center;">ENGINE_SIGNAL_1</td> </tr> <tr> <td style="text-align: center;">ENGINE_SIGNAL_2</td> </tr> <tr> <td style="text-align: center;">ENGINE_SIGNAL_3</td> </tr> </tbody> </table>			Self-diagnosis results	ENGINE_SIGNAL_1	ENGINE_SIGNAL_2	ENGINE_SIGNAL_3
Self-diagnosis results						
ENGINE_SIGNAL_1						
ENGINE_SIGNAL_2						
ENGINE_SIGNAL_3						
MTBL1189						
Are any items other than above indicated in self-diagnosis results?						
Yes	▶	Repair or replace harness or connector.				
No	▶	GO TO 2.				

TROUBLE DIAGNOSES FOR SELF-DIAGNOSTIC ITEMS

TCS

Engine System (Cont'd)

2	SELF-DIAGNOSIS RESULT CHECK 2	
1. Perform the ECM self-diagnosis, and repair or replace harness or connector, then perform the ECM self-diagnosis again. 2. Perform the TCS/ABS control unit self-diagnosis again.		
Is inspection result OK?		
OK	▶	INSPECTION END
NG	▶	Repair or replace harness or connector. Perform the self-diagnosis again.

GI

MA

EM

LC

A/T System DIAGNOSTIC PROCEDURE

NFBR0208

NFBR0208S01

1	SELF-DIAGNOSIS RESULT CHECK 1			
Check the self-diagnosis results.				
<table style="margin: auto; border-collapse: collapse;"> <tr> <td style="border-top: 1px solid black; border-bottom: 1px solid black; padding: 2px 20px;">Self-diagnosis results</td> </tr> <tr> <td style="border-top: 1px solid black; border-bottom: 1px solid black; padding: 2px 20px;">A/T_SIGNAL</td> </tr> </table>			Self-diagnosis results	A/T_SIGNAL
Self-diagnosis results				
A/T_SIGNAL				
<small>MTBL1190</small>				
Are any items other than above indicated in self-diagnosis results?				
Yes	▶	Repair or replace related parts.		
No	▶	GO TO 2.		

EC

FE

CL

MT

AT

2	SELF-DIAGNOSIS RESULT CHECK 2	
1. Perform the TCM self-diagnosis, and replace harness or connector, then perform the TCM self-diagnosis again. 2. Perform the ABS/TCS control unit self-diagnosis again.		
Is inspection result OK?		
OK	▶	INSPECTION END
NG	▶	Repair or replace related parts.

AX

SU

BR

ST

RS

BT

HA

SC

EL

IDX

1. ABS Works Frequently

NFBR0188

1	CHECK WHEEL SENSOR	
1. Check wheel sensor connector for terminal damage or loose connections. 2. Perform wheel sensor mechanical check. Refer to "Wheel Sensor or Rotor", BR-110.		
Are wheel sensors functioning properly?		
Yes	▶	GO TO 2.
No	▶	Repair.

2	CHECK FRONT AXLE	
Check front and rear axles for excessive looseness. Refer to AX section, "Front Wheel Bearing", "ON-VEHICLE SERVICE" and "Rear Wheel Bearing", "ON-VEHICLE SERVICE".		
Is front axle installed properly?		
Yes	▶	Go to "3. CHECK WARNING LAMP INDICATION" in "2. Unexpected Pedal Action", BR-124.
No	▶	Repair.

2. Unexpected Pedal Action

NFBR0189

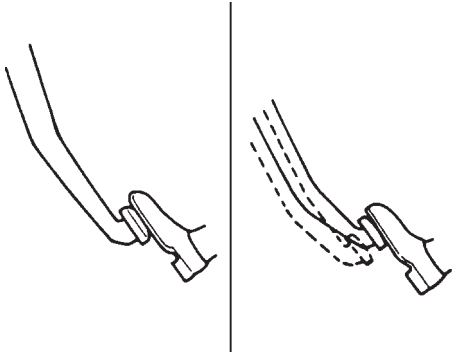
1	CHECK BRAKE PEDAL STROKE	
Check brake pedal stroke. Is stroke excessively large?		
		
SBR540A		
Yes	▶	Perform Preliminary Check. Refer to BR-103.
No	▶	GO TO 2.

2	CHECK CONNECTOR AND PERFORMANCE	
1. Disconnect ABS actuator and electric unit connector. 2. Check whether brake is effective.		
Yes or No?		
Yes	▶	GO TO 3.
No	▶	Perform Preliminary Check. Refer to BR-103.

TROUBLE DIAGNOSES FOR SYMPTOMS

TCS

2. Unexpected Pedal Action (Cont'd)

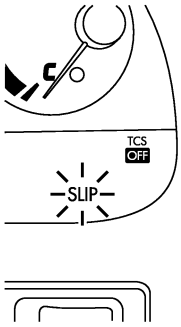
3	CHECK WARNING LAMP INDICATION	
Ensure warning lamp remains off while driving.		
		
SBR655E		
Is warning lamp turned off?		
Yes	▶	GO TO 4.
No	▶	Carry out self-diagnosis. Refer to BR-96.

4	CHECK WHEEL SENSOR	
1. Check wheel sensor connector for terminal damage or loose connection. 2. Perform wheel sensor mechanical check. Refer to "Wheel Sensor Rotor", BR-110.		
Is wheel sensor mechanism OK?		
Yes	▶	Check control unit pin terminals for damage or the connection of control unit harness connector. Reconnect control unit harness connector. Then retest.
No	▶	Repair.

3. Long Stopping Distance

NFBR0190

1	CHECK CONNECTOR AND PERFORMANCE	
1. Cancel ABS by removing 40A [E] fusible link (ABS ACTR) for ABS solenoid valve relay. 2. Check stopping distance.		
OK or NG		
OK	▶	Perform Preliminary Check and air bleeding.
NG	▶	Go to "3. CHECK WARNING LAMP INDICATION" in "2. Unexpected Pedal Action", BR-124.

NOTE:

Stopping distance may be longer than vehicles without ABS when road condition is slippery.

GI
MA
EM
LC
EC
FE
CL
MT
AT
AX
SU
BR
ST
RS
BT
HA
SC
EL
IDX

4. ABS Does Not Work

NFBR0191

1	CHECK WARNING LAMP INDICATION	
Does the ABS warning lamp activate?		
Yes	▶	Carry out self-diagnosis. Refer to BR-96.
No	▶	Go to "3. CHECK WARNING LAMP INDICATION" in "2. Unexpected Pedal Action", BR-124.

NOTE:

ABS does not work when vehicle speed is under 10 km/h (6 MPH).

5. Pedal Vibration and Noise

=NFBR0192

1	INSPECTION START	Pedal vibration and noise inspection <div style="text-align: center;">  </div>	GI MA EM LC EC SAT797A
▶		GO TO 2.	

2	CHECK SYMPTOM	1. Apply brake. 2. Start engine. <p style="text-align: center;">Does the symptom appear only when engine is started?</p>	CL MT AT
Yes	▶	Carry out self-diagnosis. Refer to BR-96.	
No	▶	GO TO 3.	

3	RECHECK SYMPTOM	Does the symptom appear when electrical equipment switches (such as headlamp) are operated?	AX SU BR
Yes	▶	Check control unit pin for damage or the connection of control unit harness connector. Then reconfirm the continuity.	
No	▶	Go to "3. CHECK WARNING LAMP INDICATION" in "2. Unexpected Pedal Action", BR-124.	

NOTE:

ABS may operate and cause vibration under any of the following conditions.

- Applying brake gradually when shifting or operating clutch.
- Low friction (slippery) road.
- High speed cornering.
- Driving over bumps and pot holes.
- Engine speed is over 5,000 rpm with vehicle stopped.

GI
MA
EM
LC
EC
FE
CL
MT
AT
AX
SU
BR
ST
RS
BT
HA
SC
EL
IDX

6. ABS Warning Lamp Does Not Come On When Ignition Switch Is Turned On

6. ABS Warning Lamp Does Not Come On When Ignition Switch Is Turned On

=NFBR0193

1	INSPECTION START
Warning lamp circuit inspection	
▶	GO TO 2.

2	CHECK FUSE
Check 10A fuse No. 30 for warning lamp. For fuse layout, refer to "POWER SUPPLY ROUTING" in EL section.	
Is fuse OK?	
Yes	▶ GO TO 3.
No	▶ Replace fuse.

3	CHECK ABS CONTROL UNIT POWER SUPPLY CIRCUIT
<ol style="list-style-type: none"> 1. Install 10A fuse. 2. Check voltage between control unit harness connector E171 terminal 21 (LY) and ground after turning ignition switch "ON". 	
Does battery voltage exist after turning ignition switch "ON"?	
Yes	▶ GO TO 4.
No	▶ Repair.

4	CHECK WARNING LAMP
Check warning lamp bulb.	
Is warning lamp bulb OK?	
Yes	▶ Repair harness and connectors between fuse and control unit connector terminal 30 (including combination meter).
No	▶ Replace bulb.

7. ABS Warning Lamp Stays On When Ignition Switch Is Turned On

=NFBR0194

1	INSPECTION START
ABS control unit inspection	
SBR919E	
▶	GO TO 2.

2	CHECK FUSE
Check 10A fuse No. 31 for control unit. For fuse layout, refer to "POWER SUPPLY ROUTING" in EL section.	
Is fuse OK?	
Yes	▶ GO TO 3.
No	▶ GO TO 5.

3	CHECK ABS/TCS CONTROL UNIT POWER SUPPLY CIRCUIT
1. Disconnect connector from control unit. 2. Check voltage between control unit harness connector E171 terminal 15 (GY) and ground after turning ignition switch "ON".	
Does battery voltage exist?	
Yes	▶ GO TO 4.
No	▶ Check the following. <ul style="list-style-type: none"> ● Harness connector E171 ● Harness for open or short between control unit and fuse If NG, repair harness or connectors.
SBR920EA	

GI
 MA
 EM
 LC
 EC
 FE
 CL
 MT
 AT
 AX
 SU
 BR
 ST
 RS
 BT
 HA
 SC
 EL
 IDX

7. ABS Warning Lamp Stays On When Ignition Switch Is Turned On (Cont'd)

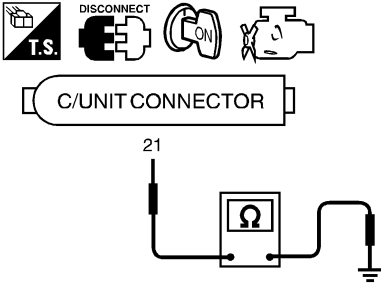
4	CHECK WARNING LAMP GROUND CIRCUIT	
<p>1. Turn ignition switch "OFF". 2. Disconnect connectors from control unit. 3. Check continuity between control unit harness connector E171 terminal 21 (LY) and body ground.</p>		
		
SBR921EB		
Does continuity exist?		
Yes	▶	<p>Check the following.</p> <ul style="list-style-type: none"> ● Harness connector E171 ● Harness for open or short between control unit and fuse <p>If NG, repair harness or connectors.</p>
No	▶	<p>Check control unit pin terminals for damage or the connection of control unit harness connector. Reconnect control unit harness connector. Then retest.</p>

5	REPLACE FUSE	
<p>Replace 10A fuse No. 31.</p>		
Does the fuse blow out when ignition switch is turned "ON"?		
Yes	▶	GO TO 6.
No	▶	INSPECTION END

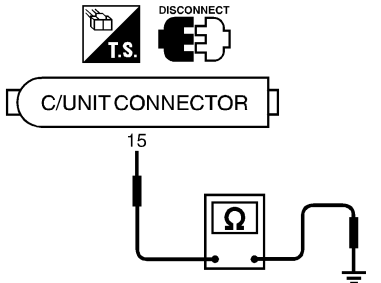
6	CHECK ABS/TCS CONTROL UNIT POWER SUPPLY CIRCUIT FOR SHORT	
<p>1. Disconnect control unit connector. 2. Check continuity between control unit harness connector E171 terminal 15 (GY) and body ground.</p>		
		
SBR922EB		
Does continuity exist?		
Yes	▶	<p>Check the following.</p> <ul style="list-style-type: none"> ● Harness connector E171 ● Harness for open or short between control unit and fuse <p>If NG, repair harness or connectors.</p>
No	▶	<p>Check control unit pin terminals for damage or the connection of control unit harness connector. Reconnect control unit harness connector. Then retest.</p>

8. SLIP Indicator Lamp Does Not Come On When Ignition Switch Is Turned On

=NFBR0195

1	INSPECTION START
Indicator lamp circuit inspection	
SBR923E	
▶	GO TO 2.

2	CHECK FUSE
Check 10A fuse No. 30 for control unit. For fuse layout, refer to "POWER SUPPLY ROUTING" in EL section.	
Is fuse OK?	
Yes	▶ GO TO 3.
No	▶ Replace fuse.

3	CHECK CONTROL UNIT POWER SUPPLY CIRCUIT
<ol style="list-style-type: none"> 1. Install 10A fuse. 2. Disconnect connector from control unit. 3. Check voltage between control unit harness connector E171 terminal 28 (R/Y) and ground after turning ignition switch "ON". 	
Does battery voltage exist?	
Yes	▶ GO TO 5.
No	▶ GO TO 4.

4	CHECK INDICATOR LAMP
Check indicator lamp bulb.	
Is indicator lamp bulb OK?	
Yes	▶ Repair harness and connectors between fuse and control unit harness connector M32 (including combination meter harness connector M34).
No	▶ Replace bulb.

GI
MA
EM
LC
EC
FE
CL
MT
AT
AX
SU
BR
ST
RS
BT
HA
SC
EL
IDX

8. SLIP Indicator Lamp Does Not Come On When Ignition Switch Is Turned On (Cont'd)

5	CHECK CIRCUIT	<ol style="list-style-type: none"> 1. Disconnect control unit connector. 2. Check continuity between control unit harness connector E171 terminal 12 (W/B) and data link harness connector M28 terminal 9 (P/B). <div style="text-align: center; margin: 10px 0;"> <p style="font-size: small;">ABS/TCS control unit connector Data link connector</p> <p style="font-size: x-small;">C/UNITCONNECTOR 9</p> <p style="font-size: x-small;">12</p> <p style="font-size: x-small;">Ω</p> </div> <p style="text-align: right; font-size: x-small;">SBR925EB</p>
Does continuity exist?		
Yes	▶	GO TO 6.
No	▶	Check the following. <ul style="list-style-type: none"> ● Harness connectors E171, M28 ● Harness for open or short between control unit and data link connector

6	CHECK CONNECTOR	<ol style="list-style-type: none"> 1. Disconnect connector from control unit. Check terminals for damage or loose connection. Then reconnect connector. 2. Carry out self-diagnosis again. <p style="text-align: center; font-weight: bold; font-size: small;">Does warning lamp activate again?</p>
Yes	▶	Check items the self-diagnosis detected as faulty.
No	▶	INSPECTION END

9. TCS OFF Indicator Lamp Does Not Come On When Ignition Switch Is Turned On

NFBR0196

1	INSPECTION START	<p>Indicator lamp circuit inspection</p> <div style="text-align: center; margin: 10px 0;"> <p style="font-size: x-small;">30 ABS warning lamp</p> <p style="font-size: x-small;">IGN 10A</p> <p style="font-size: x-small;">TCS OFF indicator lamp</p> <p style="font-size: x-small;">SLIP indicator lamp</p> <p style="font-size: x-small;">28 26 21</p> <p style="font-size: x-small;">ABS/TCS control unit</p> <p style="font-size: x-small;">To ABS actuator</p> </div> <p style="text-align: right; font-size: x-small;">SBR926E</p>
▶		GO TO 2.

TROUBLE DIAGNOSES FOR SYMPTOMS

TCS

9. TCS OFF Indicator Lamp Does Not Come On When Ignition Switch Is Turned On (Cont'd)

2	CHECK FUSE
Check 10A fuse No. 30 for control unit. For fuse layout, refer to "POWER SUPPLY ROUTING" in EL section.	
Is fuse OK?	
Yes	▶ GO TO 3.
No	▶ Replace fuse.

3	CHECK CONTROL UNIT POWER SUPPLY CIRCUIT
<p>1. Install 10A fuse. 2. Disconnect connector from control unit. 3. Check voltage between control unit harness connector E171 terminal 26 (R) and ground after turning ignition switch "ON".</p>	
<p style="text-align: center;">ABS/TCS control unit</p> <p style="text-align: center;">C/UNIT CONNECTOR</p> <p style="text-align: center;">26</p> <p style="text-align: center;">V</p> <p style="text-align: center;">+</p> <p style="text-align: center;">-</p> <p style="text-align: center;">-</p>	
Does battery voltage exist?	
Yes	▶ GO TO 5.
No	▶ GO TO 4.

SBR927EB

4	CHECK INDICATOR LAMP
Check indicator lamp bulb.	
Is indicator lamp bulb OK?	
Yes	▶ Repair harness and connectors between control unit harness connector terminal 26 (R) and fuse box (including combination meter harness connector M32).
No	▶ Replace bulb.

5	CHECK CONNECTOR
<p>1. Disconnect connector from control unit. Check terminals for damage or loose connection. Then reconnect connector. 2. Carry out self-diagnosis again.</p>	
Does warning lamp activate again?	
Yes	▶ Check items the self-diagnosis detected as faulty.
No	▶ INSPECTION END

GI
MA
EM
LC
EC
FE
CL
MT
AT
AX
SU
BR
ST
RS
BT
HA
SC
EL
IDX

10. TCS OFF Switch Is Inoperative

=NFBR0197

1	INSPECTION START	<p>Inspect TCS OFF switch.</p> <div style="text-align: center;"> </div>
▶		GO TO 2.

SBR928E

2	CHECK TCS OFF SWITCH	<p>1. Remove TCS OFF switch and disconnect TCS OFF switch connector. 2. Check continuity between terminal 2 and 3 for TCS OFF switch connector M45.</p> <div style="text-align: center;"> </div> <p style="color: blue; margin-top: 10px;"> When TCS OFF switch is pressed: Continuity should exist. When TCS OFF switch is released: Continuity should not exist. </p>
▶		GO TO 3.
▶		Replace TCS OFF switch.

SBR544EA

TROUBLE DIAGNOSES FOR SYMPTOMS

TCS

10. TCS OFF Switch Is Inoperative (Cont'd)

3	CHECK TCS OFF SWITCH POWER SUPPLY CIRCUIT	
<ul style="list-style-type: none"> ● Disconnect connector from control unit. ● Check continuity between control unit harness connector E171 terminal 31 (SB) and TCS OFF switch harness connector M45 terminal 2 (SB). 		
SBR929EB		
Does continuity exist?		
Yes	▶	GO TO 4.
No	▶	Check the following. <ul style="list-style-type: none"> ● Harness connectors E171, M45 ● Harness for open or short between TCS OFF switch terminal (body side) and control unit If NG, repair harness or connectors.

GI
 MA
 EM
 LC
 EC
 FE
 CL
 MT
 AT
 AX
 SU
 BR
 ST
 RS
 BT
 HA
 SC
 EL
 IDX

4	CHECK TCS OFF SWITCH POWER SUPPLY	
Check continuity between TCS OFF switch harness connector M45 terminal 2 (SB) and ground.		
SBR546EA		
Does continuity exist?		
Yes	▶	GO TO 5.
No	▶	Repair harness and connectors.

TROUBLE DIAGNOSES FOR SYMPTOMS

TCS

10. TCS OFF Switch Is Inoperative (Cont'd)

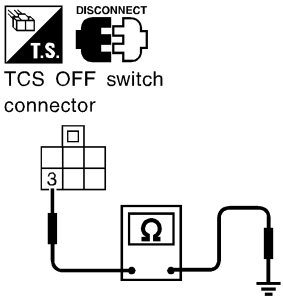
5	CHECK TCS OFF SWITCH GROUND CIRCUIT	
<p>Check continuity between TCS OFF switch harness connector M45 terminal 3 (B) and ground.</p> <div style="text-align: center; margin: 10px 0;">  <p style="font-size: small; margin: 0;">DISCONNECT TCS OFF switch connector</p> </div> <p style="text-align: right; margin-top: 10px;">SBR547EA</p>		
Does continuity exist?		
Yes	▶	Connect TCS OFF switch connector and check switch operation.
No	▶	Repair harness and connectors.

11. Poor Acceleration

=NFB0198

1	INSPECTION START		
		Engine acceleration is poor while TCS is operating. Vehicle instability is caused by unstable engine rpm operation. (Engine is shaking.)	GI
		▶	MA
		GO TO 2.	EM

2	CHECK PERFORMANCE		
		1. Cancel TCS operation using TCS OFF switch. (TCS OFF indicator lamp lights.) 2. Drive vehicle or accelerate engine.	EM
		Is engine acceleration poor or does automatic transaxle shift when TCS is not operating?	LC
		Yes ▶	EC
		Go to "TROUBLE DIAGNOSES" in BR section.	FE
		No ▶	CL
		GO TO 3.	MT

3	CHECK SELF-DIAGNOSIS		
		Perform self-diagnostic procedures for TCM.	FE
		Does any of the following self-diagnostic items appear on the display?	CL
		Yes ▶	AT
		Go to "TROUBLE DIAGNOSES" in AT section.	AX
		No ▶	SU
		GO TO 4.	BR

4	CHECK SELF-DIAGNOSIS		
		Perform self-diagnostic procedures for ABS/TCS.	AT
		Does any of the following self-diagnostic items appear on the display?	AX
		Yes ▶	SU
		Go to "TROUBLE DIAGNOSES" in BR section.	BR
		No ▶	ST
		GO TO 5.	RS

5	CHECK SELF-DIAGNOSIS		
		Perform self-diagnostic procedures for ECM.	BR
		Does any of the following self-diagnostic items appear on the display?	ST
		Yes ▶	RS
		Go to "TROUBLE DIAGNOSES" in EC section.	BT
		No ▶	HA
		INSPECTION END	SC

GI
 MA
 EM
 LC
 EC
 FE
 CL
 MT
 AT
 AX
 SU
 BR
 ST
 RS
 BT
 HA
 SC
 EL
 IDX

CAUTION:

Be careful not to damage sensor edge and sensor rotor teeth. When removing the front or rear wheel hub assembly, first remove the ABS wheel sensor from the assembly. Failure to do so may result in damage to the sensor wires making the sensor inoperative.

Wheel Sensors

NFBR0199S01

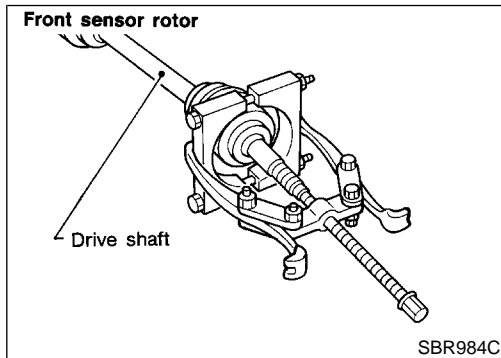
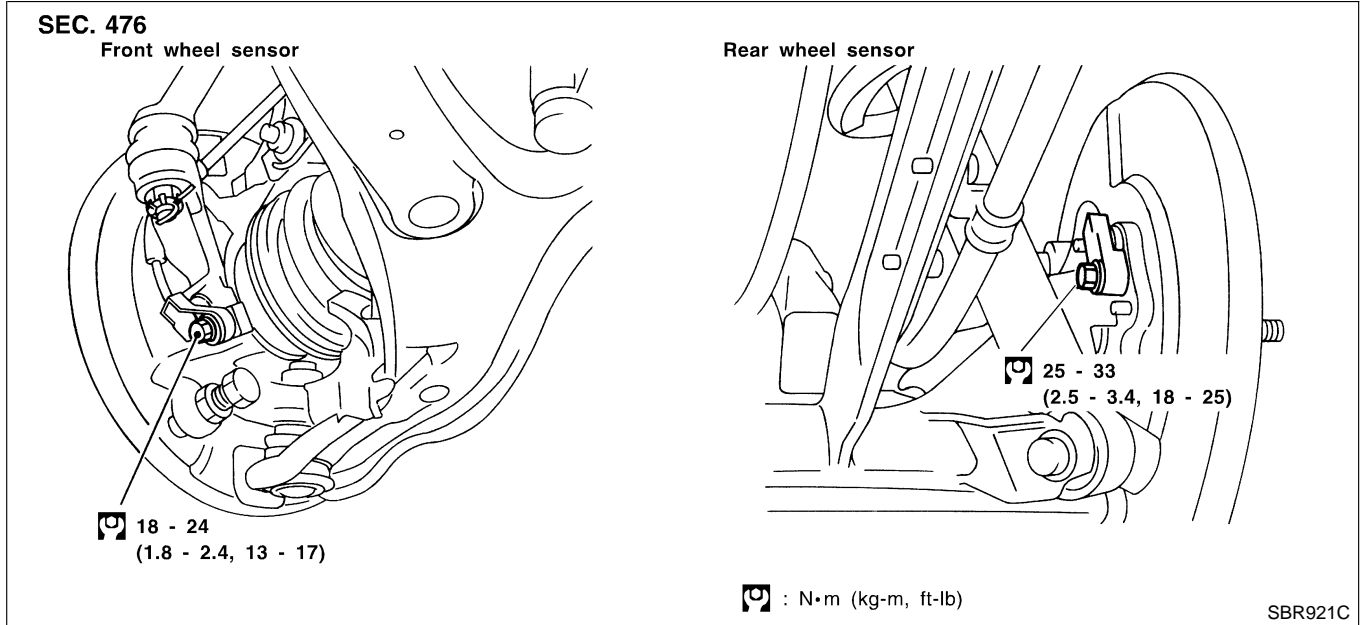

Sensor Rotor REMOVAL

NFBR0199S02

NFBR0199S0201

1. Remove the drive shaft and rear wheel hub. Refer to "Drive Shaft" and "Wheel Hub" in AX section.
2. Remove the sensor rotor using suitable puller, drift and bearing replacer.

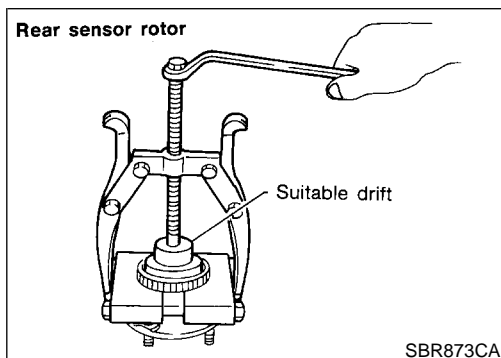

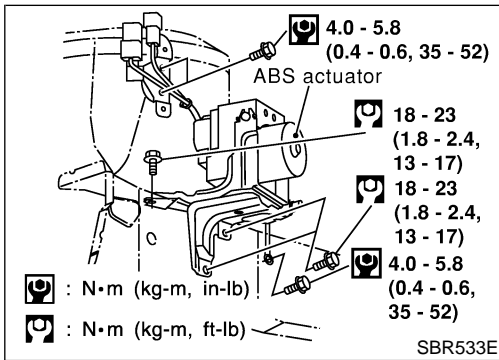
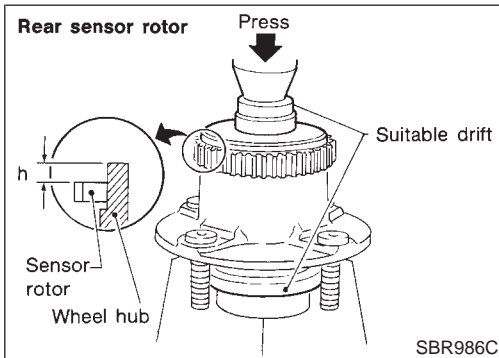
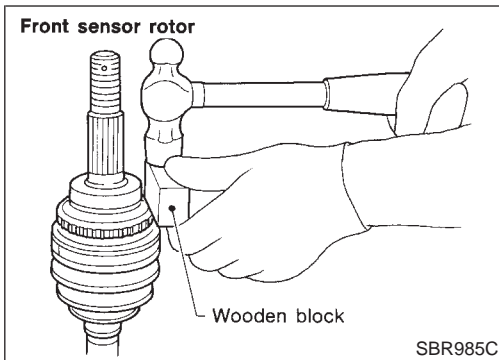

INSTALLATION

Install the sensor rotor. For front sensor rotor, use hammer and wooden block. For rear sensor rotor, use suitable drift and press. NFBR0199S0202

- Always replace sensor rotor with new one.

- Pay attention to the dimension of rear sensor rotor as show in figure.

h: 12.5 - 13.5 mm (0.492 - 0.531 in)

ABS Actuator and Electric Unit

REMOVAL

- Disconnect battery cable.
- Drain brake fluid. Refer to "Changing Brake Fluid" (BR-8).
- Remove air cleaner and duct.
- Apply different colored paint to each pipe connector and actuator to prevent incorrect connection.
- Disconnect harness connectors and brake pipes, then remove ABS actuator and electric unit and remove fixing nuts and actuator ground cable.

INSTALLATION

CAUTION:

- After installation, refill brake fluid. Then bleed air. Refer to "Bleeding Brake System" (BR-9).

- Temporarily install actuator on the bracket.
- Tighten actuator ground cable.
- Connect brake pipes temporarily.
- Tighten fixing nuts.
- Tighten brake pipes.
- Connect harness connectors and battery cable.
- Install air cleaner and duct.

GI
MA
EM
LC
EC
FE
CL
MT
AT
AX
SU
BR
ST
RS
BT
HA
SC
EL
IDX

SERVICE DATA AND SPECIFICATIONS (SDS)

General Specifications

General Specifications

NFBR0200
Unit: mm (in)

Front brake	Brake model		CLZ25VD disc brake
	Cylinder bore diameter		57.2 (2.252)
	Pad Length × width × thickness		125.6 × 46 × 9.5 (4.94 × 1.81 × 0.374)
	Rotor outer diameter × thickness		296 × 24 (11.65 × 0.94)
Rear brake	Brake model		CL9HE disc brake
	Cylinder bore diameter		33.96 (1.3370)
	Pad Length × width × thickness		89.1 × 39.5 × 10 (3.508 × 1.555 × 0.39)
	Rotor outer diameter × thickness		278 × 9 (10.94 × 0.35)
Master cylinder	Cylinder bore diameter		23.81 (15/16)
Brake booster	Booster model		M215T
	Diaphragm diameter	Primary	230 (9.06)
		Secondary	205 (8.07)
Recommended brake fluid			DOT 3

Disc Brake

NFBR0201
Unit: mm (in)

Brake model		CLZ25VD	CL9HE
Pad wear limit	Minimum thickness	2.0 (0.079)	1.5 (0.059)
	Maximum runout	0.07 (0.0028)	0.07 (0.0028)
Rotor repair limit	Minimum thickness	22.0 (0.866)	8.0 (0.315)

Brake Pedal

NFBR0202
Unit: mm (in)

Pedal play	3 - 11 (0.12 - 0.43)
Free height "H"*	167 - 174 (6.57 - 6.85)
Clearance "C" between pedal stopper and threaded end of stop lamp switch or ASCD switch	0.74 - 1.96 (0.0291 - 0.0772)

*: Measured from surface of dash reinforcement panel to surface of pedal pad

Parking Brake

NFBR0203

Control type	Center lever	Foot lever
Number of notches [under force of 196 N (20 kg, 44 lb)]	10 - 11	4 - 5
Number of notches when warning lamp switch comes on	1	

Brake Booster

NFBR0205
Unit: mm (in)

Output rod length	10.275 - 10.525 (0.4045 - 0.4144)
Clevis length (Dimension "A")	130 (5.12)

SERVICE DATA AND SPECIFICATIONS (SDS)

ABS Wheel Sensor

ABS Wheel Sensor

NFBR0206

Clearance	Front		0.273 - 0.925 mm (0.0107 - 0.0364 in)	GI
	Rear		0.385 - 0.973 mm (0.0252 - 0.0383 in)	
Resistance	Front	M/T	0.8 - 1.85Ω	MA
		A/T	—	
	Rear	M/T	0.8 - 1.85Ω	EM
		A/T	—	
Dimension of rear sensor rotor			12.5 - 13.5 mm (0.4921 - 0.5315 in)	LC

EC

FE

CL

MT

AT

AX

SU

BR

ST

RS

BT

HA

SC

EL

IDX

NOTES