

# CLUTCH

# SECTION CL

GI  
MA  
EM  
LC  
EC  
FE  
**CL**  
MT  
AT  
AX  
SU  
BR  
ST  
RS  
BT  
HA  
SC  
EL  
IDX

## CONTENTS

<p><b>PRECAUTIONS</b> .....2</p> <p style="padding-left: 20px;">Precautions .....2</p> <p><b>PREPARATION</b> .....3</p> <p style="padding-left: 20px;">Special Service Tools .....3</p> <p style="padding-left: 20px;">Commercial Service Tools .....3</p> <p><b>NOISE, VIBRATION AND HARSHNESS (NVH)</b></p> <p><b>TROUBLESHOOTING</b> .....4</p> <p style="padding-left: 20px;">NVH Troubleshooting Chart .....4</p> <p style="padding-left: 40px;">CLUTCH .....4</p> <p><b>CLUTCH SYSTEM</b> .....5</p> <p style="padding-left: 20px;">Components .....5</p> <p style="padding-left: 20px;">Inspection and Adjustment .....6</p> <p style="padding-left: 40px;">ADJUSTING CLUTCH PEDAL .....6</p> <p style="padding-left: 40px;">AIR BLEEDING PROCEDURE .....7</p> <p><b>CLUTCH MASTER CYLINDER</b> .....8</p> <p style="padding-left: 20px;">Components .....8</p> <p style="padding-left: 20px;">Removal .....8</p> <p style="padding-left: 20px;">Installation .....8</p> <p style="padding-left: 20px;">Disassembly .....9</p> <p style="padding-left: 20px;">Inspection .....9</p> <p style="padding-left: 20px;">Assembly .....9</p> <p><b>OPERATING CYLINDER</b> .....10</p> <p style="padding-left: 20px;">Components .....10</p> <p style="padding-left: 20px;">Removal .....10</p> <p style="padding-left: 20px;">Disassembly .....10</p> <p style="padding-left: 20px;">Inspection .....10</p>	<p style="padding-left: 20px;">Assembly .....11</p> <p style="padding-left: 20px;">Installation .....11</p> <p><b>PIPING</b> .....12</p> <p style="padding-left: 20px;">Removal .....12</p> <p style="padding-left: 20px;">Installation .....12</p> <p><b>CLUTCH RELEASE MECHANISM</b> .....13</p> <p style="padding-left: 20px;">Components .....13</p> <p style="padding-left: 20px;">Removal .....13</p> <p style="padding-left: 20px;">Inspection .....13</p> <p style="padding-left: 20px;">Installation .....13</p> <p><b>CLUTCH DISC, CLUTCH COVER AND FLYWHEEL</b> .....15</p> <p style="padding-left: 20px;">Components .....15</p> <p style="padding-left: 20px;">Inspection and Adjustment .....15</p> <p style="padding-left: 40px;">CLUTCH DISC .....15</p> <p style="padding-left: 40px;">CLUTCH COVER .....15</p> <p style="padding-left: 40px;">FLYWHEEL .....16</p> <p style="padding-left: 20px;">Installation .....16</p> <p><b>SERVICE DATA AND SPECIFICATIONS (SDS)</b> .....17</p> <p style="padding-left: 20px;">Clutch Control System .....17</p> <p style="padding-left: 20px;">Clutch Master Cylinder .....17</p> <p style="padding-left: 20px;">Clutch Operating Cylinder .....17</p> <p style="padding-left: 20px;">Clutch Disc .....17</p> <p style="padding-left: 20px;">Clutch Cover .....17</p> <p style="padding-left: 20px;">Clutch Pedal .....17</p>
--	---

# PRECAUTIONS

## Precautions

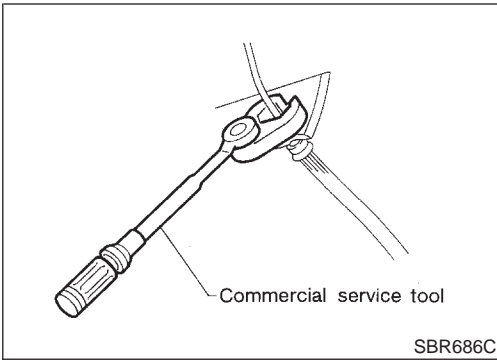

NFCL0001

### Precautions

- Recommended fluid is brake fluid “DOT 3”.
- Never reuse drained brake fluid.
- Be careful not to splash brake fluid on painted areas.
- When removing and installing clutch piping, use Tool.
- Use new brake fluid to clean or wash all parts of master cylinder and operating cylinder.
- Never use mineral oils such as gasoline or kerosene. It will ruin the rubber parts of the hydraulic system.

**WARNING:**

After cleaning clutch disc, wipe it with a dust collector. Do not use compressed air.

# PREPARATION

Special Service Tools

## Special Service Tools

NFCL0002

The actual shapes of Kent-Moore tools may differ from those of special service tools illustrated here.

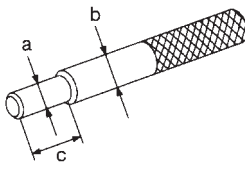
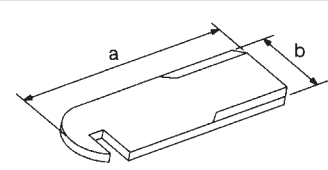
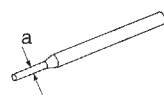
Tool number (Kent-Moore No.) Tool name	Description	
ST20630000 (J26366) Clutch aligning bar	 <p>NT405</p>	Installing clutch cover and clutch disc <b>a: 15.8 mm (0.622 in) dia.</b> <b>b: 22.9 mm (0.902 in) dia.</b> <b>c: 45.0 mm (1.772 in)</b>
ST20050240 ( — ) Diaphragm spring adjusting wrench	 <p>NT404</p>	Adjusting unevenness of diaphragm spring of clutch cover <b>a: 150 mm (5.91 in)</b> <b>b: 25 mm (0.98 in)</b>
KV32101000 (J25689-A) Pin punch	 <p>NT410</p>	Removing and installing spring pin <b>a: 4 mm (0.16 in) dia.</b>

## Commercial Service Tools

NFCL0003

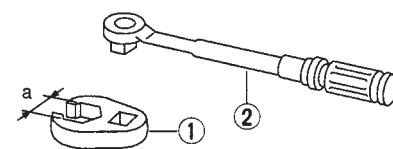
Tool name	Description	
1 Flare nut crowfoot 2 Torque wrench	 <p>NT360</p>	Removing and installing clutch piping <b>a: 10 mm (0.39 in)</b>

# NOISE, VIBRATION AND HARSHNESS (NVH) TROUBLESHOOTING



NVH Troubleshooting Chart

## NVH Troubleshooting Chart

NFCL0004S01

Use the chart below to help you find the cause of the symptom. The numbers indicate the order of the inspection. If necessary, repair or replace these parts.

### CLUTCH

NFCL0004S0101

Symptom		SUSPECTED PARTS (Possible cause)														Reference page						
		CLUTCH PEDAL (Free play out of adjustment)	CLUTCH LINE (Air in line)	MASTER CYLINDER PISTON CUP (Damaged)	OPERATING CYLINDER PISTON CUP (Damaged)	ENGINE MOUNTING (Loose)	RELEASE BEARING (Worn, dirty or damaged)	CLUTCH DISC (Out of true)	CLUTCH DISC (Runout is excessive)	CLUTCH DISC (Lining broken)	CLUTCH DISC (Dirty or burned)	CLUTCH DISC (Oily)	CLUTCH DISC (Worn out)	CLUTCH DISC (Hardened)	CLUTCH DISC (Lack of spline grease)		DIAPHRAGM SPRING (Damaged)	DIAPHRAGM SPRING (Out of tip alignment)	PRESSURE PLATE (Distortion)	FLYWHEEL (Distortion)		
Clutch grabs/chatters	Clutch grabs/chatters					1																
	Clutch pedal spongy		1	2	2																	CL-6
	Clutch noisy						1															CL-7
	Clutch slips	1										2	2									CL-8
	Clutch does not disengage	1	2	3	4				5	5	5	5	5		5	6	6	7				CL-10
																						Refer to EM-57, "Removal and Installation".
																						CL-13
																						CL-15
																						CL-15
																						CL-15
																						CL-15
																						CL-15
																						CL-15
																						CL-15
																						CL-15
																						CL-15
																						CL-16

# CLUTCH SYSTEM

## Components

NFCL0005

SEC. 300-305-306-465

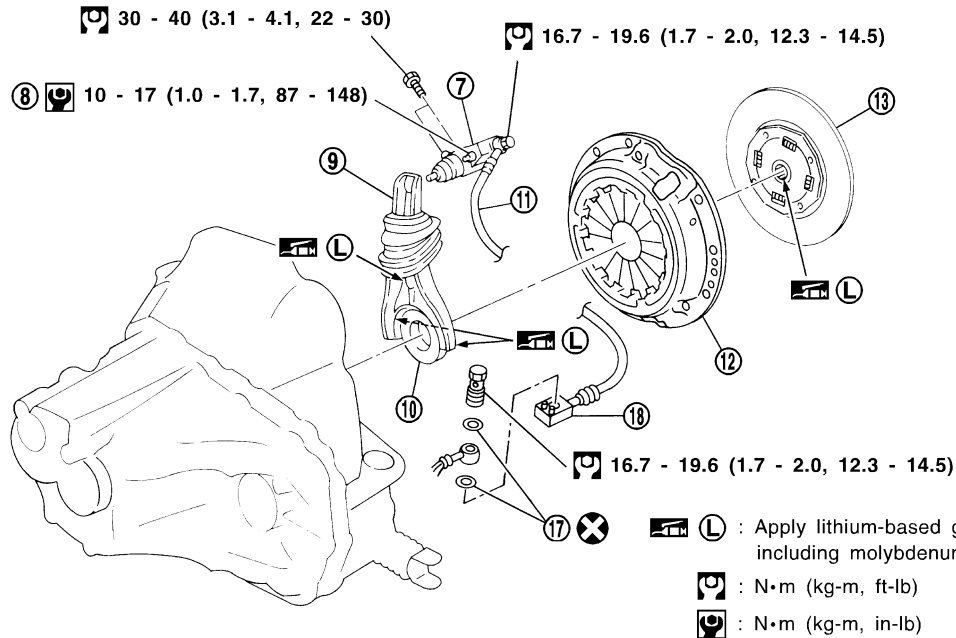
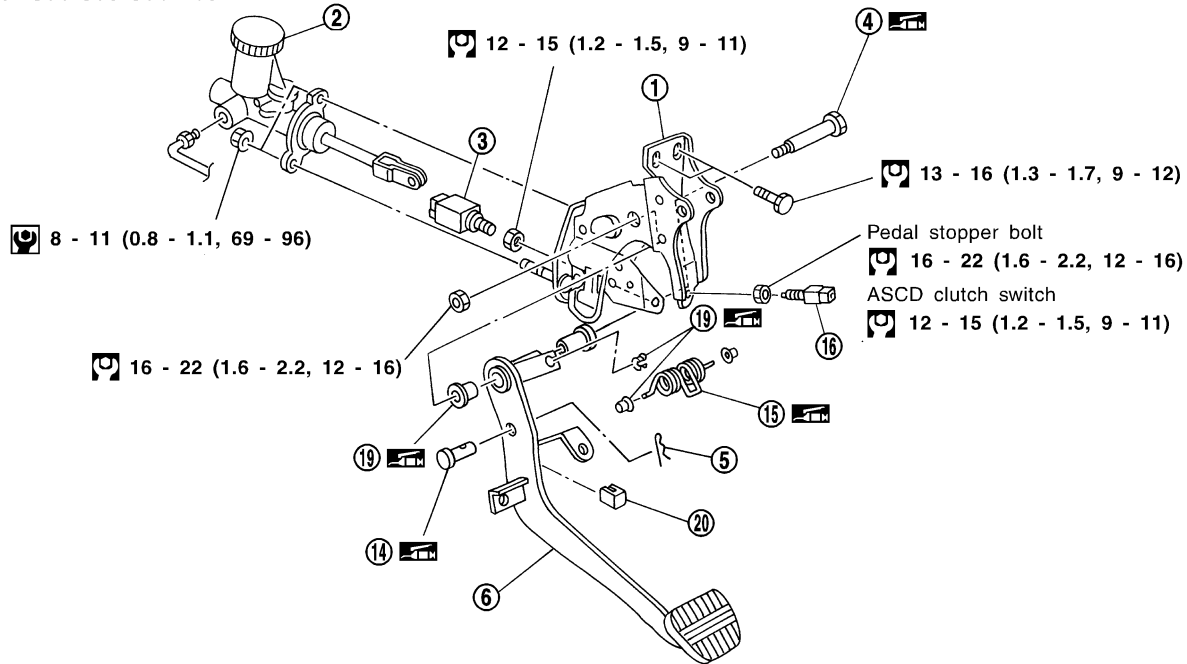

SCL812

- |                            |                      |                           |
|----------------------------|----------------------|---------------------------|
| 1. Pedal bracket           | 8. Air bleeder screw | 15. Assist spring         |
| 2. Clutch master cylinder  | 9. Withdrawal lever  | 16. ASCD clutch switch    |
| 3. Clutch interlock switch | 10. Release bearing  | 17. Washer                |
| 4. Fulcrum pin             | 11. Clutch hose      | 18. Clutch hose connector |
| 5. Pin                     | 12. Clutch cover     | 19. Bushing               |
| 6. Clutch pedal            | 13. Clutch disc      | 20. Stopper rubber        |
| 7. Operating cylinder      | 14. Clevis pin       |                           |

GI  
MA  
EM  
LC  
EC  
FE  
CL  
MT  
AT  
AX  
SU  
BR  
ST  
RS  
BT  
HA  
SC  
EL  
IDX

# CLUTCH SYSTEM

## Inspection and Adjustment

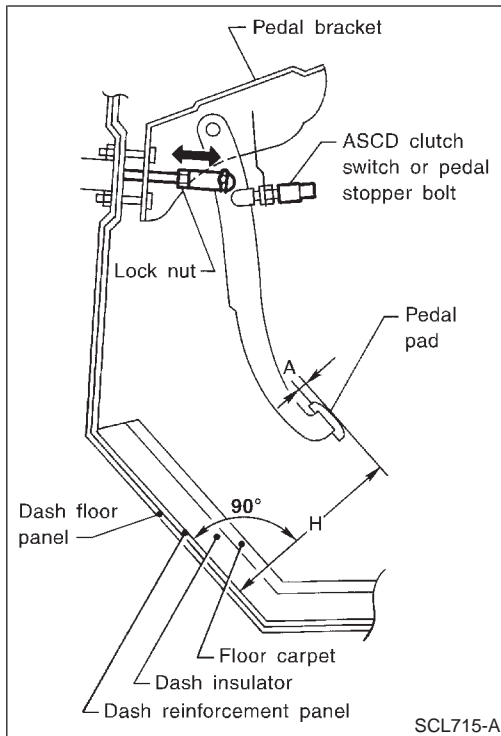

## Inspection and Adjustment

NFCL0006

### ADJUSTING CLUTCH PEDAL

NFCL0006S01

#### Pedal Height

NFCL0006S0101

1. Adjust pedal height with ASCD clutch switch or pedal stopper bolt.

**Pedal height "H":**  
**179.5 - 189.5 mm (7.07 - 7.46 in)**

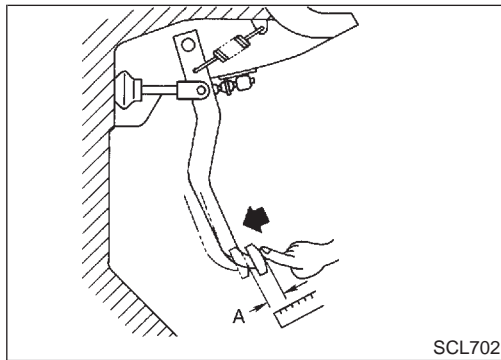

2. Adjust pedal free play with master cylinder push rod. Then tighten lock nut.

**Pedal free play "A":**  
**9 - 16 mm (0.35 - 0.63 in)**

- Push or step on clutch pedal until resistance is felt, and check the distance the pedal moves.

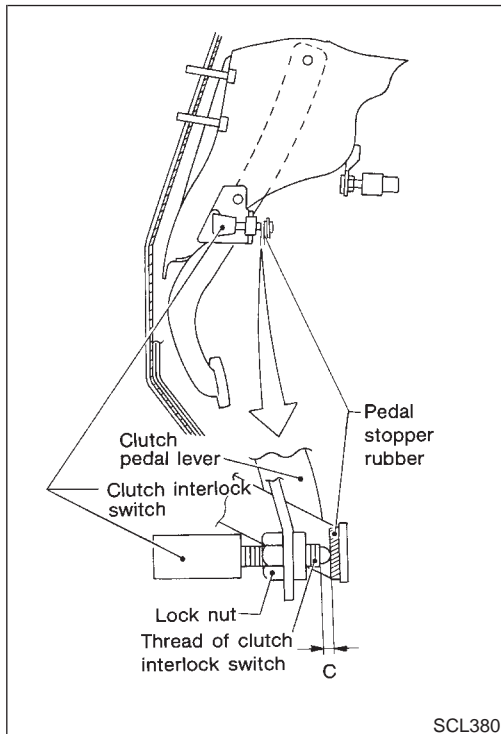

3. Adjust clearance "C" shown in the figure while fully depressing clutch pedal fully.

**Clearance C:**  
**0.1 - 1.5 mm (0.004 - 0.059 in)**

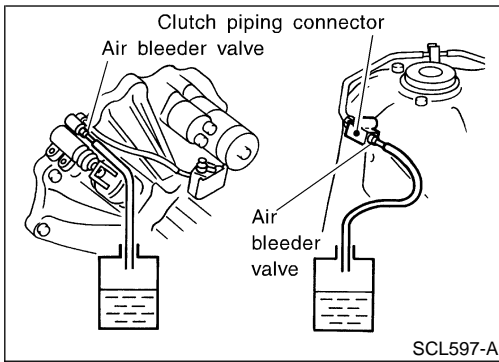

## AIR BLEEDING PROCEDURE

NFCL0006S02

1. Bleed air from clutch piping connector and operating cylinder according to the following procedure.
  - **Carefully monitor fluid level at master cylinder during air bleeding operation.**
  - **Be careful not to splash brake fluid on painted areas; it may cause paint damage. If brake fluid is splashed on painted areas, wash it away with water immediately.**
- a. Top up reservoir of master cylinder with recommended brake fluid.
- b. Connect a transparent vinyl tube to air bleeder valve.
- c. Slowly depress clutch pedal to its full stroke and release it completely. Repeat this operation several times at 2 to 3 second intervals.
- d. Holding clutch pedal depressed, open air bleeder valve to release air.
- e. Close air bleeder valve.
- f. Release clutch pedal and wait at least 5 seconds.
- g. Repeat steps c through f above until brake fluid flows from air bleeder valve without air bubbles.
2. Bleed air from clutch operating cylinder according to the above same procedure.
3. Repeat the above air bleeding procedures 1 and 2 several times.

**Tightening torque of air bleeder valve:**

: 10 - 17 N·m (1.0 - 1.7 kg·m, 87 - 148 in·lb)

GI

MA

EM

LC

EC

FE

**CL**

MT

AT

AX

SU

BR

ST

RS

BT

HA

SC

EL

IDX

# CLUTCH MASTER CYLINDER

Components

## Components

NFCL0007

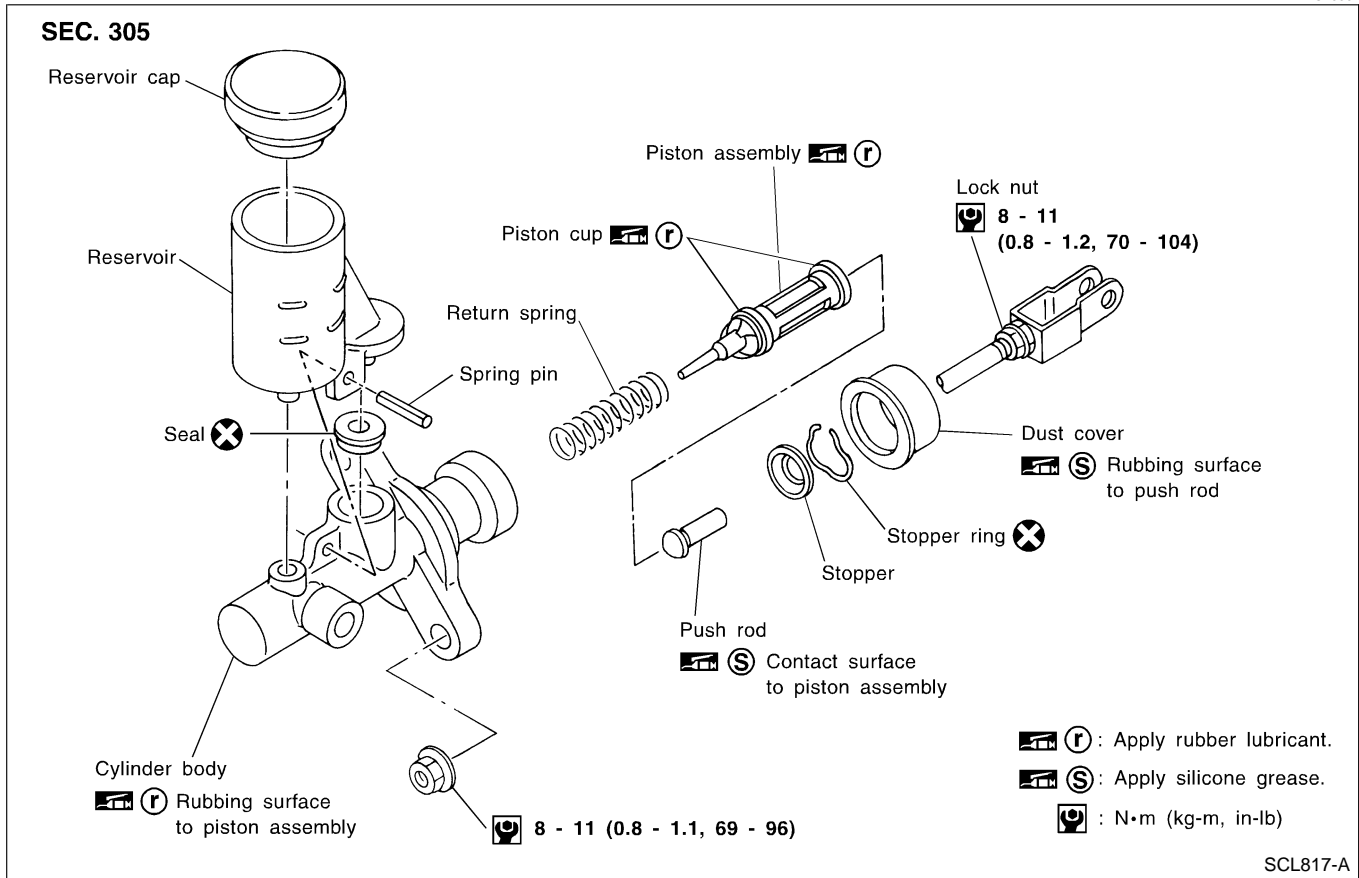

## Removal

NFCL0008

1. Drain brake fluid.

### CAUTION:

**Be careful not to splash brake fluid on painted areas; it may cause paint damage. If brake fluid is splashed on painted areas, wash it away with water immediately.**

2. Remove clutch tube using a flare nut wrench.
3. Remove snap pin between clutch pedal and push rod, and remove clevis pin.
4. Unscrew master cylinder assembly mounting nuts and remove master cylinder assembly from vehicle.

## Installation

NFCL0009

1. Connect clutch tube to master cylinder assembly, and hand-tighten flare nut.
2. Install master cylinder assembly to vehicle, and tighten mounting nuts to the specified torque.

**8 - 11 N•m (0.8 - 1.1 kg-m, 69 - 96 in-lb)**

3. Tighten clutch tube flare nut using a flare nut torque wrench.

**15 - 18 N•m (1.5 - 1.8 kg-m, 11 - 13 ft-lb)**

4. After installing clevis pin, install snap pin to connect clutch pedal to push rod.

CL-8



- After finishing the operation, bleed air from clutch piping connector and operating cylinder. (Refer to "Air Bleeding Procedure", CL-7.)

GI

MA

EM

LC

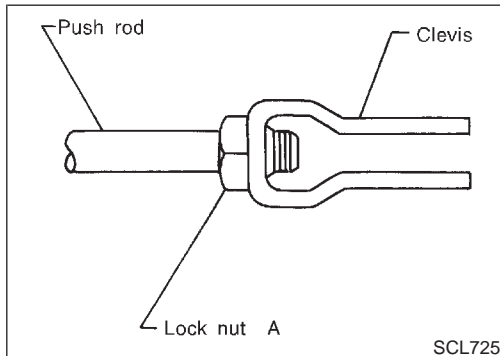

## Disassembly

- Loosen push rod lock nut A to remove clevis and lock nut A. <sup>NFCL0010</sup>
- Remove dust cover. <sup>EC</sup>
- Remove stopper ring and stopper, and remove push rod from cylinder body. During removal, keep push rod depressed, to prevent piston inside master cylinder from popping out. <sup>FE</sup>
- Remove piston assembly from cylinder body. <sup>CL</sup>

CL

MT

## Inspection

Check the following items, and replace if necessary. <sup>NFCL0011</sup>

- Rubbing surface of cylinder and piston, for uneven wear, rust or damage <sup>AT</sup>
- Piston with piston cup, for wear or damage <sup>AX</sup>
- Return spring, for wear or damage <sup>SU</sup>
- Dust cover, for cracks, deformation or damage <sup>BR</sup>
- Reservoir, for deformation or damage

BR

## Assembly

- Apply rubber lubricant to the sliding part of piston assembly, and insert piston assembly. <sup>NFCL0012</sup> <sup>ST</sup>
- After installing stopper to push rod, install stopper ring while keeping piston assembly depressed by hand, so that piston assembly will not pop out. <sup>RS</sup>

BT

### CAUTION:

**Stopper ring cannot be reused. Always use a new stopper ring for assembly.**

HA

- Install dust cover. <sup>SC</sup>
- Install clevis to push rod, and tighten lock nut A to the specified torque.

: 8 - 11 N·m (0.8 - 1.2 kg·m, 70 - 104 in·lb)

SC

- Install spring pin using a pin punch. <sup>EL</sup>

EL

IDX

# OPERATING CYLINDER

Components

## Components

NFCL0019

SEC. 306

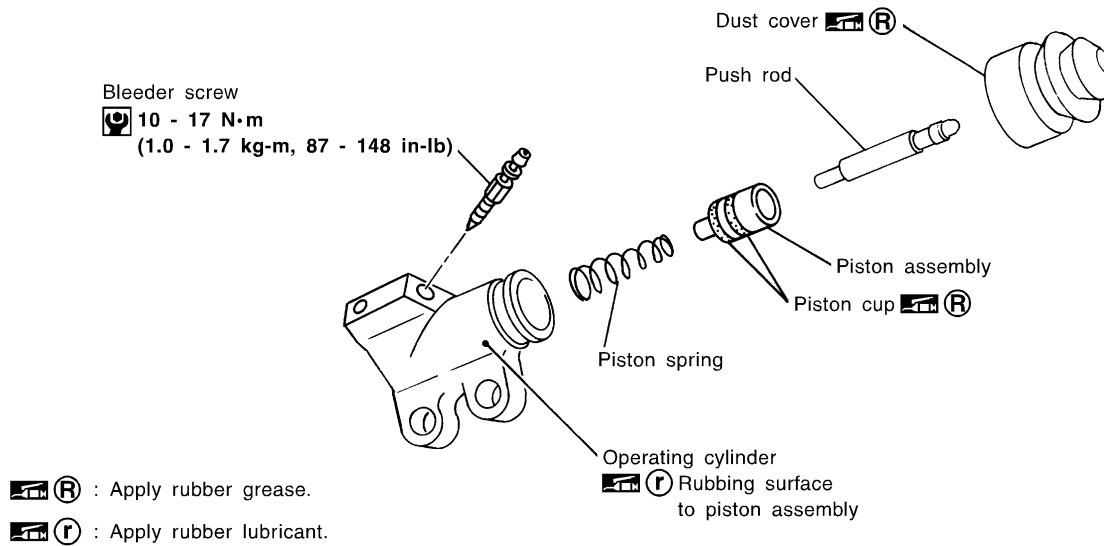

SCL813

## Removal

NFCL0020

1. Drain brake fluid.

### CAUTION:

**Be careful not to splash brake fluid on painted areas; it may cause paint damage. If brake fluid is splashed on painted areas, wash it away with water immediately.**

2. Remove union bolt and clutch hose from operating cylinder.
3. Remove operating cylinder mounting bolts, and remove cylinder from vehicle.

## Disassembly

NFCL0021

Remove dust cover, and remove piston assembly from cylinder body.

## Inspection

NFCL0022

Inspect for following, and replace parts if necessary.

- Damage, foreign material, wear, rust, and pinholes on the cylinder inner surface, piston, and sliding part of piston cup
- Weak spring
- Crack and deformation of dust cover

## Assembly

1. Apply recommended rubber grease to piston cup and piston, and insert piston assembly. NFCL0023
2. Install dust cover.

GI

MA

EM

LC

## Installation

Install the components in the reverse order of removal. Adhere to the operations described below. NFCL0024

EC

### **CAUTION:**

**Install the hose without twisting it.**

FE

- The copper washer of the union bolt should not be reused. Always use a new copper washer for installation.
- After finishing the operation, bleed air from the clutch piping connector and operating cylinder. Refer to “Air Bleeding Procedure”, CL-7.

CL

MT

AT

AX

SU

BR

ST

RS

BT

HA

SC

EL

IDX

## Removal

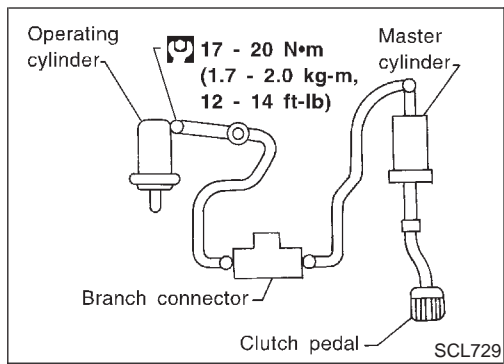

## Removal

NFCL0025

1. Remove fuel filter mounting bracket.
2. Remove air cleaner and air duct. Refer to EM-58, "Removal", "REMOVAL AND INSTALLATION".
3. Drain brake fluid.

### CAUTION:

**Be careful not to splash brake fluid on painted areas; it may cause paint damage. If brake fluid is splashed on painted areas, wash it away with water immediately.**

4. Remove flare nut using a flare nut wrench.
5. Remove clutch hose and clutch tube.

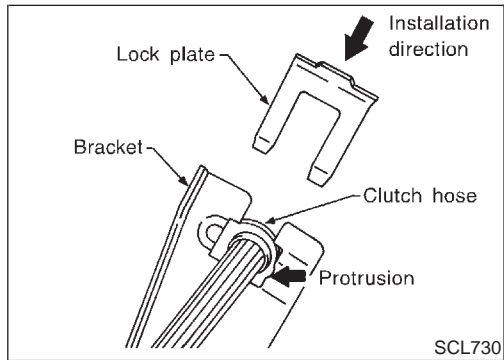

## Installation

NFCL0026

1. When installing clutch hose to bracket, face lock plate in the correct direction as shown to secure clutch hose.

### CAUTION:

**Install clutch hose without twisting or bending it.**

2. Tighten flare nut to the specified torque, using a flare nut wrench.

: 15 - 18 N·m (1.5 - 1.8 kg-m, 11 - 13 ft-lb)

### CAUTION:

**Be careful not to damage flare nut and clutch tube.**

3. Install clutch hose to operating cylinder, and tighten mounting bolts to the specified torque.

: 17 - 20 N·m (1.7 - 2.0 kg-m, 12 - 14 ft-lb)

4. After finishing the operation, bleed air from the clutch piping connector and operating cylinder. Refer to "Air Bleeding Procedure", CL-7.

## Components

NFCL0027

SEC. 321

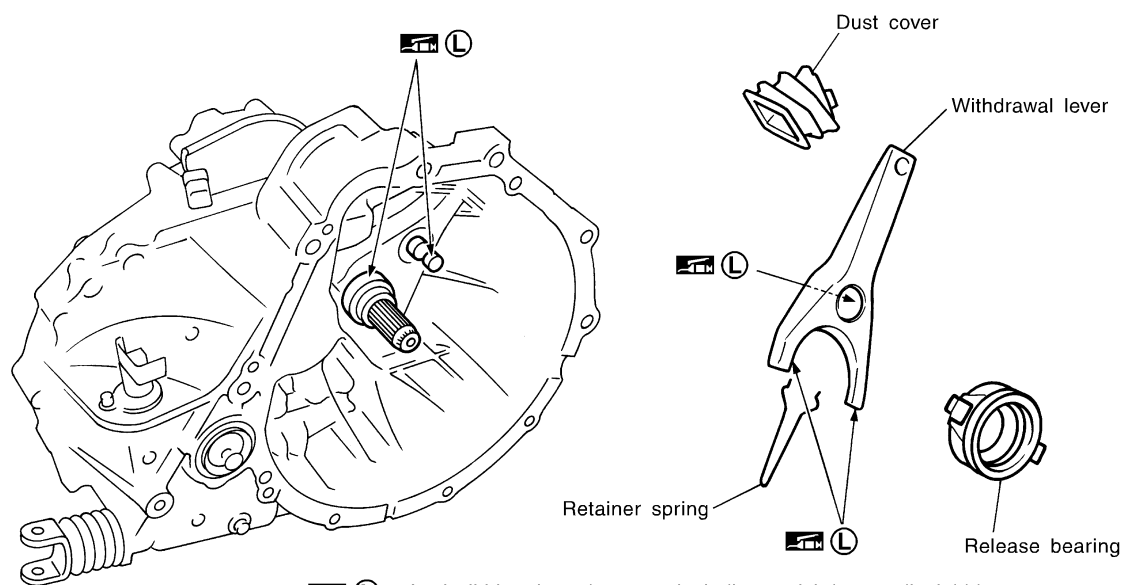

L : Apply lithium-based grease including molybdenum disulphide.

SCL814

GI

MA

EM

LC

EC

FE

CL

MT

## Removal

1. Remove manual transaxle from vehicle. Refer to MT-10, "Removal", "REMOVAL AND INSTALLATION".
2. Move withdrawal lever enough to remove release bearing, and remove release bearing from clutch withdrawal lever.
3. Remove dust cover.
4. Remove retainer spring from withdrawal lever.

NFCL0028

AT

AX

SU

BR

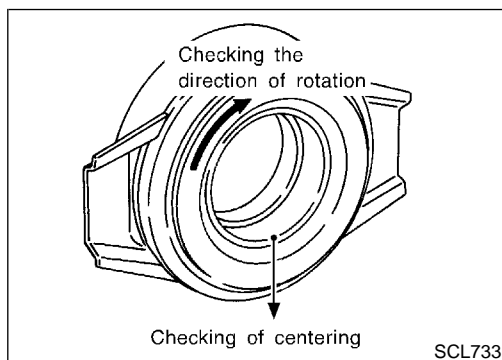

Checking the direction of rotation

Checking of centering

SCL733

## Inspection

- Replace the release bearing if it is seized, damaged, faulty in rotation direction, or has poor aligning function.
- Replace the withdrawal lever if its contact surface is worn abnormally.
- Replace the dust cover if it is deformed or cracked.

NFCL0029

ST

RS

BT

HA

## Installation

1. Apply a coat of grease to parts as instructed in the following cautions and notes before installation.

NFCL0030

SC

EL

**CAUTION:**

- Be sure to apply grease to the clutch components. Otherwise, abnormal noise, poor clutch disengagement, or clutch damage may occur. Wipe the excess grease off completely, because it may cause the clutch components to slip and shudder.
- Keep the clutch disc facing, pressure plate, and flywheel free of oil and grease.

IDX

# CLUTCH RELEASE MECHANISM

Installation (Cont'd)

- Clean old grease and abrasive materials off the grease application area.

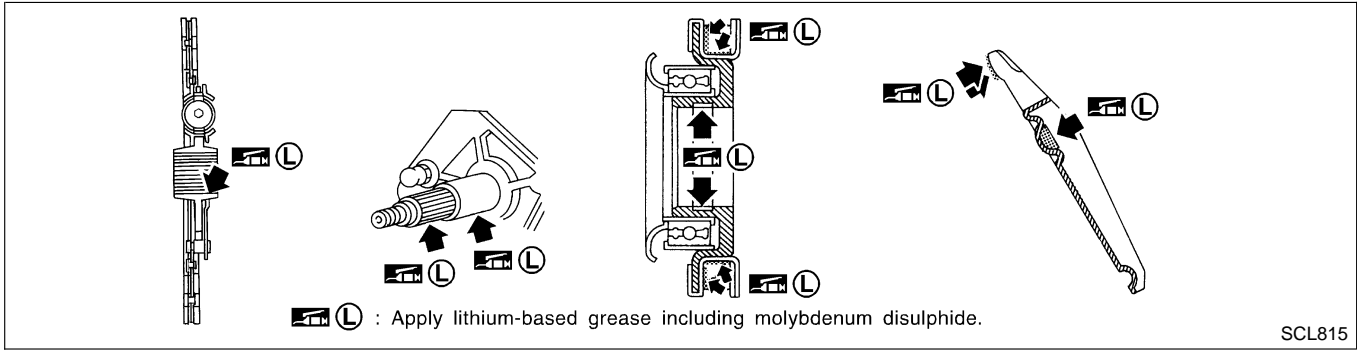

**NOTE:**

- Equally apply a coat [approximately 1 mm (0.04 in) thick] of clutch sleeve grease to withdrawal lever and holder spring frictional surfaces.
  - Apply a coat of clutch sleeve grease to the grooves on contact surfaces of the withdrawal lever ball pin and inner surface of release bearing so that grease application, make sure that grease is flush with grooves.
  - Equally apply a thin coat of clutch sleeve grease to release bearing frictional surface. After grease application, install release bearing. Wipe off excess grease forced out during bearing installation. Remove release bearing.
2. Installation is in the reverse order of removal.

## Components

NFCL0031

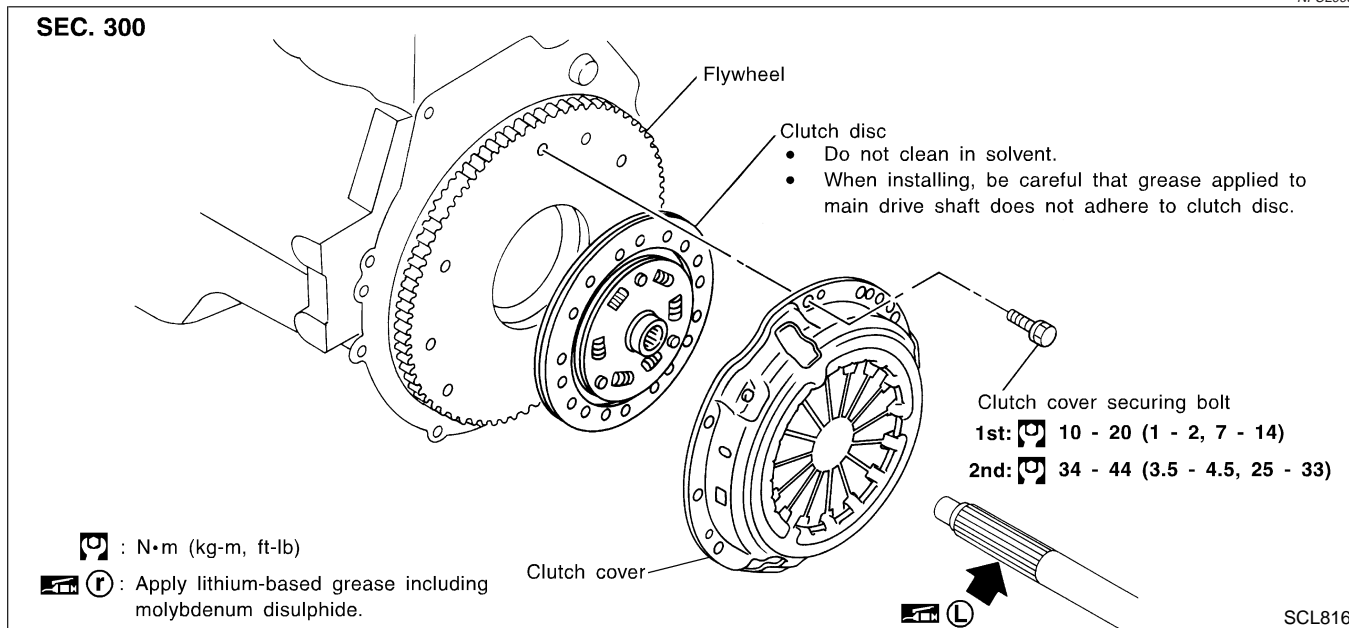

GI  
MA  
EM  
LC  
EC  
FE  
CL

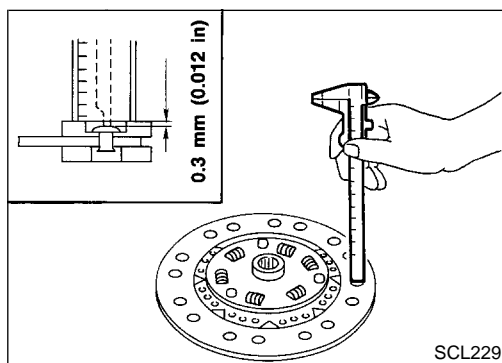

## Inspection and Adjustment

### CLUTCH DISC

NFCL0032

NFCL0032S01

- Check clutch disc for wear of facing.  
**Wear limit of facing surface to rivet head:  
0.3 mm (0.012 in)**

AT  
AX

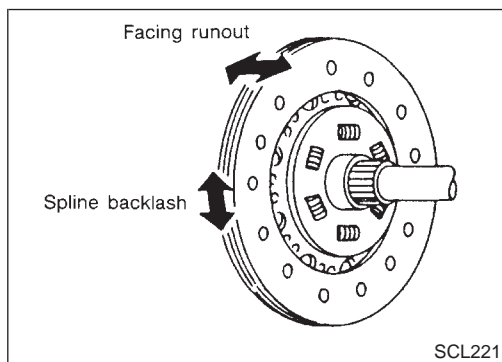

- Check clutch disc for backlash of spline and runout of facing.  
**Maximum spline backlash (at outer edge of disc):  
1.0 mm (0.039 in)**  
**Runout limit:  
1.0 mm (0.039 in)**  
**Distance of runout check point (from hub center):  
115 mm (4.53 in)**
- Check clutch disc for burns, discoloration or oil or grease leakage. Replace if necessary.

SU  
BR

ST  
RS

BT  
HA

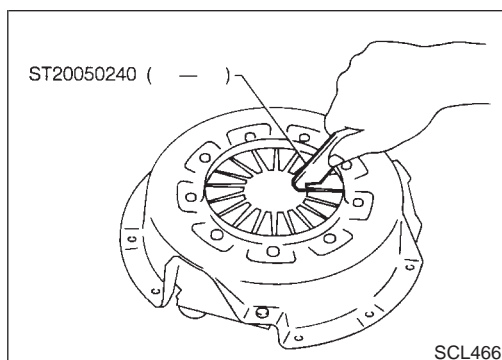

### CLUTCH COVER

NFCL0032S02

- Check clutch cover installed on vehicle for unevenness of diaphragm spring toe height.  
**Uneven limit:  
0.5 mm (0.020 in)**
- If out of limit, adjust the height with Tool.

SC  
EL  
IDX

# CLUTCH DISC, CLUTCH COVER AND FLYWHEEL

Inspection and Adjustment (Cont'd)

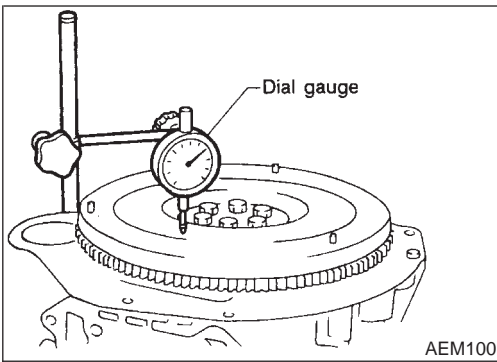

## FLYWHEEL

- Check contact surface of flywheel for slight burns or discoloration. Repair flywheel with emery paper. NFCL0032S03
- Check flywheel runout.

### Maximum allowable runout:

Refer to EM-68, "Flywheel/drive plate runout", "CYLINDER BLOCK".

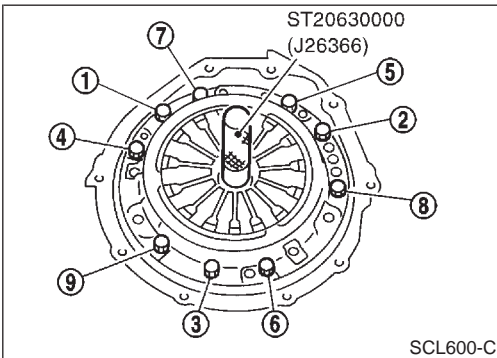

## Installation

- Insert Tool into clutch disc hub when installing clutch cover and disc. NFCL0033
- Be careful not to allow grease to contaminate clutch facing.
- Tighten bolts in numerical order.

### First step:

: 10 - 20 N·m (1 - 2 kg-m, 7 - 14 ft-lb)

### Final step:

: 34 - 44 N·m (3.5 - 4.5 kg-m, 25 - 33 ft-lb)



# SERVICE DATA AND SPECIFICATIONS (SDS)

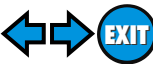

Clutch Control System

## Clutch Control System

NFCL0034

Type of clutch control	Hydraulic	GI
------------------------	-----------	----

## Clutch Master Cylinder

NFCL0035

Unit: mm (in)

MA

Inner diameter	15.87 (5/8)	EM
----------------	-------------	----

## Clutch Operating Cylinder

NFCL0036

Unit: mm (in)

LC

Inner diameter	19.05 (3/4)	EC
----------------	-------------	----

## Clutch Disc

NFCL0038

Model	240	FE
Facing size (Outer dia. × inner dia. × thickness)	240 mm × 160 mm × 3.5 mm (9.45 in × 6.30 in × 0.138 in)	CL
Thickness of disc assembly With load	7.9 mm - 8.3 mm (0.311 in - 0.327 in) with 5,688 N (580 kg, 1,279 lb)	MT
Wear limit of facing surface to rivet head	0.3 mm (0.012 in)	AT
Facing runout limit	1.0 mm (0.039 in)	
Distance of runout check point (from the hub center)	115 mm (4.53 in)	
Maximum spline backlash (at outer edge of disc)	1.0 mm (0.039 in)	

## Clutch Cover

NFCL0039

Model	240	AX
Set load	5,688 N (580 kg, 1,279 lb)	SU
Uneven limit of diaphragm spring toe height	0.5 mm (0.020 in)	

## Clutch Pedal

NFCL0040

Unit: mm (in)

BR

Pedal height*	179.5 - 189.5 (7.07 - 7.46)	ST
Pedal free play	9 - 16 (0.35 - 0.63)	RS
Clearance between pedal stopper rubber and clutch interlock switch threaded end while clutch pedal is fully depressed.	0.1 - 1.5 (0.004 - 0.059)	

\*: Measured from surface of dash reinforcement panel to surface of pedal pad

BT

HA

SC

EL

IDX

## NOTES