

BODY & TRIM

SECTION BT

GI
MA
EM
LC
EC
FE
CL
MT
AT
AX
SU
BR
ST
RS
BT
HA
SC
EL
IDX

CONTENTS

PRECAUTIONS	3	RESET PROCEDURES	21
Service Notice.....	3	Rear Door Glass.....	22
Supplemental Restraint System (SRS) "AIR BAG" and "SEAT BELT PRE-TENSIONER"	3	REAR DOOR GLASS AND REGULATOR	22
PREPARATION	4	Front Door Lock.....	24
Special Service Tools	4	BELL CRANK ADJUSTMENT	24
Commercial Service Tools	4	OUTSIDE HANDLE ROD ADJUSTMENT	24
SQUEAK AND RATTLE TROUBLE DIAGNOSES	5	REMOVAL.....	25
Work Flow.....	5	Rear Door Lock	26
CUSTOMER INTERVIEW	5	OUTSIDE HANDLE ROD ADJUSTMENT	26
DUPLICATE THE NOISE AND TEST DRIVE	6	REMOVAL.....	27
CHECK RELATED SERVICE BULLETINS	6	INSTRUMENT PANEL ASSEMBLY	28
LOCATE THE NOISE AND IDENTIFY THE ROOT CAUSE	6	Removal and Installation	28
REPAIR THE CAUSE	6	SIDE AND FLOOR TRIM	32
CONFIRM THE REPAIR.....	7	Removal and Installation	32
Generic Squeak and Rattle Troubleshooting	7	DOOR TRIM	35
INSTRUMENT PANEL.....	7	Removal and Installation	35
CENTER CONSOLE	7	ROOF TRIM	37
DOORS.....	7	Removal and Installation	37
TRUNK	8	TRUNK ROOM TRIM	39
SUNROOF/HEADLINER	8	Removal and Installation	39
SEATS.....	8	EXTERIOR	40
UNDERHOOD	8	Removal and Installation	40
Diagnostic Worksheet.....	9	FRONT SEAT	46
CLIP AND FASTENER	11	Removal and Installation	46
Description	11	POWER SEAT.....	47
BODY FRONT END	13	MANUAL SEAT.....	48
Removal and Installation	13	HEATED SEAT	49
FRONT BUMPER ASSEMBLY	13	REAR SEAT	50
BODY REAR END AND OPENER	16	Removal and Installation	50
Removal and Installation	16	SUNROOF	51
REAR BUMPER ASSEMBLY	16	Adjustment.....	51
DOOR	19	Removal.....	51
Adjustment.....	19	Trouble Diagnoses.....	55
STRIKER ADJUSTMENT	19	DIAGNOSTIC TABLE.....	55
Front Door Glass	20	WIND DEFLECTOR	55
FRONT DOOR GLASS AND REGULATOR	20	ADJUSTMENT	56
Front Door Limit Switch Reset (Driver side only).....	21	DRAIN HOSES	57
RESET CONDITIONS	21	WEATHERSTRIP	57
		LINK AND WIRE ASSEMBLY.....	58
		WINDSHIELD AND WINDOWS	59

CONTENTS (Cont'd)

Removal and Installation	59	Removal and Installation	62
REMOVAL.....	59	REMOVAL.....	62
INSTALLATION.....	59	INSTALLATION.....	62
WINDSHIELD	60	BODY (ALIGNMENT)	63
DOOR MIRROR	61	Alignment	63
Removal and Installation	61	ENGINE COMPARTMENT.....	64
REAR VIEW MIRROR	62	UNDERBODY	66

Service Notice

NFBT0001

- When removing or installing various parts, place a cloth or padding onto the vehicle body to prevent scratches.
- Handle trim, molding, instruments, grille, etc. carefully during removing or installing. Be careful not to soil or damage them.
- Apply sealing compound where necessary when installing parts.
- When applying sealing compound, be careful that the sealing compound does not protrude from parts.
- When replacing any metal parts (for example body outer panel, members, etc.), be sure to take rust prevention measures.

GI

MA

EM

Supplemental Restraint System (SRS) “AIR BAG” and “SEAT BELT PRE-TENSIONER”

NFBT0002

The Supplemental Restraint System such as “AIR BAG” and “SEAT BELT PRE-TENSIONER” used along with a seat belt, helps to reduce the risk or severity of injury to the driver and front passenger for certain types of collision. The SRS system composition which is available to NISSAN MODEL A33 is as follows (The composition varies according to optional equipment.):

EC

FE

- For a frontal collision
The Supplemental Restraint System consists of driver air bag module (located in the center of the steering wheel), front passenger air bag module (located on the instrument panel on passenger side), seat belt pre-tensioners, a diagnosis sensor unit, warning lamp, wiring harness and spiral cable.
- For a side collision
The Supplemental Restraint System consists of front side air bag module (located in the outer side of front seat), satellite sensor, diagnosis sensor unit (one of components of air bags for a frontal collision), wiring harness, warning lamp (one of components of air bags for a frontal collision).

CL

MT

Information necessary to service the system safely is included in the **RS section** of this Service Manual.

AT

WARNING:

- **To avoid rendering the SRS inoperative, which could increase the risk of personal injury or death in the event of a collision which would result in air bag inflation, all maintenance should be performed by an authorized NISSAN dealer.**
- **Improper maintenance, including incorrect removal and installation of the SRS, can lead to personal injury caused by intentional activation of the system. For removal of Spiral Cable and Air Bag Module, see the RS section.**
- **Do not use electrical test equipment on any circuit related to the SRS unless instructed to in this Service Manual. Spiral cable and wiring harnesses covered with yellow insulation or tape either just before the harness connectors or for the complete harness are related to the SRS.**

AX

SU

BR

ST

RS

BT

HA

SC

EL

IDX

PREPARATION

Special Service Tools

Special Service Tools

NFBT0027

The actual shapes of Kent-Moore tools may differ from those of special service tools illustrated here.

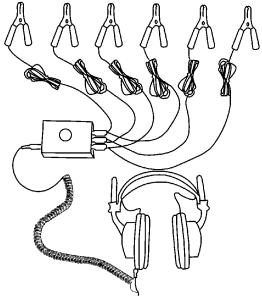
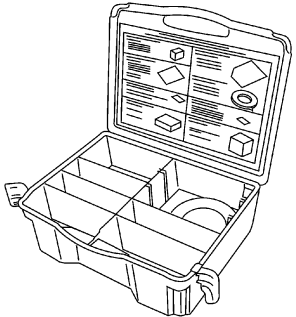
Tool number (Kent-Moore No.) Tool name	Description
<p>— (J-39570) Chassis ear</p>	<p>Locating the noise</p>  <p>SBT839</p>
<p>— (J-43980) Nissan Squeak and Rattle kit</p>	<p>Repairing the cause of noise</p>  <p>SBT840</p>

Commercial Service Tools

NFBT0028

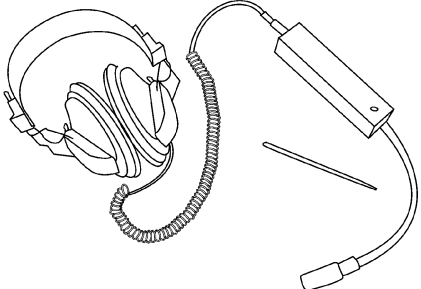
Tool name	Description
<p>Engine ear</p>	<p>Locating the noise</p>  <p>SBT841</p>

Work Flow

NFBT0029

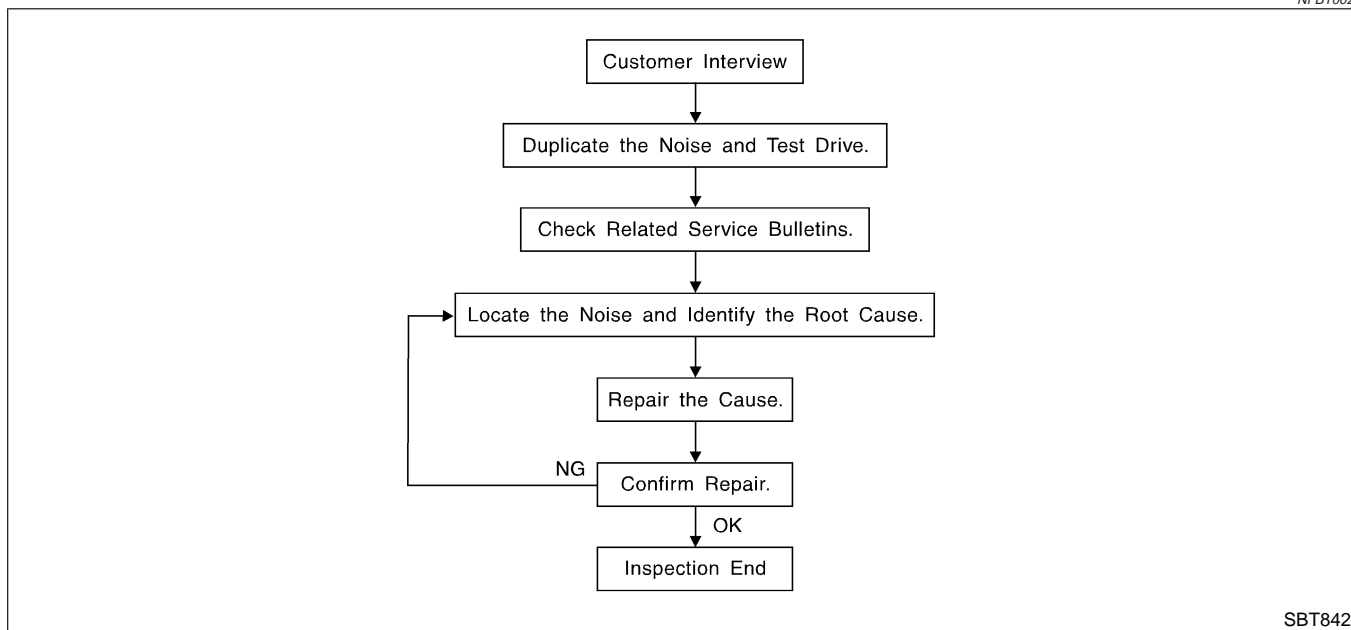

SBT842

CUSTOMER INTERVIEW

NFBT0029S01

Interview the customer, if possible, to determine the conditions that exist when the noise occurs. Use the Diagnostic Worksheet during the interview to document the facts and conditions when the noise occurs and any customer's comments; refer to BT-9. This information is necessary to duplicate the conditions that exist when the noise occurs.

- The customer may not be able to provide a detailed description or the location of the noise. Attempt to obtain all the facts and conditions that exist when the noise occurs (or does not occur).
- If there is more than one noise in the vehicle, be sure to diagnose and repair the noise that the customer is concerned about. This can be accomplished by test driving the vehicle with the customer.
- After identifying the type of noise, isolate the noise in terms of its characteristics. The noise characteristics are provided so the customer, service adviser and technician are all speaking the same language when defining the noise.
- Squeak — (Like tennis shoes on a clean floor)
Squeak characteristics include the light contact/fast movement/brought on by road conditions/hard surfaces = higher pitch noise/softer surfaces = lower pitch noises/edge to surface = chirping
- Creak — (Like walking on an old wooden floor)
Creak characteristics include firm contact/slow movement/twisting with a rotational movement/pitch dependent on materials/often brought on by activity.
- Rattle — (Like shaking a baby rattle)
Rattle characteristics include the fast repeated contact/vibration or similar movement/loose parts/missing clip or fastener/incorrect clearance.
- Knock — (Like a knock on a door)
Knock characteristics include hollow sounding/sometimes repeating/often brought on by driver action.
- Tick — (Like a clock second hand)
Tick characteristics include gentle contacting of light materials/loose components/can be caused by driver action or road conditions.
- Thump — (Heavy, muffled knock noise)
Thump characteristics include softer knock/dead sound often brought on by activity.
- Buzz — (Like a bumble bee)
Buzz characteristics include high frequency rattle/firm contact.
- Often the degree of acceptable noise level will vary depending upon the person. A noise that you may judge as acceptable may be very irritating to the customer.
- Weather conditions, especially humidity and temperature, may have a great effect on noise level.

SQUEAK AND RATTLE TROUBLE DIAGNOSES

Work Flow (Cont'd)

DUPLICATE THE NOISE AND TEST DRIVE

NFBT0029S02

If possible, drive the vehicle with the customer until the noise is duplicated. Note any additional information on the Diagnostic Worksheet regarding the conditions or location of the noise. This information can be used to duplicate the same conditions when you confirm the repair.

If the noise can be duplicated easily during the test drive, to help identify the source of the noise, try to duplicate the noise with the vehicle stopped by doing one or all of the following:

- 1) Close a door.
 - 2) Tap or push/pull around the area where the noise appears to be coming from.
 - 3) Rev the engine.
 - 4) Use a floor jack to recreate vehicle "twist".
 - 5) At idle, apply engine load (electrical load, half-clutch on M/T model, drive position on A/T model).
 - 6) Raise the vehicle on a hoist and hit a tire with a rubber hammer.
- Drive the vehicle and attempt to duplicate the conditions the customer states exist when the noise occurs.
 - If it is difficult to duplicate the noise, drive the vehicle slowly on an undulating or rough road to stress the vehicle body.

CHECK RELATED SERVICE BULLETINS

NFBT0029S03

After verifying the customer concern or symptom, check ASIST for Technical Service Bulletins (TSBs) related to that concern or symptom.

If a TSB relates to the symptom, follow the procedure to repair the noise.

LOCATE THE NOISE AND IDENTIFY THE ROOT CAUSE

NFBT0029S04

1. Narrow down the noise to a general area. To help pinpoint the source of the noise, use a listening tool (Chassis Ear: J-39570, Engine Ear: J-39565 and mechanics stethoscope).
2. Narrow down the noise to a more specific area and identify the cause of the noise by:
 - removing the components in the area that you suspect the noise is coming from.
Do not use too much force when removing clips and fasteners, otherwise clips and fastener can be broken or lost during the repair, resulting in the creation of new noise.
 - tapping or pushing/pulling the component that you suspect is causing the noise.
Do not tap or push/pull the component with excessive force, otherwise the noise will be eliminated only temporarily.
 - feeling for a vibration with your hand by touching the component(s) that you suspect is (are) causing the noise.
 - placing a piece of paper between components that you suspect are causing the noise.
 - looking for loose components and contact marks.

Refer to "Generic Squeak and Rattle Troubleshooting", BT-7.

REPAIR THE CAUSE

NFBT0029S05

- If the cause is a loose component, tighten the component securely.
- If the cause is insufficient clearance between components:
 - separate components by repositioning or loosening and retightening the component, if possible.
 - insulate components with a suitable insulator such as urethane pads, foam blocks, felt cloth tape or urethane tape. A Nissan Squeak and Rattle Kit (J-43980) is available through your authorized Nissan Parts Department.

CAUTION:

Do not use excessive force as many components are constructed of plastic and may be damaged. Always check with the Parts Department for the latest parts information.

The following materials are contained in the Nissan Squeak and Rattle Kit (J-43980). Each item can be ordered separately as needed.

URETHANE PADS [1.5 mm (0.059 in) thick]

Insulates connectors, harness, etc.

76268-9E005: 100 x 135 mm (3.94 x 5.31 in)/76884-71L01: 60 x 85 mm (2.36 x 3.35 in)/76884-71L02: 15 x 25 mm (0.59 x 0.98 in)

INSULATOR (Foam blocks)

Insulates components from contact. Can be used to fill space behind a panel.

73982-9E000: 45 mm (1.77 in) thick, 50 x 50 mm (1.97 x 1.97 in)/73982-50Y00: 10 mm (0.39 in) thick, 50 x 50 mm (1.97 x 1.97 in)

INSULATOR (Light foam block)

80845-71L00: 30 mm (1.18 in) thick, 30 x 50 mm (1.18 x 1.97 in)

FELT CLOTH TAPE

Used to insulate where movement does not occur. Ideal for instrument panel applications.

68370-4B000: 15 x 25 mm (0.59 x 0.98 in) pad/68239-13E00: 5 mm (0.20 in) wide tape roll

The following materials, not found in the kit, can also be used to repair squeaks and rattles.

UHMW (TEFLON) TAPE

Insulates where slight movement is present. Ideal for instrument panel applications.

SILICONE GREASE

Used in place of UHMW tape that will be visible or not fit.

Note: Will only last a few months.

SILICONE SPRAY

Use when grease cannot be applied.

DUCT TAPE

Use to eliminate movement.

CONFIRM THE REPAIR

Confirm that the cause of a noise is repaired by test driving the vehicle. Operate the vehicle under the same conditions as when the noise originally occurred. Refer to the notes on the Diagnostic Worksheet.

Generic Squeak and Rattle Troubleshooting

Refer to Table of Contents for specific component removal and installation information.

INSTRUMENT PANEL

Most incidents are caused by contact and movement between:

1. The cluster lid A and instrument panel
2. Acrylic lens and combination meter housing
3. Instrument panel to front pillar garnish
4. Instrument panel to windshield
5. Instrument panel mounting pins
6. Wiring harnesses behind the combination meter
7. A/C defroster duct and duct joint

These incidents can usually be located by tapping or moving the components to duplicate the noise or by pressing on the components while driving to stop the noise. Most of these incidents can be repaired by applying felt cloth tape or silicon spray (in hard to reach areas). Urethane pads can be used to insulate wiring harness.

CAUTION:

Do not use silicone spray to isolate a squeak or rattle. If you saturate the area with silicone, you will not be able to recheck the repair.

CENTER CONSOLE

Components to pay attention to include:

1. Shifter assembly cover to finisher
2. A/C control unit and cluster lid C
3. Wiring harnesses behind audio and A/C control unit

The instrument panel repair and isolation procedures also apply to the center console.

DOORS

Pay attention to the:

1. Finisher and inner panel making a slapping noise
2. Inside handle escutcheon to door finisher
3. Wiring harnesses tapping
4. Door striker out of alignment causing a popping noise on starts and stops

Tapping or moving the components or pressing on them while driving to duplicate the conditions can isolate many of these incidents. You can usually insulate the areas with felt cloth tape or insulator foam blocks from the Nissan Squeak and Rattle Kit (J-43980) to repair the noise.

GI

MA

EM

LC

EC

FE

CL

MT

AT

AX

SU

BR

ST

RS

BT

HA

SC

EL

IDX

SQUEAK AND RATTLE TROUBLE DIAGNOSES

Generic Squeak and Rattle Troubleshooting (Cont'd)

TRUNK

=NFBT0030S04

Trunk noises are often caused by a loose jack or loose items put into the trunk by the owner. In addition look for:

1. Trunk lid bumpers out of adjustment
2. Trunk lid striker out of adjustment
3. The trunk lid torsion bars knocking together
4. A loose license plate or bracket

Most of these incidents can be repaired by adjusting, securing or insulating the item(s) or component(s) causing the noise.

SUNROOF/HEADLINER

NFBT0030S05

Noises in the sunroof/headliner area can often be traced to one of the following:

1. Sunroof lid, rail, linkage or seals making a rattle or light knocking noise
2. Sunvisor shaft shaking in the holder
3. Front or rear windshield touching headliner and squeaking

Again, pressing on the components to stop the noise while duplicating the conditions can isolate most of these incidents. Repairs usually consist of insulating with felt cloth tape.

SEATS

NFBT0030S06

When isolating seat noises it's important to note the position the seat is in and the load placed on the seat when the noise is present. These conditions should be duplicated when verifying and isolating the cause of the noise.

Cause of seat noise include:

1. Headrest rods and holders
2. A squeak between the seat pad cushion and frame
3. The rear seat back lock and bracket

These noises can be isolated by moving or pressing on the suspected components while duplicating the conditions under which the noise occurs. Most of these incidents can be repaired by repositioning the component or applying urethane tape to the contact area.

UNDERHOOD

NFBT0030S07

Some interior noises may be caused by components under the hood or on the engine wall. The noise is then transmitted into the passenger compartment.

Causes of transmitted underhood noises include:

1. Any component mounted to the engine wall
2. Components that pass through the engine wall
3. Engine wall mounts and connectors
4. Loose radiator mounting pins
5. Hood bumpers out of adjustment
6. Hood striker out of adjustment

These noises can be difficult to isolate since they cannot be reached from the interior of the vehicle. The best method is to secure, move or insulate one component at a time and test drive the vehicle. Also, engine RPM or load can be changed to isolate the noise. Repairs can usually be made by moving, adjusting, securing, or insulating the component causing the noise.

Diagnostic Worksheet

NFBT0031



SQUEAK & RATTLE DIAGNOSTIC WORKSHEET

Dear Nissan Customer:

We are concerned about your satisfaction with your Nissan vehicle. Repairing a squeak or rattle sometimes can be very difficult. To help us fix your Nissan right the first time, please take a moment to note the area of the vehicle where the squeak or rattle occurs and under what conditions. You may be asked to take a test drive with a service advisor or technician to ensure we confirm the noise you are hearing.

I. WHERE DOES THE NOISE COME FROM? (circle the area of the vehicle)

The illustrations are for reference only, and may not reflect the actual configuration of your vehicle.

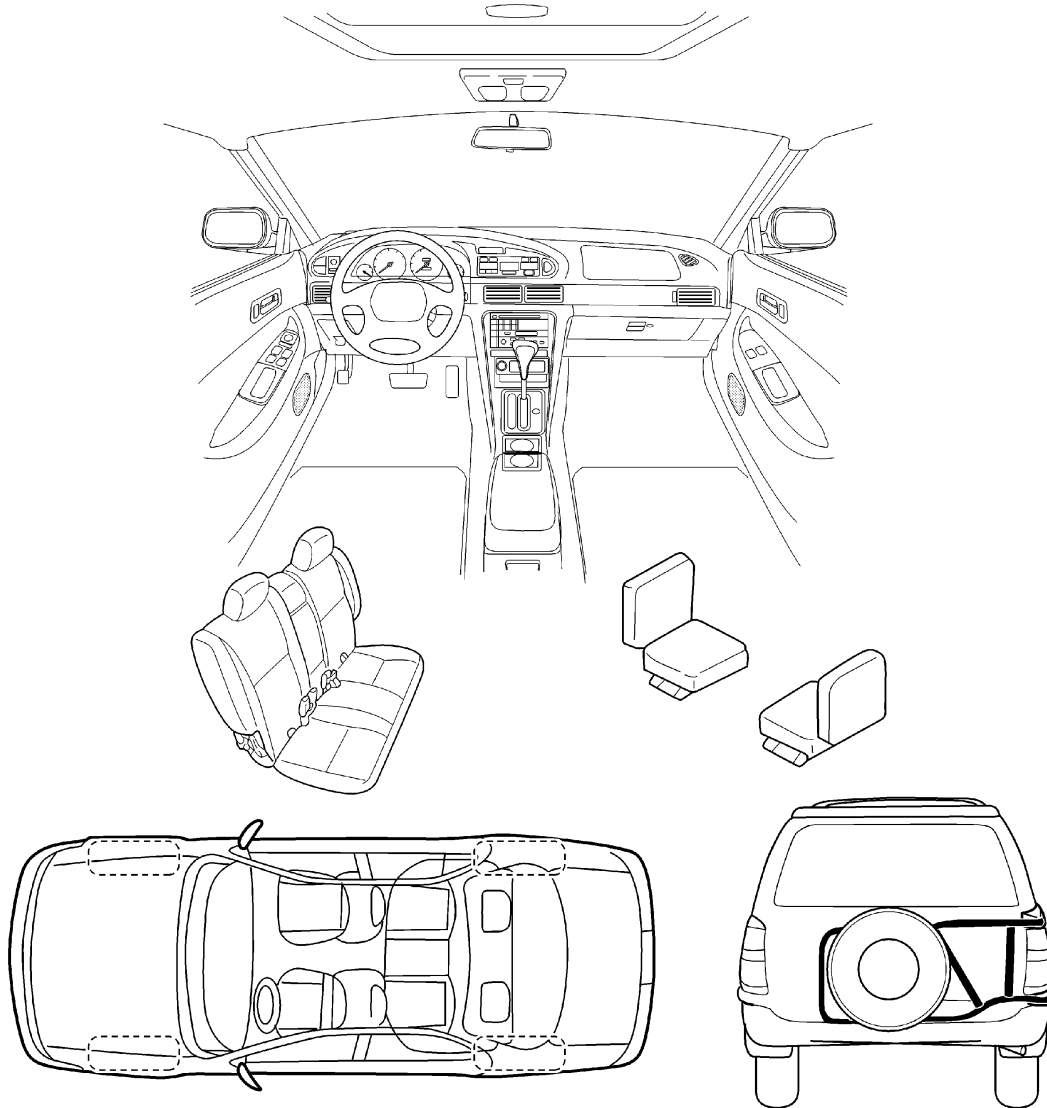

Continue to the back of the worksheet and briefly describe the location of the noise or rattle. In addition, please indicate the conditions which are present when the noise occurs.

GI

MA

EM

LC

EC

FE

CL

MT

AT

AX

SU

BR

ST

RS

BT

HA

SC

EL

IDX

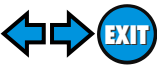

SQUEAK AND RATTLE TROUBLE DIAGNOSES

Diagnostic Worksheet (Cont'd)

SQUEAK & RATTLE DIAGNOSTIC WORKSHEET- page 2

Briefly describe the location where the noise occurs:

II. WHEN DOES IT OCCUR? (check the boxes that apply)

- anytime
- 1st time in the morning
- only when it is cold outside
- only when it is hot outside
- after sitting out in the sun
- when it is raining or wet
- dry or dusty conditions
- other: _____

III. WHEN DRIVING:

- through driveways
- over rough roads
- over speed bumps
- only at about ____ mph
- on acceleration
- coming to a stop
- on turns : left, right or either (circle)
- with passengers or cargo
- other: _____
- after driving ____ miles or ____ minutes

IV. WHAT TYPE OF NOISE?

- squeak (like tennis shoes on a clean floor)
- creak (like walking on an old wooden floor)
- rattle (like shaking a baby rattle)
- knock (like a knock on a door)
- tick (like a clock second hand)
- thump (heavy, muffled knock noise)
- buzz (like a bumble bee)

TO BE COMPLETED BY DEALERSHIP PERSONNEL

Test Drive Notes:

	<u>YES</u>	<u>NO</u>	<u>Initials of person performing</u>
Vehicle test driven with customer	<input type="checkbox"/>	<input type="checkbox"/>	_____
- Noise verified on test drive	<input type="checkbox"/>	<input type="checkbox"/>	_____
- Noise source located and repaired	<input type="checkbox"/>	<input type="checkbox"/>	_____
- Follow up test drive performed to confirm repair	<input type="checkbox"/>	<input type="checkbox"/>	_____

VIN: _____ Customer Name: _____

W.O. #: _____ Date: _____

This form must be attached to Work Order







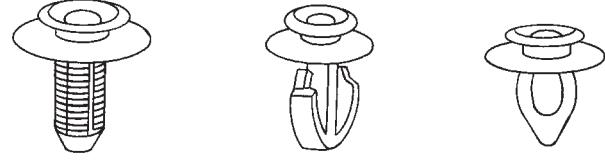

CLIP AND FASTENER

Description

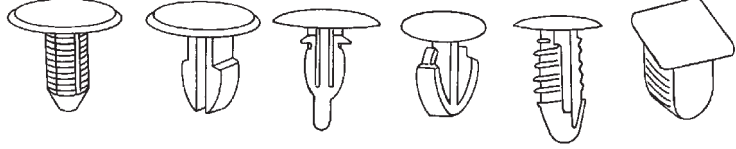
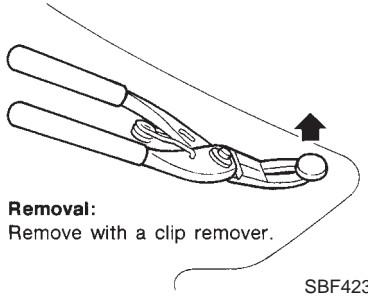
Description

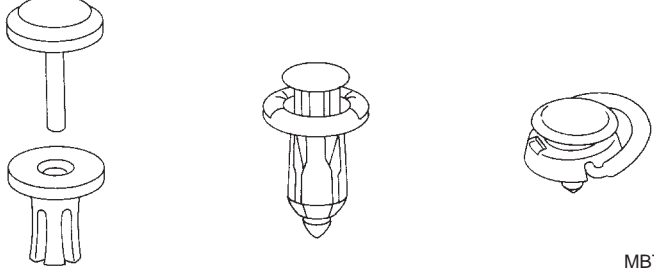
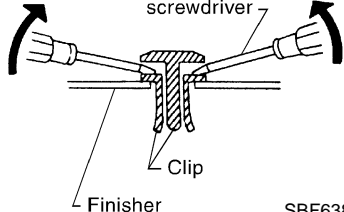
NFBT0003

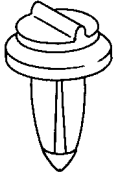
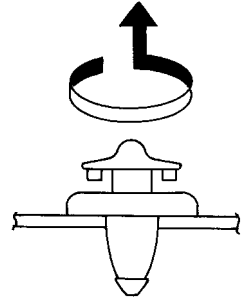

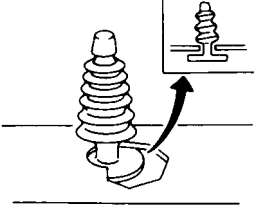
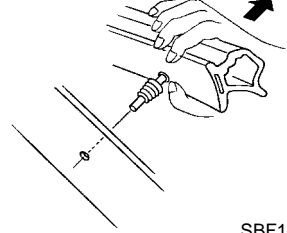
- Clips and fasteners in BT section correspond to the following numbers and symbols.
- Replace any clips and/or fasteners which are damaged during removal or installation.

Symbol No.	Shapes	Removal & Installation
C101 	 <p>SBF302H</p>	<p>Removal: Remove by bending up with flat-bladed screwdrivers or clip remover.</p>  <p>SBF367BA</p>
C103 	 <p>SBT095</p>	 <p>Removal: Remove with a clip remover.</p> <p>SBF423H</p>
C205 	 <p>MBT080A</p>	<p>Removal: Flat-bladed screwdriver</p>  <p>Clip Finisher</p> <p>SBF638CA</p>
C206 	 <p>MBF519B</p>	 <p>MBF520B</p>
CE103 	 <p>SBF104B</p>	<p>Removal:</p>  <p>SBF147B</p>

GI
MA
EM
LC
EC
FE
CL
MT
AT
AX
SU
BR
ST
RS
BT
HA
SC
EL
IDX

CLIP AND FASTENER

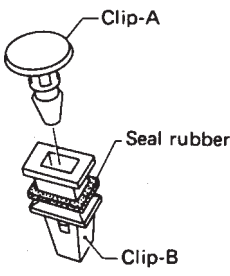
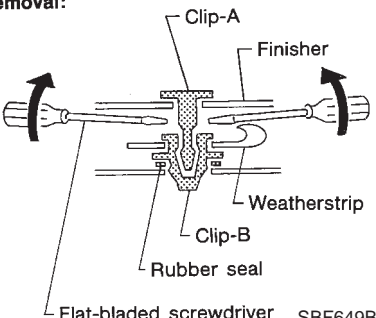
Description (Cont'd)

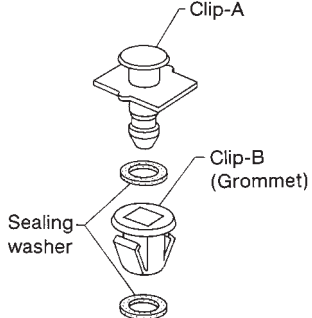
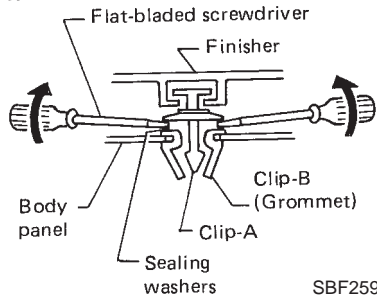
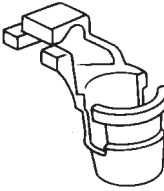
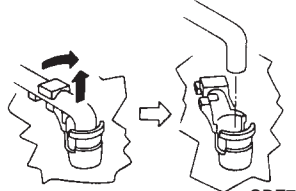
Symbol No.	Shapes	Removal & Installation
<p>CF110</p> 	 <p>Clip-A</p> <p>Seal rubber</p> <p>Clip-B</p> <p>SBF648B</p>	<p>Removal:</p>  <p>Clip-A</p> <p>Finisher</p> <p>Weatherstrip</p> <p>Clip-B</p> <p>Rubber seal</p> <p>Flat-bladed screwdriver</p> <p>SBF649B</p>
<p>CF118</p> 	 <p>Clip-A</p> <p>Clip-B (Grommet)</p> <p>Sealing washer</p> <p>SBF151D</p>	<p>Removal:</p>  <p>Flat-bladed screwdriver</p> <p>Finisher</p> <p>Body panel</p> <p>Clip-B (Grommet)</p> <p>Clip-A</p> <p>Sealing washers</p> <p>SBF259G</p>
<p>CR103</p>	 <p>SBF768B</p>	<p>Removal: Holder portion of clip must be spread out to remove rod.</p>  <p>SBF770B</p>

Removal and Installation

NFBT0004

- When removing or installing hood, place a cloth or other padding on hood. This prevents vehicle body from being scratched.
- Bumper fascia is made of plastic. Do not use excessive force and be sure to keep oil away from it.
- Hood adjustment: Adjust at hinge portion.
- Hood lock adjustment: After adjusting, check hood lock control operation. Apply a coat of grease to hood locks engaging mechanism.
- Hood opener: Do not attempt to bend cable forcibly. Doing so increases effort required to unlock hood.

WARNING:

- **Be careful not to scratch hood stay when installing hood. A scratched stay may cause gas leakage.**
- **The contents of the hood stay are under pressure. Do not take apart, puncture, apply heat or allow fire near it.**

FRONT BUMPER ASSEMBLY

NFBT0004S01

1. Remove clips securing engine undercover from front side. **A**
2. Remove clip and bolt securing left and right sides of front fender protectors. **B**
3. Remove screws securing left and right sides of front fender protectors. **C**
4. Remove clips securing left and right sides of front fender protectors in wheelhouse. **D**
5. Remove screws securing left and right front fenders to bumper fascia. **E**
6. Remove clips and protector securing bumper fascia. **F**
7. Extract bumper fascia assembly, then disconnect fog lamp and side marker lamp harness connectors.
8. Remove energy absorber.
9. Remove bolts, hook and pawl securing headlamp assembly, then disconnect harness connectors. **G**
10. Remove bolt and nuts securing bumper upper retainer. **H**
11. Remove bolts and nuts securing bumper bracket. **J**
12. Remove nuts securing bumper reinforcement to left and right bumper stays. **K**
13. Extract bumper reinforcement.
14. Remove bolts and nut securing bumper stays, then remove the bumper stays. **L**

Fog lamp assembly

15. Remove bolt securing fog lamp assembly. **M**
16. Extract fog lamp assembly. **M**

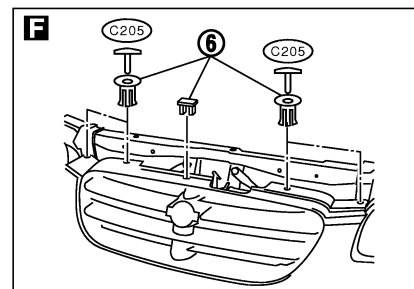
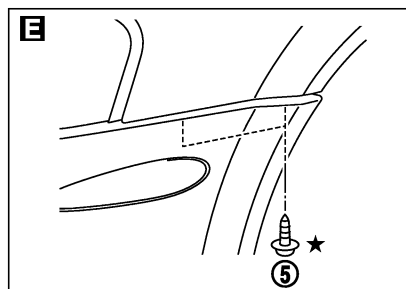
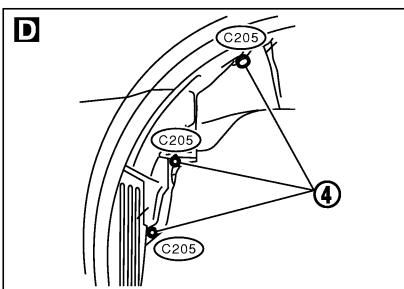
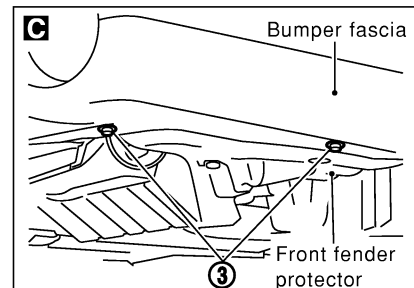
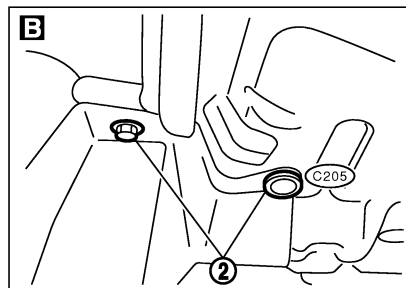
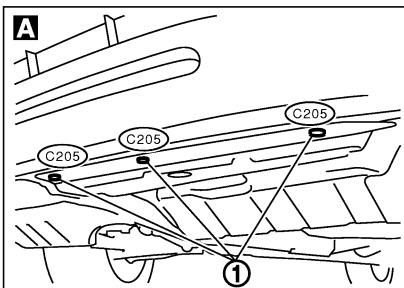

★ : Bumper assembly mounting screws

SBT765

GI
MA
EM
LC
EC
FE
CL
MT
AT
AX
SU
BR
ST
RS
BT
HA
SC
EL
IDX

BODY FRONT END

Removal and Installation (Cont'd)

SEC. 260•261•262•620•630•650

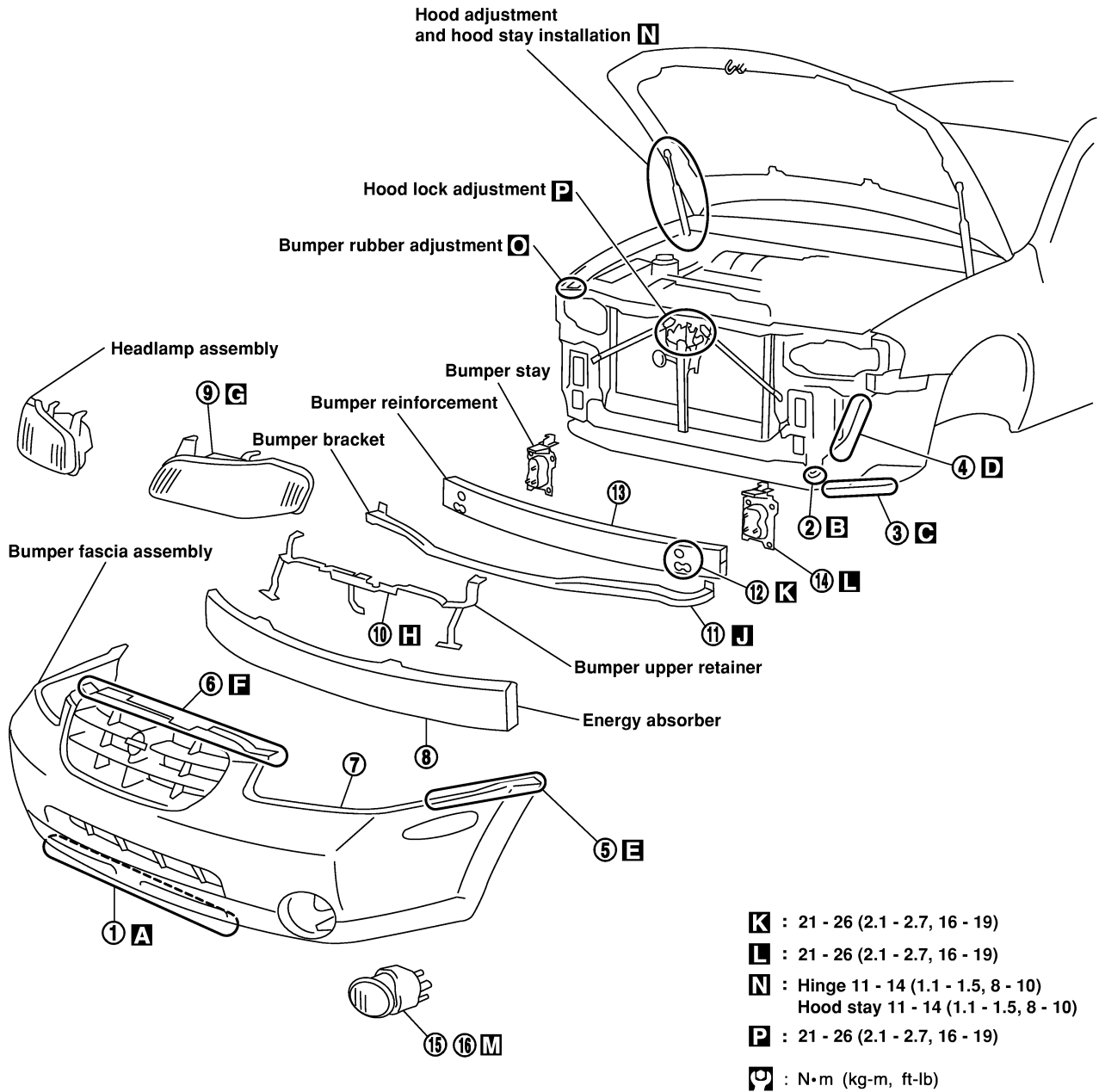

SBT766

BODY FRONT END

Removal and Installation (Cont'd)

<p>G</p>	<p>I</p> <p>Pawl Hook</p>	<p>J</p>
<p>H</p>	<p>K</p>	<p>L</p> <p>21 - 26 (2.1 - 2.7, 16 - 19)</p>
<p>M</p> <p>21 - 26 (2.1 - 2.7, 16 - 19)</p>	<p>N</p> <p>Pawl 16</p>	<p>O</p> <p>17</p>
<p>P</p> <p>Hood stay 11 - 14 (1.1 - 1.5, 8 - 10)</p>	<p>Q</p> <p>11 - 14 (1.1 - 1.5, 8 - 10)</p>	<p>R</p> <p>11 - 14 (1.1 - 1.5, 8 - 10)</p>
<p>S</p> <p>11 - 14 (1.1 - 1.5, 8 - 10)</p>	<p>T</p> <p>11 - 14 (1.1 - 1.5, 8 - 10)</p>	<p>U</p> <p>11 - 14 (1.1 - 1.5, 8 - 10)</p>

GI
MA
EM
LC
EC
FE
CL
MT
AT
AX
SU
BR
ST
RS
BT
HA
SC
EL
IDX

★ : Bumper assembly mounting bolts and nuts

: N·m (kg·m, ft·lb)

SBT767

BODY REAR END AND OPENER

Removal and Installation

Removal and Installation

NFBT0005

- When removing or installing trunk lid, place a cloth or other padding on trunk lid. This prevents vehicle body from being scratched.
- Bumper fascia is made of plastic. Do not use excessive force and be sure to keep oil away from it.
- Trunk lid adjustment: Adjust at hinge-trunk lid portion for proper trunk lid fit.
- Trunk lid lock system adjustment: Adjust striker so that it is in the center of the lock. After adjustment, check trunk lid lock operation.
- After installation, make sure that trunk lid and fuel filler lid open smoothly.

★ For Wiring Diagram, refer to EL-184, "TRUNK LID AND FUEL FILLER LID OPENER".

REAR BUMPER ASSEMBLY

NFBT0005S01

1. Remove screws securing left and right rear fenders to bumper fascia. **A**
2. Remove screws securing left and right rear fenders to bumper fascia lower side. **B**
3. Remove clips securing bumper fascia. **C**
4. Remove trunk room trim. Refer to "TRUNK ROOM TRIM" for details, BT-39.
5. Working from inside trunk, remove jack then remove nuts securing jack bracket. **D**
6. Working from inside trunk, remove bolts securing left and right rear fenders to bumper fascia. **E**
7. Working from inside trunk, remove nuts securing rear panel to bumper fascia. **F**
8. Extract bumper fascia assembly after removing the clamps securing it. **G**
9. Remove energy absorber.
10. Remove nuts securing bumper reinforcement to left and right bumper stays. **H**
11. Extract bumper reinforcement.
12. Remove nuts securing bumper stays, then remove the bumper stays. **J**

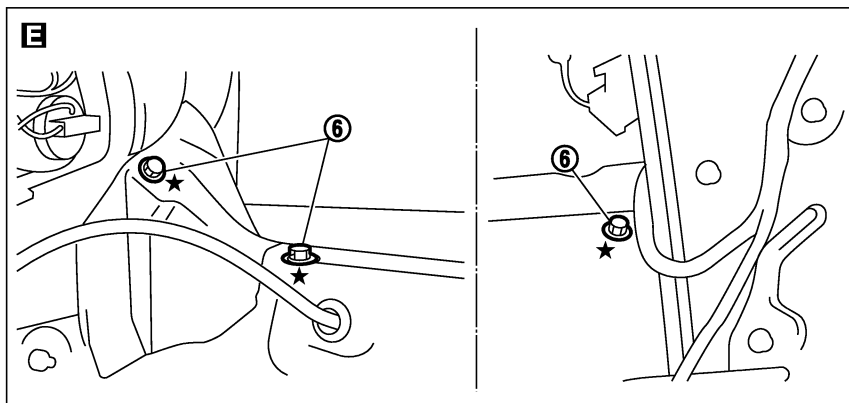
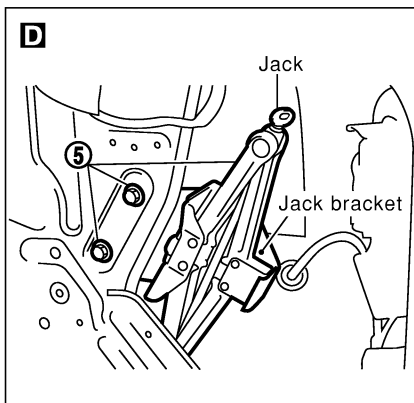
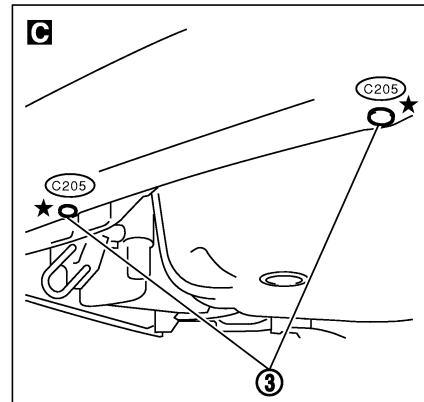
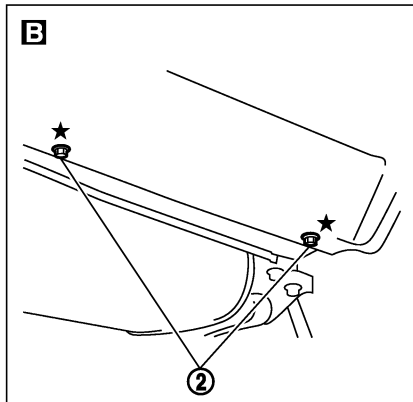
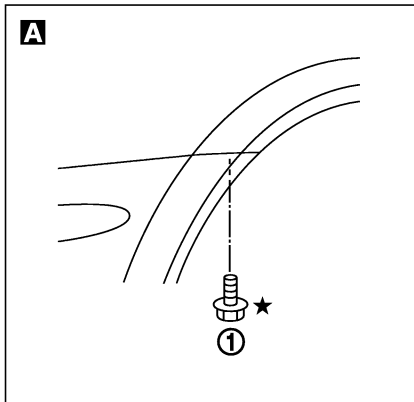

★ : Bumper assembly mounting clips & bolts

SBT768

BODY REAR END AND OPENER

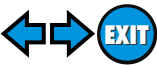

Removal and Installation (Cont'd)

SEC. 843-850

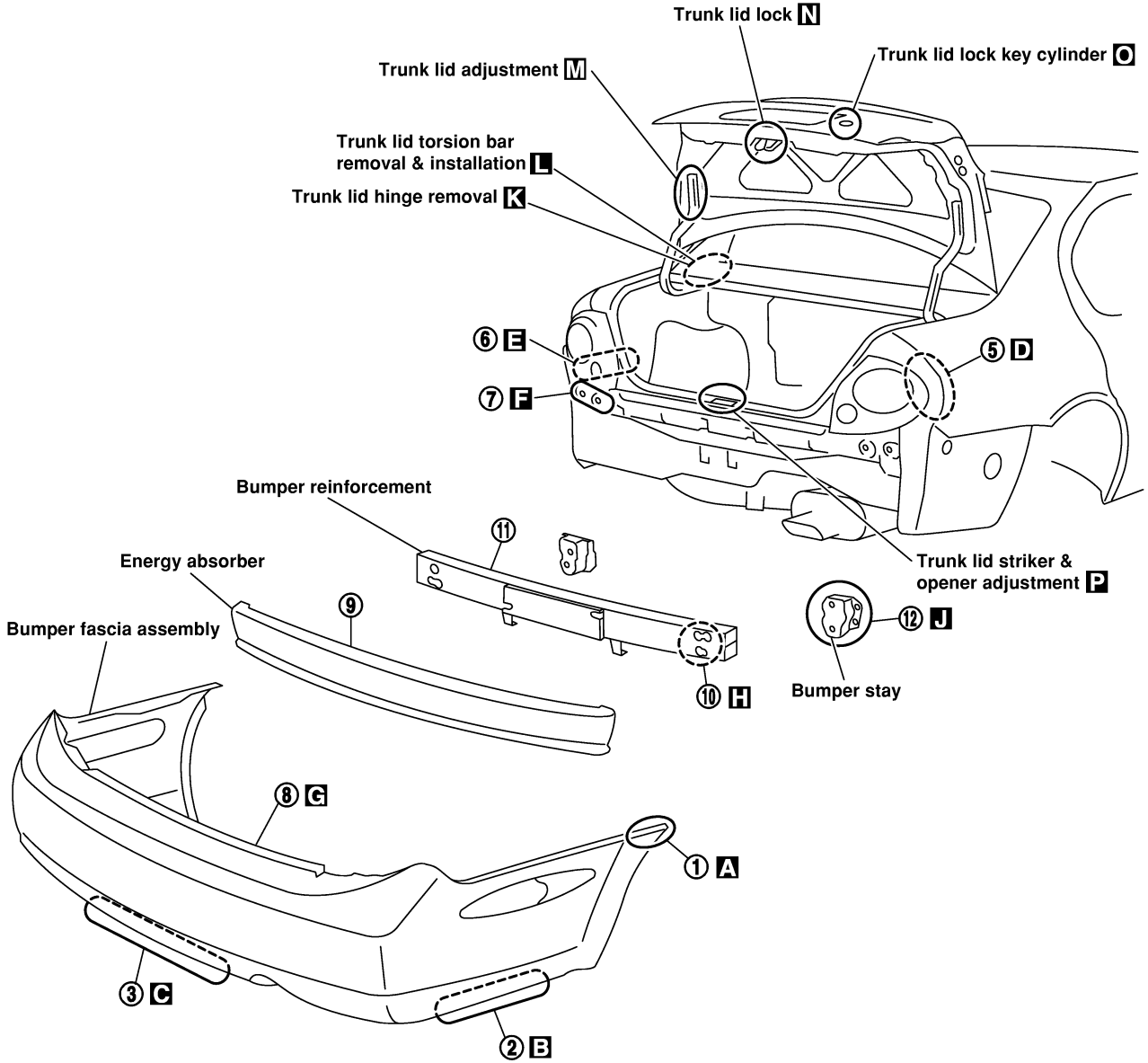

- J** : 21 - 26 N·m (2.1 - 2.7 kg-m, 16 - 19 ft-lb)
- H** : 21 - 26 N·m (2.1 - 2.7 kg-m, 16 - 19 ft-lb)
- M** : 5.1 - 6.4 N·m (0.52 - 0.66 kg-m, 46 - 57 in-lb)

GI
MA
EM
LC
EC
FE
CL
MT
AT
AX
SU
BR
ST
RS
BT
HA
SC
EL
IDX

SBT769

BODY REAR END AND OPENER

Removal and Installation (Cont'd)

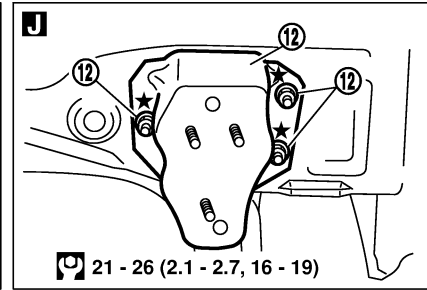
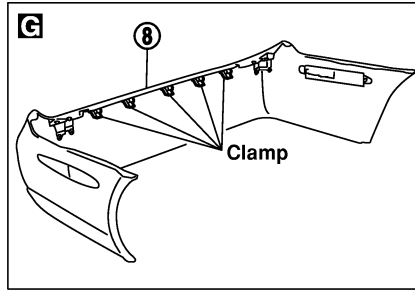
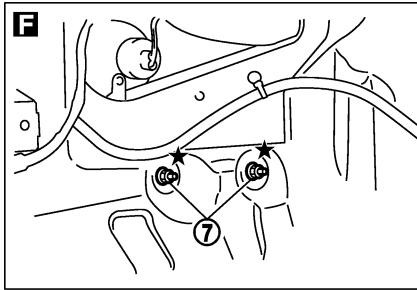

21 - 26 (2.1 - 2.7, 16 - 19)

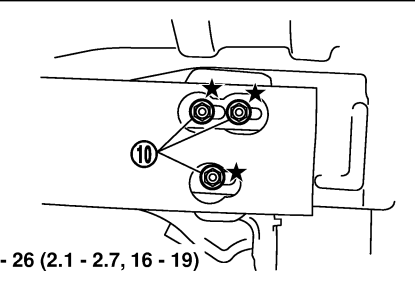
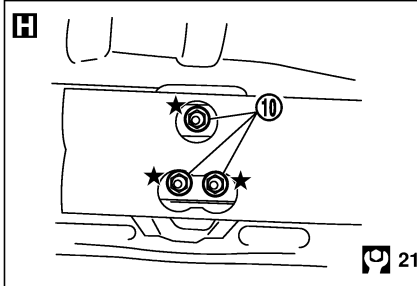

21 - 26 (2.1 - 2.7, 16 - 19)

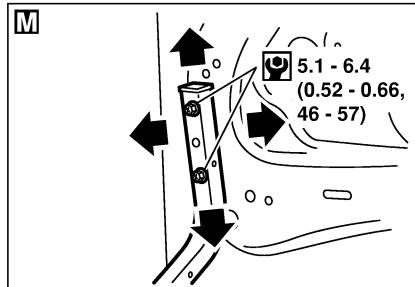
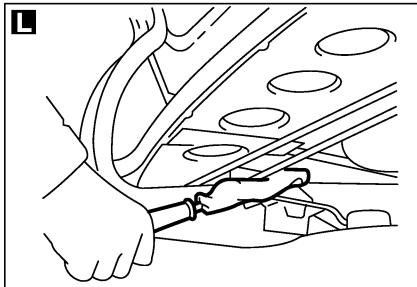
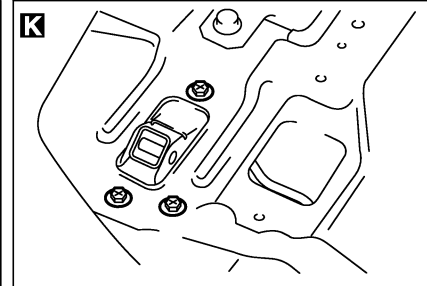

5.1 - 6.4
(0.52 - 0.66,
46 - 57)

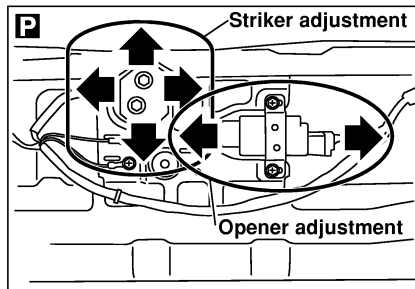
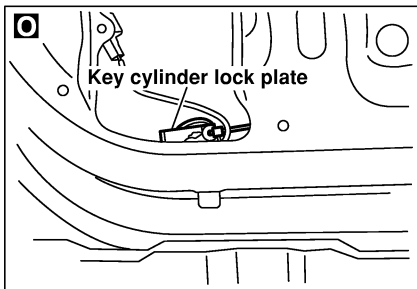
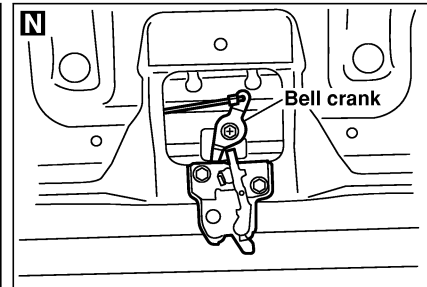

★ : Bumper assembly mounting nuts

: N•m (kg-m, ft-lb)

: N•m (kg-m, in-lb)

Adjustment

NFBT0006

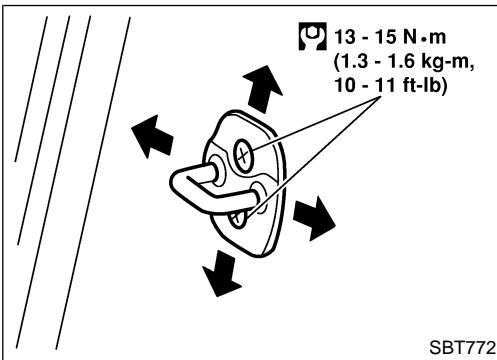
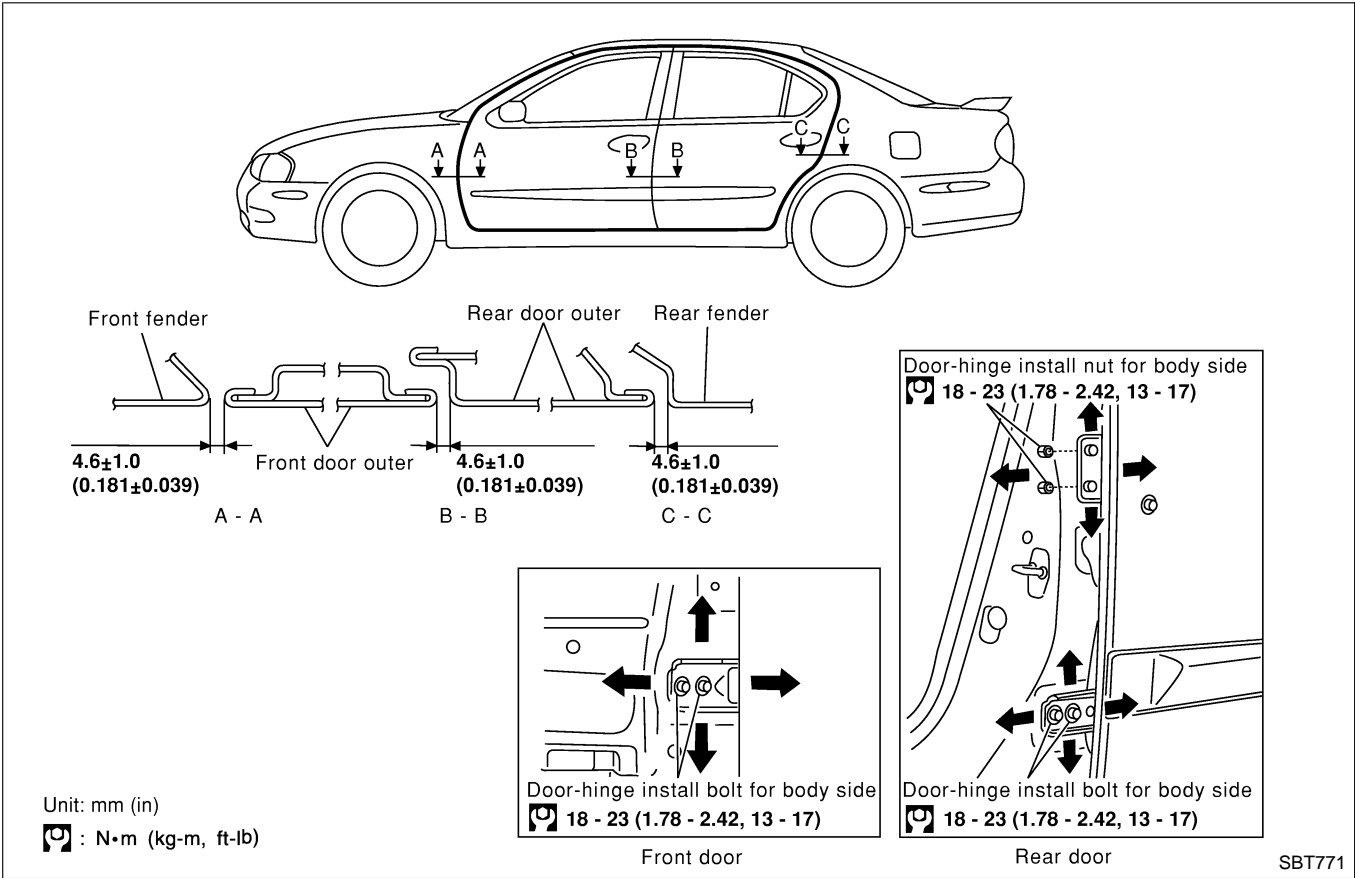

STRIKER ADJUSTMENT

NFBT0006S01

Adjust striker so that it is parallel with advancing direction of door lock.

GI
MA
EM
LC
EC
FE
CL
MT
AT
AX
SU
BR
ST
RS
BT
HA
SC
EL
IDX

DOOR

Front Door Glass

=NFBT0007

- Make sure that door glass is positioned in glass run groove.
- Make sure that there is no abnormality when door glass is raised or lowered.

FRONT DOOR GLASS AND REGULATOR

NFBT0007S01

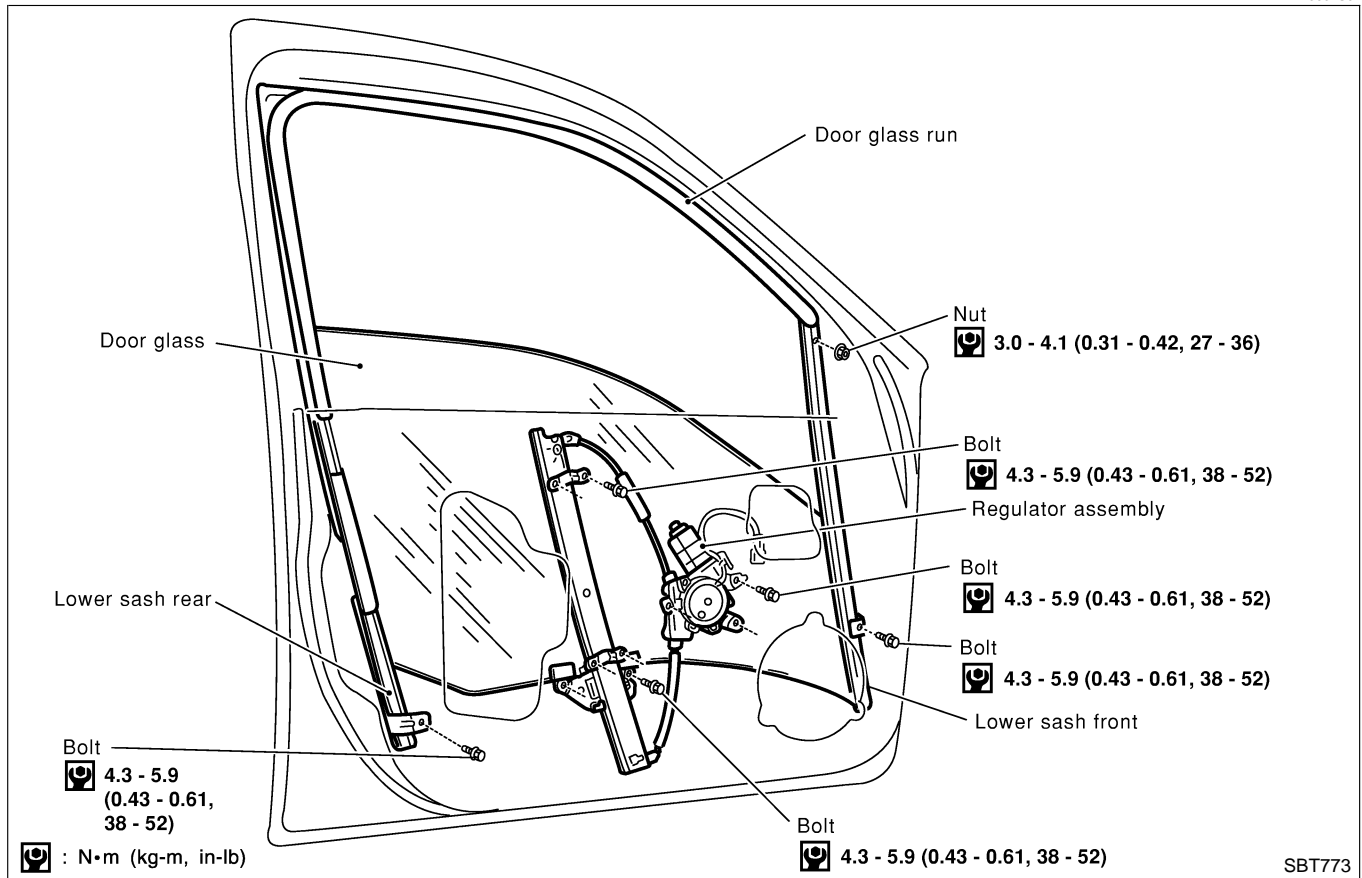

- For removal of front door trim, refer to "DOOR TRIM", BT-35.
- For removal of door mirror, refer to "DOOR MIRROR", BT-61.
- For removal of door outside molding, refer to "EXTERIOR", BT-40.
- Remove sealing screen.

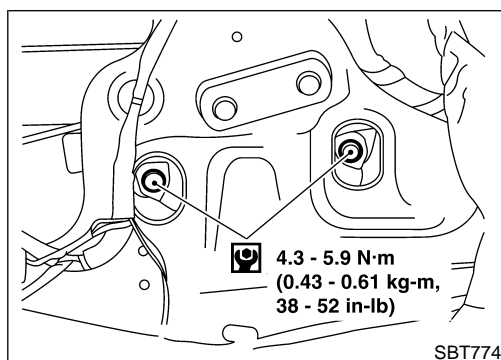

1. Using power window main switch, raise or lower door glass until carrier plate securing bolts are visible.
2. Remove bolts securing carrier plate.

DOOR

Front Door Glass (Cont'd)

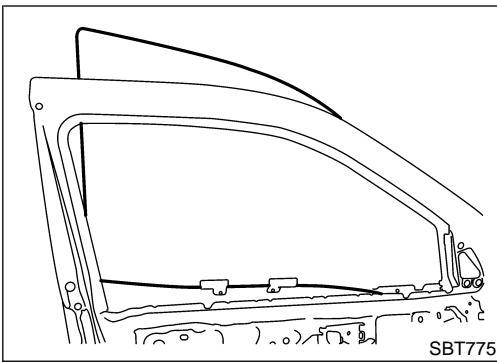

3. Hold door glass with both hands. While raising rear end of door glass, remove door glass from sash and away from outside the door.

GI

MA

EM

LC

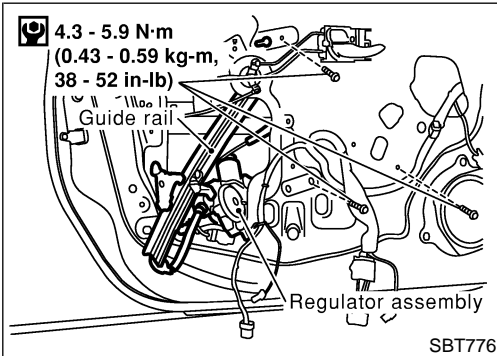

4. Disconnect regulator assembly connector.
5. Remove bolts securing regulator assembly and guide rail, then remove regulator assembly and guide rail.

EC

FE

CL

MT

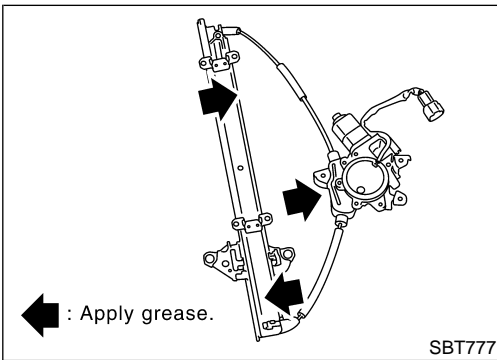

Inspection

Check regulator assembly for the following parts. Replace faulty parts with new ones.

NFBT0007S0101

- Wire for wear
- Regulator for deformation
- Sliding parts for lubrication

AT

AX

SU

BR

Front Door Limit Switch Reset (Driver side only)

NFBT0008

RESET CONDITIONS

After each of the following operations are performed, reset the limit switch (with built-in motor).

NFBT0008S01

- Regulator removal and installation
- Removal of motor from regulator
- Operation of regulator as a single unit
- Door glass removal and installation
- Glass run removal and installation

ST

RS

BT

HA

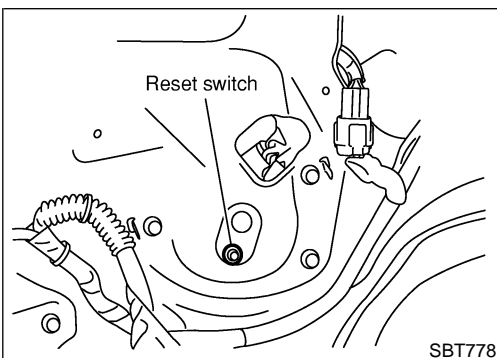

RESET PROCEDURES

After installing parts, proceed as follows:

NFBT0008S02

1. Close the door window completely.
2. Press the reset switch and open the door window completely.
3. Release the reset switch. After making sure the reset switch has returned to the original position, close the door window completely.
4. The limit switch is now reset.

SC

EL

IDX

CAUTION:

Be sure to manually open or close the door window. (Do not use the automatic open-close procedures.)

DOOR

Rear Door Glass

Rear Door Glass

NFBT0009

- Make sure that door glass is positioned in glass run groove.
- Make sure that there is no abnormality when door glass is raised or lowered.

REAR DOOR GLASS AND REGULATOR

NFBT0009S01

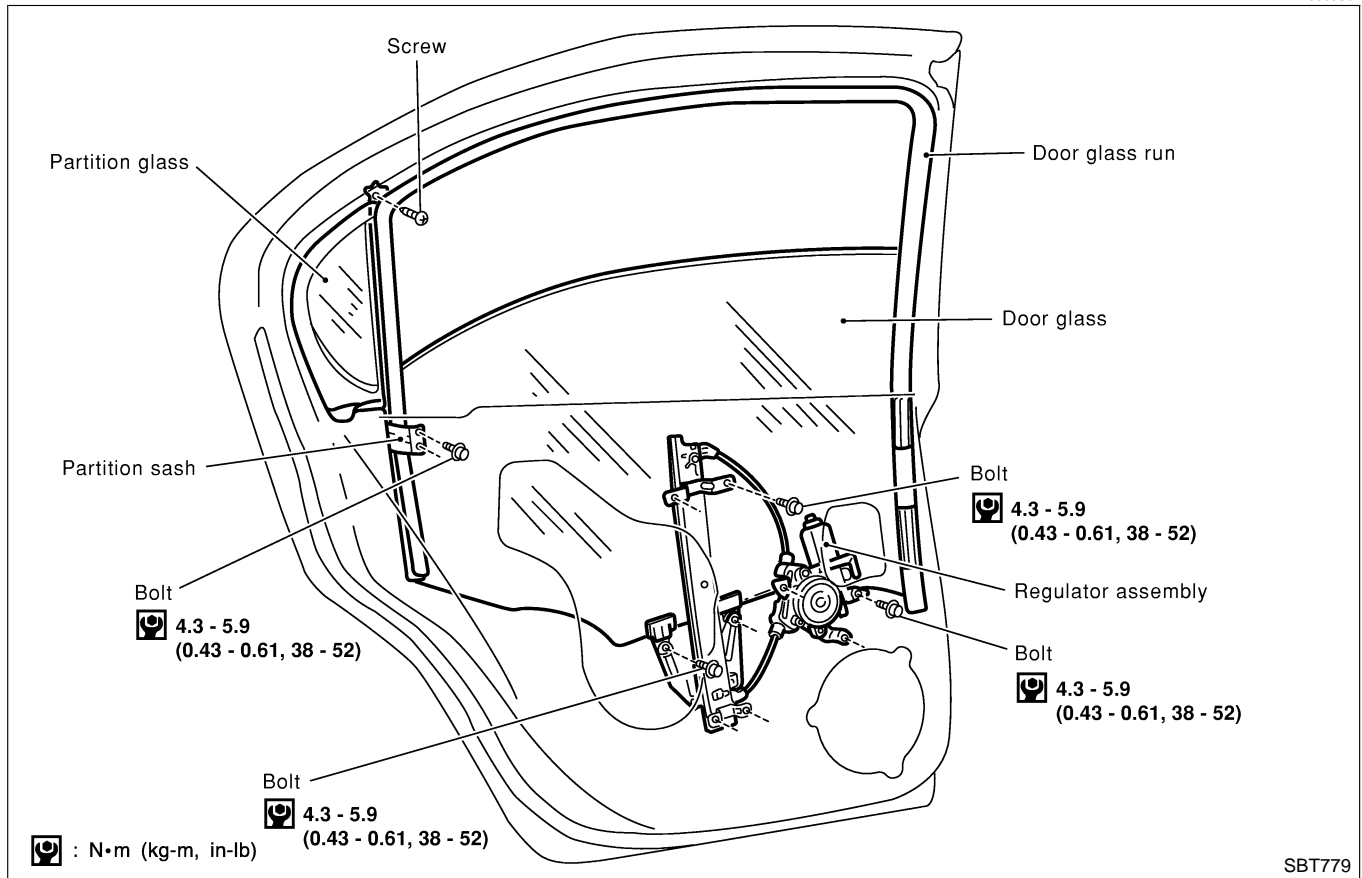

- For removal of rear door trim, refer to "DOOR TRIM", BT-35.
- For removal of door outside molding, refer to "EXTERIOR", BT-40.
- Remove sealing screen.

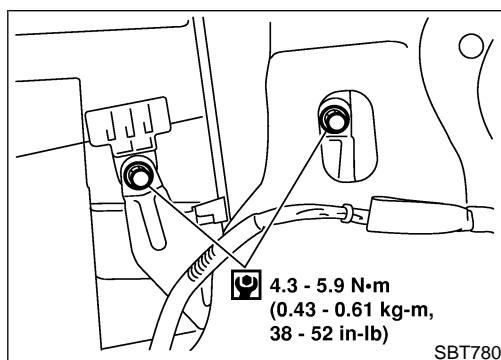

1. Using power window main switch, raise or lower door glass until carrier plate securing bolts are visible.
2. Remove bolts securing carrier plate.

DOOR

Rear Door Glass (Cont'd)

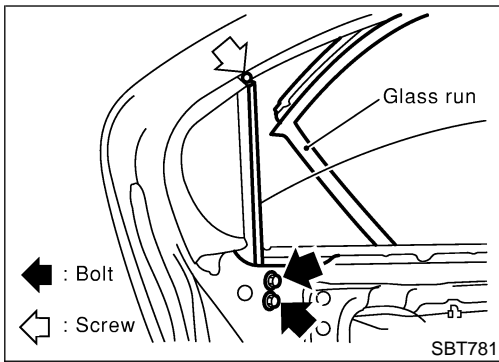

3. Remove partition sash at glass run.
4. Remove bolts and screw securing partition sash.

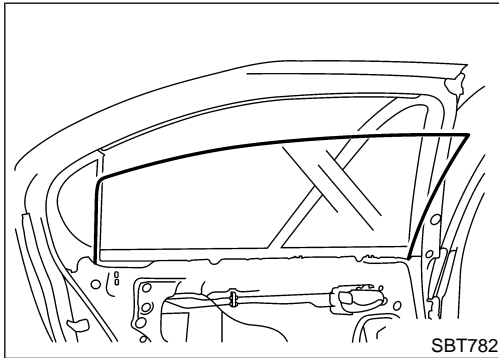

5. Hold door glass with both hands. While raising rear end of door glass, remove door glass from sash and away from inside the door.

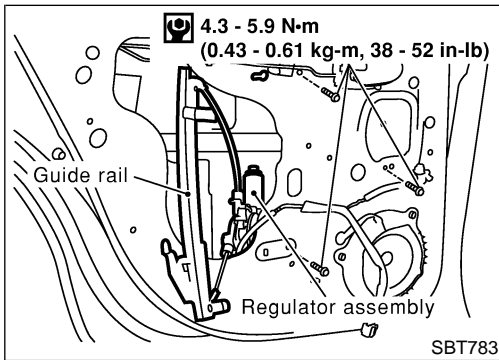

6. Disconnect regulator assembly connector.
7. Remove bolts securing regulator assembly and guide rail, then remove regulator assembly and guide rail.

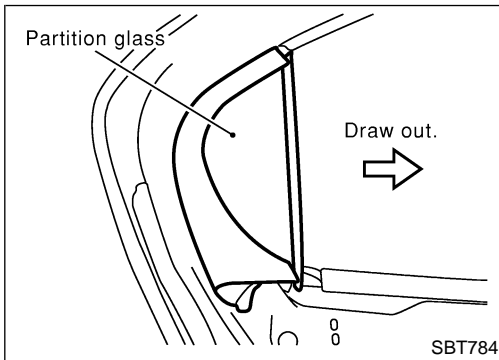

8. Remove partition glass.

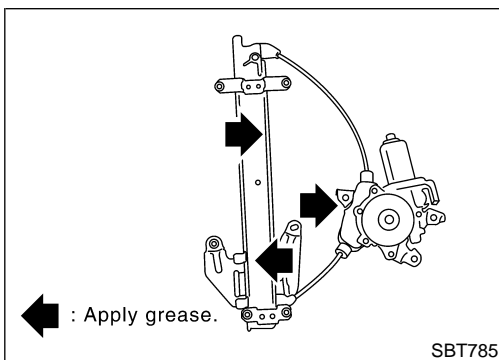

Inspection

Check regulator assembly for the following parts. Replace faulty parts with new ones. NFBT0009S0101

- Wire for wear
- Regulator for deformation
- Sliding parts for lubrication

GI

MA

EM

LC

EC

FE

CL

MT

AT

AX

SU

BR

ST

RS

BT

HA

SC

EL

IDX

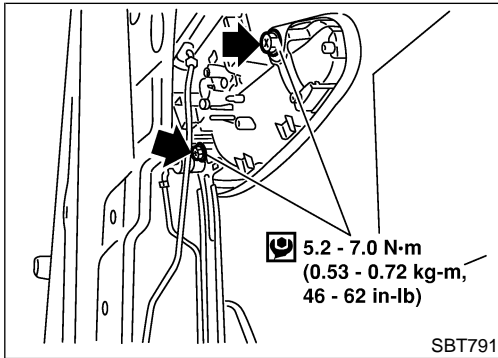
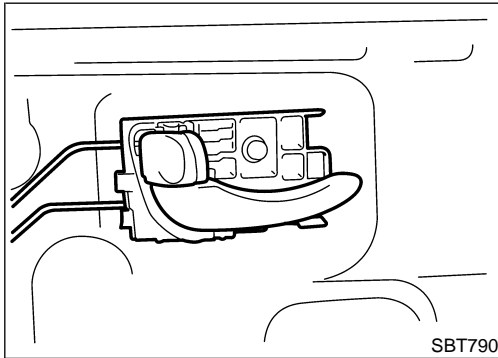
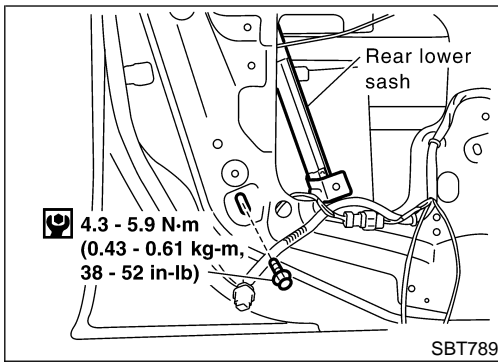

REMOVAL

- For removal of front door trim, refer to “DOOR TRIM”, BT-35.
 - Remove sealing screen.
 - For removal of front door glass, refer to “Front Door Glass”, BT-20.
1. Remove lower rear sash (unitized with glass run) securing bolts. Remove lower rear sash from door panel and away from door lock.
 2. Remove inside handle escutcheon A.
 3. Remove screw securing inside handle.
 4. Detach bell crank at lock knob joining area.
 5. Detach inside handle rod on the door lock assembly side.
 6. Slide inside handle backward and remove inside handle.
 7. Remove rod from inside handle.
 8. Detach key lock rod and outside handle rod at joining area (on the outside handle side).
 9. Disconnect door lock actuator connector.
 10. Remove screws securing door lock assembly, then remove door lock assembly.
 11. Remove bolts securing outside handle, then remove outside handle assembly.

GI

MA

EM

LC

EC

FE

CL

MT

AT

AX

SU

BR

ST

RS

BT

HA

SC

EL

IDX

Rear Door Lock

=NFBT0011

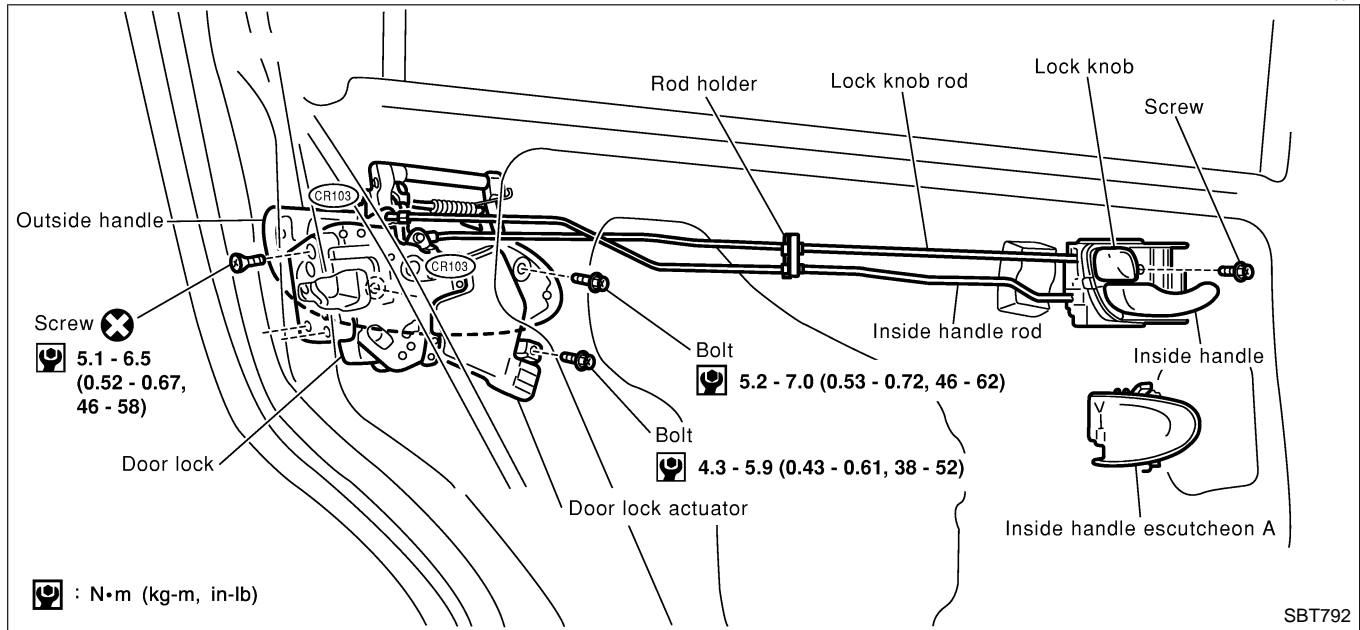

- For removal of rear door trim, refer to “DOOR TRIM”, BT-35.
- Remove sealing screen.

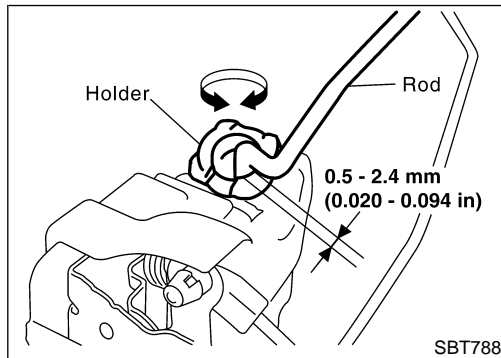

OUTSIDE HANDLE ROD ADJUSTMENT

NFBT0011S01

Rotate rod holder so that rod-to-holder clearance is adjusted as shown in the figure at left.

CAUTION:

Make sure that rod-to-holder clearance is not “0” mm (0 in), and that rod is not held pressed.

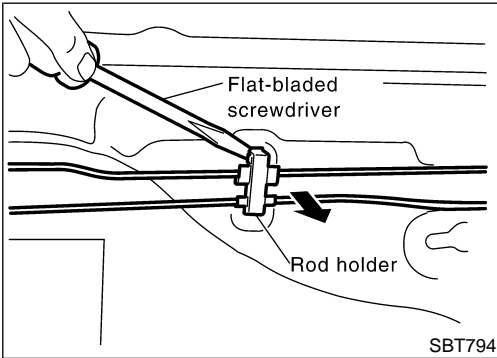
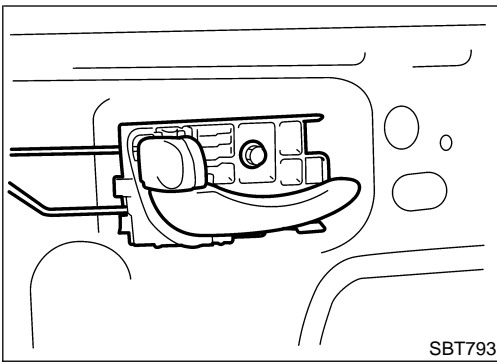

REMOVAL

- For removal of rear door trim, refer to “DOOR TRIM”, ^{=NFBT0011S02} BT-35.
 - Remove sealing screen.
 - For removal of rear door glass, refer to “Rear Door Glass”, BT-22.
1. Remove inside handle escutcheon A.
 2. Remove screw securing inside handle.
 3. Detach inside handle rod on the door lock assembly side.
 4. Detach lock knob rod (on the door lock assembly side).
 5. Using a flat-bladed screwdriver, expand rod holder. Remove rod from rod holder.
 6. Slide inside handle backward and remove inside handle.
 7. Remove rod from inside handle.
 8. Disconnect door lock actuator connector.
 9. Remove screws securing door lock assembly, then remove door lock assembly.
 10. Remove bolts securing outside handle, then remove outside handle.

GI

MA

EM

LC

EC

FE

CL

MT

AT

AX

SU

BR

ST

RS

BT

HA

SC

EL

IDX

Removal and Installation

NFBT0012

CAUTION:

- Disconnect ground terminal from battery in advance.
- Disconnect air bag system line in advance.
- Never tamper with or force air bag lid open, as this may adversely affect air bag performance.
- Be careful not to scratch pad and other parts.

INSTRUMENT PANEL ASSEMBLY

Removal and Installation (Cont'd)

Instrument panel assembly	Combination meter	Audio & A/C control	Console box
Remove air bag module (driver) and steering wheel. Refer to (*1), "Driver Air Bag Module and Spiral Cable" for details.		a	
Remove dash side lower finishers. Refer to "SIDE AND FLOOR TRIM" for details. (*2)			
① Steering column cover and combination switch • Remove screws and disconnect harness connectors.			
② Instrument lower panel on driver side • Remove bolts.			A
③ Instrument lower reinforcement • Remove bolts.			
④ Cluster lid A • Remove screws then disconnect harness connectors.	B	Remove steering column mounting nuts. Refer to "Steering Wheel and Steering Column" for details. (*3)	
⑤ Combination meter • Remove screws then disconnect harness connectors.		a	
⑥ Center ventilator assembly • Remove clips.			C
⑦ Ashtray			
⑧ Console M/T or A/T finisher • Disconnect harness connectors.			D
⑨ Audio & A/C control unit assembly • Remove screws then disconnect harness connectors.			
⑩ Glove box assembly • Remove screws. • Then disconnect passenger air bag module connector and remove bracket.	E		
⑪ Passenger air bag module • Refer to "Front Passenger Air Bag Module" for details. (*4)			
⑫ Instrument stay cover • Remove clips.			F
⑬ Console box assembly • Remove screws then disconnect harness connectors.			
⑭ Clock finisher assembly • Disconnect harness connector.	G		
⑮ Defroster grille • Disconnect connector.	H		
⑯ Front pillar garnish • Refer to "SIDE AND FLOOR TRIM" for details. (*2)			
⑰ Instrument panel and pad assembly • Remove bolts, nuts and screw.	J		

GI
MA
EM
LC
EC
FE
CL
MT
AT
AX
SU
BR
ST
RS
BT
HA
SC
EL
IDX

SBT795

*1 RS-20
*2 BT-32

*3 ST-10

*4 RS-22

INSTRUMENT PANEL ASSEMBLY

Removal and Installation (Cont'd)

SEC. 248•280•487•680•685•769•969

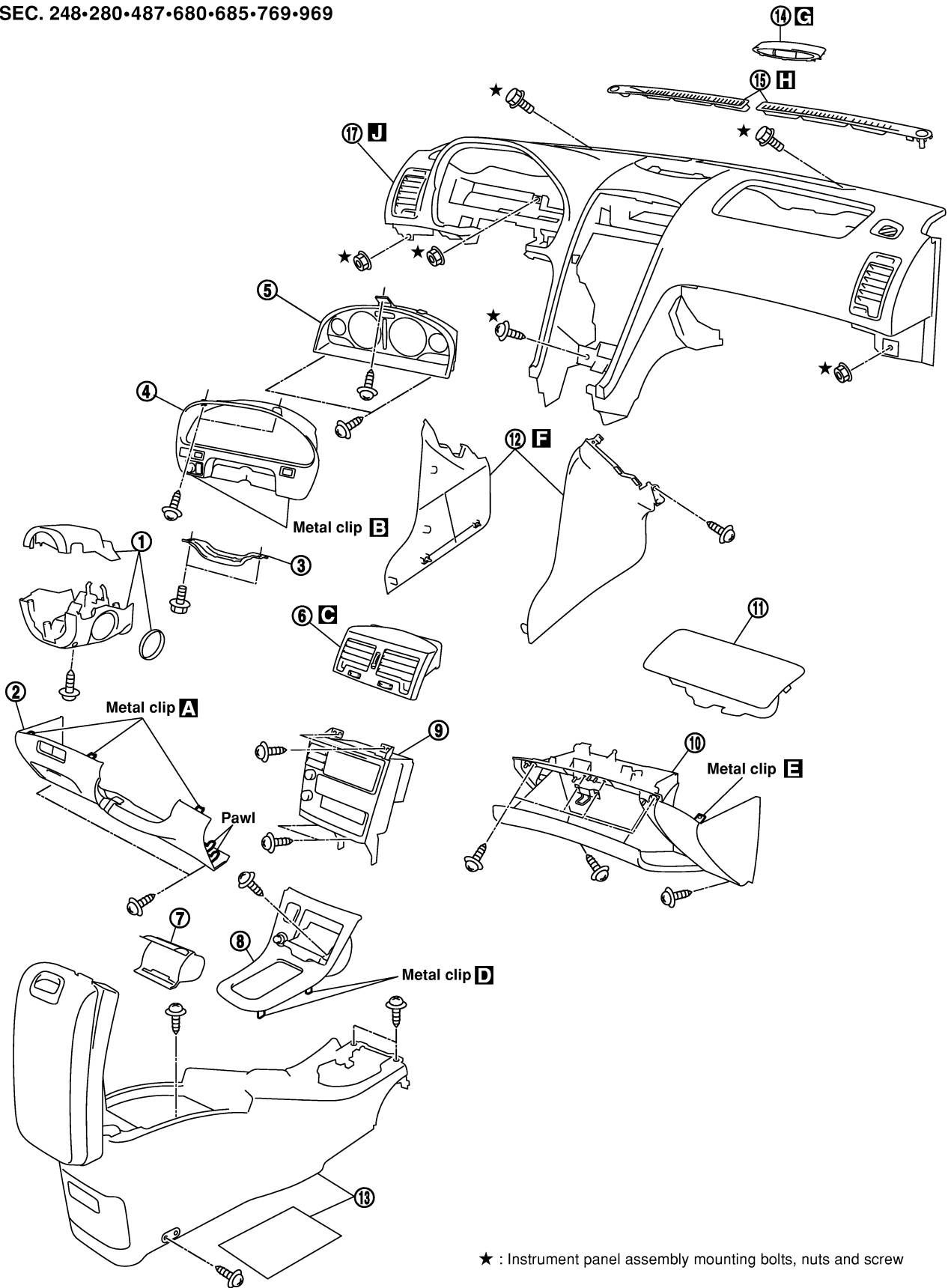

SBT796

INSTRUMENT PANEL ASSEMBLY

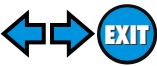

Removal and Installation (Cont'd)

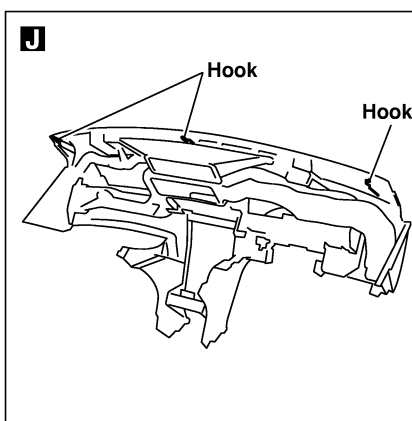
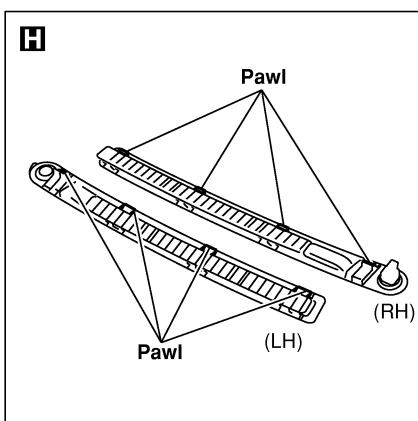
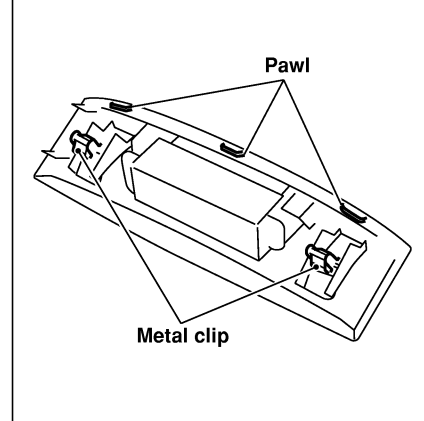
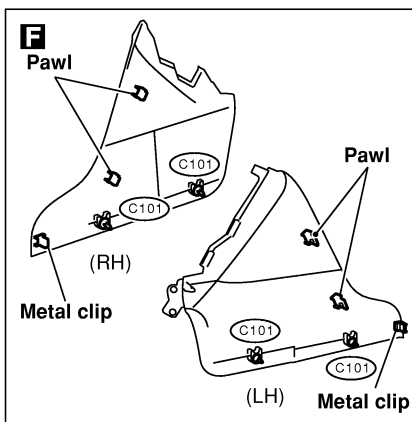
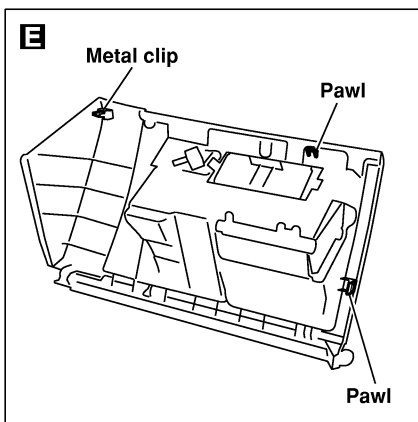
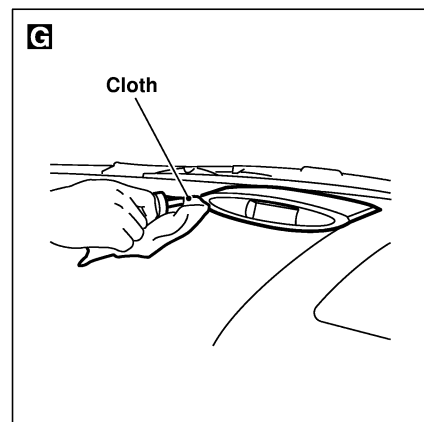
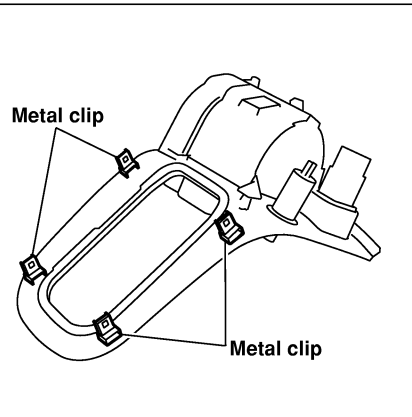
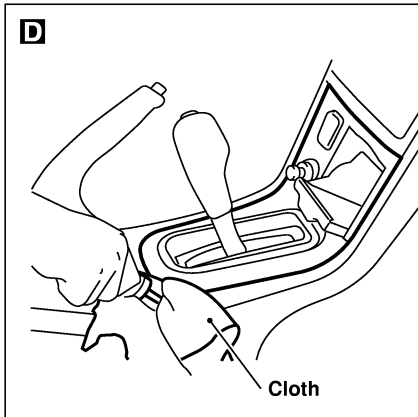
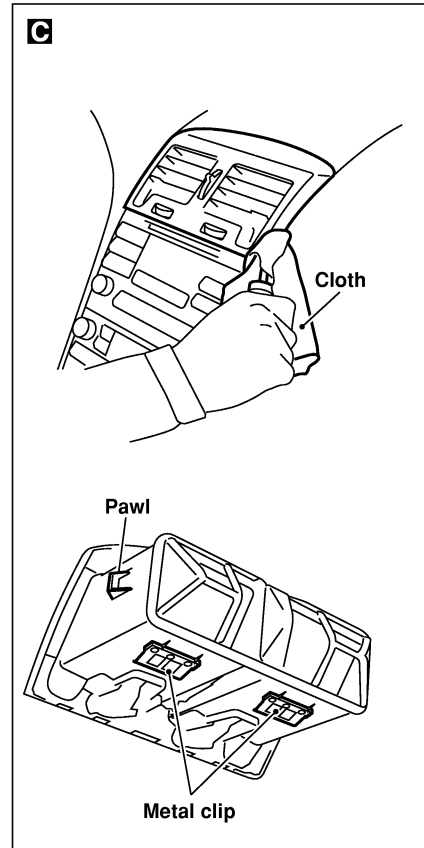
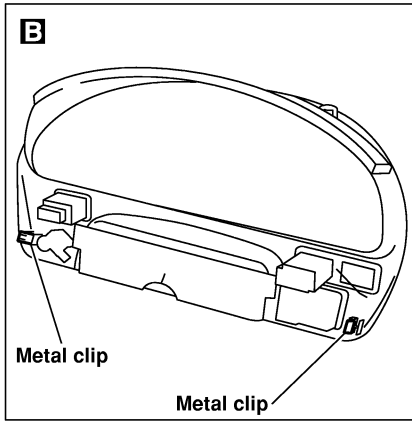
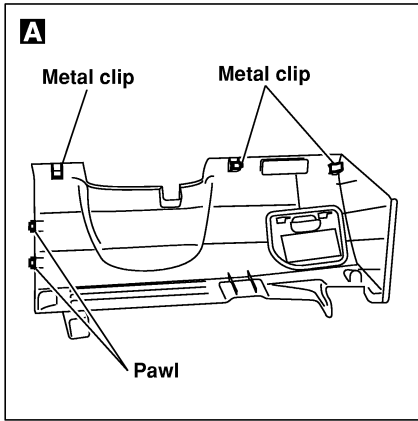

GI
MA
EM
LC
EC
FE
CL
MT
AT
AX
SU
BR
ST
RS
BT
HA
SC
EL
IDX

SBT797

SIDE AND FLOOR TRIM

Removal and Installation

Removal and Installation

NFBT0013

CAUTION:

- Wrap the tip of flat-bladed screwdriver with a cloth when removing metal clips from garnishes.
 - When removing or installing body side welts, do not allow butyl seal to come in contact with pillar garnish.
1. Remove front and rear seats. Refer to "FRONT SEAT" and "REAR SEAT" for details, BT-46 and BT-50.
 2. Remove front and rear seat belts. Refer to RS-5 and RS-7, "Front Seat Belt" and "Rear Seat Belt" for details.
 3. Remove front and rear outer kicking plates. **B D**
 4. Remove front and rear inner kicking plates. **B D**
 5. Remove dash side lower finisher. **E**
 6. Remove front and rear body side welts.
 7. Remove front pillar garnishes. **F**
 8. Remove center pillar lower garnishes. **G**
 9. Remove center pillar upper garnishes. **G**
 10. Remove rear pillar garnishes. **J**
 11. Remove high-mounted stop lamp. (Model without rear air spoiler)
 12. Remove seatback center finisher.
 13. Remove seatback side finishers.
 14. Remove rear parcel shelf finisher. **K L M N**
 15. Remove instrument lower covers.
 16. Remove accelerator pedal stopper.
 17. Remove carpet hook.
 18. Remove floor carpet.

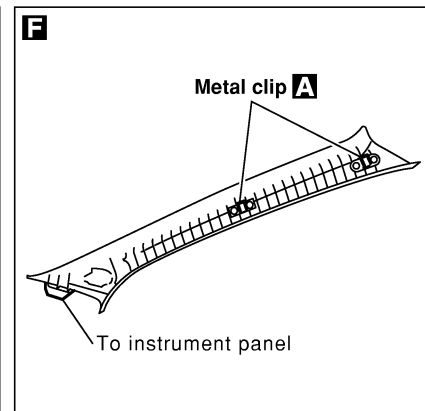
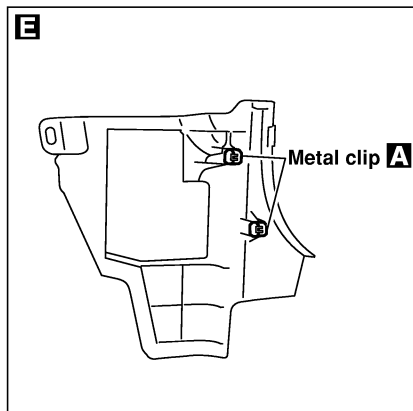
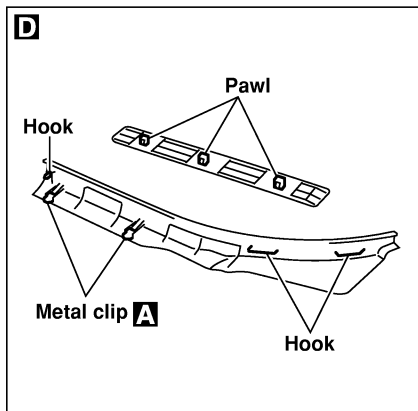
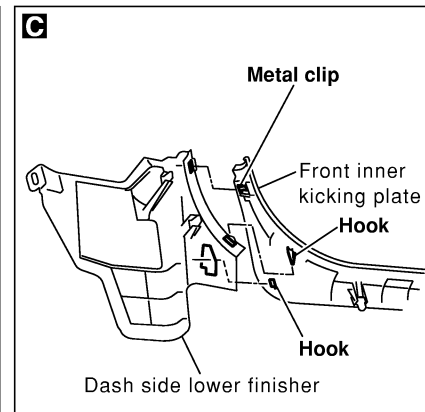
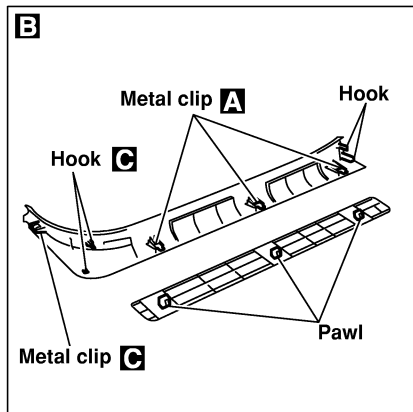
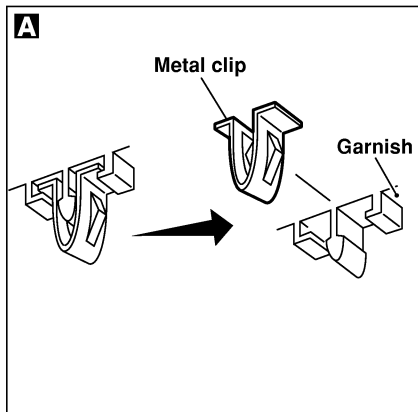

SBT837

SIDE AND FLOOR TRIM

Removal and Installation (Cont'd)

SEC. 678-749-769-799

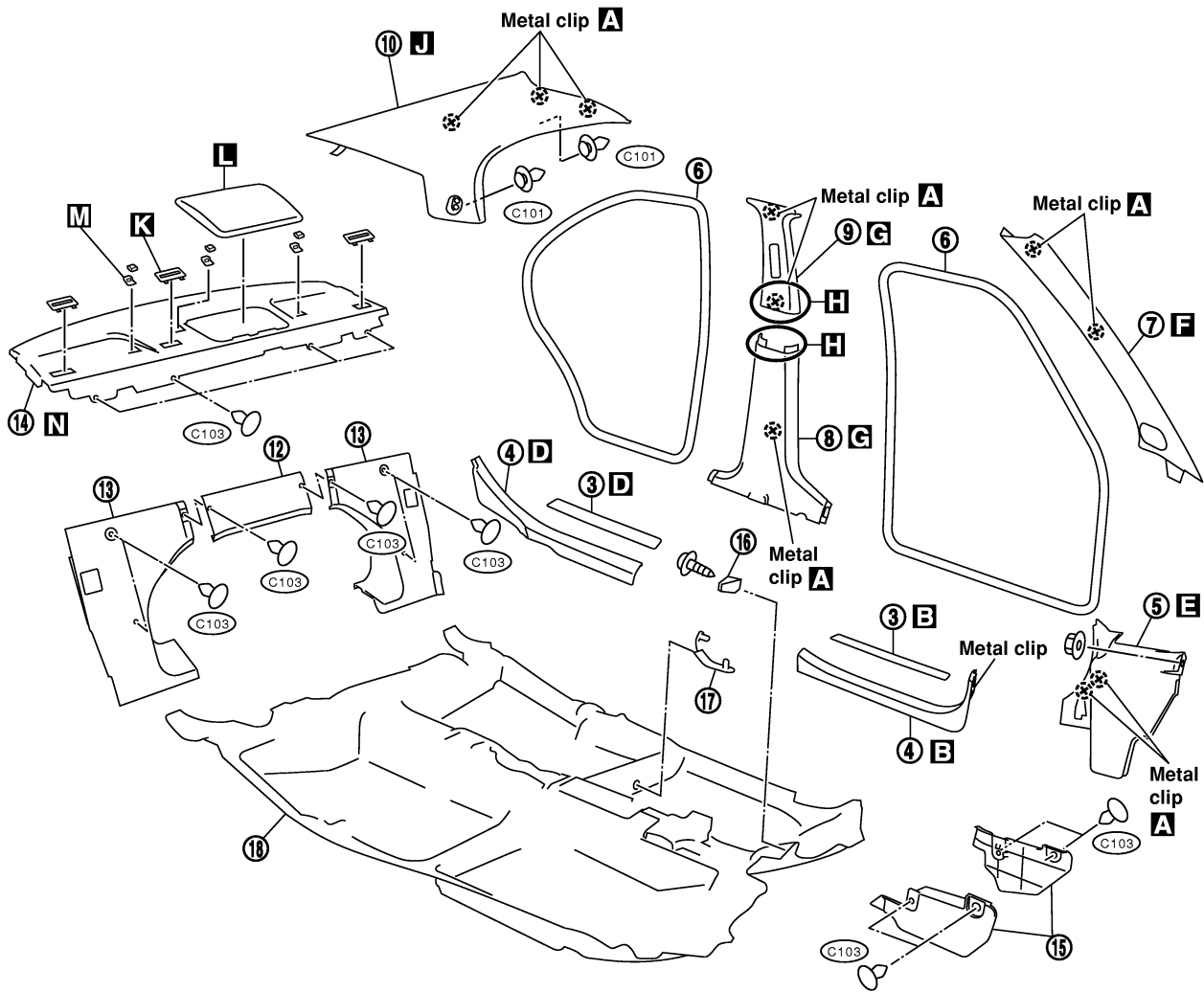

Remove high-mounted stop lamp. (Models without rear air spoiler)

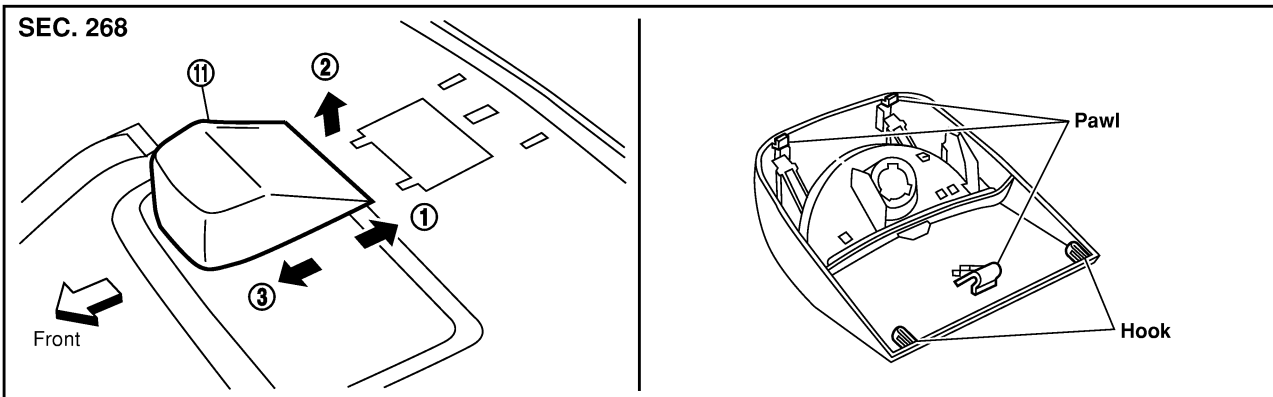

- GI
- MA
- EM
- LC
- EC
- FE
- CL
- MT
- AT
- AX
- SU
- BR
- ST
- RS
- BT**
- HA
- SC
- EL
- IDX

SBT798

SIDE AND FLOOR TRIM

Removal and Installation (Cont'd)

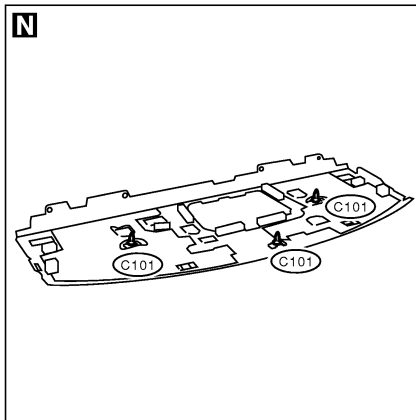
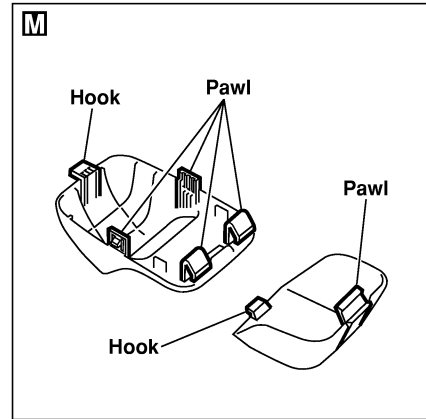
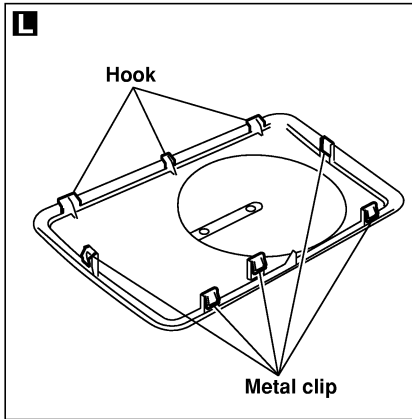
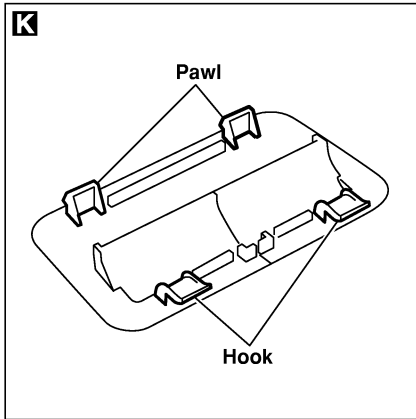
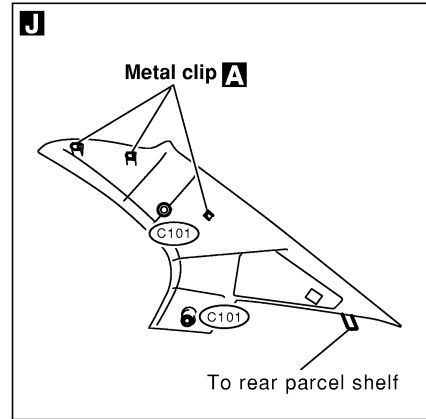
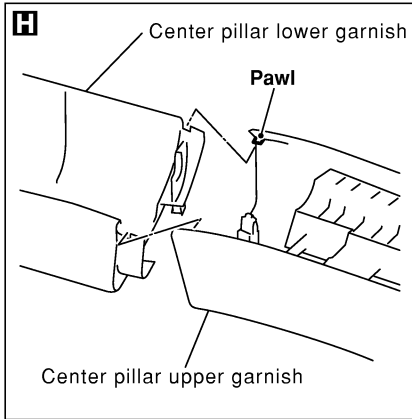
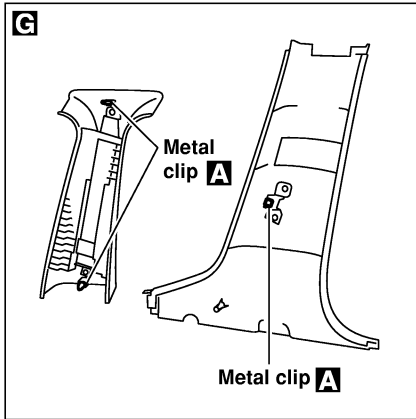

Removal and Installation

NFBT0014

Front door finisher

1. Remove inside handle escutcheon. **A**
2. Remove screw securing pull handle, and then remove pull handle.
3. Remove power window switch finisher, then disconnect the connectors. **B**
4. Remove mask securing front door finisher. **C**
5. Remove screw securing front door finisher.
6. Remove clips securing front door finisher.
7. Lift out front door finisher. Disconnect harness connectors. **D**

Rear door finisher

8. Remove inside handle escutcheon. **E**
9. Remove screw securing pull handle, and then remove pull handle.
10. Remove power window switch finisher, then disconnect the connector. **F**
11. Remove clips securing rear door finisher.
12. Lift out rear door finisher. **G**

SEC. 251-267-809-828

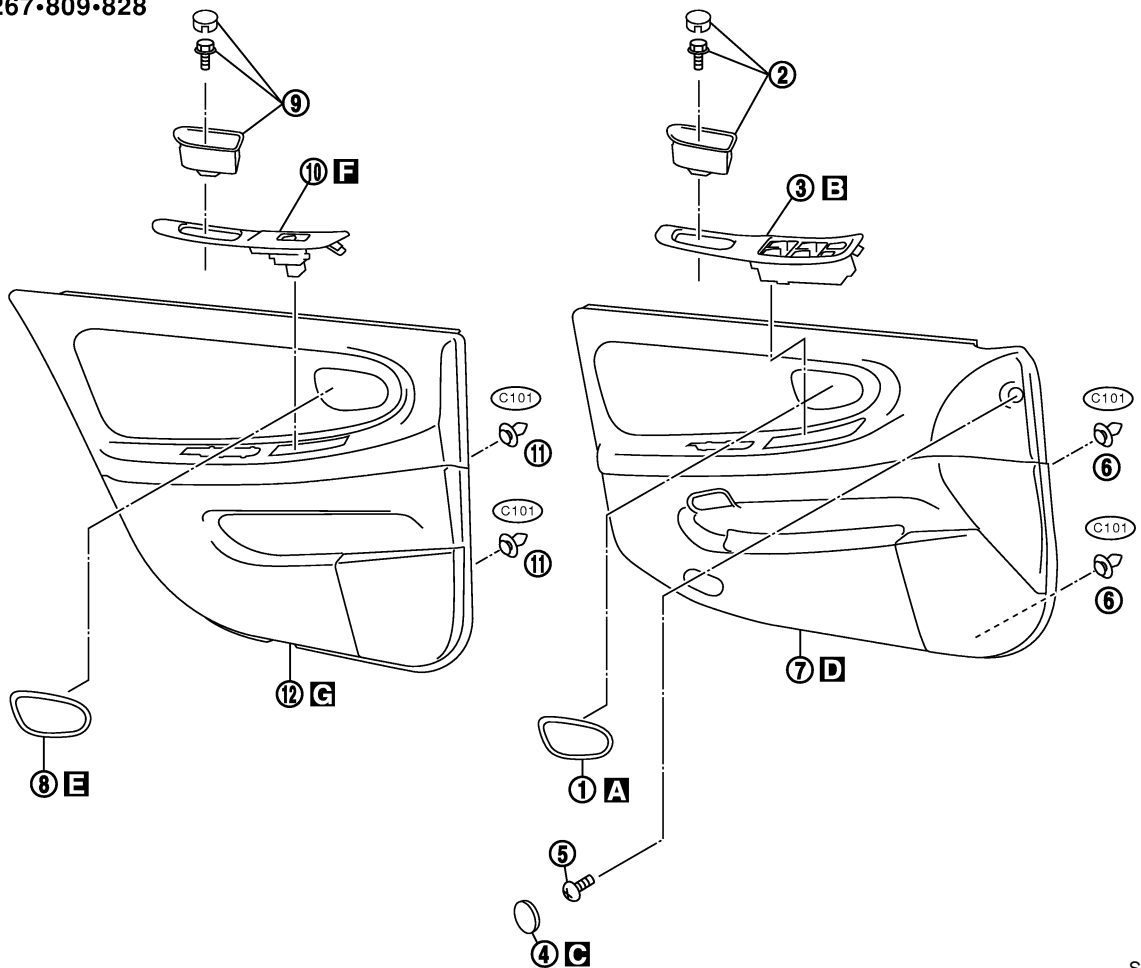

GI
MA
EM
LC
EC
FE
CL
MT
AT
AX
SU
BR
ST
RS
BT
HA
SC
EL
IDX

SBT800

DOOR TRIM

Removal and Installation (Cont'd)

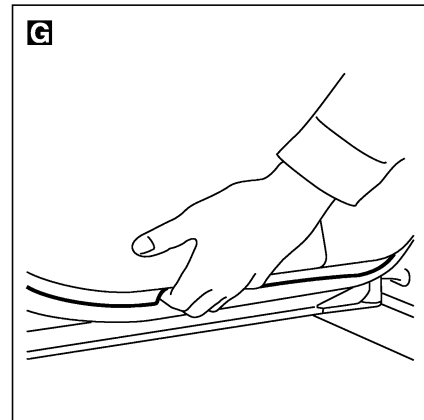
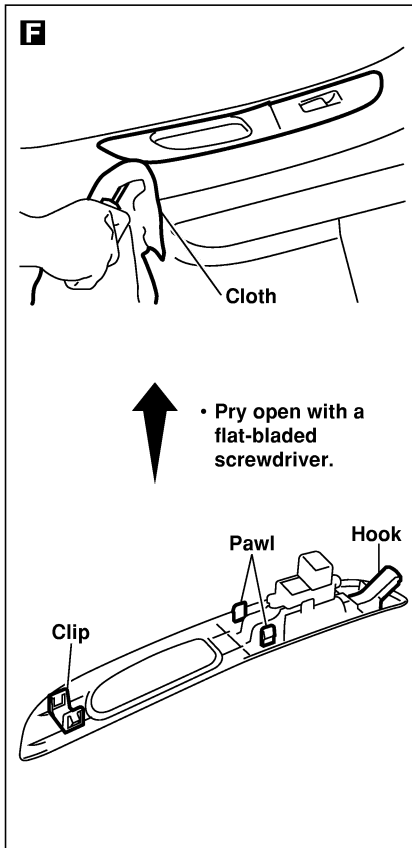
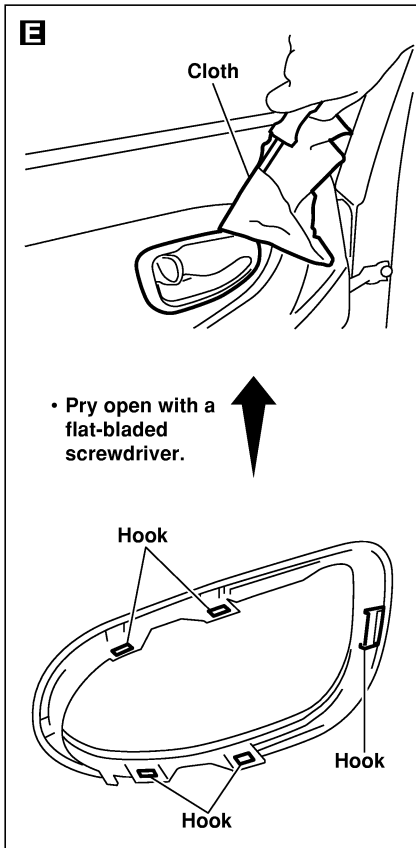
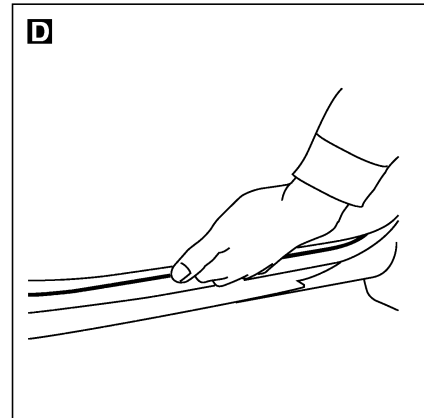
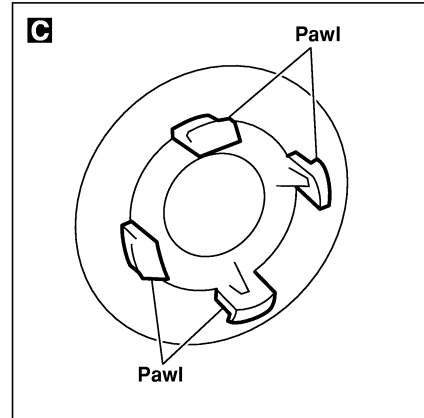
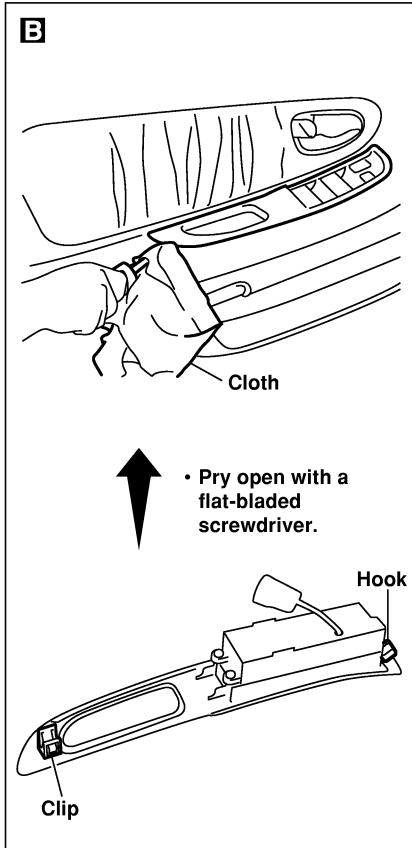
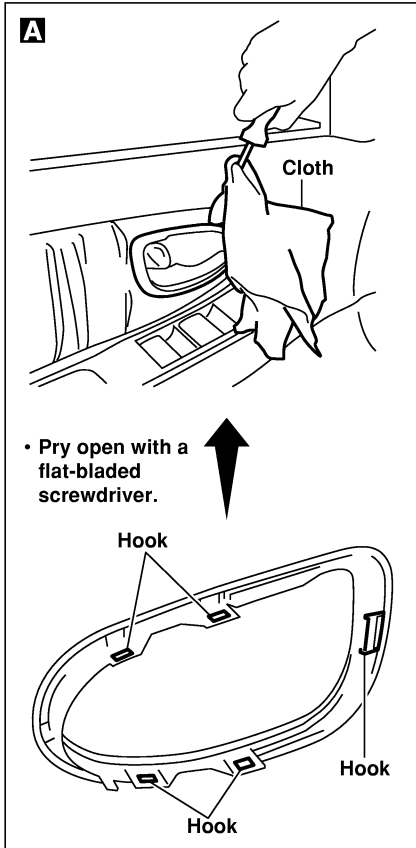

SBT801

Removal and Installation

NFBT0015

CAUTION:

When removing or installing body side welts, do not allow butyl seal to come in contact with pillar garnish and headlining.

1. Remove rear seats. Refer to "REAR SEAT" for details, BT-50.
2. Remove shoulder anchor bolts. Refer to RS-5, "Front Seat Belt" for details.
3. Remove front pillar garnishes, center pillar upper garnishes and rear pillar garnishes. Refer to "SIDE AND FLOOR TRIM" for details, BT-32.
4. Remove steering wheel. Refer to RS-20, "Driver Air Bag Module and Spiral Cable" for details.
5. Push back the front seat back.
6. Remove sunroof and spot lamp switch, then disconnect connectors. **A**
7. Remove roof console.
8. Remove sun visors.
9. Remove assist grips. **B**
10. Remove interior lamp assembly, then disconnect connectors. **C**
11. Remove metal clip securing headlining, then remove headlining from vehicle through front passenger side.

GI
MA
EM
LC
EC
FE
CL
MT
AT
AX
SU
BR
ST
RS
BT
HA
SC
EL
IDX

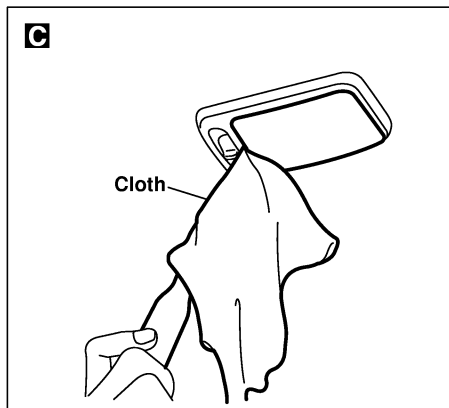
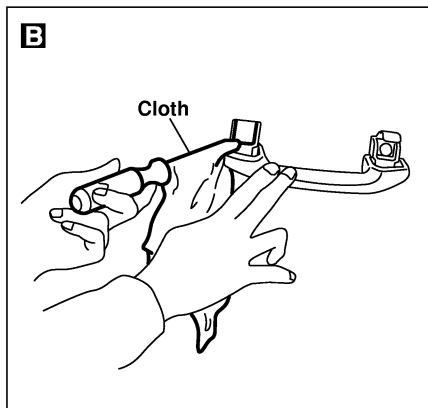
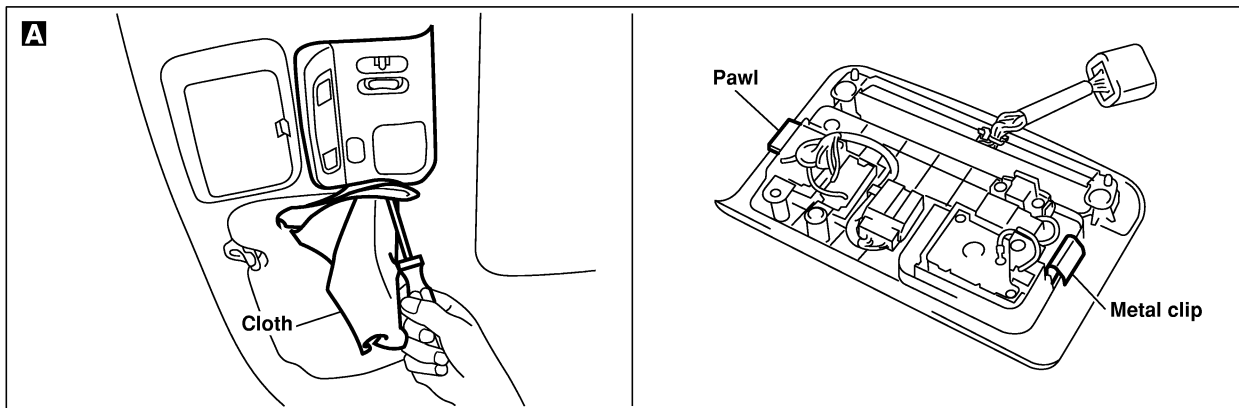

SBT802

ROOF TRIM

Removal and Installation (Cont'd)

SEC. 264-738-964

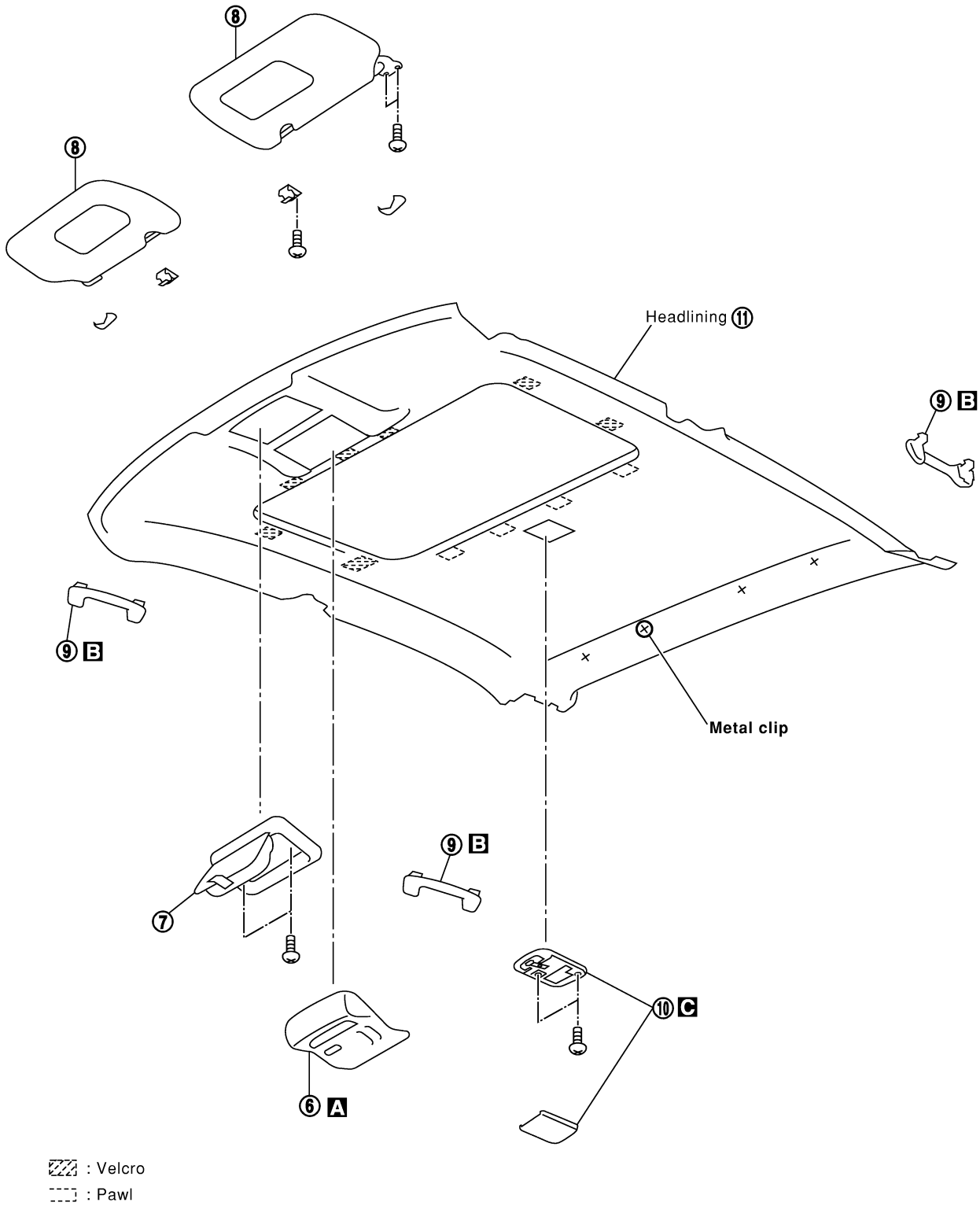

SBT803

TRUNK ROOM TRIM

Removal and Installation

Removal and Installation

NFBT0016

SEC. 849

GI
MA
EM
LC
EC
FE
CL
MT
AT
AX
SU
BR
ST
RS
BT
HA
SC
EL
IDX

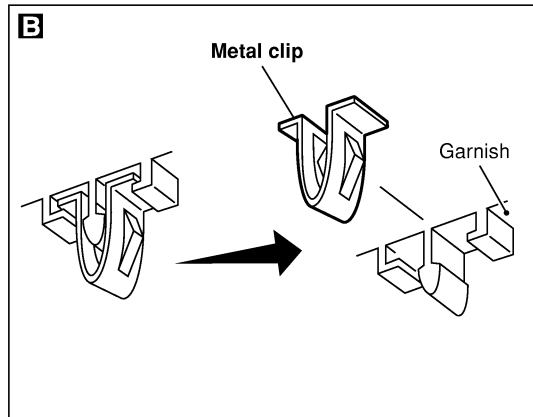
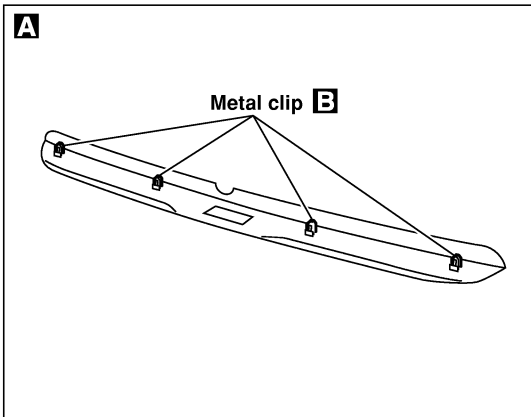
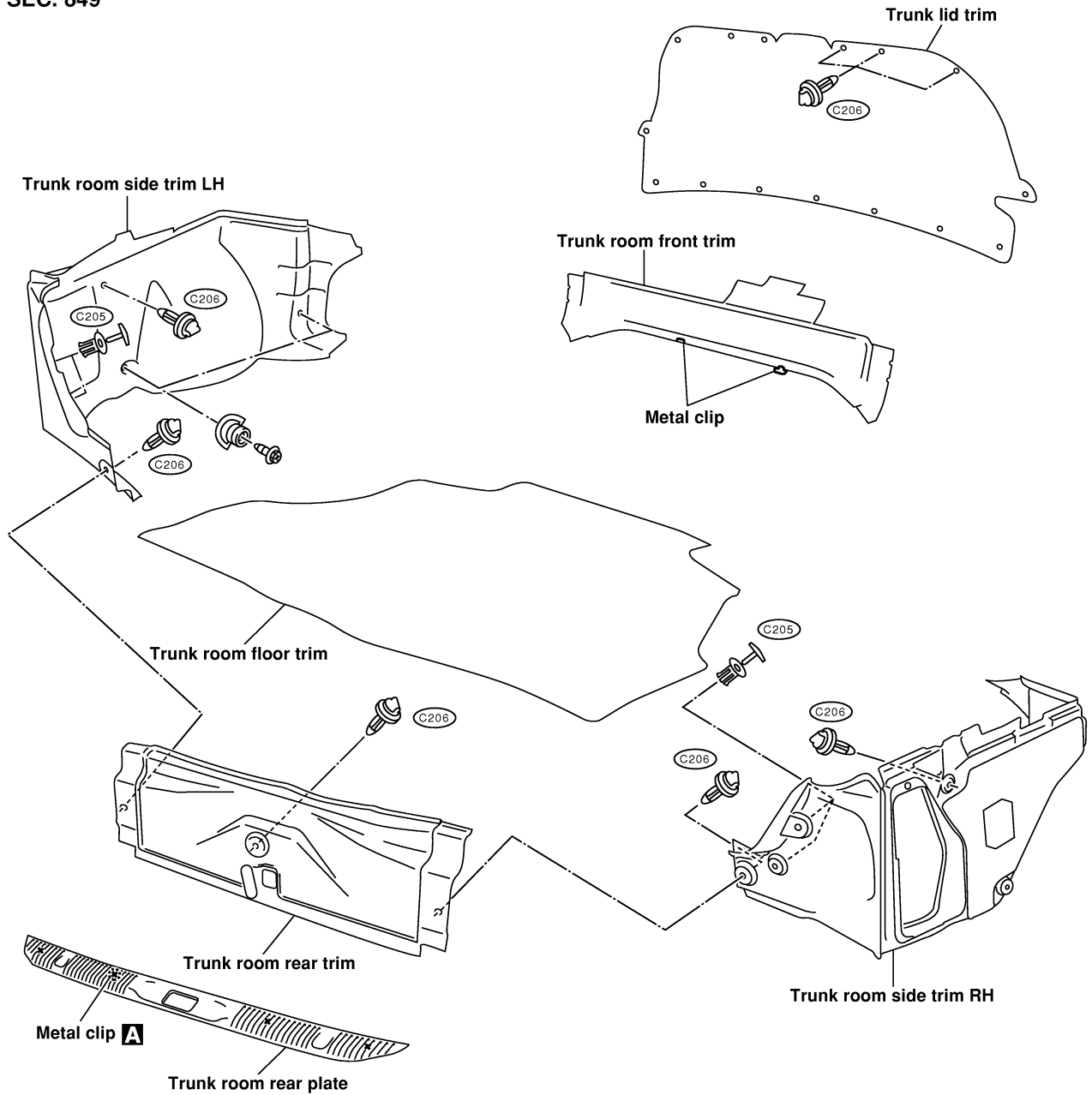

SBT804

Removal and Installation

NFBT0017

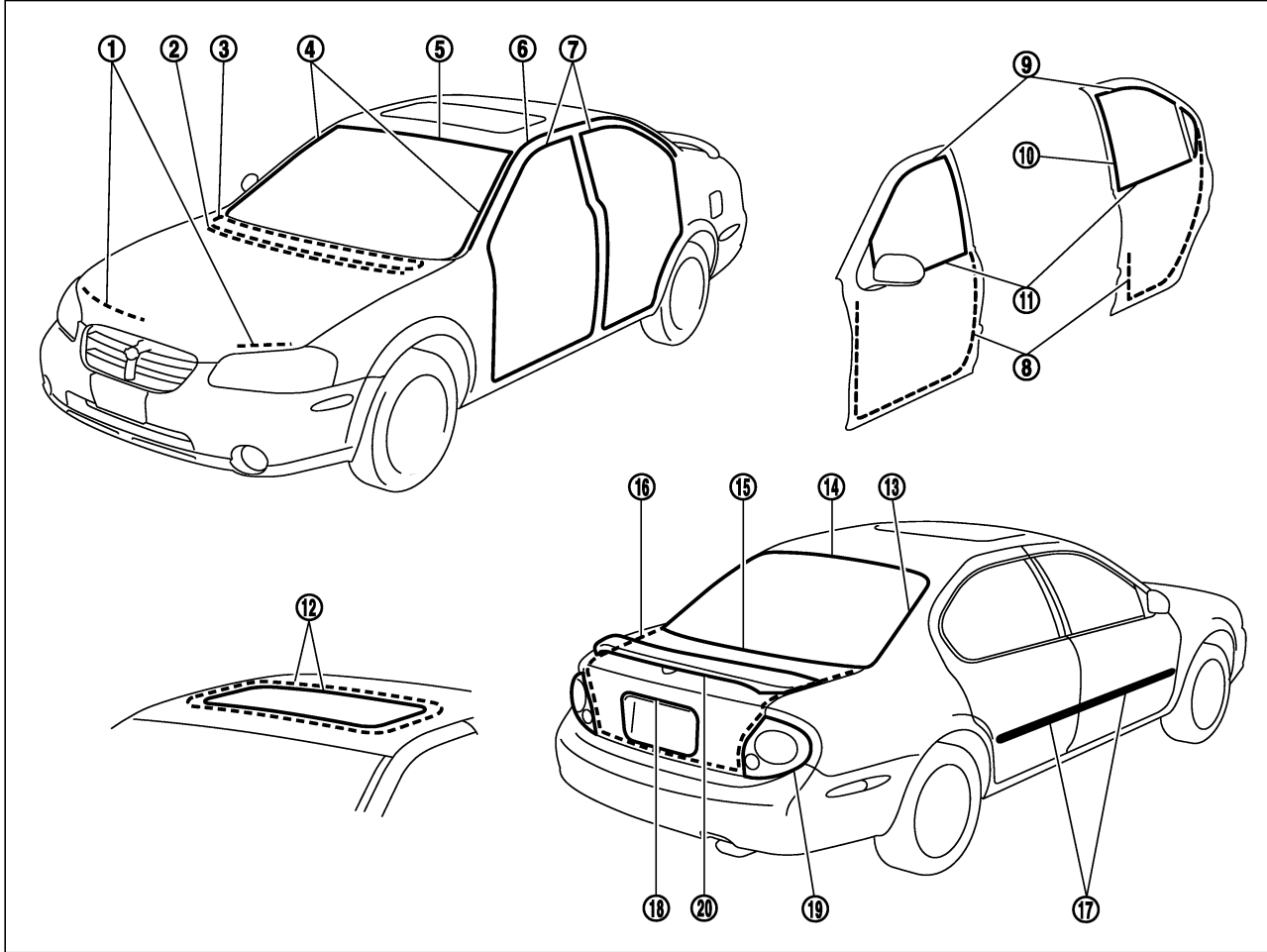

① Radiator core support sealing rubber

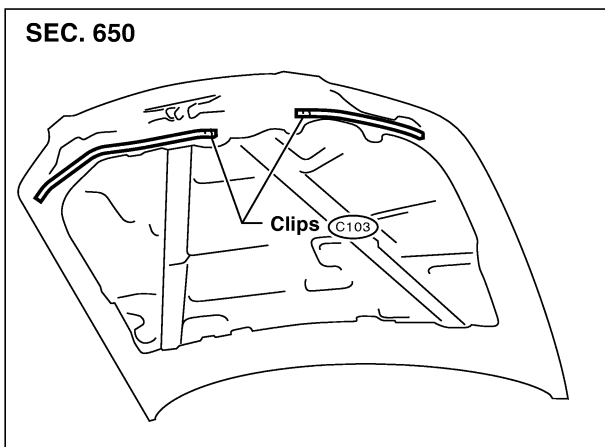

② ③ Cowl top seal and cowl top grille

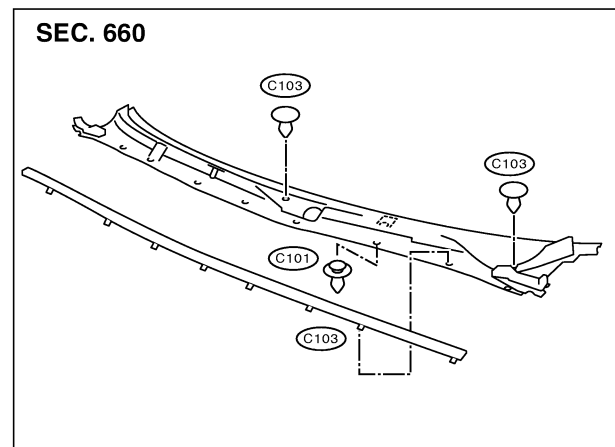

④ Windshield side molding
Mounted with screws.

⑤ Windshield upper molding

SEC. 720

1. Cut off adhesive at glass end.
2. Remove old adhesive from panel surface.
3. Set molding fastener and apply primer to body panel, and apply adhesive to body.

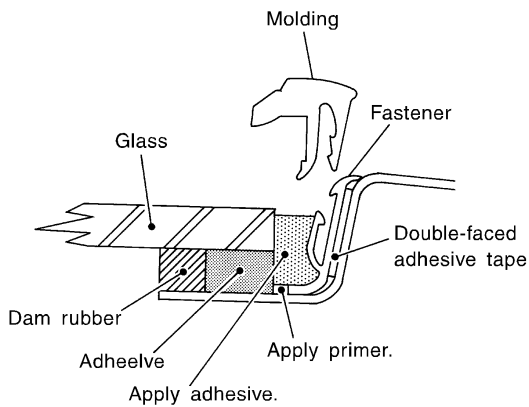
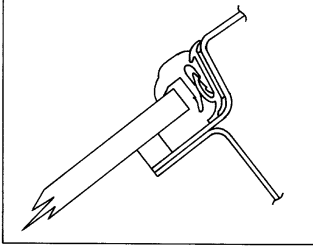

4. Install molding by aligning the molding mark located on center with vehicle center. Be sure to install tightly so that there is no gap around the corner.

⑦ Body side welt

SEC. 767

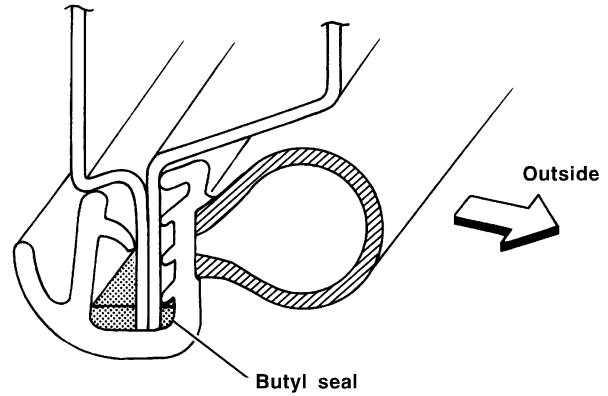

⑧ Door weatherstrip

SEC. 800•820

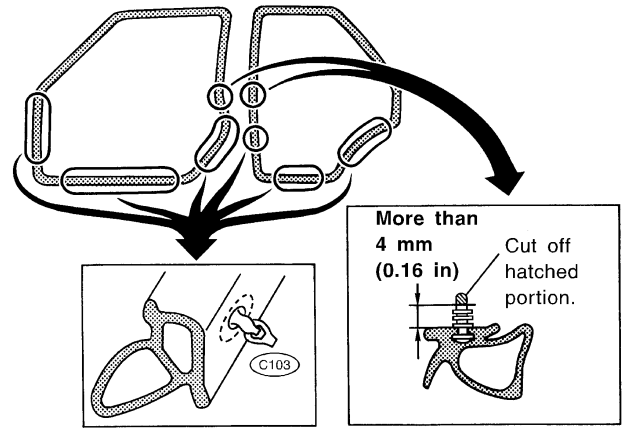

⑥ Drip weatherstrip

SEC. 767

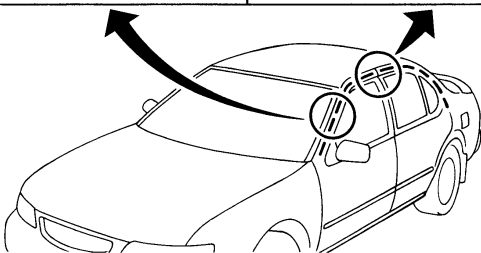
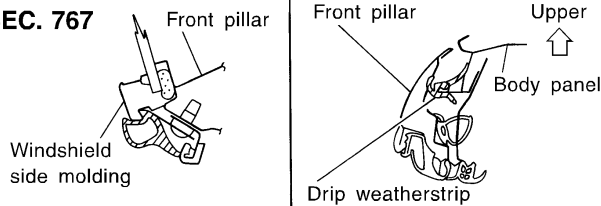

GI

MA

EM

LC

EC

FE

CL

MT

AT

AX

SU

BR

ST

RS

BT

HA

SC

EL

IDX

EXTERIOR

Removal and Installation (Cont'd)

⑨ Door sash molding

SEC. 800•820
Front

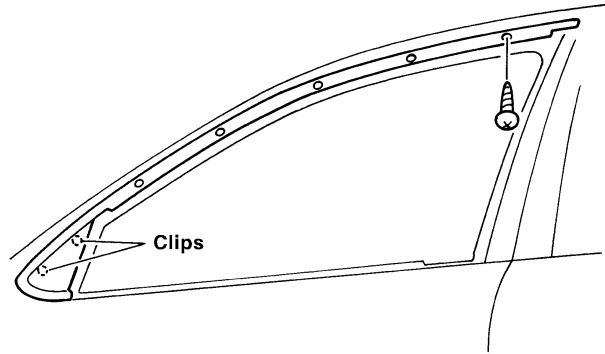

Rear

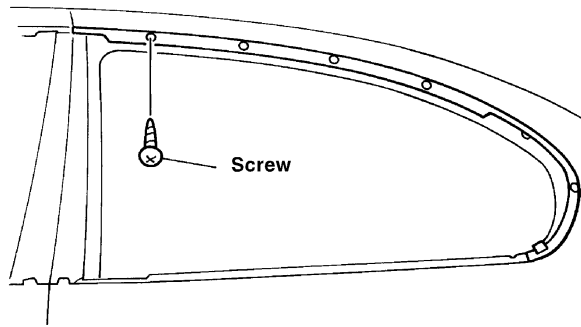

⑪ Door outside molding

Front door
SEC. 800

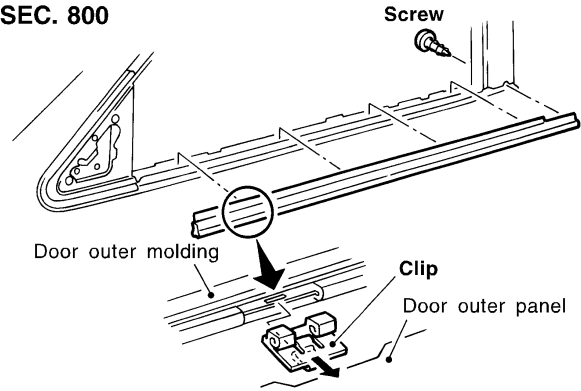

Rear door
SEC. 820

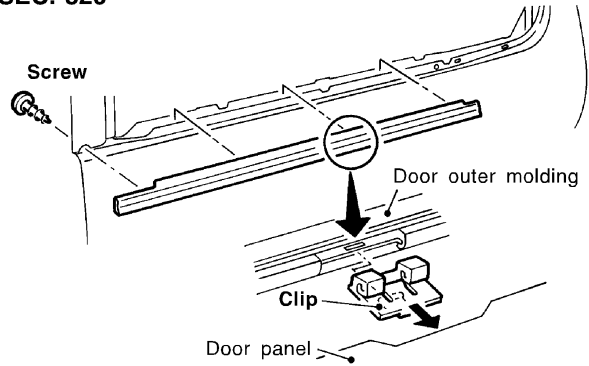

⑩ Front door parting seal

SEC. 800

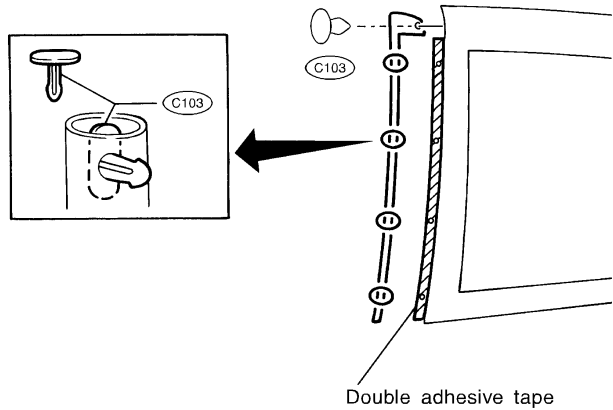

⑫ Sunroof lid weatherstrip

SEC. 736

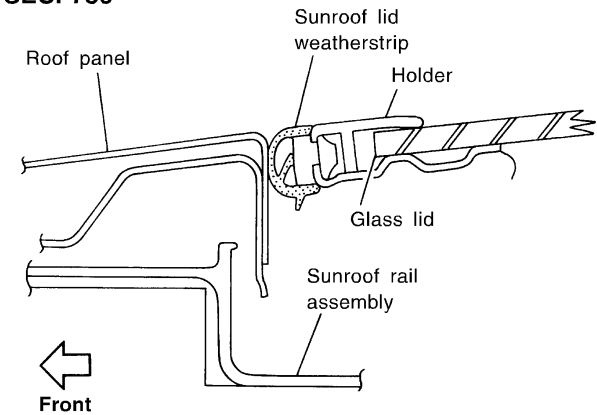

SBT807

⑬ ⑭ Rear window upper molding and side molding

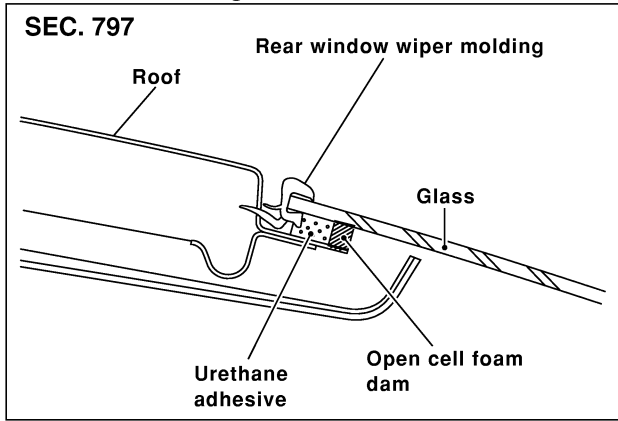

⑯ Trunk lid weatherstrip

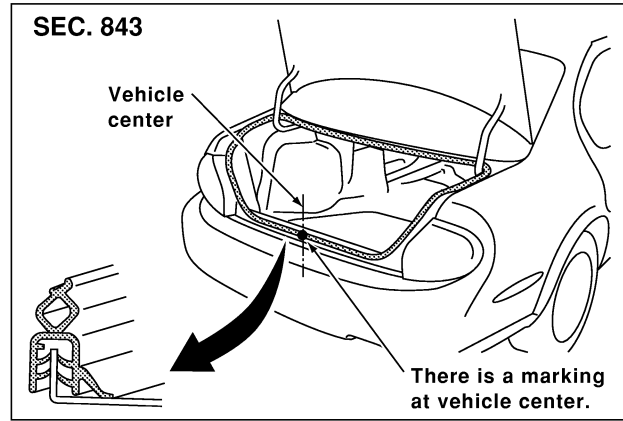

⑮ Rear window lower molding

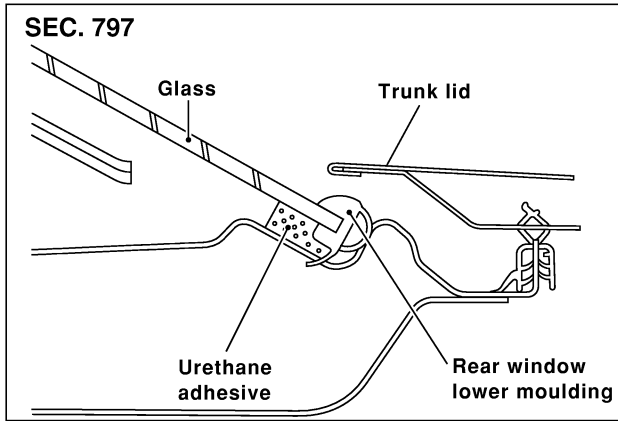

⑰ Side guard molding

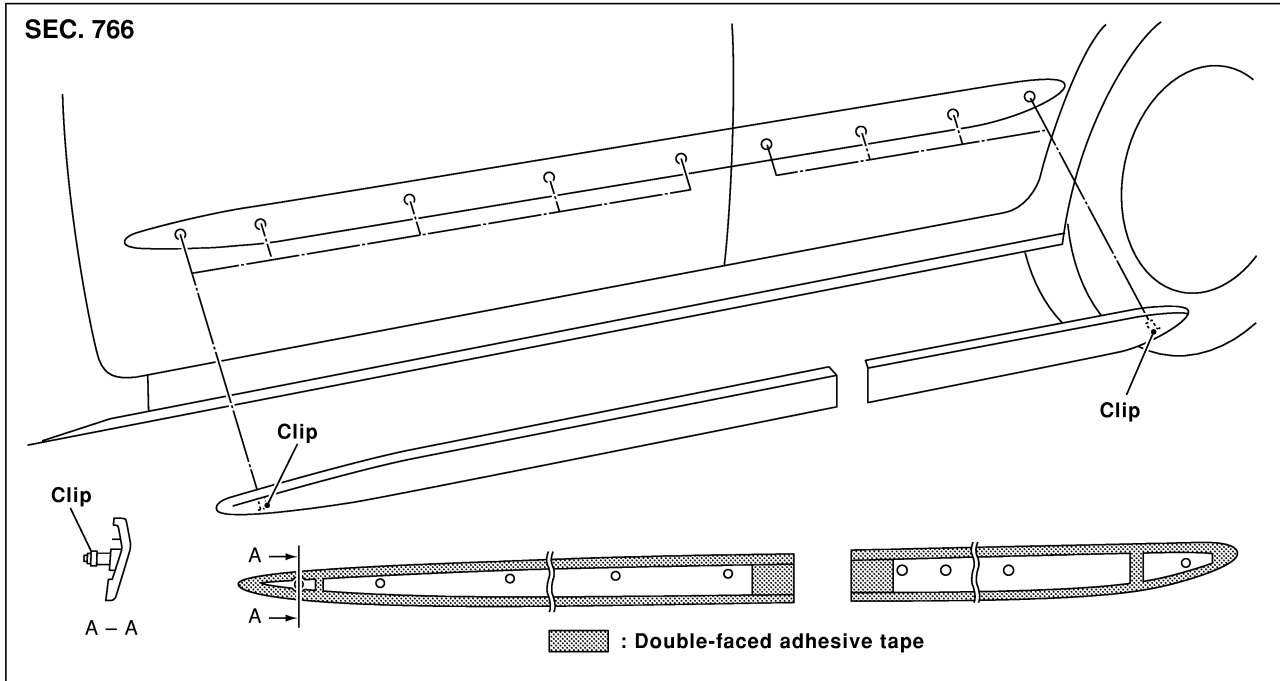

GI
MA
EM
LC
EC
FE
CL
MT
AT
AX
SU
BR
ST
RS
BT
HA
SC
EL
IDX

18 License plate finisher

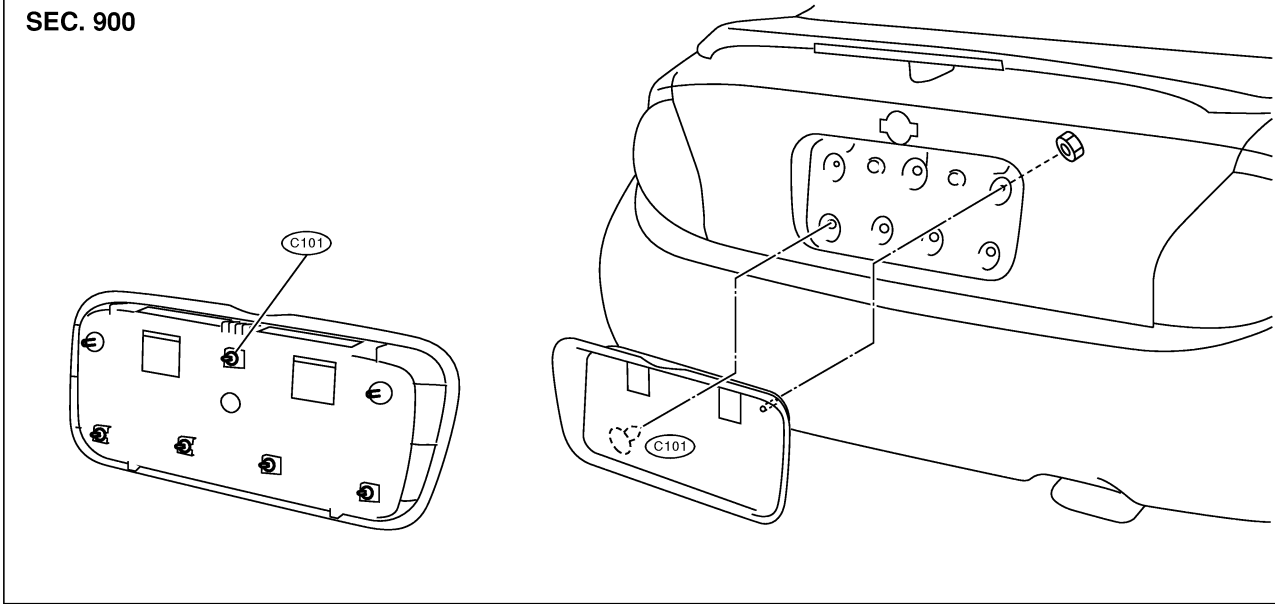

19 Rear combination lamp

- Rear combination lamps are installed with nuts and butyl seal.

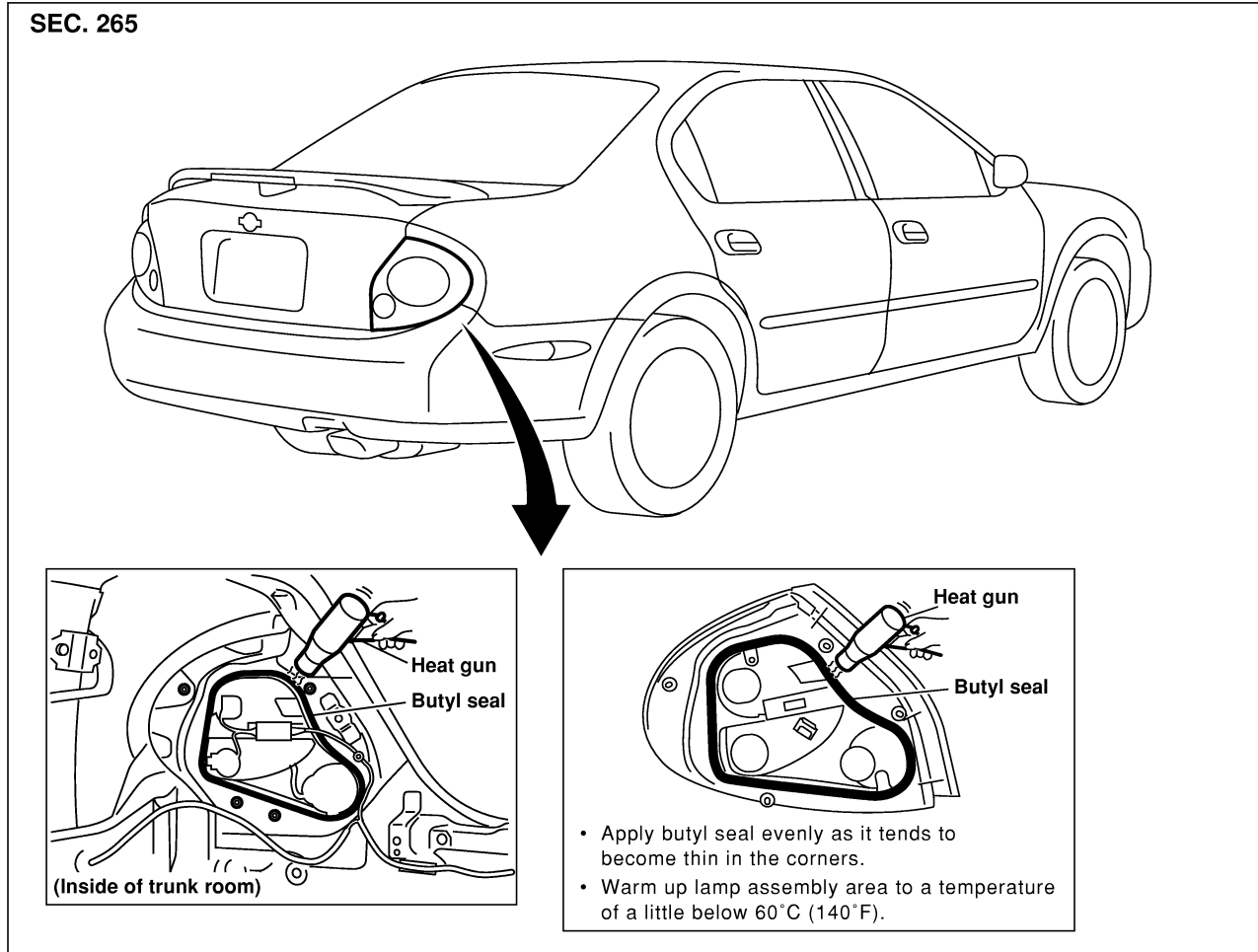

20 Rear air spoiler

- When removing, first disconnect high-mounted stop lamp connector located on the back of trunk lid, then remove air spoiler taking care the stop lamp harness does not get caught.
- When installing, make sure that there are not gaps or waves at ends of air spoiler.
- Before installing spoiler, clean and remove oil from surface where spoiler will be mounted.

GI
 MA
 EM
 LC
 EC
 FE
 CL
 MT
 AT
 AX
 SU
 BR
 ST
 RS
 BT
 HA
 SC
 EL
 IDX

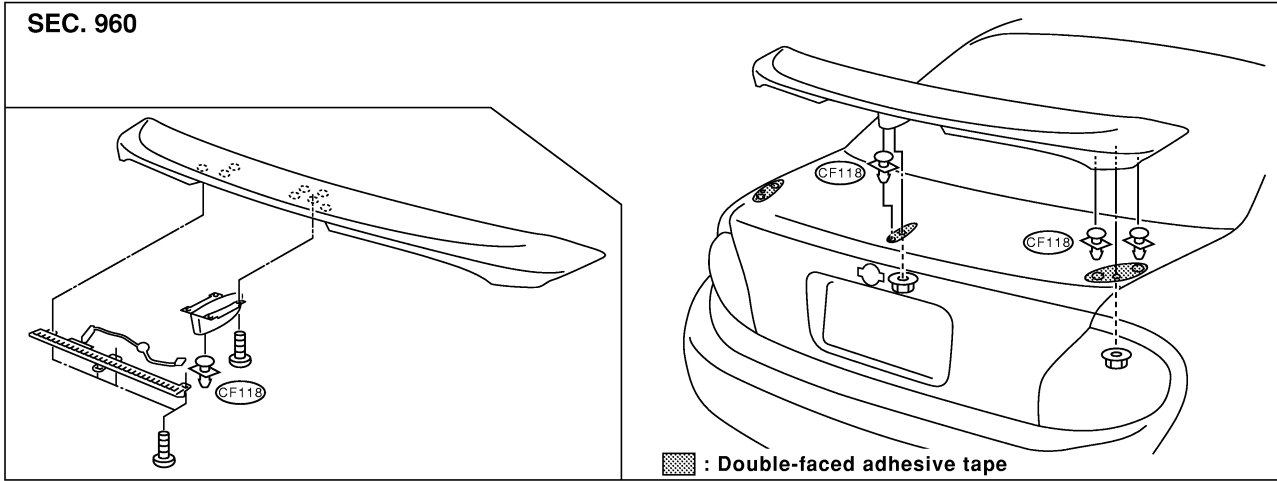

Removal and Installation

NFBT0018

- When removing or installing the seat trim, carefully handle it to keep dirt out and avoid damage.
- ★ For Wiring Diagram, refer to EL-187, “POWER SEAT” for details.

CAUTION:

- Before removing the front seat, turn the ignition switch off, disconnect both battery cables and wait at least 3 minutes.
- When checking the power seat circuit for continuity using a circuit tester, do not confuse its connector with the side air bag module connector. Such an error may cause the air bag to deploy.
- Do not drop, tilt, or bump the side air bag module installed in the seat. Always handle it with care.

FRONT SEAT

Removal and Installation (Cont'd)

POWER SEAT

SEC. 870

NFBT0018S01

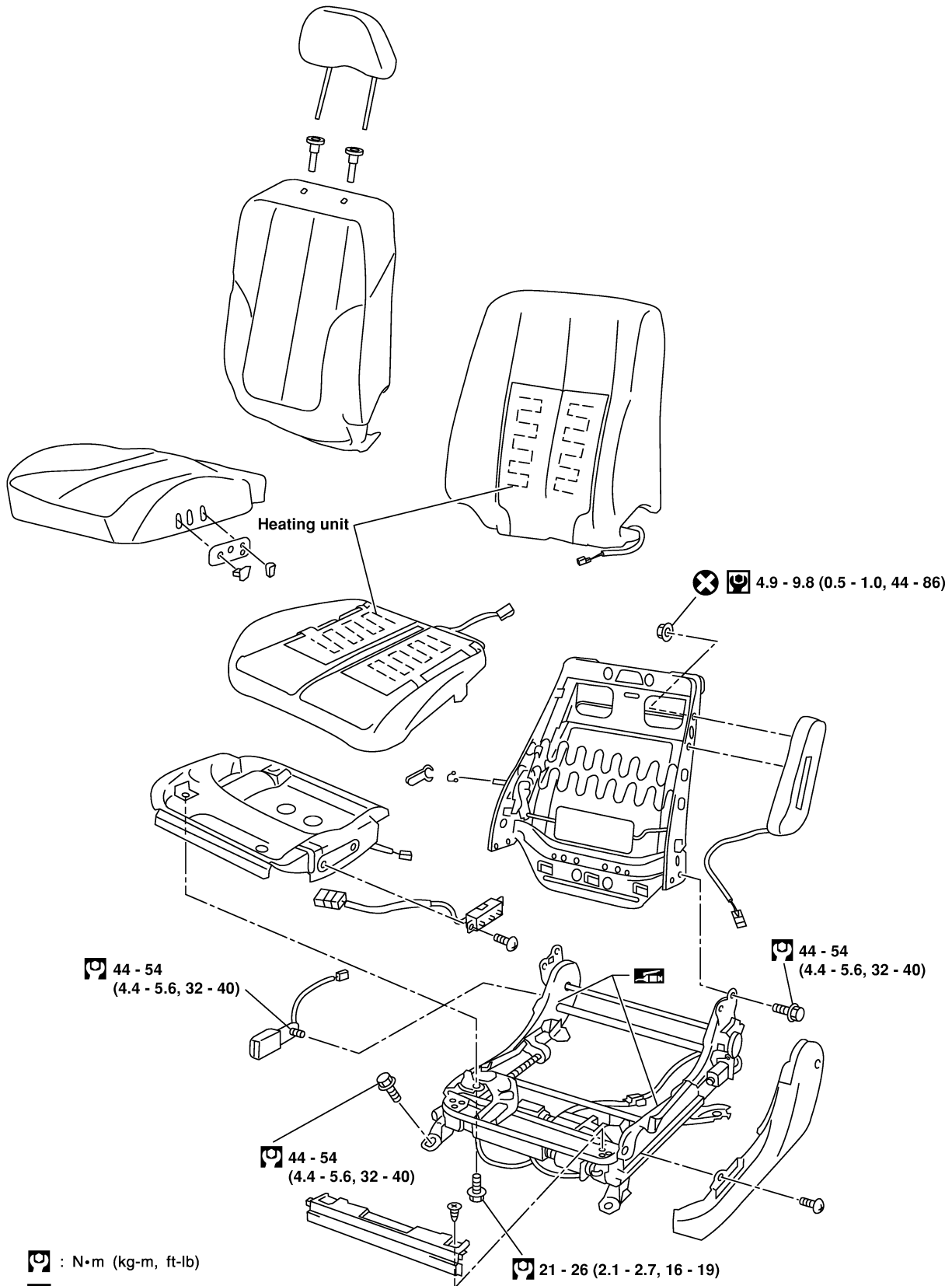

: N•m (kg-m, ft-lb)

: N•m (kg-m, in-lb)

- GI
- MA
- EM
- LC
- EC
- FE
- CL
- MT
- AT
- AX
- SU
- BR
- ST
- RS
- BT**
- HA
- SC
- EL
- IDX

SBT810

FRONT SEAT

Removal and Installation (Cont'd)

MANUAL SEAT

NFBT0018S02

SEC. 870

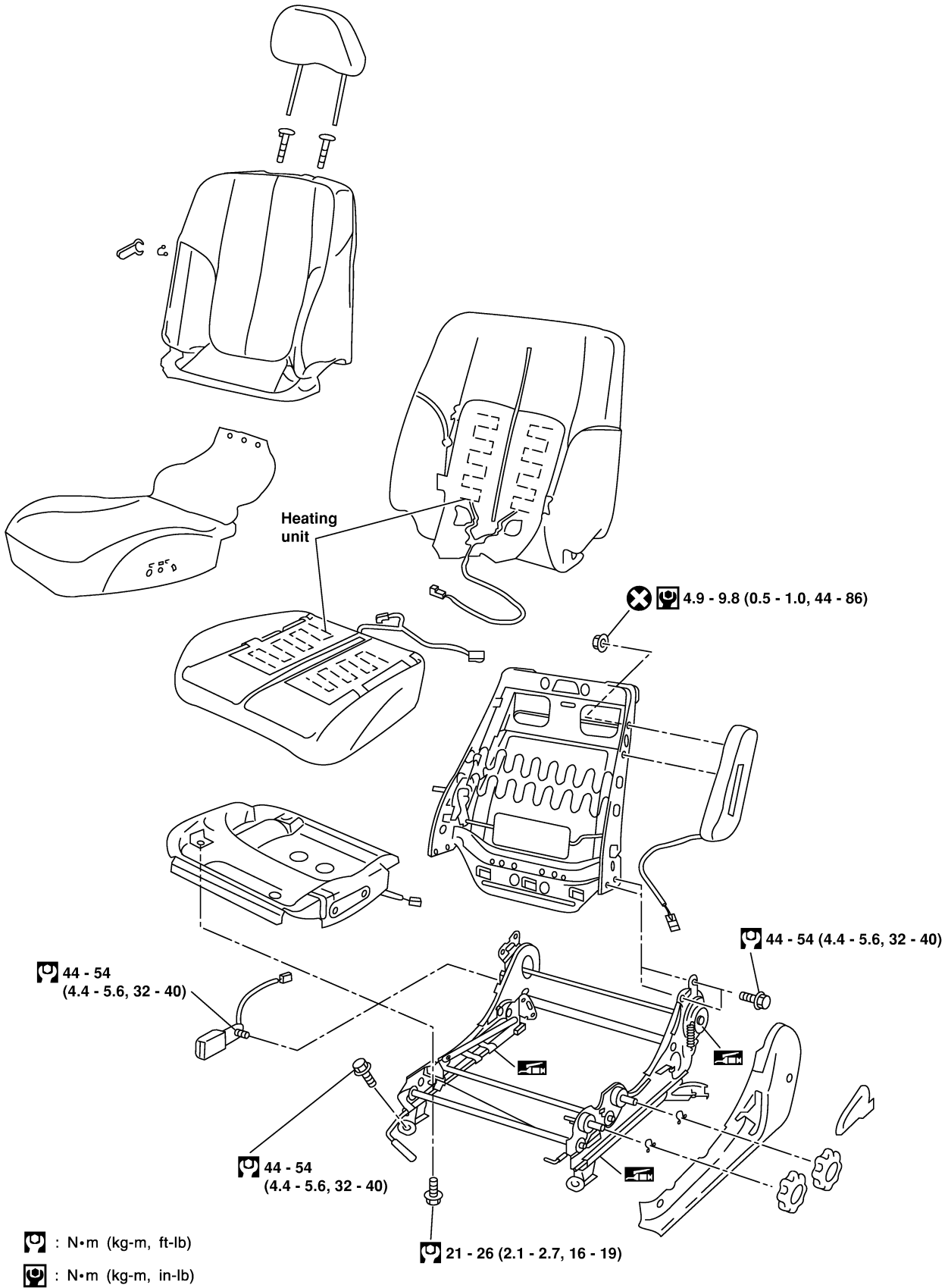

SBT811

HEATED SEAT

NFBT0018S03

- When handling seat, be extremely careful not to scratch heating unit.
 - To replace heating unit, seat trim and pad should be separated.
 - Do not use any organic solvent, such as thinner, benzene, alcohol, gasoline, etc. to clean trims.
- ★ For Wiring Diagram, refer to EL-190, "HEATED SEAT" for details.

GI

MA

EM

LC

EC

FE

CL

MT

AT

AX

SU

BR

ST

RS

BT

HA

SC

EL

IDX

REAR SEAT

Removal and Installation

Removal and Installation

NFBT0019

SEC. 880

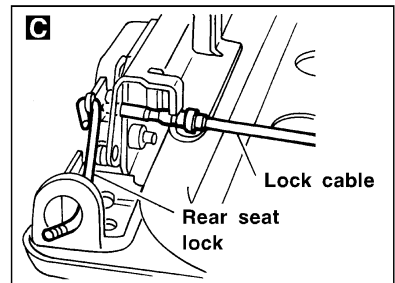
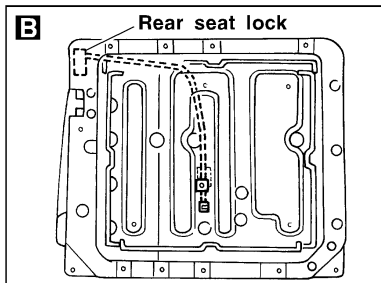
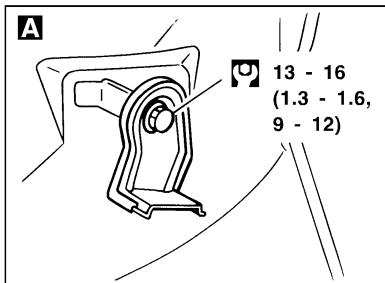
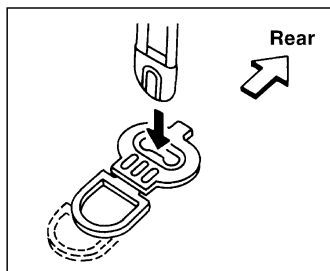
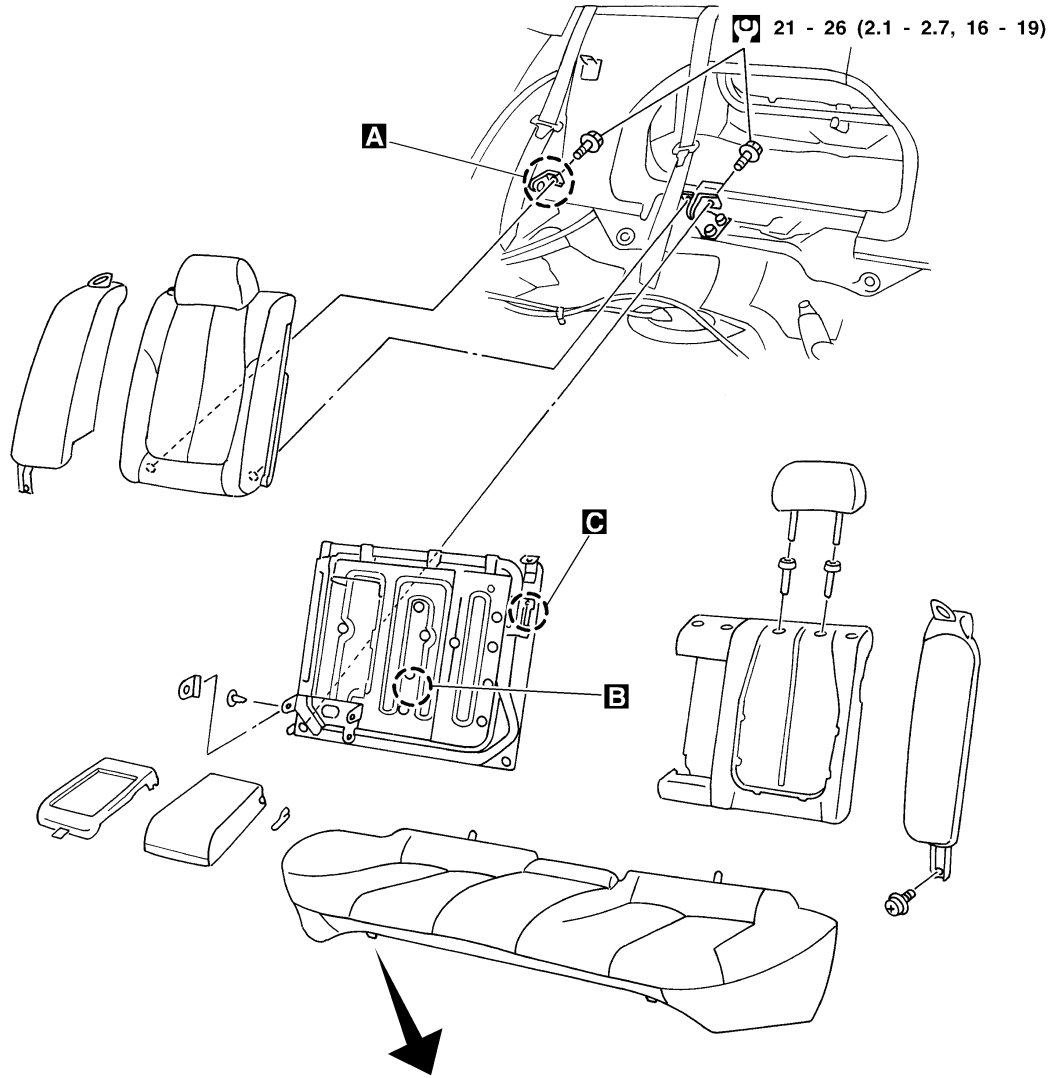

: N·m (kg-m, ft-lb)

SBT812

Adjustment

NFBT0020

Install motor & limit SW assembly and sunroof rail assembly in the following sequence:

1. Arrange equal lengths of link and wire assemblies on both sides of sunroof opening.
2. Connect sunroof connector to sunroof switch and positive (+) power supply.
3. Set lid assembly to fully closed position **A** by operating OPEN switch and TILT switch.
4. Fit outer side of lid assembly to the surface of roof on body outer panel.
5. Remove motor, and keep OPEN switch pressed until motor pinion gear reaches the end of its rotating range.
6. Install motor.
7. Check that motor drive gear fits properly in wires.
8. Press TILT-UP switch to check lid assembly for normal tilting.
9. Check sunroof lid assembly for normal operations (tilt-up, tilt-down, open, and close).

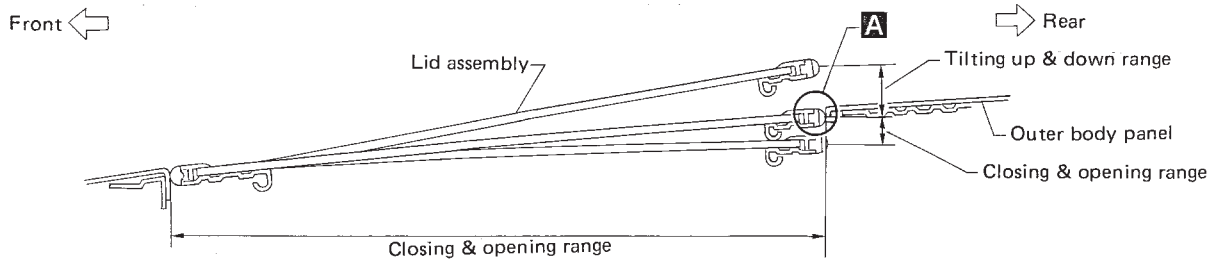

SBF920F

Removal

NFBT0021

- After any adjustment, check sunroof operation and lid alignment.
- Handle finisher plate and glass lid with care so not to cause damage.
- It is desirable for easy installation to mark each point before removal.

CAUTION:
Always work with a helper.

GI
MA
EM
LC
EC
FE
CL
MT
AT
AX
SU
BR
ST
RS
BT
HA
SC
EL
IDX

SUNROOF

Removal (Cont'd)

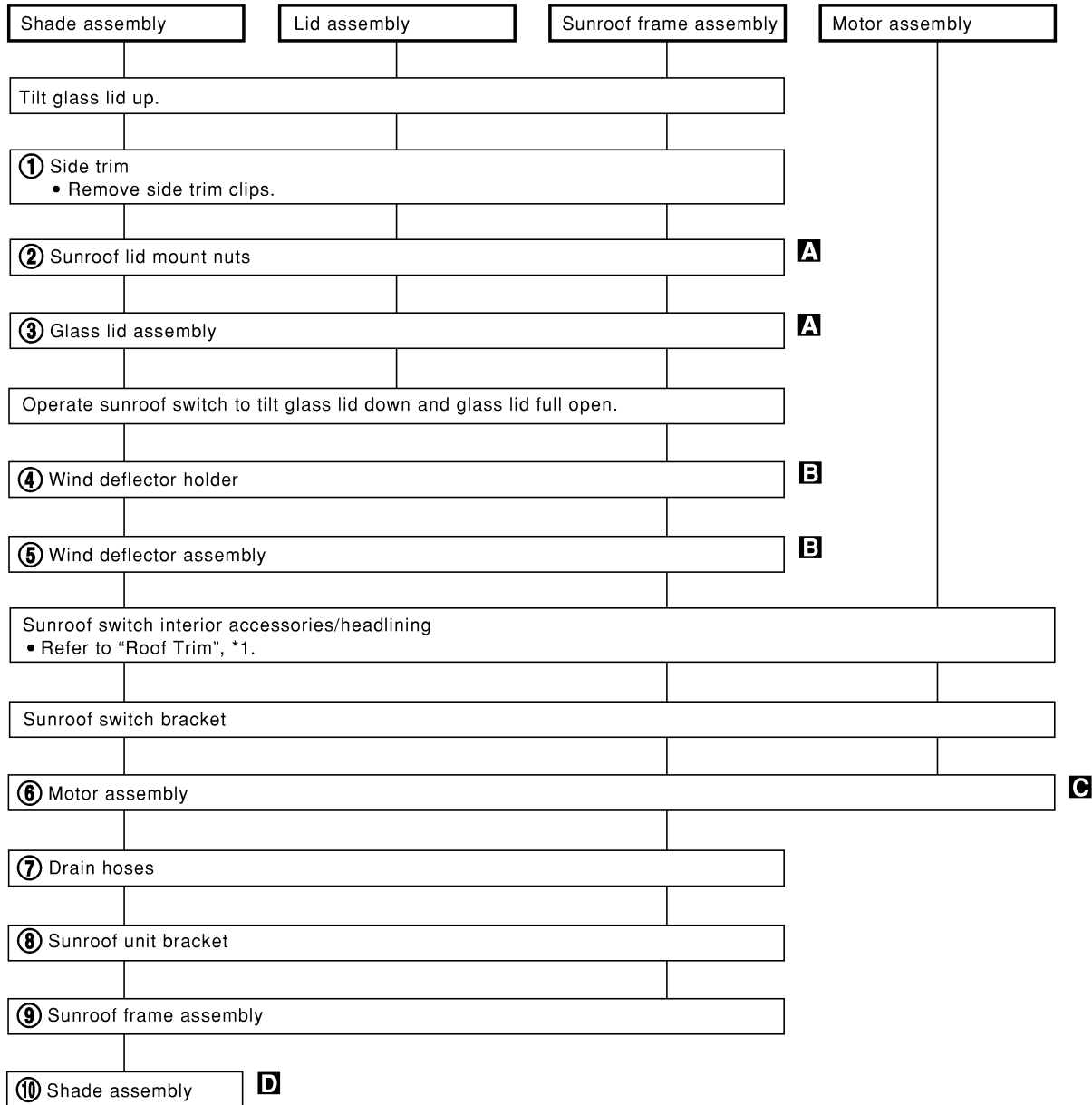

★ For Wiring Diagram, refer to (*2), "POWER SUNROOF" for details.

SBT838

*1 BT-37

*2 EL-179

SUNROOF

Removal (Cont'd)

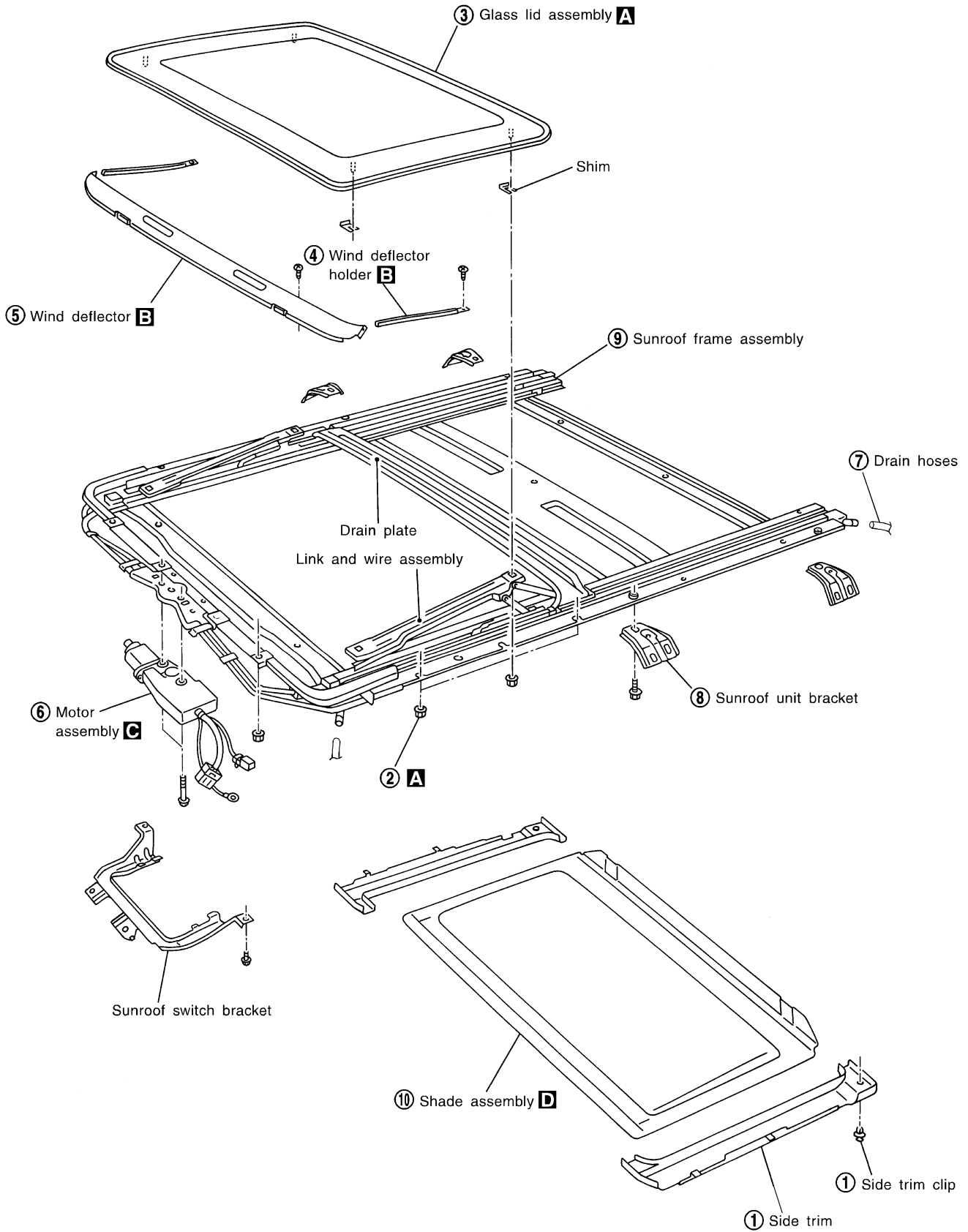

GI
 MA
 EM
 LC
 EC
 FE
 CL
 MT
 AT
 AX
 SU
 BR
 ST
 RS
BT
 HA
 SC
 EL
 IDX

SBT825

SUNROOF

Removal (Cont'd)

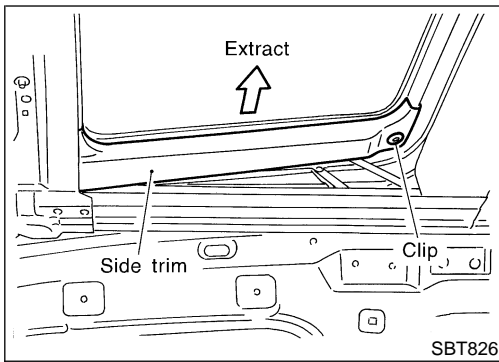

A Record the number of shims placed between glass lid assembly and link and wire assembly. Remove securing nuts and glass lid assembly.

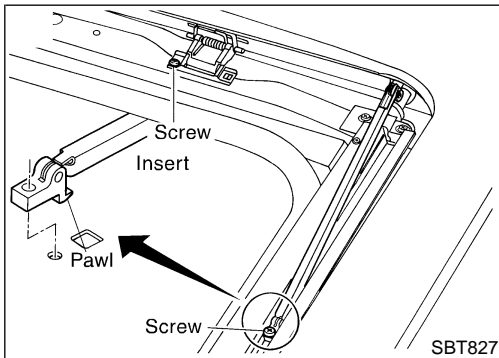

B Remove screws from left and right sides of each wind deflector holder. Extract pawls through rail holes, then remove left and right sides of wind deflector holder. Remove screws from front end of sunroof unit. Extract pawls through frame holes, then remove wind deflector from frame assembly.

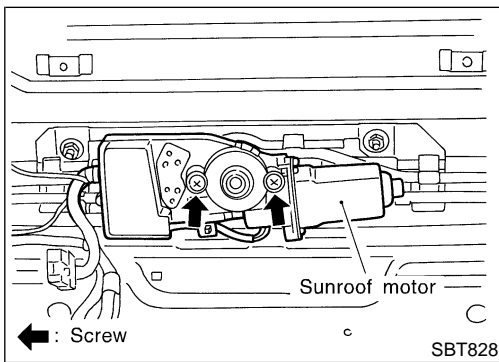

C

CAUTION:

- Before removing sunroof motor, make sure that sunroof is fully closed.
- After removing sunroof motor, never attempt to rotate sunroof motor as a single unit.

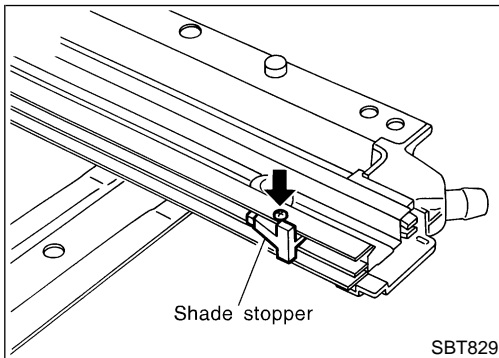

D Remove shade stoppers (2 points) from rear end of sunroof frame assembly. Remove sun shade from rear end of sunroof frame assembly.

Trouble Diagnoses DIAGNOSTIC TABLE

=NFBT0022

NFBT0022S01

NOTE:

For diagnosing electric problem, refer to "ELECTRIC SUNROOF" in EL section.

		Check items (Components)				
		Wind deflector	Adjustment	Drain hoses	Weatherstrip	Link and wire assembly
	Reference page	BT-55	BT-56	BT-57	BT-57	BT-58
Symptom	Excessive wind noise	1	2		3	
	Water leaks		1	2	3	
	Sunroof rattles		1	4	2	3
	Excessive operation noise		1		2	3

The numbers in this table mean checking order.

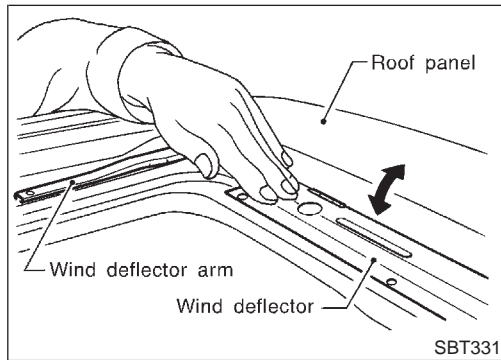

WIND DEFLECTOR

NFBT0022S02

1. Open lid.
2. Check visually for proper installation.
3. Check to ensure a proper amount of petroleum jelly has been applied to wind deflector connection points; apply if necessary.
4. Check that wind deflector is properly retracted by hand. If it is not, remove and visually check condition. (Refer to removal procedures, BT-51.) If wind deflector is damaged, replace with new one. If wind deflector is not damaged, re-install properly.

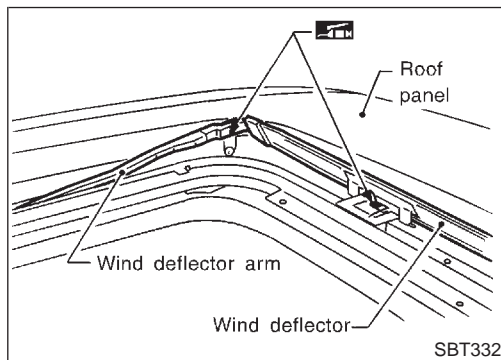

GI
MA
EM
LC
EC
FE
CL
MT
AT
AX
SU
BR
ST
RS
BT
HA
SC
EL
IDX

SUNROOF

Trouble Diagnoses (Cont'd)

ADJUSTMENT

NFBT0022S03

SEC. 736

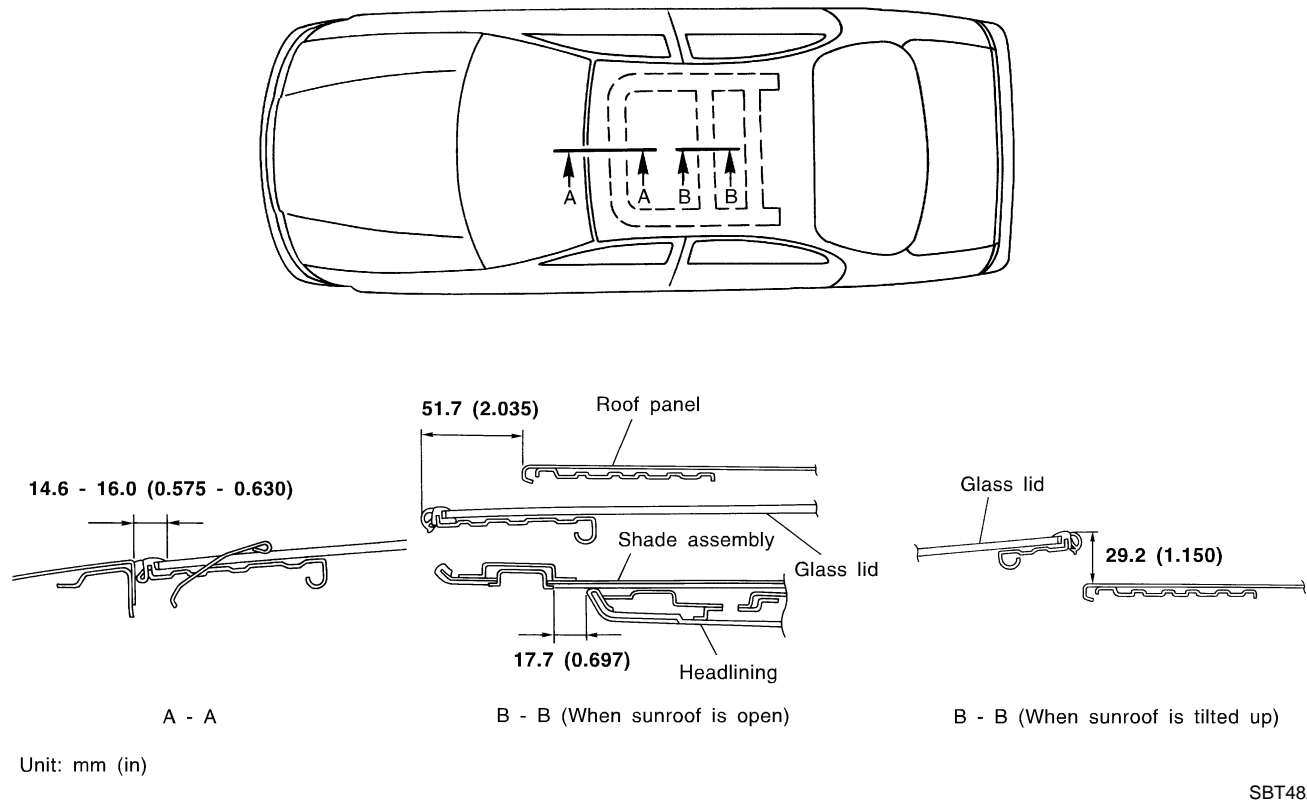

If any gap or height difference between glass lid and roof is found, check glass lid fit and adjust as follows:

Gap Adjustment

NFBT0022S0301

1. Open shade assembly.
2. Tilt glass lid up then remove side trim.
3. Loosen glass lid securing nuts (3 each on left and right sides), then tilt glass lid down.
4. Adjust glass lid from outside of vehicle so it resembles "A-A" as shown in the figure above.
5. Tilt glass lid up and down until it is adjusted to "B-B" as shown in the figure above.
6. After adjusting glass lid, tilt glass lid up and tighten nuts.
7. Tilt glass lid up and down several times to check that it moves smoothly.

Height Difference Adjustment

NFBT0022S0302

1. Tilt glass lid up and down.
2. Check height difference between roof panel and glass lid to see if it is as "A-A" as shown in the figure above.
3. If necessary, adjust it by using one of following procedures.
 - Adjust by adding or removing adjustment shim(s) between glass lid and link assembly.
 - If glass lid protrudes above roof panel, add shim(s) or plain washer(s) at sunroof mounting bracket or stud bolt locations to adjust sunroof installation as required.

DRAIN HOSES

NFBT0022S04

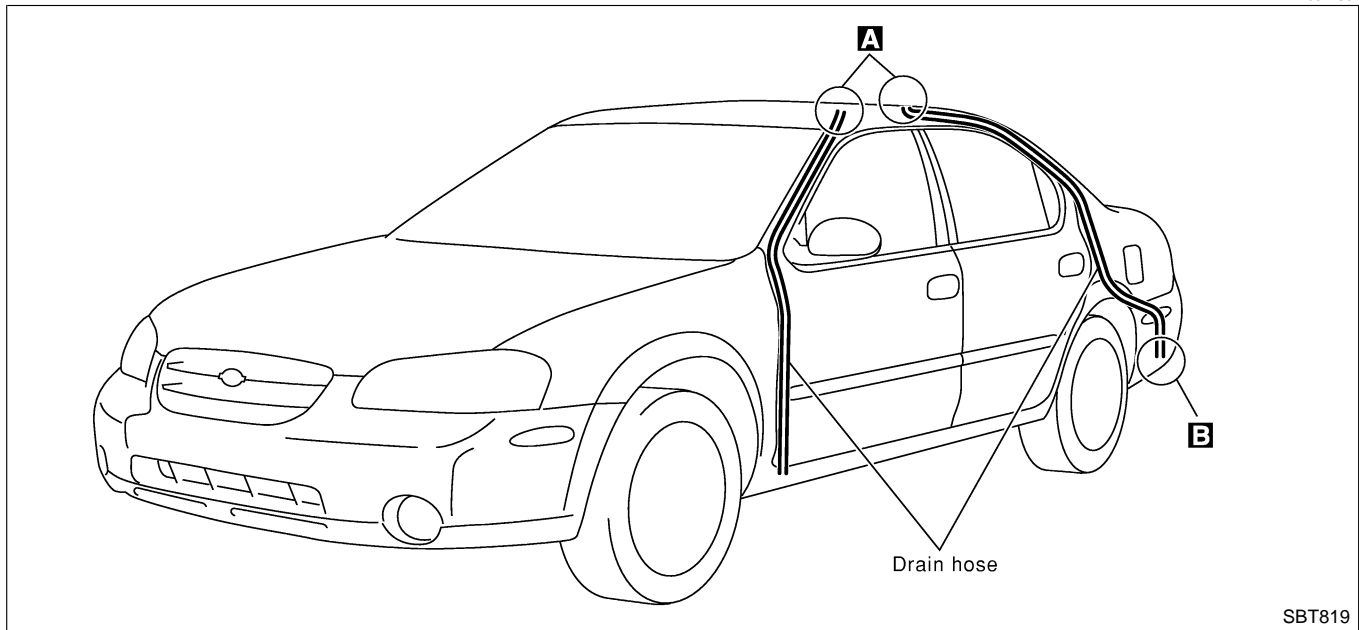

SBT819

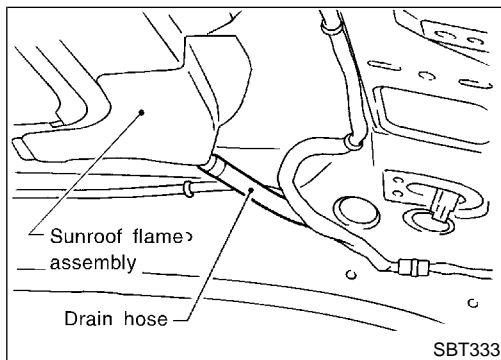

SBT333

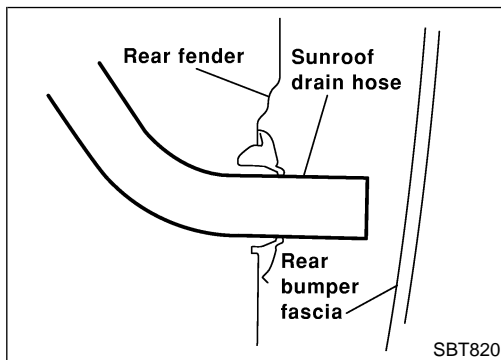

SBT820

1. Remove headlining to access drain hose connections. (Refer to "ROOF TRIM", BT-37, for detail.)
2. Check visually for proper connections, damage or deterioration. **A** (The figure shows only the front side.)

3. If leakage occurs around luggage room, remove luggage room side trim and check connecting area. Check for proper connection, damage or tear. **B**
4. Remove drain hoses and check visually for any damage, cracks, or deterioration.
5. Pour water into drain hoses and find damaged portion.
 - If any damaged portion is found at each step, replace the damaged part.

WEATHERSTRIP

NFBT0022S05

- In the case of leakage around glass lid, close glass lid and pour water over glass lid to find damaged or gap portion.
1. Remove glass lid assembly. (Refer to removal procedures, BT-51, for details.)
 2. Visually check weatherstrip for proper installation. If a gap exists between glass lid and weatherstrip, check for sufficient amount of butyl seal. If required, remove weatherstrip and apply butyl seal. Refer to "EXTERIOR", BT-40, for details.

GI
MA
EM
LC
EC
FE
CL
MT
AT
AX
SU
BR
ST
RS
BT
HA
SC
EL
IDX

3. Check weatherstrip visually for any damage, deterioration, or flattening.
 - If any damage is found, replace weatherstrip.

CAUTION:

Do not remove weatherstrip except when replacing, or filling up butyl seal.

LINK AND WIRE ASSEMBLY

NFBT0022S06

NOTE:

Before replacing a suspect part, carefully ensure it is the source of noise being experienced.

1. Check link to determine if coating film has peeled off to such an extent that substrate is visible. Check also to determine if link is the source of noise. If it is, replace it.
2. Visually check to determine if a sufficient amount of petroleum jelly has been applied to wire or rail groove. If not, add petroleum jelly as required.
3. Check wire for any damage or deterioration. If any damage is found, remove rear guide (refer to removal procedures, BT-51, for details), then replace wire.

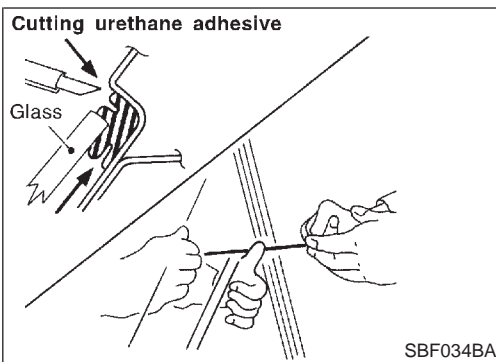

Removal and Installation

NFBT0023

REMOVAL

NFBT0023S01

After removing moldings, remove glass using piano wire or power cutting tool and an inflatable pump bag.

WARNING:

When cutting the glass from the vehicle, always wear safety glasses and heavy gloves to help prevent glass splinters from entering your eyes or cutting your hands.

CAUTION:

- Be careful not to scratch the glass when removing.
- Do not set or stand the glass on its edge. Small chips may develop into cracks.

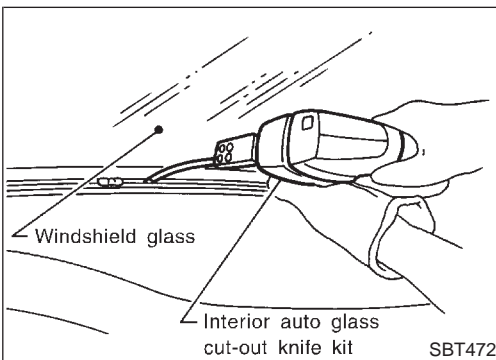

INSTALLATION

NFBT0023S02

- Use a genuine Nissan Urethane Adhesive Kit or equivalent and follow the instructions furnished with it.
- While the urethane adhesive is curing, open a door window. This will prevent the glass from being forced out by passenger compartment air pressure when a door is closed.
- The molding must be installed securely so that it is in position and leaves no gap.
- Inform the customer that the vehicle should remain stationary until the urethane adhesive has completely cured (preferably 24 hours). Curing time varies with temperature and humidity.

WARNING:

- Keep heat and open flames away as primers and adhesive are flammable.
- The materials contained in the kit are harmful if swallowed, and may irritate skin and eyes. Avoid contact with the skin and eyes.
- Use in an open, well ventilated location. Avoid breathing the vapors. They can be harmful if inhaled. If affected by vapor inhalation, immediately move to an area with fresh air.
- Driving the vehicle before the urethane adhesive has completely cured may affect the performance of the windshield in case of an accident.

CAUTION:

- Do not use an adhesive which is past its usable term. Shelf life of this product is limited to six months after the date of manufacture. Carefully adhere to the expiration or manufacture date printed on the box.
- Keep primers and adhesive in a cool, dry place. Ideally, they should be stored in a refrigerator.

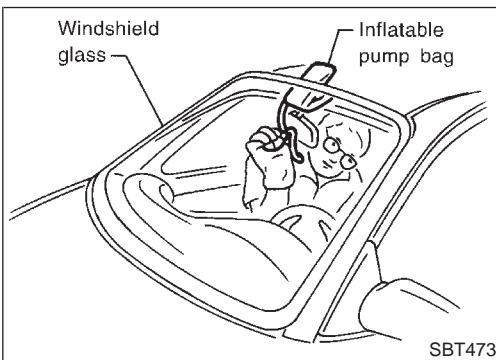

GI
MA
EM
LC
EC
FE
CL
MT
AT
AX
SU
BR
ST
RS
BT
HA
SC
EL
IDX

WINDSHIELD AND WINDOWS

Removal and Installation (Cont'd)

- Do not leave primers or adhesive cartridge unattended with their caps open or off.
- The vehicle should not be driven for at least 24 hours or until the urethane adhesive has completely cured. Curing time varies depending on temperature and humidities. The curing time will increase under higher temperatures and lower humidities.

WINDSHIELD

NFBT0023S03

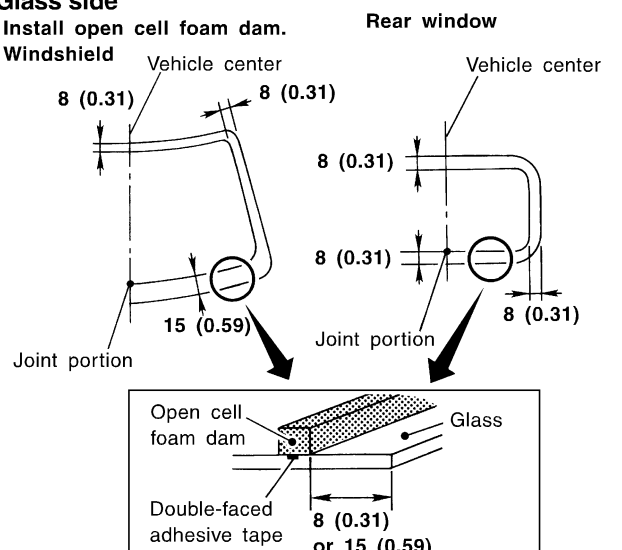
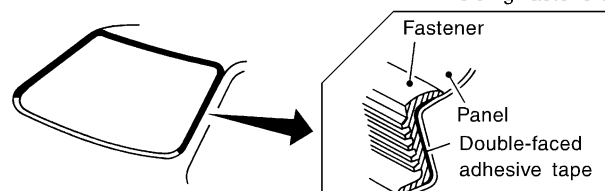
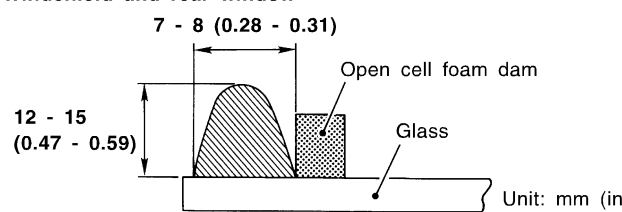
<p>Glass side Install open cell foam dam. Windshield</p>  <p>Rear window</p> <p>Vehicle center</p> <p>Vehicle center</p> <p>Joint portion</p> <p>Joint portion</p> <p>Open cell foam dam</p> <p>Double-faced adhesive tape</p> <p>Glass</p> <p>8 (0.31) or 15 (0.59)</p>	<p>Body side Install molding fastener. When installing it, heat body panel and fastener to approx. 30 to 40°C (86 to 104°F). Upper & side molding fasteners</p>  <p>Fastener</p> <p>Panel</p> <p>Double-faced adhesive tape</p>
<p>Apply urethane adhesive evenly. Windshield and rear window</p>  <p>7 - 8 (0.28 - 0.31)</p> <p>12 - 15 (0.47 - 0.59)</p> <p>Open cell foam dam</p> <p>Glass</p> <p>Unit: mm (in)</p>	<p>SBT823</p>

Repairing Water Leaks for Windshield

NFBT0023S0301

Leaks can be repaired without removing and reinstalling glass. If water is leaking between the urethane adhesive material and body or glass, determine the extent of leakage. This can be done by applying water to the windshield area while pushing glass outward.

To stop the leak, apply primer (if necessary) and then urethane adhesive to the leak point.

Removal and Installation

NFBT0024

CAUTION:

Be careful not to scratch door rearview mirror body.

★ For Wiring Diagram, refer to EL-183, "DOOR MIRROR" for details.

1. Remove door trim. Refer to "DOOR TRIM" for details, BT-35.
2. Remove inner cover front corner of door.
3. Disconnect door mirror harness connector.
4. Remove door mirror harness clips.
5. Remove bolts securing door mirror assembly.
6. Remove the mirror glass. Do not insert screwdriver too far.

GI

MA

EM

LC

EC

FE

CL

MT

AT

AX

SU

BR

ST

RS

BT

HA

SC

EL

IDX

SEC. 963

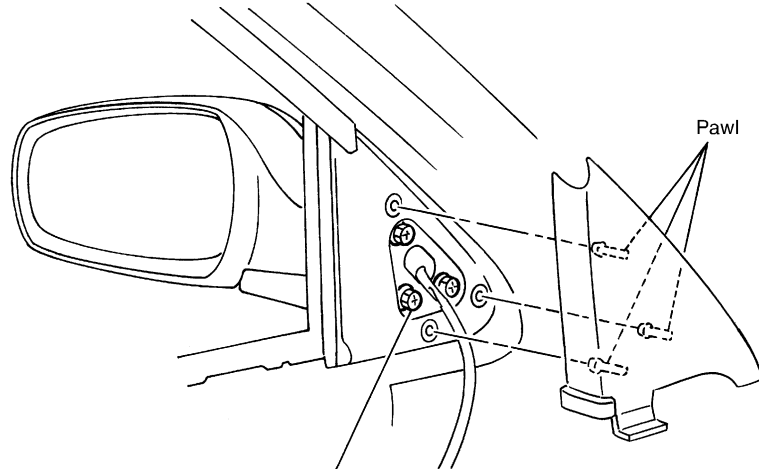

2.9 - 4.1 N•m (0.30 - 0.42 kg-m, 26.0 - 36.5 in-lb)

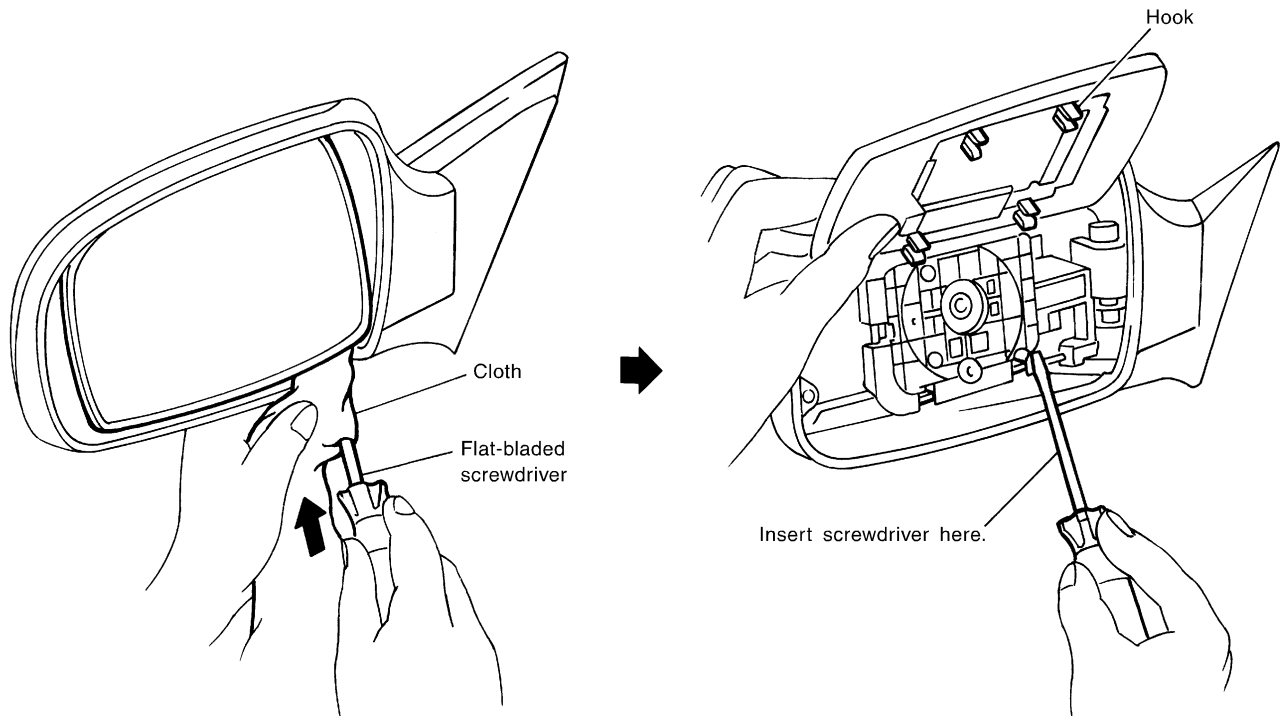

SBT813

REAR VIEW MIRROR

Removal and Installation

Removal and Installation

NFBT0025

REMOVAL

NFBT0025S01

Remove rearview mirror by pushing deflect spring with screwdriver as shown in the figure.

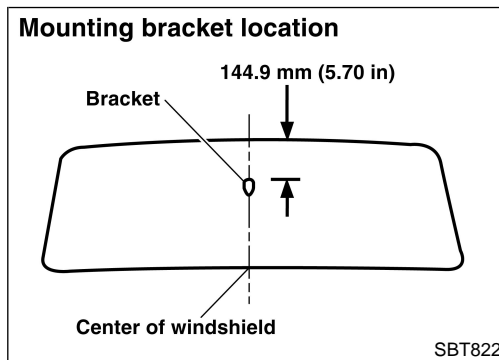
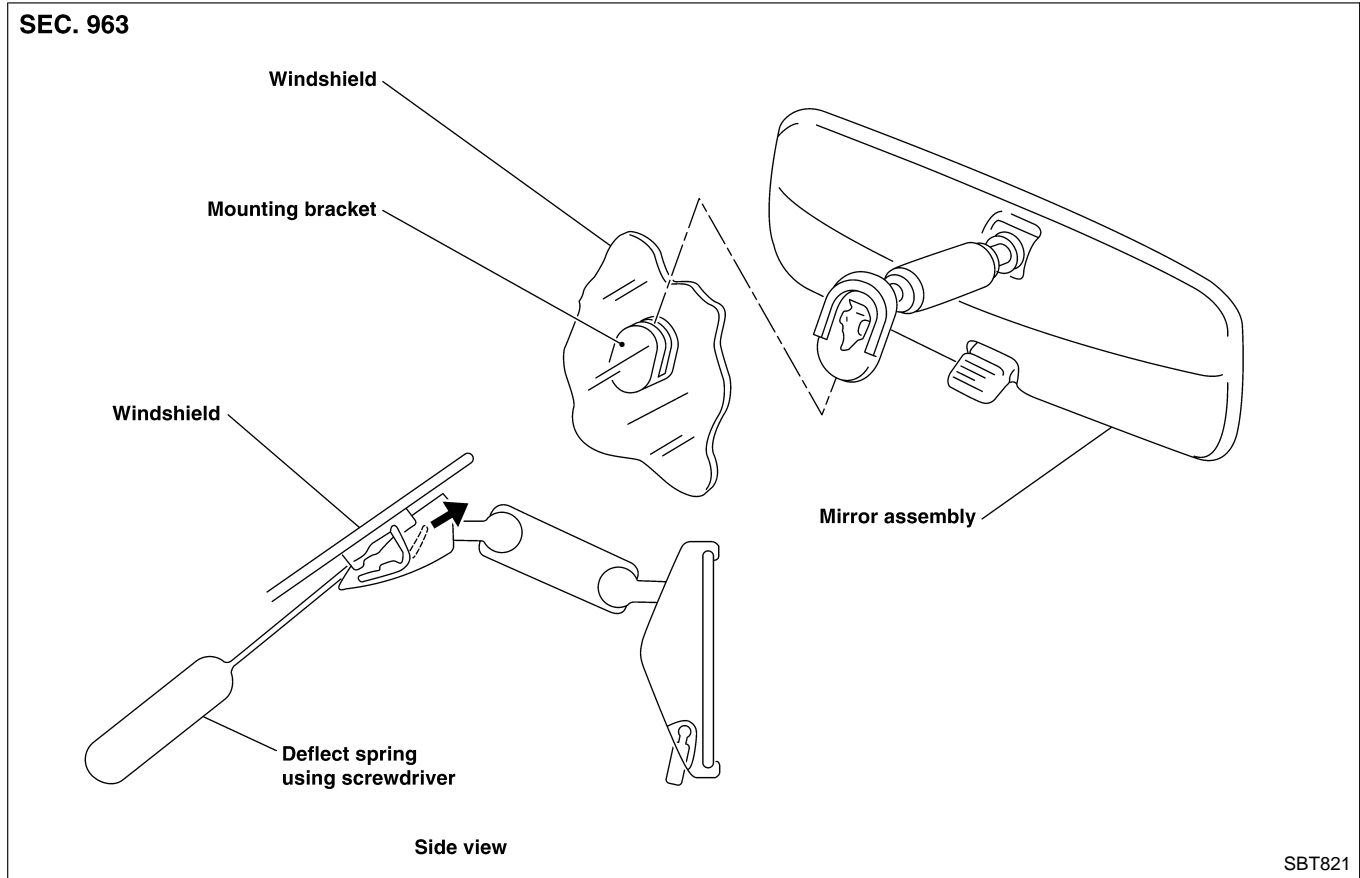

INSTALLATION

NFBT0025S02

1. Install mounting bracket as follows:
 - a. Determine mounting bracket position on windshield by measuring from top of windshield to top of mounting bracket as shown in the figure.
 - b. Mark location on outside of windshield with wax pencil or equivalent.
 - c. Clean attaching point on inside of windshield with an alcohol-saturated panel towel.
 - d. Sand bonding surface of mounting bracket with sandpaper (No. 320 or No. 360).
 - e. Clean bonding surface of mounting bracket with an alcohol-saturated paper towel.
 - f. Apply Loctite Adhesive 11067-2 or equivalent to bonding surface of mounting bracket.
 - g. Install mounting bracket at premarked position and press mounting bracket against glass for 30 to 60 seconds.
 - h. After five minutes, wipe off excess adhesive with an alcohol-moistened paper towel.
2. Install rearview mirror.

BODY (ALIGNMENT)

Alignment

Alignment

NFBT0026

- All dimensions indicated in figures are actual ones.
- When using a tracking gauge, adjust both pointers to equal length. Then check the pointers and gauge itself to make sure there is no free play.
- When a measuring tape is used, check to be sure there is no elongation, twisting or bending.
- Measurements should be taken at the center of the mounting holes.
- An asterisk (*) following the value at the measuring point indicates that the measuring point on the other side is symmetrically the same value.
- The coordinates of the measurement points are the distances measured from the standard line of "X", "Y" and "Z".

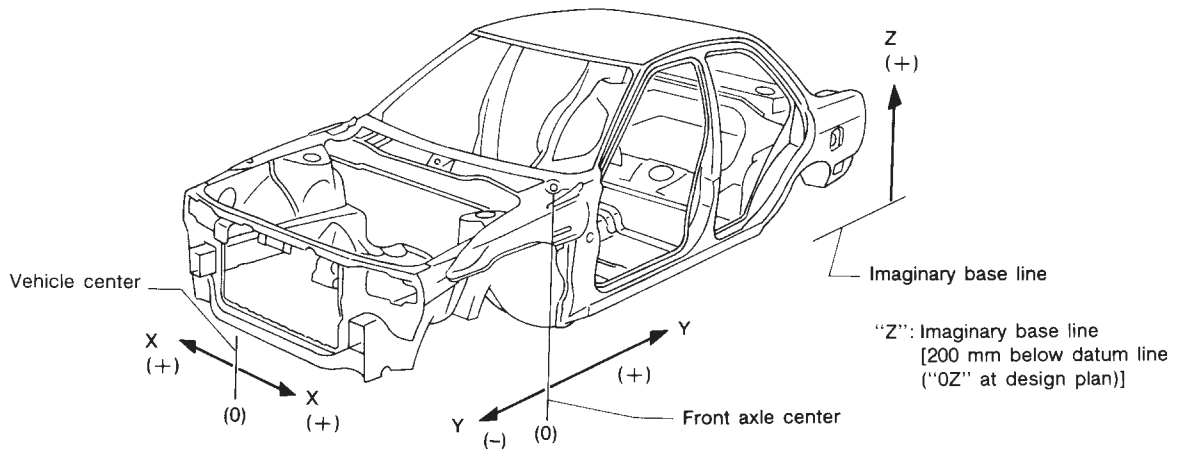

GI

MA

EM

LC

EC

FE

CL

MT

AT

AX

SBF874GB

SU

BR

ST

RS

BT

HA

SC

EL

IDX

BODY (ALIGNMENT)

Alignment (Cont'd)

ENGINE COMPARTMENT Measurement

NFBT0026S01

NFBT0026S0101

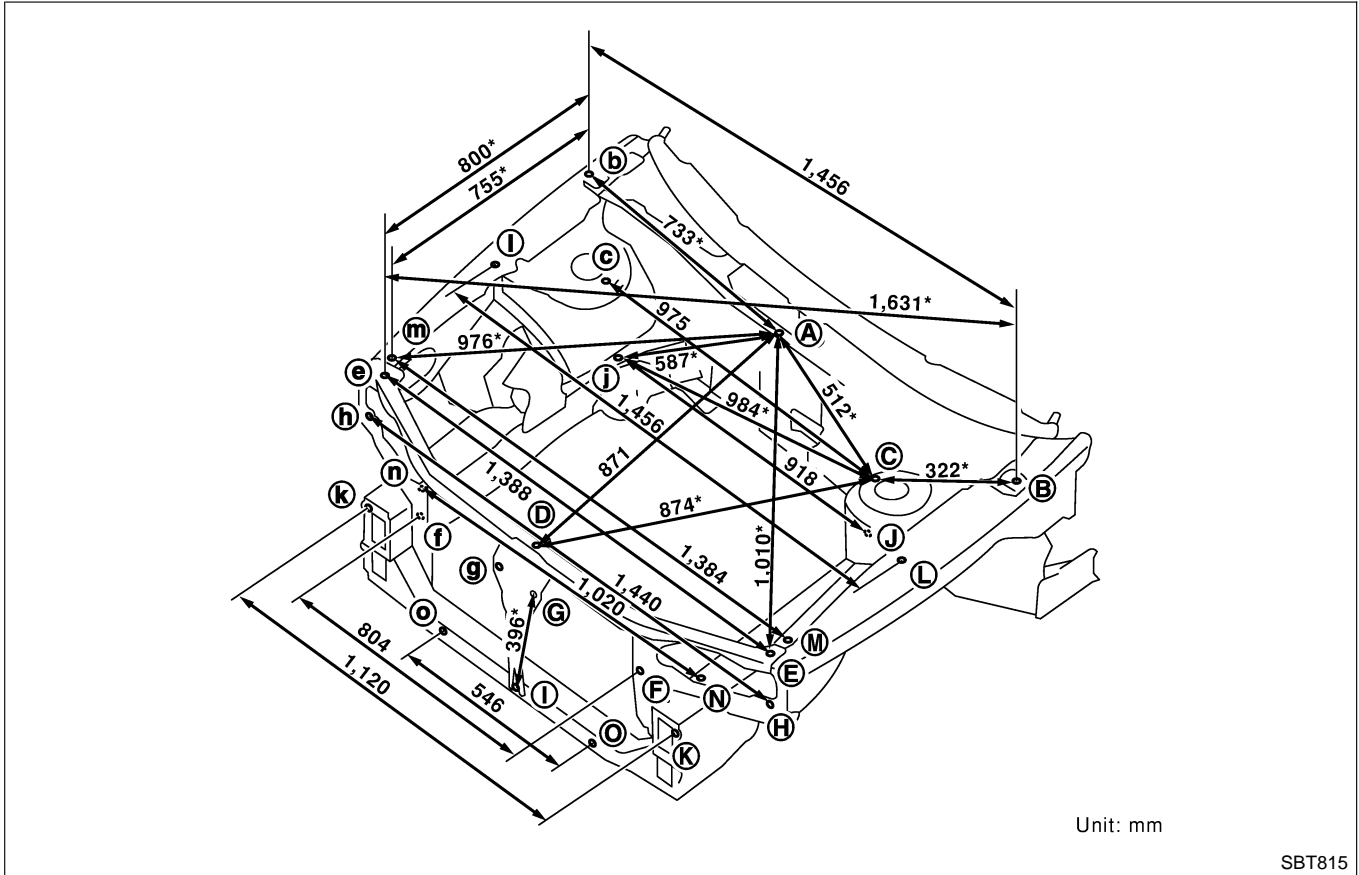

SBT815

BODY (ALIGNMENT)

Alignment (Cont'd)

Measurement Points

NFBT0026S0102

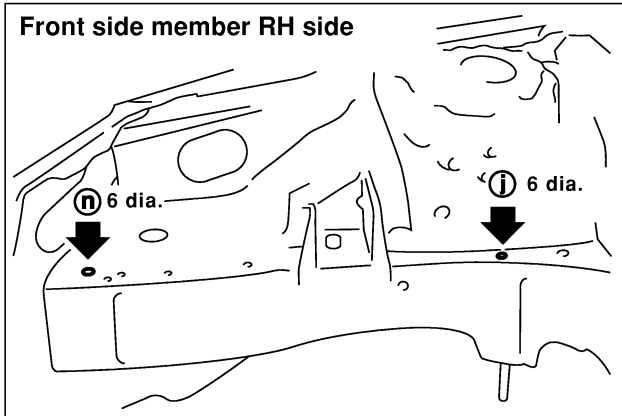
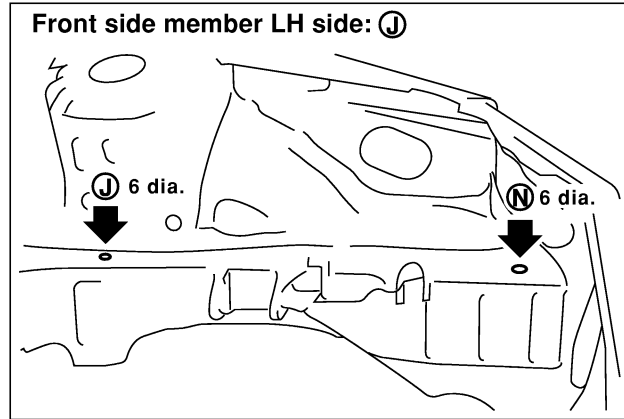
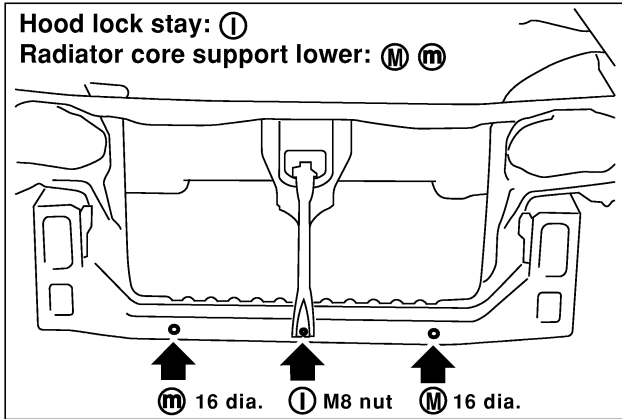
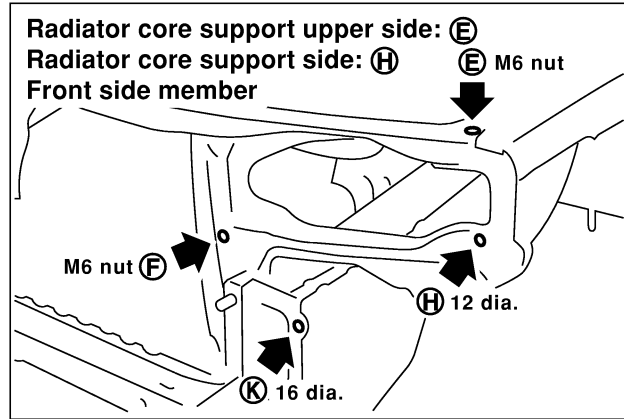
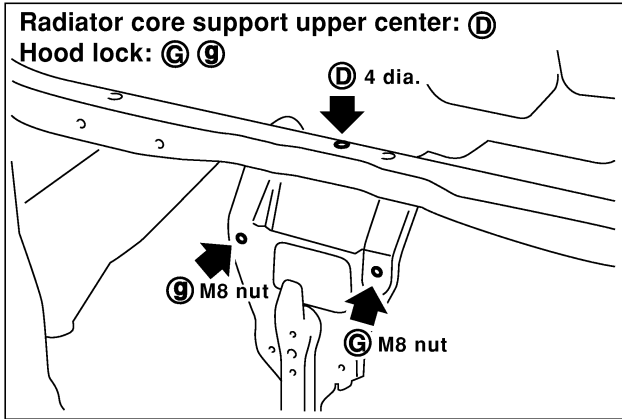
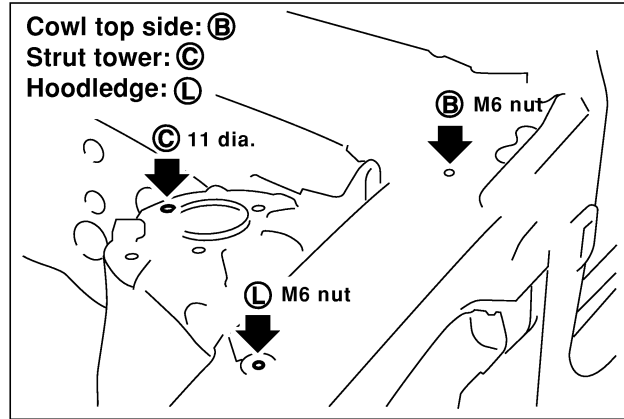
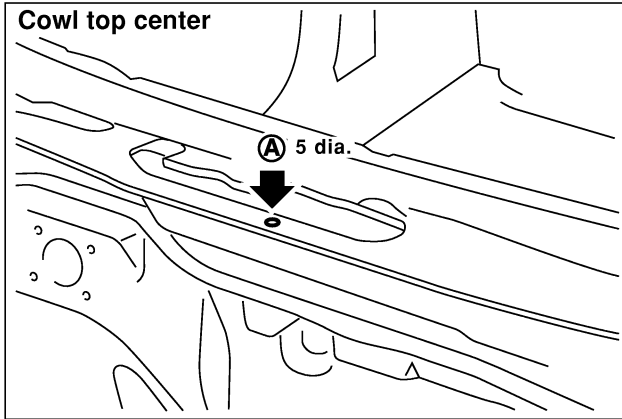

GI
 MA
 EM
 LC
 EC
 FE
 CL
 MT
 AT
 AX
 SU
 BR
 ST
 RS
 BT
 HA
 SC
 EL
 IDX

SBT816

BODY (ALIGNMENT)

Alignment (Cont'd)

UNDERBODY Measurement

NFBT0026S02

NFBT0026S0201

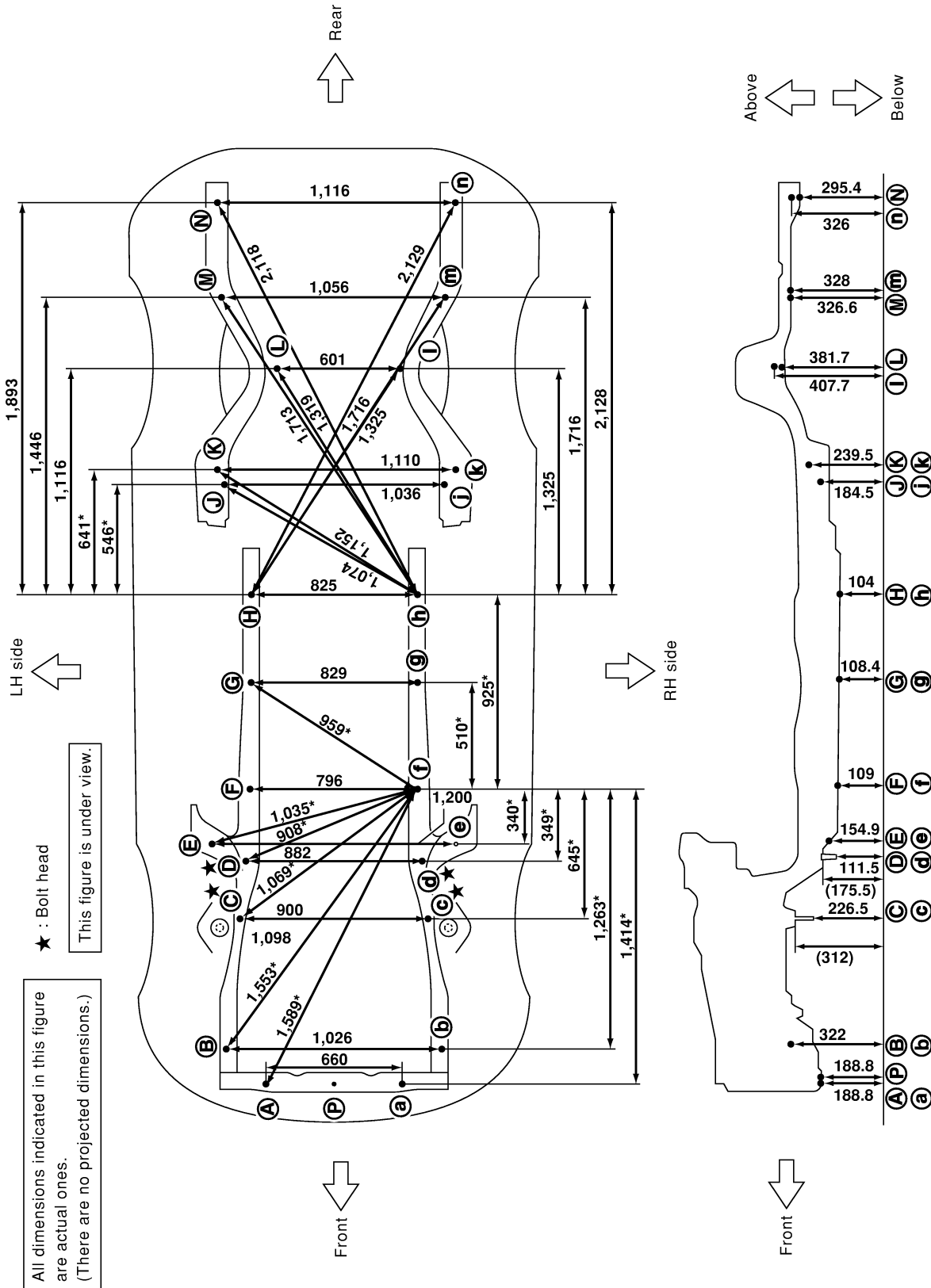

BODY (ALIGNMENT)

Alignment (Cont'd)

Measurement Points

NFBT0026S0202

GI
MA
EM
LC
EC
FE
CL
MT
AT
AX
SU
BR
ST
RS
BT
HA
SC
EL
IDX

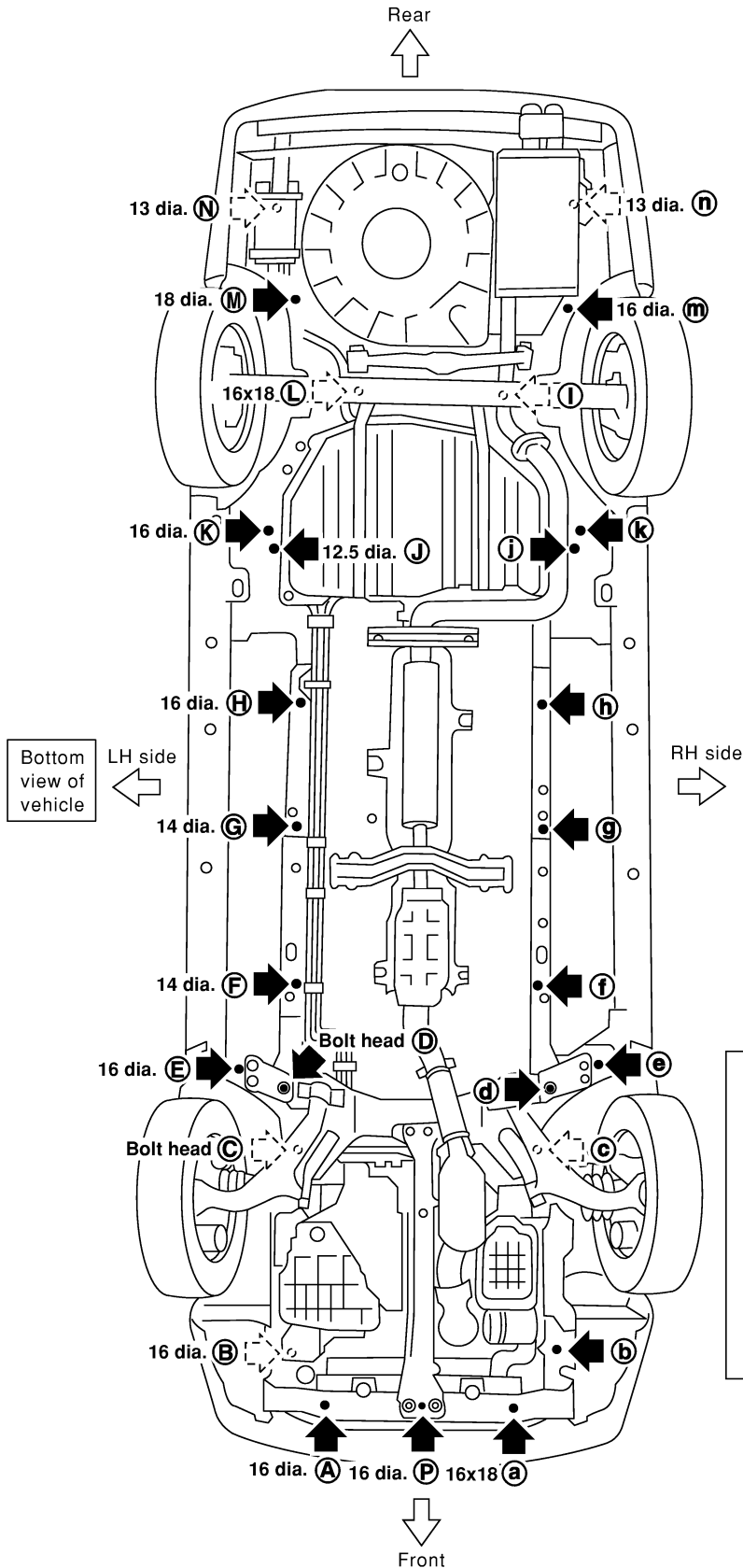

Coordinates

(A), (a)	(K), (k)
X : 330	X : 555
Y : -710	Y : 2,235
Z : 188.8	Z : 239.5
(B), (b)	(L)
X : 513	X : 300
Y : -540	Y : 2,700
Z : 322	Z : 381.7
(C), (c)	(I)
X : 450	X : -300
Y : 68	Y : 2,700
Z : 226.5	Z : 407.7
(D), (d)	(M)
X : 441	X : 512
Y : 354	Y : 3,050
Z : 111.5	Z : 326.6
(E), (e)	(m)
X : 600	X : -544
Y : 430	Y : 3,032
Z : 154.9	Z : 328.2
(F), (f)	(N)
X : 398	X : 546
Y : 700	Y : 3,504
Z : 109	Z : 295.4
(G), (g)	(n)
X : 414	X : -570.5
Y : 1,210	Y : 3,500
Z : 108.4	Z : 326.6
(H), (h)	(P)
X : 412.5	X : 0
Y : 1,625	Y : -700.5
Z : 104	Z : 188.8
(J), (j)	
X : 518.2	
Y : 2,155	
Z : 184.5	

Front and rear strut tower centers

Coordinates:

(Q), (q)
X : 548.8
Y : 28.7
Z : 779.3

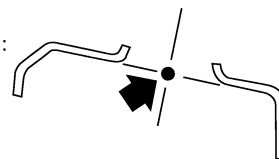

(Q), (q) Front: **(Q), (q)** 87 dia.
Rear: **(Q), (q)** 61.4 dia.

Unit: mm

NOTES