

SECTION **CL**

GI
MA
EM
LC
EF &
EC
FE
CL
MT
AT
FA
RA
BR
ST
BF
HA
EL
IDX

CONTENTS

| | | | |
|---|---|--|----|
| PRECAUTIONS AND PREPARATION | 2 | CLUTCH RELEASE MECHANISM | 7 |
| Precautions | 2 | CLUTCH DISC AND CLUTCH COVER | 8 |
| Special Service Tools | 2 | Clutch Disc | 8 |
| CLUTCH SYSTEM — Hydraulic Type | 3 | Clutch Cover and Flywheel | 9 |
| INSPECTION AND ADJUSTMENT | 4 | SERVICE DATA AND SPECIFICATIONS (SDS) | 10 |
| Adjusting Clutch Pedal | 4 | General Specifications | 10 |
| Bleeding Procedure | 4 | Inspection and Adjustment | 10 |
| HYDRAULIC CLUTCH CONTROL | 5 | | |
| Clutch Master Cylinder | 5 | | |
| Operating Cylinder | 6 | | |

PRECAUTIONS AND PREPARATION

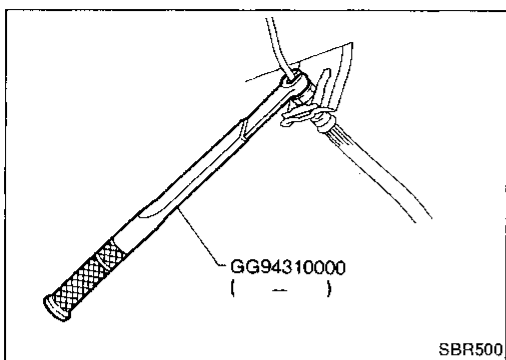

Precautions

- Recommended fluid is brake fluid "DOT 3".
- Never reuse drained brake fluid.
- Be careful not to splash brake fluid on painted areas.
- When removing and installing clutch piping, use Tool.
- Use new brake fluid to clean or wash all parts of master cylinder, operating cylinder and clutch damper.
- Never use mineral oils such as gasoline or kerosene. It will ruin the rubber parts of the hydraulic system.

WARNING:

After cleaning clutch disc, wipe it with a dust collector. Do not use compressed air.

Special Service Tools

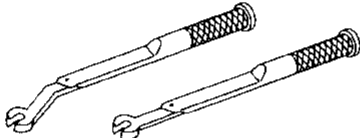
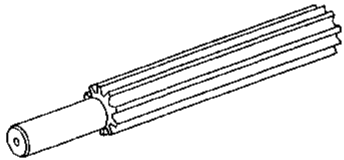
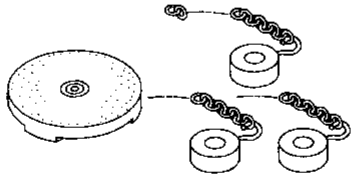
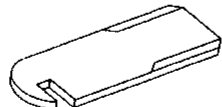
| Tool number (Kent-Moore No.) Tool name | Description | |
|--|--|--|
| GG94310000 (—) Flare nut torque wrench |  NT064 | Removing and installing clutch piping |
| KV30101000 (J33213) Clutch aligning bar |  NT061 | Installing clutch cover and clutch disc |
| ST20050010 (—) Base plate ST20050100 (—) Distance piece |  NT058 | Inspecting diaphragm spring of clutch cover |
| ST20050240 (—) Diaphragm spring adjusting wrench |  NT060 | Adjusting unevenness of diaphragm spring of clutch cover |

CLUTCH SYSTEM — Hydraulic Type

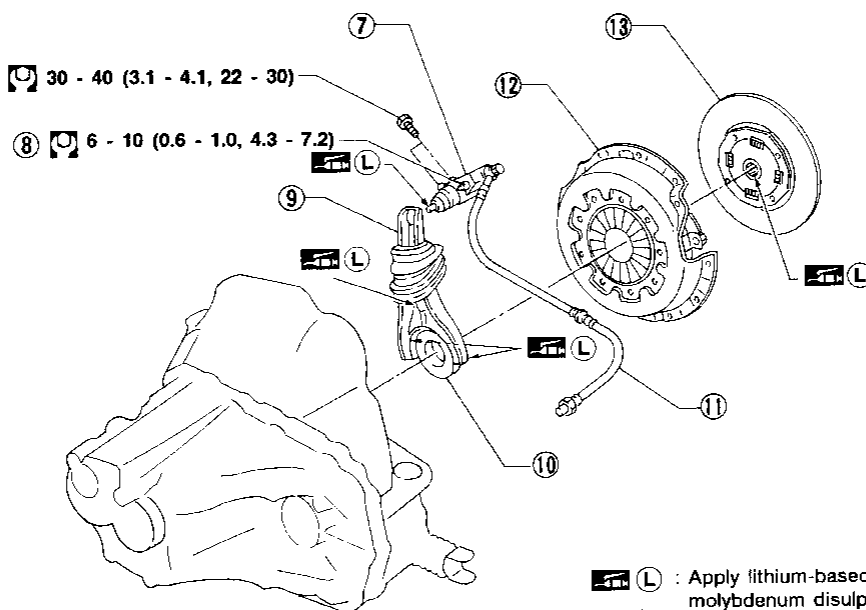
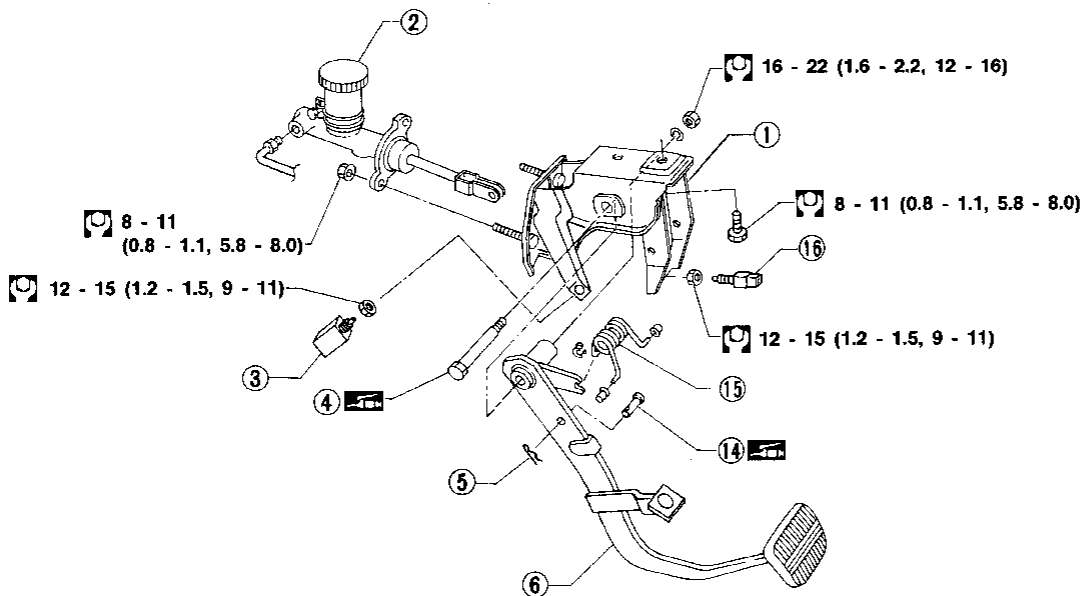

L : Apply lithium-based grease including molybdenum disulphide.
 : N·m (kg-m, ft-lb)

- ① Pedal bracket
- ② Clutch master cylinder
- ③ Clutch interlock switch
- ④ Fulcrum pin
- ⑤ Pin
- ⑥ Clutch pedal

- ⑦ Operating cylinder
- ⑧ Air bleeder screw
- ⑨ Withdrawal lever
- ⑩ Release bearing
- ⑪ Clutch hose

- ⑫ Clutch cover
- ⑬ Clutch disc
- ⑭ Clevis pin
- ⑮ Assist spring
- ⑯ ASCD cancel switch

GI
 MA
 EM
 LC
 EF &
 EC
 FE
CL
 MT
 AT
 FA
 RA
 BR
 ST
 BF
 HA
 EL
 IDX

SCL442

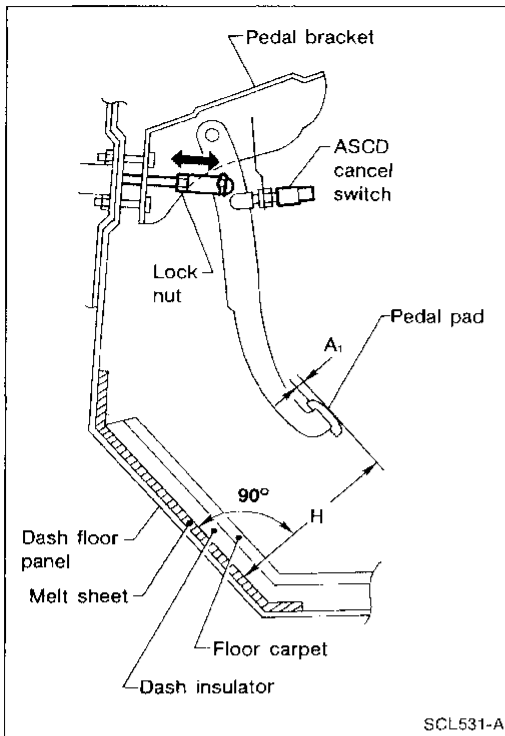

Adjusting Clutch Pedal

1. Adjust pedal height with ASCD cancel switch.
Pedal height "H":
 165 - 175 mm (6.50 - 6.89 in)
 2. Adjust pedal free play with master cylinder push rod. Then tighten lock nut.
Pedal free play "A₁":
 1.0 - 3.0 mm (0.039 - 0.118 in)
- Pedal free play means the following total, measured at position of pedal pad:**
- Play due to clevis pin and clevis pin hole in clutch pedal.

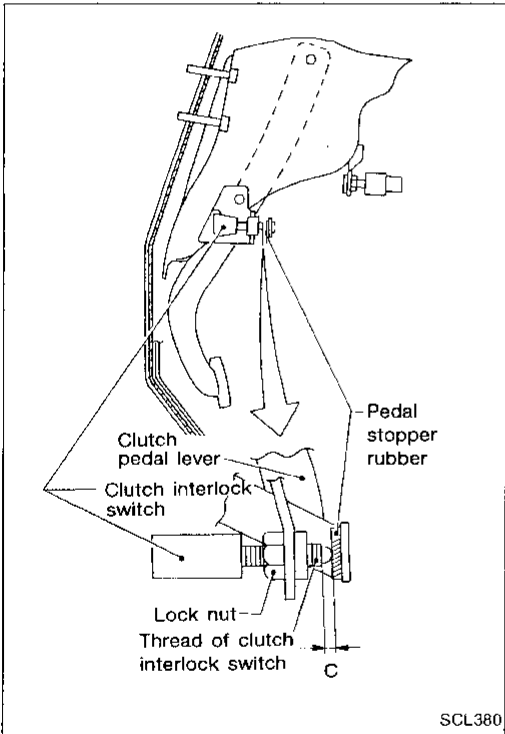

For U.S.A. model only

3. Adjust clearance "C" between pedal stopper rubber and threaded end of clutch interlock switch while depressing clutch pedal fully.
Clearance C:
 0.1 - 1.0 mm (0.004 - 0.039 in)

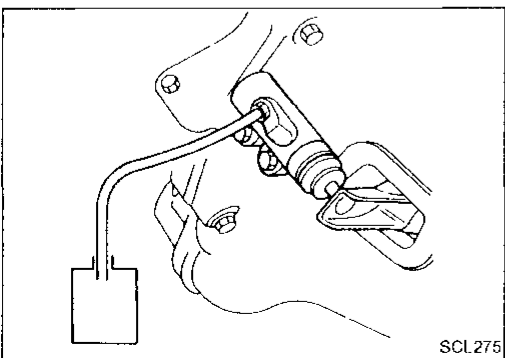

Bleeding Procedure

Bleed air according to the following procedure.

- Carefully monitor fluid level at master cylinder during bleeding operation.
1. Top up reservoir with recommended brake fluid.
 2. Connect a transparent vinyl tube to air bleeder valve.
 3. Fully depress clutch pedal several times.
 4. With clutch pedal depressed, open bleeder valve to release air, and close bleeder valve.
 5. Repeat steps 3 through 5 above until clear brake fluid comes out of air bleeder valve.

Clutch Master Cylinder

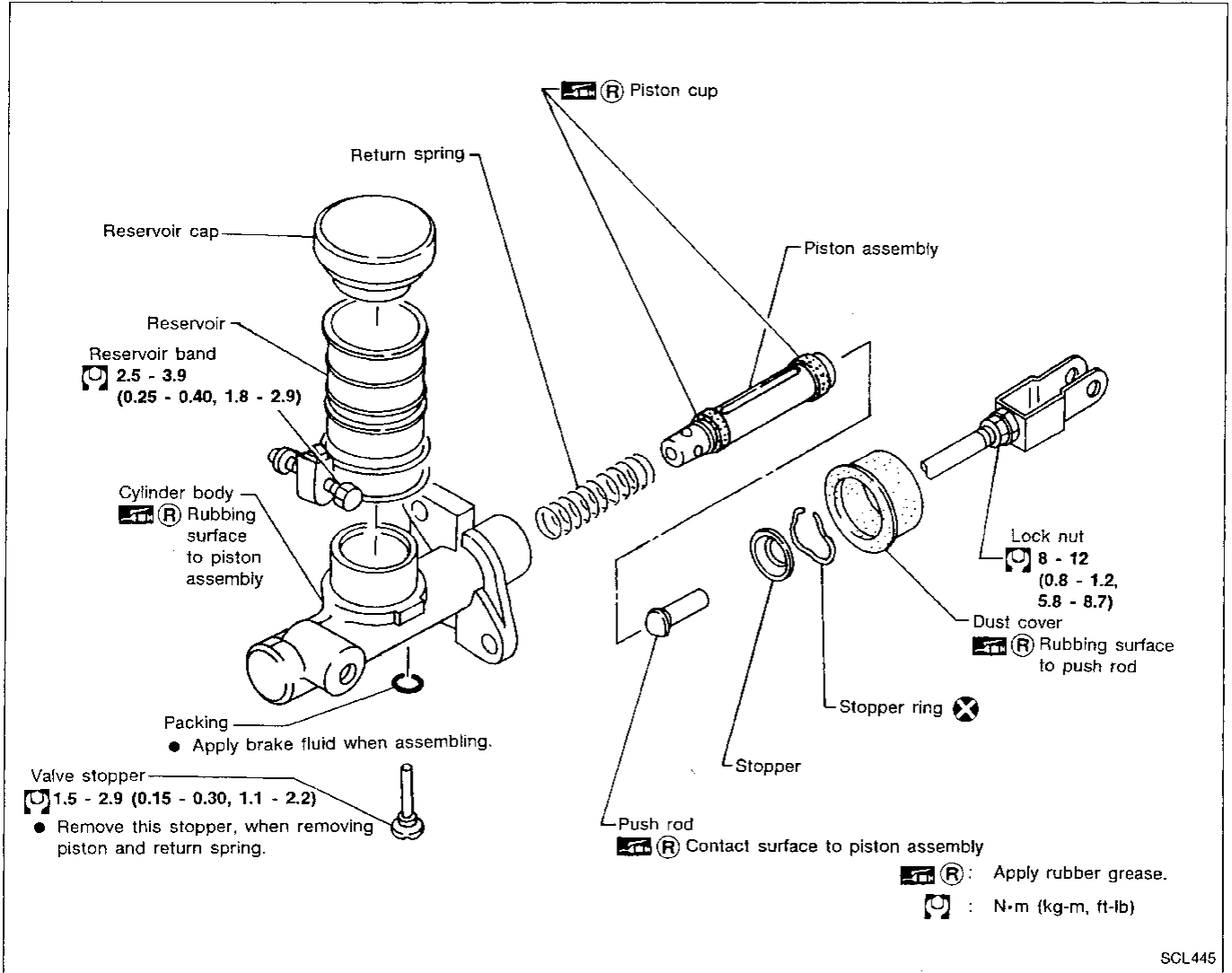

DISASSEMBLY AND ASSEMBLY

- Push piston into cylinder body with screwdriver when removing and installing valve stopper.

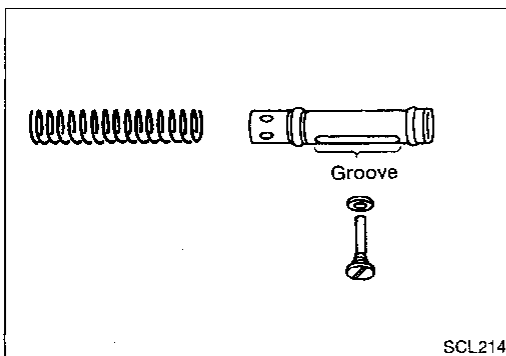

- Align groove of piston assembly and valve stopper when installing valve stopper.
- Check direction of piston cups.

GI
MA
EM
LC
EF & EC
FE
CL
MT
AT
FA
RA
BR
ST
BF
HA
EL
IDX

HYDRAULIC CLUTCH CONTROL

Clutch Master Cylinder (Cont'd)

INSPECTION

Check the following items, and replace if necessary.

- Rubbing surface of cylinder and piston, for uneven wear, rust or damage
- Piston with piston cup, for wear or damage
- Return spring, for wear or damage
- Dust cover, for cracks, deformation or damage
- Reservoir, for deformation or damage

Operating Cylinder

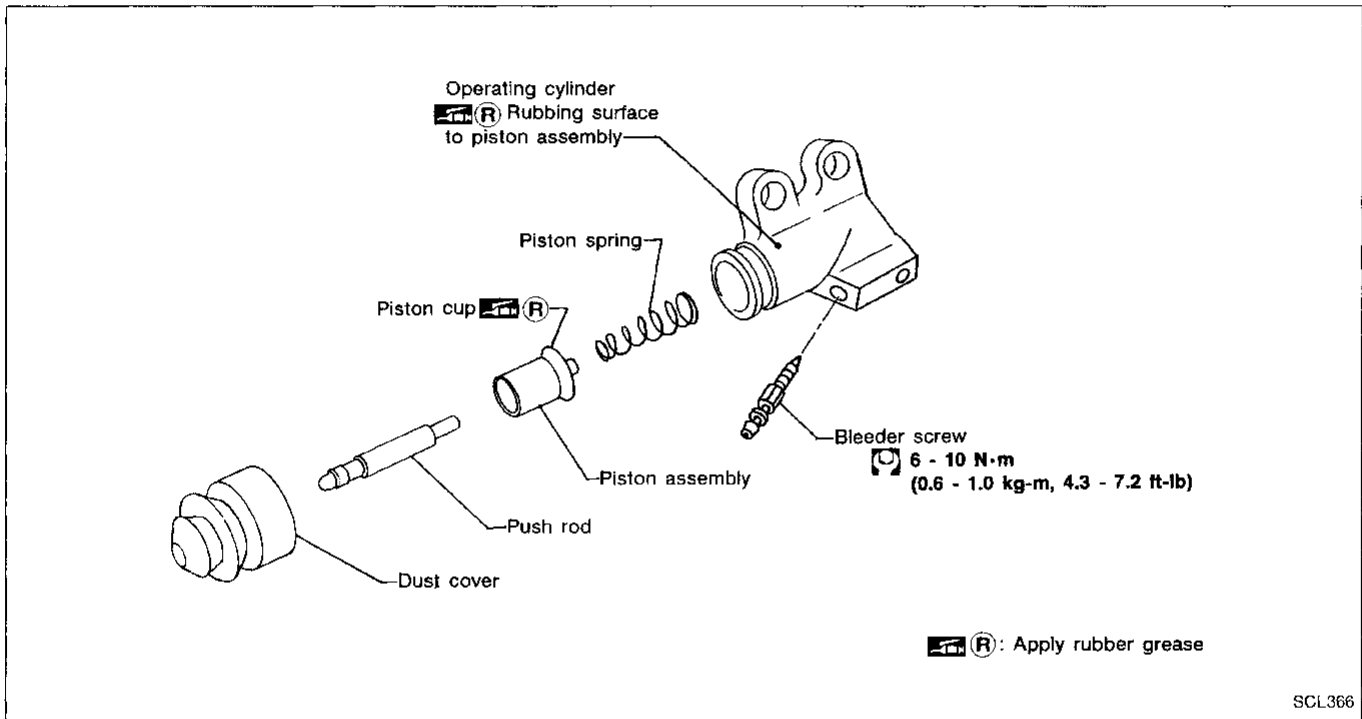

INSPECTION

Check the following items, and replace if necessary.

- Rubbing surface of cylinder and piston, for uneven wear, rust or damage
- Piston with piston cup, for wear or damage
- Piston spring, for wear or damage
- Dust cover, for cracks, deformation or damage

CLUTCH RELEASE MECHANISM

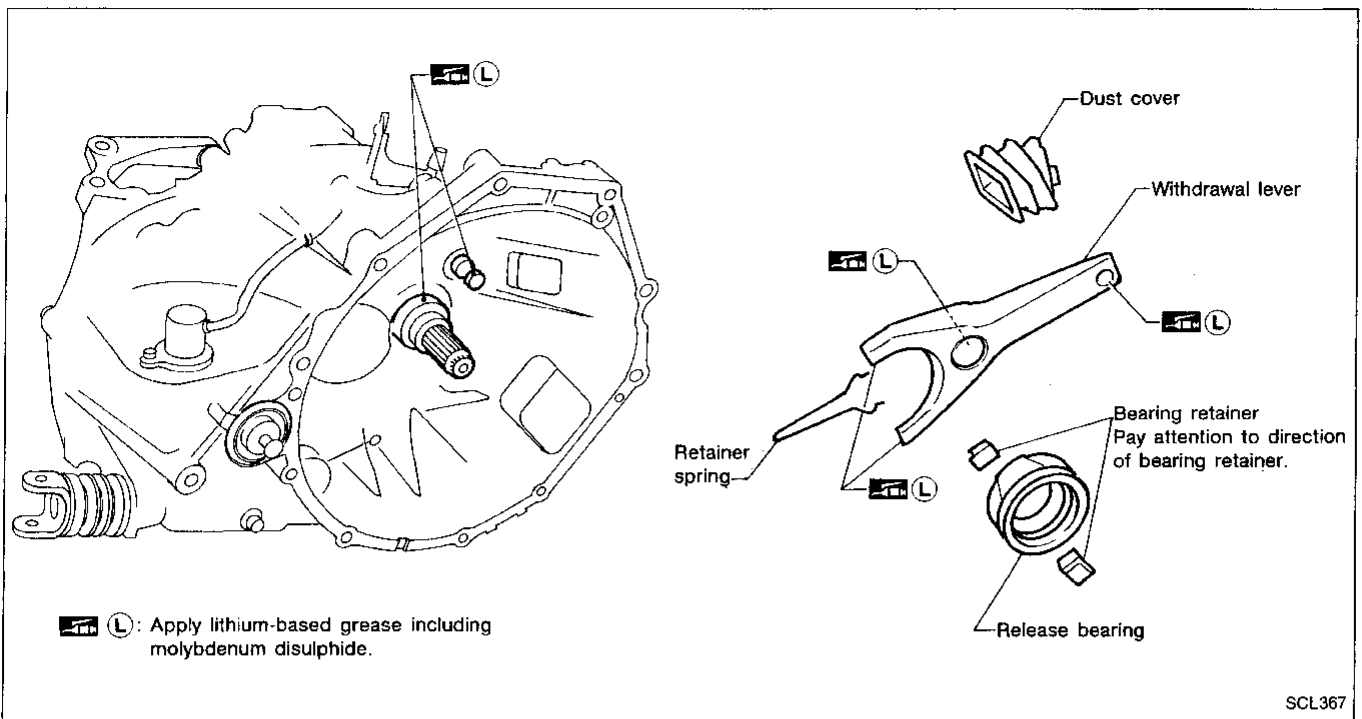

GI

MA

EM

LC

EF &
EC

FE

CL

INSPECTION

Check the following items, and replace if necessary.

- Release bearing, to see that it rolls freely and is free from noise, cracks, pitting or wear
- Release sleeve and withdrawal lever rubbing surface, for wear, rust or damage

MT

AT

FA

RA

BR

ST

BF

HA

EL

IDX

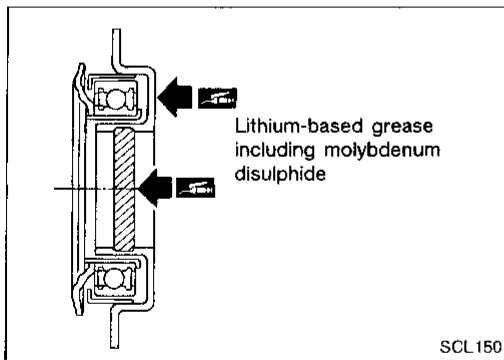

LUBRICATION

- Apply recommended grease to contact surface and rubbing surface.
- **Too much lubricant might damage clutch disc facing.**

CLUTCH DISC AND CLUTCH COVER

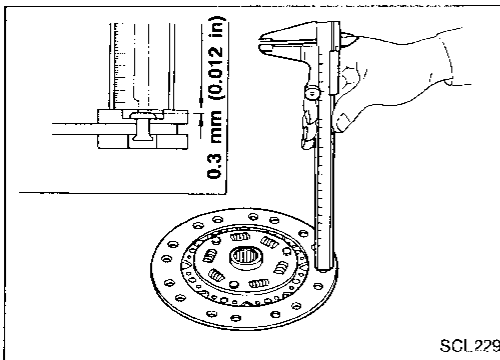
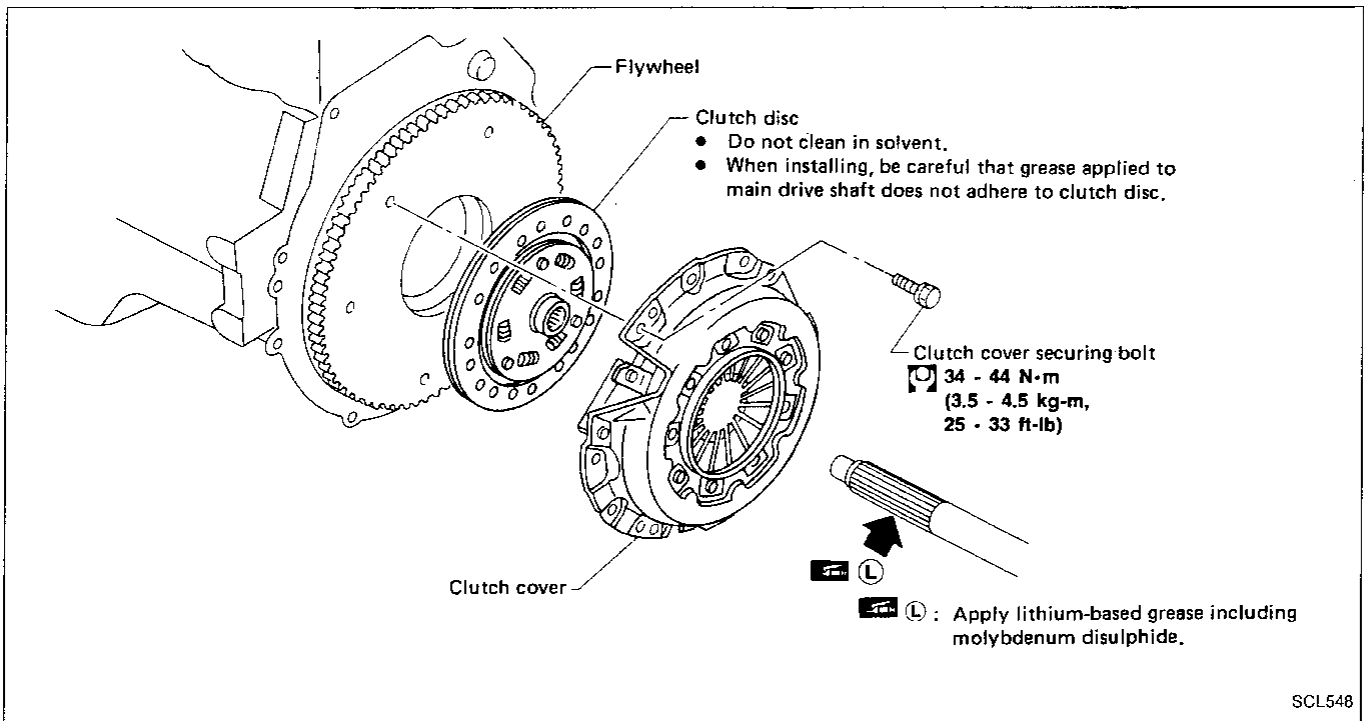

Clutch Disc

INSPECTION

Check the following items, and replace if necessary.

- Clutch disc, for burns, discoloration, oil or grease leakage
- Clutch disc, for wear of facing

Wear limit of facing surface to rivet head:
0.3 mm (0.012 in)

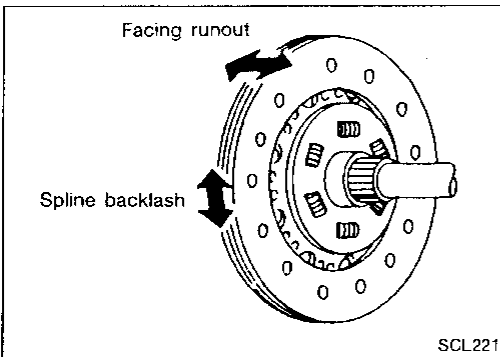

- Clutch disc, for spline backlash
Maximum spline backlash (at outer edge of disc):
1.0 mm (0.039 in)
- Clutch disc, for facing runout
Runout limit:
1.0 mm (0.039 in)
Distance of runout check point (from hub center)
115 mm (4.53 in)

INSTALLATION

- Apply recommended grease to contact surface of spline portion.
- Too much lubricant might damage clutch facing.**

CLUTCH DISC AND CLUTCH COVER

Clutch Cover and Flywheel

INSPECTION AND ADJUSTMENT

- Set Tool and check height and unevenness of diaphragm spring.

Diaphragm spring height "A":

37.5 - 39.5 mm (1.476 - 1.555 in)

- Check thrust rings for wear or damage by shaking cover assembly and listening for chattering noise, or lightly hammering on rivets for a slightly cracked noise. Replace clutch cover assembly if necessary.
- Check pressure plate and clutch disc contact surface for slight burns or discoloration. Repair pressure plate with emery paper.
- Check pressure plate and clutch disc contact surface for deformation or damage. Replace if necessary.

GI

MA

EM

LC

EF &
EC

FE

CL

MT

AT

FA

RA

BR

ST

BF

HA

EL

IDX

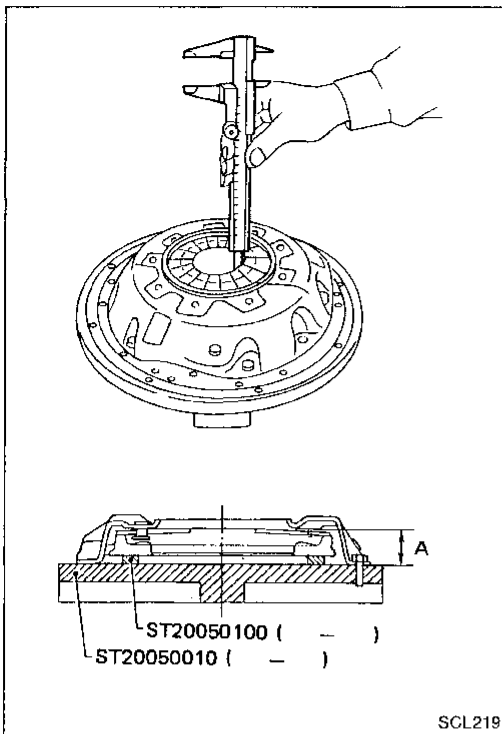

SCL219

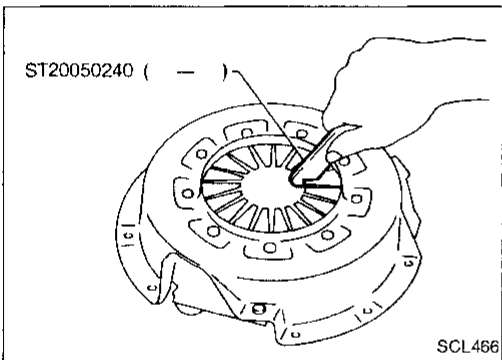

SCL466

- Adjust unevenness of diaphragm spring with Tool.

Uneven limit:

0.5 mm (0.020 in)

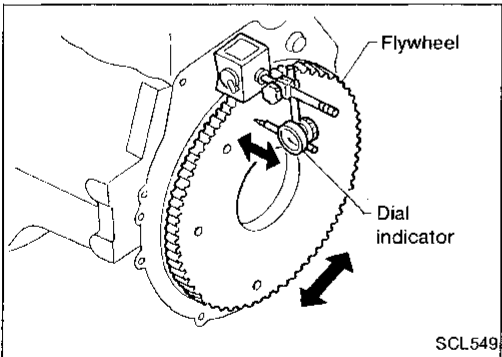

SCL549

FLYWHEEL INSPECTION

- Check contact surface of flywheel for slight burns or discoloration. Repair flywheel with emery paper.
- Check flywheel runout.

Runout (Total indicator reading):

Less than 0.15 mm (0.0059 in)

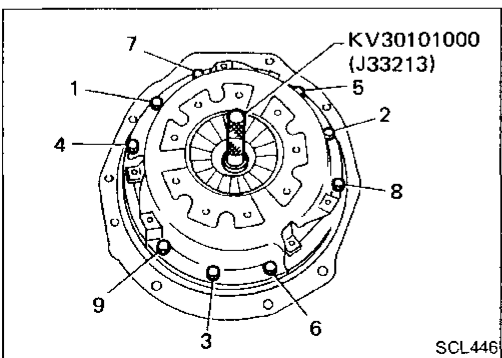

SCL446

INSTALLATION

- Insert Tool into clutch disc hub when installing clutch cover and disc.
- Tighten bolts in numerical order.
- **Be careful not to allow grease to contaminate clutch facing.**

SERVICE DATA AND SPECIFICATIONS (SDS)

General Specifications

CLUTCH CONTROL SYSTEM

| | |
|------------------------|-----------|
| Type of clutch control | Hydraulic |
|------------------------|-----------|

CLUTCH MASTER CYLINDER

| | | |
|----------------|---------|-------------|
| Inner diameter | mm (in) | 15.87 (5/8) |
|----------------|---------|-------------|

CLUTCH OPERATING CYLINDER

| | | |
|----------------|---------|-------------|
| Inner diameter | mm (in) | 19.05 (3/4) |
|----------------|---------|-------------|

CLUTCH PEDAL

Unit: mm (in)

| | |
|--|---------------------------|
| Pedal height* | 165 - 177 (6.50 - 6.97) |
| Pedal free play | 1.0 - 3.0 (0.039 - 0.118) |
| Clearance between pedal stopper rubber and clutch interlock switch threaded end while clutch pedal is fully depressed. | 0.1 - 1.0 (0.004 - 0.039) |

*: Measured from surface of melt sheet to pedal pad

CLUTCH DISC

Unit: mm (in)

| | |
|---|--|
| Model | 240 |
| Facing size (Outer dia. x inner dia. x thickness) | 240 x 160 x 3.5 (9.45 x 6.30 x 0.138) |
| Thickness of disc assembly | 7.6 - 8.0 (0.299 - 0.315) with 5,688 N (580 kg, 1,279 lb) |

CLUTCH COVER

| | |
|-----------|-------------------------------|
| Model | 240 |
| Full-load | N (kg, lb) 5,688 (580, 1,279) |

Inspection and Adjustment

CLUTCH DISC

Unit: mm (in)

| | |
|--|-------------|
| Model | 240 |
| Wear limit of facing surface to rivet head | 0.3 (0.012) |
| Facing runout limit | 1.0 (0.039) |
| Distance of runout check point (from the hub center) | 115 (4.53) |
| Maximum spline backlash (at outer edge of disc) | 1.0 (0.039) |

CLUTCH COVER

Unit: mm (in)

| | |
|---|-----------------------------|
| Model | 240 |
| Diaphragm spring height | 37.5 - 39.5 (1.476 - 1.555) |
| Uneven limit of diaphragm spring toe height | 0.5 (0.020) |