

SECTION BF

GI
MA
EM
LC
EF & EC
FE
CL
MT
AT
FA
RA
BR
ST
BF
HA
EL
IDX

CONTENTS

GENERAL SERVICING	2	Power Supply Inspection (Equipped with digital touch entry system).....	71
Precautions.....	2	WINDSHIELD AND WINDOWS	72
Supplemental Restraint System "AIR BAG".....	2	Windshield and Rear Window.....	72
Circuit Breaker Inspection.....	2	MIRROR	74
Clip and Fastener.....	2	Door Mirror.....	74
BODY END	5	REAR COMBINATION LAMP AND REAR AIR SPOILER	75
Body Front End.....	5	Rear Combination Lamp.....	75
Body Rear End and Opener.....	7	Rear Air Spoiler.....	75
DOOR	10	BODY ALIGNMENT	76
Front Door.....	10	Engine Compartment.....	76
Rear Door.....	11	Underbody.....	78
Power Door Lock.....	12	SUPPLEMENTAL RESTRAINT SYSTEM (SRS)	80
Power Window.....	18	Precautions for SRS "Air Bag" Service.....	80
DOOR — Trouble Diagnoses for Power Window	20	Special Service Tool.....	80
Contents.....	20	Commercial Service Tools.....	80
INSTRUMENT PANEL	29	Description.....	81
INTERIOR AND EXTERIOR	31	SRS Component Parts Location and Caution Labels.....	82
Interior.....	31	Caution Labels.....	83
Exterior.....	35	Maintenance Items.....	85
SEAT	39	Removal and Installation — Diagnosis (Control) Unit and Sensors.....	86
Front Seat.....	39	Removal — Air Bag Module and Spiral Cable.....	86
Rear Seat.....	41	Installation — Air Bag Module and Spiral Cable.....	88
AUTOMATIC SEAT BELT SYSTEM	42	Scrapping the Air Bag.....	89
Unit Location.....	42	TROUBLE DIAGNOSES — Supplemental Restraint System (SRS)	91
Wiring Diagram.....	44	Contents.....	91
Description.....	46		
AUTOMATIC SEAT BELT SYSTEM — Trouble Diagnoses	48		
Contents.....	48		
SUN ROOF	69		
Wiring Diagram.....	71		

When you read wiring diagrams:

- Read GI section, "HOW TO READ WIRING DIAGRAMS".
- See EL section, "POWER SUPPLY ROUTING" for power distribution circuit.

When you perform trouble diagnoses, read GI section, "HOW TO FOLLOW FLOW CHART IN TROUBLE DIAGNOSES".

★ For conventional seat belt, refer to MA section.

Precautions

- When removing or installing various parts, place a cloth or padding onto the vehicle body to prevent scratches.
- Handle trim, molding, instruments, grille, etc. carefully during removing or installing. Be careful not to soil or damage them.
- Apply sealing compound where necessary when installing parts.
- When applying sealing compound, be careful that the sealing compound does not protrude from parts.
- When replacing any metal parts (for example body outer panel, members, etc.), be sure to take rust prevention measures.

Supplemental Restraint System "AIR BAG"

The Supplemental Restraint System "Air Bag" helps to reduce the risk or severity of injury to the driver in a frontal collision. The Supplemental Restraint System consists of an air bag (located in the center of the steering wheel), sensors, a diagnosis unit, warning lamp, wiring harness and spiral cable. Information necessary to service the system safely is included in the **BF** section of this Service Manual.

WARNING:

- To avoid rendering the SRS inoperative, which could lead to personal injury or death in the event of a severe frontal collision, all maintenance must be performed by an authorized NISSAN dealer.
- Improper maintenance, including incorrect removal and installation of the SRS, can lead to personal injury caused by unintentional activation of the system.
- All SRS electrical wiring harnesses and connectors are covered with yellow outer insulation. Do not use electrical test equipment on any circuit related to the SRS "Air Bag".

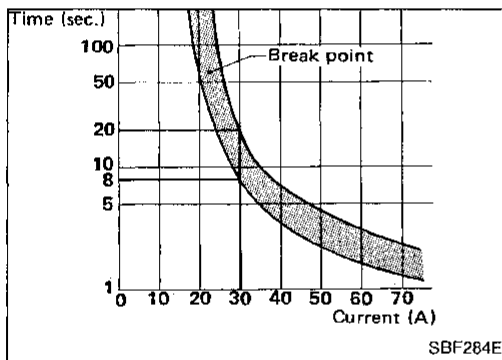

Circuit Breaker Inspection

For example, when current is 30A, the circuit is broken within 8 to 20 seconds.

Circuit breakers are used in the following systems.

- Trunk lid opener
- Power window & power door lock
- Power seat
- Automatic seat belt
- Power sun roof









Clip and Fastener

- Clips and fasteners in BF section correspond to the following numbers and symbols.
- Replace any clips and/or fasteners which are damaged during removal or installation.

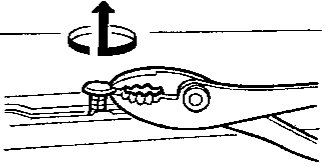
Symbol No.	Shapes	Removal & Installation
		<p>Removal: Remove by bending up with flat-bladed screwdrivers.</p>
	SBF256G	SBF367B

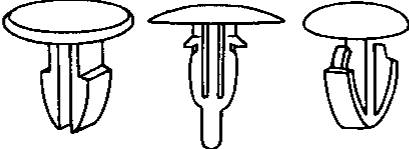
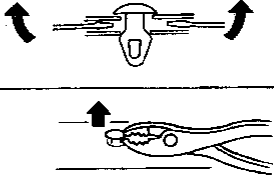
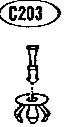
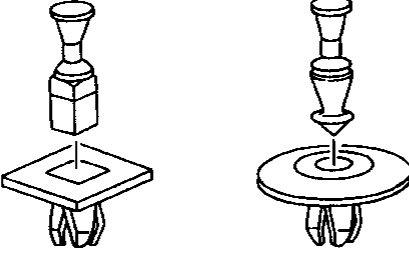
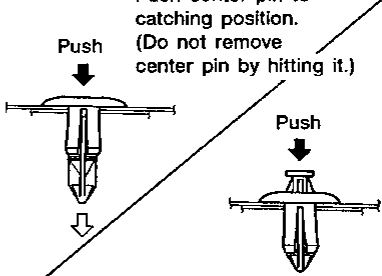
GENERAL SERVICING

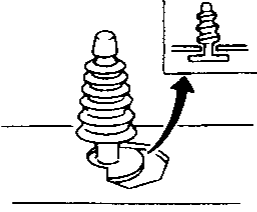
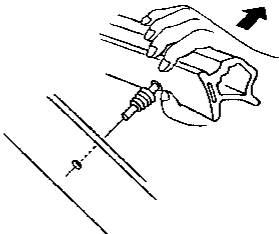
Clip and Fastener (Cont'd)

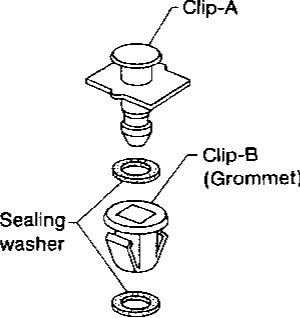
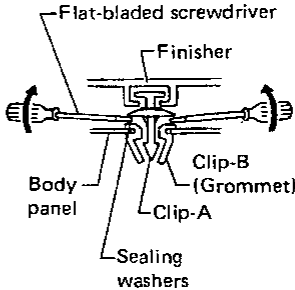
Symbol No.	Shapes	Removal & Installation
		 <p>Removal: Pull up by rotating.</p> <p style="text-align: right;">SBF115B</p>
		<p>Removal: Remove with a flat-bladed screwdriver or pliers.</p>  <p style="text-align: right;">SBF292C</p>
		<p>Push center pin to catching position. (Do not remove center pin by hitting it.)</p>  <p>Installation:</p> <p style="text-align: right;">SBF708E</p>
		<p>Removal:</p>  <p style="text-align: right;">SBF147B</p>
		<p>Removal:</p>  <p style="text-align: right;">SBF259G</p>

GI

MA

EM

LC

EF &
EC

FE

CL

MT

AT

FA

RA

BR

ST

BF









HA

EL

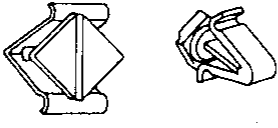
IDX

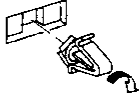
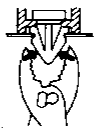
GENERAL SERVICING

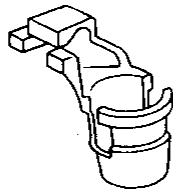
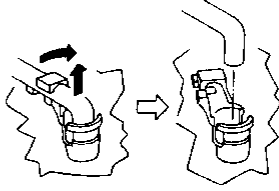
Clip and Fastener (Cont'd)

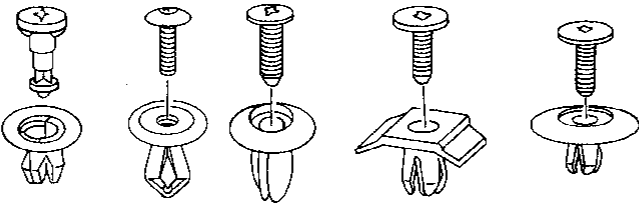
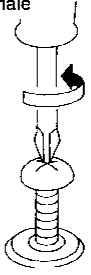
Symbol No.	Shapes	Removal & Installation
 		<p>Removal:</p>  <p>Rotate 45° to remove.</p> <hr/> <p>Installation:</p>  <p>Removal:</p>  <p>Installation:</p> 
		<p>Removal: Holder portion of clip must be spread out to remove rod.</p> 
		<p>Removal:</p> <ol style="list-style-type: none"> 1. Screw out with a Phillips screwdriver. 2. Remove female portion with flat-bladed screwdriver. 

SBF145B

SBF085B

SBF768B

SBF770B

SBF078B

SBF992G

BODY END

Body Front End

- When removing or installing hood or trunk lid, place a cloth or other padding on hood or trunk lid to avoid scratching vehicle body.
- Bumper fascia: It is made of plastic, so do not use excessive force and take care to keep oil away from it.
- Hood adjustment: Adjust at hinge portion.
- Hood lock adjustment: After adjusting, check hood lock control operation. Apply a coat of grease to hood locks engaging mechanism.
- Hood opener: Do not attempt to bend cable forcibly. Doing so increases effort required to unlock hood.

WARNING:

- Be careful not to scratch hood stay when installing hood. A scratched stay may cause gas leakage.
- The contents of the hood stay are under pressure. Do not take apart, puncture, apply heat or allow fire near it.

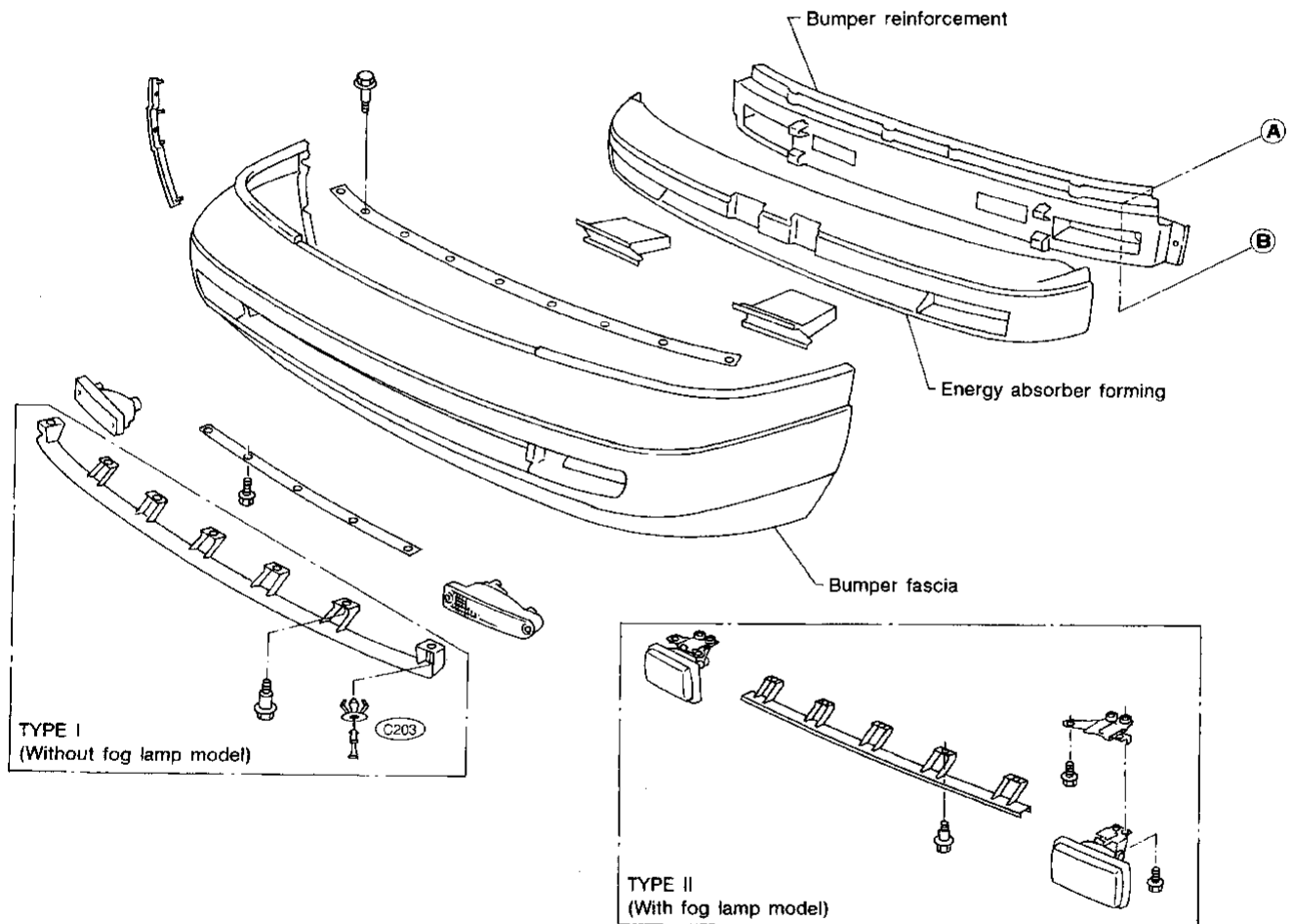

GI

MA

EM

LC

EF &
EC

FE

CL

MT

AT

FA

RA

BR

ST

BF

HA

EL

IDX

BODY END

Body Front End (Cont'd)

Hood lock adjustment

- Adjust hood so that hood primary lock meshes at a position 1 to 1.5 mm (0.039 to 0.059 in) lower than fender.
- After hood lock adjustment, adjust bumper rubber.
- When securing hood lock, ensure it does not tilt. Striker must be positioned at the center of hood primary lock.
- After adjustment, ensure that hood primary and secondary lock operate properly.

Hood lock secondary latch hooking length

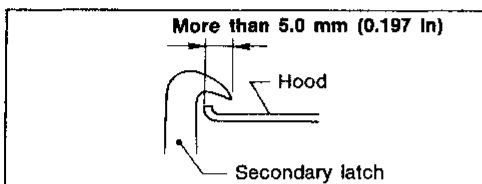

Bumper rubber adjustment

- Adjust so that hood is aligned with fender. At that time deflection is approx. 2 mm (0.08 in). [Bumper rubber free height is approx. 13 mm (0.51 in).]

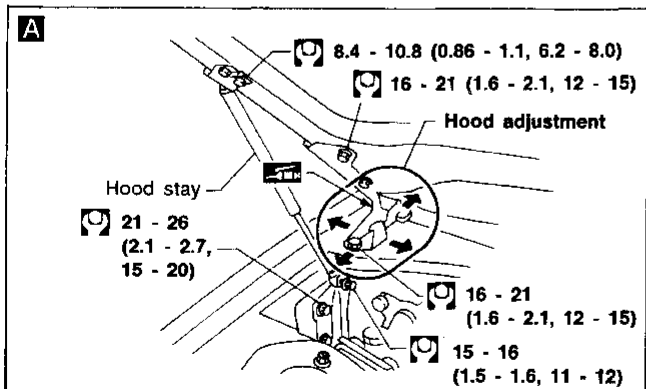
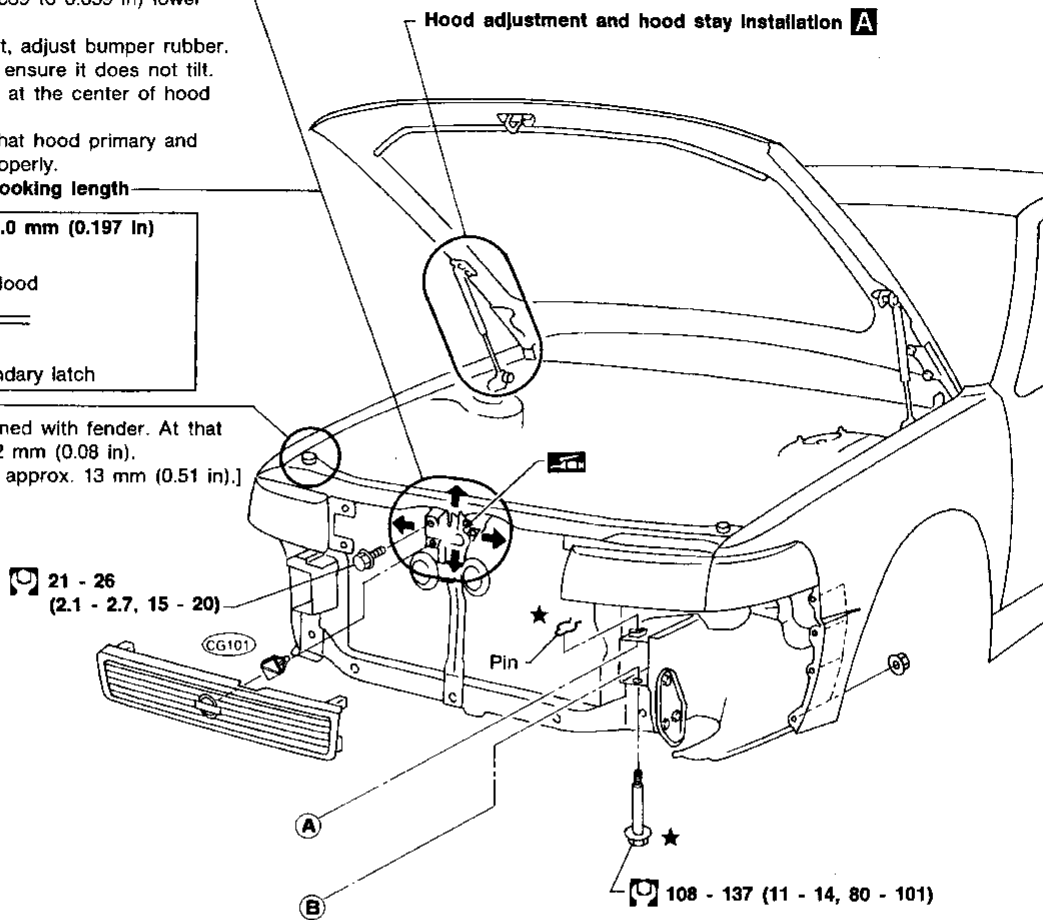

- ★ : Bumper assembly mounting bolts, nuts and clips
- ☐ : N·m (kg-m, ft-lb)

Body Rear End and Opener

- Trunk lid adjustment: Adjust at hinge-trunk lid portion for proper trunk lid fit.
- Trunk lid lock system adjustment: Adjust striker so that it is in the center of the lock. After adjustment, check trunk lid lock operation.
- Opener cable: Do not attempt to bend cable using excessive force.
- After installation, make sure that trunk lid and fuel filler lid open smoothly.

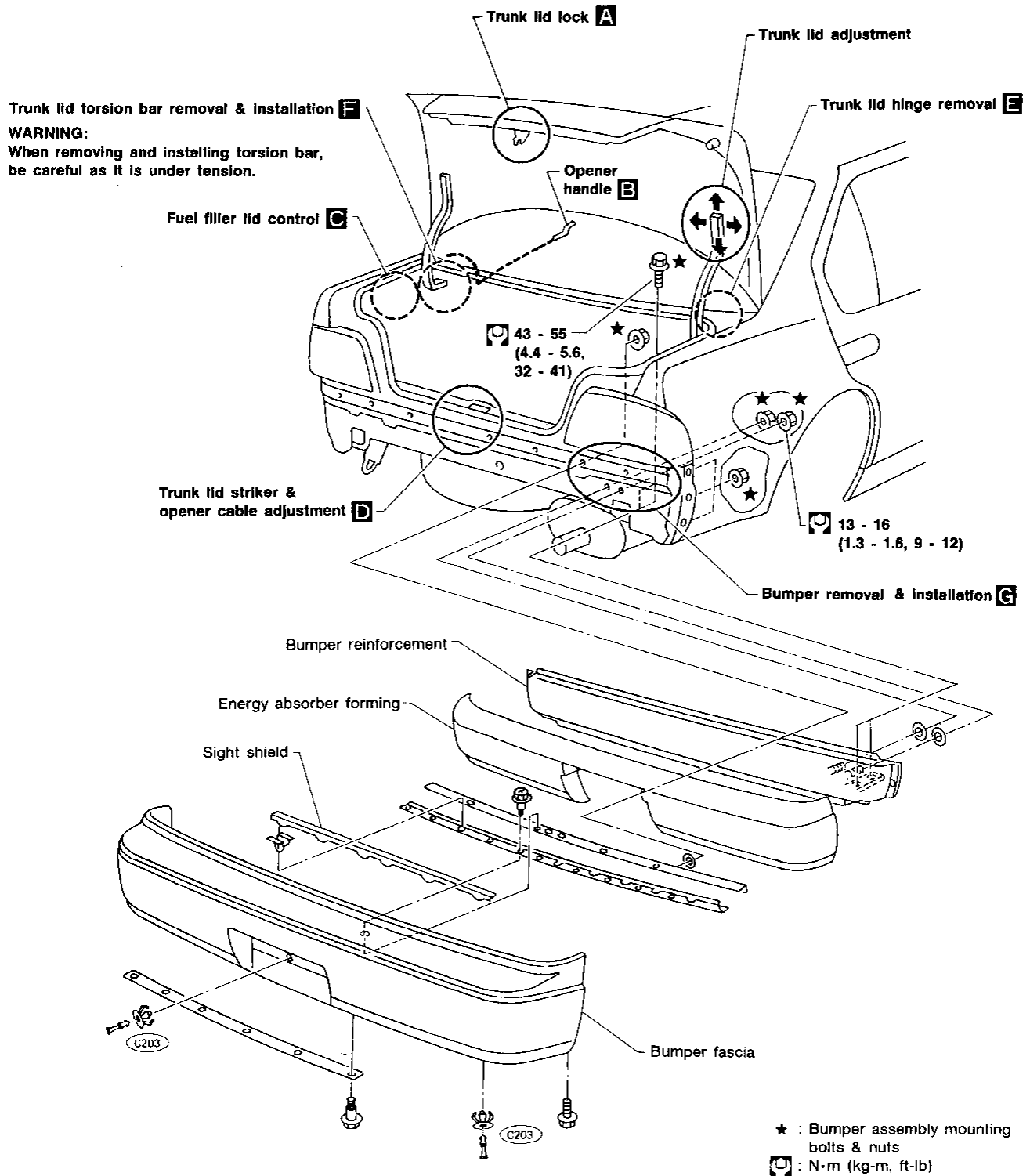

GI
MA
EM
LC
EF & EC
FE
CL
MT
AT
FA
RA
BR
ST
BF
HA
EL
IDX

BODY END

Body Rear End and Opener (Cont'd)

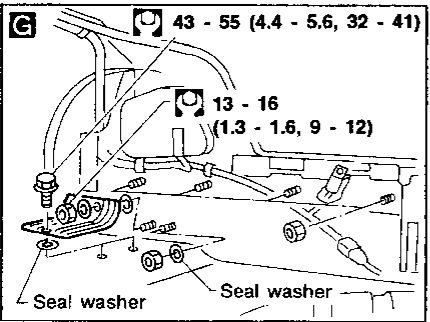
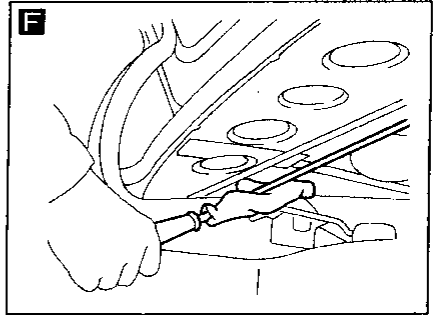
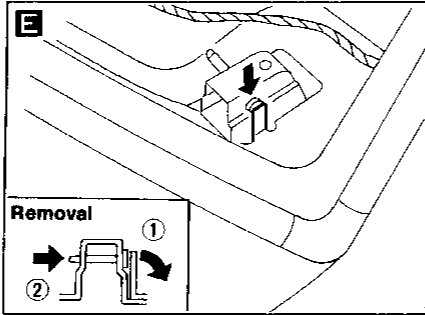
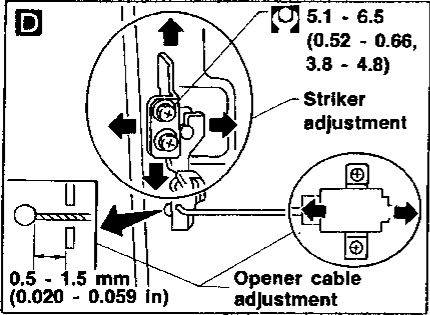
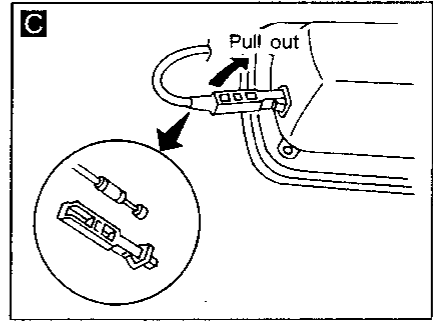
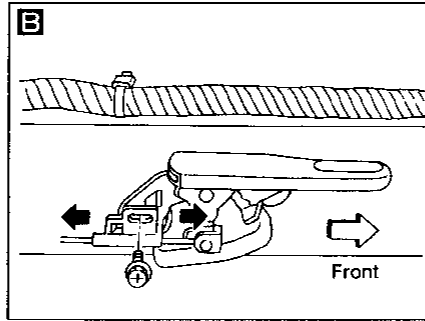
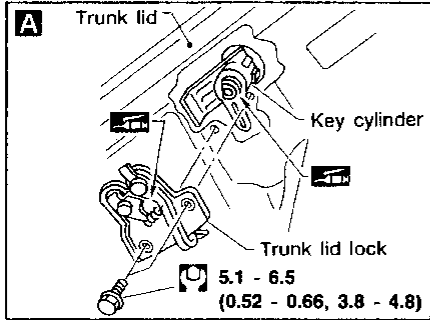

: N·m (kg-m, ft-lb)

BODY END

Body Rear End and Opener (Cont'd)

TRUNK LID OPENER/WIRING DIAGRAM

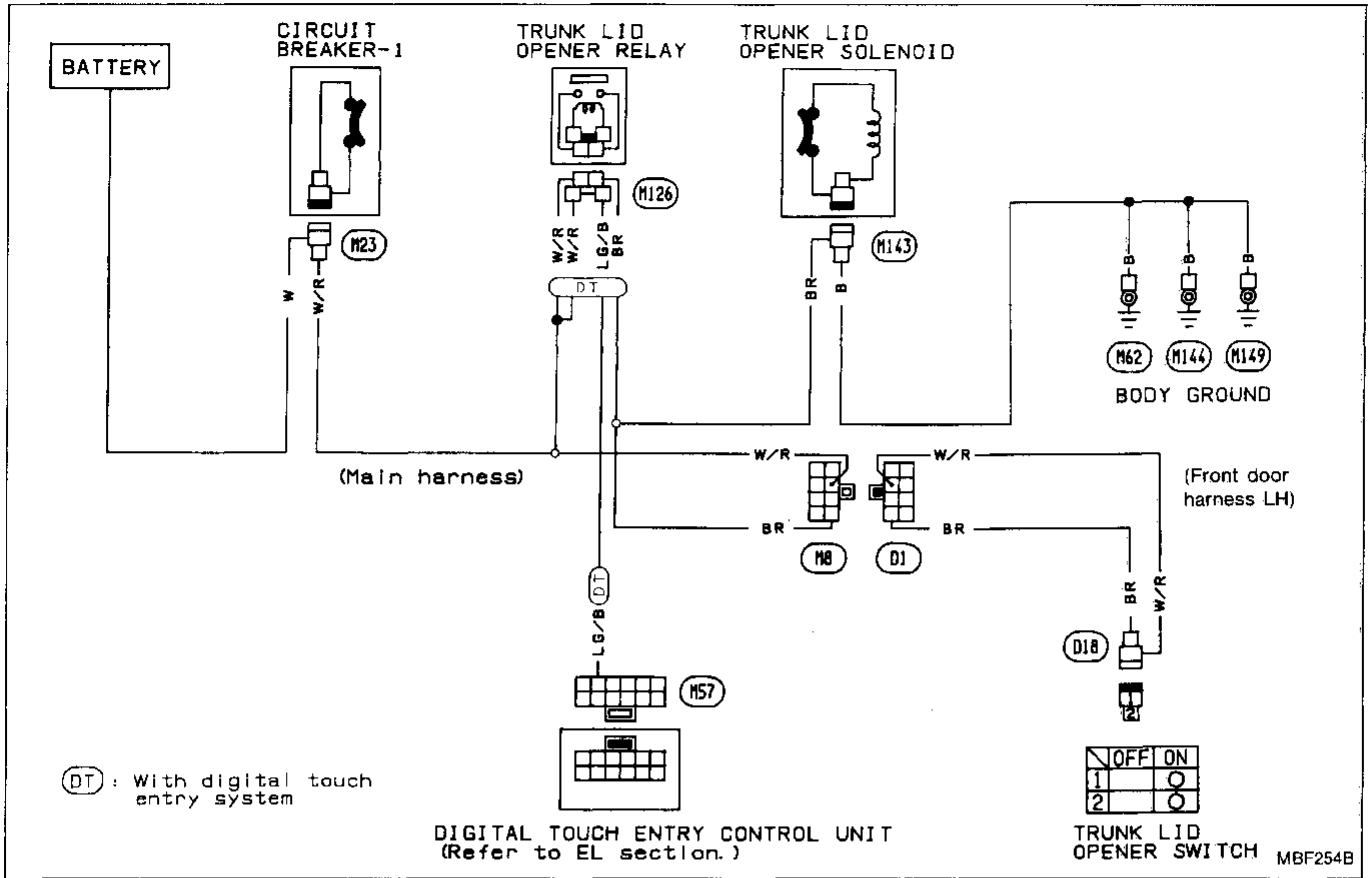

GI
MA
EV
LC
EF & EC
FE
CL
MT
AT
FA
RA
BR
ST
BF
HA
EL
IDX

DOOR

Front Door

- For removal of door trim, refer to "INTERIOR AND EXTERIOR" (BF-32).
- After adjusting door or door lock, check door lock operation.
- When disassembling rear door window, it is better to remove upper & waist roller mounting first.

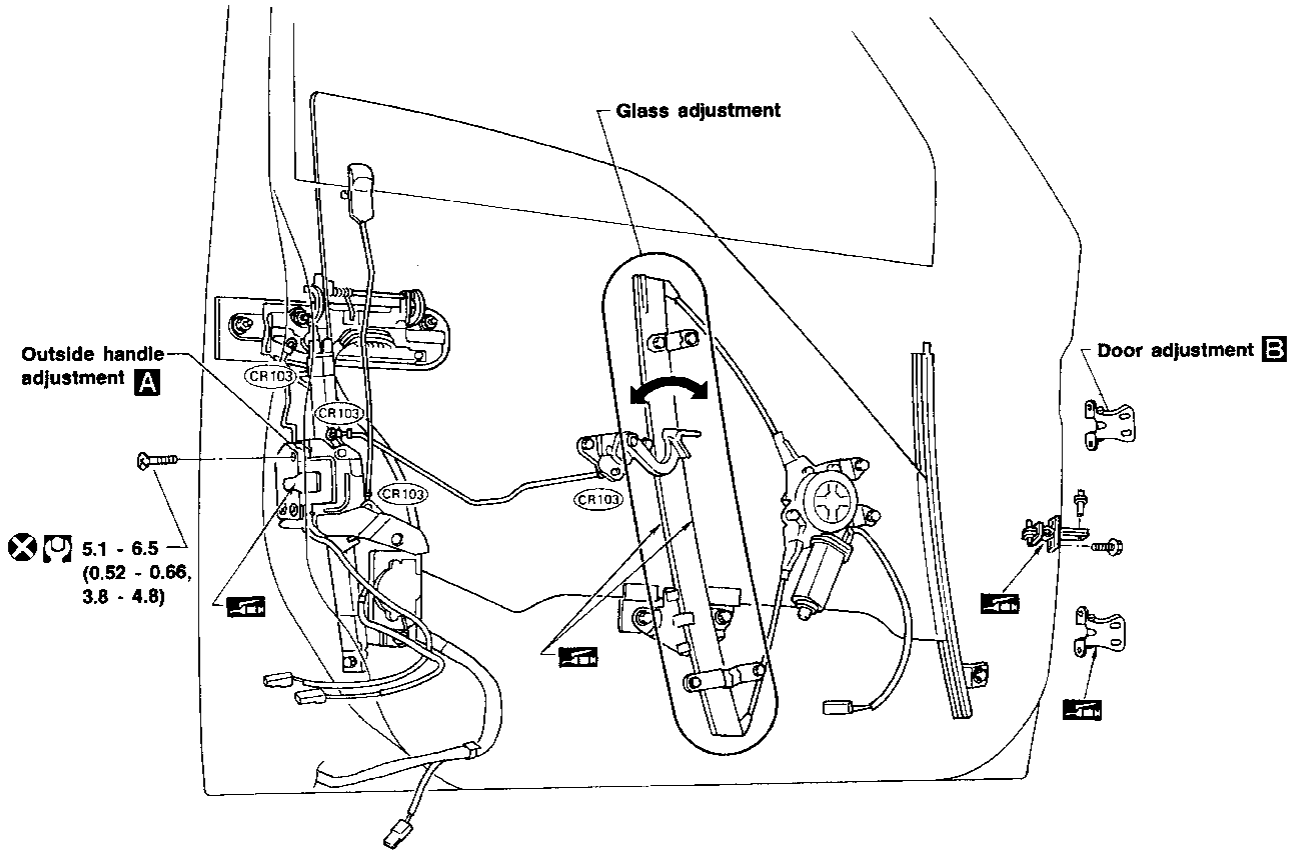

Outside handle adjustment

: N-m (kg-m, ft-lb)

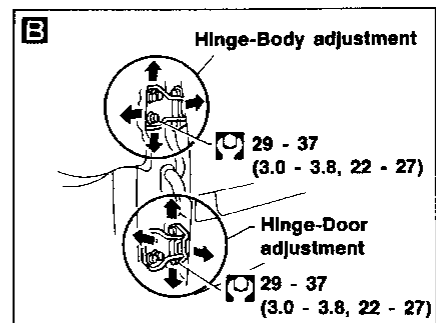
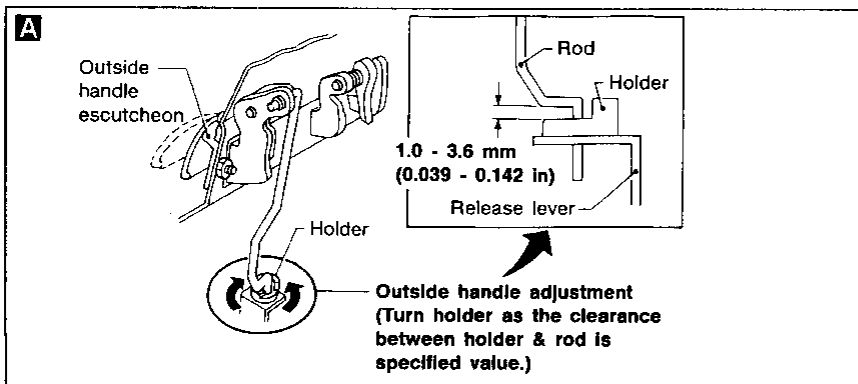

Striker adjustment

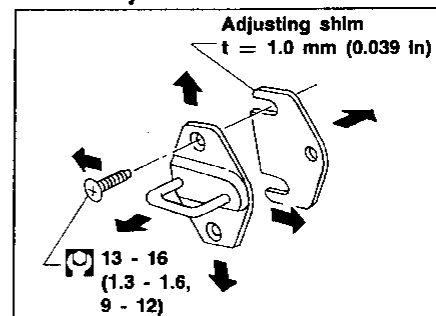

SBF989EA

DOOR

Rear Door

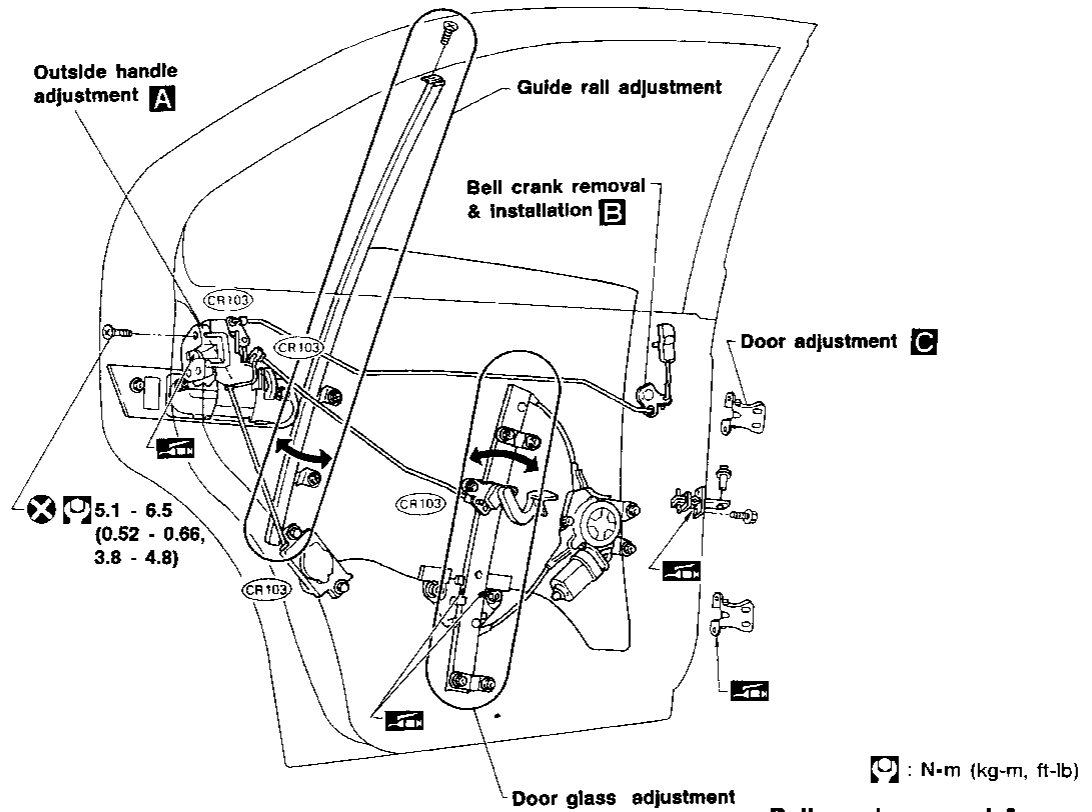

Outside handle adjustment

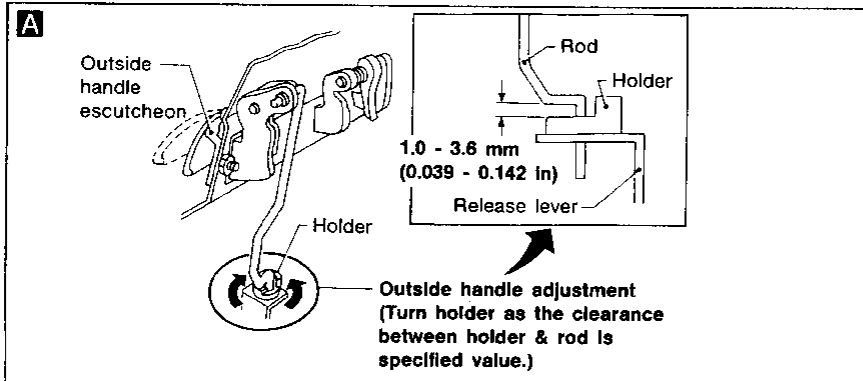

Bell crank removal & installation

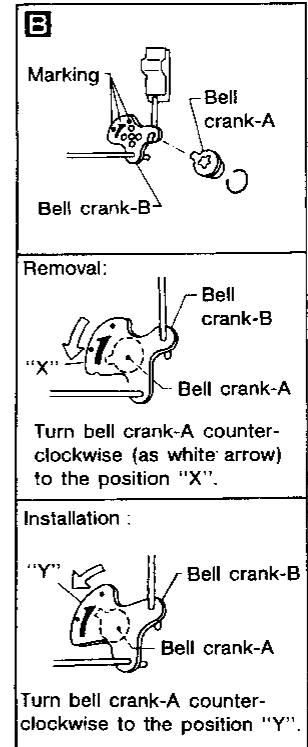

Striker adjustment

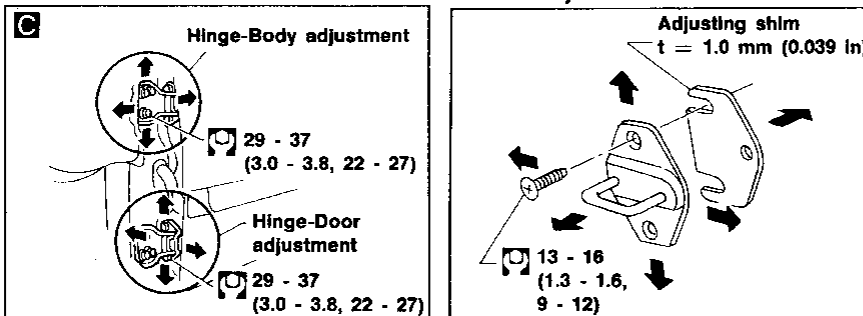

DOOR

Power Door Lock

WIRING DIAGRAM

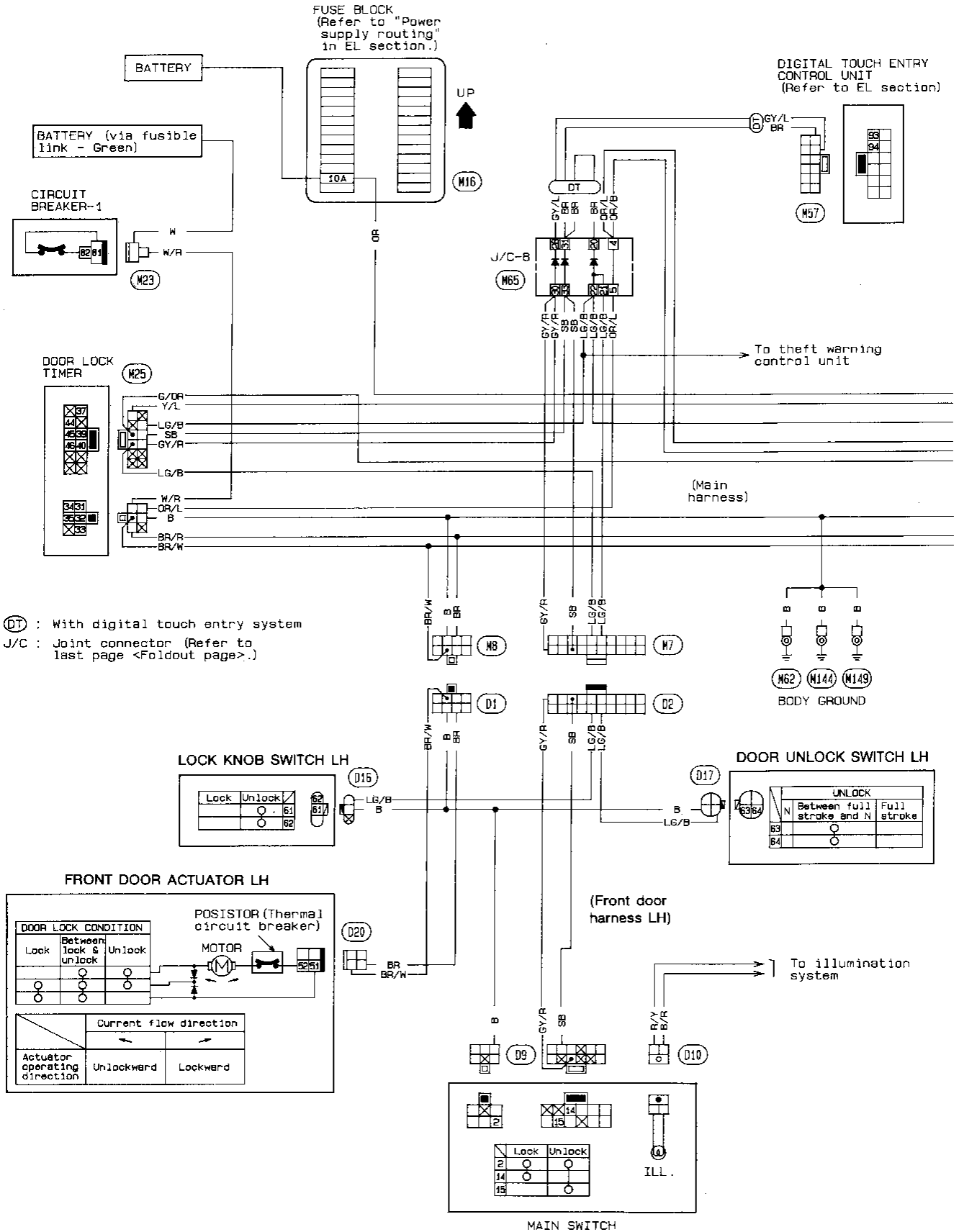

DOOR

Power Door Lock (Cont'd)

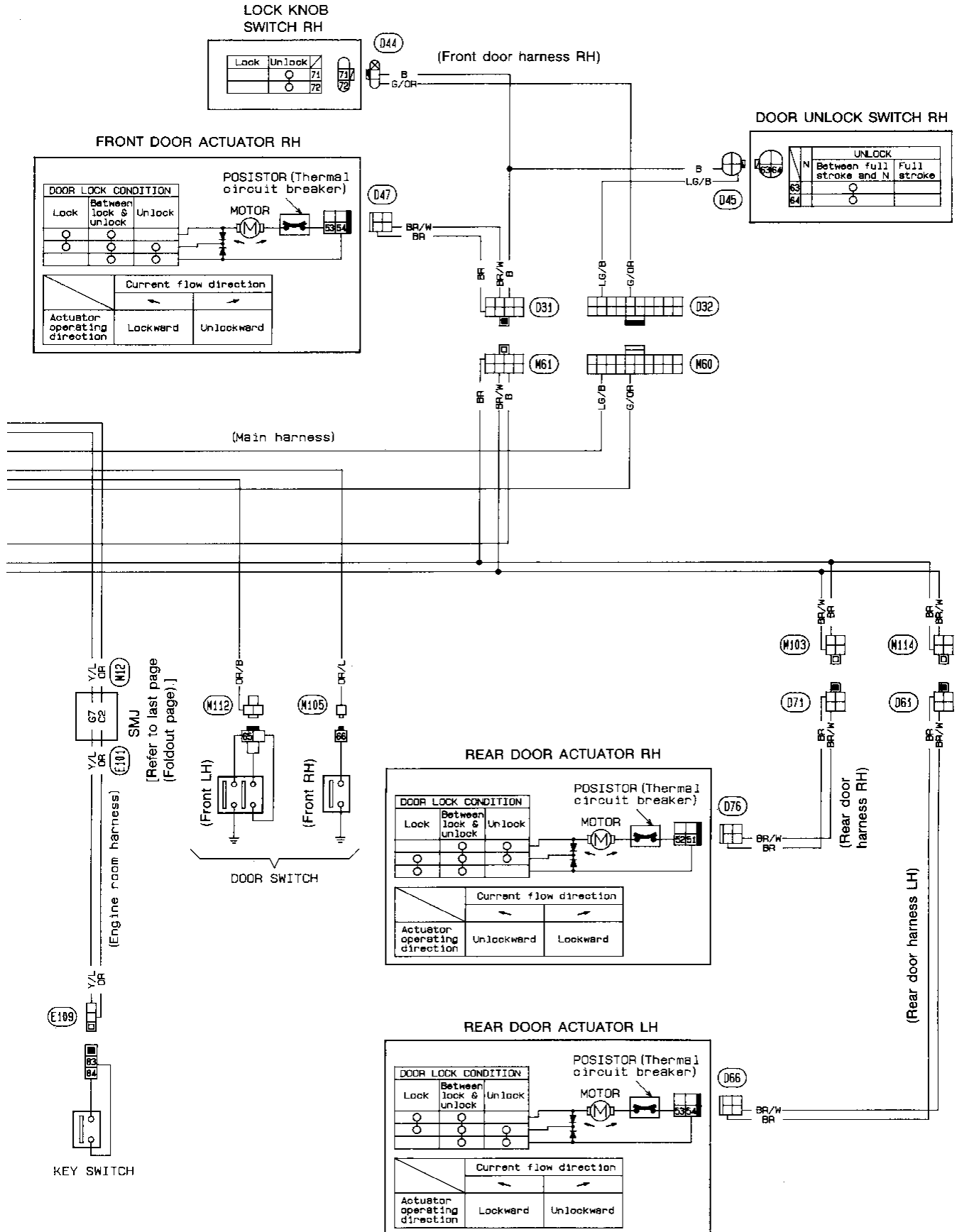

GI
MA
EM
LC
EF & EC
FE
CL
MT
AT
FA
RA
BR
ST
BF
HA
EL
IDX

DOOR

Power Door Lock (Cont'd)

DOOR LOCK TIMER INSPECTION

● Carry out the following inspections:

(1) Check power source and ground.

(2) Check input signals.

If the input signal is NG, go to ELECTRICAL COMPONENTS INSPECTION.

(3) Check output signals.

If the input signal is OK and the output signal is NG, replace the door lock timer.

If the input signal and output signal are OK, check door lock actuator in ELECTRICAL COMPONENTS INSPECTION.

Lock & unlock operation by lock knob or main switch

(The voltages are approximate values.)

	Connections		Operations			
			Lock knob switch LH	Lock knob switch RH	Main switch	
			Unlock → Lock	Unlock → Lock	N → Unlock	N → Lock
31	Power source		12V	12V	12V	12V
35	Ground		Ground	Ground	Ground	Ground
37	Input signals	Key switch	Either key switch or door switches are off. (Key is not in the ignition or all doors are closed.)			
34		Door switch				
40		Lock knob switch LH	ON → OFF (Ground) (Open)	—	—	—
39		Lock knob switch RH	—	ON → OFF (Ground) (Open)	—	—
44		Door lock key switch	—	—	—	—
46		Main switch lock	—	—	—	OFF → ON (Open) (Ground)
45		Main switch unlock	—	—	OFF → ON (Open) (Ground)	—
32	Output signals	Door lock actuator (Lock power source)	0V → 12V → 0V (Approx. 1.0 sec.)	0V → 12V → 0V (Approx. 1.0 sec.)	0V	0V → 12V → 0V (Approx. 1.0 sec.)
33		Door lock actuator (Unlock power source)	0V	0V	0V → 12V → 0V (Approx. 1.0 sec.)	0V

DOOR

Power Door Lock (Cont'd)

Unlock operation by door lock key switch

(The voltages are approximate values.)

	Connections		Operations		
			Door lock key switch LH		
			N → Unlock → N → Unlock		Unlock → Lock
31	Power source		12V	12V	12V
35	Ground		Ground	Ground	Ground
37	Input signal	Key switch	Either key switch or door switches are off. (Key is not in the ignition or all doors are closed.)		
34		Door switch			
40		Lock knob switch LH	—	—	ON → OFF (Ground) (Open)
39		Lock knob switch RH	—	—	—
44		Door lock key switch	OFF → ON → OFF → ON → OFF (Open) (Ground) (Open) (Ground) (Open)		OFF (Open)
46		Main switch lock	—	—	—
45		Main switch unlock	—	—	—
32		Output signal	Door lock actuator (Lock power source)	0V	0V
33	Door lock actuator (Unlock power source)		0V	0V → 12V → 0V (Approx. 1.0 sec.)	0V

- The second unlock signal of door lock key switch is counted when it is within approximately 4 seconds of the first signal.
- Lock operation by key is mechanically transmitted to the lock knob switch.
- Operation of door lock key switch RH is the same as LH

Key reminder operation

(The voltages are approximate values.)

	Connections		Operations		
			Lock knob switch LH	Main switch	
			Unlock → Lock → Automatically unlocked	N → Lock (→ Automatically unlocked)	
31	Power source		12V	12V	
35	Ground		0V	0V	
37	Input signal	Key switch	ON (12V) — Key is in the ignition.		
34		Door switch	ON (Ground) — Door is open.		
40		Lock knob switch LH	ON → OFF → ON (Ground) (Open) (Ground)	—	
39		Lock knob switch RH	—	—	
44		Door lock key switch	—	—	
46		Main switch lock	—	OFF → ON (Ground) (Open)	
45		Main switch unlock	—	—	
32		Output signal	Door lock actuator (Lock power source)	0V → 12V → 0V (Approx. 0.3 sec.)	0V → 12V → 0V (Approx. 0.3 sec.)
33	Door lock actuator (Unlock power source)		0V → 12V → 0V (Approx. 1.4 sec.)	0V → 12V → 0V (Approx. 1.4 sec.)	

- Operation of lock knob switch RH is the same as LH.

DOOR

Power Door Lock (Cont'd)

ELECTRICAL COMPONENTS INSPECTION

Key switch

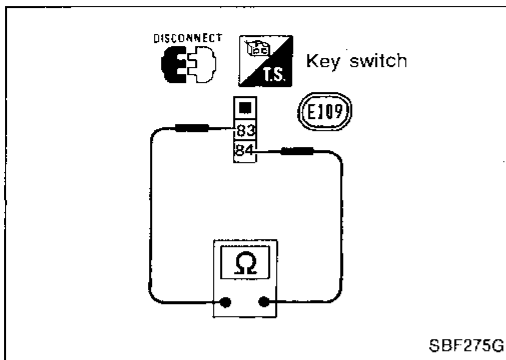

Terminals	Condition	Continuity
83 - 84	Key is in the ignition.	Yes
	Key is not in the ignition.	No

Door switch

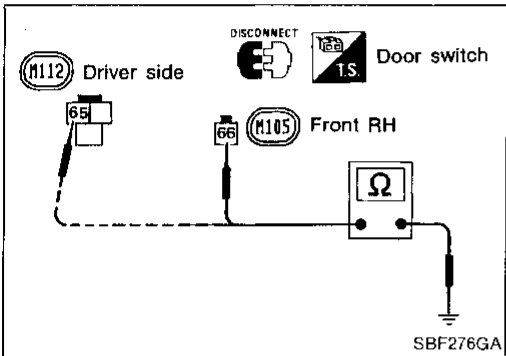

	Terminals	Condition	Continuity
Driver side	65 - Ground	Door is closed.	No
		Door is open.	Yes
Front RH	66 - Ground	Door is closed.	No
		Door is open.	Yes

Lock knob switch

(Built-in front door lock actuator)

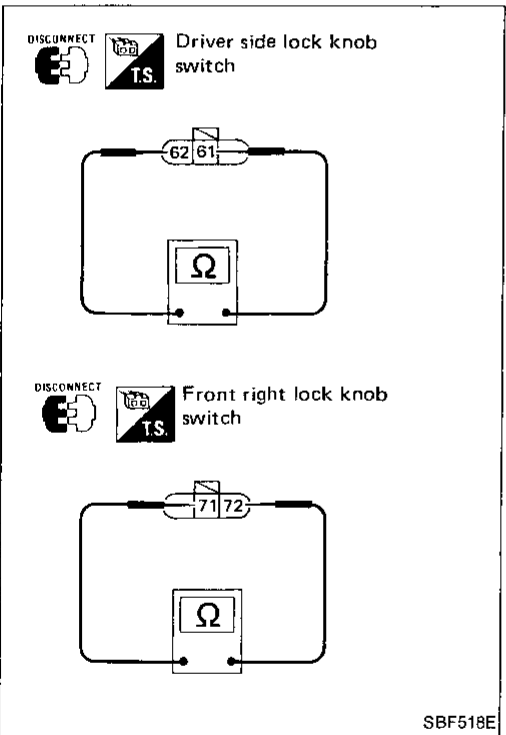

	Terminals	Condition	Continuity
Driver side	61 - 62	Lock	No
		Unlock	Yes
Front right	71 - 72	Lock	No
		Unlock	Yes

Door unlock key switch

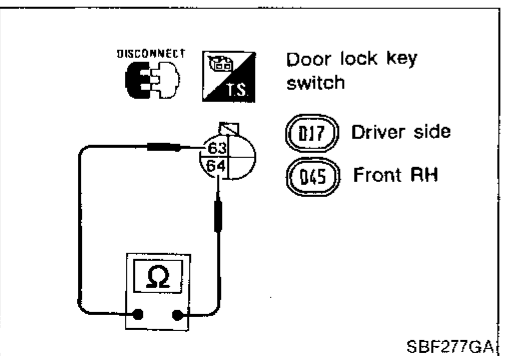

Terminals	Operation	Continuity
63 - 64	Key is turned toward unlock	Yes
	Except above.	No

DOOR

Power Door Lock (Cont'd)

Main switch

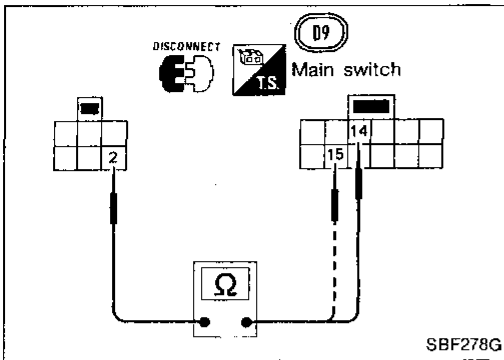

Terminals	Operation	Continuity
② - ⑭	Lock	Yes
	Neutral and unlock	No
② - ⑮	Unlock	Yes
	Neutral and unlock	No

GI
WA

EM

Door lock actuator

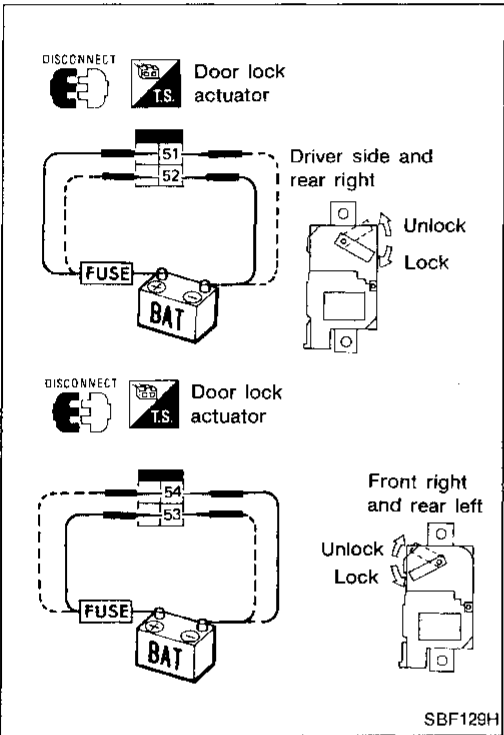

	Terminals		Operation
	⊕	⊖	
Driver side and rear right	⑤①	⑤②	Lock
	⑤②	⑤①	Unlock
Front right and rear left	⑤③	⑤④	Lock
	⑤④	⑤③	Unlock

LC

EF &
EC

FE

CL

MT

AT

FA

RA

BR

ST

BF

HA

EL

IDX

DOOR

Power Window

WIRING DIAGRAM

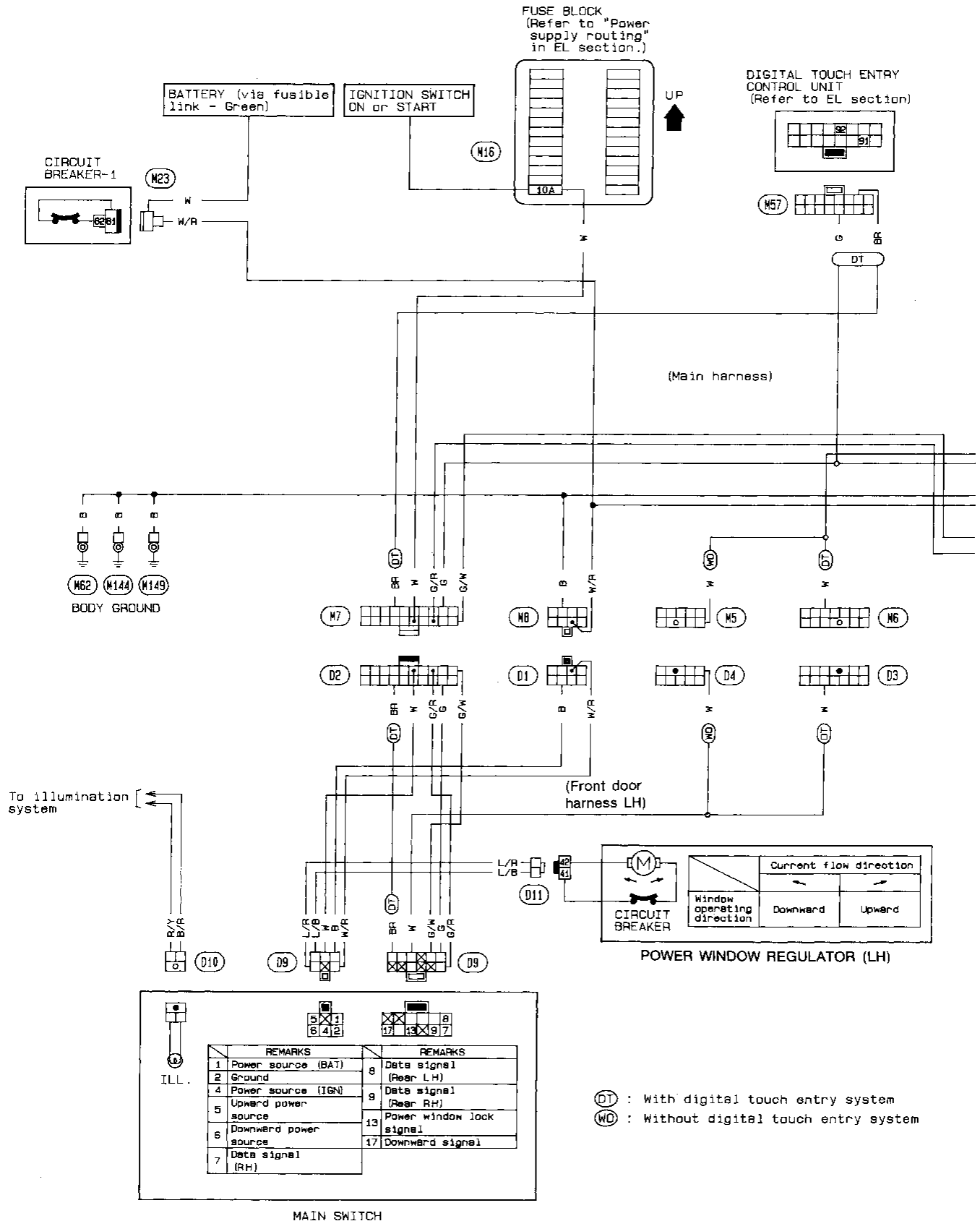

DOOR

Power Window (Cont'd)

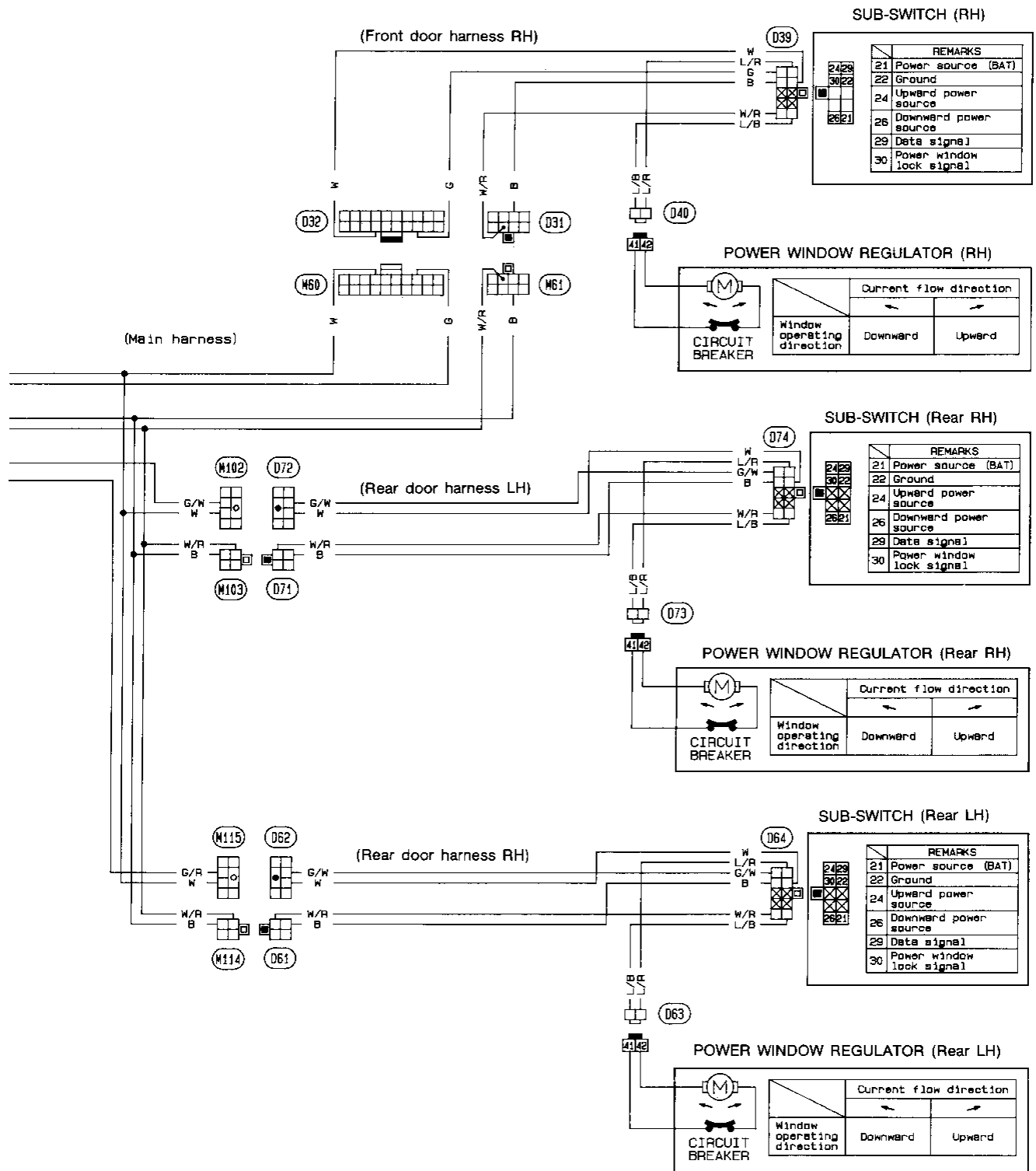

GI
MA
EM
LC
EF & EC
FE
CL
MT
AT
FA
RA
BR
ST
BF
HA
EL
IDX

DOOR — Trouble Diagnoses for Power Window

Contents

Symptom Chart	BF-20
Main Power Supply and Ground Circuit Check	BF-21
Harness Layout	BF-22
Circuit Diagram for Quick Pinpoint Check	BF-23
Diagnostic Procedure 1	
(Check driver side window motor circuit.)	BF-24
Diagnostic Procedure 2	
(Check power window lock signal circuit.)	BF-25
(Check passenger window motor circuit.)	BF-26
Diagnostic Procedure 3	
(Check data line, signal circuit.)	BF-27
Diagnostic Procedure 4	
(Check digital touch entry control circuit.)	BF-28
Electrical Components Inspection	BF-28

Since left and right component parts are basically the same, harness layout and methods for electrical components inspection are shown for one side only.

Although methods for checking component parts on both sides are described in the flow chart, making it easier to troubleshoot, apply checking procedures to either side that have malfunction during trouble diagnoses.

Symptom Chart

Procedure	Main Power Supply and Ground Circuit Check			Diagnostic Procedure				Electrical Components Inspection	Remarks
	BF-21	BF-21	BF-21	BF-24	BF-25	BF-27	BF-28		
Reference Page	BF-21	BF-21	BF-21	BF-24	BF-25	BF-27	BF-28	BF-28	—
SYMPTOM	Procedure 1	Procedure 2	Procedure 3	Procedure 1	Procedure 2	Procedure 3	Procedure 4	Power window motor(s)	—
All power windows cannot be operated.	<input type="radio"/>		<input type="radio"/>	<input type="radio"/>	<input type="radio"/>	<input type="radio"/>		<input type="radio"/>	—
Driver side power window cannot be operated but other windows can be operated.				<input type="radio"/>				<input type="radio"/>	—
Passenger power windows cannot be operated.		<input type="radio"/>			<input type="radio"/>			<input type="radio"/>	—
Passenger power windows cannot be operated by main switch but can be operated by passenger's switches.	<input type="radio"/>					<input type="radio"/>			—
Power windows cannot be opened by digital touch entry system but can be operated by other switches.							<input type="radio"/>		Digital touch entry system

DOOR — Trouble Diagnoses for Power Window

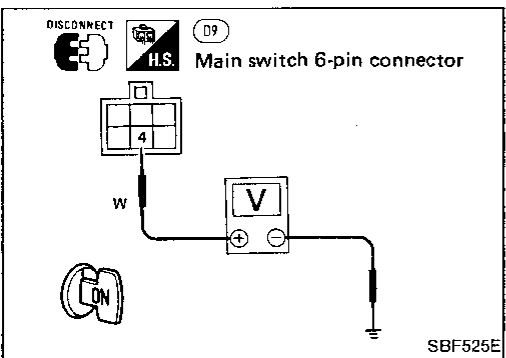
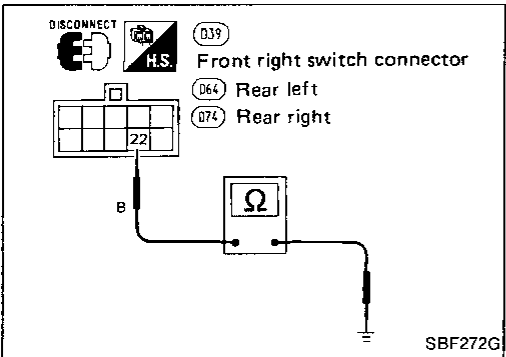
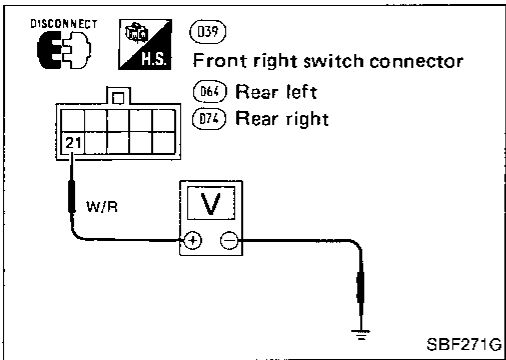
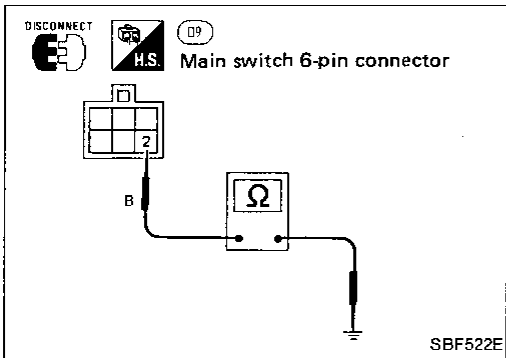
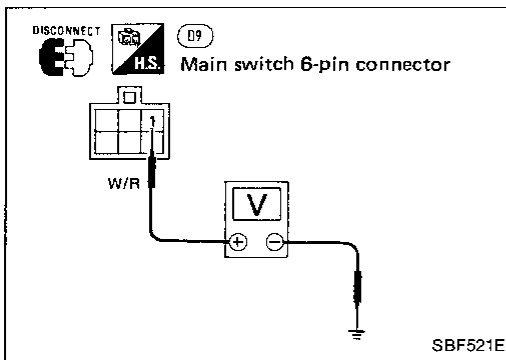

Main Power Supply and Ground Circuit Check

PROCEDURE 1

Main power supply

Terminals	Battery voltage existence
① - Ground	Yes

Ground circuit

Terminals	Continuity
② - Ground	Yes

PROCEDURE 2

Power supply for sub-switch

Terminals	Battery voltage existence
③ - Ground	Yes

Ground circuit for sub-switch

Terminals	Continuity
④ - Ground	Yes

PROCEDURE 3

Power supply for ignition signal

Terminals	Ignition switch	Battery voltage existence
④ - Ground	ON	Yes

GI

MA

EM

LC

EF &
EC

FE

CL

WT

AT

FA

RA

BR

ST

BF

HA

EL

IDX

DOOR — Trouble Diagnoses for Power Window

Harness Layout

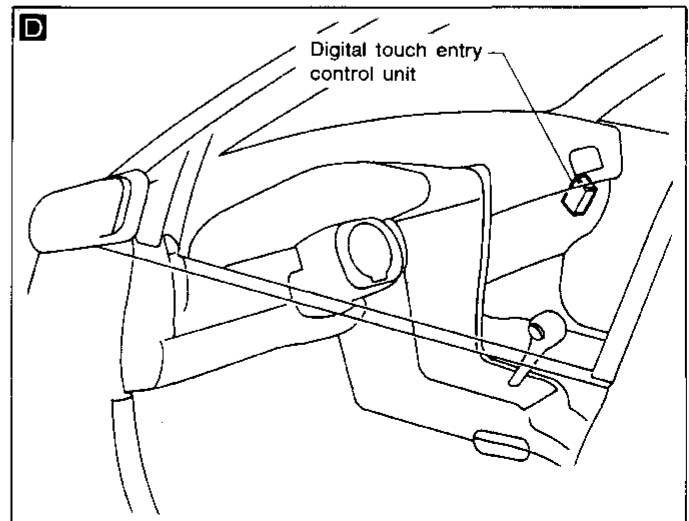
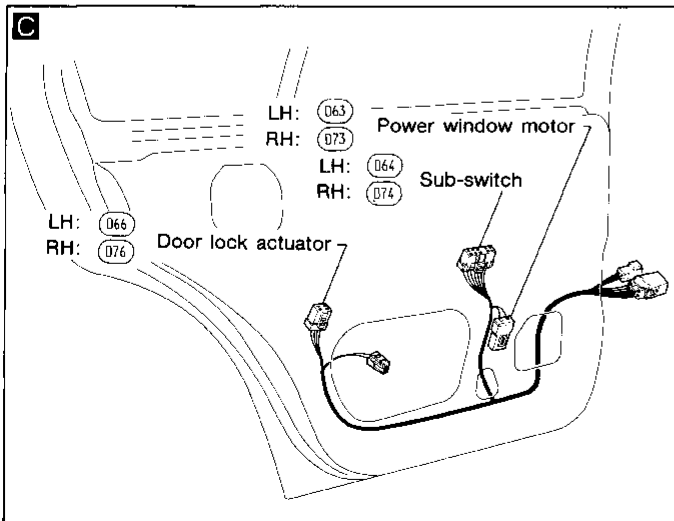
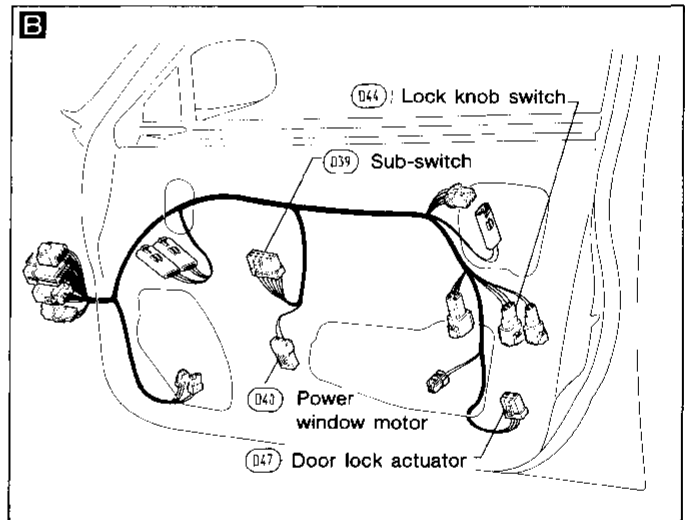
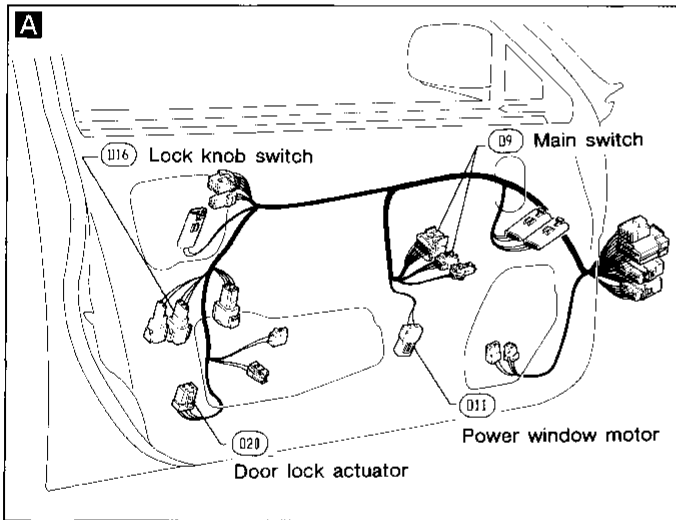
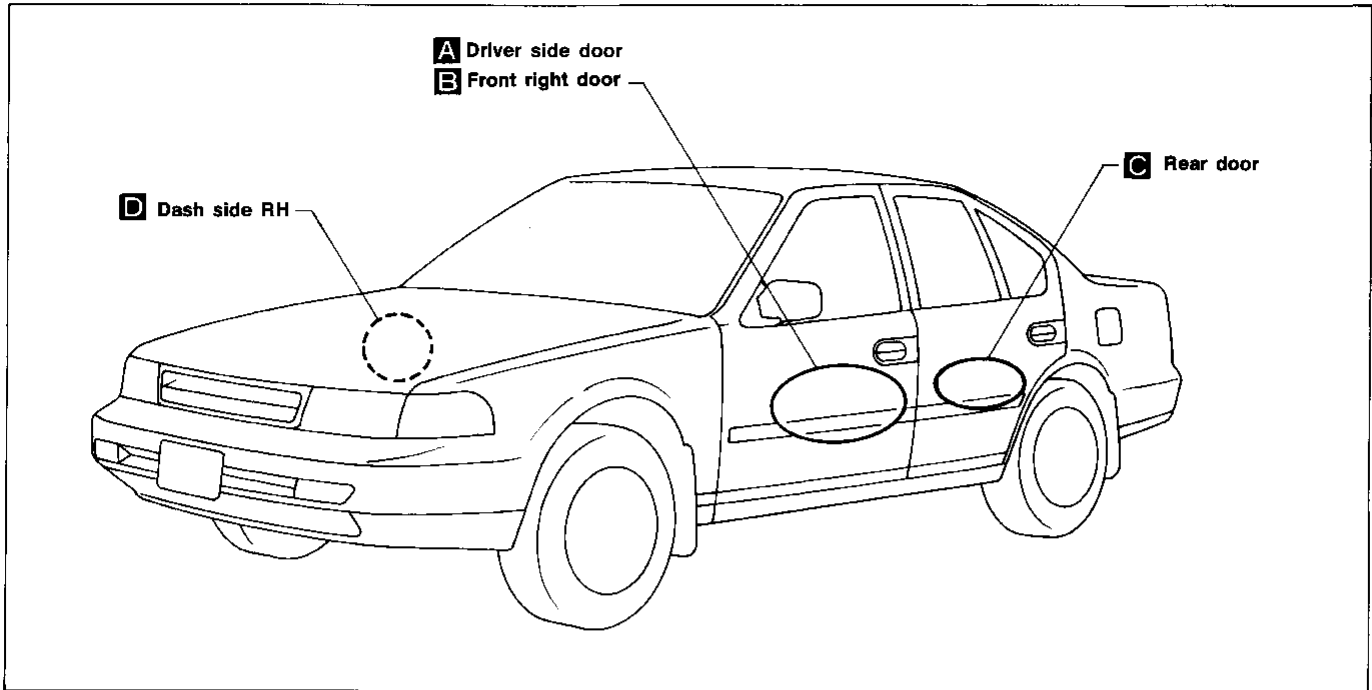

SBF555EA

DOOR — Trouble Diagnoses for Power Window

Circuit Diagram for Quick Pinpoint Check

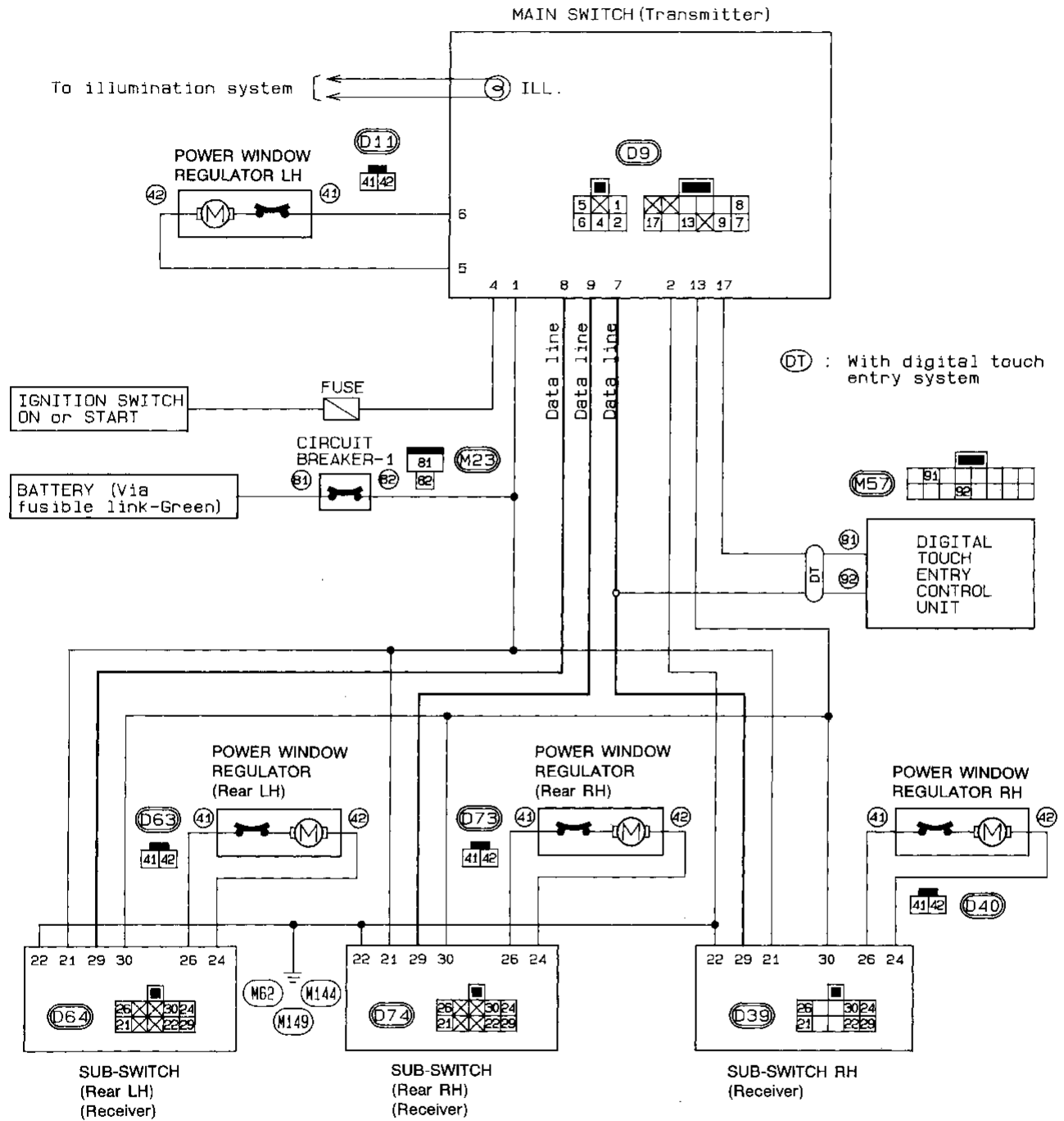

GI
MA
EM
LC
EF & EC
FE
CL
MT
AT
FA
RA
BR
ST
BF
HA
EL
IDX

DOOR — Trouble Diagnoses for Power Window

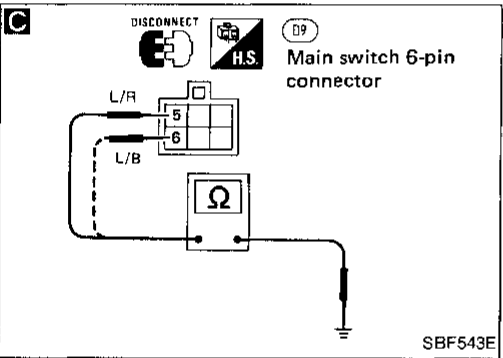
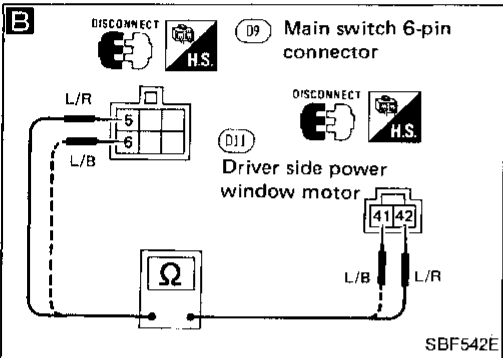
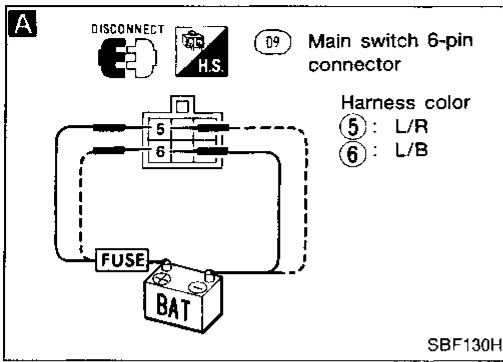

Diagnostic Procedure 1

SYMPTOM:

Driver side power window cannot be operated but other power windows can be operated.

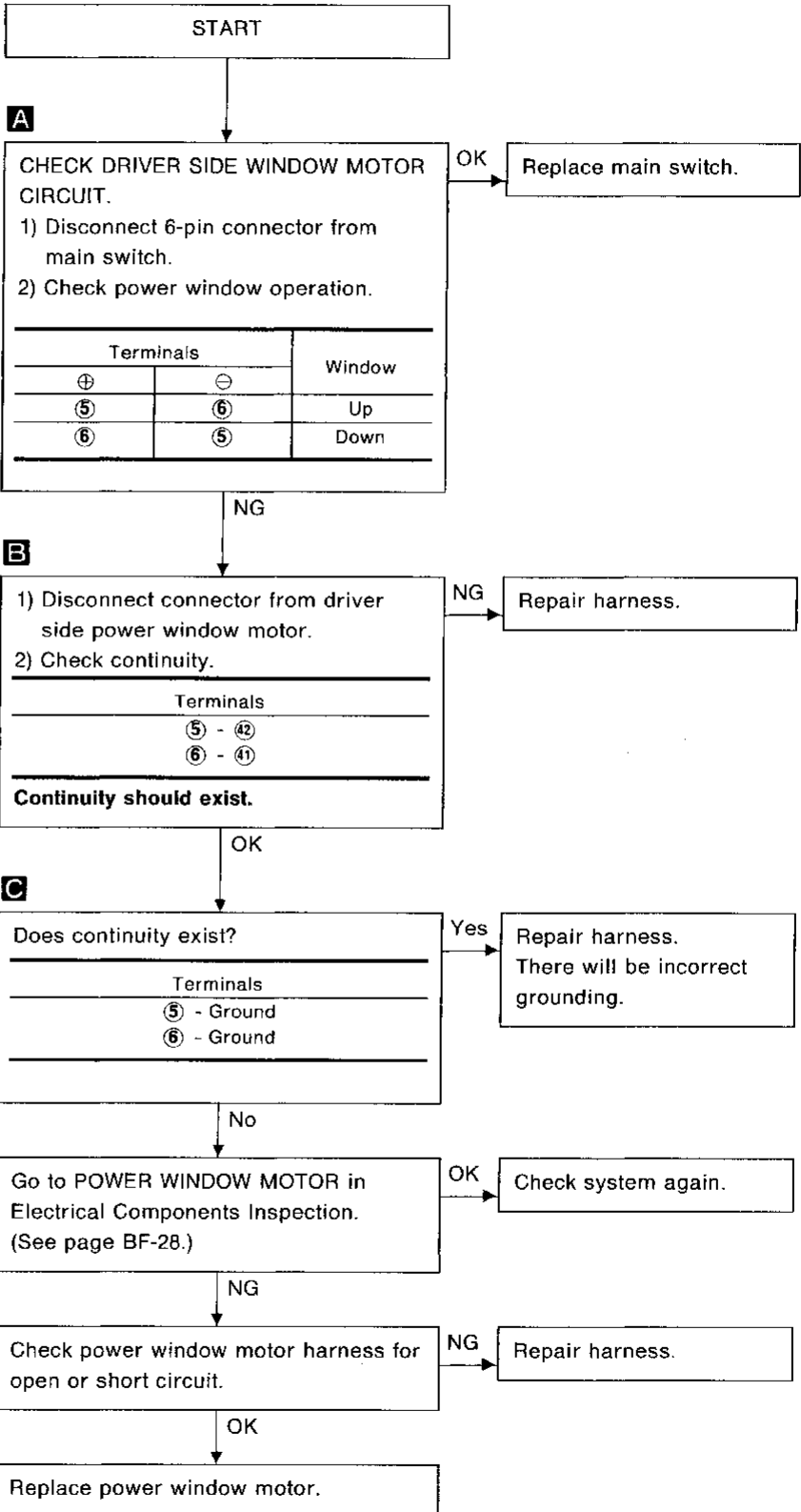

DOOR — Trouble Diagnoses for Power Window

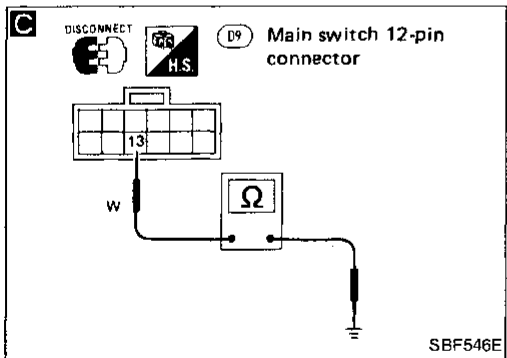
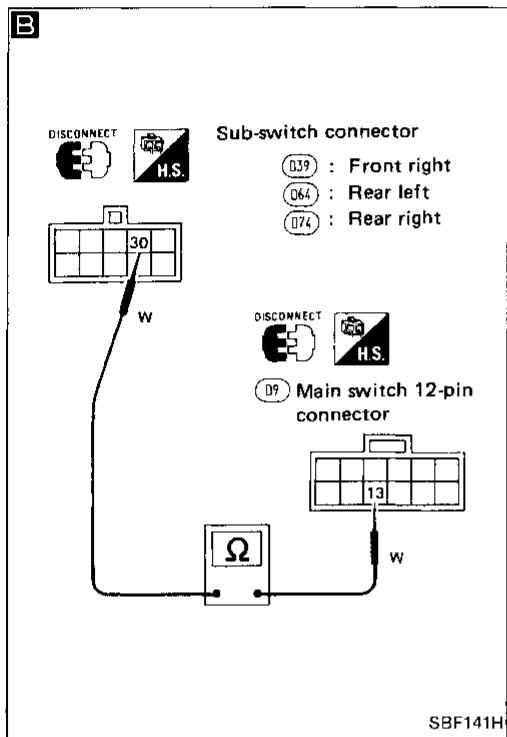
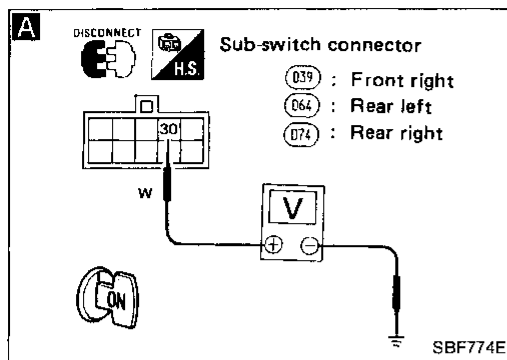

Diagnostic Procedure 2

SYMPTOM:

Passenger power windows cannot be operated but driver side power window can be operated.

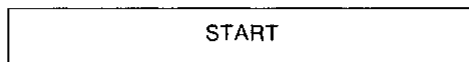

A

CHECK POWER WINDOW LOCK SIGNAL CIRCUIT.

1) Disconnect connectors from all switches except main switch.

2) Check battery voltage between terminal 30 for each connector and ground while ignition switch is "ON".

OK → Go to **A** on next page.

Terminals	Power window lock switch	Battery voltage exists
30 - Ground	ON	No
	OFF	Yes

NG

B

1) Disconnect 12-pin connector from main switch.

2) Check continuity between terminal 30 for each connector and 13 for main switch connector.

NG → Repair harness.

Terminals
30 - 13

Continuity should exist.

OK

C

Does continuity exist?

Terminals
13 - Ground

Yes → Repair harness. There will be incorrect grounding.

No

Replace main switch.

GI
MA
EM
LC
EF & EC
FE
CL
MT
AT
FA
RA
BR
ST
BF
HA
EL
IDX

DOOR — Trouble Diagnoses for Power Window

Diagnostic Procedure 2 (Cont'd)

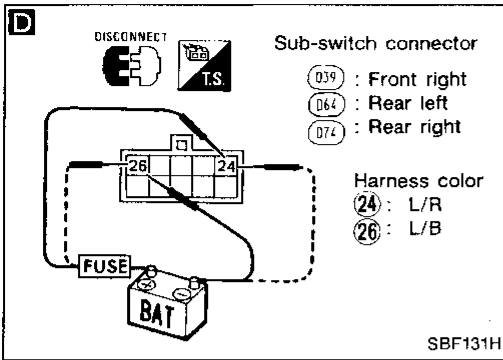

A

D

CHECK PASSENGER WINDOW MOTOR CIRCUIT.

1) Disconnect connector from sub-switches.
2) Check power window.

OK → Replace sub-switch.

Terminals		Window operation
⊕	⊖	
24	26	Up
26	24	Down

NG

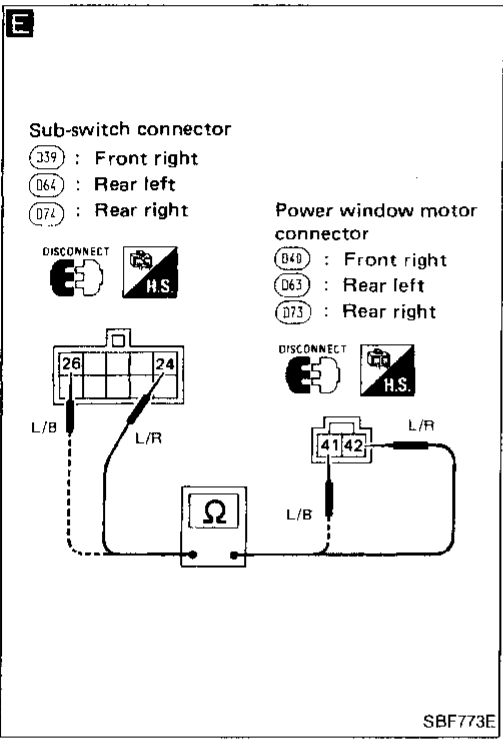

E

1) Disconnect connector from power window motor.
2) Check continuity.

NG → Repair harness.

Terminals	
24 - 42	
26 - 41	

Continuity should exist.

OK

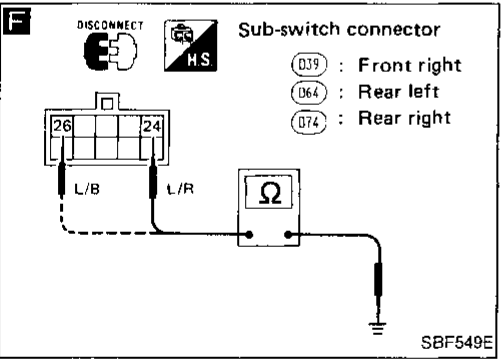

F

Does continuity exist?

Yes → Repair harness. There will be incorrect grounding.

Terminals	
24 - Ground	
26 - Ground	

No

Go to **POWER WINDOW MOTOR** in Electrical Components Inspection. (See page BF-28.)

OK → Check system again.

NG

Check power window motor harness for open or short circuit.

NG → Repair harness.

OK

Replace power window motor.

DOOR — Trouble Diagnoses for Power Window

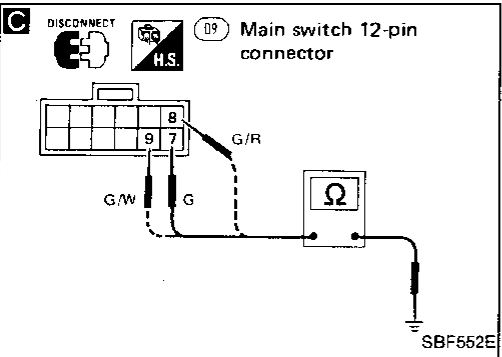
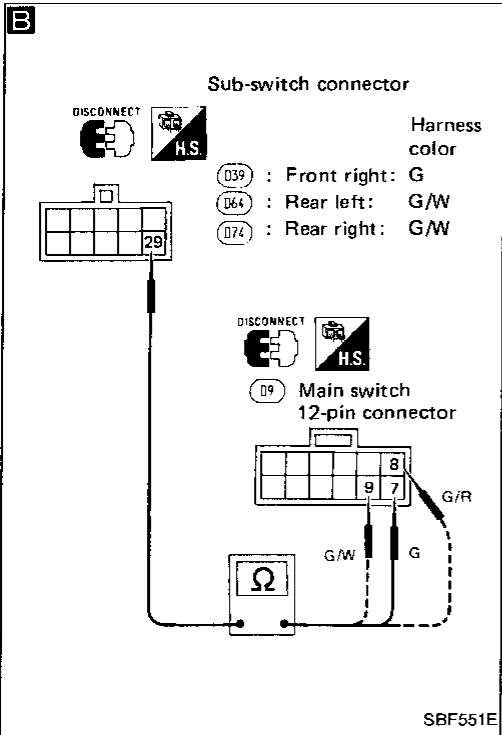
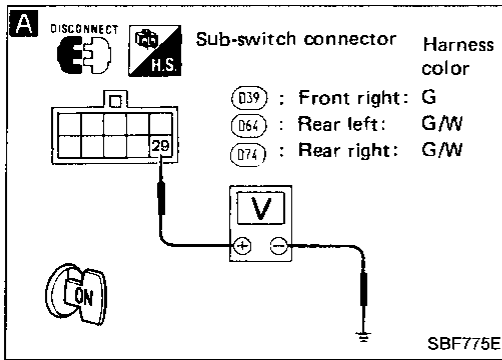

Diagnostic Procedure 3

SYMPTOM:

Passenger power windows cannot be operated by main switch but can be operated by passenger's switches.

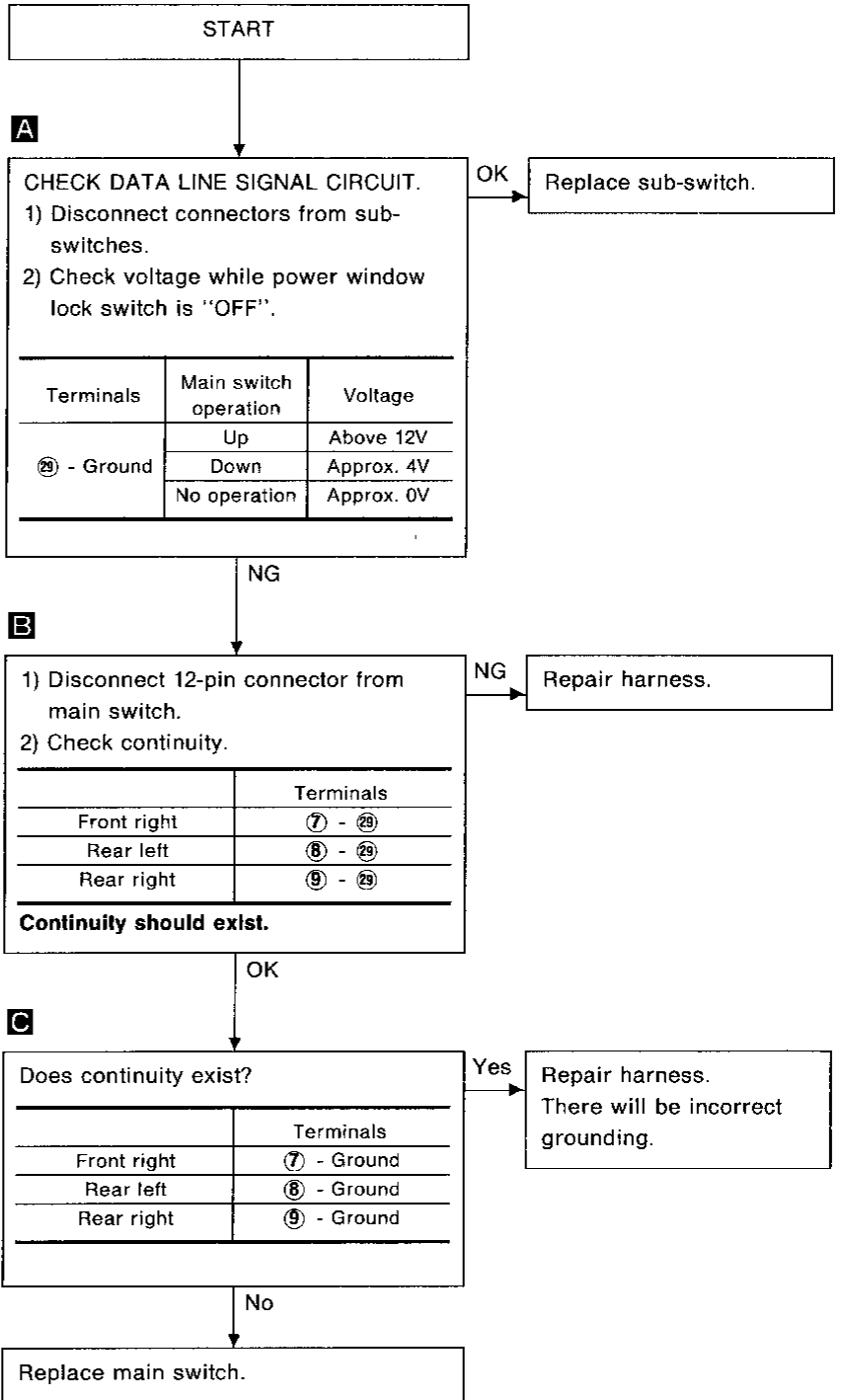

GI
MA
EM
LC
EF & EC
FE
CL
MT
AT
FA
RA
BR
ST
BF
HA
EL
IDX

DOOR — Trouble Diagnoses for Power Window

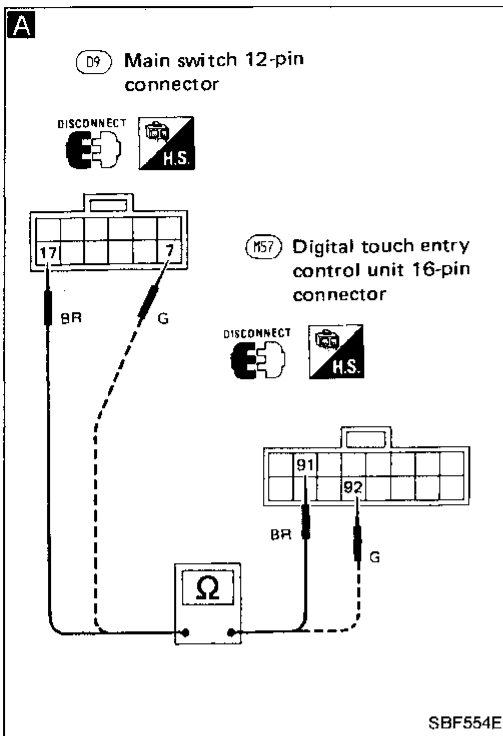

Diagnostic Procedure 4

SYMPTOM:

Power windows cannot be opened by digital touch entry system but can be operated by other switches.

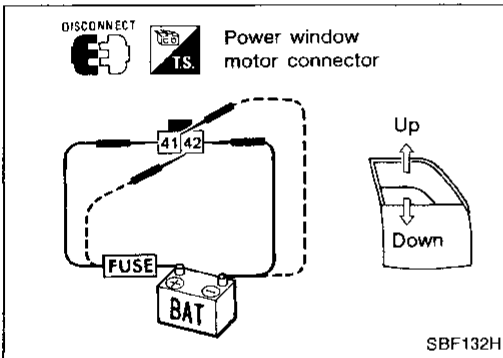
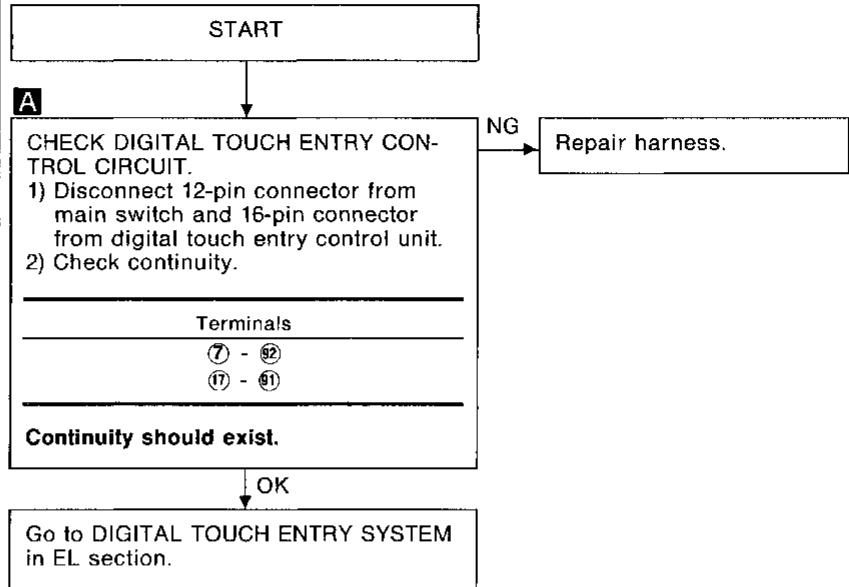

Electrical Components Inspection

POWER WINDOW MOTOR

Terminals		Operation
⊕	⊖	
④①	④②	Downward
④②	④①	Upward

INSTRUMENT PANEL

- When removing instrument panel assembly, remove defroster grille, combination meter, A/C or heater control, cluster lid C and SMJ first.

CAUTION:

- **Disconnect ground terminal from battery in advance.**
- **Disconnect air bag system line in advance.**
- **Be careful not to scratch pad and other parts.**

HEAD-UP DISPLAY (HUD)

- When removing HUD finisher, be extremely careful not to scratch HUD's reflective surface. To avoid scratching, cover HUD's reflective surface or finisher with a cloth or vinyl sheet. **L**

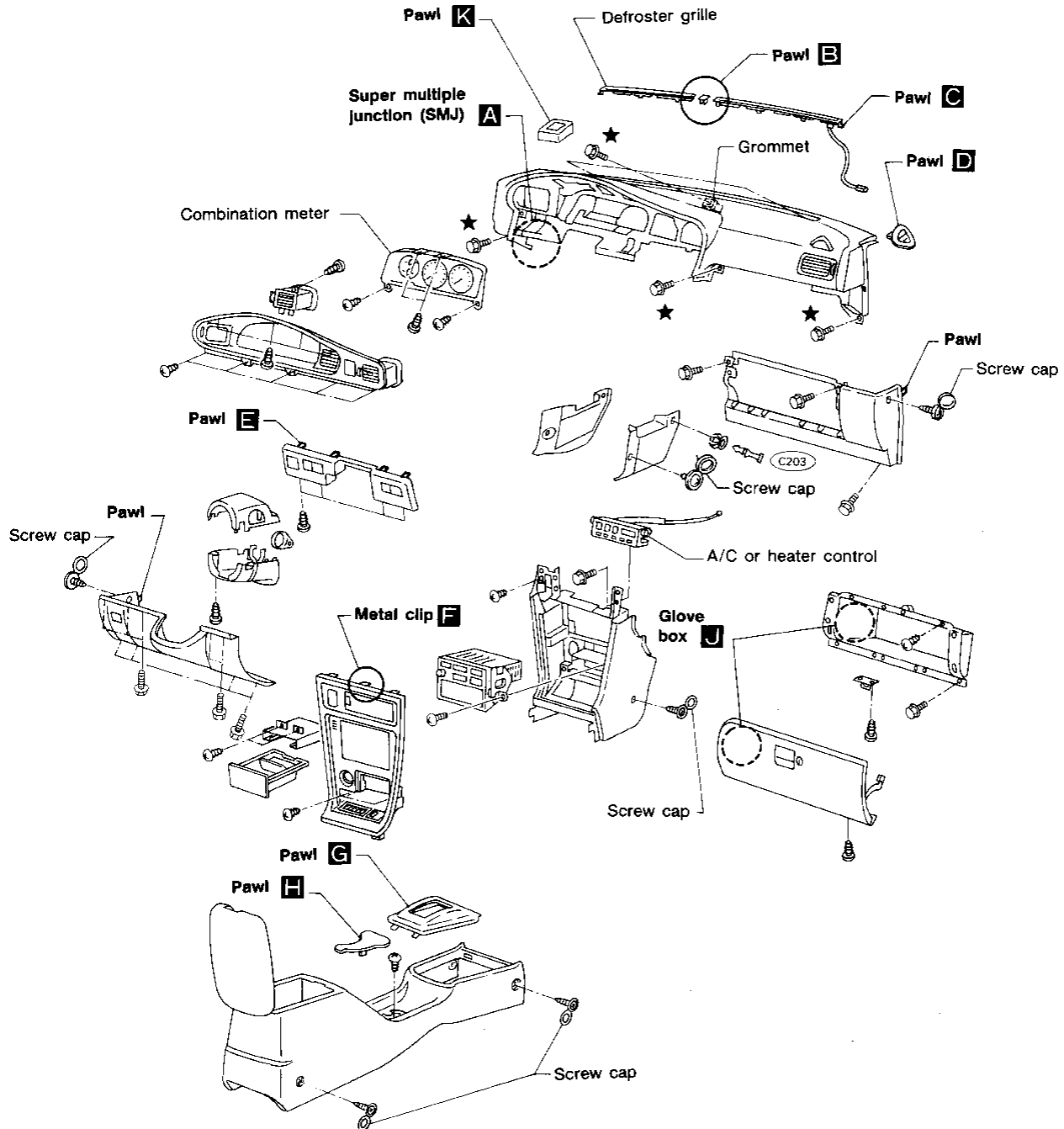

★ : Instrument panel assembly mounting bolts

INSTRUMENT PANEL

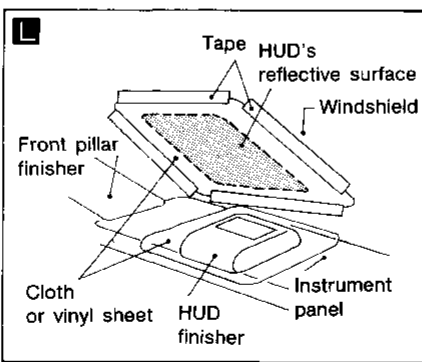
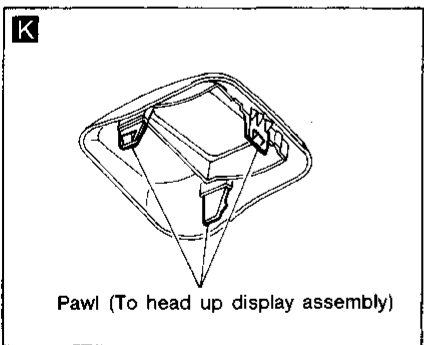
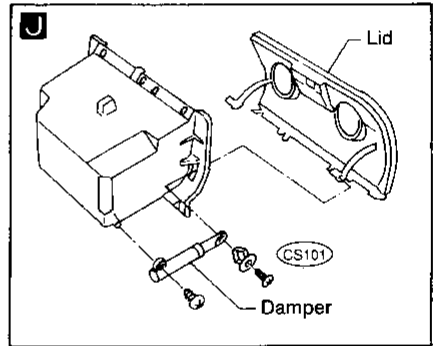
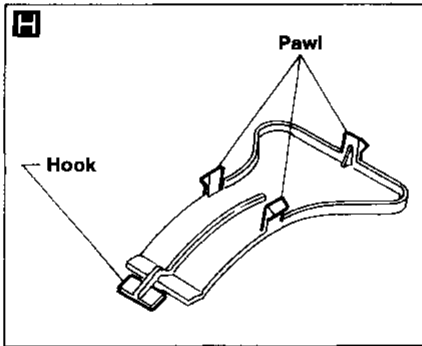
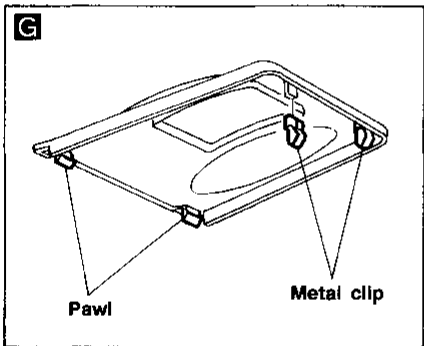
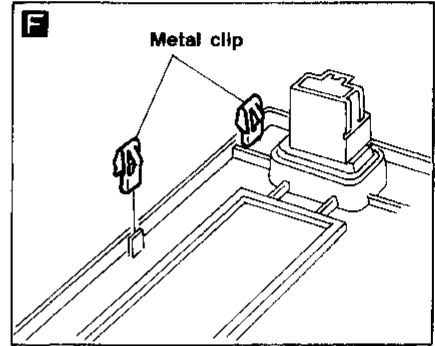
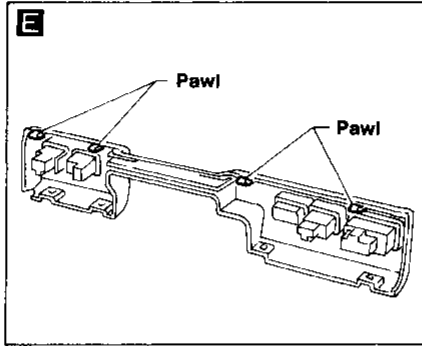
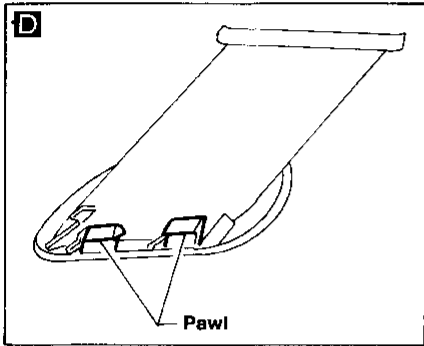
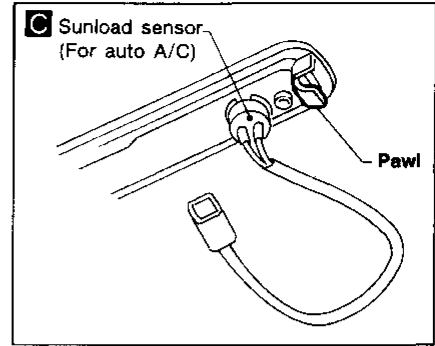
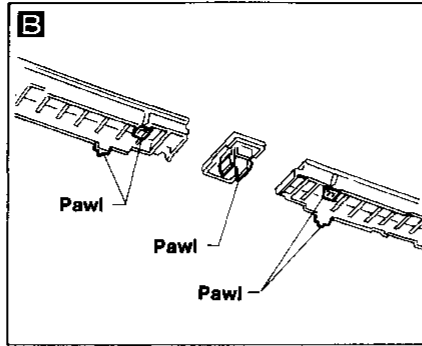
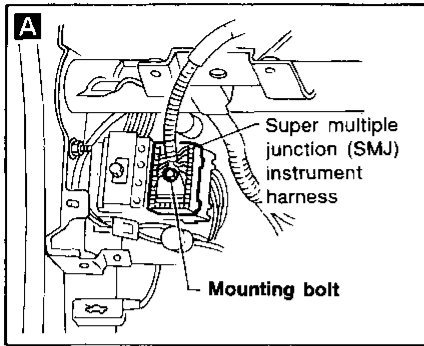

Interior

SIDE AND FLOOR TRIM — Passenger room

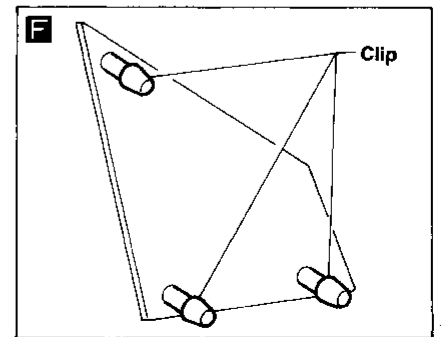
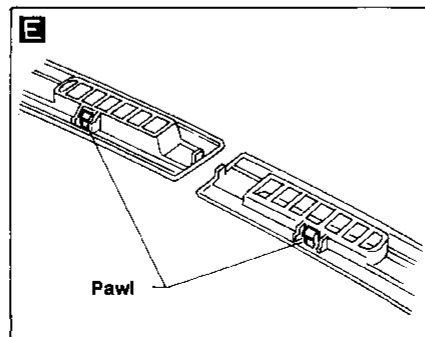
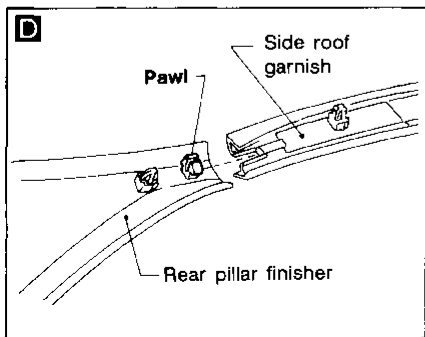
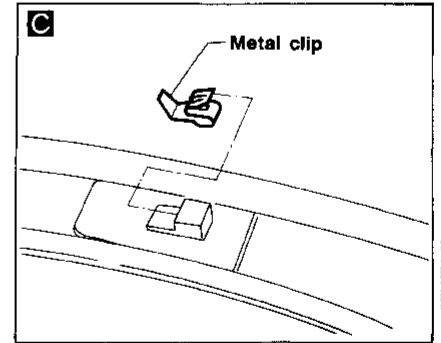
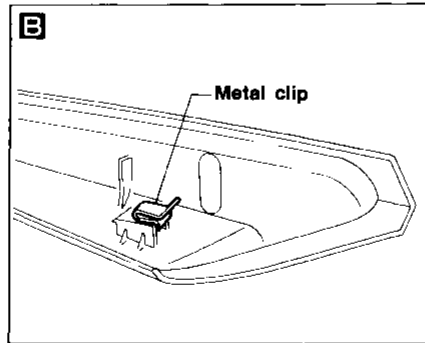
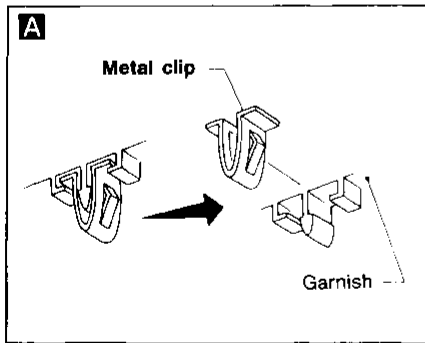
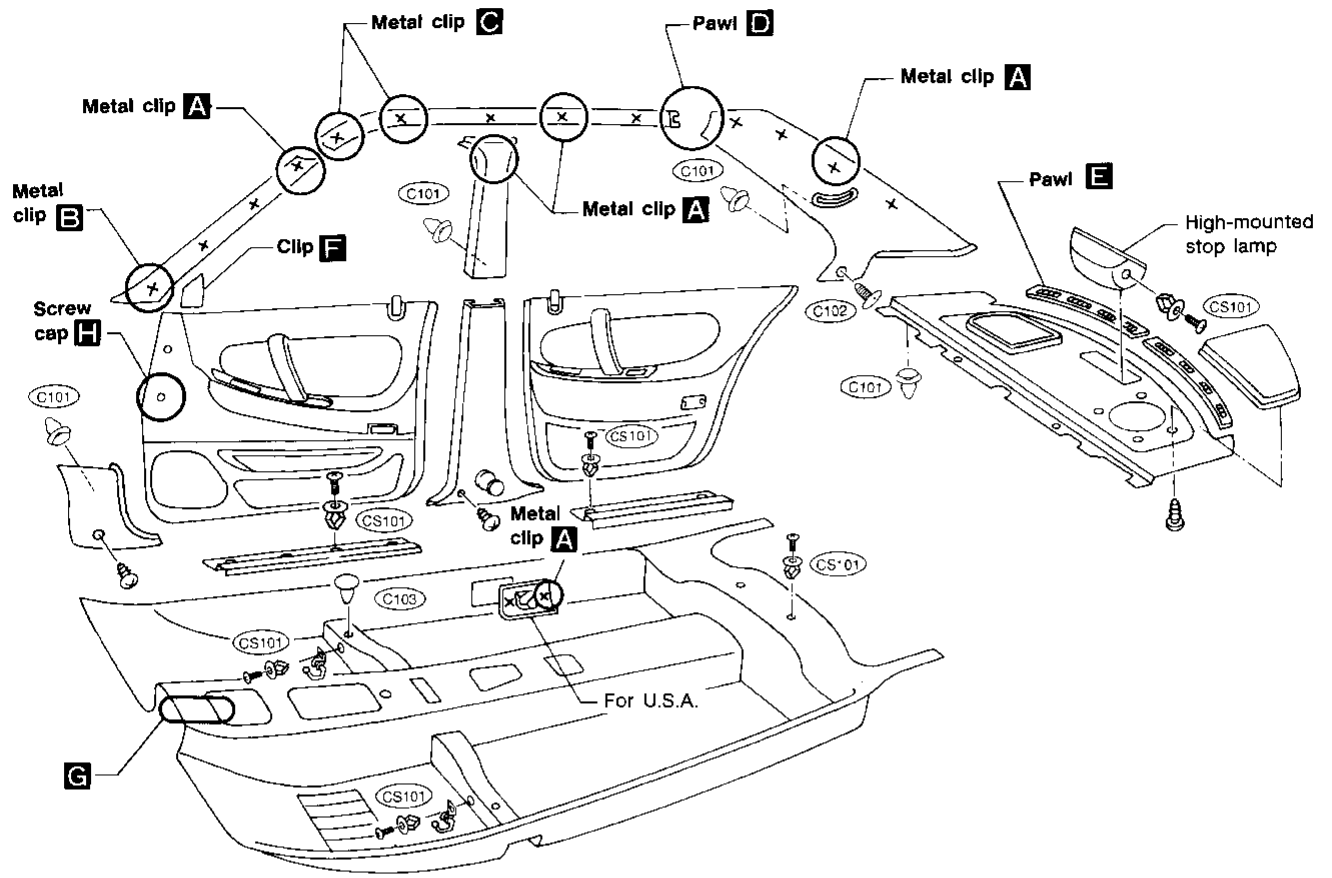

INTERIOR AND EXTERIOR

Interior (Cont'd)

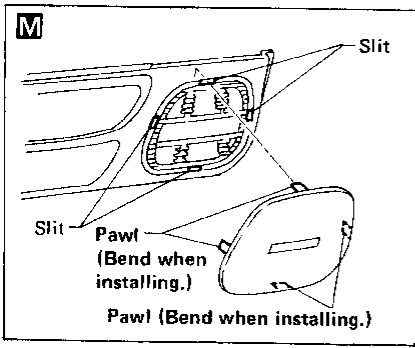
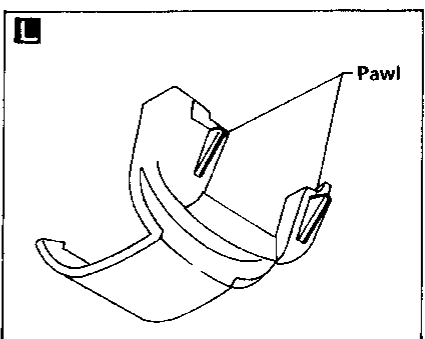
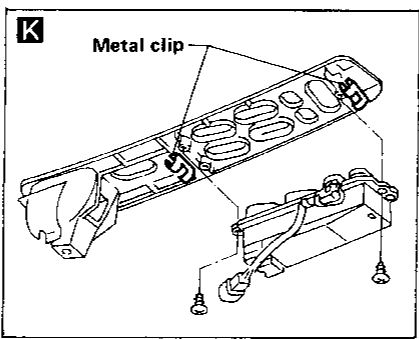
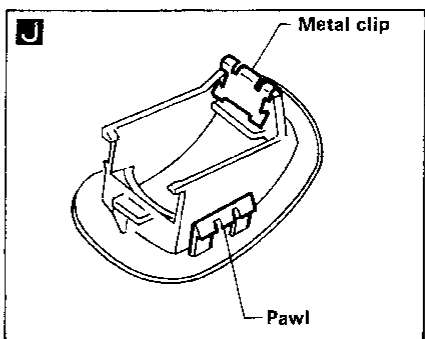
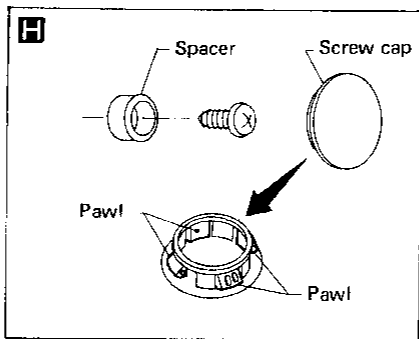
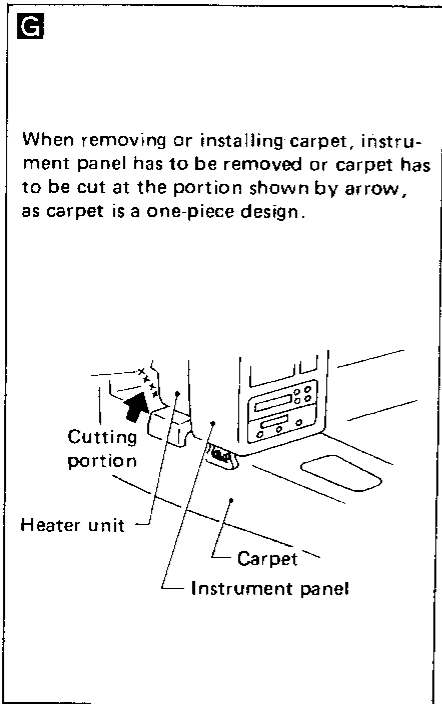
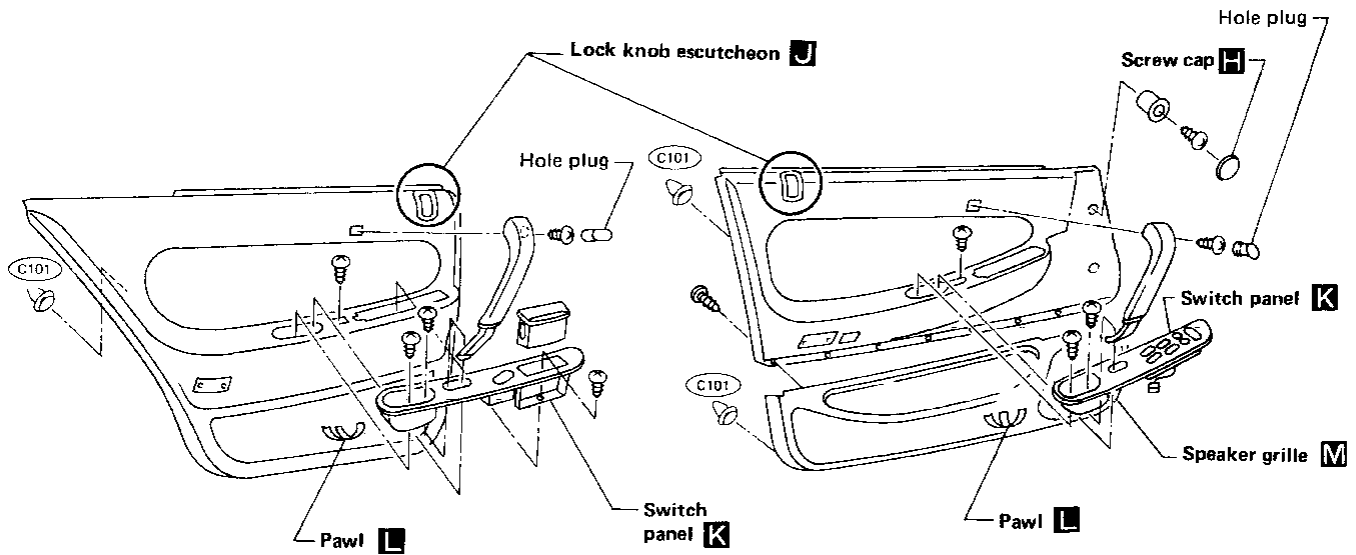

INTERIOR AND EXTERIOR

Interior (Cont'd)

LUGGAGE ROOM TRIM — Trunk space

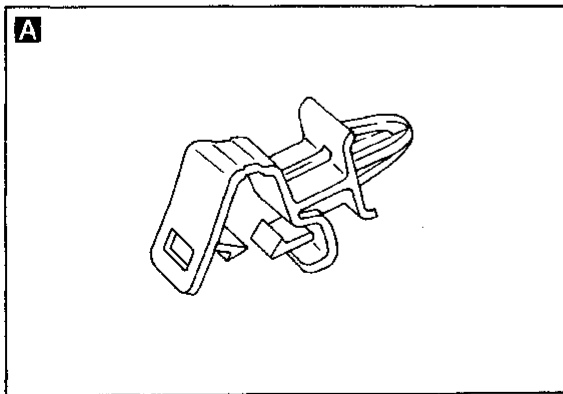
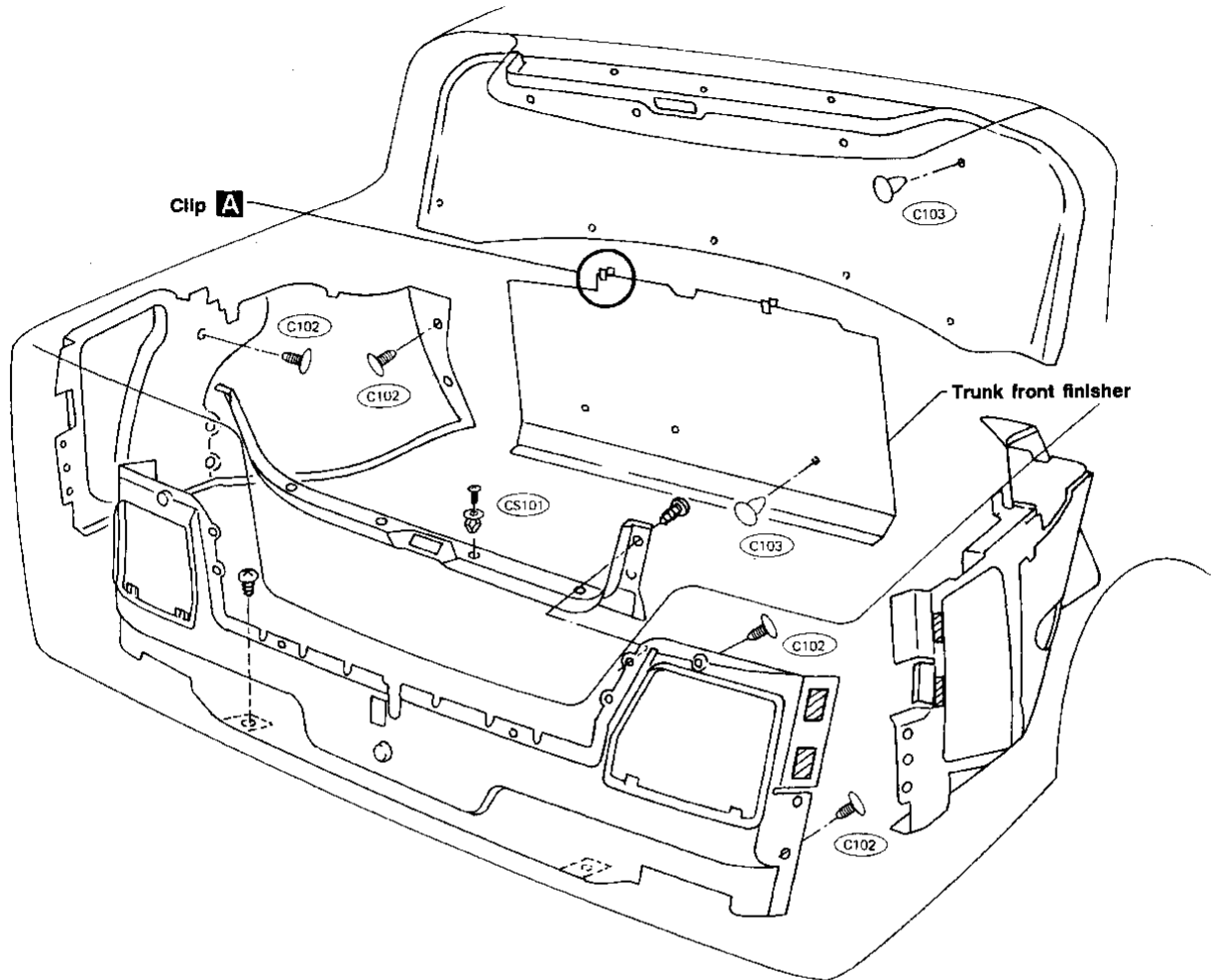

 : Velcro

GI

MA

EM

LC

EF &
EC

FE

CL

MT

AT

FA

RA

BR

ST

BF

HA

EL

IDX

INTERIOR AND EXTERIOR

Interior (Cont'd)

ROOF TRIM

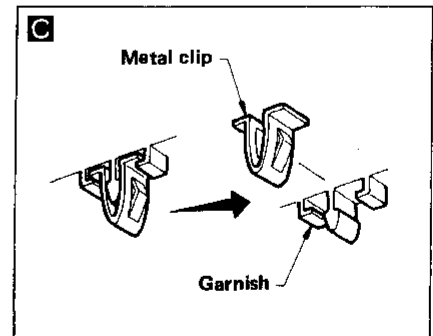
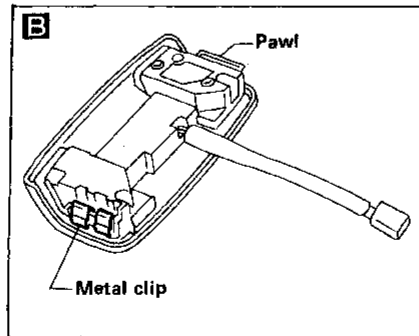
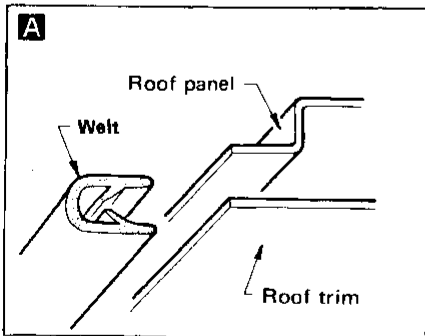
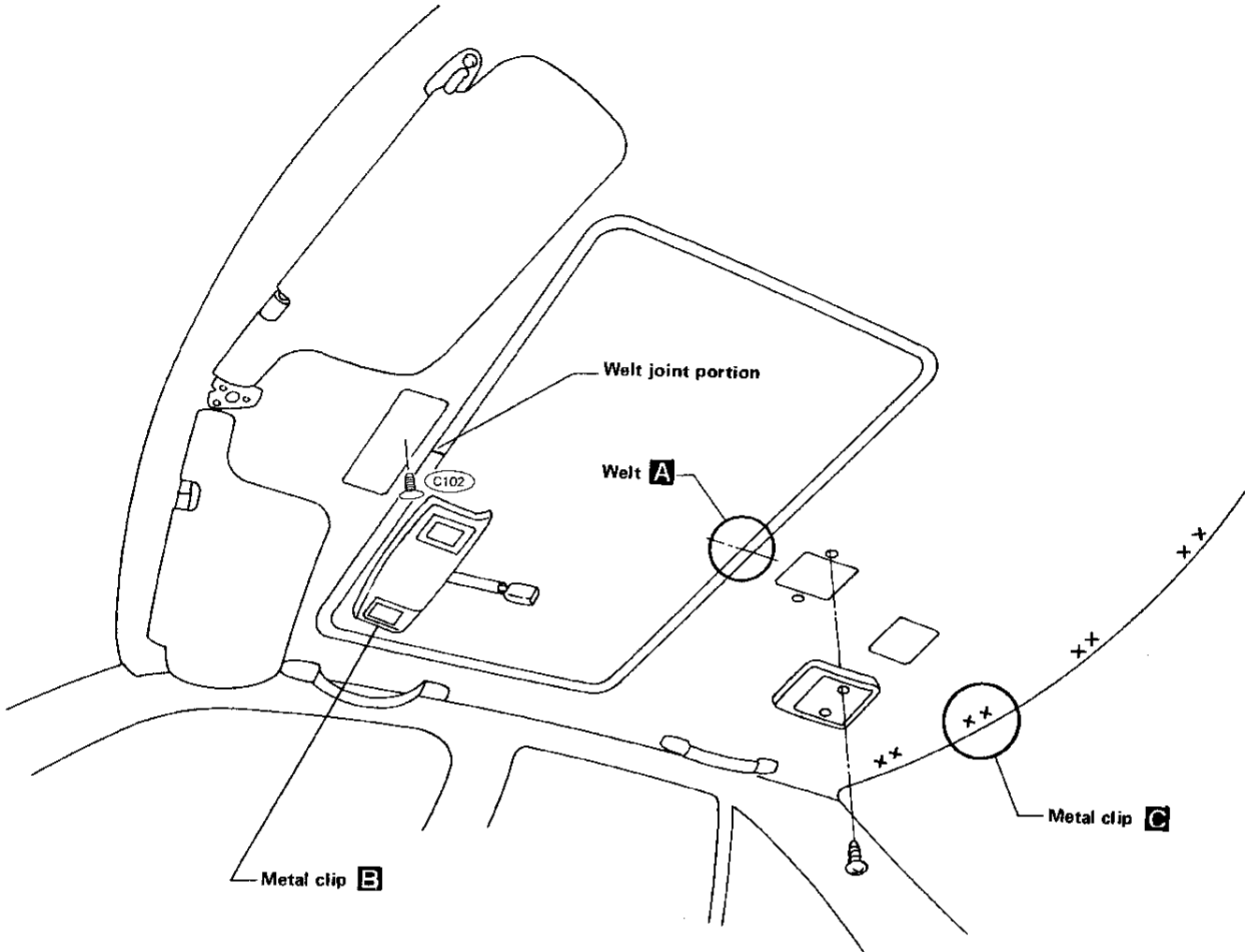

Exterior

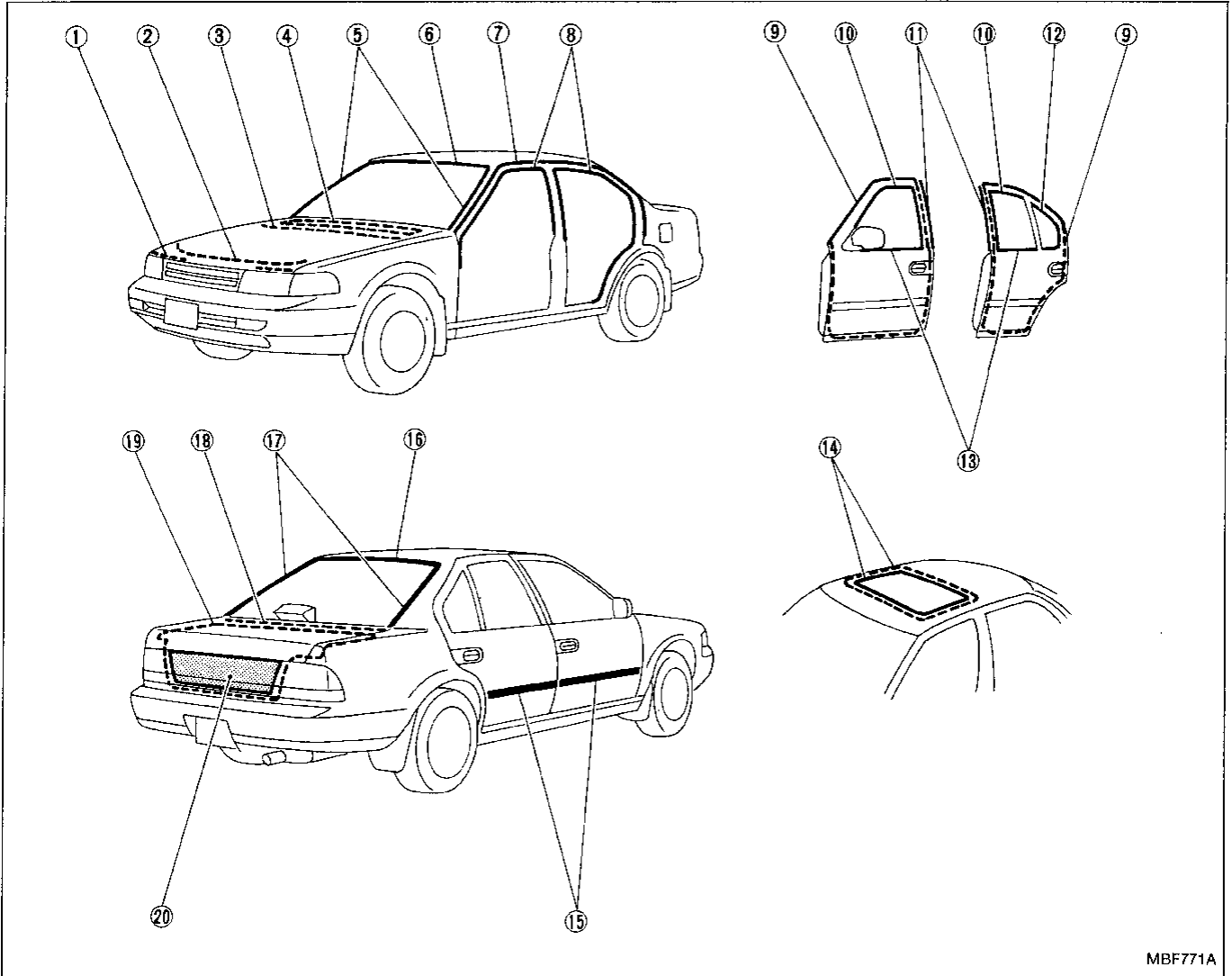

CI
MA
EM
LC
EF &
EC
FE
CL
MT
AT
FA
RA

MBF771A

① ② Hood molding and hood front seal

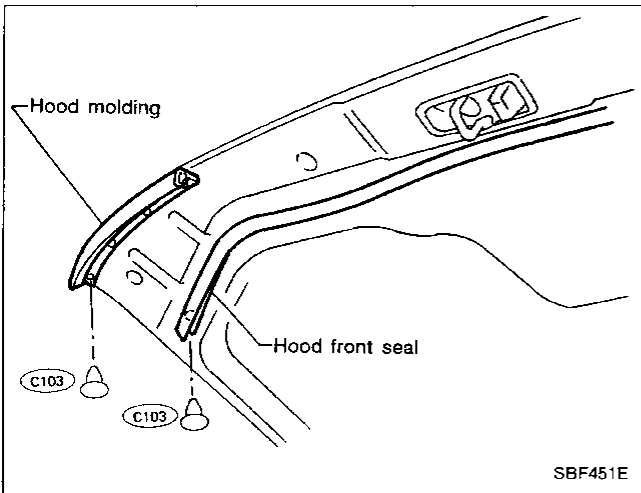

③ ④ Cowl top seal and cowl top grille

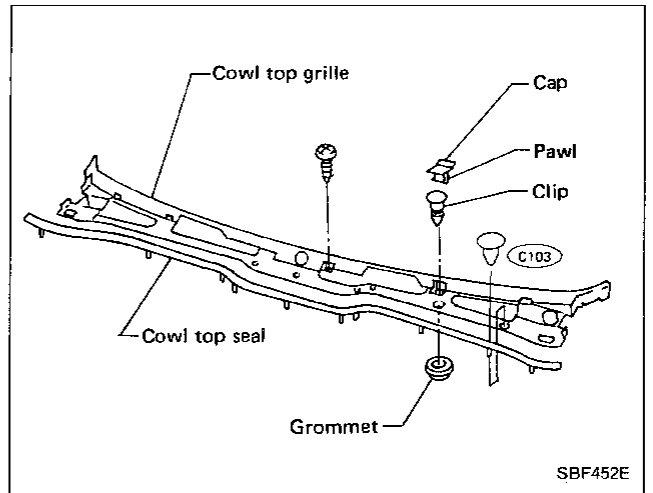

BR
ST
BF
HA
EL
DX

⑤ Windshield side molding
Mounted with screws.

INTERIOR AND EXTERIOR

Exterior (Cont'd)

⑥ Windshield upper molding

Method 1

Cut off top portion of molding and clean glass and panel surfaces.

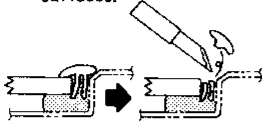

Apply sealant to top portion of molding.

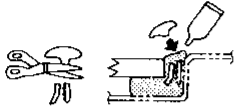

Cut off lower portion of new molding.



Finish well to give it a good appearance.

Method 2

1. Cut off sealant at glass end.
2. Clean the side on which panel was mounted.
3. Set molding fastener and apply sealant to body panel, and apply primer to molding and body.

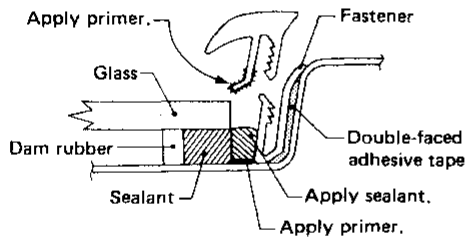

4. Install molding by aligning the molding mark located on center with vehicle center. Be sure to install tightly so that there is no gap around the corner.

SBF161E

⑦ Drip weatherstrip

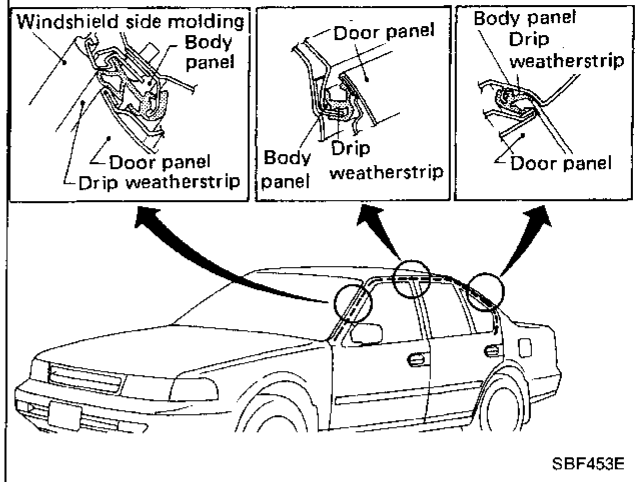

⑧ Body side welt

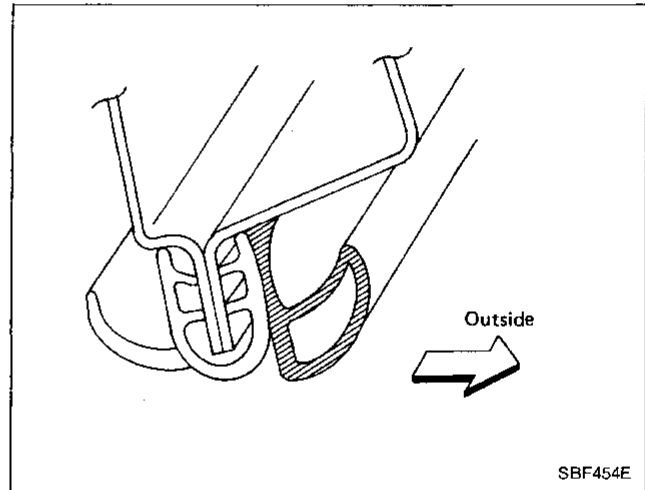

⑨ Door weatherstrip

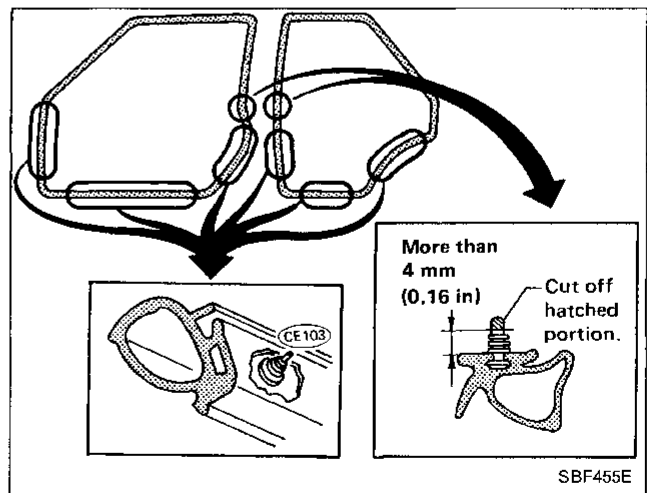

INTERIOR AND EXTERIOR

Exterior (Cont'd)

10 Door sash molding

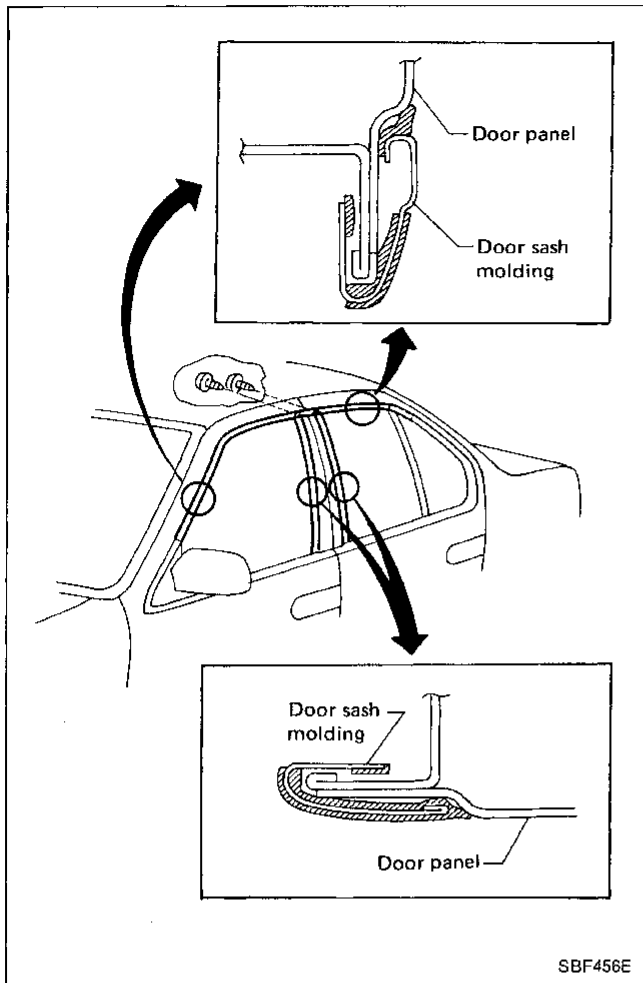

12 Rear door corner molding

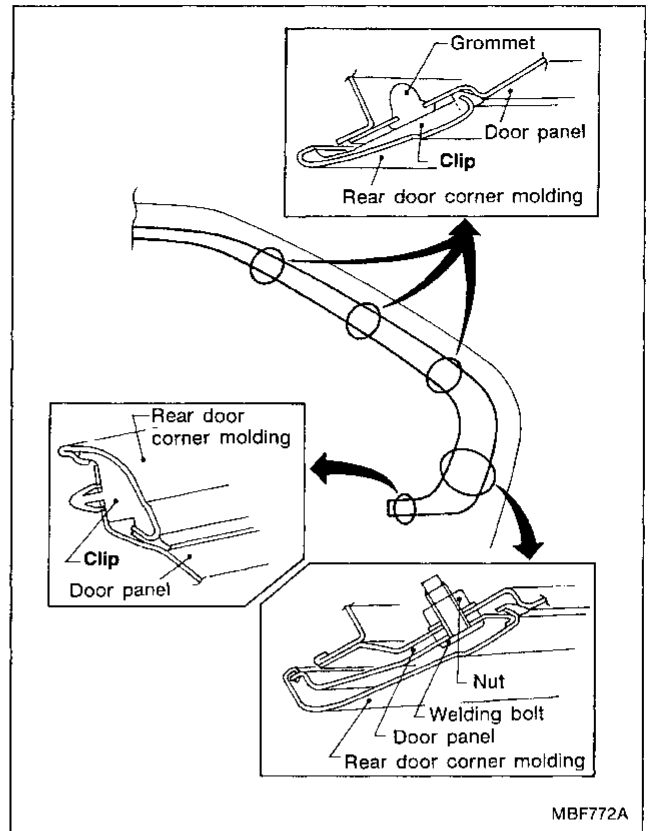

13 Door outside molding

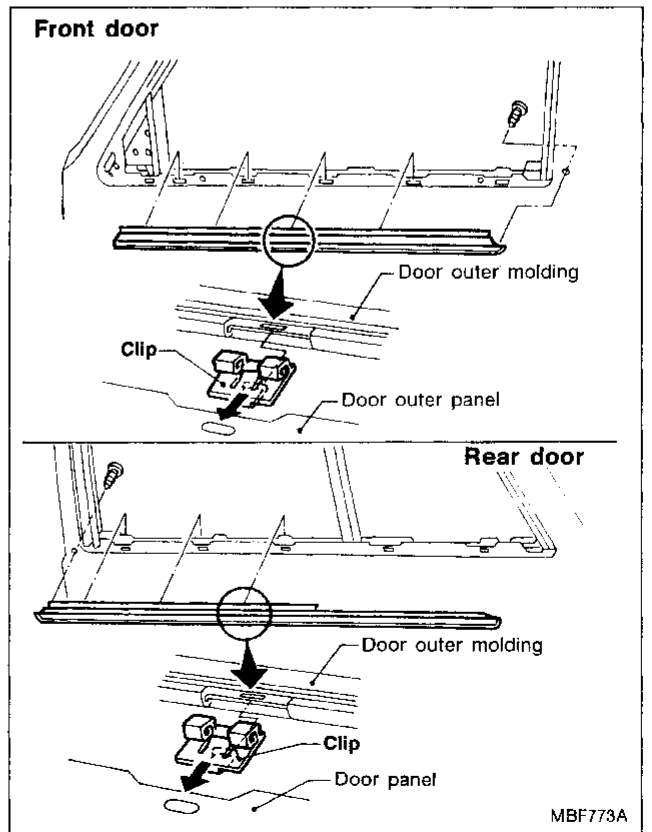

11 Front door parting seal

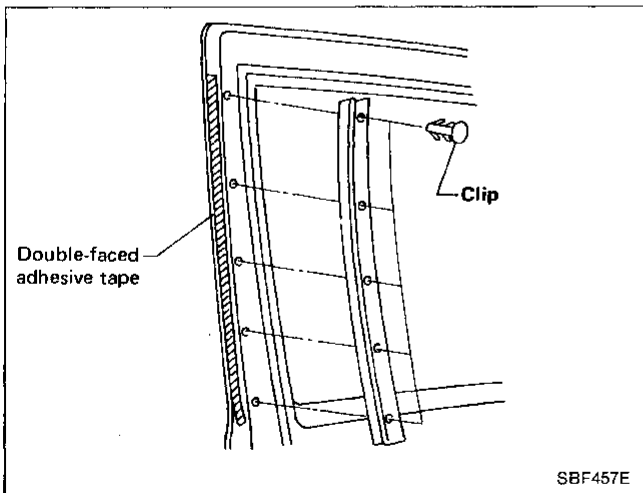

GI

MA

EM

LC

EF &
EC

FE

CL

MT

AT

FA

RA

BR

ST

BF

HA

EL

IDX

INTERIOR AND EXTERIOR

Exterior (Cont'd)

14 Sun roof frame weatherstrip and sun roof lid weatherstrip

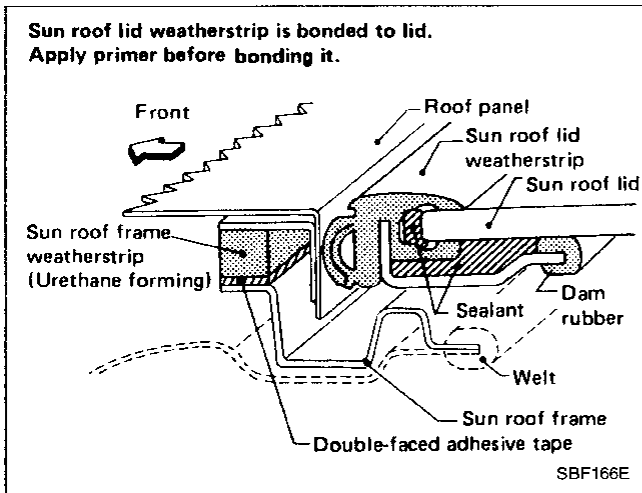

16 17 Rear window upper molding and side molding

Basically the same as windshield upper molding.
Refer to 6 Windshield upper molding.

18 Rear window lower molding

Mounted with screws.

19 Trunk lid weatherstrip

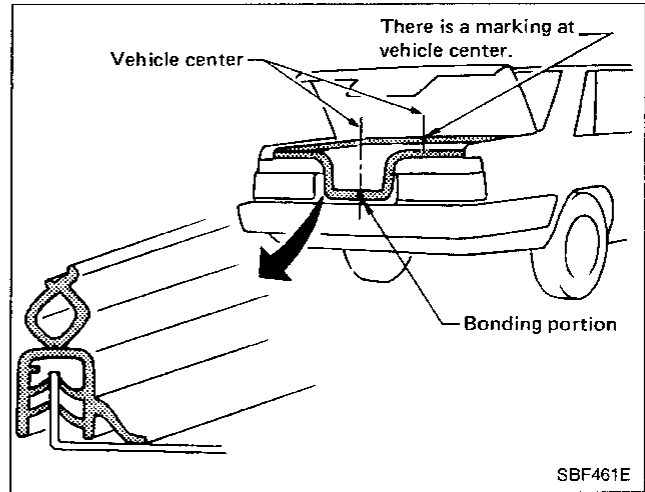

15 Side guard molding

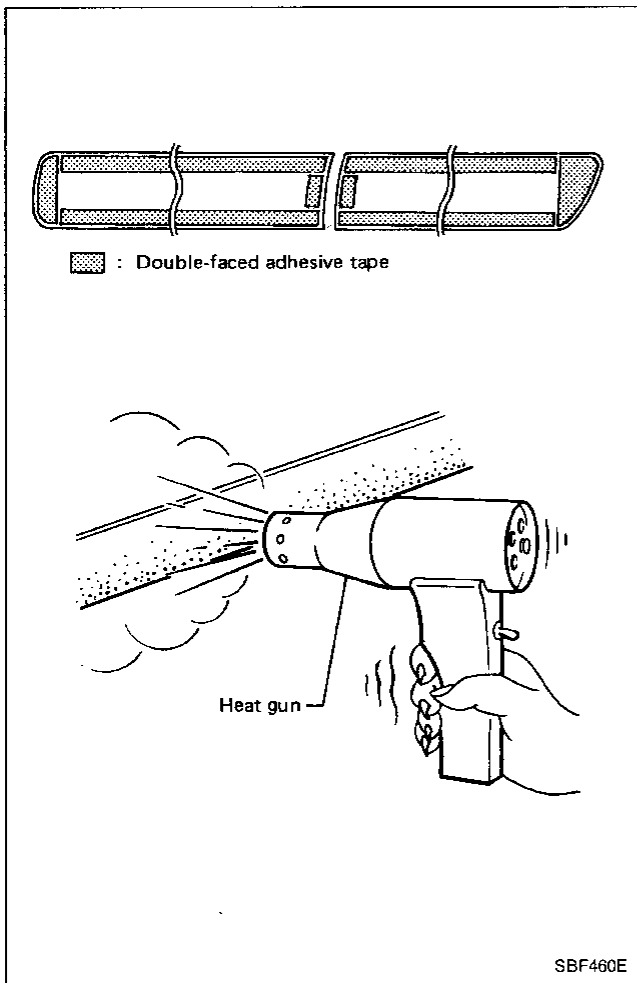

20 Trunk lid finisher

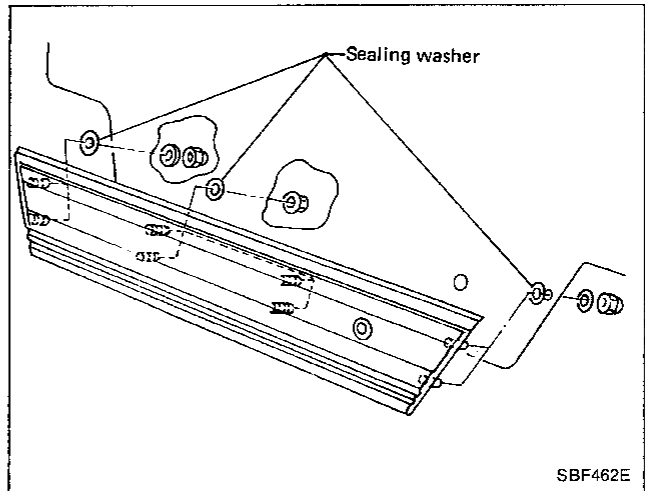

SEAT

- When removing or installing the seat trim, carefully handle it to keep dirt out and avoid damage.

Front Seat

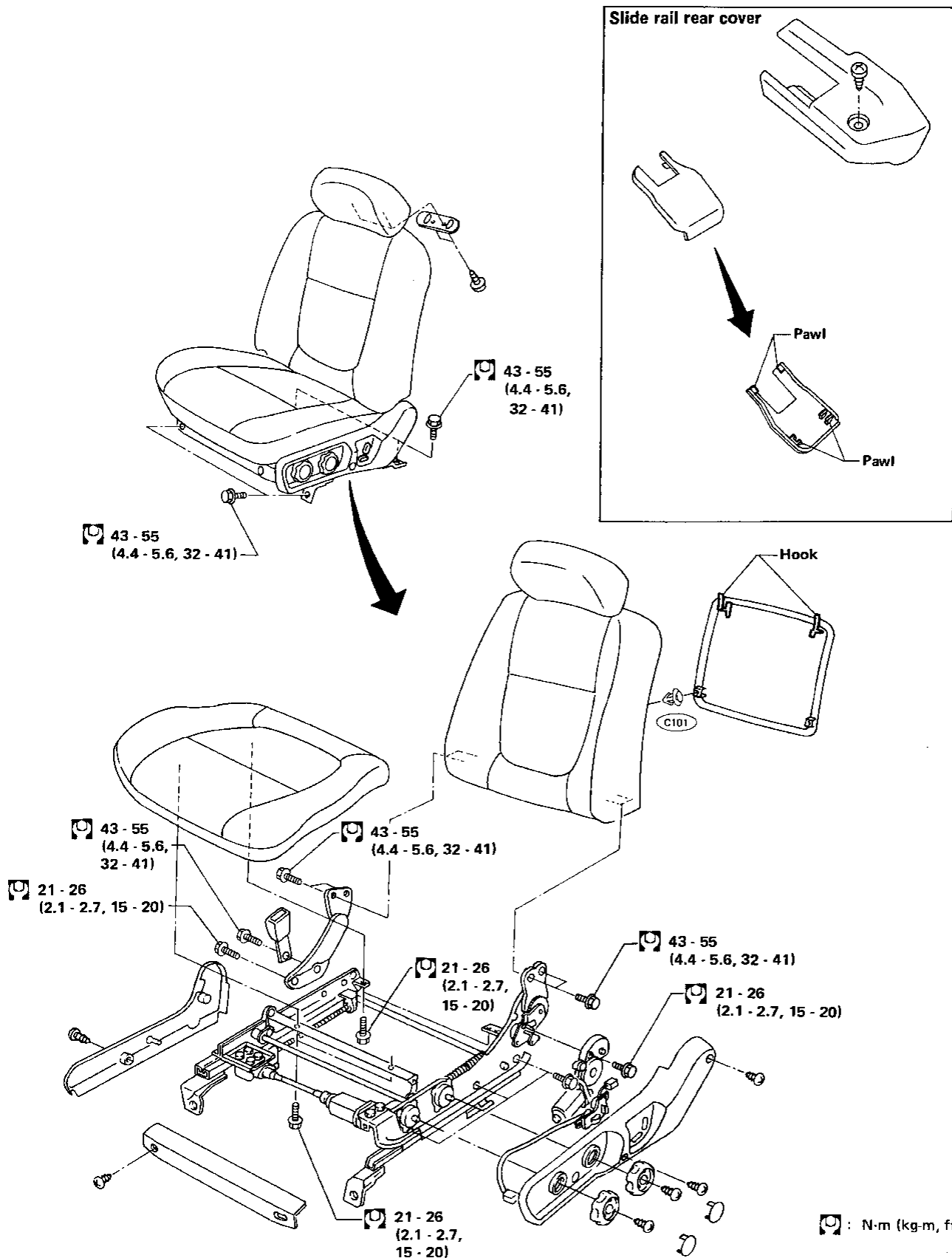

GI
MA
EM
LC
EF &
EC
FE
CL
MT
AT
FA
RA
BR
ST
BF
HA
EL
IDX

SEAT

Rear Seat

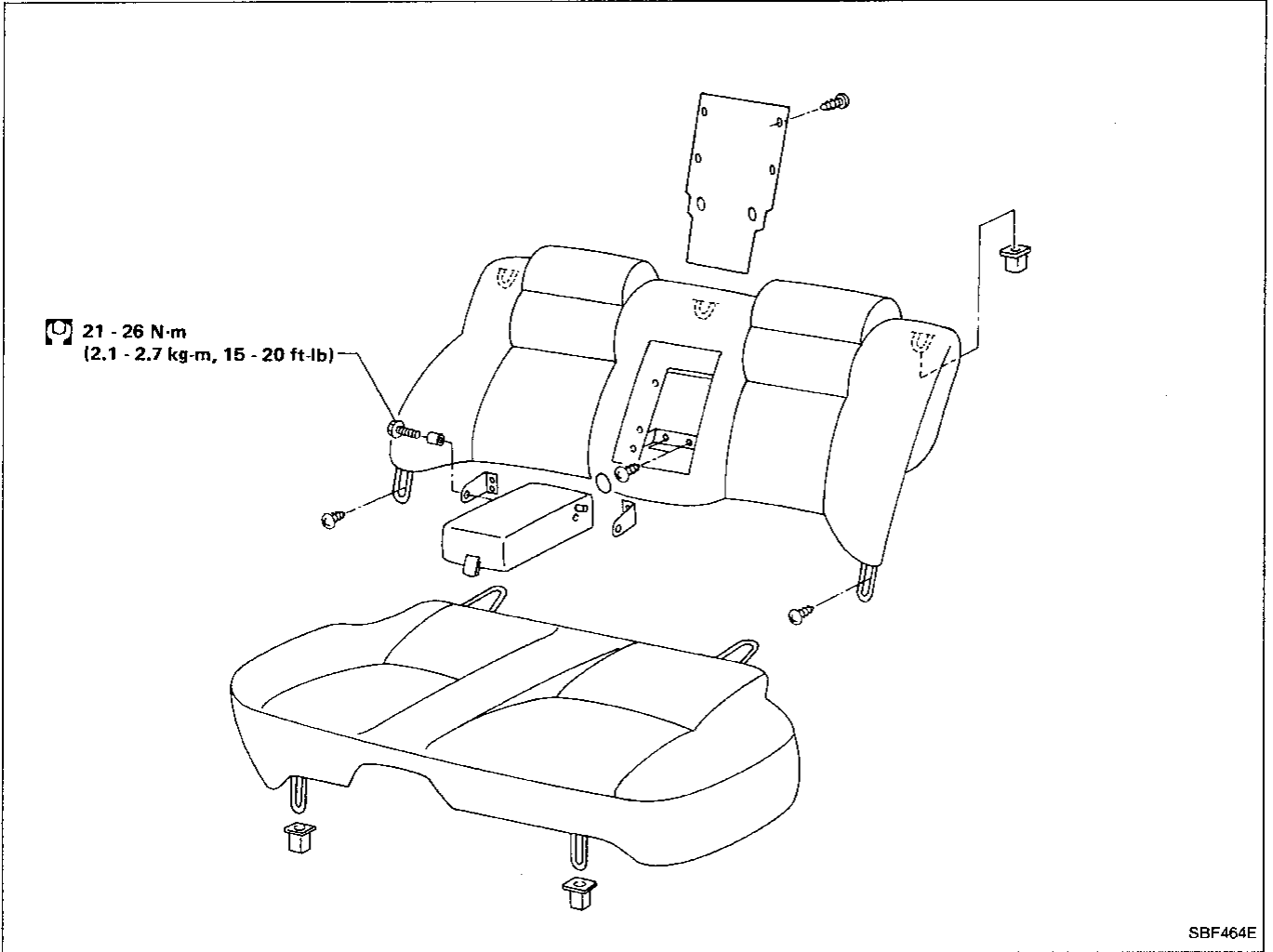

AUTOMATIC SEAT BELT SYSTEM

Unit Location

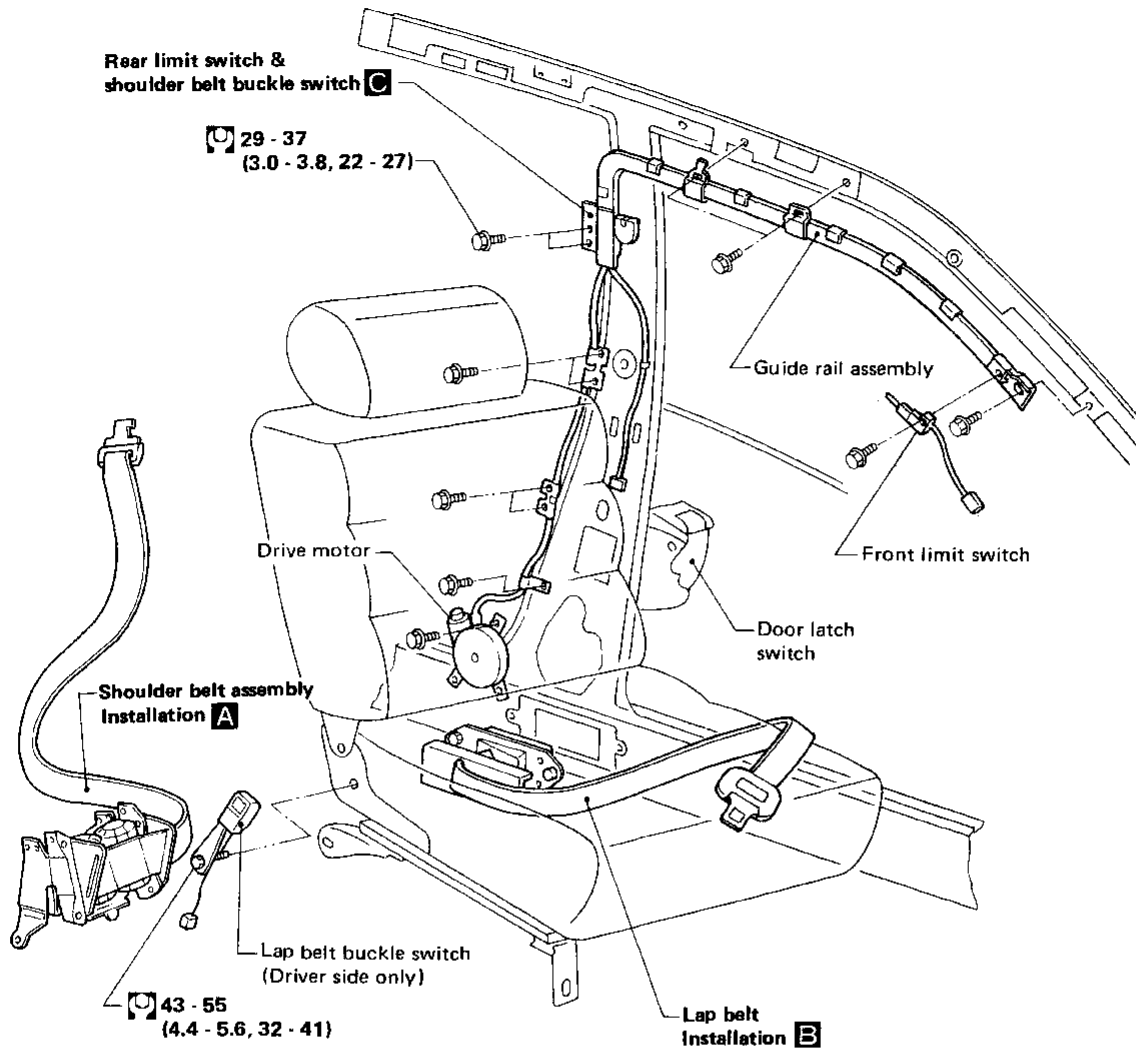

Control unit

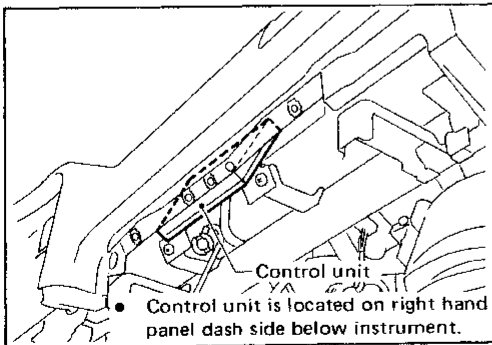

: N-m (kg-m, ft-lb)

AUTOMATIC SEAT BELT SYSTEM

Unit Location (Cont'd)

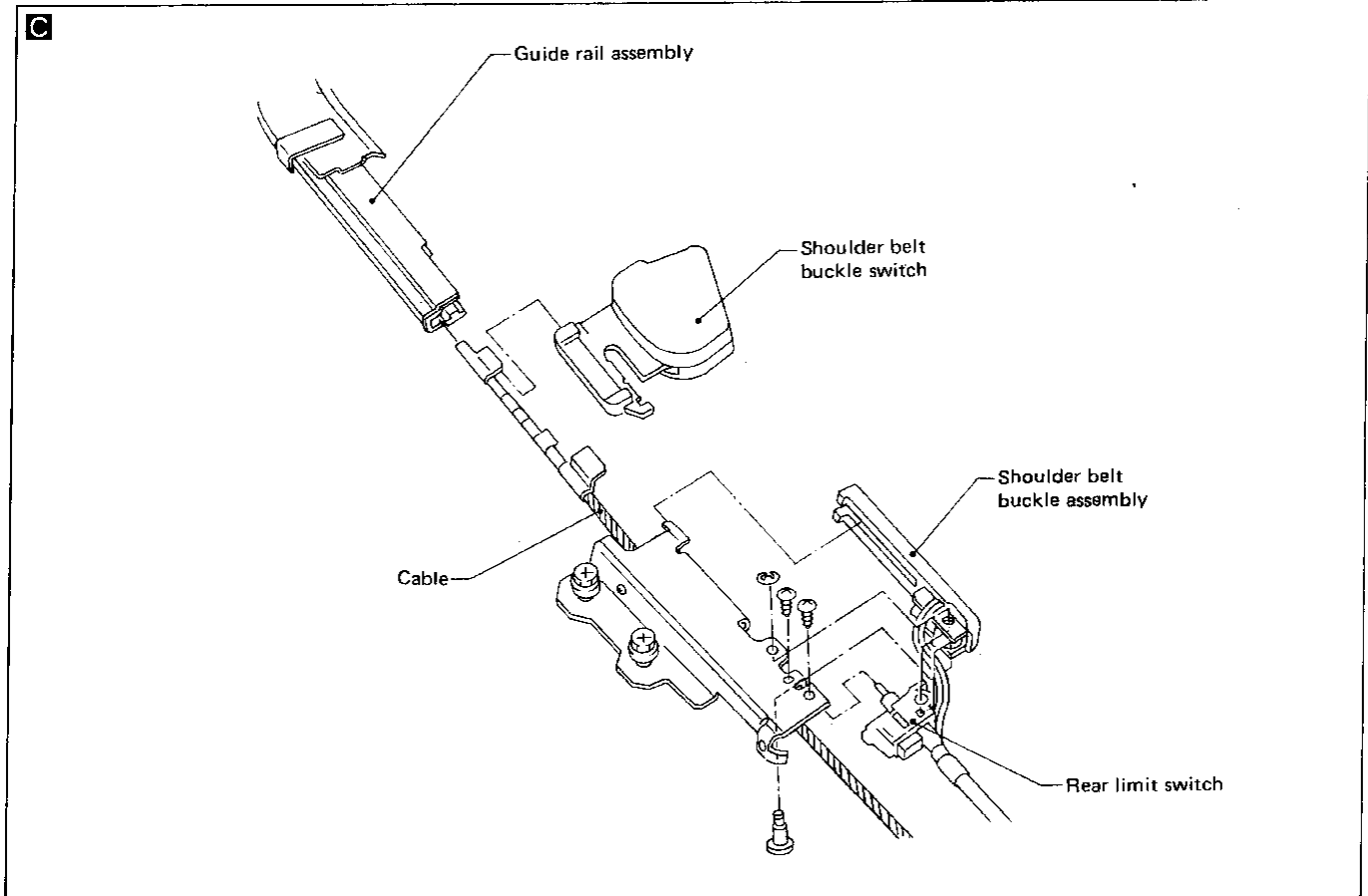
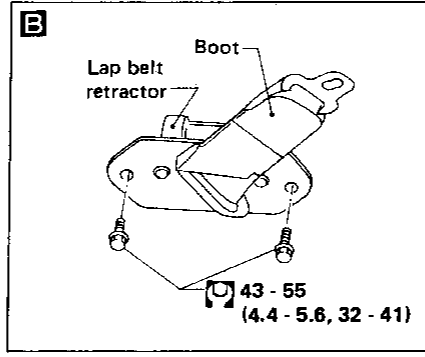
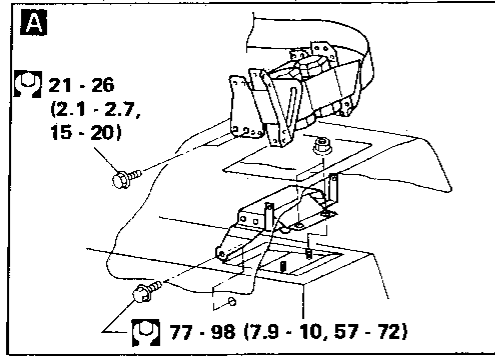

GI

MA

EM

LC

EF &
EC

FE

CL

WF

AT

FA

RA

BR

ST

BF

HA

EL

IDX

AUTOMATIC SEAT BELT SYSTEM

Wiring Diagram

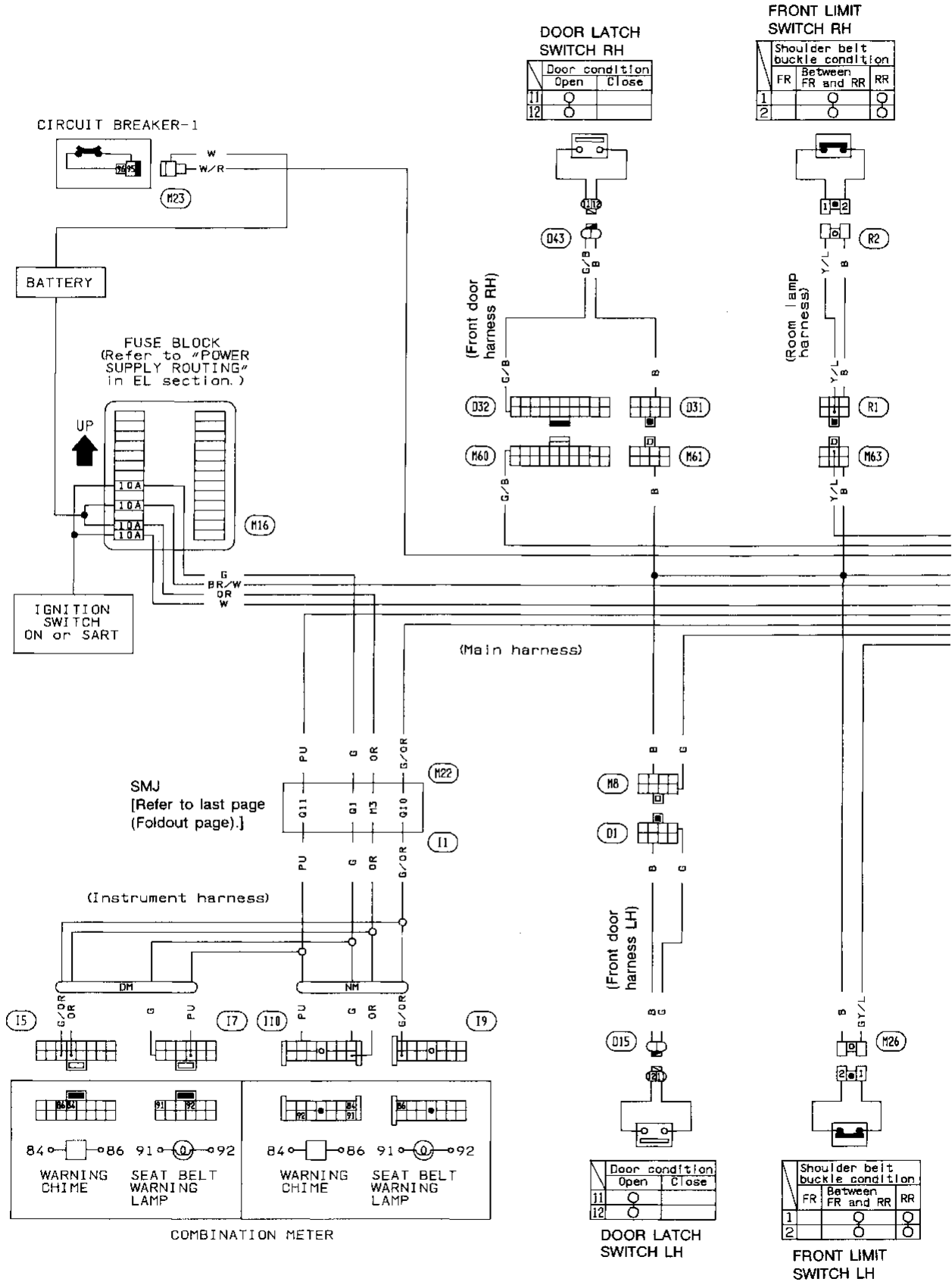

AUTOMATIC SEAT BELT SYSTEM

Wiring Diagram (Cont'd)

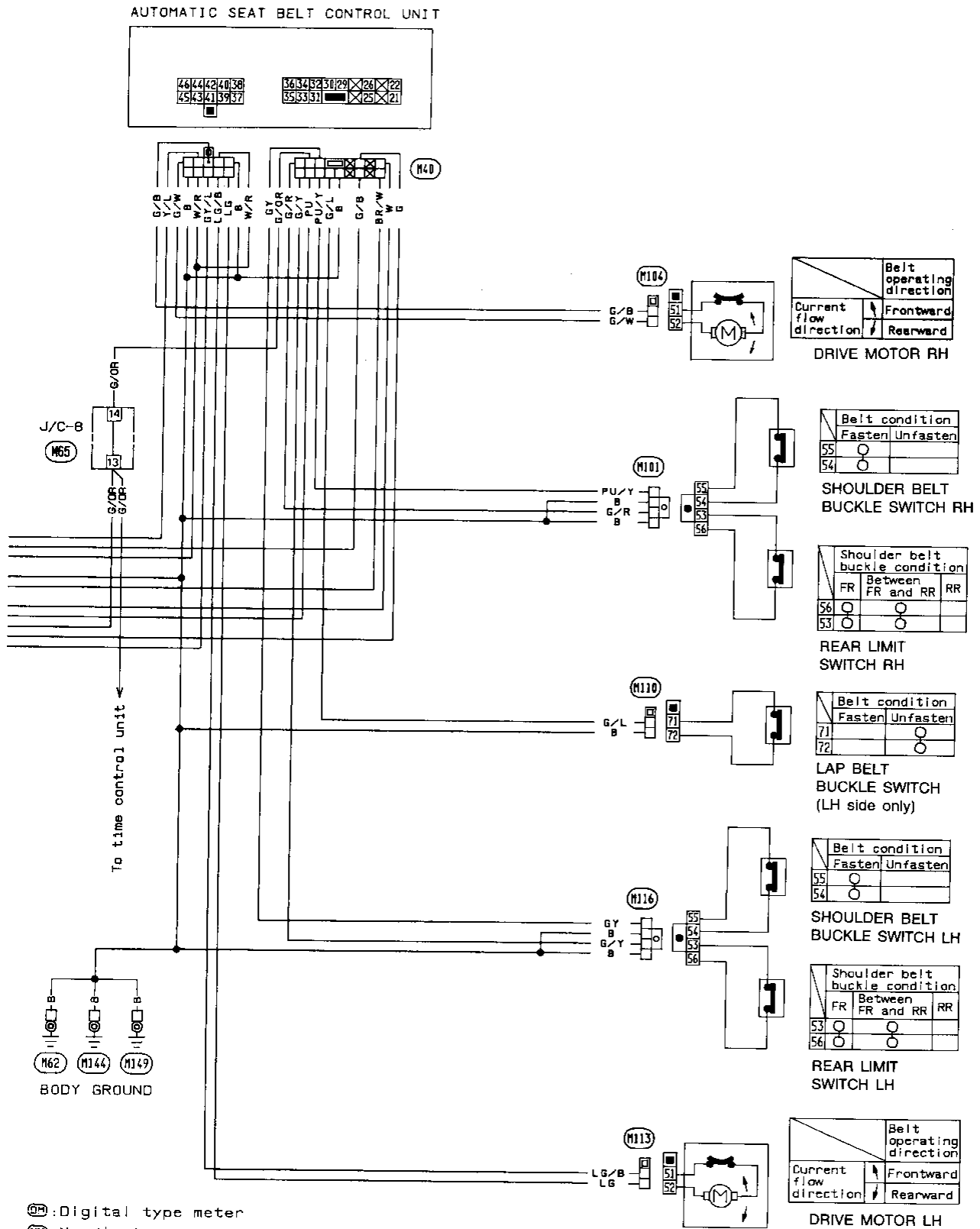

GI
MA
EM
LC
EF & EC
FE
CL
MT
AT
FA
RA
BR
ST
BF
HA
EL
IDX

AUTOMATIC SEAT BELT SYSTEM

Description

FUNCTION

Shoulder belt buckle is mainly operated while ignition switch is "ON".

Condition (A): Ignition switch is "ON".

When door is opened, shoulder belt buckle is moved forward and when door is closed, buckle is moved rearward.

Condition (B): Ignition switch is "OFF".

When door is opened, shoulder belt buckle is moved forward. When door is closed, buckle will remain in this position.

(Voltage of output signal is approximate value.)

Input signal	Ignition switch	OFF	OFF	ON	ON	ON	ON	ON	ON	ON	ON	ON	OFF	OFF	OFF	OFF	OFF
	Door latch switch	OFF	ON	OFF	OFF	OFF	ON	ON	ON	OFF	OFF	OFF	OFF	ON	ON	ON	OFF
	Front limit switch	OFF	OFF	OFF	ON	ON	ON	ON	OFF	OFF	ON	ON	ON	ON	ON	OFF	OFF
	Rear limit switch	ON	ON	ON	ON	OFF	OFF	ON	ON	ON	ON	OFF	OFF	OFF	ON	ON	ON
Output signal	Drive motor power source for frontward operation	0V	0V	0V	0V	0V	12V	12V	0V	0V	0V	0V	0V	12V	12V	0V	0V
	Drive motor power source for rearward operation	0V	0V	12V	12V	0V	0V	0V	0V	12V	12V	0V	0V	0V	0V	0V	0V
Shoulder belt buckle	Function	Stop	Stop	Start to move	Moving	Stop	Start to move	Moving	Stop	Start to move	Moving	Stop	Stop	Start to move	Moving	Stop	Stop
	Position	Front	Front	Front	Between Front & Rear	Rear	Rear	Between Front & Rear	Front	Front	Between Front & Rear	Rear	Rear	Rear	Between Front & Rear	Front	Front

TIMER (Ignition switch either "ON" or "OFF")

If limit switch does not operate (when accomplishing frontward operation, front limit switch can not be turned "OFF" or when accomplishing rearward operation, rear limit switch can not be turned "OFF"), control unit will continue to supply power to drive motor for 15 seconds.

QUICK WARNING (Ignition switch "ON")

If front limit switch is not turned "OFF" after accomplishing frontward operation, control unit will stop supplying power 15 seconds later and warning lamp will flash and chime will operate rapidly for approximately 6 seconds.

REAR LOCK (Fail safe operation)

If quick warning functions twice successively while ignition switch is "ON", shoulder belt buckle will move to rear position and will remain in the rear position. This function is canceled when the ignition switch is "OFF".

Contents

Symptom Chart	BF-49
Preliminary Check	BF-50
Main Power Supply and Ground Circuit Check	BF-52
Harness Layout	BF-53
Circuit Diagram for Quick Pinpoint Check	BF-55
Diagnostic Procedure 1	
(Check motor circuit and stop signals.)	BF-56
Diagnostic Procedure 2	
(Check door switch circuit.)	BF-59
Diagnostic Procedure 3	
(Check front limit switch circuit.)	BF-60
Diagnostic Procedure 4	
(Check rear limit switch circuit.)	BF-61
Diagnostic Procedure 5	
(Check shoulder belt switch circuit.)	BF-63
Diagnostic Procedure 6	
(Check lap belt switch circuit.)	BF-64
Diagnostic Procedure 7	
(Check warning chime circuit.)	BF-66
Diagnostic Procedure 8	
(Check warning lamp circuit.)	BF-67
Electrical Components Inspection	BF-67

Since left and right component parts are basically the same, harness layout and methods for electrical components inspection are shown for one side only.

For those methods enclosed by double rectangles, component parts on both sides must be checked.

AUTOMATIC SEAT BELT SYSTEM — Trouble Diagnoses

Symptom Chart

Procedure	Reference page	SYMPTOM							
Electrical Components Inspection	RH side	BF-68	Motor	○	○				
		BF-68	Shoulder belt buckle switch	○				○	
		BF-68	Door latch switch	○		○	○		
		BF-68	Rear limit switch	○	○	○		○	
		BF-67	Front limit switch	○	○		○	○	
	LH side	BF-68	Lap belt buckle switch	○					○
		BF-68	Motor	○	○				
		BF-68	Shoulder belt buckle switch	○				○	
		BF-68	Door latch switch	○		○	○		
		BF-68	Rear limit switch	○	○	○		○	
		BF-67	Front limit switch	○	○		○	○	
	—	Warning chime	○					○	
	—	Warning lamp	○					○	
	Diagnostic Procedure	BF-67	Procedure 8						○
BF-66		Procedure 7						○	
BF-64		Procedure 6						○	
BF-63		Procedure 5						○	
BF-61		Procedure 4	○	○	○			○	
BF-60		Procedure 3	○	○		○		○	
BF-59		Procedure 2			○	○			
BF-56		Procedure 1	○	○					
Main Power Supply and Ground Circuit Check	BF-52	Procedure 2		○					
	BF-52	Procedure 1	○						
Preliminary Check	BF-51	Procedure 2						○	
	BF-50	Procedure 1		○	○	○			
			No operation has made. (No warning indicated and no buckles movement performed)		Shoulder belt buckle in LH or RH side does not move.	Shoulder belt buckle moves forwards only. (not rearwards)	Shoulder belt buckle moves rearwards only. (not frontwards)	Warnings indicate incorrectly or do not function.	Quick warning operates.

CI
 MA
 EM
 LC
 EF & EC
 FE
 CL
 MT
 AT
 FA
 RA
 BR
 ST
BF
 HA
 EL
 IX

Preliminary Check

PROCEDURE 1

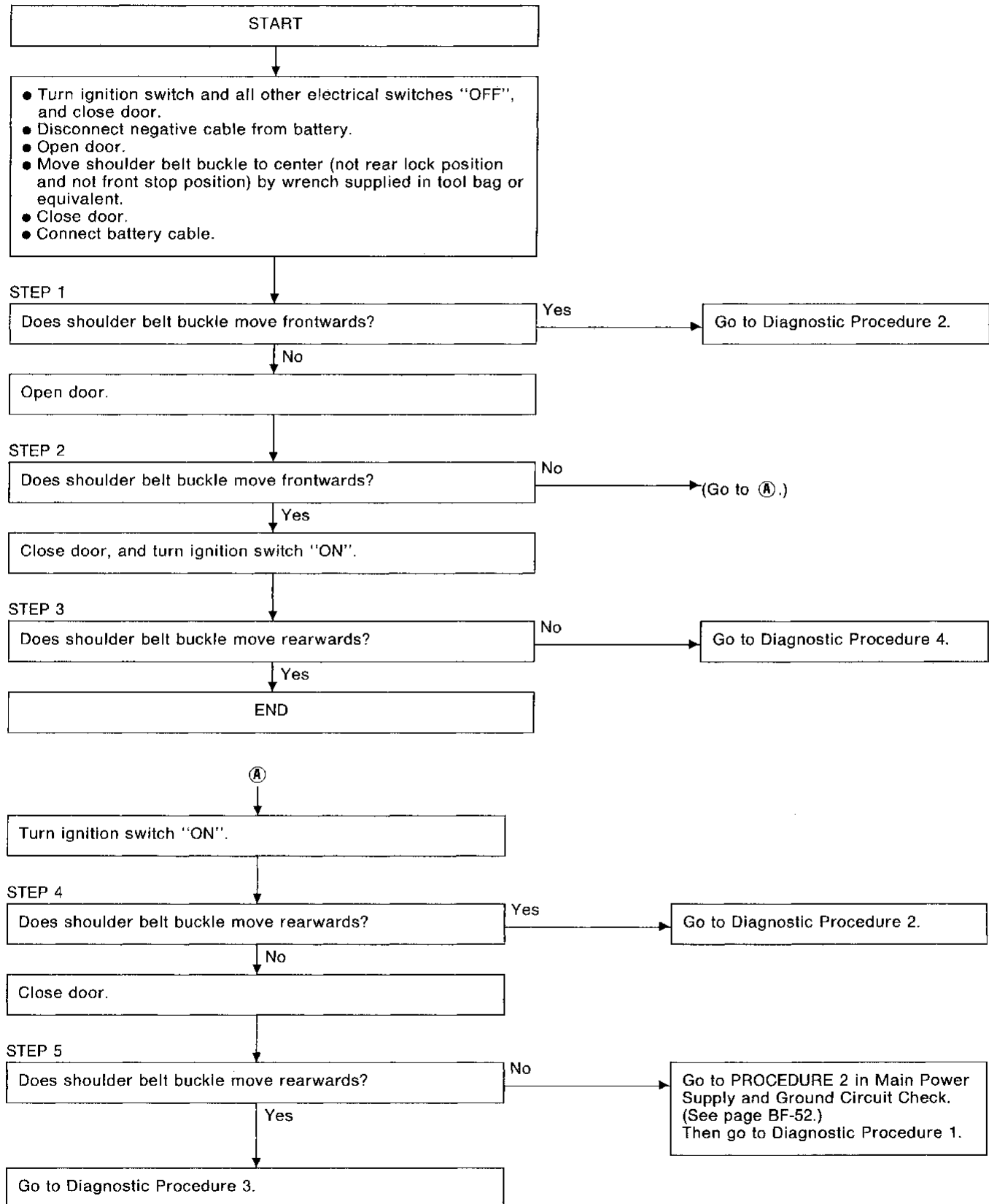

AUTOMATIC SEAT BELT SYSTEM — Trouble Diagnoses

Preliminary Check (Cont'd)

PROCEDURE 2

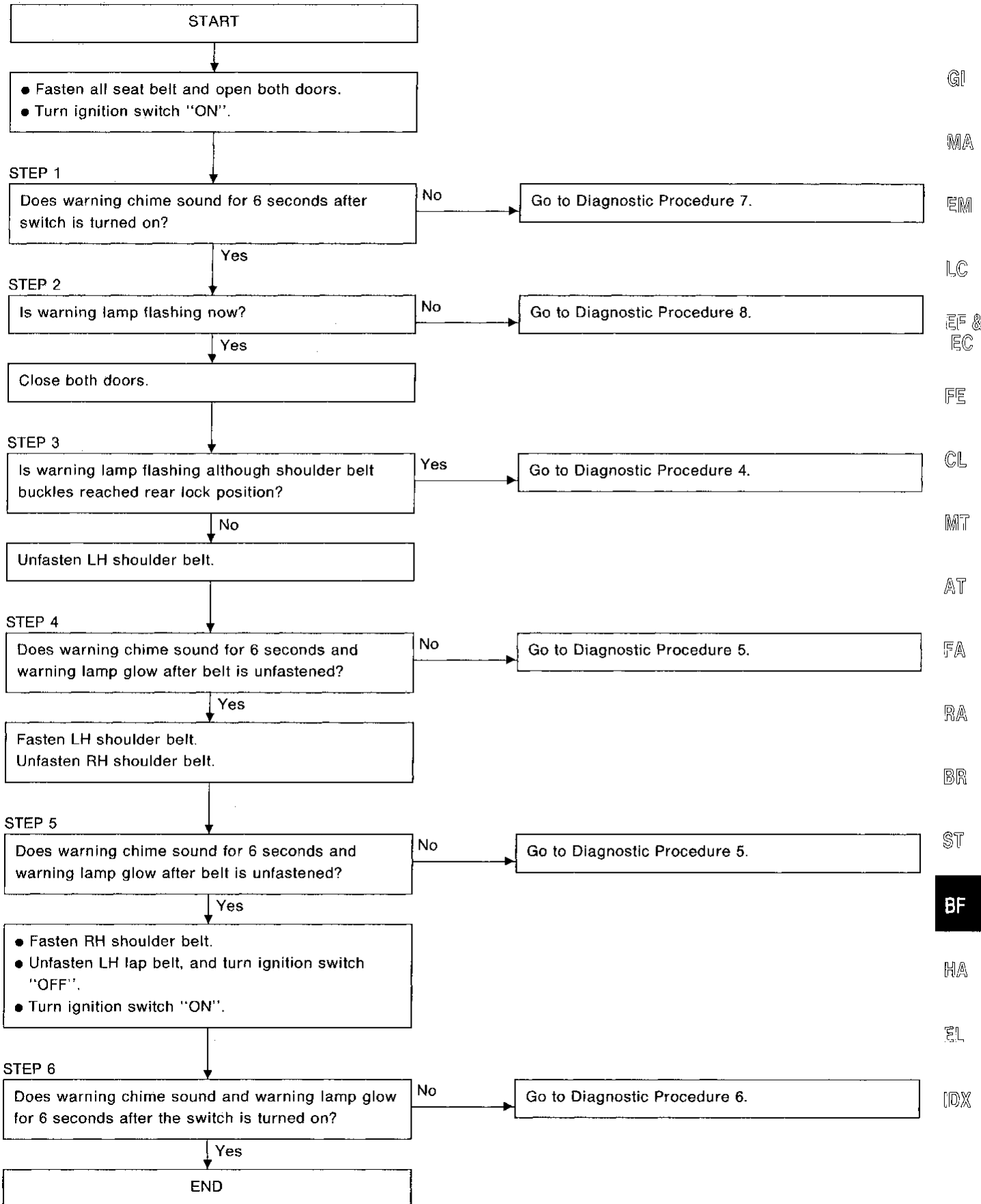

GI
 MA
 EM
 LC
 EF & EC
 FE
 CL
 MT
 AT
 FA
 RA
 BR
 ST
BF
 HA
 EL
 IDX

AUTOMATIC SEAT BELT SYSTEM — Trouble Diagnoses

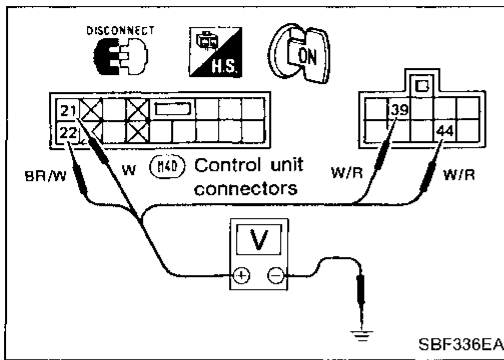

Main Power Supply and Ground Circuit Check

PROCEDURE 1

Main power supply

Terminals	Battery voltage existence condition	
	Ignition switch "ON"	Other than ignition switch "ON"
②1 - Ground	Yes	No
②2 - Ground	Yes	Yes
③9 - Ground	Yes	Yes
④4 - Ground	Yes	Yes

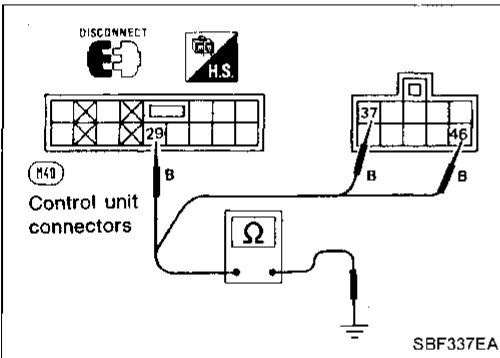

Ground circuit

Terminals	Continuity
②9 - Ground	Yes
③7 - Ground	Yes
④6 - Ground	Yes

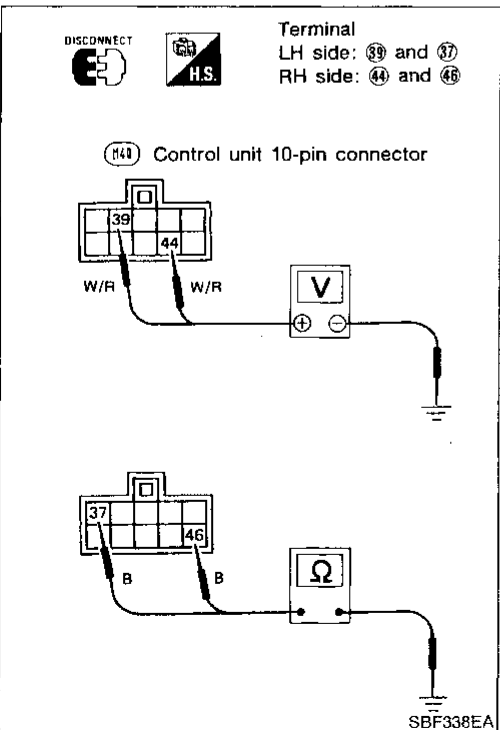

PROCEDURE 2

Power supply for motor drive

	Terminals	Battery voltage existence
LH side	③9 - Ground	Yes
RH side	④4 - Ground	Yes

Ground circuit for motor drive

	Terminals	Continuity
LH side	③7 - Ground	Yes
RH side	④6 - Ground	Yes

Harness Layout

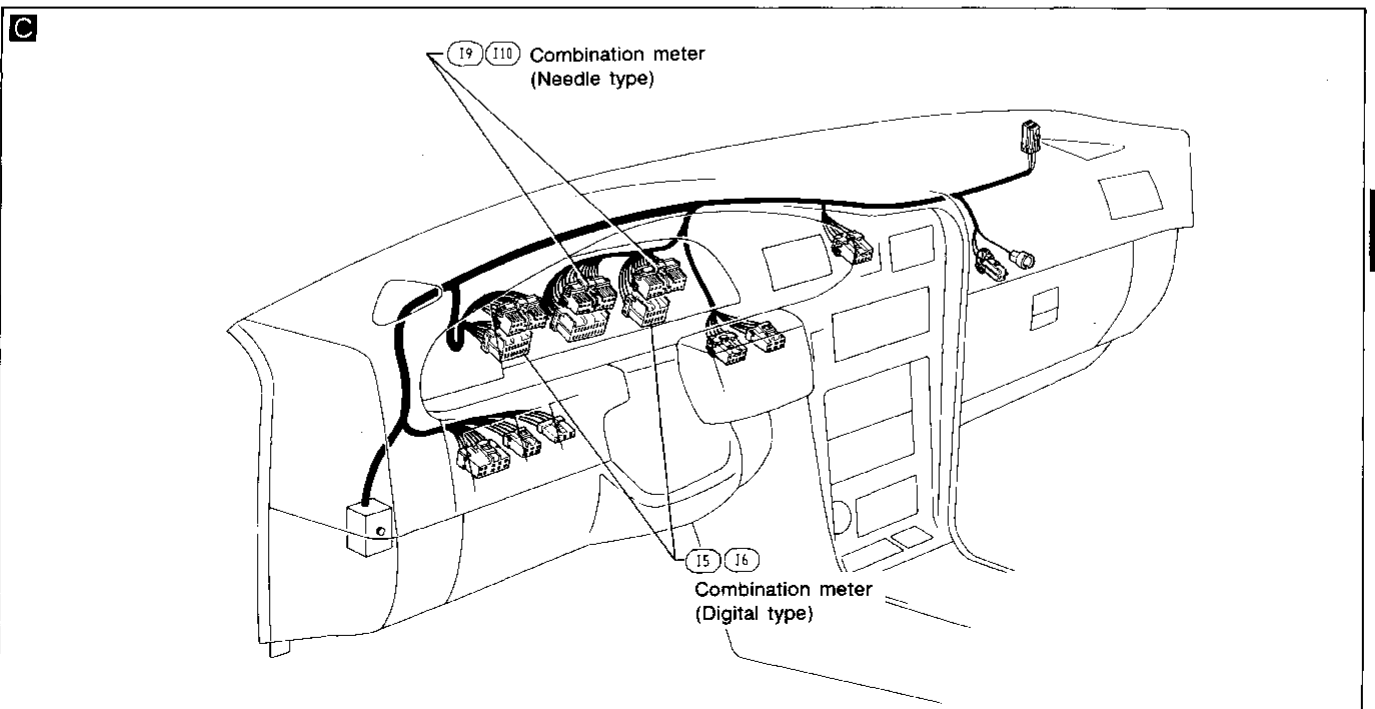
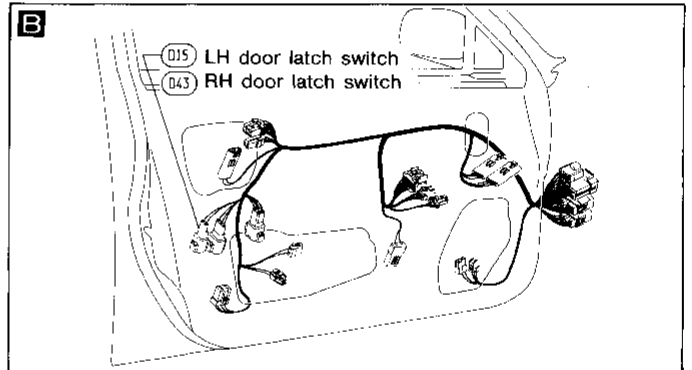
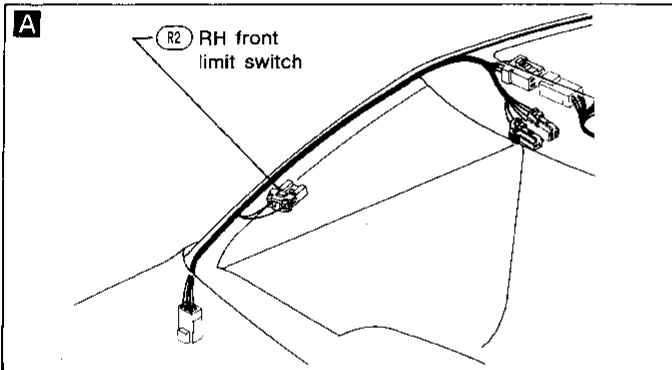
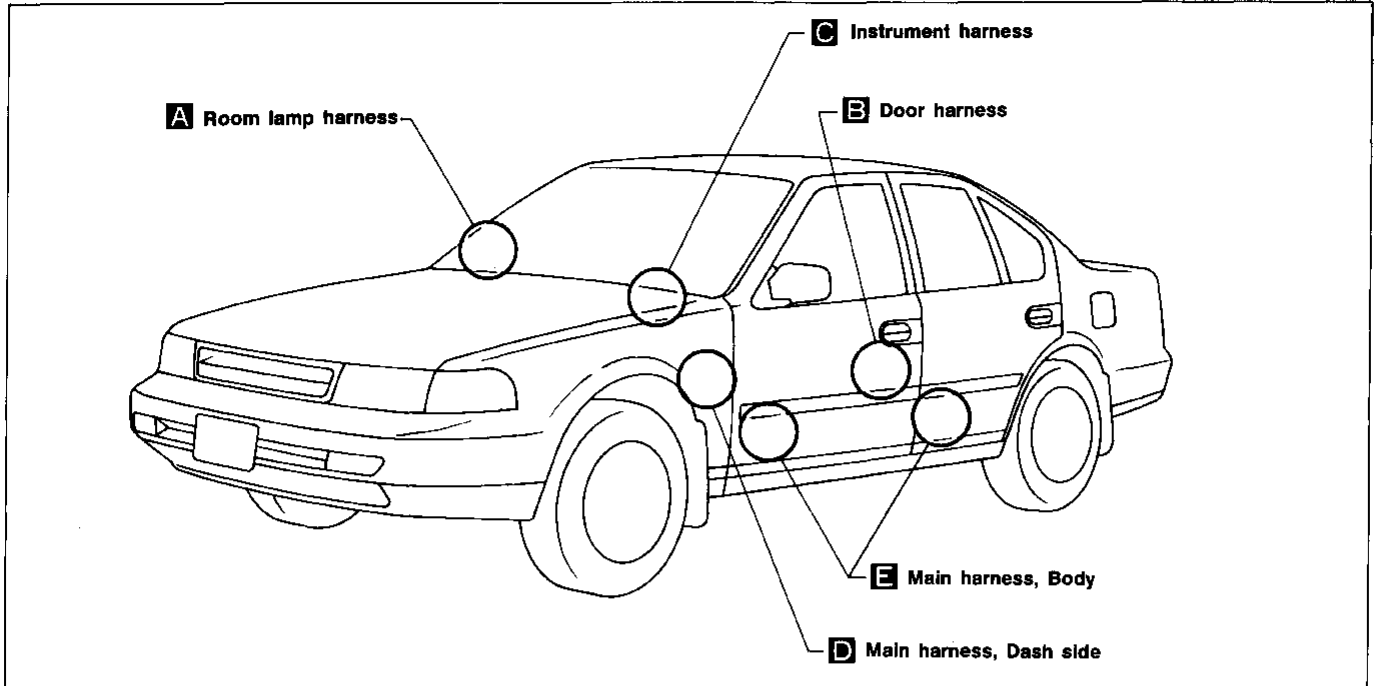

GI
MA
EM
LC
EF &
EC
FE
CL
MT
AT
FA
RA
BR
ST
BF
HA
EL
IDX

AUTOMATIC SEAT BELT SYSTEM — Trouble Diagnoses

Harness Layout (Cont'd)

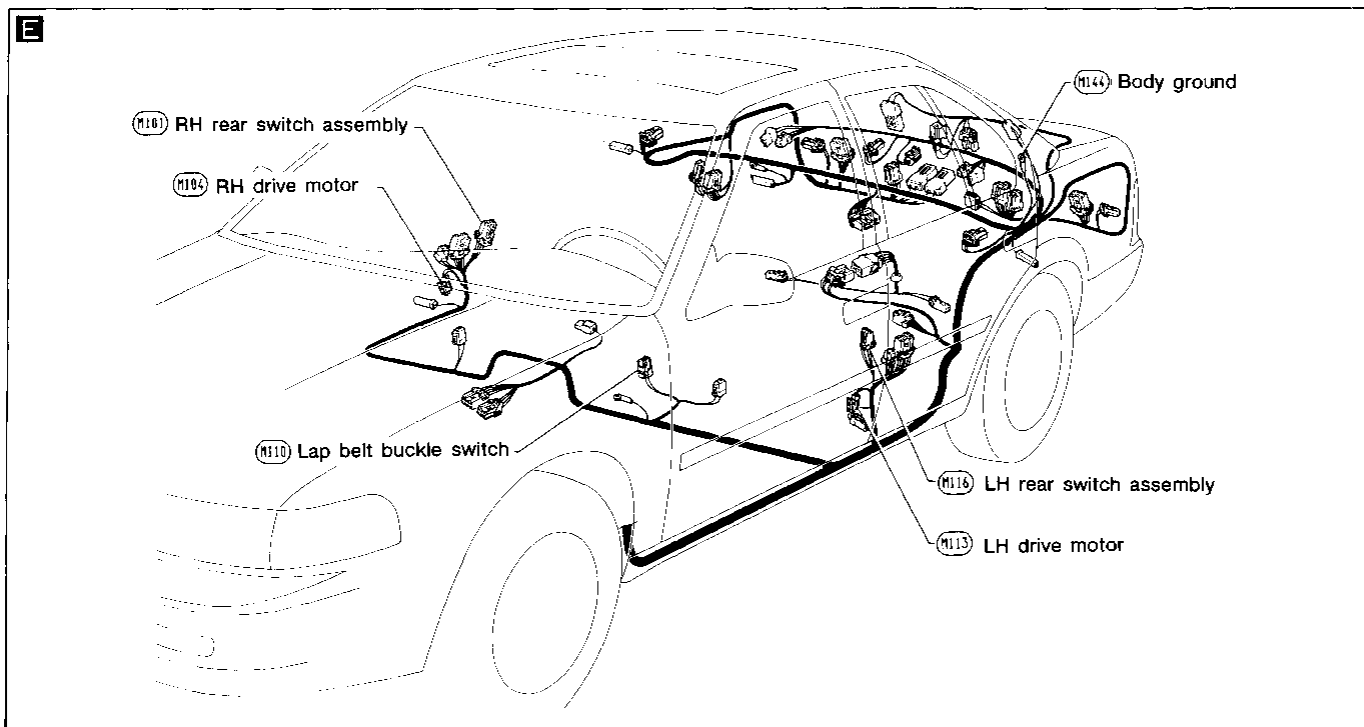
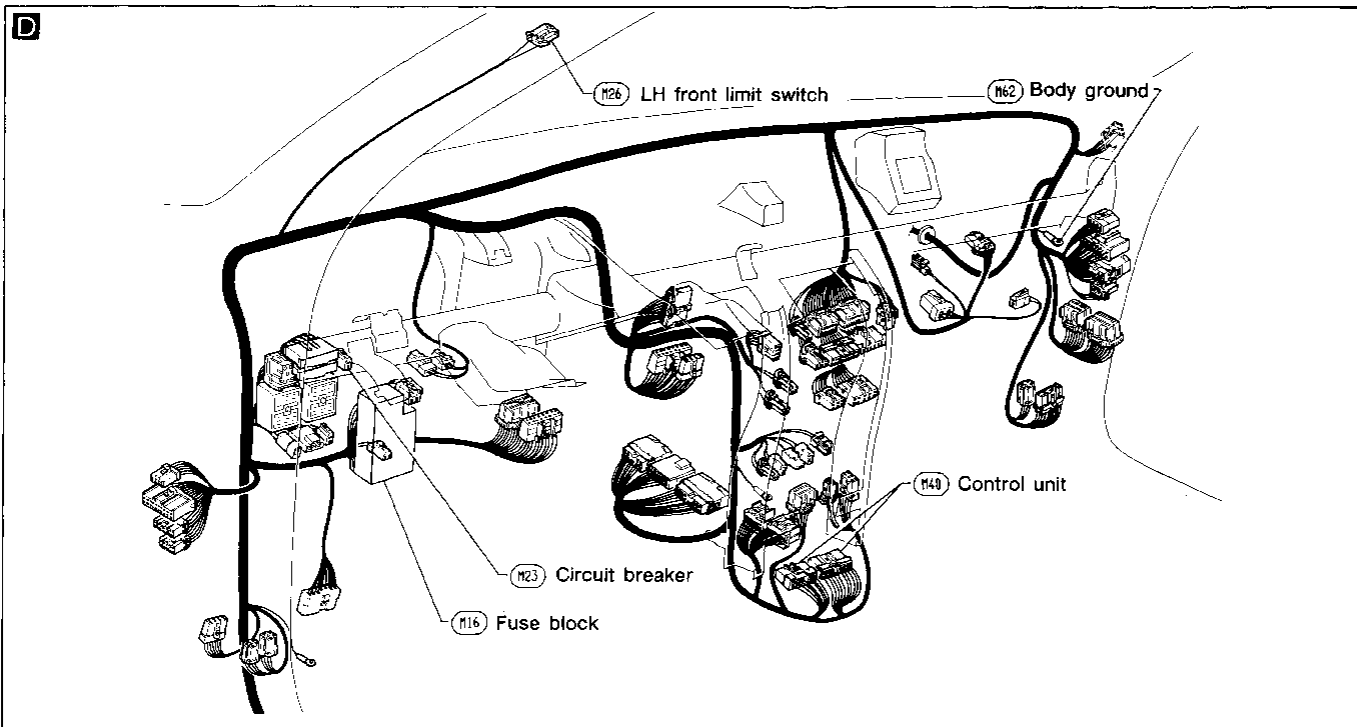

Circuit Diagram for Quick Pinpoint Check

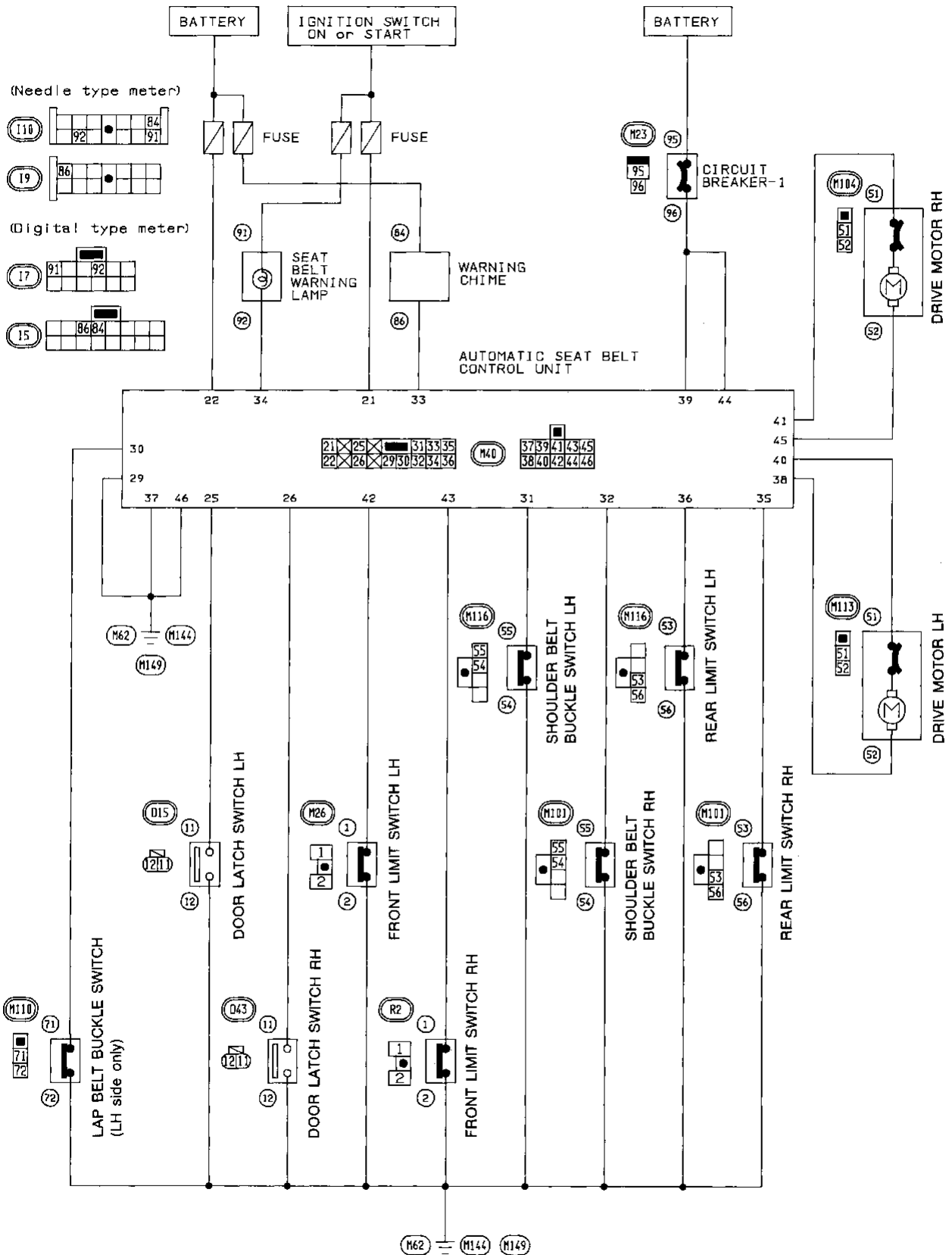

GI
MA
EM
LC
EF & EC
FE
CL
MT
AT
FA
RA
BR
ST
BF
HA
EL
IDX

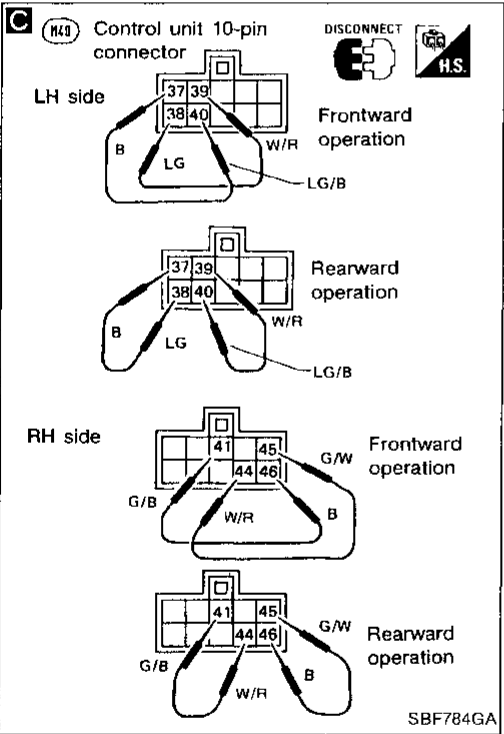
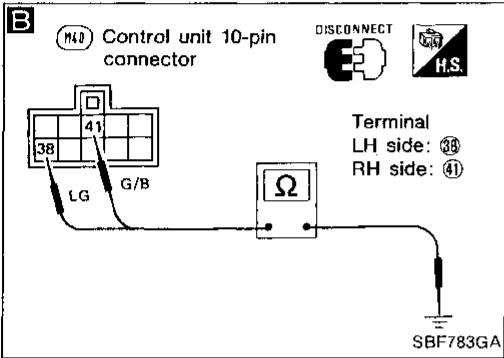
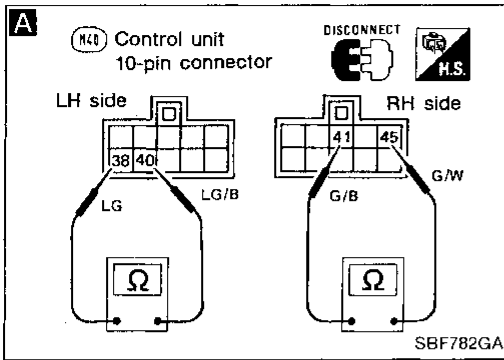

Diagnostic Procedure 1

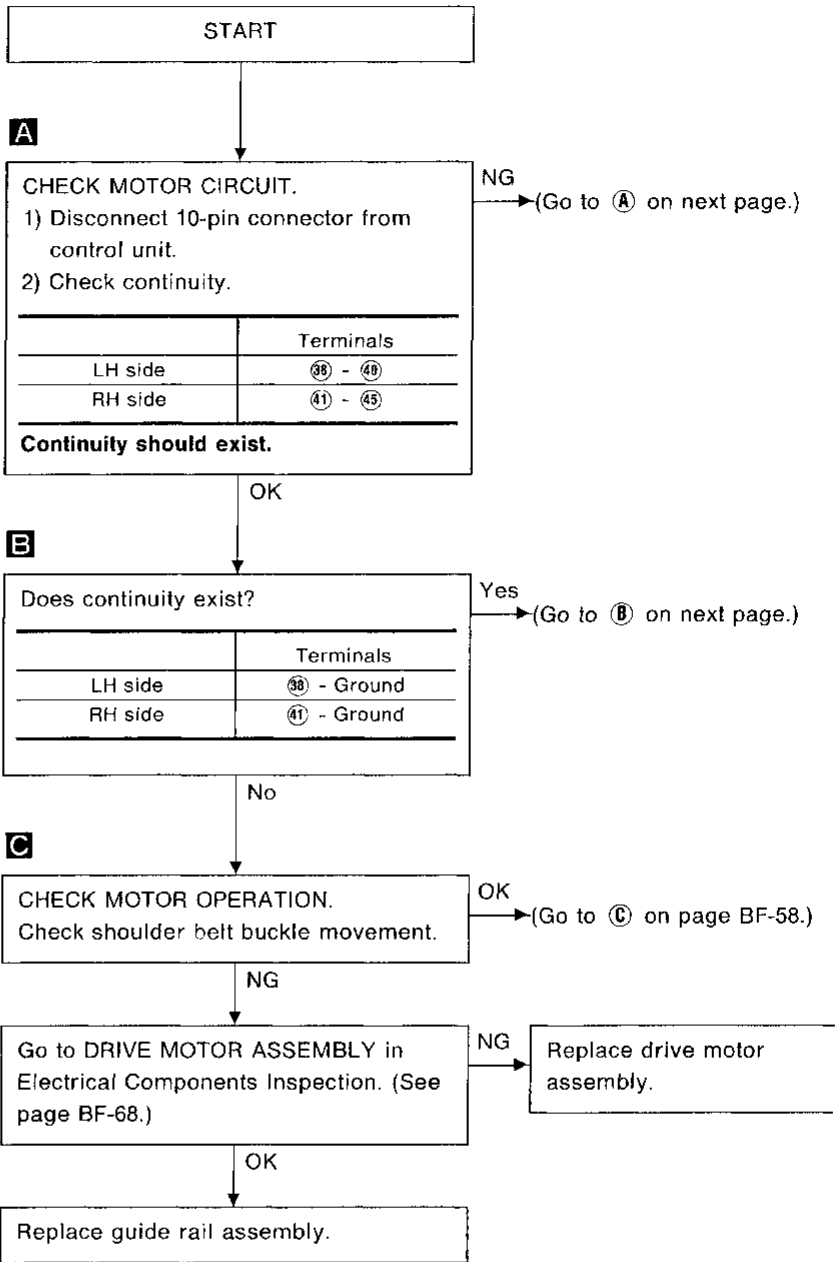

AUTOMATIC SEAT BELT SYSTEM — Trouble Diagnoses

Diagnostic Procedure 1 (Cont'd)

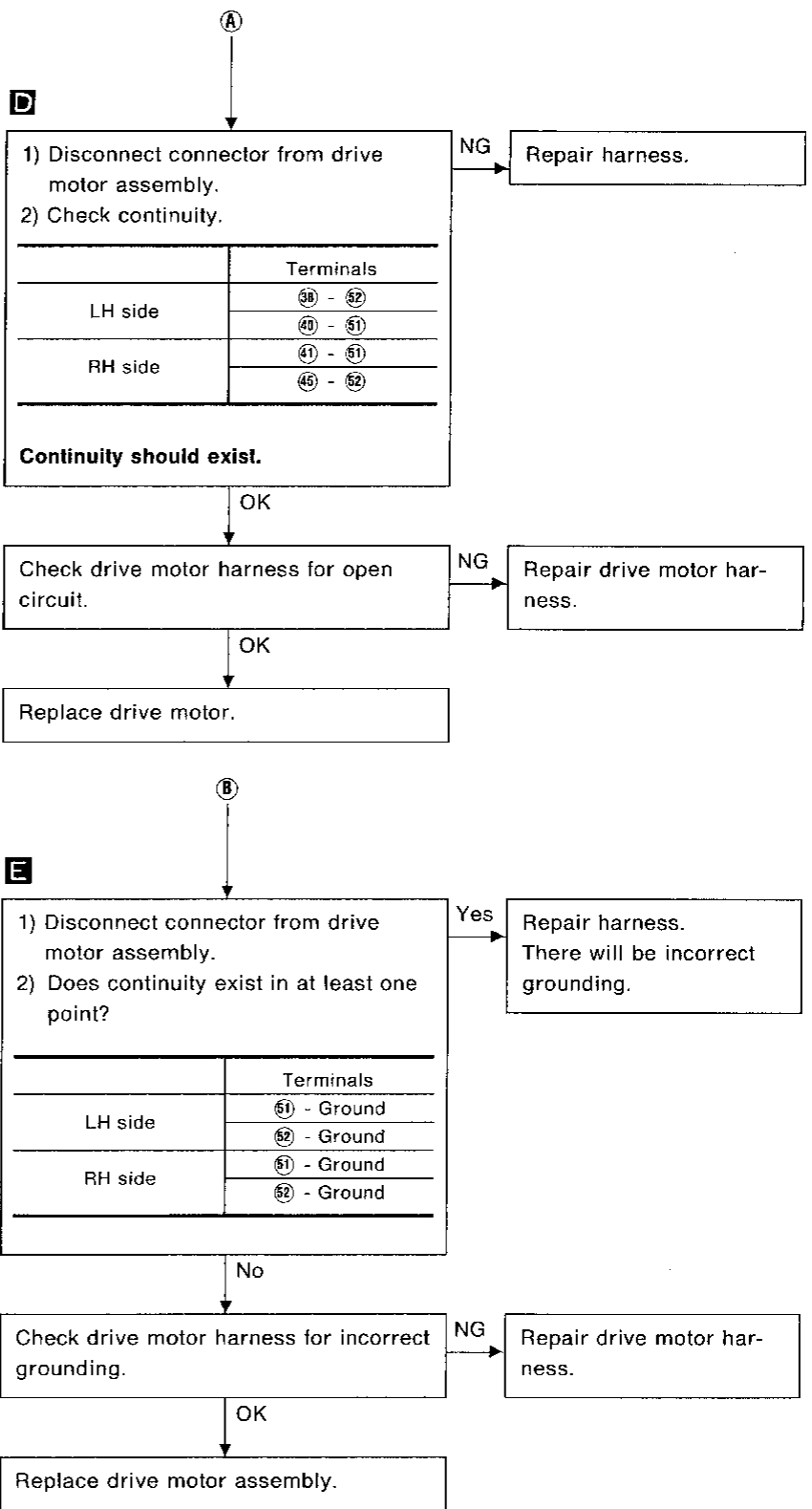
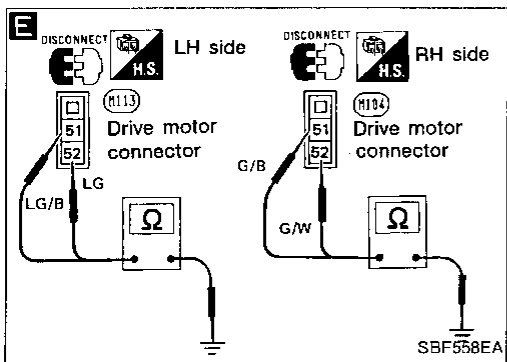
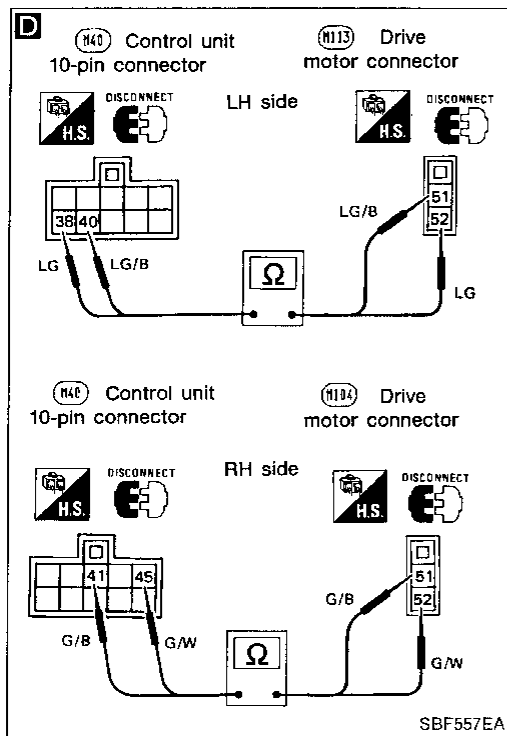

GI
MA
EM
LC
EF & EC
FE
CL
MT
AT
FA
RA
BR
ST
BF
HA
EL
IDX

AUTOMATIC SEAT BELT SYSTEM — Trouble Diagnoses

Diagnostic Procedure 1 (Cont'd)

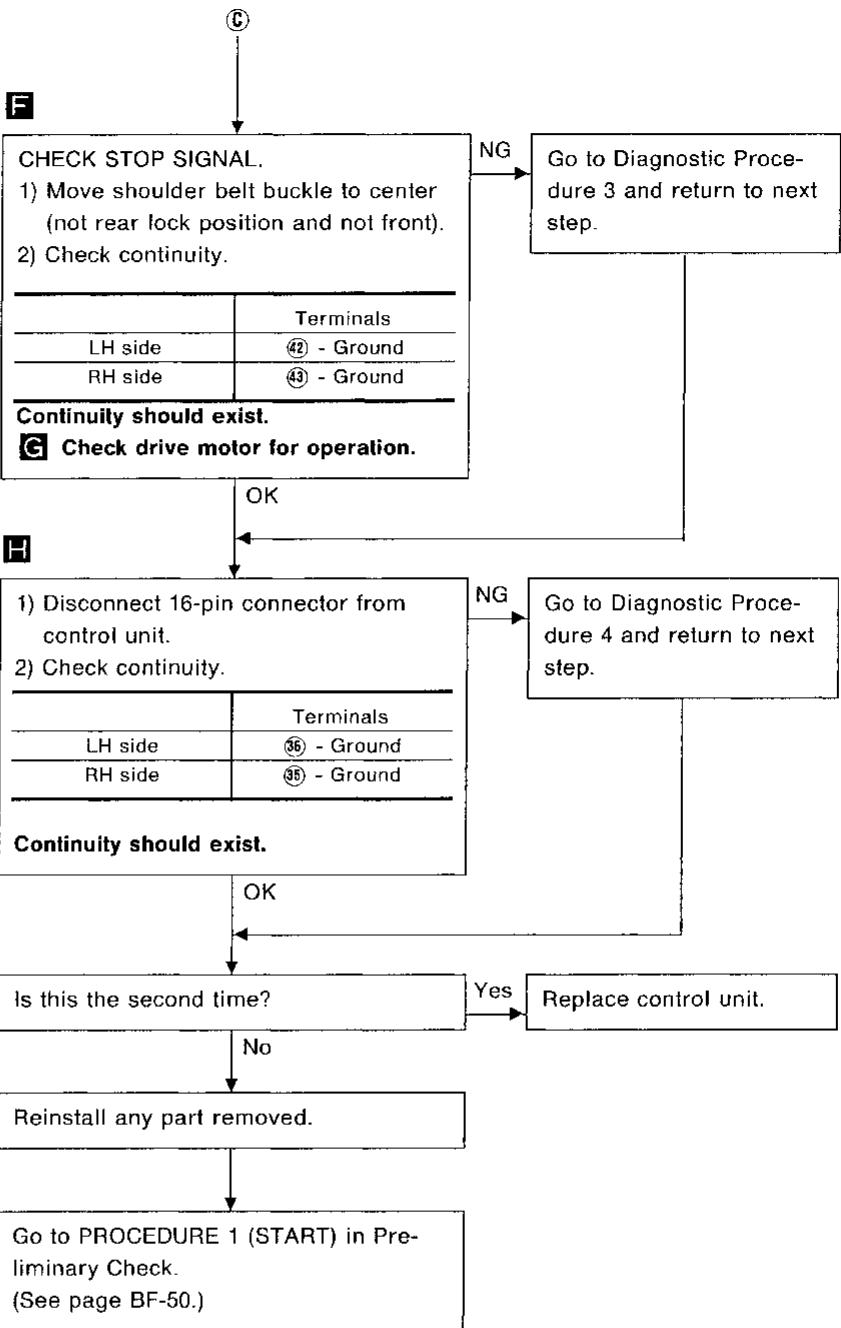
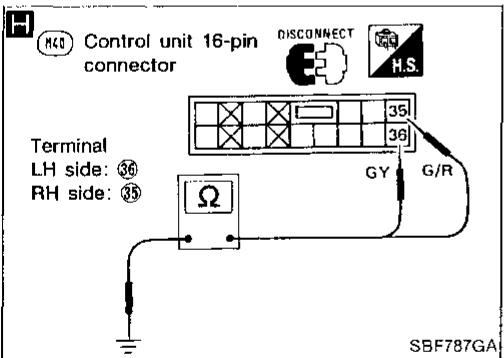
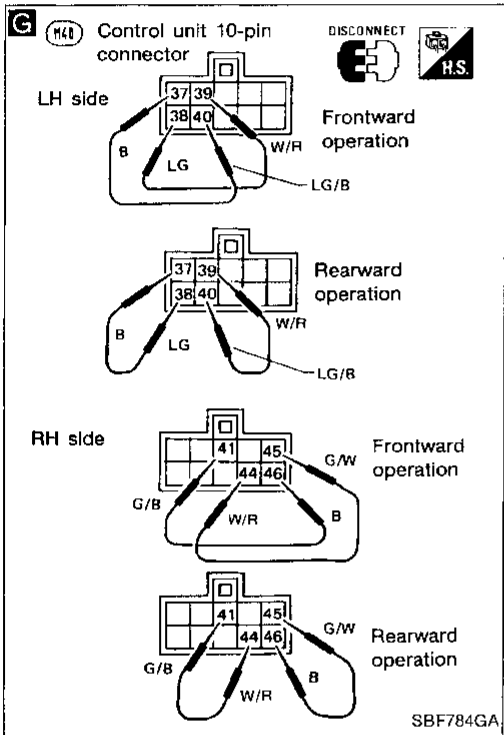
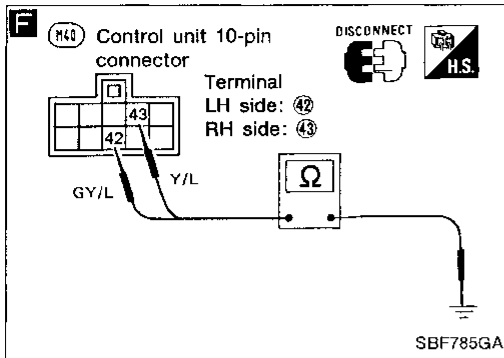

AUTOMATIC SEAT BELT SYSTEM — Trouble Diagnoses

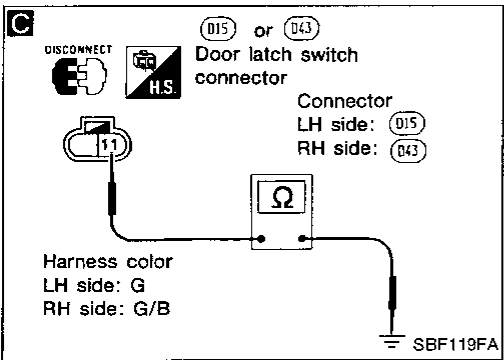
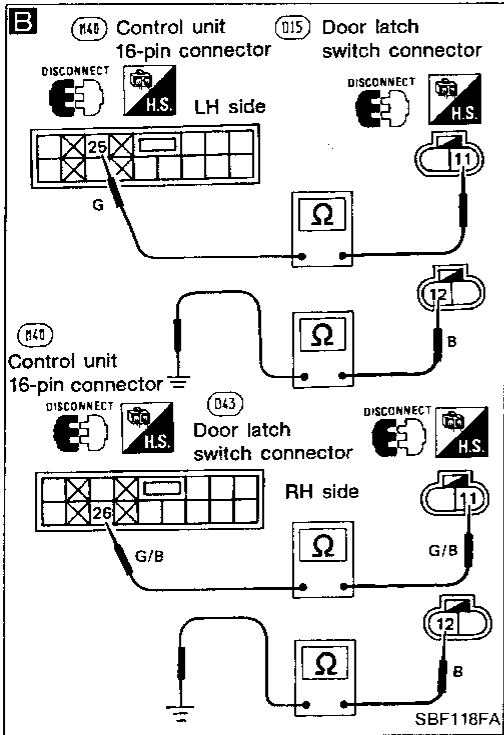
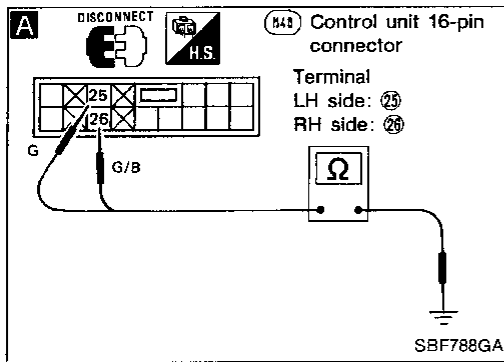

Diagnostic Procedure 2

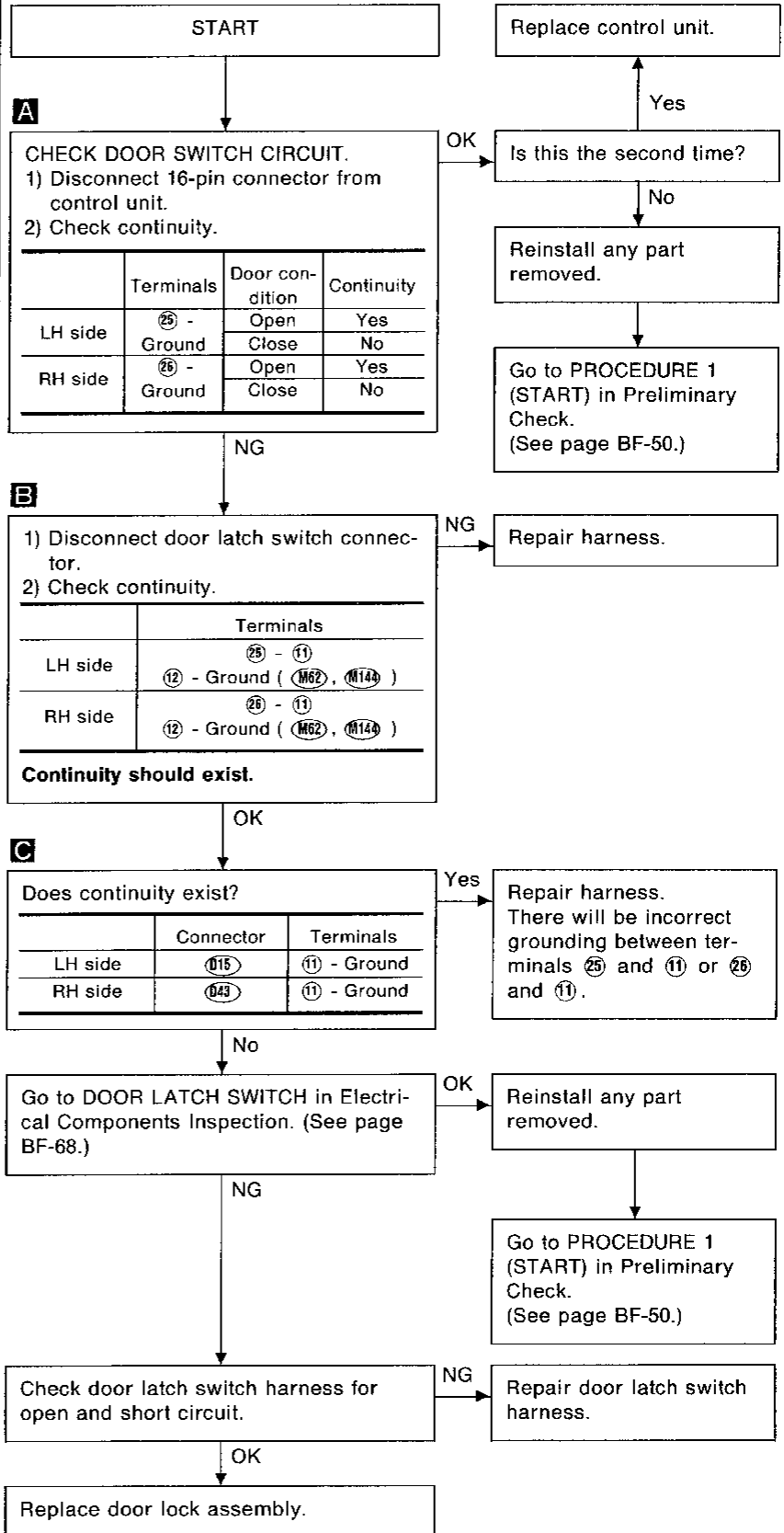

AUTOMATIC SEAT BELT SYSTEM — Trouble Diagnoses

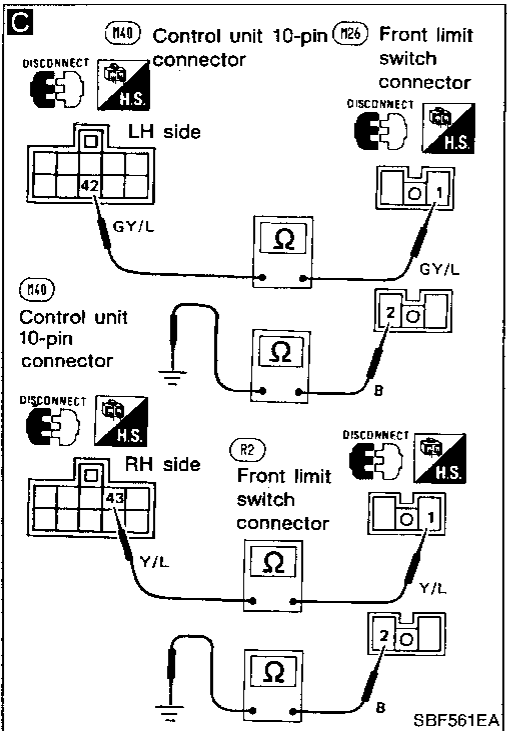
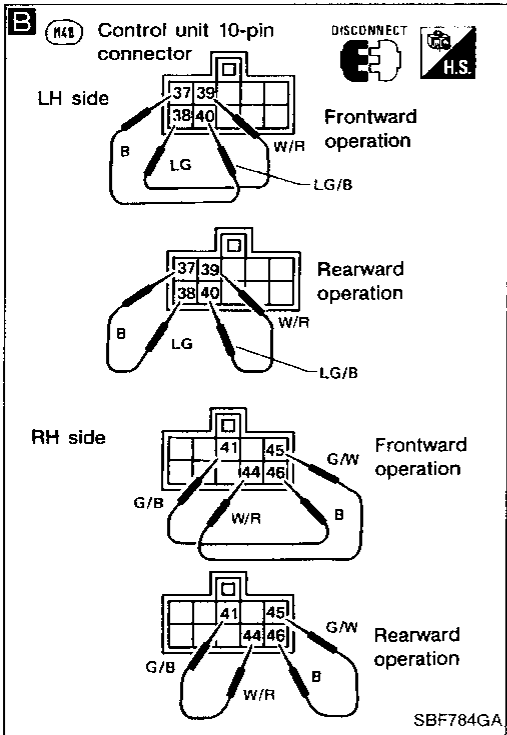
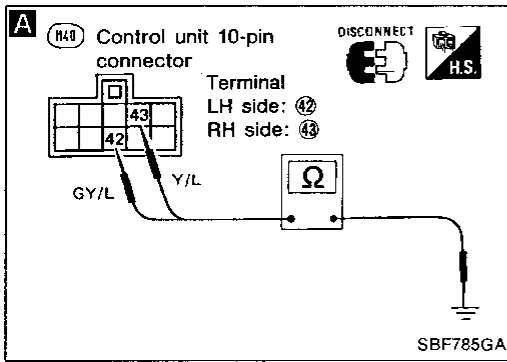

Diagnostic Procedure 3

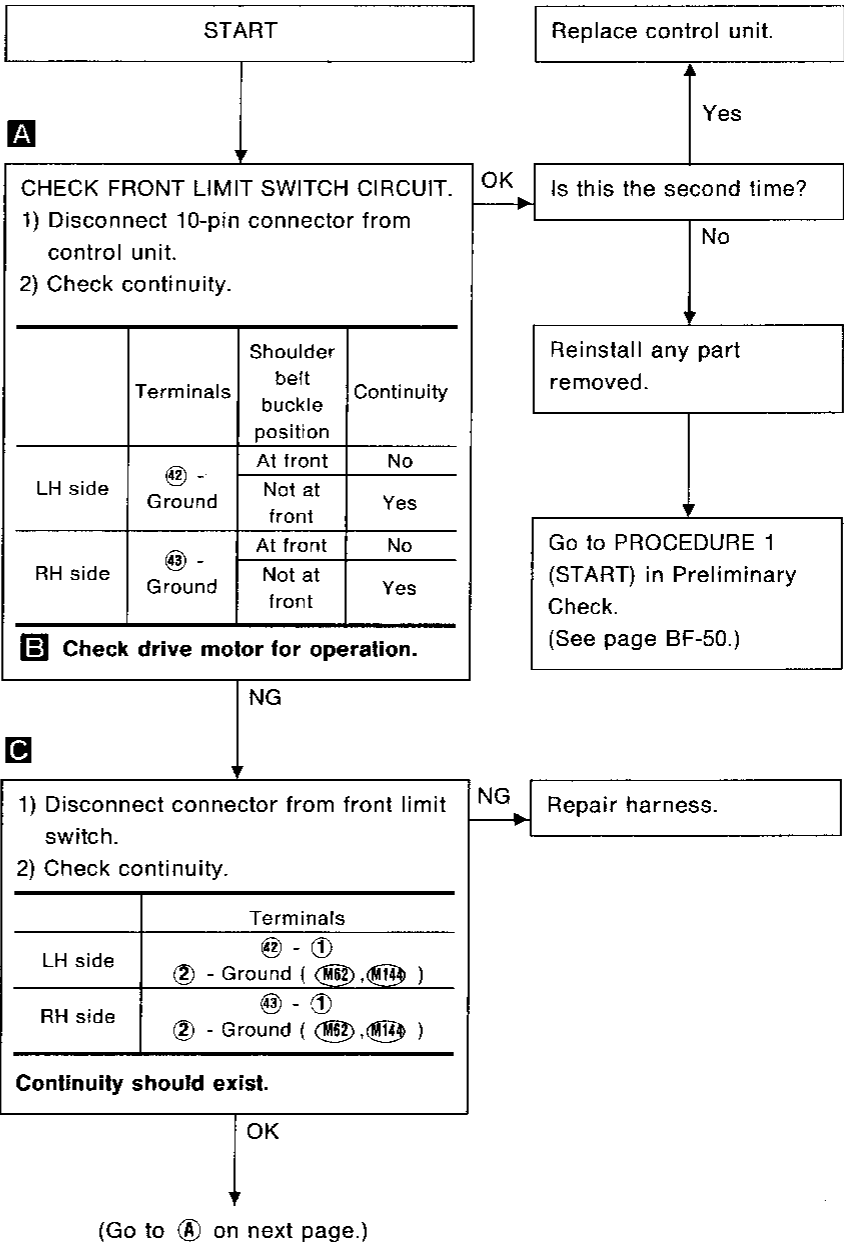

AUTOMATIC SEAT BELT SYSTEM — Trouble Diagnoses

Diagnostic Procedure 3 (Cont'd)

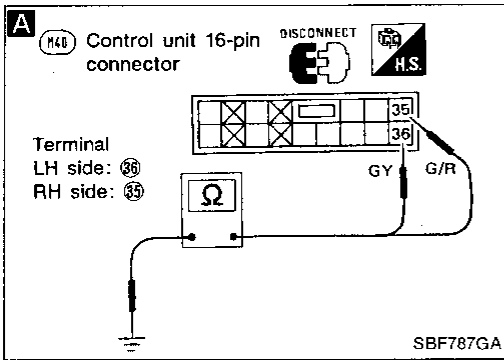
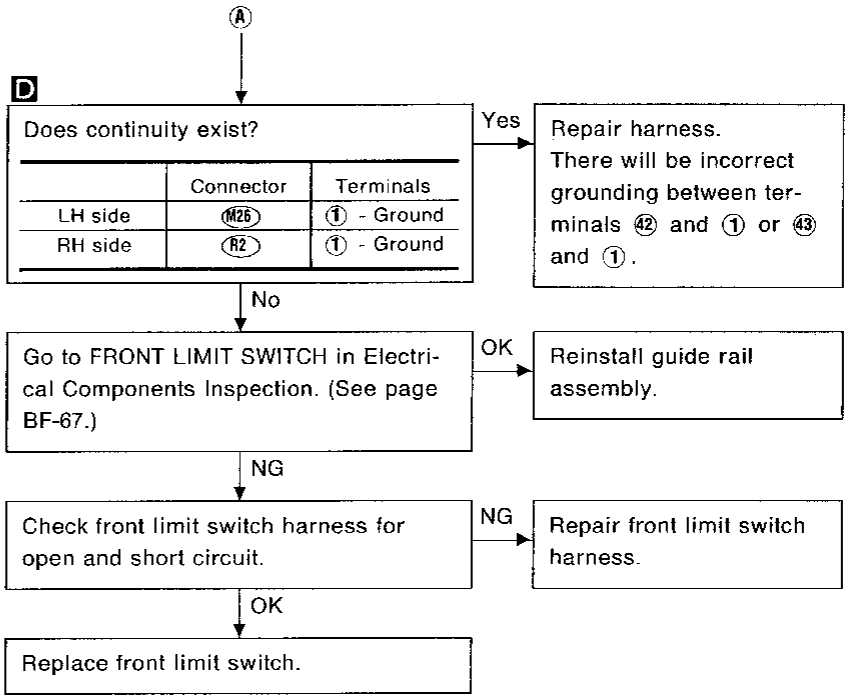
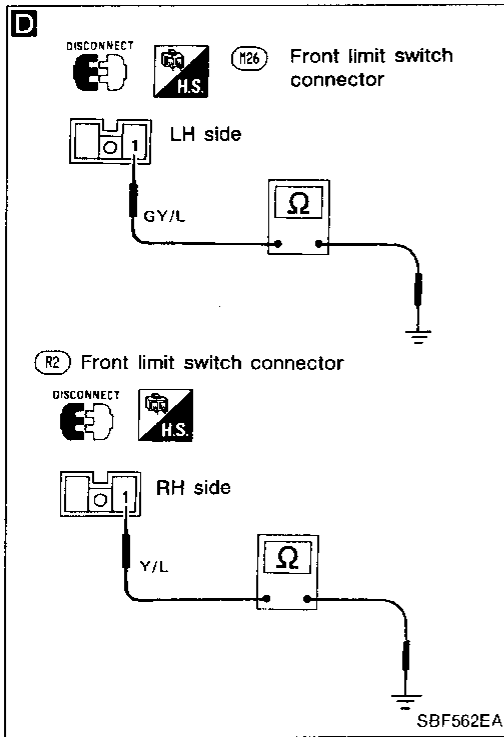

Diagnostic Procedure 4

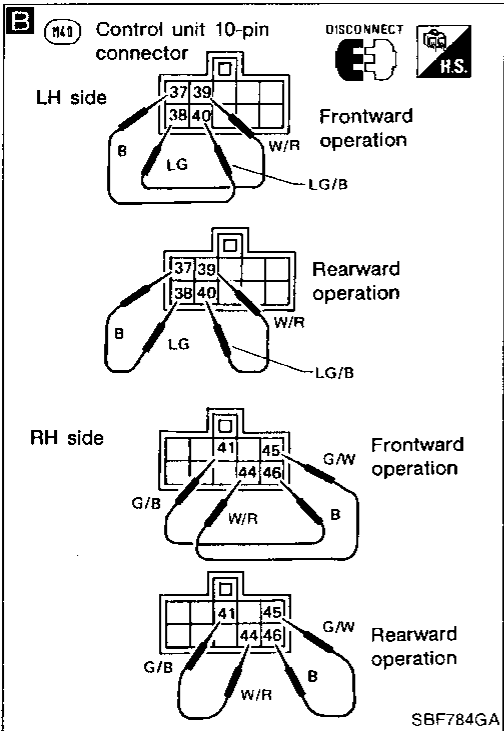
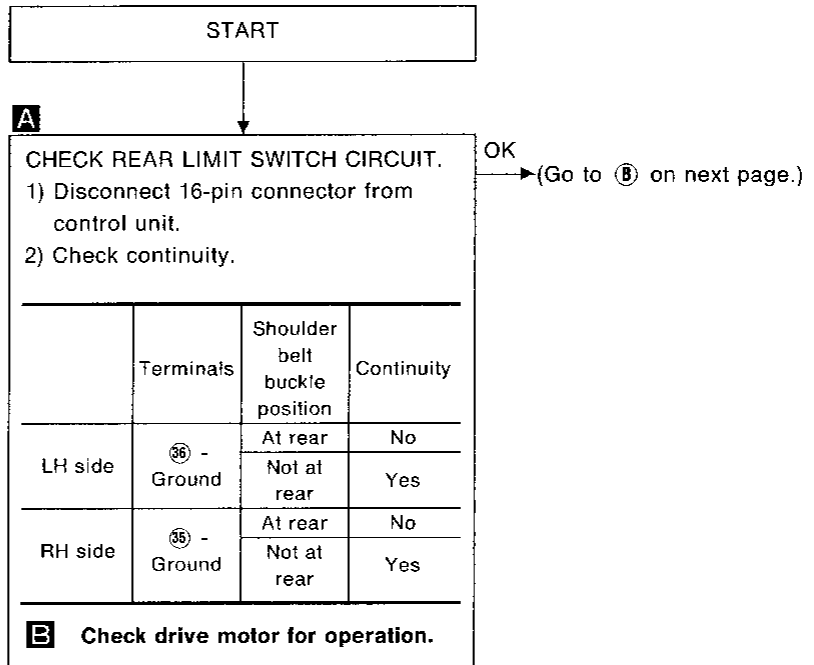

AUTOMATIC SEAT BELT SYSTEM — Trouble Diagnoses

Diagnostic Procedure 4 (Cont'd)

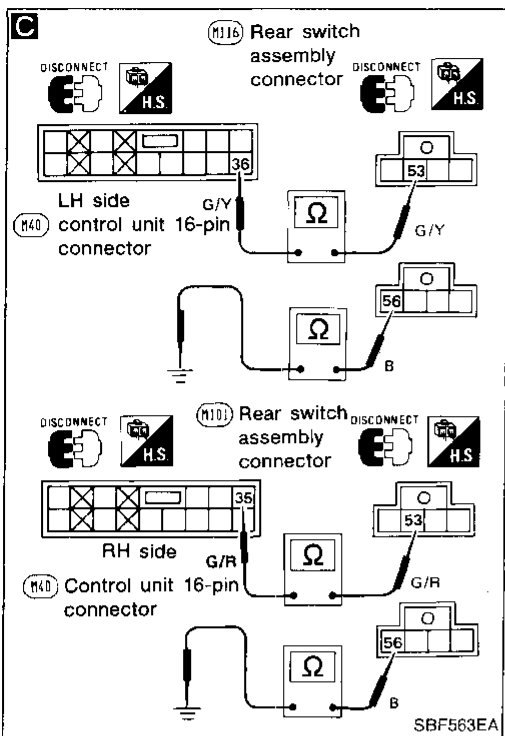

C

1) Disconnect connector from rear switch assembly.

2) Check continuity.

Terminals	
LH side	36 - 53
	56 - Ground (M62, M144)
RH side	35 - 53
	56 - Ground (M62, M144)

Continuity should exist.

NG → Repair harness.

OK →

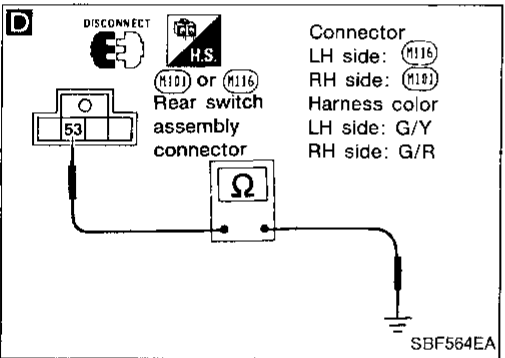

D

Does continuity exist?

	Connector	Terminals
LH side	(M116)	53 - Ground
RH side	(M101)	53 - Ground

Yes → Repair harness. There will be incorrect grounding between terminals 36 and 53 or 35 and 53.

No →

Go to REAR LIMIT SWITCH in Electrical Components Inspection. (See page BF-68.)

OK → (Go to B below.)

NG →

Check rear limit switch harness for open or short circuit.

NG → Repair rear limit switch harness.

OK →

Replace rear switch assembly.

B

Is this the second time?

Yes → Replace control unit.

No →

Reinstall any part removed.

Go to PROCEDURE 1 (STEP 3) (See page BF-50.) or PROCEDURE 2 (STEP 3) (See page BF-51.) in Preliminary Check.

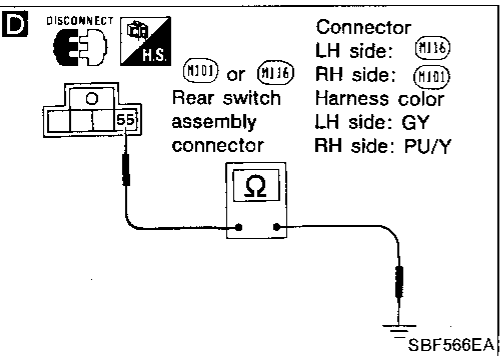
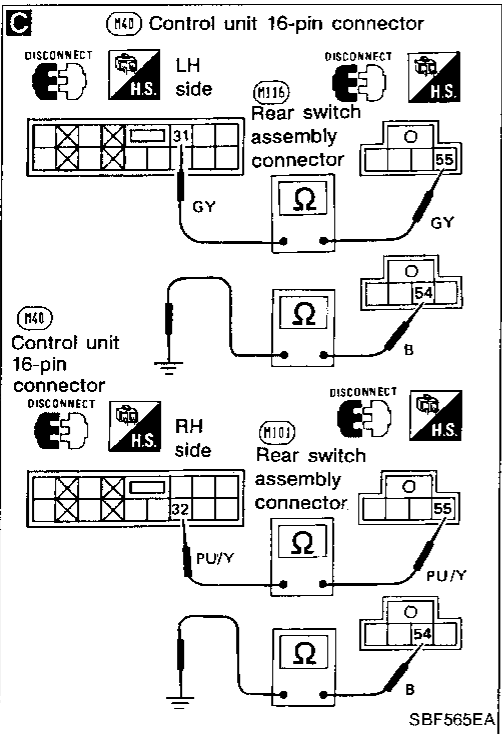
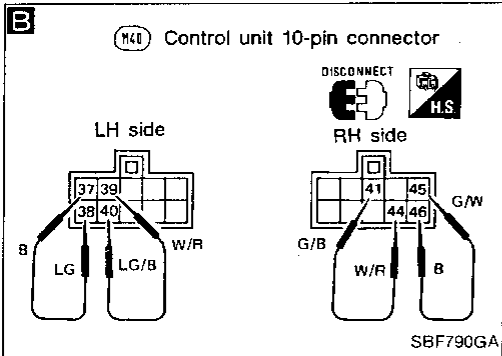
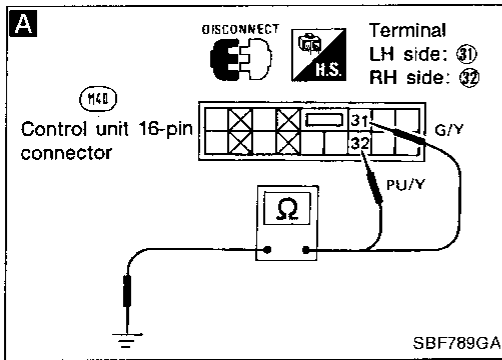

Diagnostic Procedure 5

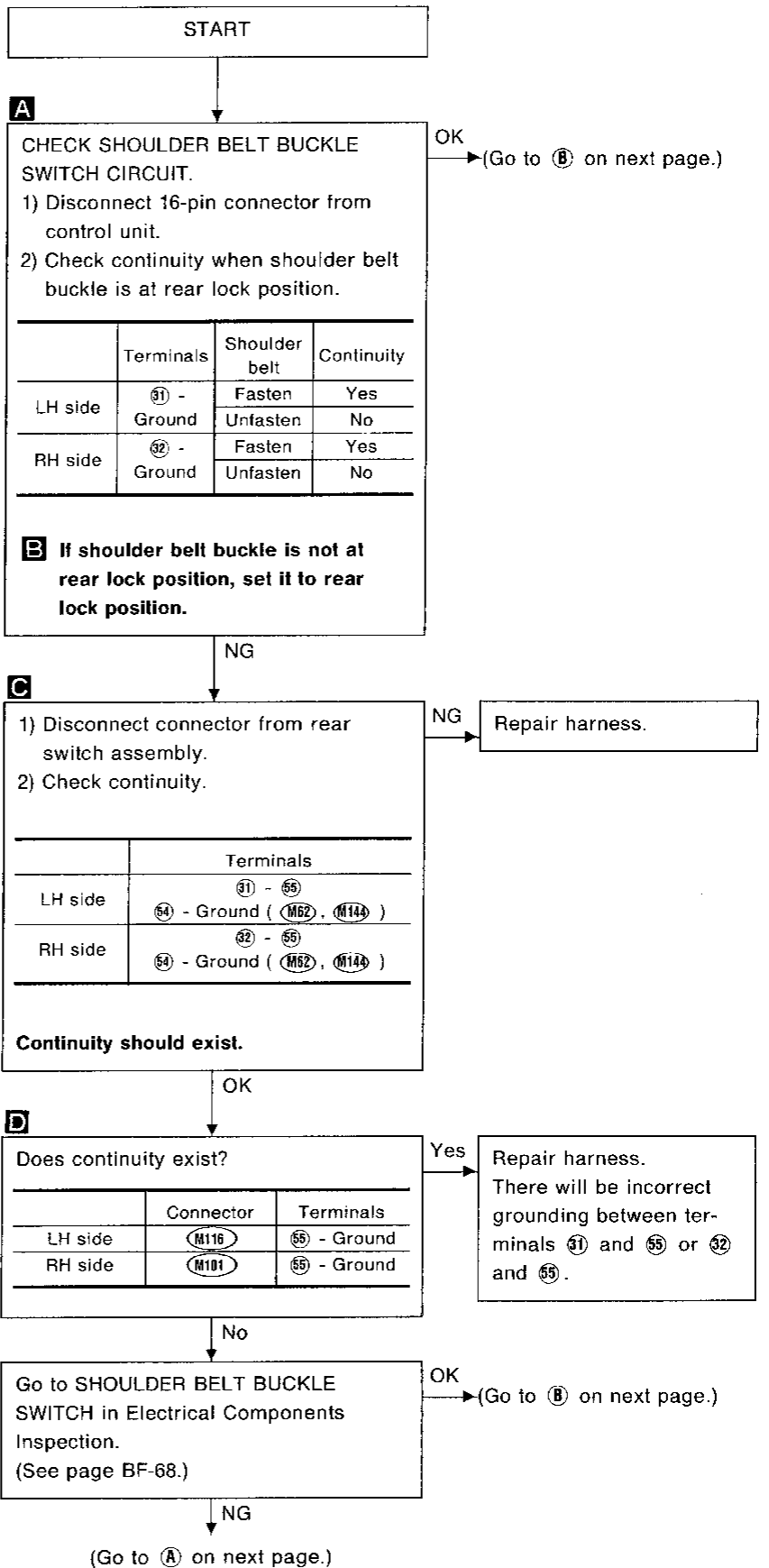

AUTOMATIC SEAT BELT SYSTEM — Trouble Diagnoses

Diagnostic Procedure 5 (Cont'd)

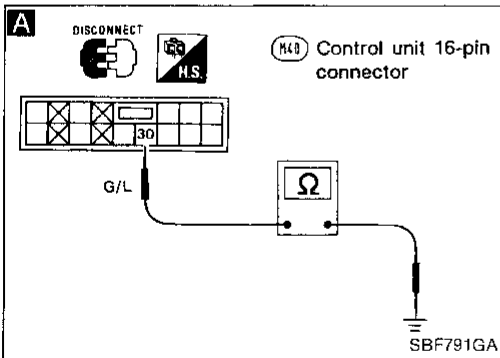
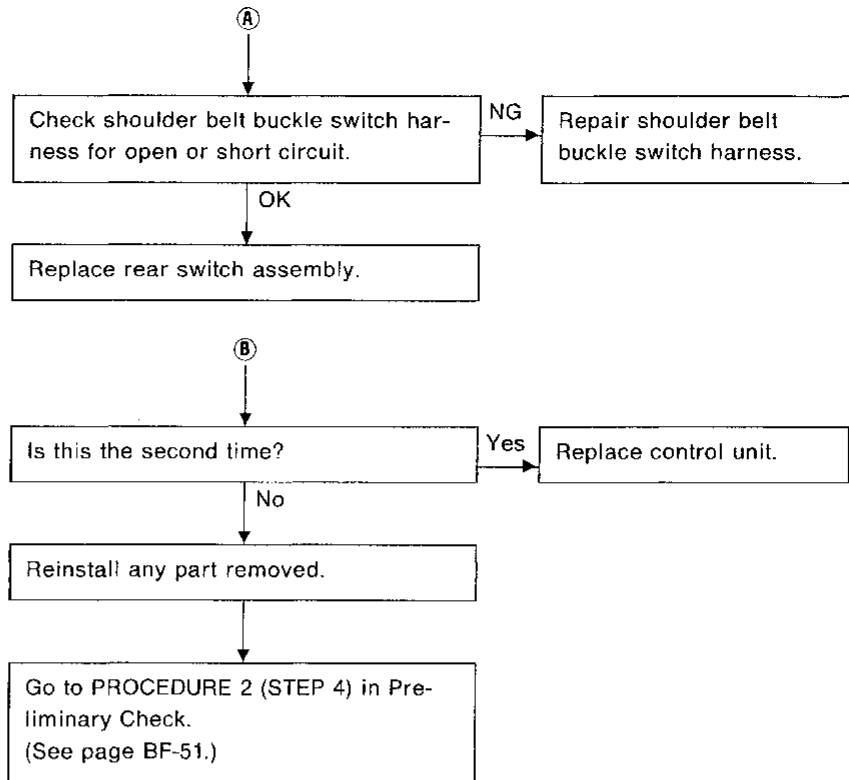

Diagnostic Procedure 6

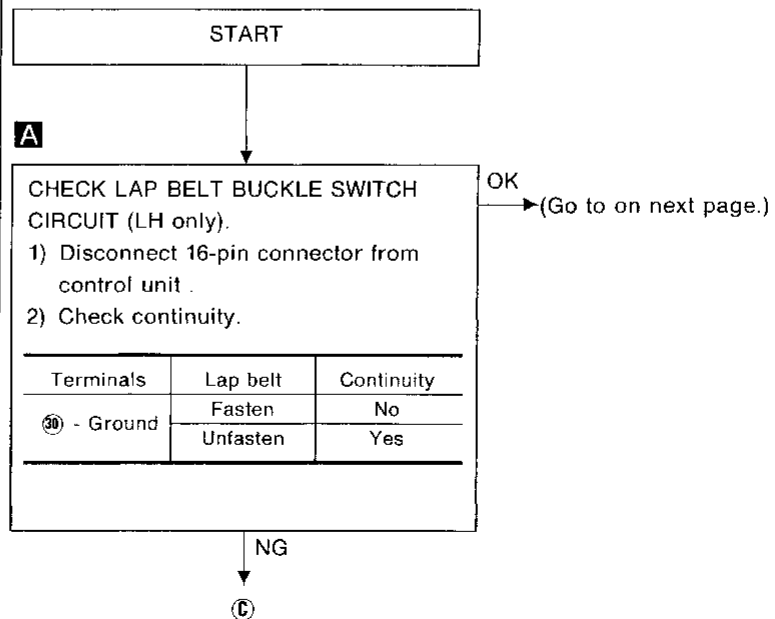

AUTOMATIC SEAT BELT SYSTEM — Trouble Diagnoses

Diagnostic Procedure 6 (Cont'd)

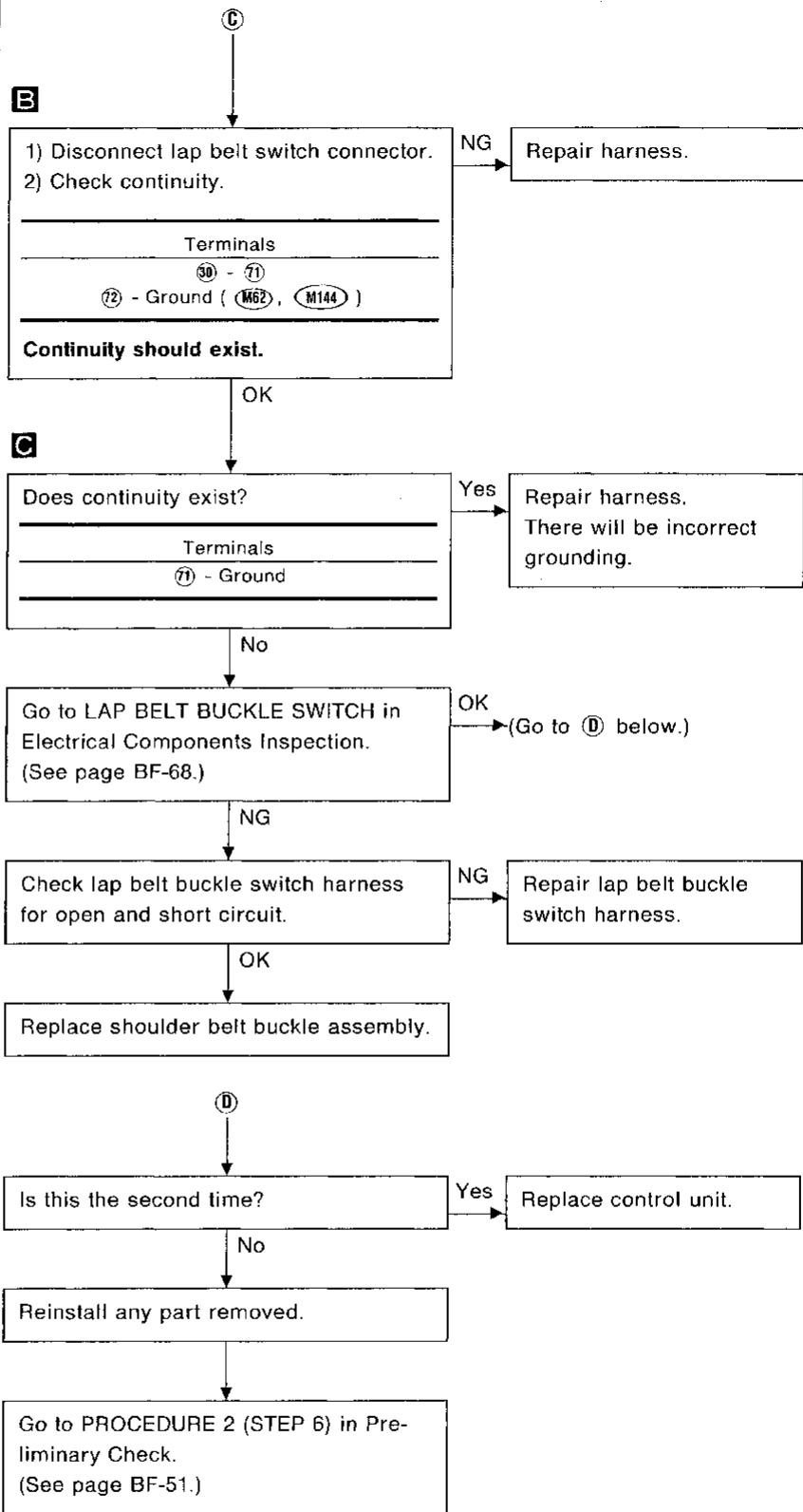
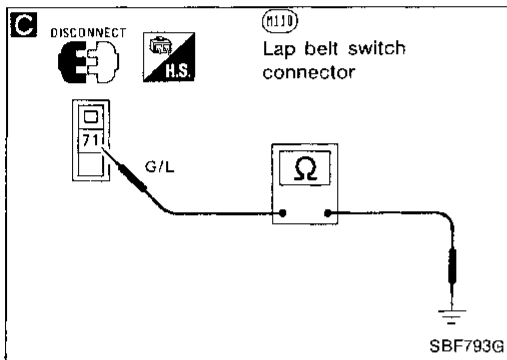
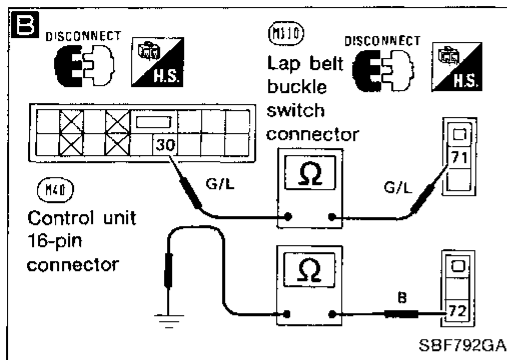

GI
MA
EM
LC
EF & EC
FE
CL
MT
AT
FA
RA
BR
ST
BF
HA
EL
IDX

AUTOMATIC SEAT BELT SYSTEM — Trouble Diagnoses

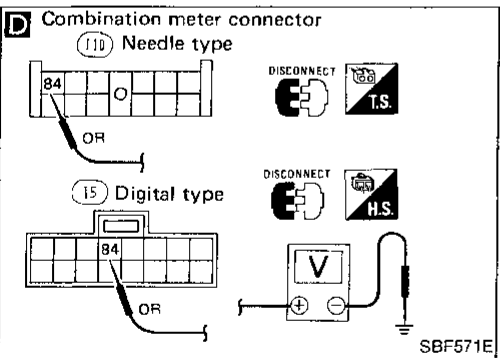
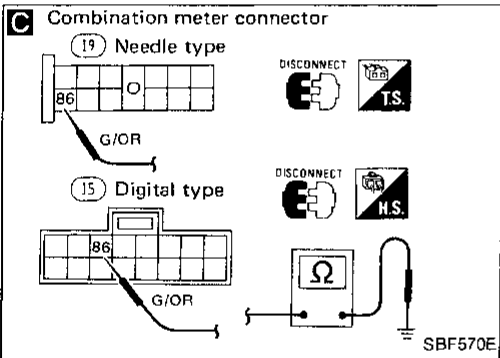
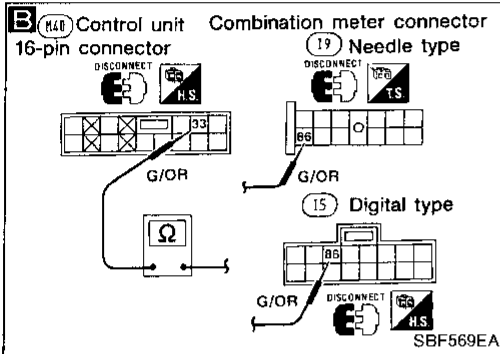
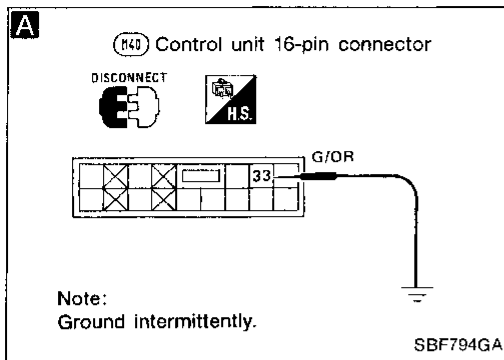

Diagnostic Procedure 7

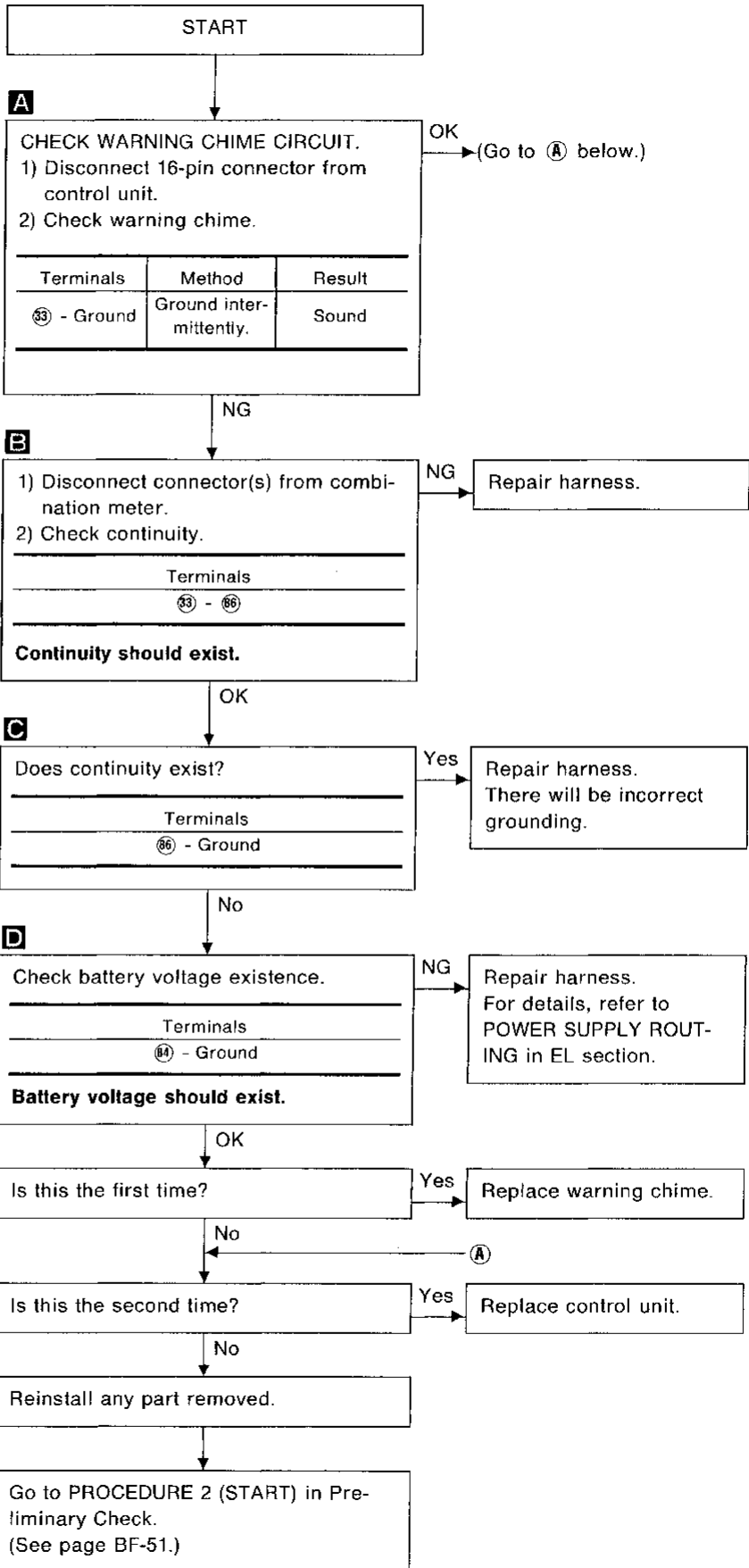

AUTOMATIC SEAT BELT SYSTEM — Trouble Diagnoses

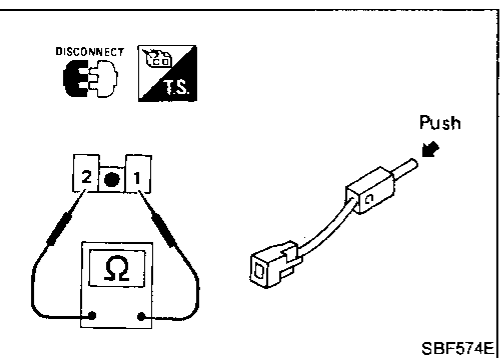
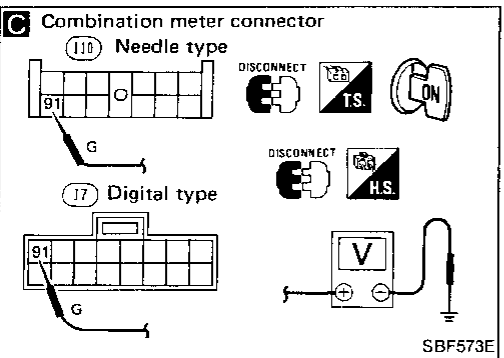
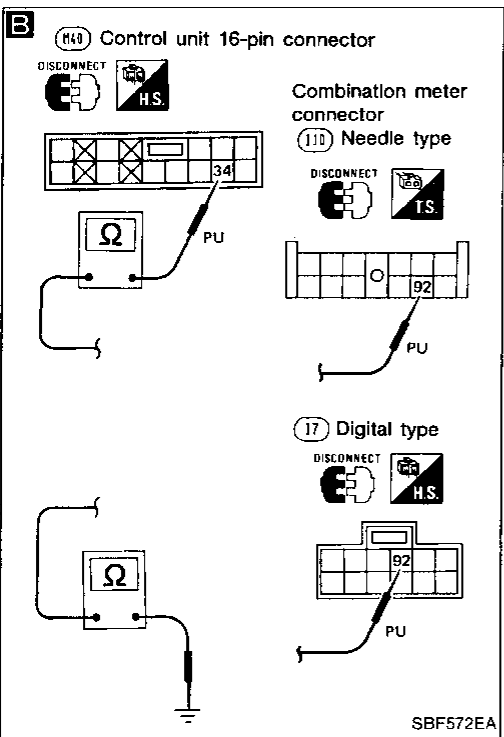
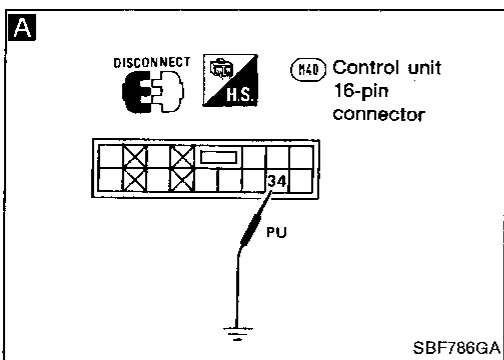

Diagnostic Procedure 8

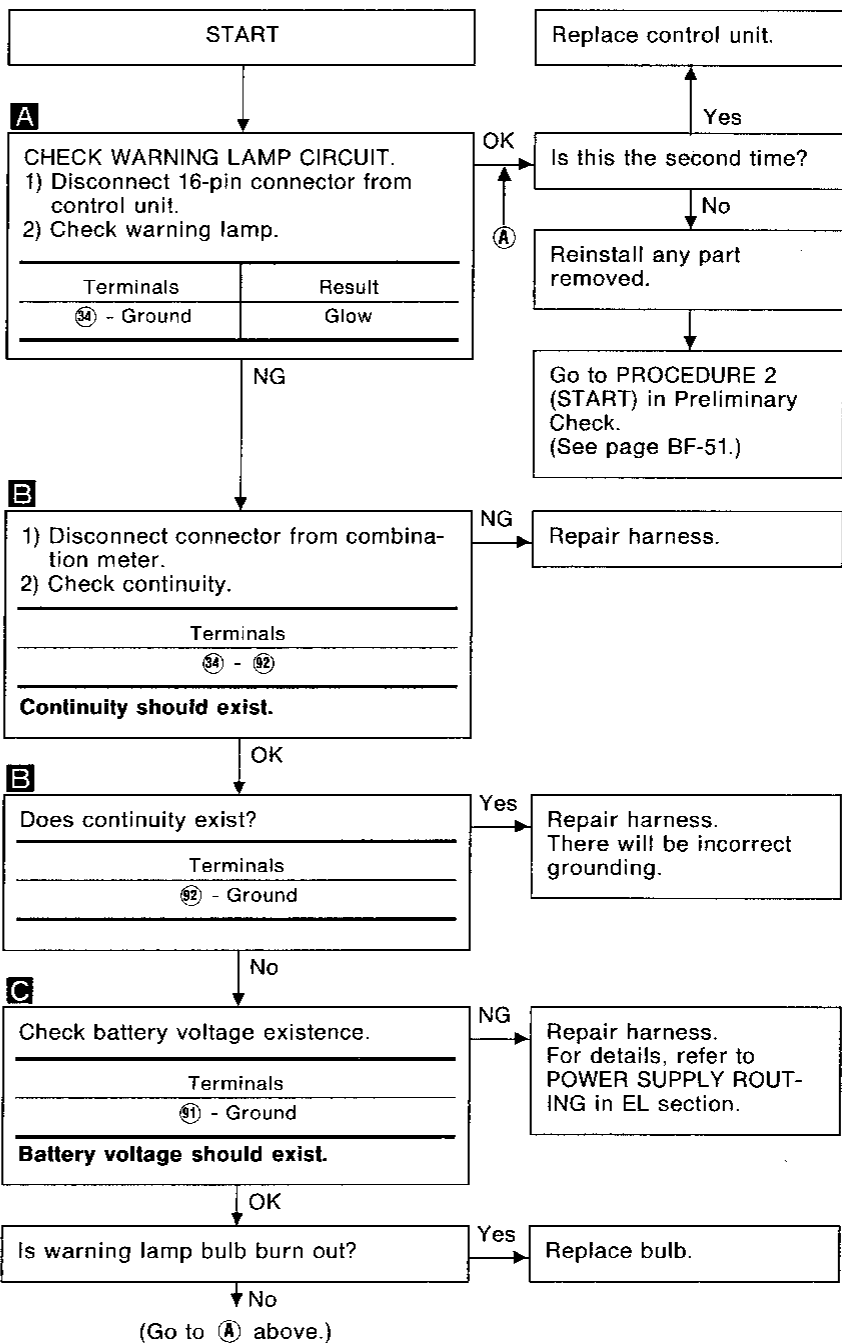

Electrical Components Inspection

FRONT LIMIT SWITCH

Condition	Continuity
Pushed	No
Released	Yes

AUTOMATIC SEAT BELT SYSTEM — Trouble Diagnoses

Electrical Components Inspection (Cont'd)

REAR LIMIT SWITCH

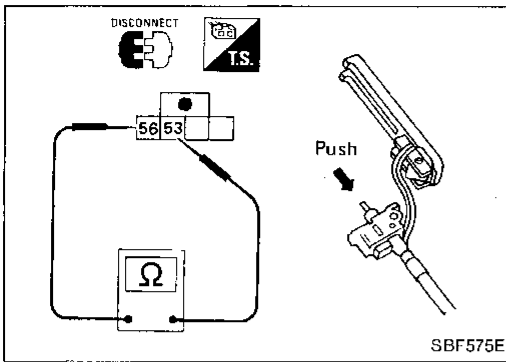

Condition	Continuity
Pushed	No
Released	Yes

SHOULDER BELT BUCKLE SWITCH

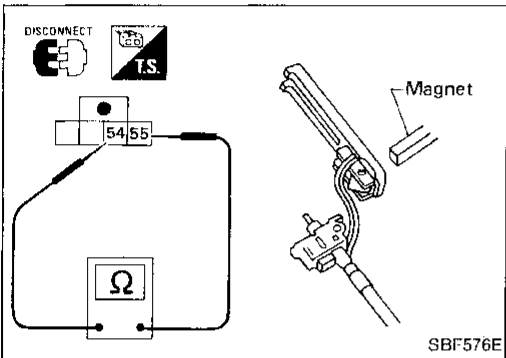

Condition	Continuity
Move magnet toward buckle switch.	Yes
Move magnet away buckle switch.	No

DOOR LATCH SWITCH (Built-in door lock assembly)

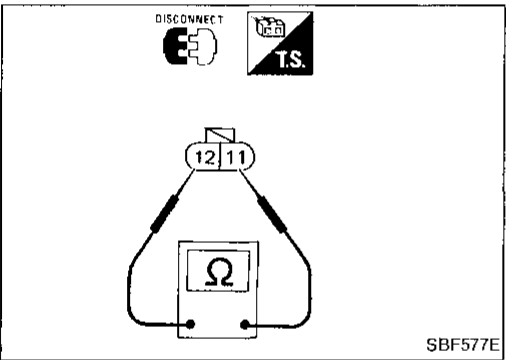

Door condition	Continuity
Open	Yes
Closed	No

DRIVE MOTOR ASSEMBLY

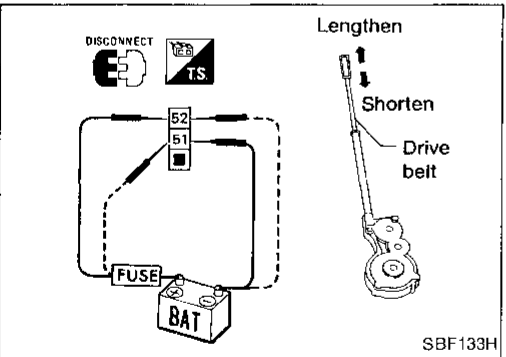

Terminals		Drive belt operation
⊕	⊖	
52	51	Lengthen
51	52	Shorten

LAP BELT BUCKLE SWITCH (Built-in lap belt buckle for LH side)

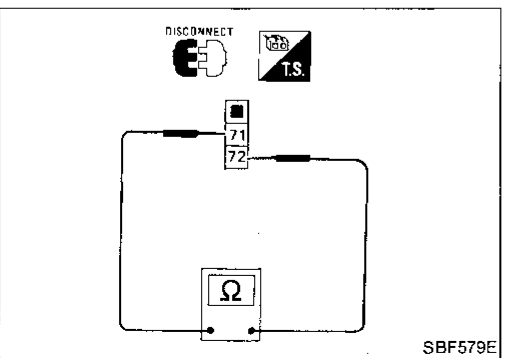

Condition	Continuity
Fastened	No
Unfastened	Yes

SUN ROOF

- After any adjustment, check sun roof operation and lid alignment.
- Handle finisher plate and glass lid with care so not to damage it.
- It is desirable for easy installation to mark each point before removal.

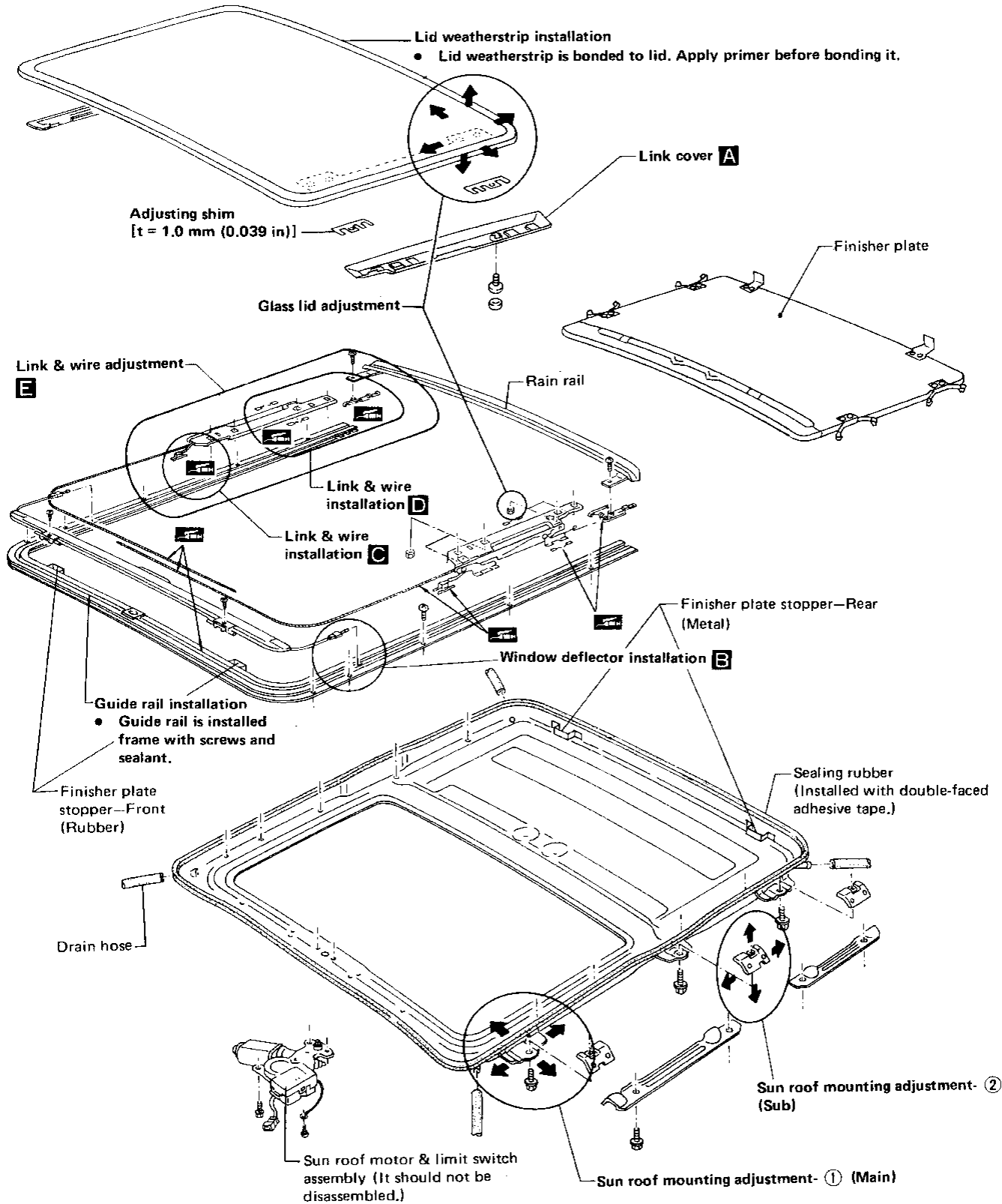

GI

MA

EM

LC

EF &
EC

FE

CL

MT

AT

FA

RA

BR

ST

BF

HA

EL

IDX

Link cover removal **A**

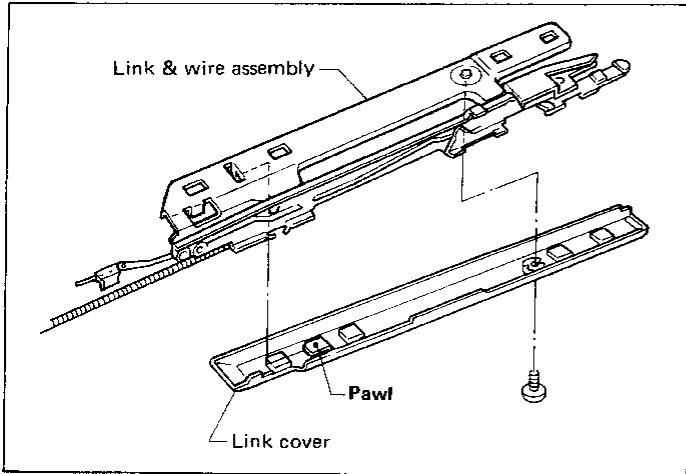

Link & wire installation (Front portion – For deflector control) **C**

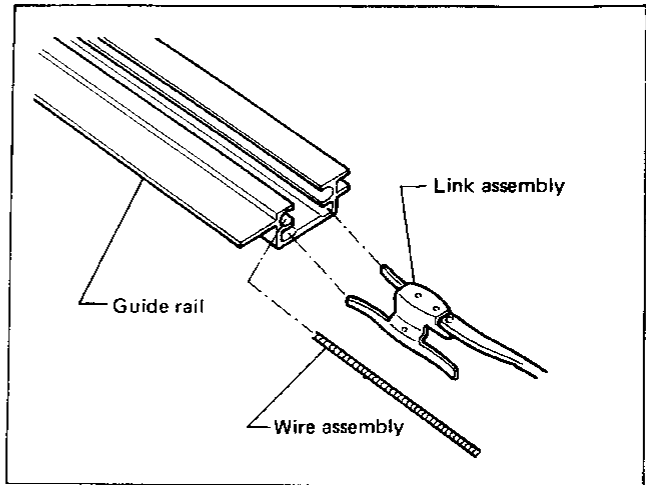

Wind deflector installation **B**

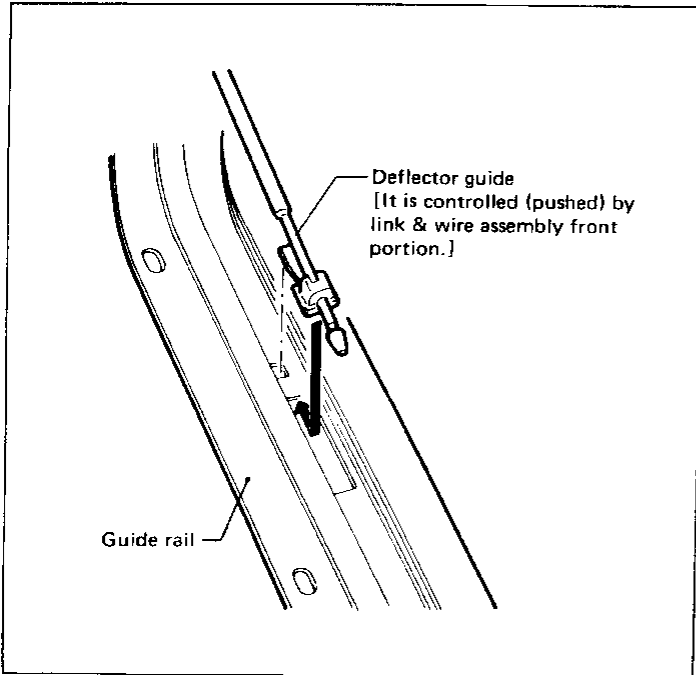

Link & wire installation (Rear portion) **D**

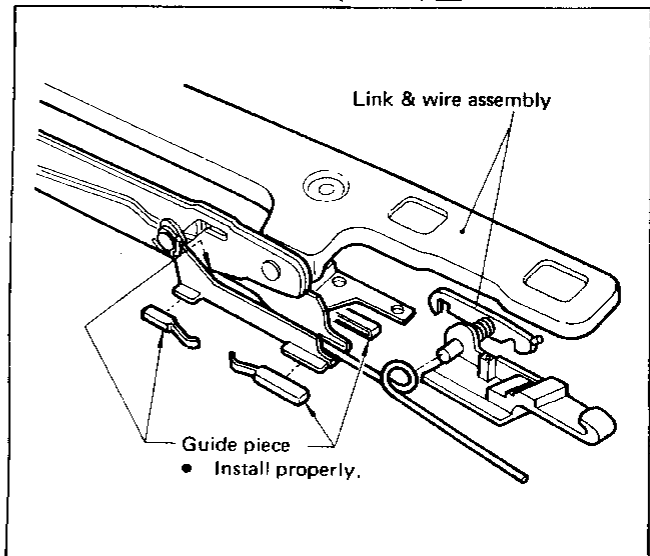

Link & wire adjustment **E**

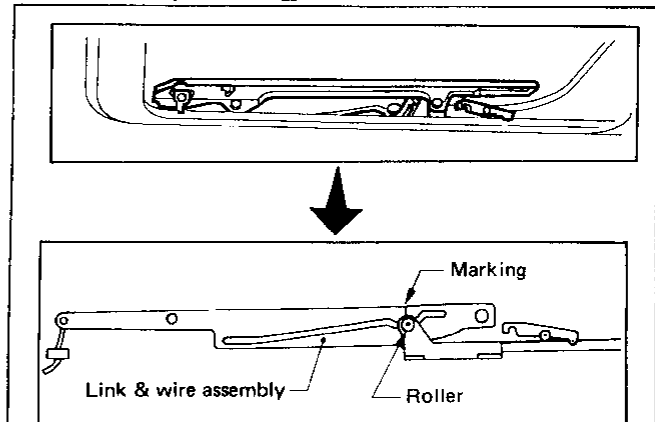

When installing motor & limit switch assembly, set motor & limit switch assembly to fully closed condition using the vehicle's harness and switch first. And adjust link & wire assembly's position as the roller line up at the marking. Then install the motor & limit switch assembly.

SBF466E

SUN ROOF

Wiring Diagram

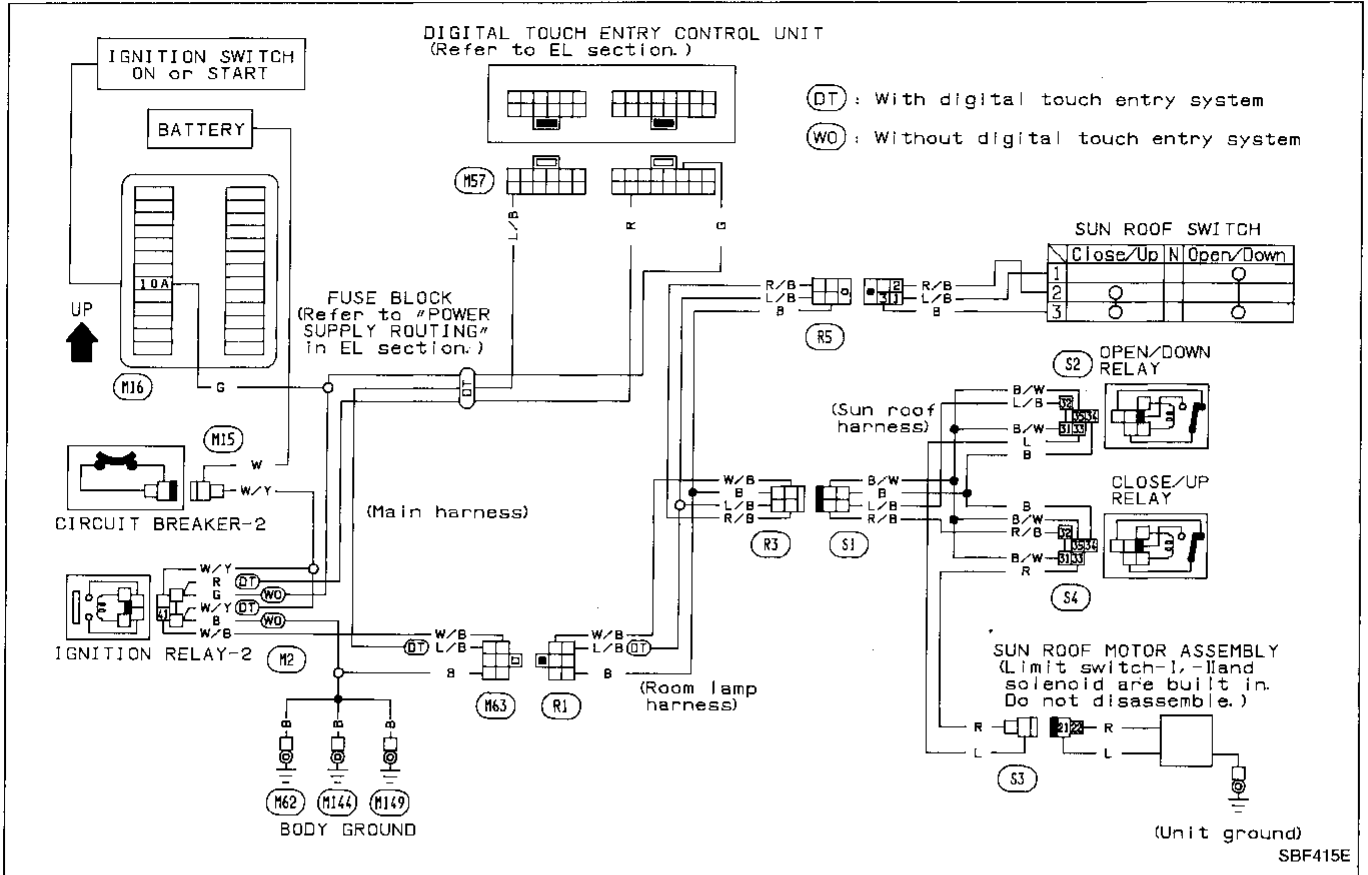

GI

MA

EM

LC

EF & EC

FE

CL

MT

AT

FA

RA

BR

ST

BF

HA

EL

IDX

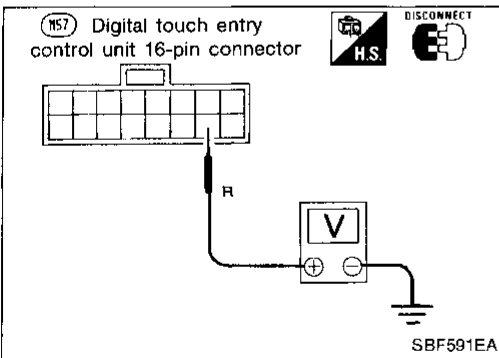

Power Supply Inspection (Equipped with digital touch entry system)

1.

Ignition switch	Voltage
OFF	12V
ON	12V

2.

Ignition switch	Voltage
OFF	0V
ON	12V

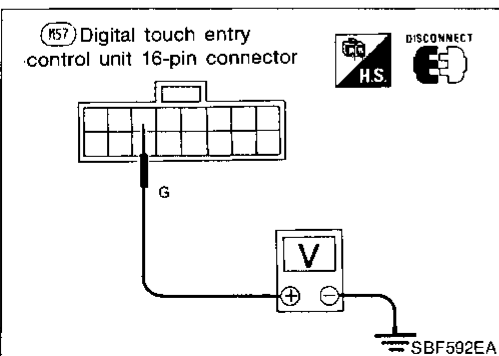

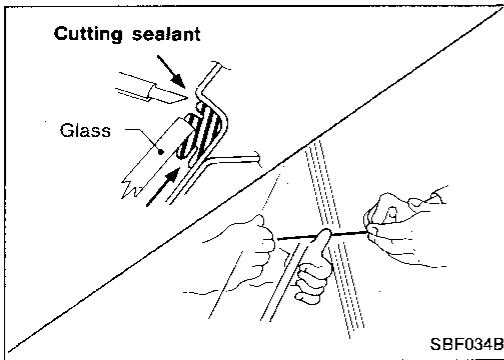

Windshield and Rear Window REMOVAL

After removing moldings, remove glass.

CAUTION:

Be careful not to scratch glass when removing.

INSTALLATION

- Use genuine Nissan Sealant kit or equivalent. Follow instructions furnished with it.
- After installation, the vehicle should remain stationary until the sealant hardens.

WARNING:

Keep heat and open flames away as primers are flammable.

CAUTION:

Advise the user of the fact that vehicle should not be driven on rough roads or surfaces until sealant has properly vulcanized.

- Do not use sealant which is past its usable term.
- Do not leave cartridge unattended with its cap open.
- Keep primers and sealant in a cool, dry place. Ideally, they should be stored in a refrigerator.
- Molding must be installed securely so that it is in position and leaves no gap.

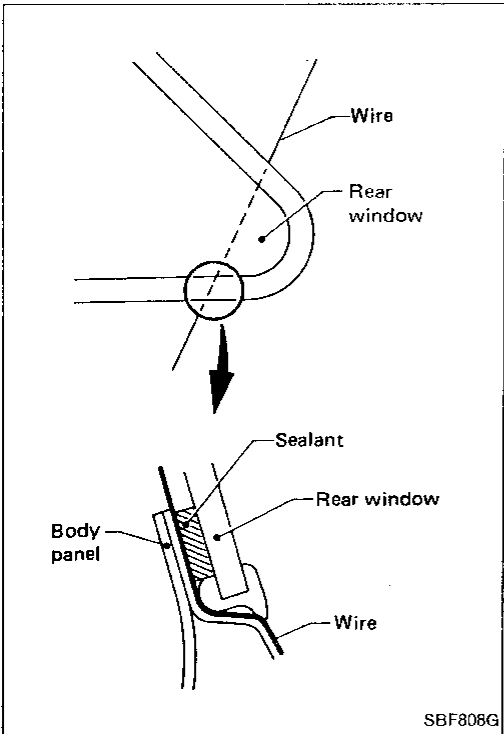

Molded type rear window

During removal, be careful not to scratch molding when cutting sealant. If molding is scratched, repair.

REPAIRING WATER LEAKS FOR WINDSHIELD

Leaks can be repaired without removing and reinstalling glass.

If water is leaking between caulking material and body or between glass and caulking material, determine the extent of the leak by applying water while pushing glass outward.

To stop the leak, apply primer (if necessary) and then sealant to the leak point.

WINDSHIELD AND WINDOWS

Windshield and Rear Window (Cont'd)

Body side

Install spacers to panel.

Windshield

530 (20.87)

Rear window

500 (19.69)

Unit: mm (in)

SBF470E

Install molding fastener.
When installing it, heat body panel and fastener to approx. 30 to 40° C (86 to 104° F)

SBF849C

Apply additional sealant uniformly to the lower portion of glass, as shown below:

More than 5 mm (0.20 in)

SBF720C

Glass side

Windshield

Install dam rubber.
When installing, be sure joint is centered and at lower portion of glass.

SBF996E

Gap (A) between dam rubber and upper glass edge:
8 mm (0.31 in)

Gap (A) between dam rubber and side glass edge:
8 mm (0.31 in)

Gap (A) between dam rubber and lower glass edge:
41 mm (1.61 in)

Rear window

Install dam rubber.
When installing, be sure joint is centered and at lower portion of glass.

SBF204D 12 mm (0.47 in)

Apply sealant evenly.
Windshield and rear window

7 - 8 (0.28 - 0.31)

12 - 15 (0.47 - 0.59)

Unit: mm (in)

MBF884A

GI

MA

EM

LC

EF &
EC

FE

CL

MT

AT

FA

RA

BR

ST

BF

HA

EL

IDX

MIRROR

Door Mirror

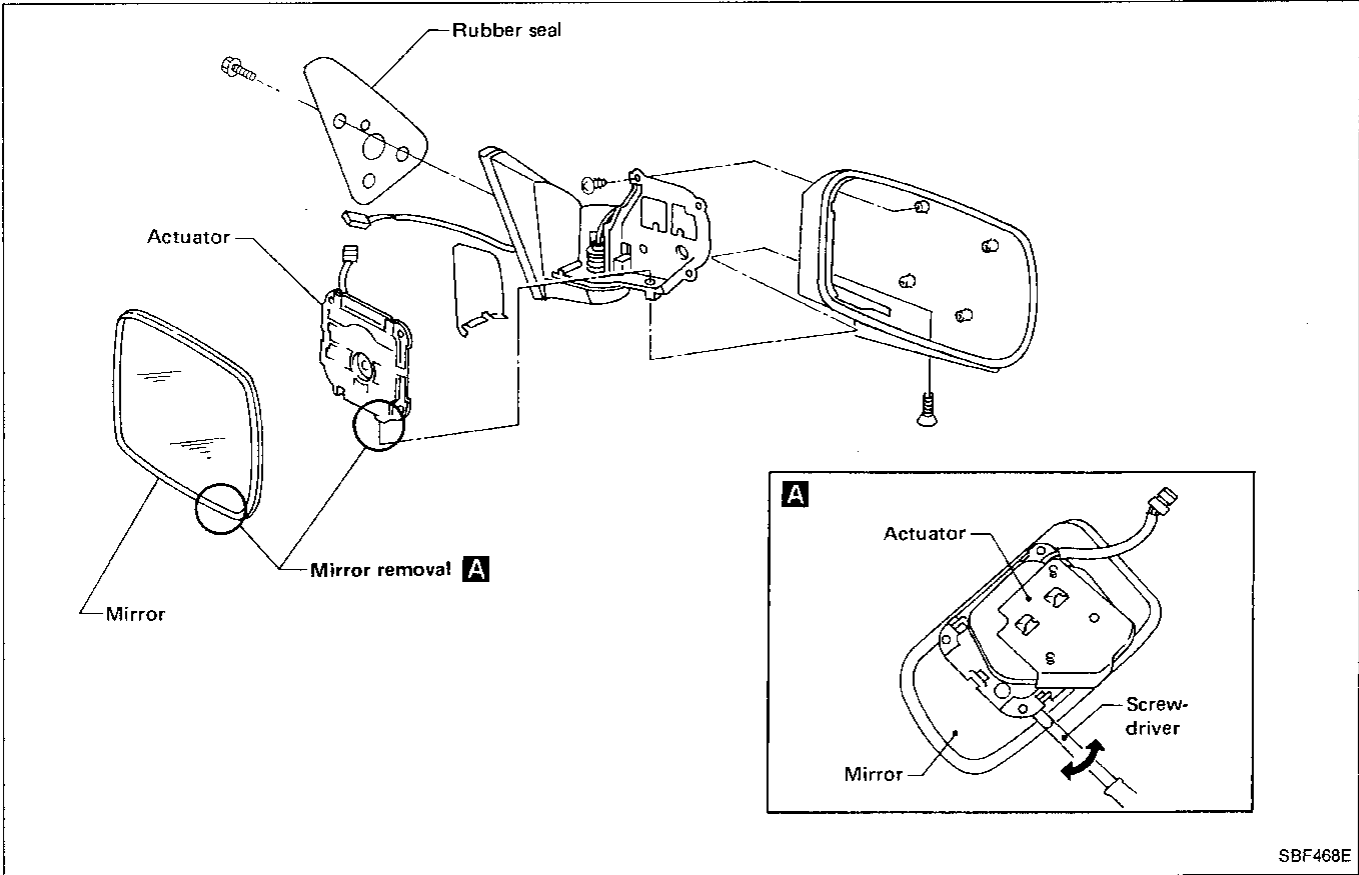

SBF468E

WIRING DIAGRAM

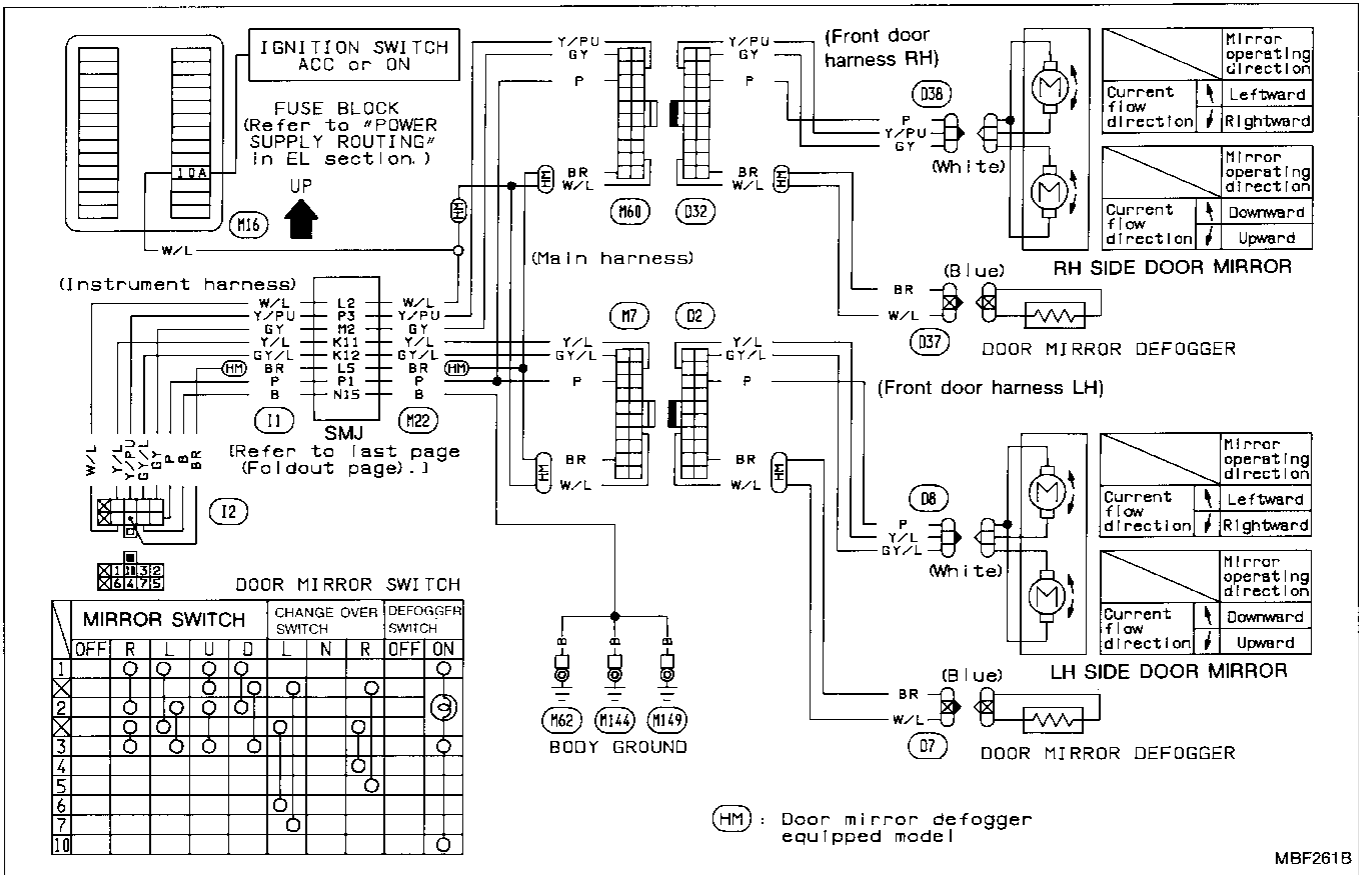

MBF261B

REAR COMBINATION LAMP AND REAR AIR SPOILER

Rear Combination Lamp

- Rear combination lamps are installed with nuts and butyl sealant.

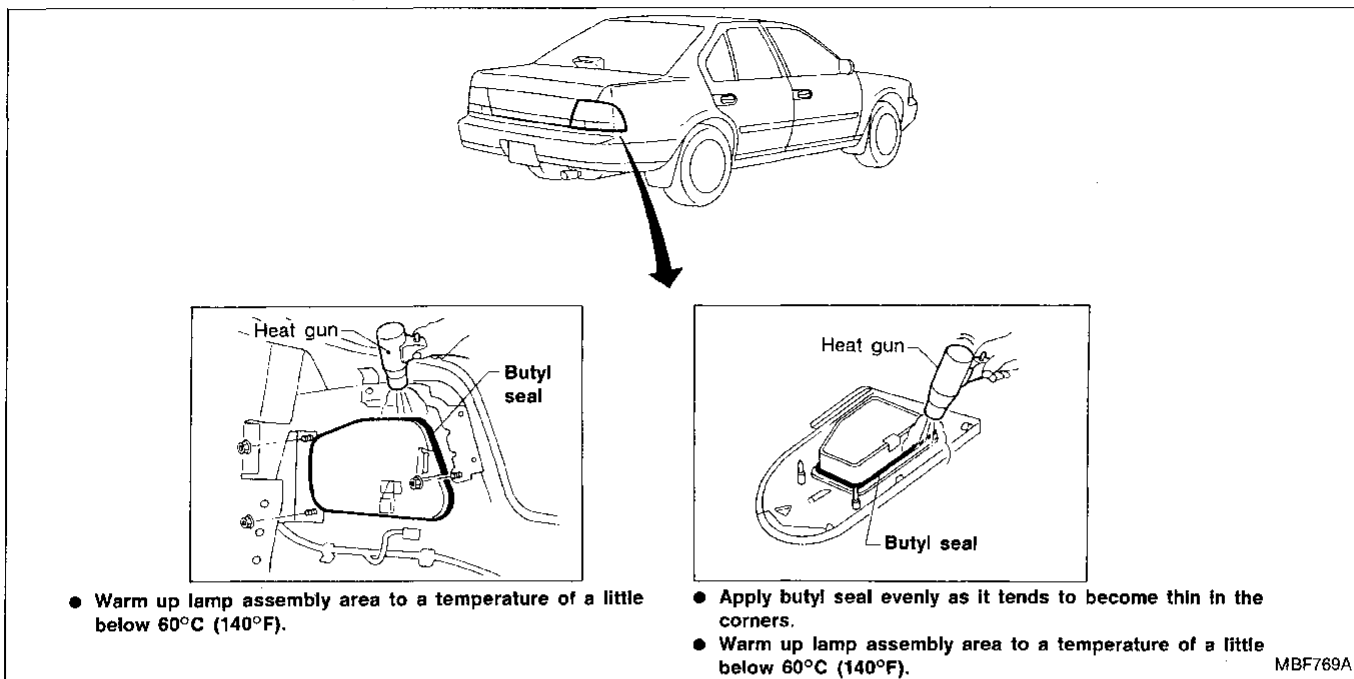

- When installing, make sure that there are not gaps or waves at ends of air spoiler.
- Before installing spoiler, clean and remove oil from surface where spoiler will be mounted.

Rear Air Spoiler

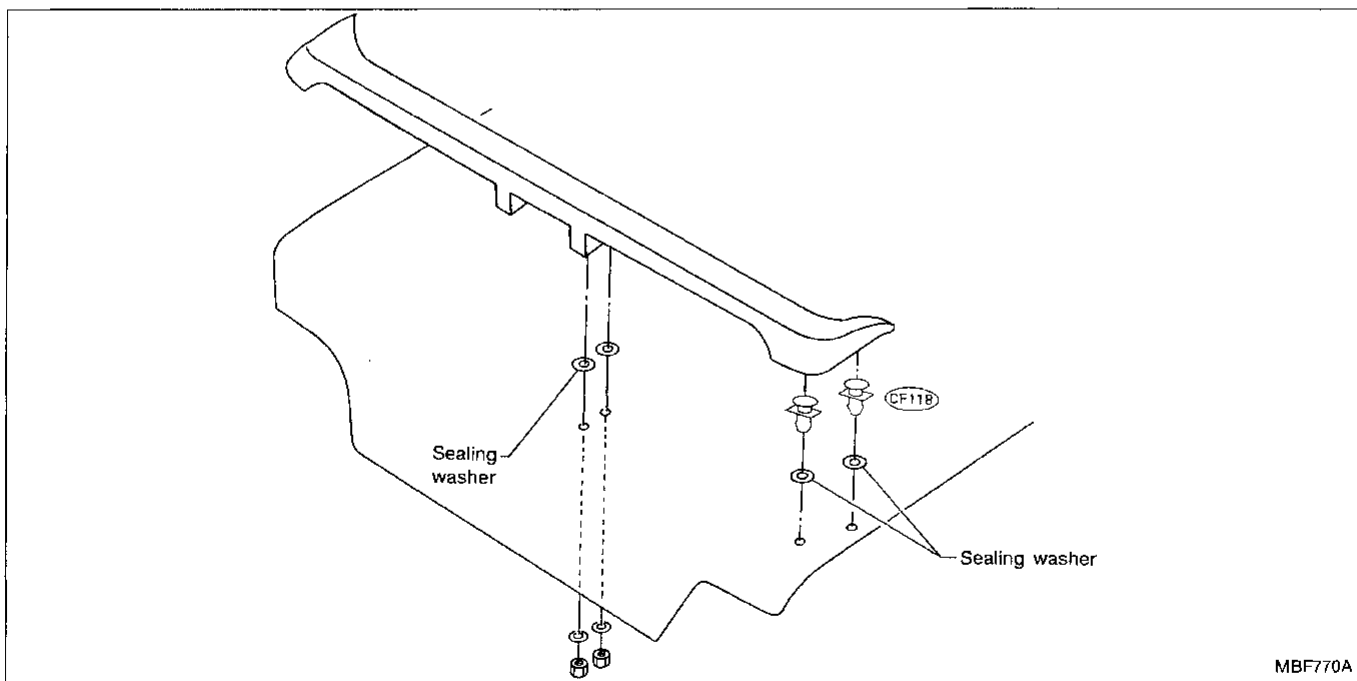

GI

MA

EM

LC

EF &
EC

FE

CL

MT

AT

FA

RA

BR

ST

BF

HA

EL

IDX

BODY ALIGNMENT

- All dimensions indicated in figures are actual ones.
- When a tram tracking gauge is used, adjust both pointers to equal length and check the pointers and gauge itself to make sure there is no free play.
- When a measuring tape is used, check to be sure there is no elongation, twisting or bending.
- Measurements should be taken at the center of the mounting holes.
- An asterisk (*) following the value at the measuring point indicates that the measuring point on the other side is symmetrically the same value.
- The coordinates of the measurement points are the distances measured from the standard line of "X", "Y" and "Z".

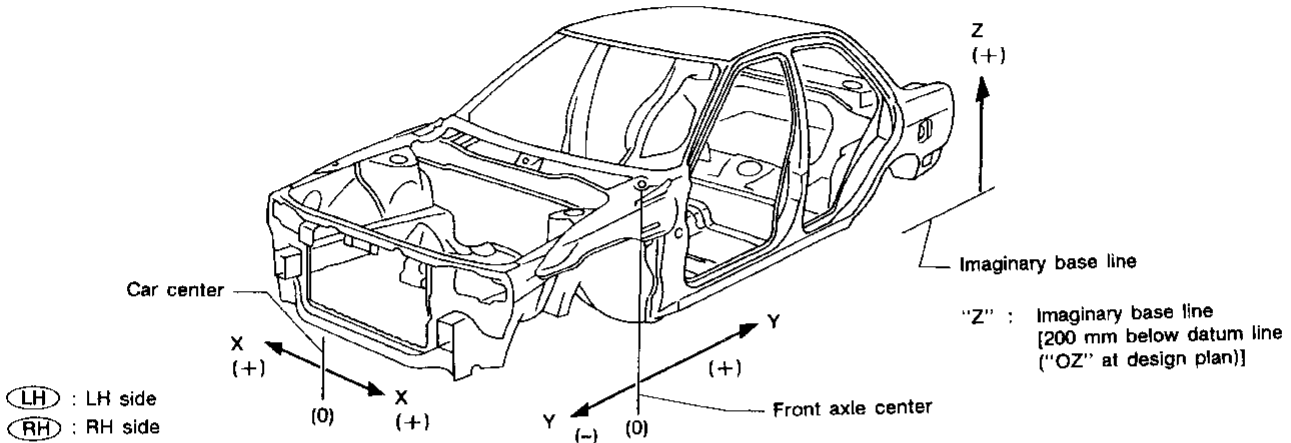

SBF874G

Engine Compartment

MEASUREMENT

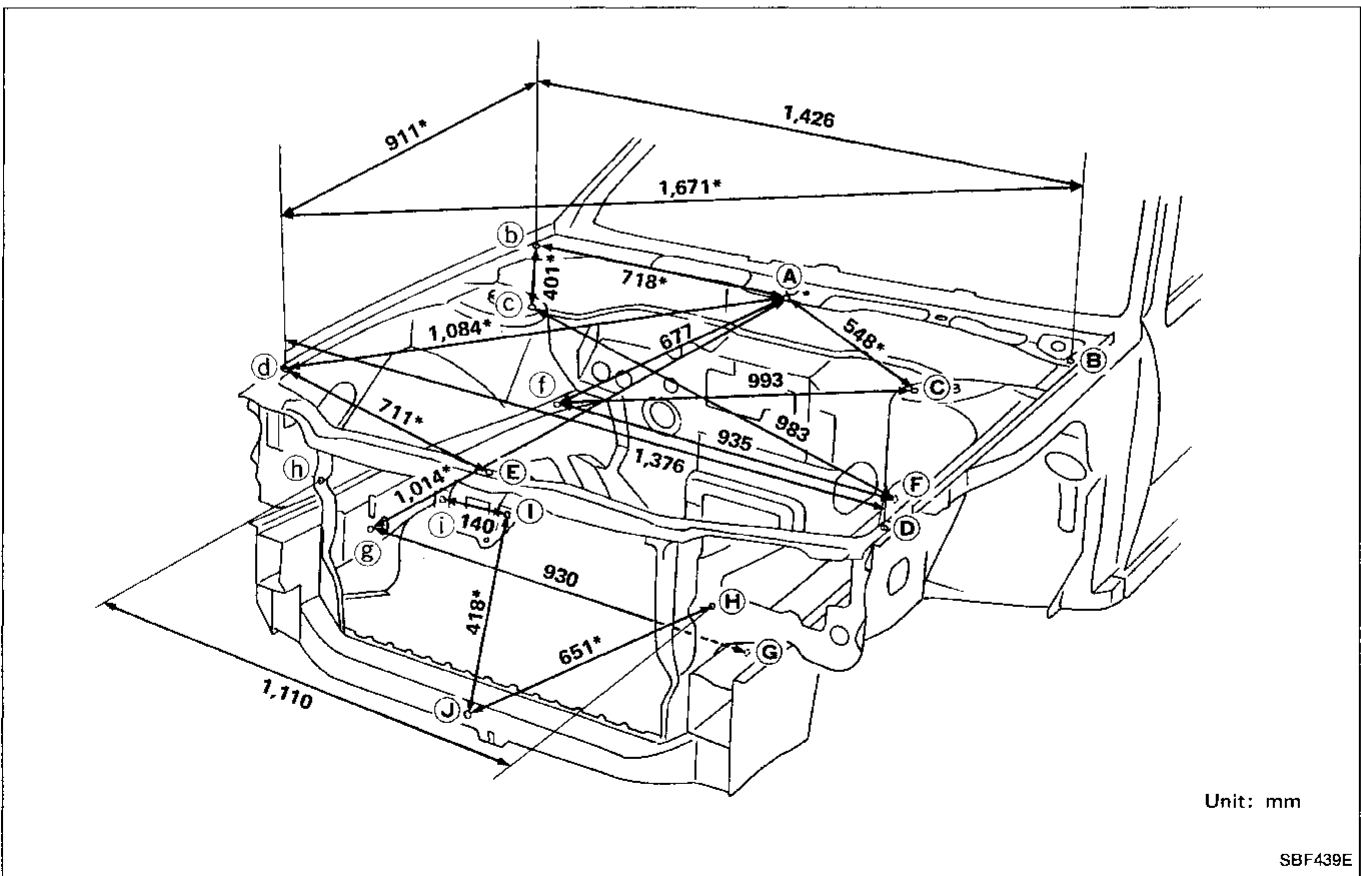

BODY ALIGNMENT

Engine Compartment (Cont'd)

MEASUREMENT POINTS

Unit: mm

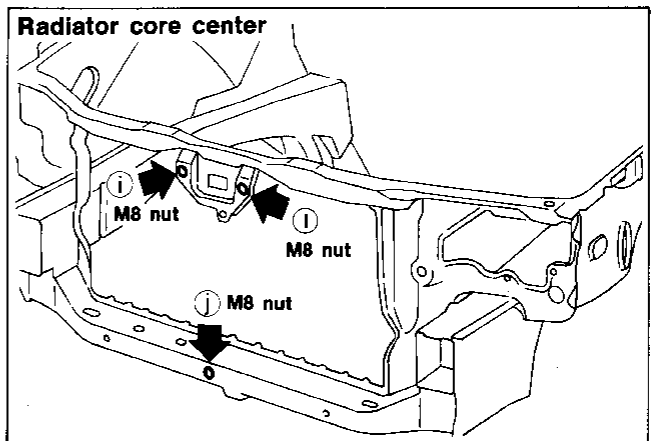
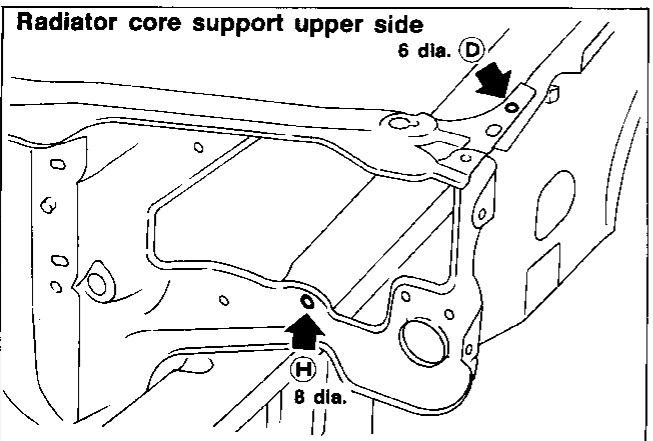
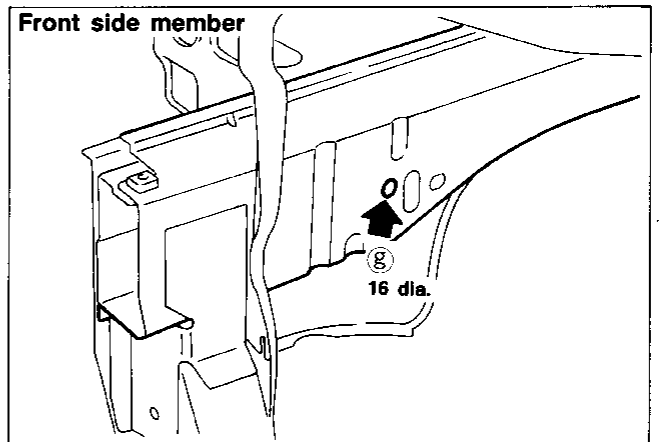
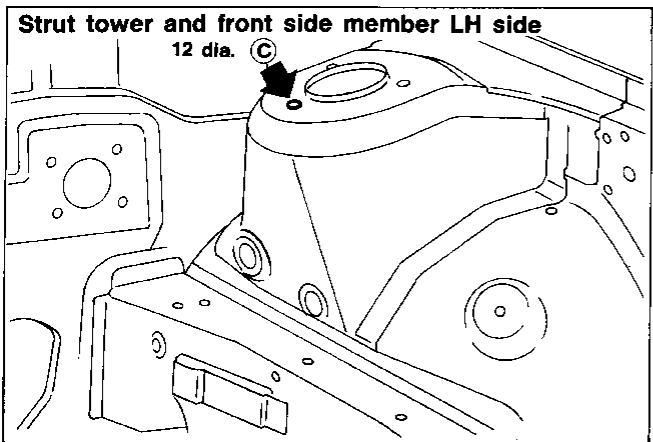
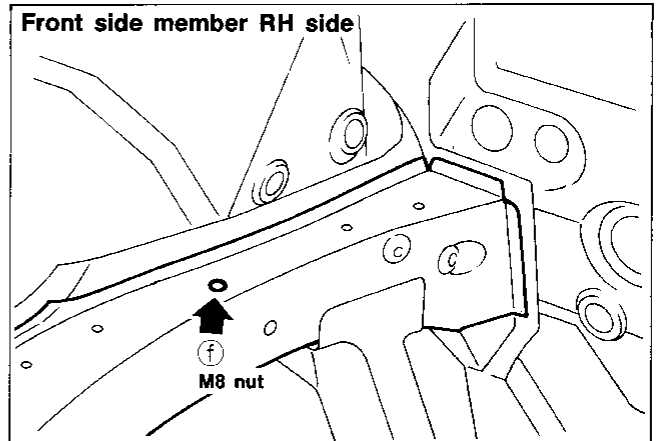
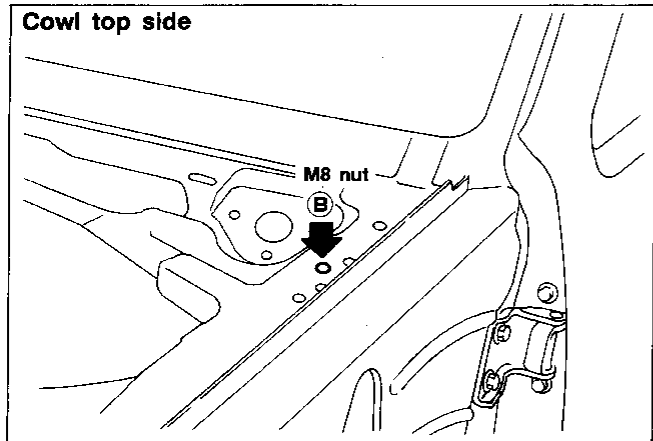
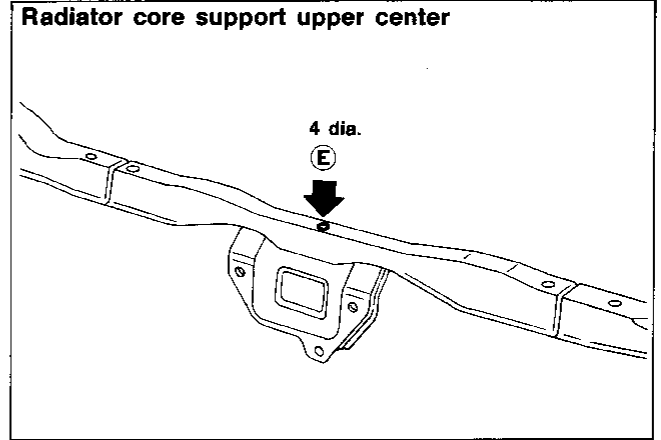
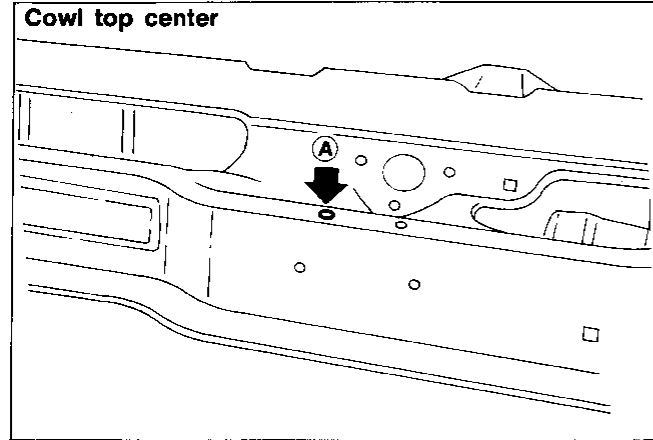

GI
MA
EM
LC
EF &
EC
FE
CL
MT
AT
FA
RA
BR
ST
BF
HA
EL
IDX

MBF425AA

BODY ALIGNMENT

Underbody

MEASUREMENT

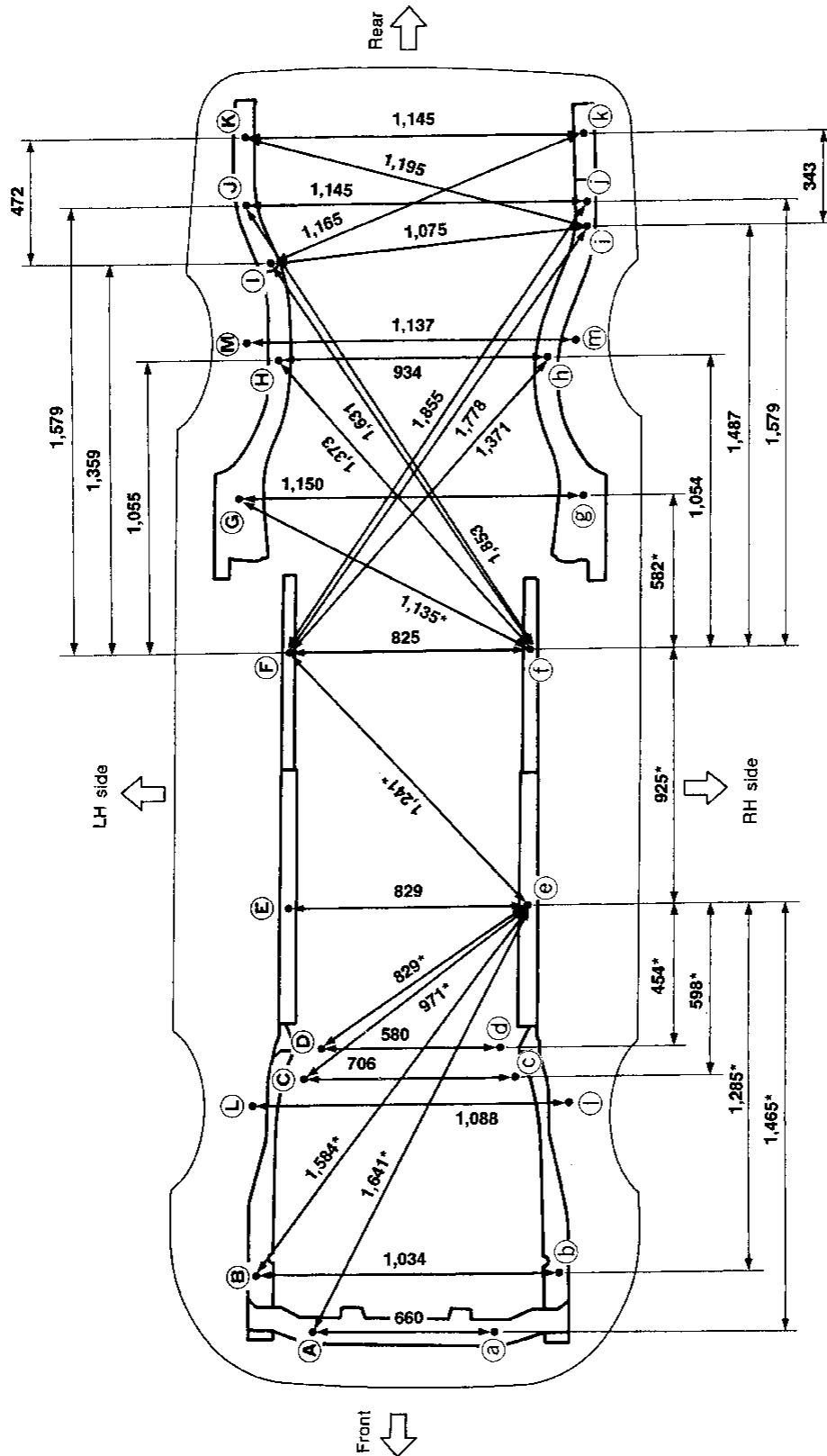

Unit: mm

All dimensions indicated in this figure are actual ones. (There are no projected dimensions.)

BODY ALIGNMENT

Underbody (Cont'd)

MEASUREMENT POINTS

Coordinates:

- (A), (a) X : 330
- Y : -760
- Z : 198.8
- (B), (b) X : 517
- Y : -560
- Z : 340
- (C), (c) X : 353
- Y : 106.2
- Z : 142.9
- (D), (d) X : 290
- Y : 266.9
- Z : 167.8
- (E), (e) X : 414.5
- Y : 700
- Z : 110

Coordinates:

- (F), (f) X : 412.5
- Y : 1,625
- Z : 108.8
- (G), (g) X : 575
- Y : 2,170
- Z : 234
- (H) X : 468
- Y : 2,655
- Z : 328
- (h) X : 466
- Y : 2,655
- Z : 328
- (I) X : 493
- Y : 2,964
- Z : 328
- (i) X : 575
- Y : 3,087
- Z : 328
- (J) X : 570
- Y : 3,180
- Z : 330
- (J) X : 575
- Y : 3,180
- Z : 330
- (K) X : 570
- Y : 3,430
- Z : 330
- (k) X : 575
- Y : 3,430
- Z : 330

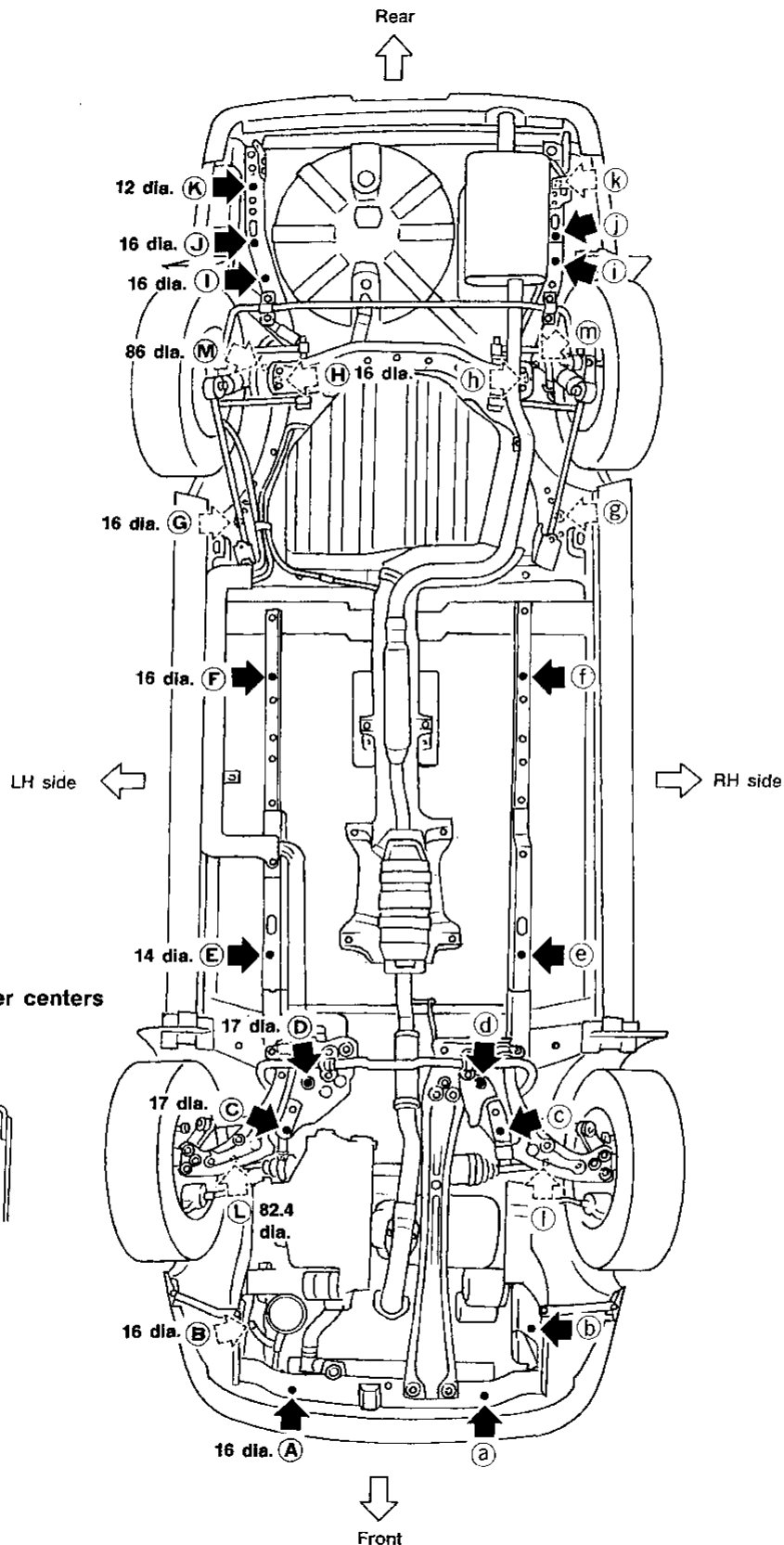

Front and rear strut lower centers

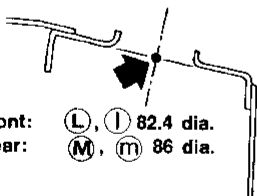

Front: (L), (l) 82.4 dia.
Rear: (M), (m) 86 dia.

Coordinates:

- (L), (l) X : 544
- Y : 13.5
- Z : 764.2
- (M), (m) X : 568.3
- Y : 2,699.1
- Z : 819.1

Unit: mm

- GI
- MA
- EM
- LC
- EF & EC
- FE
- CL
- MT
- AT
- FA
- RA
- BR
- ST
- BF**
- HA
- EL
- IDX

SUPPLEMENTAL RESTRAINT SYSTEM (SRS)



Precautions for SRS "Air Bag" Service

- Do not use a circuit tester to check SRS circuits.
- Before servicing the SRS, turn ignition switch "OFF", disconnect battery ground cable and wait for at least 10 minutes.
For approximately ten minutes after the cables are removed, it is still possible for the air bag to inflate. Therefore, do not work on any air bag system connectors or wires until at least ten minutes have passed.
- SRS sensors must always be installed with their arrow marks "↔" facing the front of the vehicle for proper operation. Also check sensors for cracks, deformities or rust before installation and replace as required.
- The spiral cable must be aligned with the neutral position since its rotations are limited. Do not attempt to turn steering wheel or column after removal of steering gear.
- Handle air bag module carefully. Always place it with the pad side facing upward.
- After removing any SRS parts, discard old bolts and replace with new ones. Conduct self-diagnosis to check entire SRS for proper function.
- If front of vehicle is damaged in a collision, always check the crash zone sensor and the wiring harness.

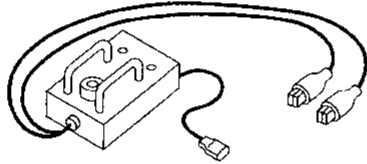
Special Service Tool

Tool number (Kent-Moore No.) Tool name	Description	
KV999R0011 (J38381) Deployment tool		Disposing of air bag module
	NT219	

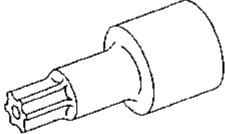
Commercial Service Tools

Tool name	Description	
Special torx bit		Use for special bolts (tamper resistant screw)
	NT220	
Spiral cable stopper		Avoiding unexpected spiral cable rotation
	NT221	

SUPPLEMENTAL RESTRAINT SYSTEM (SRS)

Description

The air bag deploys when any of the two sensors (front crash zone sensor or tunnel sensor) and the safing sensor simultaneously activate while the ignition switch is "ON".

Ignition	Crash zone sensor	Tunnel sensor	Safing sensor	Air bag signal
	Front			
ON	ON		ON	ON
ON		ON	ON	ON

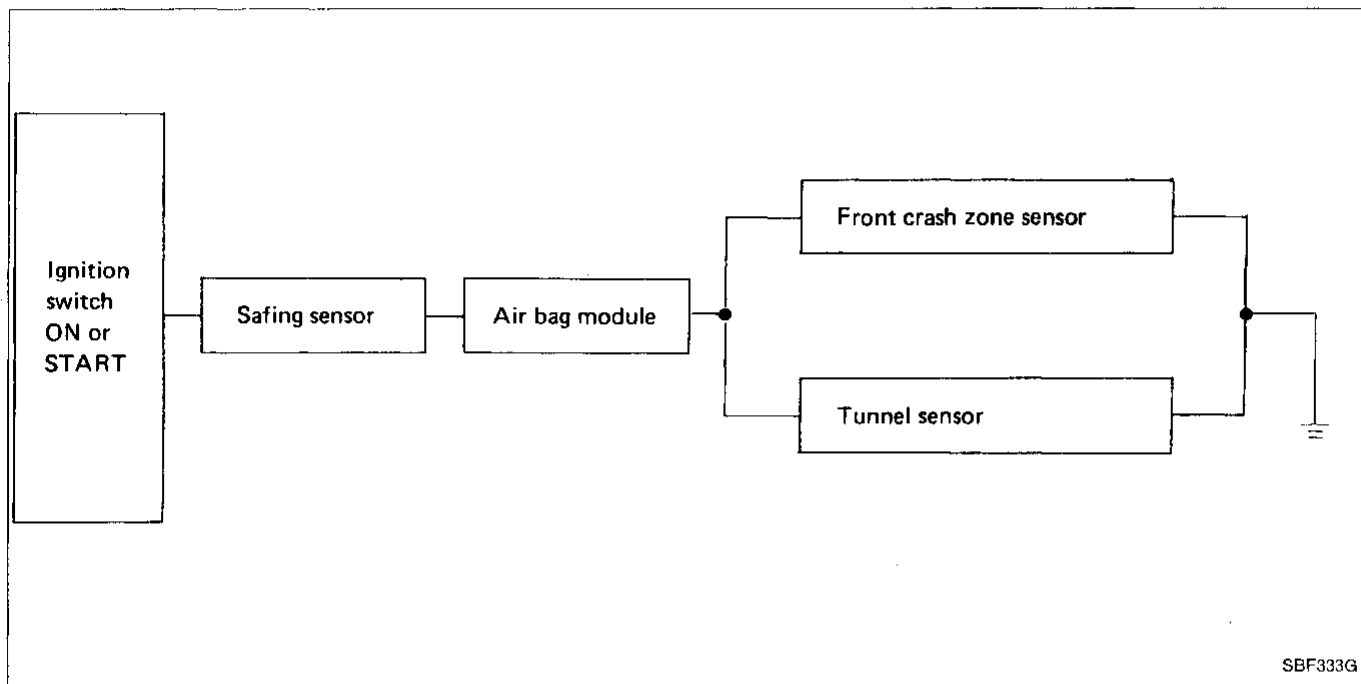

Self-diagnosis

The diagnosis unit (control unit) diagnoses the SRS circuit. When the ignition key is in the "ON" or "START" position, the "AIR BAG" warning lamp will illuminate for about 7 seconds and then turn off. This means that the system is operational.

GF
MA
EM
LC
EF & EC
FE
CL
MT
AT
FA
RA
BR
ST
BF
HA
EL
IDX

SUPPLEMENTAL RESTRAINT SYSTEM (SRS)

SRS Component Parts Location and Caution Labels

The CAUTION LABELS are important when servicing air bags in the field. If they are dirty or damaged, replace them with new ones.

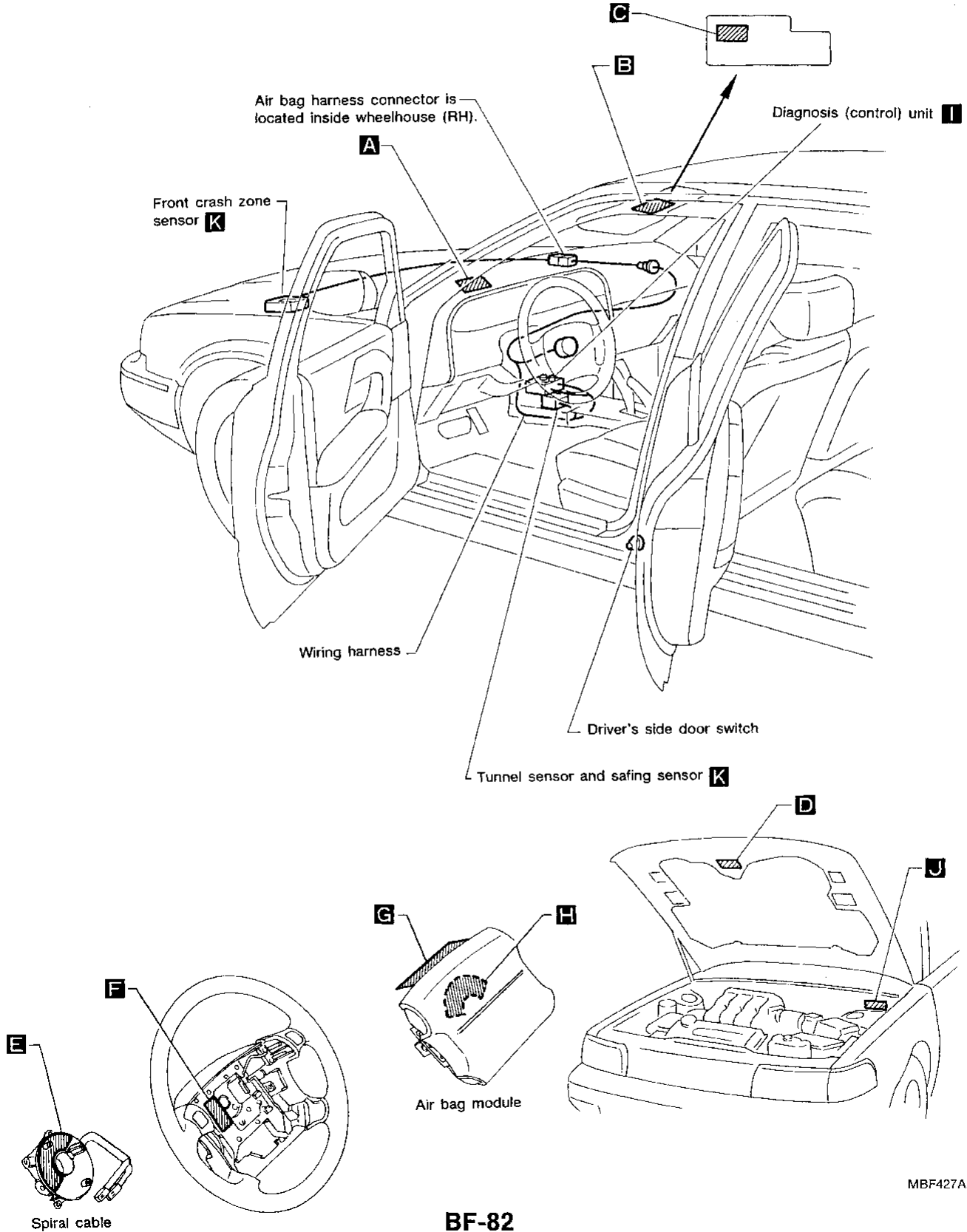

SUPPLEMENTAL RESTRAINT SYSTEM (SRS)

Caution Labels

A

DRIVER-AIRBAG

B

INFORMATION SRS AIRBAG

- THIS CAR IS EQUIPPED WITH A DRIVER AIR BAG AS A SUPPLEMENTAL RESTRAINT SYSTEM (S.R.S.) TO HELP PROTECT THE DRIVER IN A FRONTAL COLLISION.
- ALWAYS WEAR YOUR SEAT BELT.
- THE SYSTEM MUST BE INSPECTED 10 YEARS AFTER DATE OF MANUFACTURE, AS NOTED ON THE CERTIFICATION LABEL LOCATED ON THE LEFT FRONT DOOR.
- IF ANY OF THE FOLLOWING CONDITIONS OCCUR, THE SYSTEM MUST BE SERVICED: THE "AIR BAG" LAMP DOES NOT GO ON, FLASHES INTERMITTENTLY OR REMAINS ON.
- SEE YOUR OWNER'S MANUAL FOR DETAILS ABOUT THE FUNCTIONING, SERVICE, AND DISPOSAL PROCEDURES FOR THE SYSTEM.

IMPORTANT SAFETY INFORMATION FOR YOU AND YOUR PASSENGER AUTOMATIC SHOULDER BELT AND MANUAL LAP BELT RESTRAINT SYSTEM

- ALWAYS USE MANUAL LAP BELT: Failure to do so may decrease the protection offered by the restraint system.
- DO NOT DISCONNECT THE EMERGENCY RELEASE FOR NORMAL DRIVING: This feature is for emergency use only.
- REFER TO OWNER'S MANUAL FOR OTHER IMPORTANT SAFETY INFORMATION ON:
 1. Proper seating position and use of restraint system
 2. Release of shoulder belt in an emergency
 3. Use of hand crank for shoulder belt
 4. Use by children

C

NOTICE SRS AIRBAG

- THIS CAR IS EQUIPPED WITH A DRIVER AIR BAG AS A SUPPLEMENTAL RESTRAINT SYSTEM (S.R.S.)
- IT IS DESIGNED TO SUPPLEMENT THE SEAT BELT.
- ALWAYS WEAR YOUR SEAT BELT.

D

WARNING SRS AIRBAG

- THIS CAR IS EQUIPPED WITH A DRIVER AIR BAG AS A SUPPLEMENTAL RESTRAINT SYSTEM (S.R.S.)
- ALL S.R.S. ELECTRICAL WIRING AND CONNECTORS ARE COLORED YELLOW.
- DO NOT USE ELECTRICAL TEST EQUIPMENT ON THESE CIRCUITS.
- TAMPERING WITH OR DISCONNECTING THE S.R.S. WIRING AND CONNECTORS COULD RESULT IN ACCIDENTAL DEPLOYMENT OF THE AIR BAG OR MAKE THE SYSTEM INOPERATIVE, WHICH MAY RESULT IN SERIOUS INJURY.

E

CAUTION SRS AIRBAG

- BEFORE ASSEMBLY;
 - LINE UP THE FRONT WHEELS STRAIGHT AHEAD.
 - ALIGN THE ARROW WITH THE YELLOW MARK ON THE SIDE GEAR.
 - READ SERVICE MANUAL.
- NO SERVICEABLE PARTS INSIDE.
- DO NOT DISASSEMBLE OR TAMPER.

F

WARNING SRS AIRBAG

BEFORE MOUNTING STEERING WHEEL;

- MAKE SURE THAT THE FRONT WHEELS ARE IN STRAIGHT-AHEAD POSITION.
- ALIGN THE ARROW WITH THE YELLOW MARK ON THE SIDE GEAR. (SPIRAL CABLE)
- READ SERVICE MANUAL.

GI

MA

EM

LC

EF & EC

FE

CL

MT

AT

FA

RA

BR

ST

BF

HA

EL

DX

SUPPLEMENTAL RESTRAINT SYSTEM (SRS)

Caution Labels (Cont'd)

G

WARNING

SRS AIRBAG

- THIS AIR BAG MODULE CANNOT BE REPAIRED.
- USE DIAGNOSTIC INSTRUCTIONS TO DETERMINE IF THE UNIT IS OPERATIONAL.
- IF NOT OPERATIONAL, REPLACE AND DISPOSE OF THE ENTIRE UNIT AS DIRECTED IN THE INSTRUCTIONS.
- UNDER NO CIRCUMSTANCES SHOULD A DIAGNOSIS BE PERFORMED USING ELECTRICALLY POWERED TEST EQUIPMENT OR PROBING DEVICES.
- TAMPERING OR MISHANDLING CAN RESULT IN PERSONAL INJURY.
- STORE THE REMOVED AIR BAG MODULE WITH THE PAD SURFACE UP.
- FOR SPECIAL HANDLING OR STORAGE REFER TO SERVICE MANUAL.

I

CAUTION SRS AIRBAG

- NO SERVICEABLE PARTS INSIDE.
- DO NOT DISASSEMBLE OR TAMPER.
- DO NOT DROP; KEEP DRY.
- WHILE REMOVED, STORE IN A CLEAN AND DRY AREA.
- IF WET CONDITION OCCURS, THIS UNIT MUST BE SERVICED.

J

CAUTION SRS AIRBAG

- TO AVOID DAMAGING THE S.R.S. SPIRAL CABLE, REMOVE THE STEERING WHEEL BEFORE REMOVING THE STEERING LOWER JOINT.

H

DANGER POISON

- KEEP OUT OF THE REACH OF CHILDREN.
- CONTAINS SODIUM AZIDE AND POTASSIUM NITRATE.
- CONTENTS ARE POISONOUS AND EXTREMELY FLAMMABLE.
- CONTACT WITH ACID, WATER OR HEAVY METALS MAY PRODUCE HARMFUL AND IRRITATING GASES OR EXPLOSIVE COMPOUNDS.
- DO NOT DISMANTLE, INCINERATE, OR BRING INTO CONTACT WITH ELECTRICITY OR STORE AT TEMPERATURES EXCEEDING 200°F.
- FIRST AID: IF CONTENTS ARE SWALLOWED, INDUCE VOMITING;
 - FOR EYE CONTACT, FLUSH EYES WITH WATER FOR 15 MINUTES
 - IF GASES FROM ACID OR WATER CONTACT ARE INHALED, SEEK FRESH AIR
 - IN EVERY CASE, GET PROMPT MEDICAL ATTENTION
- FOR ADDITIONAL INFORMATION, SEE MATERIAL SAFETY DATA SHEET (MSDS) FOR THIS PRODUCT.

K

WARNING

SRS AIRBAG

- DO NOT DISASSEMBLE OR TAMPER.
- DISMANTLING AND INSTALLATION SHOULD ONLY BE PERFORMED BY TRAINED PERSONNEL.

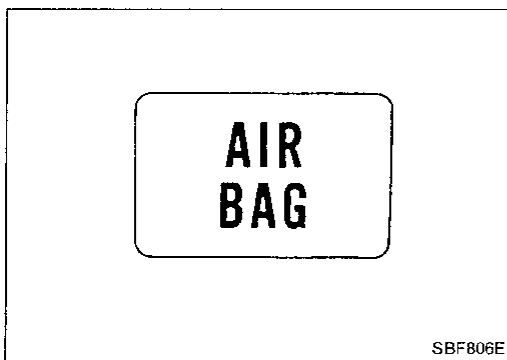

Maintenance Items

1. Check "AIR BAG" warning lamp
When the ignition key is in the "ON" or "START" position, the "AIR BAG" warning lamp will illuminate for about 7 seconds and then turn off. This means that the system is operational. GI
2. Visually check SRS components MA
 - (1) Sensors EM
 - Check sensors to ensure the arrow marks face the front of the vehicle. LC
 - Check body and sensor brackets for deformities or rust. EF & EC
 - Check sensor case for dents, cracks, deformities or rust. FE
 - Check sensor harness for binds, connector for damage, and terminals for deformities. CL
 - (2) Diagnosis (Control) unit — Airbag MT
 - Check case and bracket for dents, cracks or deformities. AT
 - Check connectors for damage, and terminals for deformities. FA
 - (3) Main harness and instrument harness RA
 - Check connectors for poor connections. BR
 - Check harnesses for binds, connectors for damage, and terminals deformities. ST
 - (4) Spiral cable BF
 - Visually check lock (engagement) pins and combination switch for damage. HA
 - Check connectors, flat cable and protective tape for damage. EL
 - Check steering wheel for noise, binds or difficult operation. DX
 - (5) Steering wheel ST
 - Check harness (built into steering wheel) and connectors for damage, and terminals for deformities. BR
 - Install air bag module to check fit or alignment with steering wheel. ST
 - Check steering wheel for excessive free play. RA
 - (6) Air bag module BR
 - Remove air bag module from steering wheel. ST
 - Check harness cover and connectors for damage, terminals for deformities, and harness for binds. BR
 - Install air bag module to steering wheel to check fit or alignment with the wheel. ST

CAUTION:

Replace previously used screws with new ones.

BF

HA

EL

DX

Removal and Installation — Diagnosis (Control) Unit and Sensors

CAUTION:

- Before servicing SRS, turn the ignition switch off, disconnect battery ground cable and wait for at least 10 minutes.
- The special bolts are coated with bonding agent. Discard old ones after removal; replace with new ones.
- Check all sensors for proper installation.
- Check all sensors to ensure they are free of deformities, dents, cracks or rust. If they show any visible signs of damage, replace them with new ones.
- Check sensor brackets to ensure they are free of deformities or rust.

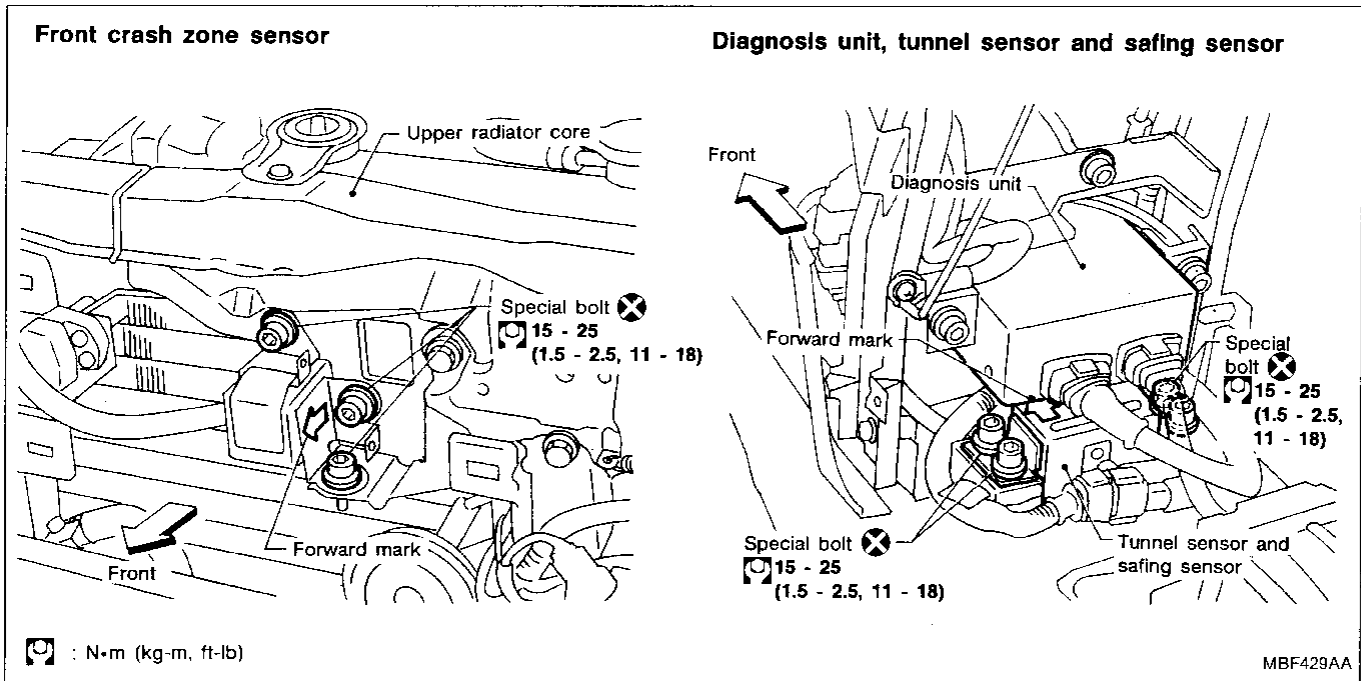

Removal — Air Bag Module and Spiral Cable

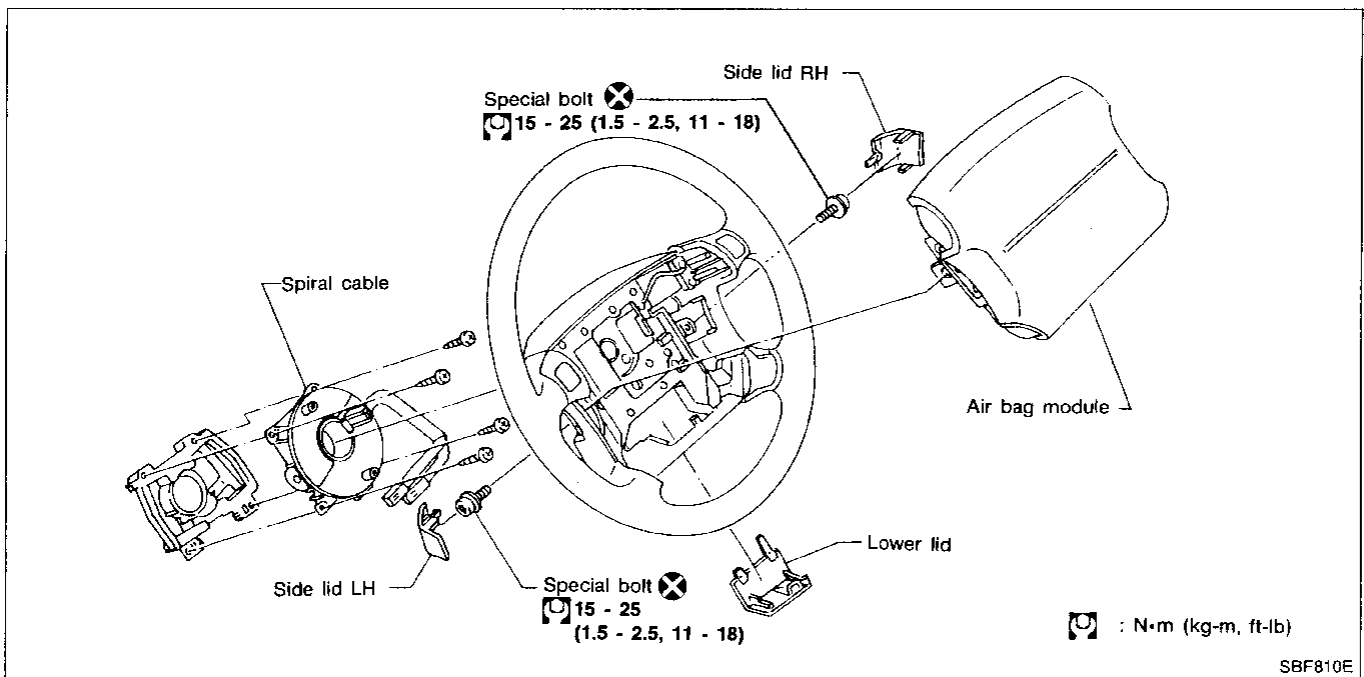

SUPPLEMENTAL RESTRAINT SYSTEM (SRS)

Removal — Air Bag Module and Spiral Cable (Cont'd)

CAUTION:

Before servicing SRS, turn the ignition switch off, disconnect battery ground cable and wait for at least 10 minutes.

1. Remove lower lid from steering wheel, and disconnect air bag module connector. CI

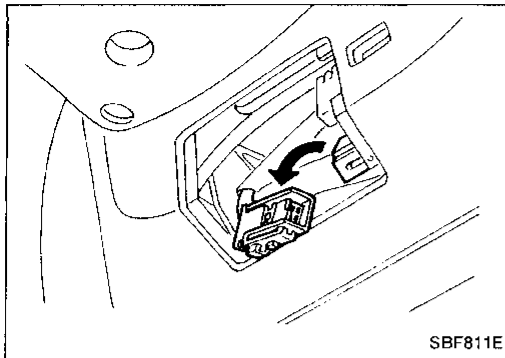

2. Remove side lid. Using the T50H torx bit, remove left and right special bolts. Air bag module can then be removed. MA
EM
LC

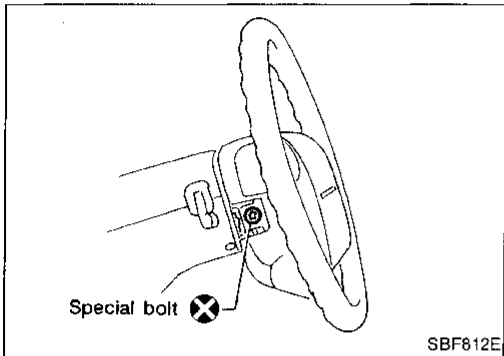

CAUTION:

- Always place air bag module with pad side facing upward. EF & EC
- Do not attempt to disassemble air bag module. FE
- The special bolts are coated with bonding agent. Discard old ones after removal; replace with new ones. CL

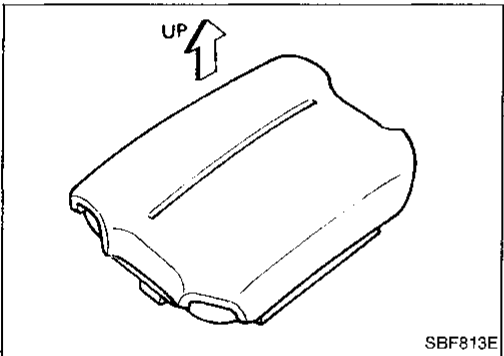

- Do not drop or impact air bag module. If any portion is deformed or cracked, replace the module. MT
- Do not expose the air bag module to temperatures exceeding 100°C (212°F). AT
- Do not allow oil, grease or water to come in contact with the air bag module. FA

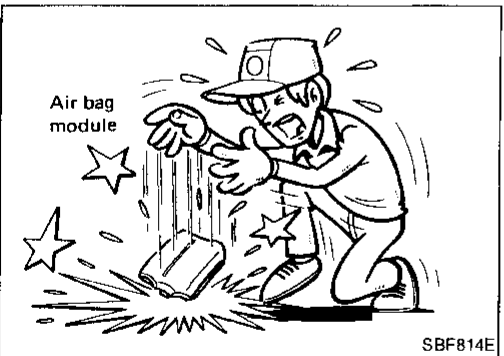

3. Set steering wheel in the neutral position. RA
4. Disconnect horn connector and remove nuts. BR
5. Using steering wheel puller, remove steering wheel. Be careful not to over-tighten puller bolt on steering wheel. ST

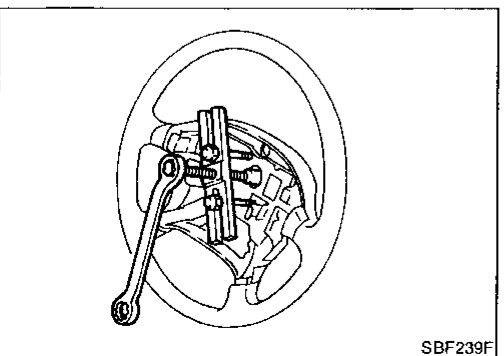

BF

HA

EL

IDX

SUPPLEMENTAL RESTRAINT SYSTEM (SRS)

Removal — Air Bag Module and Spiral Cable (Cont'd)

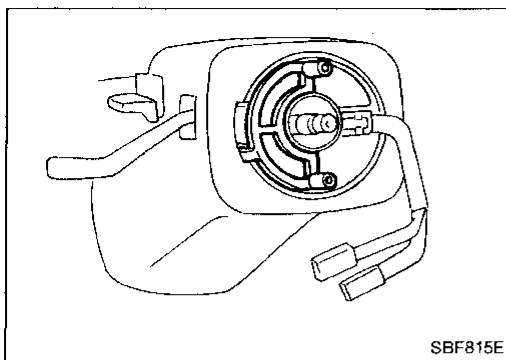

6. Attach spiral cable to stopper.
7. Remove steering column cover.
8. Disconnect connector and remove the four screws. The spiral cable can then be removed.

Installation — Air Bag Module and Spiral Cable

1. Connect spiral cable connector and tighten with screws. Install steering column cover.

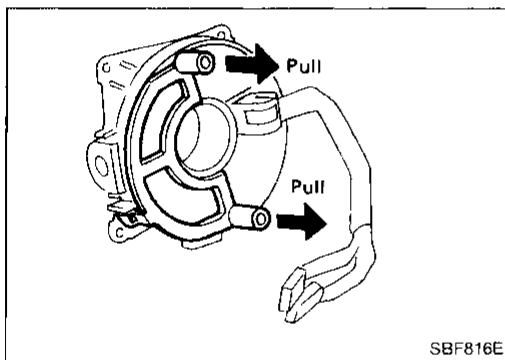

2. Remove stopper by pulling two pin guides.

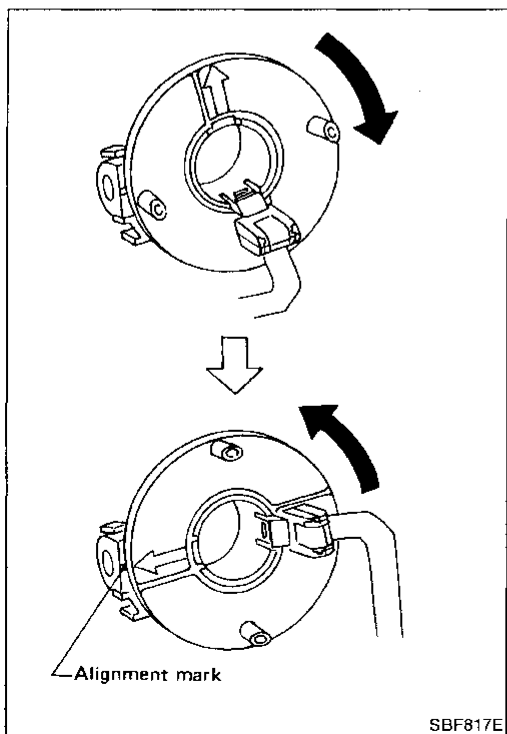

- Alignment of spiral cable with neutral position
If stopper is not used, align spiral cable with neutral position as follows:
Turn spiral cable clockwise until it catches stopper. Then, back spiral cable off approximately two turns until yellow alignment mark appears on left gear. Align arrow mark "←" of spiral cable with this yellow mark.

SUPPLEMENTAL RESTRAINT SYSTEM (SRS)

Installation — Air Bag Module and Spiral Cable (Cont'd)

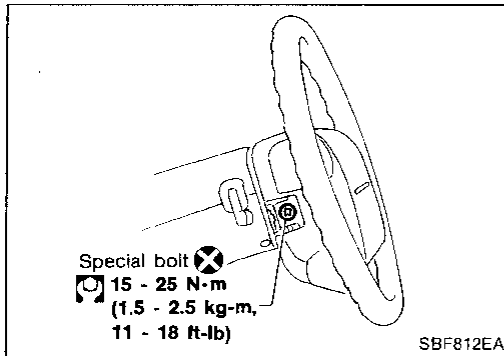
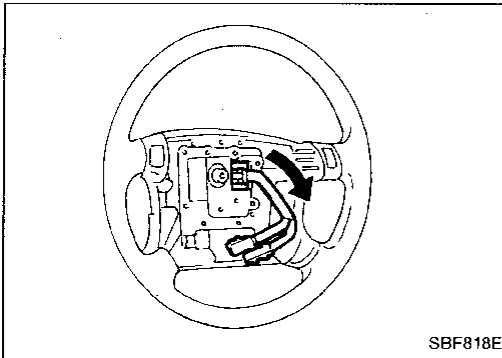

3. Install steering wheel setting spiral cable pin guides, and pull spiral cable through.
4. Connect horn connector and engage spiral cable with pawls in steering wheel.
5. Tighten nuts.
6. Position air bag module and tighten with new special bolts.
7. Connect air bag module connector.
8. Install all lids.
9. Conduct self-diagnosis to ensure entire SRS operates properly. (Use CONSULT or warning lamp check.)

GI

MA

EM

LC

EF &
EC

FE

CL

MT

AT

FA

RA

BR

ST

BF

HA

EL

FX

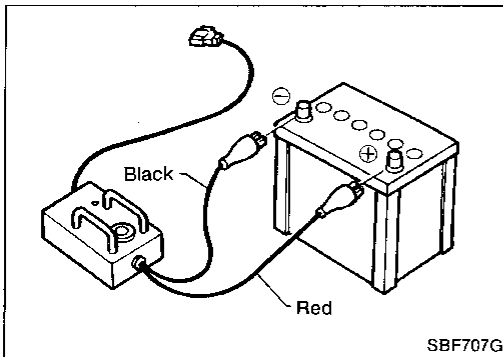

Scrapping the Air Bag

Before scrapping an air bag module or a vehicle equipped with an SRS air bag, be sure to deploy air bag.

CONNECTING TO BATTERY

- Place the vehicle outdoors in such a way that it is surrounded on all sides by at least 6 m (20 ft) of open space.
- Use a voltmeter to make sure the vehicle battery is fully charged.

CAUTION:

The battery must show voltage of 9.6V or more.

Remove the battery from the vehicle and place it on dry wood blocks approximately 5 m (16 ft) away from the vehicle.

- Wait 10 to 12 minutes after the vehicle battery is disconnected before proceeding.
- Connect deployment tool to the battery.

CAUTION:

Make sure the polarity is correct. The right side lamp in the tool, marked "deployment tool power", should glow with a green light. If the right side lamp glows red, reverse the connections to the battery.

SUPPLEMENTAL RESTRAINT SYSTEM (SRS)

Scrapping the Air Bag (Cont'd)

DEPLOYMENT TOOL CHECK

Press the deployment tool switch to the "ON" position. The left side lamp in the tool, marked "air bag connector voltage" should illuminate. If it does not illuminate, replace the tool.

AIR BAG DEPLOYMENT TOOL LAMP ILLUMINATION CHART (Battery connected)

Switch operation	Left side lamp, green* "AIR BAG CONNecTOR VOLTAGE"	Right side lamp, green* "DEPLOYMENT TOOL POWER"
OFF	OFF	ON
ON	ON	ON

*: If this lamp glows red, the tool is connected to the battery incorrectly. Reverse the connections and make sure the lamp glows green.

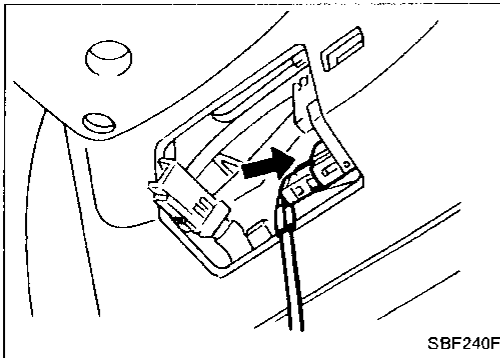
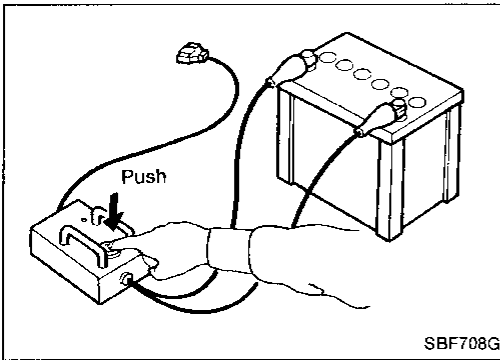

CONNECTING TO AIR BAG

- Remove lower lid from steering wheel and disconnect air bag module connector.
- Connect deployment tool connector.

CAUTION:

Make sure the deployment tool is disconnected from the battery before you make this connection.

- Reconnect the battery cable to the prepared battery.
- The lamp on the right side of the tool, marked "deployment tool power", should glow green, not red.

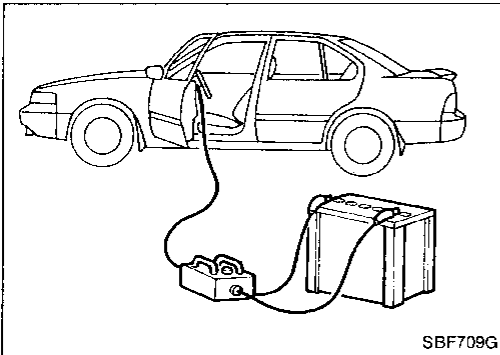

DEPLOYMENT

Press the button on the deployment tool. The left side lamp on the tool, marked "air bag connector voltage", will illuminate and the air bag will deploy.

DISPOSAL

- Remove steering wheel side lids. Use the special "torx" bit to remove the air bag module from the steering wheel. Place it into a sealed vinyl bag for disposal.

CAUTION:

- **When deploying air bag, ensure vehicle is empty.**
- **No poisonous gas is produced upon air bag deployment. However, be careful not to inhale gas since it irritates throat and can cause choking.**
- **Due to heat, leave air bag module unattended for more than 30 minutes after air bag deployment.**
- **Do not attempt to disassemble air bag module.**
- **Air bag module can not be re-used.**
- **Never apply water to a deployed air bag module.**
- **Be sure to wear gloves when handling a deployed air bag module.**

Contents

Schematic BF- 91

Wiring Diagram BF- 92

Self-diagnosis

USING CONSULT BF- 93

USING THE WARNING LAMP BF- 95

Diagnostic Procedure 1 BF- 98

SYMPTOM: Warning lamp flashes.

Diagnostic Procedure 2 BF- 98

SYMPTOM: Warning lamp does not come on.

Diagnostic Procedure 3 BF- 99

SYMPTOM: Warning lamp does not go off.

Collision Diagnosis BF-100

Schematic

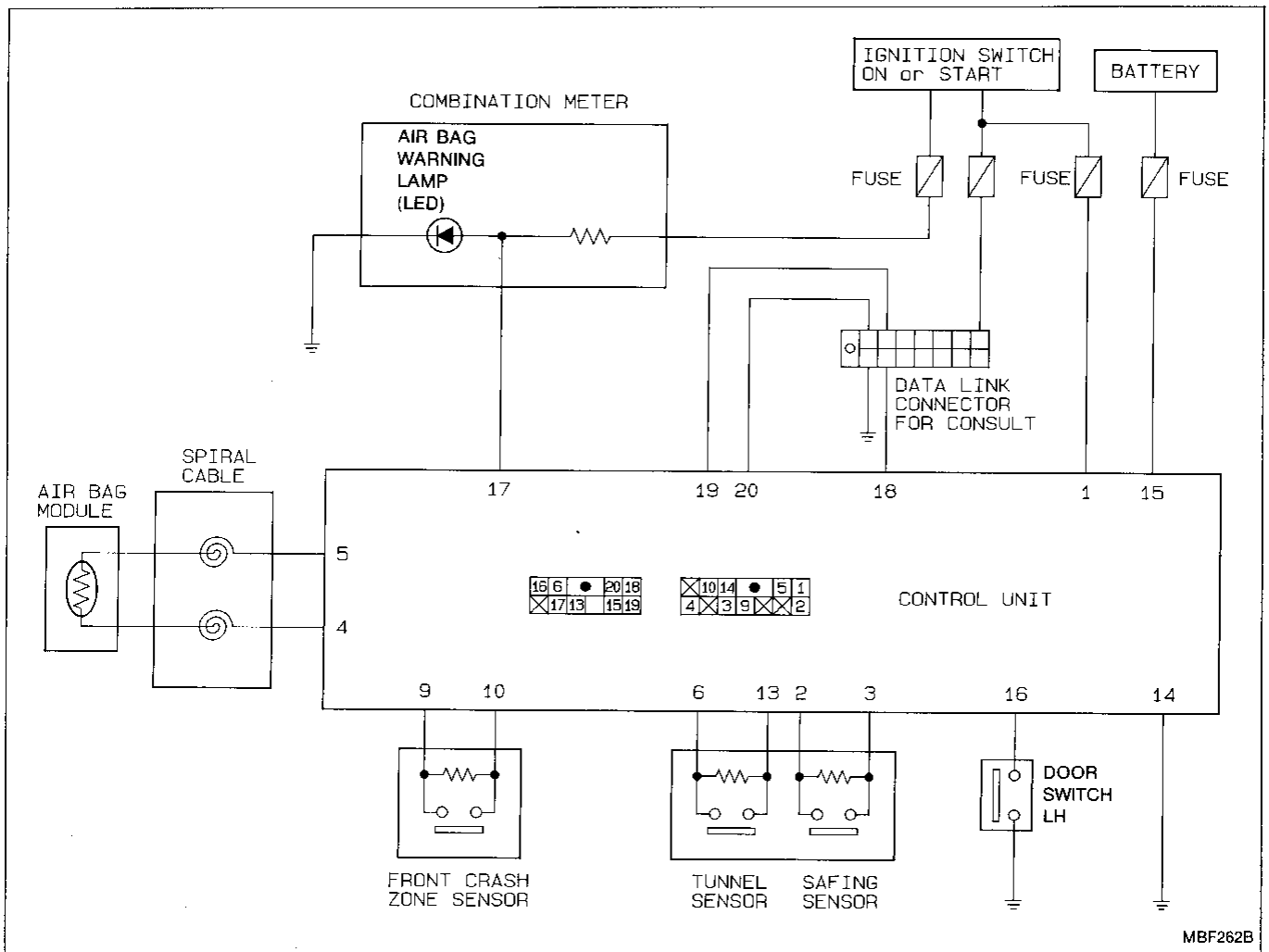

Wiring Diagram

CAUTION:

- Do not use a circuit tester to check SRS "Air Bag" harness connectors. The wiring harness and connectors have yellow outer insulation for easy identification.
- Do not attempt to repair, splice or modify the SRS "Air Bag" wiring harness. If the harness is damaged, replace it with a new one.
- Keep ground portion clean.

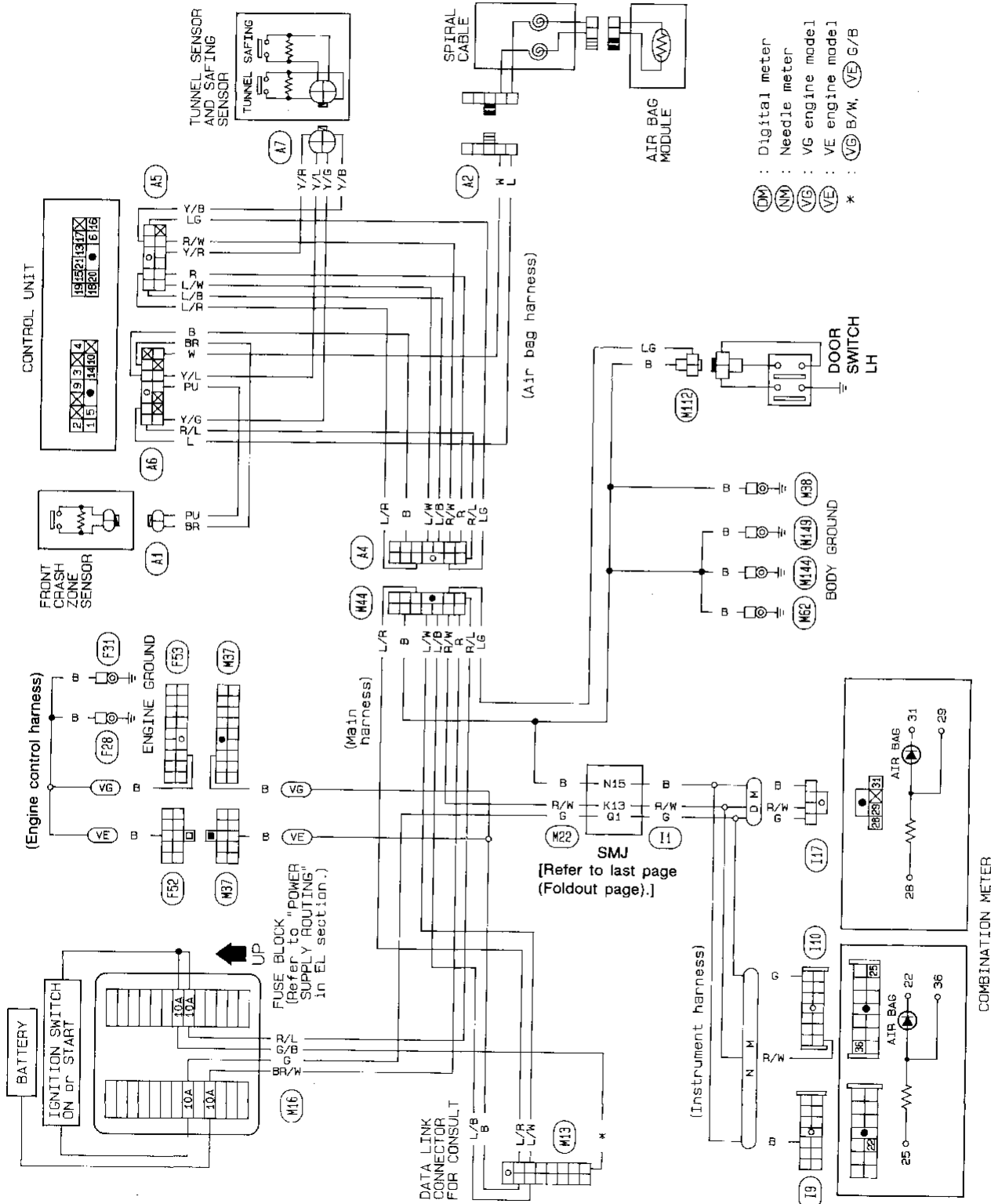

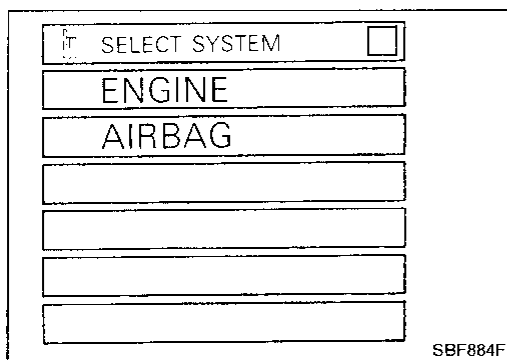
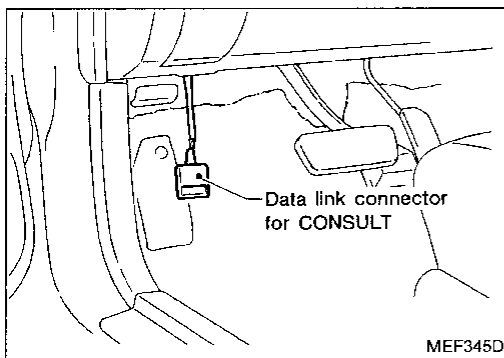

Self-diagnosis

USING CONSULT

The self-diagnosis results can be read by CONSULT, as follows:

1. Connect "CONSULT" to data link connector for CONSULT. (Data link connector for CONSULT is located in the fuse box.)



2. Turn ignition switch to "ON". (When CONSULT is connected, the "AIR BAG" warning lamp will be turned to present diagnosis mode.)



3. Touch "START" to operate "CONSULT".



4. Touch "AIR BAG" to choose air bag system.



5. Touch "SELF DIAG RESULTS" to read self-diagnosis results.



6. Problem codes are displayed on "SELF DIAG RESULT 1" (first page — present mode). The problem code last indicated is displayed on "SELF DIAG RESULT 2" (second page — initial mode).



7. When "PRINT" is pressed, information displayed on "SELF DIAG RESULTS 1 and 2" is printed out.



8. After repairing malfunctioning parts, press "ERASE" to clear self-diagnosis results.

- **After repairing malfunctioning parts, attempt to clear self-diagnosis results from memory.**
- **If malfunctioning parts are not completely repaired, self-diagnosis results remain stored in memory.**



9. Push Back Key of CONSULT until SELECT SYSTEM mode appears to make "SELF-DIAGNOSIS" user mode.



10. Push the power off switch.



11. Turn off ignition switch.

GI

MA

EM

LC

EF &
EC

FE

CL

MT

AT

FA

RA

BR

ST

BF

HA

EL

IDX

TROUBLE DIAGNOSES — Supplemental Restraint System (SRS)

Self-diagnosis (Cont'd)

Self-diagnosis results

Diagnostic item [Present] and [Initial]	Explanation	Repair order * Recheck SRS at each replacement.
NO SELF DIAGNOSTIC FAILURE INDICATED	Normal. The SRS "Air Bag" is in good order.	—
SAFING SENSOR [OPEN/LWR-GND-SHORT]	The circuit for the safing sensor is open or the wire from the safing sensor to the diagnosis (control) unit (terminal No. 3) is shorted.	<ol style="list-style-type: none"> 1. Visually check the wiring harness connections. 2. Replace the safing sensor. (safing sensor and tunnel sensor unit) 3. Replace the diagnosis (control) unit. 4. Replace the main harness.
SAFING SENSOR [SHORT/LWR-VB-SHORT]	Both the wires for the safing sensor are shorted or the wire from the safing sensor to the diagnosis (control) unit (terminal No. 3) is shorted to some power supply circuit.	<ol style="list-style-type: none"> 3. Replace the diagnosis (control) unit. 4. Replace the main harness.
AIRBAG MODULE [OPEN]	The circuit for driver's air bag module is open. (including the spiral cable)	<ol style="list-style-type: none"> 1. Visually check the wiring harness connections. 2. Replace the spiral cable. 3. Replace driver's air bag module. (Before disposing of it, it must be deployed.) 4. Replace the diagnosis (control) unit. 5. Replace the main harness.
AIRBAG MODULE [VB-SHORT]	The circuit for driver's air bag module is shorted to some power supply circuit. (including the spiral cable)	<ol style="list-style-type: none"> 3. Replace driver's air bag module. (Before disposing of it, it must be deployed.) 4. Replace the diagnosis (control) unit. 5. Replace the main harness.
AIRBAG MODULE [GND-SHORT]	The circuit for driver's air bag module is shorted to ground. (including the spiral cable)	<ol style="list-style-type: none"> 4. Replace the diagnosis (control) unit. 5. Replace the main harness.
AIRBAG MODULE [SHORT]	The circuits for driver's air bag module are shorted to each other.	
TUNNEL SENSOR [OPEN/UPR-VB-SHORT]	The circuit for the tunnel sensor is open or the wire from the diagnosis (control) unit (terminal No. 6) to the tunnel sensor is shorted to some power supply circuit.	<ol style="list-style-type: none"> 1. Visually check the wiring harness connections. 2. Replace the tunnel sensor. (safing sensor and tunnel sensor unit) 3. Replace the diagnosis (control) unit. 4. Replace the main harness.
TUNNEL SENSOR [SHORT/UPR-GND-SHORT]	Both the wires for the tunnel sensor are shorted or the wire from the diagnosis (control) unit (terminal No. 6) to the tunnel sensor is shorted to ground.	<ol style="list-style-type: none"> 3. Replace the diagnosis (control) unit. 4. Replace the main harness.
CRASH ZONE SEN-CTR [OPEN/UPR-VB-SHORT]	The circuit for the crash zone sensor is open or the wire from the diagnosis (control) unit (terminal No. 9) to the crash zone sensor is shorted to some power supply circuit.	<ol style="list-style-type: none"> 1. Visually check the wiring harness connections. 2. Replace the crash zone sensor. 3. Replace the diagnosis (control) unit. 4. Replace the main harness.
CRASH ZONE SEN-CTR [SHORT/UPR-GND-SHORT]	Both the wires for the crash zone sensor are shorted or the wire from the diagnosis (control) unit (terminal No. 9) to the crash zone sensor is shorted to ground.	<ol style="list-style-type: none"> 3. Replace the diagnosis (control) unit. 4. Replace the main harness.
DIAGNOSIS (CONTROL) UNIT	The diagnosis unit (control unit) is out of order.	<ol style="list-style-type: none"> 1. Visually check the wiring harness connections. 2. Replace the diagnosis (control) unit. 3. Replace the main harness.
INDEFINITE FAILURES [AIR BAG]	A problem which cannot be specified occurs because more than two parts are out of order.	<ol style="list-style-type: none"> 1. Visually check the wiring harness connections. 2. Replace the diagnosis (control) unit. 3. Replace all sensors, spiral cable and air bag module. 4. Replace the main harness.

TROUBLE DIAGNOSES — Supplemental Restraint System (SRS)

Self-diagnosis (Cont'd)

USING THE WARNING LAMP

Self-diagnosis results can be also read by using the "AIR BAG" warning lamp.

The "Air bag" warning lamp operates as shown below:

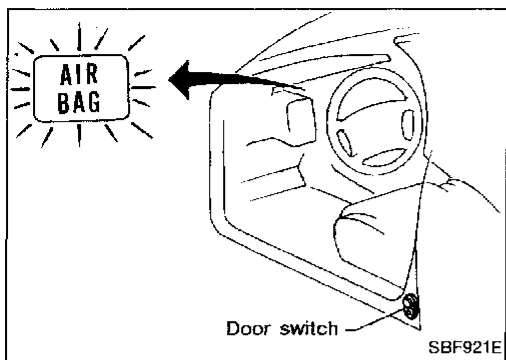

How to alternate self-diagnosis

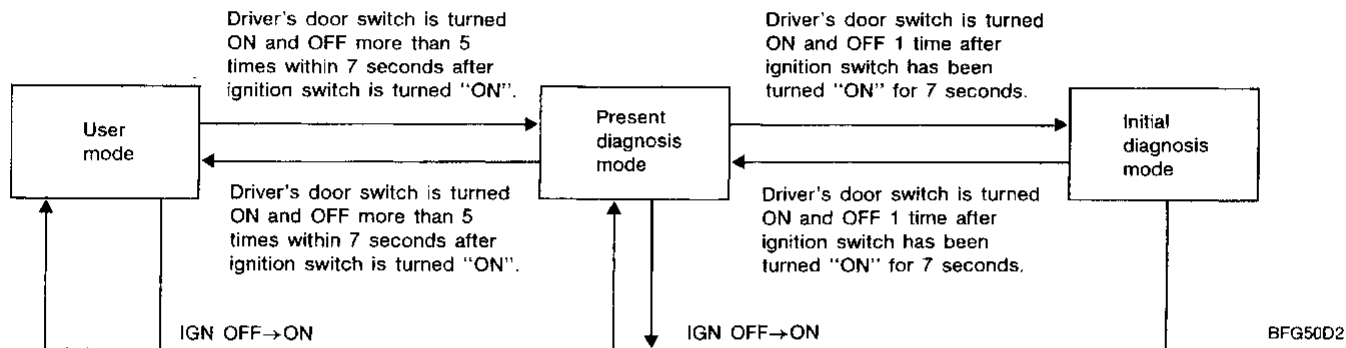

Problem codes are displayed in present diagnosis mode (self-diagnosis result 1). The problem code last indicated is displayed in initial diagnosis mode (self-diagnosis result 2).

After the malfunctioning parts have been repaired and the system is returned to the user mode, the present diagnosis mode information, displayed as self-diagnosis results, is automatically cleared from memory.

- After repairing malfunctioning part, attempt to clear self-diagnosis results from memory.
- If a malfunctioning part is not completely repaired, information stored in memory will not be cleared.

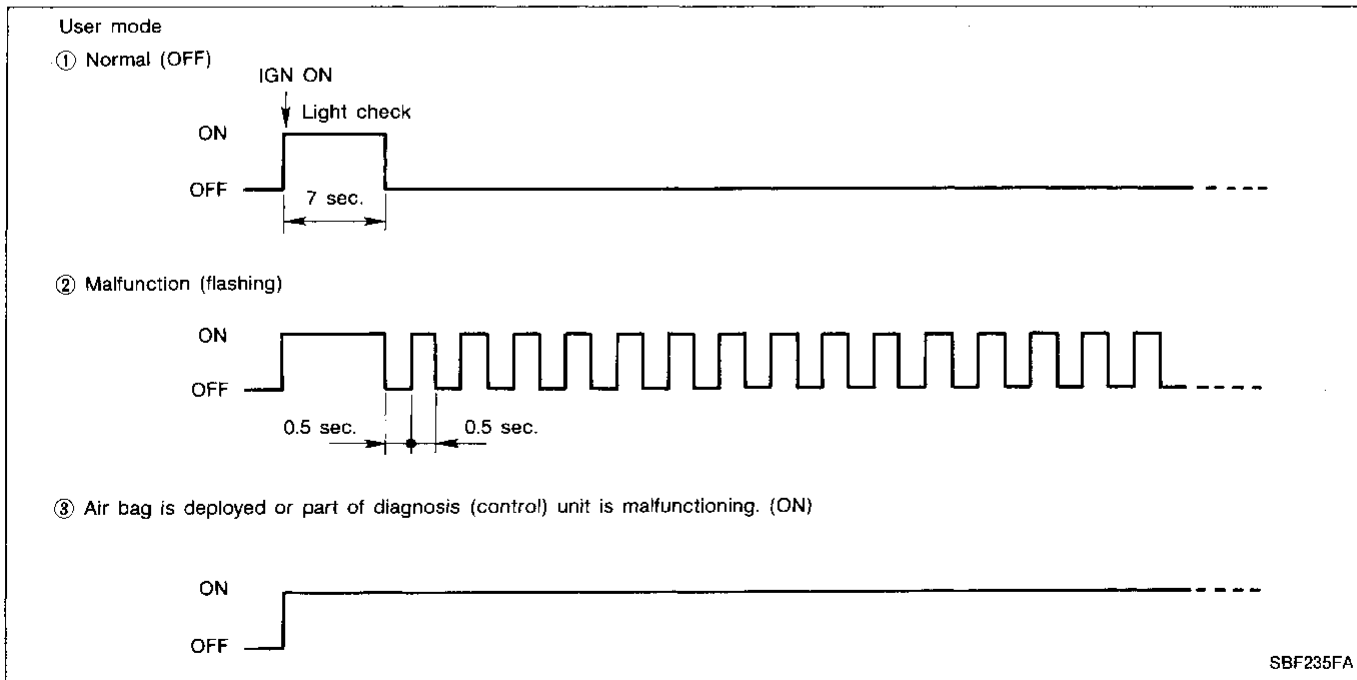

TROUBLE DIAGNOSES — Supplemental Restraint System (SRS)

Self-diagnosis (Cont'd)

Present diagnosis mode (self-diagnosis result 1)

(b) Start signal; Start signal identifies display modes.

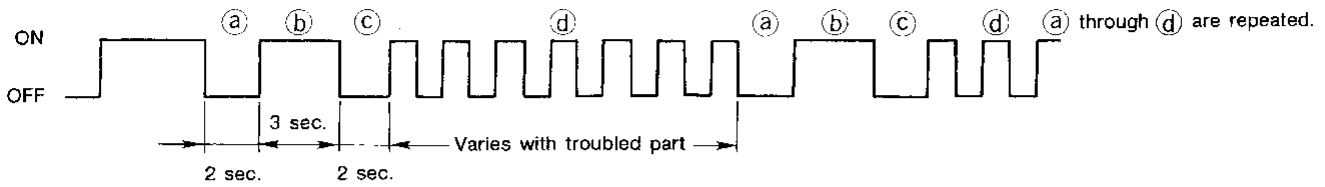

No trouble (or intermittent trouble/repair completion)

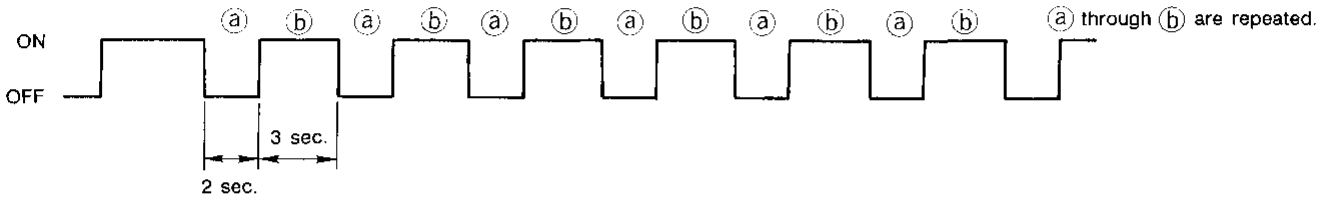

SBF236FA

Initial diagnosis mode (self-diagnosis result 2)

(b) Start signal; Start signal identifies display modes.

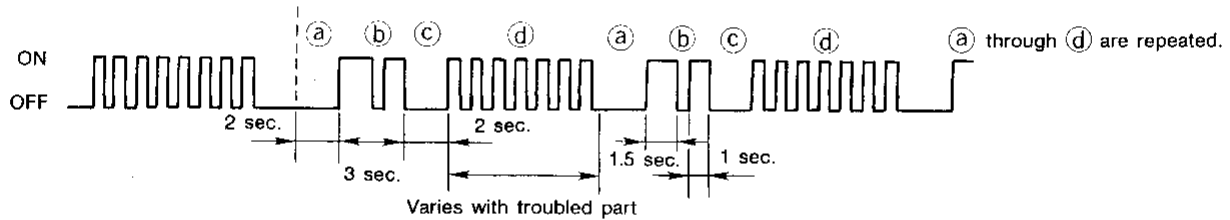

No trouble

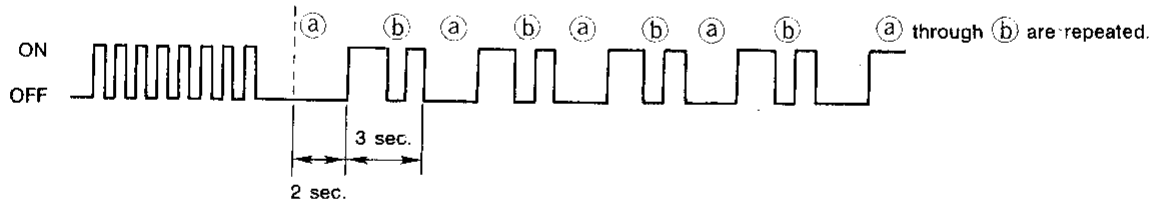

SBF237FA

Self-diagnosis results in present- and initial-diagnosis modes can be identified by number of flashes (d). Refer to Table on next page for troubled parts.

TROUBLE DIAGNOSES — Supplemental Restraint System (SRS)

Self-diagnosis (Cont'd)

Warning lamp flashing times and repair

Warning lamp	Flash code ① (# of flashes)	Explanation	Repair order * Recheck SRS at each replacement.	
"AIR BAG" warning lamp	0	Normal. The SRS "Air Bag" is in good order.	—	GI
	1	The circuit for the safing sensor is out of order.	1. Visually check the wiring harness connections. 2. Replace the safing sensor. (safing sensor and tunnel sensor unit) 3. Replace the diagnosis (control) unit. 4. Replace the main harness.	MA EM
	2	The circuit for the air bag module is out of order.	1. Visually check the wiring harness connections. 2. Replace the spiral cable. 3. Replace the air bag module. (Before disposing of it, it must be deployed.) 4. Replace the diagnosis (control) unit. 5. Replace the main harness.	LC EF & EC
	3	The circuit for the tunnel sensor is out of order.	1. Visually check the wiring harness connections. 2. Replace the tunnel sensor. (safing sensor and tunnel sensor unit) 3. Replace the diagnosis (control) unit. 4. Replace the main harness.	FE CL
	6	The circuit for the front crash zone sensor is out of order.	1. Visually check the wiring harness connections. 2. Replace the front crash zone sensor. 3. Replace the diagnosis (control) unit. 4. Replace the main harness.	WT
	7	The diagnosis unit (control unit) is out of order.	1. Visually check the wiring harness connections. 2. Replace the diagnosis (control) unit. 3. Replace the main harness.	AT FA
	8	More than two parts groups are out of order.	1. Visually check the wiring harness connections. 2. Replace the diagnosis (control) unit. 3. Replace all sensors, spiral cable and air bag module. 4. Replace the main harness.	RA

BR

ST

BF

HA

EL

IDX

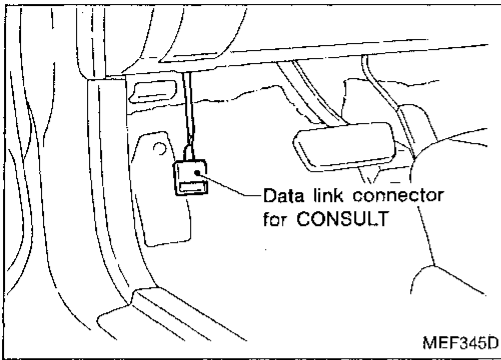

Diagnostic Procedure 1

SYMPTOM: Warning lamp flashes.

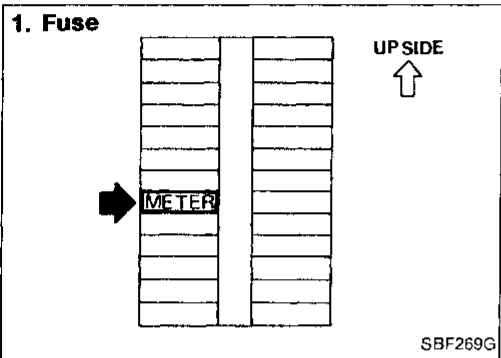
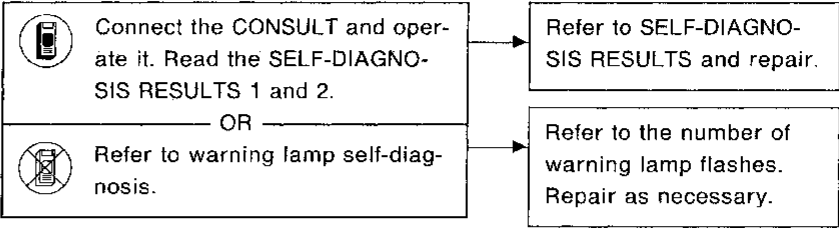

Diagnostic Procedure 2

SYMPTOM: Warning lamp does not come on.

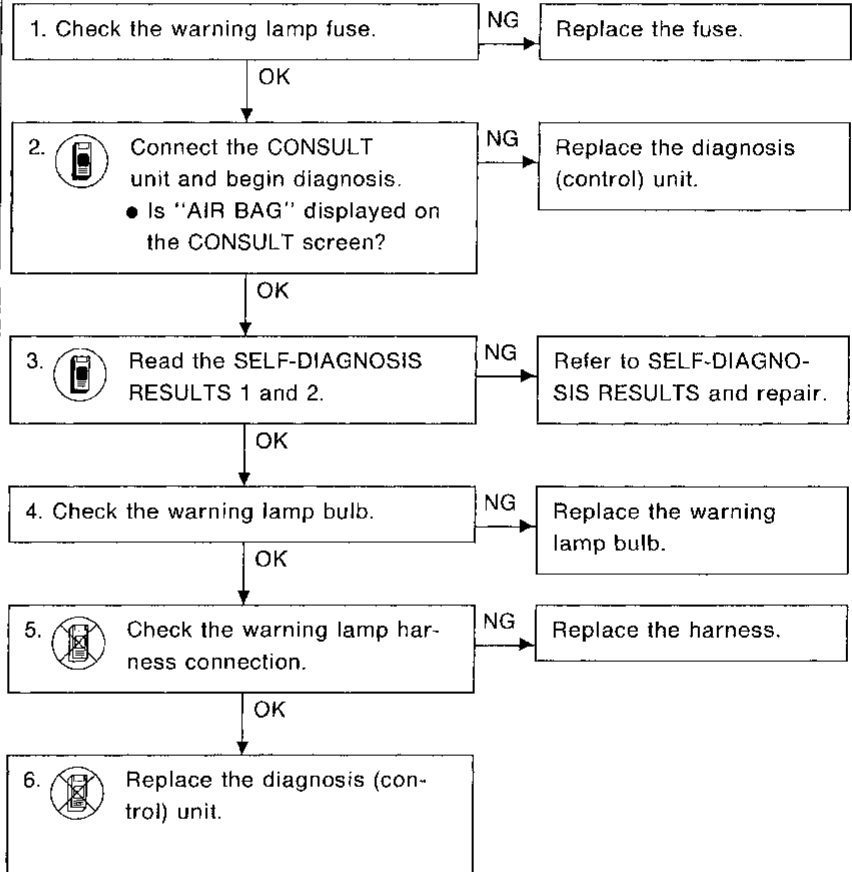
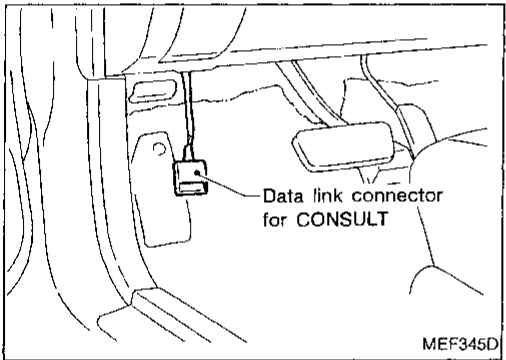

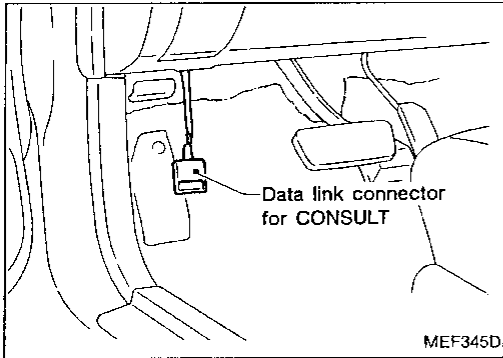
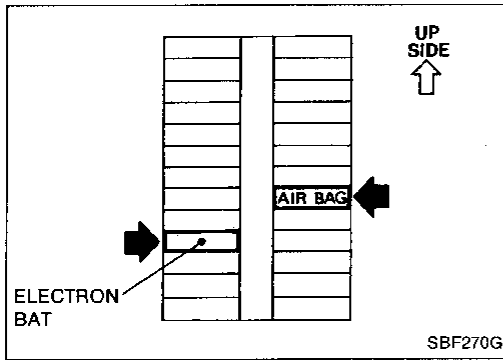

Diagnostic Procedure 3

SYMPTOM: Warning lamp does not go off.

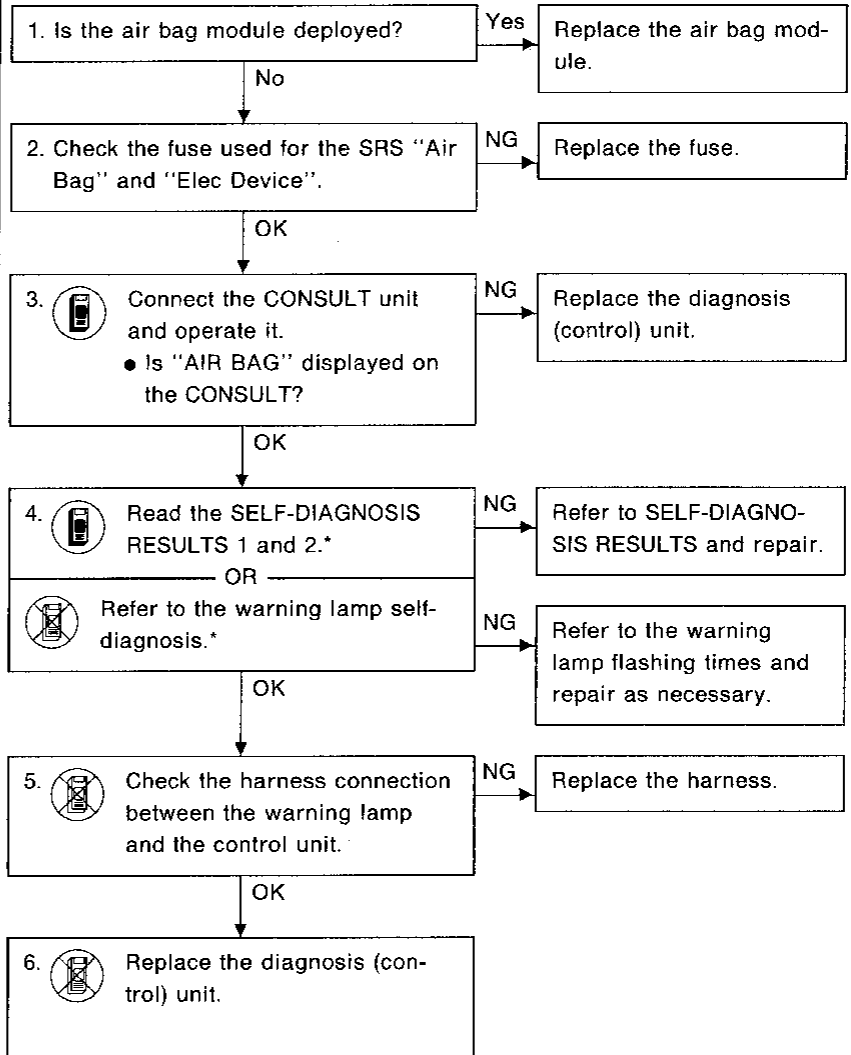

* Recheck SRS after each replacement.

GI

MA

EM

LC

EF &
EC

FE

CL

MT

AT

FA

RA

BR

ST

BF

HA

EL

IDX

Collision Diagnosis

To repair the SRS "AIR BAG", perform the following steps.

When air bag deployed in a collision:

- ① Replace the diagnosis (control) unit.
- ② Remove the air bag module.
- ③ Check the SRS components using the table shown below:
 - If the SRS components are showing any visible damage such as dents, cracks, or deformation, replace them with new ones.
- ④ Conduct self-diagnosis using CONSULT or "AIR BAG" warning lamp to ensure entire SRS operates properly except open circuits of air bag module.
- ⑤ Install new air bag module.
- ⑥ Conduct self-diagnosis again.

When air bag did not deploy in a collision:

- ① Check the SRS components using the table shown below:
 - If the SRS components are showing any visible damage such as dents, cracks, or deformation, replace them with new ones.
- ② Conduct self-diagnosis using CONSULT or "AIR BAG" warning lamp to ensure entire SRS operates properly.

SRS inspection

Part	Air bag deployed	Air bag did NOT deploy
Air bag module	REPLACE Install with new bolts.	<ol style="list-style-type: none"> 1. Remove air bag module. Check harness cover and connectors for damage, terminals for deformities, and harness for binding. 2. Install air bag module into the steering wheel to check fit and alignment with the wheel. 3. No damage found, reinstall with new bolts. 4. If damaged—REPLACE. Air bag must be deployed before discarding.
Diagnosis (Control) unit	REPLACE Install with new bolts.	<ol style="list-style-type: none"> 1. Check case and bracket for dents, cracks or deformities. 2. Check connectors for damage, and terminals for deformities. 3. If no damage is found, reinstall with new bolts. 4. If damaged—REPLACE.
Sensors		<ol style="list-style-type: none"> 1. Check body and sensor brackets for deformities or rust. 2. Check sensor case for dents, cracks, scratches, deformities or rust. 3. Check sensor harness, connector, and terminals for binding, damage, or deformities. 4. If no damage is found, reinstall with new bolts. 5. If damaged—REPLACE.
Steering wheel		<ol style="list-style-type: none"> 1. Check harness (built into steering wheel) and connectors for damage, and terminals for deformities. 2. Install air bag module to check fit or alignment with steering wheel. 3. Check steering wheel for excessive free play. 4. If no damage is found, reinstall with new bolts. 5. If damaged—REPLACE.
Spiral cable		<ol style="list-style-type: none"> 1. Visually check lock (engagement) pins and combination switch for damage. 2. Check connectors, flat cable and protective tape for damage. 3. Check steering wheel for noise, binding or heavy operation. 4. If no damage is found, reinstall with new bolts. 5. If damaged—REPLACE.
Harness and Connectors		<ol style="list-style-type: none"> 1. Check connectors for poor connection, damage, and terminals for deformities. 2. Check harness for binding, chafing, cuts, or deformities. 3. If no damage is found, reinstall 4. Damaged—REPLACE damaged section of harness. Do not attempt to repair, splice or modify any SRS harness.