

# BODY AND TRIM

## SECTION **BT**

### CONTENTS

<b>PRECAUTIONS</b> .....	2	Roof Trim .....	19
Service Notice.....	2	Trunk Room Trim .....	20
Supplemental Restraint System (SRS) "AIR BAG" and "SEAT BELT PRE-TENSIONER".....	2	<b>EXTERIOR</b> .....	21
<b>GENERAL SERVICING</b> .....	3	<b>SEAT</b> .....	27
Clip and Fastener .....	3	Front Seat .....	28
<b>BODY END</b> .....	5	Heated Seat.....	29
Body Front End.....	5	Rear Seat.....	30
Body Rear End and Opener.....	8	<b>SUNROOF</b> .....	31
<b>DOOR</b> .....	11	Trouble Diagnoses.....	35
Front Door.....	11	<b>WINDSHIELD AND WINDOWS</b> .....	39
Rear Door .....	12	Windshield and Rear Window .....	40
<b>INSTRUMENT PANEL</b> .....	13	<b>MIRROR</b> .....	41
<b>INTERIOR TRIM</b> .....	16	Door Mirror.....	41
Side and Floor Trim .....	16	<b>BODY ALIGNMENT</b> .....	42
Door Trim .....	18	Engine Compartment.....	42
		Underbody .....	44

- ★ For seat belt, refer to MA and RS section.
- ★ For wiring diagrams of body electrical systems, refer to EL section.

GI  
MA  
EM  
LC  
EC  
FE  
CL  
MT  
AT  
FA  
RA  
BR  
ST  
RS  
**BT**  
HA  
EL  
IDX

# PRECAUTIONS

---

## Service Notice

- When removing or installing various parts, place a cloth or padding onto the vehicle body to prevent scratches.
- Handle trim, molding, instruments, grille, etc. carefully during removing or installing. Be careful not to soil or damage them.
- Apply sealing compound where necessary when installing parts.
- When applying sealing compound, be careful that the sealing compound does not protrude from parts.
- When replacing any metal parts (for example body outer panel, members, etc.), be sure to take rust prevention measures.

## Supplemental Restraint System (SRS) “AIR BAG” and “SEAT BELT PRE-TENSIONER”

The Supplemental Restraint System “AIR BAG” and “SEAT BELT PRE-TENSIONER”, used along with a seat belt, help to reduce the risk or severity of injury to the driver and front passenger in a frontal collision. The Supplemental Restraint System consists of air bag modules (located in the center of the steering wheel and on the instrument panel on the passenger side), seat belt pre-tensioners, a diagnosis sensor unit, warning lamp, wiring harness and spiral cable.

In addition to the supplemental air bag modules for a frontal collision, the supplemental side air bag used along with the seat belt helps to reduce the risk or severity of injury to the driver and front passenger in a side collision. The supplemental side air bag consists of air bag modules (located in the outer side of front seats), satellite sensor, diagnosis sensor unit (which is one of components of supplemental air bags for a frontal collision), wiring harness, warning lamp (which is one of components of supplemental air bags for a frontal collision). Information necessary to service the system safely is included in the **RS section** of this Service Manual.







### WARNING:

- **To avoid rendering the SRS inoperative, which could increase the risk of personal injury or death in the event of a collision which would result in air bag inflation, all maintenance must be performed by an authorized INFINITI dealer.**
- **Improper maintenance, including incorrect removal and installation of the SRS, can lead to personal injury caused by unintentional activation of the system.**
- **Do not use electrical test equipment on any circuit related to the SRS unless instructed to in this Service Manual. SRS wiring harnesses (except “SEAT BELT PRE-TENSIONER” connector) can be identified with yellow harness connector (and with yellow harness protector or yellow insulation tape before the harness connectors).**

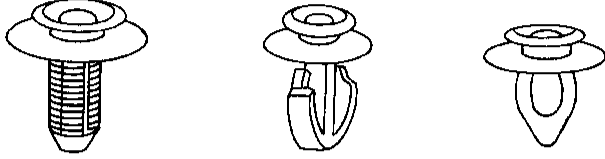
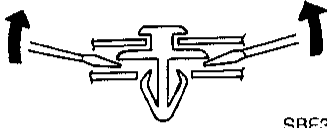
# GENERAL SERVICING

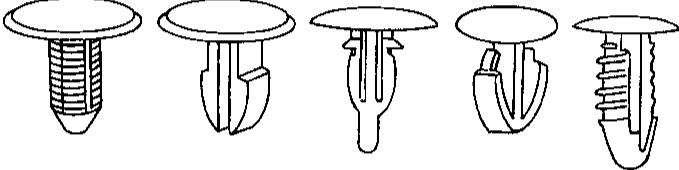
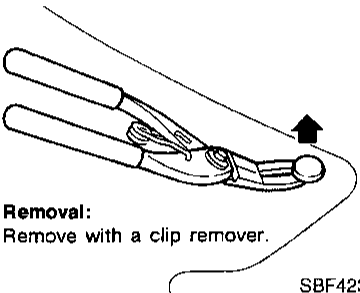
## Clip and Fastener

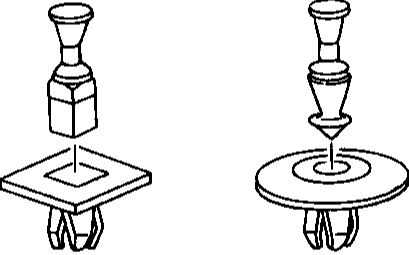
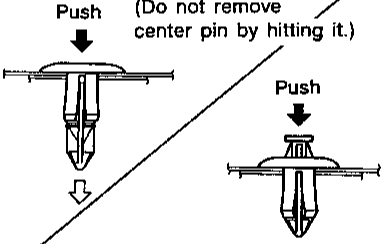
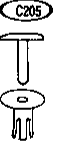
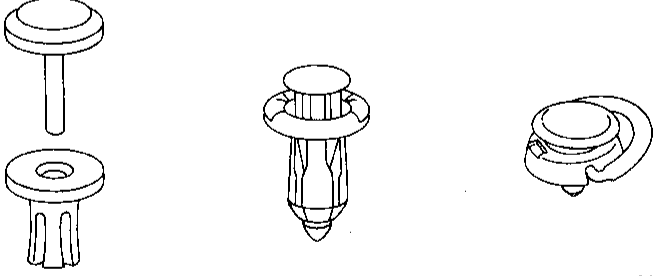
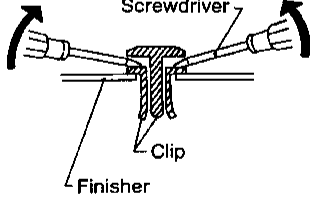

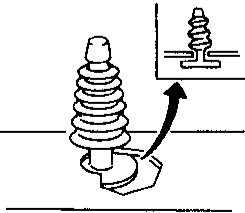
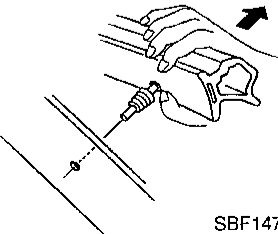



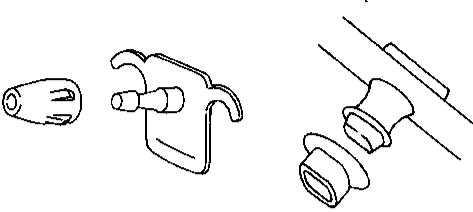
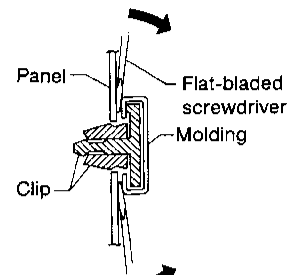

- Clips and fasteners in BT section correspond to the following numbers and symbols.
- Replace any clips and/or fasteners which are damaged during removal or installation.

Symbol No.	Shapes	Removal & Installation
	 <p style="text-align: right;">SBF302H</p>	<p><b>Removal:</b> Remove by bending up with flat-bladed screwdrivers or clip remover.</p>  <p style="text-align: right;">SBF367BA</p>
	 <p style="text-align: right;">SBF303H</p>	<p><b>Removal:</b> Remove with a clip remover.</p>  <p style="text-align: right;">SBF423H</p>
	 <p style="text-align: right;">SBF258G</p>	<p>Push center pin to catching position. (Do not remove center pin by hitting it.)</p> <p>Push</p>  <p><b>Installation:</b></p> <p style="text-align: right;">SBF708E</p>
	 <p style="text-align: right;">MBT080A</p>	<p><b>Removal:</b></p>  <p style="text-align: right;">SBF638C</p>
	 <p style="text-align: right;">SBF104B</p>	<p><b>Removal:</b></p>  <p style="text-align: right;">SBF147B</p>

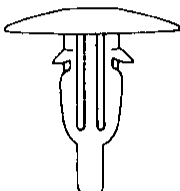
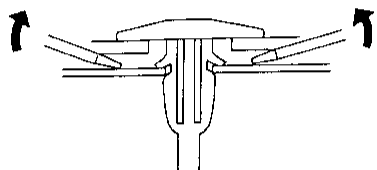
GI  
 MA  
 EM  
 LC  
 EC  
 FE  
 CL  
 MT  
 AT  
 FA  
 RA  
 BR  
 ST  
 RS  
**BT**  
 HA  
 EL  
 IDX

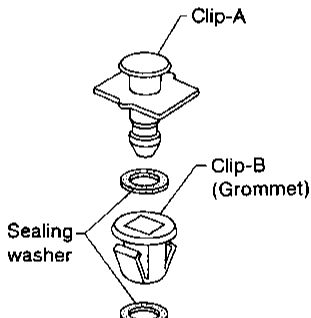
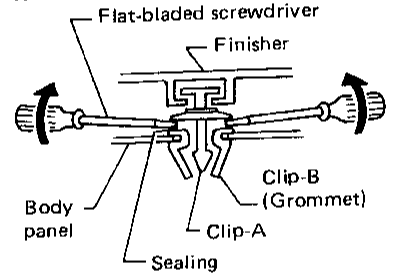
# GENERAL SERVICING

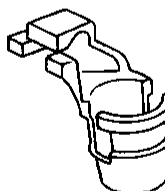
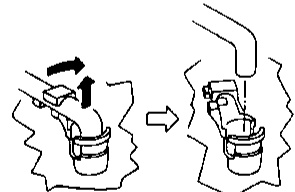
## Clip and Fastener (Cont'd)

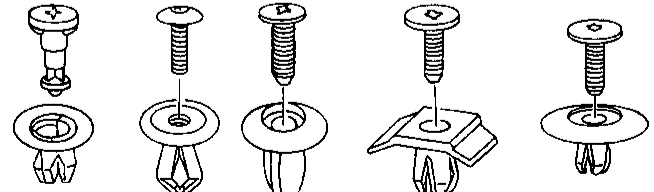
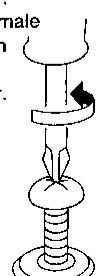
Symbol No.	Shapes	Removal & Installation
		 <p style="text-align: right;">SBF767B</p>
		<p><b>Removal:</b> Remove with a flat-bladed screwdriver or pliers.</p>  <p style="text-align: right;">SBF175D</p>
		<p><b>Removal:</b></p>  <p style="text-align: right;">SBF259G</p>
		<p><b>Removal:</b> Holder portion of clip must be spread out to remove rod.</p>  <p style="text-align: right;">SBF770B</p>
		<p><b>Removal:</b></p> <ol style="list-style-type: none"> <li>1. Screw out with a Phillips screwdriver.</li> <li>2. Remove female portion with flat-bladed screwdriver.</li> </ol>  <p style="text-align: right;">SBF992G</p>

## Body Front End

- When removing or installing hood, place a cloth or other padding on front fender panels and cowl top. This prevents vehicle body from being scratched.
- Bumper fascia is made of plastic. Do not use excessive force and be sure to keep oil away from it.
- Hood adjustment: Adjust at hinge portion.
- Hood lock adjustment: After adjusting, check hood lock control operation. Apply a coat of grease to hood locks engaging mechanism.
- Hood opener: Do not attempt to bend cable forcibly. Doing so increases effort required to unlock hood.

### WARNING:

- Be careful not to scratch hood stay when installing hood. A scratched stay may cause gas leakage.
- The contents of the hood stay are under pressure. Do not take apart, puncture, apply heat or allow fire near it.

### REMOVAL — Front bumper assembly

- ① Remove bolts, screws and clips securing left and right sides of front fender protector. **B**
- ② Remove bolts securing bumper fascia to engine undercover. **C**
- ③ Remove screws securing left and right turn signal lamps and remove the lamps. **D**
- ④ Remove bolts and nuts securing left and right headlamps and remove the lamps. **E**
- ⑤ Remove bolts securing left and right cornering lamps and remove the lamps. **F**
- ⑥ Remove bolts securing bumper retainer to bumper fascia. **C**
- ⑦ Remove bolts and nuts securing front fender to bumper fascia. **G**
- ⑧ Remove bolts securing fog lamp bracket to bumper fascia. **H**
- ⑨ Extract bumper fascia assembly.
- ⑩ Remove bolts and nuts securing retainer and remove the retainer. **J**
- ⑪ Remove nuts securing bumper reinforcement to bumper stay. **K**
- ⑫ Extract bumper reinforcement.
- ⑬ Remove bolts and nuts securing bumper stay and remove the bumper stay. **L**

GI

MA

EM

LC

EC

FE

CL

MT

AT

FA

RA

BR

ST

RS

**BT**

HA

EL

IDX

# BODY END

## Body Front End (Cont'd)

SEC. 260•261•262•620•630•650

### Hood lock adjustment

- Adjust hood so that hood primary lock meshes at a position 1 to 1.5 mm (0.039 to 0.059 in) lower than fender.
- After hood lock adjustment, adjust bumper rubber.
- When securing hood lock, ensure it does not tilt. Striker must be positioned at the center of hood primary lock.
- After adjustment, ensure that hood primary and secondary lock operate properly.

### Hood lock secondary latch hooking length

More than 5.0 mm (0.197 in)

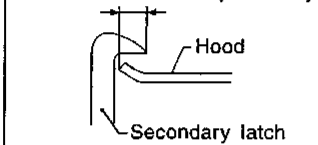

### Bumper rubber adjustment

- Adjust so that hood is aligned with fender. At that time deflection is approx. 2 mm (0.08 in).

[Bumper rubber free height is approx. 13 mm (0.51 in).]

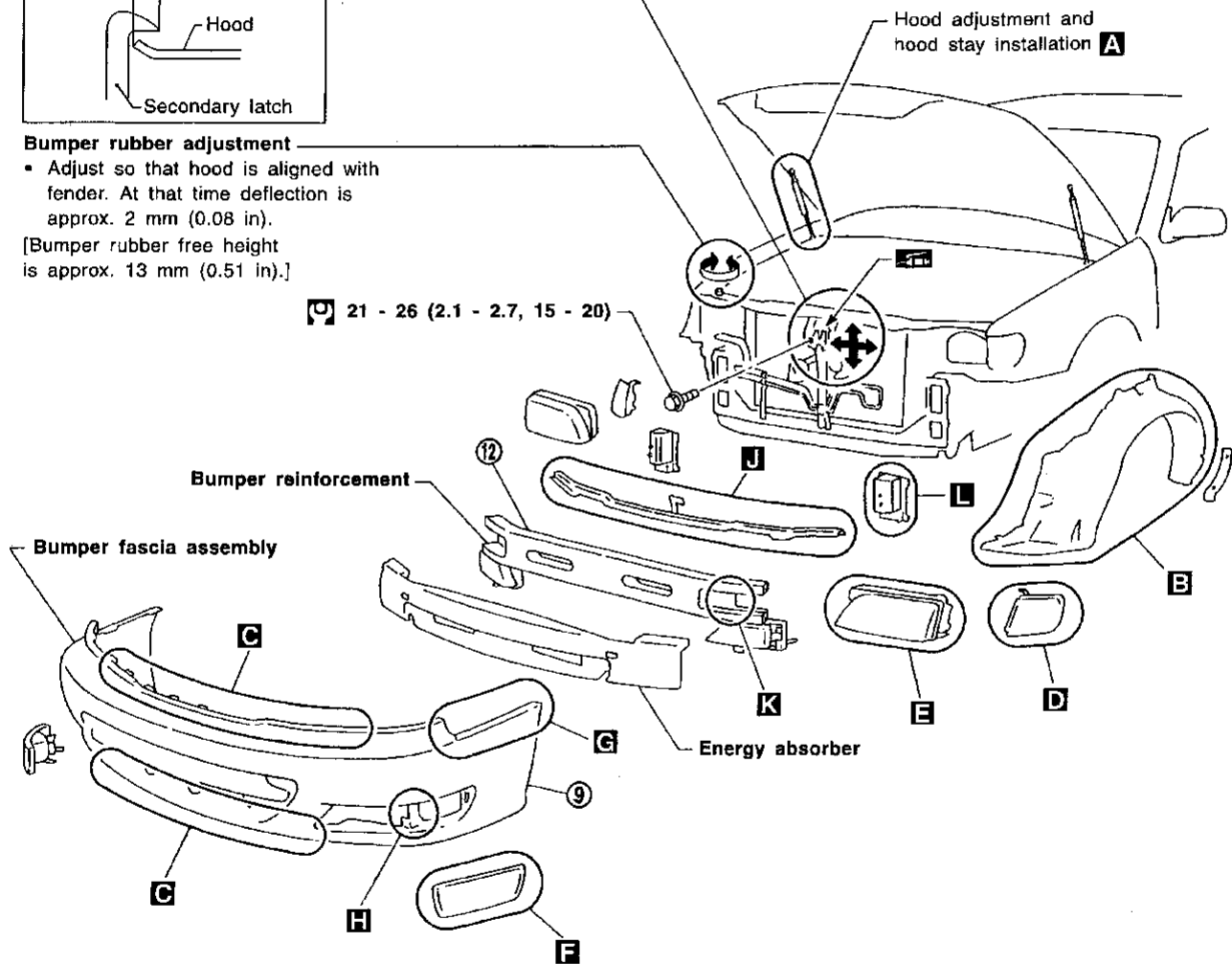

**A** : 16 - 21 (1.6 - 2.1, 12 - 15)

**L** : 25 - 32 (2.6 - 3.3, 19 - 24)

**Ⓞ** : N•m (kg-m, ft-lb)

# BODY END

## Body Front End (Cont'd)

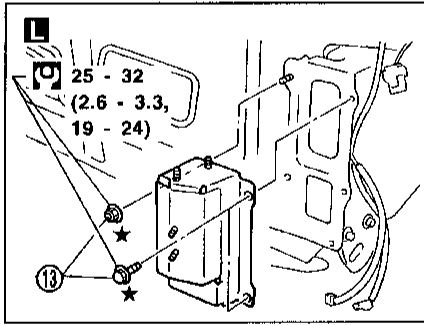
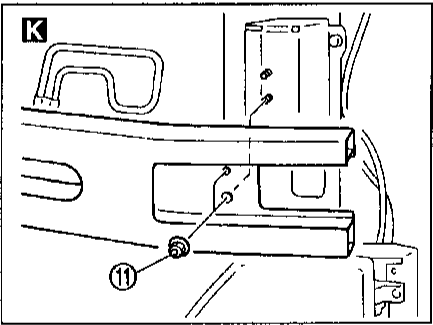
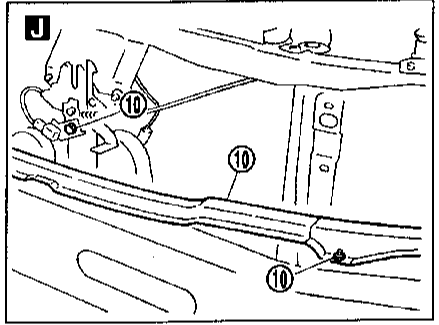
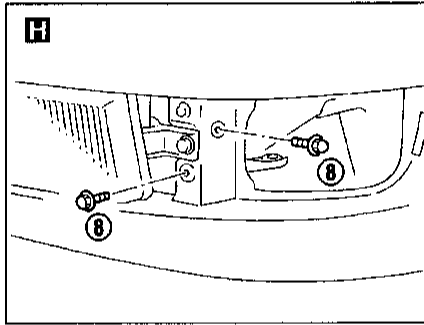
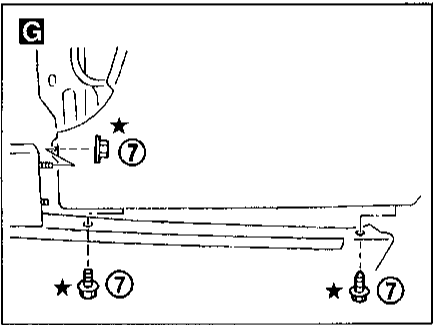
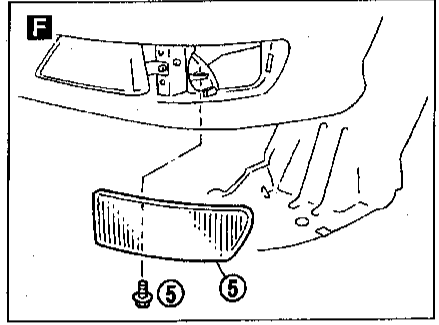
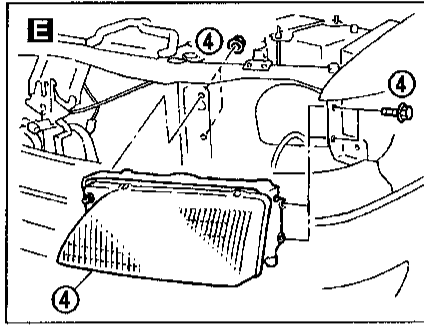
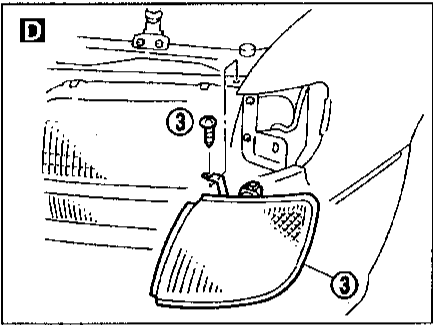
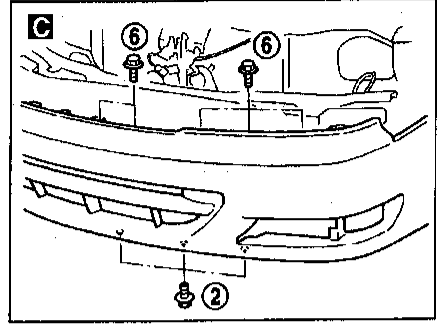
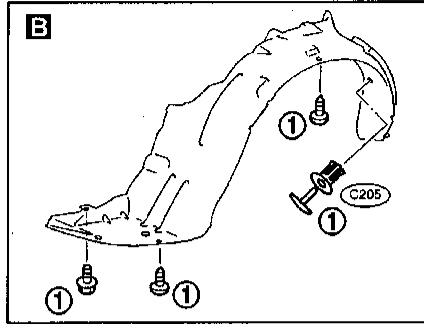
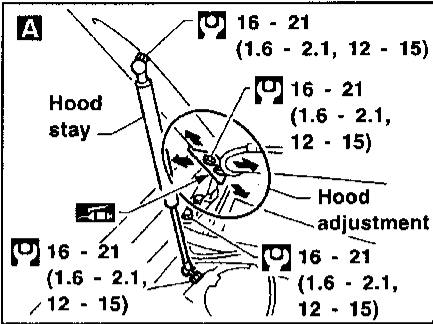

GI  
MA  
EM  
LC  
EC  
FE  
CL  
MT  
AT  
FA  
RA  
BR  
ST  
RS  
BT  
HA  
EL  
IDX

★ : Bumper assembly mounting bolts & nuts  
 [G] : N•m (kg-m, ft-lb)

### Body Rear End and Opener

- When removing or installing trunk lid, place a cloth or other padding on rear fender panels. This prevents vehicle body from being scratched.
- Bumper fascia is made of plastic. Do not use excessive force and be sure to keep oil away from it.
- Trunk lid adjustment: Adjust at hinge-trunk lid portion for proper trunk lid fit.
- Trunk lid lock system adjustment: Adjust striker so that it is in the center of the lock. After adjustment, check trunk lid lock operation.
- After installation, make sure that trunk lid and fuel filler lid open smoothly.
- ★ For Wiring Diagram, refer to "TRUNK LID OPENER" in EL section.

#### REMOVAL — Rear bumper assembly

- ① Remove bolts and clips securing left and right chipping protectors. **A**
- ② Remove bolts securing left and right rear fenders to bumper fascia. **B**
- ③ Remove bolts from lower side of rear bumper fascia. **C**
- ④ Remove trunk room trim. Refer to "Trunk Room Trim" in "INTERIOR TRIM" for details, BT-20.
- ⑤ Working from inside trunk, remove jack and jack bracket. **D**
- ⑥ Working from inside trunk, remove bolts securing left and right rear fenders to bumper fascia. **E**
- ⑦ Working from inside trunk, remove nuts securing left and right rear fenders to bumper fascia. **F**
- ⑧ Remove bumper sight shield assembly. **G**
- ⑨ Remove bolts from upper side of rear bumper fascia. **G**
- ⑩ Extract bumper fascia assembly. Disconnect license lamp harness connector.
- ⑪ Working from inside trunk, remove left and right plugs from floor and then remove bumper reinforcement mounting bolts. **H**
- ⑫ Extract bumper reinforcement.



# BODY END

## Body Rear End and Opener (Cont'd)

SEC. 843-850

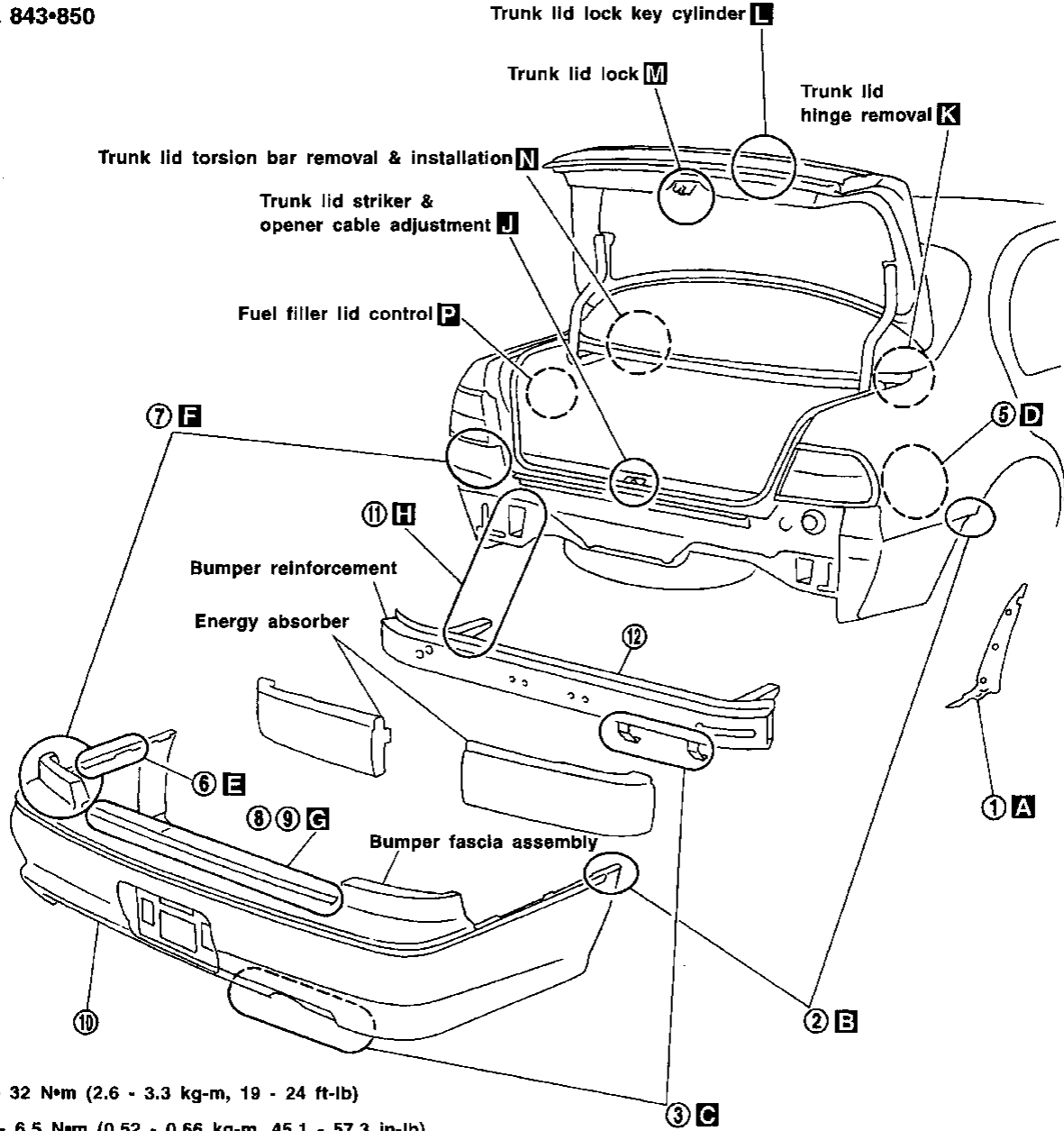

- H** : 25 - 32 N•m (2.6 - 3.3 kg-m, 19 - 24 ft-lb)
- M** : 5.1 - 6.5 N•m (0.52 - 0.66 kg-m, 45.1 - 57.3 in-lb)

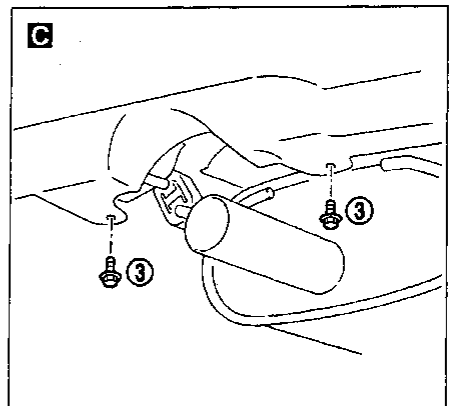
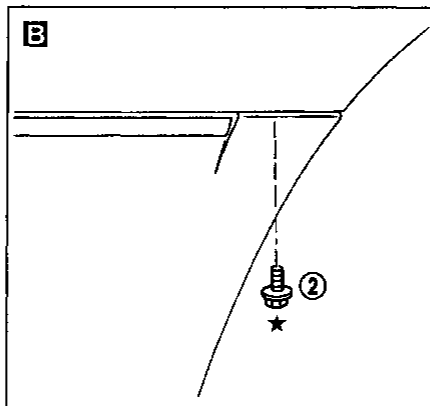
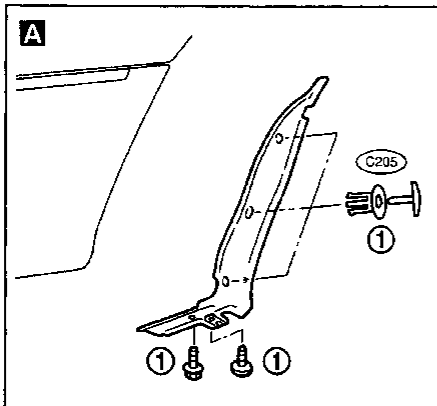

★ : Bumper assembly mounting bolts

GI  
MA  
EM  
LC  
EC  
FE  
CL  
MT  
AT  
FA  
RA  
BR  
ST  
RS  
BT  
HA  
EL  
IDX

# BODY END

## Body Rear End and Opener (Cont'd)

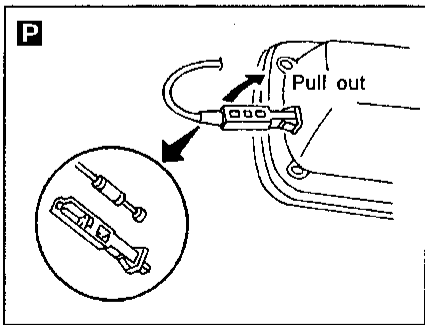
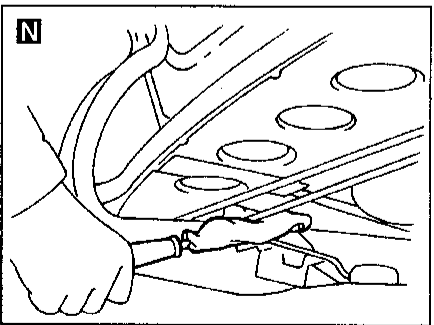
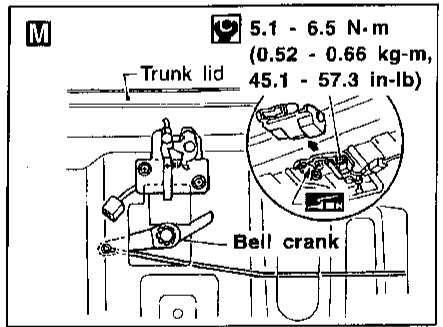
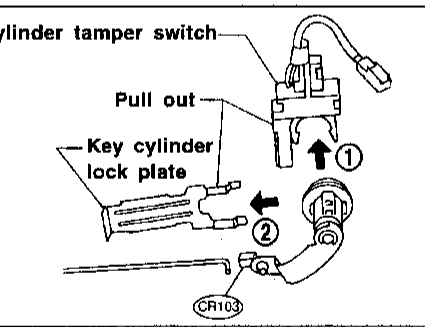
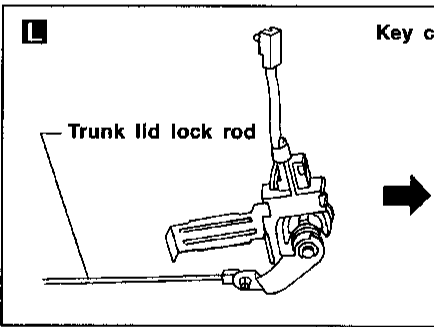
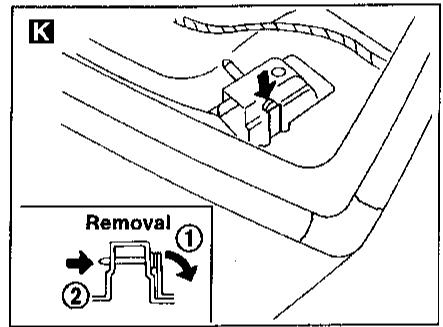
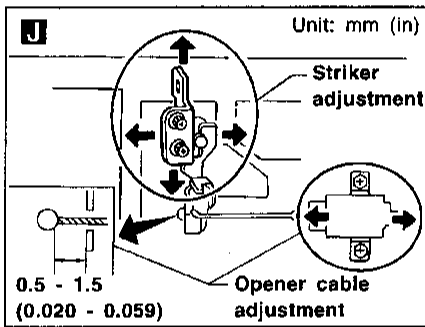
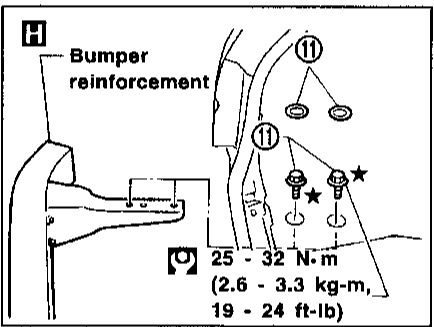
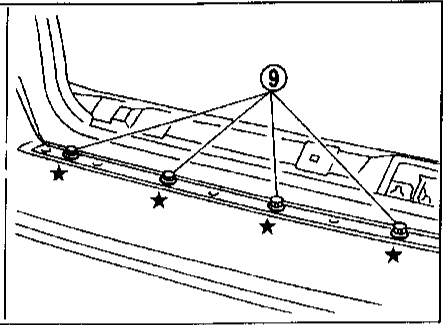
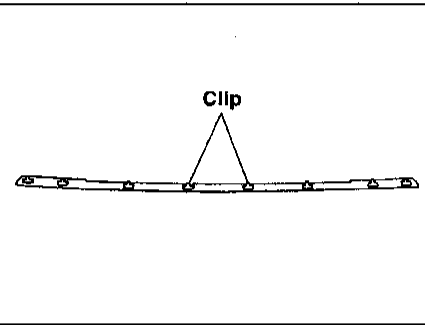
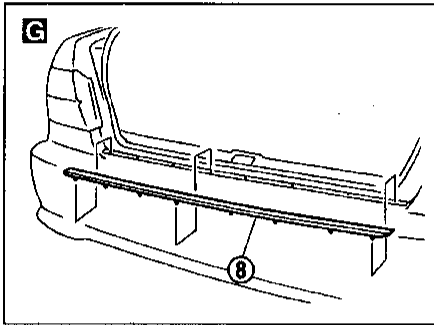
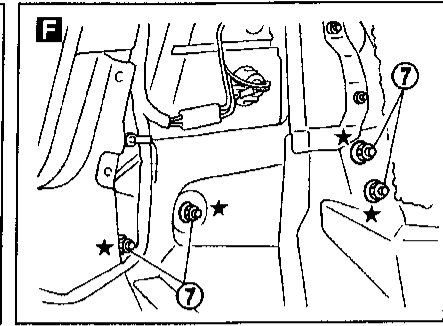
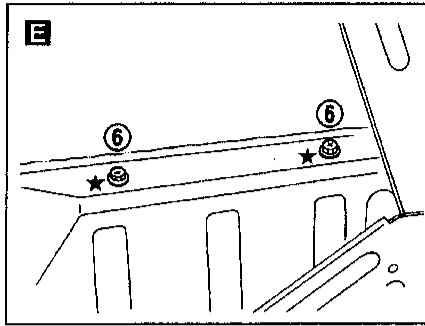
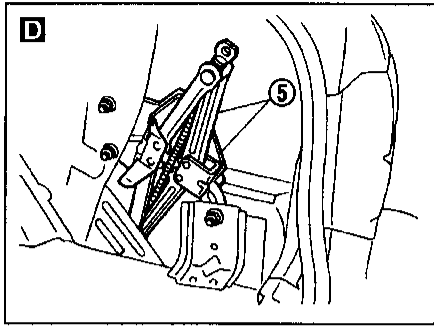

★ : Bumper assembly mounting bolts & nuts

# DOOR

## Front Door

- For removal of door trim, refer to "Door Trim" in "INTERIOR TRIM" (BT-18).
- After adjusting door or door lock, check door lock operation.

SEC. 800•803•805•998

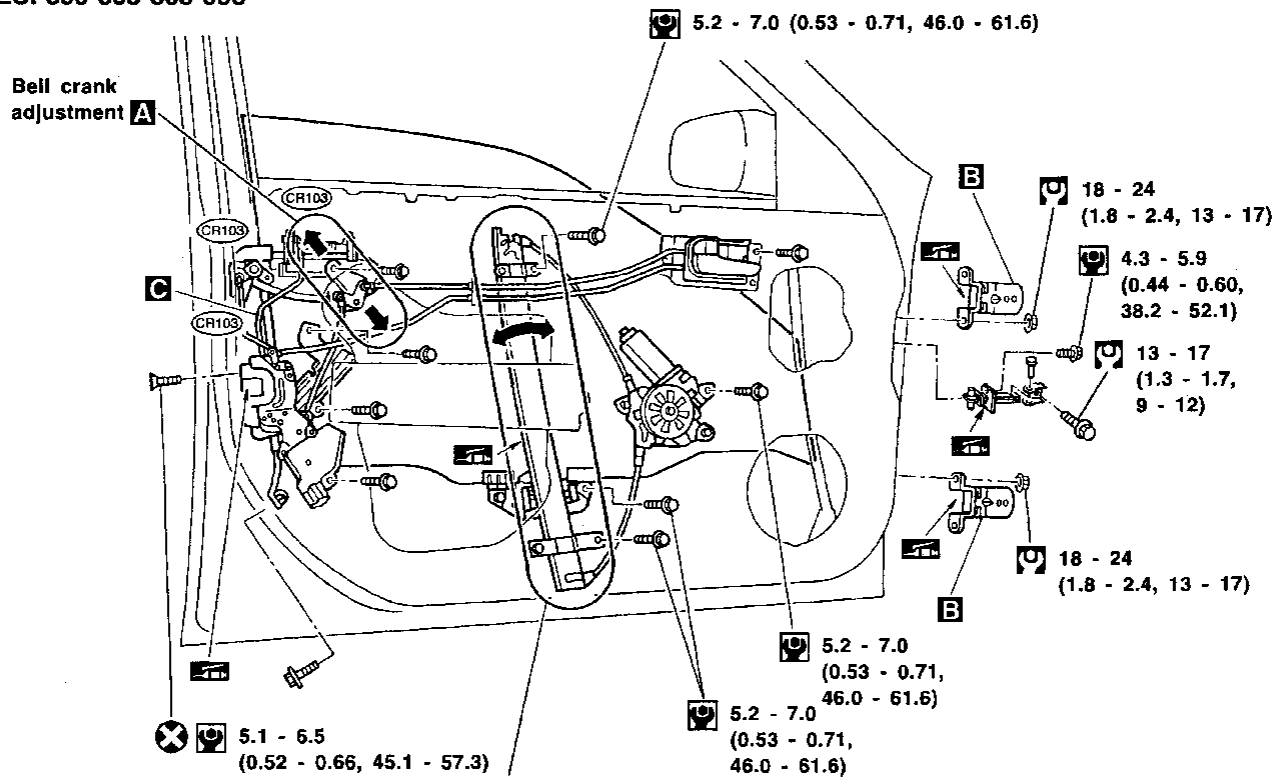

**Door glass adjustment**

- Adjust guide rail mounting position by rotating it.

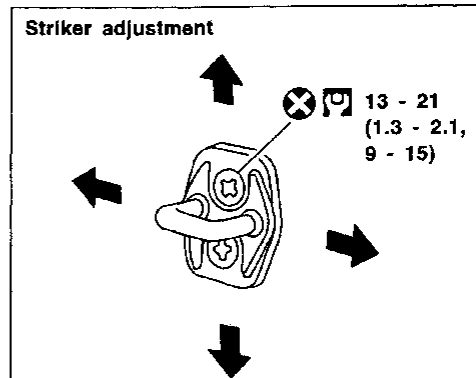
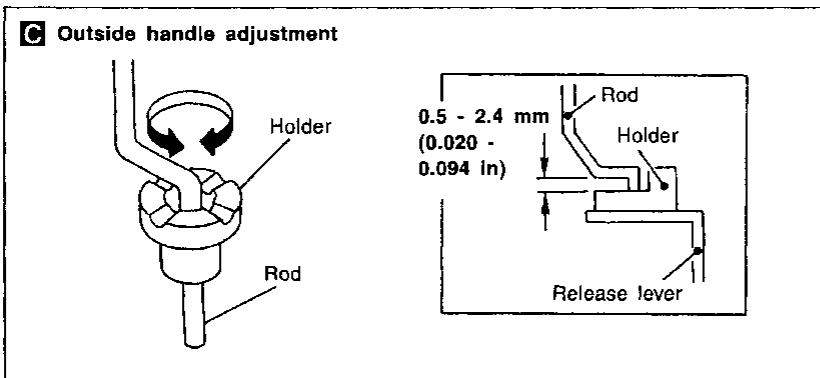
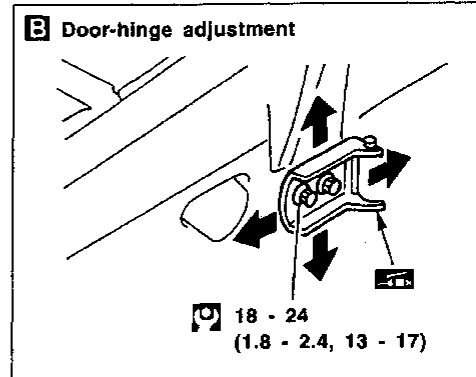
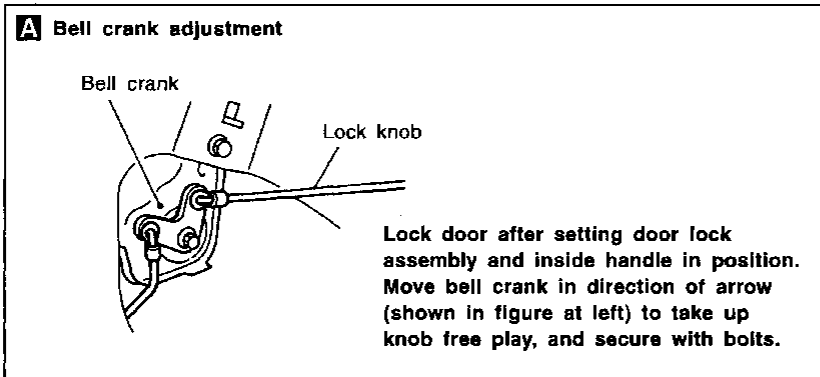

- : N•m (kg-m, in-lb)
- : N•m (kg-m, ft-lb)

SBT479

1293

GI  
MA  
EM  
LC  
EC  
FE  
CL  
MT  
AT  
FA  
RA  
BR  
ST  
RS  
BT  
HA  
EL  
IDX

# DOOR

## Rear Door

SEC. 820•823•825

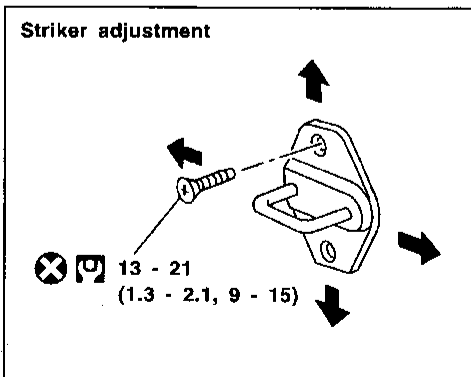
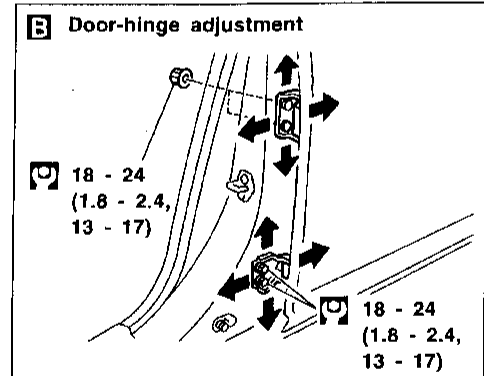
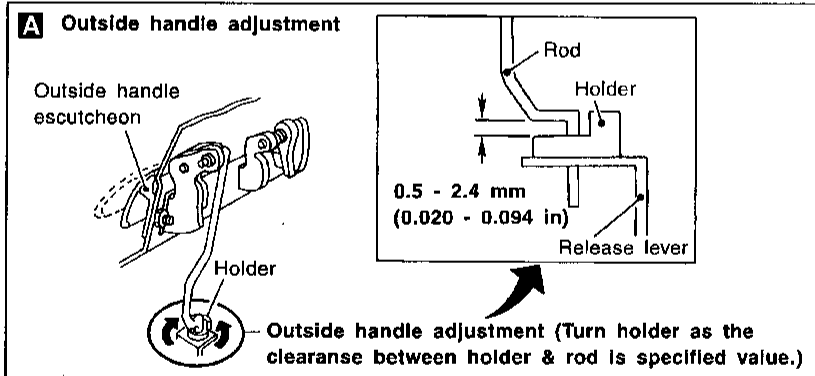
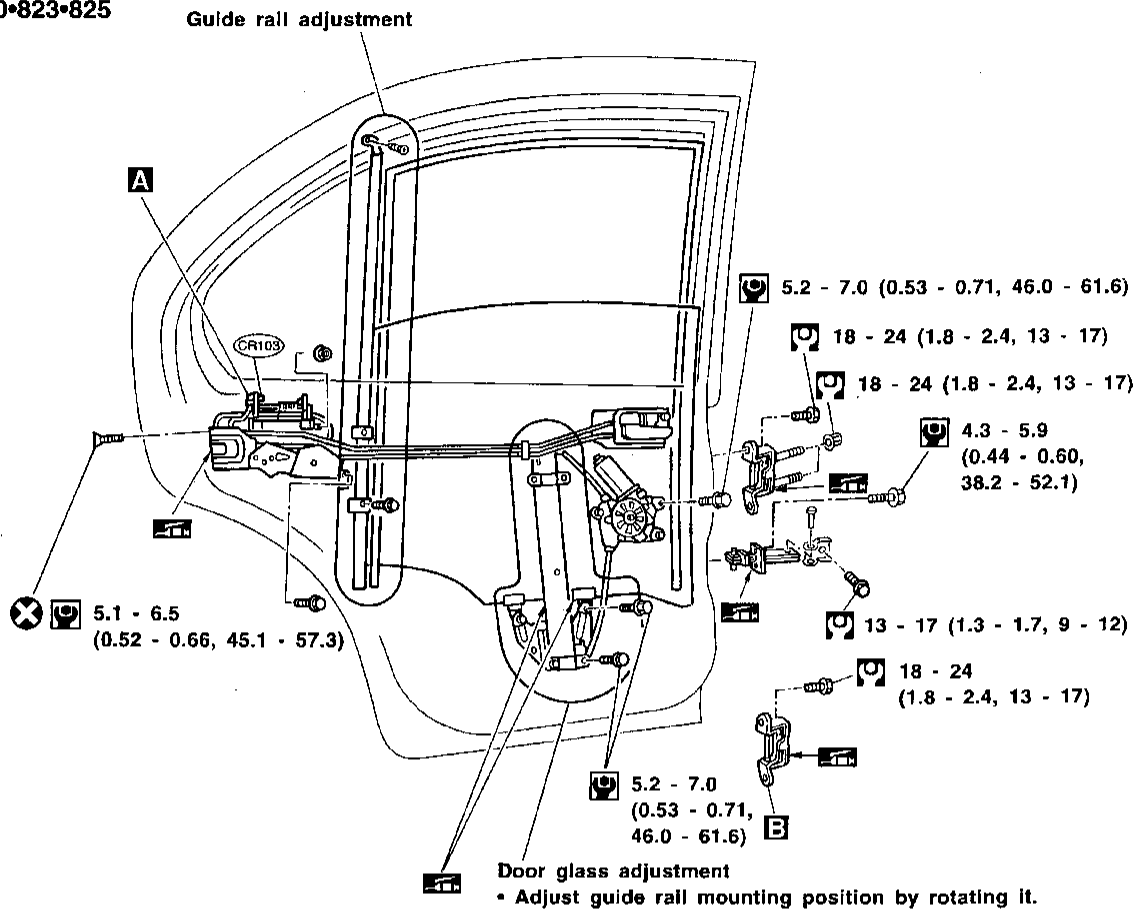

: N•m (kg-m, in-lb)  
 : N•m (kg-m, ft-lb)

# INSTRUMENT PANEL

## CAUTION:

- Disconnect both battery cables in advance.
- Disconnect air bag system line in advance.
- Never tamper with or force air bag lid open, as this may adversely affect air bag performance.
- Be careful not to scratch pad and other parts.

## REMOVAL — Instrument panel assembly

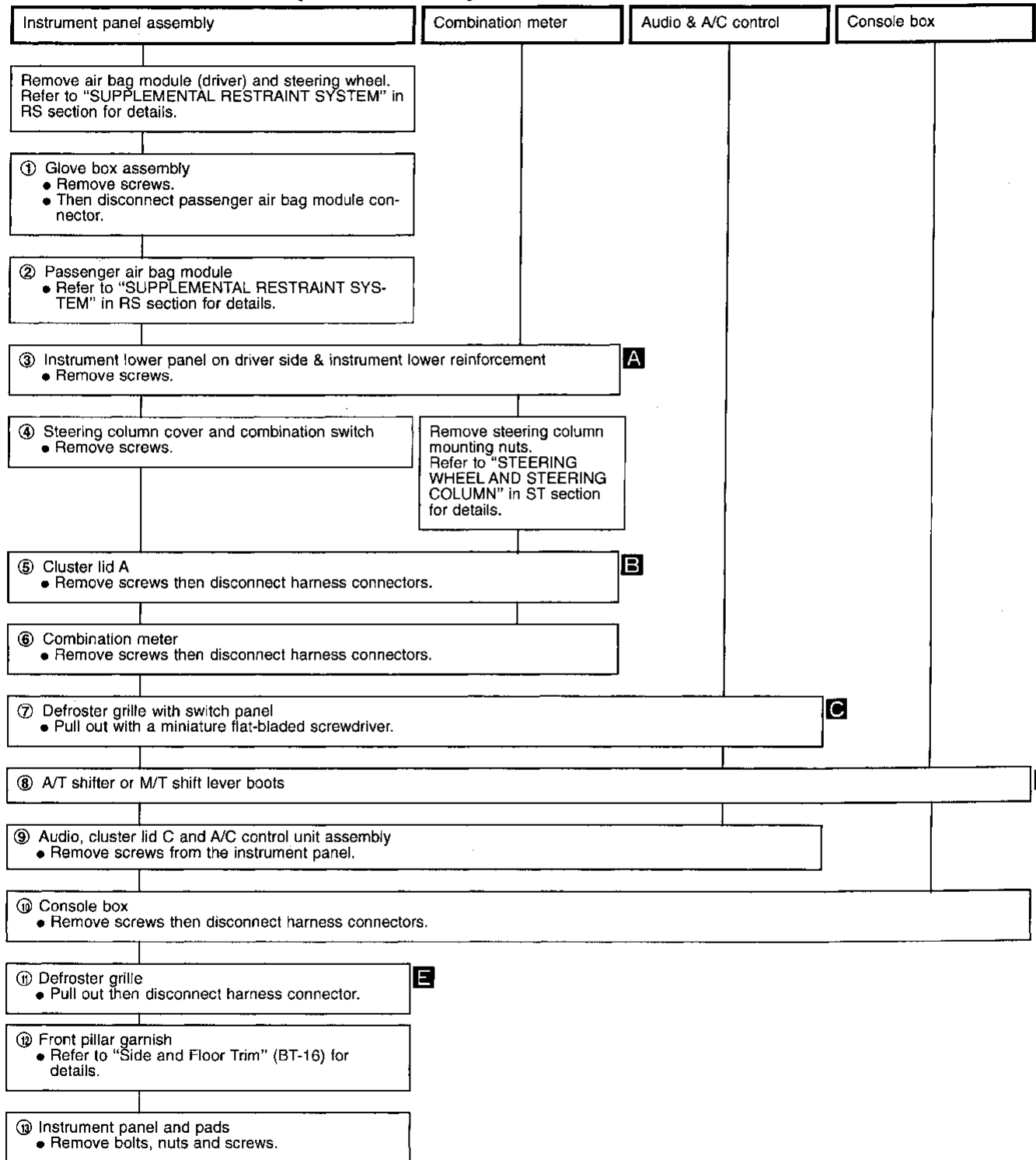

GI  
 MA  
 EM  
 LC  
 EC  
 FE  
 CL  
 MT  
 AT  
 FA  
 RA  
 BR  
 ST  
 RS  
 BT  
 HA  
 EL  
 IDX

# INSTRUMENT PANEL

SEC. 248-280-487-680-685-969

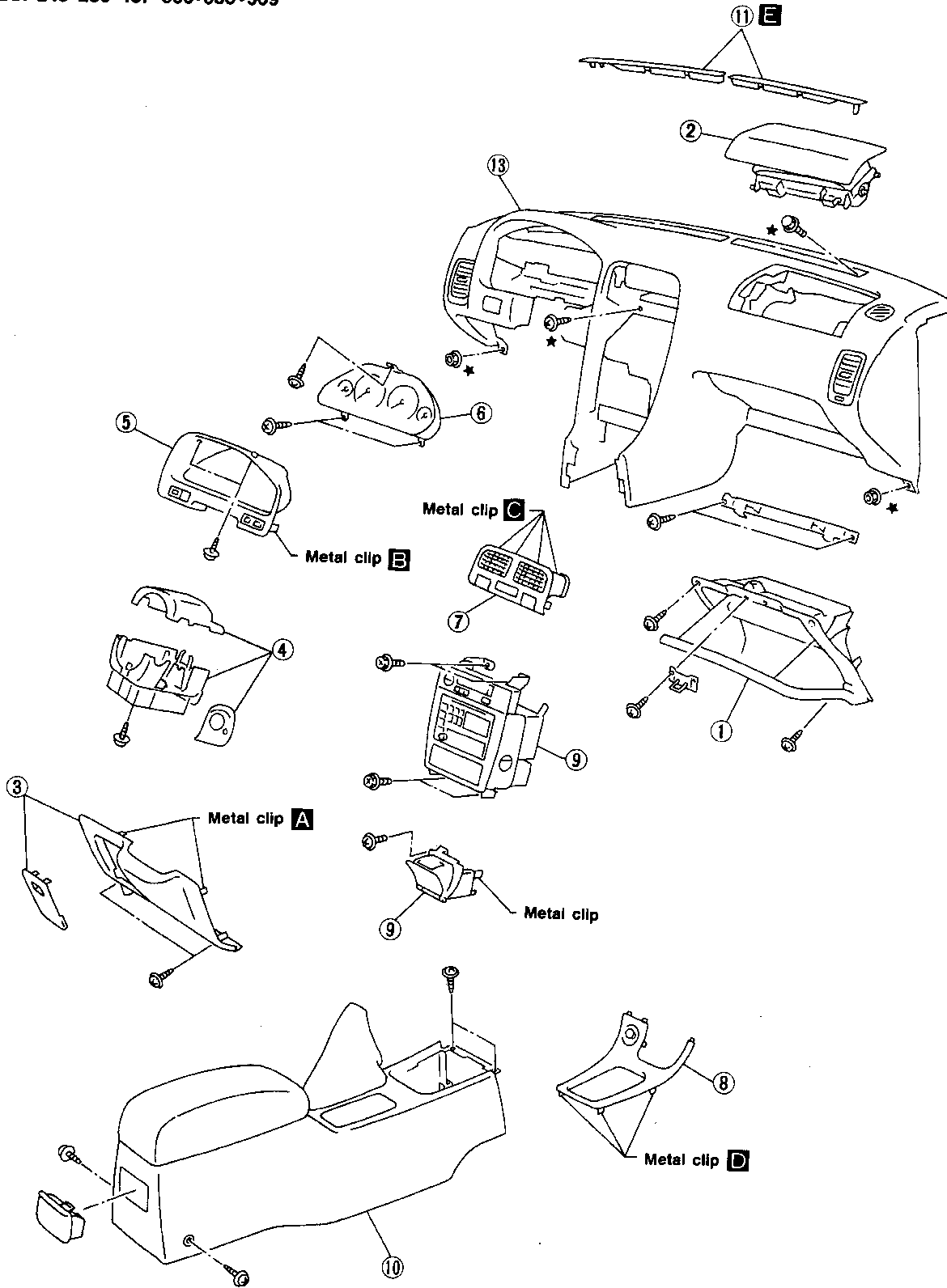

★: Instrument panel assembly mounting bolts, nuts and screws

# INSTRUMENT PANEL

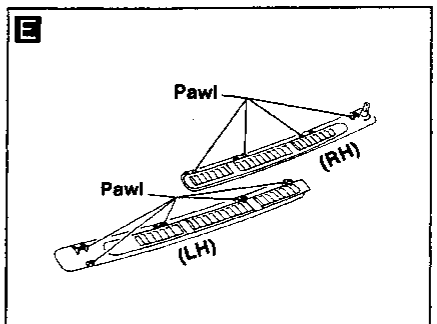
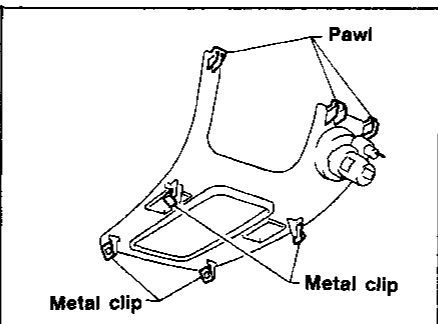
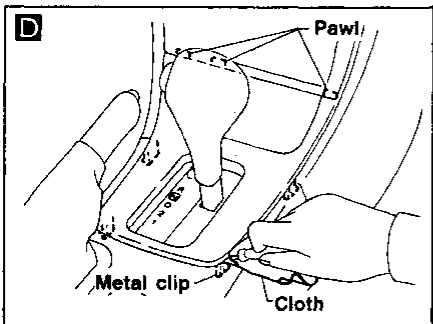
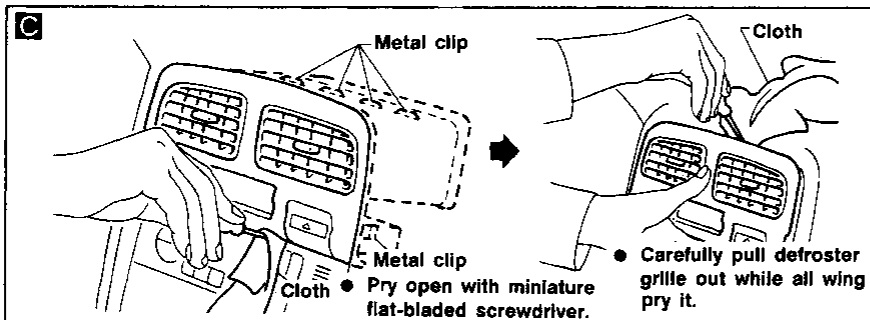
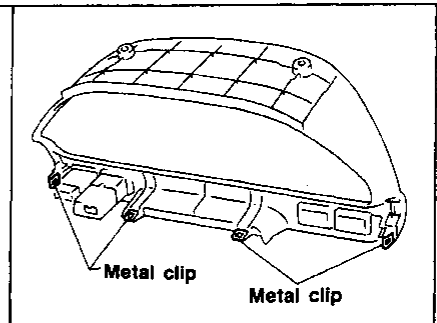
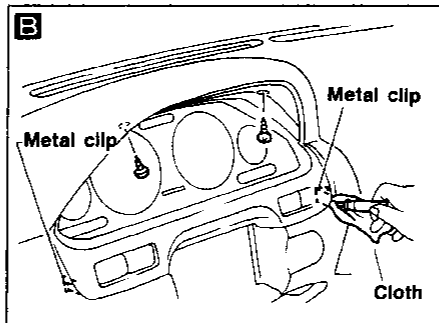
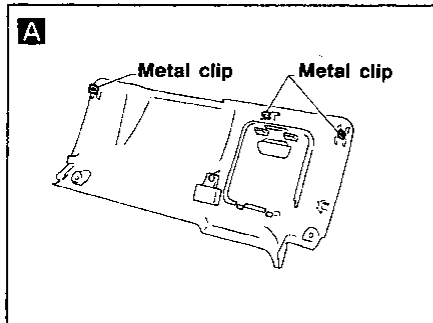

GI  
MA  
EM  
LC  
EC  
FE  
CL  
MT  
AT  
FA  
RA  
BR  
ST  
RS  
BT  
HA  
EL  
IDX

# INTERIOR TRIM

## Side and Floor Trim

### CAUTION:

Wrap the tip of flat-bladed screwdriver with a cloth when removing metal clips from garnishes.

### REMOVAL — Body side trim

- ① Remove front and rear seats. Refer to "SEAT" for details, BT-27.
- ② Remove front and rear kicking plates.
- ③ Remove dash side lower finishers.
- ④ Remove front and rear body side welts.
- ⑤ Remove front pillar garnishes.
- ⑥ Remove center pillar upper garnishes.
- ⑦ Remove center pillar lower garnishes.
- ⑧ Remove rear pillar garnishes.
- ⑨ Remove high-mounted stop lamp. (Model without rear air spoiler)
- ⑩ Remove rear parcel shelf finisher. (Remove center rear seat belt anchor bolt.)

SEC. 284•678•749•769•799

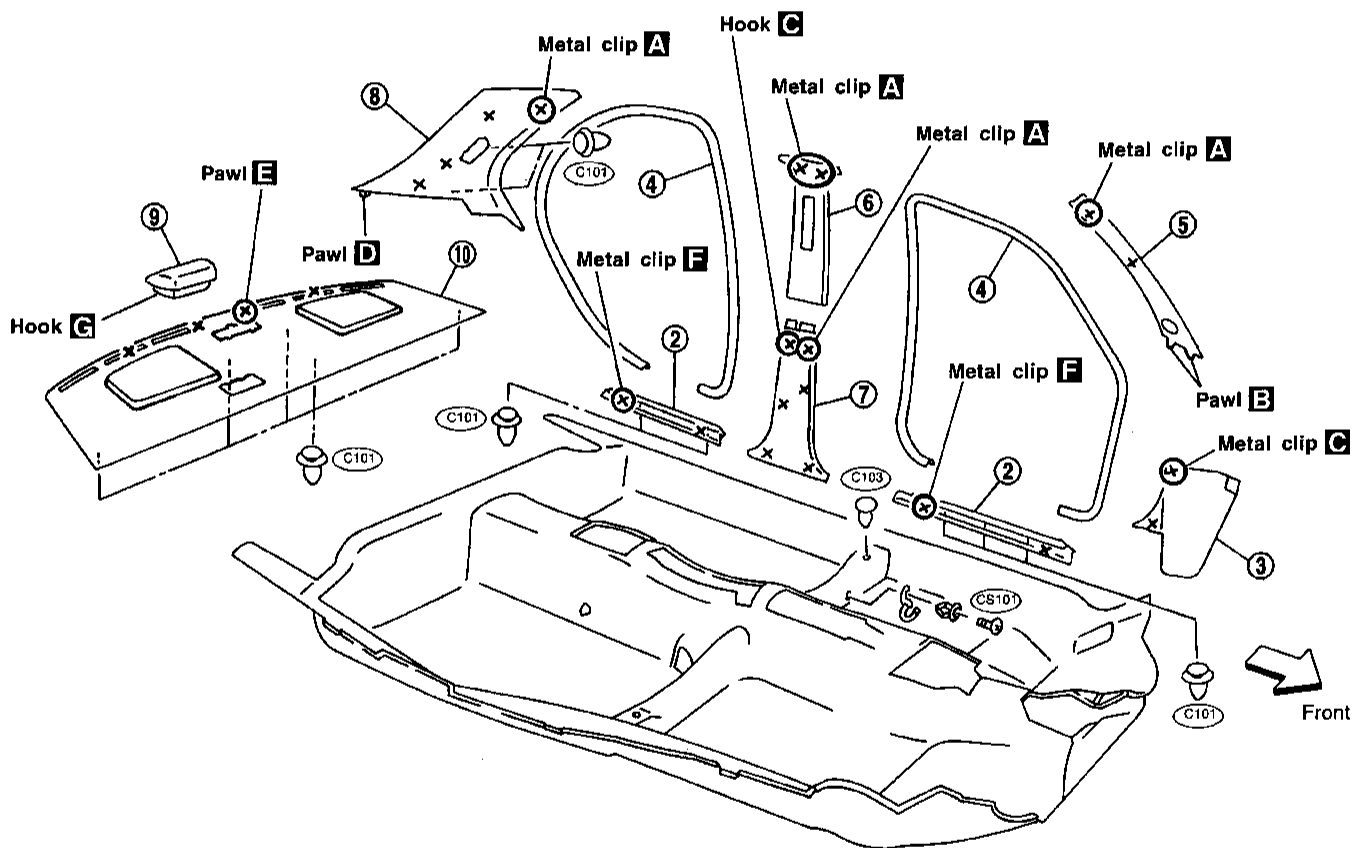

SBT648



# INTERIOR TRIM

## Side and Floor Trim (Cont'd)

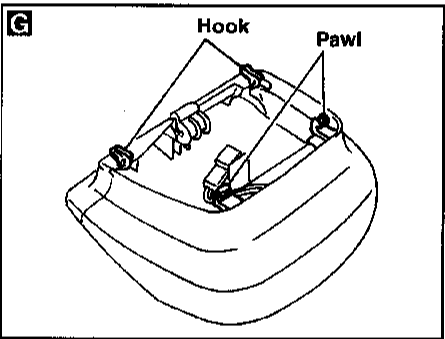
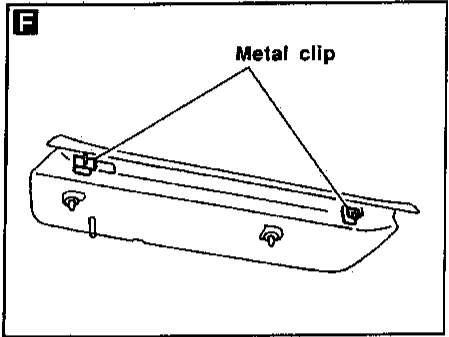
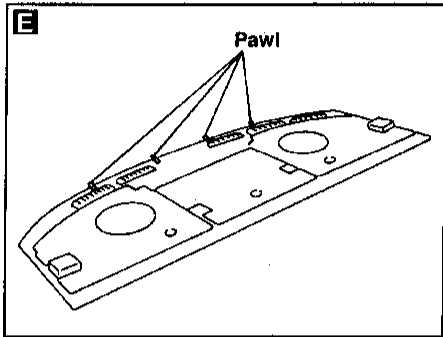
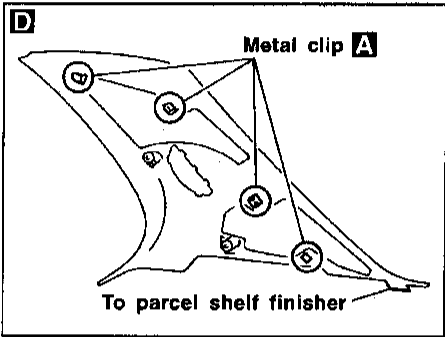
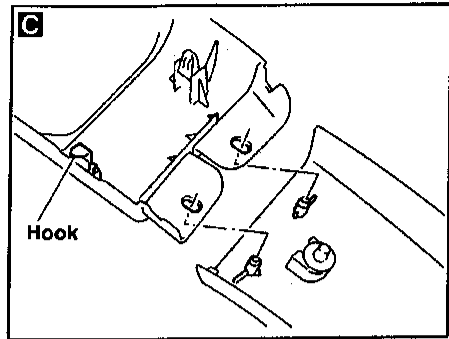
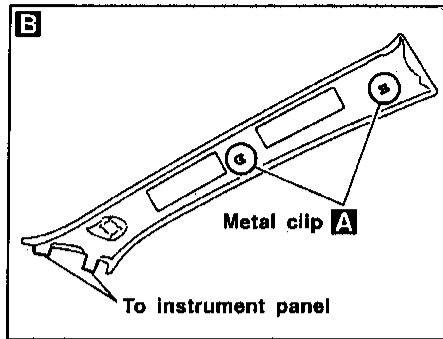
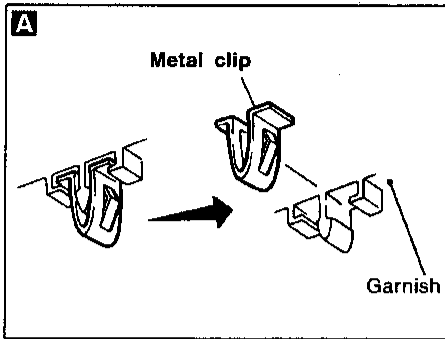

GI  
MA  
EM  
LC  
EC  
FE  
CL  
MT  
AT  
FA  
RA  
BR  
ST  
RS  
BT  
HA  
EL  
IDX

# INTERIOR TRIM

## Door Trim

### REMOVAL — Door trim

- ① Remove inside handle escutcheon.
- ② Remove power window switches, then disconnect the connectors.
- ③ Remove screw securing pull handle, and then remove pull handle.
- ④ Remove step lamp lens and screws securing step lamp, and then disconnect step lamp connector.
- ⑤ Remove screws securing door finisher.
- ⑥ Pull door finisher to remove clips from door panel and remove door finisher. Disconnect harness connectors.

SEC. 251-267-809-828

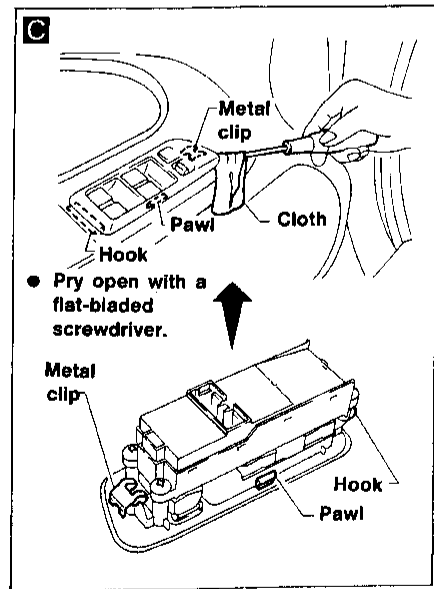
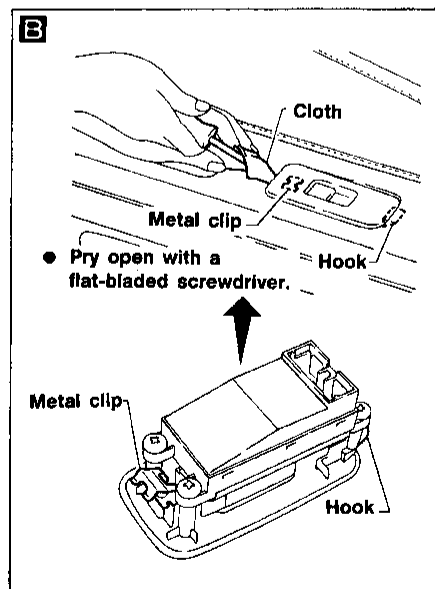
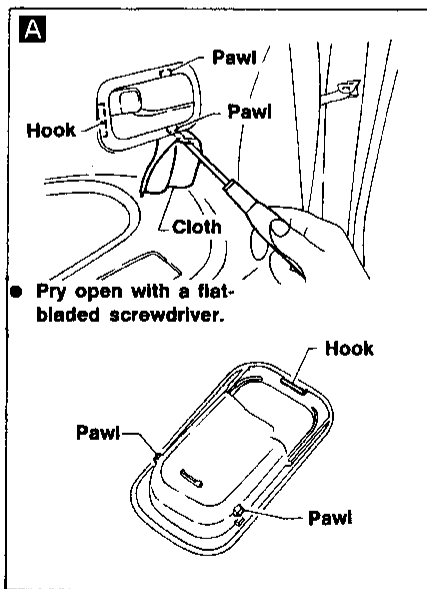
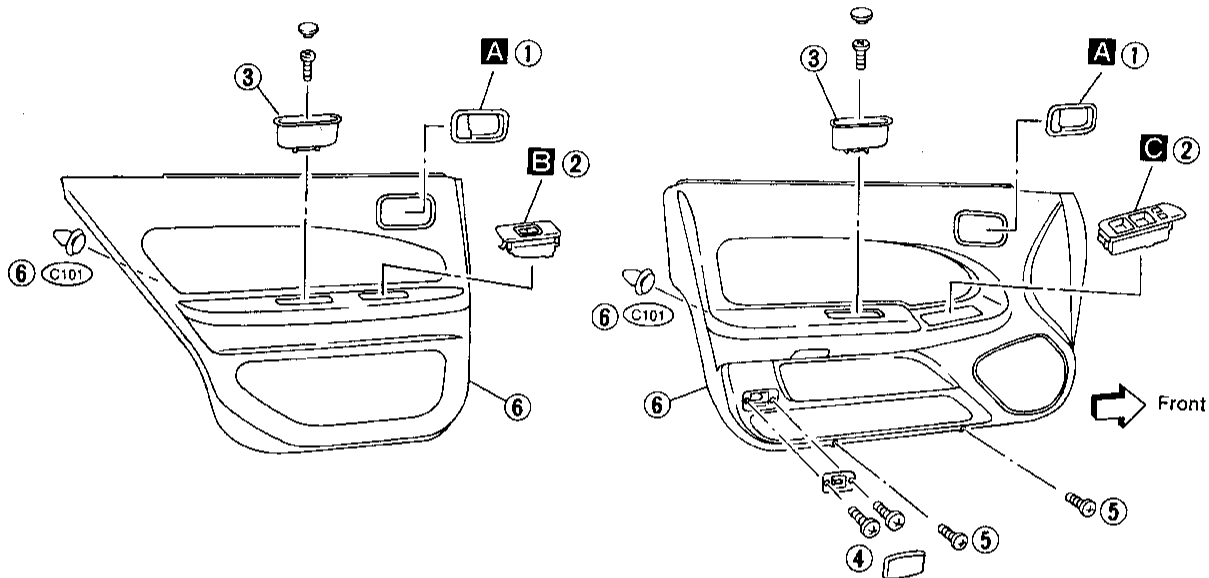

## Roof Trim

### REMOVAL — Headlining

- ① Remove front and rear seats. Refer to "SEAT" for details, BT-27.
- ② Remove front and rear seat belts. Refer to "SEAT BELTS" in RS section for details.
- ③ Remove body side trim. Refer to "Side and Floor Trim" for details, BT-16.
- ④ Remove sunroof switch or spot lamp switch.
- ⑤ Remove inside mirror assembly.
- ⑥ Disconnect automatic antidazzling inside mirror connector. (Equipped with automatic antidazzling inside mirror).
- ⑦ Remove sun visors.
- ⑧ Remove interior lamp assembly.
- ⑨ Remove assist grips.
- ⑩ Remove metal clips securing headlining.
- ⑪ Remove headlining.

SEC. 264-738-963-964

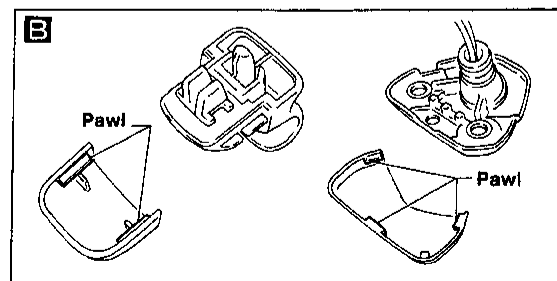
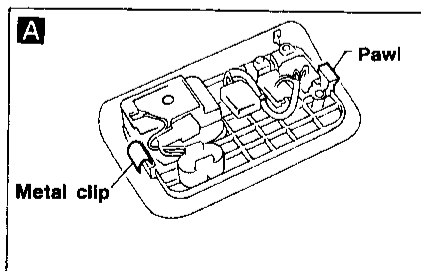
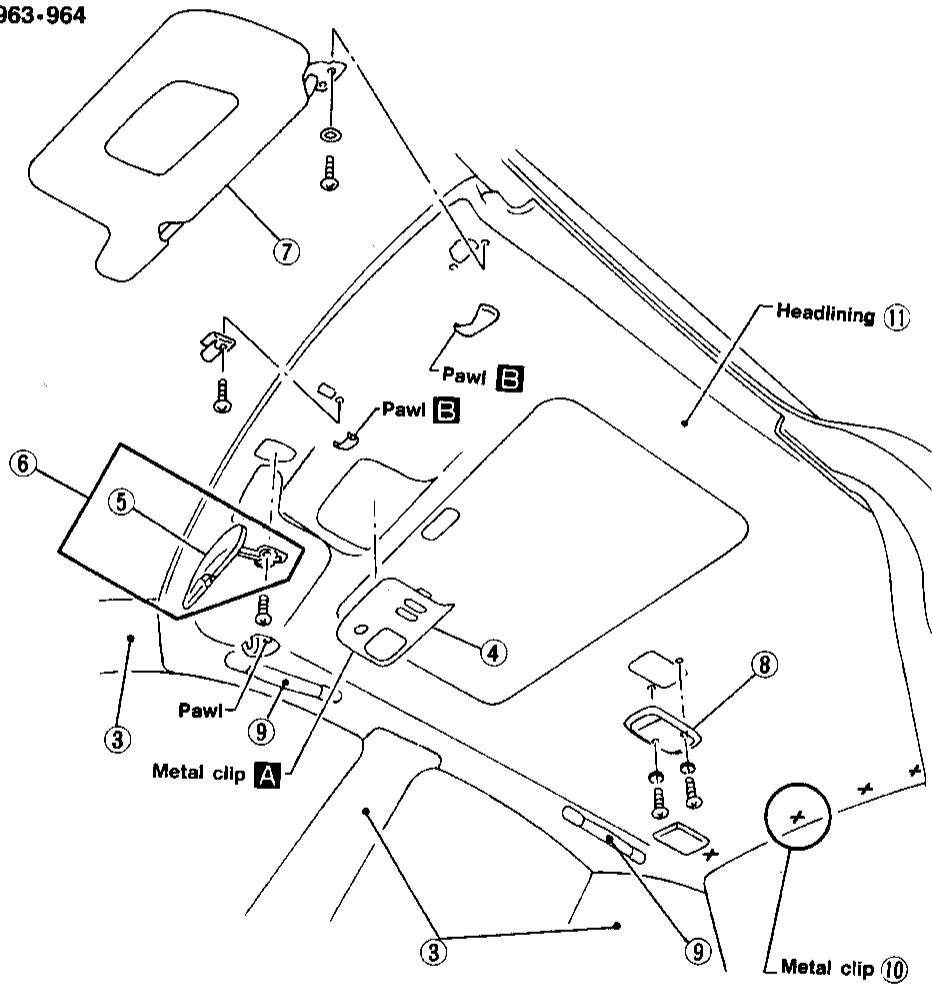

GI  
MA  
EM  
LC  
EC  
FE  
CL  
MT  
AT  
FA  
RA  
BR  
ST  
RS  
BT  
HA  
EL  
IDX

# INTERIOR TRIM

## Trunk Room Trim

SEC. 849

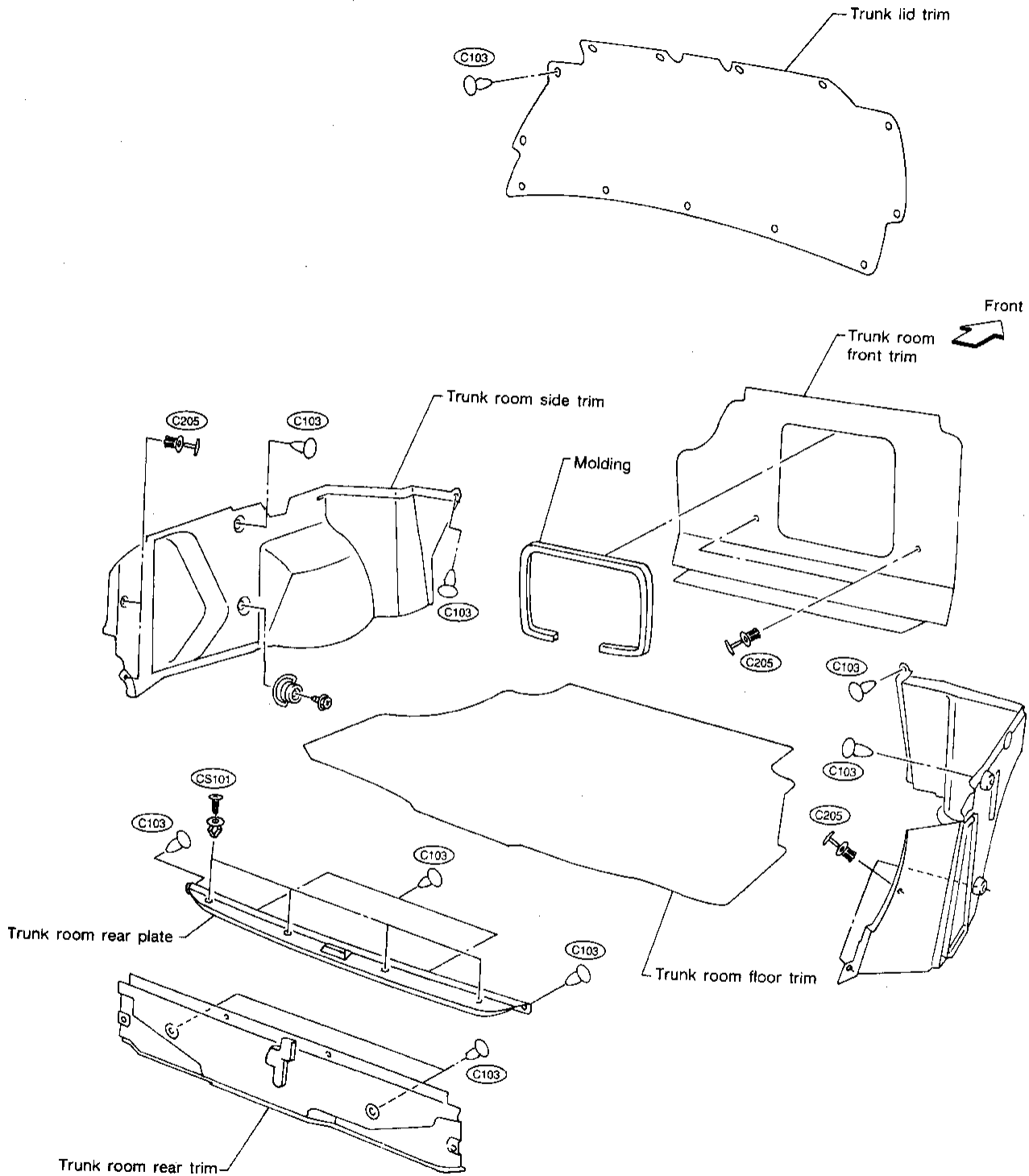

# EXTERIOR

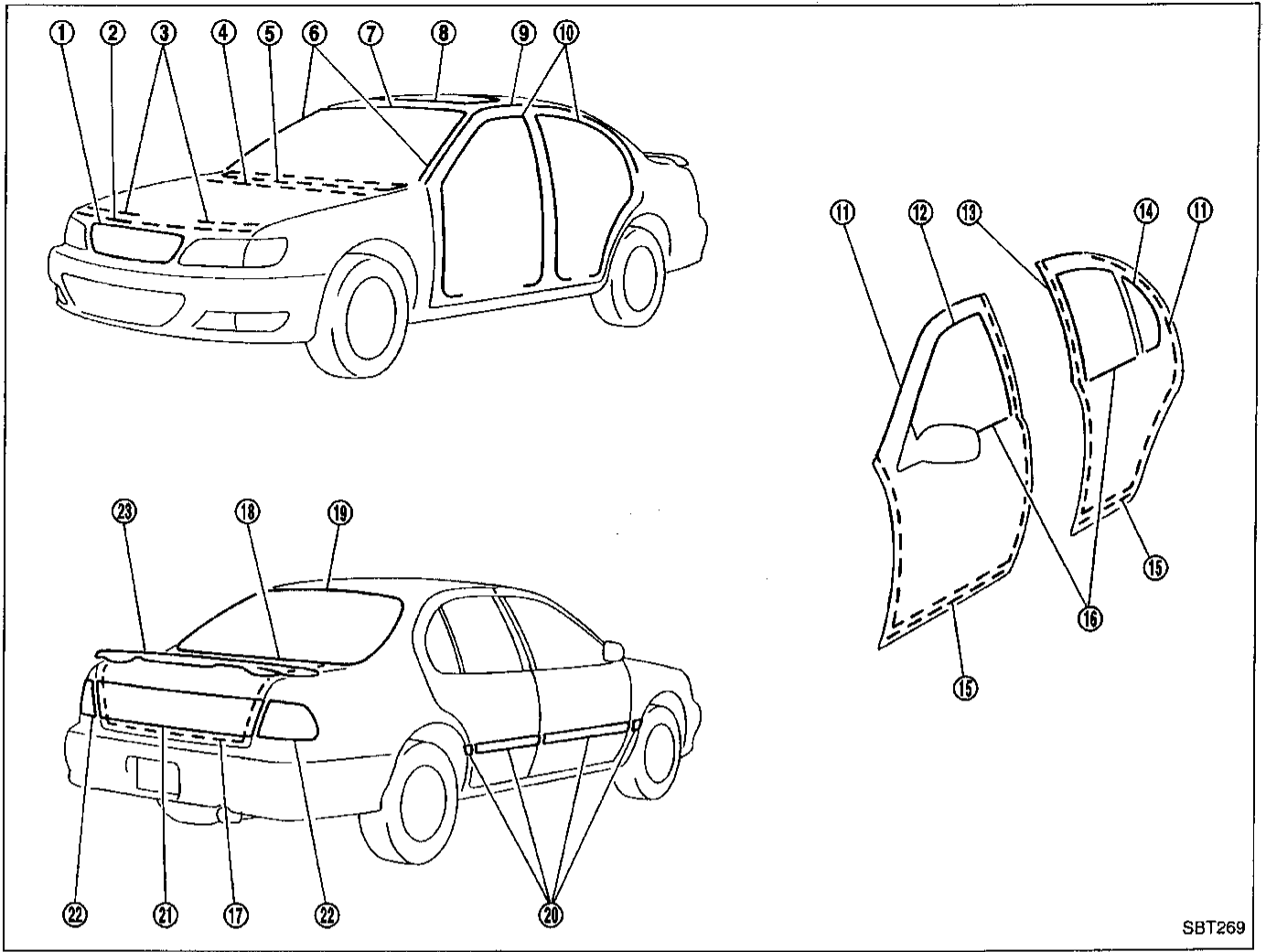

GI  
MA  
EM  
LC  
EC  
FE  
CL  
MT  
AT  
FA  
RA  
BR  
ST  
RS  
BT  
HA  
EL  
IDX

SBT269

## ① Front hood grille

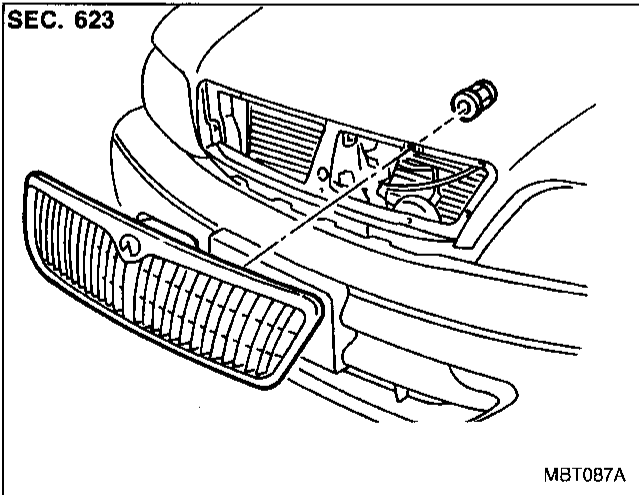

## ② ③ Hood front sealing rubber

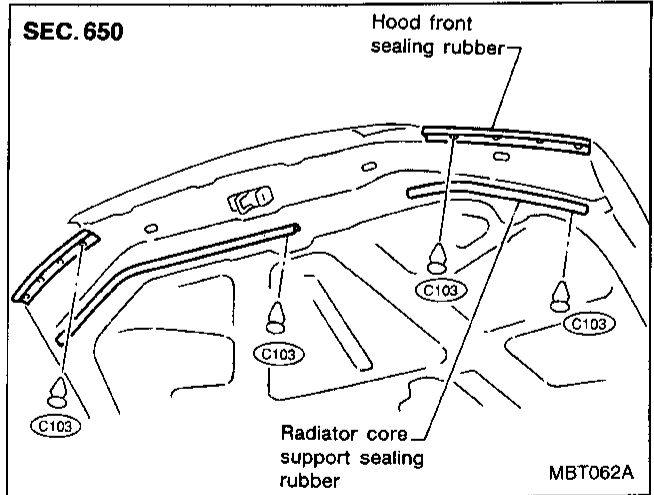

# EXTERIOR

## ④ ⑤ Cowl top seal and cowl top grille

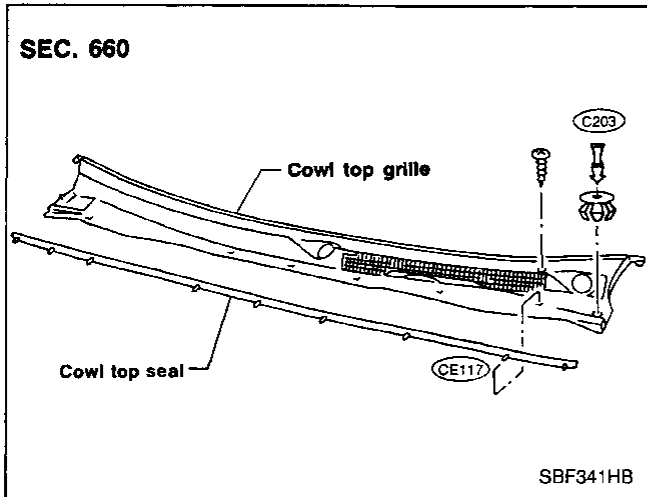

## ⑧ Sun roof lid weatherstrip

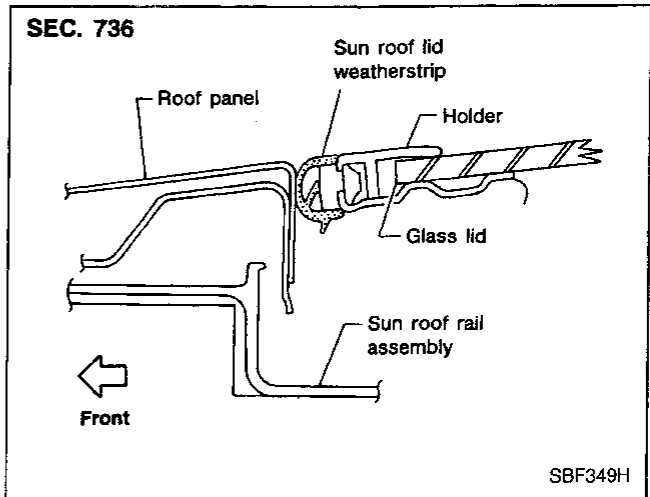

## ⑥ Windshield side molding

Mounted with screws.

## ⑦ Windshield upper molding

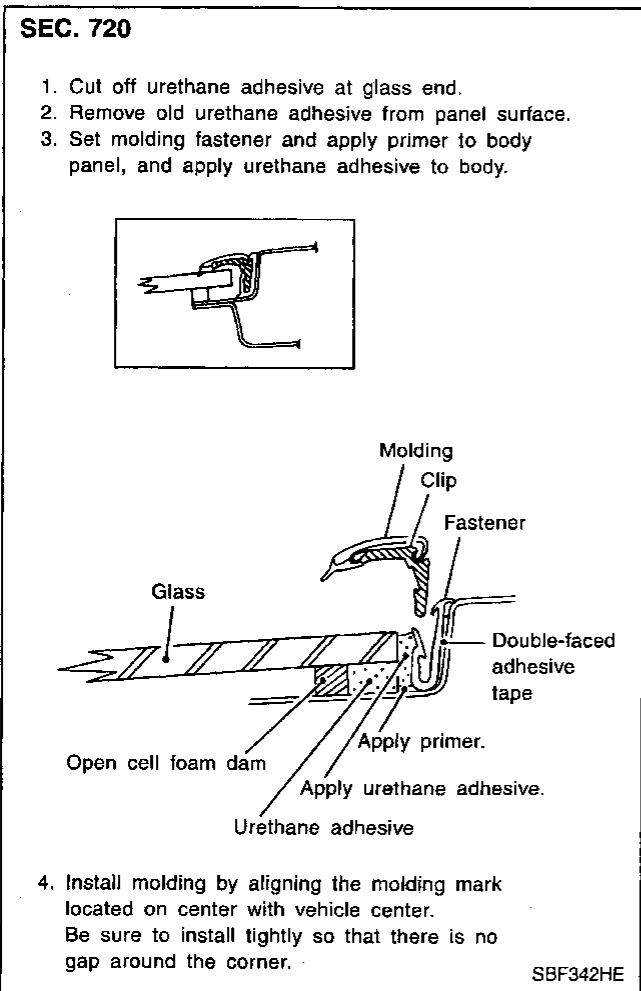

## ⑨ Drip weatherstrip

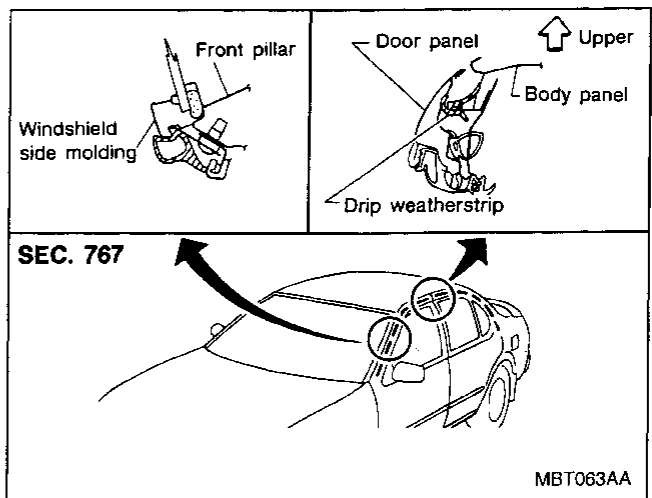

## ⑩ Body side welt

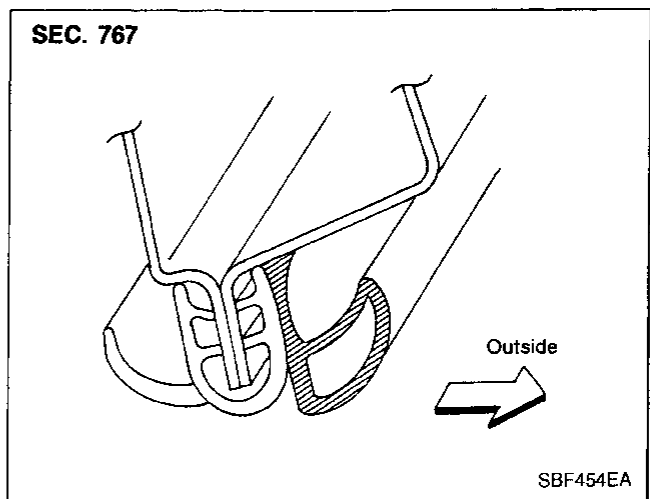

⑪ Door weatherstrip

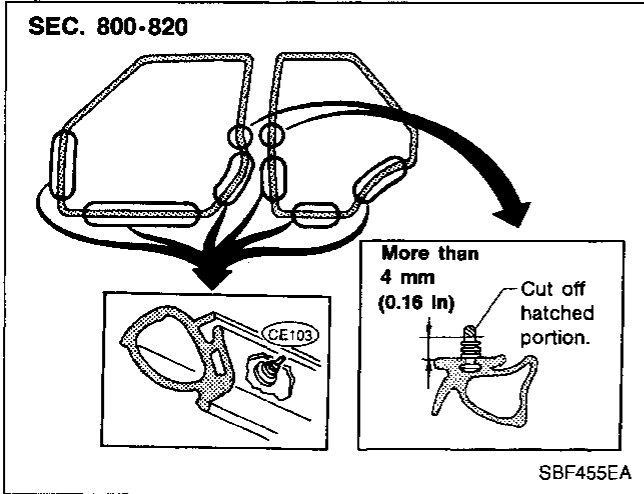

⑬ Front door parting seal

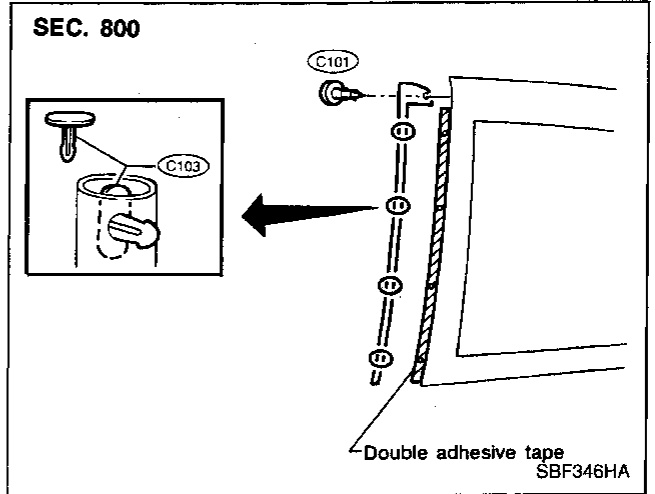

⑫ Door sash molding

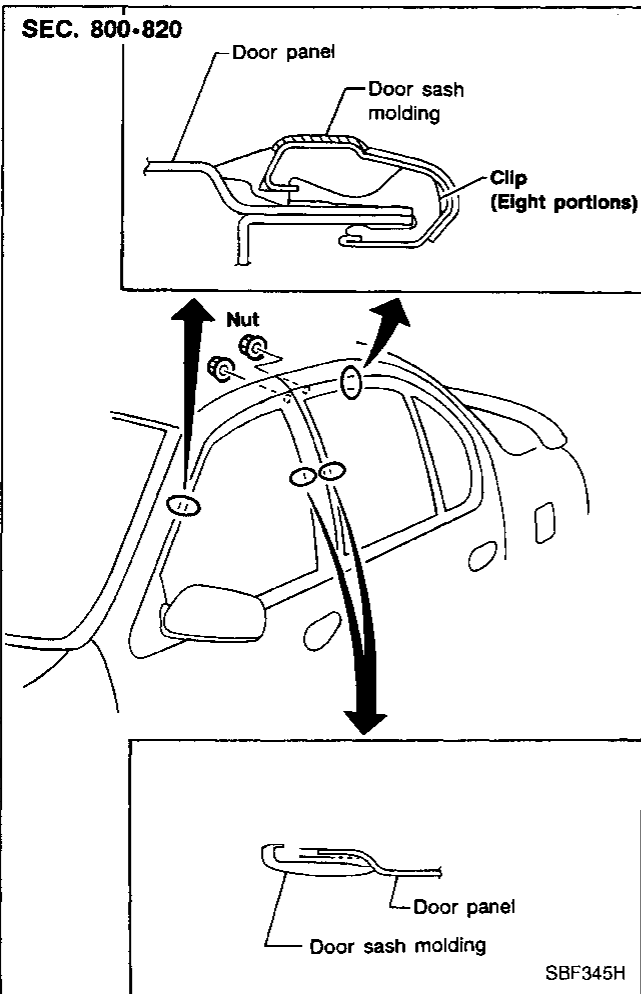

⑭ Rear door corner molding

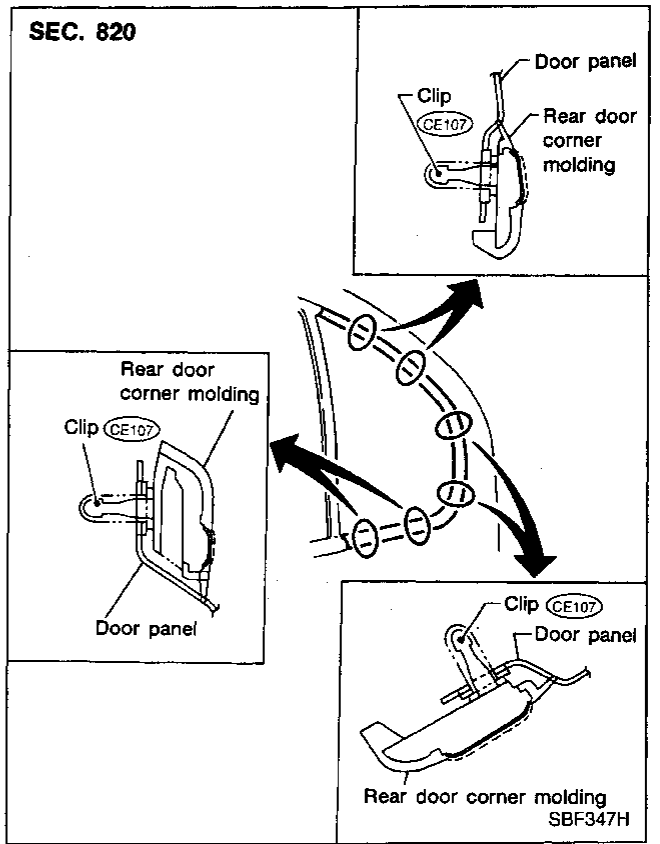

GI  
MA  
EM  
LC  
EC  
FE  
CL  
MT  
AT  
FA  
RA  
BR  
ST  
RS  
BT  
HA  
EL  
IDX

## 15 Door parting seal

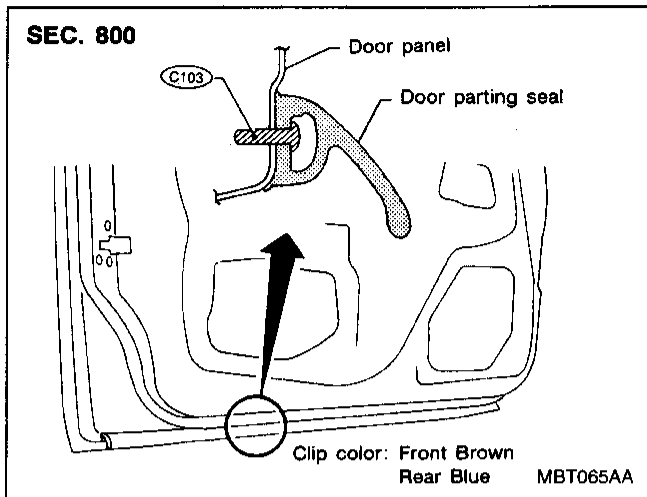

## 17 Trunk lid weatherstrip

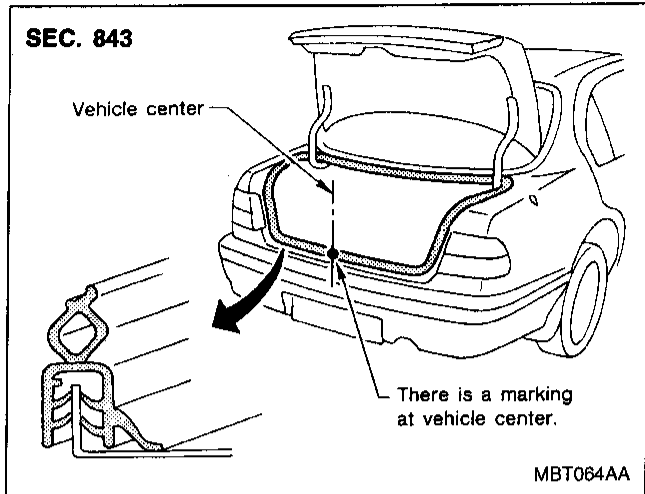

## 16 Door outside molding

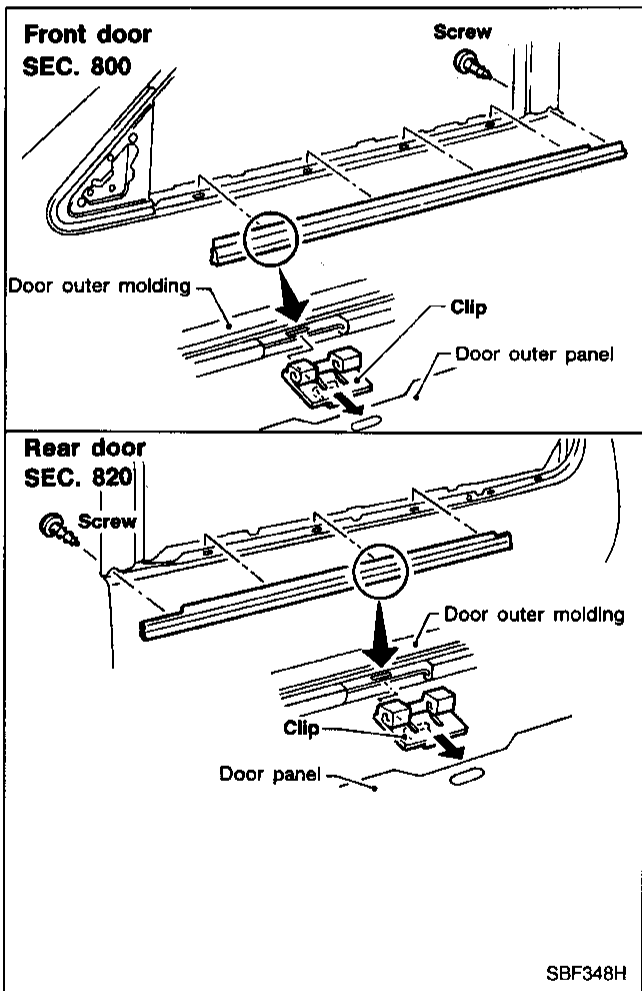

## 18 Rear window lower molding

Mounted with screws.

## 19 Rear window upper molding and side molding

Basically the same as windshield upper molding. Refer to 7 Windshield upper molding.



②① Side guard molding

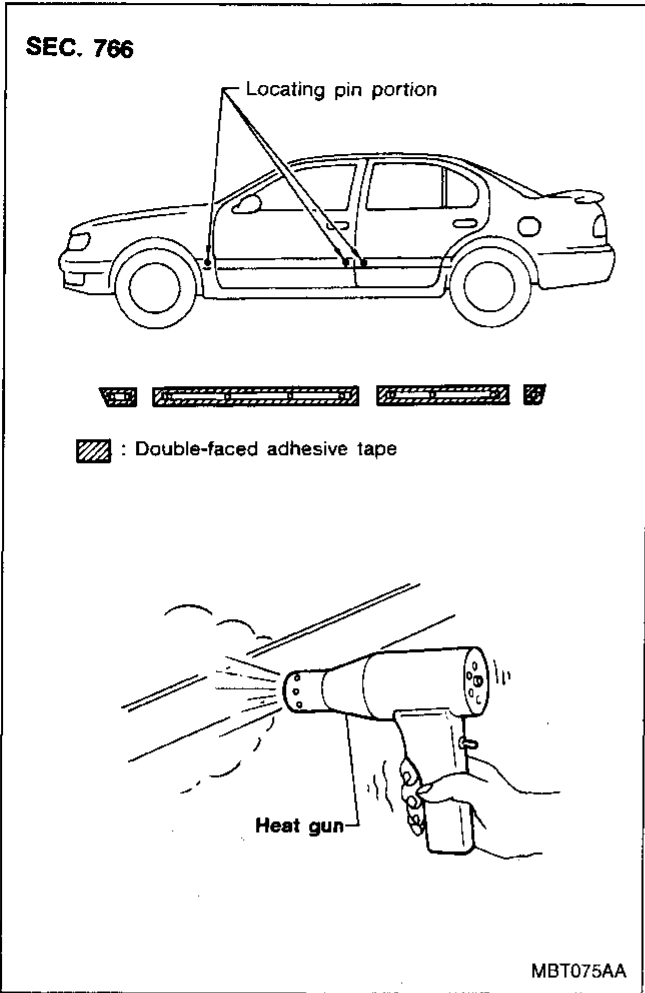

- With a vehicle coated with Hard Clear Coat, use double-faced 3M adhesive tape Product No. 4210 or equivalent, after priming with 3M primer Product No. N-200 or C-100 or equivalent.

②① Rear panel finisher

- Rear panel finisher is installed with nuts, clips and butyl sealant.

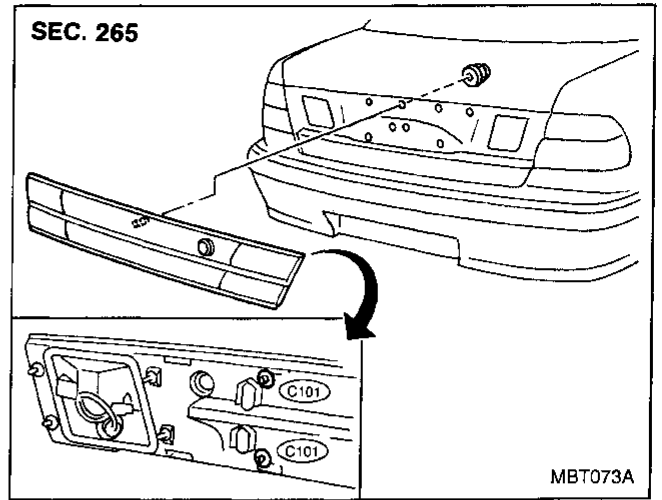

GI  
MA  
EM  
LC  
EC  
FE  
CL  
MT  
AT  
FA  
RA  
BR  
ST  
RS  
BT  
HA  
EL  
IDX

## 22 Rear combination lamp

- Rear combination lamps are installed with nuts and butyl sealant.

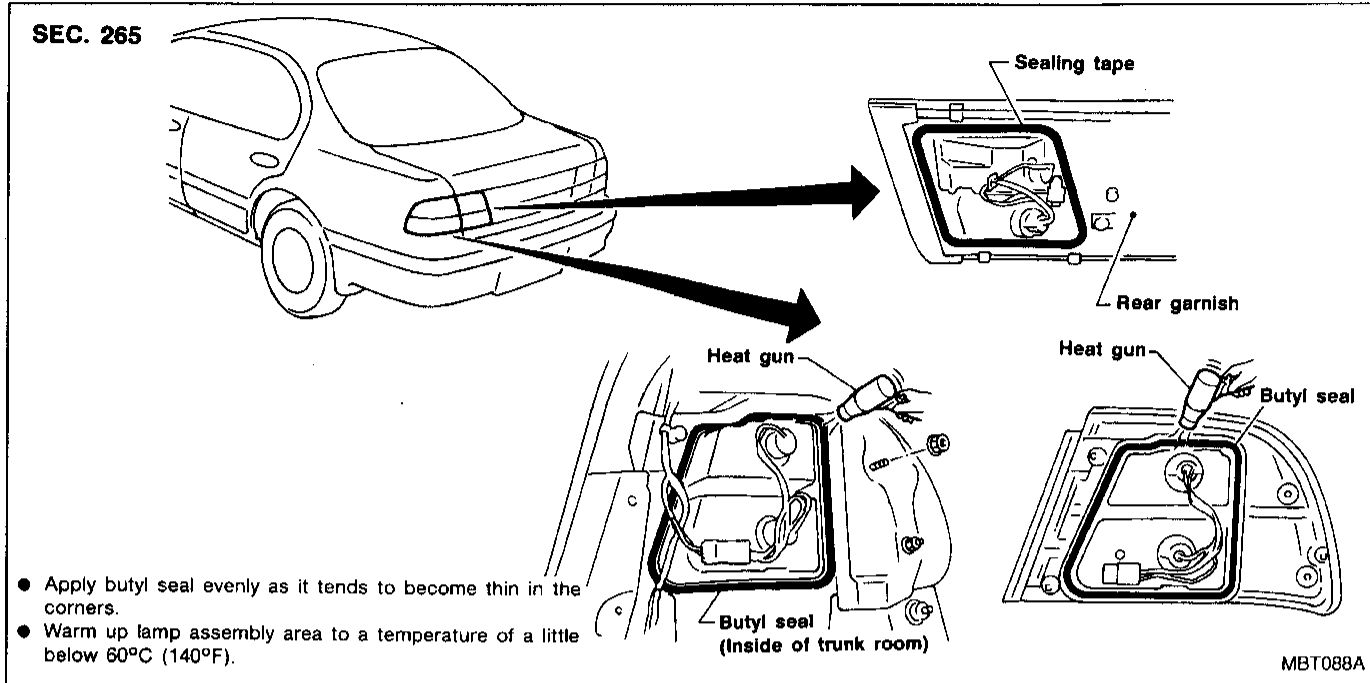

## 23 Rear air spoiler

- When installing, make sure that there are not gaps or waves at ends of air spoiler.
- Before installing spoiler, clean and remove oil from surface where spoiler will be mounted.

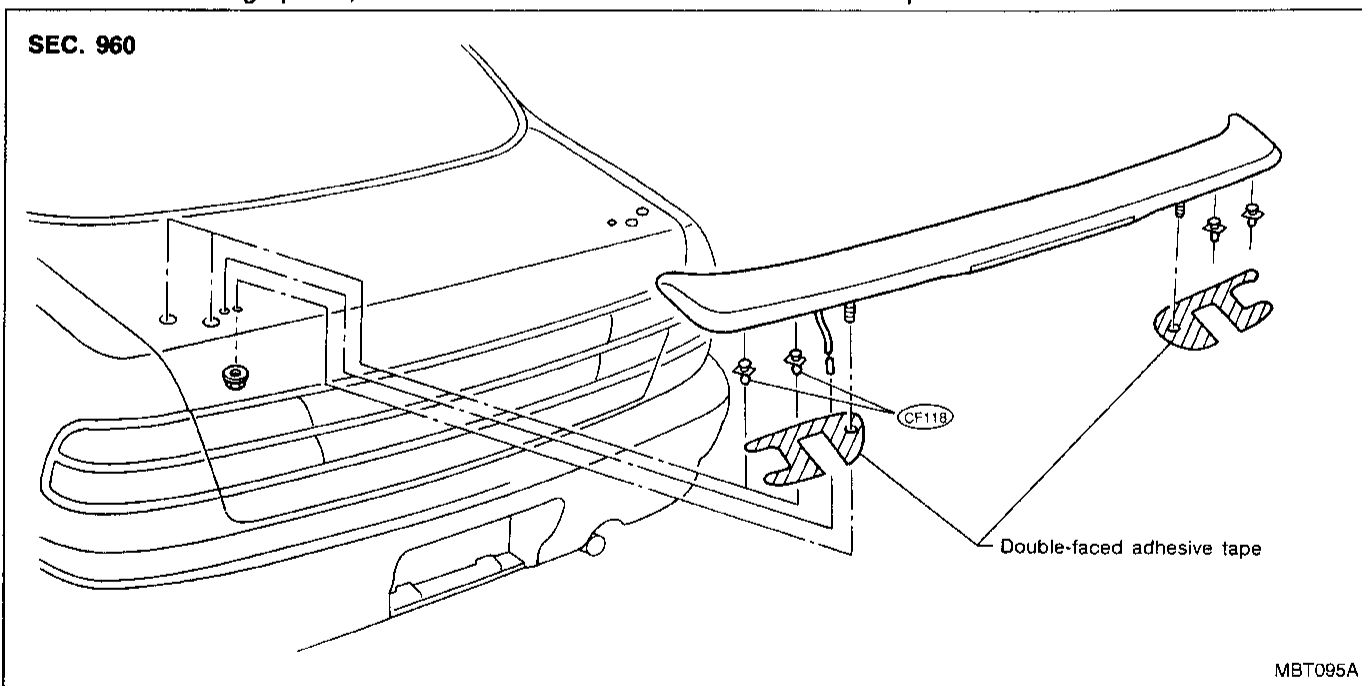

# SEAT

---

- When removing or installing the seat trim, carefully handle it to keep dirt out and avoid damage.
- ★ For Wiring Diagram, refer to “POWER SEAT” in EL section.

**CAUTION:**

- Before removing the front seat, turn the ignition switch off, disconnect both battery cables and wait at least 3 minutes.
- When checking the power seat circuit for continuity using a circuit tester, do not confuse its connector with the side air bag module connector. Such an error may cause the air bag to deploy.
- Do not drop, tilt, or bump the side air bag module installed in the seat. Always handle it with care.

GI

MA

EM

LC

EC

FE

CL

MT

AT

FA

RA

BR

ST

RS

**BT**

HA

EL

IDX

# SEAT

## Front Seat

SEC. 870

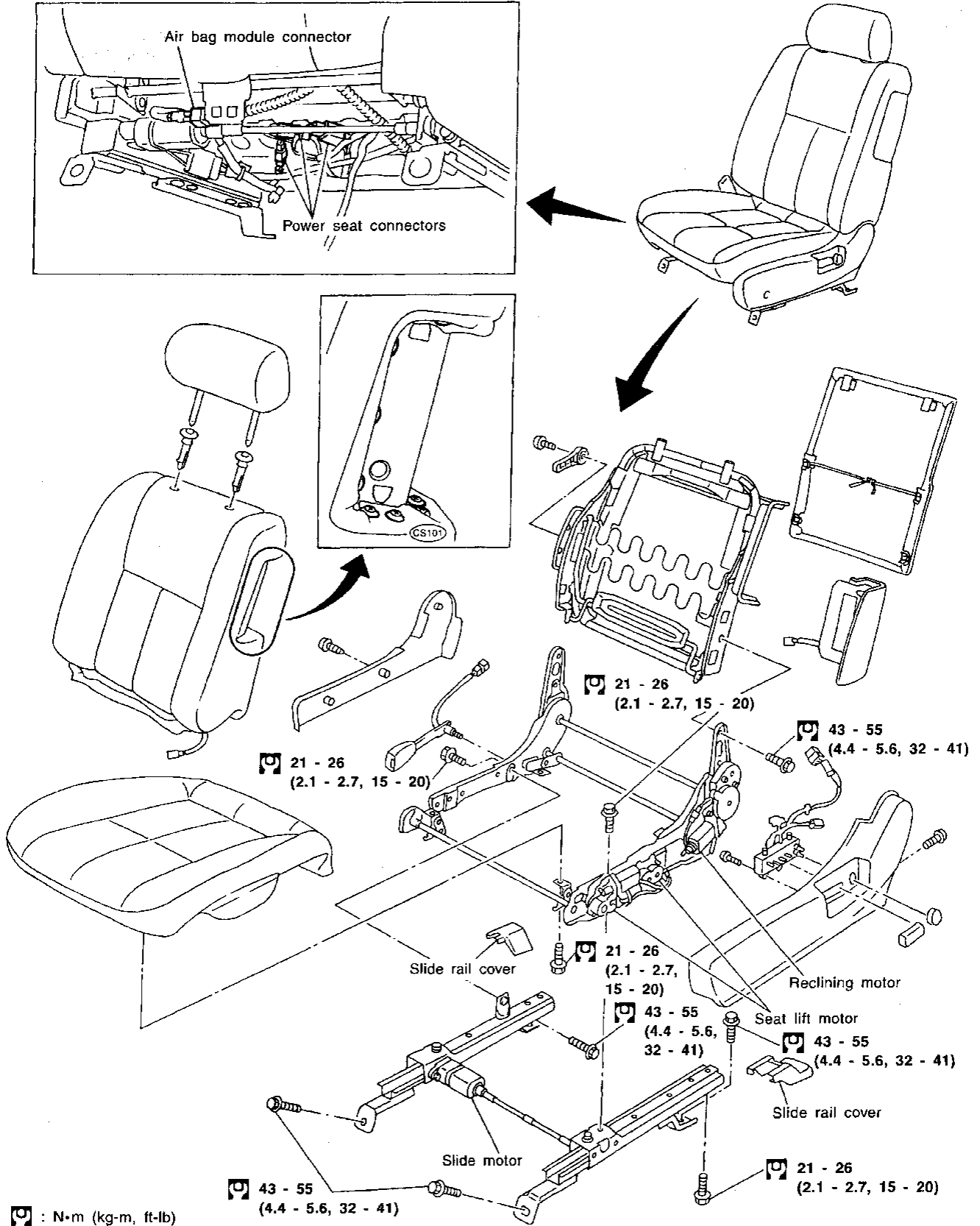
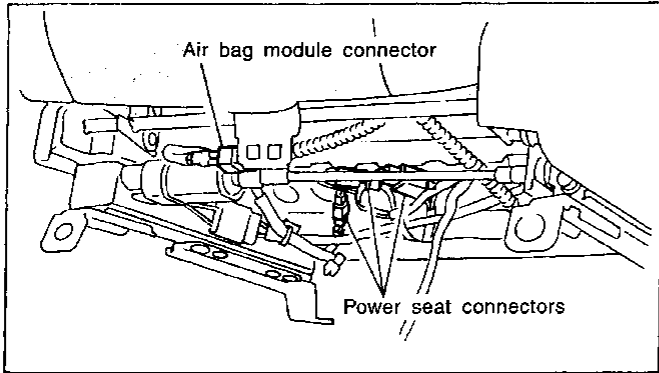

: N·m (kg·m, ft·lb)

## Heated Seat

- When handling seat, be extremely careful not to scratch heating unit.
- To replace heating unit, seat trim and pad should be separated.
- Do not use any organic solvent, such as thinner, benzene, alcohol, gasoline, etc. to clean trims.

### Seatback heating unit removal & installation

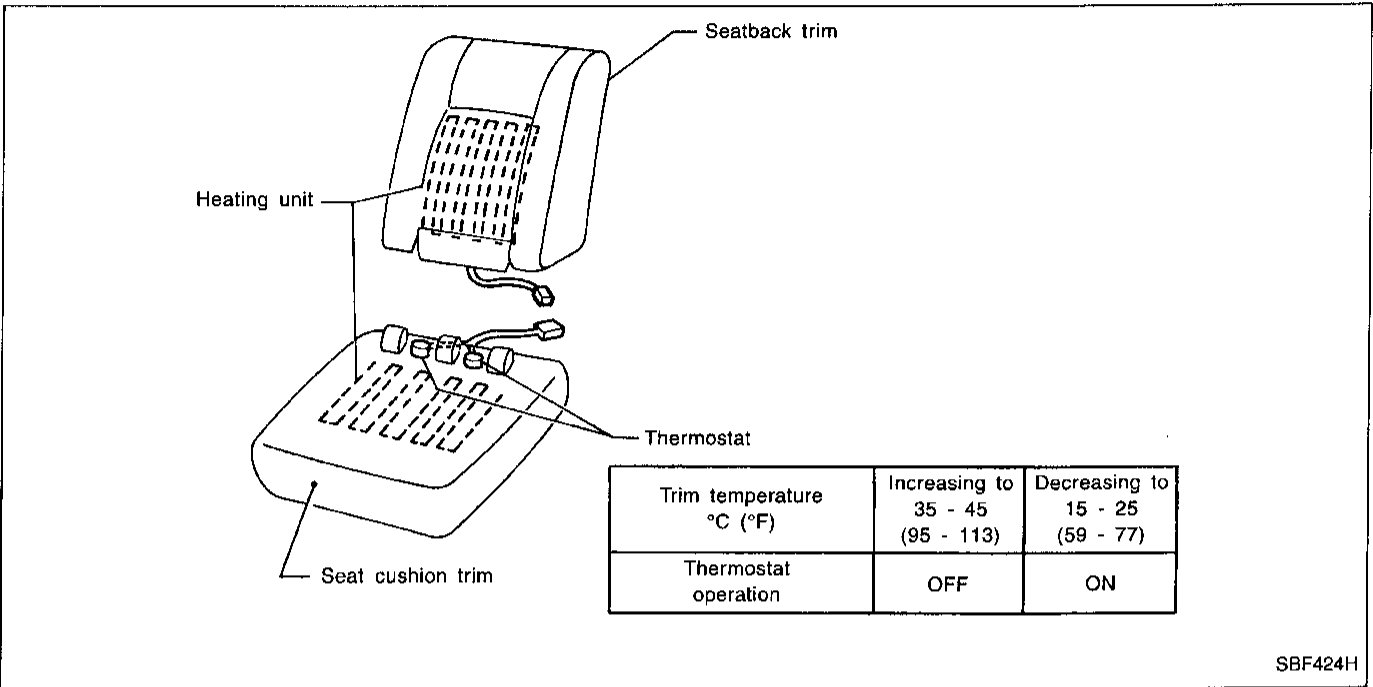

SBF424H

★ For Wiring Diagram, refer to "HEATED SEAT" in EL section.

GI  
 MA  
 EM  
 LC  
 EC  
 FE  
 CL  
 MT  
 AT  
 FA  
 RA  
 BR  
 ST  
 RS  
**BT**  
 HA  
 EL  
 IDX

Rear Seat

SEC. 880

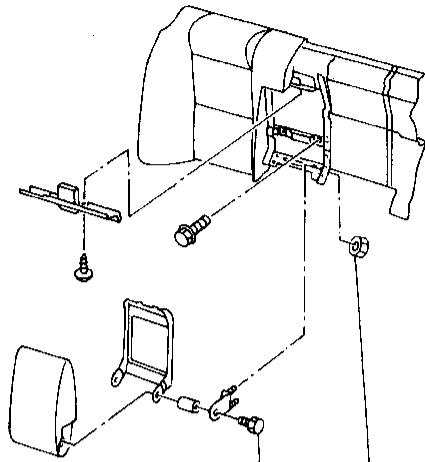

 5.1 - 6.5 (0.52 - 0.66, 45.1 - 57.3)

 5.1 - 6.5 (0.52 - 0.66, 45.1 - 57.3)

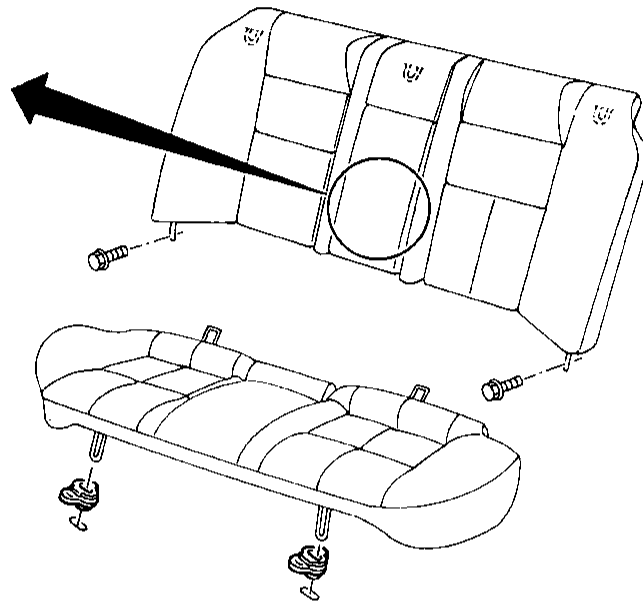

 : N·m (kg·m, in·lb)

MBT077AA

# SUNROOF

## ADJUSTMENT

Install motor & limit SW assembly and sunroof rail assembly in the following sequence:

1. Arrange equal lengths of link and wire assemblies on both sides of sunroof opening.
2. Connect sunroof connector to sunroof switch and positive (+) power supply.
3. Set lid assembly to fully closed position **A** by operating OPEN switch and TILT switch.
4. Fit outer side of lid assembly to the surface of roof on body outer panel.
5. Remove motor, and keep OPEN switch pressed until motor pinion gear reaches the end of its rotating range.
6. Install motor.
7. Check that motor drive gear fits properly in wires.
8. Press TILT-UP switch to check lid assembly for normal tilting.
9. Check sunroof lid assembly for normal operations (tilt-up, tilt-down, open, and close).

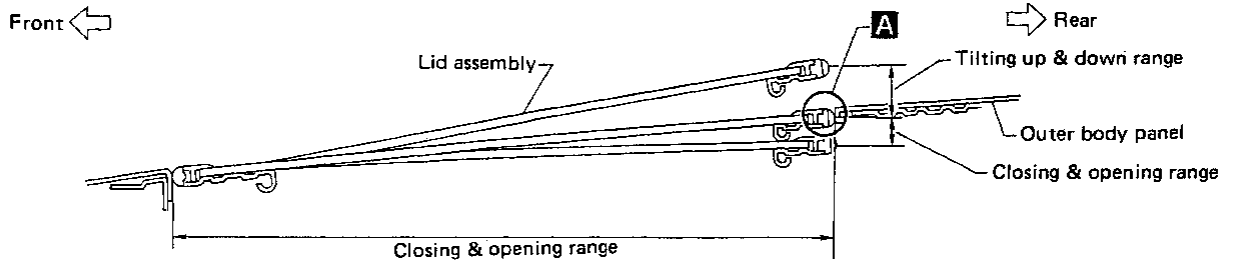

SBF920F

GI

MA

EM

LC

EC

FE

CL

MT

AT

FA

RA

BR

ST

RS

**BT**

HA

EL

IDX

# SUNROOF

## REMOVAL

- After any adjustment, check sun roof operation and lid alignment.
- Handle finisher plate and glass lid with care so not to cause damage.
- It is desirable for easy installation to mark each point before removal.

### CAUTION:

Always work with a helper.

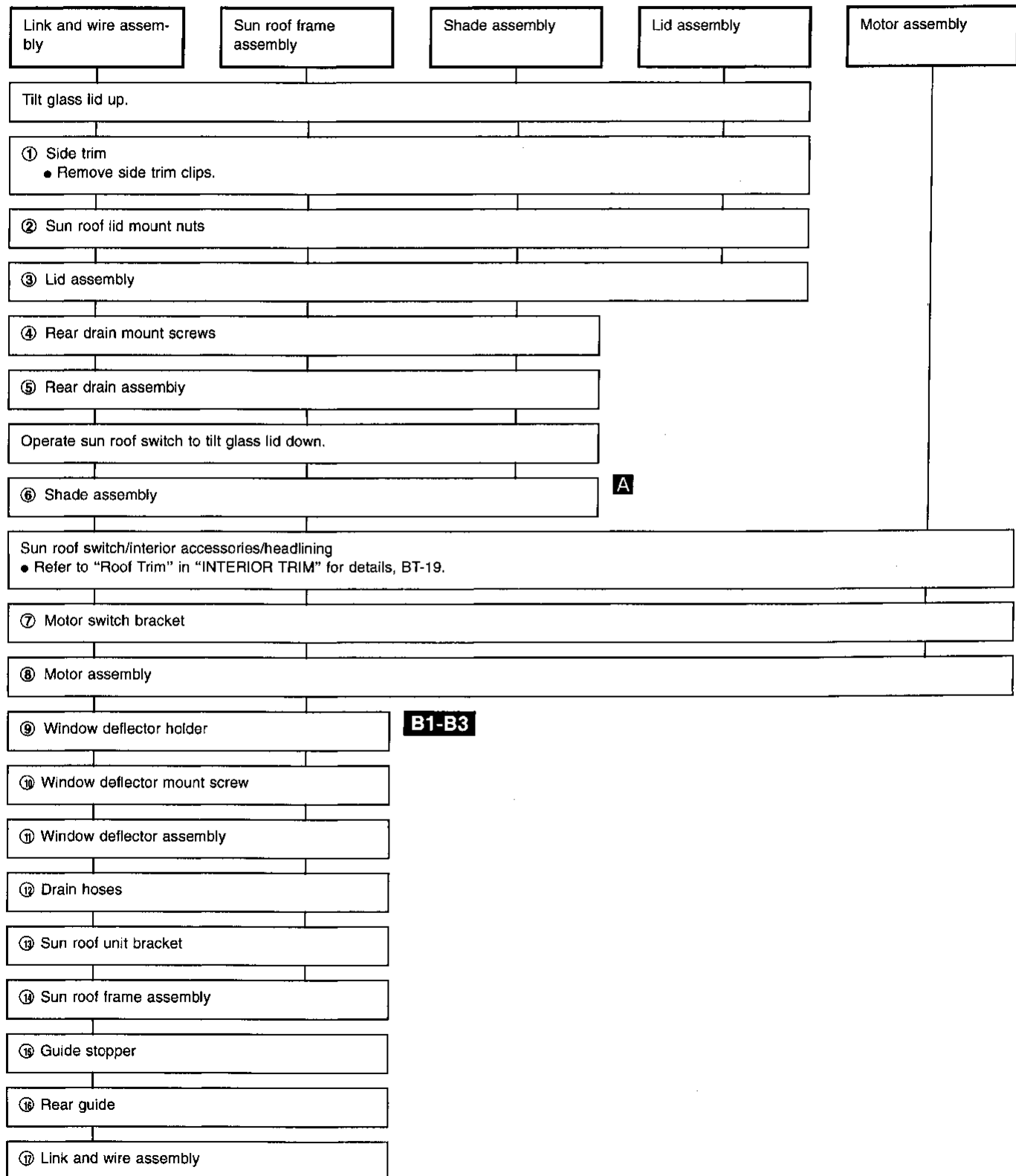



# SUNROOF

★ For Wiring Diagram, refer to "ELECTRIC SUN ROOF" in EL section.

SEC. 264

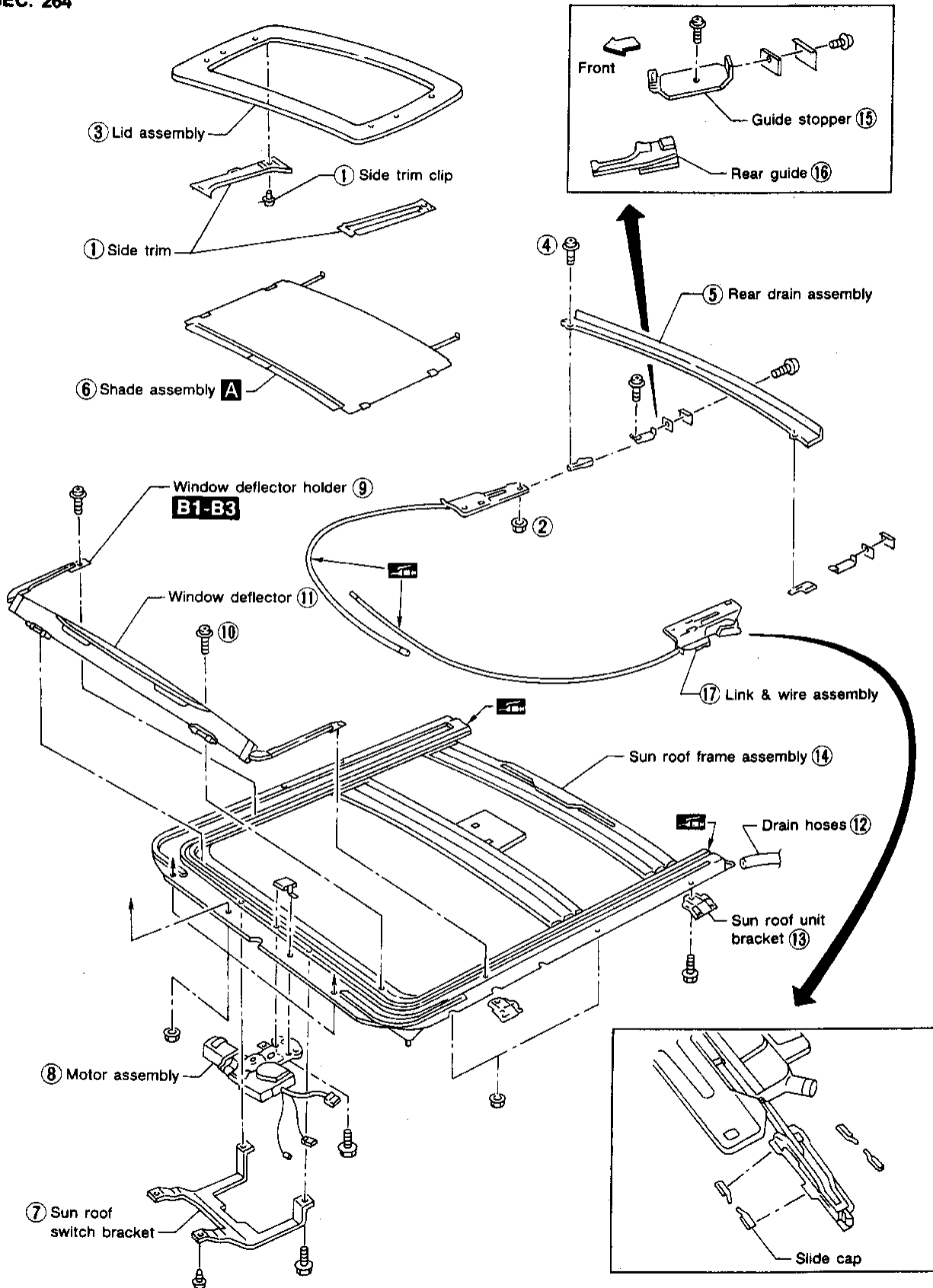

GI  
MA  
EM  
LC  
EC  
FE  
CL  
MT  
AT  
FA  
RA  
BR  
ST  
RS  
BT  
HA  
EL  
IDX

# SUNROOF

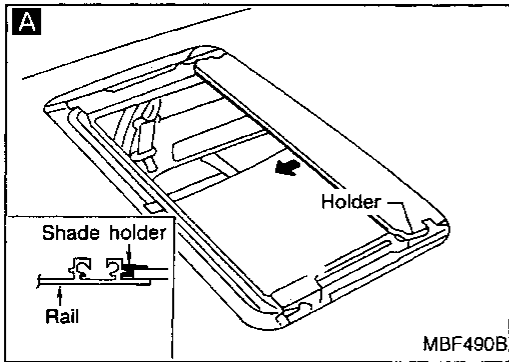

- A** Using flat-bladed screwdriver, pry shade assembly holder off rail. Then pull shade assembly forward to remove it from rail.

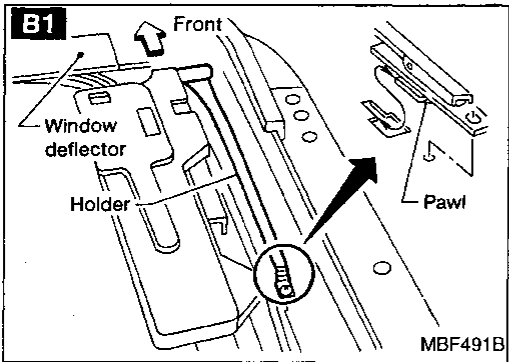

- B1** Disengage pawls from rail, then remove window deflector holder.

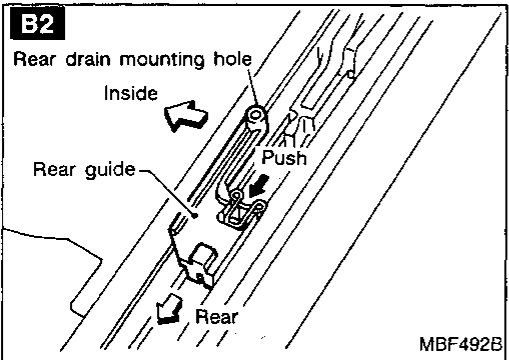

- B2** Using flat-bladed screwdriver, pry stopper spring off rail groove. Then slide rear guide backward to remove it from rail.

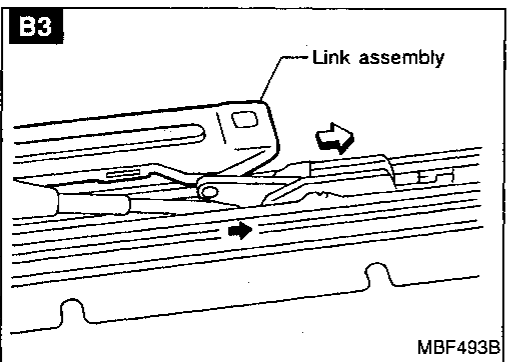

- B3** Remove wire and link assembly from rail while pushing link back with flat-bladed screwdriver.

## Trouble Diagnoses

### DIAGNOSTIC TABLE

NOTE: For diagnosing electric problem, refer to "ELECTRIC SUNROOF" in EL section.

		Check items (Components)				
		Wind deflector	Adjustment	Drain hoses	Weatherstrip	Link and wire assembly
	Reference page	BT-35	BT-36	BT-37	BT-37	BT-38
Symptom	Excessive wind noise	1	2		3	
	Water leaks		1	2	3	
	Sunroof rattles		1	4	2	3
	Excessive operation noise		1		2	3

The numbers in this table mean checking order.

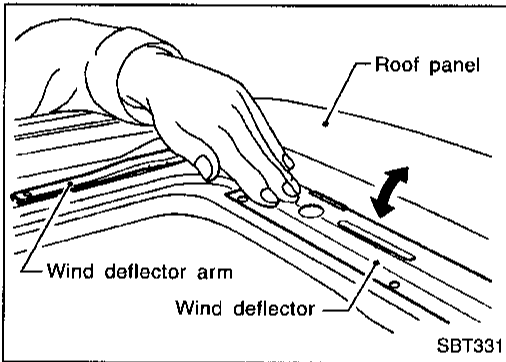

### WIND DEFLECTOR

1. Open lid.
2. Check visually for proper installation.
3. Check to ensure a proper amount of petroleum jelly has been applied to wind deflector connection points; apply if necessary.
4. Check that wind deflector is properly retracted by hand. If it is not, remove and visually check condition. (Refer to removal procedures, BT-32.) If wind deflector is damaged, replace with new one. If wind deflector is not damaged, re-install properly.

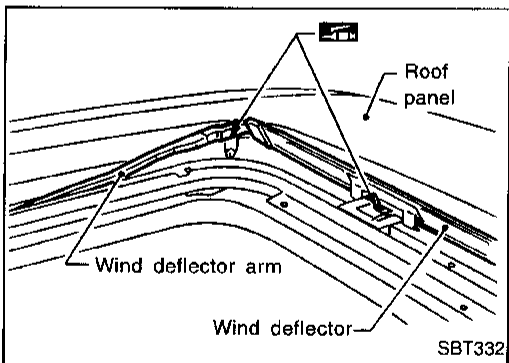

GI

MA

EM

LC

EC

FE

CL

MT

AT

FA

RA

BR

ST

RS

BT

HA

EL

IDX

# SUNROOF

## Trouble Diagnoses (Cont'd)

### ADJUSTMENT

If any gap or height difference between glass lid and roof is found, check glass lid fit and adjust as follows:

SEC. 736

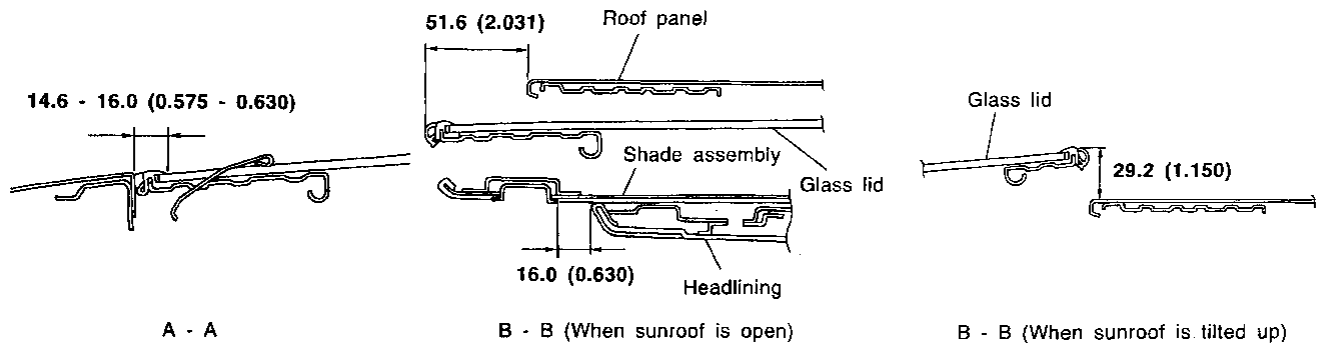
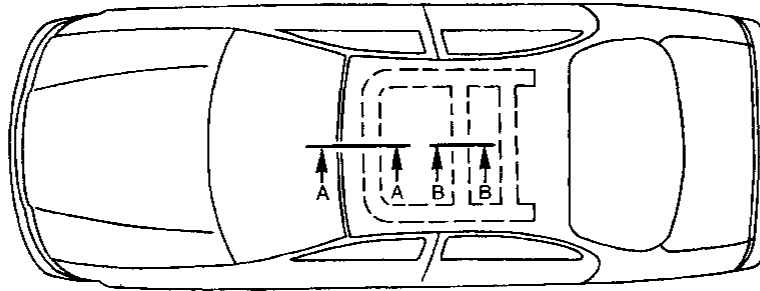

Unit: mm (in)

SBT482

### Gap adjustment

1. Open shade assembly.
2. Tilt glass lid up then remove side trim.
3. Loosen glass lid securing nuts (3 each on left and right sides), then tilt glass lid down.
4. Adjust glass lid from outside of vehicle so it resembles "A-A" as shown in the figure above.
5. Tilt glass lid up and down until it is adjusted to "B-B" as shown in the figure above.
6. After adjusting glass lid, tilt glass lid up and tighten nuts.
7. Tilt glass lid up and down several times to check that it moves smoothly.

### Height difference adjustment

1. Tilt glass lid up and down.
2. Check height difference between roof panel and glass lid to see if it is as "A-A" as shown in the figure above.
3. If necessary, adjust it by using one of following procedures.
  - Adjust by adding or removing adjustment shim(s) between glass lid and link assembly.
  - If glass lid protrudes above roof panel, add shim(s) or plain washer(s) at sunroof mounting bracket or stud bolt locations to adjust sunroof installation as required.

# SUNROOF

## Trouble Diagnoses (Cont'd)

### DRAIN HOSES

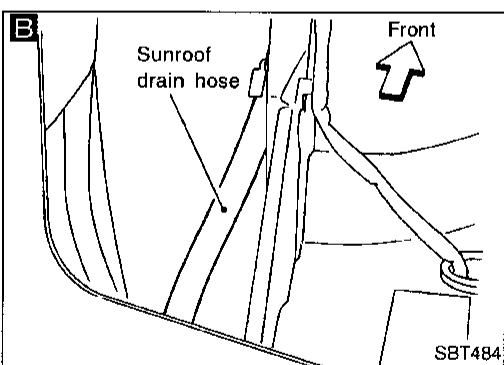
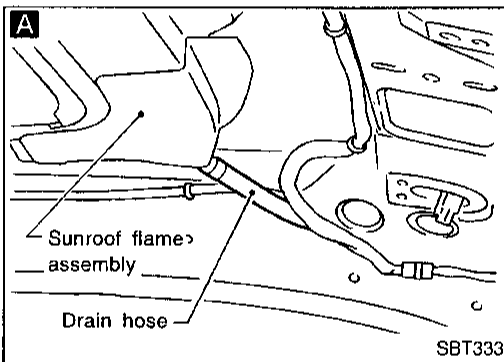
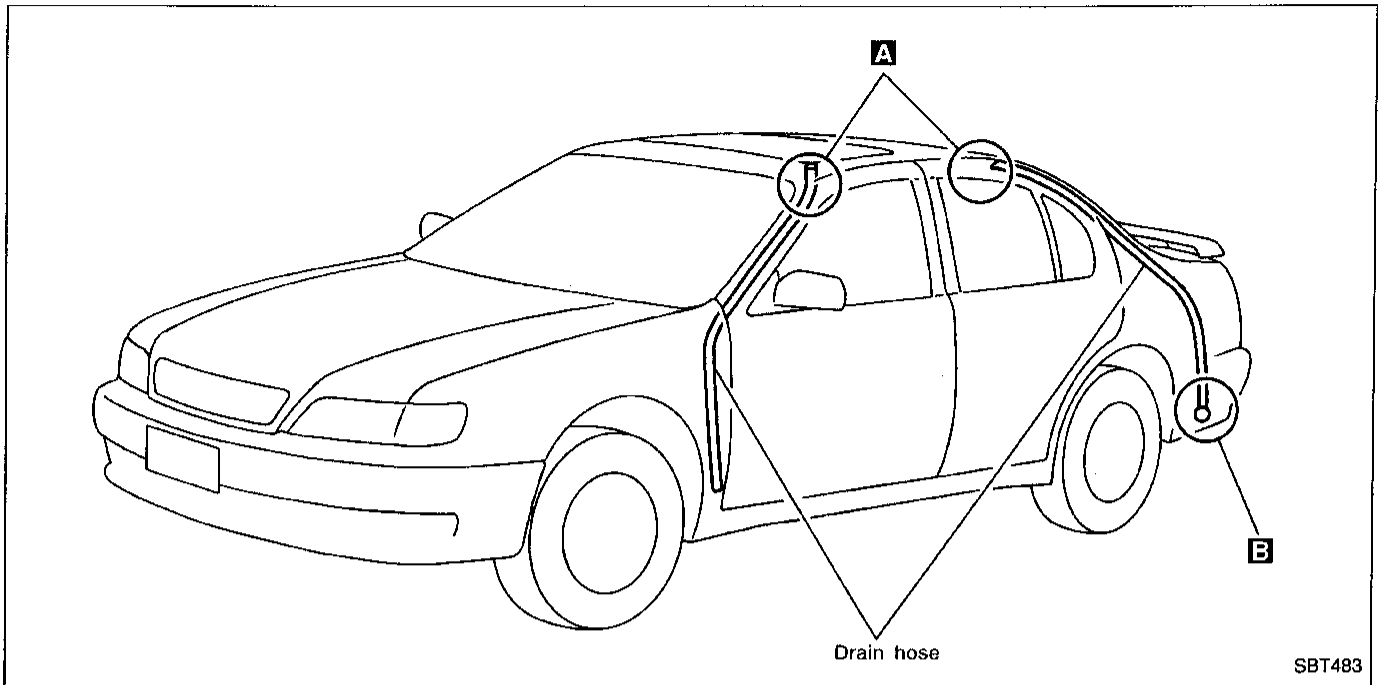

1. Remove headlining to access drain hose connections. (Refer to "REMOVAL — Headlining" in "INTERIOR TRIM", BT-19, for detail.)
2. Check visually for proper connections, damage or deterioration. **A** (The figure shows only the front side.)
3. If leakage occurs around luggage room, remove luggage room side trim and check connecting area. Check for proper connection, damage or tear. **B**
4. Remove drain hoses and check visually for any damage, cracks, or deterioration.
5. Pour water into drain hoses and find damaged portion.
  - If any damaged portion is found at each step, replace the damaged part.

### WEATHERSTRIP

- In the case of leakage around glass lid, close glass lid and pour water over glass lid to find damaged or gap portion.
1. Remove glass lid assembly. (Refer to removal procedures, BT-32, for details.)
  2. Visually check weatherstrip for proper installation. If a gap exists between glass lid and weatherstrip, check for sufficient amount of butyl seal. If required, remove weatherstrip and apply butyl seal.
- Refer to "EXTERIOR" (BT-22), for details.

GI  
 MA  
 EM  
 LC  
 EC  
 FE  
 CL  
 MT  
 AT  
 FA  
 RA  
 BR  
 ST  
 RS  
 BT  
 HA  
 EL  
 IDX  
 1319

## SUNROOF

---

### **Trouble Diagnoses (Cont'd)**

3. Check weatherstrip visually for any damage, deterioration, or flattening.

- If any damage is found, replace weatherstrip.

#### **CAUTION:**

**Do not remove weatherstrip except when replacing, or filling up butyl seal.**

### **LINK AND WIRE ASSEMBLY**

#### **NOTE:**

**Before replacing a suspect part, carefully ensure it is the source of noise being experienced.**

1. Check link to determine if coating film has peeled off to such an extent that substrate is visible. Check also to determine if link is the source of noise. If it is, replace it.
2. Visually check to determine if a sufficient amount of petroleum jelly has been applied to wire or rail groove. If not, add petroleum jelly as required.
3. Check wire for any damage or deterioration. If any damage is found, remove rear guide (refer to removal procedures, BT-32 for details), then replace wire.

# WINDSHIELD AND WINDOWS

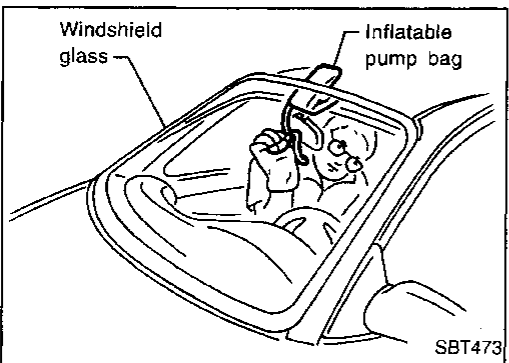
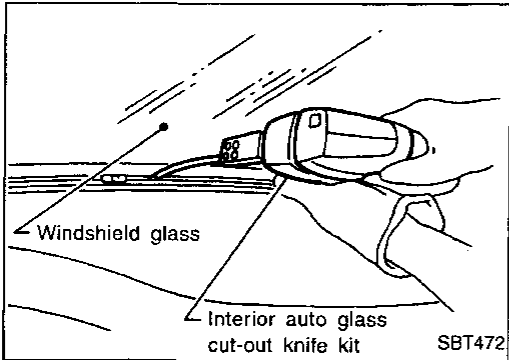
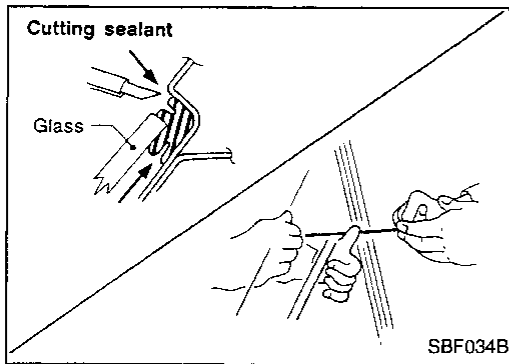

## REMOVAL

After removing moldings, remove glass using piano wire or power cutting tool and an inflatable pump bag.

### WARNING:

When cutting the glass from the vehicle, always wear safety glasses and heavy gloves to help prevent glass splinters from entering your eyes or cutting your hands.

### CAUTION:

- Be careful not to scratch the glass when removing.
- Do not set or stand the glass on its edge. Small chips may develop into cracks.

## INSTALLATION

- Use a genuine Nissan Urethane Adhesive Kit or equivalent and follow the instructions furnished with it.
- While the urethane adhesive is curing, open a door window. This will prevent the glass from being forced out by passenger compartment air pressure when a door is closed.
- The molding must be installed securely so that it is in position and leaves no gap.
- Inform the customer that the vehicle should remain stationary until the urethane adhesive has completely cured (preferably 24 hours). Curing time varies with temperature and humidity.

### WARNING:

- Keep heat and open flames away as primers and adhesive are flammable.
- The materials contained in the kit are harmful if swallowed, and may irritate skin and eyes. Avoid contact with the skin and eyes.
- Use in an open, well ventilated location. Avoid breathing the vapors. They can be harmful if inhaled. If affected by vapor inhalation, immediately move to an area with fresh air.
- Driving the vehicle before the urethane adhesive has completely cured may affect the performance of the windshield in case of an accident.

### CAUTION:

- Do not use an adhesive which is past its usable term. Shelf life of this product is limited to six months after the date of manufacture. Carefully adhere to the expiration or manufacture date printed on the box.
- Keep primers and adhesive in a cool, dry place. Ideally, they should be stored in a refrigerator.
- Do not leave primers or adhesive cartridge unattended with their caps open or off.
- The vehicle should not be driven for at least 24 hours or until the urethane adhesive has completely cured. Curing time varies depending on temperature and humidities. The curing time will increase under higher temperatures and lower humidities.

GI

MA

EM

LC

EC

FE

CL

MT

AT

FA

RA

BR

ST

RS

BT

HA

EL

IDX

## Windshield and Rear Window

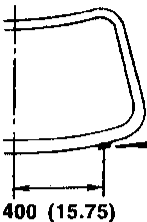
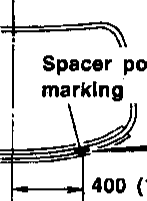
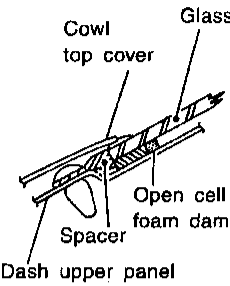
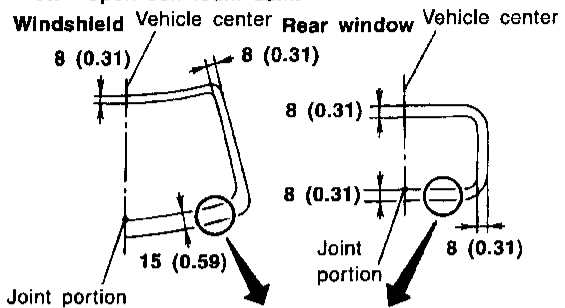
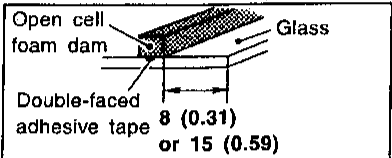
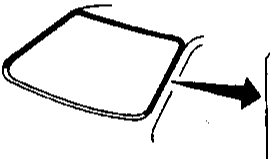
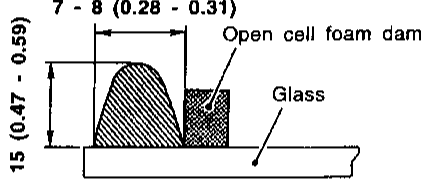
<p><b>Body side</b> Install spacer to panel. <b>Windshield</b></p>  <p>400 (15.75)</p> <p><b>Rear window</b></p>  <p>400 (15.75)</p>		<p><b>Glass side</b> Install open cell foam dam.</p>  <p>8 (0.31) 8 (0.31) 8 (0.31) 8 (0.31) 8 (0.31) 8 (0.31) 15 (0.59)</p> <p>Joint portion Joint portion</p>  <p>Open cell foam dam Glass Double-faced adhesive tape 8 (0.31) or 15 (0.59)</p>
<p><b>Install molding fastener.</b> When installing it, heat body panel and fastener to approx. 30 to 40°C (86 to 104°F).</p>  <p>Upper &amp; side molding fasteners</p>	<p><b>Apply urethane adhesive evenly.</b> <b>Windshield and rear window</b></p>  <p>7 - 8 (0.28 - 0.31) 12 - 15 (0.47 - 0.59)</p> <p>Open cell foam dam Glass</p> <p>Unit: mm (in)</p>	

SBF355HA

### REPAIRING WATER LEAKS FOR WINDSHIELD

Leaks can be repaired without removing and reinstalling glass.

If water is leaking between the urethane adhesive material and body or glass, determine the extent of leakage. This can be done by applying water to the windshield area while pushing glass outward.

To stop the leak, apply primer (if necessary) and then urethane adhesive to the leak point.



# MIRROR

## Door Mirror

### CAUTION:

Be careful not to scratch door rearview mirror body.

★ For Wiring Diagram, refer to "POWER DOOR MIRROR" in EL section.

### REMOVAL — Door mirror

- ① Remove door trim. Refer to "Door Trim" in "INTERIOR TRIM" for details, BT-18.
- ② Remove inner cover front corner of door.
- ③ Disconnect door mirror harness connector.
- ④ Remove door mirror harness clips.
- ⑤ Remove three bolts securing door mirror assembly.
- ⑥ Remove the mirror glass from mirror body. Do not insert screwdriver too far.

SEC. 963

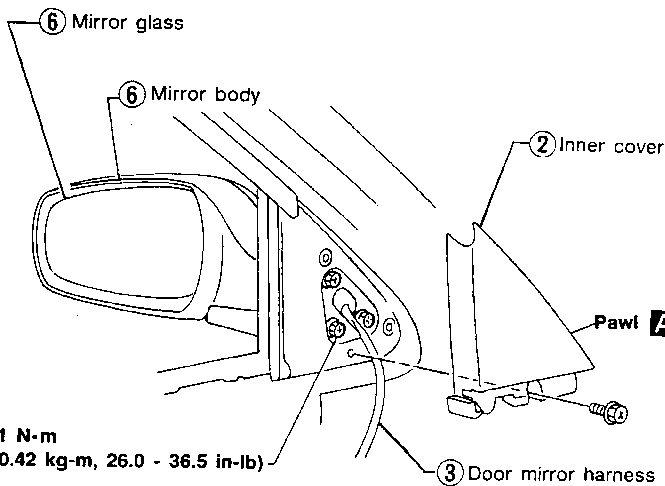

#### Bolts

2.9 - 4.1 N·m  
(0.30 - 0.42 kg-m, 26.0 - 36.5 in-lb)

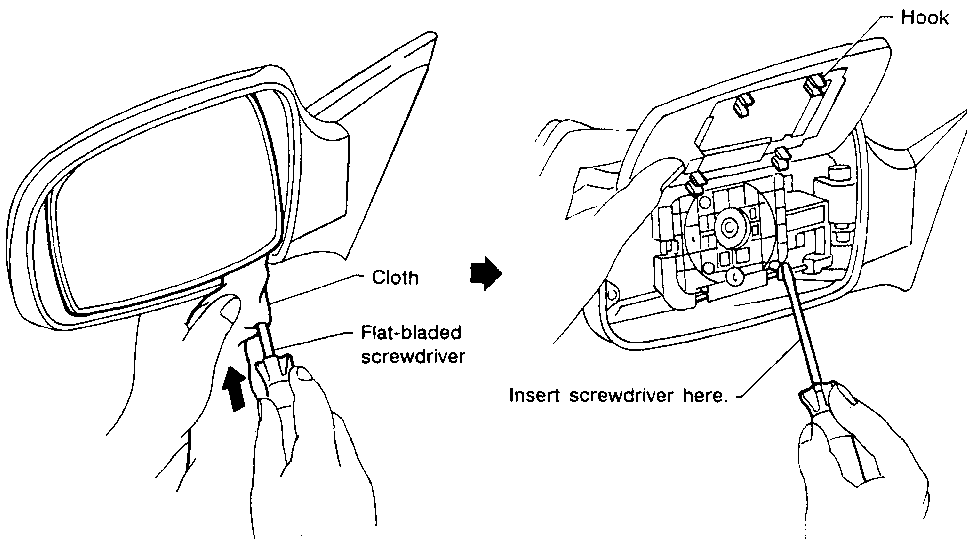
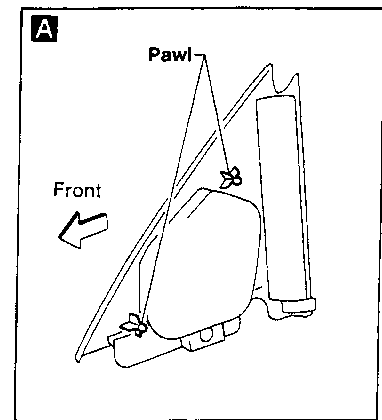

MBT074AA

GI  
MA  
EM  
LC  
EC  
FE  
CL  
MT  
AT  
FA  
RA  
BR  
ST  
RS  
BT  
HA  
EL  
IDX

# BODY ALIGNMENT

- All dimensions indicated in figures are actual ones.
- When using a tracking gauge, adjust both pointers to equal length. Then check the pointers and gauge itself to make sure there is no free play.
- When a measuring tape is used, check to be sure there is no elongation, twisting or bending.
- Measurements should be taken at the center of the mounting holes.
- An asterisk (\*) following the value at the measuring point indicates that the measuring point on the other side is symmetrically the same value.
- The coordinates of the measurement points are the distances measured from the standard line of "X", "Y" and "Z".

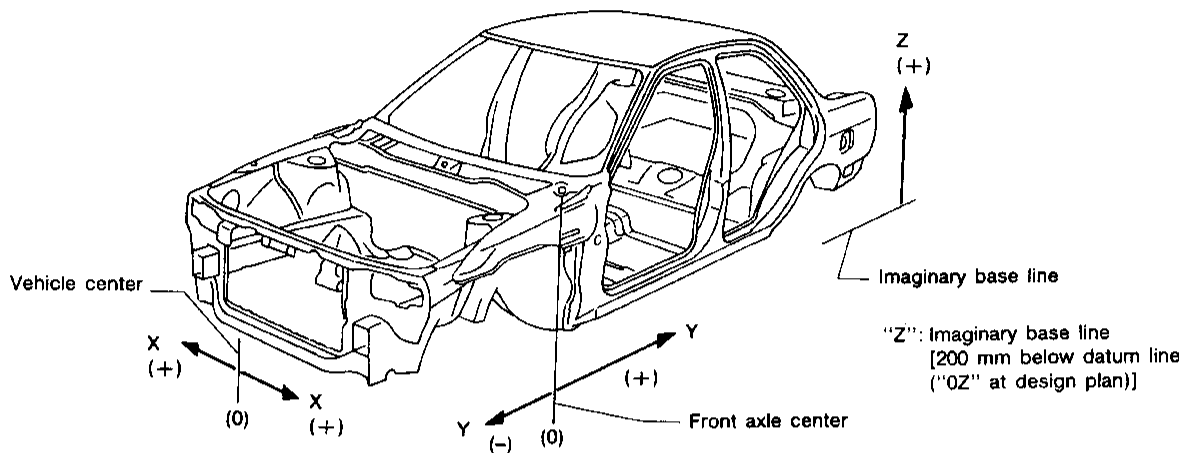

SBF874GB

## Engine Compartment

### MEASUREMENT

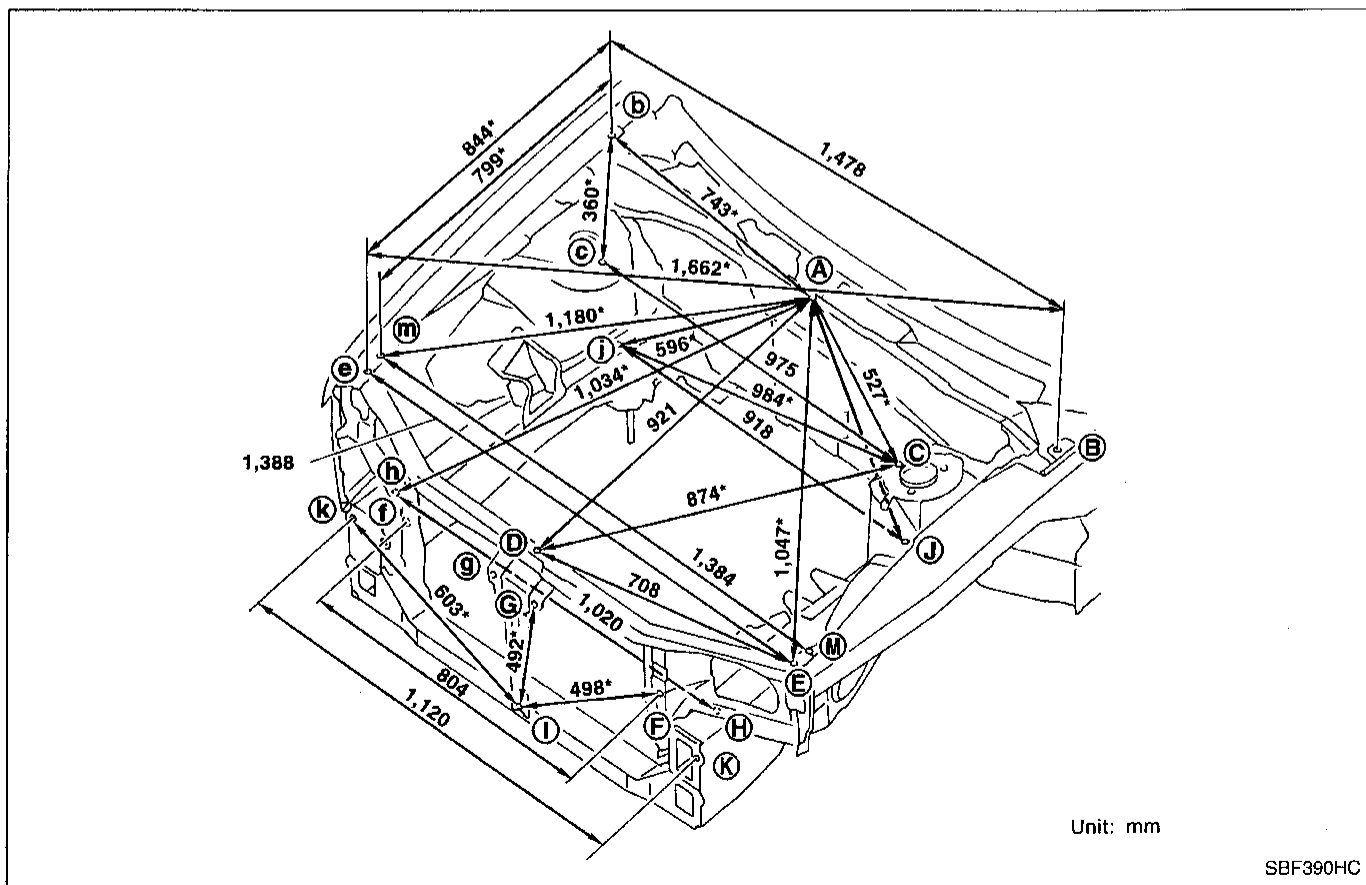

# BODY ALIGNMENT

## Engine Compartment (Cont'd)

### MEASUREMENT POINTS

Unit: mm

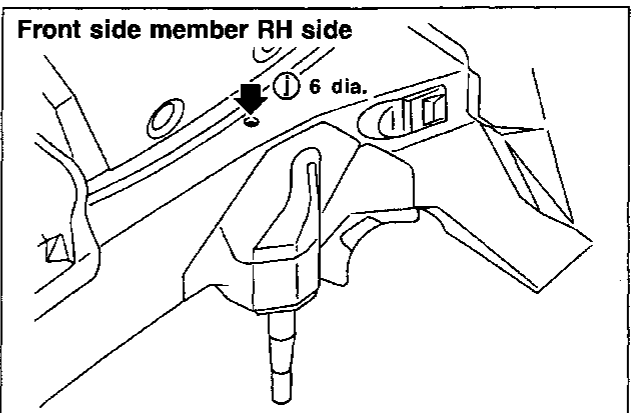
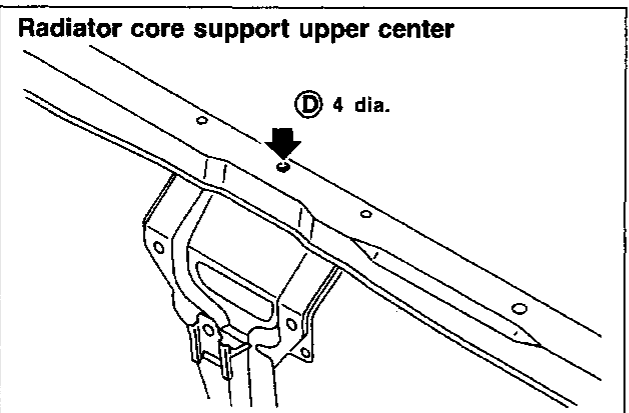
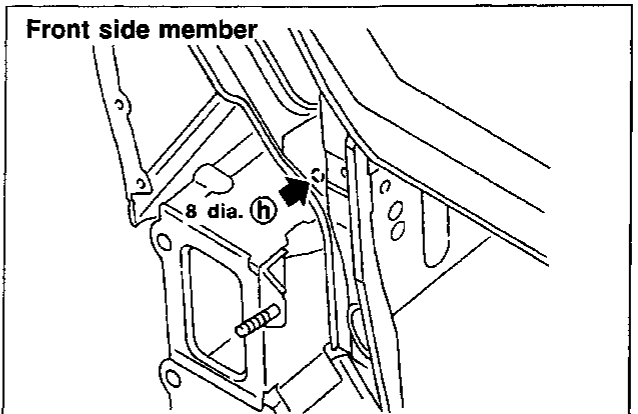
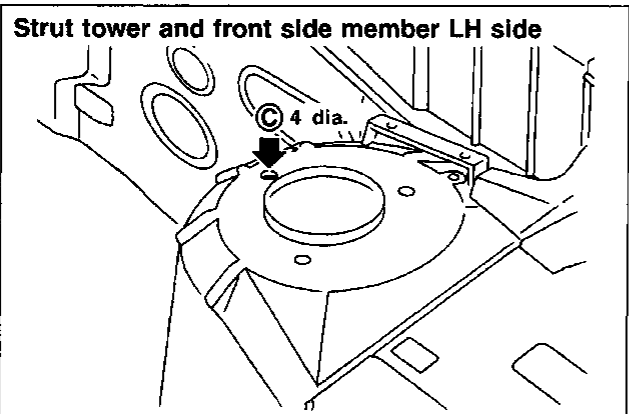
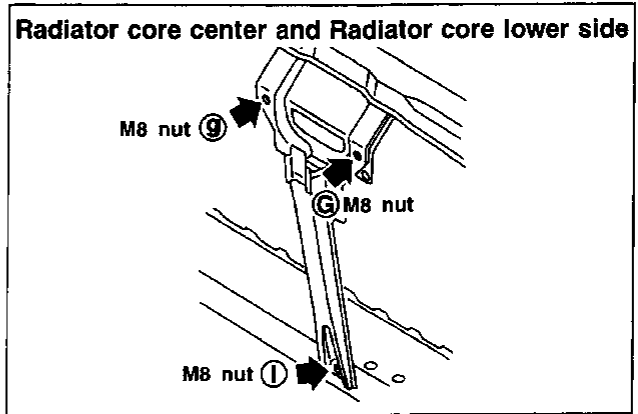
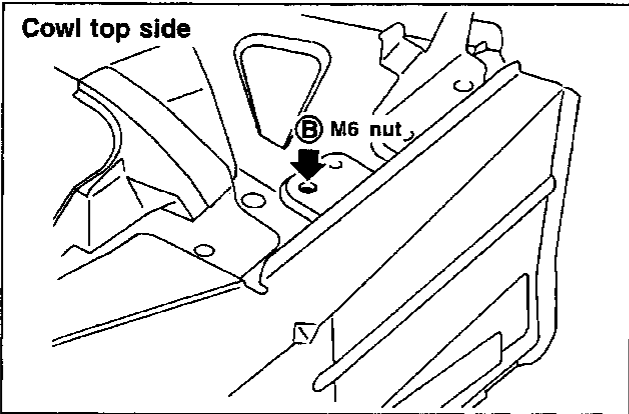
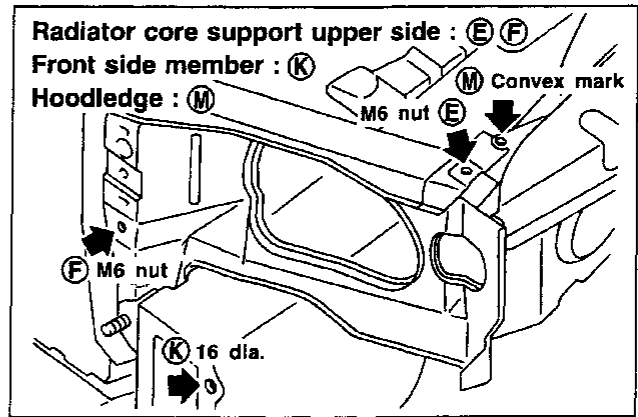
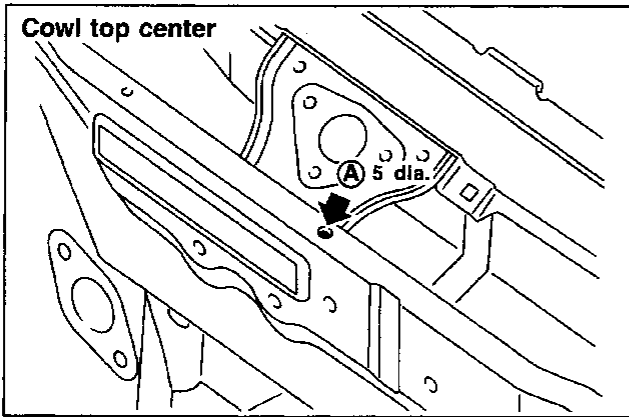

GI

MA

EM

LC

EC

FE

CL

MT

AT

FA

RA

BR

ST

RS

**BT**

HA

EL

IDX

# BODY ALIGNMENT

## Underbody

### MEASUREMENT

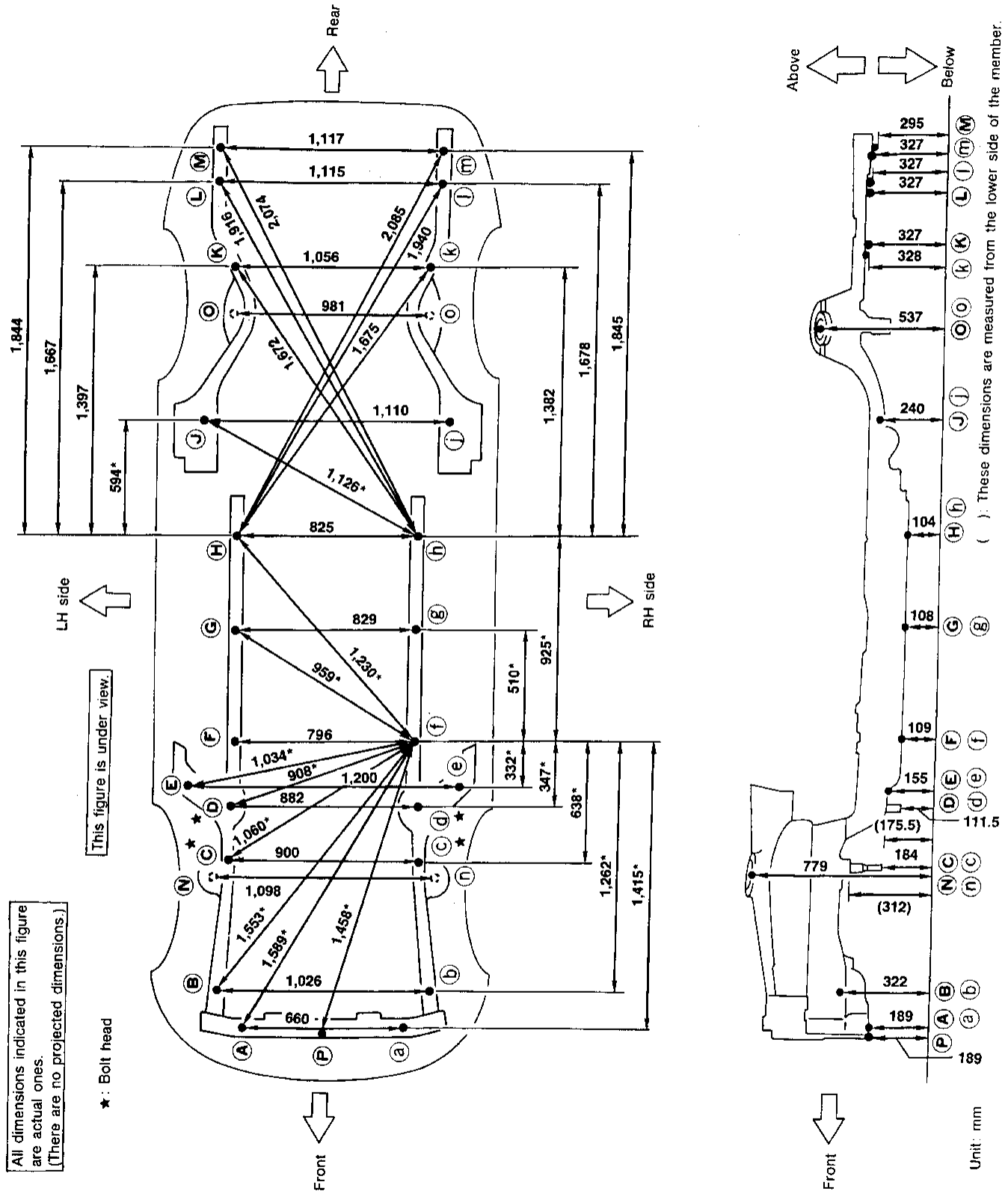

# BODY ALIGNMENT

## Underbody (Cont'd)

### MEASUREMENT POINTS

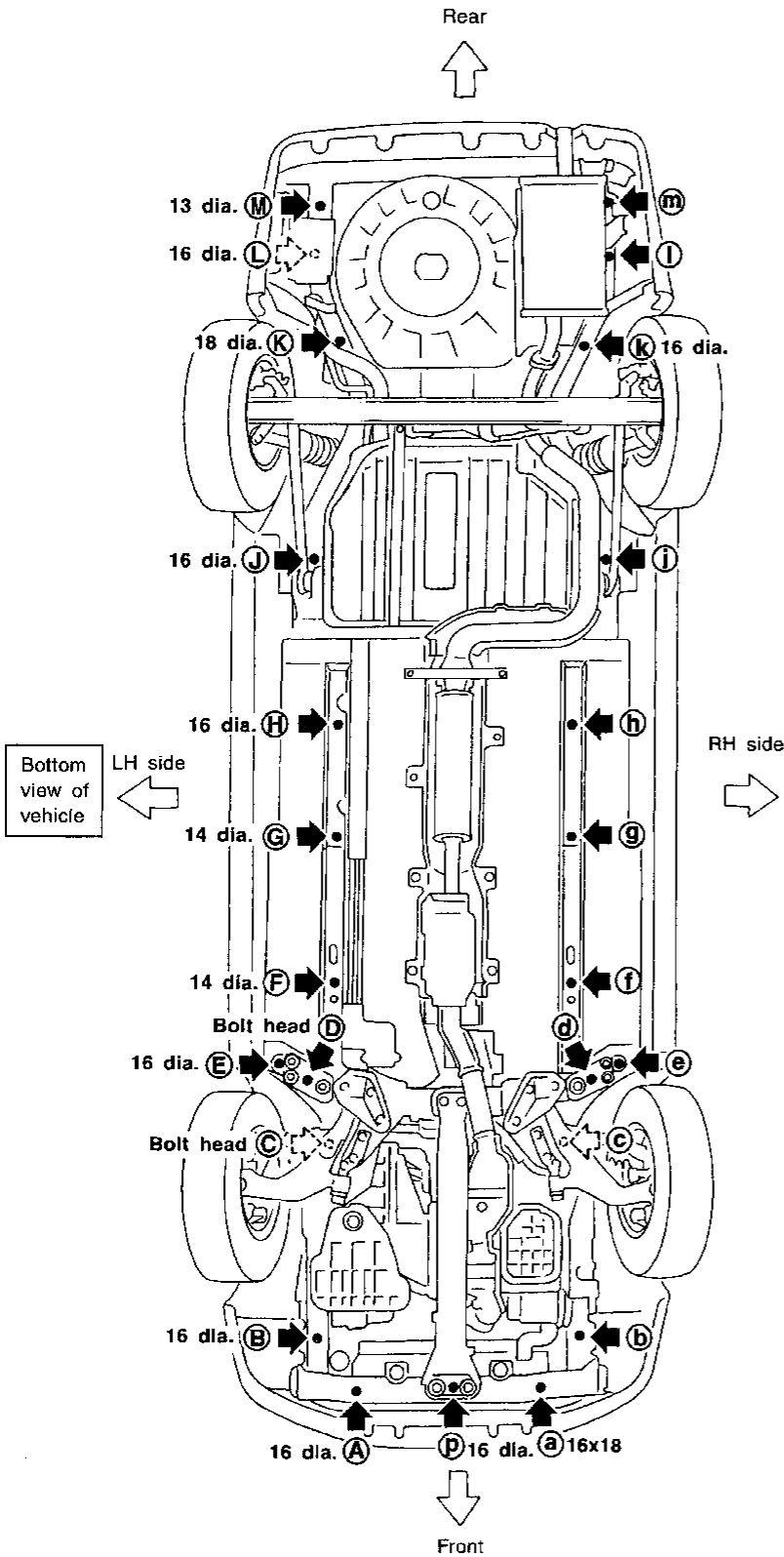

#### Coordinates

<b>(A), (a)</b>	<b>(J), (j)</b>
X : 330	Radius rod
Y : -710	bracket mounting
Z : 188.8	hole
<b>(B), (b)</b>	X : 555
X : 513	Y : 2,185
Y : -540	Z : 239.5
Z : 322	<b>(K)</b>
<b>(C), (c)</b>	X : 512
X : 450	Y : 3,000
Y : 68	Z : 326.6
Z : 184	<b>(k)</b>
<b>(D), (d)</b>	X : 544
X : 441	Y : 2,982
Y : 354	Z : 328.2
Z : 111.5	<b>(L)</b>
<b>(E), (e)</b>	X : 540
X : 600	Y : 3,272
Y : 430	Z : 326.6
Z : 154.9	<b>(I)</b>
<b>(F), (f)</b>	X : 575
X : 398	Y : 3,280
Y : 700	Z : 326.6
Z : 109	<b>(M)</b>
<b>(G), (g)</b>	X : 546
X : 414.5	Y : 3,454
Y : 1,210	Z : 295.4
Z : 108.4	<b>(m)</b>
<b>(H), (h)</b>	X : 570.5
X : 412.5	Y : 3,450
Y : 1,625	Z : 326.6
Z : 104	<b>(P)</b>
	X : 0
	Y : -700.5
	Z : 188.8

#### Front and rear strut tower centers

##### Coordinates:

<b>(N), (n)</b>	
X : 548.8	
Y : 28.7	
Z : 779.3	
<b>(O), (o)</b>	Front: <b>(N), (n)</b> 87 dia.
X : 490.3	Rear: <b>(O), (o)</b> 61.4 dia.
Y : 2,624	
Z : 537.2	

#### Suspension link mounting hole

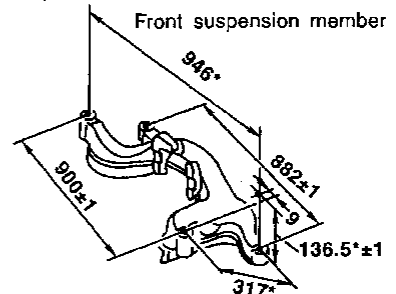

Unit: mm

GI  
MA  
EM  
LC  
EC  
FE  
CL  
MT  
AT  
FA  
RA  
BR  
ST  
RS  
BT  
HA  
EL  
IDX