

STEERING SYSTEM

SECTION **ST**

GI
MA
EM
LC
EC
FE
CL
MT
AT
FA
RA
BR
ST
RS
BT
HA
EL
IDX

CONTENTS

PRECAUTIONS AND PREPARATION2	STEERING WHEEL AND STEERING COLUMN10
Supplemental Restraint System (SRS) "AIR BAG".....2	Removal and Installation10
Precautions for Steering System.....2	Disassembly and Assembly.....12
Special Service Tools3	Inspection.....13
Commercial Service Tools4	POWER STEERING GEAR AND LINKAGE14
NOISE, VIBRATION AND HARSHNESS (NVH)	Removal and Installation14
TROUBLESHOOTING5	Components.....16
NVH Troubleshooting Chart.....5	Disassembly.....17
ON-VEHICLE SERVICE6	Inspection.....17
Checking Steering Wheel Play.....6	Assembly18
Checking Neutral Position on Steering Wheel.....6	Adjustment23
Front Wheel Turning Angle.....6	POWER STEERING OIL PUMP24
Checking Gear Housing Movement6	Pre-disassembly Inspection.....24
Checking and Adjusting Drive Belts7	Disassembly.....25
Checking Fluid Level.....7	Inspection.....25
Checking Fluid Leakage.....7	Assembly26
Bleeding Hydraulic System.....7	SERVICE DATA AND SPECIFICATIONS (SDS)27
Checking Steering Wheel Turning Force8	General Specifications.....27
Checking Hydraulic System.....9	Inspection and Adjustment27

Supplemental Restraint System (SRS) “AIR BAG”

The Supplemental Restraint System “Air Bag”, used along with a seat belt, helps to reduce the risk or severity of injury to the driver and front passenger in a frontal collision. The Supplemental Restraint System consists of air bag modules (located in the center of the steering wheel and on the instrument panel on the passenger side), a diagnosis sensor unit, warning lamp, wiring harness and spiral cable. In addition to the supplemental air bags for a frontal collision, the supplemental side air bag used along with the seat belt help to reduce the risk or severity of injury to the driver and front passenger in a side collision. The supplemental side air bag consists of air bag modules (located in the outer side of front seats), satellite sensor, diagnosis sensor unit (which is one of components of supplemental air bags for a frontal collision), wiring harness, warning lamp (which is one of components of supplemental air bags for a frontal collision). Information necessary to service the system safely is included in the **RS section** in this Service Manual.

WARNING:

- To avoid rendering the SRS inoperative, which could increase the risk of personal injury or death in the event of a collision which would result in air bag inflation, all maintenance must be performed by an authorized INFINITI dealer.
- Improper maintenance, including incorrect removal and installation of the SRS, can lead to personal injury caused by unintentional activation of the system.
- Do not use electrical test equipment on any circuit related to the SRS unless instructed to in this Service Manual. SRS wiring harnesses can be identified with yellow harness protector or yellow insulation tape before the harness connectors.

Precautions for Steering System

- Before disassembly, thoroughly clean the outside of the unit.
- Disassembly should be done in a clean work area. It is important to prevent the internal parts from becoming contaminated by dirt or other foreign matter.
- Place disassembled parts in order, on a parts rack, for easier and proper assembly.
- Use nylon cloths or paper towels to clean the parts; common shop rags can leave lint that might interfere with their operation.
- Before inspection or reassembly, carefully clean all parts with a general purpose, non-flammable solvent.
- Before assembly, apply a coat of recommended ATF* to hydraulic parts. Vaseline may be applied to O-rings and seals. Do not use any grease.
- Replace all gaskets, seals and O-rings. Avoid damaging O-rings, seals and gaskets during installation. Perform functional tests whenever designated.

*: Automatic transmission fluid

PRECAUTIONS AND PREPARATION

Special Service Tools

The actual shapes of Kent-Moore tools may differ from those of special service tools illustrated here.

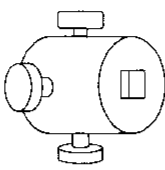
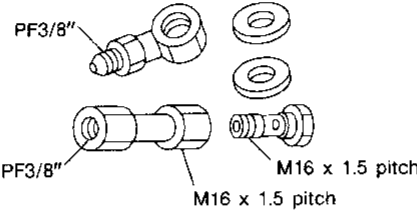
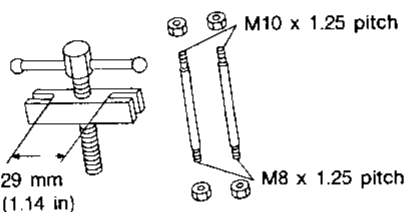
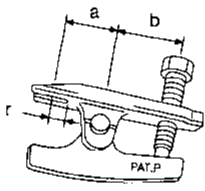
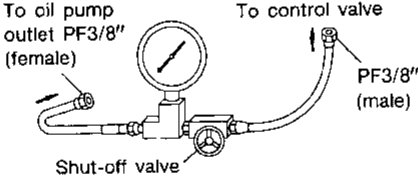
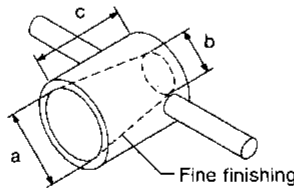
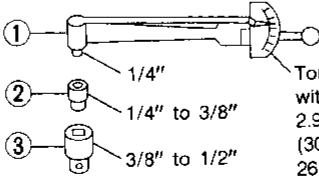
Tool number (Kent-Moore No.) Tool name	Description	
KV48103400 (See J26364) Torque adapter		Measuring pinion rotating torque
	NT236	GI MA EM
KV48102500 (J33914) Pressure gauge adapter		Measuring oil pressure
	NT542	LC EC
ST27180001 (J25726-A) Steering wheel puller		Removing and installing steering wheel
	NT544	FE CL MT
HT72520000 (J25730-A) Ball joint remover		Removing ball joint
	NT546	AT FA
ST27091000 (J26357 and J26357-10) Pressure gauge		Measuring oil pressure
	NT547	RA BR
KV48104400 (—) Rack seal ring reformer		Reforming teflon ring
	NT550	ST RS BT
ST3127S000 (See J25765-A) ① GG91030000 (J25765-A) Torque wrench ② HT62940000 (—) Socket adapter ③ HT62900000 (—) Socket adapter		Measuring turning torque
	NT541	HA EL IDX

PRECAUTIONS AND PREPARATION

Commercial Service Tools

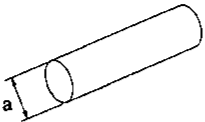
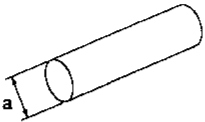
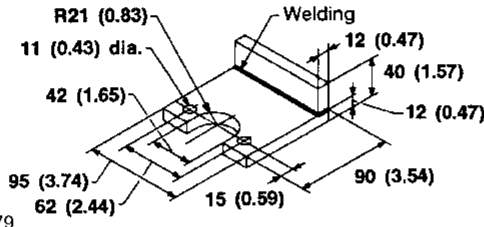
Tool name	Description
Rear oil seal drift	<div style="display: flex; justify-content: space-between; align-items: center;"> <div style="text-align: center;">  <p>NT063</p> </div> <div style="text-align: right;"> <p>Installing rear oil seal</p> <p>a : 28 mm (1.10 in) dia.</p> </div> </div>
Pinion oil seal drift	<div style="display: flex; justify-content: space-between; align-items: center;"> <div style="text-align: center;">  <p>NT063</p> </div> <div style="text-align: right;"> <p>Installing pinion oil seal</p> <p>a : 35 mm (1.38 in) dia.</p> </div> </div>
Oil pump attachment	<div style="display: flex; justify-content: space-between; align-items: center;"> <div style="text-align: center;">  <p>NT179</p> </div> <div style="text-align: right;"> <p>Disassembling and assembling oil pump</p> <p>Unit: mm (in)</p> </div> </div>

NOISE, VIBRATION AND HARSHNESS (NVH) TROUBLESHOOTING

NVH Troubleshooting Chart

Use the chart below to help you find the cause of the symptom. If necessary, repair or replace these parts.

Symptom	STEERING	Possible cause and SUSPECTED PARTS																	Reference page	GI MA EM LC EC FE CL MT AT FA RA BR						
		Fluid level	Air in hydraulic system	Tie-rod ball joint swinging force	Tie-rod ball joint rotating torque	Tie-rod ball joint end play	Steering gear fluid leakage	Steering wheel play	Steering gear lack sliding force	Drive belt looseness	Improper steering wheel	Improper installation or looseness of tilt lock lever	Mounting rubber deterioration	Steering column deformation or damage	Improper installation or looseness of steering column	Steering linkage looseness	DRIVE SHAFT	AXLE AND SUSPENSION			TIRES	ROAD WHEEL	BRAKES			
Noise	STEERING	X	X	X	X	X	X	X	X	X							X	X	X	X	X	ST-7	GI			
											X	X	X				X	X	X	X	X		ST-7	MA		
											X	X	X	X	X		X	X	X				ST-18	EM		
																	X		X	X	X	X		ST-18	LC	
																	X		X	X	X	X		ST-18	EC	
Shake	STEERING																					ST-7	FE			
																							ST-6	CL		
																							ST-8	MT		
																							Refer to MA section.	AT		
																								—	FA	
Vibration	STEERING																					ST-12	RS			
																							ST-6	BT		
																							ST-12	HA		
																							ST-10	EL		
																								ST-14, 16	DX	
Shimmy	STEERING																					NVH in FA section				
																							NVH in FA, RA section			
																								NVH in FA section		
																									NVH in FA section	
																										NVH in BR section
Judder	STEERING																									

X: Applicable

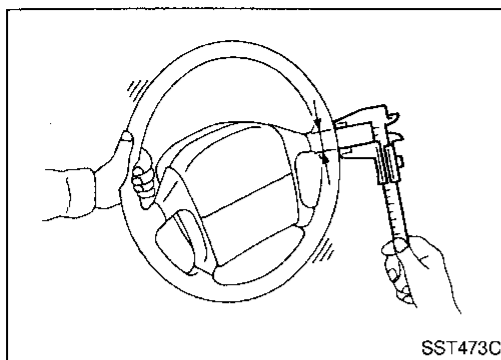

SST473C

Checking Steering Wheel Play

- With wheels in a straight-ahead position, check steering wheel play.

Steering wheel play:

35 mm (1.38 in) or less

- If it is not within specification, check the following for loose or worn components.

Steering gear assembly

Steering column

Front suspension and axle

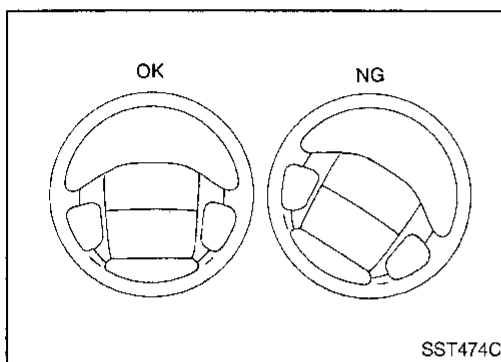

SST474C

Checking Neutral Position on Steering Wheel

Pre-checking

- Make sure that wheel alignment is correct.

Wheel alignment:

Refer to SDS in FA section.

- Verify that the steering gear is centered before removing the steering wheel.

Checking

1. Check that the steering wheel is in the neutral position when driving straight ahead.
2. If it is not in the neutral position, remove the steering wheel and reinstall it correctly.
3. If the neutral position is between two teeth, loosen tie-rod lock nuts. Turn the tie-rods by the same amount in opposite directions on both left and right sides.

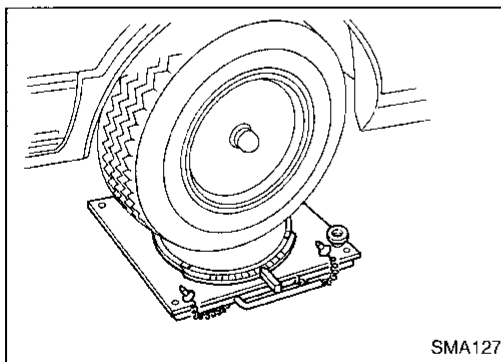

SMA127

Front Wheel Turning Angle

1. Rotate steering wheel all the way right and left; measure turning angle.

Turning angle of full turns:

Refer to SDS in FA section.

2. If it is not within specification, check rack stroke.

Rack stroke "S":

Refer to SDS (ST-27).

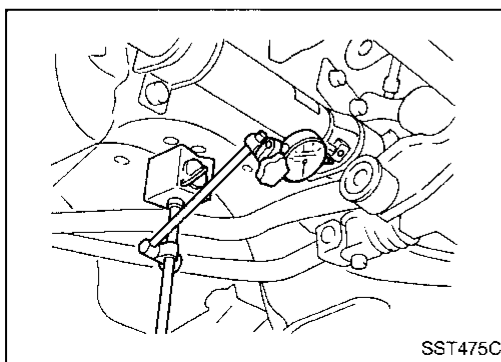

SST475C

Checking Gear Housing Movement

1. Check the movement of steering gear housing during stationary steering on a dry paved surface.

- Apply a force of 49 N (5 kg, 11 lb) to steering wheel to check the gear housing movement.

Turn off ignition key while checking.

Movement of gear housing:

±2 mm (±0.08 in) or less

2. If movement exceeds the limit, replace mount insulator after confirming proper installation of gear housing clamps.

Checking and Adjusting Drive Belts

Refer to "Checking Drive Belts" for "ENGINE MAINTENANCE" in MA section.

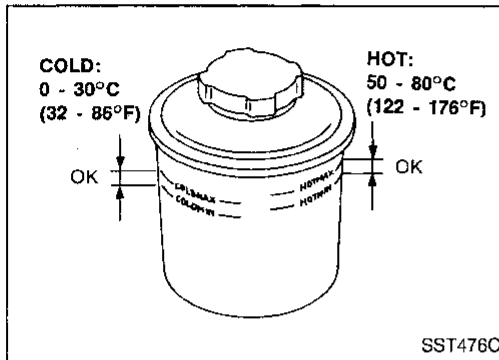

Checking Fluid Level

Check fluid level.

Use the correct range of the tank depending on the fluid temperature. Use the "HOT" range at 50 to 80°C (122 to 176°F), or the "COLD" range at 0 to 30°C (32 to 86°F).

CAUTION:

- Do not overfill.
- Recommended fluid is Automatic Transmission Fluid type DEXRON™III or equivalent.

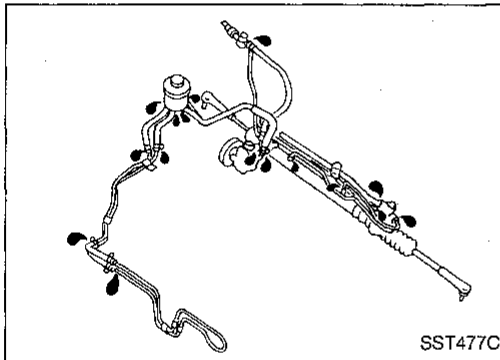

Checking Fluid Leakage

Check the lines for improper attachment and for leaks, cracks, damage, loose connections, chafing and deterioration.

1. Run engine between idle speed and 1,000 rpm.

Make sure temperature of fluid in oil tank rises to 60 to 80°C (140 to 176°F).

2. Turn steering wheel right-to-left several times.
3. Hold steering wheel at each "lock" position for five seconds and carefully check for fluid leakage.

CAUTION:

Do not hold the steering wheel in a locked position for more than 15 seconds.

4. If fluid leakage at connectors is noticed, loosen flare nut and then retighten.

Do not overtighten connector as this can damage O-ring, washer and connector.

5. Check rack boots for accumulation of power steering fluid.

Bleeding Hydraulic System

1. Raise front end of vehicle until wheels are clear of the ground.
2. Add fluid into oil tank to specified level. Then quickly turn steering wheel fully to right and left and lightly touch steering stoppers.

Repeat steering wheel operation until fluid level no longer decreases.

3. Start engine.
Repeat step 2 above.

Bleeding Hydraulic System (Cont'd)

- Incomplete air bleeding will cause the following to occur. When this happens, bleed air again.
 - a. Air bubbles in reservoir tank
 - b. Clicking noise in oil pump
 - c. Excessive buzzing in oil pump

Fluid noise may occur in the valve or oil pump. This is common when the vehicle is stationary or while turning steering wheel slowly. This does not affect performance or durability of the system.

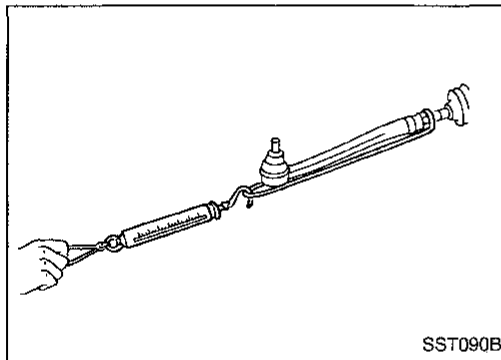
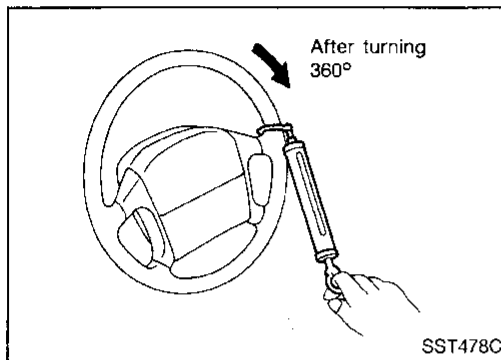

Checking Steering Wheel Turning Force

1. Park vehicle on a level, dry surface and set parking brake.
2. Start engine.
3. Bring power steering fluid up to adequate operating temperature. [Make sure temperature of fluid is approximately 60 to 80°C (140 to 176°F).]

Tires need to be inflated to normal pressure.

4. Check steering wheel turning force when steering wheel has been turned 360° from the neutral position.

Steering wheel turning force:

39 N (4 kg, 9 lb) or less

5. If steering wheel turning force is out of specification, check rack sliding force.
 - a. Disconnect steering column lower joint and knuckle arms from the gear.
 - b. Start and run engine at idle to make sure steering fluid has reached normal operating temperature.
 - c. Pull tie-rod slowly to move it from neutral position to ± 11.5 mm (± 0.453 in) at speed of 3.5 mm (0.138 in)/s. Check that rack sliding force is within specification.

Rack sliding force:

186 - 284 N (19 - 29 kg, 42 - 64 lb)

- d. Check sliding force outside above range.

Rack sliding force:

Not more than 294 N (30 kg, 66 lb)

6. If rack sliding force is not within specification, overhaul steering gear assembly.

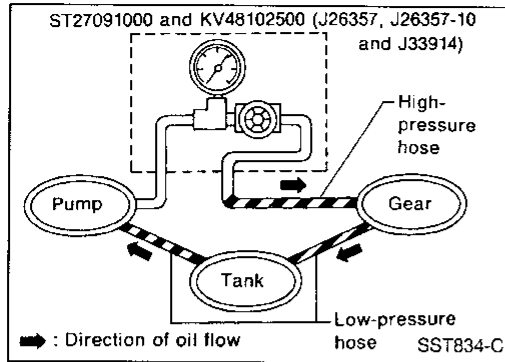

Checking Hydraulic System

- Before starting, check belt tension, driving pulley and tire pressure.
1. Set Tool. Open shut-off valve. Then bleed air. Refer to "Bleeding Hydraulic System", ST-7.
 2. Run engine at idle speed or 1,000 rpm.

Make sure fluid temperature in reservoir tank rises to 60 to 80°C (140 to 176°F).

WARNING:

Warm up engine with shut-off valve fully opened. If engine is started with shut-off valve closed, fluid pressure in the power steering pump increases to maximum. This will raise fluid temperature abnormally.

3. Check pressure with steering wheel fully turned to left and right positions with engine idling at 1,000 rpm.

CAUTION:

Do not hold the steering wheel in a locked position for more than 15 seconds.

**Power steering pump maximum operating pressure:
8,140 - 8,728 kPa (83 - 89 kg/cm², 1,180 - 1,266 psi)**

- If pressure reaches maximum operating pressure, system is OK.
 - If pressure increases above maximum operating pressure, check power steering pump flow control valve. Refer to ST-24.
4. If power steering pressure is below the maximum operating pressure, slowly close shut-off valve and check pressure again.

CAUTION:

Do not close shut-off valve for more than 15 seconds.

- If pressure increases to maximum operating pressure, gear is damaged. Refer to "Removal and Installation", ST-14.
 - If pressure remains below maximum operating pressure, pump is damaged. Refer to "Disassembly", ST-25.
5. After checking hydraulic system, remove Tool and add fluid as necessary. Then completely bleed air out of system. Refer to ST-7.

GI

MA

EM

LC

EC

FE

CL

MT

AT

FA

RA

BR

ST

RS

BT

HA

EL

IDX

STEERING WHEEL AND STEERING COLUMN

Removal and Installation

SEC. 484-488

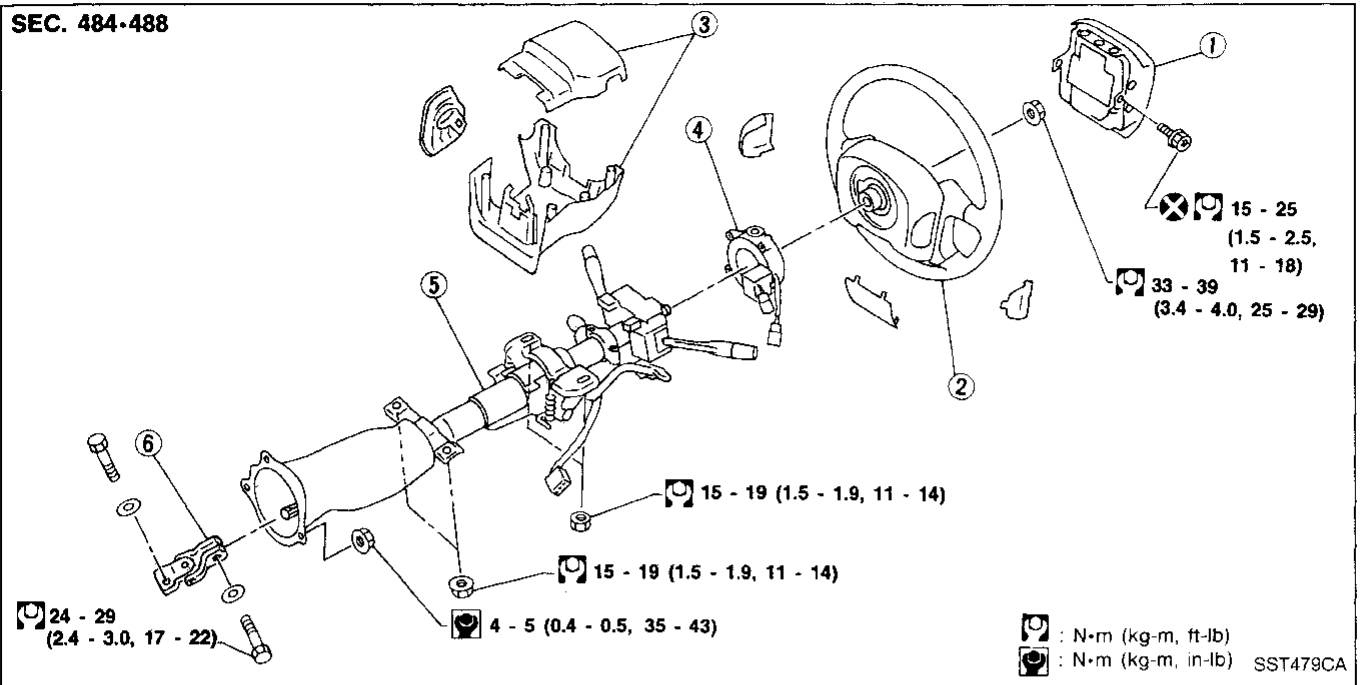

- ① Air bag module
- ② Steering wheel

- ③ Column cover
- ④ Spiral cable

- ⑤ Steering column assembly
- ⑥ Lower joint

CAUTION:

- The rotation of the spiral cable (SRS "Air bag" component part) is limited. If the steering gear must be removed, set the front wheels in the straight-ahead direction. Do not rotate the steering column while the steering gear is removed.
- Remove the steering wheel before removing the steering lower joint to avoid damaging the SRS spiral cable.

STEERING WHEEL

- Remove air bag module and spiral cable. Refer to "Removal — Air Bag Module and Spiral Cable", "SUPPLEMENTAL RESTRAINT SYSTEM" in RS section.

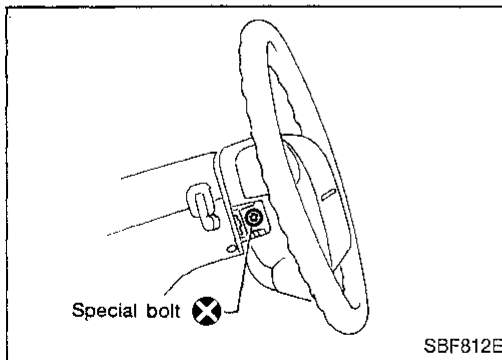

STEERING WHEEL AND STEERING COLUMN

Removal and Installation (Cont'd)

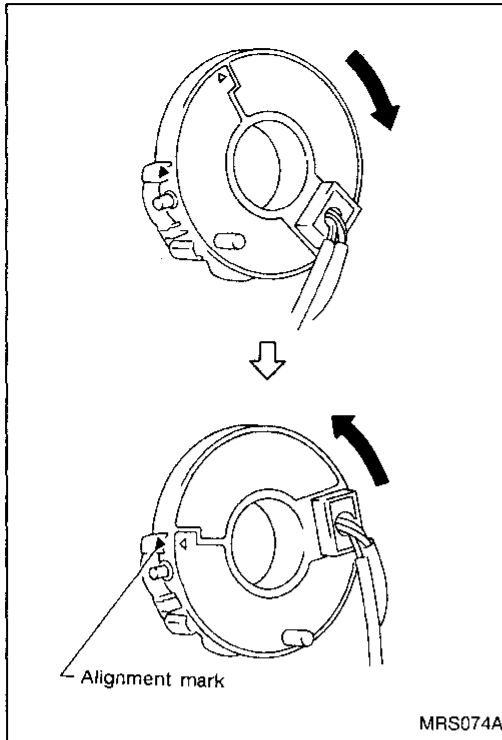

- Align spiral cable correctly when installing steering wheel.
 - a. Set the front wheels in the straight-ahead position.
 - b. Make sure that the spiral cable is in the neutral position. The neutral position is detected by turning left 2.5 revolutions from the right end position. Align the two marks (∇).

CAUTION:

The spiral cable may snap due to steering operation if the cable is installed in an improper position. Also, with the steering linkage disconnected, the cable may snap by turning the steering wheel beyond the limited number of turns. (The spiral cable can be turned up to 2.5 turns from the neutral position to both the right and left.)

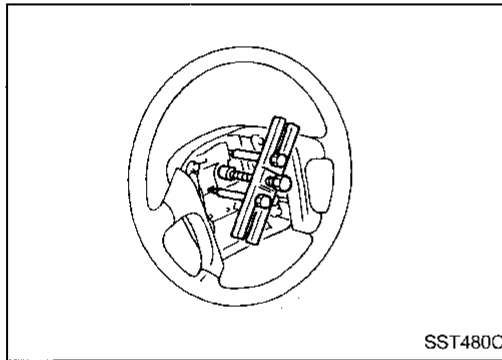

- Remove steering wheel with Tool.

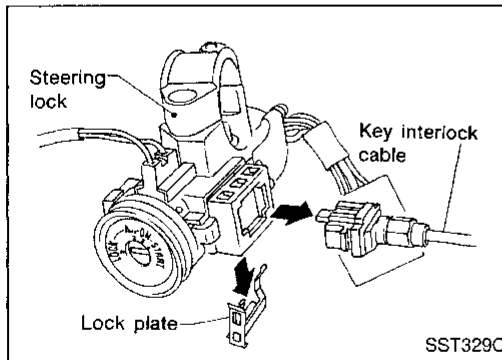

STEERING COLUMN

- Remove key interlock cable (A/T models).

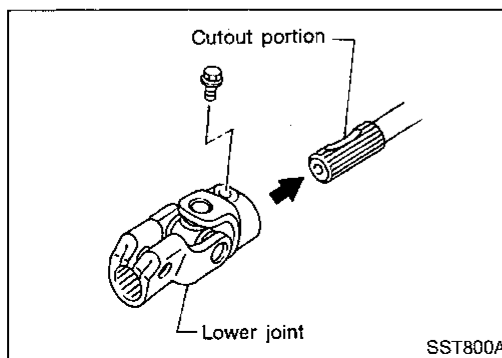

- When installing steering column, fingertighten all lower bracket and clamp retaining bolts; then tighten them securely. Do not apply undue stress to steering column.
- When attaching coupling joint, be sure tightening bolt faces cutout portion.

STEERING WHEEL AND STEERING COLUMN

Removal and Installation (Cont'd)

- Align slit of lower joint with projection on dust cover. Insert joint until surface A contacts surface B.

CAUTION:

After installation, turn steering wheel to make sure it moves smoothly. Ensure the number of turns are the same from the straight forward position to left and right locks. Be sure that the steering wheel is in a neutral position when driving straight ahead.

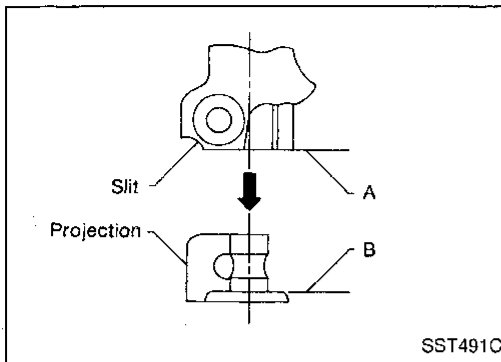

Disassembly and Assembly

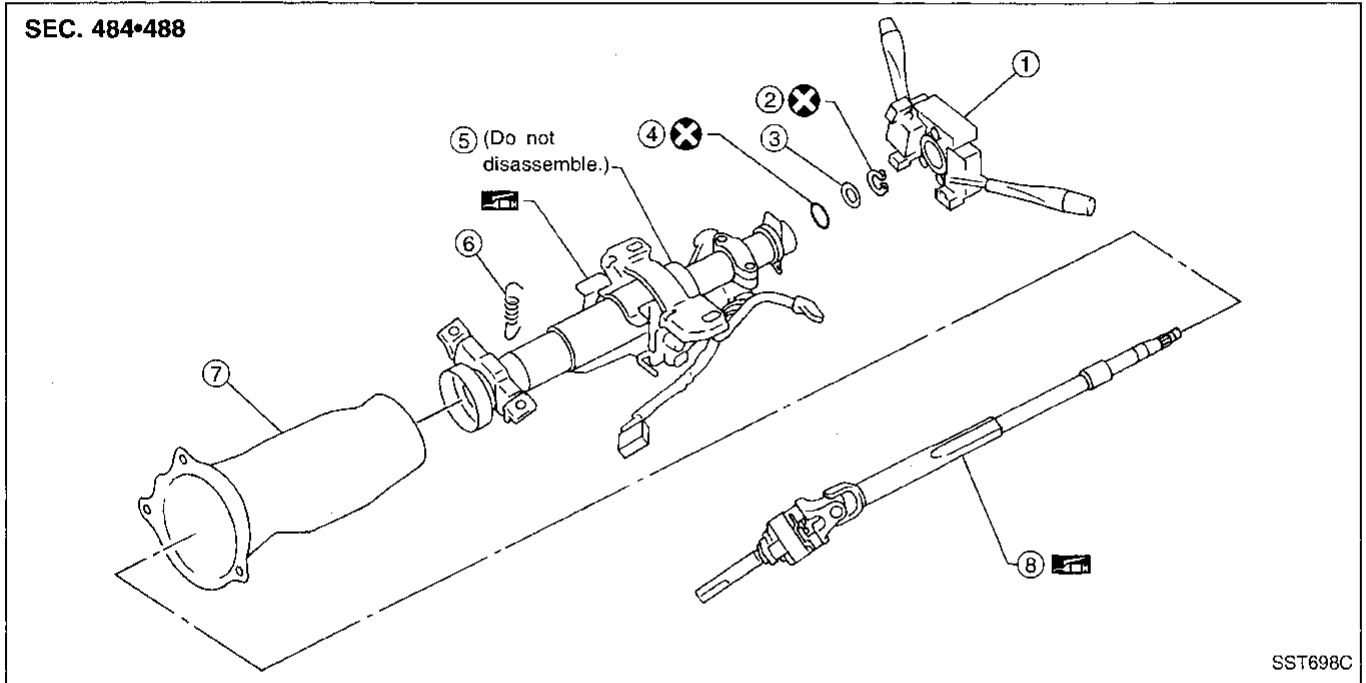

- | | | |
|----------------------|------------------------|-------------------------------|
| ① Combination switch | ④ O-ring | ⑦ Steering column lower cover |
| ② Snap ring | ⑤ Jacket tube assembly | ⑧ Column shaft assembly |
| ③ Washer | ⑥ Spring | |

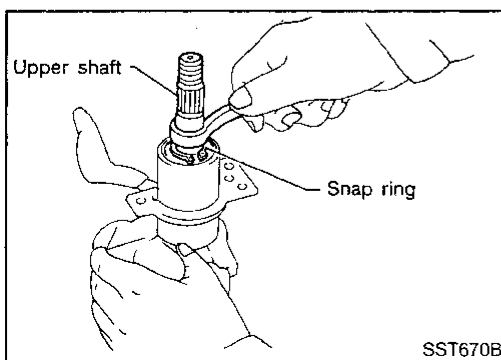

- When disassembling and assembling, unlock steering lock with key.
- Remove combination switch.
- Ensure that rounded surface of snap ring faces toward bearing when snap ring is installed.
- Install snap ring on upper shaft with a suitable tool.

STEERING WHEEL AND STEERING COLUMN

Disassembly and Assembly (Cont'd)

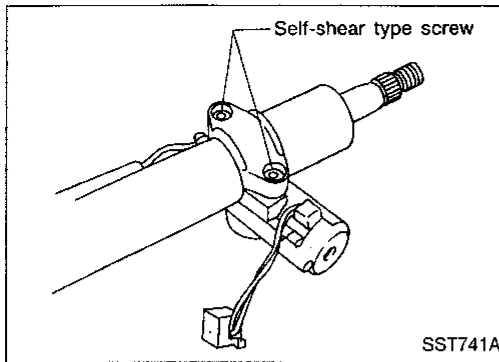

- Steering lock
- a. Break self-shear type screws with a drill or other appropriate tool.

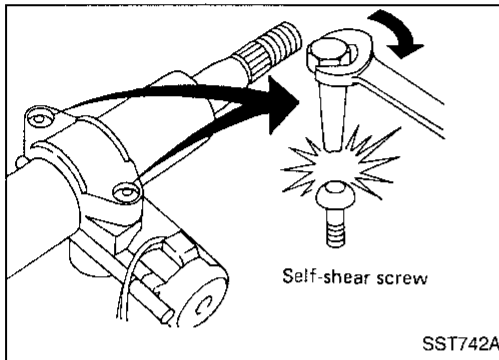

- b. Install new self-shear type screws and then cut off self-shear type screw heads.

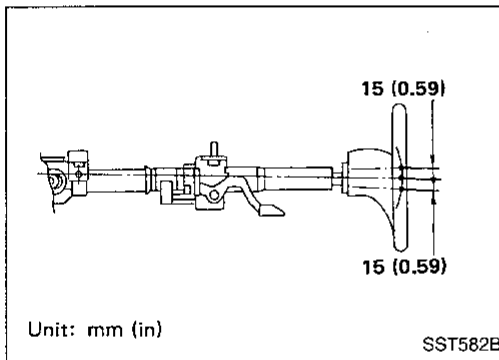

Tilt mechanism

- After installing steering column, check tilt mechanism operation.

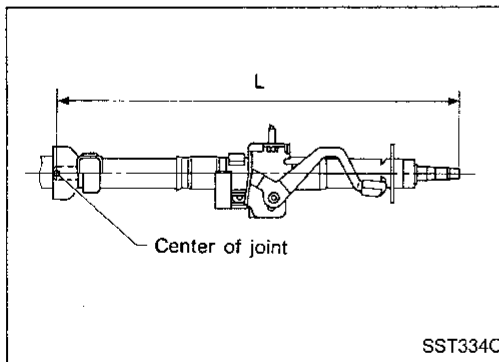

Inspection

- When steering wheel does not turn smoothly, check the steering column as follows and replace damaged parts.
- a. Check column bearings for damage or unevenness. Lubricate with recommended multi-purpose grease or replace steering column as an assembly, if necessary.
- b. Check jacket tube for deformation or breakage. Replace if necessary.

- When the vehicle comes into a light collision, check length "L".

Column length "L":

525.9 - 528.1 mm (20.70 - 20.79 in)

If out of the specifications, replace steering column as an assembly.

GI
MA
EM
LC
EC
FE
CL
MT
AT
FA
RA
BR
ST
RS
BT
HA
EL
IDX

Removal and Installation

SEC. 492

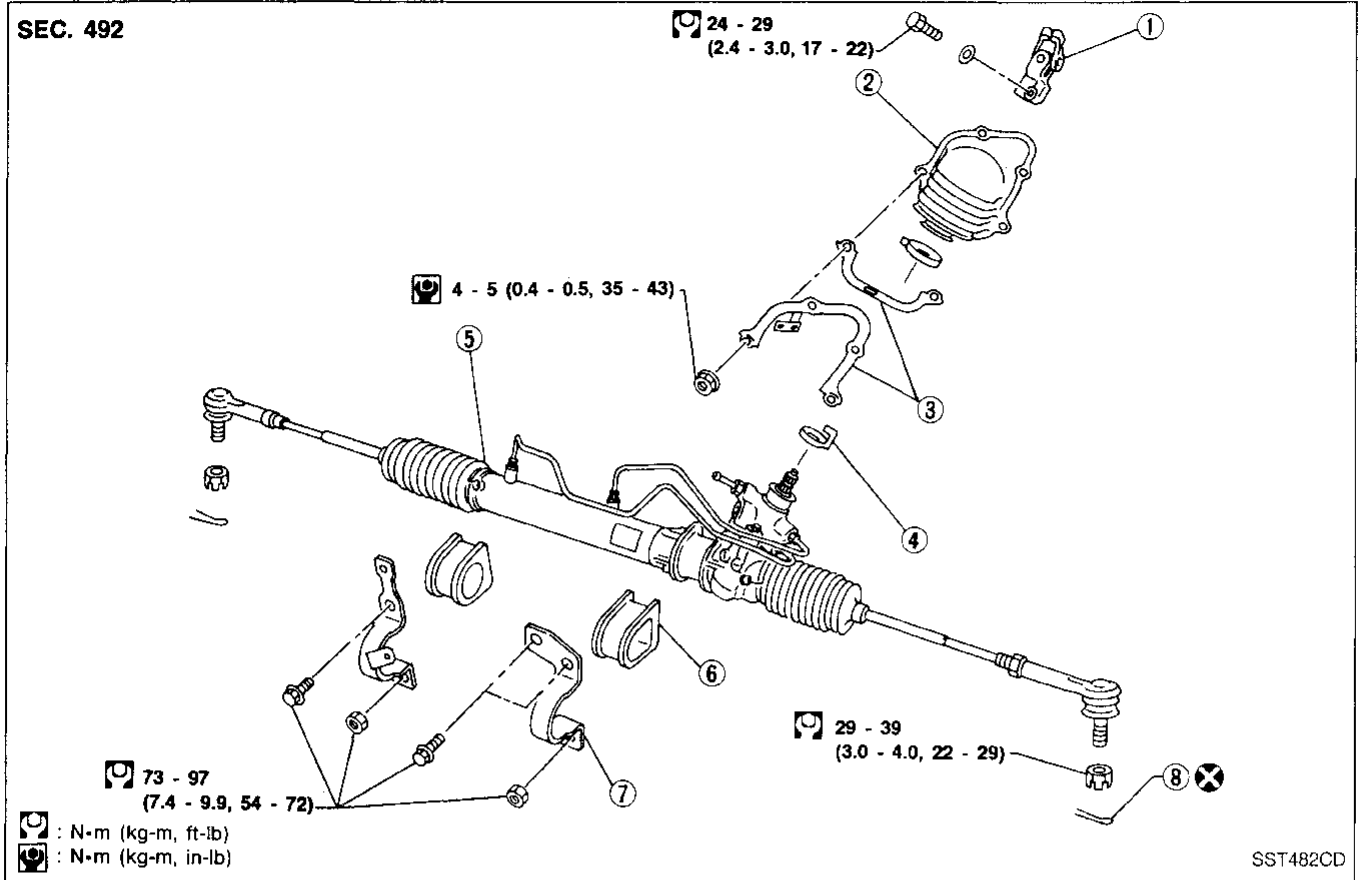

- | | | |
|---------------------|-----------------------------|---------------------------------|
| ① Lower joint | ④ Rear cover cap | ⑦ Gear housing mounting bracket |
| ② Hole cover | ⑤ Gear and linkage assembly | ⑧ Cotter pin |
| ③ Insulator bracket | ⑥ Rack mounting insulator | |

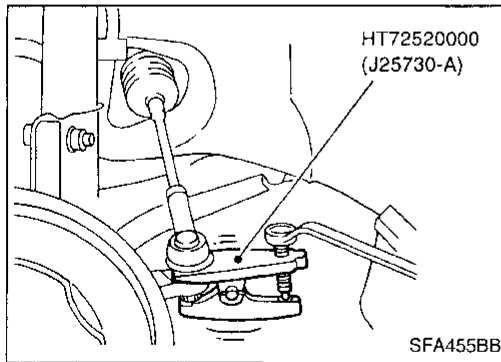

CAUTION:

- The rotation of the spiral cable (SRS "Air bag" component part) is limited. If the steering gear must be removed, set the front wheels in the straight-ahead direction. Do not rotate the steering column while the steering gear is removed.
 - Remove the steering wheel before removing the steering lower joint to avoid damaging the SRS spiral cable.
 - Detach tie-rod outer sockets from knuckle arms with Tool.
 - When disconnecting steering shaft lower joint, follow the procedure shown below.
- 1) Remove carbon canister, engine mounting center member and front suspension stabilizer bar. Refer to FA section.
 - 2) Remove nuts for fitting the hole cover.
 - 3) Disconnect the lower joint while shifting the hole cover.

POWER STEERING GEAR AND LINKAGE

Removal and Installation (Cont'd)

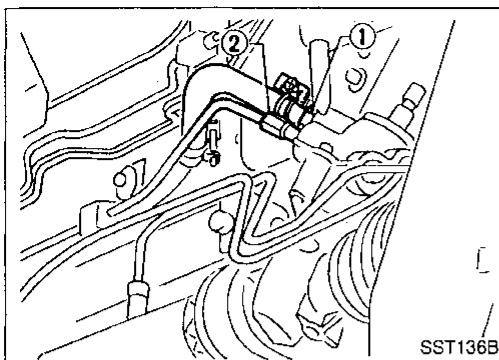

- Install pipe connector.
- Observe specified tightening torque when tightening high-pressure and low-pressure pipe connectors. Excessive tightening will damage threads of connector or O-ring.

Connector tightening torque:

- ① Low-pressure side
27 - 39 N·m (2.8 - 4.0 kg-m, 20 - 29 ft-lb)
- ② High-pressure side
15 - 25 N·m (1.5 - 2.5 kg-m, 11 - 18 ft-lb)

- The O-ring in low-pressure pipe connector is larger than that in high-pressure connector. Take care to install the proper O-ring.

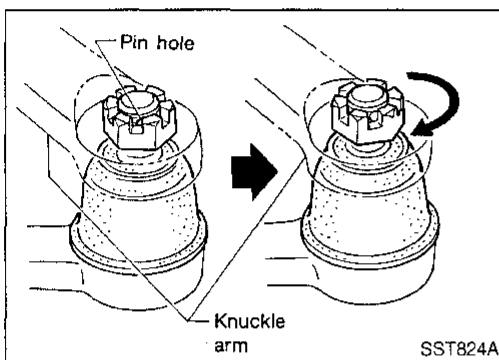

- Initially, tighten nut on tie-rod outer socket and knuckle arm to 29 to 39 N·m (3 to 4 kg-m, 22 to 29 ft-lb). Then tighten further to align nut groove with first pin hole so that cotter pin can be installed.

CAUTION:

Tightening torque must not exceed 49 N·m (5 kg-m, 36 ft-lb).

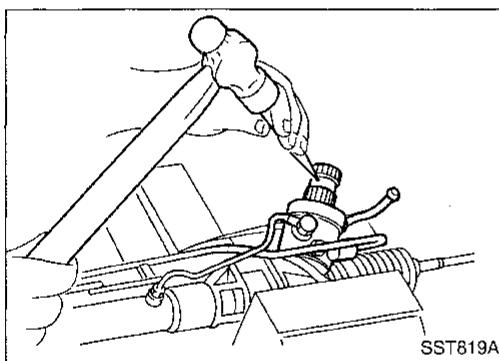

- Before removing lower joint from gear, set gear in neutral (wheels in straight-ahead position). After removing lower joint, put matching mark on pinion shaft and pinion housing to record neutral position.
- To install, set left and right dust boots to equal deflection. Attach lower joint by aligning matching marks of pinion shaft and pinion housing.

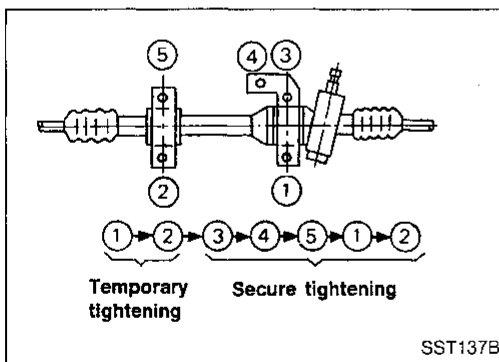

- Tighten gear housing mounting bracket bolts in the order shown.

GI

MA

EM

LC

EC

FE

CL

MT

AT

FA

RA

BR

ST

RS

BT

HA

EL

IDX

POWER STEERING GEAR AND LINKAGE

Components

SEC. 492

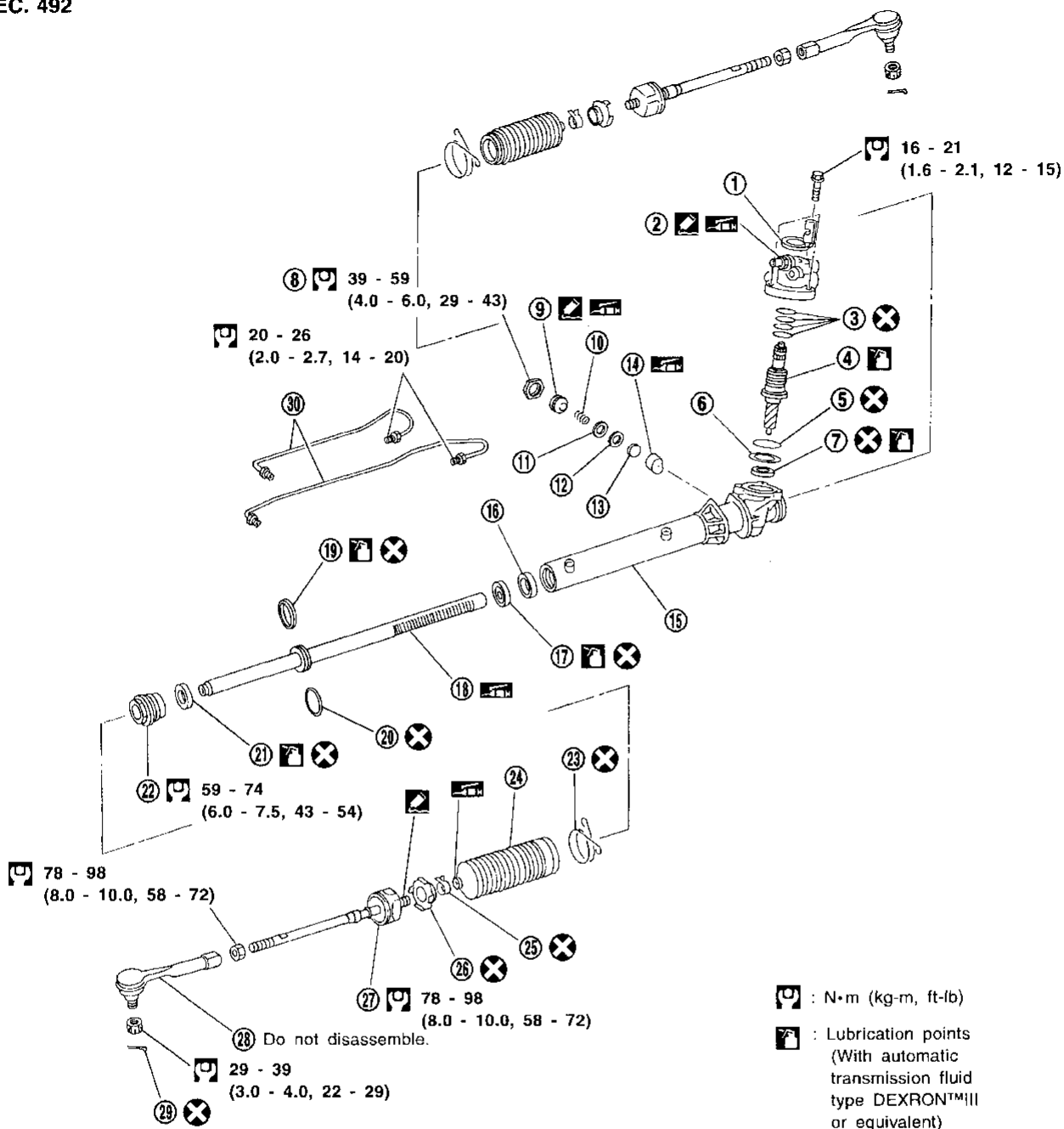

SST483CC

- | | | |
|-------------------------|------------------|------------------------|
| ① Rear cover cap | ⑩ Spring disc | ⑳ Rack oil seal |
| ② Rear housing assembly | ⑪ Washer | ㉑ End cover assembly |
| ③ Pinion seal ring | ⑫ Spring seat | ㉒ Boot clamp |
| ④ Pinion assembly | ⑬ Retainer | ㉓ Dust boot |
| ⑤ O-ring | ⑭ Gear housing | ㉔ Boot band |
| ⑥ Shim | ⑮ Center bushing | ㉕ Lock plate |
| ⑦ Pinion oil seal | ⑯ Rack oil seal | ㉖ Tie-rod inner socket |
| ⑧ Lock nut | ⑰ Rack assembly | ㉗ Tie-rod outer socket |
| ⑨ Adjusting screw | ⑱ Rack seal ring | ㉘ Cotter pin |
| ⑩ Spring | ㉚ O-ring | ㉙ Gear housing tube |

ST-16

POWER STEERING GEAR AND LINKAGE

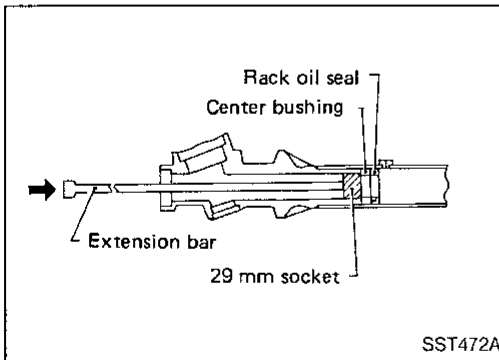
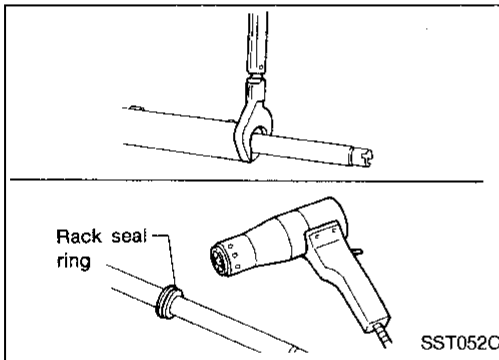
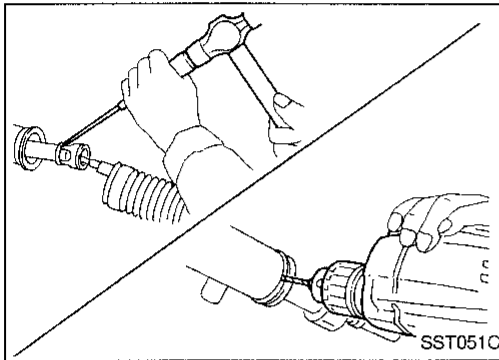
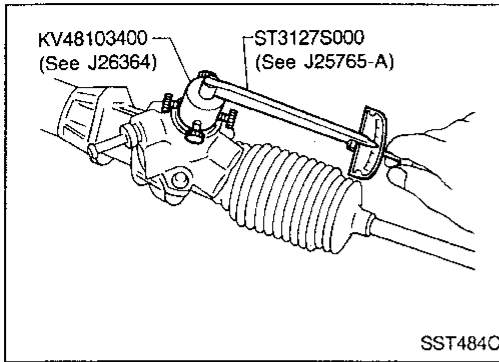

Disassembly

1. Prior to disassembling, measure pinion rotating torque. Record the pinion rotating torque as a reference.
 - Before measuring, disconnect gear housing tube and drain fluid.
 - Use soft jaws when holding steering gear housing. Handle gear housing carefully, as it is made of aluminum. Do not grip cylinder in a vise.
2. Remove pinion gear.

Be careful not to damage pinion gear when removing pinion seal ring.

3. Remove tie-rod outer sockets and boots.
4. Loosen tie-rod inner socket by prying up staked portion, and remove socket.
5. Remove retainer.
6. Remove pinion assembly.
7. Use a 2 to 2.5 mm (0.079 to 0.098 in) diameter drill to completely remove staked portion of gear housing end.

8. Remove end cover assembly with a suitable tool.
9. Draw out rack assembly.
10. Remove rack seal ring.
 - Using a heat gun, heat rack seal to approximately 40°C (104°F).
 - Remove rack seal ring.

Be careful not to damage rack.

11. Remove center bushing and rack oil seal using tape wrapped socket and extension bar.

Do not scratch inner surfaces of pinion housing.

Inspection

Thoroughly clean all parts in cleaning solvent or automatic transmission fluid type DEXRON™III or equivalent. Blow dry with compressed air, if available.

BOOT

- Check condition of boot. If cracked excessively, replace it.
- Check boots for accumulation of power steering fluid.

GI

MA

EM

LC

EC

FE

CL

MT

AT

FA

RA

BR

ST

RS

BT

HA

EL

IDX

POWER STEERING GEAR AND LINKAGE

Inspection (Cont'd)

RACK

Thoroughly examine rack gear. If damaged, cracked or worn, replace it.

PINION ASSEMBLY

- Thoroughly examine pinion gear. If pinion gear is damaged, cracked or worn, replace it.
- Check that all bearings roll freely. Ensure that balls, rollers and races are not cracked, pitted or worn.

GEAR HOUSING CYLINDER

Check gear housing cylinder bore for scratches or other damage. Replace if necessary.

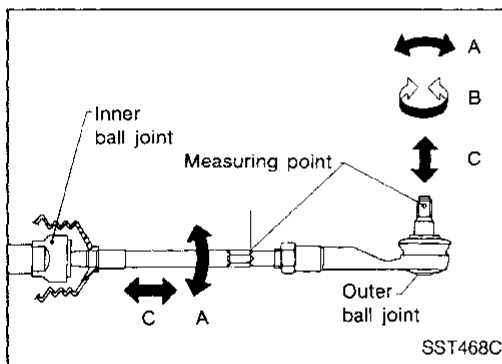

TIE-ROD OUTER AND INNER SOCKETS

- Check ball joints for swinging force.
Tie-rod outer and inner ball joints swinging force "A":
Refer to SDS (ST-27).
- Check ball joint for rotating torque.
Tie-rod outer ball joint rotating torque "B":
Refer to SDS (ST-27).
- Check ball joints for axial end play.
Tie-rod outer and inner ball joints axial end play "C":
Refer to SDS (ST-27).
- Check condition of dust cover. If cracked excessively, replace outer tie-rod.

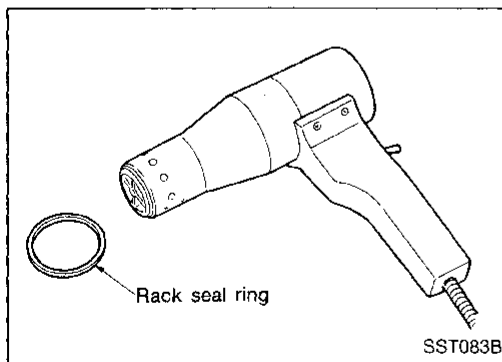

Assembly

1. Using a heat gun, heat new teflon rack seal ring to approximately 40°C (104°F). Then place it onto rack.

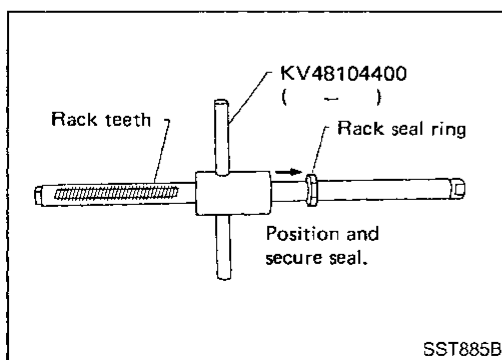

2. Using Tool, compress rack seal ring securely on rack.
Always insert Tool from the rack gear side.

POWER STEERING GEAR AND LINKAGE

Assembly (Cont'd)

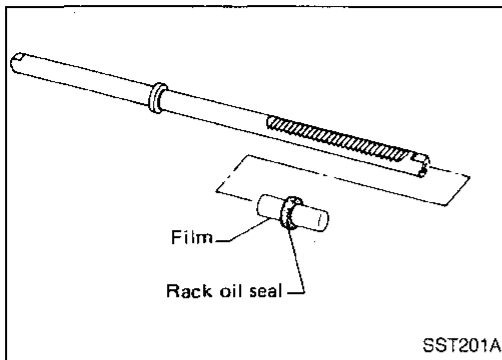

3. Insert new rack oil seal.

- Place plastic film into rack oil seal to prevent damage by rack teeth.
- Do not forget to remove plastic film after rack oil seal is positioned properly.
- Make sure lips of rack oil seal face each other.

GI

MA

EM

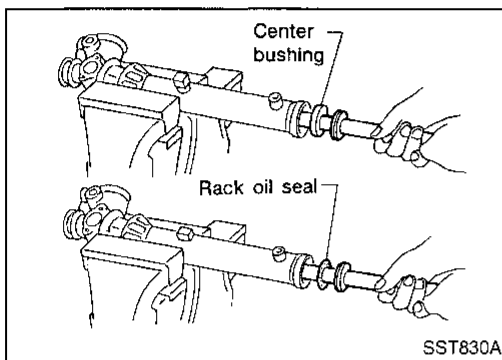

4. Install center bushing and rack oil seal with rack assembly.

LC

EC

FE

CL

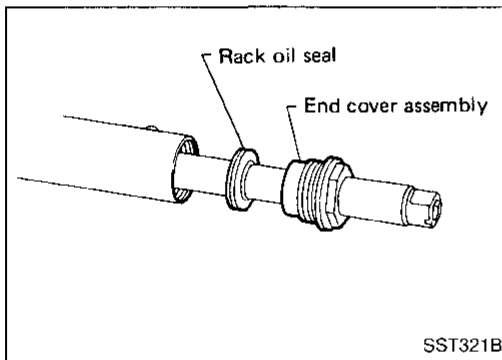

5. Insert rack oil seal and end cover assembly to rack. Then tighten end cover assembly.

MT

AT

FA

RA

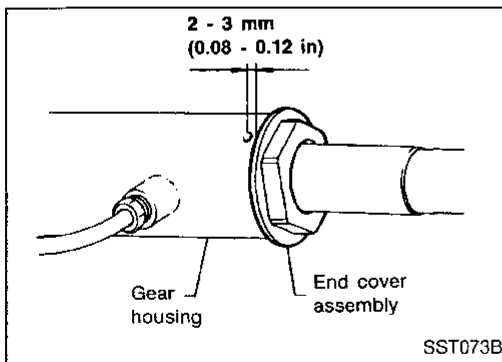

6. Fasten end cover assembly to gear housing by staking.

BR

ST

RS

BT

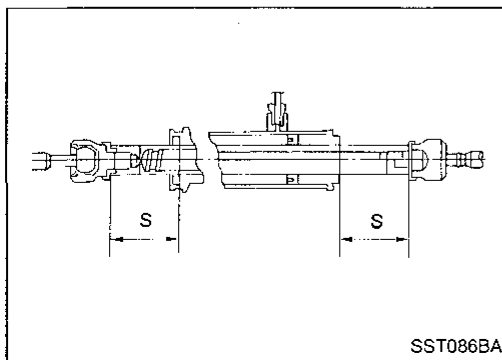

7. Set rack gear in neutral position.
Rack stroke "S":
 Refer to SDS (ST-27).

HA

EL

IDX

POWER STEERING GEAR AND LINKAGE

Assembly (Cont'd)

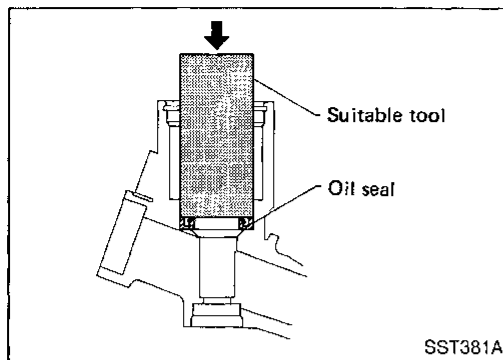

8. Coat seal lip of new pinion oil seal with multi-purpose grease. Install it into pinion housing of gear with a suitable tool.

Make sure lip of oil seal faces up when installed.

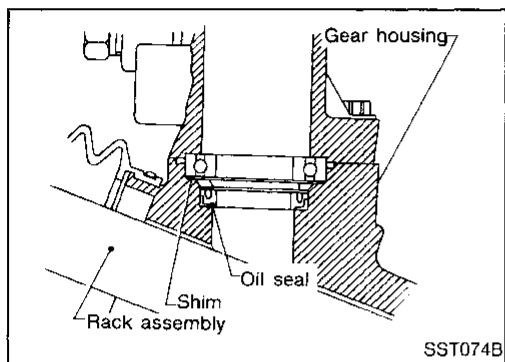

9. Install pinion bearing adjusting shim(s).
- Whenever pinion assembly, gear housing and rear housing are disassembled, replace shim(s) with new ones. Always use the same number of shim(s) when replacing.

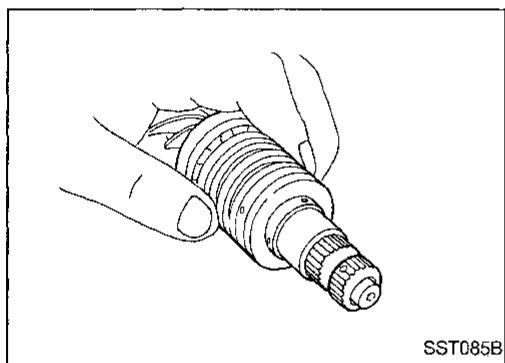

10. Install new pinion seal ring (made of Teflon) on pinion gear assembly.

- Using a heat gun, heat pinion seal ring to approximately 40°C (104°F) before installing it onto pinion gear assembly.
- Make sure pinion seal ring is properly settled in valve groove.

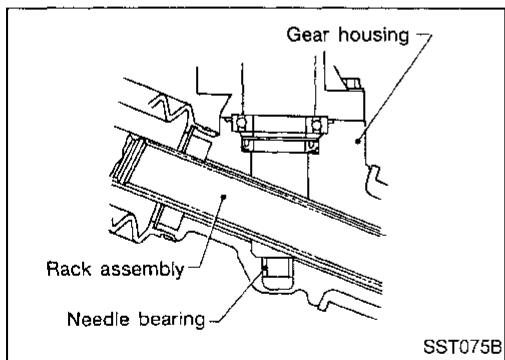

11. Apply a coat of multi-purpose grease to needle bearing roller and oil seal lip.

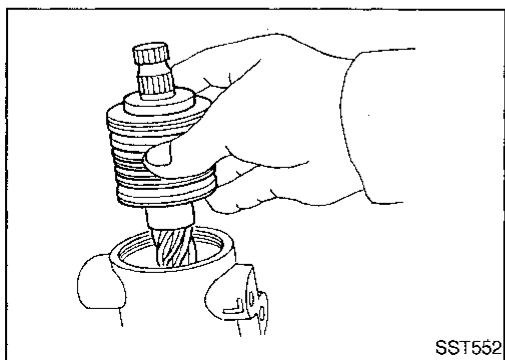

12. Install pinion assembly to rear housing.
Be careful not to damage pinion oil seal.

POWER STEERING GEAR AND LINKAGE

Assembly (Cont'd)

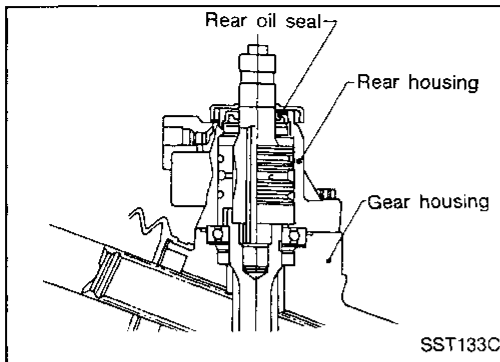

13. Apply a coat of multi-purpose grease to new rear oil seal lip before installing rear housing.

GI

MA

EM

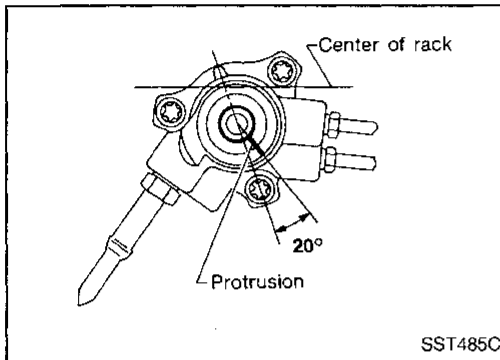

14. Ensure that the rack is centered. Install rear cover cap so that protrusion of rear housing cover is positioned as shown in figure.

LC

Be careful not to damage worm ring and oil seal.

EC

FE

CL

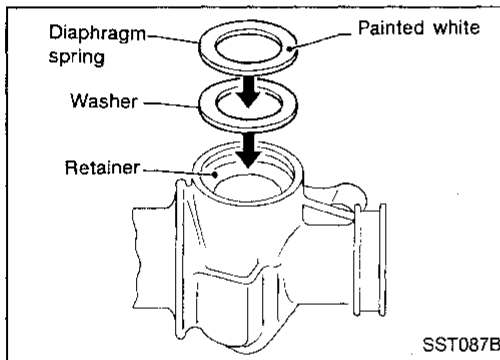

15. Install diaphragm spring into gear housing.

- Always install retainer, spring washer and diaphragm spring in that order.
- Make sure convex end (painted white) of diaphragm spring faces outward when installing.

MT

AT

16. Install retainer spring and adjusting screw temporarily.

FA

RA

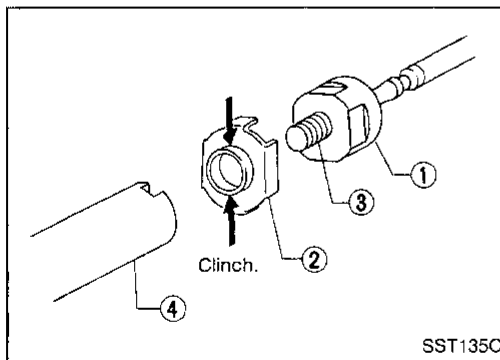

17. Install new lock plate.

- Attach lock plate ② to side rod inner socket ①.
- Apply locking sealant to inner socket threads ③.
- Screw inner socket into rack ④ and tighten to specified torque.
- Clinch two places of lock plate at rack's groove.

BR

ST

CAUTION:

To prevent scratching the boot, remove burrs from lock plate.

RS

BT

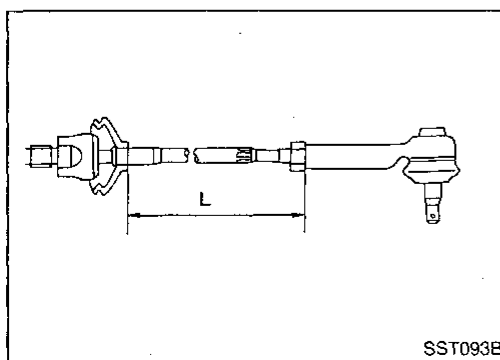

18. Tighten outer socket lock nut.

Tie-rod length "L":

Refer to SDS (ST-27).

HA

EL

IDX

POWER STEERING GEAR AND LINKAGE

Assembly (Cont'd)

19. Measure rack stroke.

Rack stroke "S":

Refer to SDS (ST-27).

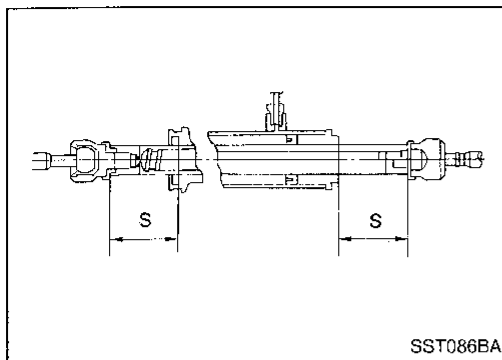

20. Before installing boot, coat the contact surfaces between boot and tie-rod with grease.

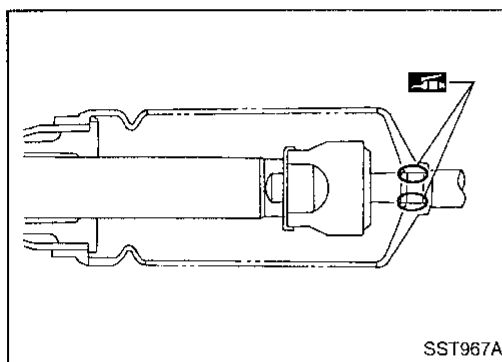

21. Install boot clamps.

- To install, wrap boot clamp around boot groove twice. To tighten clamp, place a screwdriver through both rings. Twist rings 4 to 4-1/2 turns while pulling with a force of approx. 98 N (10 kg, 22 lb).
- Twist boot clamp in the direction shown in figure at left.

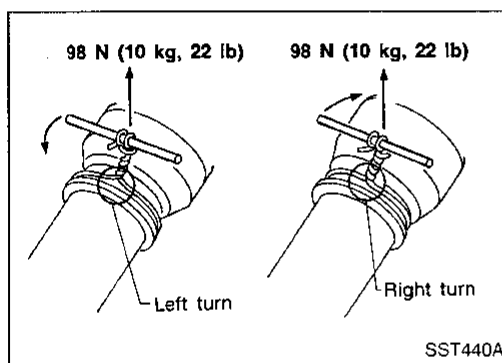

- Locate twisted end of boot clamp in the range shown. (This will prevent interference with other parts.)

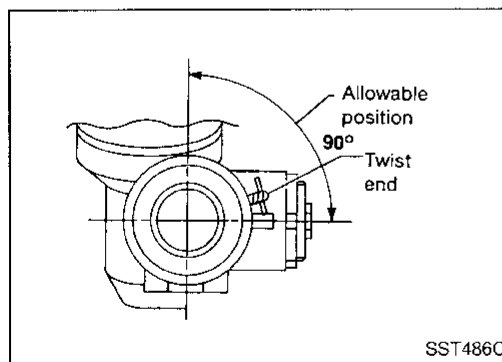

- After twisting boot clamp, bend twisted end diagonally so it does not contact boot.

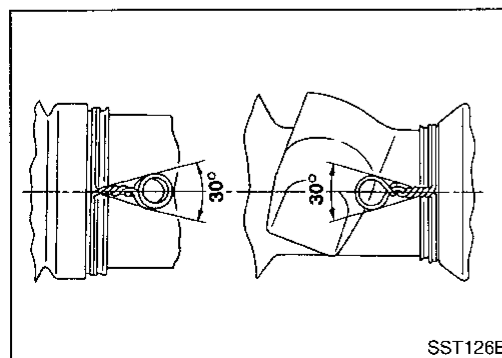

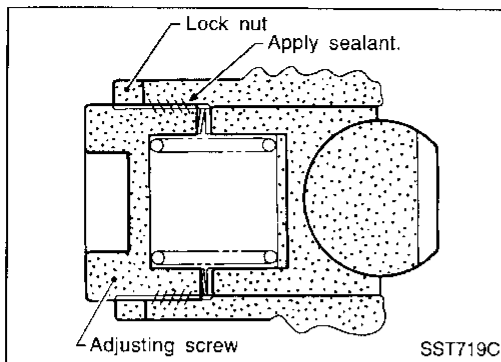

Adjustment

Adjust pinion rotating torque as follows:

1. Set rack to the neutral position without fluid in the gear.
2. Coat the adjusting screw with locking sealant and screw it in.
3. Lightly tighten lock nut.
4. Tighten adjusting screw to a torque of 4.9 to 5.9 N·m (50 to 60 kg·cm, 43 to 52 in·lb).
5. Loosen adjusting screw, then retighten it to 0.2 N·m (2 kg·cm, 1.7 in·lb).

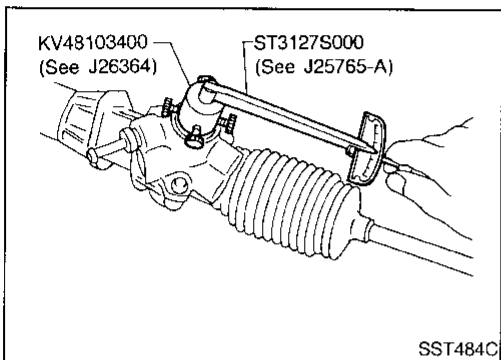

6. Move rack over its entire stroke several times.
7. Measure pinion rotating torque within the range of 180° from neutral position.
Stop the gear at the point of maximum torque.
8. Loosen adjusting screw, then retighten it to 4.9 N·m (50 kg·cm, 43 in·lb).
9. Loosen adjusting screw by 40° to 60°.

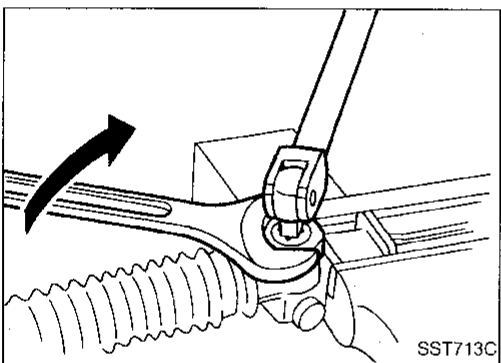

10. Prevent adjusting screw from turning, and tighten lock nut to specified torque.

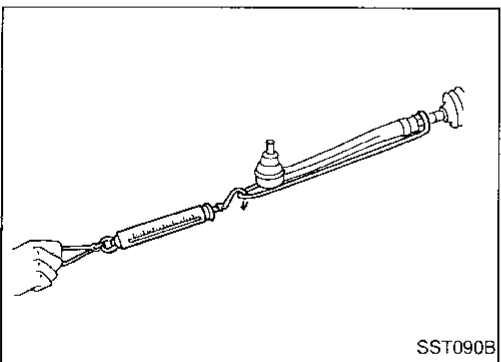

11. Check rack sliding force on vehicle as follows:
 - a. Install steering gear onto vehicle, but do not connect tie-rod to knuckle arm.
 - b. Connect all piping and fill with steering fluid.
 - c. Start engine and bleed air completely.
 - d. Disconnect steering column lower joint from the gear.
 - e. Keep engine at idle and make sure steering fluid has reached normal operating temperature.
 - f. Pull tie-rod slowly to move it from neutral position to ± 11.5 mm (± 0.453 in) at speed of 3.5 mm (0.138 in)/s. Check that rack sliding force is within specification.
Rack sliding force: 186 - 284 N (19 - 29 kg, 42 - 64 lb)
 - g. Check sliding force outside above range.
Rack sliding force: Not more than 294 N (30 kg, 66 lb)
 - If rack sliding force is not within specification, readjust by repeating adjustment procedure from the beginning.
 - If rack sliding force is still out of specification after readjustment, gear assembly needs to be replaced.

POWER STEERING OIL PUMP

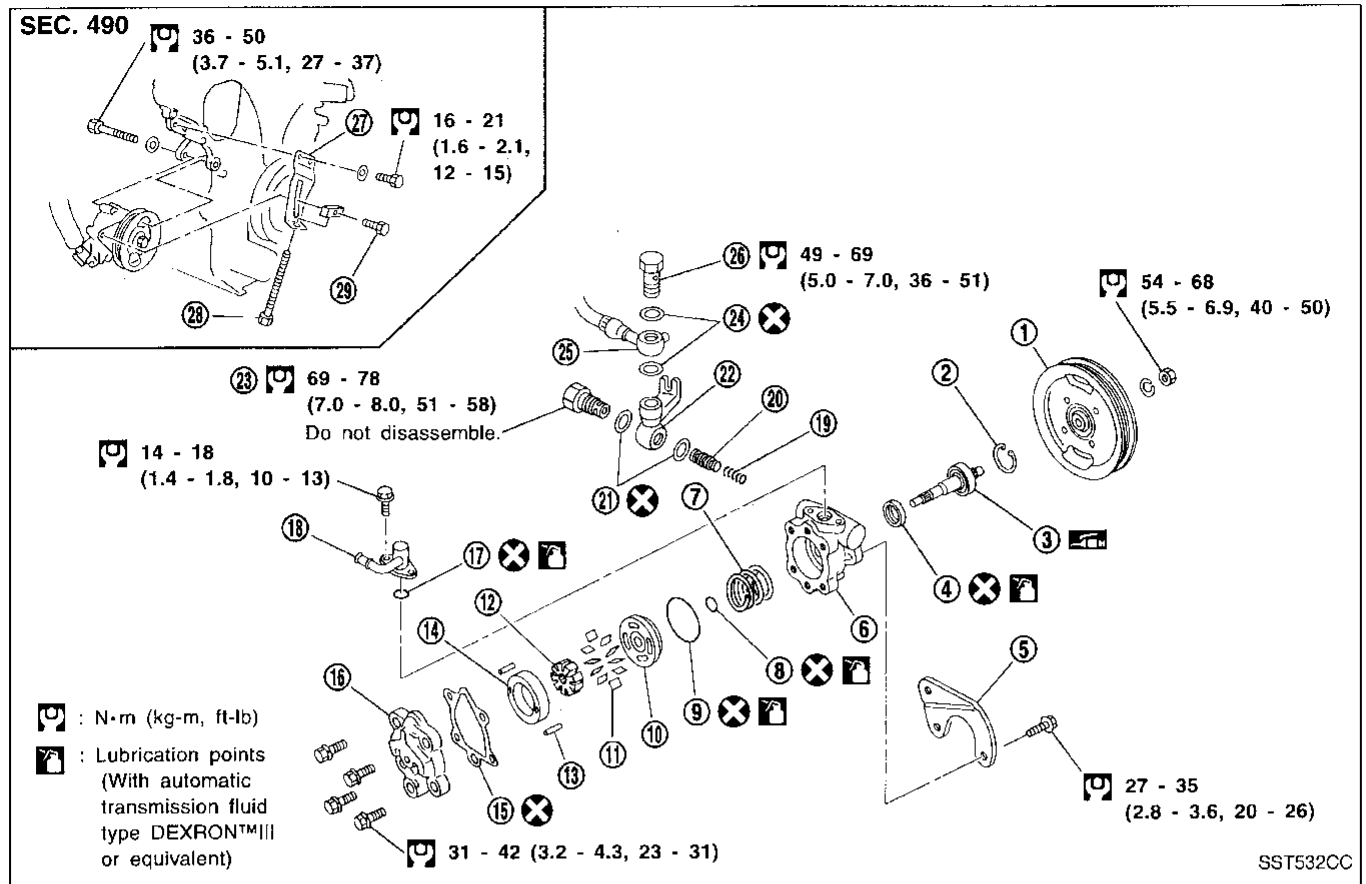

- | | | |
|------------------------|-----------------|---------------------|
| ① Pulley | ⑪ Vane | ⑳ Copper washer |
| ② Snap ring | ⑫ Rotor | ㉑ Joint |
| ③ Drive shaft assembly | ⑬ Pin | ㉒ Connector |
| ④ Oil seal | ⑭ Cam ring | ㉓ Copper washer |
| ⑤ Bracket | ⑮ Gasket | ㉔ Hose |
| ⑥ Front housing | ⑯ Rear housing | ㉕ Eye bolt |
| ⑦ Spring | ⑰ O-ring | ㉖ Adjusting bracket |
| ⑧ O-ring (Inner) | ⑱ Suction pipe | ㉗ Adjusting bolt |
| ⑨ O-ring (Outer) | ⑲ Spring | ㉘ Lock bolt |
| ⑩ Front side plate | ㉚ Control valve | |

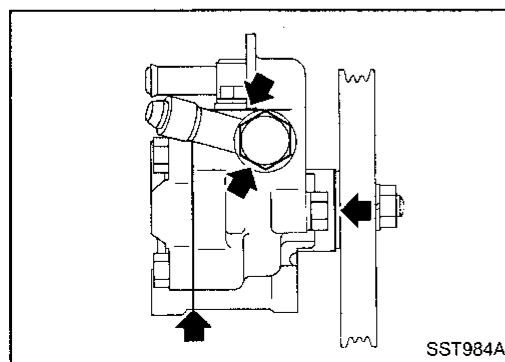

Pre-disassembly Inspection

Disassemble the power steering oil pump only if the following items are found.

- Oil leak from any point shown in the figure
- Deformed or damaged pulley
- Poor performance

Disassembly

CAUTION:

- Parts which can be disassembled are strictly limited. Never disassemble parts other than those specified.
- Disassemble in as clean a place as possible.
- Clean your hands before disassembly.
- Do not use rags; use nylon cloths or paper towels.
- Follow the procedures and cautions in the Service Manual.
- When disassembling and reassembling, do not let foreign matter enter or contact the parts.

- Remove snap ring, then draw drive shaft out.

Be careful not to drop drive shaft.

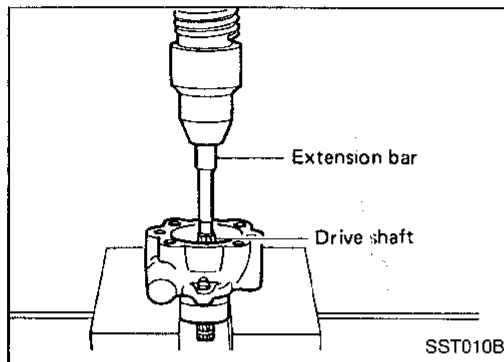

- Remove oil seal.

Be careful not to damage front housing.

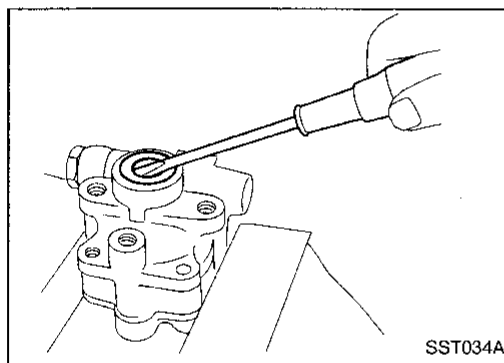

- Remove connector.

Be careful not to drop flow control valve.

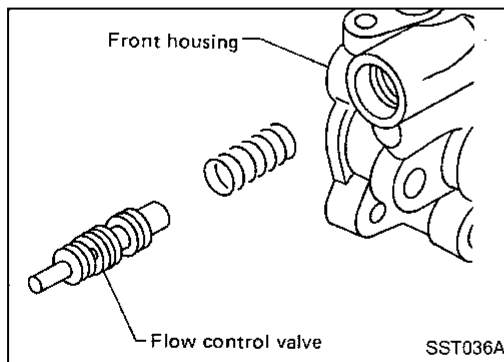

Inspection

Inspect each component part for wear, deformation, scratches and cracks. If damage is found, replace the part.

GI

MA

EM

LC

EC

FE

CL

MT

AT

FA

RA

BR

ST

RS

BT

HA

EL

IDX

POWER STEERING OIL PUMP

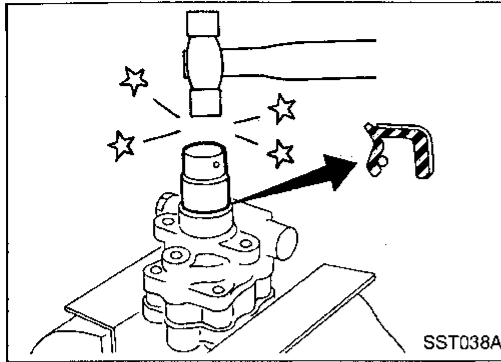

Assembly

Assemble oil pump, noting the following instructions.

- Make sure O-rings and oil seal are properly installed.
- Always install new O-rings and oil seal.
- Be careful of oil seal direction.
- Cam ring, rotor and vanes must be replaced as a set if necessary.
- Coat each part with ATF when assembling.

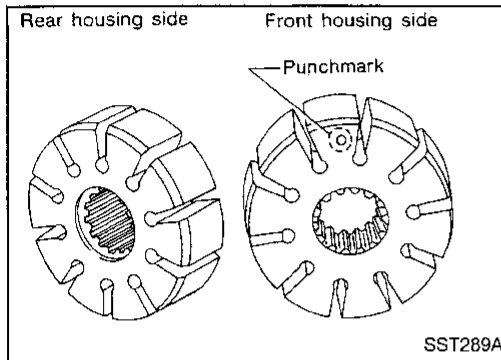

- Pay attention to the direction of rotor.

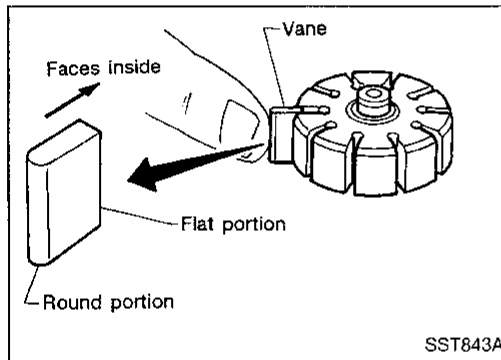

- When assembling vanes to rotor, rounded surfaces of vanes must face cam ring side.

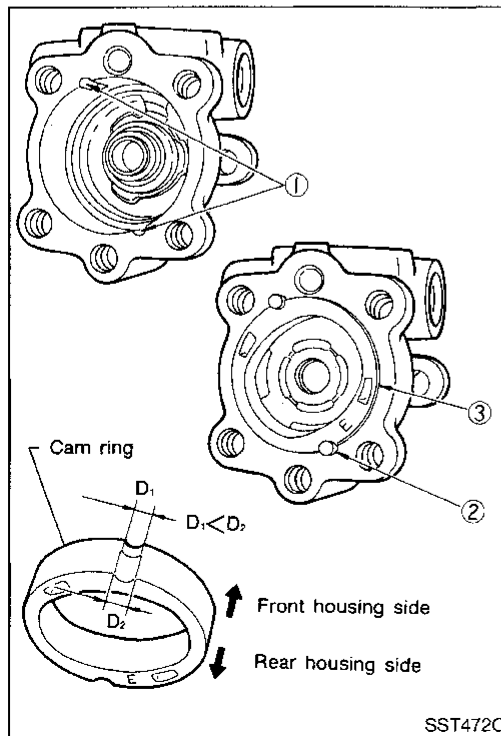

- Insert pin ② into pin groove ① of front housing and rotor. Then install cam ring ③ as shown at left.

SERVICE DATA AND SPECIFICATIONS (SDS)

General Specifications

Applied model	All
Steering model	Power steering
Steering gear type	PR26AC
Steering overall gear ratio	16.7
Turns of steering wheel (Lock to lock)	2.95
Steering column type	Collapsible, tilt

GI
MA
EM

Inspection and Adjustment

GENERAL

Steering wheel axial play mm (in)	0 (0)
Steering wheel play mm (in)	35 (1.38) or less
Movement of gear housing mm (in)	±2 (±0.08) or less

LC
EC

STEERING COLUMN

Applied model	All
Steering column length "L" mm (in)	525.9 - 528.1 (20.70 - 20.79)

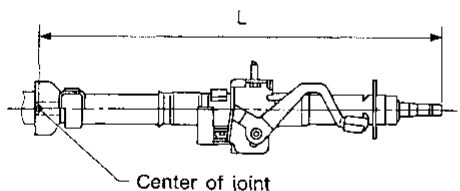

Center of joint

SST334C

STEERING GEAR AND LINKAGE

Steering gear type	PR26AC
Tie-rod outer ball joint "A"	
Swinging force at cotter pin hole N (kg, lb)	6.59 - 63.7 (0.672 - 6.497, 1.481 - 14.320)
Rotating torque "B" N-m (kg-cm, in-lb)	0.3 - 2.9 (3 - 30, 2.6 - 26.0)
Axial end play "C"	0.5 (0.020) or less
Tie-rod inner ball joint "A"	
Swinging force*	6.4 - 50.0 (0.65 - 5.10, 1.44 - 11.24)
Axial end play "C"	0 (0)
Tie-rod standard length "L"	202.7 (7.98)

*: Measuring point [ℓ: 172 mm (6.77 in)]

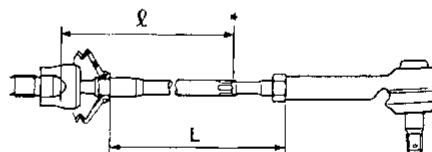

SST488C

Rack stroke "S"	70.5 (2.776)
-----------------	--------------

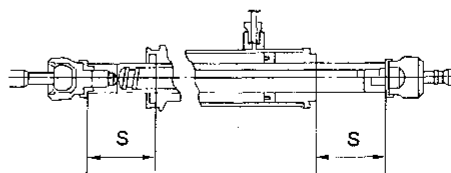

SST086BA

FE
CL
MT
AT
FA

RA
BR

ST

RS
BT

HA
EL

IDX

SERVICE DATA AND SPECIFICATIONS (SDS)

Inspection and Adjustment (Cont'd)

POWER STEERING

Rack sliding force Under normal operating oil pressure at rack speed of 3.5 mm (0.138 in)/s Range within ± 11.5 mm (± 0.453 in) from the neutral position	N (kg, lb) 186 - 284 (19 - 29, 42 - 64)
Except above range	Not more than 294 (30, 66)
Retainer adjustment Adjusting screw	
Initial tightening torque N-m (kg-cm, in-lb)	4.9 - 5.9 (50 - 60, 43 - 52)
Retightening torque after loosening	0.2 (2, 1.7)
Tightening torque after gear has settled	4.9 (50, 43)
Returning angle degree	40° - 60°
Steering wheel turning force (Measured at one full turn from the neutral position) N (kg, lb)	39 (4, 9) or less
Fluid capacity (Approximate) ℓ (US qt, Imp qt)	1.1 (1-1/8, 1)
Oil pump maximum pressure kPa (kg/cm ² , psi)	8,140 - 8,728 (83 - 89, 1,180 - 1,266)